

Highway Engineering I

Course

Lecture note

Table of Contents

CHAPTER 1	1
1 Overview of the highway planning and development process.....	1
1.1 Introduction.....	1
1.2 The Stages of Highway Development	1
CHAPTER 2	7
2 Highway Route Surveys and Location.....	7
2.1 Introduction.....	7
2.2 Highway Alignment and Route Location Survey	8
2.3 Guidelines for Alignment and Route Location	9
2.4 Reconnaissance survey	10
2.5 Preliminary Location Survey	12
2.6 Final Location Survey.....	14
CHAPTER 3	16
3 GEOMETRIC DESIGN OF HIGHWAYS.....	16
3.1 Appropriate Geometric Standards.....	16
3.2 Design Controls and Criteria.....	18
3.3 Horizontal Alignment	22
3.4 Vertical Alignment.....	32
3.5 Cross-Section	38
CHAPTER 4	42
4 EARTHWORK COMPUTATIONS.....	42
4.1 Introduction.....	42
4.2 Volume of Earthwork.....	47
4.3 Haul and Overhaul	47
4.4 Mass Diagram	48
CHAPTER FIVE	51
5 HIGHWAY DRAINAGE	51
5.1 Introduction.....	51
5.2 Surface drainage.....	51
5.3 Determination of Runoffs	52
5.4 Design of Open Channels	56
5.5 Subsurface Drainage	58

CHAPTER SIX.....	63
6 INTERSECTION AND INTERCHANGES.....	63
6.1 Types of Intersection.....	63
6.2 Design Consideration and Objectives	66
6.3 Conflict area at Intersection	66
6.4 Type of Intersection Control	67
6.4.1 Stop signs	67
6.4.2 Yield Signs.....	68
6.4.3 Intersection Channelization.....	68
6.4.4 Uncontrolled Intersections	70
6.5 Interchanges	72

CHAPTER 1

1 Overview of the highway planning and development process

1.1 Introduction

Highway design is only one element in the overall highway development process. Historically, detailed design occurs in the middle of the process, linking the preceding phases of planning and project development with the subsequent phases of right-of-ways acquisition, construction, and maintenance. While these are distinct activities, there is considerable overlap in terms of coordination among the various disciplines that work together, including designers, throughout the process.

It is during the first three stages, planning, project development, and design, that designers and communities, working together, can have the greatest impact on the final design features of the project. In fact, the flexibility available for highway design during the detailed design phase is limited a great deal by the decisions made at the earlier stages of planning and project development.

- Successful process includes designer and community involvement from the beginning.

1.2 The Stages of Highway Development

Although the names may vary, the five basic stages in the highway development process are: planning, project development (preliminary design), final design, right of way, and construction. After construction is completed, ongoing operation and maintenance activities continue throughout the life of the facility.

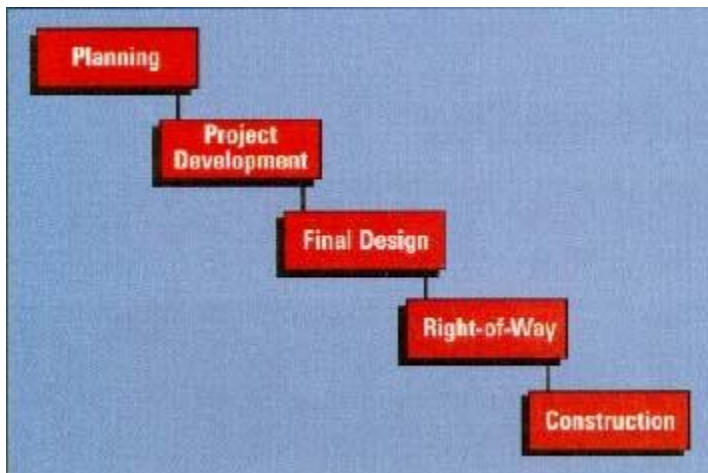

✓ **Planning**

The initial definition of the need for any highway or bridge improvement project takes place during the planning stage. This problem definition occurs at the State, regional, or local level, depending on the scale of the proposed improvement. This is the key time to get the public involved and provide input into the decision making process. The problems identified usually fall into one or more of the following four categories:

1. The existing physical structure needs major repair/replacement (structure repair).
2. Existing or projected future travel demands exceed available capacity, and access to transportation and mobility need to be increased (capacity).
3. The route is experiencing an inordinate number of safety and accident problems that can only be resolved through physical, geometric changes (safety).
4. Developmental pressures along the route make a reexamination of the number, location, and physical design of access points necessary (access).

Whichever problem (or set of problems) is identified, it is important that all parties agree that the problem exists, pinpoint what the problem is, and decide whether or not they want it fixed. For example, some communities may acknowledge that a roadway is operating over its capacity but do not want to improve the roadway for fear that such action will encourage more growth along the corridor. Road access may be a problem, but a community may decide it is better not to increase access,

- Increased public involvement in highway planning and development is essential to success.

• **Factors to Consider During Planning**

It is important to look ahead during the planning stage and consider the potential impact that a proposed facility or improvement may have while the project is still in the conceptual phase. During planning, key decisions are made that will affect and limit the design options in subsequent phases. Some questions to be asked at the planning stage include:

- How will the proposed transportation improvement affect the general physical character of the area surrounding the project?
- Does the area to be affected have unique historic or scenic characteristics?
- What are the safety, capacity, and cost concerns of the community?

Answers for such questions are found in planning level analysis, as well as in public involvement during planning.

Figure 1.1
Factors to consider
in planning.



✓ Project Development

After a project has been planned and programmed for implementation, it moves into the project development phase. At this stage, the environmental analysis intensifies. The level of environmental review varies widely, depending on the scale and impact of the project. It can range from a multiyear effort to prepare an Environmental Impact Statement (a comprehensive document that analyzes the potential impact of proposed alternatives) to a modest environmental review completed in a matter of weeks. Regardless of the level of detail or duration, the product of the project development process generally includes a description of the location and major design features of the recommended project that is to be further designed and constructed, while continually trying to avoid, minimize, and mitigate environmental impact.

The basic steps in this stage include the following:

- Refinement of purpose and need
- Development of a range of alternatives (including the "no build" and traffic management system [TMS] options)
- Evaluation of alternatives and their impact on the natural and built environments
- Development of appropriate mitigation

In general, decisions made at the project development level help to define the major features of the resulting project through the remainder of the design and construction process. For example, if the project development process determines that an improvement needs to take the form of a four lane divided arterial highway, it may be difficult in the design phase to justify providing only a two lane highway. Similarly, if the project development phase determines that an existing truss bridge cannot be rehabilitated at a reasonable cost to provide the necessary capacity, then it may be difficult to justify keeping the existing bridge without investing in the cost of a totally new structure.

✓ **Final Design**

After a preferred alternative has been selected and the project description agreed upon as stated in the environmental document, a project can move into the final design stage. The product of this stage is a complete set of plans, specifications, and estimates (PS&Es) of required quantities of materials ready for the solicitation of construction bids and subsequent construction. Depending on the scale and complexity of the project, the final design process may take from a few months to several years.

The need to employ imagination, ingenuity, and flexibility comes into play at this stage, within the general parameters established during planning and project development. Designers need to be aware of design related commitments made during project planning and project development, as well as proposed mitigation. They also need to be cognizant of the ability to make minor changes to the original concept developed during the planning phase that can result in a "better" final product.

The interests and involvement of affected stakeholders are critical to making design decisions during this phase, as well. Many of the same techniques employed during earlier phases of the project development process to facilitate public participation can also be used during the design phase.

The following paragraphs discuss some important considerations of design, including:

- Developing a concept
- Considering scale and
- Detailing the design.

➤ **Developing a Concept**

A design concept gives the project a focus and helps to move it toward a specific direction. There are many elements in a highway, and each involves a number of separate but interrelated design decisions. Integrating all these elements to achieve a common goal or concept helps the designer in making design decisions.

Some of the many elements of highway design are

- a. Number and width of travel lanes, median type and width, and shoulders
- b. Traffic barriers
- c. Overpasses/bridges
- d. Horizontal and vertical alignment and affiliated landscape.

➤ **Considering Scale**

People driving in a car see the world at a much different scale than people walking on the street. This large discrepancy in the design scale for a car versus the design scale for people has changed the overall planning of our communities. For example, it has become common in many suburban commercial areas that a shopper must get in the car and drive from one store to the next. Except in the case of strip malls, stores are often separated by large parking lots and usually have no safe walkways for pedestrians. This makes it difficult to get around any other way but by car. This type of design scale is in sharp contrast to preautomobile commercial areas that commonly took the form of "main streets," where walking from one store to the next was the norm.

Trying to accommodate users of the road who have two different design scales is a difficult task for designers; however, designers must always consider the safety of pedestrian and non vehicular traffic, along with the safety of motorists. Both are users of the road. In many road designs, pedestrian needs were considered only after the needs of motorized vehicles. Not only does this make for unsafe conditions for pedestrians, it can also drastically change how a roadway corridor is used. Widening a roadway that once allowed pedestrian access to the two sides of the street can turn the roadway into a barrier and change the way pedestrians use the road and its edges.

The design element with the greatest effect on the scale of the roadway is its width, or cross section. The cross section can include a clear zone, shoulder, parking lanes, travel lanes, and/or median. The wider the overall roadway, the larger its scale; however, there are some design techniques that can help to reduce the perceived width and, thus, the perceived scale of the roadway. Limiting the width of pavement or breaking up the pavement is one option. In some instances, four lane roadways may look less imposing by designing a grass or planted median in the center.

➤ **Detailing the Design**

Particularly during the final design phase, it is the details associated with the project that are important. Employing a multidisciplinary design team ensures that important design details are considered and those they are compatible with community values. Often it is the details of the project that are most recognizable to the public.

A multidisciplinary design team can produce an aesthetic and functional product when the members work together and are flexible in applying guidelines.

✓ **Right-of-way, Construction, And Maintenance**

Once the final designs have been prepared and needed right-of-way is purchased, construction bid packages are made available, a contractor is selected, and construction is initiated. During the right-of-way acquisition and construction stages, minor adjustments in the design may be necessary; therefore, there should be continuous involvement of the design team throughout

these stages. Construction may be simple or complex and may require a few months to several years. Once construction has been completed, the facility is ready to begin its normal sequence of operations and maintenance.

Even after the completion of construction, the character of a road can be changed by inappropriate maintenance actions. For example, the replacement of sections of guardrail damaged or destroyed in crashes commonly utilizes whatever spare guardrail sections may be available to the local highway maintenance personnel at the time. The maintenance personnel may not be aware of the use of a special guardrail design to define the "character" of the highway. When special design treatments are used, ongoing operation and maintenance procedures acknowledging these unusual needs should be developed.

❖ Stages of Highway Development

- Summaries of the five basic stages in highway planning and development.

Stages	Description of Activity
Planning	Identification of transportation needs and program project to be built Within financial constraints.
Project Development	The transportation project is more clearly defined. Alternative locations and design features are developed and an alternative is selected.
Design	The design team develops detailed design and specification.
Right-of-way	Land needed for the project is acquired.
construction	Selection of contractor, who then builds the project.

CHAPTER 2

2 Highway Route Surveys and Location

2.1 Introduction

To determine the geometric features of road design, the following surveys must be conducted after the necessity of the road is decided.

Type of surveys and investigations

A variety of survey and investigations have to be carried out by Road engineers and multidiscipline persons.

A. Transport Planning Surveys

- o Traffic Surveys
- o Highway inventories
- o Pavement Deterioration Study
- o Accident study

B. Alignment and Route location surveys

- o Desk study
- o Reconnaissance survey
- o Preliminary Survey
- o Final location survey

C. Drainage Studies

- o Surface run- off : hydrologic and hydraulic
- o Subsurface drainage: Ground water & Seepage
- o Cross –drainage: location and waterway area required for the cross-drainage structures.

D. Soil Survey

- o Desk study
- o Site Reconnaissance
- o Determining the complete soil profile through appropriate soil exploration techniques; obtaining both disturbed and undisturbed samples and testing of samples

E. Pavement Design investigation

- o Soil property and strength ,Material Survey

2.2 Highway Alignment and Route Location Survey

Once the necessity of the highway is assessed, the next process is deciding the alignment and route location. The position or the layout of the central line of the highway on the ground is called the alignment. Horizontal alignment includes straight and curved paths. Vertical alignment includes curves and gradients. Alignment decision is important because a bad alignment will enhance the construction, maintenance and vehicle operating costs. Once an alignment is fixed and constructed, it is not easy to change it due to increase in cost of adjoining land and construction of costly structures by the roadside.

In general, the aim of alignment selection process is to find a location for the new road that will result in the lowest total construction, land, traffic and environmental costs.

Before an attempt can be made at selecting a physical location for a highway improvement, data must be available regarding traffic desires and needs the planning intentions within the area to be traversed, and estimates or the future physical characteristics of the highway itself: Location surveys involving geologic and photogrammetric skills provide the basic information for structural design, as well as the economic analysis that have a considerable influence on the final location of the highway.

❖ Steps in route location:

- Know the termini points of the scheme.
- From the study of a map of the area, identify and locate:
 - National parks
 - Any ancient relics, castles and the likes
 - Existence of monasteries
 - Mining sites
 - Existing transport facilities
 - Other public facilities (electricity, water)
 - Location of construction materials
- Conduct preliminary and reconnaissance surveys and collect information on pertinent details of topography, climate, soil, vegetation, and any other factors.
- Based on the information collected in the previous two steps select a corridor.
- Identify a number of possible centerlines within the corridor.
- Make a preliminary design for the possible alternative alignments and plot on a base map.
- Examine each of the alternative alignment with respect to grades, volume of earthwork, drainage, crossing structures, etc to select the best alternative route.
- Make final design and location of the selected best alternative route

2.3 Guidelines for Alignment and Route Location

There are certain guidelines that must be borne in mind in selecting the alignment and locating the route. They are:

- The route of the highway should be so selected that it can handle the traffic most efficiently and serve the inhabited localities.
- The alignment should be economical and it can be considered so only when the initial cost, maintenance cost, and operating cost are minimum.
- The alignment should be easy to construct and maintain. It should be easy for the operation of vehicles. So to the maximum extent easy gradients and curves should be provided.
- The alignment between two terminal stations should be short and as far as possible be straight, but due to some practical considerations deviations may be needed.
- The gradients should not be steeper and curvature not sharper than the limiting values specified for different types of terrain or standards. Excess of either or both may result in economy of initial cost, but will involve extremely high operation costs, time costs and accident costs.
- The location should minimize the use of agricultural land. If a road already exists, it may be advisable to make use of the land already available to the maximum extent.
- The location should involve the least impact on the environment.
- Obstructions such as cemeteries, places of worship, archaeological and historical monuments should be steered through.
- Proximity to schools, playgrounds, very costly structures, lakes/ponds and hospitals should be avoided.
- Interference with utility services like electric overhead transmission lines, water supply mains, sewers, pipelines, etc should be avoided as far as possible.
- Frequent crossing of railway lines should be avoided.
- Locate the highway close to sources of embankment materials and pavement materials.
- Avoid marshy and low-lying land areas having poor drainage.
- Avoid areas liable to flooding.
- Steep terrain should be avoided as much as possible.
- Deep cutting and costly tunnels should be avoided as far as possible.
- Avoid areas subjected to subsidence due to mining operations.
- When the alignment has to cross major rivers, the crossing point should be fixed carefully.

Summary:

- ❖ Topography, slope stability, flood hazard and Erosion are likely to be the most significant in the choice of alignment and design of cross section.
- ❖ Geology, Geomorphology and hydrology are key factors in the design, construction and maintenance of road in Ethiopia. Road geometry, earth works, retaining structures and drainage measures must be designed in such a manner as

to cause the least impact on the stability of the surrounding slopes and natural drainage systems.

- ❖ To aid in the decision making process, a classical conceptual approach has tended to be developed with regard to gathering information about the areas being evaluated. Generally, these can be divided into:

- Reconnaissance survey
- Preliminary location survey
- Final location survey

2.4 Reconnaissance survey

The purpose of the reconnaissance survey is to evaluate the feasibility of one or more corridor routes for a highway between specific points that may be many kilometers away. Mostly a desk study, good reconnaissance survey can be the greatest single money-saving phase in the construction of a new road. Hence the engineer should make ample provision in both time and finance for this stage of highway location study.

The first step in the reconnaissance survey is the location and acquisition of all maps and data relating to the area, as well as the most suitable air photographs usually called desk study. And the second step of reconnaissance survey is visiting the site collecting additional data usually called as field study.

Desk study

The first step in route survey and investigation is to study all available information in the office, comprises a review of published and unpublished information concerning the Physical, economical and environmental characteristics of the study area.

Some of the data that may be required:

- Published literatures: Road construction and maintenance case histories and geological, economical and environmental reviews.
- Topographic Map
- Geological maps, Agricultural or land development map, soil map and other natural resource maps.
- Aerial Photography if possible satellite imagery (eg. Landsat/MSS and Radar images).

Available maps

<u>REFERENCE:</u>	<u>SOURCE</u>
- Index Map of Coverage Scales	Ethiopian Mapping Authority
- Atlas of Ethiopia	Ethiopian Mapping Authority
- Topographic Maps scale 1:250,000	Ethiopian Mapping Authority
- Topographic Maps scale 1:50,000	Ethiopian Mapping Authority
- Aerial photographs, approximate scale 1:50,000	Ethiopian Mapping Authority
- Geological Map of Ethiopia, scale 1:2,000,000	Geological Survey of Ethiopia
- Hydrological Map of Ethiopia, scale 1:2,000,000	Ministry of Agriculture
- Land Use and Land Cover Map, scale 1:1,000,000	Ministry of Agriculture
- Hydro geological Map, Scale 1:1,000, 000	Ethiopian Institute of Geological
<ul style="list-style-type: none"> • All possible routes shall be located and examined on maps, satellite and air photos. •  Field study 	

It involves inspection of each band (identified during the desk study) to determine the most corridor feasible route based on some basic criteria. A survey party inspects a fairly broad stretch of land along the proposed routes identified on the map during the 1st phase and collects all relevant details not available on the map.

- A team consisting of the following personal or Engineers should make a site inspection visit (ERA)
 - ✓ Highway Engineer
 - ✓ Soil & material (pavement) Engineer
 - ✓ Hydrologist
 - ✓ Chief Surveyor
 - ✓ Bridge/Structural Engineer
 - ✓ Environmentalist / Sociologist ,and
 - ✓ Local Administrative Personnel

- The following information or data should be determined or collected during the Reconnaissance survey
 1. Terrain classification
 2. Bridging requirements (number ,length)
 3. Existing means of communication (mule path, 4WD...)
 4. Right-of way available ,bringing out constraints on account of built-up areas, monuments and other structures
 5. Slope stability and the location of pre-existing land slides
 6. Geology of the area (Geological structures, rock strength...)
 7. Percentage of rock in excavation
 8. Construction Material sources, presence and distribution.
 9. Water source
 10. Location of existing or proposed utilities along the alignment
 11. Soil type and depth
 12. Land use and value of land (Agricultural, built-up, forest)
 13. Necessity of by passes for town and villages
 14. Likely foundation conditions for major structures.
 15. Slope drainage and ground water condition
 16. Soil erosion and soil erodibility.
 17. Drainage Stability and location of shifting channels and bank erosion.
 18. Flood levels and river training/ protection requirement
 19. Ecology or environmental factors (land use impact)
 20. The possibility of using any existing alignment.
 21. Verify the accuracy of all collected data during the desk study.

Upon completion of the reconnaissance survey, the engineer should be at least in a position to design the more detailed geotechnical investigations which are likely to follow, and should also have sufficient information available which, when taken in combination with the **social, ecology, traffic, economic, and political inputs**, will enable the selection of one or more apparently feasible corridor routes. If the reconnaissance survey has been very thorough, and the necessary data are readily available, it may be possible immediately to carry out the necessary economic and environmental comparisons to aid in the determination of the best corridor route.

The results of these studies are presented in a reconnaissance report. In its barest essentials, this report should state the service and geometric criteria to be satisfied by the project, describe the preferred route(s), and present tentative estimates of the cost.

2.5 Preliminary Location Survey

The preliminary survey is a large-scale study of one or more feasible corridor routes. It results in a paper location and alignment that defines the line for the subsequent final location survey. This paper location and alignment should show enough ties to existing topography to permit a location party to peg the centerline. In many cases field details for final design may also be obtained economically during the preliminary survey phase. It consists of running an accurate

traverse line along the routes already recommended as a result of reconnaissance survey in order to obtain sufficient data for final location.

- Establishing primary Traverse following the line recommended in the reconnaissance survey
- Record all topographical features
- Levelling work: to determine the Centre Line, Profile & Typical Cross-sections (just sufficient to approximate earthwork)
- Hydrological Data: to estimate type, number, & size of cross-drainage structures, and the grade line is decided based on the hydrological and drainage data
- Soil Survey: the suitability of proposed alignment is to be finally decided based on the soil survey data. The soil survey at this stage helps to workout details of earthwork, slopes, suitability of materials, sub-soil and surface drainage requirements, pavement type and approximate thickness requirements

The preliminary survey is made for the purpose of collecting the additional physical information that may affect the location of the highway within a given corridor area, the shape of the ground, any potential ground subsidence problems, the limits of the catchment areas, the positions and invert levels of streams and ditches, and the positions of trees, banks and hedges, bridges, culverts, existing roads, power lines and pipe lines, houses and monuments are determined and noted. These are then translated into maps, profiles and (frequently) cross sections that can assist the engineer in the determination of preliminary grades and alignments and the preparation of cost estimates for alternative centerlines.

Two approaches are available for preliminary survey mapping: aerial surveys and ground surveys, either separately or in various combinations.

The ground survey method is best used in the situation where then corridor is closely defined, narrow right-of-way are contemplated, and the problems of man-made culture are clear. Ground surveys, beginning with a traverse baseline, will probably furnish necessary data quite economically. Additional operations that can be quite easily included are the profile levels and cross-sections, and the ties to land lines and cultural objects.

The aerial survey is likely to be more suitable and economical in the following instances:

- Where the reconnaissance was unable to approximate closely the final alignment?
- Where a wide right-of-way is necessitated?
- Where it is desired to prevent the premature or erroneous disclosure of the details of probable location (preventing any land speculation or the premature awakening of local public concerns).

In general, the objectives of preliminary surveys are

- Survey and collect necessary data (topography, drainage, soil, etc.) on alternate corridor routes.
 - Establishing primary Traverse following the line recommended in the reconnaissance survey.
 - Record all topographical features.
 - Levelling work: to determine the Centre Line, Profile & Typical Cross-sections (just sufficient to approximate earthwork)
 - Hydrological Data: to estimate type, number, & size of cross-drainage structures, and the grade line is decided based on the hydrological and drainage data.
 - Soil Survey: the suitability of proposed alignment is to be finally decided based on the soil survey data. The soil survey at this stage helps to work out details of earthwork, slopes, suitability of materials, sub-soil and surface drainage requirements, pavement type and approximate thickness requirements
- To estimate quantity of earthwork, material, ... of different corridor routes
- Compare alternate corridor routes.

Finalize the best corridor routes from all consideration

2.6 Final Location Survey

This survey, much of which is very often carried out as part of the preliminary survey, serves the dual purpose to fix the centre line of the selected alignment and collect additional data for the design and preparation of working drawings. If extensive data is collected earlier the survey work here might be limited.

Steps in Final Location Survey

- Pegging the centre line: usually done at stations established at 30m intervals with reference to preliminary traverse/ base line (if used earlier) or a control survey (if aerial survey was used).
- Centre-line Levelling: at the stations and at intermediate points between stations where there is a significant change in the slope to obtain the representative profile of the ground
- Cross-section Levelling: at each station and at points with significant change in ground slope
- Intersecting Roads: the directions of the centre line of all intersecting roads, profiles, and cross-sections for some distance on both sides.
- Ditches and Streams: horizontal alignment, profile, and cross section levelling of the banks of the stream.

The data, after the necessary investigation and final location survey, is sent to the design office to be used for

- geometric design, pavement design, and design of drainage and other structures, preparation of drawings, reports, and specifications
- ✓ A complete sets of drawings for a road design include:
 - Site plan of proposed alignment
 - Detailed Plan & Profile
 - Cross-sections for Earth work
 - Typical Roadway sections at selected locations (e.g. junctions)
 - A mass-haul diagram
 - Construction details of structures like bridges, culverts,

CHAPTER 3

3 GEOMETRIC DESIGN OF HIGHWAYS

Geometric design is the process whereby the layout of the road in the terrain is designed to meet the needs of the road users.

3.1 Appropriate Geometric Standards

The needs of road users in developing countries are often very different from those in the industrialized countries. In developing countries, pedestrians, animal-drawn carts, etc., are often important components of the traffic mix, even on major roads. Lorries and buses often represent the largest proportion of the motorized traffic, while traffic composition in the industrialized countries is dominated by the passenger car. As a result, there may be less need for high-speed roads in developing countries and it will often be more appropriate to provide wide and strong shoulders. Traffic volumes on most rural roads in developing countries are also relatively low. Thus, providing a road with high geometric standards may not be economic, since transport cost savings may not offset construction costs. The requirements for wide carriageways, flat gradients and full overtaking sight distance may therefore be inappropriate. Also, in countries with weak economies, design levels of comfort used in industrialized countries may well be a luxury that cannot be afforded.

When developing appropriate geometric design standards for a particular road in a developing country, the first step should normally be to identify the objective of the road project. It is convenient to define the objective in terms of three distinct stages of development as follows:

Stage 1 – Provision of access

Stage 2 - Provision of additional capacity

Stage 3 – Increase of operational efficiency

Developing countries, by their very nature, will usually not be at stage 3 of this sequence; indeed most will be at the first stage. However, design standards currently in use are generally developed for countries at stage 3 and they have been developed for roads carrying relatively large volumes of traffic. For convenience, these same standards have traditionally been applied to low-volume roads that lead to uneconomic and technically inappropriate designs.

A study to develop appropriate geometric design standards for use in developing countries has been undertaken by the Overseas Unit of Transport Research Laboratory (TRL formerly TRRL). The study revealed that most standards currently in use are considerably higher than can be justified from an economic or safety point of view. Geometric design recommendations have been published in Overseas Road Note 6.

In the above-mentioned Overseas Road Note 6 rural access roads are classified into three groups.

Access roads are the lowest level in the network hierarchy. Vehicular flows will be very light and will be aggregated in the collector road network. Geometric standards may be low and need only be sufficient to provide appropriate access to the rural agricultural, commercial, and population centers served. Substantial proportions of the total movements are likely to be by non-motorized traffic.

Collector roads have the function of linking traffic to and from rural areas, either direct to adjacent urban centers, or to the arterial road network. Traffic flows and trip lengths will be of an intermediate level and the need for high geometric standards is therefore less important.

Arterial roads are the main routes connecting national and international centers. Trip lengths are likely to be relatively long and levels of traffic flow and speed relatively high. Geometric standards need to be adequate to enable efficient traffic operation under these conditions, in which vehicle-to-vehicle interactions may be high.

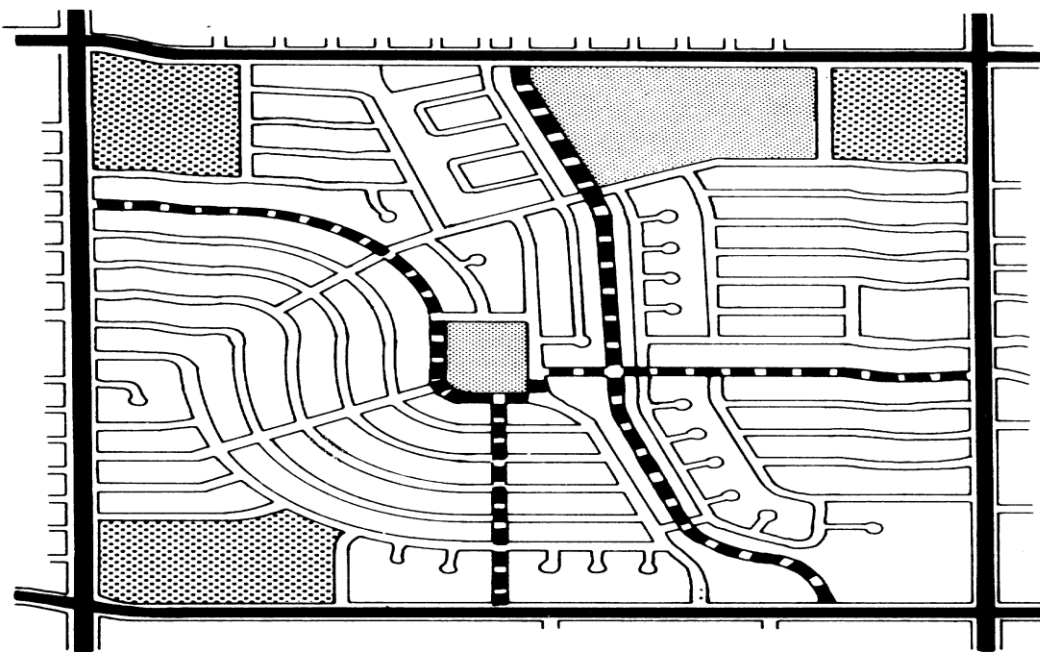

LEGEND

	Arterial Street		Collector Street
	Commercial Area		Public Area
	Local Street		

3.2 Design Controls and Criteria

The elements of design are influenced by a wide variety of design controls, engineering criteria, and project specific objectives. Such factors include the following:

- Functional classification of the roadway
- Projected traffic volume and composition
- Required design speed
- Topography of the surrounding land
- Capital costs for construction
- Human sensory capacities of roadway users
- Vehicle size and performance characteristics
- Traffic safety considerations
- Environmental considerations
- Right-of-way impacts and costs

These considerations are not, of course, completely independent of one another. The functional class of a proposed facility is largely determined by the volume and composition of the traffic to be served. It is also related to the type of service that a highway will accommodate and the speed that a vehicle will travel while being driven along a highway.

Of all the factors that are considered in the design of a highway, the principal design criteria are traffic volume, design speed, sight distances, vehicle size, and vehicle mix.

Design Speed and Design Class

The assumed **design speed** for a highway may be considered as “ the maximum safe speed that can be maintained over a specified section of a highway when conditions are so favorable that the design features govern”. The choice of design speed will depend primarily on the surrounding terrain and the functional class of the highway. Other factors determining the selection of design speed include traffic volume, costs of right-of-way and construction, and aesthetic consideration.

It is therefore recommended that the basic parameters of road function, terrain type and traffic flow are defined initially. On the basis of these parameters, a design class is selected, while design speed is used only as an index which links design class to the design parameters of sight distance and curvature to ensure that a driver is presented with a reasonably consistent speed environment.

Table 3.1 shows the design classes and design speeds recommended in Overseas Road Note 6 in relation to road function, volume of traffic and terrain. The table also contains recommended standards for carriageway and shoulder width and maximum gradient.

The terrain classification as 'level', 'rolling' or 'mountainous' may be defined as average ground slope measured as the number of five-meter contour lines crossed per kilometer on a straight line linking the two ends of the road section as follows:

- Level terrain: 0 – 10 ground contours per kilometer;
- Rolling terrain: 11 – 25 ground contours per kilometer;
- Mountainous terrain: > 25 ground contours per kilometer.

Table 3.1 Road design standards (TRRL Overseas Road Note 6)

Road Function	Design Class	Traffic Flow* (ADT)	Surface Type	Width (m)		Maximum Gradient (%)	Terrain/Design Speed (km/h)		
				Carriage-way	Shoulder		Mountainous	Rolling	Level
Arterial	A	5000–15000	Paved	6.5	2.5	8	85	100	120
	B	1000–5000	Paved	6.5	1.0	8	70	85	100
Collector	C	400–1000	Paved	5.5	1.0	10	60	70	85
	D	100–400	Paved/Unpaved	5.0	1.0 [†]	10	50	60	70
Access	E	20–100	Paved/Unpaved	3.0	1.5 [†]	15	40	50	60
	F	<20	Paved/Unpaved	2.5/3.0	Passing Places	15/20	N/A	N/A	N/A

Sight Distance

The driver's ability to see ahead contributes to safe and efficient operation of the road. Ideally, geometric design should ensure that at all times any object on the pavement surface is visible to the driver within normal eye-sight distance. However, this is not usually feasible because of topographical and other constraints, so it is necessary to design roads on the basis of lower, but safe, sight distances.

There are three different sight distances that are of interest in geometric design:

- Stopping sight distance;
- Meeting sight distance;
- Passing sight distance.

Stopping Sight Distance:

The Stopping sight distance comprises two elements: d_1 = the distance moved from the instant the object is sighted to the moment the brakes are applied (the perception and brake reaction time, referred to as the total reaction time) and d_2 = the distance traversed while braking (the braking distance).

The total reaction time depends on the physical and mental characteristics of the driver, atmospheric visibility, types and condition of the road and distance to, size color and shape of the hazard. When drivers are keenly as in urban conditions with high traffic intensity, the reaction time may be in the range of 0.5 – 1.0 seconds while driver reaction time is generally around 2 – 4

seconds for normal driving in rural conditions. Overseas Road Note 6 assumes a total reaction time of 2 sec.

The distance traveled before the brakes are applied is:

$$d_1 = 10/36 * V * t$$

where:

- d_1 = total reaction distance in m;
- V = initial vehicle speed in Km/h
- t = reaction time in sec.

The braking distance, d_2 , is dependent on vehicle condition and characteristics, the coefficient of friction between tyre and road surface, the gradient of the road and the initial vehicle speed.

$$d_2 = V^2 / (254(f + g/100))$$

where:

- d_2 = breaking distance in meters;
- V = initial vehicle speed in km/h;
- f = coefficient of longitudinal friction;
- g = gradient(in %; positive if uphill and negative if downhill)

The determination of design values of longitudinal friction, f , is complicated because of the many factors involved. The design values for longitudinal friction used in Overseas Road Note 6 are shown in table 3.2.

Table 3.2 Coefficient of Longitudinal friction

Design speed (Km/h)	30	40	50	60	70	85	100	120
f	0.60	0.55	0.50	0.47	0.43	0.40	0.37	0.35

Meeting Sight Distance:

Meeting sight distance is the distance required to enable the drivers of two vehicles traveling in opposite directions to bring their vehicles to a safe stop after becoming visible to each other. Meeting sight distance is normally calculated as twice the minimum stopping sight distance.

Passing Sight Distance:

Factors affecting passing (overtaking) sight distance are the judgment of overtaking drivers, the speed and size of overtaken vehicles, the acceleration capabilities of overtaking vehicles, and the speed of oncoming vehicles.

Passing sight distances are determined empirically and are usually based on passenger car requirements. There are differences in various standards for passing sight distance due to different assumptions about the component distances in which a passing maneuver can be divided, different assumed speed for the maneuver and, to some extent driver behavior.

The passing sight distances recommended for use by Overseas Road Note 6 are shown in table 3.3.

Table 3.3 Passing sight distances

Design speed (Km/h)	50	60	70	85	100	120
Passing sight distance(m)	140	180	240	320	430	590

Traffic Volume

Information on traffic volumes, traffic composition and traffic loading are important factors in the determination of the appropriate standard of a road. The traffic has a major impact on the selection of road class, and consequently on all geometric design elements. The traffic information is furthermore necessary for the pavement design.

For low volume roads the design control is the Average Annual Daily Traffic (AADT) in the 'design year'. For routes with large seasonal variations the design control is the Average Daily Traffic (ADT) during the peak months of the 'design year'. The design year is usually selected as year 10 after the year of opening to traffic.

Design Vehicle

The dimensions of the motor vehicles that will utilize the proposed facility also influence the design of a roadway project. The width of the vehicle naturally affects the width of the traffic lane; the vehicle length has a bearing on roadway capacity and affects the turning radius; the vehicle height affects the clearance of the various structures. Vehicle weight affects the structural design of the roadway.

The design engineer will select for design the largest vehicle that is expected to use the roadway facility in significant numbers on a daily basis.

Geometric Design Elements

The basic elements of geometric design are: the horizontal alignment, the vertical alignment and the cross-section. The following elements must be considered when carrying out the geometric design of a road:

1. Horizontal Alignment:
 - Minimum curve radius (maximum degree of curvature);
 - Minimum length of tangent between compound or reverse curves;
 - Transition curve parameters;
 - Minimum passing sight distance and stopping sight distance on horizontal curves.
2. Vertical Alignment:
 - Maximum gradient;
 - Length of maximum gradient;

- Minimum passing sight distance or stopping sight distance on summit (crest) curves;
 - Length of sag curves.
3. Cross-section:
- Width of carriageway;
 - Crossfall of carriageway;
 - Rate of super elevation;
 - Widening of bends;
 - Width of shoulder;
 - Crossfall of shoulder;
 - Width of structures;
 - Width of right-of-way;
 - Sight distance;
 - Cut and fill slopes and ditch cross-section.

Horizontal and vertical alignment should not be designed independently. They complement each other and proper combination of horizontal and vertical alignment, which increases road utility and safety, encourages uniform speed, and improves appearance, can almost always be obtained without additional costs.

3.3 Horizontal Alignment

The horizontal alignment should always be designed to the highest standard consistent with the topography and be chosen carefully to provide good drainage and minimize earthworks. The alignment design should also be aimed at achieving a uniform operating speed. Therefore the standard of alignment selected for a particular section of road should extend throughout the section with no sudden changes from easy to sharp curvature. Where a sharp curvature is unavoidable, a sequence of curves of decreasing radius is recommended.

The horizontal alignment consists of a series of intersecting tangents and circular curves, with or without transition curves.

Straights (Tangents)

Long straights should be avoided, as they are monotonous for drivers and cause headlight dazzle on straight grades. A more pleasing appearance and higher road safety can be obtained by a winding alignment with tangents deflecting some 5 – 10 degrees alternately to the left and right. Short straights between curves in the same direction should not be used because of the broken back effect. In such cases where a reasonable tangent length is not attainable, the use of long, transitions or compound curvature should be considered.

The following guidelines may be applied concerning the length of straights:

- Straights should not have lengths greater than $(20 * V)$ meters, where V is the design speed in km/h.
- Straights between circular curves turning in the same direction should have lengths greater than $(6*V)$ meters, where V is the design speed in km/h.

- Straights between the end and the beginning of untransitioned reverse circular curves should have lengths greater than two-thirds of the total superelevation run-off.

Circular Curves

Horizontal curvature design is one of the most important features influencing the efficiency and safety of a highway. Improper design will result in lower speeds and lowering of highway capacity.

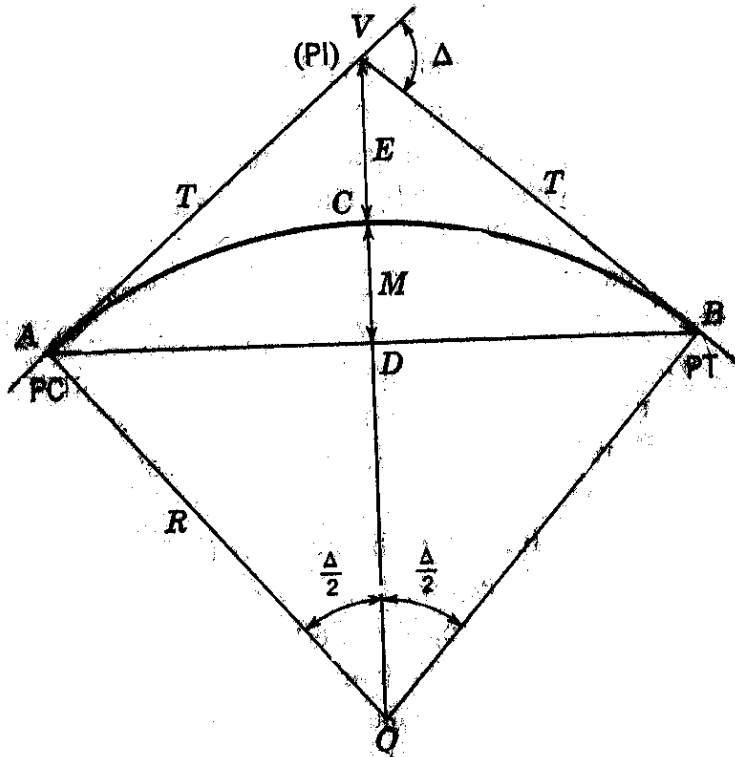

Figure 3.1. Parts of a Circular Curve

Note:

- PC – point of curvature
- PI – point of intersection
- PT – point of tangency
- Δ – central angle
- R – radius of curve
- D – degree of curve that defines,
 - Central angle which subtends 20m arc (arc definition),
 - Central angle which subtends 20m chord (Chord definition)

From arc definition,

$$R = 1145.916 / D$$

From chord definition,

$$R = 10 / \sin(D/2)$$

- Tangent (T): distance from PC to PI(backward tangent) or from PT to PI(forward tangent)

$$T = R \cdot \tan(\Delta/2)$$

- External distance (E): distance from PI to middle of curve.

$$E = R \cdot (\sec(\Delta/2) - 1) \quad \text{Or} \quad E = T \cdot \tan(\Delta/4)$$

- Middle ordinate (M): length from the middle of chord to the middle of curve.

$$M = R \cdot (1 - \cos(\Delta/2))$$

- Long chord(C): straight-line distance from A to B.

$$C = 2R \cdot \sin(\Delta/2)$$

- Length of Curve (L_c): distance from PC to PT along the curve.

$$L_c = 20 \cdot \Delta/D \quad \text{Or} \quad L_c = R \cdot \pi \cdot \Delta/180$$

- Sub-arc angles d_i : are angles subtended by an arc less than the degree of curve (D).

$$d_i = A_i \cdot D/20$$

where:

d_i = angle subtended by sub-arc of length A_i

A_i = arc less than 20m.

- Sub chord angle (d_j): are angles subtended by a chord less than the degree of curve (D).

$$c_j = 2R \cdot \sin(d_j/2)$$

Also

$$c_j = 20 \sin(d_j/2) / \sin(D/2)$$

Where:

d_j = angle subtended by sub-chord of length c_j

c_j = chord less than 20m.

- Deflection angles: The angle that a chord deflects from a tangent to a circular curve is measured by half of the intercepted arc.

- Deflection angle for L_c $m = \Delta/2$

- Deflection angle for 20m $m = D/2$

- Deflection angle for A_i $m = d_i/2$

- Stations of PC, PI, and PT:

$$PC = PI - T$$

$$PT = PC + L_c \quad \text{or} \quad PT = PI + T$$

Several variations of the circular curve deserve consideration when developing the horizontal alignment for a highway design. When two curves in the same direction are connected with a short tangent, this condition is referred to as a “broken back” arrangement of curves. This type of alignment should be avoided except where very unusual topographical or right-of-way conditions dictate otherwise. Highway engineers generally consider the broken back alignment to be unpleasant and awkward and prefer **spiral transitions** or a **compound curve** alignment with continuous superlevation for such conditions.

Figure 3.2 identifies elements of a typical compound highway curve with variable definitions and basic equations developed for a larger and smaller radius curve, based on the assumption that the radius dimensions R_L and R_S and central angles Δ_L and Δ_S are given or have been previously determined.

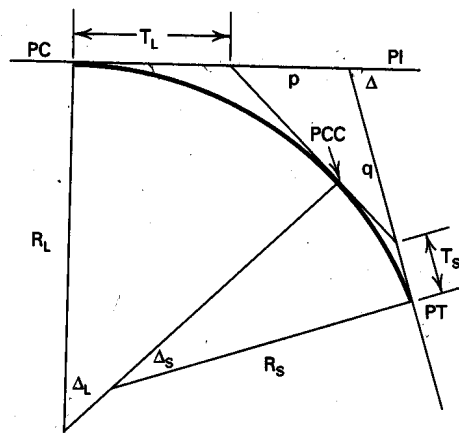

VARIABLES

- R_L = Large curve radius
- R_S = Small curve radius
- Δ_L = Central angle of large radius curve
- Δ_S = Central angle of small radius curve
- Δ = Central angle or intersection angle
- LT = Long tangent
- ST = Short tangent

BASIC EQUATIONS FOR A COMPOUND CURVE (2-CENTERED)

$$\Delta = \Delta_L + \Delta_S$$

$$T_L = R_L \tan \frac{\Delta_L}{2}$$

$$T_S = R_S \tan \frac{\Delta_S}{2}$$

$$LT = T_L + p$$

$$ST = T_S + q$$

$$\frac{p}{\sin \Delta_S} = \frac{T_L + T_S}{\sin (180 - \Delta)} = \frac{q}{\sin \Delta_L}$$

Figure 3.2 Properties of a Compound Curve

Another important variation of the circular highway curve is the use of **reverse curves**, which are adjacent curves that curve in opposite directions. The alignment illustrated in figure 3.3, which shows a point of reverse curvature, PRC, and no tangent separating the curves, would be suitable only for low-speed roads such as those in mountainous terrain. A sufficient length of tangent between the curves should usually be provided to allow removal of the superelevation from the first curve and attainment of adverse superelevation for the second curve.

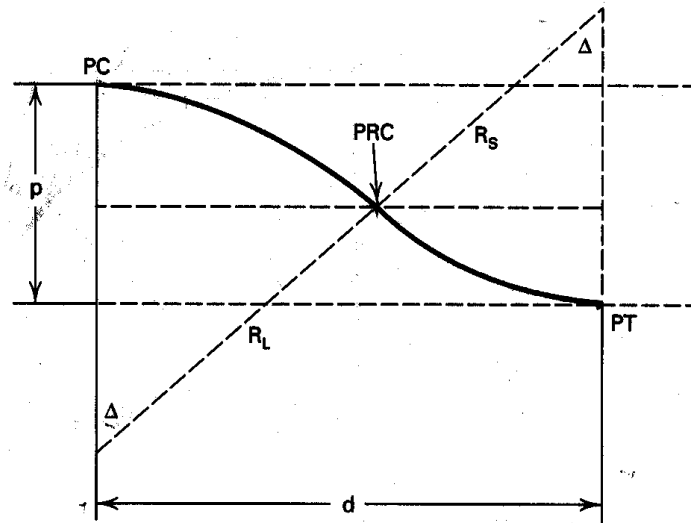

VARIABLES

R_L = Large curve radius

R_S = Small curve radius

PRC = Point of reverse curve

Δ = Central angle of each curve

p = Offset distance

d = Tangent distance

REVERSE CURVE EQUATIONS

$$p = (R_L + R_S)(1 - \cos \Delta)$$

$$d = (R_L + R_S) \sin \Delta$$

$$\tan \frac{\Delta}{2} = \frac{p}{d}$$

Figure 3.3 Properties of a Reverse Curve

Sight Distance on Horizontal Curves:

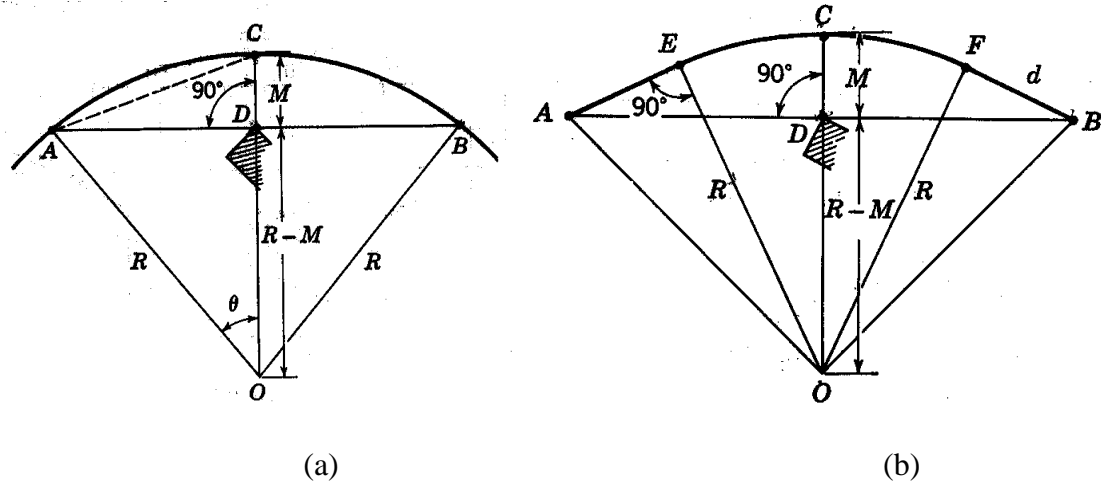

Figure 3.4 Sight Distance Around Horizontal Curve: (a) $S < L_c$ and (b) $S > L_c$

Situations frequently exist where an object on the inside of a curve, such as vegetation, building or cut face, obstructs the line of sight. Where it is either not feasible or economically justified to move the object a larger radius of curve will be required to ensure that stopping sight distance is available. The required radius of curve is dependent on the distance of the obstruction from the centerline and the sight distance.

Case 1. $S < L_c$

$$S = 40 * \cos^{-1} ((R-M)/R) / D$$

Case 2. $S > L_c$

$$M = L_c * (2S - L_c) / 8R$$

Night driving around sharp curves introduces an added problem related to horizontal sight distance. Motor-vehicle headlights are pointed directly toward the front and do not provide as much illumination in oblique directions. Even if adequate horizontal sight distance is provided, it has little useful purpose at night because the headlights are directed along a tangent to the curve, and the roadway itself is not properly illuminated.

Superelevation

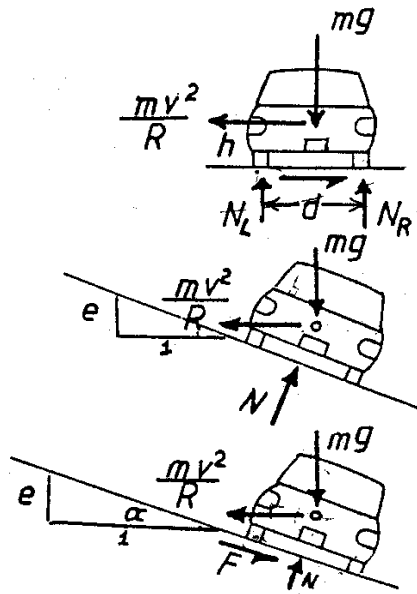

Figure 3.5 Forces acting on a vehicle moving along a curved path.

Anybody moving rapidly along a curved path is subject to an outward reactive force called the centrifugal force. If the surface is flat, the vehicle is held in the curved path by side friction between tires and pavement. The total of these friction forces balances the centrifugal force. Expressed in terms of the coefficient of friction f and the normal forces between the pavement and the tires, the relationship is

$$m \cdot v^2 / R = (N_L + N_R) \cdot f = m \cdot g \cdot f$$

or

$$f = v^2 / (g \cdot R)$$

When velocity v (m/s) is stated in V (Km/h), and the radius of curve(R) in meters, the equation reduces to

$$f = V^2 / (127 \cdot R)$$

On highway curves, this centrifugal force acts through the center of mass of the vehicle and creates an overturning moment about the points of contact between the outer wheels and the pavement. But a stabilizing (resisting) moment is created by the weight acting through the center of mass. Thus for equilibrium conditions,

$$(m \cdot v^2 / R) \cdot h = m \cdot g \cdot d / 2$$

and

$$h = d / (2v^2 / gR) = d / 2f$$

where

h = height of the center of mass above pavement

d = lateral width between the wheels

For the moment equation, if $f = 0.5$, then the height to the center of mass must be greater than the lateral distance between the wheels before overturning will take place. Modern passenger vehicles have low center of mass so that relatively high values of f have to be developed before overturning would take place. In practice, the frictional value is usually sufficiently low for sliding to take place before overturning. It is only with certain commercial vehicles having high center of mass that the problem of overturning may arise.

In order to resist the outward acting centrifugal force, and to enable vehicles to round curves at design speed without discomfort to their occupants, the pavements are “**tilted**” or “**superelevated**” so that the outer edges are higher than the inner edges. This tilting, plus

frictional resistance between the tires and the pavement provides a horizontal resistance to the centrifugal forces generated by the circular movement of the vehicle around a curve.

Analysis of the forces acting on a vehicle as it moves around a curve of constant radius indicates that the theoretical superelevation can be expressed as:

$$e + f = V^2 / (127 * R) \dots\dots\dots (*)$$

where:

e = rate of superelevation(m per m)

f = side friction factor (or coefficient of lateral friction)

V = speed (Km/hr)

R = radius of curvature (m)

Equation (*) above is the basic equation relating the speed of vehicles, the radius of curve, the superelevation and the coefficient of lateral friction. This equation forms the basis of design of horizontal curves.

If the entire centrifugal force is counteracted by the superelevation, frictional force will not be called into play. Proper design does not normally take full advantage of the obtainable lateral coefficients of friction, since the design should not be based on a condition of incipient sliding. In design, engineers use only a portion of the friction factor, accounting for the comfort and safety of the vast majority of drivers.

From equation (*), the minimum radius or maximum degree of curvature for a given design speed can be determined from the rate of superelevation and side friction factor.

$$R = V^2 / (127 * (e + f))$$

$$D = 1145.916 / R$$

Attainment of Superelevation:

The transition from a tangent, normal crown section to a curved superelevated section must be accompanied without any appreciable reduction in speed and in such a manner as to ensure safety and comfort to the occupants of the traveling vehicle.

The normal cambered surface on a straight reach of road is changed into a superelevated surface into two stages. In the first stage, the outer half of the camber is gradually raised until it is level. In the second stage, three methods may be adopted to attain the full super-elevation.

- i. The surface of the road is rotated about the centerline of the carriageway, gradually lowering the inner edge and raising the upper edge, keeping the level of the centerline constant.
- ii. The surface of the road is rotated about the inner edge, raising the center and the outer edge.
- iii. The surface of the road is rotated about the outer edge depressing the center and the outer edge.

Method (i) is the most generally used.

The distance required for accomplishing the transition from a normal to a superelevated section, commonly referred to as the **transition runoff**, is a function of the design speed and the rate of superelevation.

Superelevation is usually started on the tangent at some distance before the curve starts, and the full superelevation is generally reached beyond the point of curvature (PC) of the curve. In curves with transitions, the superelevation can be attained within the limits of the spiral.

Value of Coefficient of Lateral Friction:

The value of coefficient of lateral friction depends upon a number of factors, chief among them being the vehicle speed, type and condition of roadway surfaces, and type and condition of the tyres.

Table 3.4 Coefficient of Lateral Friction as Recommended by AASHTO

Design Speed (Km/hr)	50	65	80	100	120	130
Maximum f	0.16	0.15	0.14	0.13	0.12	0.11

Table 3.5 Coeff. Of Lateral Friction as Recommended by TRRL Overseas Road Note 6

Design Speed(Km/hr)	30	40	50	60	70	85	100	120
f	0.33	0.30	0.25	0.23	0.20	0.18	0.15	0.15

Maximum Super-elevation Value:

If eqn (*) is to be used for design, it is desirable to know the maximum super-elevation that can be permitted. Practice in this regard varies from country to country.

According to Transport Construction Design Enterprise (TCDE):

- $e_{\max} = 10\%$
- $f_{\max} = 0.16$

Transition Curves

Transition curves provide a gradual change from the tangent section to the circular curve and vice versa. For most curves, drivers can follow a transition path within the limits of a normal lane width, and a spiral transition in the alignment is not necessary. However, along high-speed roadways with sharp curvature, transition curves may be needed to prevent drivers from encroaching into adjoining lanes.

A curve known as the Euler spiral or clothoid is commonly used in highway design. The radius of the spiral varies from infinity at the tangent end to the radius of the circular arc at the end of the spiral. The radius of the spiral at any point is inversely proportional to the distance from its beginning point.

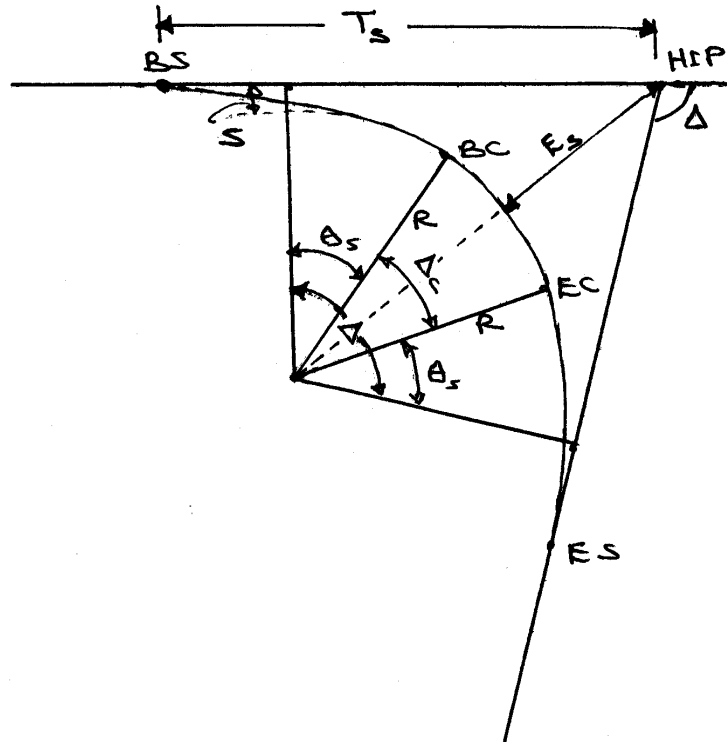

Figure 3.6 Main Elements of A Circular Curve Provided with Transitions

Some of the important properties of the spirals are given below:

- $L = 2R\theta$
- $\theta = (L / L_s)^2 * \theta_s$
- $\theta_s = L_s / 2R_c$ (in radians) = $28.65L_s / R_c$ (in degrees)
- $T_s = L_s / 2 + (R_c + S) * \tan(\Delta/2)$
- $S = L_s^2 / 24R_c$
- $E_s = (R_c + S) * \sec(\Delta/2) - R_c$

Note:

θ_s = spiral angle

Δ = total central angle

Δ_c = central angle of the circular arc extending from BC to EC = $\Delta - 2\theta_s$

R_c = radius of circular curve

L = length of spiral from starting point to any point

R = radius of curvature of the spiral at a point L distant from starting point.

T_s = tangent distance

E_s = external distance

S = shift

HIP = horizontal intersection point

BS = beginning of spiral
 BC = beginning of circular curve
 EC = end of circular curve
 ES = end of spiral curve

Length of Transition:

The length of transition should be determined from the following two conditions:

- The rate of change of centrifugal acceleration adopted in the design should not cause discomfort to the drivers. If C is the rate of change of acceleration,

$$L_s = 0.0215V^3 / (C \cdot R_c)$$

Where:

V = speed (Km/hr)

R_c = radius of the circular curve (m)

- The rate of change of superelevation (superelevation application ratio) should be such as not to cause higher gradients and unsightly appearances. Since superelevation can be given by rotating about the centerline, inner edge or outer edge, the length of the transition will be governed accordingly.

Widening of Curves

Extra width of pavement may be necessary on curves. As a vehicle turns, the rear wheels follow the front wheels on a shorter radius, and this has the effect of increasing the width of the vehicle in relation to the lane width of the roadway. Studies of drivers traversing curves have shown that there is a tendency to drive a curved path longer than the actual curve, shifting the vehicle laterally to the right on right-turning curves and to the left on left-turning curves. Thus, on right-turning curves the vehicle shifts toward the inside edge of the pavement, creating a need for additional pavement width. The amount of widening needed varies with the width of the pavement on tangent, the design speed, and the curve radius or degree of curvature.

The widening required can be calculated from

$$W_e = n \cdot B^2 / 2R + V / 10 \sqrt{R}$$

Where:

W_e = total widening

B = wheel base

R = radius of curve

V = design speed (Km/hr)

n = number of lanes

3.4 Vertical Alignment

The vertical alignment of the roadway and its effect on the safe, economical operation of the motor vehicle constitute one of the most important features of a highway design. The vertical alignment, which consists a series of straight profile lines connected by vertical parabolic curves, is known as the profile grade line. When the profile grade line is increasing from a level or flat

alignment, this condition is referred to as a “plus grade”, and when the grade is decreasing from a level alignment, the grade is termed a “minus grade”. In analyzing grade and grade controls, the designer usually studies the effect of change on the centerline profile of the roadway.

In the establishment of a grade, an ideal situation is one in which the cut is balanced against the fill without a great deal of borrow or an excess of cut material to be wasted. All earthwork hauls should be moved in a downhill direction if possible and within a relatively short distance from the origin, due to the expense of moving large quantities of soil. Ideal grades have long distances between points of intersection, with long curves between grade tangents to provide smooth riding qualities and good visibility. The grade should follow the general terrain and rise or fall in the direction of the existing drainage. In rock cuts and in flat, low-lying or swampy areas, it is necessary to maintain higher grades with respect to the existing ground line. Future possible construction and the presence of grade separations or bridge structures can also act as control criteria for the design of a vertical alignment.

Grades and Grade Control

Changes of grade from plus to minus should be placed in cuts, and changes from a minus grade to a plus grade should be placed in fills. This will generally give a good design, and many times it will avoid the appearance of building hills and producing depressions contrary to the general existing contours of the land. Other considerations for determining the grade line may be of more importance than the balancing of cuts and fills.

In the analysis of grades and grade control, one of the most important considerations is the effect of grades on the operating costs of the motor vehicle. An increase in gasoline consumption, a reduction in speed, and an increase in emissions and noise are apparent when grades are increased. An economical approach would be to balance the added cost of grade reduction against the annual costs and impacts of vehicle operation without grade reduction. An accurate solution to the problem depends on the knowledge of traffic volume and type, which can be obtained by means of a traffic survey.

Minimum grades are governed by drainage conditions. Level grades may be used in fill sections in rural areas when crowned pavements and sloping shoulders can take care of the pavement surface drainage. However, it is preferred that the profile grade be designed to have a minimum grade of at least 0.3 percent under most conditions in order to secure adequate drainage.

Vertical Curves

The parabolic curve is used almost exclusively in connecting profile grade tangents. The primary reason for the use of this type of curve in vertical highway alignments is the convenient manner in which the vertical offsets can be computed and the smooth transitions created from tangent to curve and then back to tangent. When a vertical curve connects a positive grade with a negative grade, it is referred to as a “crest curve”. Likewise, when a vertical curve connects a negative grade with a positive grade, it is termed a “sag curve”. Various configurations of crest and sag curves are illustrated in figure 3.7. Various definitions and basic equations for a typical vertical curve are presented in figure 3.8. The sign conventions for g_1 and g_2 allow the use of the same formulas in the calculation of offsets and elevations for a sag curve also.

All distances along vertical curves are measured horizontally, and all offsets from the tangents to the curve are measured vertically. Accordingly, the length of a vertical curve is its horizontal projection. The error resulting from this assumption is negligible in practice since the curve is quite flat. Unless otherwise defined, vertical curves are symmetrical in the sense that the tangents are equal in length.

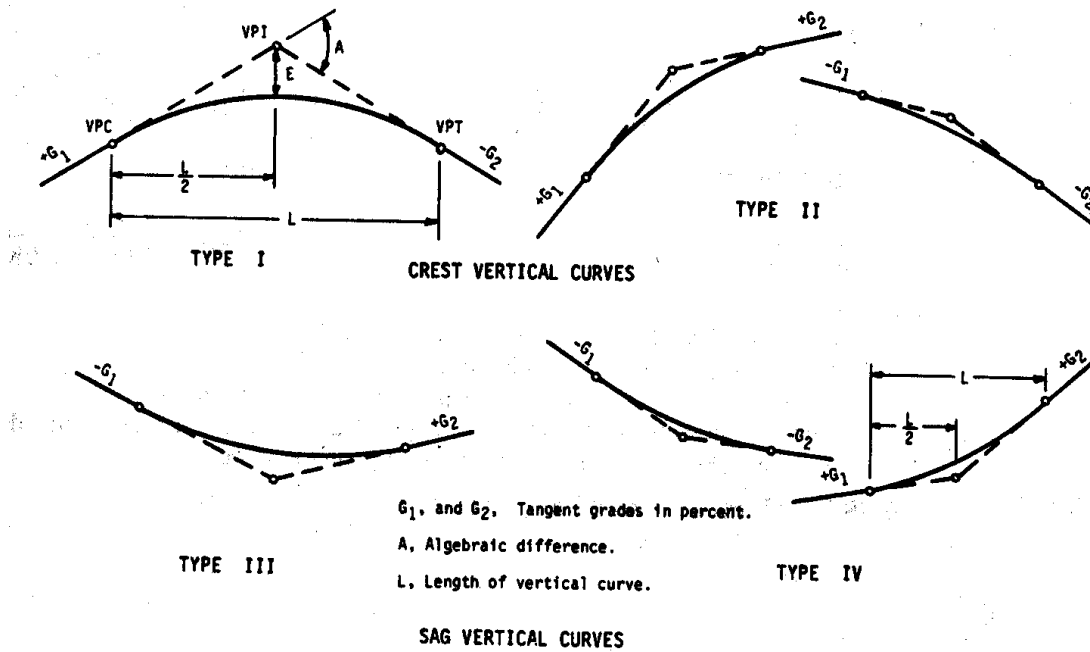
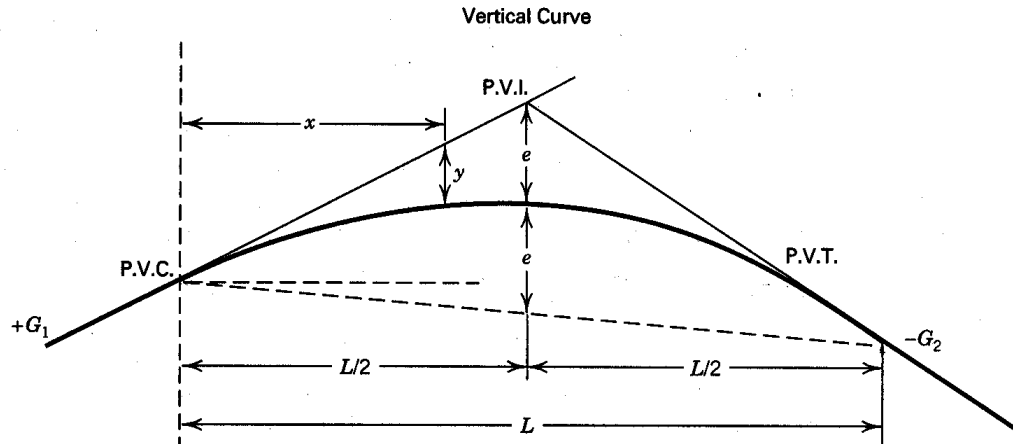

Figure 3.7 Types of crest and sag vertical curves



VARIABLES

VPI = Vertical point of intersection

VPC = Vertical point of curvature

VPT = Vertical point of tangency

G_1 = Grade of initial tangent

G_2 = Grade of final tangent

L = Length of vertical curve

A = Algebraic difference in grade between g_1 and g_2

K = Vertical curve length coefficient as determined for stopping sight distance

x = Horizontal distance to point on curve, measured from VPC

E_x = Elevation of point on curve located at distance x from VPC

x_m = Location of min/max point on curve, measured from VPC

E_m = Elevation of min/max point on curve at distance x_m from VPC

e = External distance = middle ordinate

y = Offset of curve from initial grade line

E_{PI} = Elevation of VPI

E_{PC} = Elevation of VPC

E_{PT} = Elevation of VPT

g_1 = Grade of initial tangent in percent

g_2 = Grade of final tangent in percent

VERTICAL CURVE EQUATIONS

$$A = g_2 - g_1$$

$$K = \frac{L}{A}$$

$$e = \frac{(G_1 - G_2)L}{8} = \frac{AL}{800} = \frac{A^2 K}{800}$$

For high (low) point on curve,

$$x_m = \frac{g_1 L}{g_2 - g_1} = \frac{g_1 L}{A}$$

For any point p on curve,

$$y = \frac{(G_2 - G_1)x^2}{2L} = \frac{A x^2}{200L} = \frac{x^2}{200K}$$

$$E_x = E_{PC} + G_1 x + \frac{(G_2 - G_1)x^2}{2L}$$

similarly,

$$E_x = E_{PC} + \frac{g_1 x}{100} + \frac{x^2}{200K}$$

Figure 3.8 Properties of a typical vertical curve

Length of Vertical Curves

A. Crest Curves:

For crest curves, the most important consideration in determining the length of the curve is the sight distance requirement.

Case 1: $S < L$

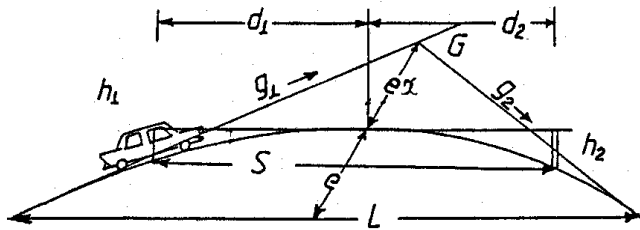

$$L = \frac{GS^2}{(\sqrt{2h_1} + \sqrt{2h_2})^2}$$

Case 2: $S > L$

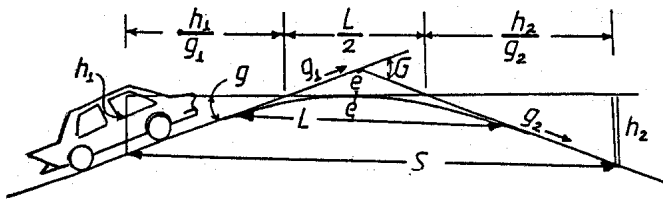

$$L = 2 * S - \frac{2(\sqrt{h_1} + \sqrt{h_2})^2}{G}$$

AASHTO recommendations:

- For stopping sight distance over crest: $h_1 = 1.07\text{m}$ and $h_2 = 0.15\text{m}$
- For passing sight distance over crest: $h_1 = 1.07\text{m}$ and $h_2 = 1.30\text{m}$

B. Sag Curves:

For sag curves, the criteria for determining the length are vehicle headlight distance, rider comfort, drainage control and general appearance.

B.1 Headlight Sight Distance:

Case 1: $S < L$

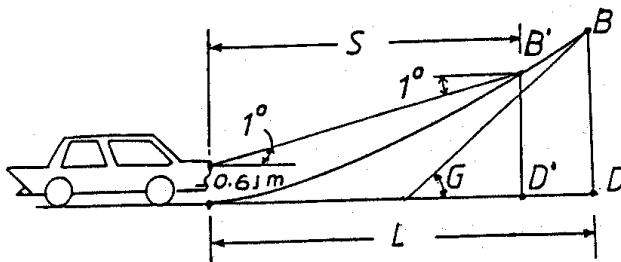

$$L = \frac{S^2 G}{1.22 + 0.035 * S}$$

Case 2: $S > L$

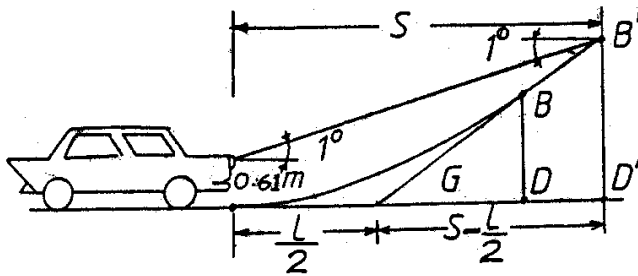

$$L = 2S - \left(\frac{1.22 + 0.035 * S}{G} \right)$$

B.2 Comfort

There is still a considerable difference of opinion as to what value of radial acceleration should be used on vertical curves for comfort purposes. The most commonly quoted values are between 0.30 and 0.46m/s², but lesser values are preferred. If the vertical radial acceleration is assumed to be equal to a_r (in m/s²), then

$$L = \frac{V^2 G}{13 a_r}$$

V - Speed in Km/hr

Sight Distances at Underpass Structures:

Case 1: S < L

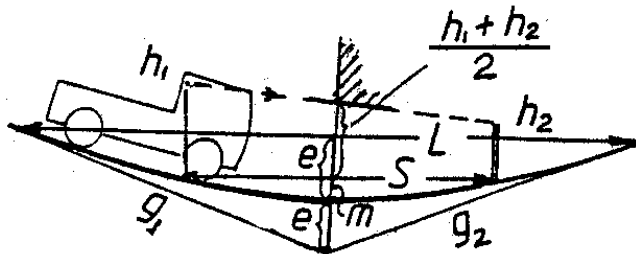

$$L = \frac{S^2 G}{8m}$$

where:
 $m = C - (h_1 + h_2)/2$
 C = Vertical clearance

Case 2: S > L

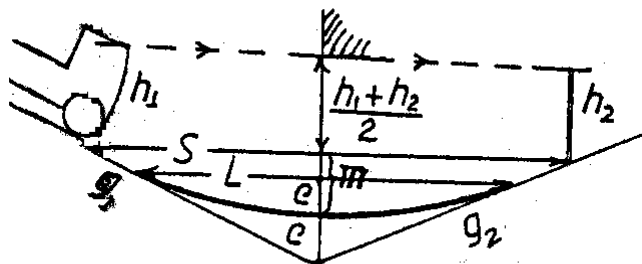

$$L = 2S - \frac{8m}{G}$$

- AASHTO recommendations: h₁ = 1.829m, h₂ = 0.457m and C = 5.182m

3.5 Cross-Section

The cross-sectional elements in a highway design pertain to those features that deal with its width. They embrace aspects such as right-of-way, roadway width, central reservations (medians), shoulders, camber, side-slope etc.

Right- Of –Way

The right-of-way width is the width of land secured and preserved to the public for road purposes. The right-of-way should be adequate to accommodate all the elements that make up the cross-section of the highway and may reasonably provide for future development.

Road Width

Road width should be minimized so as to reduce the costs of construction and maintenance, whilst being sufficient to carry the traffic loading efficiently and safely.

The following factors need to be taken into account when selecting the width of a road:

1. **Classification of the road.** A road is normally classified according to its function in the road network. The higher the class of road, the higher the level of service expected and the wider the road will need to be.
2. **Traffic.** Heavy traffic volumes on a road mean that passing of oncoming vehicles and overtaking of slower vehicles are more frequent and therefore that paths of vehicles will be further from the center-line of the road and the traffic lanes should be wider.
3. **Vehicle dimensions.** Normal steering deviations and tracking errors, particularly of heavy vehicles, reduce clearances between passing vehicles. Higher truck percentages require wider traffic lanes.
4. **Vehicle speed.** As speeds increase, drivers have less control of the lateral position of vehicles, reducing clearances, and so wider traffic lanes are needed.

Figure 3.9 shows the typical cross-sections recommended by Overseas Road Note 6, for the various road design classes A – F.

The cross-section of the road is usually maintained across culverts, but special cross-sections may need to be designed for bridges, taking into account traffic such as pedestrians, cyclists, etc., as well as motor traffic. Reduction in the carriageway width may be accepted, for instance, when an existing narrow bridge has to be retained because it is not economically feasible to replace or widen it. It may also sometimes be economic to construct a superstructure of reduced width initially with provision for it to be widened later when traffic warrants it. In such cases a proper application of traffic signs, rumble strips or speed bumps is required to warn motorists of the discontinuity in the road.

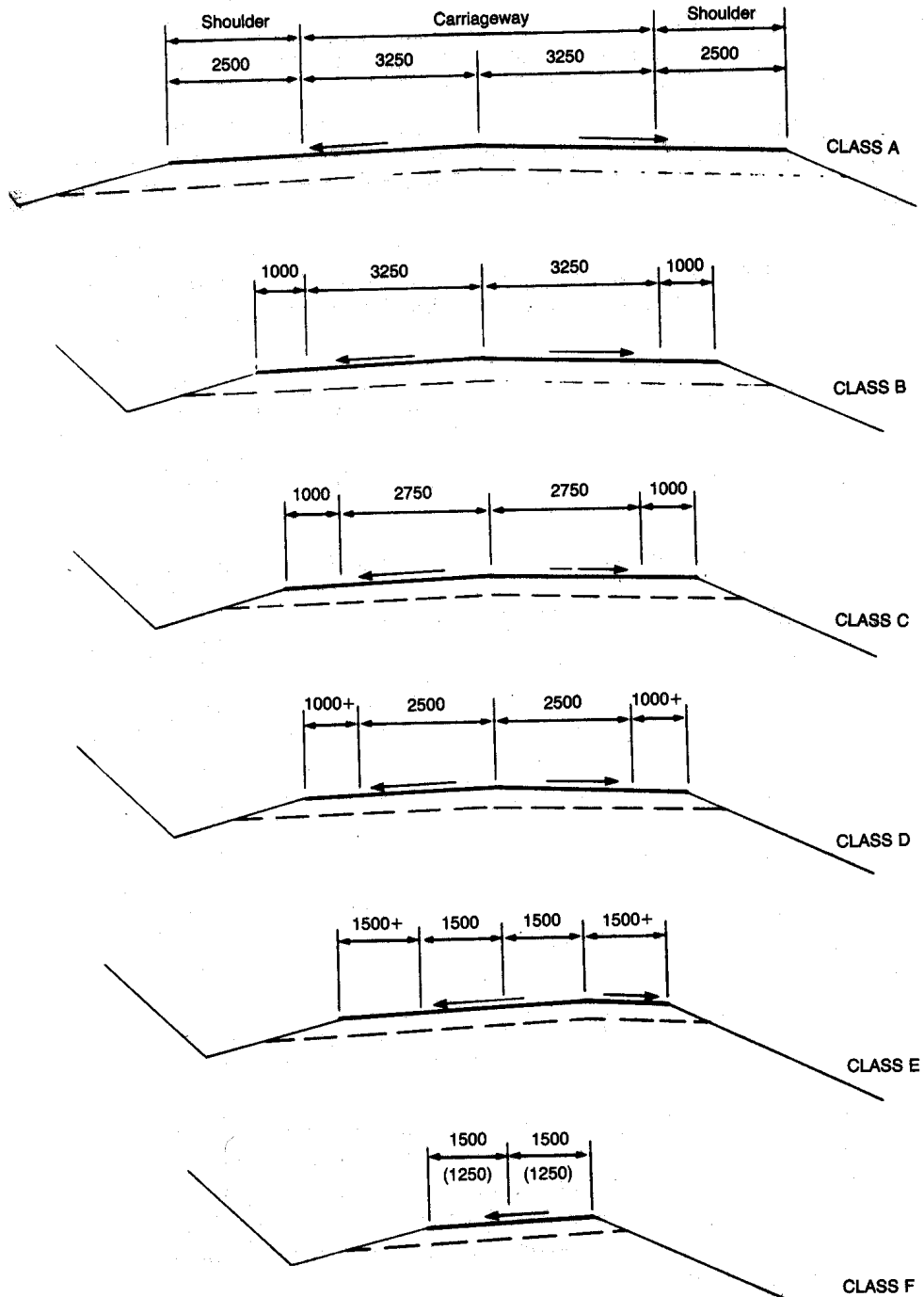

- 1) Dimensions are in mm.
- 2) Widths should be considered as minimum values and widening is required on curves with tighter radii.
- 3) Single-lane roads (classes E and F) require meeting sight distance.
- 4) For a high percentage of heavy vehicles (>40%) it is advisable to increase the running surface width for classes C, D, E and F by 0.50 m.

Figure 3.9 Typical cross-sections (TRRL Overseas Road Note 6)

For single-lane roads without shoulders passing places must be provided to allow passing and overtaking. The total road width at passing places should be a minimum of 5.0m but preferably

5.5m, which allows two trucks to pass safely at low speed. The length of individual passing places will vary with local conditions and the sizes of vehicles in common use but, generally, a length of 20m including tapers will cater for trucks with a wheelbase of 6.5m and an overall length of 11.0m.

Normally, passing places should be located every 300-500m depending on the terrain and geometric conditions. They should be located within sight distance of each other and be constructed at the most economic locations as determined by terrain and ground conditions, such as at transitions from cut to fill, rather than at precise intervals.

Shoulders

Shoulders provide for the accommodation of stopped vehicles. Properly designed shoulders also provide an emergency outlet for motorists finding themselves on a collision course and they also serve to provide lateral support to the carriageway. Further, shoulders improve sight distances and induce a sense of 'openness' that improves capacity and encourages uniformity of speed.

In developing countries shoulders are used extensively by non-motorized traffic (pedestrians, bicycles and animals) and a significant proportion of the goods may be transported by such non-motorized means.

Cross-Fall

Two-lane roads should be provided with a camber consisting of a straight-line cross-fall from the center-line to the carriageway edges, while straight cross-fall from edge to edge of the carriageway is used for single-lane roads and for each carriageway of divided roads.

The cross-fall should be sufficient to provide adequate surface drainage whilst not being so great as to be hazardous by making steering difficult. The ability of a surface to shed water varies with its smoothness and integrity. On unpaved roads, the minimum acceptable value of cross-fall should be related to the need to carry surface water away from the pavement structure effectively, with a maximum value above which erosion of a material starts to become a problem.

According to Overseas Road Note 6 the normal cross-fall should be 3% on paved roads and 4 – 6% on unpaved roads.

Due to the action of traffic and weather the cross-fall of unpaved roads will gradually be reduced and rutting may develop. To avoid the rutting developing into potholes a cross-fall of 5 – 6% should be reestablished during the routine and periodic maintenance works.

Shoulders having the same surface as the carriageway should have the same cross-slope. Unpaved shoulders on a paved road should be about 2% steeper than the cross-fall of the carriageway.

Side Slopes

The slopes of fills (embankments) and cuts must be adapted to the soil properties, topography and importance of the road. Earth fills of common soil types and usual height may stand safely on slopes of 1 on 1.5 and slopes of cuts through undisturbed earth with cementing properties remain in place with slopes of about 1 on 1. Rock cuts are usually stable at slopes of 4 on 1 or even steeper depending on the homogeneity of the rock formation and direction of possible dips and strikes.

Using these relatively steep slopes will result in minimization of earthworks, but steep slopes are, on the other hand, more liable to erosion than flatter slopes as plant and grass growth is hampered and surface water velocity will be higher. Thus the savings in original excavation and embankment costs may be more than offset by increased maintenance through the years.

CHAPTER 4

4 EARTHWORK COMPUTATIONS

4.1 Introduction

The term earthwork includes all clearing, grubbing, roadway and drainage excavation, excavation for structures, embankments, borrow, overhaul, machine grading, subgrade scarifying, rock fill, and all the operations of preparing the subgrade foundation for highway or runway pavement. The quantity and cost of earthwork are calculated in terms of cubic meters of excavation in its original position on the basis of cross-section notes from field measurements. Modern grading operations are carried on by power equipment including power shovels, scrapers, bulldozers, blade graders, rollers, dragline excavators, motor trucks, tractors, etc.

Classification of Excavated Material

Excavated material is usually classified as (1) common excavation, (2) loose rock, or (3) solid rock. Common excavation is largely earth, or earth with detached boulders less than ½ cu yd. Loose rock usually refers to rock which can be removed with pick and bar, although the use of power shovels or blasting may be advantageous. Solid rock comprises hard rock in place and boulders that can be removed only by the use of drilling and blasting equipment.

Shrinkage and Swell Factors

When earth is excavated and hauled to form an embankment, the freshly excavated material generally increases in volume. However, during the process of building the embankment it is compacted, so that the final volume is less than when in its original condition. This difference in volume is usually defined as “shrinkage”. In estimating earthwork quantities, it is necessary to make allowance for this factor. The amount of shrinkage varies with the soil type and the depth of the fill. An allowance of 10 to 15 percent is frequently made for high fills and 20 to 25 percent for shallow fills. The shrinkage may be as high as 40 or 50 percent for some soils. This generally also allows for shrinkage due to loss of material in the hauling process.

When rock is excavated and placed in the embankment, the material will occupy a larger volume. This increase is called “swell” and may amount to 30 percent or more.

Percent shrinkage = $(1 - (\text{wt. bank measure} / \text{wt. compacted})) * 100$

$$\% \text{ sh.} = (1 - (\gamma_B / \gamma_C)) * 100 \quad \dots\dots\dots(1)$$

Percent swell = $((\text{wt. bank measure} / \text{wt. loose measure}) - 1) * 100$

$$\% \text{ sw.} = ((\gamma_B / \gamma_L) - 1) * 100 \quad \dots\dots\dots(2)$$

Cross-Sections and Templates

In order to determine earth excavation and embankment requirements by manual means, a section outline of the proposed highway, commonly referred to as a template section, is placed on the original ground cross-section; the areas in cut and the areas in fill are determined; and the

volumes between the sections are computed. Figure 4.1 shows various conditions that may be encountered when plotting these template sections. “Cut” and “fill” are the terms that are usually used for the areas of the sections, and the terms “excavation” and “embankment” generally refer to volumes.

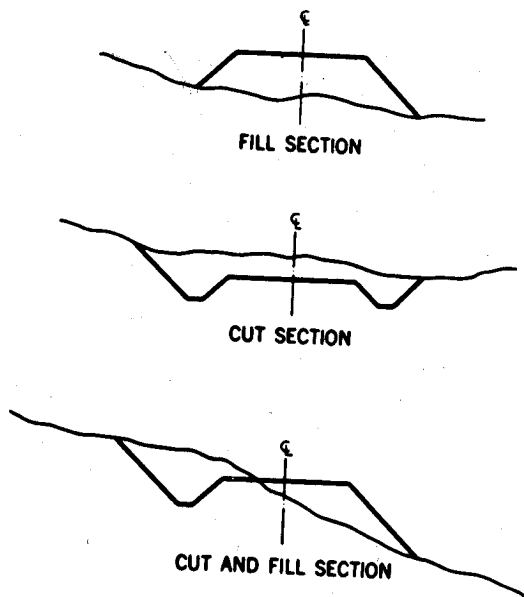

Each cross-section should show the location or station of the original ground section and template section, the elevation of the proposed grade at the station, and the areas of cut and fill for each section. The computed volume of excavation and embankment may also be placed on the cross-section sheet between two successive cross-sections.

Figure 4.1 Original ground line and template sections

Slope Stakes

The final grade line having been established, slope stakes are set at points where the side slopes of the graded road will intersect the ground surface; they mark the limits of the excavation and embankment. The slope stakes are driven at points of zero cut or fill, but the numbers written on them give the vertical distance with reference to the finished grade of the subgrade. On the inner side of the stakes is marked in meters the “cut” or “fill” as the case may be. Thus, “C1.2” indicates that the centerline elevation of the roadbed is to be cut 1.2m below the ground at the slope stake; and “F2.3” indicates that the fill is to be 2.3m above the slope stake.

The stakes are driven with the tops slanting outward and with the sides upon which the cuts or fills are marked facing the roadway. The station number is marked on the outside of the stake.

The usual equipment for setting slopes consists of a level, rod, tape, notebook, stakes, and keel.

If a profile map has been established from previous surveys and the final grade line drawn thereon, the centerline cut or fill may be found from the map by subtracting the elevation of grade from the elevation of ground.

Also, if a cross-section of the ground and finished shape of roadway have been plotted to scale, the position of the slope stakes could be scaled from the map.

Aside from the elevation of grade, the most satisfactory procedure is to determine all distances and elevations in the field. The method must necessarily be a “measure and try” process, but the work can be done rather easily.

General Method of Procedure: Let ABEPD in Figs. 4.2 and 4.3 represent the cross-sectional area of highway in fill or cut, for which we have the following general notation applying to both excavation and embankment:

- $b = AB = AC + CB =$ width of roadbed
- $s =$ "slope ratio" for the banks AD and BE = ratio of horizontal to vertical (plus for cut, minus for fill)
- $d = PC =$ depth of fill or cut at the center
- $x_1 =$ horizontal distance from P to slope stake at D
- $x_2 =$ horizontal distance from P to slope stake at E
- $y =$ vertical distance from P to slope stake
- $h_1 = d + y_1 = FD =$ vertical distance from C to D
- $h_2 = d + y_2 = GE =$ vertical distance from C to E

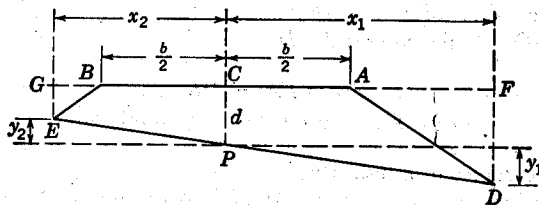

Figure 4.2 Cross section on fill (slope stakes at E and D)

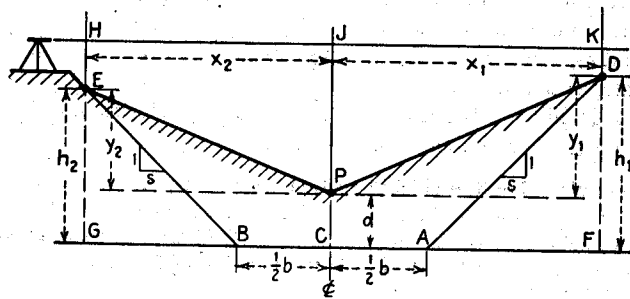

Figure 4.3 Cross section in cut (slope stakes at E and D)

The slope stake at point D on the right is correctly established if

$$x_1 = \frac{1}{2} b + sh_1 = \frac{1}{2} b + sd + sy_1 \dots\dots\dots(3)$$

Likewise, point E on the left is correctly established if

$$x_2 = \frac{1}{2} b + sh_2 = \frac{1}{2} b + sd + sy_2 \dots\dots\dots(4)$$

In the foregoing equations, b , d , and s are known, while x and h (or y) are measured and re-measured in the field until the equations are satisfied (trial-and-error method).

If the ground is level, $y_1 = y_2 = 0$; then $x_1 = x_2 = \frac{1}{2} b + sd$.

In fig. 4.3, it is assumed that rod readings to all points within the cross profile under consideration can be taken from a single position of the level (which of course is not always possible). By means of previous differential leveling from the nearest benchmark, the HI (height of instrument or elevation of line HJK) is established.

If we imagine the bottom of the road to be at grade at point C, the rod reading would be CJ, which is called "grade rod". That is

Grade rod = HI – grade elevation

Negative values of grade rod would occur when the HI is below “grade”.

Since the actual reading at the centerline stake (fig. 4.3) is PJ (not CJ), the depth of cut is $CP = CJ - PJ$; that is,

$$d = \text{grade rod} - \text{ground rod}$$

Negative values of d indicate fill.

Similarly at the slope stake D,

$$FD = FK - DK$$

That is, h_1 (or h_2) = grade rod – ground rod

Negative values of h indicate fill.

The values of x_1 and h_1 (or x_2 and h_2) corresponding to the intersection of two slopes are found easily after two or three field measurements.

Area of Cross-Section

From the data supplied by slope stake or cross-section notes, the area of cross-section may be calculated. If the ground is level or regular, simple geometry may be applied; for irregular ground, two general methods are used; (1) the graphical method and (2) the coordinate method.

- **Area For Level Ground.** For level ground, the area of cross-section in cut (or fill) is merely that of a trapezoid. In figure 4.4:

b = width of base AB

d = center cut (or fill)

s = slope of banks = $MD / AM = NE / BN$

Hence,

$$\text{Area} = d(b + sd) \quad \dots\dots\dots(5)$$

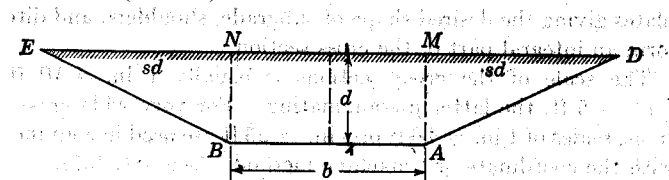

Figure 4.4

- **Area for Three-Level Section.** With three readings taken directly from slope stake notes, one at the center and one at each slope stake, the area of cross section may be obtained. For regular ground, this is an accurate and very satisfactory method. Such a section is known as a three-level section, and the area may be calculated readily from field notes without plotting.

Imagine the area ABED (fig. 4.5) to be divided into four triangles, two having the common base d and altitudes x_1 and x_2 , and two having bases = $\frac{1}{2} b$ and altitudes h_1 and h_2 . Hence the area of section is

$$A = \frac{1}{2} [d(x_1 + x_2) + \frac{1}{2} b(h_1 + h_2)] \quad \dots\dots\dots(6)$$

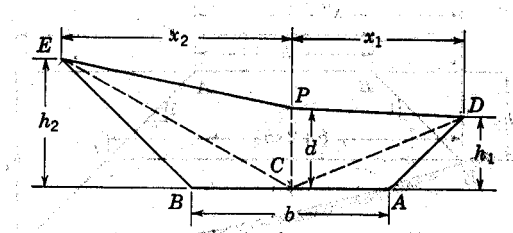

Figure 4.5

If the slope stake notes are not available and the center fill is known, the end area A may be found conveniently from the four field measurements indicated in fig. 4.6. Assuming uniform slope of the original ground underneath the fill,

$$A = \frac{1}{2} (h_1 x'' + h_2 x') \dots\dots\dots(7)$$

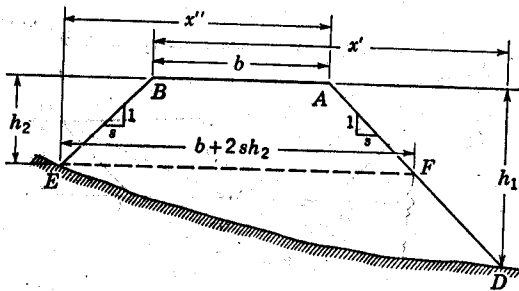

Figure 4.6

➤ **Area By Coordinate Method.** With the coordinates of all the corners of a cross-section known, the end area may be computed by means of the coordinate method.

Let the corners A, B, C, and D of the area ABCD (fig. 4.7) be located by the coordinates (x_1, y_1) , (x_2, y_2) , (x_3, y_3) , and (x_4, y_4) . Then the area is given by the algebraic sum of four trapezoids. Thus,

$$\begin{aligned} \text{Area} &= ABba + BCcb - ADda - DCcd \\ &= \frac{1}{2} [y_1(x_4 - x_2) + y_2(x_1 - x_3) + y_3(x_2 - x_4) + y_4(x_3 - x_1)] \dots\dots\dots(8) \end{aligned}$$

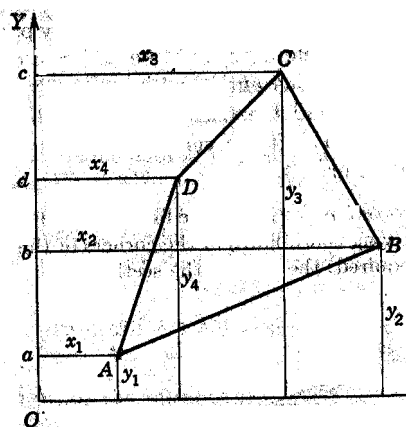

Figure 4.7 Area by coordinate method

From eqn.(8) we may state the following rule for area:

Multiply each ordinate by the algebraic difference between the adjacent abscissas, find the algebraic sum of the products, and then take half of this result.

A simpler rule for area follows if we arrange in counterclockwise order the coordinates (fig. 4.7) in the form of fractions, the initial fraction (beginning at any corner) being repeated to give a closed boundary. Thus, we have

$$\frac{y_1}{x_1} \quad / \quad \frac{y_2}{x_2} \quad / \quad \frac{y_3}{x_3} \quad / \quad \frac{y_4}{x_4} \quad / \quad \frac{y_1}{x_1}$$

Multiply along the marked diagonals and add the products (all positive); multiply along the unmarked diagonals and add the products (all negative). The difference gives the double area.

4.2 Volume of Earthwork

The volume of earthwork may be found by means of either the **average end area** or the **prismoidal** formula. Although the former is less exact than the latter, it is generally accepted as the standard earthwork formula, on account of its simplicity.

- **Average End Area Formula.** The volume of a right prism equals the average area multiplied by the length. Assuming the average area to be the same as the average end area,

$$\text{Volume} = V = \frac{1}{2} (A_1 + A_2)L$$

In which: A_1 and A_2 = area of end sections (m^2)
 L = length of solid (m)

This formula is applied to areas of any shape, but the results are slightly too large. The error is small if the sections do not change rapidly.

- **Prismoidal Formula.** A prismoid is a solid whose ends are parallel and whose sides are plane or wrapped surfaces. Fig. 4.8 represents a typical prismoid.

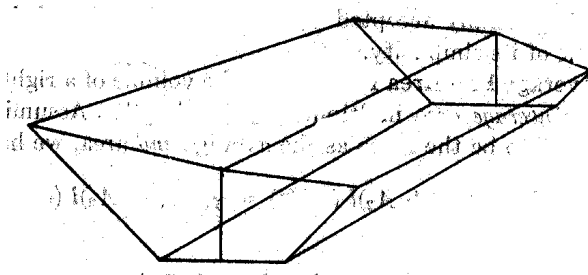

Figure 4.8

The volume of a prismoid is:

$$V = L/6 (A_1 + 4A_m + A_2)$$

In which L is the distance between the two parallel bases A_1 and A_2 and A_m is a section midway between the two end bases and parallel to them. A_m is not an average of A_1 and A_2 , but each of its linear dimensions is an average of the corresponding dimensions of A_1 and A_2 .

4.3 Haul and Overhaul

In grading contracts for roads it is usually stipulated that the contractor shall be paid a certain price per cubic meter for excavating, hauling, and dumping the material, regardless of distance

hailed, provided it does not exceed a specified limit called **free haul**. The free haul distance may be as low as 150m and as high as 900m or more.

If there is an **overhaul** on some of the material, that is, if the distance from excavation to embankment is beyond the free haul limit, then an extra charge may be allowed.

A mass diagram is helpful in determining the amount of overhaul and the most economical distribution of the excavated material.

Limit of Economic Haul

When there are long hauls, it may be more economical to waste and borrow materials rather than pay for the cost of overhauling. Equating the cost of excavation plus overhaul to the cost of excavation from both the roadway and borrow pit, one can estimate the limit of economic haul for making the embankment. Thus, let

c = cost of roadway excavation per cubic meter

b = cost of borrow per cubic meter

h = cost of overhaul, on the bases of 1m^3 per station

x = economical length of overhaul

Cost to excavate and move 1m^3 material from cut to fill

$$= c + hx \quad \dots\dots\dots(a)$$

Cost to excavate from cut, waste, borrow, and place 1m^3 material in fill

$$= b + c \quad \dots\dots\dots(b)$$

Equating equations (a) and (b) and solving for x , we have

$$x = b/h (s + a) \quad \dots\dots\dots(c)$$

adding the free haul distance to equation (c), we get the limit of economical haul.

4.4 Mass Diagram

A mass diagram is a graphical representation of the amount of earthwork and embankment involved in a project and the manner in which the earth is to be moved. Its horizontal or x-axis represents distance and is usually expressed in meters or stations. It is drawn to the same horizontal scale as the profile. The vertical or y-axis represents the cumulative quantity of earthwork in cubic meters. The quantity of excavation on the mass diagram is considered positive, and embankment as negative. Preliminary to drawing the mass curve it is convenient to tabulate the cumulative volumes of cuts and fills at each station.

The mass diagram allows a highway engineer to determine direction of haul and the quantity of earth taken from or hauled to any location. It shows “balance points”, the stations between which the volume of excavation (after adjustment for “shrinkage” or “swell”) and embankment are equal.

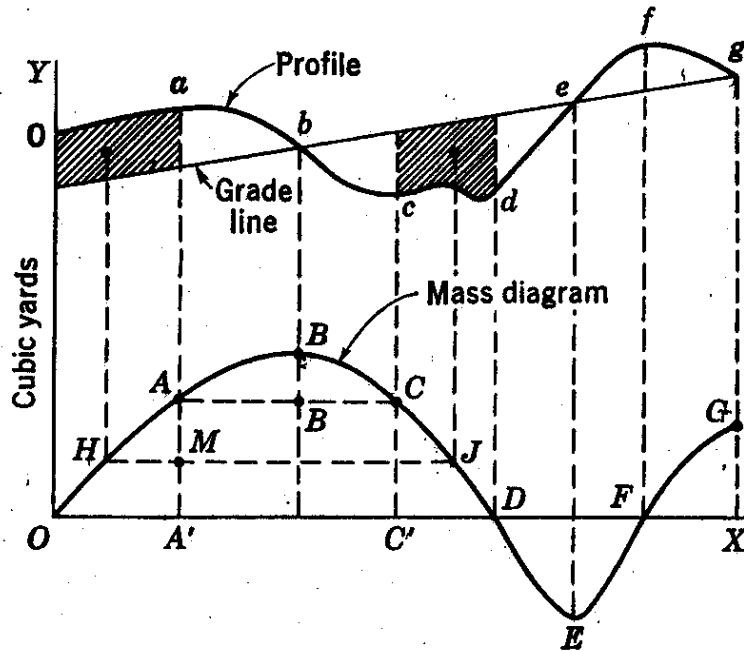

Figure 4.9 Profile and mass diagram. AC = free-haul distance; $HJ - AC$ = overhaul distance; BB = free-haul volume; $A'A = C'C$ = overhaul volume; OD = length of balance.

A study of the mass diagram (or curve) shown in figure 4.9 will verify the following statements:

- The ordinate at any point on the mass curve represents the cumulative volume to that point on the profile.
- Within the limits of a single cut, the curve rises from left to right; within the limits of a single fill, it falls from left to right.
- Sections where the volume changes from cut to fill correspond to a maximum; sections where the volume changes from fill to cut correspond to a minimum. Evidently the maximum and minimum points on the diagram occur at, or near, grade points on the profile.
- Any horizontal line, as AC , cutting off a loop of the mass curve, intersects the curve at two points between which the **cut is equal to the fill** (adjusted for shrinkage). Such a line is called a **balance line**.
- The loops convex upward indicate that the haul from cut to fill is to be in one direction (to the right in this case); loops concave upward indicate a reverse direction of haul.
- The final point on a mass diagram for a given project gives the overall net amount of earthwork for the entire project. This amount, if positive, would indicate a surplus of excavation material and a need to waste that quantity of material. If the final point on the mass diagram is a negative amount, it indicates a net shortage of earthwork for the project and a need to borrow that quantity of earthwork material.

Determination of Overhaul from the Mass Diagram: One of the important uses of the mass diagram, aside from balancing cuts and fills and indicating the most advantageous distribution of the same, is to establish definitely the overhaul distance and the portion of the total volume which is to be regarded as hauled beyond the specified free-haul limit.

Referring to figure 4.9, proceed as follows:

- i. Assuming the free-haul distance to be 150m, find by trial a horizontal line intersecting the curve at points A and C, such that $AC = 150\text{m}$. Then the material above line AC will be hauled at no extra cost. The amount of this material is given by the ordinate from line AC to point B and is a measure of the volume in cut from a to b, which makes the fill from b to c.
- ii. Consider now the volume above the balance line OD. A study of the mass curve and the corresponding profile shows that the cut from o to b will make the fill from b to d. But since part of this solidity, the part above the balance line AC, is included in the free-haul limit, the other part between lines OD and AC – which is measured by the ordinate $A'A$ – is subject to overhaul unless wastage and borrow take place. That is, some or all of the volume from o to a may be “overhauled” to make the fill from c to d.

The average length of haul of the solidity from o to a to make the fill from c to d is the distance between the centers of gravity of cut o to a and fill c to d. The gravity lines are found as follows: Bisect AA' at M and draw a horizontal line intersecting the mass curve at H and J. These points H and J are assumed to be vertically below the desired centers of gravity. Therefore the average haul is given by the length of line HJ, and the overhaul is this distance HJ less the free haul distance AC. The overhaul distance (in stations) multiplied by the net volume gives the station-volumes of overhaul.

It should be note that the foregoing graphical method of determining the center of gravity of the masses in cut and fill is inaccurate when there is abruptness in the mass curve. In such cases, a more accurate method is to divide the volume in parts and take moments about a vertical line of reference just as is done in finding the center of gravity of a system of forces.

The mass diagram may be used to indicate the most economical procedure for disposing of excavated material, what part of it should be moved forward or backward, and whether borrowing and wasting are advisable. Thus if the balance line OD is continued horizontally to point X, it will be seen that the cuts and fills from o to f are balanced, but the solidity represented by the ordinate at G is excess cut (from f to g) which may be carried forward, backward, or wasted. If the project ends at point g or if there are no fills immediately ahead, then this excavated material should be carried backward to help make the fill from b to c (it being downhill and within the free-haul limit), while an equivalent amount of volume from the cut o to a would be wasted, thus reducing the station-volume of overhaul.

CHAPTER FIVE

5 HIGHWAY DRAINAGE

5.1 Introduction

Provision of sufficient drainage is an important factor in the location and geometric design of highways. Drainage facilities on any highway or street should adequately provide for the flow of water away from the surface of the pavement to properly designed channels. Inadequate drainage will eventually result in serious damage to the highway structure. In addition, traffic may be slowed by accumulated water on the pavement, and accidents may occur as a result of hydroplaning and loss of visibility from splash and spray. The highway engineer is concerned primarily with two sources of water. The first, surface water is that which occurs as rain or snow. Some of this is absorbed into the soil, and the remainder remains on the surface of the ground and should be removed from the highway pavement. Drainage for this source of water is referred to as surface drainage. The second source, ground water, is that which flows in underground streams. This may become important in highway cuts or at locations where a high water table exists near the pavement structure. Drainage for this source is referred to as subsurface drainage. In this chapter, we present the fundamental design principles for surface and subsurface drainage facilities.

5.2 Surface drainage

Surface drainage encompasses all means by which surface water is removed from the pavement and right of way of the highway or street. A properly designed highway surface drainage system should effectively intercept all surface and watershed runoff and direct this water into adequately designed channels and gutters for eventual discharge into the natural waterways. Water seeping through cracks in the highway riding surface and shoulder areas into underlying layers of the pavement may result in serious damage to the highway pavement. The major source of water for this type of intrusion is surface runoff. An adequately designed surface drainage system will therefore minimize this type of damage. The surface drainage system for rural highways should include sufficient transverse and longitudinal slopes on both the pavement and shoulder to ensure positive runoff and longitudinal channels (ditches), culverts, and bridges to provide for the discharge of the surface water to the natural waterways. Storm drains and inlets are also provided on the median of divided highways in rural areas. In urban areas, the surface drainage system also includes enough longitudinal and transverse slopes, but the longitudinal drains are usually underground pipe drains designed to carry both surface runoff and ground water. Curbs and gutters also may be used in urban and rural areas to control street runoff, although they are more frequently used in urban areas.

Transverse Slopes

The main objective for providing slopes in the transverse direction is to facilitate the removal of surface water from the pavement surface in the shortest possible time. This is achieved by crowning the surface at the center of the pavement, thereby providing cross slopes on either side of the centerline or providing a slope in one direction across the pavement width. Shoulders, however, are usually sloped to drain away from the pavement, except on highways with raised narrow medians. The need for high cross slopes to facilitate drainage is somewhat in conflict

with the need for relatively flat cross slopes for driver comfort. Selection of a suitable cross slope is therefore usually a compromise between the two requirements. It has been determined that cross slopes of 2 percent or less do not significantly affect driver comfort, particularly with respect to the driver's effort in steering

Longitudinal Slopes

A minimum gradient in the longitudinal direction of the highway is required to obtain adequate slope in the longitudinal channels, particularly at cut sections. Slopes in longitudinal channels should generally not be less than 0.2 percent for highways in very flat terrain. Although zero percent grades may be used on uncurbed pavements with adequate cross slopes, a minimum of 0.5 percent is recommended for curbed pavements. This may be reduced to 0.3 percent on suitably crowned high-type pavements constructed on firm ground.

Longitudinal Channels

Longitudinal channels (ditches) are constructed along the sides of the highway to collect the surface water that runs off from the pavement surface, subsurface drains, and other areas of the highway right of way. When the highway pavement is located at a lower level than the adjacent ground, such as in cuts, water is prevented from flowing onto the pavement by constructing a longitudinal drain (intercepting drain) at the top of the cut to intercept the water. The water collected by the longitudinal ditches is then transported to a drainage channel and next to a natural waterway or retention pond.

Curbs and Gutters

Curbs and gutters can be used to control drainage in addition to other functions, which include preventing the encroachment of vehicles on adjacent areas and delineating pavement edges. Curbs and gutters are used more frequently in urban areas, particularly in residential areas, where they are used in conjunction with storm sewer systems to control street runoff. When it is necessary to provide relatively long continuous sections of curbs in urban areas, the inlets to the storm sewers must be adequately designed for both size and spacing so that the impounding of large amounts of water on the pavement surface is prevented.

5.3 Determination of Runoffs

The amount of runoff for any combination of intensity and duration depends on the type of surface. For example, runoff will be much higher on rocky or bare impervious slopes, roofs, and pavements than on plowed land or heavy forest. The highway engineer is therefore interested in determining the proportion of rainfall that remains as runoff. This determination is not easy, since the runoff rate for any given area during a single rainfall is not usually constant. Several methods for estimating runoff are available. Two commonly used methods are presented.

Rational Method

The rational method is based on the premise that the rate of runoff for any storm depends on the average storm intensity, the size of the drainage area, and the type of drainage area surface. Note that for any given storm, the rainfall intensity is not usually constant over a large area, nor during the entire storm's duration. The rational formula therefore uses the theory that, for a rainfall of average intensity (I) falling over an impervious area of size (A), the maximum rate of runoff at the outlet to the drainage area (Q) occurs when the whole drainage area is contributing to the

runoff and this runoff rate is constant. This requires that the storm duration be at least equal to the time of concentration, which is the time required for the runoff to flow from the farthest point of the drainage area to the outlet. This condition is not always satisfied in practice, particularly in large drainage areas. It is therefore customary for the rational formula to be used for relatively small drainage areas not greater than 200 acres. The rational formula is given as:

$$Q = 0.00278 \cdot CIA$$

$$C = \frac{C_1 A_1 + C_2 A_2 + \dots}{A_1 + A_2 + \dots}$$

- Q = runoff (m^3/sec)
- C =coefficient, representing ratio of runoff to rainfall
- I = intensity of rainfall (mm/hr) for a duration equal to the time of concentration
- A = catchment area tributary to the design location, ha

Rainfall Intensity

Runoff is obtained by considering expected sever storm.

- Return period of 5, 10, 20, 25, 50, and 100 years
- Quantity of runoff depends on intensity and duration.
- Duration= Time of Concentration
 - The time required for water from the remotest place to reach a specific point on the drainage system.
 - $=T_1+T_2$
- T_1 = over land flow time
- T_2 = time of flow in the longitudinal drain

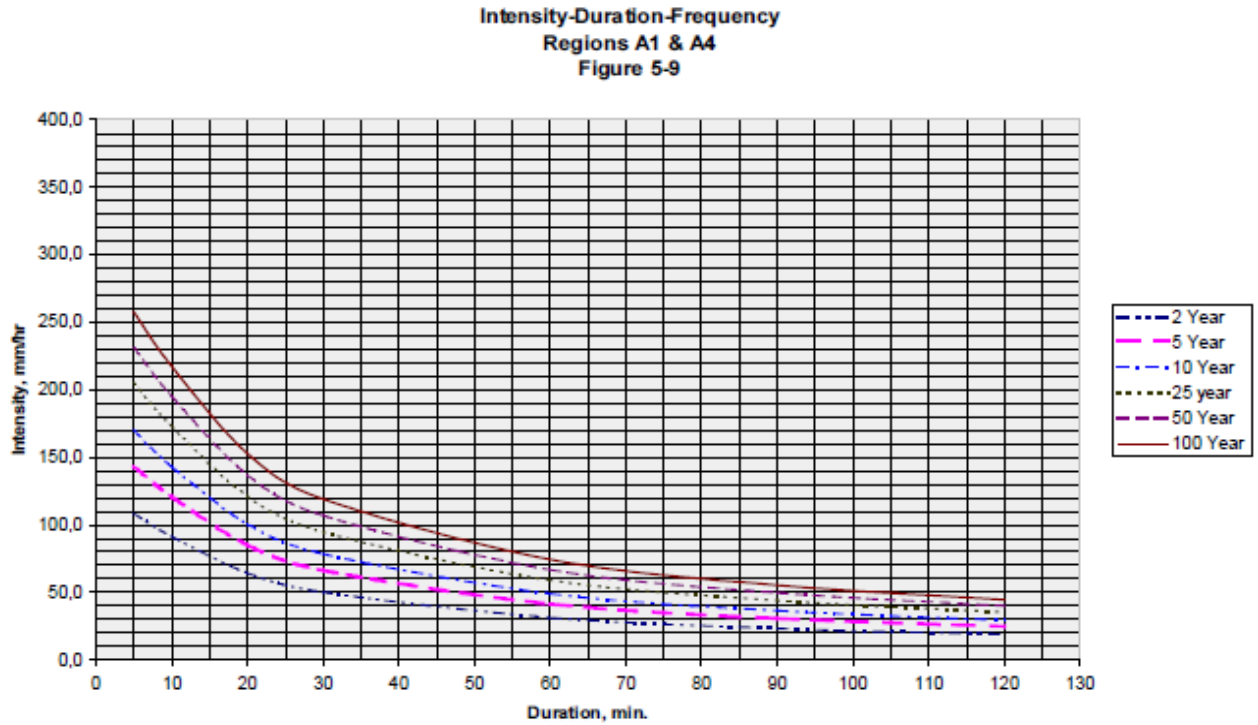

Figure 5.1 Intensity duration frequency diagram for region A1 and A4

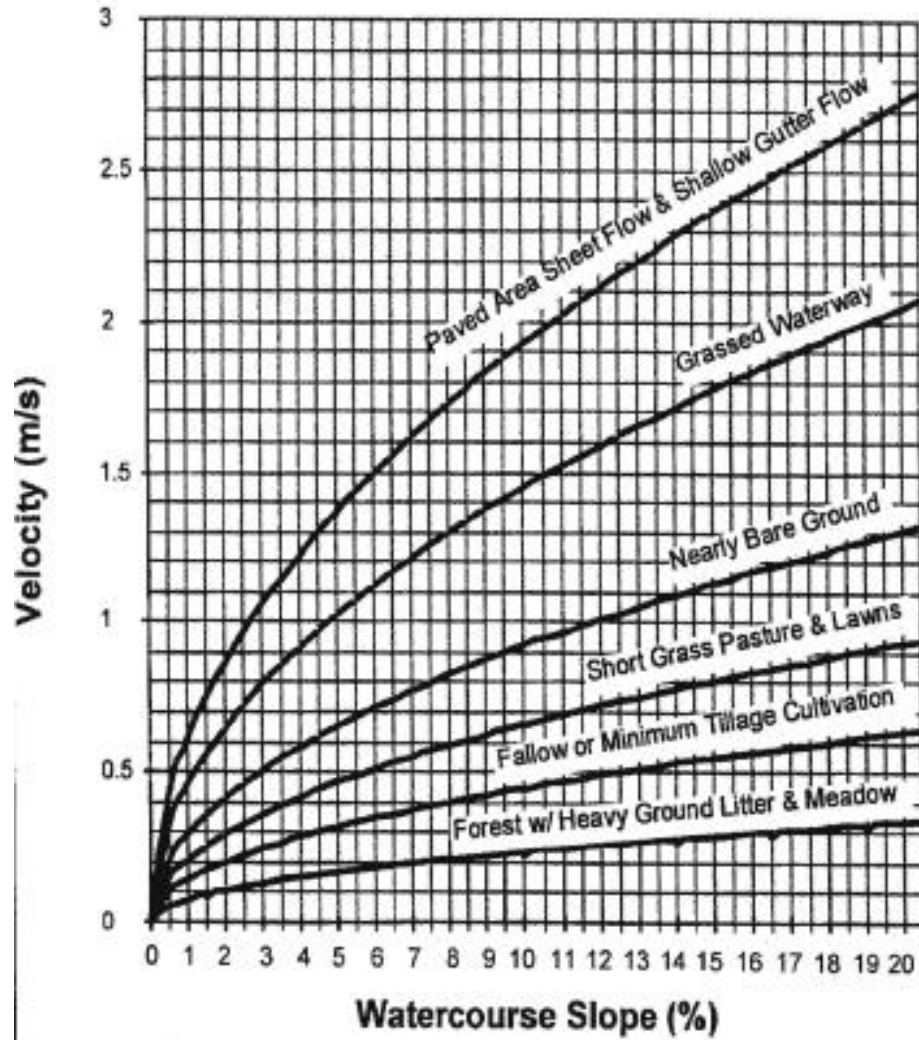

Figure 5.2 Watercourse slope vs Velocity diagram

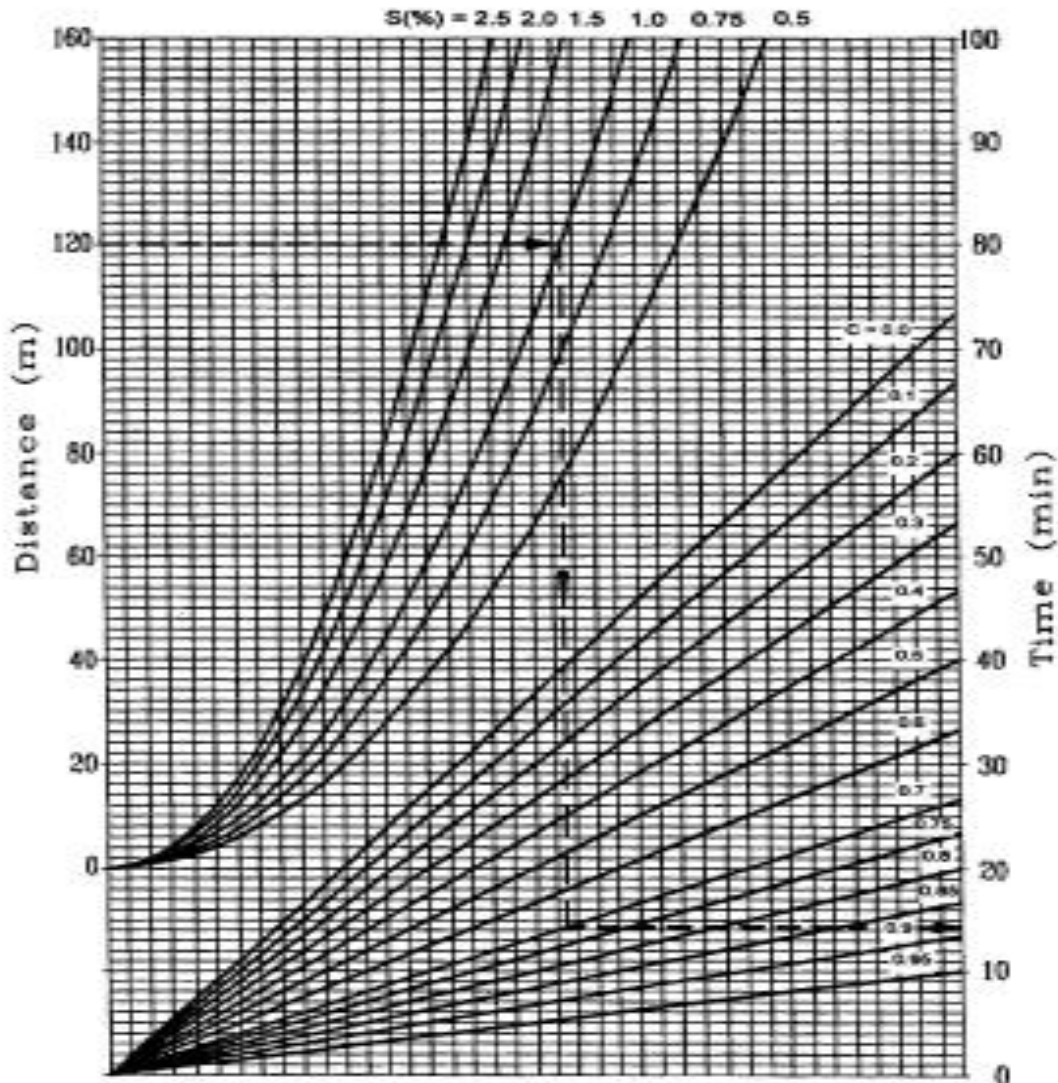

Figure 5.3 Overland time of flow

5.4 Design of Open Channels

An important design consideration is that the flow velocity in the channel should not be so low as to cause deposits of transported material nor so high as to cause erosion of the channel. The velocity that will satisfy this condition usually depends on the shape and size of the channel, the type of lining in the channel, the quantity of water being transported, and the type of material suspended in the water. The most appropriate channel gradient range to produce the required velocity is between 1 percent and 5 percent. For most types of linings, sedimentation is usually a problem when slopes are less than 1 percent, and excessive erosion of the lining will occur when slopes are higher than 5 percent.

Attention also should be paid to the point at which the channel discharges into the natural waterway. For example, if the drainage channel at the point of discharge is at a much higher elevation than the natural waterway, then the water should be discharged through a spillway or chute to prevent erosion.

Design Principles

The hydraulic design of a drainage ditch for a given storm entails the determination of the minimum cross-sectional area of the ditch that will accommodate the flow due to that storm and prevent water from overflowing the sides of the ditch. The most commonly used formula for this purpose is Manning's formula, which assumes uniform steady flow in the channel and gives the mean velocity in the channel as

$$V = \frac{1}{n} R^{2/3} S^{1/2} \quad Q = V \cdot A$$

where:

- V= mean velocity (m/sec)
- R= hydraulic radius (m)= Area/wetted perimeter
- S=slope of the channel (m/m)
- n=Manning's roughness coefficient

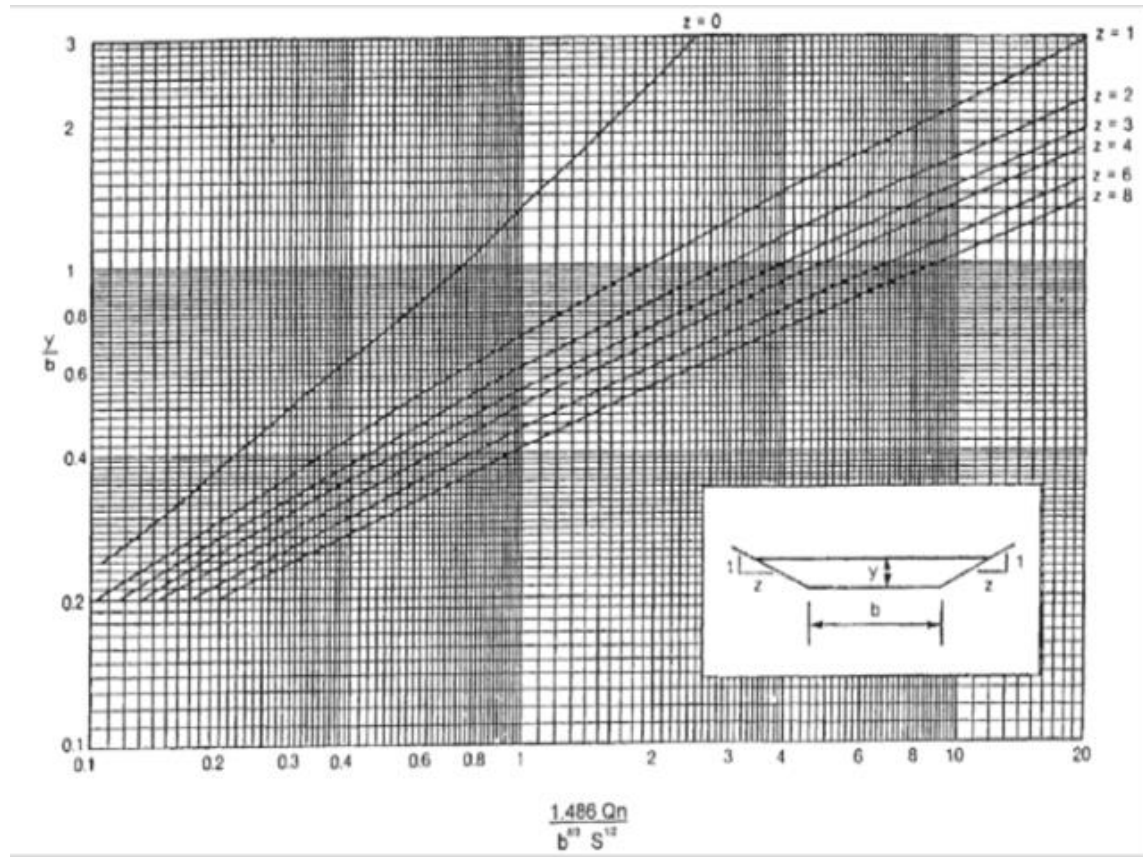

Figure 5.4 Trapezoidal channel capacity charts

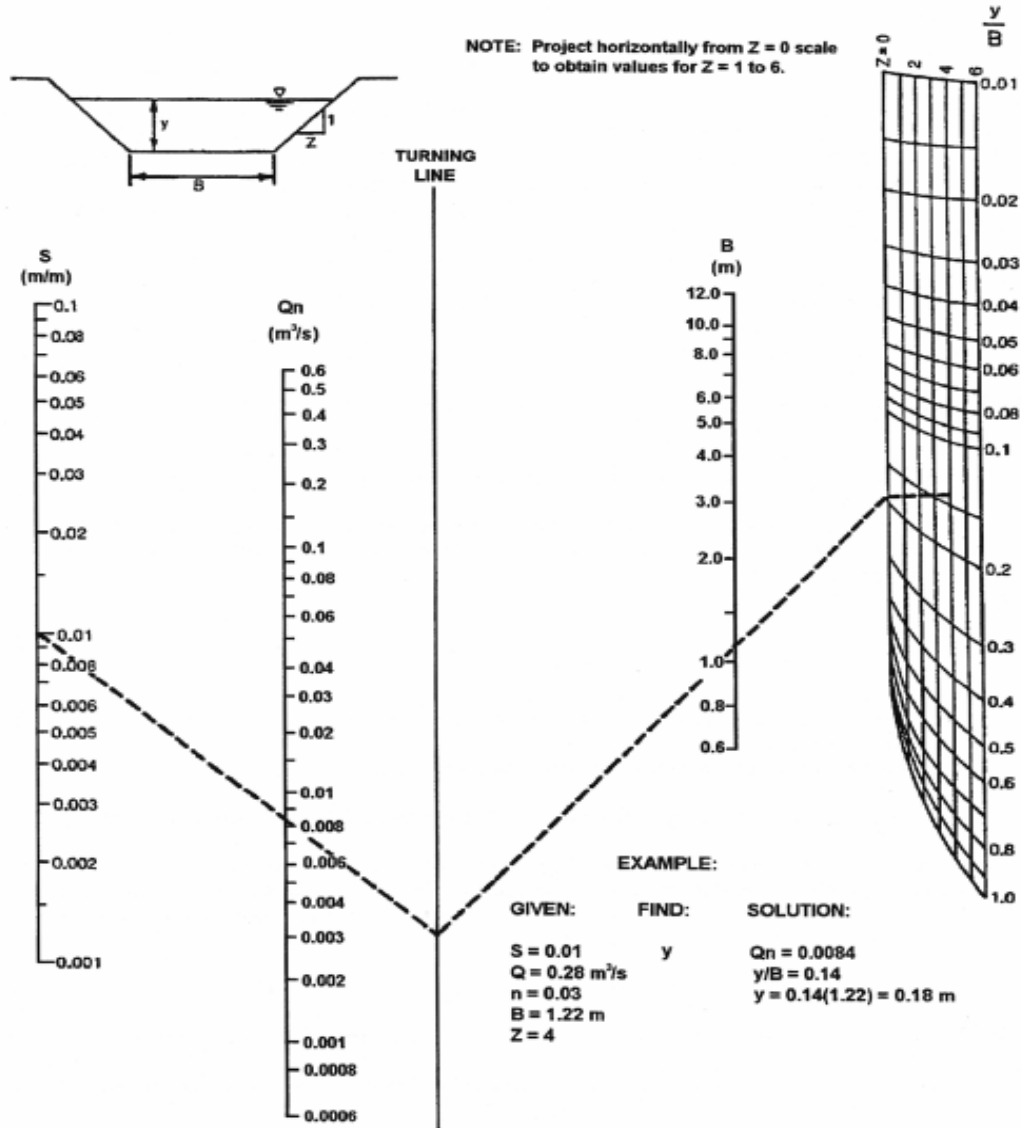

Figure 5.5 Design chart for open channel ditch

5.5 Subsurface Drainage

Subsurface drainage systems are provided within the pavement structure to drain water in one or more of the following forms: Water that has permeated through cracks and joints in the pavement to the underlying strata. Water that has moved upward through the underlying soil strata as a result of capillary action.

Water that exists in the natural ground below the water table, usually referred to as ground water. The subsurface drainage system must be an integral part of the total drainage system, since the subsurface drains must operate in consonance with the surface drainage system to obtain an efficient overall drainage system.

The design of subsurface drainage should be carried out as an integral part of the complete design of the highway, since inadequate subsurface drainage also may have detrimental effects on the stability of slopes and pavement performance. However, certain design elements of the highway such as geometry and material properties are required for the design of the subdrainage system. Thus, the procedure usually adopted for subdrainage design is first to determine the geometric and structural requirements of the highway based on standard design practice, and then to subject these to a subsurface drainage analysis to determine the subdrainage requirements. In some cases, the subdrainage requirements determined from this analysis will require some changes in the original design.

It is extremely difficult, if not impossible; to develop standard solutions for solving subdrainage problems because of the many different situations that engineer come across in practice. Therefore, basic methods of analysis are given that can be used as tools to identify solutions for subdrainage problems. The experience gained from field and laboratory observations for a particular location, coupled with good engineering judgment, should always be used in conjunction with the design tools provided. Before presenting the design tools, discussions of the effects on the highway of an inadequate subdrainage system and the different subdrainage systems are first presented.

Effect of Inadequate Subdrainage

Inadequate subdrainage on a highway will result in the accumulation of uncontrolled subsurface water within the pavement structure and/or right of way, which can result in poor performance of the highway or outright failure of sections of the highway. The effects of inadequate subdrainage fall into two classes: poor pavement performance and instability of slopes.

Pavement Performance

If the pavement structure and subgrade are saturated with underground water, the pavement's ability to resist traffic load is considerably reduced, resulting in one or more of several problems, which can lead to premature destruction of the pavement if remedial actions are not taken in time. In Portland cement concrete pavement, for example, inadequate subdrainage can result in excessive repeated deflections of the pavement, which will eventually lead to cracking. When asphaltic concrete pavements are subjected to excessive uncontrolled subsurface water due to inadequate subdrainage, very high pore pressures are developed within the untreated base and subbase layers, resulting in a reduction of the pavement strength and thereby its ability to resist traffic load. Another common effect of poor pavement performance due to inadequate subdrainage is frost action. As described later, this phenomenon requires that the base and/or subbase material be a frost-susceptible soil and that an adequate amount of subsurface water is present in the pavement structure. Under these conditions, during the active freezing period, subsurface water will move upward by capillary action toward the freezing zone and subsequently freeze to form lenses of ice. Continuous growth of the ice lenses due to the capillary action of the subsurface water can result in considerable heaving of the overlying pavement. This eventually leads to serious pavement damage, particularly if differential frost heaving occurs. Frost action also has a detrimental effect on pavement performance during the spring thaw period. During this period, the ice lenses formed during the active freeze period gradually thaw from the top down, resulting in the saturation of the subgrade soil, which results in a substantial reduction of pavement strength.

Slope Stability

The presence of subsurface water in an embankment or cut can cause an increase of the stress to be resisted and a reduction of the shear strength of the soil forming the embankment or cut. This can lead to a condition where the stress to be resisted is greater than the strength of the soil, resulting in sections of the slope crumbling down or a complete failure of the slope.

Highway Subdrainage Systems

Subsurface drainage systems are usually classified into five general categories:

- Longitudinal drains
- Transverse drains
- Horizontal drains
- Drainage blankets
- Well systems

Longitudinal Drains

Subsurface longitudinal drains usually consist of pipes laid in trenches within the pavement structure and parallel to the center line of the highway. These drains can be used to lower the water table below the pavement structure, as shown in Figure 16.29, or to remove any water that is seeping into the pavement structure, as shown in Figure 16.30. In some cases, when the water table is very high and the highway is very wide, it may be necessary to use more than two rows of longitudinal drains to achieve the required reduction of the water table below the pavement structure.

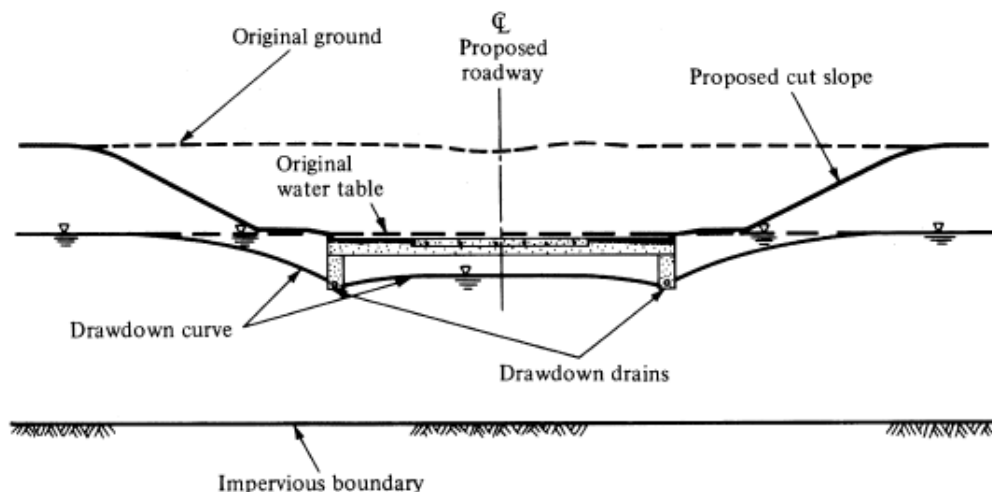

Figure 5.6 Longitudinal drains

Transverse Drains

Transverse drains are placed below the pavement, usually in a direction perpendicular to the center line, although they may be skewed to form a herringbone configuration. An example of the use of transverse drains is shown in Figure 16.32 where they are used to drain ground water that has infiltrated through the joints of the pavement. One disadvantage of transverse drains is that they can cause unevenness of the pavement when used in areas susceptible to frost action,

where general frost heaving occurs. The unevenness is due to the general heaving of the whole pavement, except at the transverse drains.

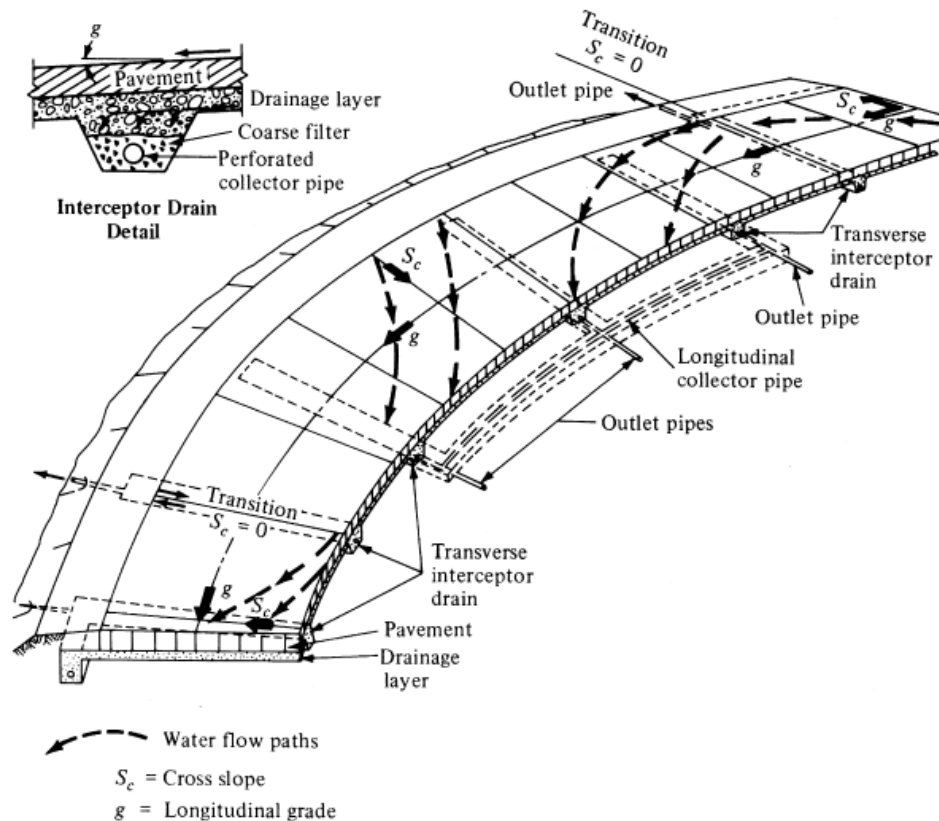

Figure 5.7 Transverse drains on superelevated curves

Horizontal Drains

Horizontal drains are used to relieve pore pressures at slopes of cuts and embankments on the highway. They usually consist of small diameter, perforated pipes inserted into the slopes of the cut or fill. The subsurface water is collected by the pipes and is then discharged at the face of the slope through paved spillways to longitudinal ditches.

Drainage Blankets

A drainage blanket is a layer of material that has a very high coefficient of permeability, usually greater than 30 ft /day, and is laid beneath or within the pavement structure such that its width and length in the flow direction are much greater than its thickness. The coefficient of permeability is the constant of proportionality of the relationship between the flow velocity and the hydraulic gradient between two points in the material. Drainage blankets can be used to facilitate the flow of subsurface water away from the pavement, as well as to facilitate the flow of ground water that has seeped through cracks into the pavement structure or subsurface water from artesian sources. A drainage blanket also can be used in conjunction with longitudinal drains to improve the stability of cut slopes by controlling the flow of water on the slopes, thereby preventing the formation of a slip surface. However, drainage blankets must be properly designed to be effective.

Well Systems

A well system consists of a series of vertical wells, drilled into the ground, into which ground water flows, thereby reducing the water table and releasing the pore pressure. When used as a temporary measure for construction, the water collected in the wells is continuously pumped out, or else it may be left to overflow. A more common construction, however, includes a drainage layer either at the top or bottom of the wells to facilitate the flow of water collected.

CHAPTER SIX

6 INTERSECTION AND INTERCHANGES

6.1 Types of Intersection

Intersections are inevitable parts of any street system. A road or street intersection can be defined as the general area where two or more roads join or cross, including the roadway and roadside facilities for traffic movement within it (AASHTO, 2001). An intersection needs to be designed considering the efficiency, safety, speed, cost of operation, and capacity that it can offer to users.

In general, there are three types of intersections:

- (1) At-grade intersection
- (2) Grade separated without ramps, and
- (3) Interchanges

The common intersection is *at-grade* intersection where two or more highways join. The approaches are referred to as *intersection legs*. When it becomes necessary to accommodate high volume of traffic through intersections, intersections that are separated by grade are used, and these are generally referred to as *interchanges*. When two highways or streets cross each other at a different grade, with no connections, the arrangement is referred to as a *grade separation*.

Details of the geometric design of at-grade intersections and interchanges are given in *A policy on Geometric Design of Highways and Streets* published by the American Association of State Highway and Transportation Officials (AASHTO, 2001).

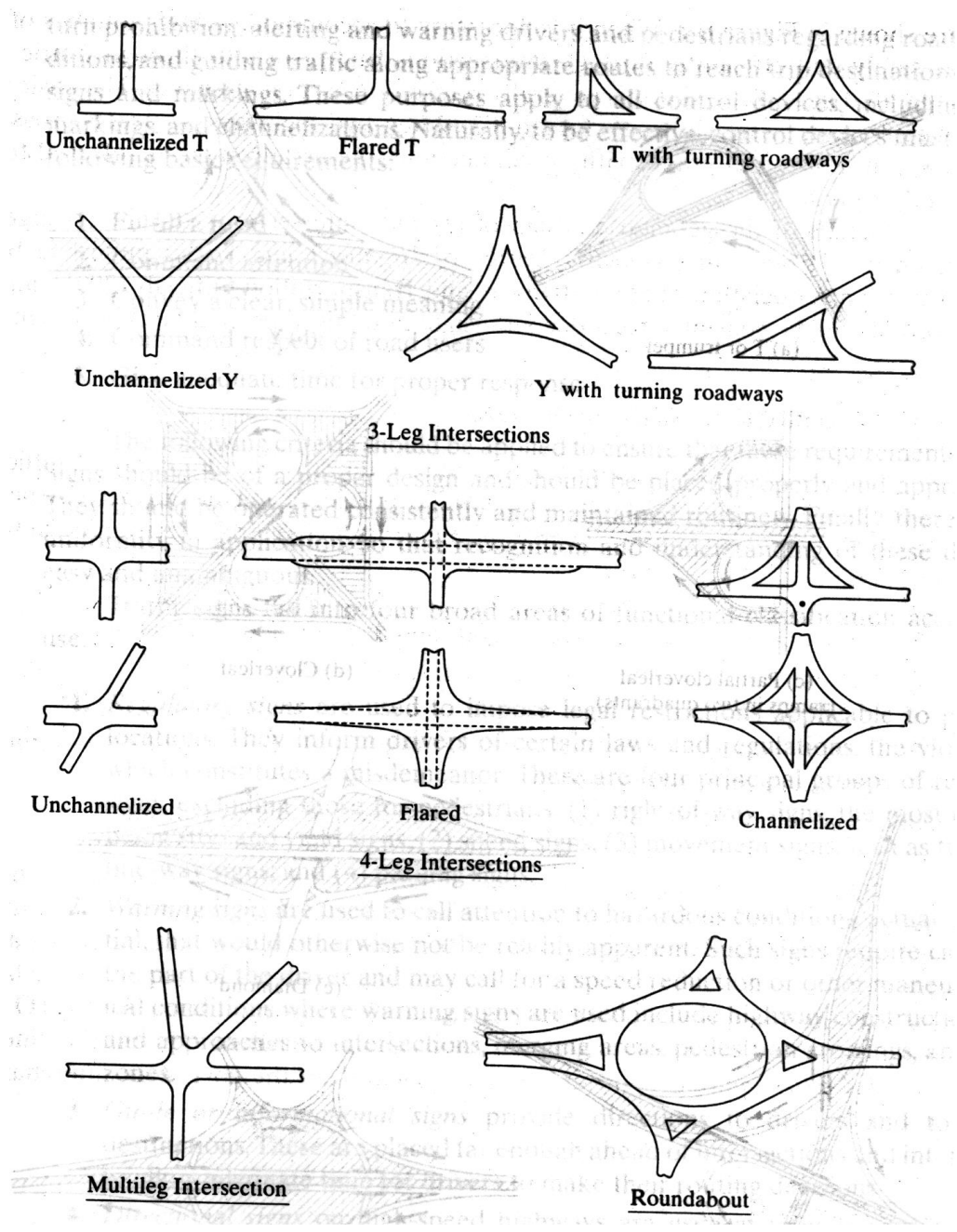

Figure 6-1 Examples of At-Grade Intersections

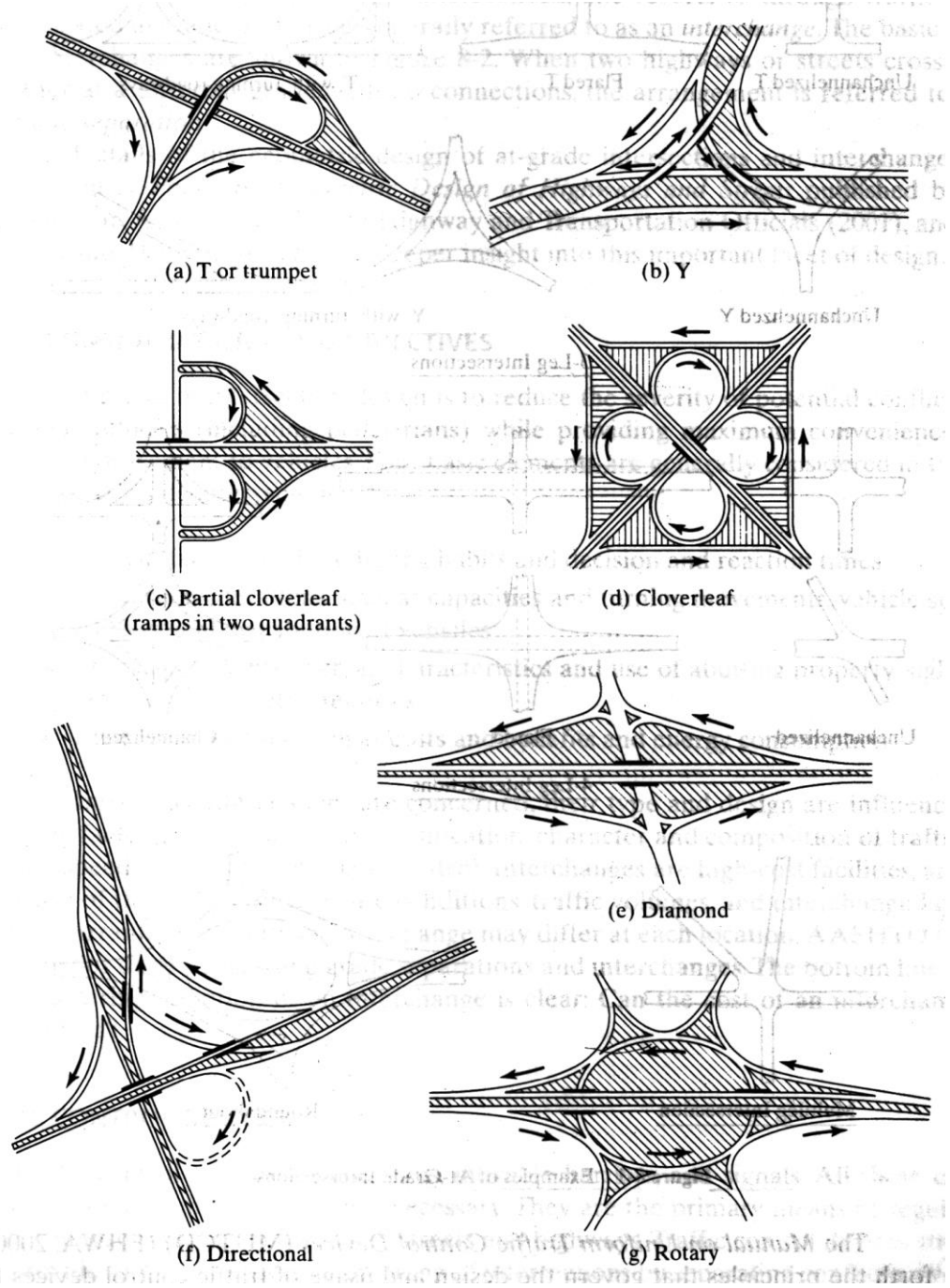

Figure 6-2 Types of Interchanges

6.2 Design Consideration and Objectives

The objective of intersection design is to *reduce the severity of potential conflicts* between vehicles (including pedestrians) while providing maximum convenience and ease of movement to vehicles. Four basic elements are generally considered in the design of at-grade intersections.

- a. Human factor, such as driving habits and decision and reaction times
- b. Traffic considerations, such as capacities and turning movements, vehicle speeds, and size and distribution of vehicles
- c. Physical elements, such as characteristics and use of abutting property, sight distance, and geometric features
- d. Economic factors, such as costs and benefits and energy consumption

The design and type of interchanges is influenced by many factors, such as highway classification, character and composition of traffic, design speed, and degree of access control. Interchanges are high-cost facilities, and because of the wide variety of site conditions, traffic volumes, and interchange layouts, the warrants that justify an interchange may differ at each location. AASHTO (2001) provides details regarding grade separations and interchanges. The main important thing when considering interchanges is clearly the economic justification.

6.3 Conflict area at Intersection

Fig. 5.3 shows vehicle streams and the merging, diverging, and crossing maneuvers for a simple four-leg intersection, and for a more complicated staggered intersection. Such diagrams are useful because the number and type of conflicts may indicate the accident potential of an intersection. In the case of a regular two-lane, four-leg intersection there are 16 potential crossings conflict points, 8 merging and 8 diverging conflict points. The staggered T-intersection shown in the figure serves about the same function as the four-leg intersection, and consists of only six potential crossing conflict points, three diverging and three merging conflict points.

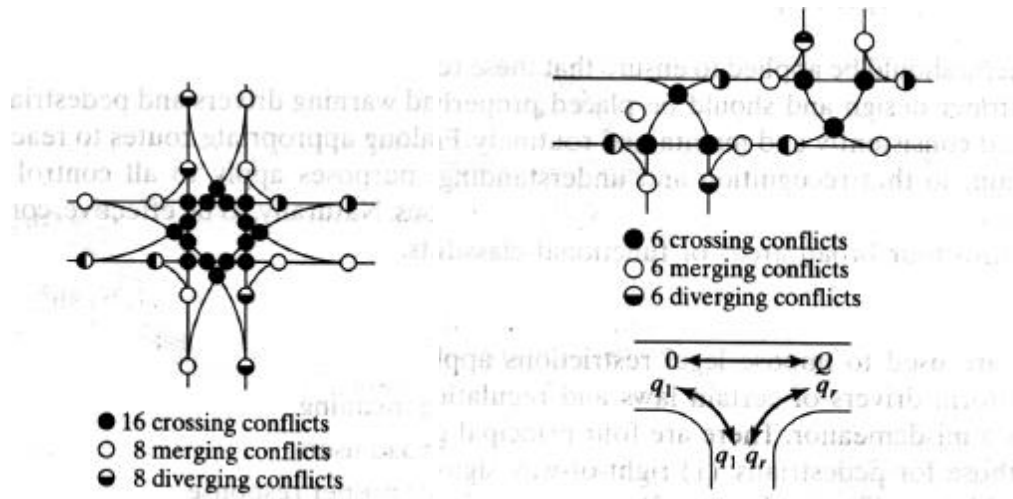

Figure 6-3 Vehicle Streams and the Merging, Diverging, and Crossing Maneuvers

6.4 Type of Intersection Control

There are at least six principal ways of controlling traffic at intersections, depending on the type of intersection and the volume of traffic in each of the vehicle streams. In an ascending order of control exercised at the intersection, these include no control, channelization, yield or stop signs, roundabouts and traffic signals. The FHWA, 2000 provides guidelines for adopting any particular type of intersection control, in the form of warrants.

6.4.1 Stop signs

Stop signs are warranted at intersections under the following conditions:

- I. Intersection of less important road with a main road, where application of the normal right-of-way rule is unduly hazardous
- II. Intersection of a county road, city street, or township road with a state highway
- III. Street entering a through highway or street
- IV. Unsignalized intersection in a signalized area
- V. Unsignalized intersection where a combination of high speed, restricted view and serious accident record indicates a need for control by the stop sign

Multiway (fourway or all-way) stops can be used as a safety measure at some locations where the volume on the intersecting roads is approximately equal and following conditions exist:

- I. An accident problem, as indicated by five or more reported accidents in a 12 months period, which may be corrected by a multiway stop installation
- II. (a) The total vehicular volume entering the intersection from all approaches averages at least 500 vehicles per hour for any 8 hours of an average day, and (b) the combined

- vehicular and pedestrian volume from the minor street or highway averages at least 200 units per hour for the same 8 hours, with an average delay to minor street vehicular traffic of at least 30 seconds per vehicle during the maximum hour, but (c) when the 85th percentile approach speed of the major street traffic exceeds 40mph, the minimum vehicular volume warrant is 70% of the foregoing requirements.
- III. Where traffic signals are warranted, the multiway stop control can be used as an interim measure while arrangements are being made for installation of the signal.

6.4.2 Yield Signs

Yield signs are established as follows:

- i. On a minor road at the entrance to an intersection when it is necessary to assign the right-of-way to the major road, but where a stop is not necessary at all times, and where the safe approach speed on the minor road exceeds 10mph.
- ii. On the entrance ramp to an expressway, where an adequate acceleration lane is provided
- iii. Where there is a separate or channelized right-turn lane without an adequate acceleration lane
- iv. At any intersection where a problem can be possibly corrected by a yield sign installation
- v. Within an intersection with a divided highway, where a stop sign is present at the entrance to the first roadway, and further control is necessary at the entrance to the second roadway. Median width between roadways must exceed 30 ft.

6.4.3 Intersection Channelization

Channelization is the separation or regulation of conflicting traffic movements into definite paths of travel by traffic islands or pavement markings to facilitate the safe and orderly movements of both vehicles and pedestrians. Proper channelization increases capacity, improves safety, provides maximum convenience, and increases driver confidence. Channelization is frequently used along with stop or yield signs or at signalized intersections.

Some basic principles to help design channelized intersection are as follows:

- i. Motorists should be provided with channel lines that are easy to follow.
- ii. Sudden and sharp reverse curves should be avoided.

- iii. Areas of vehicle conflict should be reduced as much as possible.
- iv. Traffic streams that cross without merging and weaving should intersect at or near right angles.
- v. Islands should be carefully selected and be as few as possible.
- vi. Over channelization should be avoided, as it has proved to be counterproductive.

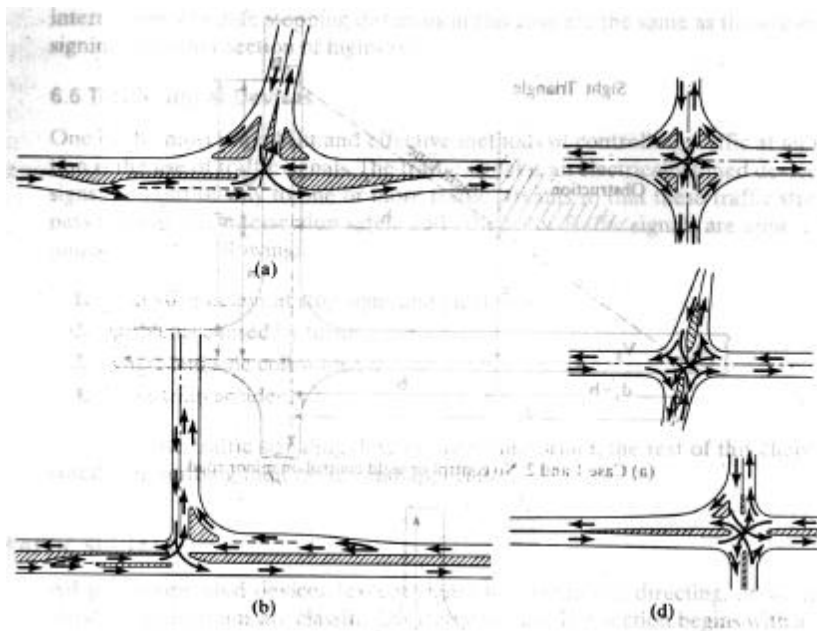

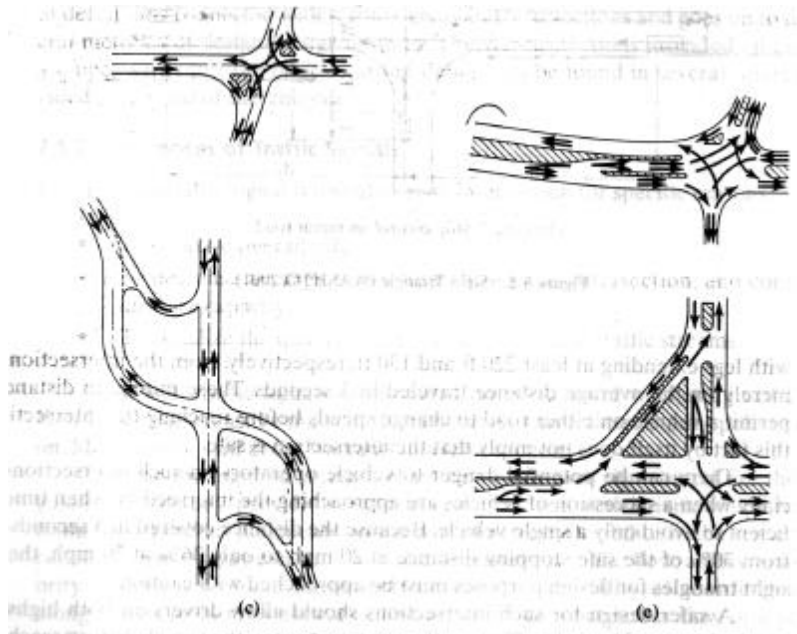

Figure 6-4 Typical Examples of Channelized Intersections (AASHTO, 2001)

Rotaries and Roundabouts

Rotaries and roundabout are channelized intersections comprising a central circle surrounded by a one-way roadway. The basic difference between rotaries and roundabouts is that rotaries are generally signalized, whereas roundabouts are not. Naturally, in the case of roundabouts, entering traffic yields to traffic within.

Roundabouts generally have good safety records and traffic does not have to stop when traffic volumes are low. A well-designed roundabout should deflect the path of vehicles passing through an intersection by the use of a sufficiently large central island, properly designed approach islands, and staggering the alignment of entries and exits.

6.4.4 Uncontrolled Intersections

Where an intersection has no control device, the operator of a vehicle approaching an intersection must be able to perceive a hazard in sufficient time to alter the vehicle's speed, before reaching the intersection. The time needed to start decelerating is the driver's perception and reaction time and may be assumed to be 2.0 sec. In addition, the driver needs to begin braking some distance from the intersection. This distance from the intersection, where a driver can first see a vehicle approaching on the intersecting road, is that which is traversed during 2.0 seconds for perception and reaction, plus an additional 1.0 second to actuate braking or to

accelerate to regulate speed. By referring to *Fig. 5.5*, the sight triangle is determined by the minimum distances along the road. For instance, if highway A has a speed limit of 50 mph and highway B has one of 30 mph, it would require an unobstructed sight triangle, with legs extending at least 220 ft and 130 ft, respectively, from the intersection, based merely on the average distance traveled in 3 seconds.

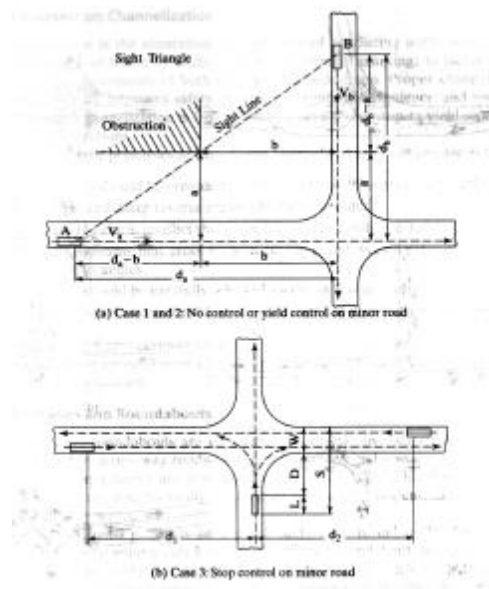

Fig. 6.5 Sight Triangle (AASHTO 2001)

These minimum distances will permit a vehicle on either road to change speeds before reaching the intersection, but this fact by itself does not imply that the intersection is safe.

There can be potential danger to vehicle operators on such intersections, especially when successions of vehicles are approaching the intersection, when time is sufficient to avoid only a single vehicle. Because the distance covered in 3 seconds ranges from 70% of the safe stopping distance at 20 mph to only 36% at 70 mph, the use of sight triangles for design purposes must be approached with caution.

A safer design for such intersections should allow drivers on both highways to see the intersection and traffic in sufficient time to stop the vehicle before reaching the intersection. The safe stopping distances in this case are the same as those used for designing any other section of highway.

6.5 Interchanges

Interchanges are combinations of ramps and grade separations designed as a system of interconnecting roadways to separate the turning and through movements at the junction of two or more roads. They provide the greatest efficiency, safety and capacity for handling large volumes of traffic in these situations. Interchange design is a special form of intersection design. The traffic interchange is the best solution available to the problems encountered in intersections at grade, as it separates the major crossing movements and enables maximum traffic volumes to operate uninterrupted on at least the freeway. Crossing conflicts are eliminated and turning conflicts are minimized depending on the type and degree of development of the interchange, and on the degree of access limitation imposed. Interchanges can be provided between freeways, between freeways and arterial roads, and between arterial roads. The general principles of design are similar but standards for clearance, curvature, sight distance and visibility depend on the standard and the design speed of the roadway to which the element of the interchange connects. Each interchange is an individual problem and even standard types require customization to suit a particular site. Consistency of form assists in driver understanding and the design must be considered in conjunction with the design of adjacent interchanges. An interchange or series of interchanges on a route through an area may affect large adjacent areas or even the entire community. Interchanges should therefore be located and designed so that they will provide the best possible traffic service consistent with community interests. To this end all interchanges should provide for flexibility of operation and be subject to reasonably easy modification if required by future traffic patterns. When interchanges are required at relatively close spacing, the weaving maneuvers between the interchanges may limit capacity. Weaving occurs when an entry ramp is followed by an exit ramp within a distance of about 1.5km. Weaving involves lane changing as well as merging and diverging. Longer distances between the entry and exit ramp results in freeway capacity being limited by merge and diverge capacity. The influence of lane changing is not the limiting factor as more opportunities to change lanes arise on longer stretches of road. Weaving may be reduced or eliminated by special design features. Freeway capacity may be modeled by use of the Highway Capacity Manual (either using manual calculation or HCS 2000 software). Microscopic simulation software such as Paramics or Aimsun may also be used to assess freeway operating conditions under different traffic loadings and geometric layout options.