

Power Quality Monitoring and Solutions

Getachew Biru (Dr.-Ing)

Overview

1. Introduction
2. Power Monitoring
3. Mitigation equipment
4. Wiring and Grounding

Introduction

There are three important steps in solving and mitigating power quality problems:

- 1. Diagnosis:** analyze the symptoms of a power quality problem to determine its cause.
- 2. Identify the element** that is producing the electrical disturbance.
- 3. Treat the symptoms** of the power quality problem by the use of power conditioning equipment.

Introduction

In Diagnosis task the following questions need to be answered:

- What is the type of PQ problem ?
- What causes the power quality problem?
- How much is the level of the PQ problem?
- Is the source located in the utility's transmission or distribution system or inside the end user's facility (load side)?

Introduction

- The Power Quality Evaluation Procedure

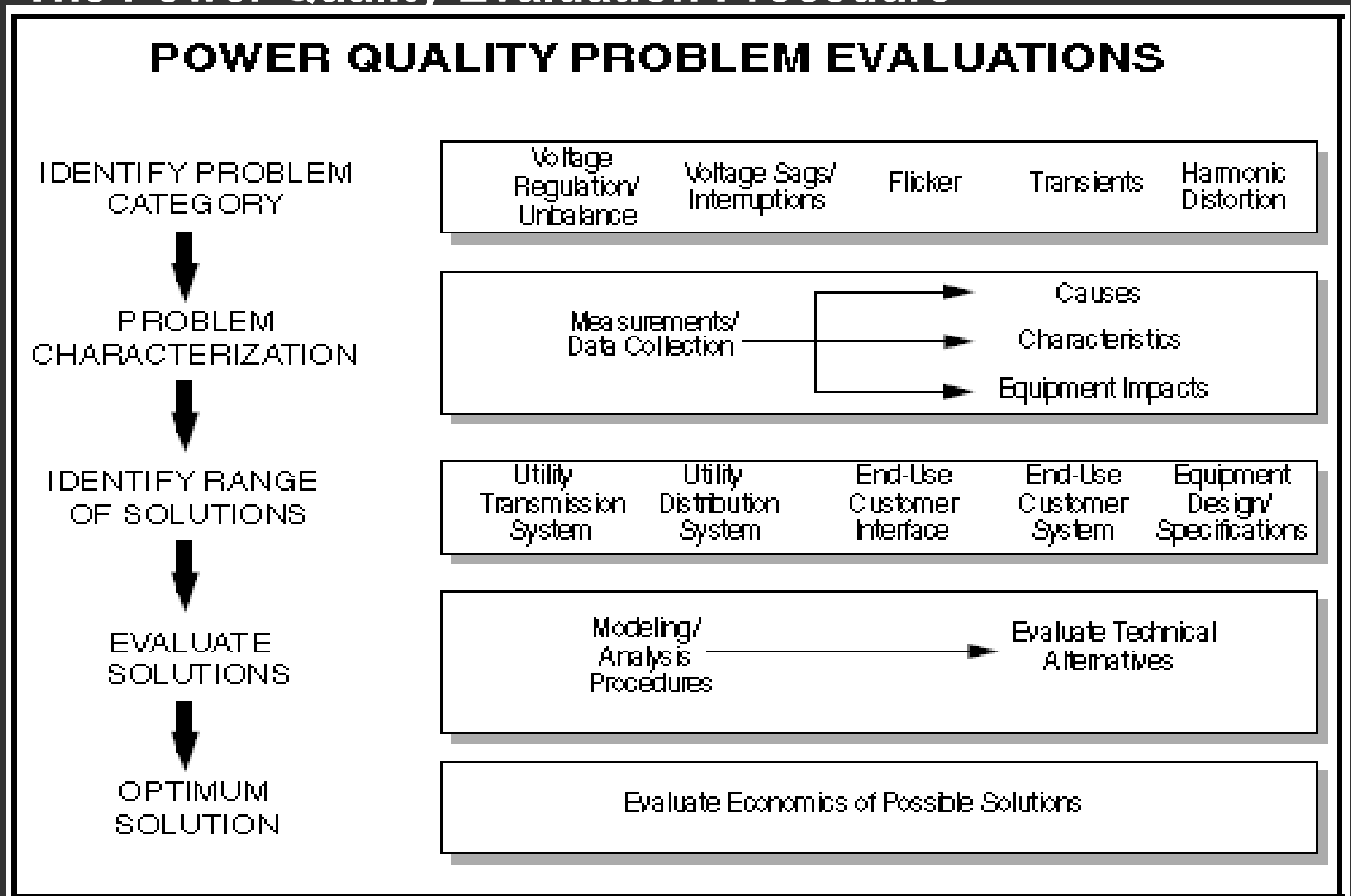

Power Quality Monitoring

Introduction of PQ monitoring (PQM):

1. PQM is the process of gathering, analyzing and interpreting raw measurement data into useful information.
2. PQM is done to improve the system-wide power quality performance.
3. Data usually measured is the voltage and current but is not limited to these quantities.

Power Quality Monitoring

Common Manifestations of Power Quality:

- Low power factor
- Harmonics - current & voltage distortions
- Frequency limits - under & over frequencies
- Steady state voltage limits - under & over voltages
- Transients
- Sags & Swells
- Unbalance
- Interruptions
- Flicker

Power Quality Monitoring

Symptoms of Harmonics:

- Nuisance tripping of switchgear
- Premature / frequent failure of equipment
- Mal function of equipment
- Overheating of cables, equipment
- Neutral conductor burn outs
- Low power factor
- Audible noise in cables, busbars, transformers

Power Quality Monitoring

Power Quality Monitoring also includes:

- Inspection of wiring and grounding.
- Inspection of equipment connections.

Power Quality Monitoring

Voltage –magnitude & shape

- Steady state limits
- Frequency
- Distortion
- Sags & Swells
- Transients
- Unbalance - magnitude & Phase

Current-magnitude & shape

- Magnitude
- Frequency
- Distortion
- Phase angle
- Transients
- Unbalance

Power Quality Monitoring

Strategy of Quality Monitoring includes:

- Measurements at some strategic locations should be done.
- Not possible to monitor at each and every point in the system.
- Can be expensive and hard to manage the data.

Power Quality Monitoring

Monitoring Selection:

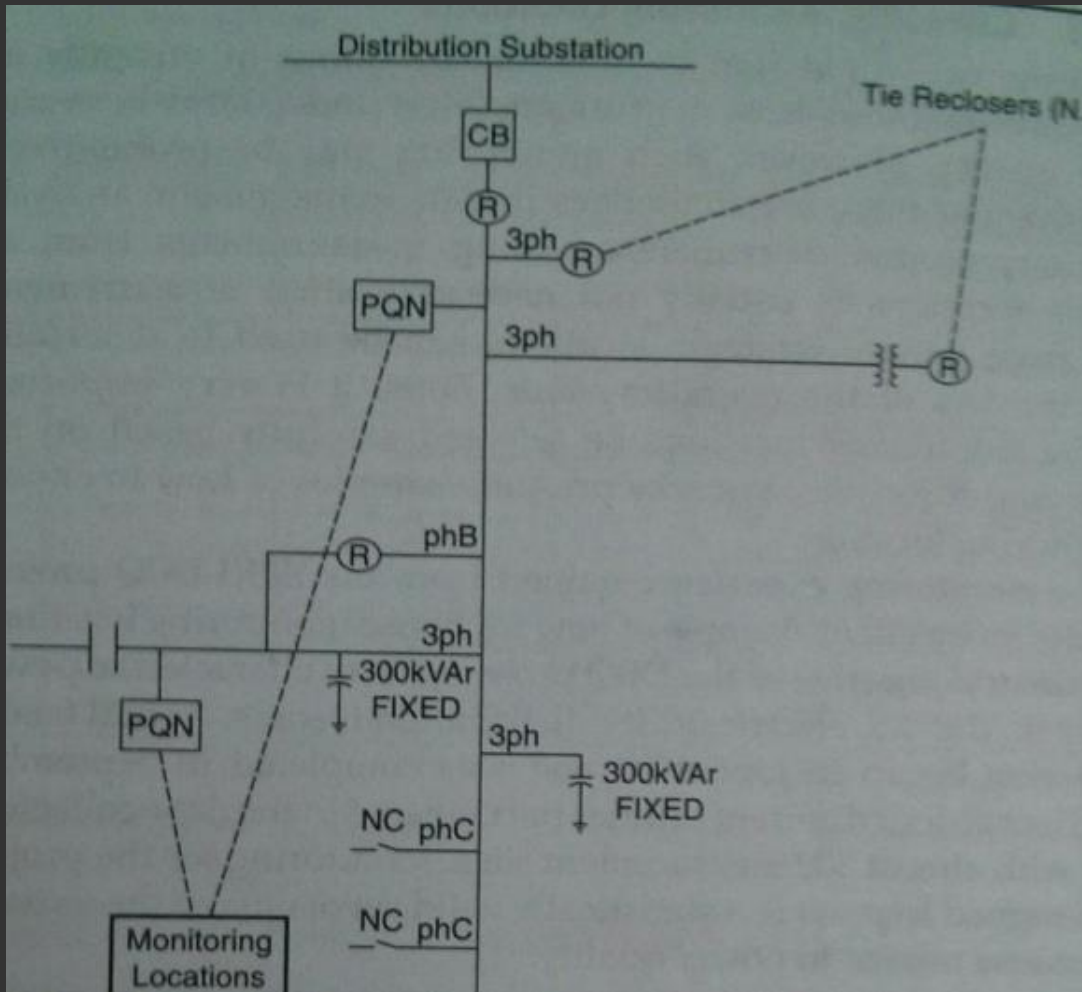

Where to monitor:

- Close to sensitive /critical equipment
- Close to source
- PQN / metering point
- Major Nodes / Branches

Power Quality Monitoring

Permanent power quality monitoring equipment:

➤ Digital fault recorders (DFRs):

- ✓ Record the voltage and current waveforms that characterize the event.
- ✓ Helps in characterizing disturbances like voltage sags, during power system faults.
- ✓ Can also capture periodic waveform.

Power Quality Monitoring

Voltage and current recorders

- The voltage recorder provides a trend that gives maximum, minimum and average voltage with a resolution of less than 2 seconds.
- Special-purpose power quality monitors which monitors simultaneously voltage and current.

Power Quality Monitoring

Special-purpose power quality monitors:

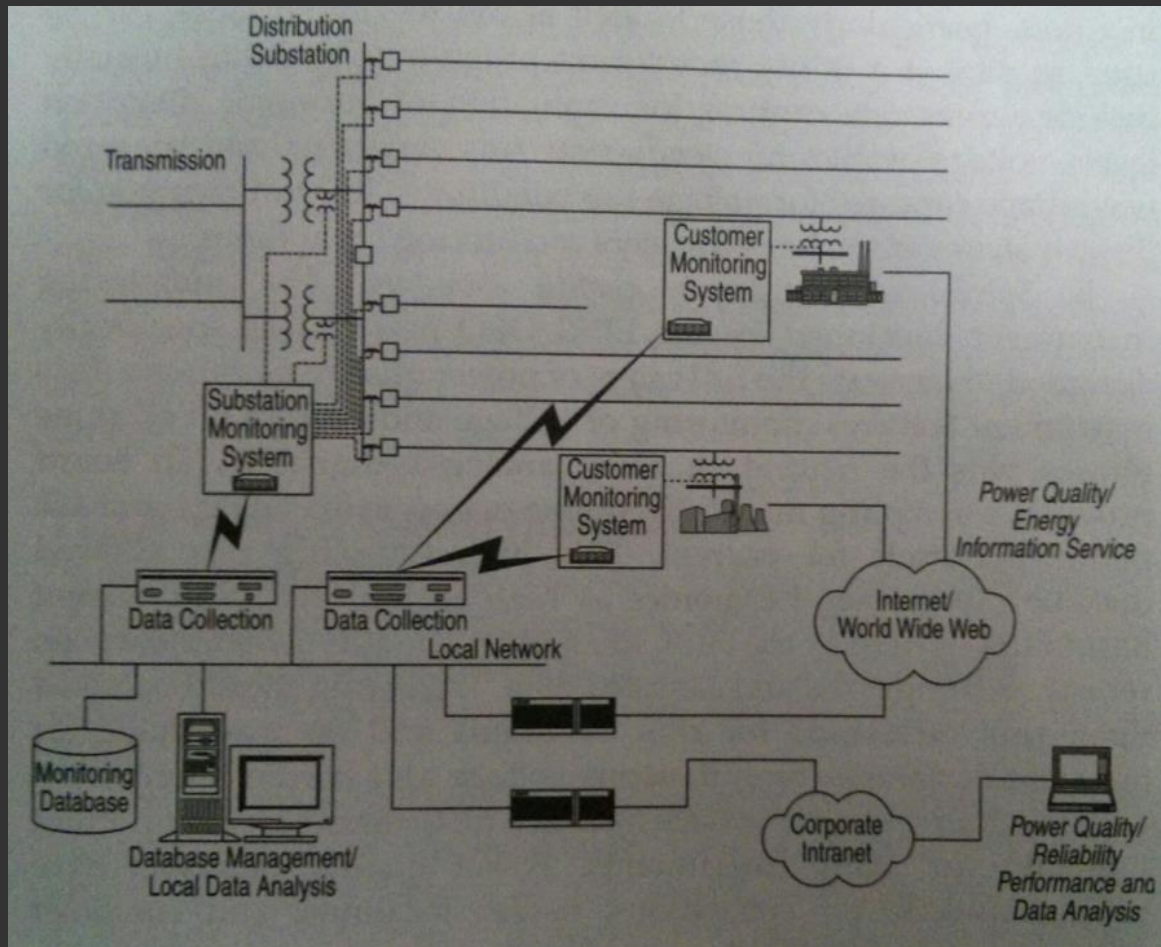

Data Analysis

- Collection of raw data
- Analysis of data

Mitigation equipment

The equipment can be divided into various categories including:

- Surge suppressors
- Harmonic filters
- Noise filters
- Isolation transformers
- Low-voltage line reactors
- Various line-voltage regulators
- Motor-generator sets
- Uninterruptible power supplies (UPSs)

Mitigation equipment

Surge suppressors (diverters)

- Surge suppressors protect sensitive equipment from being zapped by voltage surges or lightning strokes on the power system.
- They are the shock absorbers or safety valves of electrical power systems.
- They divert to ground or limit the transient voltage caused by lightning or switching surges to a level that will not harm the equipment they are protecting.

Mitigation equipment

Surge suppressors (diverters)

- Utilities specify and locate arresters near equipment they wish to protect, like transformers, distribution lines, and substation equipment.

Mitigation equipment

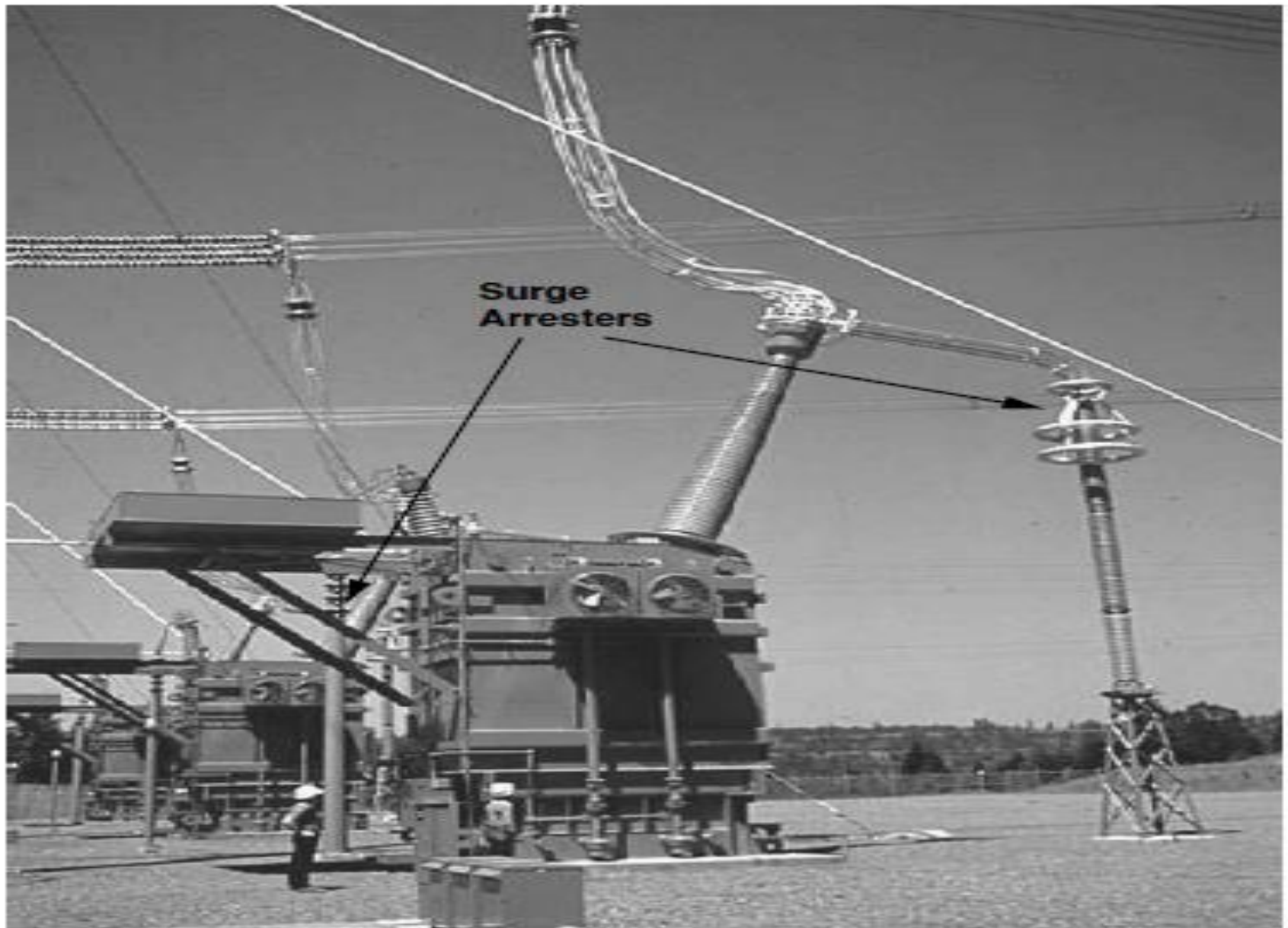

Mitigation equipment

Surge suppressors (diverters):

- There are two basic types of surge suppressors: **crowbar** and **voltage-clamping** devices.

Mitigation equipment

Crowbar devices. They have a gap filled with a material that acts like a short circuit to voltage transients.

These materials include air, special ionization gas, or a ceramic-type material like silicon carbide for low voltages or zinc oxide for medium and high voltages. The gap acts as an insulator when the voltage is normal.

The gap becomes a conductor (ionized) when the transient voltage exceeds the breakdown voltage of the material in the gap.

Mitigation equipment

Crowbar arrestor

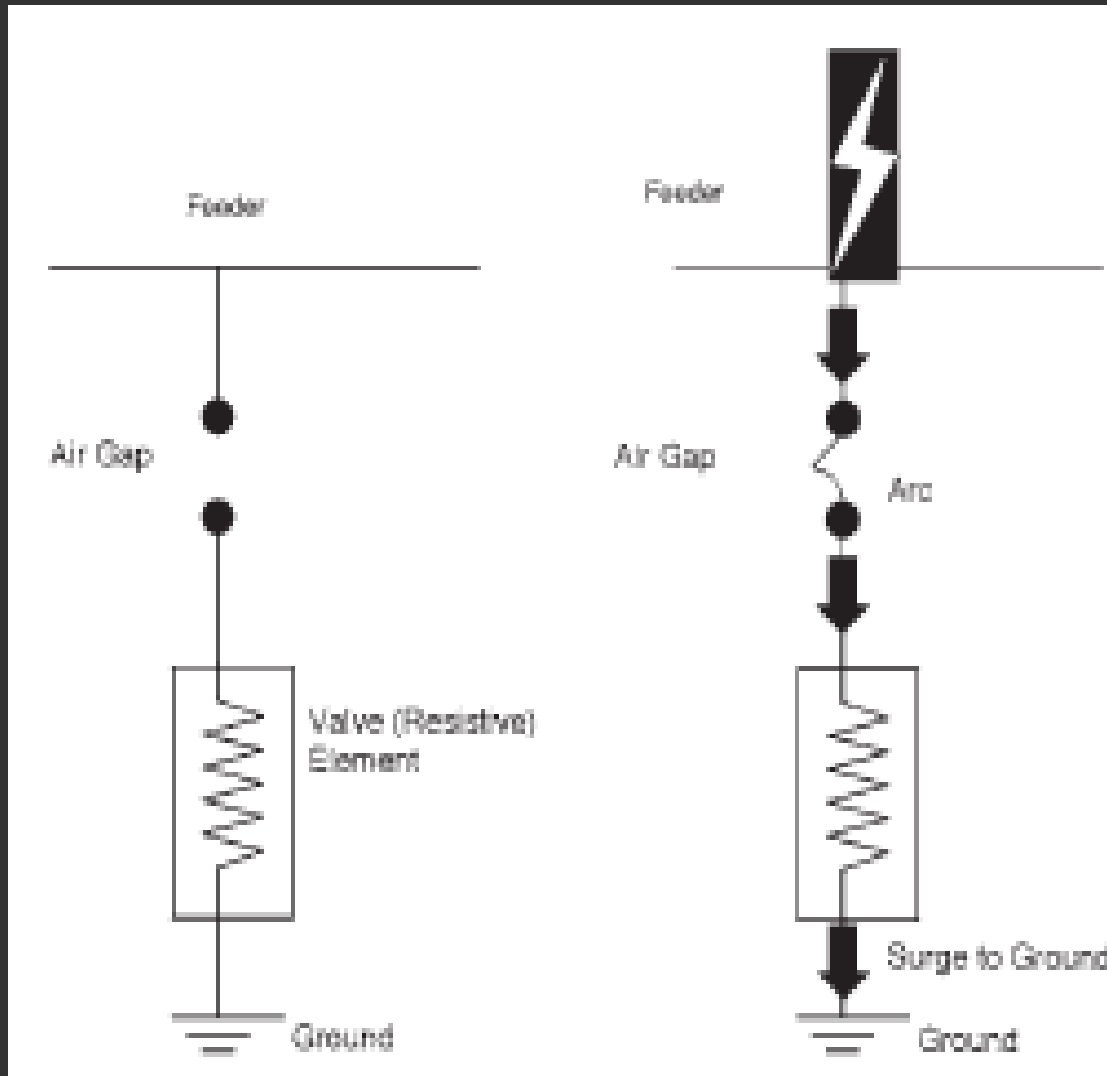

Mitigation equipment

- **Voltage-clamping devices.** Voltage-clamping surge suppressors usually contain a material that clamps the voltage of a transient.
- This material is a nonlinear resistor (varistor) whose resistance decreases as the voltage across it increases.
- They usually contain metal oxide varistors (MOVs) or silicon avalanche (zener) diodes that clamp, i.e., limit, excessive line voltage and conduct any excess impulse energy to ground.

Mitigation equipment

Clamping a transient voltage

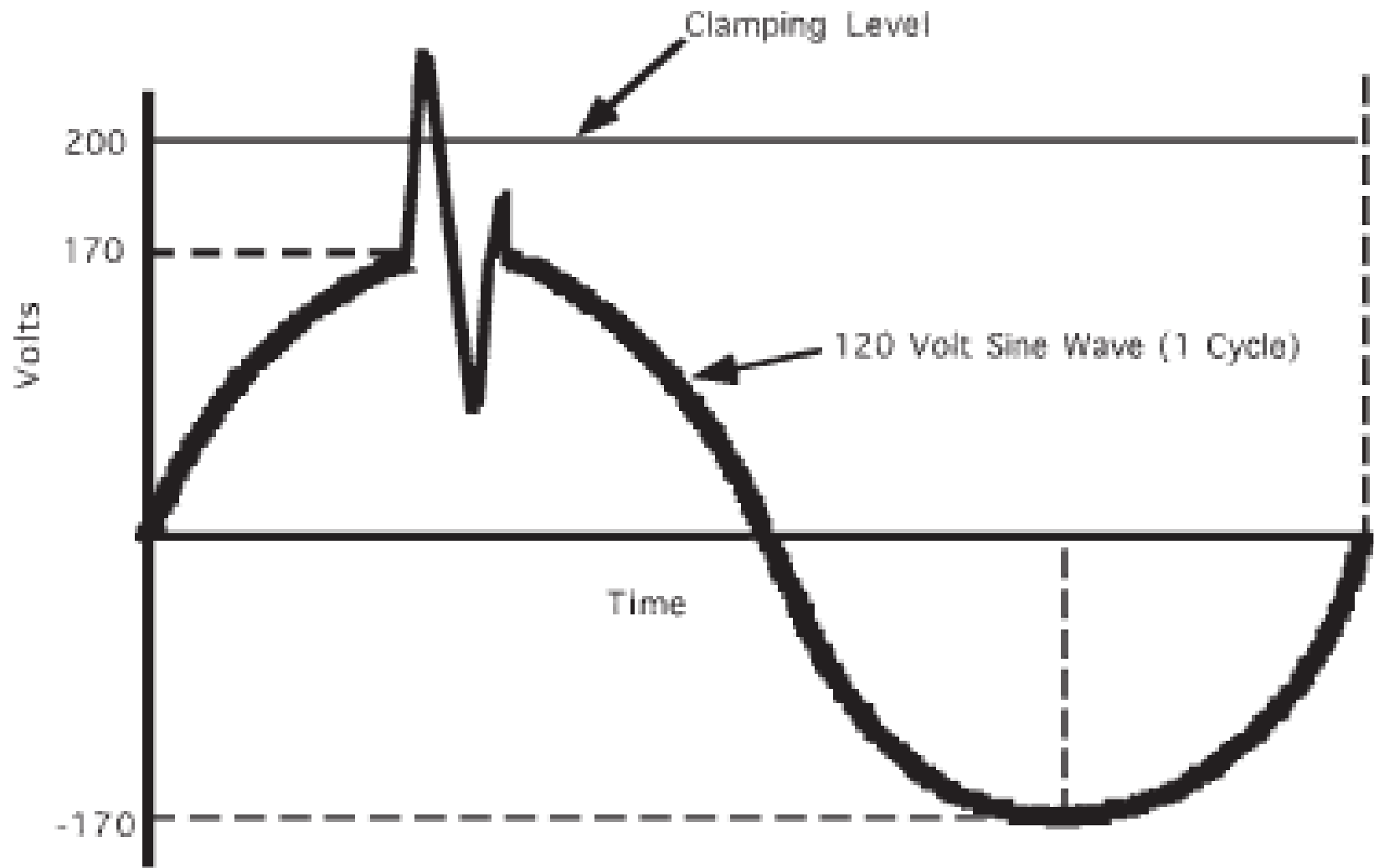

Figure 4.10 Clamping a transient voltage.

Mitigation equipment

Transient voltage surge suppressors (TVSS):

- End users locate surge suppressors inside their facilities, between the power outlet and sensitive electronic equipment, such as computers, adjustable-speed drives, and communication devices, or at the main power supply panel board.

Mitigation equipment

- Transient voltage surge suppressors (TVSS)

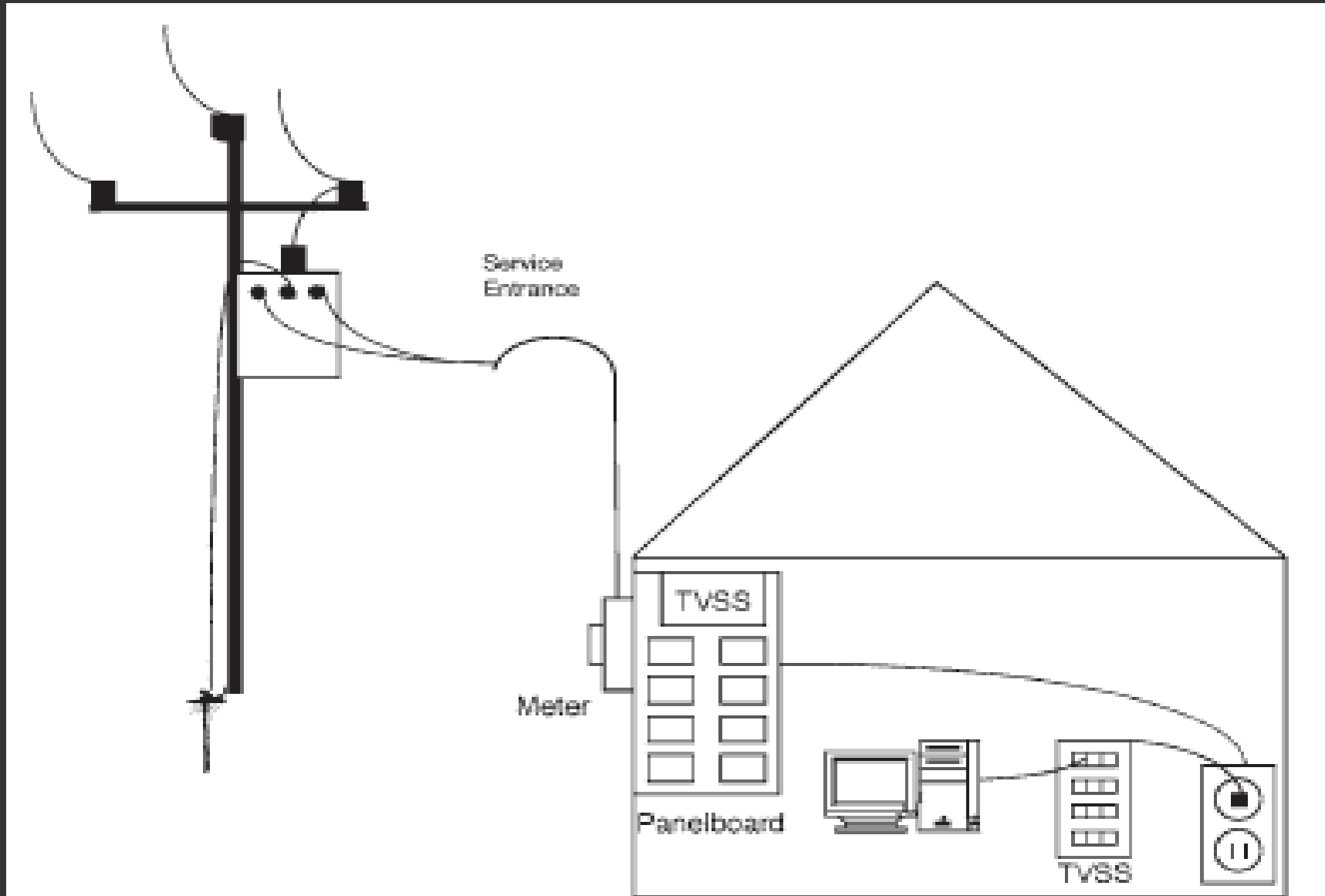

Mitigation equipment

Transient voltage surge suppressor

TVSS connected to between equipments and power outlet

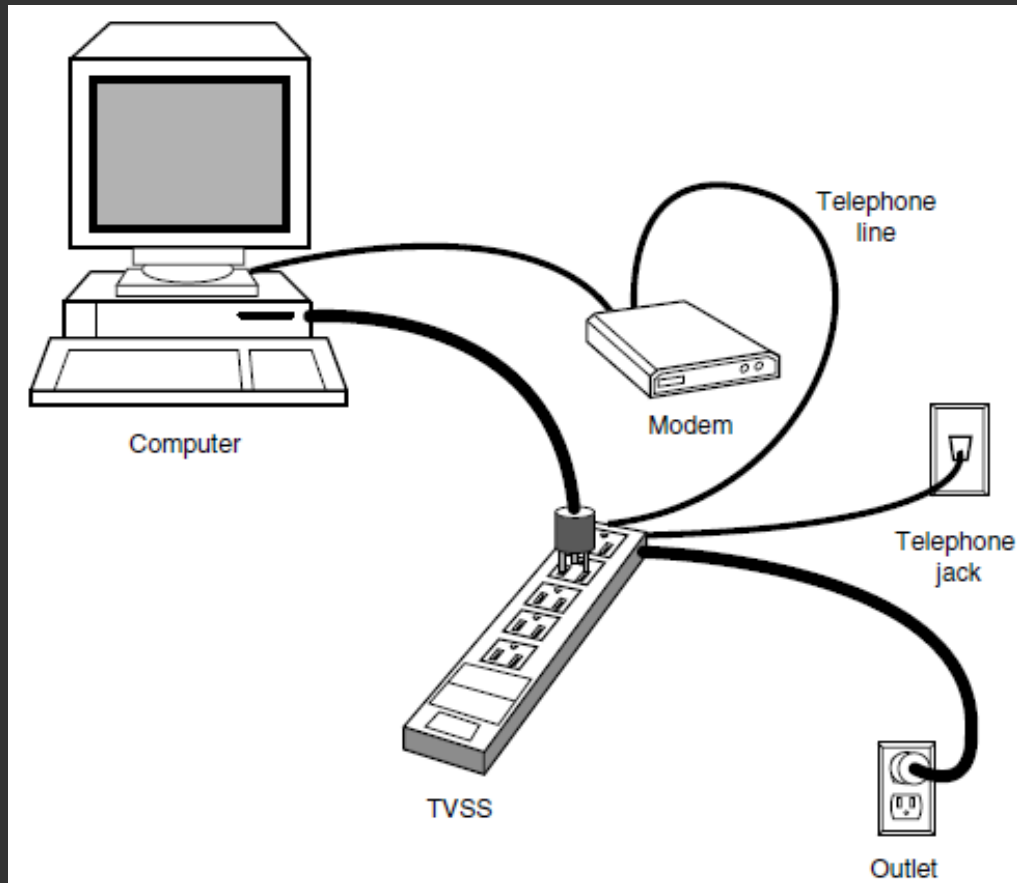

Surge Arrestors Ratings

- Surge arresters have both a voltage rating and a class, or type.
- The important voltage rating is the maximum continuous operating voltage (MCOV), which is the steady-state voltage the arrester could support indefinitely.
- The MCOV should be at least 1.05-1.15 times the system's nominal line-to-ground voltage. There are some cases like distribution feeders with poor voltage regulation, which might require a higher MCOV.

Surge Arrestors Ratings

- The **energy capability** of an arrestor determines its ability to dissipate switching surges.
- Surge arresters have a **switching surge energy** discharge capability. The vendor may provide this value as kJ per kV of MCOV.
- The energy capability may be increased by using two or more columns of metal oxide in parallel.

Surge Arrestors Ratings

- Rating of an arrestor

System nominal voltage		= 66kV
Rated normal Voltage	= 66×1.1	= 72.6kV
Continuous Operating Voltage (kV) rms		= 48.0kV
Normal Discharge Current (8 /20 μ s) kA		= 10kA
1/50 Impulse Spark over Voltage		= 163.5kV
Frequency (Hz)		= 50Hz
Type		= outdoor

Mitigation equipment

Noise filters

- All filters, including noise filters, prevent unwanted frequencies from entering sensitive equipment. They do this by using various combinations of inductors and capacitors. Inductors produce impedances that increase proportionately to the magnitude of the frequency.
- Capacitors produce impedances that reduce proportionately to the magnitude of the frequency.

Mitigation equipment

Noise filters

- Noise filters are low-pass filters. Inductors in noise filters allow the low-frequency fundamental signal of 50-Hz power to pass through.
- The capacitors in parallel with the inductors divert the high frequencies of common-mode and normal-mode noise to ground. Figure shows the components of a low-pass noise filter.

Mitigation equipment

- Noise filters

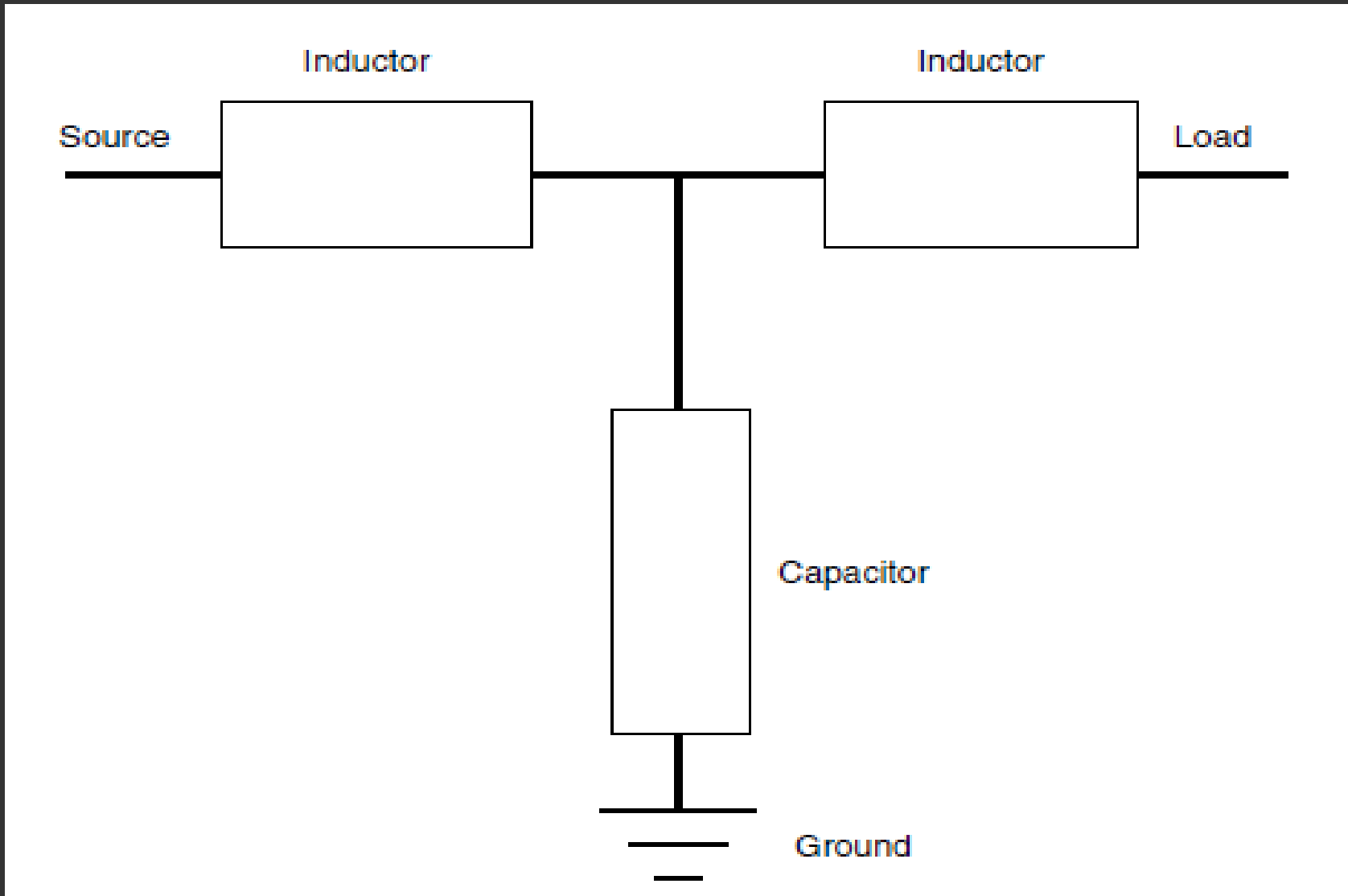

Mitigation equipment

Isolation transformers

- Shielded isolation transformers are very popular power-conditioning devices. They isolate sensitive loads from transients and noise caused by the utility. They can also keep harmonics produced by end-user nonlinear equipment from getting onto the utility's system.

Mitigation equipment

Isolation transformers

- Isolation transformer components include a primary and secondary winding with a magnetic core and a grounded shield made of nonmagnetic foil located between the primary and secondary winding.

Mitigation equipment

Isolation transformers

- The electrostatic shield is simply a grounded single turn of conductive nonferrous foil placed between coils to divert primary noise to ground.
- Any noise or transient from utility is transmitted through capacitance between primary and shield and on to ground.

Mitigation equipment

- Isolation transformers

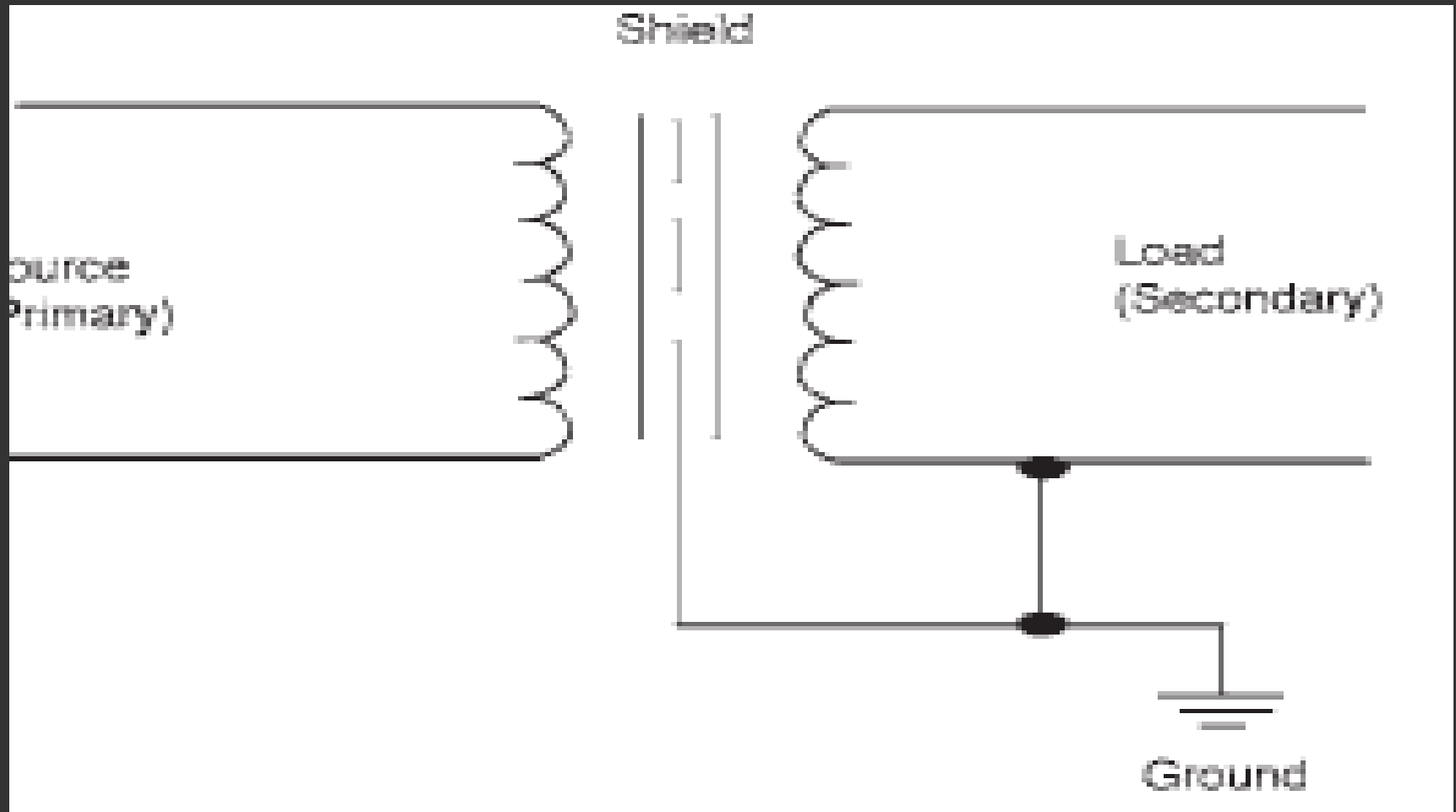

Mitigation equipment

Line-voltage regulators

- Line-voltage regulators are transformers specially designed to regulate, control, or hold the output voltage constant when the input voltage changes.

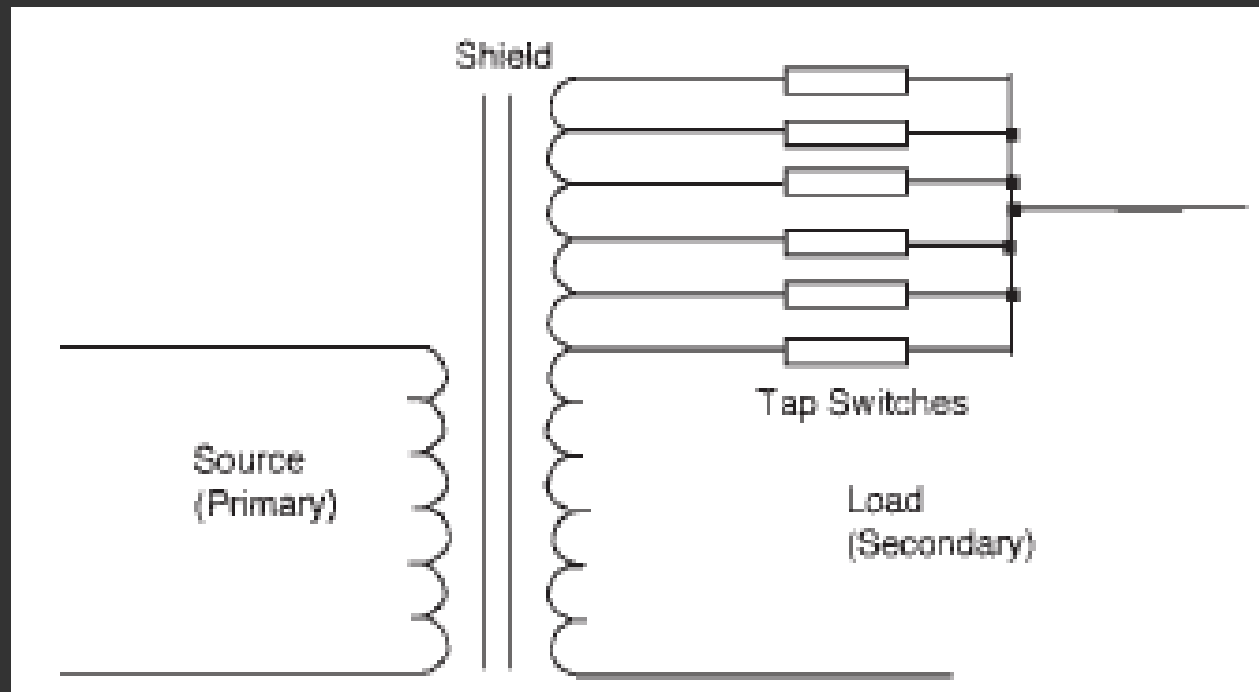

Mitigation equipment

Buck-boost regulator. regulates a voltage by adding transformer windings that either reduce (buck) or increase (boost) the voltage.

They compare the output voltage to the input voltage and use electronic solid-state switches, like thyristors, to switch the windings from the buck to the boost state or from the boost to buck state to keep the output voltage constant. They can maintain the output constant within ± 1 % for a 15 to 20 % change in input voltage.

Mitigation equipment

Buck-boost regulator.

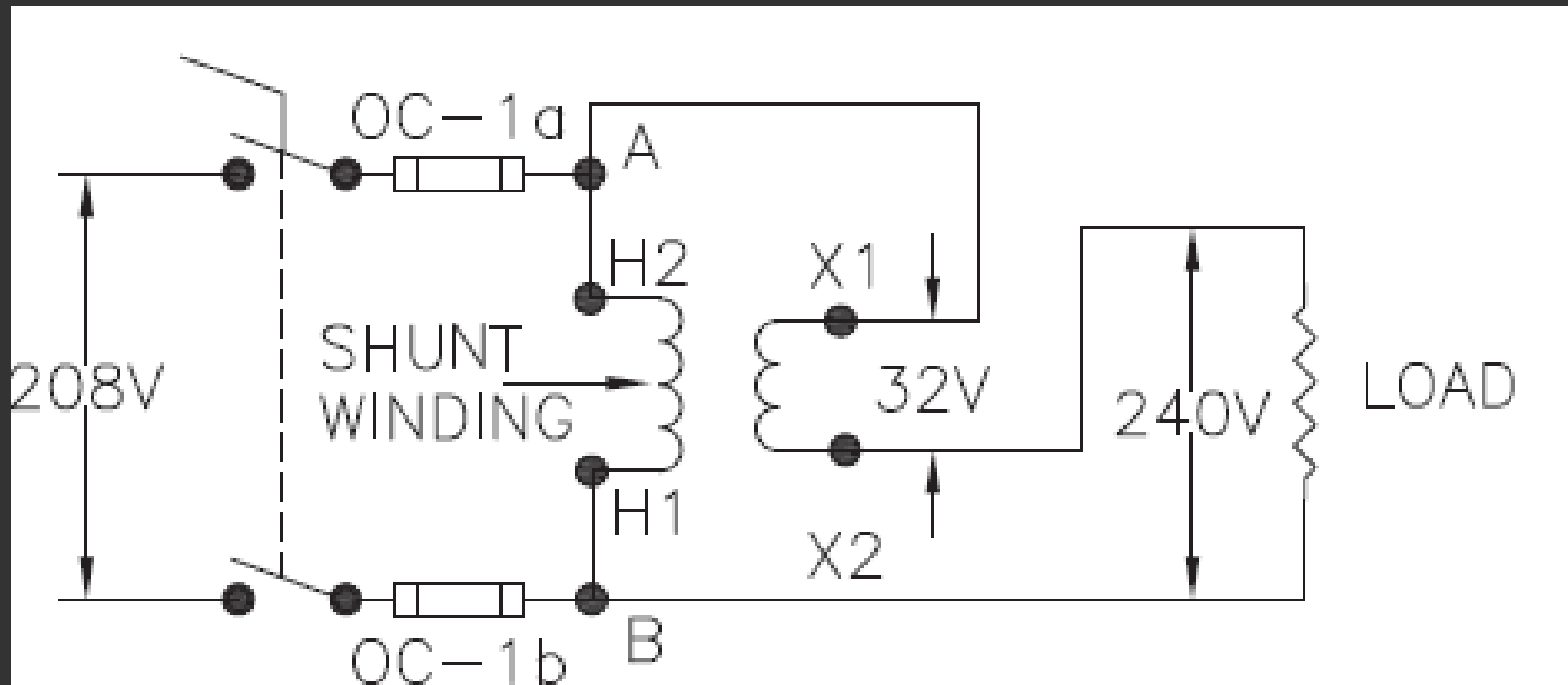

Mitigation equipment

- **Constant-voltage transformer (CVT)**. It provides a constant output voltage when the input voltage increases above or decreases below the nominal voltage.
- It works on the principle of resonance and core saturation. Resonance occurs when the impedance of the capacitor equals the impedance of the inductor. In this case a capacitor is in series with the induction of the CVT coil.

Mitigation equipment

- Constant-voltage transformer (CVT).

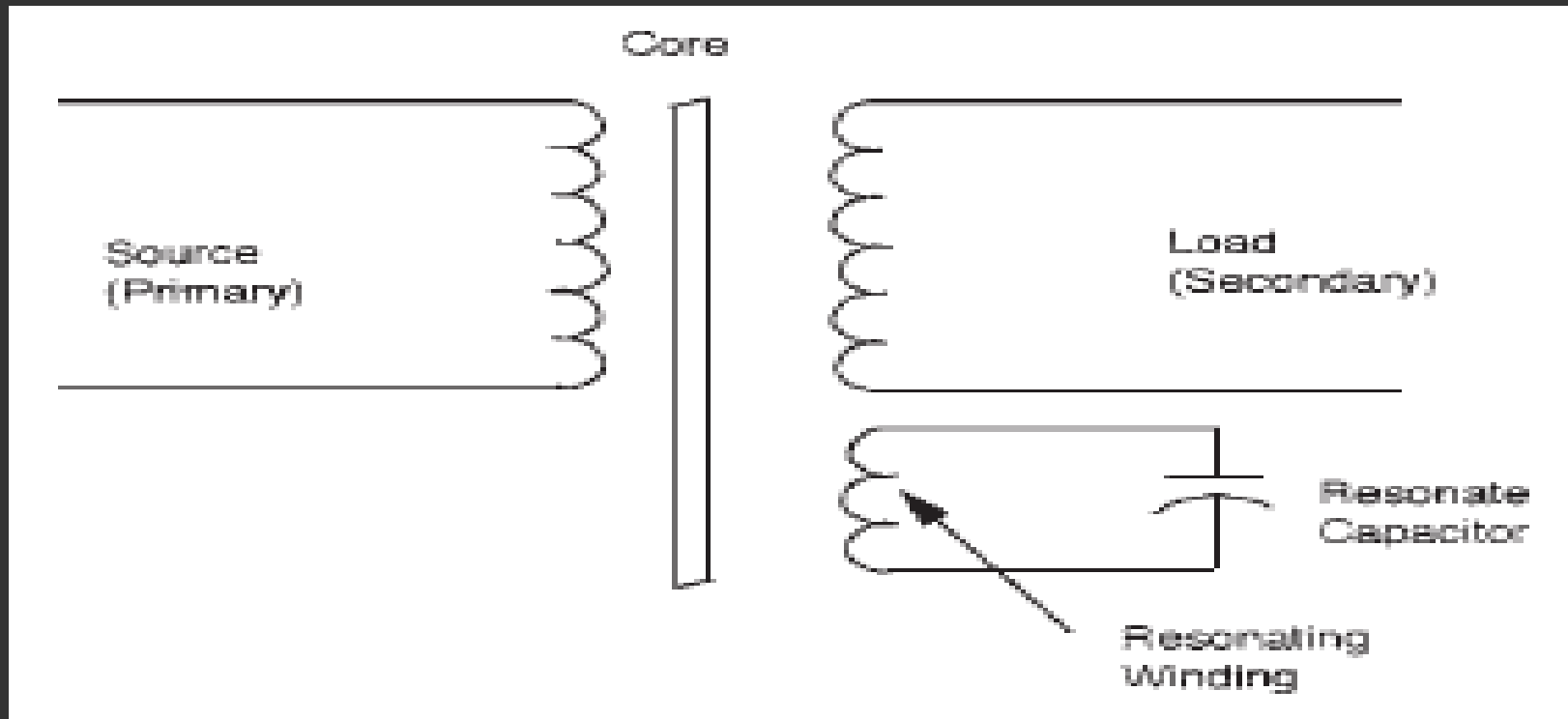

Mitigation equipment

Motor-generator (M-G)

- If power is interrupted, the generator keeps supplying power to critical loads by using diesel or natural gas as the fuel.

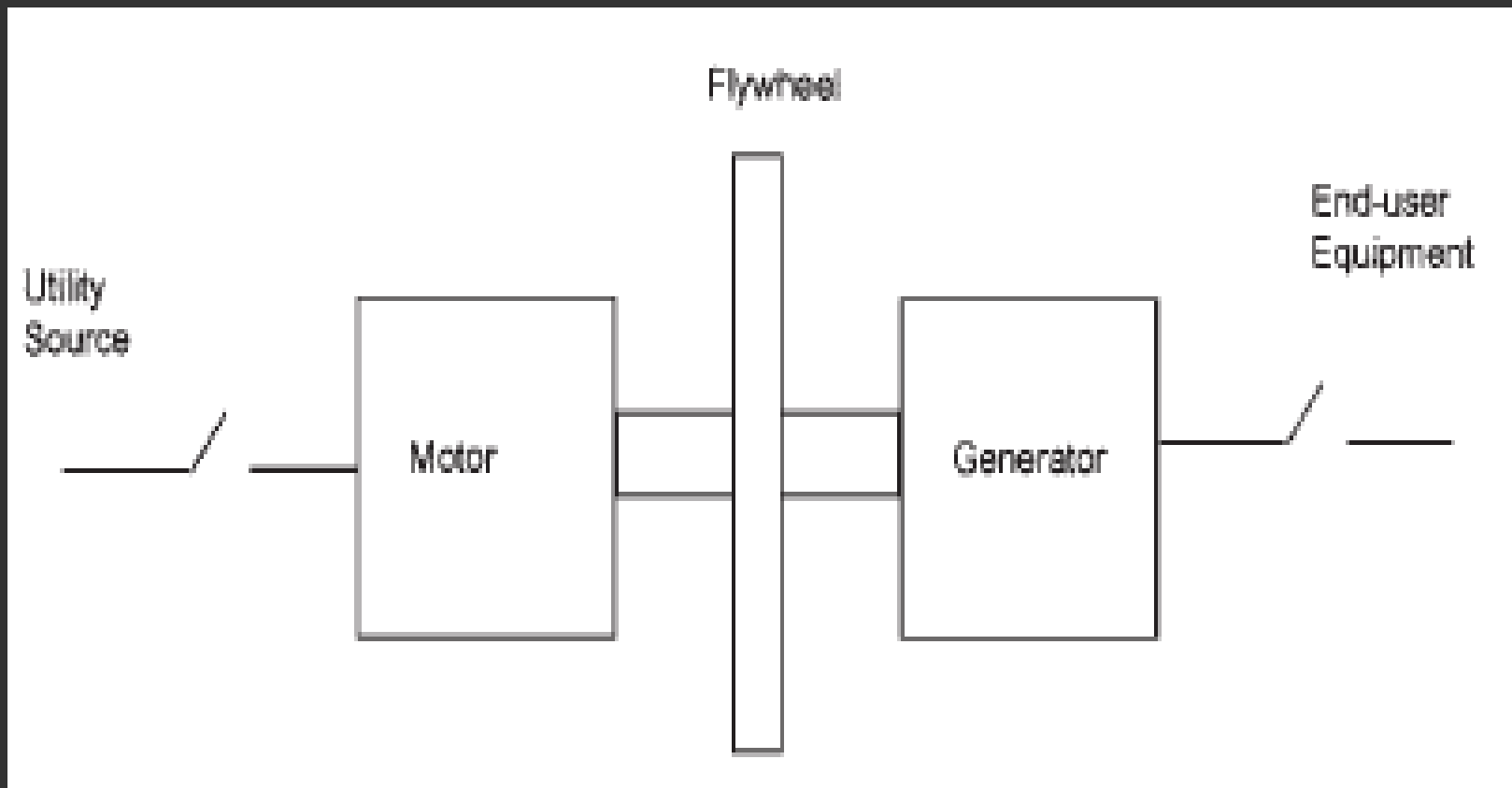

Mitigation equipment

- **Static VAR compensators** use a combination of capacitors and reactors to regulate the voltage quickly.
- They replaced old-style synchronous condensers. Synchronous condensers supplied continuous reactive regulation but were too expensive to buy, operate, and maintain.
- SVARs are less expensive to operate & maintain. They use solid-state switches that insert the capacitors & reactors at the right magnitude to keep the voltage from fluctuating.

Mitigation equipment

Static VAR compensators

- Utilities use SVCs to keep the voltage from sagging during a fault on a transmission line.

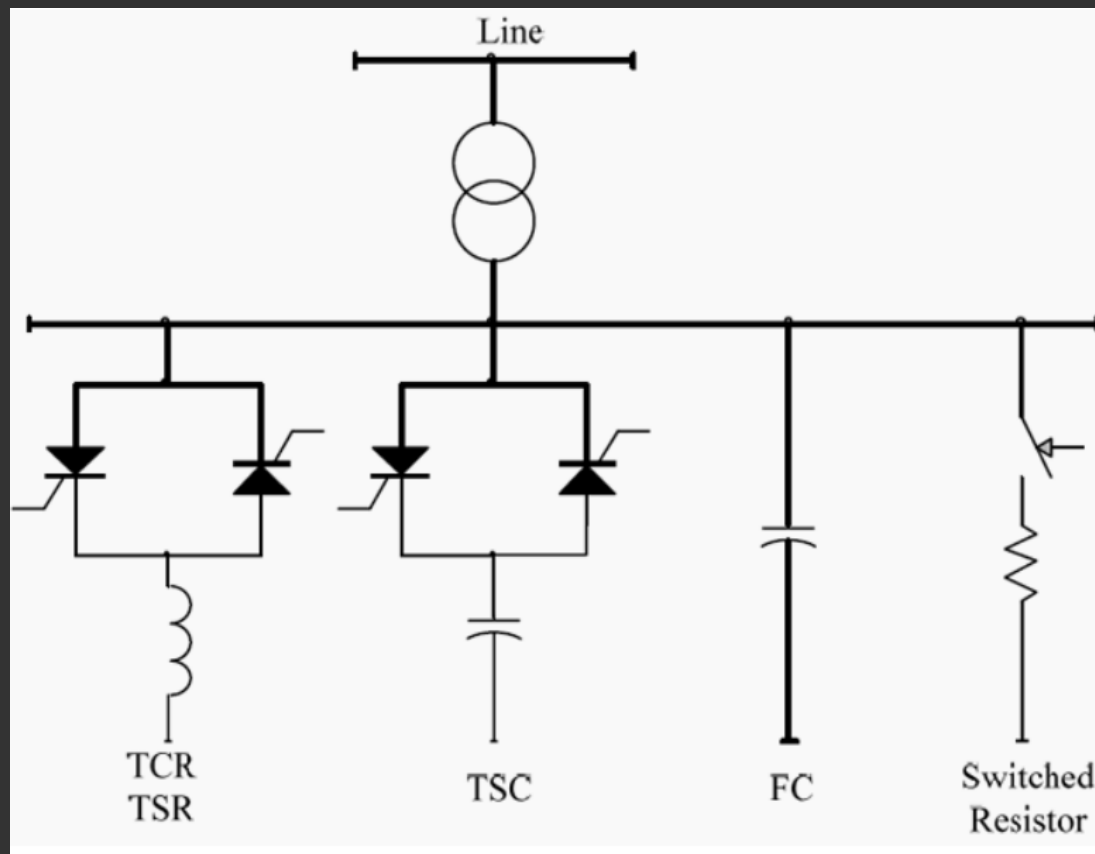

Mitigation equipment

Uninterruptible power supply (UPS)

- A UPS conditions the voltage and power. It conditions the voltage by providing a constant voltage even during a voltage dip (sag).
- It conditions the power by providing a source of power during an outage.
- The basic building blocks of a UPS system include the battery, an inverter, and a rectifier.

Mitigation equipment

Uninterruptible power supply (UPS)

They are connected in different configurations: on line, off line.

- **An on-line UPS**, as shown in Figure, provides a fully charged battery backup available all the time. It has the advantage of conditioning the power from surges, sags, or outages continuously.
- It has the disadvantage of shorter battery life because the continuous charging and discharging of the battery wears the battery out.

Mitigation equipment

Uninterruptible power supply (UPS): On-line UPS configuration

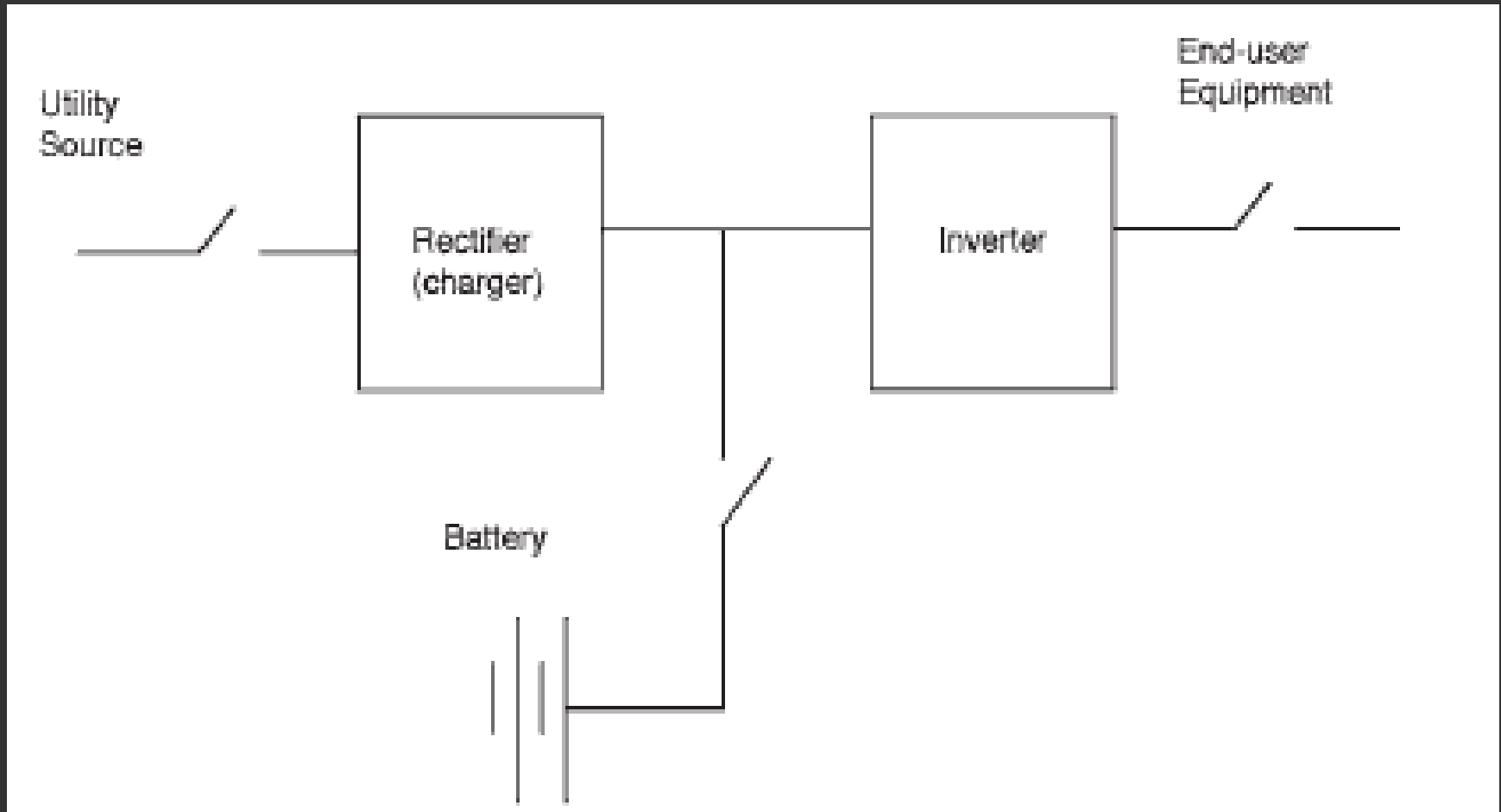

Mitigation equipment

Uninterruptible power supply (UPS)

- **An off-line** or standby UPS, turns off the inverter connected to the battery during normal operation. The UPS turns the inverter on to convert dc power to ac only during an outage.
- Consequently, it saves battery life by not continuously charging and recharging the battery.
- However, there is a time delay of 4 to 10 milliseconds to engage the UPS during an interruption.

Mitigation equipment

Uninterruptible power supply (UPS): Off-line (standby) UPS configuration.

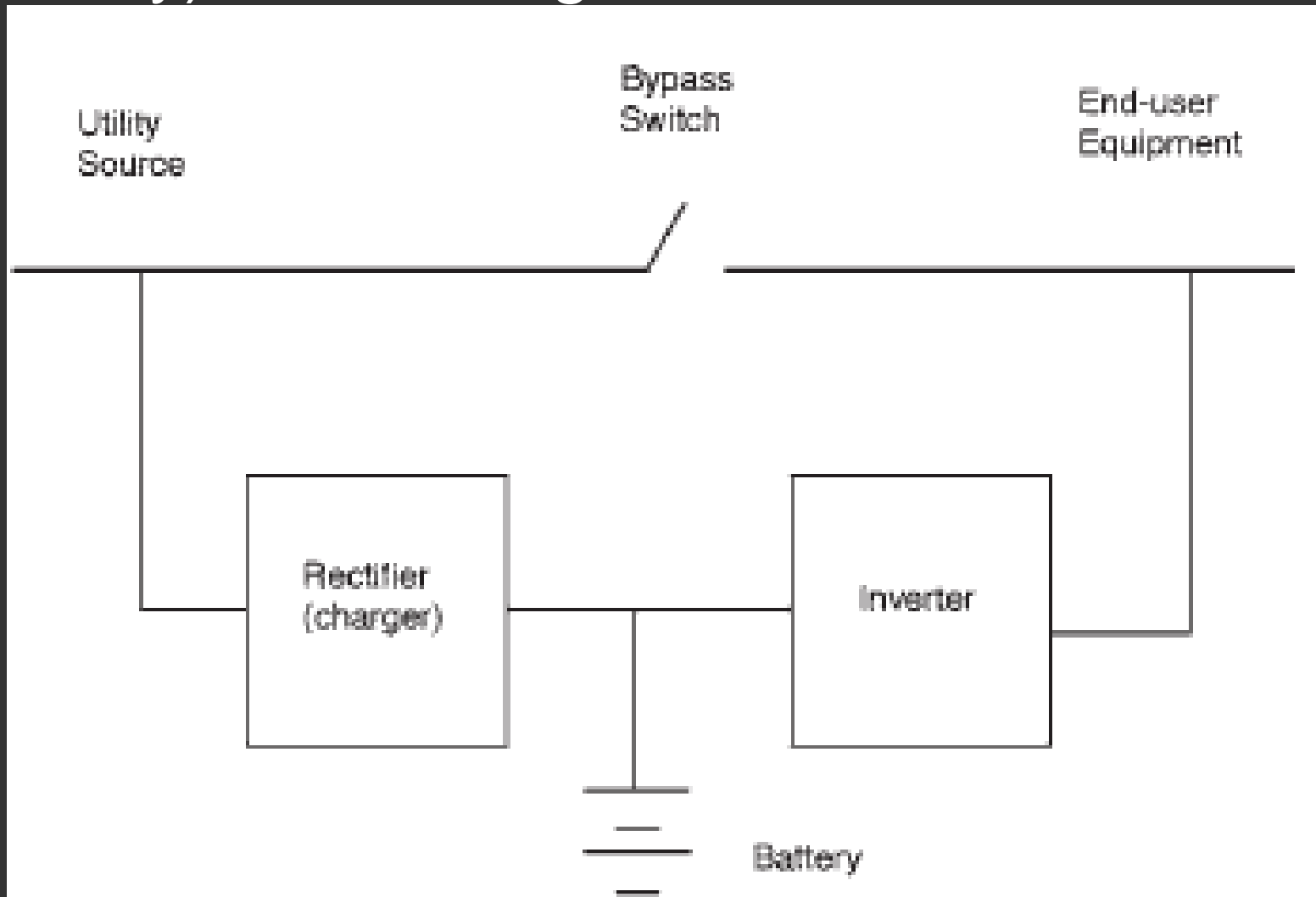

Mitigation equipment

- **Harmonic Filters:** Utilities use harmonic filters on their distribution systems, while end users use harmonic filters in their facilities to keep harmonic currents from causing their electrical equipment to overheat and to detune resonating circuits.
- The two basic types of harmonic filter configurations are **series and shunt filters**.
- The series filter refers to the filter made of a capacitor and inductor connected in parallel with each other but in series with the load.

Mitigation equipment

- **Passive filters.** Passive harmonic filters use static inductors and capacitors. Static inductors and capacitors do not change their inductance (henries) and capacitance (farads) values. They are designed to handle specific harmonics.
- They are called passive because they do not respond to changes in frequency.
- They may become ineffective if the harmonics change because the load changes.

Mitigation equipment

- **Harmonic Filters:**
- This type of filter provides a high-impedance path for harmonic currents and blocks them from reaching the power supply but allows the fundamental 50-Hz current to pass through. This type of configuration has the drawback of having to carry the full load current.

Mitigation equipment

Harmonic Filters

- The **shunt filter** that consists of a capacitor and inductor connected in series with each other but in parallel or shunt with the load.
- It provides a low-impedance path for harmonic currents & diverts them harmlessly to ground.
- The shunt filter is more common & less expensive, because it doesn't have to carry the full load current.

Mitigation equipment

Harmonic Filters

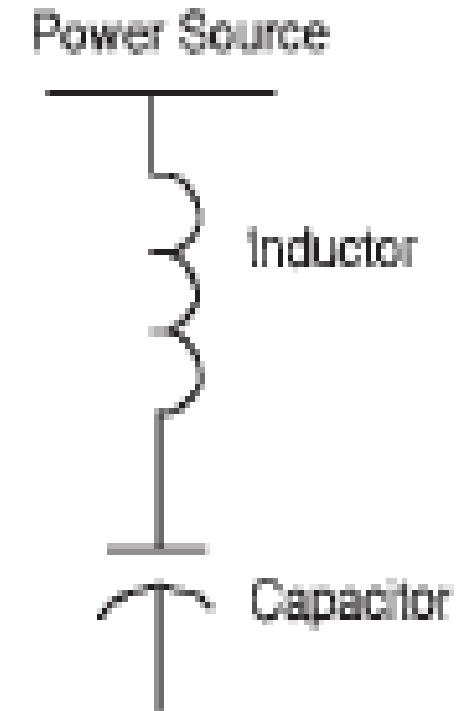

Harmonic Source

Shunt Filter

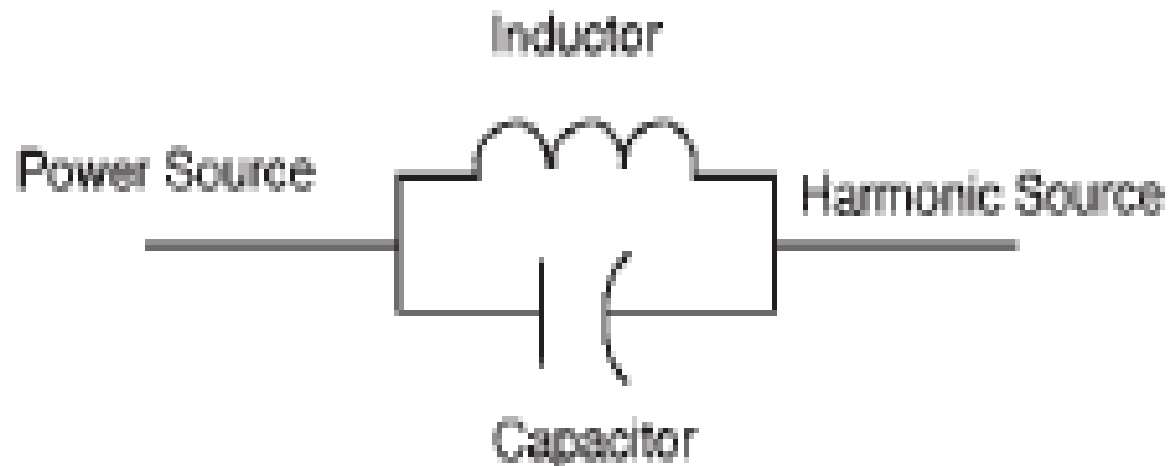

Series Filter

Mitigation equipment

- **Active filters.** Active harmonic filters are sometimes referred to as *active power line conditioners* (APLCs). They differ from passive filters in that they condition the harmonic currents rather than block or divert them.
- Active harmonic filters use electronic means to monitor and sense the harmonic currents and create counter harmonic currents. They then inject the counter-harmonic current to cancel out the harmonic current generated by the load.

Active Filter

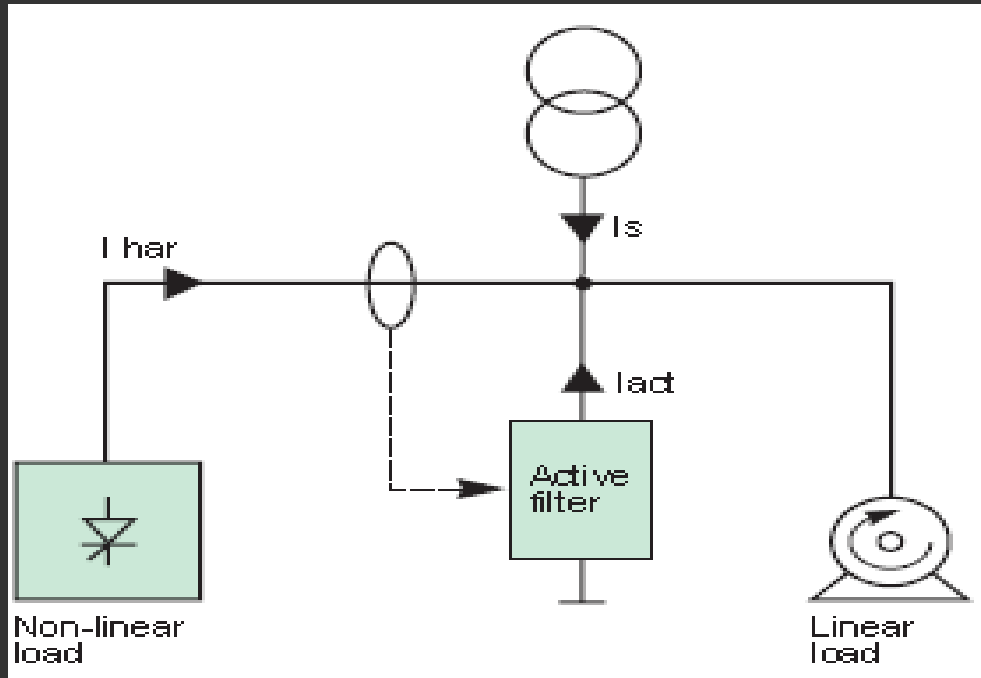

- The active filter injects, in opposite phase, the harmonics drawn by the load, such that the line current I_s remains sinusoidal.

Active Filter

The parallel active filter is modeled like a controlled current source connected in shunt to the load to supply the compensation current,

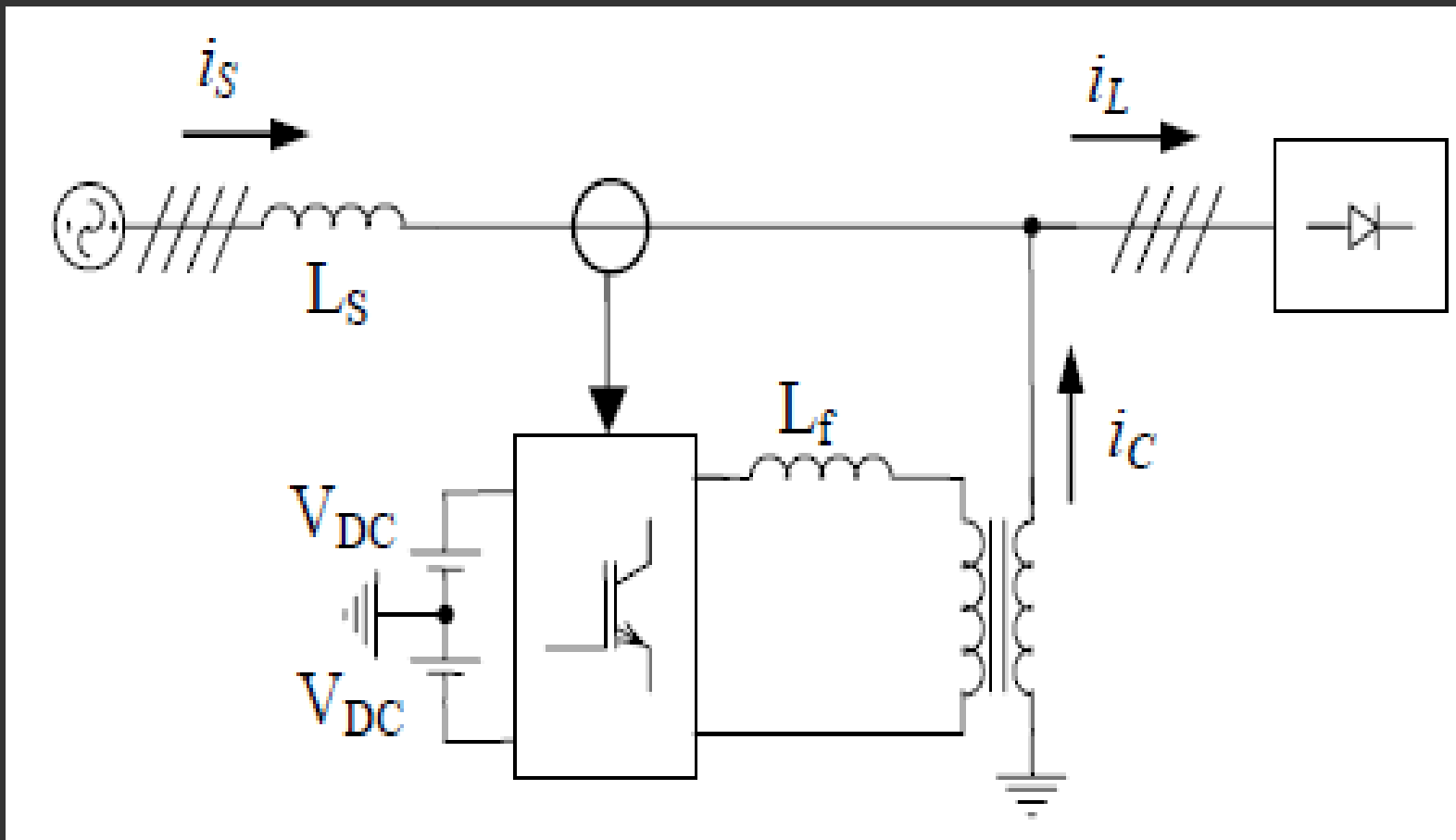

Active Filter

Make a comparative analysis of passive filter, and active filter.

Dynamic Voltage Restorer (DVR)

Dynamic Voltage Restorer is series connected voltage source converter based compensator which has been designed to protect sensitive equipment like Programmable Logic Controllers (PLCs), adjustable speed drives, computers etc from voltage sag. Its main function is to monitor the load voltage waveform constantly by injecting missing voltage in case of sag.

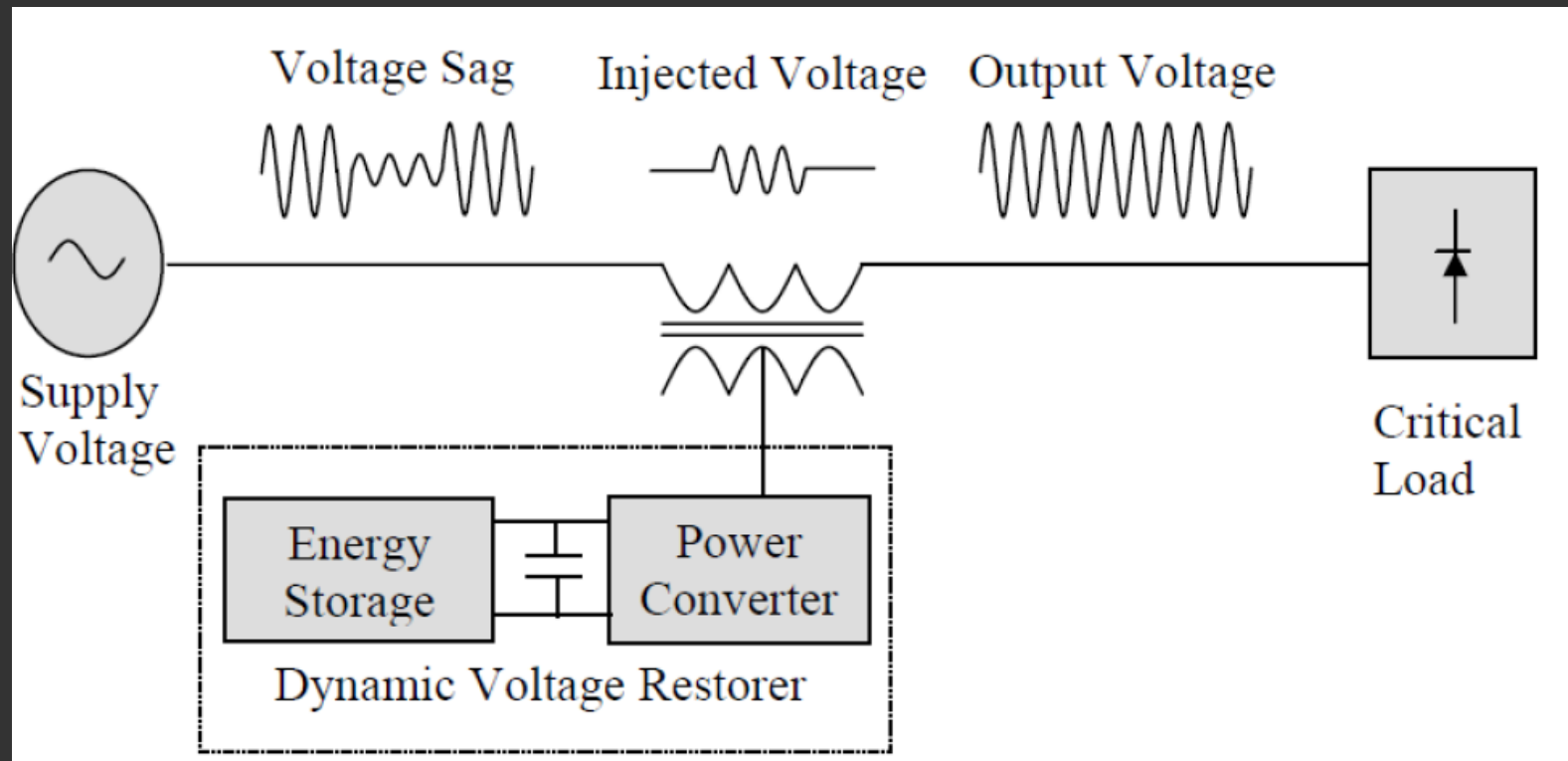

Dynamic Voltage Restorer (DVR)

- The basic idea of the DVR is to inject a controlled voltage generated by a converter in a series to the bus voltage by means of an injecting transformer.
- A DC capacitor bank which acts as an energy storage device, provides a regulated dc voltage source. A DC to Ac inverter regulates this voltage by sinusoidal PWM technique.

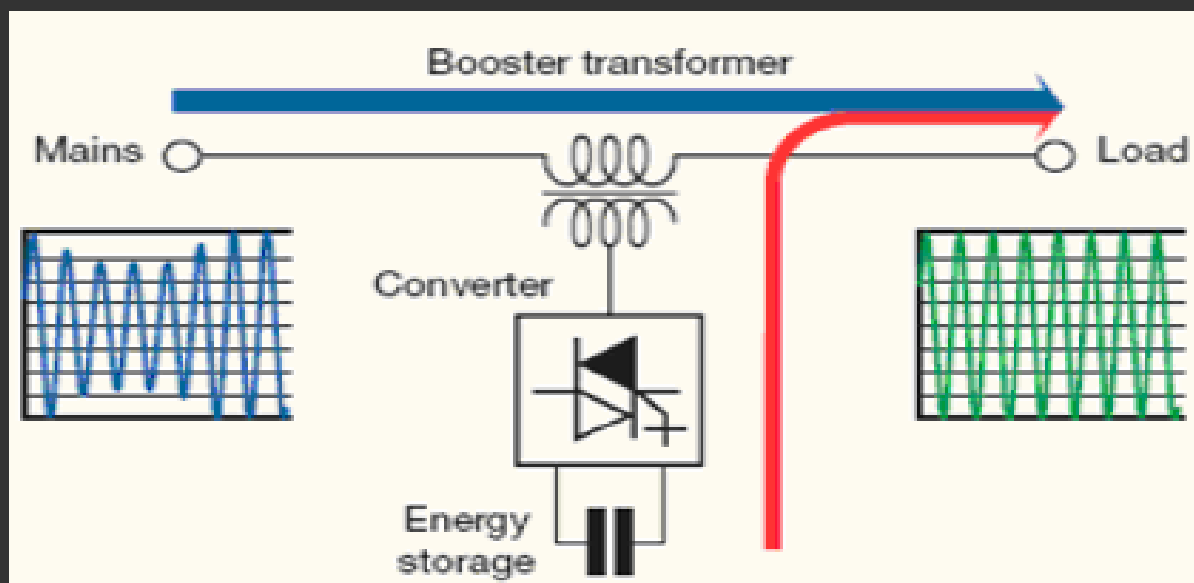

Dynamic Voltage Restorer (DVR)

The DVR is connected in the utility primary distribution feeder as shown in Figure. The DVR will mitigate sensitive equipments.

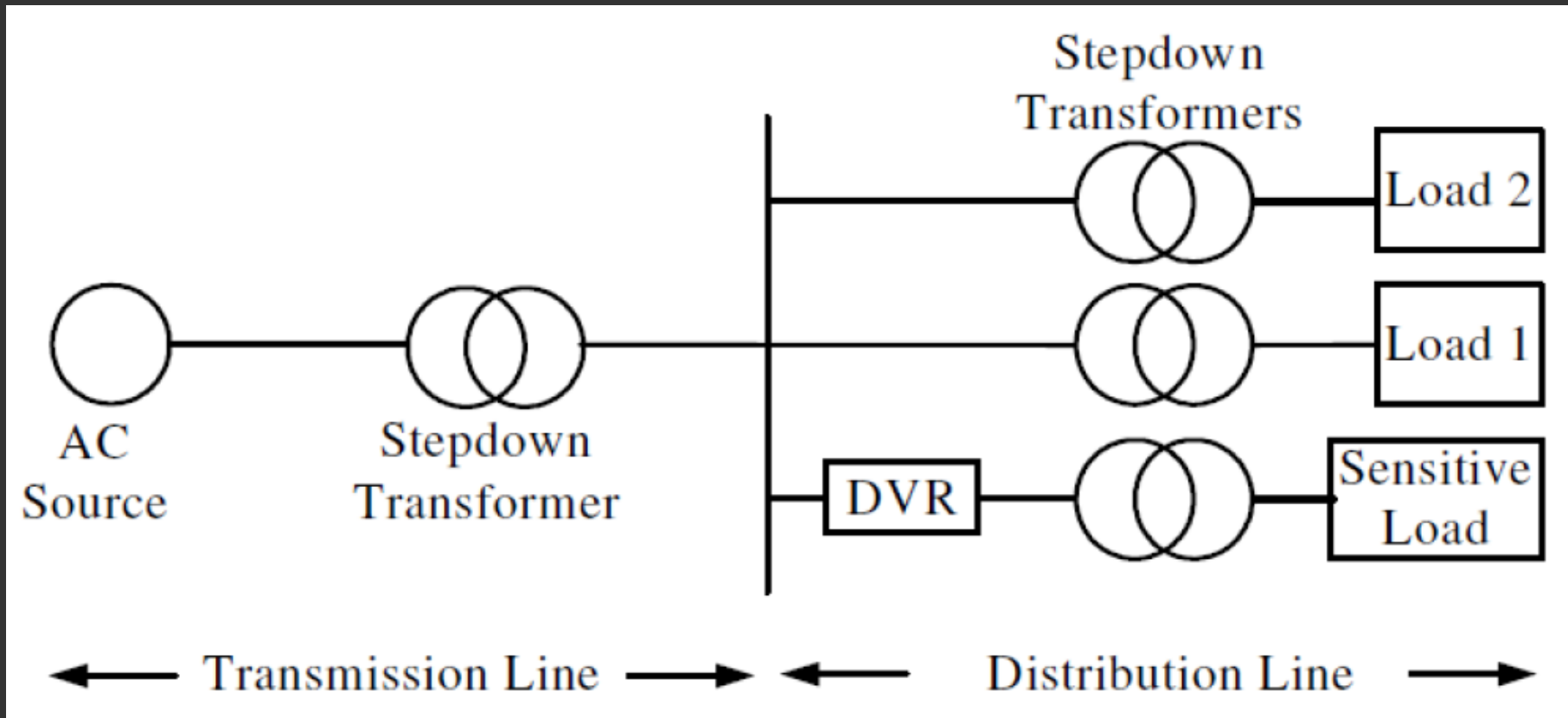

D-STATCOM

- D-STATCOM: is a shunt connected solid state device which is installed at the point of common coupling of the loads so as to control the load side disturbances.
- It is a compensating device based on power electronic technology to be used in the distribution line.

D-STATCOM

- A D-STATCOM is used at the distribution level for the following purposes:
 - Voltage regulation,
 - Correcting of the power factor,
 - Eliminate the total harmonic distortions, voltage,
 - To provide reactive power to the system.

D-STATCOM

DSTATCOM constantly verifies the line waveform with respect to the reference ac signal.

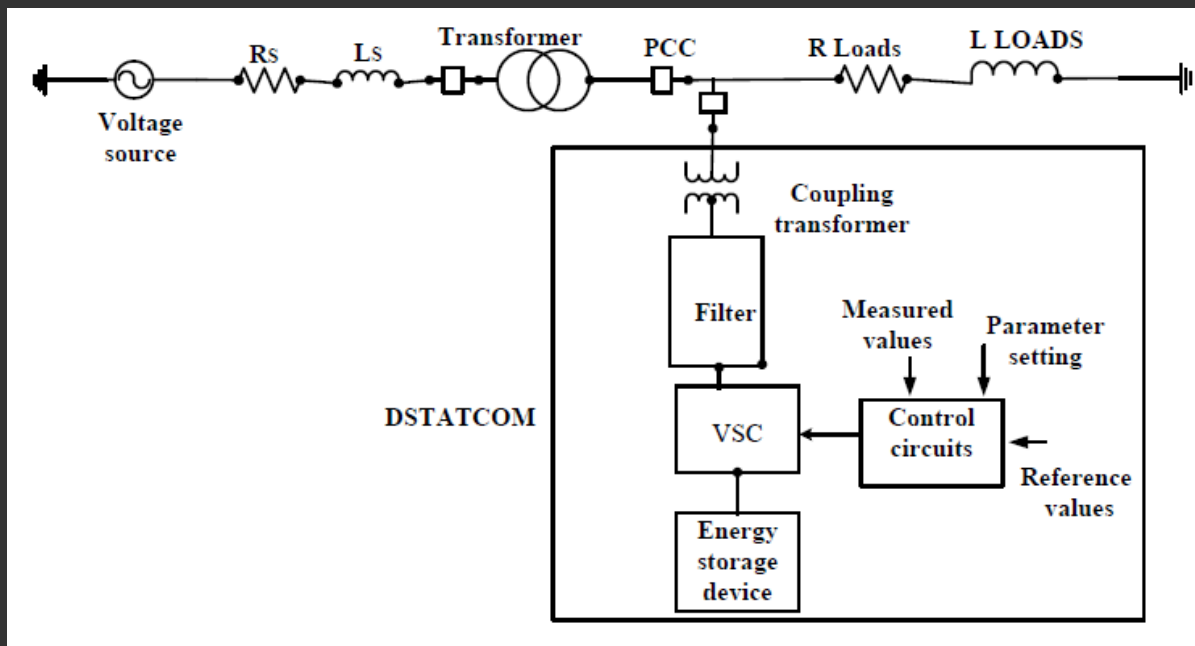

The main components of DSTATCOM are the following:

- Voltage Source Converter
- Energy Storage Device
- L-C Passive Filter
- Coupling Transformer
- Control Block

D-STATCOM

- **Voltage Source Converter:** A VSC converts the DC voltage across storage device into a three phase AC output voltage wave.
- This output voltage is controlled in magnitude and phase angle to generate required leading or lagging reactive power for compensation.

D-STATCOM

- **Energy Storage Device:** DC source is connected in shunt with the DC capacitor. It is the major element that stores the reactive energy and carries the input ripple current.
- **L-C Passive Filter:** eliminate the harmonics
- **Coupling Transformer:** the output voltage of voltage source converter is linked with the AC system via coupling transformer.

- **Control Block:** the main functions of control block are the detection of fault, voltage sag and voltage swell in the system, computation of voltage, generation of trigger pulses to the sinusoidal PWM based DC-AC inverter and closing the trigger pulses when the event has passed.

Wiring and Grounding

- Often the least expensive solution to a power quality problem is proper wiring and grounding, and the more expensive solution is the purchase and installation of the power conditioning equipment described.
- Many times a power quality problem is caused by a loose connection, too small a neutral conductor, incorrect grounding, or a damaged conductor.

Wiring and Grounding

Wiring Solutions

Power quality experts know that wiring solutions to power quality problems involve three basic electrical “S” principles:

1. Separation
2. Selection
3. Shielding

Wiring and Grounding

Wiring Solutions

Separation: Sometimes separation is the easiest and lowest-cost solution. Forcing sensitive and non-sensitive equipment to work together is not a good idea.

For example, when a large motor load starts up, the resulting large inrush current causes a voltage sag on the circuit serving the motor. If there are computers connected on the same circuit, the voltage sag can cause the computers to lose data and freeze. Separation is the answer.

Wiring and Grounding

Wiring Solutions

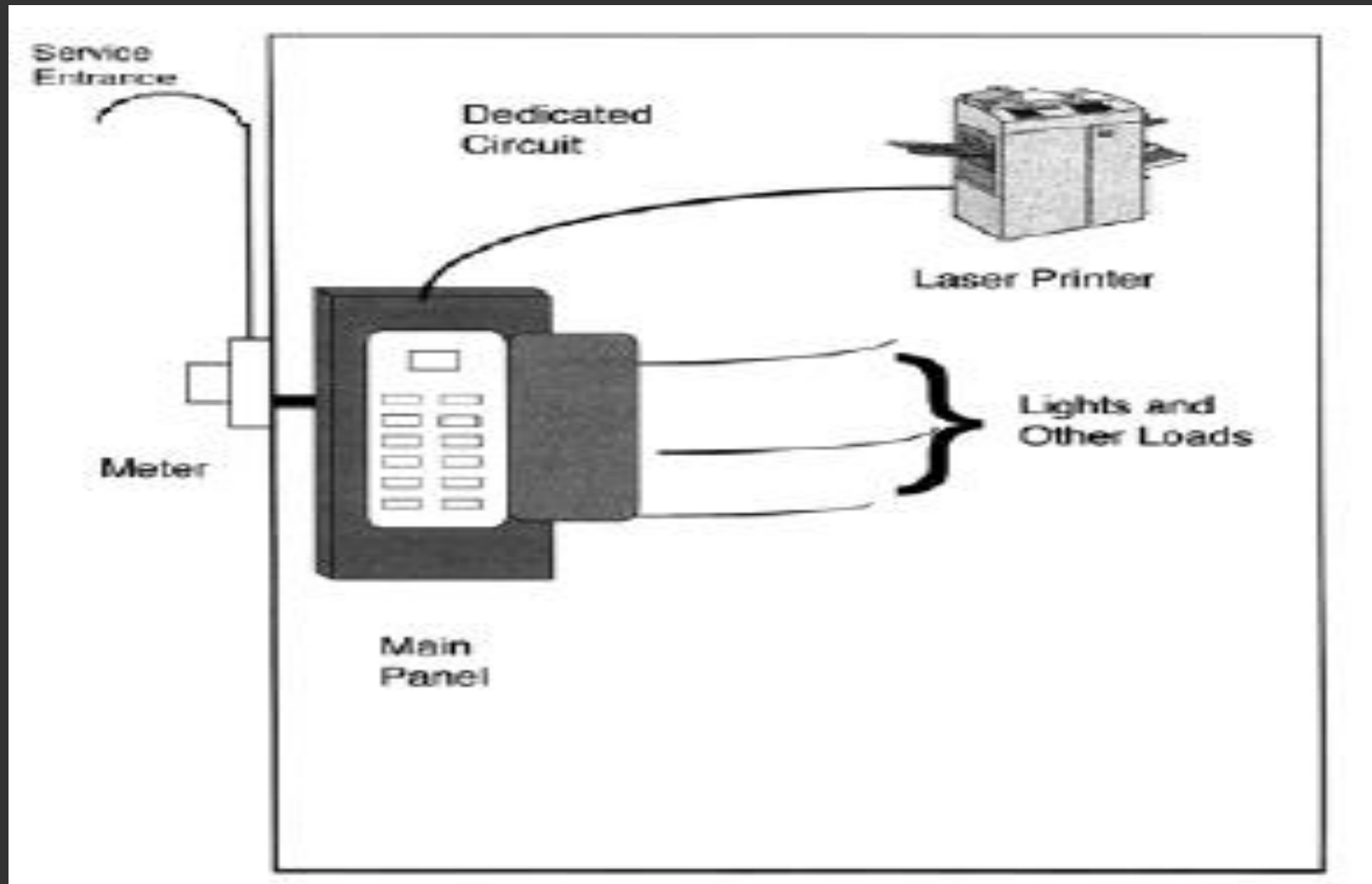

Wiring and Grounding

Wiring Solutions

- Selection of the size and type of wire and cables for both power and data transmission is important in avoiding and solving power quality.
- Select the right wire and cable size to match the capacity of the circuit breaker at the panel board.
- But there are some power quality concerns that affect the selection of the power wire or cable. They include voltage drop and noise.

Wiring and Grounding

Shielding

- Electrical shielding absorbs or reflects electromagnetic interference (EMI) or radio-frequency interference (RFI) noise.
- Shielding of a communications cable consists of a metallic mesh that surrounds the data-carrying conductor.
- It absorbs the noise emitted from the communication line, thus shielding equipment & power lines from receiving unwanted electrical noise.

Grounding

- Proper grounding is critical to the safe and effective operation of all electrical equipment.
- The term *grounding* means connecting an object or electric circuit to ground or earth with an electrical conductor. The *object* is usually a piece of equipment.

Grounding

Grounding has four basic purposes:

1. Protect people from electrical shock and equipment from a short-circuit fault
2. Provide a zero reference point
3. Provide noise control
4. Provide a path for lightning and switching surge faults

Wiring and Grounding

The *NEC* describes the two basic types of safety grounding as

- System grounding and
- equipment grounding.

System grounding is the electrical connection of one of the current carrying conductors of the electrical system to the ground.

Equipment grounding is the electrical connection of all the metal parts that do not carry current of all electrical equipment to the ground.

Wiring and Grounding

Illustration of System and Equipment Grounding

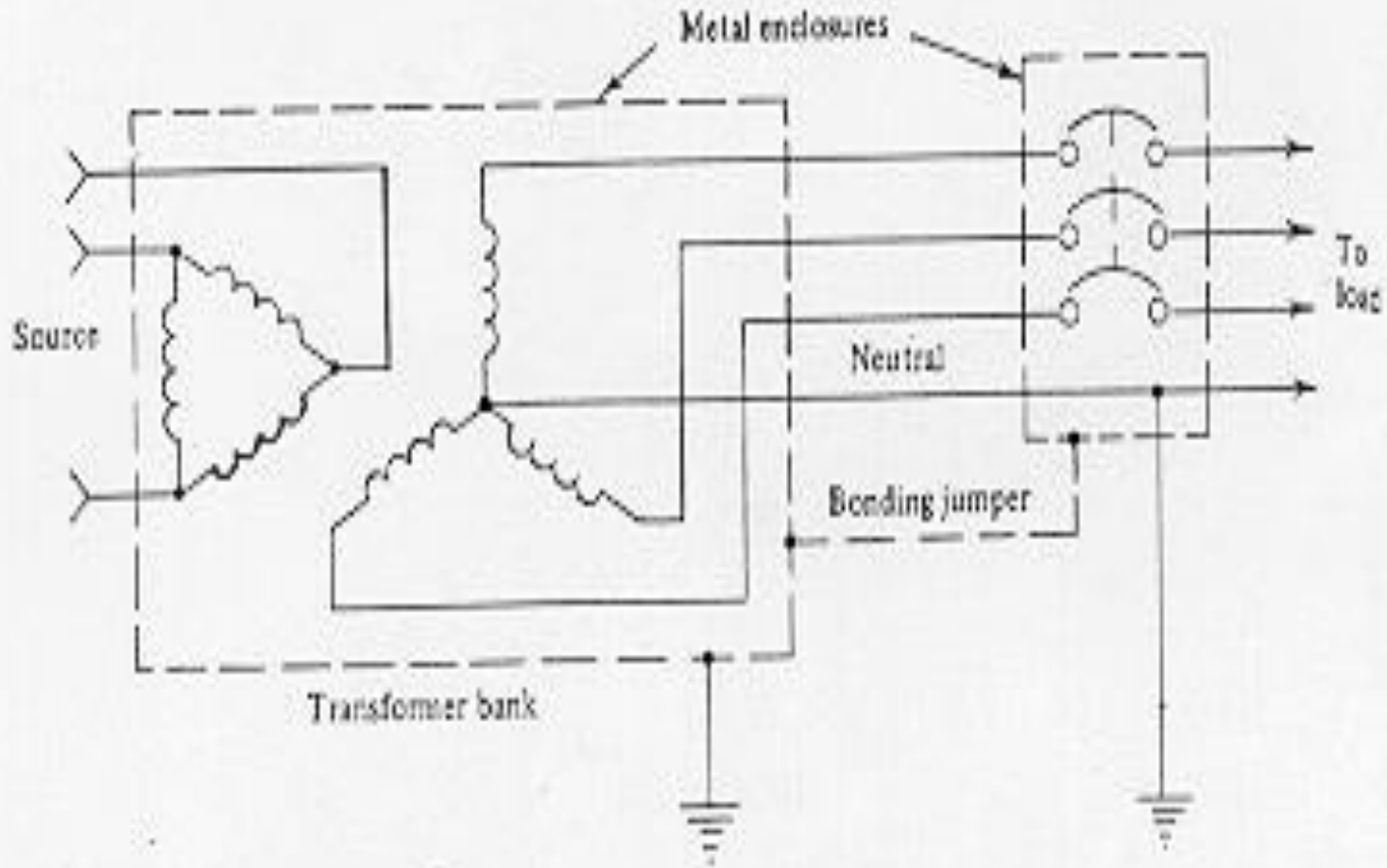

Wiring and Grounding

Illustration of System and Equipment Grounding

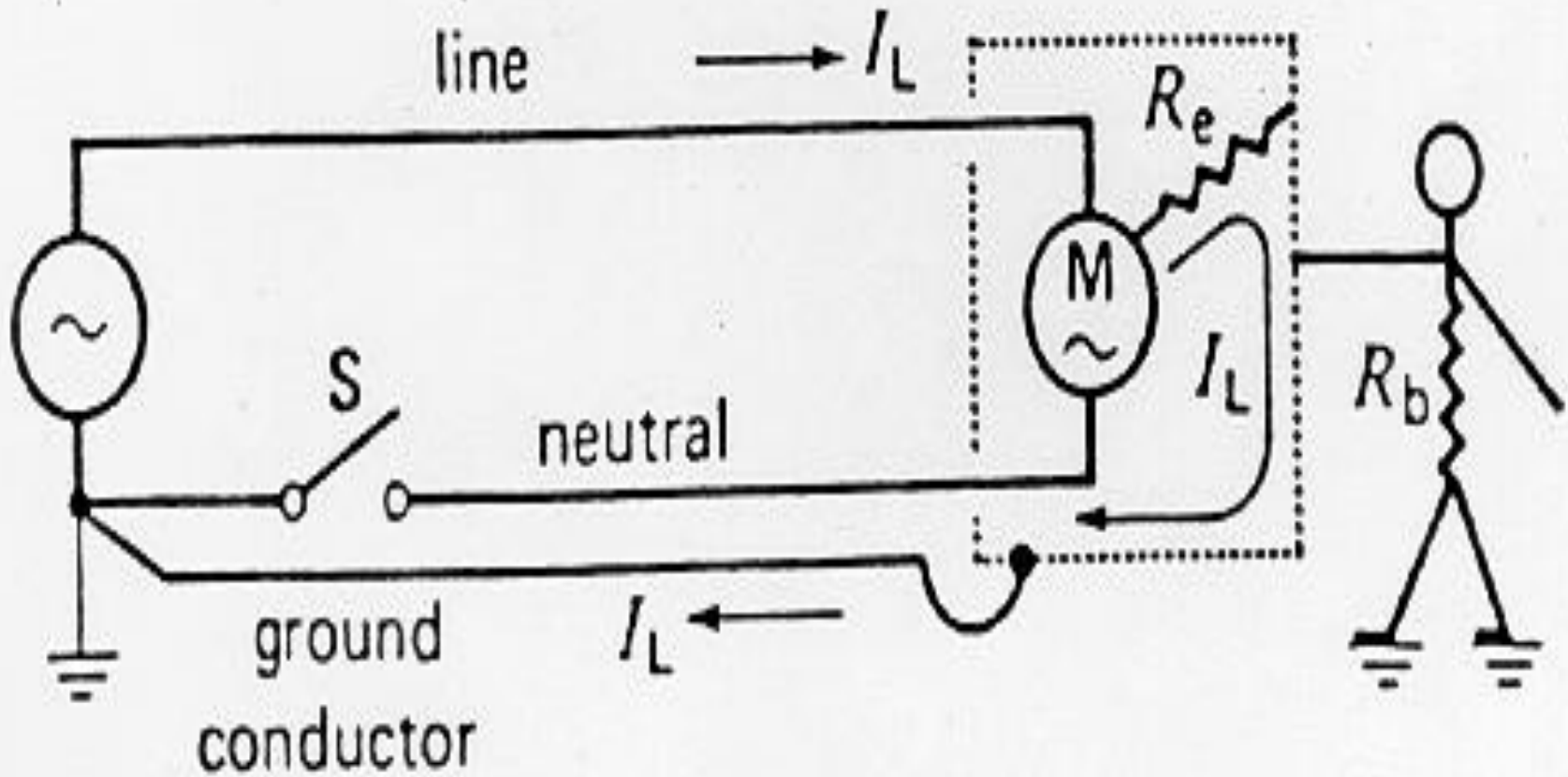

Wiring and Grounding

Illustration of System and Equipment Grounding

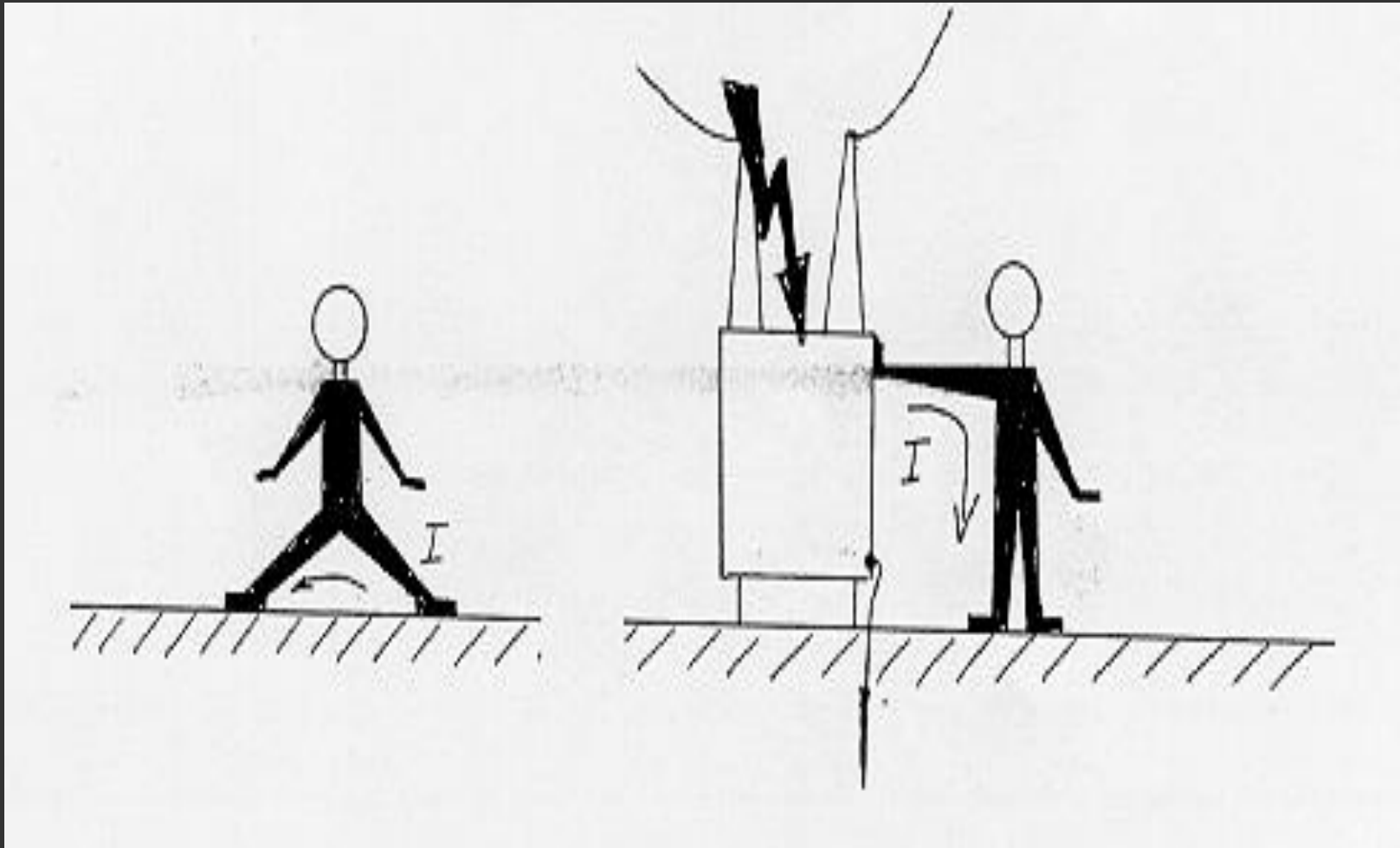

Wiring and Grounding

- Grounding Resistance and Potentail

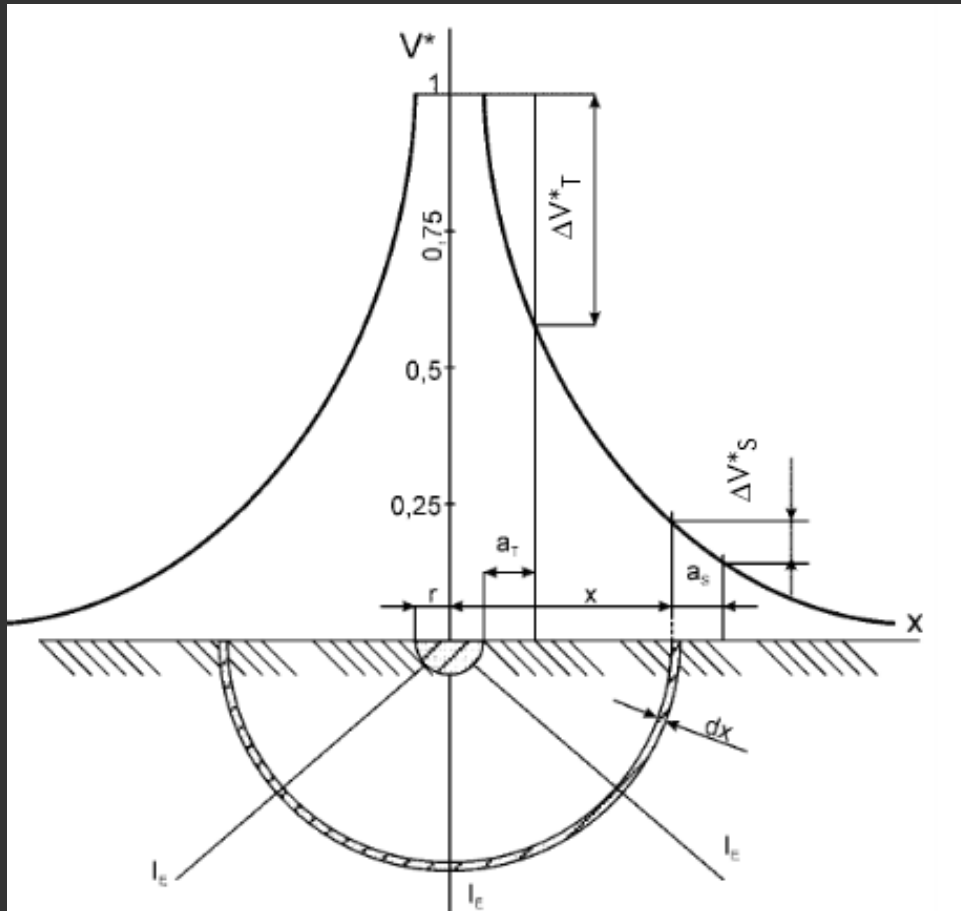

$$dR = \frac{\rho}{2\pi \cdot x^2} dx$$

$$R = \frac{\rho}{2\pi} \int_r^{\infty} \frac{dx}{x^2} = \frac{\rho}{2\pi r}$$

$$V_x = \frac{\rho I_E}{2\pi x}$$

$$V_E = I_E R_E = \frac{\rho I_E}{2\pi r}$$

Wiring and Grounding

- Grounding Resistance
- Step Potential and Touch Potential

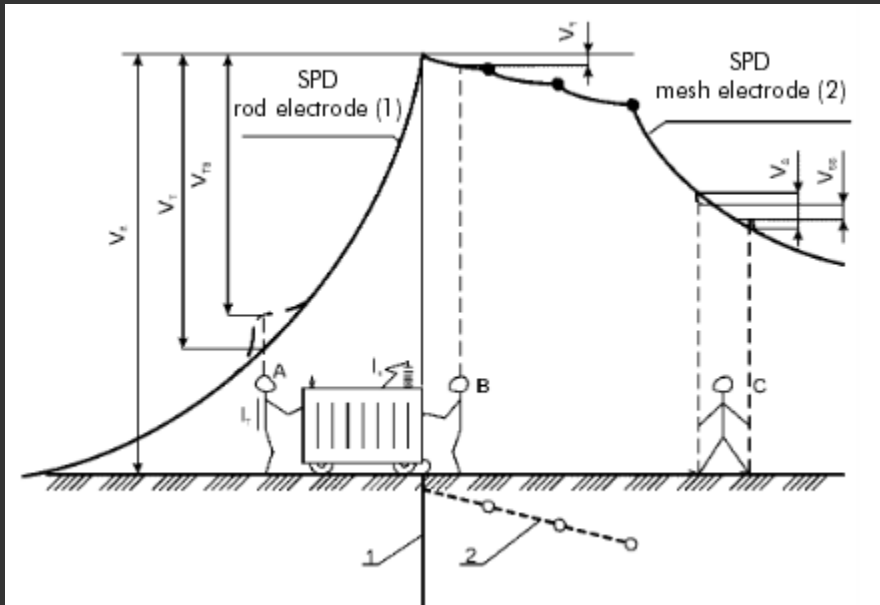

$$V_S = \frac{\rho I_E}{2\pi} \left(\frac{1}{x} - \frac{1}{x + a_s} \right)$$

$$V_T = \frac{\rho I_E}{2\pi} \left(\frac{1}{r} - \frac{1}{r + a_T} \right)$$

Wiring and Grounding

Utility Grounding System

- The utility power grounding system includes the generation, transmission, sub-transmission, and distribution grounding systems.
- Throughout the world, all utilities ground their generators. However, in different parts of the world, utilities ground their transmission and distribution power systems according to the IT, TT, or TN grounding systems.

Grounding

The International Standard IEC 60364-3 classifies the electrical systems with the combination of two letters.

The first letter indicates the relationship of the power system to earth:

- T = direct connection to earth of one point, usually the neutral, in a.c. systems;
- I = all live parts isolated from earth or one point, usually the neutral, connected to earth through an impedance.

Grounding

The second letter indicates the relationship of the exposed-conductive- parts of the installation to earth:

- T = direct electrical connection of exposed-conductive-parts to earth;
- N = direct electrical connection of the exposed-conductive-parts to the earthed point of the power system.

Grounding

Subsequent letters, if any, indicates the arrangement of neutral and protective conductors:

- S = neutral and protective functions provided by separate conductors
- C = neutral and protective functions combined in a conductor (PEN conductor).

Grounding

Earth fault in a TT system: in TT systems the neutral and the exposed-conductive parts are connected to earth electrodes electrically independent; therefore the earth fault current returns to the power supply node through the soil.

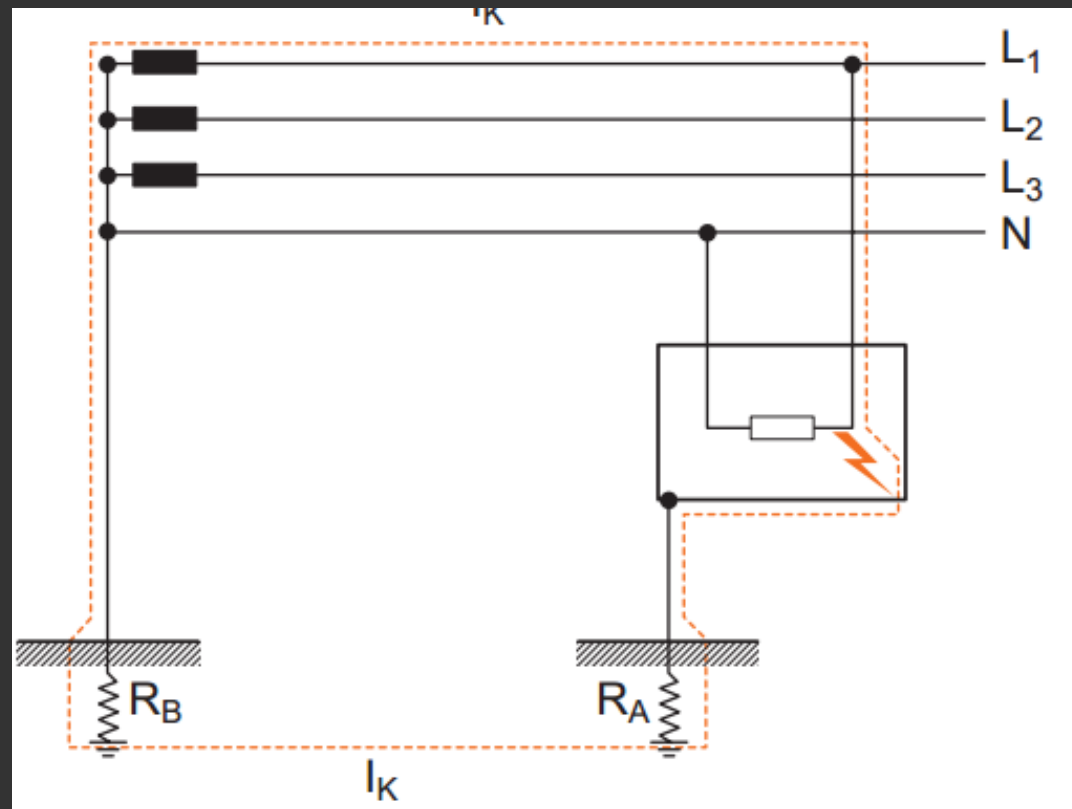

Grounding

TN system: The exposed-conductive-parts are connected to the same earthing arrangement of the neutral.

Grounding

TN electrical systems can be divided into three types based on the fact that the neutral and protective conductors are separate or not:

1. TN-S: the neutral conductor N and the protective conductor PE are separated.

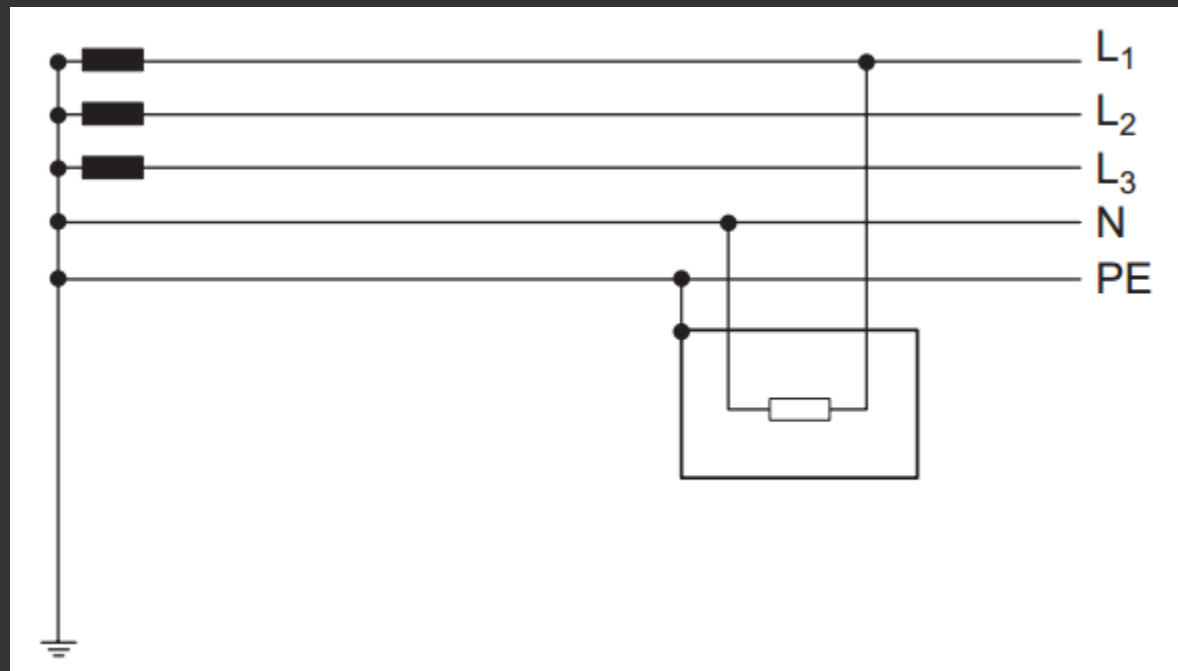

Grounding

2. TN-C: the neutral and protective functions are combined into a single conductor, called PEN

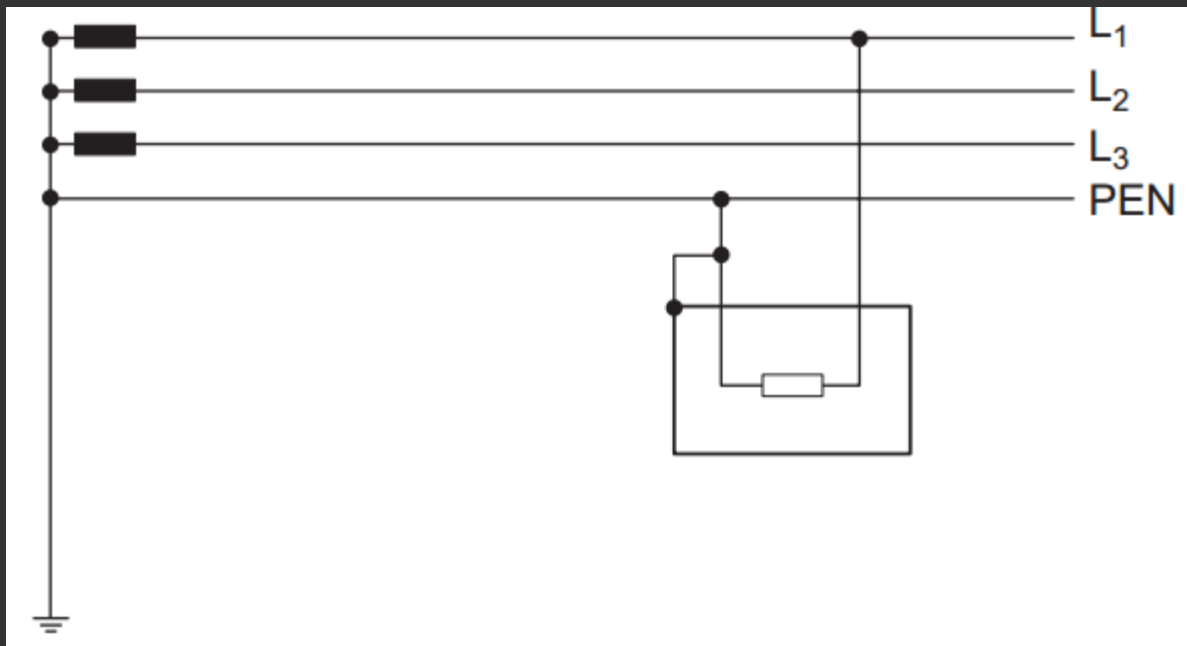

Grounding

3. TN-C-S: the neutral and protective functions are partially combined into a single PEN conductor and partially separated PE + N

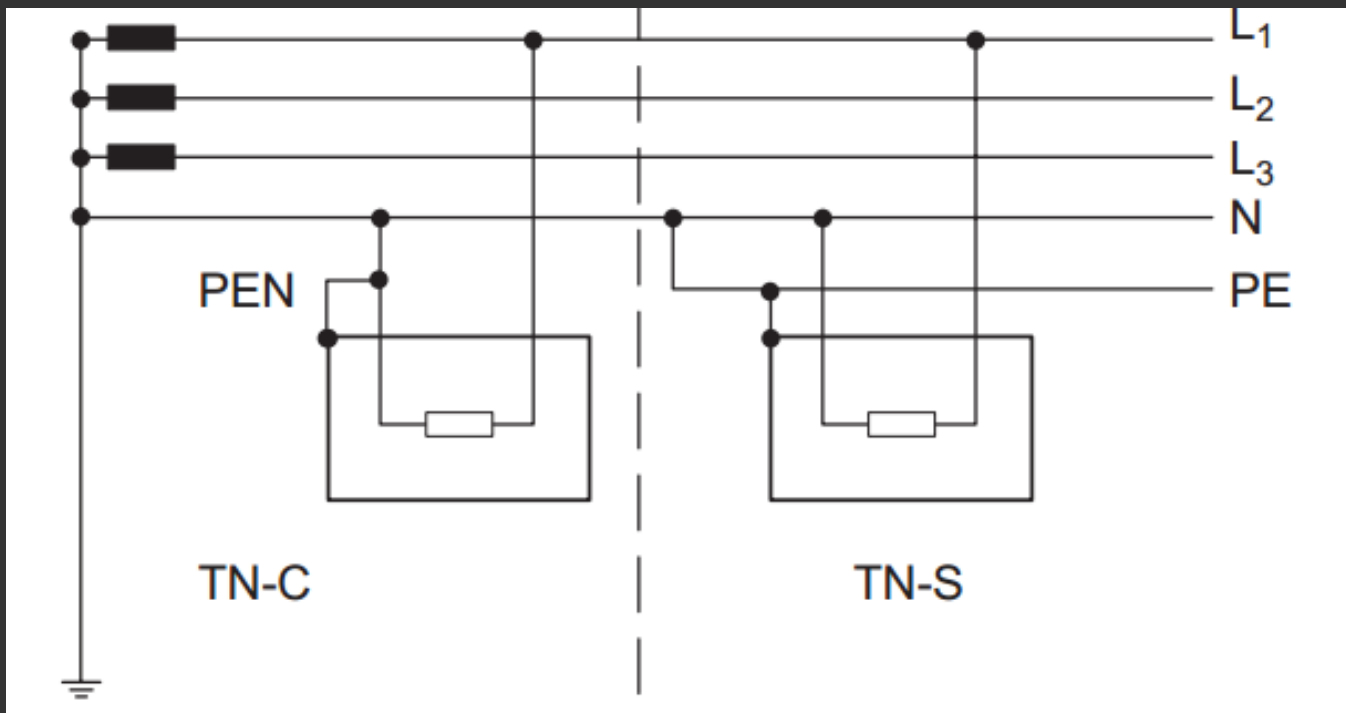

Grounding

In TN systems the earth fault current returns to the power supply node through a direct metal connection (PE or PEN conductor) without practically affecting the earth electrode.

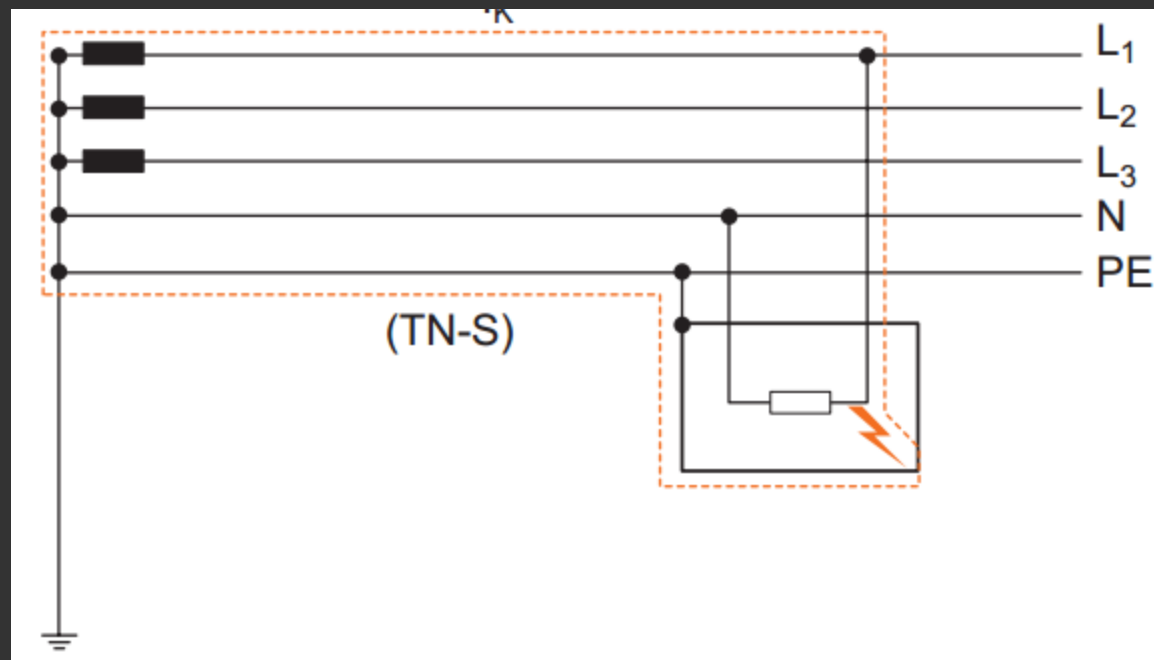

Grounding

IT systems have no active parts directly earthed, but may have live parts connected to earth through high value impedance. All the exposed-conductive-parts, separately or in group, are connected to an independent earth electrode.

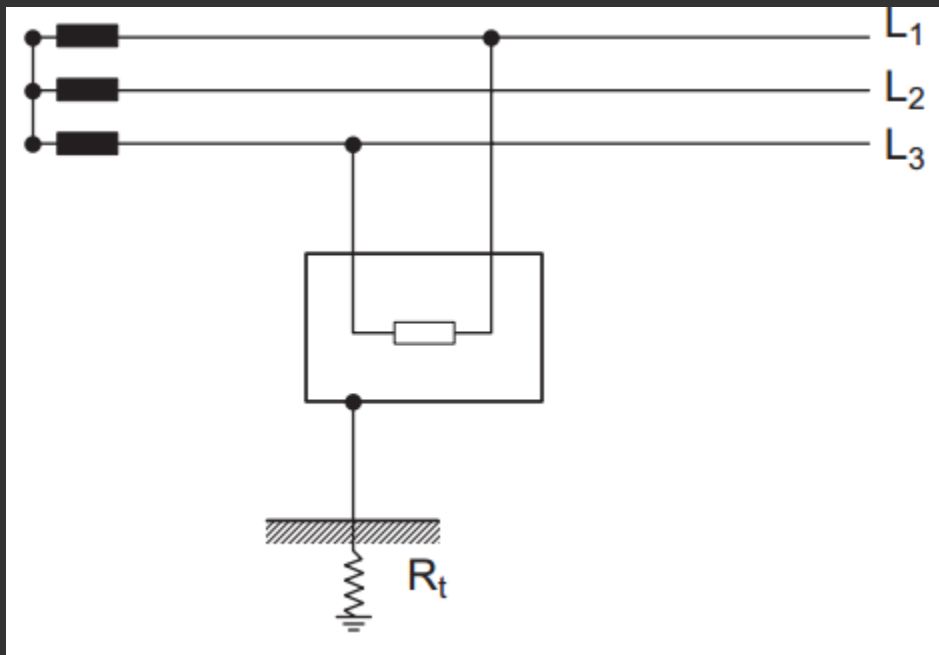

Grounding

Earth fault in a IT system:

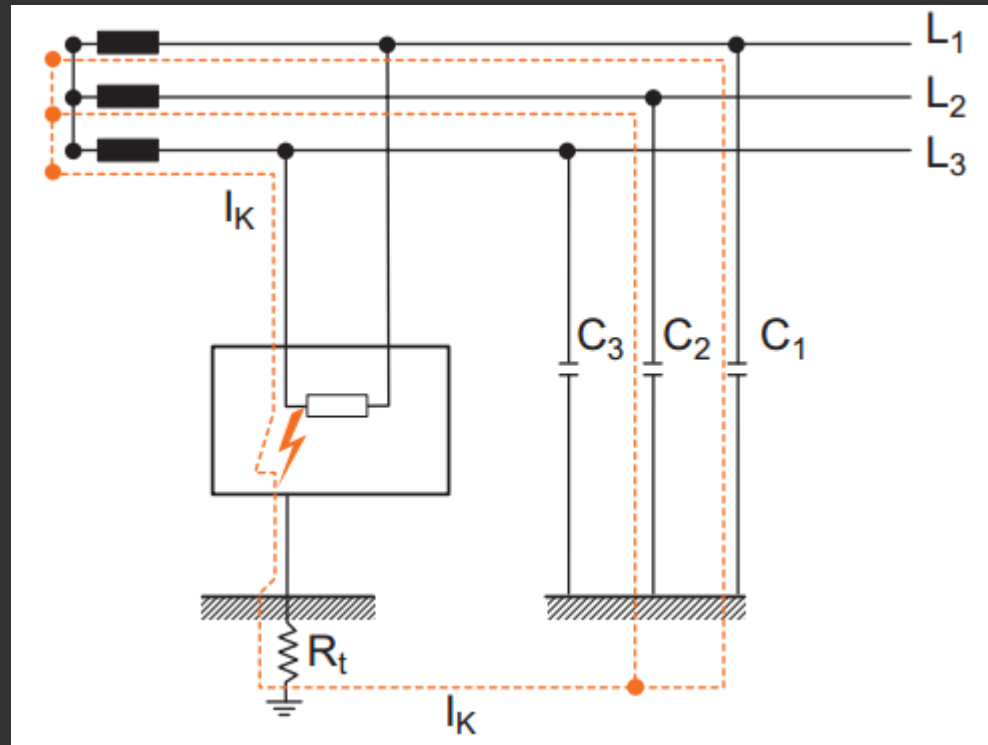

Grounding

Comparison of the systems

Distribution system	Main application	Typical value of the fault currents	Remarks
TT	domestic installations and similar; small industries with LV power supply	10÷100 A	TT distribution systems are used when assuring the distribution of the protective conductor (PE) is impossible and when it is advisable to leave to the user the responsibility for the protection against indirect contact.
TN	industries and big installations with MV power supply	values similar to those of the single-phase fault	TN distribution systems are the systems through which power supply is distributed to users having their own transformer substation; in these cases, the protective conductor can be easily ensured.
IT	chemical and petrochemical industries, i.e. plants for which service continuity is fundamental	$\mu\text{A} \div 2 \text{ A}$ dependent on the size of the installation; in case of double earth fault, the fault current takes values typical of TT or TN systems depending on the connection of the exposed-conductive-parts to earth	This type of system results to be particularly suitable for the cases in which service continuity must be assured since the presence of a first fault does not cause high currents and/or currents dangerous for the people.

Grounding

End-user power system grounding

- Normal grounding practice for residences is to use ground rod or water pipes as a ground.
- The *NEC* requires ground connections to be less than 25Ω , while power quality experts recommend that, to minimize power quality problems, grounds for sensitive electronic equipment should not exceed 5Ω .

Grounding

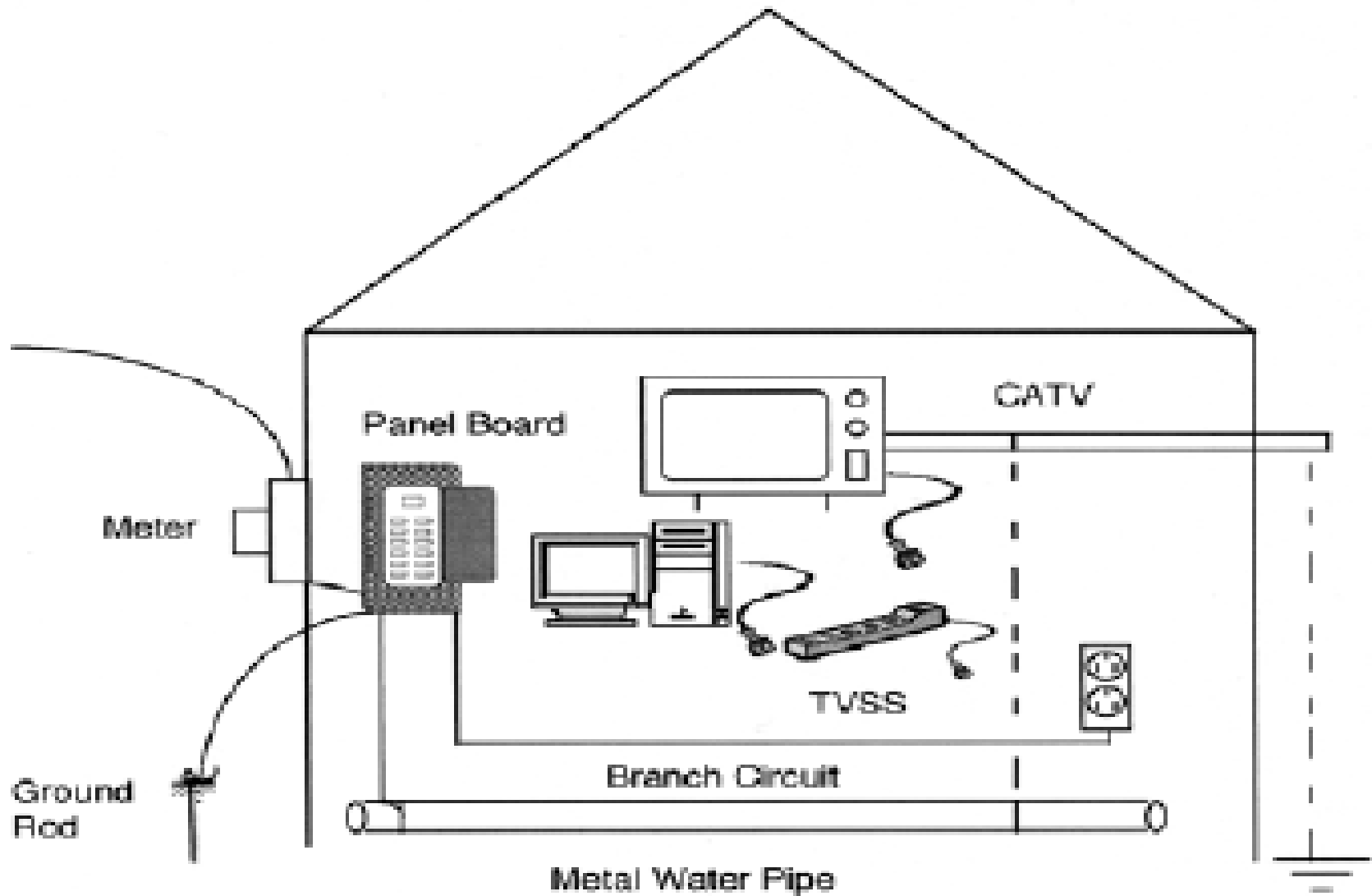

Grounding

Grounding for lightning and static electricity

- Grounding for lightning is an effective way to protect computers and telecommunication systems and other sensitive electronic equipment from being damaged by lightning.
- This static discharge contains a large amount of electrical current that averages about 20,000 A but can be as high as 270,000 A.

Grounding

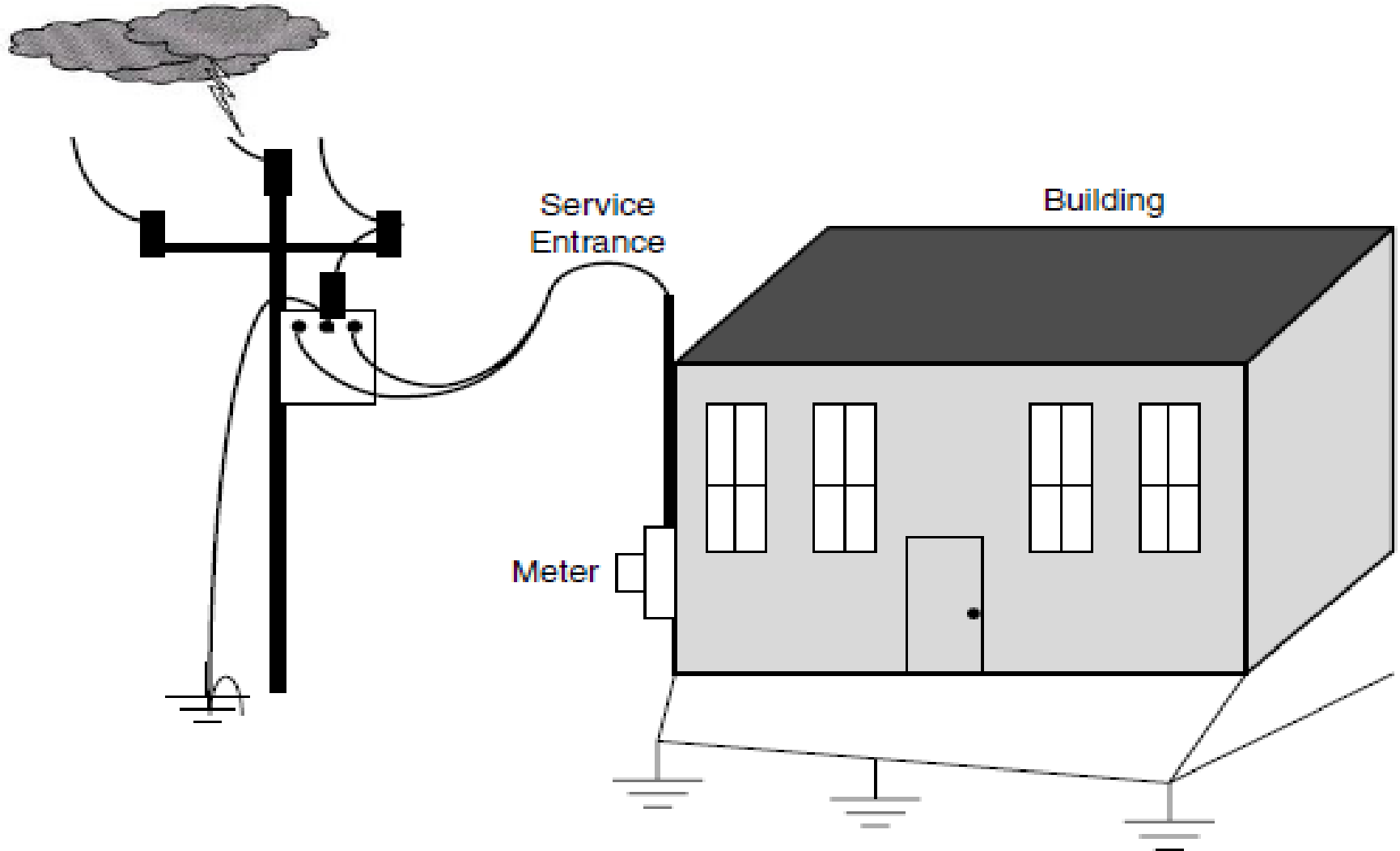

Wiring and Grounding

Grounding for lightning and static electricity

- The best way to prevent lightning from causing damage to equipment is by diverting to ground the high current flow of a lightning stroke.