

PART

VI

Analytical Biochemistry



A selection of preparative ultracentrifuge

The sample tubes of the swinging bucket rotors (*rear*) are hinged so that they swing from the vertical to the horizontal position as the rotor starts spinning, whereas the sample tubes of the other rotors have a fixed angle relative to the rotation axis.

(Courtesy : Beckman Instruments, Inc.)

“There is no higher or lower knowledge but only one flowing out of experimentation”

–*Leonardo da Vinci (LT, 1452–1519)*

CONTENTS

- Observations on Tissues
 - Perfusion
 - Tissues Slices
- Homogenization
- Differential Centrifugation
- Chromatography
 - Paper Chromatography, PPC
 - Thin Layer Chromatography, TLC
 - Ion Exchange Chromatography
- Isotopic Tracer Technique
- Spectrophotometry
- Electrophoresis
- Ultracentrifugation

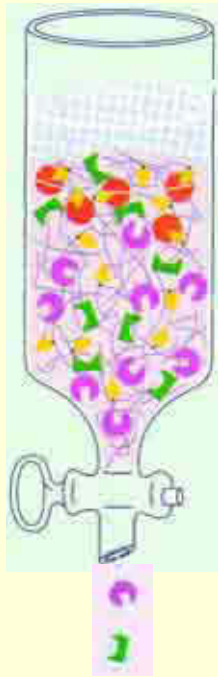

The separation of macromolecules by affinity chromatography

The cutout squares, semicircles, and triangles are schematic representations of ligand-binding sites on macromolecules. Only those ligand-binding sites represented by the orange circles with triangle cutouts specifically bind to the chromatographic matrix-anchored ligands (yellow).

CHAPTER

35

Biochemical Techniques

OBSERVATIONS ON TISSUES

It is often desirable to conduct biochemical studies on an individual organ or individual cells rather than on the body as a whole. But since the growing of single cells in multicelled organisms is not easy and also that after many generations cells from specialized tissues tend to revert to a more primitive type, the biochemist is forced to study either intact organs or preparations from these organs. He can also follow another technique of breaking up the tissues and studying the behaviour of a broken cell preparation.

PERFUSION

This is the simplest way to study intact cells organized in tissues. Here the whole organs is perfused *in situ* or *in vitro* with blood or an isotonic saline solution. The solution is kept recirculating and is also reoxygenated. Arrangements are also made to remove CO_2 from the system. The entire preparation is kept at 37°C by means of a water jacket. In such experiments the tissue itself can be analyzed at the end of perfusion and the changes noted and compared with reference to the composition of the organ before perfusion.

The method, however, suffers from certain *drawbacks* :

- (a) During perfusion experiments, one is sure to lose certain of the regulatory mechanism such as hormonal and nervous control which operate upon the organ in its normal locus.

1028 FUNDAMENTALS OF BIOCHEMISTRY

- (b) Moreover, inferences drawn from such experiments are always those obtained under artificial conditions in which the tissue is operating.

TISSUES SLICES

This technique has been much used in the past for organs such as liver, kidney and brain and also for certain plant tissues like roots and tubers. Here thin slices (approx. 50 μ thick) of tissues are cut. Many of the cells are, of course, damaged but some between 50–70% remain intact. Slicing also offers sufficient surface to the bathing fluid to permit adequate exchange of materials and waste products so that the tissues remain viable for several hours. These slices are then suspended in buffered isotonic saline solutions in airtight vessel to prevent evaporation. Excess O₂ is given by filling the large airspace, present above the liquid, with pure O₂. The vessel is maintained at 37°C and is frequently shaken to promote diffusion. The changes in cellular composition are then studied.

The two serious *drawbacks* with this techniques are as follows :

- (a) The cells are feared to 'die' early during such operations. Henceforth, it is best to conduct the experiments for the shortest possible time but consistent with accuracy in analysis of the various changes.
- (b) Although a fraction of cell membranes is cut in slicing, most cellular constituents still remain contained within the cells.

HOMOGENIZATION

In this the cells are broken up completely so that a homogeneous mixture is obtained which can be adequately oxygenated. The suspension medium can also be changed at will here. The mincing of the material nowadays is done using either a Potter-Elvehjme homogenizer or a blender (see Fig. 35–1). **Potter-Elvehjem homogenizer** consists of a glass tube into which fits a pestle of glass or of polytetrafluoroethylene. The clearance between tube and pestle is between 0.1 and 0.15 mm. The pestle is driven by a motor at 2,000 rpm. A **blender**, on the other hand, consists of a glass vessel fitted with rotating knives. In both the instruments, the tissue is roughly chopped and suspended in a relatively large volume of suitable medium. In order to prevent local heating, the glass tube must be immersed in ice.

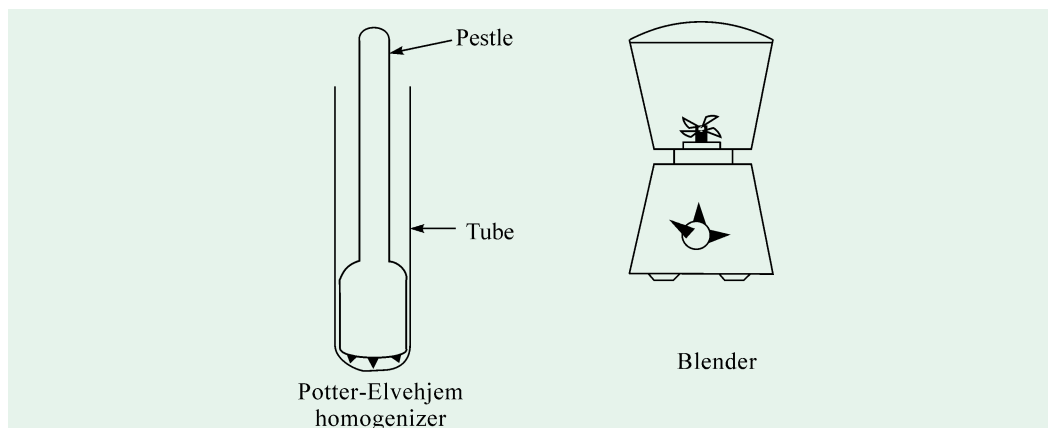

Fig. 35–1. Two common types of mincers

(Redrawn from Datta SP and Ottaway JH, 1965)

After homogenization, the various cell components—nuclei, mitochondria, microsomes etc., can be separated by differential centrifugation (see subsequent section). The various fractions so obtained can be identified by their biochemical composition and, to a limited extent, by histological staining. The intracellular organelles can, however, be observed under electron microscope.

This procedure has proved especially useful in studies concerned with determining the location of chemical processes within the cell.

DIFFERENTIAL CENTRIFUGATION

The centrifugal force exerted on a particle in the solution is expressed in multiples of the force exerted by gravity. *The centrifugal force is proportional to the radius of the centrifugal head and to the square of angular velocity.* Hence, it is more convenient to use relatively small heads rotating at high speeds. Thus, a head of approximately 10 cm diameter rotating at about 40,000 rpm will produce nearly 100,000 g. At such high speeds, the head is run in a vacuum to prevent the heat produced by air friction. The tube containing the homogenate is usually held at an angle to the axis of rotating to keep the path of particles through the solution as short as possible (Fig. 35–2).

The broken cell preparation is loosely referred to as cell-free preparation or '**homogenate**'. Properly prepared, a homogenate is the sum of all the cell components obtained by rupturing the cell membrane.

The homogenate is first diluted and then centrifuged at a low speed to remove nuclei etc. The supernatant liquid is then poured off and centrifuged at a higher speed to remove next fraction. The

Supernatant is that part of the cell material not sedimented by a centrifugal force known to sediment any subcellular structure.

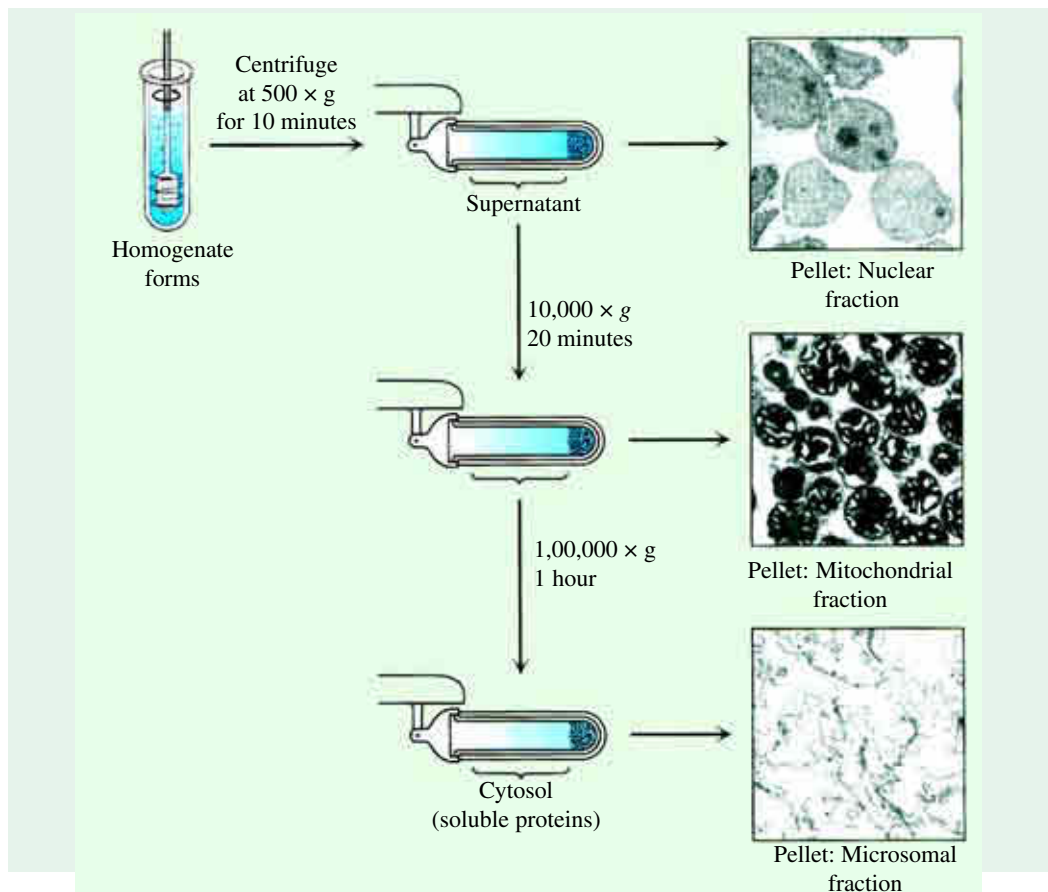

Fig. 35–2. Differential centrifugation

Cells are disrupted in a homogenizer and the resulting mixture, called the homogenate, is centrifuged in a step-by-step fashion of increasing centrifugal force. The denser material will form a pellet at lower centrifugal force than will the less-dense material. The isolated fractions can be used for further purification.

(Photo courtesy : S Fleischer and B Fleischer)

1030 FUNDAMENTALS OF BIOCHEMISTRY

supernatant is then again centrifuged at still a higher speed and fraction separated. The removal of particles of a particular size depends on the magnitude of the field and also on the time for which the field is applied (refer Table 35–1).

Table 35–1. Separation of cell organelles by differential centrifugation

Field*	Time	Structure(s) separated
700 g	10 min	Nuclei, cell membranes
5,000 g	10 min	Mitochondria, lysosomes
57,000 g	60 min	Microsomes, lysosomes
150,000 g	30 min	Ribosomes
Unsedimented		Cell sap, some ribosomes

* These centrifugal fields refer to homogenates in 0.25 M sucrose.

(After Datta SP and Ottaway JH, 1969)

In practice, a mixture of fractions is obtained on single centrifugation. In order to obtain pure fractions, the precipitates have to be recentrifuged many times.

CHROMATOGRAPHY

The term chromatography (*chroma*^G = a colour; *graphein*^G = to write) was originally applied by a Russian chemist, Michael Semonovich Tswett (LT, 1872–1919), in 1906 to a procedure where a mixture of different coloured pigments (chlorophylls and xanthophylls) is separated from each other. He used a column of CaCO₃ to separate the various components of petroleum ether chlorophyll extract into green and yellow zones of pigments. He termed such a preparation as **chromatogram** and the procedure as **chromatography**.

Chromatography may be defined as *the technique of separation of substances according to their partition coefficients below (i.e., their relative solubilities in) two immiscible phases*. In this method, the separation of the components of a mixture is a function of their different affinities for a fixed or *stationary phase* (such as a solid or a liquid) and their differential solubility in a moving or *mobile phase* (such as a liquid or a gas). Separation starts to occur when one component is held more firmly by the stationary phase than the other which tends to move on faster in the mobile phase. Thus, the underlying principle of chromatography is first to adsorb the component of a mixture on an insoluble material and then to differentially remove (or elute) these components one by one with suitable liquid solvents. The adsorbent can be packed into a column (column chromatography) or can be in the form of a sheet (paper chromatography). A third form of chromatography is obtained with columns containing ion exchange resins (*ion exchange chromatography*).

The various chromatographic techniques fall principally under 2 categories : adsorption chromatography and partition chromatography. In **adsorption chromatography**, the stationary phase is a finely divided adsorbent such as alumina or silica gel and the mobile phase can be a gas or more commonly a liquid. **Partition chromatography** involves partition between two liquids rather than adsorption by a solid from a liquid. Here the stationary phase is a liquid which is held on an inert porous supporting liquid. The various forms of chromatography have been represented schematically in Fig. 35–3.

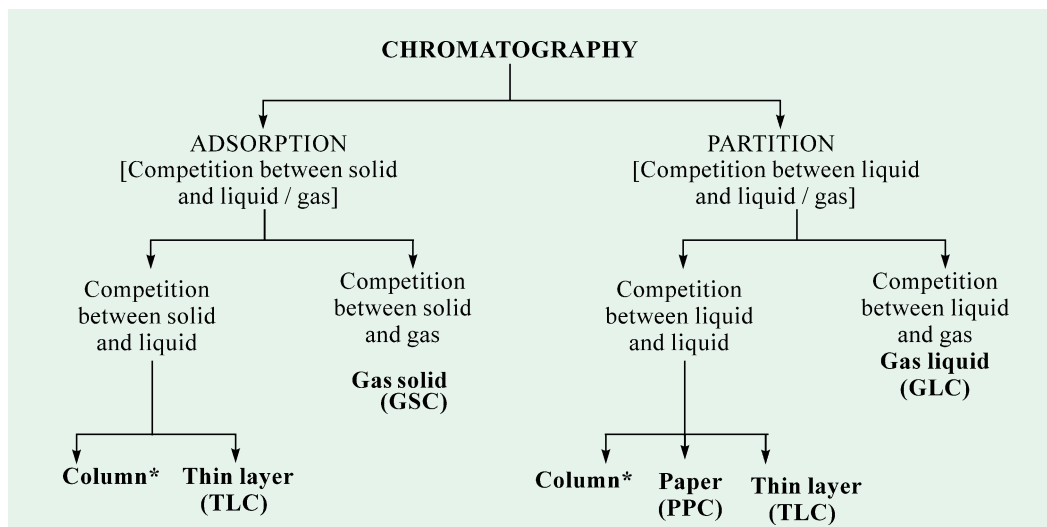

Fig. 35-3. Various forms of chromatography

* Other than gas chromatography.

A few chromatographic techniques are described below.

PAPER CHROMATOGRAPHY, PPC

Two Russian workers, Izmailov and Schraiber (1938) discovered this important technique. *This method is especially useful for the detection and separation of amino acids.* Here the filter paper strips are used to support a stationary water phase while a mobile organic phase moves down the suspended paper strip in a cylinder. Separation is based on a liquid-liquid partition of the compounds. Thus, this is essentially a form of partition chromatography between two liquid phases, although adsorption to the paper may also take place.

In this method, a drop of solution containing a mixture of amino acids (or other compounds) to be separated is applied at a marked point, about 3 cm from one end of a strip of filter paper. Whatman No. 1 paper is most frequently used for this purpose. The chemical composition of Whatman filter paper No. 1 is :

α -cellulose	98 – 99%
β -cellulose	0.3 – 1%
Pentosans	0.4 – 0.8%
Ash	0.07 – 0.1%
Ether soluble matter	0.015 – 0.1%

Whatman No. 3 MM is a thick paper and is best employed for separating large quantities of material; the resolution is, however, inferior to whatman No.1. For a rapid separation, Whatman Nos. 4 and 5 are convenient, although the spots are less well-defined. In all cases, the flow rate is faster in the 'machine direction', which is normally noted on the box containing the papers. The paper may be impregnated with a buffer solution before use or chemically modified by acetylation. Ion exchange papers are also available commercially.

The filter paper is then dried and 'equilibrated' by putting it into an air-tight cylindrical jar which contains an aqueous solution of a solvent. The most widely applicable solvent mixture is *n*-butanol : acetic acid : water (4 : 1 : 5), which is abbreviated as BAW. The end of the filter paper nearest the applied drop is inserted into the solvent mixture at the bottom of the jar, taking care that the marked point of application remains well above the level of the solvent in the jar. The paper is suspended in such a manner so that it hangs freely without touching the sides of the container. Thus, the solvent will *ascend* into the paper and this process is, therefore, termed **ascending chromatography** (Fig. 35-4).

1032 FUNDAMENTALS OF BIOCHEMISTRY

Alternatively, the same end of the filter paper may be put into the solvent mixture contained in a narrow trough mounted near the top of the container. In this case, the solvent will *descend* into the paper and this process is then termed **descending chromatography**. (Fig. 35–5).

Locating the compounds. Strip is removed when the solvent has migrated over most of the available space. The distance to which the solvent has run is marked. In most cases, the completed chromatogram is colourless with no indication of the presence of any compounds. Such a chromatogram is said as '*undeveloped*'. For locating the various compounds, the filter paper strip is first dried, then sprayed with 0.5% ninhydrin in acetone and at last heated for a few minutes at 80 – 100°C. The reaction occurs and the coloured spots appear at the sites of the amino acids. Such a chromatogram is now called '*developed*'.

However, if the solution chromatographed is one derived from a tracer experiment, the compounds will be radioactive and can be located either by using a Geiger counter or by placing the paper strip against a sheet of x-ray film. The β -rays from the radioactive compounds will expose the film. The negative, on developing, will show dark spots at the site of radioactive compounds. This method has been used most successfully in tracing the carbon pathway in photosynthesis.

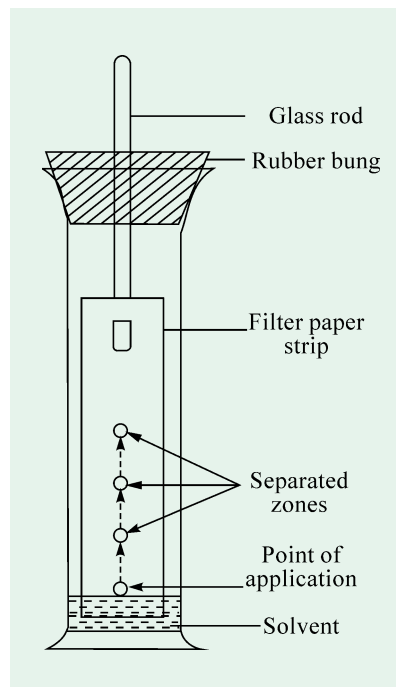

Fig. 35–4. One-dimensional paper chromatography (Ascending type)

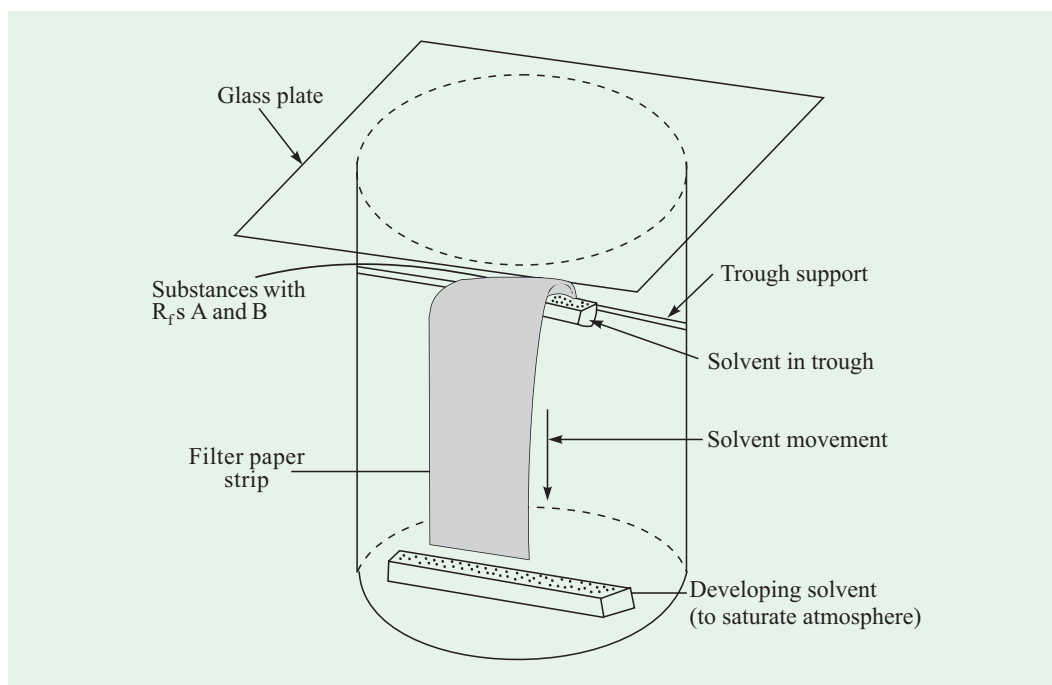

Fig. 35–5. One-dimensional paper chromatography (Descending type)

In paper chromatography, the stationary cellulose phase is more polar than the mobile organic phase. Amino acids with large nonpolar side chains (leucine, isoleucine, phenylalanine, tryptophan, valine, methionine, tyrosine) migrate farther in *n*-butanol : acetic acid : water (4 : 1 : 5) than those with shorter nonpolar side chains (proline, alanine, glycine) or with polar side chains (threonine, glutamic acid, serine, arginine, aspartic acid, histidine, lysine, cysteine). This reflects the greater relative solubility of polar molecules in the hydrophilic stationary phase and on nonpolar molecules in organic solvents.

Identifying the compounds. In chromatography, the distance travelled by a particular component of a mixture (or solute) is used to identify it. The ratio of the distance travelled by a component (*i.e.*, amino acid) to that travelled by the solvent front, both measured from the marked point of application of the mixture, is called the **resolution front** (R_f) value for that component. Thus,

$$R_f = \frac{\text{Distance from origin run by the compound}}{\text{Distance from origin run by the solvent}}$$

Table 35–2. R_f values of amino acids in various solvents

S. N.	Amino Acid	Phenol : Water	Collidine : Water	Butanol : Acetic Acid : Water, BAW
1.	Glycine	0.36	0.26	0.26
2.	Alanine	0.55	0.32	0.38
3.	Valine	0.72	0.43	0.60
4.	Leucine	0.80	0.55	0.73
5.	Isoleucine	0.83	0.53	0.72
6.	Serine	0.30	0.30	0.27
7.	Threonine	0.43	0.32	0.35
8.	Cystine	0.24	0.11	0.08
9.	Methionine	0.74	0.53	0.55
10.	Proline	0.88	0.34	0.43
11.	Aspartic acid	0.22	0.23	0.24
12.	Glutamic acid	0.23	0.27	0.30
13.	Phenylalanine	0.83	0.54	0.68
14.	Tyrosine	0.55	0.59	0.45
15.	Tryptophan	0.71	0.59	0.50
16.	Histidine	0.62	0.30	0.20
17.	Arginine	0.54	0.17	0.20
18.	Lysine	0.41	0.11	0.14

(Adapted from Fruton JS and Simmonds S, 1958)

The R_f value for a given compound varies with the type of solvent used (refer Table 35–2, for amino acids). *Similar R_f values, however, do not necessarily mean the identical compounds as different compounds may have identical R_f values in a given solvent system.* Henceforth, different solvent systems are used to identify the compounds by chromatography. It is preferable to chromatograph known amino acid standards along with the unknown mixture so that the R_f values be easily compared and the amino acids be safely identified.

Quantitation of the compounds. Quantitative analysis of the amino acids may be accomplished by cutting out each spot, eluting (or removing) the compound with a suitable reagent and performing a calorimetric (ninhydrin) or chemical (nitrogen) analysis. Alternatively, the filter paper strip may be sprayed with ninhydrin and heated so that the coloured spots indicating the location of amino acids may develop. The colour densities of these spots may be measured with a recording transmittance or reflectance photometer device.

1034 FUNDAMENTALS OF BIOCHEMISTRY

The chromatographic technique described above allows *vertical* separation of amino acid and is termed as **one-dimensional paper chromatography**.

For obtaining better separation of components and to improve their quantitation, a **two-dimensional paper chromatography** is applied (Fig. 35–6). In this technique, a square sheet of filter paper, rather than a strip is taken. The test sample is applied to the upper left corner and chromatographed for some hours with one solvent mixture (*e.g.*, *n*-butanol : acetic acid : water). After drying to remove this solvent, the paper is turned through 90° and chromatographed in a second solvent mixture (*e.g.*, collidine : water). This technique thus allows both *vertical* and *horizontal* separation of the amino acids.

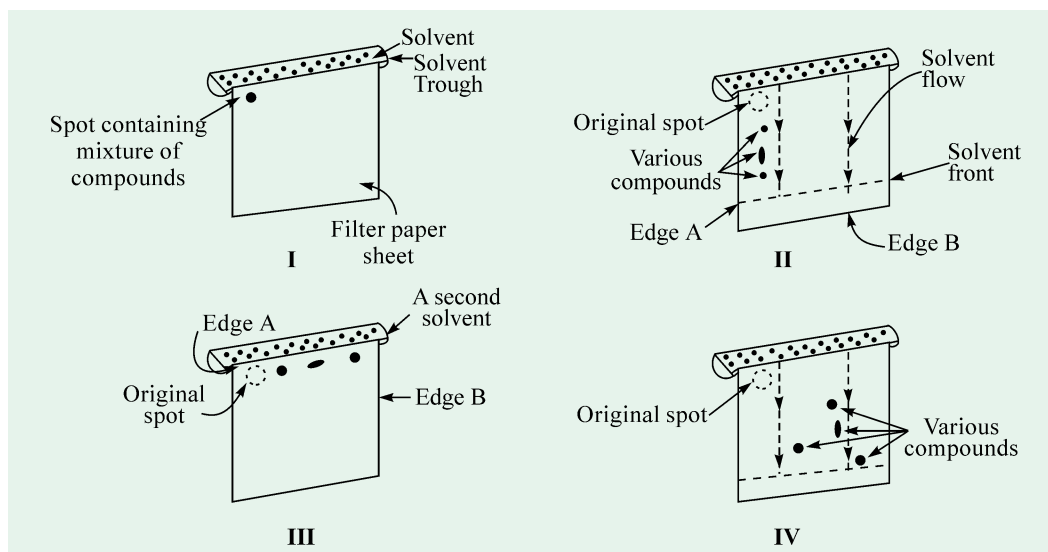

Fig. 35–6. Two dimensional (or ‘2-D’) paper chromatography
(Descending type)

Forces in operation. The movement of the solute molecules on the chromatogram depends on the net result of a number of forces operating in the system. These forces are of 2 types : propelling and retarding.

(a) *Propelling forces* – These include the capillary force and the solubility force of the solvent. The Whatman paper is made up of numerous fibrils which are placed very close to each other, thus forming a network of capillaries. The solute rises through these capillaries as a result of **capillary force**. *The smaller the bore of the capillaries, the greater is the height to which the solute rises.*

The **solubility forces of the solvent** refers to the capacity of the solvent to dissolve the solute. The rise of solute also depends on its solubility in the solvent being used. *The greater the solubility of the solute in the solvent, the greater is the height to which it rises in the chromatogram.*

(b) *Retarding forces* – Concurrent with the forces of propulsion, certain retarding forces also operate in the system which try to drag the solute molecules from moving in either direction. These retarding forces include the gravitational force and the partition force. Under the ascending chromatography, the solute molecules have to move against the **gravitational force** which acts from below and tends to retard the movement of solute molecules in the upward direction. Under the descending chromatography, obviously, the gravitational force does not figure as a retarding force, rather it assists in propulsion and, henceforth, acts as a propelling force.

The **partition force** refers to the force between liquid and liquid molecules. The interstices between the fibrils on the Whatman paper are occupied by the solvent molecules and the solute molecules, for their movement, have to displace them. Should the spaces not been filled with the solvent molecules, the

movement of the solute molecules through them would have been much more facilitated.

Thus, the movement of the solute molecules on the Whatman paper in either direction is the net result of the interaction between various forces of propulsion and retardation. Movement of the solute molecules is exhibited only when the propelling forces exceed the retarding forces in magnitude.

THIN LAYER CHROMATOGRAPHY, TLC

Thin layer chromatography is adsorption chromatography performed on open layers of adsorbent materials supported on glassplates. *This technique combines many of the advantages of paper chromatography with those of column chromatography.* Here a thin uniform film of adsorbent (like silica gel or alumina powder) containing a binding medium (like calcium sulfate) is spread onto a glass plate. The thin layer is allowed to dry at room temperature and is then activated by heating in an oven between 100° to 250°C. The activated plate is then placed flat and samples spotted with micropipettes carefully on the surface of the thin layer. After the solvent has evaporated, the plates are placed vertically in a glass tank containing a suitable solvent. Within a short time (5 to 30) minutes), the various components get separated by the solvent rising through the thin layer. The glass plate is then taken out from the tank, allowed to dry and then the spots are detected by spraying the plate with a variety of reagents.

Superiority of TLC – The superiority of TLC over paper chromatography lies in the following facts :

- (a) Because of the inorganic nature of the adsorbent (supporting medium), concentrated sulfuric acid spray followed by heating may be used to develop (or locate substances on) the chromatogram by charring and rendering visible any spots of organic nature.
- (b) Moreover, amino acid mixtures, which require 18 hours for separation on paper, require as little as 3 hours using cellulose TLC.
- (c) The advantage of this technique also lies in the choice of the adsorbents which allow separation not possible on paper.

Thus, *the speed, efficiency and sensitivity of TLC has made this technique most valuable to the biochemists.* Lipids including sterols may be neatly separated by TLC on alumina. Also after localization of these substances on the glass plate with reagents, selected spots of the plate's surface may be scrapped off and the compounds isolated by extraction of the alumina powder with suitable solvents.

ION EXCHANGE CHROMATOGRAPHY

Ion exchange chromatography is in wide use for the separation of amino acids. It employs synthetic resins such as a strongly acidic cation exchanger, **Dowex-50** and a strongly basic anion exchanger, **Dowex-1**. The former is a polystyrene sulfonic acid and the latter a polystyrene quaternary ammonium salt.

Two common cellulose derivatives, carboxymethyl cellulose (CMC) and diethylaminoethyl cellulose (DEAE) are successfully used in protein purification. CMC is a cationic derivative and DEAE, an anionic derivative. An even more versatile substance for the separation of protein is a cross-linked dextran called **sephadex**. When packed in a column and equilibrated with buffer, the polysaccharide acts as a molecular sieve for protein molecules. Five grades of sephadex are available. Sephadex G-25 beads retain molecules with molecular weights up to 5,000. In other words, the 'exclusion limit' of G-25, is 5,000. The exclusion limits of the remaining four grades, G-50, G75, G-100 and G-200-- are 10,000, 50,000, 100,000 and 200,000 respectively.

Thus, electrostatic attraction of oppositely charged ions on a polyelectrolyte surface forms the basis of ion exchange chromatography. In principle, the ionized groups of the ion exchange materials form salts with ions of opposite charge and they exchange these ions for others when the relative salt concentrations in the solution are varied. Ion exchange chromatography is especially useful in separation

1036 FUNDAMENTALS OF BIOCHEMISTRY

and purification of nucleotides owing to their low molecular weights and the presence of ionizable groups.

In practice, the protein mixture is passed through a column of the modified cellulose contained in a glass tube and allowed to become attached to the column material. Increasing salt concentration and/or buffers of varying pH values are then passed through the column. Proteins will be washed off the column at different times depending on their molecular structure, net charge and side group. The essential process is depicted in Fig. 35-7.

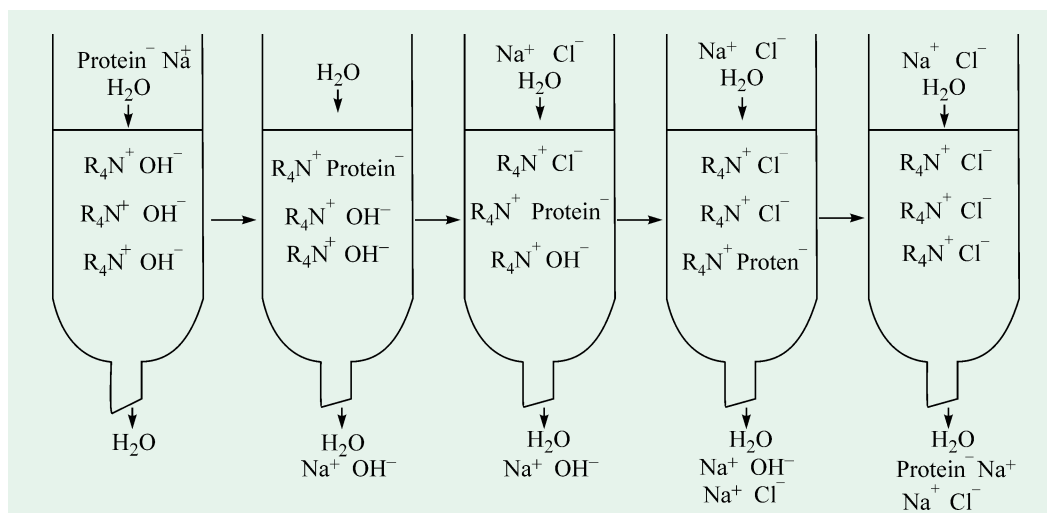

Fig. 35-7. Ion exchange chromatography

The various processes occurring as protein is absorbed by and eluted from an ion exchange column are illustrated here. The ion exchange material is assumed to be an insoluble polymer having free substituted amine groups.

(Adapted from Fariley JL and Kilgour GL, 1966)

ISOTOPIC TRACER TECHNIQUE

In the studies of metabolic transformation of a particular substance, the primary objective of the biochemists remains to observe the fate of that substance *in vivo* under experimental conditions which cause minimum physiological disturbance to the test organism. Isotopic tracer technique has been most successfully used for such type of studies. Here one or more of the atoms in metabolite under study is "labelled" by means of one of the rare or artificially produced isotopes and its path followed while frequently testing the intermediary compounds at intervals.

The nucleus of each elementary species is characterized by an **atomic number**, which is equal to the number of protons and is also equal to the number of electrons around the nucleus when the atom exists in an electrically neutral state. All atoms of a particular element have the same atomic number. Each nucleus is also characterized by what is called as the **mass number** and which is equal to the total number of protons and neutrons contained therein. The difference between the two numbers is obviously the number of neutrons contained in the nucleus. *The various isotopes of an element have the same atomic number but different atomic mass.* Conventionally, the atomic number is written as subscript that precedes the elementary symbol and the mass number as superscript that follows the symbol. For example, nitrogen (atomic number 7) is found in nature both with a mass of 14 (designated as ${}^7N^{14}$) and with a mass of 15 (designated as ${}^7N^{15}$). Similarly, carbon with atomic number 6 has different mass number of 11, 12, 13 and 14 and the various isotopes are accordingly written as ${}^6C^{11}$, ${}^6C^{12}$, ${}^6C^{13}$ and ${}^6C^{14}$. Being implicit in the symbol, the atomic number is often not written. Thus, the two common isotopes of carbon are simply written as C^{12} and C^{14} .

Isotopes are of 2 types – stable and radioactive. The *stable isotopes* are those whose nuclei do not undergo spontaneous decomposition. N^{14} , N^{15} , O^{18} , C^{13} , S^{33} and S^{34} belong to this category. Atoms whose nuclei decompose spontaneously with the emission of radiations are termed *radioactive isotopes*. C^{14} , S^{35} , P^{32} and H^3 belong to this group.

Stable Isotopes. The stable isotopes of biological importance are available in enriched concentrations. The important ones are H^2 , N^{15} , C^{13} and O^{18} . These atoms occur in nature in the following relative abundance :

$$\begin{aligned} H^1/H^2 &= 99.98/0.02 \\ N^{14}/N^{15} &= 99.63/0.37 \\ C^{12}/C^{13} &= 98.09/1.10 \\ O^{16}/O^{18} &= 99.80/0.20 \end{aligned}$$

The concentration of these stable isotopes, 0.37% of N^{15} for example, is called the *normal abundance*. The concentration of a heavy isotope is usually measured as *atom per cent excess i.e.*, the amount in per cent by which the isotope exceeds its normal abundance. As an illustration, if a sample of nitrogen gas contains 3% N^{15} (and 97% N^{14}), the concentration of N^{15} in this sample is said to be (3.0–0.37) or 2.63 atom per cent excess.

The stable isotopes are measured quantitatively with a **mass spectrometer**. Devised by Aston in 1919, this instrument has now been greatly improved. In fact, this apparatus converts the uncharged atoms or molecules into positively charged ions (cations). These are then accelerated into the field of a powerful magnet. In the magnetic field, the ions will be deflected to an extent corresponding to their mass. *The path of the heaviest particles is bent least and that of the lightest particles is bent most.* The relative amounts of the ions of different mass is then determined by collecting them on a plate and measuring the current produced.

This technique for measuring stable isotopes is less sensitive and more tedious than that for measuring radioactive isotopes. However, since no useful radioactive isotopes of oxygen and nitrogen exist, the mass spectrometer remains an essential tool for studies involving these elements.

Table 35–3. Properties of useful radioactive isotopes

S.N.	Isotope	Half Life*	Type of Radiation	Energy of Radiation (in million electronvolts, mev)
1.	H^3	12.5 years	β	0.018
2.	C^{14}	5760 years	β	0.155
3.	P^{32}	14.3 days	β	1.712
4.	S^{35}	87.1 days	β	0.167
5.	Cl^{36}	3.1×10^5 years	β	0.714
6.	K^{42}	12.5 hours	β	3.550
7.	Ca^{45}	152 days	β	0.255
8.	Fe^{55}	2.94 years	x-rays	–
9.	I^{125}	60 days	γ	0.035
10.	I^{131}	8.1 days	β	0.610
			γ	0.280

* **Half life** is the required for the loss of 50% of radioactivity. In other words, the time taken for half the atoms is a quantity of a radioactive substance to disintegrate is known as the half life.

Radioactive Isotopes. The radioactive isotopes are usually more useful as tracers than the stable isotopes since the analytical methods for their measurement are extremely sensitive. The biochemically-important radioactive isotopes are H^3 , C^{14} , P^{32} , S^{35} and Ca^{45} . All these emit β -rays and

1038 FUNDAMENTALS OF BIOCHEMISTRY

their nuclei, upon disintegration, produce electrons. The β -rays interact with the molecules through which they traverse causing ionization of the molecules. It is this ionization property which is used to measure quantitatively the amount of radioactive isotope present. Table 34-3 lists some properties of useful radioactive isotopes.

The most widely-used apparatus for the determination of radioactive isotopes is **Geiger-Müller counter or G-M tube** (Fig. 35-8). The functioning of this apparatus is based on the ability of the emitted radiation to ionize atoms. It consists of a large, round tube forming cathode with a fine wire stretched in the centre as anode. The fine wire is maintained at a high potential (1,000–2,500 volts) with respect of the outer cathode. The tube is filled with an easily ionized gas such as helium or argon and an organic quenching substance such as ethanol. The voltage as well as the gas filling is so adjusted that normally no current flows. The open end of the tube is covered with an extremely thin

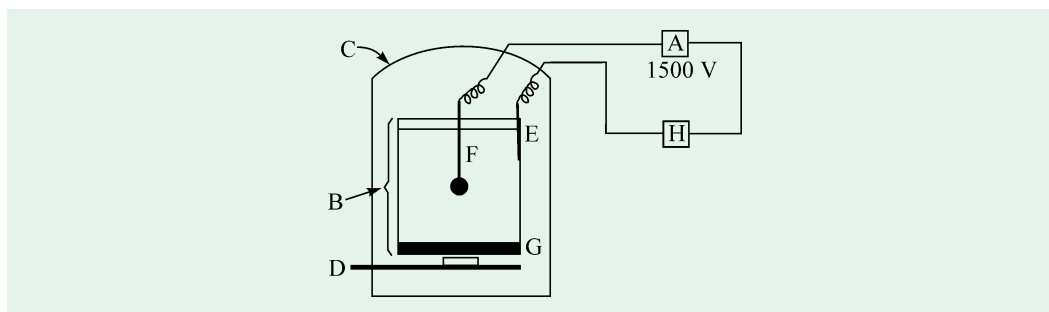

Fig. 35-8. Geiger-Müller tube and a scaler

[A = source of potential, B = Geiger-Müller tube, C = leadshield, D = sample pan holder, E = cathode shield, F = anode wire, G = mica window, H = scaler]

(After Cowgill and Pardee, 1957)

window of mica (1.5 to 2.0 mg/cm^2) or synthetic plastic. The radioactive material which is usually a solid is placed beneath this window. The radioactive particle enters the tube and ionizes the gas molecules with a subsequent release of a shower of electrons. These free electrons are then accelerated to the positive wire. As they progress through the gas, additional molecules are ionized. Thus, the tube becomes momentarily conductive. The resultant electrical pulse is collected in an electronic computing machine (called scaler) which records the number of such pulses in a predetermined time.

The **radioactive sample** to be counted is, however, in some instances a gas and is actually included in the filling of the counter tube.

The radioactivity of a sample is given in terms of its *specific radioactivity*, i.e., the number of counts per minute (*cpm*) per unit weight (milligram or micromole etc). The relationship of this quantity to the number of disintegrations per unit time depends on the counting efficiency of the system. The absolute unit of disintegration rate is the *curie*. A curie is defined as the amount of emitter which exhibits 3.7×10^{10} disintegrations per second (*dps*). More common units are a millicurie, mc (10^{-3} curie) and a microcurie, μc (10^{-6} curie).

The Geiger-Muller technique is being rapidly replaced nowadays by an alternative method called **scintillation counting**. It involves transformation of β or γ radiation into ultraviolet or visible light by the use of a *phosphor*. The phosphors are often highly aromatic substances such as *p*-terphenyl and have the property of emitting a light flash (or a scintillation) when they absorb radiation from a radioactive compound. The scintillations are detected by a sensitive photomultiplier and the resultant electrical pulses are collected in a scaler. *The scintillation technique has proved particularly useful for isotopes which emit low energy β particles such as H^3 , C^{14} etc.*

Although extremely sensitive, this method also suffers from certain *drawbacks*. They are :

(a) quenching of light flashes by coloured samples, and

(b) limited solubility of highly polar compounds in nonpolar solvents.

Therapeutic applications of radioactive emissions. Radioactive emissions, particularly of γ -rays, are frequently used to kill unwanted tissues. Some common examples are the radioactive sterilization of surgical accessories, partial destruction of over-active thyroids by I^{131} and the irradiation of tumours by Co^{60} and by Au^{198} or Ra^{226} .

Neutron activation. The radioactive isotopes are made usually by bombarding a suitable target with neutrons in an atomic pile. But sometimes it becomes also possible to bombard a biological sample directly so that a little element is converted into a radioactive isotope. Thus, O^{18} has been converted into F^{18} by neutron activation. Of special interest was the dramatic example of bombardment of a single hair of the Emperor Napoleon Bonaparte. The hair was, in fact, taken at the end of his life and is preserved since then. The hair, after this treatment, was found to possess a radioactive isotope of arsenic which could only have come from arsenic already present in the hair. This finding was evidenced to the fact that Napoleon died of *arsenic poisoning*.

SPECTROPHOTOMETRY

Principle. When a beam of incident light of intensity, I_o passes through a solution (Fig. 35–9), a part of it is reflected (I_r), a part absorbed (I_a) and rest transmitted (I_t), i.e.,

$$I_o = I_r + I_a + I_t$$

In colorimetric methods, I_r is eliminated because the measurement of I_o and I_t will be sufficient to determine I_a . For this purpose, the amount of light reflected (or I_r) is kept constant by using cells that have identical properties. I_o and I_t are then measured.

The mathematical relationship between the amount of light absorbed and the concentration of a substance can be shown by the following two fundamental laws, on which the spectrophotometry is based.

A. Lambert's law (= Bouguer's law). This law states that the amount of light absorbed is directly proportional to the length or *thickness* of the solution under analysis. Thus,

$$A = \log_{10} \frac{I_o}{I_t} = a_s b$$

[where A = absorbancy

a_s = absorbancy index characteristic for the solution

b = length or thickness of the medium.]

B. Beer's law. This law states that the amount of light absorbed is directly proportional to the *concentration* of the solute in solution. Thus,

$$\log_{10} \frac{I_o}{I_t} = a_s c$$

[where c = concentration of solute in solution.]

The combined **Beer-Lambert Law** then becomes :

$$\log_{10} \frac{I_o}{I_t} = a_s b c$$

If b is kept constant by employing a standard cell or cuvette, the above formula reduces to:

$$A = \log_{10} \frac{I_o}{I_t} = a_s c$$

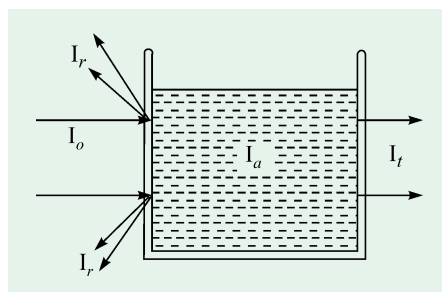

Fig. 35–9. Distribution of incident light passing through a solution contained in a cell

1040 FUNDAMENTALS OF BIOCHEMISTRY

The absorbancy index, a_s is defined as :

$$a_s = \frac{A}{CL}$$

[where C = concentration of absorbing material in gms/litre

L = distance in cms travelled by the light in solution.]

If one wishes to express the light absorption in terms of the molar concentration of the absorbing material, the molar absorbancy index, a_m will be equal to :

$$a_m = a_s M$$

[where M = molecular weight of the absorbing material.]

Spectrophotometer. A spectrophotometer has two fundamental parts : a source of radiant light and a monochromator. Fig. 35-10 outlines Beckman spectrophotometer. It consists of a prism. This disperses the radiant energy into a spectrum. A slit is also fixed which selects a narrow portion of the spectrum. The standard cell or cuvette is placed in a light-tight-unit. The incident light strikes the standard cell and emergent light passes into a photocell. The photocell changes the emerging light energy into measurable electrical energy.

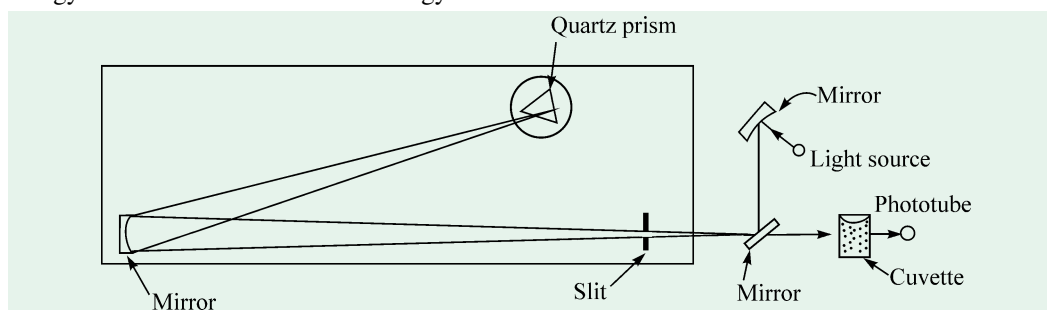

Fig. 35-10. Beckman spectrophotometer

(Adapted from Conn EE and Stumpf PK, 1966)

Applications. The technique finds many applications :

- It can be used in determining the concentration of a compound by measuring the optical density, provided the absorbancy index, a_s is known.
- The course of a reaction can be determined by measuring the rate of formation or disappearance of a light-absorbing compound.
- A compound can be identified by determining its absorption spectrum in the visible and ultraviolet region of the spectrum.

ELECTROPHORESIS

Principle. Migration of ions in an electric field at a definite pH is called **electrophoresis**. This method was developed by Arne W.K. Tiselius in 1937 and is based on the principle that the proteins migrate in an electric field except at the pH of their isoelectric point (refer page 218). And in a mixture of proteins, each protein with its characteristic electrical charge will respond differently to an applied electric potential. The rate of this electrophoretic migration (or 'mobility') depends on the pH of the medium, strength of the electric field, magnitude of the net charge on the molecule and the size of the molecule. A generalized diagram explaining the principle of gel electrophoresis for analyzing and sizing proteins is presented in Fig. 35-11.

ARNE W.K. TISELIUS

(LT, 1902-1971)

Tiselius, a Swedish physical biochemist, won the **1948 Nobel Prize in Chemistry** for the discovery of proteins in blood serum and for the development of electrophoresis as a technique for studying proteins.



Electrophoresis apparatus. Tiselius electrophoresis apparatus consists of compartmented cells forming a U tube, connected to an anode and a cathode compartment. The protein solution is placed at the bottom of the U tube. The U tube is kept immersed in a water bath at 4°C to minimize convection currents and the movement of the proteins is visualized by a Schlieren optical system.

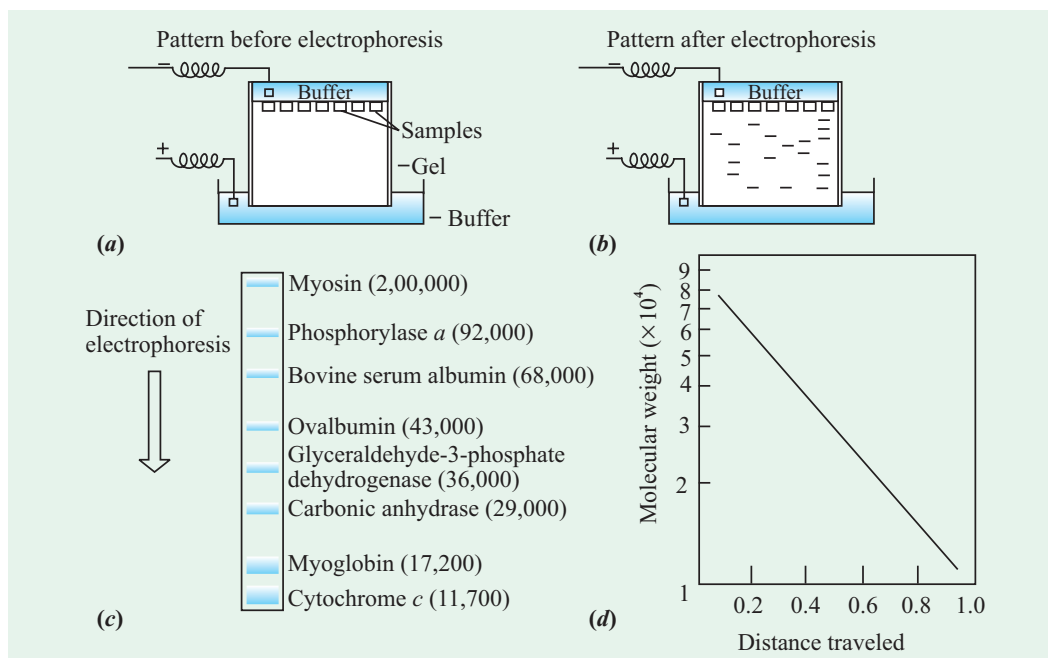

Fig. 35-11. Gel electrophoresis for analyzing and sizing proteins

- (a) Apparatus for slab-gel electrophoresis. Samples are layered in the little slots cut in the top of the gel slab. Buffer is carefully layered over the samples, and a voltage is applied to the gel for a period of usually 1-4 h.
- (b) After this time, the proteins have moved into the gel at a distance proportional to their electrophoretic mobility. The pattern shown indicates that different samples were layered in each slot.
- (c) Results obtained when a mixture of proteins was layered at the top of the gel in phosphate buffer, pH 7.2, containing 0.2% SDS. After electrophoresis, the gel was removed from the apparatus and stained with Coomassie Blue. The protein and its molecular weight are indicated next to each of the stained bands.
- (d) The logarithm of the molecular weight against the mobility (distance traveled) shows an approximately linear relationship.

(Source: Data of K Weber and M Osborn)

Consider that the protein solution is composed of 3 components, A, B and C and that these components carry charges of the same sign (either + or -) but of different magnitude. Before the electric field is applied, the solution will be homogeneous from ascending boundary to descending boundary. On the flow of current, the 3 components will separate. If the magnitude of the electric charge is in the order $A > B > C$, the components will separate as shown in Fig. 35-12. The faster moving component A will be present in pure form in the ascending boundary, as will C in the descending boundary. The component B will, however, always be mixed with A or with C. The rate of migration of the protein is measured by observing the movement of the boundary as a function of time. During electrophoretic migration, the concentration gradients will be set up at the boundaries. These gradients can be measured by optical systems since most of the proteins are colourless. Migration of coloured proteins like hemoglobin is, however, readily observed. The method described above is usually referred to as **free boundary electrophoresis** or simply **free electrophoresis** (*i.e.*, in free solution).

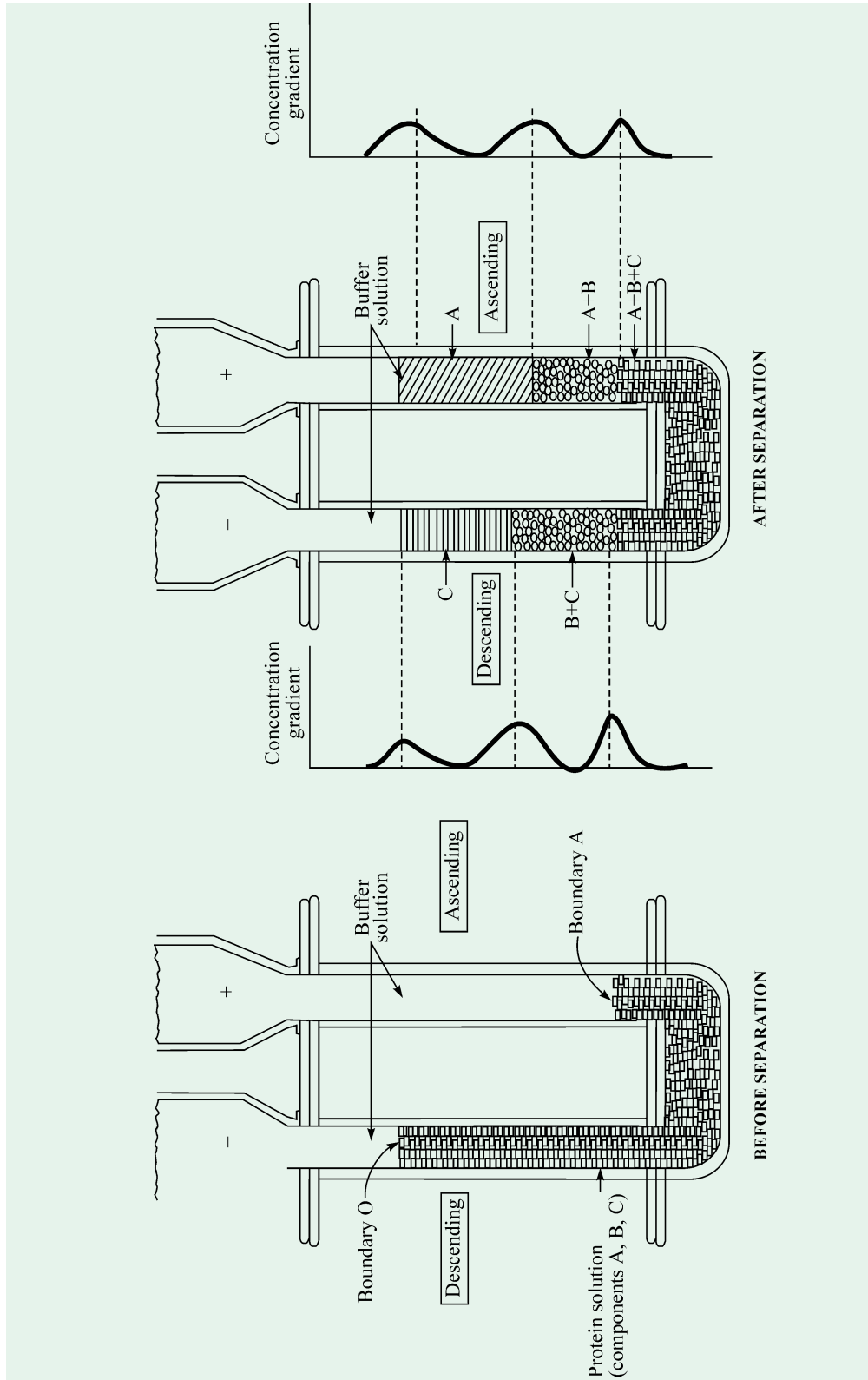

Fig. 35-12. U tube of an electrophoresis cell before and after electrophoretic separation

Modification. An important modification of the electrophoretic technique described above is the migration of proteins (and of other charged molecules) in an electric field passing through a solution supported by inert materials such as moistened filter paper, starch gel, silica gel, cellulose sponges or glass powder. This method, termed as **zone electrophoresis** or **ionophoresis**, allows ready separation of components of different mobility into zones. After separation, the different zones may be located by staining with dyes. The individual components can also be extracted from these zones. *Ionophoresis technique is, thus, a combination of electrophoresis and chromatography.* A schematic diagram of the zone electrophoresis apparatus using gel appears in Fig. 35–13.

Zone electrophoresis has proved much useful for the study of serum proteins and the cleavage products of proteins and of nucleic acids.

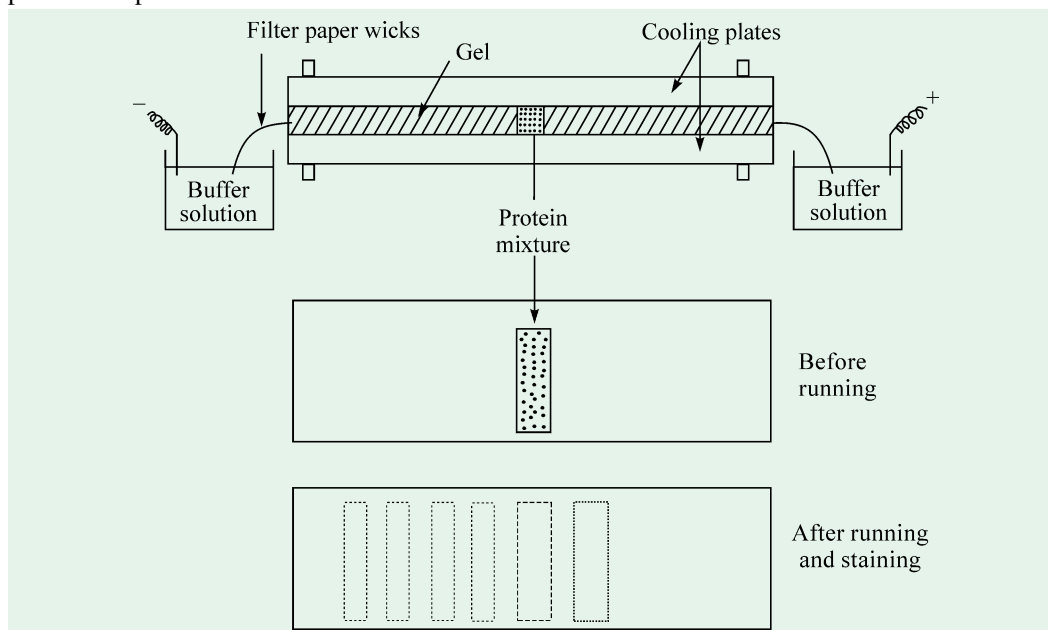

Fig. 35–13. Schematic representation of gel electrophoresis apparatus

[The two lower figures represent separation of protein mixtures.]

(Redrawn from Fairley JL and Kilgour GL, 1966)

ULTRACENTRIFUGATION

Principle. The ultracentrifuge method for determining the molecular weights of proteins was developed by Svedberg. In this method, the protein molecules are subjected to gravitational (centrifugal) forces greater in magnitude than the thermal forces whereby causing them to diffuse. Protein molecules are large-sized and hence described as macromolecules. Under high centrifugal forces, these molecules can be made to sediment toward one end of a centrifuge tube. By means of photographic and optical systems similar to those used in electrophoresis, it is possible to follow the rate of sedimentation. The rate of sedimentation for a protein under a certain centrifugal force depends on the density, shape and size of the molecule.

THEODORE SVEDBERG

(LT, 1884–1971)

Svedberg, a pioneer Swedish physical chemist, was responsible for much of the theoretical and practical development of centrifugation as a tool for studying large molecules. He was awarded the coveted **1926 Nobel Prize in Chemistry** for his work on colloids and macromolecular compounds. He also worked on nuclear chemistry, radiation biology, photographic processing and also worked out a method of making synthetic rubber during World War II.



1044 FUNDAMENTALS OF BIOCHEMISTRY

The fundamental equation, devised by Svedberg, for the molecular weight (M) of a protein is :

$$M = \frac{RTs}{D(1 - Vp)}$$

where,

- R = gas constant
 T = absolute temperature
 s = sedimentation constant
 D = diffusion constant in cm^2/sec
 V = partial specific volume of the protein
 p = density of the solvent.

The rate of sedimentation is usually expressed in terms of sedimentation constant, s which has the dimensions of time per unit of gravitational field and which usually lies between 1×10^{-13} and 200×10^{-13} sec. For convenience, the sedimentation constant of 1×10^{-13} is referred to as 1 Svedberg unit (S) and all sedimentation constants are then expressed in Svedberg units. A *Svedberg unit* is, thus, defined as the velocity of sedimenting molecule per unit of gravitational field or 1×10^{-13} cm/sec/dyne/g. The S value of an organelle or macromolecule is related to its molecular weight and shape. Typical S values are 1.83 for cytochrome c, 4.4 for bovine serum albumin and 185 for TMV. For the sake of uniformity, the sedimentation coefficient is customarily corrected to the value that would be obtained at 20 °C in a solvent with the density and viscosity of pure water. This is symbolized $S_{20, W}$. Table 35-4 and Fig. 35-14 indicate the values of $S_{20, W}$ Svedbergs for a variety of biological materials.

Table 35-4. Physical constants of some proteins

Protein	Molecular mass (kD)	Partial specific volume, $V_{20, W}$ ($\text{cm}^3 \cdot \text{g}^{-1}$)	Sedimentation coefficient, $S_{20, W}$ (S)
Lipase (milk)	6.7	0.714	1.14
Ribonuclease A (bovine pancreas)	12.6	0.707	2.00
Cytochrome c (bovine heart)	13.4	0.728	1.71
Myoglobin (horse heart)	16.9	0.741	2.04
α -chymotrypsin (bovine pancreas)	21.6	0.736	2.40
<i>Diphtheria</i> toxin	70.4	0.736	4.60
Cytochrome oxidase (<i>P. aeruginosa</i>)	89.8	0.730	5.80
Lactate dehydrogenase H (chicken)	150	0.740	7.31
Catalase (horse liver)	222	0.715	11.20
Fibrinogen (human)	340	0.725	7.63
Glutamate dehydrogenase (bovine liver)	1015	0.750	26.60
Turnip yellow mosaic virus protein	3013	0.740	48.80

(Adapted from Smith MH, 1970)

The diffusion coefficient or constant D may be defined as the quantity of material that diffuses per second across a surface 1 cm^2 in area. The partial specific volume V is equal to the reciprocal of the density of the molecule. *For most proteins, however, the value of V is in the range of 0.70 to 0.75.*

Ultracentrifuge. Using the above principle, Svedberg in 1925 devised an instrument called ultracentrifuge (Figs. 35-15 and 35-16). By this instrument, it is possible to get information on the purity of a protein, its, molecular weight and approximate dimensions. Two types of ultracentrifuges are now known :

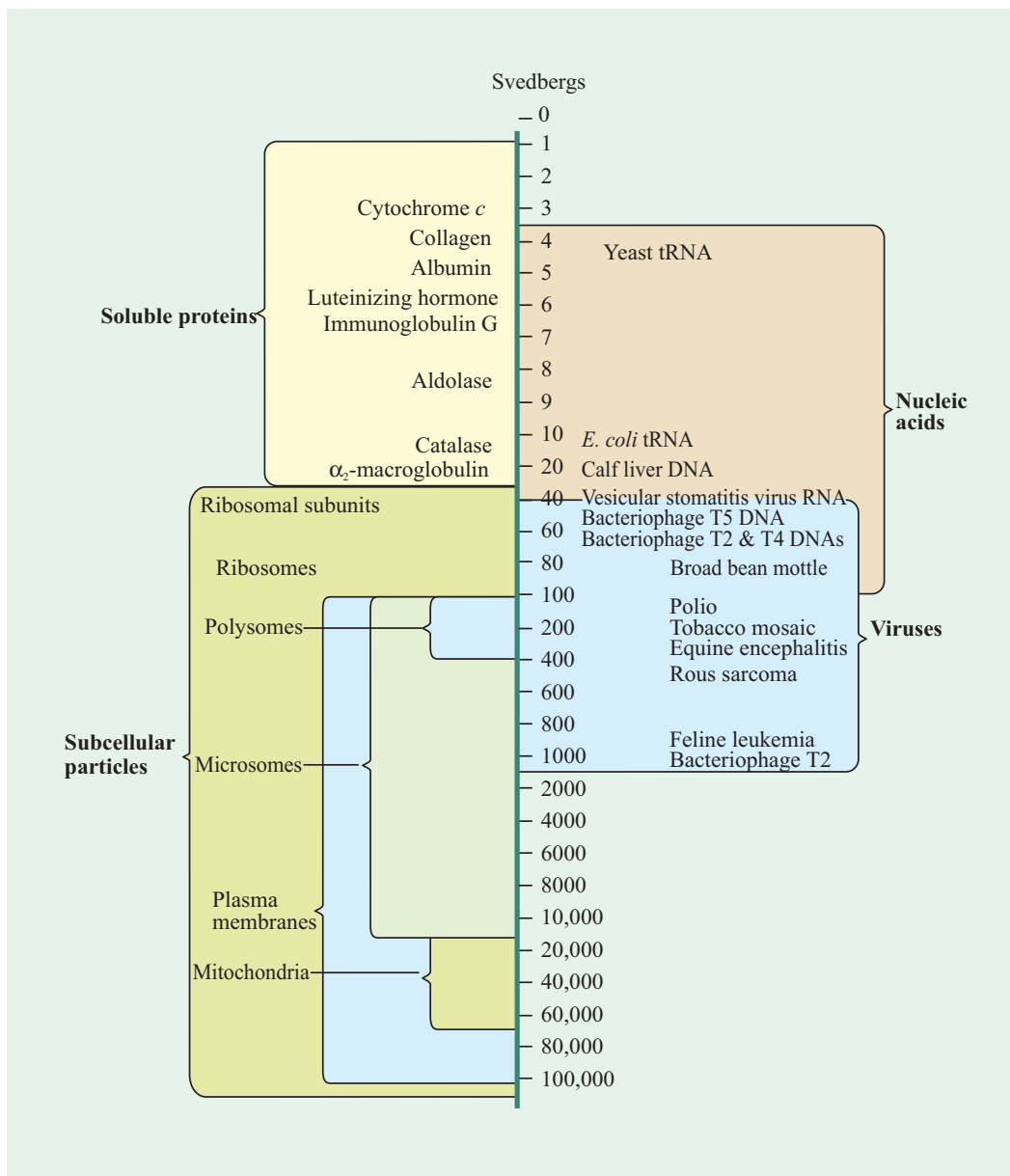

Fig. 35-14. The sedimentation coefficients in Svedbergs for some biological materials

(Courtesy : Beckman Instruments, Inc.)

- (a) *Low speed type*, with centrifugal forces of the order of 100 to 8,000 times gravity and having the maximum speed of about 40,000 rpm.
- (b) *Oil-turbine type*, with centrifugal forces of the order of 8,000 to 400,000 times gravity and having the maximum speed of about 80,000 rpm.

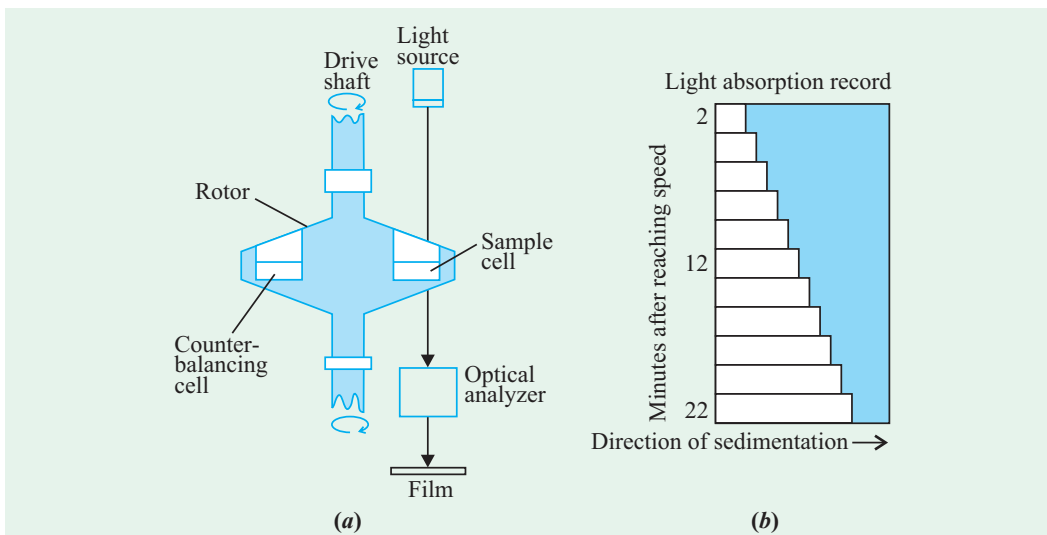

Fig. 35-15. Apparatus for analytical ultracentrifugation

- (a) The centrifuge rotor and method of making optical measurements.
- (b) The optical recordings as a function of centrifugation time. As the light-absorbing molecule sediments, the solution becomes transparent.

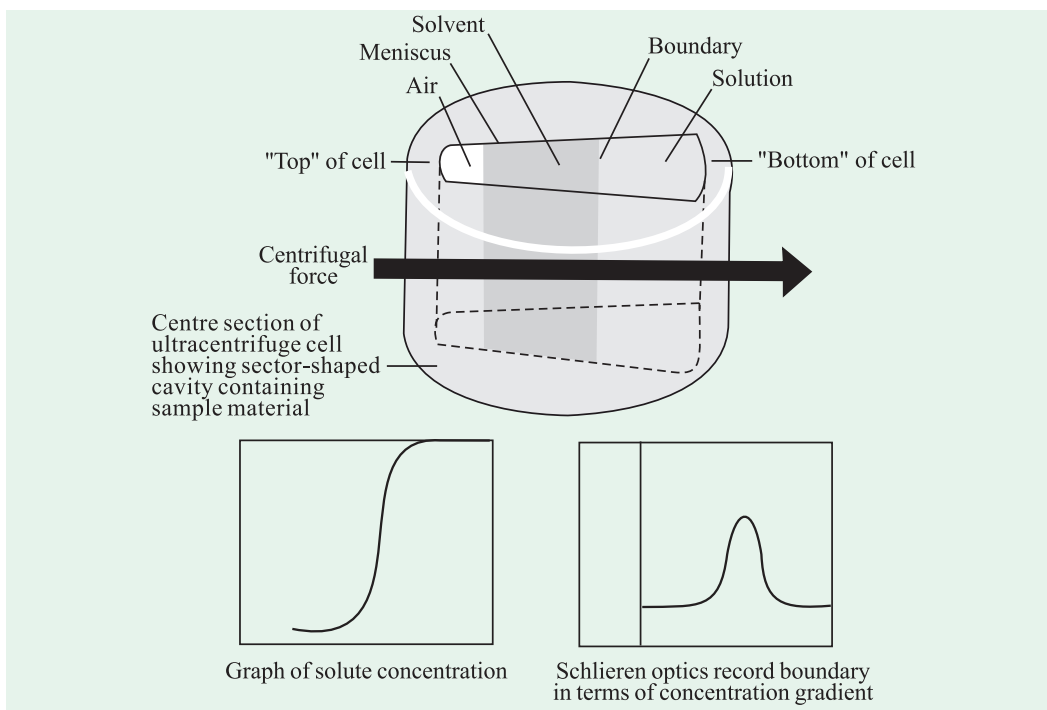

Fig. 35-16. Centre section of ultracentrifuge cell

[The solute molecules which are initially evenly distributed are forced towards the bottom of the cell by the centrifugal force. This migration creates at the top of the cell a region that is without solute molecules and contains only solvent molecules. A boundary is set up in the cell between solvent and solution in which concentration varies with the distance from the axis of rotation. The measurement of boundary movement which represents its movement of protein molecules, is the basis of analytical ultracentrifugation.]

(Courtesy : Beckman Instruments, Inc.)

REFERENCES

1. **Alexander P, Lundgren HP** : A Laboratory Manual of Analytical Methods of Protein Chemistry. Vols. 1–5, Pergamon Press, Oxford. 1966–69.
2. **Andrews AT : Electrophoresis** : Theory, Techniques and Biochemical and Clinical Applications. 2nd ed. Clarendon Press, Oxford (U.K.). 1986.
3. **Bailey JL** : Techniques in Protein Chemistry. 2nd ed. Elsevier, Amsterdam. 1967.
4. **Bergmeyer HU** : Principles of Enzymatic Analysis. Verlag Chemie. New York. 1978.
5. **Bier M (editor) : Electrophoresis** : Theory, Methods and Applications. Vols. I and II. Academic Press, Inc., New York. 1958, 1967.
6. **Bowen TJ** : An Introduction to ultracentrifugation. Wiley-Interscience. New York. 1970.
7. **Bragg L** : X-ray Crystallography. Sci. Amer., **219** : 58, 1968.
8. **Bruening G, Criddle R, Preiss J, Rudert F** : Biochemical Experiment. Wiley-Interscience, New York. 1970.
9. **Campbell ID, Dwek RA** : Biological Spectroscopy. Benjamin/cummings, Menlo Park. 1984.
10. **Chaykin S** : Biochemistry Laboratory Techniques. Wiley Eastern Private Ltd., New Delhi. 1970.
11. **Cooper TG** : The Tools of Biochemistry. Wiley, New York. 1977.
12. **Determan H** : Gel Chromatography. Springer-Verlag, Berlin. 1969.
13. **Dayl Z** : Separation Methods. Elsevier, Amsterdam. 1984.
14. **Frais F** : Practical Biochemistry. Butter Worths, London. 1972.
15. **Francis GE, Mulligan W, Wormall A** : Isotopic Tracers. The Athlone Press, London. 1954.
16. **Giddings JC, Keller RA (editors)** : Advances in Chromatography. 8 vols., Marcel Dekker, Inc., New York. 1966-1969.
17. **Grossman L, Moldave K** : Methods in Enzymology. Vol. 12–Nucleic Acids. Academic Press, Inc., New York. 1968.
18. **Harborne JB** : Phytochemical Methods. 1st ed., Chapman and Hall, London. 1973.
19. **Heftmann E (editor)** : Chromatography. 2nd ed., Reinhold Publishing Corp., New York. 1967.
20. **Hudson L, Hay PC** : Practical Immunology. Blackwell Scientific Publications, Oxford. 1980.
21. **James A, Prichard M** : Practical Physical Chemistry. 3rd ed., Longmans, London. 1975.
22. **Kates M** : Techniques in Lipidology. North Holland, Amsterdam. 1972.
23. **Morris C, Morris P** : Separation Methods in Biochemistry, Pitman, London. 1963.
24. **Parish JH** : Principles and Practice of Experiments with Nucleic Acids. Longmans, London. 1972.
25. **Plummer DT** : An Introduction to Practical Biochemistry. 3rd ed., McGraw-Hill, London. 1987.
26. **Schachman HK** : Ultracentrifugation in Biochemistry. Academic Press, Inc., New York. 1959.
27. **Segel IH** : Biochemical Calculations. John Wiley and Sons, Inc., New York. 1968.
28. **Shaw DJ** : Electrophoresis Academic Press, Inc., New York. 1969.
29. **Smith I** : Chromatographic and Electrophoretic Techniques. 4th ed., Vol. I–Chromatography. Vol II– Electrophoresis. William Heinemann Ltd., London. 1976.
30. **Stahl E** : Thin-layer Chromatography. A Laboratory Handbook. 2nd ed., Springer-Verlag, Berlin. 1969.
31. **Stein WH, Moore S** : Chromatography. Sci. Amer. **184 (3)** : 35, 1951.
32. **Svedberg T, Pedersen KO** : The Ultracentrifuge. Oxford Univ. Press., New York. 1940.
33. **Touchstone JC** : Practice of Thin Layer Chromatography. Wiley-Interscience. 1978.

1048 FUNDAMENTALS OF BIOCHEMISTRY

- 34. Umbreit WW, Burris RH, Stauffer JF :** Manometric Techniques and Related Methods for the Study of Tissue Metabolism. *4th ed., Burgess Publishing Co., Minneapolis. 1964.*
- 35. Van Holde, KE :** Physical Biochemistry. *2nd ed., Englewood Cliffs, N. J., 1971.*
- 36. Wang CH, Wills DL :** Radiotracer Methodology in Biological Science. *Prentice-Hall, New Jersey. 1965.*
- 37. Wilson K, Goulding KH (editors) :** A Biologist's Guide to Principles and Techniques of Practical Biochemistry. *3rd ed., Edward Arnold (Publisher's) Ltd., London. 1986.*
- 38. Williams VR, Williams HB :** Basic Physical Chemistry for the Life Sciences. *W.H. Freeman and Co., San Francisco. 1967.*

PROBLEMS

- The absorbance A of a solution is defined as

$$A = \log_{10} (I_0/I)$$
 in which I_0 is the incident light intensity and I is the transmitted light intensity. The absorbance is related to the molar absorption coefficient (extinction coefficient) ϵ (in $\text{M}^{-1} \text{cm}^{-1}$), concentration c (in M), and path length l (in cm) by

$$A = \epsilon lc$$
 The absorption coefficient of myoglobin at 580 nm is $15,000 \text{ M}^{-1} \text{cm}^{-1}$. What is the absorbance of a 1 mg ml^{-1} solution across a 1-cm path? What percentage of the incident light is transmitted by this solution?
- Tropomyosin, a 93-kd muscle protein, sediments more slowly than does hemoglobin (65 kd). Their sedimentation coefficients are 2.6S and 4.31S, respectively. Which structural feature of tropomyosin accounts for its slow sedimentation?
- The relative electrophoretic mobilities of a 30-kd protein and a 92-kd protein used as standards on an SDS-polyacrylamide gel are 0.80 and 0.41, respectively. What is the apparent mass of a protein having a mobility of 0.62 on this gel?
- Suppose that an enzyme is dissociated into 4 identical subunits and that you want to test for the enzymatic activity of the individual subunits. However, you must be sure that there are no tetramers remaining in the sample.
 - What chromatographic procedure would you choose to free the monomers from the tetramers?
 - How would you know where the tetramer would be if it were present?
- The density of DNA in CsCl is approximately 1.7 g/cm^3 and that of most proteins is approximately 1.3 g/cm^3 . What would you expect to be the density of a typical bacteriophage which is 50% protein and 50% DNA?
- A solution of a substance at a concentration of $32 \text{ }\mu\text{g/ml}$, having a MW of 423, has an absorbance of 0.27 at 540 nm measured with a 1-cm light path. What is the molar extinction coefficient at 540 nm, assuming that Beer's law is obeyed at an absorbance of 0.27?
- Details of the citric acid cycle were worked out by the use of :
 - x-ray crystallography
 - radioactive carbon compounds
 - ultracentrifugation
 - electron microscopy
- In two-dimensional chromatography and electrophoresis, such as is employed in fingerprinting technique, does it matter which is done first? Explain.
- A mixture of proteins is subjected to electrophoresis in 3 polyacrylamide gels, each having a different pH value. In each gel five bands are seen.
 - Can one reasonably conclude that there are only 5 proteins in the mixture. Explain.
 - Would the conclusion be different if a mixture of DNA fragments was being studied?