

Mitchell P. Fink
Michelle Hayes
Neil Soni
Editors

Classic Papers in Critical Care

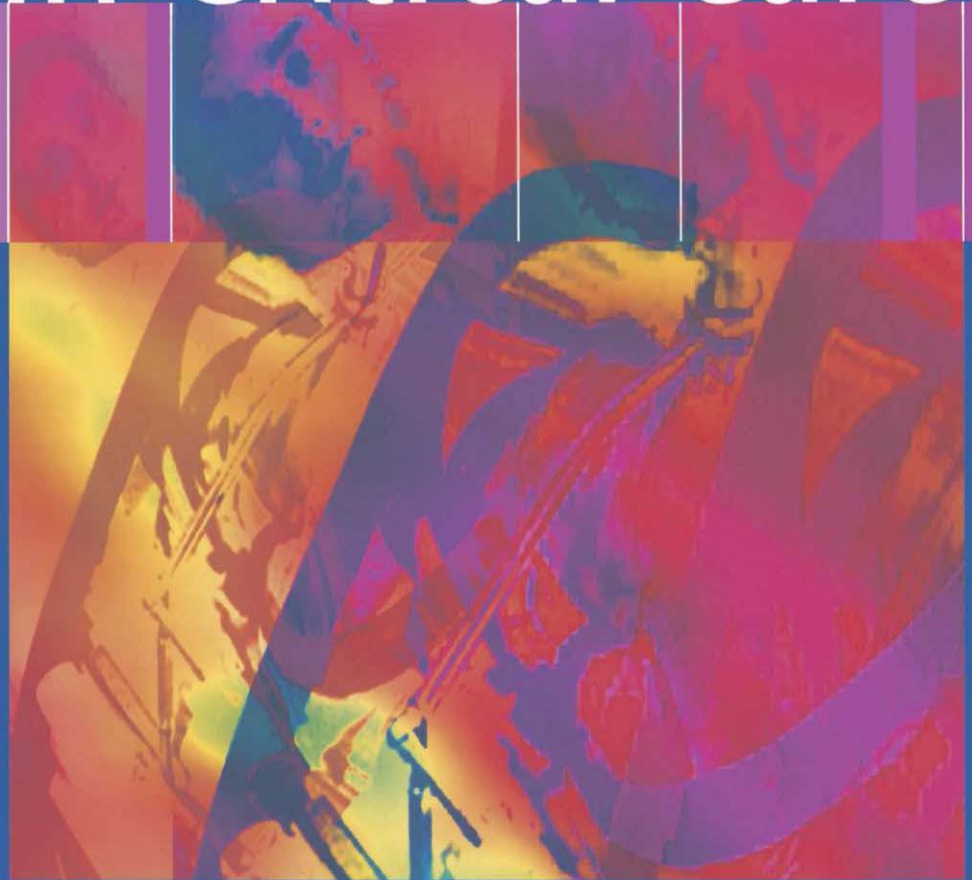

Second Edition

 Springer

Classic Papers in Critical Care

Second Edition

Mitchell Fink • Michelle Hayes • Neil Soni
Editors

Classic Papers in Critical Care

Second Edition

 Springer

Editors

Mitchell Fink, MD
Watson Professor of Surgery
Professor and Chairman Department
of Critical Care Medicine
University of Pittsburgh School of Medicine
Pittsburgh, PA, USA

Michelle Hayes, MD FRCA
Consultant in Intensive Care Medicine
Chelsea and Westminster Hospital
and
Honorary Senior Lecturer
Imperial College School of Medicine
London, UK

Neil Soni, MD FRCA FANZCA FJFICM
Consultant in Intensive Care Medicine
Chelsea and Westminster Hospital
and
Honorary Senior Lecturer
Imperial College School of Medicine
London, UK

British Library Cataloguing in Publication Data

Classic papers in critical care. - 2nd ed.

I. Critical care medicine

I. Fink, M. P. (Mitchell P.), 1948- II. Hayes, Michelle

III. Soni, Neil

616'.028

ISBN 978-1-84800-144-2 e-ISBN 978-1-84800-145-9

DOI 10.1007/978-1-84800-145-9

British Library Cataloguing in Publication Data

A catalogue record for this book is available from the British Library

Library of Congress Control Number: 2008926387

© Springer-Verlag London Limited 2008

1st edition published in 2003 by Bladon Medical Publishing, Oxfordshire, UK (ISBN 978-1-904218-21-0)

Apart from any fair dealing for the purposes of research or private study, or criticism or review, as permitted under the Copyright, Designs and Patents Act 1988, this publication may only be reproduced, stored or transmitted, in any form or by any means, with the prior permission in writing of the publishers, or in the case of reprographic reproduction in accordance with the terms of licences issued by the Copyright Licensing Agency. Enquiries concerning reproduction outside those terms should be sent to the publishers.

The use of registered names, trademarks, etc. in this publication does not imply, even in the absence of a specific statement, that such names are exempt from the relevant laws and regulations and therefore free for general use.

Product liability: The publisher can give no guarantee for information about drug dosage and application thereof contained in this book. In every individual case the respective user must check its accuracy by consulting other pharmaceutical literature.

Printed on acid-free paper

9 8 7 6 5 4 3 2 1

springer.com

Preface

Access to medical information has never been easier or quicker. Everything is at one's fingertips: Literally everything, and that can in itself be a problem. A search of any popular subject area will provide an almost limitless supply of information, and the difficulty is then sifting through that information to find what is needed. Add in a span of years when the information accrued, and the problem increases exponentially.

How often does one think "if only I had a list of the important papers that brought this topic to where we are today?" The intention of the editors of this book, *Classic Papers in Critical Care*, was to split the world of intensive care into a series of easily recognizable areas of interest, then to seek such individuals who might well have clear opinions on what was important and what was not, and to ask them to select and critique what they consider the classic papers in a specific field. To focus their minds, they were limited to ten papers. These are not necessarily the most quoted, the most influential, nor necessarily even the best papers, but those, which by virtue of content, thought process, or even just timing, are important to the individual choosing them.

They may be identical to your choices, or they may be markedly different and you may disagree with them entirely. Each contributor, has we hope, justified the reasons for their inclusion, and it is our hope that the reader will find it interesting. That it may assist the student, the examination candidate, those preparing talks, or those writing papers is also our hope and aspiration.

Preface to the Second Edition

This edition is a useful opportunity to update the previous edition. Only a few years have passed, and even in critical care there are not new classics for each section. Some potentially important papers have appeared, although it is probably too early to state whether they will stand the test of time, but they certainly look promising. Some older papers which were not considered classics previously have grown in stature since last assessed, and are also included. The new section could be described as the 'editors cut' and consists of new papers that in the editors view might become classics. These are papers that are influencing both thought and practice. The change in thought can accommodate new evidence, and so will persist, but only time will tell if the change in practice is sustained. We hope you find our selection of interest.

Acknowledgments

The editors wish to acknowledge the assistance of Reinhard Wenz in collating and checking the citation scores and the list of the top 500 papers.

Contents

Preface to the Second Edition	v
Contributors	xi
1 Ventilation	1
<i>Tom Whitehead and Arthur S. Slutsky</i>	
2 Lung Injury.....	31
<i>Timothy Evans and Julius Cranshaw</i>	
3 The Heart.....	59
<i>David Treacher</i>	
4 Severe Traumatic Brain Injury	87
<i>Hülya Bayir, Kimberly D. Statler, Margaret A. Satchell, Randall A. Ruppel, Robert S.B. Clark and Patrick M. Kochanek</i>	
5 The Gut and Its Role in Circulatory Shock	119
<i>Ulf H. Haglund</i>	
6 Renal Support.....	141
<i>Mark G.A. Palazzo</i>	
7 The Liver in Critical Illness.....	169
<i>Felicity Hawker</i>	
8 Burns	193
<i>David N. Herndon, Robert E. Barrow, Somes C. Guha and Jay K. Bhama</i>	
9 Trauma.....	215
<i>Frederick A. Moore</i>	
10 Clinical Sepsis	237
<i>David Bihari</i>	
11 Nutrition and Metabolism	281
<i>Jan Wernerman</i>	
12 Fluids.....	303
<i>Malcolm Fisher</i>	

13	Infection in the Intensive Care Unit	327
	<i>Dennis G. Maki</i>	
14	Infectious Diseases: An Intensive Care Clinician's Perspective	357
	<i>Neil Soni</i>	
15	Vasoactive and Cardiotonic Drugs	383
	<i>Jean-Louis Vincent</i>	
16	Pain Relief and Sedation in Intensive Care	407
	<i>Bernadette Currer and Maire Shelly</i>	
17	Monitoring.....	427
	<i>E. Makings and C.J. Hinds</i>	
18	Scoring Systems	449
	<i>Derek C. Angus</i>	
19	Ethics.....	473
	<i>Charles L. Sprung</i>	
20	Cytokines.....	495
	<i>Helen F. Galley and Nigel R. Webster</i>	
21	Pediatric Critical Care	517
	<i>Bradley P. Fuhrman</i>	
22	Recent Papers	539
	<i>Michelle Hayes and Neil Soni</i>	
	Frequently Cited Papers in Critical Care	561
	The 25 most frequently mentioned authors in articles on Critical Care and related subjects. The time periods 1970–2008 as total, 2002–2008 and 1998–2002 have been shown.....	589
	Index	593

Contributors

Derek C. Angus, MB, ChB, MPH, MRCP(UK), FCCM
Associate Professor of Critical Care Medicine, Medicine and Health Services Administration,
Department of Critical Care Medicine, University of Pittsburgh, Pittsburgh, PA, USA

Robert E. Barrow, PhD
Fellow in Burn Surgery UTMB, Department of Surgery, Shriners's Burns Hospital, Galveston, TX, USA

Hülya Bayir, MD
Fellow in Critical Care Medicine, Children's Hospital of Pittsburgh, Pittsburgh, PA, USA

Jay K. Bhamra, MD
Surgical Resident, Division of General Surgery, Michael E. DeBakey Department of Surgery, Baylor
College of Medicine, Houston, TX, USA

David Bihari, MA(Cantab), MBBS(Lond), FRCP(Long), FRACP, FJFICIM
Associate Professor (University of NSW), Senior Staff Specialist in Intensive Care, Intensive Care Unit,
Prince of Wales Hospital, Sydney, NSW, Australia

Robert S.B. Clark, MD
Associate Professor, Critical Care Medicine, Children's Hospital of Pittsburgh, Pittsburgh, PA, USA

Julius H. Cranshaw, MRCP, FRCA
Consultant in Anesthesia and Critical Care Medicine, The Royal Bournemouth Hospital,
Bournemouth, UK

Bernadette Curren, FRCA
Consultant Anesthetist, Stepping Hill Hospital, Stockport, UK

Timothy W. Evans, BSc MD PhD DSc FRCP FRCA EDICM FMedSci
Professor of Intensive Care Medicine, Royal Brompton Hospital, London, UK

Malcolm Fisher, MB, ChB, FJFICM, FRCA, FANZCA, MD
Clinical Professor, Intensive Therapy Unit, Royal North Shore Hospital, St Leonard's, NSW, Australia

Bradley P. Fuhrman, MD
Professor of Pediatrics and Anesthesiology, Children's Hospital of Buffalo, Buffalo, NY, USA

Helen F. Galley, PhD, FIMLS
Senior Lecturer in Anesthesia and Intensive Care, Institute of Medical Sciences, University of Aberdeen,
Aberdeen, UK

Somes C. Guha, MD
Department of Emergency Medicine, Parkersburg, WV, USA

Ulf Haglund, MD, PhD

Professor and Surgeon-in-Chief, Department of Surgery, University Hospital, Uppsala University, Uppsala, Sweden

Felicity H. Hawker, FJICM

Director, Intensive Care Unit, Cabrini Hospital, Melbourne, Australia

David N. Herndon, MD

Jesse Jones Distinguished Chair in Burn Surgery, Professor of Surgery, Department of Surgery, Shriners' Burns Hospital, Galveston, TX, USA

Charles J. Hinds, FRCA, FRCP

Consultant and Senior Lecturer in Anesthesia and Intensive Care, Intensive Care Unit, St Bartholomew's Hospital, London, UK

Patrick M. Kochanek, MD

Professor and Vice Chairman, Critical Care Medicine, Director, Safar Centre for Resuscitation Research, Pittsburgh, PA, USA

Dennis G. Maki, MD

Ovid O. Meyer Professor of Medicine, Head of Infectious Diseases, Center for Trauma and Life Support, University of Wisconsin Medical School, Madison, WI, USA

Ellen A. Makings, MB, BS, FRCA

Research Fellow in Intensive Care Medicine, St Bartholomew's Hospital, London, UK

Frederick A. Moore, MD

Professor of Surgery, Department of Surgery, University of Texas, Houston Medical School, Houston, TX, USA

Mark G.A. Palazzo, MB, ChB, FRCA, FRCP, MD

Chief of Critical Care Services (Hammersmith Hospitals NHS Trust), Director of Critical Care, Charing Cross Hospital, London, UK

Randall A. Ruppel, MD

Assistant Professor, Critical Care Medicine, Children's Hospital of Pittsburgh, Pittsburgh, PA, USA

Margaret A. Satchell, MD

Assistant Professor, Mount Sinai School of Medicine, New York, NY, USA

Maire P. Shelly, FRCA

Consultant in Anesthesia and Intensive Care, Acute Intensive Care Unit, Wythenshawe Hospital, Manchester, UK

Arthur S. Slutsky, MD

Professor of Medicine, Surgery, and Biomedical Engineering, Director, Interdepartmental Division of Critical Care, University of Toronto, Vice President (Research), St Michael's Hospital, Toronto, ON, Canada

Neil Soni

Consultant in Intensive Care Medicine, Chelsea and Westminster Hospital, Honorary Senior Lecturer, Imperial College School of Medicine, London, UK

Charles S. Sprung, MD

Department of Anesthesiology and Critical Care Medicine, Hadassah University Hospital, Ein-Karem, Jerusalem

Kimberly D. Statler, MD

Division of Critical Care, Department of Pediatrics, The University of Utah School of Medicine, Salt Lake City, UT, USA

David F. Treacher, MA, FRCP

Consultant in Intensive Care, Department of Intensive Care, Guy's and St Thomas' NHS Trust, London, UK

Jean-Louis Vincent, MD, PhD

Professor of Intensive Care, Erasme University Hospital, Brussels, Belgium

Nigel R. Webster, BSc, MB, ChB, PhD, FRCA, FRCP

Professor of Anesthesia and Intensive Care, Institute of Medical Sciences, University of Aberdeen, Aberdeen, UK

Reinhard Wentz, Dipl Bibl

Librarian, Chelsea & Westminster Campus, Imperial College Library and Information Service, London, UK

Jan Wernerman, MD, PhD

Professor in Anesthesia and Intensive Care, Karolinska Institute, Stockholm, Sweden

Tom Whitehead

Interdepartmental Division of Critical Care, St Michael's Hospital Toronto, Ontario, Canada

Ventilation

Tom Whitehead and Arthur S. Slutsky

Introduction

The concept of respiratory support was described by Vesalius in the sixteenth century, but its successful application to the critically ill is relatively modern. Negative pressure ventilators were occasionally used to treat patients with acute respiratory failure in the first half of the twentieth century, but they were expensive, fraught with technical problems, and did not protect the airway. During the polio epidemic of 1952 in Denmark, the large numbers of patients presenting with acute respiratory failure and bulbar problems motivated the highly successful use of positive pressure ventilation via tracheostomy, as described below in the paper by Lassen. This event may be considered as the birth of critical care medicine. Since then, numerous studies, accumulating clinical experience, and technological advances have greatly improved our ability to ventilate the critically ill.

It is an important principle that mechanical ventilation is not a treatment in itself, rather a supportive measure while the underlying disease process runs its course or is treated. Moreover, mechanical ventilation itself, and associated factors (e.g. endotracheal tubes), can be harmful, particularly when the lungs are abnormal. Much of the progress in this field during the past 30 years has been in demonstrating these harmful effects, and preventing or minimizing them.

In 1975, Webb and Tierney showed that ventilation of rats with high pressure and volume causes pulmonary edema. Subsequently, Dreyfuss and colleagues established that high distending volume, rather than pressure, is the harmful factor. The clinical importance of this was not immediately appreciated. Ventilated patients with non-compliant lungs, notably those with acute respiratory distress syndrome (ARDS), require high inflation pressures, but the tidal volumes do not approach those causing damage in animal studies. However, CT scanning and the work of Gattinoni and others have clearly shown that ARDS does not affect the lung uniformly. Areas of normal lung, with normal compliance, remain. These areas would be over-distended, and thus damaged, by high inflation pressures. This offers a likely explanation for the improvement in mortality of ARDS patients when ventilated with limited pressure or low tidal volume, as demonstrated in Hickling's series of 1990, and in the recent prospective study by the ARDSnet. The precise mechanism by which high tidal volume ventilation is harmful to ARDS patients is not known. However, the finding by Tremblay *et al.* that injurious ventilatory strategies can increase the production of cytokines within the lung has led to the theory that it is due to distal organ dysfunction caused by inflammatory factors released from the lungs. It is notable that most patients with ARDS do not die as a direct result of the respiratory failure.

The application of positive end-expiratory pressure (PEEP) has been shown to improve oxygenation and reduce lung injury, at least in animals. However, it may also diminish cardiac output and can potentially over-distend and damage the lung. These conflicting influences were well studied by Suter and colleagues in 1975, who provided a rationale for establishing the 'best PEEP' in individual patients, based on sound physiological principles. Another major advance in lessening the complications of mechanical ventilation was the realization that the lungs do not necessarily reach their passive FRC at end-expiration, especially in patients with severe airway obstruction. Minimization of this 'auto-PEEP' during ventilation has led to decreases in mortality in patients with status asthmaticus.

An integral part of conventional ventilation is the use of an endotracheal tube. There are a number of complications of endotracheal intubation, and Brochard and colleagues

have demonstrated that non-invasive ventilation can reduce mortality in selected patients with exacerbations of chronic obstructive pulmonary disease. Equally, in those who are intubated, it is desirable for weaning and extubation to occur as soon as it is safe to do so. The study by Yang and Tobin provided insight into how to predict which patients will be weaned successfully.

We are optimistic that current and future research will further advance the practice of mechanical ventilation in the critically ill. New ventilatory techniques, such as proportional assist and high frequency oscillation, are promising. Meanwhile, research at the cellular level may identify therapeutic targets to minimize ventilator-induced lung injury.

Title

A preliminary report on the 1952 poliomyelitis epidemic in Copenhagen with special reference to the treatment of acute respiratory insufficiency

Author

Lassen HCA

Reference

Lancet 1953; **1**: 37–41

Abstract

Not available

Summary

This paper describes the extraordinary events at Blegdan Hospital in Copenhagen during the poliomyelitis epidemic of 1952.

Between 24 July and 3 December 1952, 2722 patients were admitted to the institution with acute poliomyelitis. Of these, 866 had paralysis and 316 had some degree of respiratory insufficiency. In 4 months, the hospital faced three times as many patients with respiratory insufficiency as it had in the previous 10 years. At any one time, up to 70 patients required ventilatory support, and Dr Lassen candidly admits that the hospital was in 'a state of war'.

At the start of the battle, negative pressure devices were the standard tools for ventilatory support. However, the hospital possessed only one tank and six cuirass respirators. Furthermore, results using this equipment in the sporadic cases before the epidemic were poor (mortality > 80%), and had not been improved by the introduction of tracheostomy in 1948.

The equipment and techniques available for patients with respiratory failure at the outbreak of the epidemic were inadequate, and this was reflected in mortality of 87% during the first month. At this point, after consultation with anaesthetist Dr Bjorn Ibsen, treatment for these cases was changed to include:

1. Early tracheostomy just below the larynx in those unable to maintain an unobstructed airway.
2. Suctioning and bronchoscopy via the tracheostomy.
3. Postural drainage.
4. Positive pressure ventilation via a cuffed rubber tube inserted into the tracheostomy (see [Figure1-2](#)).

Two hundred patients required continuous or intermittent ventilation, some over 3 months. Insufflation was carried out manually, by medical students working in shifts.

The change in mortality for cases of respiratory insufficiency following the introduction of these techniques was striking, falling from 87% to 40%.

Citation count

192

Related references

1. Drinker P, Shaw LA. An apparatus for the prolonged administration of artificial respiration. A design for adults and children. *J Clin Invest* 1929; **7**: 229–247.
2. Lassen HCA (ed). *Management of Life-threatening Poliomyelitis*. Edinburgh: E & S Livingstone, 1956.



Fig. 1-1. Typical equipment available for respiratory failure in 1952: an iron lung (left) and a Kifa cuirass (right). (Image of child in iron lung reproduced courtesy of the WHO Global Polio Eradication Initiative. Image of adult reproduced from Lassen HCA (ed). *Management of Life-threatening Poliomyelitis*. Edinburgh: E & S Livingstone, 1956.)

Key message

Mortality from acute respiratory insufficiency (due to poliomyelitis) can be reduced by tracheostomy, suctioning, postural drainage, and positive pressure ventilation.

Why it's important

This experience heralded the widespread use of positive pressure ventilation for acute respiratory failure, and may be considered the beginning of the modern era of mechanical ventilation, and indeed the origin of the specialty of intensive care medicine.

Strengths

This paper is both a landmark in medical science and a fascinating historical document.

Relevance

From the experiences gained in positive pressure ventilation, Lassen highlighted a number of problems that would be investigated for decades. These included the deleterious effect of prolonged insufflation on cardiac output, problems with weaning, and the benefits of timing insufflation to coincide with spontaneous respiratory effort.

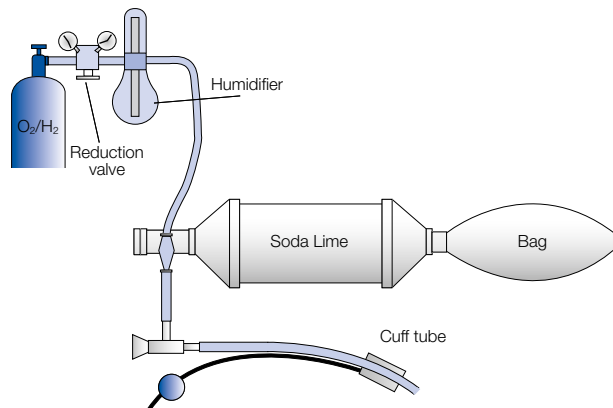

Fig. 1-2. A polio patient with respiratory insufficiency being ventilated manually via a tracheostomy (left). A schematic diagram of the ventilation circuit is shown. (Figures reproduced from Lassen HCA (ed). *Management of Life-threatening Poliomyelitis*. Edinburgh: E & S Livingstone, 1956.)

Title

Experimental pulmonary edema due to intermittent positive pressure ventilation with high inflation pressures: protection by positive end-expiratory pressure

Author

Webb HH, Tierney DF

Reference

Am Rev Respir Dis 1974; **110**: 556–565

Abstract

We used a small animal respirator to ventilate normal, anesthetized rats with room air at peak inspiratory pressures of 14, 30, or 45 cm H₂O and no added end-expiratory pressures (intermittent positive pressure breathing [IPPB] 14/0, high inspiratory positive pressure breathing [HIPPB] 30/0, HIPPB 45/0). Other rats were ventilated with the same high inspiratory pressures, but with an added end-expiratory pressure of 10 cm H₂O (positive end-expiratory pressure [PEEP] 30/10, PEEP 45/10). Control rats that were not ventilated and the IPPB 14/0 group showed no pathologic lung changes. The HIPPB 30/0 and the PEEP 30/10 groups had perivascular edema, but no alveolar edema. The HIPPB 45/0 animals had alveolar and perivascular edema, severe hypoxemia, and decreased dynamic compliance, and died within one hour. In contrast, the PEEP 45/10 animals had no alveolar edema and survived. We postulate that interstitial perivascular edema develops from ventilation with high inflating pressures by mechanisms of lung interdependence, which decrease the pressure in the perivascular tissues. Alveolar edema induced by HIPPB 45/0 may result from surfactant depletion because of large excursions of alveolar surface area, and a low surface tension at end-expiration.

Summary

This landmark study examined the effects of different inflation pressures and the presence or absence of PEEP on lung histology, lung compliance, and gas exchange using a rat model. The anesthetised animals were ventilated with room air via tracheostomy for 1 hour (or until death), with a peak airway pressure (PAP) of 14, 30, or 45 cmH₂O. A further control group received no ventilation. A PEEP of 10 cmH₂O was applied to half of the animals ventilated at PAPs of 30 and 45 cmH₂O. The tidal volumes were correspondingly higher in those animals ventilated at higher pressures for a given level of PEEP.

Unventilated lungs and those ventilated with a PAP of 14 cmH₂O showed no histological changes. There was mild perivascular edema in the rats ventilated at 30 cmH₂O, with or without PEEP, and in the rats ventilated at 45 cmH₂O with PEEP. In contrast to these mild derangements, all rats ventilated at 45 cmH₂O without PEEP had marked hypoxia and died before the end of the hour. The lungs from this group had reduced compliance and severe perivascular and alveolar edema.

Citation count

451

Key message

In an animal model, severe pulmonary edema and lung damage were observed following ventilation with high peak airway pressures corresponding to values used in clinical practice. The addition of 10 cmH₂O appeared to prevent this injury.

Why it's important

At the time of publication, the importance and even the existence of ventilator-induced lung injury, other than overt air leaks, was questioned. This study was the first to identify both major factors currently thought to play a role in ventilator-induced lung injury: over-distension, and ventilation at low lung volumes.

Strengths

1. Dramatic demonstration of the detrimental effects of mechanical ventilation in animals with normal lungs.
2. Use of airway pressures relevant to clinical practice.

Weaknesses

1. No attempt to control for the cardiovascular effects of the high pressure ventilatory strategy.
2. The changes observed were probably due to differences in the tidal volumes rather than pressure *per se*.
3. The results may not apply to humans; small animals are more susceptible to high ventilation pressures.

Relevance

This study provides the bedrock on which later studies on ventilator-induced lung injury were based.

Title***Optimum end-expiratory airway pressure in patients with acute pulmonary failure***

Author

Suter PM, Fairley B, Isenberg MD

Reference*N Engl J Med* 1975; **292**: 284–289

Abstract

To determine whether in the management of pulmonary failure, the maximum compliance produced by positive end-expiratory pressure coincides with optimum lung function, 15 normovolemic patients requiring mechanical ventilation for acute pulmonary failure were studied. The end-expiratory pressure resulting in maximum oxygen transport (cardiac output \times arterial oxygen content) and the lowest dead-space fraction both resulted in the greatest total static compliance. This end-expiratory pressure varied between 0 and 15 cm of water and correlated inversely with functional residual capacity at zero end-expiratory pressure ($r = -0.72$, $p \leq 0.005$). Mixed venous oxygen tension increased between zero end-expiratory pressure and the end-expiratory pressure resulting in maximum oxygen transport, but then decreased at higher end-expiratory pressures. When measurements of cardiac output or of true mixed venous blood are not available, compliance may be used to indicate the end-expiratory pressure likely to result in optimum cardiopulmonary function.

Summary

Suter and colleagues made a careful study of the cardiopulmonary physiology of 15 mechanically ventilated patients with acute respiratory failure secondary to major trauma, surgery, infection, or metabolic disturbance. All had a pulmonary artery catheter, enabling assessment of cardiac output and mixed venous oxygenation. With tidal volumes set between 13 and 15 ml/kg, positive end-expiratory pressure was increased from zero to a level which 'markedly decreased cardiac output'. Total lung and chest wall compliance and functional residual capacity were measured.

The arterial oxygen content increased and the intrapulmonary shunt decreased with increasing levels of PEEP. However, the cardiac output fell at higher levels of PEEP, tending to reduce oxygen transport. The term 'best PEEP' was coined to describe the value at which oxygen transport was maximal (Figure 1-3). This value was highly variable among patients, but there was a loose negative correlation between the initial FRC and the best PEEP, suggesting that its benefits are due to lung recruitment. Furthermore, the value of best PEEP corresponded to that which maximized the lung's compliance.

Citation count

702

Related references

1. Barach AL, Martin J, Eckman M. Positive pressure respiration and its application to the treatment of acute pulmonary edema. *Ann Intern Med* 1938; **12**: 754–795.
2. Falke KJ, Pontoppidan H, Kumar A, Leith DE, Geffin B, Laver MB. Ventilation with end-expiratory pressure in acute lung disease. *J Clin Invest* 1972; **51**: 2315–2323.

Key message

The value of PEEP at which cardiorespiratory function is optimized coincides with that producing maximum compliance in the lung, as might be predicted on theoretical grounds.

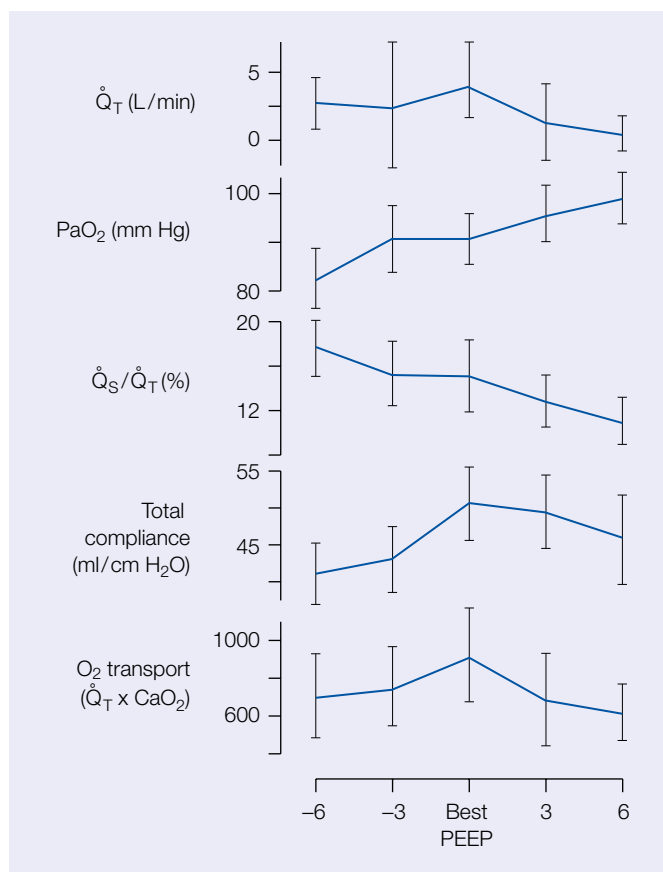

Fig. 1-3. Graphic representation of the influences of positive end-expiratory pressure (PEEP) on cardiorespiratory parameters. As PEEP increases, shunt fraction (Q_S/Q_T) decreases and arterial oxygen tension (PaO_2) increases. However, cardiac output (Q_T) falls, tending to reduce oxygen transport at high PEEP. 'Best' PEEP is the value allowing maximum O_2 transport, and corresponds to the PEEP at which lung compliance is greatest. (Adapted from Figures 3 and 4 of original article.)

Why it's important

The application of PEEP can have both beneficial and harmful effects. This paper carefully and clearly analyzes the physiological basis for 'best PEEP' and how to judge its value. It provides an integrated approach to assessment of ventilatory parameters, taking into account not just gas exchange, but the relationship between lung mechanics, hemodynamics, and oxygen transport. It has had a great impact on how PEEP has been applied in the intensive care setting.

Weaknesses

Only 15 patients with heterogeneous clinical conditions were studied, making the error margins wide.

Relevance

The judgement of 'best PEEP' and its theoretical basis remain controversial. This paper is still useful in understanding the inter-relationship between lung mechanics, hemodynamics, and oxygenation, and in determining how to set PEEP in individual patients.

Title***Occult positive end-expiratory pressure in mechanically ventilated patients with airflow obstruction: the auto-PEEP effect***

Author

Pepe PE, Marini JJ

Reference*Am Rev Respir Dis* 1982; **126**: 166–170

Abstract

Alveolar pressure can remain positive throughout the ventilatory cycle of mechanically-ventilated patients with airflow obstruction, even when positive end-expiratory pressure (PEEP) is not applied intentionally. The increase in intrathoracic pressure associated with this 'auto-PEEP' phenomenon can severely depress cardiac output, as well as elevate the end-expiratory pulmonary artery wedge pressure. Such effects may be exaggerated in patients with chronic obstructive pulmonary disease because abnormally compliant lungs transmit a high fraction of alveolar pressure to intrathoracic vessels. Failure to recognize the hemodynamic consequences of auto-PEEP may lead to inappropriate fluid restriction or unnecessary vasopressor therapy. Although not apparent during normal ventilator operation, the auto-PEEP effect can be detected and quantified by a simple bedside maneuver: expiratory port occlusion at the end of the set exhalation period.

Summary

This commentary describes the phenomenon of occult positive end-expiratory pressure (PEEP) or auto-PEEP that occurs in ventilated patients with chronic obstructive pulmonary disease (COPD). Incomplete lung emptying between mechanical breaths may be appreciated by observing persistent expiratory flow up to the moment of the next ventilator-induced inspiration, or – as the authors advocate – by direct measurement of the end-expiratory pressure after occluding the expiratory port, allowing pressure within the airways to equalize.

The three case histories given illustrate the serious cardiovascular consequences of auto-PEEP. The raised intrathoracic pressure diminishes venous return and cardiac output. This may manifest as oliguria or frank hypotension. Pulmonary artery catheters give misleading results in these circumstances, as they indicate luminal pressures relative to atmosphere, rather than transmural pressures that determine cardiac function. Thus, PA catheters overestimate filling pressures, leading to inappropriate fluid restriction or use of inotropes (Figure 1-4).

The critical issue is that the gas trapping that occurs is 'occult' in the sense that it cannot be measured at the airway opening without special maneuvers, and it is incumbent on the clinician to think about this phenomenon in the appropriate clinical setting. Once detected, measures to limit auto-PEEP include treatment of airway obstruction, maximizing expiratory flow time, use of intermittent mandatory ventilation, reducing the ventilatory demand (such as by treating fever and metabolic acidosis), and minimizing minute ventilation, which may lead to hypercapnia.

Citation count

443

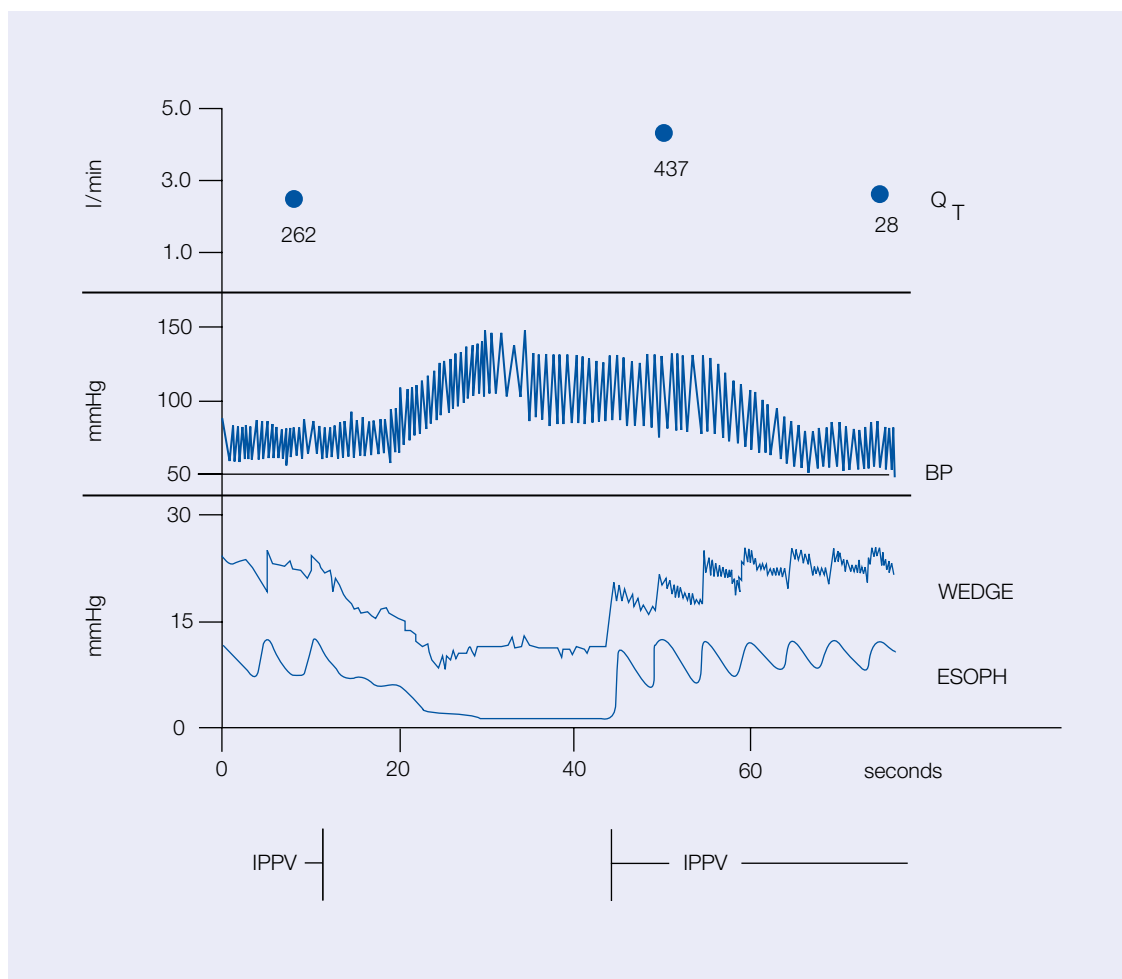

Fig. 1-4. The effect of auto-PEEP in a patient with severe airflow obstruction. As intermittent positive pressure ventilation (IPPV) is discontinued, intrathoracic pressure falls (indicated by the esophageal pressure – ESOPH), allowing cardiac filling to increase, with a concomitant rise in the cardiac output (QT) and blood pressure (BP). (Adapted from the original article.)

Related references

1. Darioli R, Perret C. Mechanical controlled hypoventilation in status asthmaticus. *Am Rev Respir Dis* 1984; **129**: 385–387.
2. Tuxen DV, Williams TJ, Scheinkestel CD, Czarny D, Bowes G. Use of a measurement of pulmonary hyperinflation to control the level of mechanical ventilation in patients with acute severe asthma. *Am Rev Respir Dis* 1992; **146** (5 Pt 1): 1136–1142.

Key message

In patients with COPD or asthma undergoing mechanical ventilation, intrathoracic pressure may increase, and may have serious cardiovascular consequences. This ‘auto-PEEP’ is easily measured in ‘relaxed’ patients by specific maneuvers, but otherwise may go unrecognized.

Why it's important

The existence of auto-PEEP was undoubtedly recognized by some critical care physicians before publication of this commentary. However, the combination of well-chosen illustrative clinical cases, and a clear description of the mechanism of auto-PEEP and its consequences, measurement, and treatment, ensured its rapid acceptance into standard practice. This phenomenon provides the explanation for much of the mortality of mechanically-ventilated asthmatic patients; ventilatory strategies in obstructive diseases are hence based on this concept.

Relevance

Asthma and COPD represent a significant proportion of the patients undergoing mechanical ventilation, and the adoption of the principles outlined in this paper has undoubtedly saved many lives. Many modern ventilators have a means of measuring auto-PEEP automatically.

Title***Pressure-volume curve of total respiratory system in acute respiratory failure: computed tomographic scan study***

Author

Gattinoni L, Pesenti A, Avalli L, Rossi F, Bombino M

Reference*Am Rev Respir Dis* 1987; **136**: 730–736

Abstract

To investigate the relationship between lung anatomy and pulmonary mechanics in acute respiratory failure (ARF), 20 patients with ARF underwent computerized tomography (CT) at three levels of positive end-expiratory pressure (PEEP) (5, 10, and 15 cmH₂O). The static pressure-volume curve of the total respiratory system and the lung volumes (helium dilution method) were also measured. By knowing the lung volumes and analyzing the CT number frequency distribution, a quantitative estimate of normally aerated, poorly aerated, and nonaerated lung tissue was obtained at each level of PEEP. The recruitment was defined as the percent increase of normally aerated tissue from 5 to 15 cmH₂O. We found that the different compliances (starting compliance, inflation compliance, and deflation compliance) were correlated only with the amount of normally aerated tissue present in the range of pressures explored by a given compliance (5 cmH₂O for starting compliance, and 15 cmH₂O for inflation and deflation compliances). No relationship was found between the compliances and the poorly aerated and nonaerated tissue. The specific compliance was in the normal range, whereas the amount of recruitment was related to the ratio of inflation compliance to starting compliance. Our data suggest that (1) the pressure-volume curve parameters in ARF investigate only the residual healthy zones of the lung, and do not directly estimate the 'amount' of disease (poorly or nonaerated tissue), (2) the pressure-volume curve may allow an estimate of the anatomic recruitment, and (3) the residual normally aerated zones of the ARF lung seem to maintain a normal intrinsic elasticity.

Summary

Gattinoni's group in Milan used CT in ventilated patients with acute respiratory failure (ARF) to relate lung structure to function. An earlier study had shown that the distribution of abnormal lung in ARF was not uniform, occurring largely in dependent (an example of this is seen in [Figure 1-5](#)). In this study, the amount of normally aerated, regions poorly aerated, and nonaerated lung was calculated and related to the physiological parameters of the pressure-volume curve in 20 patients with ARF of diverse origins. The main findings were that the compliance of the lung was related only to the amount of normally aerated lung tissue, and that the specific compliance of these areas was normal. By correlating the appearance of the PV curve with the amounts of aerated lung derived from CT scanning, anatomical recruitment is evident.

Citation count

358

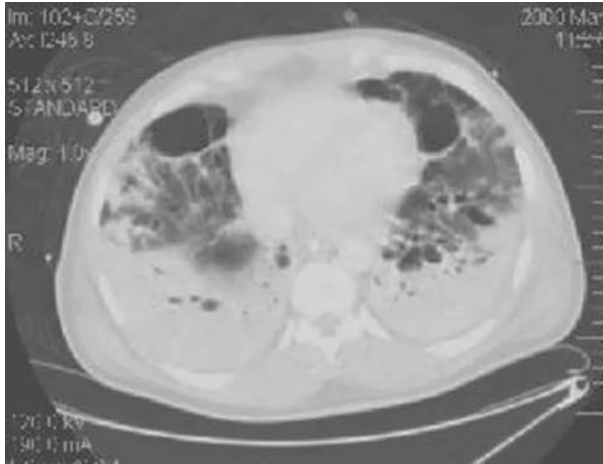

Fig. 1-5. A CT scan image of a patient with ARDS showing the marked heterogeneity of the disease process (courtesy of Dr T.E. Stewart).

Related references

1. Gattinoni L, Mascheroni D, Torresin A *et al*. Morphological response to positive end-expiratory pressure in acute respiratory failure. Computerized tomography study. *Intensive Care Med* 1986; **12**: 137–142.
2. Gattinoni L, D'Andrea L, Pelosi P, Vitale G, Pesenti A, Fumagalli R. Regional effects and mechanism of positive end-expiratory pressure in early adult respiratory distress syndrome. *JAMA* 1993; **269**: 2122–2127.
3. Matamis D, Lemaire F, Harf A, Brun-Buisson C, Ansquer JC, Atlan G. Total respiratory pressure-volume curves in the adult respiratory distress syndrome. *Chest* 1984; **86**: 58–66.

Key message

There is heterogeneous distribution of diseased lung in ventilated patients with ARF, with some areas retaining near-normal elasticity.

Why it's important

This technique of correlating physiological studies with anatomical data from CT scanning greatly advanced our understanding of the pathophysiology of patients with ARDS. Before these elegant studies, ARDS was thought to affect the lung homogeneously. The structural and functional heterogeneity of the lung tissue seen in ARDS poses a considerable problem in ventilation, since volumes and pressures that may recruit abnormal areas may damage healthy areas with normal compliance. This paper was part of a body of evidence that provided the rationale for lung protective strategies.

Strengths

This study provided major new insights into the pathophysiology of ARDS.

Relevance

The concept of the 'baby lung' – functionally small, and easily damaged – which came from these studies is central to how clinicians and researchers think of the lung in ARDS.

Title***High inflation pressure pulmonary edema: respective effects of high airway pressure, high tidal volume, and positive end-expiratory pressure***

Author

Dreyfuss D, Soler P, Basset G, Saumon G

Reference*Am Rev Respir Dis* 1988; **137**: 1159–1164

Abstract

The respective roles of high pressure and high tidal volume to promote high airway pressure pulmonary edema are unclear. Positive end-expiratory pressure (PEEP) was shown to reduce lung water content in this type of edema, but its possible effects on cellular lesions were not documented. We compared the consequences of normal tidal volume ventilation in mechanically-ventilated rats at a high airway pressure (HiP-LoV) with those of high tidal volume ventilation at a high (HiP-HiV) or low (LoP-HiV) airway pressure, and the effects of PEEP (10 cmH₂O) on both edema and lung ultrastructure. Pulmonary edema was assessed by extravascular lung water content, and microvascular permeability by the drug lung weight and the distribution space of 125I-labeled albumin. HiP-LoV rat lungs were not different from those of controls (7 cmH₂O peak pressure ventilation). By contrast, the lungs from the groups subjected to high volume ventilation had significant permeability type edema. This edema was more pronounced in LoP-HiV rats. It was markedly reduced by PEEP, which, in addition, preserved the normal ultrastructural aspect of the alveolar epithelium. This was in striking contrast to the diffuse damage usually encountered in this type of edema. To our knowledge, this constitutes the first example of a protective effect of PEEP during permeability edema.

Summary

Dreyfuss and colleagues used a rat model to dissect out the relative contributions of high tidal volume and high pressure, and the effect of positive end-expiratory pressure (PEEP) in ventilator-induced lung injury. The ventilation strategies employed included:

1. Low volume, low pressure – the control group.
2. Low volume, high pressure achieved by strapping the chest and abdomen of the animal with rubber bands.
3. High pressure (45 cmH₂O), high volume (around 40 ml/kg).
4. High pressure as in (3), but with the addition of 10 cmH₂O PEEP (tidal volume around 25 ml/kg).
5. High volume (around 44 ml/kg), low pressure achieved by using a negative pressure ventilator 'iron lung'.

They found that ventilation at high volume, whether by low or high pressure, caused alveolar edema and extensive diffuse alveolar damage with disruption of type I epithelial cells and some endothelial cells. In contrast, the lungs ventilated at high pressure but normal volume showed no increase in alveolar fluid, and were normal on light and electron microscopic examination. The addition of PEEP to the high volume/high pressure group attenuated the degree of pulmonary edema and completely prevented visible epithelial damage, and the histological changes were minimal.

Citation count

602

Related references

1. Bouhuys A. Physiology and musical instruments. *Nature* 1969; **221**: 1199–1204.
2. Sandhar BK, Niblett DJ, Argiras EP, Dunnill MS, Sykes MK. Effects of positive end-expiratory pressure on hyaline membrane formation in a rabbit model of the neonatal respiratory distress syndrome. *Intensive Care Med* 1988; **14**: 538–546.

Key message

Pulmonary edema and alveolar damage caused by mechanical ventilation are due to high inflation volume, and not airway pressure *per se*, and may be greatly attenuated by the addition of PEEP.

Why it's important

Although it would have been obvious to physiologists that absolute airway pressure is not in itself a cause of lung injury (trumpet players routinely reach airway pressures of 150 cmH₂O – see reference 1, above), this paper provided convincing data that it is the inflating volume and not the absolute pressure that causes damage.

Strengths

A conceptually simple experiment that answered fundamental questions.

Weaknesses

The inevitable reservation that observations made in small mammals may not apply to humans.

Relevance

Later clinical studies, such as those of Hickling and the ARDSnet (see below), were to confirm the clinical importance of high volume ventilation.

Title

Low mortality associated with low volume pressure limited ventilation with permissive hypercapnia in severe adult respiratory distress syndrome

Author

Hickling KG, Henderson SJ, Jackson R

Reference

Intensive Care Med 1990; **16**: 372–377

Abstract

Many animal studies have shown that high peak inspiratory pressures (PIP) during mechanical ventilation can induce acute lung injury with hyaline membranes. Since 1984, we have limited PIP in patients with ARDS by reducing tidal volume, allowing spontaneous breathing with SIMV, and disregarding hypercapnia. Since 1987, 50 patients with severe ARDS with a 'lung injury score' greater than or equal to 2.5 and a mean PaO₂/FiO₂ ratio of 94 were managed in this manner. The mean maximum PaCO₂ was 62 mmHg, the highest being 129 mmHg. The hospital mortality was significantly lower than that predicted by Apache II (16% vs. 39.6%, $\chi^2 = 11.64$, $p < 0.001$). Only one death was due to respiratory failure, caused by pneumocystis pneumonia. Ten patients had a 'ventilator score' greater than 80, which has previously predicted 100% mortality from respiratory failure. Only two died, neither from respiratory failure. There was no significant difference in lung injury score, ventilator score, PaO₂/FiO₂, or maximum PaCO₂ between survivors and nonsurvivors. We suggest that this ventilatory management may substantially reduce mortality in ARDS, particularly from respiratory failure.

Summary

This is a retrospective analysis of 70 cases of acute respiratory distress syndrome (ARDS) managed in a single intensive care unit in Christchurch, New Zealand. The unit had adopted a ventilatory strategy to limit the peak inspiratory pressure (PIP) to < 40 cmH₂O in all cases, and < 30 if feasible, reducing tidal volume as low as 5 ml/kg body weight. Arterial hypercapnia (up to 70 mmHg) and acidosis (as low as pH 7.02) were largely ignored. The ventilatory mode was synchronized intermittent mandatory ventilation, and high ventilatory rates were observed in some cases. Fluid replacement was described as 'generous'.

Fifty of the 70 cases identified were designated as having severe ARDS based on a lung injury score (LIS) of > 2.5 , as defined by described by Murray *et al.* (1).

The main results are summarized in [Table 1-1](#). The observed mortality in the severe ARDS group was 16% compared with a value of 40% predicted by APACHE II; this was only marginally affected when corrections were made for the respiratory acidosis. Outcome was also improved using a distinct scoring system – the ventilator score. Only two of 10 patients with a ventilator score of > 80 died, compared with 100% in the series of Smith and Gordon (2). Comparing survivors and nonsurvivors, there were no significant differences in indices of lung injury or gas exchange, and the reduction in mortality appears to be due to fewer non-pulmonary deaths.

Table 1-1. Summary of the main results of the study

Patient group	Number of patients	Observed hospital mortality	Predicted mortality (APACHE II)
All patients	70	18.6%	37.8%*
Severe ARDS (LIS >2.5)	50	16%	39.6%*

*p = <0.001.

Citation count 406

Related references

1. Murray JF, Matthay MA, Luce JM, Flick MR. An expanded definition of the adult respiratory distress syndrome. *Am Rev Respir Dis* 1988; **138**: 720–723.
2. Smith PE, Gordon IJ. An index to predict outcome in adult respiratory distress syndrome. *Intensive Care Med* 1986; **12**: 86–89.
3. Laffey JG, Kavanagh BP. Carbon dioxide and the critically ill – too little of a good thing? *Lancet* 1999; **354**: 1283–1286.

Key message

Limiting the inspiratory pressure and allowing hypercapnia ('permissive hypercapnia') can reduce the mortality of ventilated patients with ARDS.

Why it's important

This study gave weight to the animal studies on ventilator-induced lung injury. It encouraged many critical care units to adopt a pressure-limited ventilatory strategy for ARDS long before the more 'definitive' study of the ARDSnet discussed below.

Strengths

This was a novel approach to the ventilatory treatment of ARDS.

Weaknesses

This study did not have a control group; thus, it is not possible to determine whether the strategy used did in fact decrease mortality.

Relevance

The general principle of limiting pressure/volume in patients with ARDS enunciated in this article provided interesting human data supporting the concept that a lung protective strategy may be beneficial in ARDS patients.

Title***A prospective study of indexes predicting the outcome of trials of weaning from mechanical ventilation***

Author

Yang KL, Tobin MJ

Reference*N Engl J Med* 1991; **324**: 1445–1450

Abstract

BACKGROUND. The traditional predictors of the outcome of weaning from mechanical ventilation – minute ventilation (VE) and maximal inspiratory pressure (P_Imax) – are frequently inaccurate. We developed two new indexes: the first quantitates rapid shallow breathing as the ratio of respiratory frequency to tidal volume (f/VT), and the second is termed CROP, because it integrates thoracic compliance, respiratory rate, arterial oxygenation, and P_Imax. **METHODS.** The threshold values for each index that discriminated best between a successful and an unsuccessful outcome of weaning were determined in 36 patients, and the predictive accuracy of these values was then tested prospectively in an additional 64 patients. Sensitivity and specificity were calculated, and the data were also analyzed with receiver operating characteristic (ROC) curves, in which the proportions of true positive results and false positive results are plotted against each other for a number of threshold values of an index; the area under the curve reflects the accuracy of the index. **RESULTS.** Sensitivity was highest for P_Imax (1.00), followed closely by the f/VT ratio (0.97). Specificity was highest for the f/VT ratio (0.64) and lowest for P_Imax (0.11). The f/VT ratio was the best predictor of successful weaning, and P_Imax and the f/VT ratio were the best predictors of failure. The area under the ROC curve for the f/VT ratio (0.89) was larger than that under the curves for the CROP index (0.78, *p* < 0.05), P_Imax (0.61, *p* < 0.001), and VE (0.40, *p* < 0.001). **CONCLUSIONS.** Rapid shallow breathing, as reflected by the f/VT ratio, was the most accurate predictor of failure, and its absence the most accurate predictor of success, in weaning patients from mechanical ventilation.

Summary

An earlier study at the same center in Houston had shown that unsuccessful trials of weaning from mechanical ventilation were often associated with rapid shallow breathing (see reference 1). This study sought to investigate which indices obtained during a trial in which the patients breathed spontaneously were useful in predicting successful weaning and extubation. Several parameters were analyzed, including an index of rapid shallow breathing (f/VT ratio), various 'traditional' indicators of weaning success, such as maximum inspiratory pressure, and also the CROP index, derived from various measurements in an attempt to integrate gas exchange, respiratory drive, and neuromuscular reserve. The study was conducted in two stages. The first retrospective section analyzed data from 36 patients who had undergone a trial of weaning, and of whom 24 had been weaned successfully. The other 12 failed the trial, based on objective criteria, or required re-intubation within 24 hours. For each index, threshold values were determined which best discriminated between successful and non-successful weaning. In the second stage, these threshold values were applied prospectively in a further 64 patients to predict the success of weaning.

Overall, the f/VT ratio was the most reliable predictor of the outcome of weaning trials. The threshold value of 105 (breaths/minute/tidal volume in liters) can conveniently be 'rounded off' to 100 for application in clinical practice.

Citation count 313

Related references

1. Tobin MJ, Perez W, Guenther SM *et al.* The pattern of breathing during successful and unsuccessful trials of weaning from mechanical ventilation. *Am Rev Respir Dis* 1986; **134**: 1111–1118.
2. Ely EW, Baker AM, Dunagan DP *et al.* Effect on the duration of mechanical ventilation of identifying patients capable of breathing spontaneously. *N Engl J Med* 1996; **335**: 1864–1869.

Key message

An index of rapid, shallow, breathing, or more specifically an f/VT ratio (breaths per minute/tidal volume in liters), negatively predicts the likelihood of successfully weaning from mechanical ventilation.

Why it's important

The study provided useful information on the timing of weaning and extubation, which are crucial issues in all intensive care units. It is fortuitous that the most useful index of those studied, the f/VT ratio, is so simple to derive.

Strengths

The study was well carried out, and the study design was novel at the time for ventilation studies; the weaning index obtained from one group of patients was assessed *prospectively* in a second independent group of patients. The findings of the study are clear and easily applied to clinical practice; it set the stage for subsequent weaning studies.

Relevance

The work is relevant to both everyday clinical practice, applicable to whatever weaning strategy is employed, and to those seeking to understand the pathophysiology of weaning failure.

Title

Mechanical ventilation: American College of Chest Physicians' Consensus Conference

Author

Slutsky AS

Reference

Chest 1993; **104**: 1833–1859; *Intensive Care Med* 1994; **20**: 64–79 and 150–162;
Respir Care 1993; **38**: 1389–1414

Abstract

Not available

Summary

Within this section, this article is unique in the sense that it does not introduce new research or data. Instead, it is the summary of a meeting of experts within the field of mechanical ventilation of the critically ill, held in early 1993. The experts were drawn from different disciplines (anesthesiology, critical care, pulmonary medicine, surgery), and from several continents. The conference, and this article, attempted to synthesize the fields of physiology, research (basic, animal, and clinical), and clinical experience into recommendations for practice.

Ideal practice of mechanical ventilation in critical care is not clearly defined, and there is an imbalance of data. On the one hand, there is a wealth of physiological information, research in animals, and extensive clinical experience. Added to this are technological advances that allow detailed monitoring, and new modes of ventilation. On the other hand, at the time of the conference, there was a paucity of large randomized clinical trials addressing ventilation in critical care settings. Without these, one must extrapolate as best one can, and this is the basis and strength of the paper. It provided the physiological rationale, and summarized research in the field, offering specific recommendations where possible. In some areas, no specific recommendations could be made – notably the ideal method of weaning, and which mode of ventilation is best.

Among the most important principles highlighted:

1. The need for frequent reassessment of the ventilatory support in the critically ill patient.
2. The recognition that mechanical ventilation is associated with adverse consequences.
3. In order to minimize these adverse consequences, it is not necessarily desirable to restore certain parameters to the normal range (for instance, the high inflation pressures required to normalize the arterial CO₂ tension may be more harmful than the high CO₂ itself).
4. Alveolar over-distention is injurious. In an attempt to provide a quantitative guide, the consensus opinion was that plateau pressures should be limited to < 35 cmH₂O if there was no evidence of increased chest wall elastance. This was viewed as more important than limiting the partial pressure of inspired oxygen.
5. Clinicians should be aware of the existence, measurement, and treatment of dynamic hyperinflation (auto-PEEP), which can have serious cardiovascular consequences and can go unrecognized if not looked for (see the review of the paper by Pepe and Marini earlier in this chapter).
6. Although the qualitative effect of a manipulation of the ventilator may be predictable (for instance, increasing minute ventilation will usually decrease PaCO₂), the magnitude of change is not easily predicted in an individual patient.

7. Manipulation of a ventilator setting designed to improve one parameter may adversely affect another parameter. For instance, increasing PEEP may increase arterial oxygenation but simultaneously decrease cardiac output, such that total oxygen delivery is decreased.

Citation count 273

Related references

None

Why it's important

This article is important for two reasons. First, it provided recommendations for clinical practice. Second, and more important, it defined the state of the art of mechanical ventilation in the critically ill in 1993. It almost certainly helped to stimulate clinical research in areas such as lung protective ventilation and weaning. It was widely cited in later trials as a benchmark.

Strengths

Clear explanations of the physiological principles that underpin the use of mechanical ventilation.

Weaknesses

Many of the recommendations were not based on randomized clinical trials.

Relevance

The clinical relevance of the paper will diminish with new research. Of enduring value, however, are the detailed physiological background of mechanical ventilation, and the principle that the field benefits from an occasional review of this type.

Title***Noninvasive ventilation for acute exacerbations of chronic obstructive pulmonary disease***

Author

Brochard L, Mancebo J, Wysocki M, Lofaso F, Conti G, Rauss A, Simonneau G, Benito S, Gasparetto A, Lemaire F

Reference

N Engl J Med 1995; **333**: 817–822

Abstract

BACKGROUND. In patients with acute exacerbations of chronic obstructive pulmonary disease, noninvasive ventilation may be used in an attempt to avoid endotracheal intubation and complications associated with mechanical ventilation. **METHODS.** We conducted a prospective, randomized study comparing noninvasive pressure-support ventilation delivered through a face mask with standard treatment in patients admitted to five intensive care units over a 15-month period. **RESULTS.** A total of 85 patients were recruited from a larger group of 275 patients with chronic obstructive pulmonary disease admitted to the intensive care units in the same period. A total of 42 were randomly assigned to standard therapy, and 43 to noninvasive ventilation. The two groups had similar clinical characteristics on admission to the hospital. The use of noninvasive ventilation significantly reduced the need for endotracheal intubation (which was dictated by objective criteria): 11 of 43 patients (26 percent) in the noninvasive ventilation group were intubated, as compared with 31 of 42 (74 percent) in the standard treatment group ($p < 0.001$). In addition, the frequency of complications was significantly lower in the noninvasive ventilation group (16 percent vs. 48 percent, $p = 0.001$), and the mean (\pm SD) hospital stay was significantly shorter for patients receiving noninvasive ventilation (23 \pm 17 days vs. 35 \pm 33 days, $p = 0.005$). The in-hospital mortality rate was also significantly reduced, with noninvasive ventilation (4 of 43 patients, or 9 percent, in the noninvasive ventilation group died in the hospital, as compared with 12 of 42, or 29 percent, in the standard treatment group; $p = 0.02$). **CONCLUSIONS.** In selected patients with acute exacerbations of chronic obstructive pulmonary disease, noninvasive ventilation can reduce the need for endotracheal intubation, the length of the hospital stay, and the in-hospital mortality rate.

Summary

Between September 1990 and November 1991, 85 of 275 patients presenting to five hospitals in France, Italy, and Spain with severe acute exacerbations of chronic obstructive pulmonary disease (COPD) were randomized to receive either standard therapy alone, or standard therapy with periods of noninvasive ventilation (NIV). Pressure cycled NIV was delivered at an initial pressure of 20 cmH₂O via a full face mask for a minimum of only 6 hours per day. The need for intubation, dictated by established 'major' and 'minor' criteria, was the primary end-point.

Of 43 patients in the NIV group, 11 (26%) were intubated, compared with 31 of 42 (74%) in the standard therapy alone group. The majority of the intubations took place in the first 3 hours. Mortality was significantly lower in the NIV group (9% versus 29%), a difference explained by the need for intubation. The complication rate and hospital stay were also lower, suggesting an economic benefit.

Citation count

568

Related references

1. Bott J, Carroll MP, Conway JH *et al*. Randomised controlled trial of nasal ventilation in acute ventilatory failure due to chronic obstructive airways disease. *Lancet* 1993; **341**: 1555–1557.
2. Kramer N, Meyer TJ, Meharg J, Cece RD, Hill NS. Randomized, prospective trial of noninvasive positive pressure ventilation in acute respiratory failure. *Am J Respir Crit Care Med* 1995; **151**: 1799–1806.
3. Meduri GU, Abou-Shala N, Fox RC, Jones CB, Leeper KV, Wunderink RG. Noninvasive face mask mechanical ventilation in patients with acute hypercapnic respiratory failure. *Chest* 1991; **100**: 445–454.

Key message

The use of NIV in patients with exacerbations of COPD severe enough to be likely to need intubation leads to a reduction in the rate of intubation, and through this a reduced mortality and hospital stay.

Why it's important

This was the largest of the prospective randomized controlled trials for NIV in COPD, and the first to have shown a reduced mortality as well as reduced intubation rate.

Strengths

1. Relatively large patient group at five centers, with no important differences in outcome between the centers.

Weaknesses

1. The trial was, by the nature of the treatment, unblinded, introducing the possibility of bias. It is notable that the indication for intubation in the standard therapy group was based on major rather than minor criteria in 73%, compared with only 32% in the NIV group.
2. The mortality of 29% in the standard therapy group seems somewhat high, and it raises the possibility that the standard treatment was not optimum. For instance, only 60% of the patients received corticosteroids, which might be considered a usual treatment in severe COPD, although there are no large studies showing a mortality benefit with steroids in this patient group.

Relevance

NIV has become a standard treatment option in hospitals in many countries for severe exacerbations of COPD.

Title***Injurious ventilatory strategies increase cytokines and c-fos m-RNA expression in an isolated rat lung model***

Author

Tremblay L, Valenza F, Ribeiro SP, Li J, Slutsky AS

Reference*J Clin Invest* 1997; **99**: 944–952

Abstract

We examined the effect of ventilation strategy on lung inflammatory mediators in the presence and absence of a preexisting inflammatory stimulus. Fifty five Sprague-Dawley rats were randomized to either intravenous saline or lipopolysaccharide (LPS). After 50 minutes of spontaneous respiration, the lungs were excised and randomized to 2 hours of ventilation with one of four strategies: (a) control (C), tidal volume (V_t) = 7 cc/kg, positive end-expiratory pressure (PEEP) = 3 cmH₂O, (b) moderate volume, high PEEP (MVHP), V_t = 15 cc/kg, PEEP = 10 cmH₂O, (c) moderate volume, zero PEEP (MVZP), V_t = 15 cc/kg, PEEP = 0, or (d) high volume, zero PEEP (HVZP), V_t = 40 cc/kg, PEEP = 0. Ventilation with zero PEEP (MVZP, HVZP) resulted in significant reductions in lung compliance. Lung lavage levels of TNF α , IL-1 β , IL-6, IL-10, MIP-2, and IFN γ were measured by ELISA. Zero PEEP in combination with high volume ventilation (HVZP) had a synergistic effect on cytokine levels (e.g., 56-fold increase of TNF α versus controls). Identical end-inspiratory lung distention with PEEP (MVHP) resulted in only a three-fold increase in TNF α , whereas MVZP produced a six-fold increase in lavage TNF α . Northern blot analysis revealed a similar pattern (C, MVHP < MVZP < HVZP) for induction of c-fos mRNA. These data support the concept that mechanical ventilation can have a significant influence on the inflammatory/anti-inflammatory milieu of the lung, and thus may play a role in initiating or propagating a local, and possibly systemic, inflammatory response.

Summary

This study demonstrated that so-called ‘injurious ventilatory strategies’ of high tidal volume and no positive end-expiratory pressure (PEEP) cause the lung to increase production of various cytokines. The experimental model was relatively simple: excised, non-perfused rat lungs were ventilated for 2 hours with various combinations of tidal volume and PEEP, as detailed above. Although it clearly has its limitations, this model permits study of tidal volumes and end-expiratory pressures that would cause confounding cardiovascular compromise under in vivo conditions. Bronchoalveolar lavage (BAL) fluid was then collected, and inflammatory cytokines (TNF- α , IL-1 β), a chemokine (MIP-2), and an anti-inflammatory cytokine (IL-10) were assayed. BAL cytokines were higher from lungs ventilated without PEEP, and greatly increased in the group that received high tidal volume and no PEEP. Pre-treatment of the animals with LPS had minimal effect on most of these levels. Levels of mRNA for TNF- α and c-fos, an immediate response gene, were measured in whole lung extracts, and were also increased with the injurious strategies. However, the magnitude of the increase of TNF- α mRNA was much less than at the protein level, suggesting regulation at the post-transcriptional level.

Citation count

484

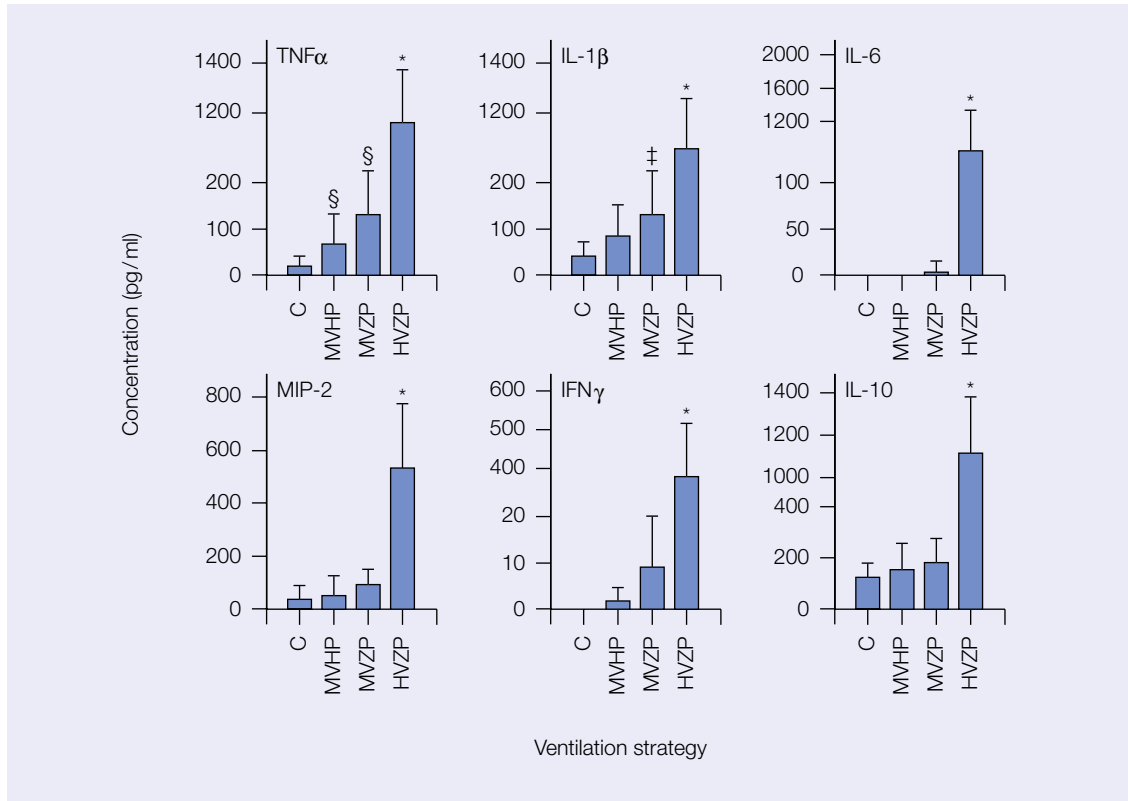

Fig. 1-6. Effect of ventilation strategy on absolute lung lavage cytokine concentrations for the saline-injected groups. A similar trend was seen for all cytokines with lowest levels in the control group (C) and highest in HVZP. Despite similar end-expiratory distention, MVHP ventilation had significantly lower BAL cytokine concentrations than HVZP ventilation * $p < 0.05$ vs control, MVHP, MVZP; † $p < 0.05$ vs control, MVHP; § $p < 0.05$ vs control

Related references

1. Chiumello D, Pristine G, Slutsky AS. Mechanical ventilation affects local and systemic cytokines in an animal model of acute respiratory distress syndrome. *Am J Respir Crit Care Med* 1999; **160**: 109–116.
2. Ranieri VM, Suter PM, Tortorella C *et al.* Effect of mechanical ventilation on inflammatory mediators in patients with acute respiratory distress syndrome: a randomized controlled trial. *JAMA* 1999; **282**: 54–61.
3. Slutsky AS, Tremblay LN. Multiple system organ failure. Is mechanical ventilation a contributing factor? *Am J Respir Crit Care Med* 1998; **157**: 1721–1725.

Key message

Ventilatory strategies of high tidal volume and zero PEEP can lead to release of inflammatory cytokines from lung tissue.

Why it's important

This is a key paper introducing the concept of 'biotrauma' into the field of mechanical ventilation. It raises the possibility that ventilation which over-distends the alveoli, or which causes repetitive opening and closing of the airways, causes release of factors that may contribute to distal organ failure.

Weaknesses

The experimental model uses excised, non-perfused lungs, which may behave very differently to in vivo conditions.

Relevance

Most of the mortality seen in ARDS is not directly attributable to respiratory failure. It is possible that future therapeutic benefits will be achieved by minimizing the release of systemically active inflammatory mediators from the lung undergoing mechanical ventilation.

Title

Ventilation with lower tidal volumes as compared with traditional tidal volumes for acute lung injury and the acute respiratory distress syndrome

Author

The Acute Respiratory Distress Syndrome Network

Reference

N Engl J Med 2000; **342**: 1301–1308

Abstract

Background. Traditional approaches to mechanical ventilation that use tidal volumes of 10 to 15 ml per kilogram of body weight may cause stretch-induced lung injury in patients with acute lung injury and the acute respiratory distress syndrome. We therefore conducted a trial to determine whether ventilation with lower tidal volumes would improve the clinical outcomes in these patients.

Methods. Patients with acute lung injury and the acute respiratory distress syndrome were enrolled in a multi-center, randomized trial. The trial compared traditional ventilation treatment, which involved an initial tidal volume of 12 ml per kilogram of predicted body weight and an airway pressure measured after a 0.5-second pause at the end of inspiration (plateau pressure) of 50 cm of water or less, with ventilation with a lower tidal volume, which involved an initial tidal volume of 6 ml per kilogram of predicted body weight, a plateau pressure of 30 cm of water or less. The first primary outcome was death before a patient was discharged home and was breathing without assistance. The second primary outcome was the number of days without ventilator use from day 1 to day 28.

Results. The trial was stopped after the enrollment of 861 patients because mortality was lower in the group treated with lower tidal volumes than in the group treated with traditional tidal volumes (31.0 percent vs. 39.8 percent, $p = 0.007$), and the number of days without ventilator use during the first 28 days after randomization was greater in this group (mean [\pm SD], 12 ± 11 vs. 10 ± 11 ; $p=0.007$). The mean tidal volumes on days 1 to 3 were 6.2 ± 0.8 and 11.8 ± 0.8 ml per kilogram of predicted body weight ($p < 0.001$), respectively, and the mean plateau pressures were 25 ± 6 and 33 ± 8 cm of water ($p < 0.001$), respectively.

Conclusions. In patients with acute lung injury and the acute respiratory distress syndrome, mechanical ventilation with a lower tidal volume than is traditionally used results in decreased mortality, and increases the number of days without ventilator use.

Summary

Intubated patients who were within 36 hours of fulfilling the three criteria of (1) a ratio of $PO_2:FiO_2$ of ≤ 300 , (2) bilateral pulmonary infiltrates on chest x-ray, and (3) no evidence of left atrial hypertension, were recruited in 10 American critical care centers. Patients were randomly assigned to receive either a 'traditional' ventilatory strategy (tidal volume 12 ml/kg predicted body weight and plateau pressure limited to 50 cmH₂O), or a low volume strategy (tidal volume 6 ml/kg and plateau pressure limited to 30 cmH₂O). Changes in PEEP were allowed to improve oxygenation, and the ventilator rate was increased and/or bicarbonate was administered to maintain pCO₂ and pH near the normal range.

In-hospital mortality in the low volume group was 31%, as opposed to 39.8% in the traditional group. Less striking, but still statistically significant, were more ventilator-free

days and more days free of non-pulmonary organ failure in the low volume group. Plasma IL-6 levels declined more rapidly in the low volume group, suggesting faster resolution of (lung) inflammation.

Citation count 1830

Related references

1. Hickling KG, Henderson SJ, Jackson R. Low mortality associated with low volume pressure limited ventilation with permissive hypercapnia in severe adult respiratory distress syndrome. *Intensive Care Med* 1990; **16**: 372–377.
2. Amato MB, Barbas CS, Medeiros DM *et al.* Effect of a protective-ventilation strategy on mortality in the acute respiratory distress syndrome. *N Engl J Med* 1998; **338**: 347–354.
3. Stewart TE, Meade MO, Cook DJ *et al.* Evaluation of a ventilation strategy to prevent barotrauma in patients at high risk for acute respiratory distress syndrome. Pressure- and Volume-Limited Ventilation Strategy Group. *N Engl J Med* 1998; **338**: 355–361.

Key message

The outcome of patients with the acute respiratory distress syndrome and acute lung injury is improved if ventilation is carried out using low tidal volumes (6 ml/kg predicted body weight), rather than more traditional tidal volumes of 12 ml/kg.

Why it's important

The potential benefits of low tidal volume ventilation had been suspected for many years, largely on the basis of animal studies such as those of Webb and Tierney and Dreyfuss *et al.* discussed above. The study of Hickling *et al.* above had shown benefit, but this was retrospective and uncontrolled, while later small randomized prospective studies gave conflicting results. The ARDSnet marshalled the necessary resources for this massive trial, and the results are unequivocal.

Strengths

1. Large (861 patients), multicenter trial.
2. Simple intervention strategy, and clear outcome benefit.

Weaknesses

1. By the nature of the treatment, the trial was not blinded.

Relevance

This is the only intervention in ARDS/ALI that has been shown to reduce mortality in a large, prospective, randomized trial. Furthermore, the strategy is simple and requires no extra equipment. The reduction in mortality from 40% to 31% represents a huge savings in terms of lives per year.

Lung injury

Timothy Evans and Julius Cranshaw

Introduction

Acute lung injury is a twentieth century disease. The successful resuscitation of the casualties of war provided medicine with an apparently new pulmonary condition that initially defied treatment. However, the description of acute respiratory distress in adults (ARDS) in 1967 as a clinicopathological syndrome with multiple triggers leading to common consequences paved the way for an explosion in clinical and scientific research.

Despite recent advances, the definition of ARDS has remained problematic. Clinical trials have been facilitated since the Consensus Conference definition emerged in 1994. However, epidemiological studies have been difficult because of the evolving definition of ARDS, the defining of clinical criteria for lesser degrees of acute lung injury (ALI), and the pitfalls of historical comparisons. Moreover, the data currently available reveal trends towards improved outcome for patients with ARDS, which complicate the evaluation of putative therapeutic interventions.

Uncovering the pathophysiology of acute pulmonary damage has added to the understanding of co-existent organ failure and placed lung injury in the context of the multiple organ dysfunction syndrome. Cellular and molecular initiators, propagators, and terminators of lung injury have been identified *in vitro* and *in vivo*. Further, epidemiological data have distinguished pulmonary expression of inflammatory mediators predicting the development of ALI and ARDS.

Although there has been an enormous increase in knowledge concerning ALI and ARDS, the promise of biochemical hypotheses has not been fulfilled in clinical experience. Trials of inhaled nitric oxide, antioxidants, surfactant, prostaglandin E1, anti-endotoxin antibodies, ketoconazole, corticosteroids, and non-steroidal anti-inflammatory drugs have so far failed to demonstrate an effect on mortality. This suggests that the idea that all patients respond in a uniform fashion to different insults to produce ALI and ARDS via common pathways is flawed.

By contrast, one of the most exciting developments has been the application of computerized tomographic (CT) scanning to patients with ARDS. This imaging technique has significantly advanced our understanding of the pathophysiology of ARDS, and how mechanical ventilation or patient positioning influence lung recruitment. Although the use of the prone position pre-dated CT descriptions of its effects, the efficacy and simplicity of this technique to improve oxygenation give it significant advantages. Papers presented here illustrate the use of CT in ALI, and practical experience of extracorporeal membrane oxygenation (ECMO) and prone ventilation.

The authors' choice of the following 10 papers relating to ALI and ARDS is personal. The papers are not necessarily the most cited nor the most influential. Some are seminal, and others rely heavily on previous work. However, our intention was to provide a wide spectrum of important topics in lung injury that hopefully will make it easier for the reader to access more literature.

Title

Interleukin-8 and development of adult respiratory distress syndrome in at-risk patient groups

Author

Donnelly SC, Strieter RM, Kunkel SL, Walz A, Robertson CR, Carter DC, Grant IS, Pollok AJ, Haslett C

Reference

Lancet 1993; **341**: 643–647

Abstract

Neutrophils have been implicated in the pathogenesis of the adult respiratory distress syndrome (ARDS). We have measured concentrations of the neutrophil attractant interleukin-8 in blood and bronchoalveolar lavage fluid (BAL) from patients at risk of ARDS. We studied 29 patients from three groups at risk of developing ARDS: multiple trauma (n = 16), perforated bowel (n = 6), and pancreatitis (n = 7). ARDS developed in seven of these patients. Interleukin-8 in BAL and blood samples taken on initial presentation was measured by a sandwich enzyme-linked immunosorbent assay. The mean BAL interleukin-8 concentration was significantly higher for the patients who subsequently progressed to ARDS than for the non-ARDS group (3.06 [SE 2.64] vs. 0.053 [0.010] ng/mL, p = 0.0006). There was no difference between the groups in plasma interleukin-8 (6.23 [2.60] vs. 5.12 [2.22] ng/mL, p = 0.31). Immunocytochemistry suggested that the alveolar macrophage is an important source of interleukin-8 at this early stage in ARDS development. This study provides evidence of a relation between the presence of interleukin-8 in early BAL samples and the development of ARDS. The early appearance of interleukin-8 in BAL of patients at risk of ARDS may be an important prognostic indicator for the development of the disorder, and reinforces the likely importance of neutrophils and the effects of their accumulation and activation in the pathogenesis of many cases of ARDS.

Summary

This paper explored the hypothesis that the cellular and biochemical composition of bronchoalveolar lavage (BAL) fluid immediately following an insult associated with the development of the acute respiratory distress syndrome (ARDS) might predict which patients would develop lung injury. BAL was carried out in 29 patients as soon as possible after they suffered multiple trauma, or diagnoses of perforated bowel or pancreatitis were established. BAL and serum concentrations of the neutrophil attractant interleukin (IL)-8 were measured. In the group of seven subjects who developed ARDS, mean BAL IL-8 concentrations were significantly higher than in those who did not develop the syndrome. Plasma IL-8 levels did not differ between the two groups.

Citation count 419

Related references

1. Donnelly SC, Strieter RM, Reid PT *et al.* The association between mortality rates and decreased concentrations of interleukin-10 and interleukin receptor antagonist in the lung fluids of patients with the adult respiratory distress syndrome. *Ann Intern Med* 1996; **125**: 191–196.

2. Doerschuk CM. Mechanisms of leukocyte sequestration in inflamed lungs. *Microcirculation* 2001; **8**: 71–88.
3. Martin TR. Lung cytokines in ARDS (Roger S Mitchell Lecture). *Chest* 1999; **116**: 2S–8S.

Key message

Established ARDS is an inflammatory process characterized by recruitment of neutrophils to the alveoli. High levels of the neutrophil attractant IL-8 in BAL fluid in patients at risk of developing ARDS seemed to predict development of the established syndrome.

Why it's important

This was the first investigation designed to look at markers predictive for the development of ARDS in an at-risk population, and demonstrated the rapidity with which high levels of chemoattractants can be produced (sampling took place a mean of 2 hours after the insult in the case of trauma victims). Second, the study concentrated on markers detectable in BAL – at the time this was a novel approach. The greater specificity of alveolar rather than serum markers was confirmed. Finally, although at the time IL-8 was putatively important in modulating neutrophil recruitment, this study demonstrated that the lung produced IL-8 locally and was involved in initiating the inflammatory process that leads to ARDS.

Strengths

1. Early sampling (lavage performed within a mean of 15.0 and 19.9 hours for the patients who did not and who did develop ARDS, respectively).
2. Tightly defined patient population in terms of onset of precipitating condition (trauma, pancreatitis, perforated viscus).
3. Focused attention on analyzing inflammatory mediator concentrations in lung rather than serum.

Weaknesses

1. Despite significant differences between patients progressing to ARDS and those who did not, in terms of BAL IL-8 concentrations, considerable overlap existed between groups.
2. No attempt to differentiate concentrations of IL-8 in BAL between different at-risk groups with a specific precipitating condition.

Relevance

By the time this paper was published, ARDS was established as a spectrum of lung injury developing in patients with a wide variety of serious medical and surgical conditions, only some of which involved the lung. Why some patients developed lung injury and others did not, was not clear. Moreover, although lavage neutrophilia was known to develop (and has subsequently been shown to be associated with a poor prognosis if persistent), the mechanisms underlying this process were not known. This paper focused attention on the lung and the inflammatory processes within it, and showed for the first time that neutrophil chemoattractants can be produced rapidly and in high concentrations within a very short period of the onset of the precipitating insult. Clinical science and investigation at its best.

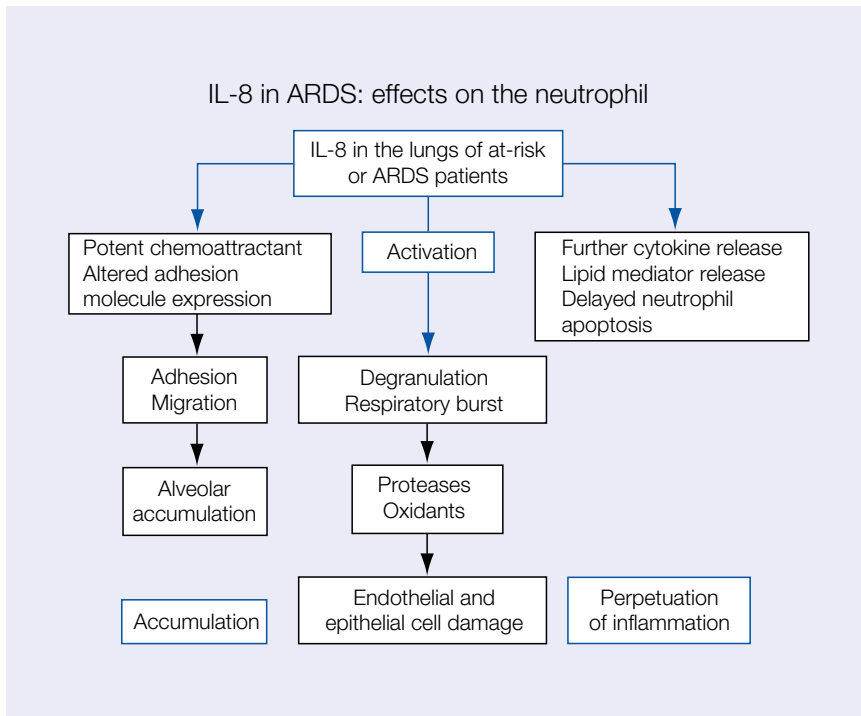

Fig. 2-1. *The pulmonary effects of IL-8*

Title***Inhaled nitric oxide for the adult respiratory distress syndrome***

Author

Rossaint R, Falke KJ, Lopez F, Slama K, Pison U, Zapol WM

Reference*N Engl J Med* 1993; **328**: 399–405

Abstract

BACKGROUND. The adult respiratory distress syndrome is characterized by pulmonary hypertension and right-to-left shunting of venous blood. We investigated whether inhaling nitric oxide gas would cause selective vasodilation of ventilated lung regions, thereby reducing pulmonary hypertension and improving gas exchange. **METHODS.** Nine of 10 consecutive patients with severe adult respiratory distress syndrome inhaled nitric oxide in two concentrations for 40 minutes each. Hemodynamic variables, gas exchange, and ventilation-perfusion distributions were measured by means of multiple inert gas elimination techniques during nitric oxide inhalation; the results were compared with those obtained during intravenous infusion of prostacyclin. Seven patients were treated with continuous inhalation of nitric oxide in a concentration of 5 to 20 parts per million (ppm) for 3 to 53 days. **RESULTS.** Inhalation of nitric oxide in a concentration of 18 ppm reduced the mean (\pm SE) pulmonary artery pressure from 37 \pm 3 mmHg to 30 \pm 2 mmHg ($p = 0.008$), and decreased intrapulmonary shunting from 36 \pm 5 percent to 31 \pm 5 percent ($p = 0.028$). The ratio of the partial pressure of arterial oxygen to the fraction of inspired oxygen ($\text{PaO}_2/\text{FiO}_2$), an index of the efficiency of arterial oxygenation, increased during nitric oxide administration from 152 \pm 15 mmHg to 199 \pm 23 mmHg ($p = 0.008$), although mean arterial pressure and cardiac output were unchanged. Infusion of prostacyclin reduced pulmonary artery pressure but increased intrapulmonary shunting and reduced the $\text{PaO}_2/\text{FiO}_2$ and systemic arterial pressure. Continuous nitric oxide inhalation consistently lowered the pulmonary artery pressure and augmented the $\text{PaO}_2/\text{FiO}_2$ for 3 to 53 days. **CONCLUSIONS.** Inhalation of nitric oxide by patients with severe adult respiratory distress syndrome reduces the pulmonary artery pressure and increases arterial oxygenation by improving the matching of ventilation with perfusion, without producing systemic vasodilation. Randomized, blinded trials will be required to determine whether inhaled nitric oxide will improve outcome.

Summary

The acute respiratory distress syndrome in adults (ARDS) is characterized by refractory hypoxemia attributable to increased intrapulmonary shunt and pulmonary hypertension, the extent and severity of which have adverse prognostic significance. The endogenous vasodilator nitric oxide (NO) was administered in two concentrations to nine patients with severe ARDS. Significant reductions in mean pulmonary artery pressure and intrapulmonary shunting were observed for the group as a whole. The ratio of the partial pressure of arterial oxygen to the fraction of inspired oxygen administered (an index of the efficacy of arterial oxygenation) increased significantly. No complications were observed, even in patients receiving inhaled NO for a prolonged period (up to 53 days).

Citation count

1087

Related references

1. Artigas A, Bernard GR, Carlet J *et al.* The American-European Consensus Conference on ARDS, part 2: Ventilatory, pharmacologic, supportive therapy, study design, strategies and issues related to recovery and remodelling; acute respiratory distress syndrome. *Am J Respir Crit Med* 1998; **157**: 1332–1347.
2. Dellinger RP, Zimmerman JL, Taylor RW *et al.* Effects of inhaled nitric oxide in patients with acute respiratory distress syndrome; results of a randomized phase II trial. Inhaled nitric oxide in ARDS Study. *Crit Care Med* 1998; **26**: 15–23.
3. Lundin S, Mang H, Smithies M *et al.* Inhalation of nitric oxide in acute lung injury: results of a European multicentre study. The European Study Group of Inhaled Nitric Oxide. *Intensive Care Med* 1999; **25**: 911–919.

Key message

Administration of a vasodilating agent via the inhaled route recruits blood flow in the injured lung away from damaged alveolar units to those that are normally ventilated, increasing blood perfusion to the latter. Not only was this shown to significantly improve pulmonary vascular resistance and shunting, but the resultant increase in arterial oxygenation was significant for the group as a whole, and clinically spectacular in one or two of the small number of patients studied.

Why it's important

NO was described as the molecule of the nineties, and as an ephemeral endogenously generated vasodilator (avidly bound to hemoglobin, and therefore inactivated by the time it reached the systemic circulation) which had effects confined to the pulmonary circulation. The spectacular effects shown in 60–70% of the patients studied by Rossaint *et al.* were far in excess of those that had been seen in this patient population using other therapies at the time. The authors were right to speculate that the effects of what has turned out to be a supportive therapy might not influence mortality, but at the time the data set provided the intensive care world with the first new and effective means of improving oxygenation in this patient population since the advent of effective mechanical ventilation.

Strengths

1. Scientifically adventurous: the first use of a potentially toxic inhaled substance in patients with severely damaged lungs.
2. Comparison of the effects with intravenous prostacyclin (wholly favorable to NO), the vasodilator of choice until this study was published.
3. Prolonged inhalation of NO in a subgroup of patients indicating that this advance represented a practical and apparently non-toxic supportive (and possibly therapeutic) intervention for ARDS.

Weaknesses

1. Small number of patients studied.
2. Wide range of response to inhaled NO concealed within abstracted data. Probably only 60% of the patients displayed a therapeutically useful response.

Relevance

This paper was a landmark study in introducing inhaled NO to the intensive care community. Although subsequent studies (see related references) showed that NO did not influence outcome, and it remains an unlicensed or off-label drug for ARDS, this paper opened up a whole new area of investigation in the critically ill patient, ranging from blockade of endogenous NOS production in sepsis, monitoring of exhaled NO in a variety of inflammatory lung conditions, and the use of the same agent as an intervention in patients with other forms of pulmonary hypertension, and with pediatric lung disease.

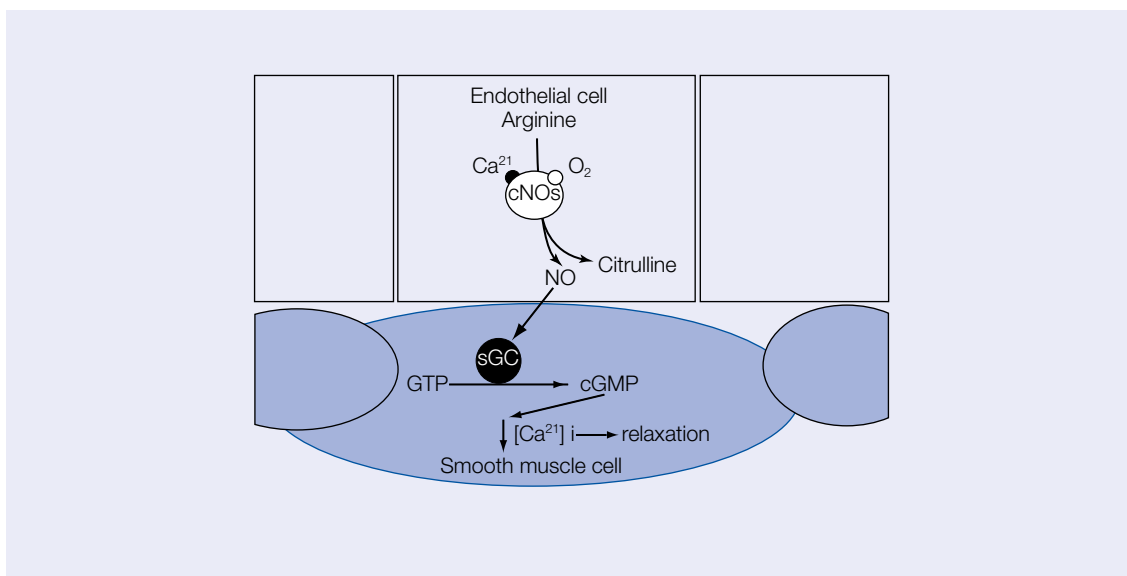

Fig. 2-2. The effect of inhaled NO on the pulmonary vasculature NO, nitric oxide; cNOS, constitutive nitric oxide synthase; sGC, soluble guanyl cyclase; GTP, guanosine triphosphate; cGMP, cyclic guanosine monophosphate

Title

Report of the American-European Consensus Conference on ARDS: definitions, mechanisms, relevant outcomes and clinical trial coordination

Author

Bernard R, Artigas A, Brigham KL, Carlet J, Falke K, Hudson L, Lamy M, LeGall JR, Morris A, Spragg R, The Consensus Committee

Reference

Intensive Care Med 1994; **20**: 225–232

J Crit Care 1994; **9**: 72–81

Am J Respir Crit Care Med 1994; **149** (3 Pt 1): 818–824

[Published erratum appears in *Am J Respir Crit Care Med* 1994; **149** (3 Pt 1): 838]

Abstract

The acute respiratory distress syndrome (ARDS), a process of nonhydrostatic pulmonary edema and hypoxemia associated with a variety of etiologies, carries a high morbidity rate, mortality rate (10% to 90%), and financial cost. The reported annual incidence in the United States is 150,000 cases, but this figure has been challenged and may be different in Europe. Part of the reason for these uncertainties is the heterogeneity of diseases underlying ARDS, and the lack of uniform definitions for ARDS. Thus, those who wish to know the true incidence and outcome of this clinical syndrome are stymied. The European American Consensus Committee on ARDS was formed to focus on these issues and on the pathophysiologic mechanisms of the process. It was felt that international coordination between North America and Europe in clinical studies of ARDS was becoming increasingly important to address the recent plethora of potential therapeutic agents for the treatment and prevention of ARDS.

Summary

The acute respiratory distress syndrome in adults (ARDS) was first described formally in 1967. Subsequent studies attempting to determine the incidence and outcome of ARDS were hampered by the heterogeneity and lack of definitions for the underlying disease processes, the lack of definition for ARDS itself, the non-uniformity of therapy, and the failure to define the population within which ARDS patients may be identified. This consensus conference attempted to redress this balance, making recommendations concerning the definitions of ARDS (and the less severe form of acute lung injury, ALI), identifying desirable characteristics for experimental studies investigating the pathophysiology of lung injury, identifying specific risk factors, prevalence, and outcome indices, and recommending mechanisms that might facilitate and promote the coordination of future clinical studies.

Citation count

1670

Related references

1. Abraham EA, Matthay MA, Dinarello CA *et al.* Consensus conference definitions for sepsis, septic shock, acute lung injury, and acute respiratory distress syndrome: time for a reevaluation. *Crit Care Med* 2000; **28**: 232–235.
2. Artigas A, Bernard GR, Carlet J *et al.* The American-European Consensus Conference on ARDS, part 2: Ventilatory, pharmacologic, supportive therapy, study design, strategies and issues related to recovery and remodelling; acute respiratory distress syndrome. *Am J Respir Crit Care Med* 1998; **157**: 1332–1347.
3. Schuster DP. What is acute lung injury? What is ARDS. *Chest* 1995; **107**: 1721–1726.

Key message

The publication of the findings of this North American-European consensus conference was an important landmark in ARDS research, bringing to what had hitherto been a disparate field a definition for the syndrome and lesser degrees of lung injury that has persisted and formed the foundation of many subsequent clinical studies.

Why it's important

Despite deficiencies in the original approach and recommendations (see below), the paper brought a degree of consensus and scientific uniformity that has benefitted this difficult field of research enormously. Subsequent consensus conferences are likely to modify the original definitions, but in an ordered and logical fashion, drawing upon lessons learned as a result of the original publication.

Strengths

1. Consensus from opinion leaders in both North America and Europe.
2. Broad terms of reference, including not only the definition for the syndrome (and ALI), but also making useful recommendations concerning the conduct of future research.
3. Introduction of a definition for ALI, emphasizing that ARDS probably represents only the extreme end of a spectrum of lung injury.

Weaknesses

The consensus did not define the circumstances in which the defining characteristics of ARDS may be elicited. Thus, the modes of support that need to be employed, and the duration of the abnormalities that define ARDS, were not discussed (or at least published).

Relevance

Outcome in ARDS depends in part upon the nature of the precipitating or underlying condition. This consensus attempted to define these conditions and their significance, and also brought consensus to the identification of the defining characteristics of the syndrome. Until the publication of this paper, clinical studies were characterized by inclusion of heterogeneous groups of patients, and variable and ill-defined clinical characteristics. Papers published subsequently have almost invariably used the consensus definition, enabling comparisons to be more usefully made between different publications. Despite this, the consensus definition badly needs an overhaul.

Title

Randomized clinical trial of pressure-controlled inverse ratio ventilation and extracorporeal CO₂ removal for adult respiratory distress syndrome

Author

Morris AH, Wallace CJ, Menlove RL, Clemmer TP, Orme JF, Weaver LK, Dean NC, Thomas F, East TD, Pace NL, Suchyta MR, Beck E, Bombino M, Sittig DF, Bohm S, Hoffman B, Becks H, Butler S, Pearl J, Rasmussen B

Reference

Am J Respir Crit Care Med 1994; **149**: 295–305

Abstract

The impact of a new therapy that includes pressure-controlled inverse ratio ventilation followed by extracorporeal CO₂ removal on the survival of patients with severe ARDS was evaluated in a randomized, controlled, clinical trial. Computerized protocols generated around-the-clock instructions for management of arterial oxygenation to assure equivalent intensity of care for patients randomized to the new therapy limb, and those randomized to the control, mechanical ventilation limb. We randomized 40 patients with severe ARDS who met the ECMO entry criteria. The main outcome measure was survival at 30 days after randomization. Survival was not significantly different in the 19 mechanical ventilation (42%) and 21 new therapy (extracorporeal) (33%) patients ($p = 0.8$). All deaths occurred within 30 days of randomization. Overall patient survival was 38% (15 of 40), and was about four times that expected from historical data ($p = 0.0002$). Extracorporeal treatment group survival was not significantly different from other published survival rates after extracorporeal CO₂ removal. Mechanical ventilation group survival was significantly higher than the 12% derived from published data ($p = 0.0001$). Protocols controlled care 86% of the time. Average PaO₂ was 59 mmHg in both treatment groups. Intensity of care required to maintain arterial oxygenation was similar in both groups (2.6 and 2.6 PEEP changes/day; 4.3 and 5.0 FIO₂ changes/day). We conclude that there was no significant difference in survival between the mechanical ventilation and the extracorporeal support as a therapy for ARDS. Extracorporeal support for ARDS should be restricted to controlled clinical trials.

Summary

The acute respiratory distress syndrome (ARDS) is characterized by pulmonary inflammation leading to increased alveolar capillary permeability. Mechanical ventilatory support may increase lung inflammation, and in the 1970s, interest in providing extracorporeal gas exchange, and thereby resting the injured lung, emerged. However, until this paper was published in 1994, no controlled trials comparing this onerous, expensive, and invasive approach with mechanical ventilation had been carried out. The authors showed that survival was not significantly different in 19 patients subjected to mechanical ventilation and 21 patients undergoing extracorporeal support for severe ARDS.

Citation count 258

Related references

1. Zapol WM, Snider MT, Hill JD *et al.* Extracorporeal membrane oxygenation in severe acute respiratory failure. *JAMA* 1979; **242**: 2193–2196.

- Gattinoni L, Pesenti A, Mascheroni D *et al*. Low frequency positive pressure ventilation with extracorporeal CO₂ removal in severe respiratory failure. *JAMA* 1986; **256**: 881–886.

Key message

In the controlled trial, patients with severe ARDS randomized between extracorporeal CO₂ removal and mechanical ventilatory support showed no difference in survival.

Why it's important

The provision of extracorporeal membrane oxygenation (ECMO) to rest the injured lung was emerging, particularly in European centers (see related references), as a powerful alternative to mechanical ventilation, even though no controlled trials had been carried out. This paper created considerable controversy by disproving this hypothesis, and the use of ECMO and related techniques has declined subsequently.

Strengths

- Randomized, controlled, clinical trial carried out in extremely difficult circumstances.
- Investigators carried out animal- and clinical-based learning curve procedures before embarking on the trial.
- The protocols controlled clinical care for 86% of the time, thereby removing effective confounding variables relating to subjective opinion as to how ECMO/mechanical ventilation should be best applied.

Weaknesses

- There was high mortality in both groups.
- However, in contrast to the expected mortalities used to power the trial, there was unexpectedly high survival in the conventional group, and unexpectedly low survival in the ECMO group. The trial was stopped early on the basis of the observed survival.

Relevance

The use of extracorporeal gas exchange to support patients with ARDS seemed logical, but was onerous and expensive, and could only be carried out in relatively few centers. This landmark study suggested that in adults, no survival advantage could be gained by using this approach.

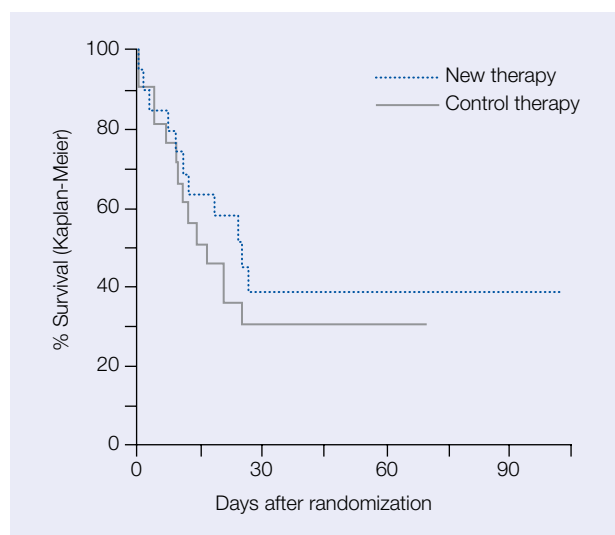

Fig. 2-3. Kaplan-Meier survival curves for the 19 control (traditional) therapy (solid line) and the 21 new therapy patients (dotted line)

Title

Improved survival of patients with acute respiratory distress syndrome (ARDS): 1983–1993

Author

Milberg JA, Davis DR, Steinberg KP, Hudson LD

Reference

JAMA 1995; **273**: 306–309

Abstract

OBJECTIVE – To analyze temporal trends in acute respiratory distress syndrome (ARDS) fatality rates since 1983 at one institution. **DESIGN** – Cohort. **SETTING** – Intensive care units of a large county hospital. **PATIENTS** – Consecutive adult patients (≥ 18 years of age) meeting ARDS criteria were identified through daily surveillance of intensive care units ($n = 918$ from 1983 through 1993). The major causes were sepsis syndrome in 37%, and major trauma in 25%; 37% had other risks. Sixty-five percent were male. The median age was 45 years (range, 18 to 92 years); 70% were younger than 60 years. **MAIN OUTCOME MEASURE** – Hospital mortality. **RESULTS** – Overall fatality rates showed no trend from 1983 to 1987, declined slightly in 1988 and 1989, and decreased to a low of 36% in 1993 (95% confidence interval, 25% to 46%). The crude rates were largely unchanged after adjustment for age, ARDS risk, and gender distribution. While patients both younger than 60 years, and 60 years or older, experienced declines in fatality rate, the larger decrease occurred in the younger cohort. In sepsis patients, ARDS fatality rates declined steadily, from 67% in 1990 to 40% in 1993 (95% confidence interval, 23% to 57%). The decline in sepsis-related ARDS fatality was confined largely to patients less than 60 years of age. Trauma patients and all other patients also experienced declines in fatality rates after 1987, although these trends were not as strong and consistent as in the sepsis population. **CONCLUSIONS** – In this large series, we observed a significant decrease in fatality rates occurring largely in patients younger than 60 years and in those with sepsis syndrome as their risk for ARDS. We are unable to determine the extent to which experimental therapies or other changes in treatment have contributed to the observed decline in the ARDS fatality rate. Institution-specific rates and temporal trends in ARDS fatality rates should be considered in clinical trials designed to prevent ARDS, and the high mortality associated with this syndrome.

Summary

The authors analyzed temporal trends in mortality attributable to the acute respiratory distress syndrome (ARDS) between 1983 and 1993 in a single institution. They observed no change in overall fatality rates from 1983 to 1987, a slight fall between 1988 and 1989, and a fall to a low of 36% in 1993. The decrease in fatality was attributable largely to the subset of patients younger than 60 years of age, and those with sepsis as a precipitating cause for their lung injury.

Citation count 372

Related references

1. Abel SJC, Finney SJ, Brett SJ, Keogh B, Morgan C, Evans T. Reduced mortality in association with the acute respiratory distress syndrome (ARDS). *Thorax* 1998; **53**: 292–294.

2. Villar J, Slutsky AS. The incidence of the adult respiratory distress syndrome. *Am Rev Respir Dis* 1989; **140**: 814–816.
3. Krafft P, Fridrich P, Pernerstorfer T *et al*. The acute respiratory distress syndrome; definitions, severity and clinical outcome – an analysis of 101 clinical investigations. *Intensive Care Med* 1997; **155**: 519–529.



Fig. 2-4. ARDS fatality rates Crude (solid line) and adjusted (dashed line) ARDS fatality rates, Harborview Medical Center, 1983–1993

Key message

Fatality rates in patients with ARDS may be falling. The only way this can be established clearly is by investigating institution-specific rates, which permit comparisons between different epochs in terms of severity of illness, case-mix, and therapeutic support systems.

Why it's important

Such data are highly relevant in designing clinical trials aimed at preventing ARDS, or the assessment of putative new therapeutic interventions.

Strengths

1. Large database (n = 918, 1983–1993)
2. Within-institution comparison

Weaknesses

1. Limited clinical information collected during the course of the ICU stay.
2. Authors unable to evaluate directly the role of specific treatment factors in improving patient outcome.

Relevance

Comparing fatality rates in published reports is impossible, in that institutions differ in their definitions and management of the syndrome and in their case-mix. Secondly, few or no studies have reported fatality rates over time. In this study, data were derived from one institution, the screening definition for ARDS remained unchanged, and the same personnel were responsible for data collection throughout the study. The authors were right to conclude that sample size and power calculations essential to the design of clinical trials for new interventions in ARDS must be based upon up-to-date, institution-specific fatality rates, and that such calculations should also account for patient age and clinical risk for ARDS. Using historical controls to evaluate the effects of new therapies is clearly no longer acceptable.

Title

Effect of prolonged methylprednisolone therapy in unresolving acute respiratory distress syndrome: a randomized controlled trial

Author

Meduri GU, Headley AS, Golden EM, Carson SJ, Umberger RA, Kelso T, Tolley EA

Reference

JAMA 1998; **280**: 159–165

Abstract

CONTEXT: No pharmacological therapeutic protocol has been found effective in modifying the clinical course of acute respiratory distress syndrome (ARDS), and mortality remains greater than 50%. OBJECTIVE: To determine the effects of prolonged methylprednisolone therapy on lung function and mortality in patients with unresolving ARDS. DESIGN: Randomized, double-blind, placebo-controlled trial. SETTING: Medical intensive care units of four medical centers. PARTICIPANTS: Twenty-four patients with severe ARDS who had failed to improve lung injury score (LIS) by the seventh day of respiratory failure. INTERVENTIONS: Sixteen patients received methylprednisolone, and 8 received placebo. Methylprednisolone dose was initially 2 mg/kg per day, and the duration of treatment was 32 days. Four patients whose LIS failed to improve by at least 1 point after 10 days of treatment were blindly crossed over to the alternative treatment. MAIN OUTCOME MEASURES: Primary outcome measures were improvement in lung function and mortality. Secondary outcome measures were improvement in multiple organ dysfunction syndrome (MODS), and development of nosocomial infections. RESULTS: Physiological characteristics at the onset of ARDS were similar in both groups. At study entry (day 9 [SD, 3] of ARDS), the 2 groups had similar LIS, ratios of PaO₂ to fraction of inspired oxygen (FIO₂), and MODS scores. Changes observed by study day 10 for methylprednisolone versus placebo were as follows: reduced LIS (mean [SEM], 1.7 [0.1] vs. 3.0 [0.2]; p<0.001); improved ratio of PaO₂ to FIO₂ (mean [SEM], 262 [19] vs. 148 [35]; p<0.001); decreased MODS score (mean [SEM], 0.7 [0.2] vs. 1.8 [0.3]; p<0.001); and successful extubation (7 vs. 0, p = 0.05). For the treatment group versus the placebo group, mortality associated with the intensive care unit was 0 (0%) of 16 vs. 5 (62%) of 8 (p = 0.002), and hospital-associated mortality was 2 (12%) of 16 vs. 5 (62%) of 8 (p = 0.03). The rate of infections per day of treatment was similar in both groups, and pneumonia was frequently detected in the absence of fever. CONCLUSIONS: In this study, prolonged administration of methylprednisolone in patients with unresolving ARDS was associated with improvement in lung injury and MODS scores, and reduced mortality.

Summary

The acute respiratory distress syndrome in adults is characterized by alveolar inflammation. No pharmacological therapeutic intervention has been shown to be effective in modifying the course of the condition. The authors evaluated the effects of prolonged methylprednisolone therapy on lung function and mortality in patients with unresolving ARDS. Secondary outcome measures were improvement in multiple organ dysfunction syndrome, and the development of nosocomial pneumonia. For those treated with methylprednisolone (2 mg/kg per day, 32 days) versus placebo, the lung injury score was significantly reduced, the ratio of PaO₂ to FIO₂ was significantly improved, and multiple organ dysfunction syndrome score and successful extubation were significantly reduced

and increased, respectively, in the actively treated group. Mortality associated with ICU stay for the groups was 0% versus 62%, respectively (hospital-associated mortality 12% versus 62%). The rate of infection per day of treatment was similar for both groups.

Citation count 254

Related references

1. Bernard GR, Luce JM, Sprung CL *et al*. High-dose corticosteroids in patients with the adult respiratory distress syndrome. *N Engl J Med* 1987; **317**: 1565–1570.
2. Artigas A, Bernard GR, Carlet J *et al*. The American-European Consensus Conference on ARDS, part 2: Ventilatory, pharmacologic, supportive therapy, study design, strategies and issues related to recovery and remodelling; acute respiratory distress syndrome. *Am J Respir Crit Care Med* 1998; **157**: 1332–1347.
3. Wheeler A, Bernard GR, Schoenfeld D, Steinberg K. Methylprednisolone for unresolving ARDS. *JAMA* 1998; **280**: 2074.

Key message

Meta-analyses of randomized trials investigating short courses of high-dose methylprednisolone in early sepsis and ARDS have found no evidence of beneficial effects. By contrast, this study indicated significant improvement in lung function during prolonged methylprednisolone administration in patients with unresolving ARDS from a variety of etiologies.

Why it's important

Steroids have long been considered to be contraindicated in patients with ARDS complicated by sepsis. Early trials administered the drug immediately after the onset of lung injury. In a condition characterized by ongoing inflammation (i.e. unresolving ARDS), steroids are likely to be effective, but it is clear that timing and duration of therapy are critical variables in determining therapeutic outcome.

Strengths

1. Selected patient population (unresolving ARDS, 7 days of ventilation with LIS ≥ 2.5 , and < 1 point reduction from day 1 of ARDS; no evidence of untreated infection).
2. Prolonged treatment with methylprednisolone.
3. Cross-over provision for patients who did not respond to the other treatment intervention.
4. Careful protocol for identifying infection including regular bronchoscopy.

Weaknesses

1. Little explanation of methodology.
2. CT or other radiological data would have strengthened the message.
3. Unusual randomization strategy and intention-to-treat analysis reduced, significance of results.
4. Few patients with this ARDS-related syndrome could be recruited, despite a long trial period.

Relevance

Theoretically, glucocorticoids have a number of important effects that may be of relevance in modulating the pathogenesis of sepsis in ARDS in terms of both lung and vascular inflammation. This investigation and recent data delineating the complex relationship between hypothalamic-pituitary-adrenal function, glucocorticoid receptor activity, and cytokine modulation of the host defense response in critical illness suggest that it is time for a reappraisal of the possible benefits of steroid therapy in ARDS and other critical illnesses.

Title

Aerosolized surfactant in adults with sepsis-induced acute respiratory distress syndrome

Author

Anzueto A, Baughman RP, Guntupalli KK, Weg JG, Wiedemann HP, Raventos AA, Lemaire F, Long W, Zaccardelli DS, Pattishall EN for the EXOSURF Acute Respiratory Distress Syndrome Sepsis Study Group

Reference

N Engl J Med 1996; **334**: 1417–1421

Abstract

BACKGROUND. Patients with acute respiratory distress syndrome (ARDS) have a deficiency of surfactant. Surfactant replacement improves physiologic function in such patients, and preliminary data suggest that it may improve survival. **METHODS.** We conducted a prospective, multi-center, double-blind, randomized, placebo-controlled trial involving 725 patients with sepsis-induced ARDS. Patients were stratified according to the risk of death at baseline (indicated by their score on the Acute Physiological and Chronic Health Evaluation [APACHE III] index), and randomly assigned to receive either continuously administered synthetic surfactant (13.5 mg of dipalmitoylphosphatidylcholine per milliliter, 364 patients) or placebo (0.45 percent saline; 361 patients) in aerosolized form for up to five days. **RESULTS.** The demographic and physiologic characteristics of the two treatment groups were similar at baseline. The mean (\pm SD) age was 50 \pm 17 years in the surfactant group, and 53 \pm 18 years in the placebo group, and the mean APACHE III scores at randomization were 70.4 \pm 25 and 70.5 \pm 25, respectively. Hemodynamic measures, measures of oxygenation, duration of mechanical ventilation, and length of stay in the intensive care unit did not differ significantly in the two groups. Survival at 30 days was 60 percent for both groups. Survival was similar in the groups when analyzed according to APACHE III score, cause of death, time of onset and severity of ARDS, presence or absence of documented sepsis, underlying disease, whether or not there was a do-not-resuscitate order, and medical center. Increased secretions were significantly more frequent in the surfactant group; the rates of other complications were similar in the two groups. **CONCLUSIONS.** The continuous administration of aerosolized synthetic surfactant to patients with sepsis-induced ARDS had no significant effect on 30-day survival, length of stay in the intensive care unit, duration of mechanical ventilation, or physiologic function.

Summary

Patients with acute respiratory distress syndrome (ARDS) are known to have abnormalities of surfactant production and metabolism. Surfactant replacement therapy is of proven benefit in infantile respiratory distress syndrome. This study demonstrated that in adult patients with sepsis-induced ARDS, synthetic surfactant administered in aerosolized form continuously for up to 5 days had no influence on 30-day survival; nor upon length of stay in the intensive care unit (ICU), duration of mechanical ventilation, or physiological function.

Citation count

258

Related references

1. Horbar JD, Soll RF, Sutherland JM *et al*. A multicenter randomized, placebo-controlled trial of surfactant therapy for respiratory distress syndrome. *N Engl J Med* 1989; **320**: 959–965.
2. Baker CS, Evans TW, Randle BJ, Haslam PL. Damage to surfactant-specific protein in acute respiratory distress syndrome. *Lancet* 1999; **353**: 1232–1237.
3. Hamm H, Fabel H, Bartsch W. The surfactant system of the adult lung: physiology and clinical perspectives. *Clin Invest* 1992; **70**: 637–657.

Key message

The continuous administration of aerosolized synthetic surfactant to patients with sepsis-induced ARDS has no significant effect on 30-day survival, length of stay in the ICU, duration of mechanical ventilation, or physiological function.

Why it's important

In the earliest significant reference to ARDS (*Lancet* 1967; 2: 319–323), the authors speculated following histological examination of post-mortem lung specimens that surfactant deficiency might be relevant to the pathogenesis of the syndrome. Subsequently, the infantile respiratory distress syndrome in premature neonates was found to be directly attributable to inadequate surfactant production. Early investigations of the composition and biophysical activity of surfactant in ARDS (*J Clin Invest* 1991; 88: 1976–1981) suggested that alveolar inflammation might lead to changes in surfactant composition, with direct implications for the abnormalities in lung mechanics that characterize the syndrome. Others speculated that surfactant might have immunomodulatory capacities potentially beneficial to patients with sepsis-induced ARDS. This study was important in assessing this hypothesis in a formal fashion in over 700 patients, carefully stratified and randomly assigned to receive either continuously administered surfactant or placebo.

Strengths

1. Careful study design.
2. Rational basis for the use of surfactant in these circumstances.
3. Development of specific technology for continuous administration of surfactant.
4. Employed a product of proven benefit to neonates with neonatal respiratory distress syndrome.

Weaknesses

1. Synthetic surfactant did not contain apoproteins subsequently shown to be damaged in ARDS, and possibly important for an immunomodulatory role.
2. The device designed to continuously administer surfactant may have been inadequate.
3. The assessment of adequate surfactant delivery and dose response were poorly characterized.
4. The primary cause of death in ARDS is frequently not respiratory. In these circumstances, using mortality as a primary end-point was probably ill advised. The use of artificial surfactants purely as adjuncts to mechanical ventilation might have been more rational than trying to reduce mortality.

Relevance

This study represents an important contribution to the ARDS literature for several reasons. First, the rationale for supplementing alveolar surfactants was soundly based upon histopathological studies in post-mortem lung specimens and the examination of bronchoalveolar fluid from these patients. Second, even if mortality remained unaltered, the putative protective effects and mechanical advantage offered by surfactant are theoretically highly attractive in patients requiring rigorous mechanical ventilation. In contrast, the trial designers were, however, naive in assuming that mortality could be reduced given that the majority of patients with ARDS do not die a respiratory death. Moreover, they were looking at the subpopulation of patients with sepsis-induced lung injury, presumably on the assumption that surfactant might have immunomodulatory or antibacterial capacities. This was always going to be unlikely with a synthetic product, where the apoproteins (subsequently shown to be highly relevant in this context) were absent.

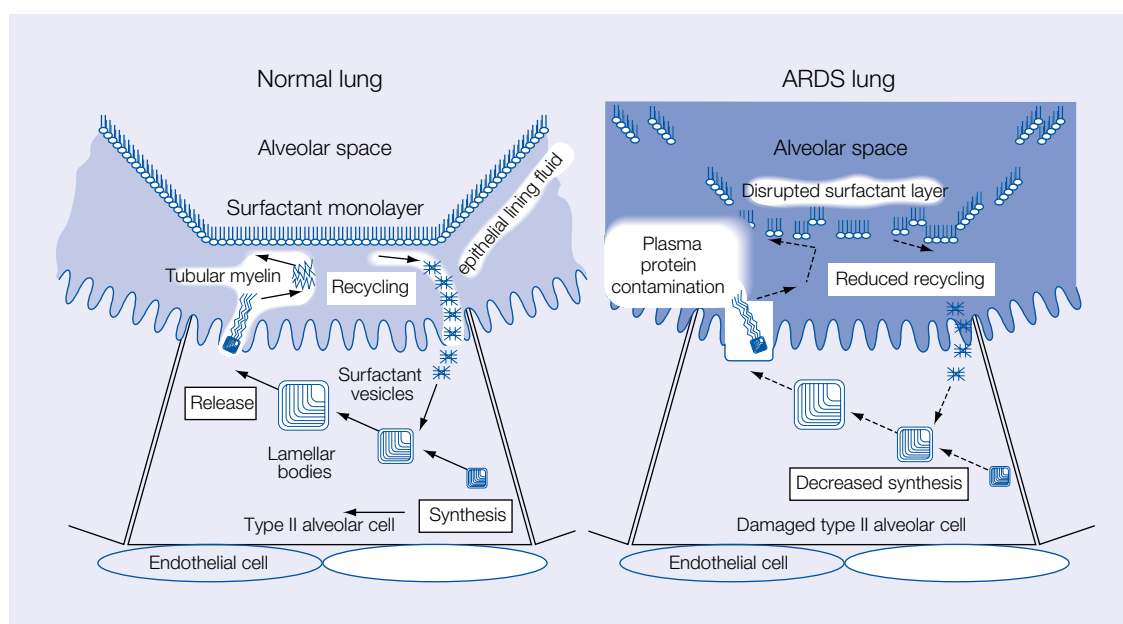

Fig. 2-5. *Surfactant in ARDS. Pre-existing surfactant is disrupted by plasma proteins leaking from pulmonary capillaries in ARDS, but the failure of type II alveolar cells is progressively more important. These cells synthesize, secrete, and recycle surfactant components to maintain alveolar levels*

Title***Relationships between lung computed tomographic density, gas exchange and PEEP in acute respiratory failure***

Author

Gattinoni L, Pesenti A, Bombino M, Baglioni S, Rivolta M, Rossi F, Rossi G, Fumagalli R, Marcolin R, Mascheroni D, Torresin A

Reference

Anesthesiology 1988; **69**: 824–832

Abstract

Twenty-two patients with acute respiratory failure underwent lung computed tomography (CT) and physiological measurements at 5, 10, and 15 cmH₂O positive end-expiratory pressure (PEEP) to investigate the relationship between morphology and function. Lung densities were primarily concentrated in the dependent regions. From the frequency distribution of CT numbers (difference in x-ray attenuation between water and lung) and lung gas volume measurements, the authors obtained a quantitative estimate of normally inflated, poorly inflated, and non-inflated lung tissue weight. This estimated average lung weight was increased two-fold above normal, and excess lung weight correlated with the mean pulmonary artery pressure ($p < 0.01$). Venous admixture correlated with the non-inflated tissue mass ($p < 0.01$). Increasing PEEP caused progressive clearing of radiographic densities and increased the mass of normally inflated tissue (anatomic recruitment), while reducing venous admixture. The cardiac index decreased after increasing PEEP, while oxygen delivery was unchanged. The authors conclude that CT scan lung density and oxygen exchange efficiency are correlated: the main effect of augmenting PEEP is to recruit perfused alveolar units that were previously collapsed.

Summary

Patients with ARDS requiring mechanical ventilation underwent lung computed tomography, while positive end-expiratory pressure (PEEP) was applied progressively, in order to investigate lung structure–function relationships. Increased lung density was primarily observed in the dependent regions. The extent of lung density correlated with gas exchange. Augmenting PEEP seemed to recruit perfused alveolar units that were previously collapsed.

Citation count

280

Related references

1. Gattinoni L, Bombino M, Pelosi P *et al.* Lung structure and function in different stages of the severe adult respiratory distress syndrome. *JAMA* 1994; **271**: 1772–1779.
2. Gattinoni L, D'Andrea L, Pelosi P, Vitale G, Pesenti A, Fumagalli R. Regional effects and mechanism of positive end-expiratory pressure in early adult respiratory distress syndrome. *JAMA* 1993; **269**: 2122–2127.
3. Goodman LR, Fumagalli R, Tagliabue P *et al.* Adult respiratory distress syndrome due to pulmonary and extrapulmonary causes: CT, clinical, and functional correlations. *Radiology* 1999; **213**: 545–552.
4. Gattinoni L, Caironi P, Pelosi P *et al.* What has computed tomography taught us about the acute respiratory distress syndrome? *Am J Respir Crit Care Med* 2001; **164**: 1701–1711.

Key message

This study confirmed that the high permeability pulmonary edema that characterizes ARDS is gravitationally distributed, and that the degree of venous admixture correlates with the anatomical extent of this non-inflated tissue mass. The authors showed that recruitment of these areas was possible by increasing the level of PEEP. This reduced venous admixture and cardiac index, but overall oxygen delivery was unchanged.

Why it's important

This paper was one of the first of a series by the same group to employ computed tomography in patients with severe ARDS, not only to characterize more specifically the radiographic appearances of the syndrome, but also to assess the effects of changing ventilatory parameters on the anatomy (and physiology) of the injured lung.

Strengths

1. This paper showed that CT could be used safely in patients with ARDS to investigate the mechanisms responsible for alterations in gas exchange following the application of PEEP.
2. The study paved the way for more sophisticated CT-based investigations in patients with ARDS both acutely and in convalescence (Acute respiratory distress syndrome: CT abnormalities at long-term follow-up. *Radiology* 1999; **210**: 29–35).
3. The authors showed that the application of PEEP improves anatomic recruitment leading to increased efficiency of gas exchange.

Weaknesses

1. The control population was composed of healthy individuals. It might have been more appropriate to use patients with critical illness requiring mechanical ventilatory support without complications of severe lung injury.
2. The patient population was heterogeneous, incorporating patients with lung injury attributable to direct pulmonary insults (e.g. pneumonia), and other, more distant, insults (e.g. peritonitis, pancreatitis). Subsequent studies from the same group have shown that the physiological responses to augmented ventilation differ in patients with ARDS associated with pulmonary and non-pulmonary insults (see *Am J Respir Crit Care Med* 1998; **158**: 3–11).

Relevance

Computed tomography is now an established investigative tool for patients with pulmonary pathology of all types, and has assisted in delineating the extent, severity, and therapeutic responsiveness of patients with both airway and interstitial pathology. However, the studies from this Italian group expanded the use of CT into patients with critical illness complicated by the most severe forms of acute respiratory distress. Specific patterns of lung injury were identified, but, more importantly, CT was able to delineate more precisely the effects of changing the patterns of mechanical ventilation used to support these patients. The study cited here established that PEEP can recruit unventilated but perfused alveoli, thereby improving gas exchange. Subsequent investigations from the same group suggested that this relationship is more complex. Thus, in certain circumstances, PEEP merely hyper-expands alveolar units that are already ventilated, rather than recruiting those obliterated by the inflammatory process. Secondly, the response of patients with ARDS to supportive techniques such as the application of end-expiratory pressure may vary according to the nature of the precipitating condition for ARDS. Thus, patients with direct pulmonary insults appear to be less recruitable than those suffering from lung injury in association with a more distant insult.

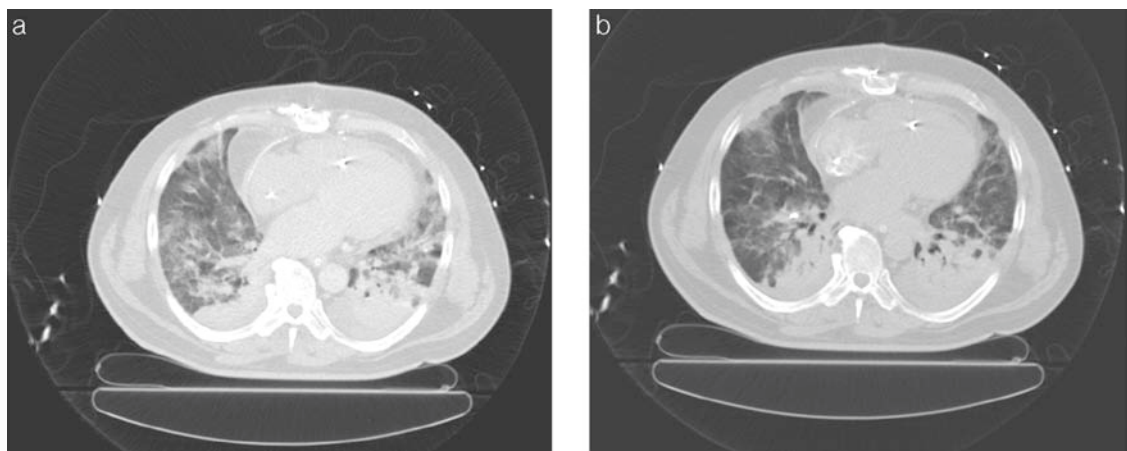

Fig. 2-6. *The effect of PEEP: (a) ARDS 5 cm PEEP; (b) ARDS 15 cm PEEP*

Title

Prone position in mechanically ventilated patients with severe acute respiratory failure

Author

Chatte G, Sab J-M, Dubois J-M, Sirodot M, Gaussorgues P, Robert D

Reference

Am J Respir Crit Care Med 1997; **155**: 473–478

Abstract

The purpose of this study was to characterize changes in oxygenation, expressed as $\text{PaO}_2/\text{FiO}_2$, when patients with severe acute respiratory failure ($\text{PaO}_2/\text{FiO}_2 < 150$), unrelated to left ventricular failure to atelectasis, were turned to and from a supine to prone position at 1- and 4 hour intervals. Ventilator settings were unchanged. Thirty-two consecutive patients were studied 1 hour before, 1 and 4 hour during, and 1 hour after placing in a prone position with $\text{PaO}_2/\text{FiO}_2$ of 103 ± 28 , 158 ± 62 , 159 ± 59 , and 128 ± 52 , respectively (ANOVA, $p < 0.001$). After 1 hour in a prone position, improvement of $\text{PaO}_2/\text{FiO}_2$ by 20 mm Hg or more was considered a positive response. Seven patients studied had no response (22%), hereafter referred to as nonresponders, and 25 had a positive response (78%), hereafter referred to as responders. Among the seven nonresponders, two did not tolerate the prone position and were returned supine before the end of the 4 hour trial. With the remaining five, $\text{PaO}_2/\text{FiO}_2$ evolution was 83 ± 29 , 77 ± 33 , and 81 ± 47 , respectively. For two of the 25 responders, measurements are missing after returning to the supine position. In 10 of the 23 responders (43%) who completed the 4 hour prone trial, the $\text{PaO}_2/\text{FiO}_2$ returned to its starting value when patients were repositioned supine: 117 ± 24 , 164 ± 44 , 156 ± 55 , and 110 ± 34 , respectively (ANOVA, $p < 0.001$). In 13 of the 23 (57%) improvement persisted: 105 ± 27 , 187 ± 58 , 189 ± 49 , and 157 ± 49 , respectively (ANOVA, $p < 0.001$). Repeated improvements after turning to a prone position were frequently observed. Side effects in the 32 patients after a total of 294 periods in a prone position included minor skin injury and edema, two instances of apical atelectasis, one catheter removal, one catheter compression, one extubation, and one transient supraventricular tachycardia.

Summary

This study demonstrated the changes in oxygenation when 32 patients with ARDS were turned from the supine to prone position for 4 hours. The $\text{PaO}_2/\text{FiO}_2$ rose >20 mmHg, often in minutes, in the majority of patients. In half of these, the improvement lasted more than 1 hour after returning supine. This persistent elevation in PaO_2 was associated with a higher rise in PaO_2 after prone positioning. There was no significant change in PaCO_2 nor hemodynamic values when prone. However, the initial FiO_2 and PEEP were lower in patients that responded well to turning (7.9 ± 4.3 versus 13.1 ± 5 cmH_2O), and thus they may have had less severe lung injury. Only two patients became worse when prone, but four had no improvement in oxygenation. The paper defined intolerance of the prone position as a fall in pulse oximetry of 5%, systolic blood pressure fall >25 mmHg, and acute arrhythmia. The authors also described their overall experience of prone ventilation. Thirteen of 32 patients were prone for $>10\%$ and 7 for $>20\%$ of their total ventilation time. Complications included frequent and abundant mobilization of secretions, dependent edema with cutaneous

and mucosal damage affecting anterior chest wall, lips, tongue, and forehead, unintentional extubation, and intravascular catheter removal with hemorrhage, arrhythmias, and line occlusions. No deaths were related to repositioning. Special beds and equipment were unnecessary, but planning, organization, and well-trained staff were considered essential. The authors did not claim an improved survival using the prone position, but this method of improving oxygenation was more practical and less invasive and expensive than extracorporeal membrane oxygenation and intravenous oxygenation devices, and pre-dated the use of inhaled vasodilators by some years.

Citation count 166

Related references

1. Langer M, Mascheroni D, Marcolin R, Gattinoni L. The prone position in ARDS patients. A clinical study. *Chest* 1988; **94**: 103–107.
2. Pappert D, Rossaint R, Slama K, Gruning T, Falke KJ. Influence of positioning on ventilation-perfusion relationships in severe adult respiratory distress syndrome. *Chest* 1994; **106**: 1511–1516.
3. Bryan AC. Comments of a devil's advocate. *Am Rev Respir Dis* 1974; **110**: 143–144.
4. Gattinoni L, Tognoni G, Pesenti A *et al*. Effect of prone positioning on the survival of patients with acute respiratory failure. *N Engl J Med* 2001; **345**: 568–573.

Key message

The strategy of repeatedly turning patients with acute lung injury to the prone position for several hours to improve oxygenation is frequently successful, and its effect may persist after the patient has been returned. However, placing a patient prone is not without risks.

Why it's important

This paper provided experience from an intensive care unit that practiced prone positioning over 14 months, and effectively integrated the shorter reports that emerged around this time. It described what to expect over the short and long term, and illustrated the risks and benefits of attempting to improve oxygenation by prone positioning in a relatively large series of patients. Complications and failures were detailed.

Strengths

1. There was a well-organized system for turning patients prone without extra equipment.
2. Ventilators were optimized by guidelines in paralyzed and sedated patients.
3. Ventilator settings were maintained, and FiO₂ was reduced to compare prone to supine positions.
4. There was a heterogeneous patient group.
5. Recent abdominal, thoracic, or cranial surgery was not a contraindication to turning prone.

Weaknesses

1. The success rate of turning prone in the long term was not stated.
2. There was no explanation or discussion as to why prone positioning failed in some patients.

3. Published in 1997, the data were gathered between 1992 and 1993 before the Consensus Conference definition of ARDS. Entry criteria were incomplete, and bias may be present.
4. Seventy five percent of patients had pulmonary infection as well as ARDS.
5. The authors hypothesized that PEEP and high FiO₂ damaged the lung, but used PIPs of 45 cmH₂O and TVs of approximately 10 ml/kg body mass, which is now known to be associated with less favorable outcome in patients with ARDS. (Ventilation with lower tidal volumes as compared to traditional tidal volumes for acute lung injury and the acute respiratory distress syndrome. The Acute Respiratory Distress Syndrome Network. *N Engl J Med* 2000; **342**: 1301–1308.)
6. A case for prone ventilation as 'protective' to the injured lung could not be established.

Relevance

Several studies since the 1970s with small numbers of patients described mixed results with the prone position in ARDS. This study demonstrated a clear and immediate success rate in clinical practice, with a persistent response in some patients. Initial improvement occurred rapidly, but defining a persistent response took hours. Other studies suggested reasons for this pattern of improvement. The caudal movement of the dorsal diaphragm in man is responsible for the dominant portion of the tidal volume. In CT scans, it is the lung cranial to this more curved diaphragmatic segment that is inflated in the prone position. Abdominal pressure and the mass of the heart also interfere with ventilation of this region in the supine position. Facilitating free abdominal expansion was an important part of obtaining better results in this study. Multiple inert gas elimination also indicates that dead-space ventilation significantly decreases when patients with acute lung injury (ALI) are turned prone. The persistent improvement in oxygenation after turning supine was attributed to lung recruitment and maintenance above airway and alveolar closing pressure. Although the authors did not state it, another advantage of prone ventilation may therefore be the alveolar and airway stability reducing the risk of injury during repetitive opening and closing. Prone positioning, although more cumbersome and labor intensive, may have theoretical benefits that make it preferable to inhaled vasodilators as well.

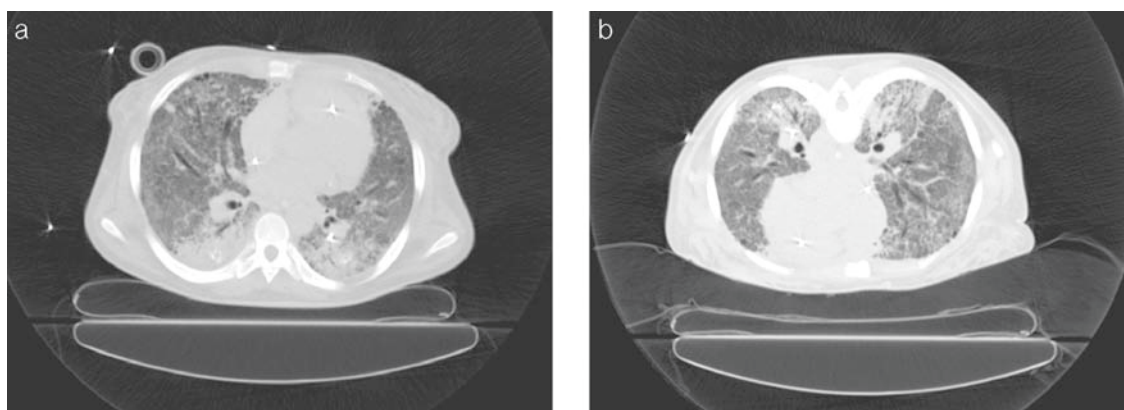

Fig. 2-7. The effect of turning Prone (a) supine; (b) Prone

Title

Acute respiratory distress in adults

Author

Ashbaugh DG, Bigelow DB, Petty TL, Levine BE

Reference

Lancet 1967; **2**: 319–323

Abstract

Not available

Summary

The respiratory distress syndrome in 12 patients was manifested by acute onset of tachypnea, hypoxemia, and loss of compliance after a variety of stimuli; the syndrome did not respond to usual and ordinary methods of respiratory therapy. The clinical and pathological features closely resembled those seen in infants with respiratory distress, and the conditions in congestive atelectasis and postperfusion lung. The theoretical relationship of this syndrome to alveolar pressure surface active agent is postulated. Positive end-expiratory pressure was most helpful in combating atelectasis and hypoxemia. Corticosteroids appeared to have value in the treatment of patients with fat embolism, and possibly viral pneumonia.

Citation count 1281

Related references

1. Petty TL, Ashbaugh DG. The adult respiratory distress syndrome: clinical features, factors influencing prognosis and principles of management. *Chest* 1971; **60**: 233–239.
2. Petty TL. Adult respiratory distress syndrome. Definition and historical perspective. *Clinics Chest Med* 1982; **3**: 3–7.
3. Bernard R, Artigas A, Brigham KL *et al*. The Consensus Committee. Report of the American-European consensus conference on ARDS: definitions, mechanisms, relevant outcomes and clinical trial coordination. *Intensive Care Med* 1994; **20**: 225–232.

Key message

The authors argued that a common clinicopathological syndrome caused by acute lung injury existed regardless of etiology. Clinically, the pulmonary response to injury induced severe dyspnea, tachypnea, and hypoxemia refractory to oxygen therapy, and reduced lung compliance. Pathologically, the acute insult resulted in the formation of hyaline membranes as had been seen in neonatal respiratory distress syndrome. Later, the damage either resolved or progressed to fibrosis. Chest radiographs confirmed these findings.

Why it's important

This paper is considered to contain the original description of 'acute respiratory distress', although undoubtedly patients with ALI had been described before by other authors. A final common path of lung injury with predictable clinical and pathological outcomes as suggested here has since been a central tenet of ARDS- and ALI-based research.

Strengths

1. The integration of historical, clinical, pathological, and experimental data.
2. Unpredictable variability in onset, severity, and outcome was noted.
3. Radiological progression was correlated with clinical state.
4. No bias was placed on any single therapeutic intervention.

Weaknesses

1. There was a small, selected sample.
2. Patients had different inspired oxygen concentration and ventilatory strategies (some were not ventilated).
3. Anecdotally, the paper was rejected initially because one of the reviewers believed that the syndrome described was actually a manifestation of ventilator-induced lung injury.

Relevance

A subsequent paper by Petty and Ashbaugh clarified their definition of 'adult respiratory distress syndrome', and other definitions have emerged since. However the 'adult' description ignores the fact that ARDS affects children, and the youngest patient in the authors' original series was 11 years old. Nevertheless, with considerable foresight, the authors suggested that intravenous fluids, drugs, oxygen, and ventilator settings might modify the course of the syndrome they defined. Digitalis, antibiotics, tolazoline, and steroids did not, in their opinion, alter outcome, and only end-expiratory pressure proved helpful in improving oxygenation. From this publication originated the now extensive list of pulmonary and non-pulmonary insults that can trigger ALI and ARDS, and it was postulated that 'physical and biochemical' influences beyond direct pulmonary damage were at work in an era before the explosion in modern immunology. Pathophysiological mechanisms thought to be involved included infection with associated local inflammation, shock and reperfusion, alveolar collapse and loss of compliance, oxygen toxicity, and surfactant dysfunction. All these hypotheses have expanded subsequently. Although the paper was based on a small selected group (12 patients of 272 with acute respiratory failure, 7 with trauma, 4 with pneumonia, and 1 with pancreatitis), the conclusions were intuitive and stimulated most, if not all, of ALI-/ARDS-based research until 1994.

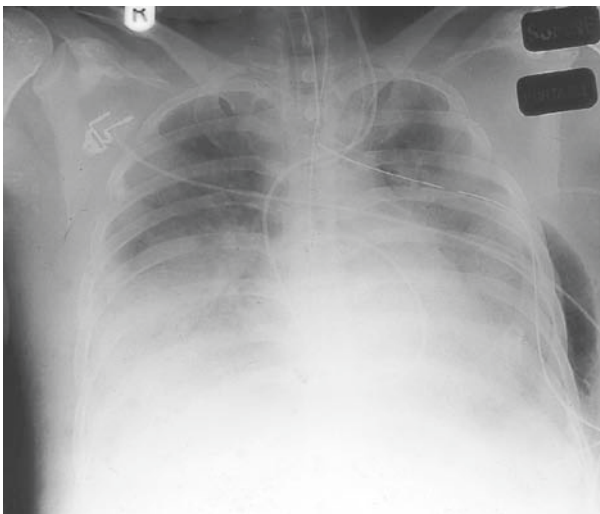

Fig. 2-8. *Chest radiograph of patient with ARDS*

The Heart

David Treacher FRCP

Introduction

To choose from the literature only ten papers on the heart and circulation that have been important to the development of contemporary intensive care is a daunting task. Inevitably, to many readers the choice will appear partial and unbalanced. The contributions have been selected on the basis of their importance to clinical practice in two areas relevant to intensive care: first, the function of the heart in generating the cardiac output and maintaining oxygen delivery to the tissues, and second, the influence of respiratory factors on the circulation, which is particularly relevant to the management of the mechanically-ventilated patient. Consequently, this selection may puzzle cardiologists, as there is no reference to coronary arteries, revascularization procedures, or ischemic pre-conditioning. Since the focus is the heart and the central circulation, recent advances in our understanding of vascular biology, the endothelium, and the role of mediators such as nitric oxide, prostaglandins, and cytokines in determining normal and pathological vascular responses, are also excluded.

It seemed inescapable that the starting point should be William Harvey's classic 72-page book, which shaped modern-day physiology, laid the framework for the understanding of circulatory function, and anticipated advances only recently made. Harvey synthesized his training under Fabricius and his own extensive observations in comparative anatomy to demonstrate with irrefutable logic that the blood must circulate around the body. This overturned Galen's view of the circulation that had dominated thinking and frustrated progress for over 1500 years. His clinical observations on the circulation in patients suggested that he understood the concept of both hypovolemic and hyperdynamic septic shock. He had to postulate the links between arteries and veins, as he had no means of visualizing capillaries: this had to await Malpighi's study of frog lungs, and the invention of the microscope by van Leeuwenhoek later in the seventeenth century. Apart from these advances, and Stephen Hales' remarkable experiments early in the following century, in which he measured the blood pressure and estimated cardiac output in horses, there was relatively little development of Harvey's revolutionary discovery for several hundred years.

The next major advance was provided by Adolf Fick at the end of the nineteenth century. Although he made major contributions to the understanding of the physiology of muscle contraction, and had predicted the Frank Starling Law of the Heart, he is best remembered for the enunciation of the principle of indicator dilution for the calculation of cardiac output. As a mathematician, Fick considered this relationship obvious, but it was to form the foundation of most of the methods subsequently used for measuring global and regional blood flow, and established the physiological link between the cardiac output and respiratory gas transport. It was, therefore, also the first statement of the relationship between oxygen delivery and consumption, but whether Fick, with his understanding of cardiac work, metabolic rate, and heat economy of the body, would have been an ardent advocate of the more extreme aspects of goal-directed therapy, is less certain.

Fick himself never applied the principle to measure cardiac output, and it was nearly 30 years later that its use in horses was first reported by Zuntz and Hagemann. Krogh and Lindhard employed another ingenious application of the indicator dilution technique to determine cardiac output by measurement of the absorption of an inhaled foreign gas of known solubility, in their case, nitrous oxide. Twenty years later, using acetylene as the indicator gas, Grollman published data on the cardiac output in health and disease, but the technique was laborious and potentially explosive! Stewart, in 1897, followed by Henriques, had first used direct intravenous injection of saline as an indicator, but it was Hamilton who subsequently

extensively applied and validated the dye dilution technique, developing it into a practical and robust method for use in human subjects.

Following a remarkable report from Forsmann, who had catheterized himself as he sought to develop techniques for introducing drugs directly into the heart, Cournand pioneered right heart catheterization in man, making it possible to measure right ventricular and pulmonary artery (PA) pressures, and collect mixed venous blood samples from the PA for determination of cardiac output by the Fick method. It was Bradley and Ganz who developed the PA balloon flotation catheter for studying the circulation in the critically ill, work observed by Swan, and subsequently successfully promoted by him in America.

Meanwhile, the investigation into skeletal and cardiac muscle function and the control of stroke volume started by Fick and developed by Frank, led to Starling's classic experiments on the canine heart-lung preparation, and culminated in his statement of the Law of the Heart in 1918. The subsequent debate about whether this relationship applied in the intact circulation was finally resolved by Sarnoff and Berglund's elegant studies, which also demonstrated that various factors could influence the stroke work–filling pressure relationship, and that there were, in fact, a family of such curves. The relevance of this work to the circulatory disturbances seen in critical illness was then extensively explored by Bradley, heralding the birth of circulatory critical care.

The interaction between cardiac and respiratory function, so relevant to management in intensive care, had first been studied in the ventilated patient by Cournand. Using the Valsalva maneuver, Schafer explored the relationship between intravascular and intrathoracic pressures in normal subjects and patients with heart failure. Aubier's studies illustrated the importance of the concept of respiratory work in patients with cardiac failure, and its relevance to the need for mechanical ventilatory support, and the process of weaning.



With the availability of appropriate technology and the improved understanding of cardiorespiratory physiology, dramatic advances were possible in the therapeutic manipulation of the circulation in the critically ill patient. These are exemplified by Mueller's remarkable studies, which emphasized the importance of considering the internal economy of the heart, and by Shoemaker's work on perioperative patients that spawned 'goal-directed' therapy. Despite inappropriate implementation of these results in ICUs to non-perioperative patients, its importance both prophylactically and in the early stages of critical illness is now established, and serves to remind the critical care physician that the primary purpose of the circulation is the provision of adequate 'ncrement to the tissues', as originally realized by Harvey nearly 400 years ago.

Fig. 3-1. *Stephen Hales measuring the blood pressure of a horse*

Title

*Exercitatio anatomica de motu cordis et sanguinis in animalibus
(on the movement of the heart and blood in animals)*

Author

Harvey W

Reference

Francofurti edition, published 1628, 72 pp.

Abstract

None

Summary

In the early chapters, Harvey describes the motion of the heart during contraction and relaxation, realizing that there is no direct interventricular passage as Galen had believed, and that a new path connecting the right and left sides of the heart had to be found. He speculated: 'Why not conclude that the blood does pass through porosities in the spongy lung tissue?'. He observed that the muscle mass of the heart was related to the metabolic needs in different animal species, and his description suggested that he realized that the heart had to generate the work to sustain the blood flow necessary to meet the metabolic needs of all the tissues. More remarkably, he seemed to understand the concept of atrial transport, and anticipate Starling's law of the heart:

'wheresoever there is a ventricle there is an ear required ... the ears not only (as is commonly believed) serve as the receptacle of blood (for what needs there any pulsation for the retaining of it?) but the ears do beat and contract themselves and the first movement of the blood are the ears which cast the blood into the ventricles and through their action (the blood) is thrust out further and more swiftly ... as when you play at ball you can strike farther and more strongly taking it on the rebound than you could only by throwing it out of your hand.'

The middle chapters describe the experiments that drove him to dismiss Galen's theories about the circulation as 'obscure, inconsistent and impossible to the thoughtful student'. The key observations: (i) tight ligatures around the limbs prevent blood flow, to the extremities, (ii) the valves in the veins and the heart allow only unidirectional blood flow, and preclude significant oscillatory movement, (iii) blood volume is estimated to be one-tenth of body weight from exsanguination experiments in sheep and other animals, (iv) the filled human ventricle contains up to 3 ounces of blood – if only 1 ounce was ejected in systole (he clearly understood the concept of ejection fraction), up to 80 pounds of blood would be ejected in under half an hour, (v) by milking the arm veins rapidly 'more blood passes under one's finger, in not too many minutes, than there is in the whole body'.

He concluded that, as the amount of blood both flowing from the heart into the arteries and returning to the heart in the veins over only half an hour was vastly more than the whole body could either contain or create from the food or drink consumed, the only logical interpretation was that *'the same blood must be circulating around the body'*.

The final chapters emphasize the importance of perfusion pressure for appropriate regional distribution of cardiac output, and describe the circulatory changes associated both with sepsis and low cardiac output:

'... in boys with an undoubted fever the pulses are always swift and by gripping of their fingers, I could easily perceive from the pulse when the fever was in its strength ... and at times there may even be a pulse in the gums and teeth. On the other side when the heart beats faintly as in fainting, hysterical symptoms, defect of pulse, weak people and those that are departing, the pulse can be detected neither in the wrist nor the temples.'

Citation count 160

Related references

1. Galen (130 AD) *On the Natural Faculties* [English translation]. London: AJ Brock, 1916.

Key message

Blood does not flow and ebb in the arteries, but circulates around the body.

Why it's important

Simple observations that required no sophisticated technology refuted the Galenic dogma that had held sway for over 1500 years. This revolutionized the understanding of the human body, enabled the strategic function of the circulation to be appreciated, and established the central principles of modern physiology and medicine.

Strengths

A beautiful presentation of anatomical observations and simple experiments made in man and other animals that demonstrated, with the use of quantitative reasoning, that Galen's view of the circulation was logically untenable. It established the modern scientific method: an observation generates an hypothesis, tested by experiment, and leading to logical conclusions.

Weaknesses

Few original data are presented, but the available technology was very limited. However, criticism of the masterpiece that produced the major revolution in biology, and which underpins modern circulatory physiology, seems foolhardy and impertinent.

Relevance

The widespread practice of blood letting diminished, and blood transfusions were attempted, but mostly failed as a result of transfusion reactions and infection. Harvey stated that drugs injected intravenously would produce more rapid and reliable effects, but it was 200 years before doctors adopted this practice.

Most importantly, this work was the foundation of circulatory physiology and the modern scientific method. Hamilton's judgement over 300 years later was: 'This great work stands by itself – in the medical sciences there is nothing else in the same class'.



Fig. 3-2. Painting by Robert Hannah of Harvey demonstrating his experiments on deer to King Charles 1 and the boy prince (Original: Royal College of Physicians, London)

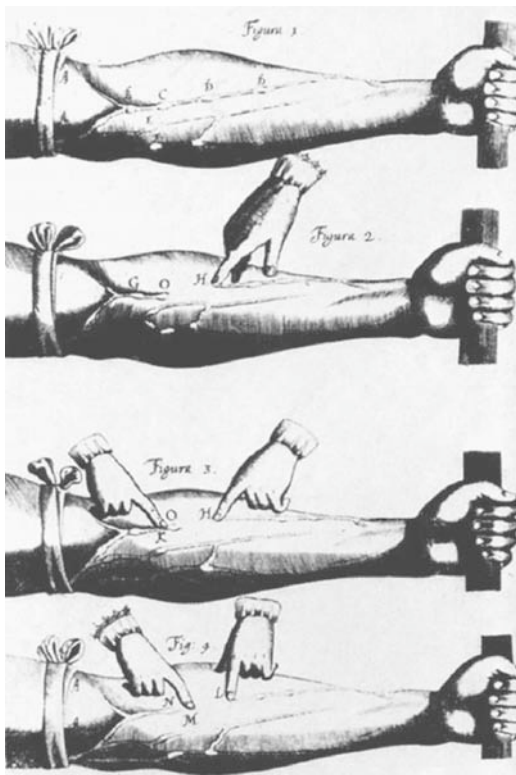

Fig. 3-3. Woodcuts used by Harvey to demonstrate the unidirectional flow of blood in veins due to the presence of valves, and how he estimated the flow of blood through the forearm veins (Original: World Health Organization, Geneva.)

Title

Über die Messung des Blutquantums in den Hertzventrikeln

Author

Fick A

Reference

Würzburg Physikalische Medizinische Gesellschaft July 1870

Abstract

Not applicable

Summary

This was a brief communication to the Würzburg Medical Society, where its importance as a method for determining cardiac output, and hence stroke volume, was immediately realized. Fick enunciated the general principle of indicator dilution, that the flow of a fluid may be calculated from knowledge of the amount of a substance added to or removed from the fluid stream, and the concentration difference resulting from such addition or removal. He illustrated the principle with reference to oxygen consumption (VO_2) and carbon dioxide production (VCO_2) and the resulting arteriovenous content difference of these gases. The accompanying diagram and mathematical statement illustrate that if the amount of oxygen absorbed by the lungs spacing and the oxygen concentrations in both arterial and mixed venous blood are known, the blood flow or cardiac output to achieve this consumption can be calculated. He pointed out that using the corresponding carbon dioxide data provided a control for the other calculation. Using canine data on the oxygen content of arterial and venous blood, and from earlier calculations of the amount of oxygen absorbed by a man in 24 hours, he calculated a cardiac output of 5.4 L/min. He even *assumed* a heart rate of 70 beats/min to calculate a stroke volume of 77ml!

Citation count 80

Related references

1. Zuntz N, Hagemann O. Untersuchungen über den Stoffwechsel des Pferdes bei Ruhe und Arbeit. *Landw Jb* 1898; 27.
2. Krogh A, Lindhard J. Measurements of the blood flow through the lungs of man. *Scand Arch Physiol* 1912; **27**: 100.

Key message

Cardiac output, and hence stroke volume, can be calculated from measurement of oxygen consumption and the arteriovenous oxygen concentration difference.

Why it's important

The inability to measure cardiac output in the intact circulation had prevented progress in cardiac and circulatory physiology over the previous 250 years. This communication not only provided a method immediately applicable to animal studies, but also established the principle on which the dye and thermal dilution techniques, the inert gas methods for determining pulmonary blood flow, and the clearance methods for measuring renal and hepatic flow are based.

Strengths

A simple and clear statement of a truth that is self-evident once understood.

Weaknesses

Fick presented no data of his own, since he apparently did not have the necessary equipment, and considered the principle self-evident and logically sound! On this basis, the credit might be given to the Romans, who applied the same principle, using Tyrian purple as the indicator, to calculate the flow through their main drainage system.

Relevance

Although the example given related to oxygen transport, the principle had far wider implications, and heralded a period of rapid advance in the quantitative assessment of the circulation and understanding of cardiac function. With this publication, Fick made a lasting impact on the measurement of cardiac output and the further development of circulatory physiology.

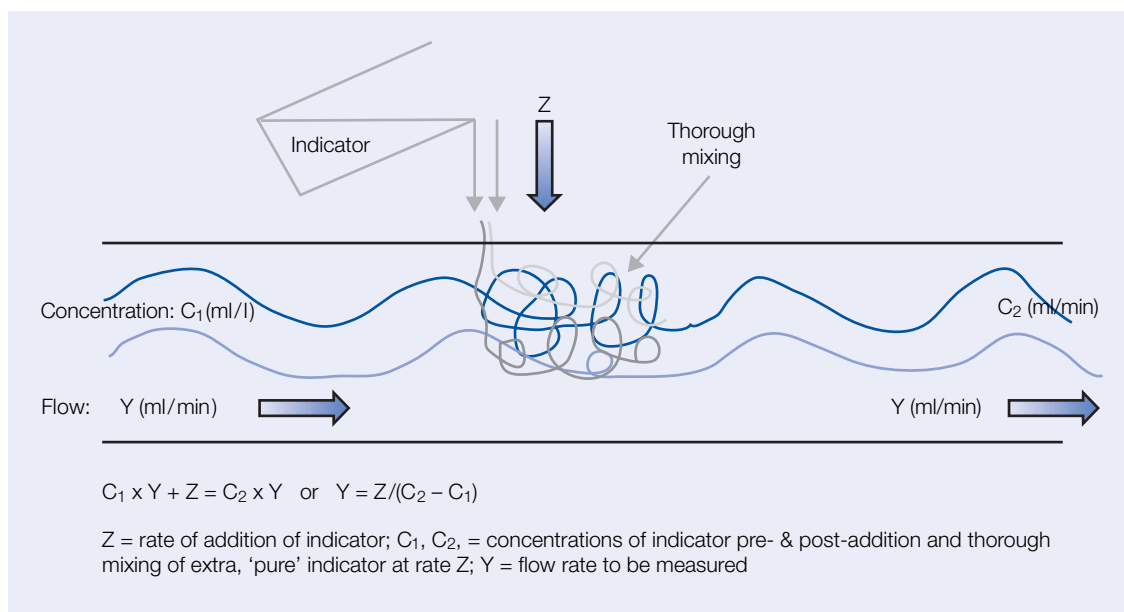

Fig. 3-4. Fick's principle of indicator dilution for measurement of flow

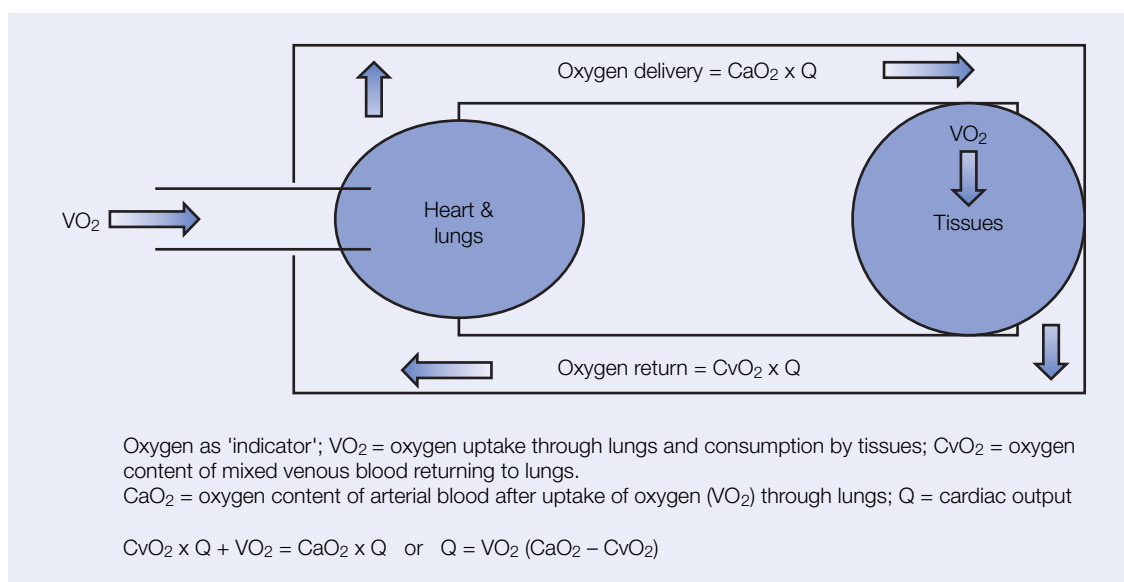

Fig. 3-5. Fick method for determination of cardiac output in man

Title

Simultaneous determination of the greater and lesser circulation time, of the mean velocity of blood flow through the heart and lungs, of the cardiac output and an approximation of the amount of blood actively circulating in the heart and lungs

Author

Hamilton WF, Moore JW, Kinsman JM, Spurling RG

Reference

Am J Physiol 1928; **85**: 377

Abstract

108

Summary

This brief communication extended the principle of indicator dilution to the use of a detectable dye to calculate both cardiac output and effective intrathoracic blood volume. After a bolus intravenous injection of iodinated phenolphthalein, the changing concentration of this dye is measured in samples of arterial blood collected every 1–2 seconds. From these data, a dye concentration curve is plotted, which shows a brief delay after injection as the dye passes through the pulmonary circulation, followed by a rapid rise to a peak value at about 8 seconds, and then an exponential decline until recirculation of the dye causes a further rise (Fig. 3-6).

The mono-exponential form of the initial decline is described mathematically and projected to zero concentration from the point of recirculation (dotted portion of curve). The cardiac output is inversely proportional to the area under this 'dye concentration-time' curve, and the intrathoracic blood volume is the product of the mean circulation time and cardiac output.

There was a close correlation between these calculations when performed in various 'in vitro' models and 'in vivo' animal experiments. Attention is drawn to the importance of the relationship between intrathoracic lung volume and 'factors which govern the filling of the left ventricle'.

Citation count

11

Related references

1. Stewart GN. Researches on the circulation time and on the influences which affect it. IV. The output of the heart. *J Physiol* 1897; **22**: 159.
2. Hamilton WF, Moore JW, Kinsman JM, Spurling RG. Studies on the circulation. IV. Further analysis of the injection method, and of changes in hemodynamics under physiological and pathological conditions. *Am J Physiol* 1932; **99**: 534–551.
3. Hamilton WF, Riley RL, Attyah AM *et al.* Comparison of Fick and dye injection methods of measuring cardiac output in man. *Am J Physiol* 1948; **153**: 309–321.

Key message

This technique allows both cardiac output and intrathoracic blood volume to be calculated from analysis of the classic dye dilution curve, obtained from measurement of the arterial concentration of dye in successive samples after a bolus intravenous injection.

Why it's important

This publication led to considerable research activity and publications over the following decade that established the dye dilution technique as a reliable method for determining cardiac output and intrathoracic blood volume, without the need to obtain values for mixed venous oxygen content either directly from the pulmonary artery, or from estimates that hitherto had involved considerable error. This resurgence of interest in indicator dilution encouraged the development not only of new photoelectric technology that allowed dye samples to be read optically, making this technique far less laborious, but also of techniques using radiation and temperature as indicators.

Strengths

A succinct statement presenting original work which described a new indicator dilution technique based on the ideas and early work of Fick and Stewart. The principles underlying the quantitative analysis of the classic dye dilution curve are clearly presented, and the importance of the ability to measure intrathoracic blood volume is emphasized.

Weaknesses

Although essentially only an abstract, few methodological details and no data are provided. This is ironic, considering that the work described permitted major advances to be made in the quantitative analysis of cardiac function.

Relevance

This application of Fick's indicator dilution principle provided a practical method for measuring cardiac output and intrathoracic blood volume in man, and resulted in major advances in human circulatory physiology. It also led directly to the development of the indocyanine green and thermodilution techniques, which became the main methods for measuring cardiac output in cardiology laboratories and intensive care units.

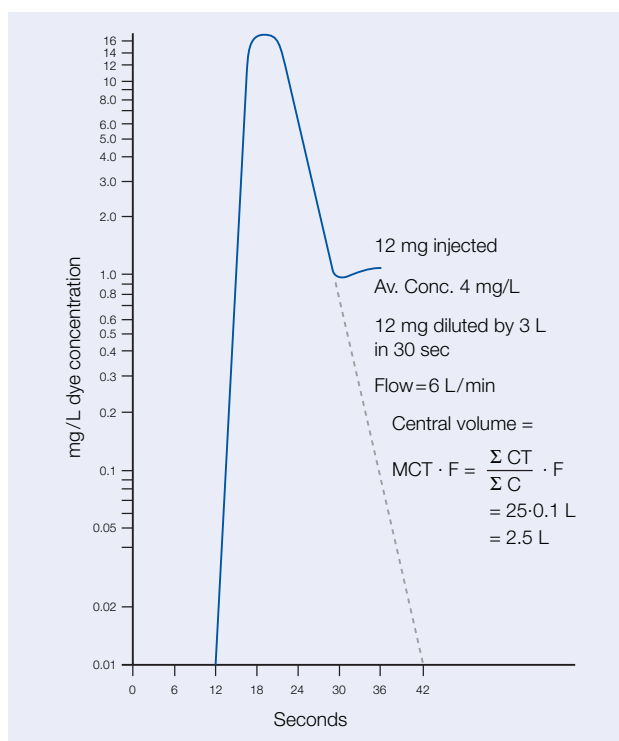

Fig. 3-6. Example of the dilution curve obtained by Hamilton following injection of phenol-tetraiodo-phthalein sodium into a vein and taking arterial samples. From this data, the cardiac output, the total and mean circulation time, and the intrathoracic blood volume can be calculated

Title

Physiological studies of the effects of intermittent positive pressure breathing on cardiac output in man

Author

Cournand A, Motley HL, Werko L, Richards DW

Reference

Am J Physiol 1948; **152**: 162–174

Abstract

None

Summary

This paper investigated the cardiorespiratory effects of three different patterns of intermittent positive pressure ventilation. Thirty-three experiments were performed in 29 normal human subjects. All subjects underwent right heart catheterization as previously described by Cournand, intravascular and intrapleural pressures were recorded, and cardiac output was measured by the direct Fick method.

Three patterns of ventilation were used, and are illustrated in Fig. 3-7. Type I: gradual increase and decrease in pressure during both inspiration and expiration, and an inspiratory to expiratory time ratio (I:E ratio) of unity, but with positive end-expiratory pressure throughout the cycle. Type II: a rapid increase and decrease in pressure, an increased I:E ratio, and a positive end-expiratory pressure. Type III: a gradual inspiratory pressure ramp, rapid expiratory drop in pressure, an I:E ratio, of unity, and no PEEP.

The studies showed that the cardiac output fell in proportion to the increase in mean airway pressure in Types I and II, but there was no change in cardiac output with Type III. The right ventricular transmural filling pressure (intravascular minus pleural pressure) decreased during the inspiratory cycle and increased during the expiratory phase with all three types of respiratory curve. The change in cardiac output was related to the change in mean transmural filling pressures. The conclusion was that during inspiration, there is a fall in cardiac output that is compensated for during expiration. If the pressure drop in expiration is rapid, resulting in a low intrapleural pressure and high transmural pressure, the circulatory compensation will be complete, provided expiration is of sufficient duration. From a circulatory perspective, the airway pressure profile during intermittent positive pressure breathing should be a gradual increase during inspiration, a rapid drop during expiration, and an I:E ratio <1 without positive end-expiratory pressure.

Citation count

630

Related references

1. Cournand A, Ranges HA. Catheterisation of the right auricle in man. *Proc Soc Exp Biol Med* 1941; **46**: 462–466.

Key message

The pattern of ventilation employed during positive pressure ventilation determines the circulatory effects. These effects can be explained by the changes in the right ventricular transmural pressure.

Why it's important

This study illustrates the important interaction between the respiratory system and the circulation during mechanical ventilation. The experiments used the latest advances in technology and monitoring to demonstrate important physiological principles, notably that transmural pressures represent the true distending pressures, and should be used when assessing cardiac function. This is still frequently overlooked in ICU practice!

Strengths

A classic paper in which a hypothesis was stated, tested using clearly described methods, and logical conclusions were then drawn from the results. The importance of achieving 'steady state' conditions was emphasized.

Weaknesses

Little information about the subjects was provided, and no mention is made of the ethical considerations of performing right heart catheterization in 29 normal subjects.

Relevance

Demonstrated some of the important physiological aspects of cardiopulmonary interaction, and came up with a practical approach to positive pressure ventilation that would minimize circulatory disturbance.

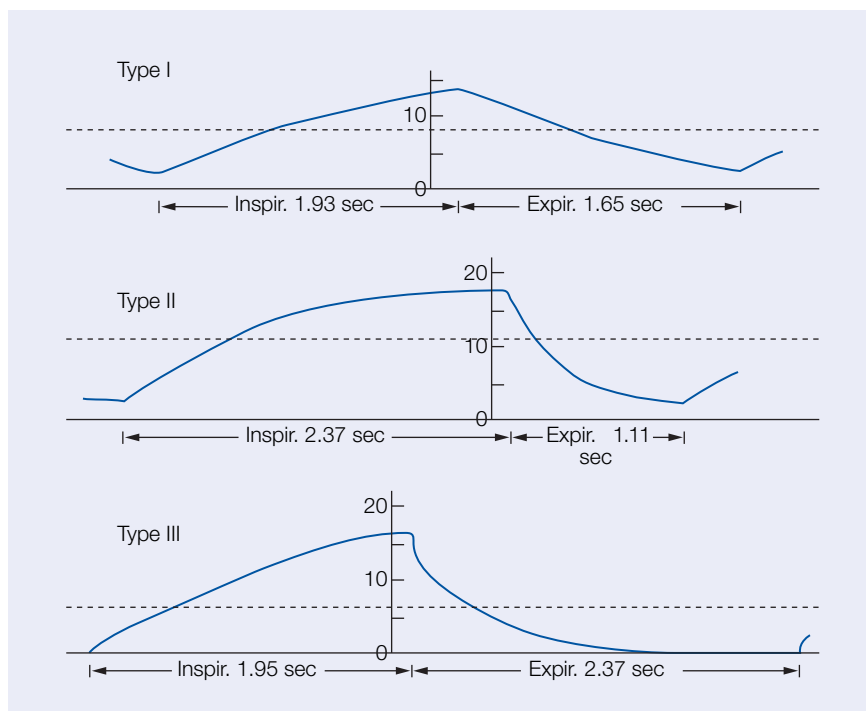

Fig. 3-7. The three patterns of positive pressure curve used during mask ventilation. The dotted line represents the mean mask pressure for the entire respiratory cycle

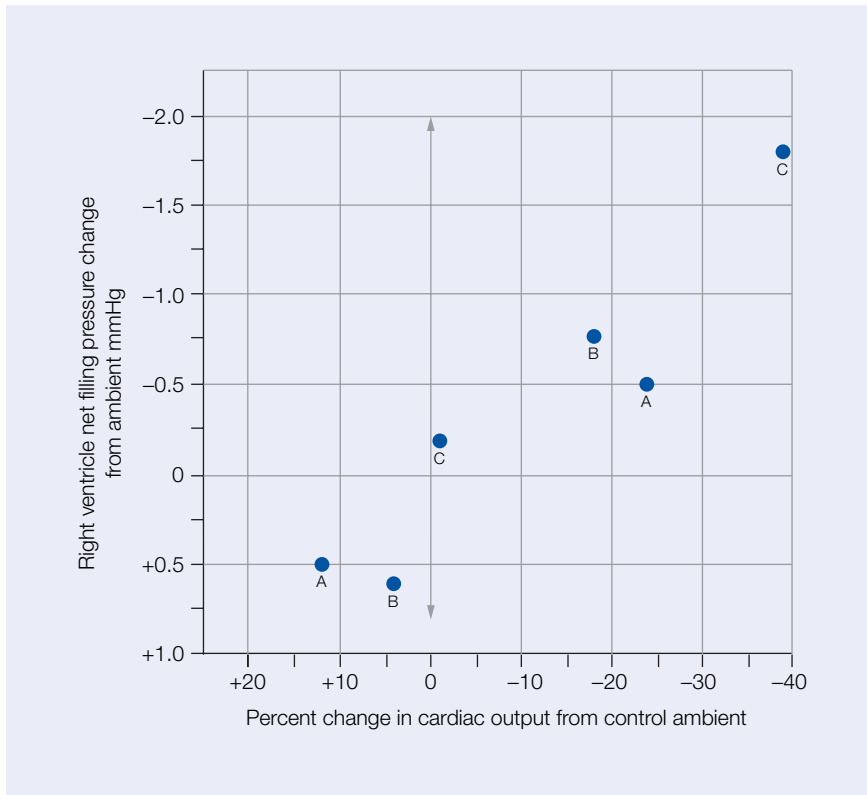

Fig. 3-8. Relationship between mean net right ventricular filling pressure and changes produced in cardiac output. Each of three cases (A,B,C) are studied with the types of intermittent positive pressure ventilation

Title

Ventricular function: Starling's law of the heart studied by means of simultaneous right and left ventricular function curves in dog

Author

Sarnoff SJ, Bergland E

Reference

Circulation 1954; **9**: 706–708

Abstract

None

Summary

Starling stated in his Linacre lecture on 'Law of the Heart' that 'the energy of ventricular contraction, however measured, is a function of the length of the muscle fibres prior to contraction'. Over the following 40 years, a number of studies questioned the validity of this statement, and particularly whether it was relevant to the intact circulation. Sarnoff and Bergland argued that these studies were variously flawed, since (a) cardiac output, stroke volume, or ventricular work per minute, and not stroke work, were used as measures of 'the energy of contraction', (b) some compared right atrial pressure and left ventricular work, (c) a single 'Starling' curve could not be expected to explain all observed phenomena, and there were in fact a series or 'family' of curves for each ventricle – a different relationship or curve would apply if all factors that could influence myocardial contractility were not held constant.

This paper investigated the applicability of Starling's Law of the heart in the intact canine circulation. An anesthetized, open chest dog model (which avoids the confounding effects of changes in intrapleural pressure) is described, in which atrial filling pressures were manipulated by infusing or removing blood from the circulation by raising or lowering a reservoir that was connected by a cannula to the right atrium. Cardiac output, heart rate, atrial filling pressures, and systemic and pulmonary artery pressures were continuously recorded as circulatory manipulations were performed.

Over 300 sets of data were obtained under controlled conditions, and ventricular stroke work was calculated and plotted against the corresponding atrial filling pressure. The resulting ventricular function curves demonstrated a consistent relationship between these two variables, provided that factors that could alter myocardial contractility were held constant. The effects of severe anemia, coronary artery occlusion, and epinephrine were studied, and confirmed their hypothesis that a family of curves existed for each ventricle, with a different relationship applying when ventricular contractility was changed.

Citation count

618

Related references

1. Starling EH. The Linacre Lecture on the law of the heart given at Cambridge 1915. London: Longmans, Green & Co, 1918.
2. Frank O. Zur Dynamik Des Herzmuskels. *Ztschr Biol* 1895; **32**: 370.
3. Patterson SW, Starling EH. The mechanical factors which determine the output of the ventricles. *J Physiol* 1914; **48**: 357.

Key message

The Frank–Starling relationship applies to the intact circulation, and there is no evidence of a ‘descending limb’ at high atrial pressures, provided that (i) the effective right and left atrial pressures are related to the stroke work generated by the corresponding ventricle, and (ii) factors influencing myocardial contractility are held constant. Factors that influence myocardial contractility alter the relationship between filling pressure and stroke work to produce a ‘family’ of curves for each ventricle.

Why it’s important

It established the validity of Starling’s Law as the basis for analyzing the performance of the heart in health and disease. It explained the reasons why earlier observations could not be interpreted on the basis of a simple single curve analysis of each ventricle, and demonstrated that once this was taken into account, the stroke work reached a plateau but did not fall at high filling pressures. It also emphasized some important points that are still frequently overlooked. (i) It is important to consider the *effective* distending pressure, and that if the pericardial/pleural pressures are high, then the true distending pressure of the ventricle will be considerably less than that directly measured from an intracardiac catheter. (ii) The author accepted that if there were changes in the elasticity or tone of the ventricle, then volume rather than pressure preload would better reflect the effective stretch applied to the myocardial fibers. However, the technology was only available at the time to measure pressure change within the ventricles. (iii) The steep initial part of the filling pressure/work relationship results in very small rises in atrial pressure, producing marked increases in ventricular work. Therefore, very precise measurements of change in effective filling pressure are required, particularly in the normal heart. In clinical practice today, there is often a failure to appreciate that an increase of only 1 cm water in the right atrial pressure may produce large changes in the stroke work generated by both ventricles.

Strengths

An animal model for assessing cardiac function is described and thoroughly evaluated. A huge amount of data is summarized and clearly presented: it would nowadays be translated into multiple publications from multiple authors and produce several higher degrees! Potentially confounding circulatory factors are kept constant as the effects of the imposed circulatory changes are assessed.

Weaknesses

Few of the original data are presented: the results are a summary of a vast body of work with only representative data presented. The potential importance of metabolic factors was discussed, but it is not clear that these were adequately controlled. This paper would almost certainly not have been accepted today in its current form, but it nonetheless represents a phenomenal body of work that has made a great contribution to cardiac physiology.

Relevance

It applies Starling’s Law of the Heart to the intact circulation, and forms the basis of a logical approach to analyzing the circulation in the critically ill patient. By analyzing the performance of each ventricle from a knowledge of the six key variables (both atrial pressures, pulmonary artery and systemic pressures, cardiac output, and heart rate), the circulatory abnormality can be quantified. From this information, it can be logically decided whether volume loading, vasodilator, or inotropic therapy is the appropriate treatment.

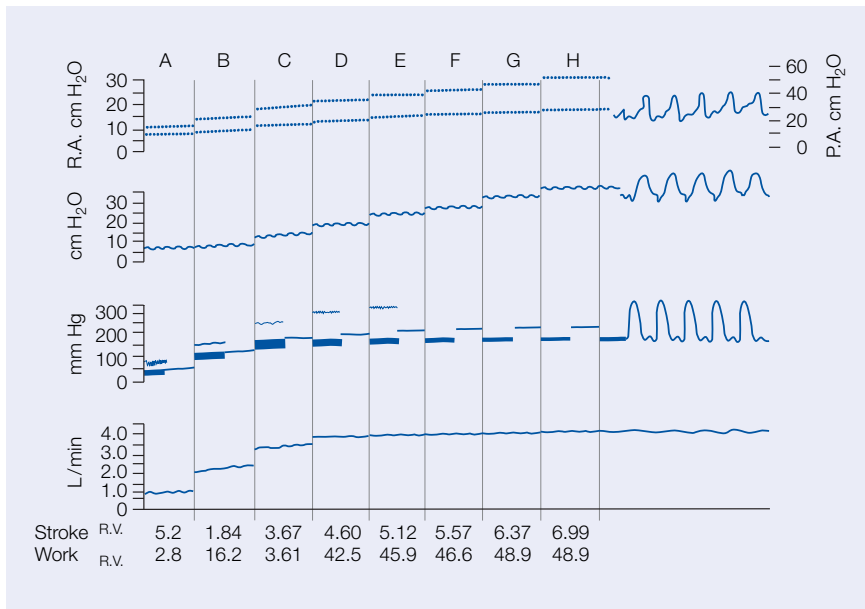

Fig. 3-9. Tracing of pressures recorded during a typical experiment showing increases in right and left atrial filling pressures, aortic pressure, and cardiac output as the reservoir is progressively elevated at half-minute intervals

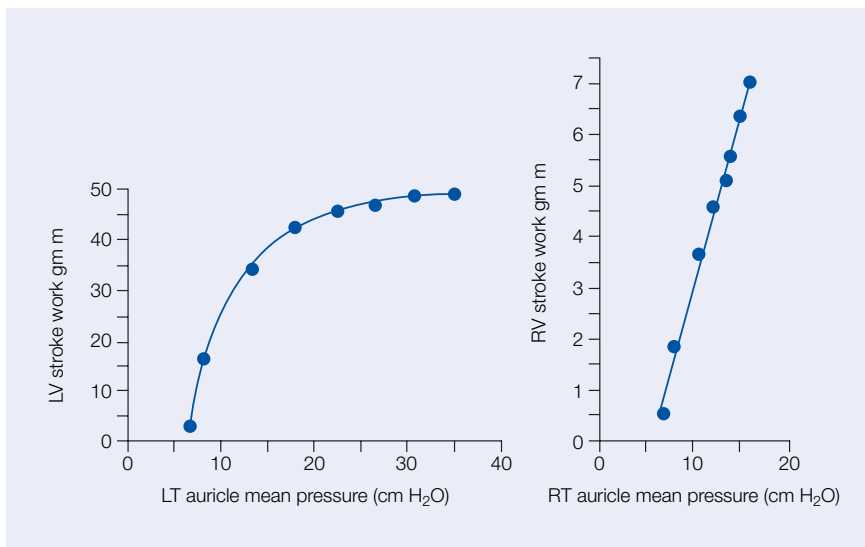

Fig. 3-10. Left and right ventricular function curves plotted from data above (Fig 3-9). No evidence of a descending line

Title

Effects of Valsalva's manoeuvre on the normal and failing circulation

Author

Sharpey-Schafer EP

Reference

BMJ 1955; **I**: 693–695

Abstract

None

Summary

The maneuver first described by Valsalva in 1707 was originally used to increase pressure in the Eustachian tube and air-filled cavities of the ears, but it was Sharpey-Schafer who investigated the circulatory effects of this respiratory maneuver. This paper reports the changes in diastolic and pulse pressure produced by blowing a mercury column to 40 mmHg and holding it at that level for 10 seconds in 62 normal subjects and 63 patients with heart failure of varying etiology. *All the patients were in sinus rhythm with a jugular venous pressure raised between +2 and +25 cm above the sternal angle.* Continuous arterial and intrathoracic pressures were measured throughout the maneuver, which was conducted with the subjects lying in the semi-supine position.

There was a striking difference in the responses of the two groups (Fig. 3-11). Normal subjects showed the classic four phase arterial pressure response, with a transient rise followed by a marked fall in diastolic and pulse pressure over 6–7 seconds, and a small recovery in pressures before the end of the maneuver. A further brief fall, paralleling the drop in intrathoracic pressure, occurs when the maneuver ends, after which there is a surge in pressure, and a reflex bradycardia as the venous return is restored. In marked contrast, a 'square wave' response was observed in patients with clinical heart failure.

Citation count 226

Related references

1. McIntyre KM, Vita JA, Lambrew CT, Freeman J, Loscalzo J. A non-invasive method of predicting pulmonary capillary wedge pressure. *N Engl J Med* 1992; **327**: 1715–1720.

Key message

The Valsalva maneuver is a simple and repeatable method for distinguishing the normal from the failing circulation. It can be used clinically by feeling the pulse.

Why it's important

It is an elegant demonstration of the physiology of the effect of changes in intrapleural pressure on the circulation. Although Schafer believed it was a defining test for heart failure, it in fact reflects intrathoracic blood volume, which is raised in many, but not all, forms of heart failure. Furthermore, a 'square wave' response can be produced

if a normal subject is placed upside down on a tip table. It can therefore be used to identify non-invasively whether a patient is appropriately volume resuscitated: if there is an exaggerated normal response, a fluid challenge is appropriate, but a 'square wave' response indicates adequate left ventricular volume preload. McIntyre subsequently demonstrated that the response could be quantified and shown to reflect left atrial pressure.

Strengths

Elegant and humorous presentation of a large body of work that was synthesized to produce an important clinical message, accompanied by a lucid analysis of the physiology of raising intrathoracic pressure.

Weaknesses

The original data are not presented, and there is only a scanty description of the heterogeneous group of patients with heart failure. The conclusion that the test defined heart failure was incorrect.

Relevance

Although performed on spontaneously breathing subjects, this maneuver is relevant to the mechanically-ventilated patient. Schafer realized that in the anesthetized, intubated patient, a small imposed increase in intrathoracic pressure produces much greater changes than in the spontaneously breathing normal subject. The response obtained reflects the level of imposed pressure, the degree of peripheral vasodilatation, and the intrathoracic blood volume. It explains the fluctuation in arterial pressure with ventilation seen in the patient who is inadequately volume resuscitated, and can be used at the bedside to assess left ventricular volume preload.

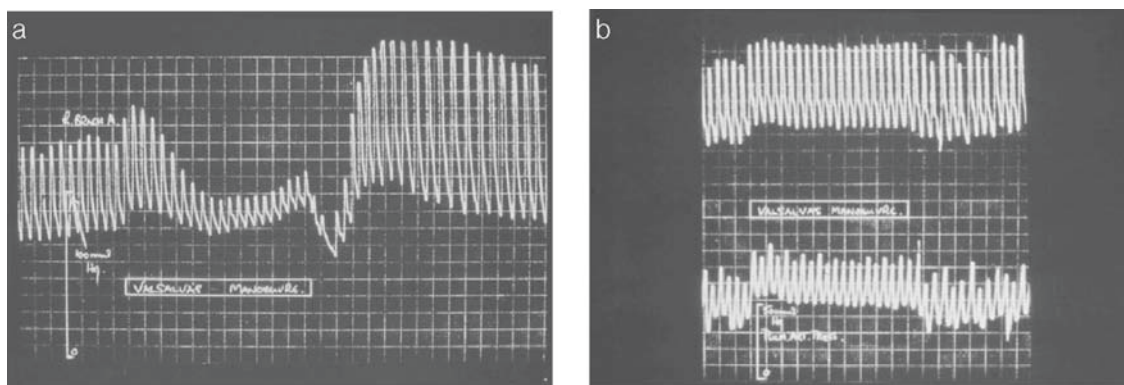

Fig. 3-11. (a) normal Valsalva response. (b) square wave response observed in patients with clinical heart disease

Title

The influence of atrial pressure on cardiac performance following myocardial infarction complicated by shock

Author

Bradley RD, Jenkins BS, Branthwaite MA

Reference

Circulation 1970; **42**: 827–837

Abstract

Not available

Summary

Six patients with cardiogenic shock and pulmonary edema were studied between 36 hours and 10 days after an acute myocardial infarction, which was diagnosed on the basis of ECG and enzyme studies. Four patients were investigated during spontaneous breathing, and two during intermittent positive pressure ventilation. The patients were catheterized with internal jugular lines, arterial, and pulmonary artery lines, from which mean systemic arterial and pulmonary artery pressures, right and left atrial pressures (RAP, LAP), heart rate, and cardiac output by thermodilution were measured. The left atrial pressure was recorded directly, using a modified transeptal technique performed at the bedside without radiographic control. Stroke work index was derived and plotted against the respective mean atrial pressure to produce right and left ventricular function curves.

Serial measurements were made as atrial filling pressures were reduced by controlled, rapid venesection, increased by re-transfusion and inflation of thigh cuffs, and also during an isoprenaline infusion.

The importance of the relationship between RAP and LAP and the impact of fluid removal or infusion in relation to formation and clearance of pulmonary edema was demonstrated.

Citation count

19

Related references

1. Branthwaite MA, Bradley RD. Measurement of cardiac output by thermal dilution in man. *J Appl Physiol* 1968; **24**: 434–438.
2. Bradley RD. *Studies in Acute Heart Failure*. Edward Arnold. 1977.

Key message

Increasing RAP by volume loading in patients with impaired ventricular function following myocardial infarction cannot be assumed to produce a clinically useful increase in stroke volume and cardiac output, and risks raising LAP to a level that produces pulmonary edema. The changed relationship between RAP and LAP means that only a small increase in an apparently normal or only slightly raised RAP can raise LAP to a level at which pulmonary edema develops. Volume loading can only be performed safely in such patients if guided by measurements of LAP.

Why it's important

This work applies the principles of cardiac function first stated by Frank and Starling and studied in the intact canine circulation by Sarnoff to the management of patients with

circulatory shock. It demonstrates that analysis of the circulation in terms of the relationship between RAP and LAP and the stroke work performed by the ventricles allows appropriate decisions to be made about patient management, and the value of treatment with volume loading or inotropic therapy.

Strengths

A remarkable study which involved the application of new techniques and the collection of an enormous amount of data under controlled clinical conditions, and which established the value of quantitative assessment of the circulation in the management of critically ill patients.

Weaknesses

Ethical considerations would today preclude performing circulatory manipulations that were not always beneficial to the individual patient, although the authors do state that the studies were only undertaken when 'survival was improbable with conventional treatment'; informed consent was not possible in five of the patients due to impairment of conscious level. No mention is made of the potentially confounding effect of changing intrathoracic pressure influencing the transmural distending pressure, particularly in the two ventilated patients.

Relevance

At the time, many clinicians believed that volume loading was appropriate to increase cardiac output in patients with circulatory shock. This study demonstrated that this approach was frequently futile as the relationship between LAP and left ventricular stroke work was virtually flat in many of these patients, and therefore no increase in cardiac output would result despite achieving a marked rise in LAP. Furthermore, the rise in LAP risked deterioration in the patient's condition due to the formation of pulmonary edema with consequent hypoxemia, reduced pulmonary compliance, and increased work of breathing.

This study also demonstrated the value of both the use of the new invasive techniques for circulatory assessment, and the application of the advances in cardiac physiology in the management of the critically ill patient.

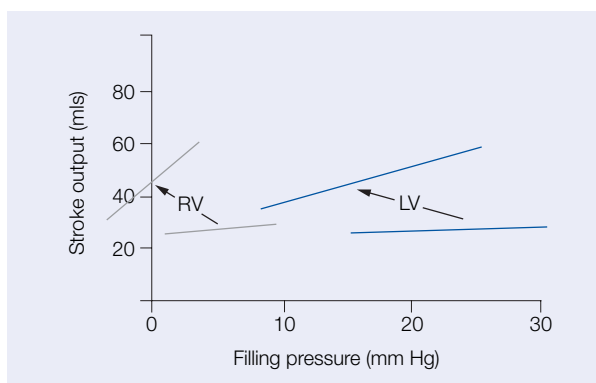

Fig. 3-12. Portable equipment used to study cardiac function, designed by Bradley and colleagues

Fig. 3-13. Left and right ventricular function curves after an anterior myocardial infarction and effects of a dilating inotrope

Title

Effect of isoproterenol, l-norepinephrine and intra-aortic counterpulsation on haemodynamics and myocardial metabolism in shock following acute myocardial infarction

Author

Mueller H, Ayers SM, Gianelli S, Conklin EF, Mesara JT, Grace WJ

Reference

Circulation 1972; **45**: 335–351

Abstract

Not available

Summary

The effects of isoprenaline, norepinephrine, and intra-aortic balloon counter-pulsation on hemodynamics and myocardial metabolism were studied in patients with severe cardiogenic shock following acute myocardial infarction. Before intervention, the cardiac index was markedly reduced, averaging only 1.35 L/min/m². Mean aortic pressures were <65 mmHg, and the reduced coronary blood flow and myocardial oxygen consumption were associated with high myocardial oxygen extraction (mean 78%) and with lactate production. Isoprenaline increased cardiac index heart rate and coronary blood flow despite a reduced diastolic aortic pressure, but increased myocardial lactate production. Noradrenaline increased mean aortic pressure, coronary blood flow, and the mean myocardial oxygen consumption, and although myocardial lactate production changed to extraction, the myocardial oxygen extraction remained abnormally high at >73%. Cardiac index did not change. In contrast, intra-aortic balloon counter-pulsation increased mean aortic pressure, cardiac index by an average of 0.5 L/min/m², and also coronary blood flow. Although myocardial oxygen extraction was unchanged, the myocardial lactate and oxygen extraction improved towards more normal values. Twenty one of the 23 patients in this study died.

Citation count

130

Related references

1. Corday E, Williams JH, DeVera LB, Gold H. Effect of systemic blood pressure and vasopressor drugs on coronary blood flow and the electrocardiogram. *Am J Cardiol* 1959; **3**: 626–637.
2. Mueller H, Ayres SM, Konklin EF *et al*. The effects of intra-aortic counter-pulsation on cardiac performance and metabolism in shock associated with acute myocardial infarction. *J Clin Invest* 1971; **50**: 1885.
3. Maroko PR, Kjekshus JK, Sobel BE *et al*. Factors influencing infarct size following experimental coronary artery occlusion. *Circulation* 1971; **43**: 67–82.

Key message

(i) The benefits of therapy in cardiogenic shock following myocardial infarction can only be properly assessed by considering the effects on myocardial oxygenation, and cannot be judged solely on improvements in overall hemodynamics.

(ii) Isoprenaline produces a relatively small increase in cardiac work at the cost of a significant increase in myocardial ischemia.

(iii) Norepinephrine increases myocardial oxygen consumption and produces a striking improvement in myocardial lactate metabolism, but myocardial oxygen extraction remained very high, indicating that cardiac oxygen delivery was still inadequate for the increased work resulting from the increased after-load.

(iv) Intra-aortic counter-pulsation provides the unique combination of improving coronary perfusion while decreasing cardiac work, leading to the indices of myocardial oxygenation becoming almost normal as well as improving peripheral perfusion. This results in a more efficient cardiac performance, since the same amount of cardiac work produces more external work, and myocardial ischemia is relieved.

Why it's important

This study addresses an interesting design feature of the circulation: the heart has to provide its own energy supply. Any pharmacological treatment used in cardiogenic shock should be based on a knowledge of the metabolic state of the myocardium and consider both the internal and external economy of the heart. The use of any pharmacological agent almost inevitably represents a compromise between increasing cardiac work to improve global oxygen delivery and exacerbating myocardial ischemia. Isoprenaline is not physiologically attractive in severe cardiogenic shock from myocardial infarction, and although noradrenaline has some benefits, there is no evidence that it relieves myocardial ischemia either. Intra-aortic balloon counter-pulsation represents the ideal therapy physiologically, since external work is provided to the circulation while cardiac work is reduced and myocardial perfusion is improved. This paper illustrates important principles about the relationship between the global and myocardial circulations. The evidence that has been present for some time that beta-blockers may have a role in this setting follows logically from this work.

Strengths

A remarkable study in which a protocol was followed in extremely ill patients who predictably had very high mortality. It provided important insights into myocardial metabolism in the severely damaged heart, and provides the basis for logical therapy.

Weaknesses

Only one patient was treated with both isoprenaline and norepinephrine and two received both norepinephrine and intra-aortic counter-pulsation, but all others received only one form of treatment. Ideally, all patients should have received all treatments serially so that they could have provided internal controls, since the baseline cardiac index and systemic vascular resistance varied considerably between the groups, although we are not told whether these differences were statistically significant.

Relevance

This study highlighted the need to consider the effects of therapy on myocardial metabolism rather than simply the effects on global hemodynamics and the amount of external work performed by the heart. Such considerations have relevance in considering other causes of circulatory failure, particularly sepsis, where the extent of the disruption to myocardial metabolism is often concealed by virtue of the characteristically vasodilated state that allows high cardiac index notwithstanding significant myocardial failure. Treatment of these patients with the vasoactive agents should similarly be assessed by considering myocardial metabolism as well as simply the external work performed by the heart.

Table 3-1. Myocardial metabolism in coronary shock: mean values before and during therapeutic intervention

Measurement	Isoprenaline		Norepinephrine		Intra-aortic Balloon pump	
	Control	(2–4 μ g/min)	Control	(2–8 μ g/min)	Control	
Number of cases	6	6	8	8	10	10
Time-tension index/min (mmHg-sec/min)	1330	1529	1376	1894†	1279	969‡
Left ventricular work index (kg-m/min/m ²)	0.87	1.61†	1.08	1.68*	1.00	0.97
Arterial lactate content (mmol/litre)	4.10	3.99	5.90	6.18	5.18	3.01‡
Coronary blood flow (ml/100 g/min)	72	84	70	97‡	68	91‡
Myocardial O ₂ extraction (%)	76	71†	75	73	79	61‡
Coronary sinus O ₂ tension (mmHg)	22	22	22	22	21	26†
Myocardial lactate extraction (%)	-8	-19‡	-4	12†	-6	15‡
Myocardial lactate consumption (μ mol/100 g/min)	-23	-59†	-22	61†	-30	39‡

*p<0.05; †p<0.01; ‡p<0.001.

Title***Respiratory muscle fatigue during cardiogenic shock***

Author

Aubier M, Trippenbach T, Roussos C

Reference*J Appl Physiol* 1981; **51**: 499–508

Abstract

The effect of cardiogenic shock (tamponade) on respiratory muscle performance was studied in 13 dogs breathing spontaneously. These 13 dogs were compared with 7 dogs artificially ventilated and paralyzed. Cardiac output amounted in both groups to 25–35% of the control value and was maintained constant. None of the dogs were hypoxic. All of the spontaneously breathing dogs died on the average 140 \pm 15 min after the onset of cardiogenic shock, whereas the seven dogs artificially ventilated were all alive after 3 hours and then killed. Death in the spontaneously breathing dogs was secondary to respiratory failure. Transdiaphragmatic pressure increased during the 1st hour by 152 \pm 25% of control and then decreased by 286 \pm 18% in relation to the peak value before the death of the animals. No major changes in the mechanical properties of the respiratory system occurred. The decrease in transdiaphragmatic pressure occurred despite a marked increase per breath in the amplitude of the integrated electrical activity of the diaphragm and of the phrenic nerve. It is concluded that the ventilatory failure of cardiogenic shock is due to an impairment of the contractile process of the respiratory muscles. Artificial ventilation avoids respiratory failure and prolongs survival, which may bear important therapeutic implications.

Summary

This study investigated the effect of circulatory failure or shock on respiratory muscle performance in dogs. Thirteen spontaneously breathing dogs were compared with seven dogs that were paralyzed and artificially ventilated. In both groups, the cardiac output was reduced by >60% and held constant throughout the studies. None of the dogs were allowed to become hypoxemic, and for the three hours following this circulatory insult, ventilatory parameters and respiratory muscle performance were assessed, by measurement of transdiaphragmatic pressure and recording electromyograms from the diaphragm, intercostal, and abdominal muscles, and the electrical activity of the phrenic nerve. During the study, all the spontaneously breathing dogs died, but the seven artificially ventilated dogs survived the 3-hour protocol. Death in the spontaneously breathing dogs was secondary to respiratory failure, as reflected by the initial increase in transdiaphragmatic pressure being followed by a dramatic fall just before the death of the animals.

Citation count 238

Related references

1. Robertson CH, Foster CH, Johnson RL. The relationship of respiratory failure to the oxygen consumption of, lactate production by and distribution of blood flow among respiratory muscles during increasing inspiratory resistance. *J Clin Invest* 1977; **59**: 31–42.
2. Stainsvy WN, Otis AB. Blood flow, oxygen tension, oxygen uptake and oxygen transport in skeletal muscle. *Am J Physiol* 1964; **206**: 858–866.

Key message

Severe circulatory failure will initially promote increased respiratory work but if the underlying problem is not promptly corrected, death from secondary respiratory failure occurs. Muscle paralysis and mechanical ventilation improve prognosis by removing the work of breathing, markedly reducing the metabolic demand of the respiratory muscles and thereby the cardiac work required to supply oxygen to these muscles.

Why it's important

This study demonstrated the underlying mechanisms responsible for the secondary respiratory failure that occurs in patients with circulatory shock, and provides the rationale for early mechanical ventilation in such patients to remove the work of breathing and reduce the work load of the failing heart. In a climate when so much is specialty-driven, this demonstration of the importance of cardiorespiratory interaction is important.

Strengths

The animal model is described in detail, as are the circulatory and respiratory measurements that are made. A clear hypothesis is stated, a protocol is described, and clear results are provided with good graphical illustration.

Weaknesses

There are no details of the dogs that were ventilated and survived, and no CO_2 production or work of breathing data are provided.

Relevance

In managing the critically ill patient, this study emphasizes the important role of mechanical ventilation in supporting the failing circulation, and also the fact that weaning from ventilation will only succeed when the heart can sustain the oxygen delivery necessary to meet the metabolic requirements of the respiratory muscles.

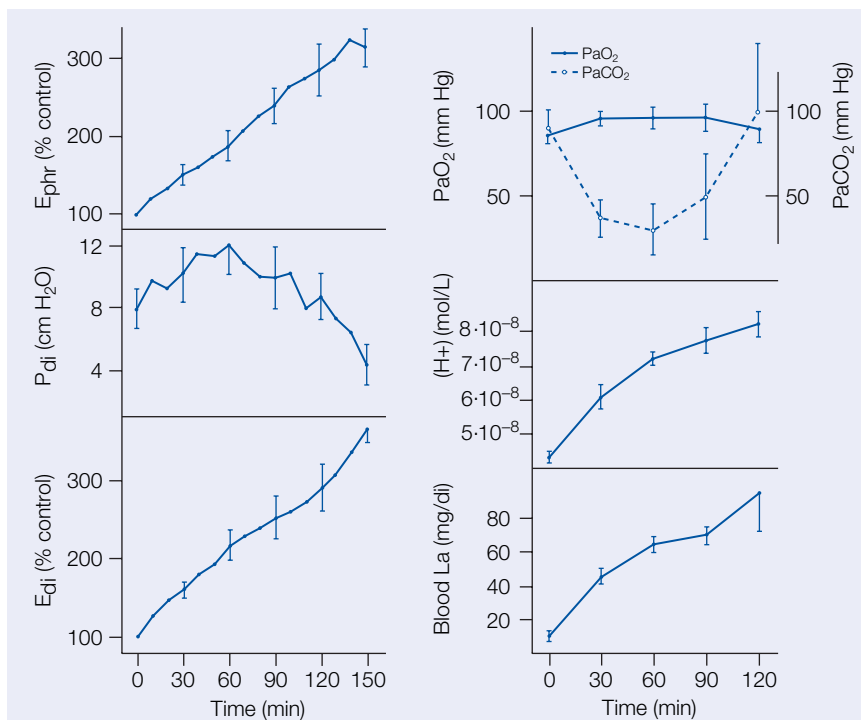

Fig. 3-14. (a) Changes in mean values of electrical integrated activity of the phrenic nerve (Ephr), transdiaphragmatic pressure (Pdi), and electrical integrated activity of the diaphragm (Edi) for 13 days breathing spontaneously following cardiac shock. (b) Time course of arterial oxygen and carbon dioxide tensions (PaO_2 , PaCO_2), mean hydrogen ion concentration ($[\text{H}^+]$), and mean arterial blood lactate (La) for 13 days breathing spontaneously. Bacs = 1 SEM.

Title

Prospective trial of supranormal values of survivors as therapeutic goals in high risk patients

Author

Shoemaker WC, Appel PL, Kram HB, Waxman K, Lee TS

Reference

Chest 1988; **94**: 1176–1186

Abstract

Survivors of high-risk surgical operations were previously observed to have significantly higher mean CI, DO₂, and VO₂ than nonsurvivors. The hypothesis was proposed that increased CI and DO₂ are circulatory compensations for increased postoperative metabolism. We tested this hypothesis in two series. In series 1, prospectively allocated by services, mortality and morbidity of the control group were significantly greater than those of the protocol group. In series 2, patients who fulfilled previously defined high-risk criteria were preoperatively randomized to one of three monitoring/treatment groups: CVP-control group, PA-control group and PA-protocol group. Postoperative mortalities in the CVP-control and PA-control groups were not statistically significantly different, but PA-protocol group mortality was significantly reduced compared with its control group. The PA-protocol group had reduced complications, duration of hospitalization, duration in ICU, and mechanical ventilation, and reduced costs when the PA catheter was placed preoperatively and used to augment circulatory responses.

Summary

A previous study had shown that survivors of high-risk surgical operations had significantly higher mean cardiac index, oxygen delivery, and oxygen consumption than nonsurvivors. This generated the hypothesis that increasing cardiac index and oxygen delivery to values defined by the survivors in the earlier study would be beneficial. These supranormal values were cardiac index (CI) >4.5 L/min/m², oxygen delivery (DO₂) >600 ml/min/m², and oxygen consumption (VO₂) >170 ml/min/m². Fluid loading and the use of a variety of vasoactive agents, predominantly dobutamine, were used to achieve these goals in the protocol group.

The study was performed as two prospectively randomized series. (i) In the first series, patients were prospectively allocated to either a protocol or control surgical team: there was a significantly higher mortality and morbidity in the control group. (ii) In the second series, patients were pre-operatively randomized, irrespective of admitting surgical team, to either CVP control, PA control, or PA protocol group.

Treatment with a PA catheter according to protocol was associated with a reduction in mortality, complications, duration of ventilation, and length of ICU and hospital stay.

Citation count

779

Related references

1. Wilson J, Woods I, Fawcett J *et al.* Reducing the risk of major elective surgery: randomised control trial of preoperative optimising of oxygen delivery. *BMJ* 1999; **318**: 1099–1103.
2. Hayes MA, Timmins AC, Yau E *et al.* Elevation of systemic oxygen delivery in the treatment of critically ill patients. *N Engl J Med* 1994; **330**: 1712–1722.

3. Connors AF, Speroff T, Dawson NV *et al.* The effectiveness of right heart catheterisation in the initial care of critically ill patients. *JAMA* 1996; **276**: 889–897.

Key message

Managing surgical patients perioperatively with a pulmonary artery catheter, and using volume loading and inotropic support to increase cardiac output and oxygen delivery to levels achieved by survivors in a previous study ('goal-directed therapy'), improves survival. The increase in oxygen delivery is associated with an increase in oxygen consumption, suggesting that a previously existing, covert oxygen debt had been relieved. However, if delayed until complications or clinical evidence of shock developed postoperatively, there was no benefit from using this protocol.

Why it's important

Shoemaker's series of publications on goal-directed therapy led to widespread belief in the 'supply dependency' of oxygen consumption in the critically ill, and resulted in a dramatic increase in PA catheter use to practice goal-directed therapy in unselected critically ill patients. The need to identify and treat intravascular volume depletion promptly was demonstrated since late treatment was ineffective, thereby emphasizing an important distinction between 'early' and 'late' shock.

Strengths

This was a large, well-designed, prospective, randomized study that provided detailed data and results and made a major contribution to the management of surgical patients.

Weaknesses

No data are provided on (i) the volume of fluid used in the two groups, (ii) the number of patients who required dobutamine as well as volume to achieve the designated goals, or (iii) the number of patients who failed to respond in the protocol group.

This information is important to assess whether (i) the benefit related largely to the adequacy of fluid resuscitation, (ii) there could have been a significant metabolic linkage caused by dobutamine stimulating both oxygen delivery and consumption, and (iii) there was a group of non-responders who may have had a poorer outcome, as has been suggested by subsequent studies.

Relevance

This evidence was over-interpreted and resulted in clinicians using 'goal-directed therapy' to treat intensive care patients who already had established shock and organ dysfunction. There ensued a vigorous debate on the relationship between oxygen delivery (DO_2) and consumption (VO_2), and whether metabolic linkage from the use of dobutamine and mathematical linkage caused by calculating both VO_2 and DO_2 using common measurements of Q_t and CaO_2 were confounding factors in many of these studies. Two major randomized control studies finally demonstrated that there was no benefit from this approach in ICU patients with established shock, and indeed suggested that it may be detrimental.

The reported increase in mortality associated with the use of pulmonary artery catheters may have in part reflected the adverse effects of their use in attempting to achieve supra-normal levels of DO_2 in an inappropriate group of patients.

This later evidence does not discredit Shoemaker's work, but reflects the dangers of over-interpretation and applying study results to a different group of patients. As far as the management of the peri-operative patient is concerned, a number of recent studies have confirmed the benefit of identifying and correcting volume depletion and poor myocardial performance at an early stage, and before late shock and organ dysfunction develops.

Table 3-2. Comparison of hemodynamic and oxygen transport values of surviving and non-surviving patients in the preoperative and post operative periods

Values	Preoperative period		Postoperative period (0–4 days)	
	Survivors (99 data sets)	Nonsurvivors (41 data sets)	Survivors (1,233 data sets)	Nonsurvivors (813 data sets)
HR (beats per minute)	91 ± 21	102 ± 23	109 ± 19†	109 ± 19.9‡
MAP (mm Hg)	99 ± 16	95 ± 22	97 ± 17	84 ± 20†
CVP (mm Hg)	6.1 ± 5.1	10.3 ± 6.7	9.2 ± 5.6†	12.0 ± 6.4
PAWP, wedge pressure (mm Hg)	8.8 ± 6.1	11.9 ± 6.5	11.6 ± 5.7†	14.5 ± 6.5‡
CI (L/min.m ²)	3.8 ± 1.2	3.6 ± 1.2	4.2 ± 1.3†	3.4 ± 1.3
LVSWI (g.m/m ²)	59 ± 20	45.9 ± 15.9	52.1 ± 2.0†	36.8 ± 19
SaO ₂ (%)	94.5 ± 3.5	94.9 ± 2.7	95.6 ± 3.1†	94.1 ± 6.8
Hct (%)	34.3 ± 5.6	31.8 ± 3.6	32.4 ± 4.9†	31.5 ± 5.5
DO ₂ (ml/min.m ²)	548 ± 162	500 ± 159	601 ± 189†	461 ± 173
VO ₂ (ml/min.m ²)	141 ± 49	135 ± 30	153 ± 41†	136 ± 46
O ₂ extraction ratio (%)	26.7 ± 8.2	28.1 ± 7.4	26.7 ± 7.2	32.0 ± 10.9†

* Values are mean ± SD.

† p<0.01 by Student's t test compared with their preoperative baseline values.

‡ p<0.05 by Student's t test compared with their preoperative baseline values.

Table 3-3. Therapeutic goals for control and protocol groups

Variable	PA-control	PA-protocol
Blood pressure (mm Hg)	>120/80	>120/80
CVP (cmN/saline)	>4 & <12	<15
Hct (%)	>35	>34
Urine output (ml/h)	>30	>30
Heart rate (beats/min)	>60 & <120	>60 & <120
PvO ₂ (mm Hg)	>40	>40
Pulmonary wedge pressure (mm Hg)	4_12	<18
Systemic vascular resistance (dyne.s/cm5.m2)	1800–2600	1450
Cardiac index (L/min.m ²)	2.8–3.5	>4.5
DO ₂ (ml/min.m ²)	400–550	>600
VO ₂ (ml/min.m2)	120–140	>170

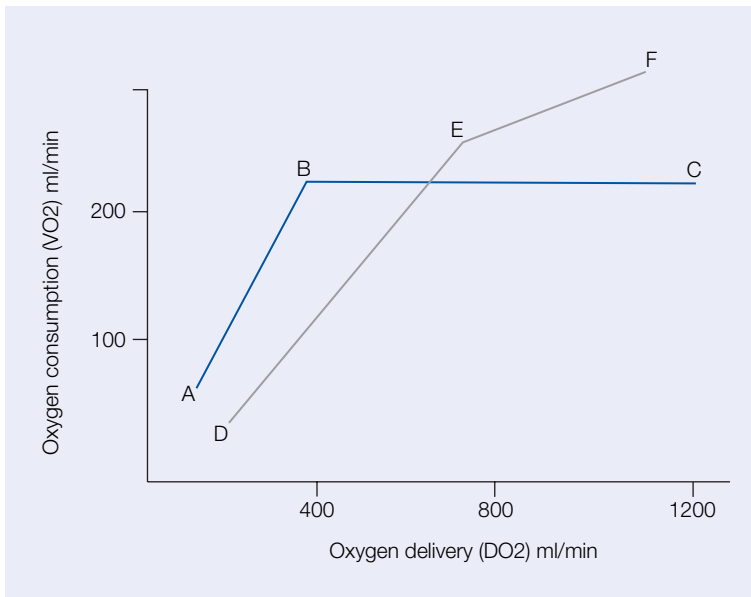

Fig. 3-15. The effects of changing oxygen delivery on consumption. The solid line ABC represents the normal relationship, and the dotted line the altered relationship believed to exist in sepsis

Severe traumatic brain injury

Hülya Bayir, Kimberly D. Statler, Margaret A. Satchell, Randall A. Ruppel, Robert S.B. Clark and Patrick M. Kochanek

Introduction

The restitution of brain function and successful achievement of good neurological outcome after acute brain injury, including severe traumatic brain injury and other encephalopathies, represents the final frontier in critical care medicine. Related to the complexity of the brain and the difficulties involved in the bedside assessment and monitoring of cerebral pathophysiology; progress in this area has been disappointing, and therapeutic breakthroughs are generally lacking. Severe traumatic brain injury, however, represents one of the most likely diseases in neurointensive care in which breakthroughs may soon be achieved. This results from the fact that in many cases, traumatic brain injury afflicts young and otherwise healthy patients. Similarly, unlike the encephalopathies of cardiopulmonary arrest and asphyxia, severe traumatic brain injury is often focal in nature. In the setting of focal injury in a relatively young and otherwise healthy patient, the successful management of the evolution of damage, along with the prevention of secondary insults and herniation, through optimal neurointensive care, can set the stage for progressive improvement in outcome as a consequence of cerebral plasticity.

Because of the lack of development of therapeutic breakthroughs for severe traumatic brain injury, the classic papers in the field are generally descriptive in nature. Our understanding of the key mechanisms of secondary damage after injury is still extremely limited, although these 'classic' papers demonstrate progress in the areas of physiology, biochemistry, and, most recently, molecular biology. Because of the importance of cerebral monitoring in optimal management of severe traumatic brain injury, several of these 'classics' describe monitoring-related 'firsts', including the first description of the Cushing response (Cushing 1901), the initial application of a brain-oriented bedside monitoring strategy – continuous intracranial pressure assessment (Lundberg *et al.* 1965), and the initial descriptions of both cranial computed tomography (Ommaya 1973), and the Glasgow coma scale score (Teasdale and Jennett 1974). However, since our ability to non-invasively assess brain pathophysiology, beyond the limitations of the neurological examination, has progressed only in the past 30 years, the remainder of the 'classic' papers, in neurointensive care of the patient with traumatic brain injury, are relatively recent. Other 'classic' descriptive studies include the investigation of the role of secondary insults at the injury scene (Chesnut *et al.* 1993), and, more recently, of key biochemical and molecular mechanisms operating in the injured human brain during treatment in the neurointensive care unit, namely excitotoxicity (Bullock *et al.* 1998), and apoptosis (Clark *et al.* 1999). Because of space limitations, several additional important descriptive studies were not presented, including Lassen *et al.* 1966; Obist *et al.* 1984; Adams *et al.* 1989; Persson and Hillered 1992; Bergsneider *et al.* 1997 and Juul *et al.* 2000, among others.

In addition to descriptive studies, a number of important therapeutic trials have been carried out. The majority of the substantial clinical trials in the field of brain trauma have been carried out in the past 20 years. Unfortunately, most of these trials have been negative. Among the most interesting and important trials, three are presented in this chapter (Seelig *et al.* 1981, Muizelaar *et al.* 1991, Robertson *et al.* 1999). In each case, valuable lessons have been learned from these 'classic' trials; specifically, the importance of early removal of mass lesions (Seelig *et al.* 1981), the complex nature of the long-standing therapeutic intervention – hyperventilation (Muizelaar *et al.* 1991) – and the multi-factorial impact of aggressive manipulation of cerebral perfusion pressure (Robertson *et al.* 1999).

Taken together, these descriptive and clinical studies reflect the important nature of the continuum of care, which spans from the field through to rehabilitation, and point to the importance of a multidisciplinary approach to these patients. Finally, these classic studies also point to the tremendous gaps in our current understanding of the complex pathobiology of the traumatically injured human brain.

References

- Adams JH, Doyle D, Ford I, Gennarelli TA, Graham DI, McLellan DR. Diffuse axonal injury in head injury: definition, diagnosis, and grading. *Histopathology* 1989; **15**: 49–59.
- Bergsneider M, Hovda DA, Shalmon E *et al*. Cerebral hyperglycolysis following severe traumatic brain injury in humans: a positron emission tomography study. *J Neurosurg* 1997; **86**: 241–251.
- Juul N, Morris GF, Marshall SB, The Executive Committee of the International Selfotel Trial, Marshall LF. Intracranial hypertension and cerebral perfusion pressure: influence on neurological deterioration and outcome in severe head injury. *J Neurosurg* 2000; **92**: 1–6.
- Lassen NA. The luxury perfusion syndrome and its possible relation to acute metabolic acidosis localized within the brain. *Lancet* 1966; **2**: 1113–1115.
- Obrist WD, Langfitt TW, Jaggi JL, Cruz J, Gennarelli TA. Cerebral blood flow and metabolism in comatose patients with acute head injury. Relationship to intracranial hypertension. *J Neurosurg* 1984; **61**: 241–253.
- Persson L, Hillered L. Chemical monitoring of neurosurgical intensive care patients using intracerebral microdialysis. *J Neurosurg* 1992; **76**: 72–80.

Title

Concerning a definite regulatory mechanism of the vasomotor centre which controls blood pressure during cerebral compression

Author

Cushing H

Reference

Johns Hopkins Hospital Bulletin 1901; **12**: 290

Abstract

Not available

Summary

This remarkable study was performed to investigate the parallel relationship between the degree of cerebral compression – produced by a saline-induced increase in intracranial pressure – and the increase in arterial blood pressure. Dogs were anaesthetized with ether, after intravenous morphine administration. Systemic arterial blood pressure was measured via femoral artery catheter. The cerebral circulation was directly assessed via a cranial window inserted through a trephine opening over the cerebrum, cerebellum, or cord. Intracranial pressure was increased by titrated infusion of a physiological salt solution through a separate trephine opening in the skull and dura. Blood pressure and intracranial pressure were recorded simultaneously, and several fundamental observations were made. First, when intracranial pressure was increased rapidly to exceed arterial blood pressure, major symptoms of compression, with partial cessation of respiration and a pronounced vagal effect on the heart, lasting between 10 and 20 seconds, were noted. This was followed by a release from vagal inhibition, and an increase in blood pressure to a level greater than intracranial pressure – sufficient to restore perfusion to the medulla (Figure 4-1). When intracranial pressure was increased slowly, the vagal symptoms were avoided, and blood pressure increased immediately and in parallel with intracranial pressure. Blood pressure increases to levels > 200 mmHg could be achieved and sustained for considerable durations – until the medullary vasomotor center failed. When the vagi were divided, even rapid compression of the medulla resulted in parallel increases in arterial blood pressure. During compression, if a loop of small intestine was exposed, the splanchnic circulation was noted to contract during the period of intracranial hypertension. When the spinal cord was divided with a blunt instrument, only the vagal effect was observed – without the concomitant increase in arterial blood pressure. Finally, when both vagi and the cord were divided, increases in intracranial pressure produced no hemodynamic effects, confirming a key role for both the cord and vagus in the ‘Cushing response’.

Citation count

295

Key message

Remarkably, Harvey Cushing in 1901 eloquently stated the key message of this report in the form of a law of neurophysiology, namely ‘*that an increase of intracranial tension occasions a rise of blood pressure which tends to find a level slightly above that of the pressure overled against the medulla*’. He went on to state that ‘*it is thus seen that there exists a regulatory mechanism on the part of the vasomotor center which, with great accuracy,*

enables the blood pressure to remain at a point just sufficient to prevent persistence of an anaemic condition of the bulb, demonstrating that the rise is a conservative act and not one such as is consequent upon a more reflex sensory irritation'.

Why it's important

The 'Cushing response' represents one of the central maxims of clinical neurointensive care. The prevention of intracranial hypertension-induced secondary brain injury, whether from vascular compression or from herniation-induced brain deformation, has remained a key facet of care for nearly one hundred years.

Strengths

1. Before this study, it was known that cerebral compression resulted in an increase in arterial blood pressure. However, this study clearly demonstrated that the magnitude of the increase in blood pressure paralleled the increase in intracranial pressure. A cause and effect relationship was also established.
2. Insight into the mechanism of this effect was clearly demonstrated in the studies of vagal and spinal cord transection.

Weaknesses

The sample size of the study was not mentioned. Similarly, no statistical analysis of the data was performed. Cushing simply reported his observations on what may have been studies in a small number of animals. Nevertheless, his observations were correct.

Relevance

The recognition and treatment of Cushing response physiology in patients after severe traumatic brain injury will remain an axiom of care in the new millennium.

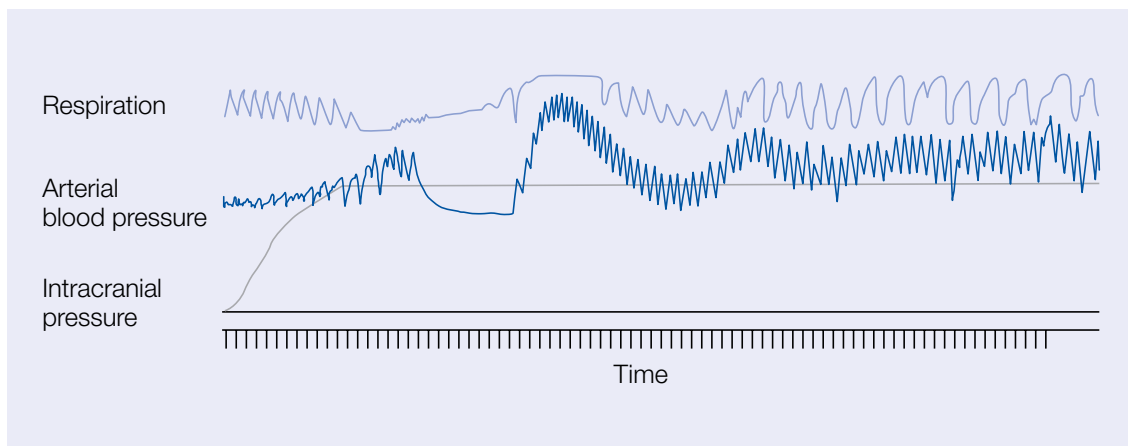

Fig. 4-1. Plot of respiratory rate, arterial blood pressure and intracranial pressure, modified from the work of Cushing in 1901. This is his original example of the effect of rapidly increasing intracranial pressure, by intracranial infusion of a physiological salt solution, on arterial blood pressure in the dog

Title

Continuous recording of the ventricular fluid pressure in patients with severe acute traumatic brain injury: a preliminary report

Author

Lundberg N, Troupp H, Lorin H

Reference

J Neurosurg 1965; **22**: 581–590

Abstract

Not available

Summary

Up to 1964, there were a number of reports of measurement of spinal fluid pressure made by lumbar puncture in cases of acute brain injury. Ryder et al. (1) measured spinal fluid pressure continuously in a few patients with acute brain injury. In the neurological surgery department in Lund, Sweden, Lundberg and colleagues described the first study of continuous recording of intracranial pressure in patients with severe traumatic brain injury. In this preliminary report, the authors described a selected number of cases from their series of 30 cases. Notably, by the early 1960s, this group had continuously measured intracranial pressure in >350 patients with a variety of brain disorders. To this end, a ventricular cannula, designed to measure pressures in a range of –10 to +115 mmHg, was used. Intracranial pressure monitoring was initiated as early as 3 hours after injury, and was maintained in some patients for as long as 9 days. Detailed descriptions of the titration of therapies (hypothermia, urea) targeting increases in the continuously monitored intracranial pressure are provided (Figure 4-2). In addition, a case of brain stem contusion with considerable symptomatology, but without increases in intracranial pressure, is described. Similarly, an early description of treatment of ‘plateau waves’ is provided.

Citation count 114

Related references

1. Ryder HW, Espey FF, Kimbell FD *et al.* The mechanism of change in cerebrospinal fluid pressure following an induced change in the volume of the fluid space. *J Lab Clin Med* 1953; **41**: 428–435.
2. Langfitt TW, Kumar VS, James HE, Miller JD. Continuous recording of intracranial pressure in patients with hypoxic brain damage. *Clin Dev Med* 1971; **39/40**: 118–135.
3. Bullock MR, Povlishock JT. Guidelines for the management of severe head injury. *J Neurotrauma* 1996; **13**: 653–734.

Key message

In contrast to the futility of single measurements of intracranial pressure, the feasibility and value of continuous intracranial pressure monitoring in patients with severe traumatic brain injury is clearly described for the first time.

Why it's important

This is the first description of the use of continuous intracranial pressure monitoring, and, at that time, offered a more rational approach to treatment of patients with severe traumatic brain injury.

Strengths

1. The paper provides a clear description of the method for continuously measuring intracranial pressure, and describes the application of this technique to several cases.
2. This report also provides an excellent historical description of 'state-of-the-art' care of patients with severe traumatic brain injury in the late 1950s and early 1960s.

Weaknesses

Presentation and analysis of the entire cohort of 30 patients is lacking in this preliminary report.

Relevance

The marked sensitivity of the brain to both secondary hypoxic-ischemic insults and physical deformation mandates the need for prompt recognition and treatment of significant intracranial hypertension. Continuous recording of intracranial pressure at the bedside remains a key element of neurointensive care of patients with severe traumatic brain injury, and this was reinforced in the published 'Guidelines for the Management of Severe Head Injury' (3).

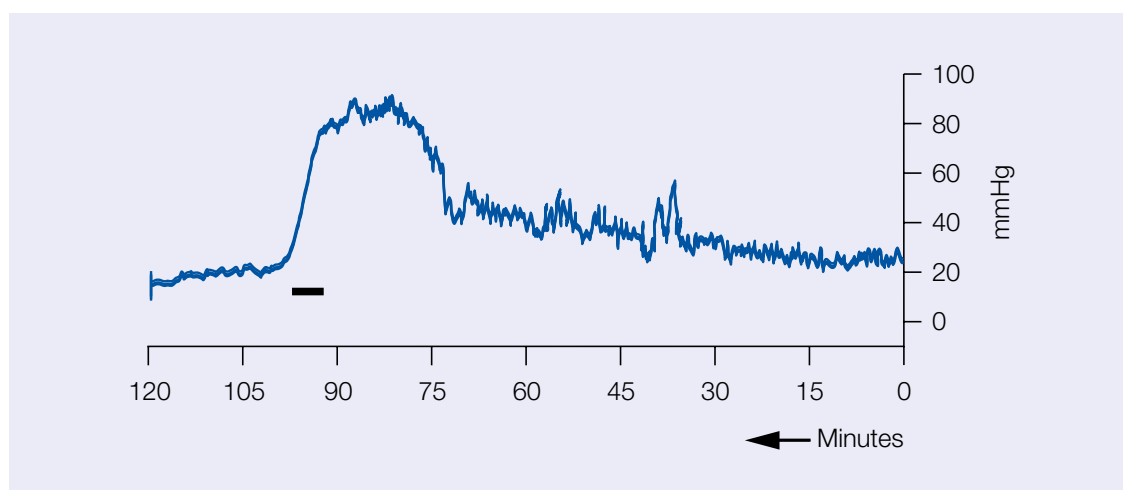

Fig. 4-2. Continuous modification of intracranial pressure at the bedside in a patient with severe traumatic brain injury from the seminal work of Lundberg *et al*. The curve, recorded 24 hours after accident, shows the basic level of intracranial pressure to be slightly above normal (high by contemporary standards). This is followed by a sudden spontaneous rise to an extremely high level (about 90 mmHg) and after about 20 minutes a rapid fall in pressure. The increase in pressure was accompanied by tonic extension of the limbs and cardiovascular disturbances; these symptoms disappeared at once when the ventricular fluid pressure decreased. The horizontal bar indicates intravenous administration of urea. The small rhythmic oscillations of the pressure curve (1-per-min waves) were related to the Cheyne-Stokes breathing of the patient

Title

Computerized axial tomography of the head: the EMI-scanner, a new device for direct examination of the brain 'in vivo'

Author

Ommaya AK

Reference

Surg Neurol 1973; **1**: 217–222

Abstract

Not available

Summary

This article represents an account of the first report of the use of cranial computed tomography by Ambrose and Hounsfield, which was presented at the November 1972 meeting of the Radiologic Society of North America. An overview of the apparatus, the general EMI-scanner unit, and the principle of operation of the scanner (Figure 4-3) are presented. The potential value of the technique is discussed, including its ability to easily distinguish brain tissue, cerebrospinal fluid, coagulated blood, and fat based on differences in x-ray absorption. Computed tomographic scans of six cases, including hydrocephalus, craniopharyngioma, glioblastoma, capsular hemorrhage, intracerebral hemorrhage, and cortical atrophy are presented (Figure 4-4). The discussion indicates that this technique is easy, requires no specific preparation of the patient, and is safe. The likelihood that pneumoencephalography, angiography, and nuclide scanning will be used much more selectively is also discussed. Finally, it is concluded that a variety of intracranial pathologies will be diagnosed and treated earlier and with much greater efficiency than has hitherto been possible.

Citation count

23

Related reference

1. Ambrose J, Hounsfield G. Computerized transverse axial tomography (abstract). *Br J Radiol* 1973; **46**: 148–149.
2. Eisenberg HM, Gary HE Jr, Aldrich EF, *et al*. Initial CT findings in 753 patients with severe head injury. A report from NIH Traumatic Coma Data bank. *J Neurosurg* 1990; **73**: 688–698.

Key message

Computed tomography of the head has great potential for non-invasive diagnosis and serial evaluation of a wide spectrum of neurological disease, including traumatic brain injury.

Why it's important

Cranial computed tomography revolutionized both the surgical and medical management of patients with severe traumatic brain injury. Along with intracranial pressure monitoring, nothing has both advanced our understanding of pathophysiology and guided treatment more than computed tomography.

Strengths

1. A comprehensive description of the method is provided, including early examples of cases relevant to the intensive care unit.
2. The paper provides an outstanding historical description of the time sequence of events involved in the development of this technique, and application to neuroradiology by Ambrose and Hounsfield in 1973.

Weaknesses

This early description could have only been strengthened had the scans been accompanied by autopsy or biopsy findings.

Relevance

In addition to its obvious breakthrough effect on clinical care of traumatic brain injury victims, standard cranial computed tomography set the stage for the development of additional important embellishments of this technique, such as stable xenon computed tomography for the coupled assessment of cerebral blood flow. The development of computed tomography also set the stage for a number of important future reports of the use of this technique in severe traumatic brain injury, such as the work of Eisenberg *et al.* (2). Despite its critical role during the past 25 years, it is likely that as technological advances in magnetic resonance imaging methods progress, the role of computed tomography will gradually diminish.

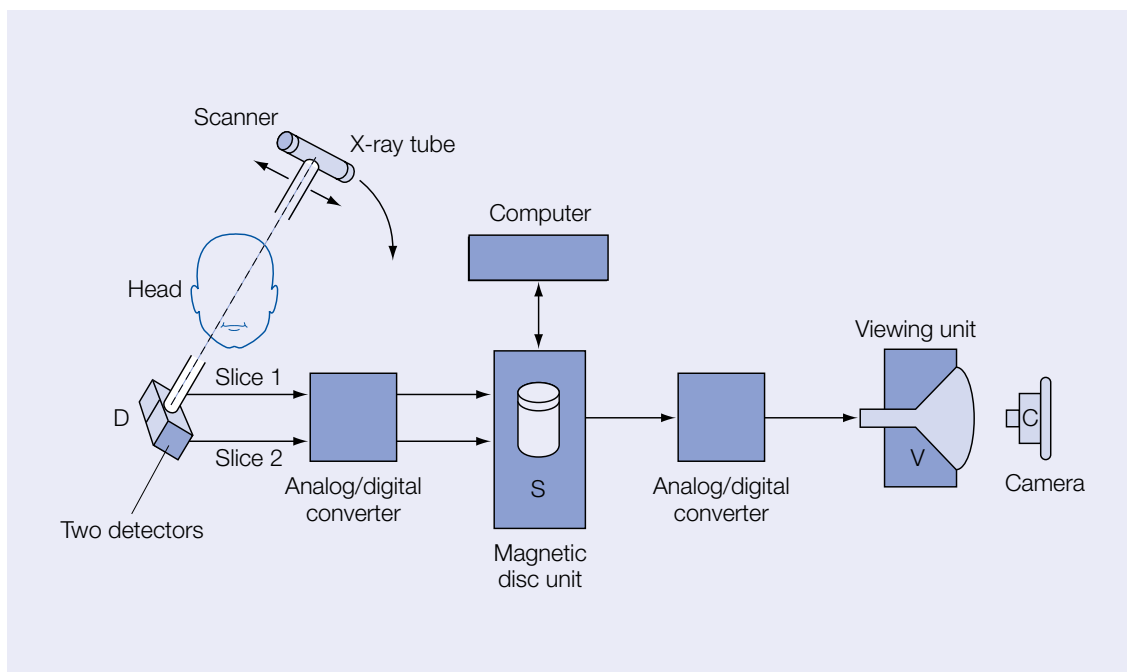

Fig. 4-3. Principle of operation of the EMI scanner system as described by Ommaya in this early report of computed tomography of the brain. The X-ray tube sends a beam of photons through the head that are detected on the other side by two photo-multiplier tubes. A magnetic disc unit receives their output; from this, the computer produces the processed digital information. The computer data are converted into analog format for presentation on a cathode ray oscilloscope viewing unit, where they are photographed by a Polaroid camera

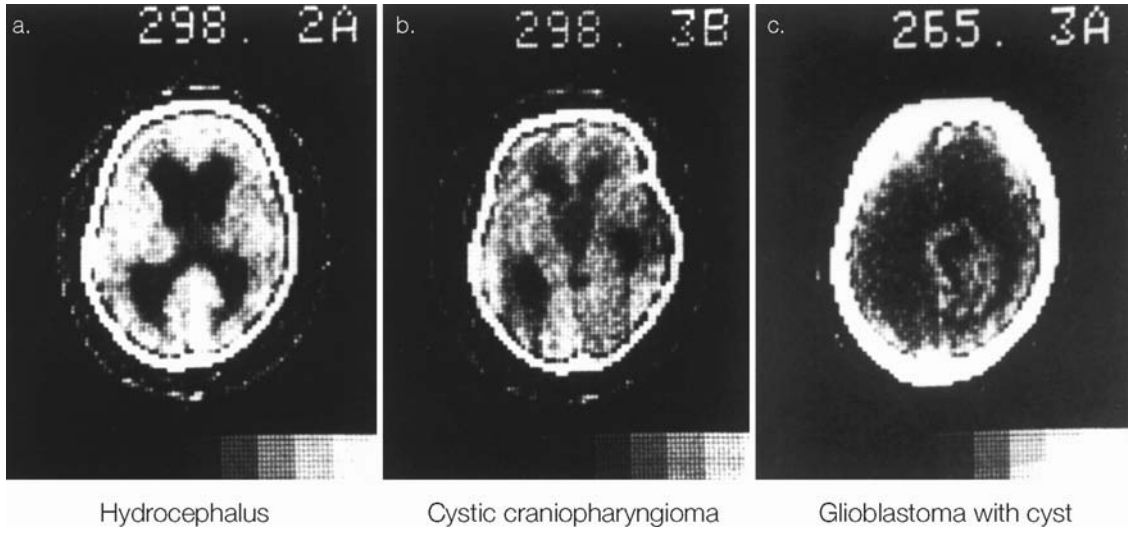

Fig. 44. Some of the first examples of cranial computed tomography obtained in three patients with (a) hydrocephalus, (b) cystic craniopharyngioma and (c) glioblastoma

Title

Assessment of coma and impaired consciousness: a practical scale

Author

Teasdale G, Jennett B

Reference

Lancet 1974; **2**: 81–84

Abstract

A clinical scale has been evolved for impaired consciousness and coma. Three aspects of behavior are independently measured – motor responsiveness, verbal performance, and eye opening. These can be evaluated consistently by doctors and nurses and recorded on a simple chart which has proved practical both in a neurosurgical unit and in a general hospital. The scale facilitates consultations between general and special units in cases of recent brain damage, and is useful also in defining the duration of prolonged coma.

Summary

The authors indicate that there are a number of systems for describing impaired levels of consciousness or coma. However, none of these are consistent, and most clinicians 'retreat from any formal scheme in favor of a general description of the patient's state'. To be able to assess and record changing states of altered consciousness reliably, for repeated bedside application to the monitoring and treatment of a wide range of conditions, the authors describe a practical scale with motor, verbal, and eye opening components. This consistency, and ease of application of this tool, was then demonstrated by having several groups of doctors and nurses examine the same group of patients. In this setting, the authors describe that disagreements were rare. The authors compared the use of this scale to the attempted characterization of patients by clinicians as either conscious or unconscious. In the latter setting, a 20% disagreement rate was reported. Although the authors describe unusual cases where selected aspects of this scale could not be assessed (such as the locked-in syndrome), they point out the willingness of the nurses in their intensive care unit to record this scale similar to the conventional recording of temperature, respiration, and pupil size (Figure 4-5). The application of this scale to use in a general hospital – one that frequently admits patients with head injuries – is also described.

Citation count

3791

Related reference

1. Marion DW, Carlier PM. Problems with initial Glasgow coma scale assessment caused by prehospital treatment of patients with head injuries: results of a national survey. *J Trauma* 1994; **36**: 89–95.

Key message

Repeated, reliable assessment of changing states of altered consciousness, at the bedside, can be readily achieved by a wide range of observers without the need for a complete neurological examination.

Why it's important

This is the initial description of the Glasgow coma scale score, which has become the standard tool for the initial categorization and serial assessment of patients with acute brain injury and impaired consciousness.

Strengths

1. A clear and simple description of the scoring system is provided.
2. Interesting perspective is provided on the state of the ability to assess level of impairment in consciousness in the late 1960s, along with a description of the remarkable discord that existed before this report.

Weaknesses

Remarkably, the authors provided only a description of the tool without a presentation of data validating, or even supporting, its use. Only very limited anecdotal reports are provided that indicate that this score 'appears to work' (when applied in several different units) and is 'accepted for bedside use by nursing staff'.

Relevance

Despite inherent difficulties with assessment of patients at the injury scene, and confounding effects of sedation and paralysis of patients before evaluation in the emergency department (1), the Glasgow coma scale has been validated and has been shown to be of considerable prognostic value. It has withstood the test of time, and has been the standard of care in the assessment of impaired consciousness for over 25 years.

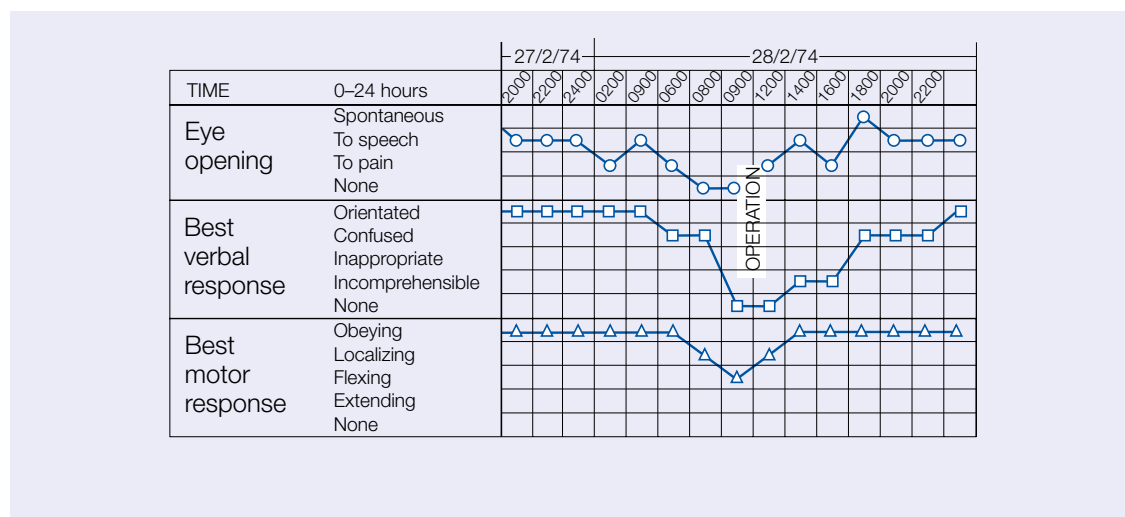

Fig. 4-5. Initial example, from the work of Teasdale and Jennett, of the bedside chart used to record the Glasgow coma scale score in a patient with severe traumatic brain injury

Title

The role of secondary brain injury in determining outcome from severe head injury

Author

Chesnut RM, Marshall LF, Klauber MR, Blunt BA, Baldwin N, Eisenberg HM, Jane JA, Marmarou A, Foulkes MA

Reference

J Trauma 1993; **34**: 216–222

Abstract

As triage and resuscitation protocols evolve, it is critical to determine the major extracranial variables influencing outcome in the setting of severe head injury. We prospectively studied the outcome from severe head injury (Glasgow coma scale score ≤ 8) in 717 cases in the Traumatic Coma Data Bank. We investigated the impact on outcome of hypotension (Systolic Blood Pressure < 90 mmHg) and hypoxia ($\text{PaO}_2 \leq 60$ mmHg or apnea or cyanosis in the field) as secondary brain insults, occurring from injury through resuscitation. Hypoxia and hypotension were independently associated with significant increases in morbidity and mortality from severe head injury. Hypotension was profoundly detrimental, occurring in 34.6% of these patients, and associated with a 150% increase in mortality. The increased morbidity and mortality related to severe trauma to an extracranial organ system appeared primarily attributable to associated hypotension. Improvements in trauma care delivery over the past decade have not markedly altered the adverse influence of hypotension. Hypoxia and hypotension are common and detrimental secondary brain insults. Hypotension particularly, is a major determinant of outcome from severe head injury. Resuscitation protocols for brain-injured patients should assiduously avoid hypovolemic shock on an absolute basis.

Summary

Following in the footsteps of the initial work of Miller and Becker in 1982, the authors took advantage of the newly developed Traumatic Coma Data Bank to further clarify the role of secondary insults on outcome after severe traumatic brain injury. In this study of over 700 cases from four clinical centers, and using an operational definition of severe traumatic brain injury as a Glasgow coma scale score of < 8 on admission or during the ensuing 48 hours, a powerful association between hypotension (systolic blood pressure < 90 mmHg) and poor outcome was demonstrated. This effect of hypotension was independent of age. A lesser, albeit significant, association between hypoxemia (an arterial PaO_2 of < 60 mmHg or as definite apnea or cyanosis) and poor outcome was also demonstrated. However, the importance of hypoxemia was more evident in younger patients. The combination of hypotension and hypoxemia at any point from the time of injury through resuscitation in the emergency department was particularly detrimental, and was associated with a 75% mortality rate (Table 4-1). Finally, the frequency of occurrence of secondary insults was reported to be 45.6% for hypoxemia, and 34.6% for hypotension.

Citation count 565

Related reference

1. Miller JD, Becker DP. Secondary insults to the injured brain. *J R Coll Surg Edinb* 1982; **27**: 292–298.

Key message

Secondary hypotensive and hypoxemic insults occur in over one-third of patients with severe traumatic brain injury, and are powerfully associated with poor outcome. Hypotension appears to be the most important extracerebral determinate of poor outcome and therapeutic target for field and emergency department resuscitation.

Why it's important

This paper has become one of the most frequently cited works on the optimal emergency management of patients with severe traumatic brain injury. It clearly documents the important detrimental associations between hypotension, hypoxemia, and their combination, and outcome of the traumatic brain injury victim.

Strengths

1. The authors used the extensive Traumatic Coma Data Bank database.
2. An assessment of the independence of the individual secondary brain insults was provided.

Weaknesses

1. The descriptive study design limits the ability to necessarily conclude that treatment of hypotension and/or hypoxemia would improve outcome.
2. Difficulties in accurately assessing the level of hypoxemia in the field may make the conclusion of this work less secure for hypoxemia than for hypotension.

Relevance

This paper not only defines the frequency of secondary insults in patients with severe traumatic brain injury, but also clarifies their relationship to outcome. This work strongly supports the concept that optimal field resuscitation of the traumatic brain injury victim will be critical in minimizing the subsequent evolution of damage, and optimizing outcome. This study strongly supports the need for application of both standard and novel therapies in the field and emergency department to optimize outcome.

Table 4-1. Data from the work of Chesnut et al. showing the powerful detrimental effect of hypotension, hypoxemia and/or their combination on outcome from traumatic brain injury (Traumatic Coma Data Bank (TCDB) data: outcome by secondary insult at time of arrival at TCDB hospital emergency department for non-mutually exclusive insults)

Secondary insults	Number of patients	Percentage of total patients	Good or moderate	Outcome percentage	
				Severe or vegetative	Dead
Total cases	699*	100.0	42.9	20.5	36.6
Neither	456	65.2	51.1	21.9	27.0
Hypoxia	130	18.6	29.2	20.8	50.0
Hypotension	165	23.6	19.4	15.8	64.8
Both	52	7.4	5.8	19.2	75.0

Hypoxia = PaO₂ <60 mmHg; hypotension = SBP <90 mmHg.

*The total number of patients is 699 instead of 717 because admission data on blood pressure or arterial blood gas values were missing for 18 patients.

Title

Factors affecting excitatory amino acid release following severe human head injury

Author

Bullock R, Zauner A, Woodward JJ, Myseros J, Choi SC, Ward JD, Marmarou A, Young HF

Reference

J Neurosurg 1998; **89**: 507–518

Abstract

Object. Recent animal studies demonstrate that excitatory amino acids play a major role in neuronal damage after brain trauma and ischemia. However, the role of excitatory amino acids in patients who have suffered severe head injury is not understood. Excess quantities of glutamate in the extracellular space may lead to uncontrolled shifts of sodium, potassium, and calcium, disrupting ionic homeostasis, which may lead to severe cell swelling and cell death. The authors evaluated the role of excitatory amino acids in human traumatic brain injury. *Methods.* In 80 consecutive severely head-injured patients, a microdialysis probe was placed into the gray matter, along with a ventriculostomy catheter or an intracranial pressure monitor, for 4 days. Levels of excitatory amino acids and structural amino acids were analyzed using high-performance liquid chromatography. Multifactorial analysis of the amino acid pattern was performed, and its correlations with clinical parameters and outcome were tested. The levels of excitatory amino acids were increased up to 50 times normal in 30% of the patients and were significantly correlated to levels of structural amino acids both in each patient, and across the whole group ($p < 0.01$). Secondary ischemic brain injury and focal contusions were most strongly associated with high excitatory amino acid levels ($27 \pm 22 \mu\text{mol/L}$). Sustained high intracranial pressure and poor outcome were significantly correlated to high levels of excitatory amino acids (glutamate $> 20 \mu\text{mol/L}$; $p < 0.01$). *Conclusions.* The release of excitatory amino acids is closely linked to the release of structural amino acids, and may thus reflect nonspecific development of membrane micropores, rather than presynaptic neuronal vesicular exocytosis. The magnitude of excitatory amino acids release in patients with focal contusions and ischemic events may be sufficient to exacerbate neuronal damage, and these patients may be the best candidates for treatment with glutamate antagonists in the future.

Summary

Eighty severely head-injured adults were monitored by microdialysis for excitatory and structural amino acids. The microdialysis probe was placed in the area of a contusion when the patients went to the operating room, or along with the ventriculostomy. Excitatory amino acid concentrations were correlated to ischemic events, computed tomography scan findings, intracranial pressure/cerebral perfusion pressure, and outcome (Figures 4-6 and 4-7). Four patterns of excitatory amino acids were described. In all cases, the structural amino acid concentrations varied in a similar pattern to the excitatory amino acids. The first pattern was a declining level of excitatory amino acids, eventually returning to normal, seen in patients with low levels of glutamate ($< 5 \mu\text{mol/L}$). This pattern was usually seen in patients with normal computed tomography scans and no ischemic events. The second pattern was seen in patients with intermediate levels of excitatory amino acids (glutamate $5\text{--}20 \mu\text{mol/L}$), and showed heterogeneous changes, usually declining, but never returning to normal. These patients usually had ischemic events or

increased intracranial pressure. The third pattern was demonstrated in patients with high levels of excitatory amino acids (glutamate $>20 \mu\text{mol/L}$), and also showed heterogeneous changes. However, a progressive rise in excitatory amino acid concentrations was seen exclusively in patients who died. All patients with high levels of excitatory amino acids had ischemic events or intracranial hypertension. The fourth pattern was also seen in the patients with high glutamate concentrations. These patients had unexplained massive increases in excitatory amino acids. In all of these cases, the microdialysis probe was in the area of the contusion. When excitatory amino acid levels were correlated with computed tomography findings, the highest concentrations were noted in patients with contusions, followed by patients with diffuse injury, and lowest with subdural or epidural hematomas. Excitatory amino acid concentrations also correlated with intracranial pressure, with higher levels seen in patients with intracranial hypertension.

Citation count 176

Related references

1. Faden AI, Demediuk P, Panter SS, Vink R. The role of excitatory amino acids and NMDA receptors in traumatic brain injury. *Science* 1989; **244**: 798–800.
2. Obrenovitch TP, Urnejak J. Is high extracellular glutamate the key to excitotoxicity in traumatic brain injury? *J Neurotrauma* 1997; **14**: 677–698.
3. Choi DW. Ionic dependence of glutamate neurotoxicity. *J Neurosci* 1987; **7**: 369–379.

Key message

Specific patterns of excitatory amino acid concentrations in the brain can be correlated to certain clinical factors. In particular, ischemic events or intracranial hypertension are associated with rises in interstitial excitatory amino acid levels. Also, high concentrations are seen when microdialysis is performed within a contusion. Finally, poor outcome is associated with increased excitatory amino acid concentrations. The finding that structural amino acids rise in conjunction with the excitatory amino acids implies that these substances are probably released from the cell through disruption of the cell membrane, as opposed to vesicular release.

Why it's important

There is a long, rich history describing the role of excitotoxicity in secondary damage after experimental brain injury. Excessive stimulation of neurons by excitatory amino acids (particularly glutamate) causes cell death in experimental settings, and has long been felt to play a key role in secondary damage after traumatic brain injury in humans. However, this is the first study in traumatic brain injury to show that specific patterns of excitatory amino acids are linked to clinical factors. In addition, it is the most comprehensive clinical study of excitotoxicity in severe traumatic brain injury. No clinical trial of anti-excitotoxic therapy has been successful, and one criticism of these trials is that patients were not stratified. This study provides a logical means for stratifying patients, and potentially identifying which subsets of patients may benefit from excitotoxicity-directed therapy. Finally, with the finding that structural amino acids are increased along with the excitatory amino acids, this study supports cell disruption as a cause of the origin of high glutamate levels after brain injury.

Strengths

1. This paper provides an excellent description of excitatory amino acid patterns that have clinical relevance and mechanistic feasibility. The number of patients is relatively large for a clinical study of traumatic brain injury (80 patients), and the techniques used in the study

are state-of-the-art. An impressive number of biochemical measurements are performed in each patient, with a thorough consideration of all patient variables that are important.

2. The correlations between biochemical measurement and patient profiles are logical, and support a role for excitation as a factor in secondary brain injury.

Weaknesses

1. Excitotoxicity is accepted as a mechanism of secondary neuronal damage following traumatic brain injury, although a cause and effect relationship has never been proven in humans. It is possible that the increases in amino acids that are measured result from cell disruption, and do not contribute to cellular damage (2).

2. By comparing between patients, this study emphasizes that important regional variations in excitatory amino acid concentrations exist within the injured brain. The lack of ability to simultaneously obtain microdialysis samples from a number of sites within a given patient is, thus, a limitation.

Relevance

As described above, the findings in this study may be used to guide future trials of anti-excitotoxic therapy. Also, the timing of therapy can be targeted to specific periods of increased glutamate concentration. Finally, this work strongly implicates the need to investigate surrogate biochemical markers, and to assess brain pharmacodynamics of contemporary and novel therapies – such as anti-excitotoxic agents, antioxidants, sedatives, and hypothermia, among other therapies.

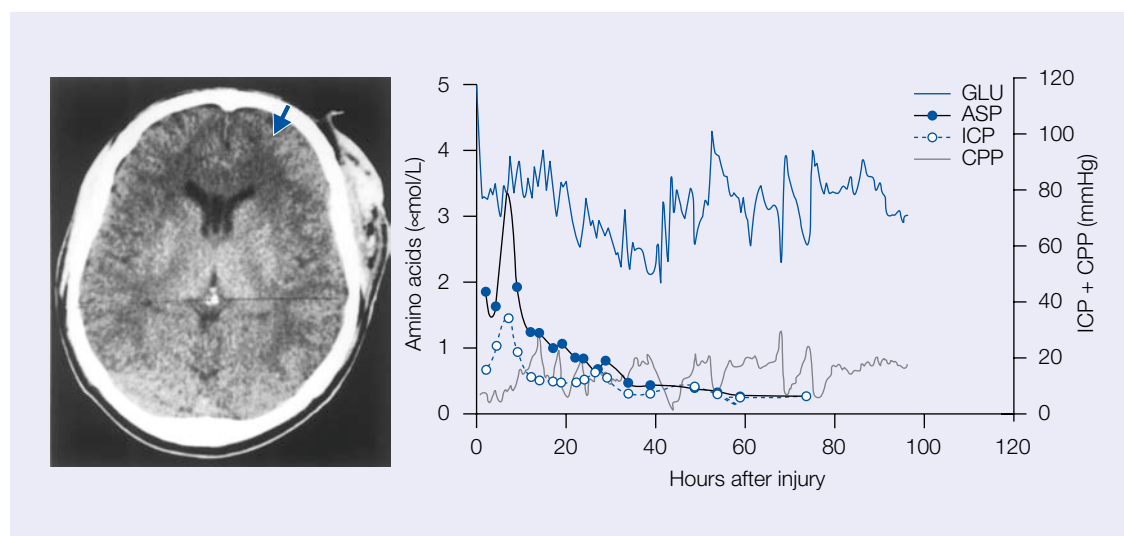

Fig. 4-6. Graph of brain interstitial excitatory amino acid (EAA) concentrations (assessed by cerebral microdialysis) and related physiology in a 24-year-old patient with diffuse injury, from the work of Bullock et al. The relationships among the dialysate EAAs (glutamate [GLU] and aspartate [ASP]), intracranial pressure (ICP) and cerebral perfusion pressure (CPP) are shown over time (normal glutamate level is $<2 \mu\text{mol/L}$). Left: Computerized tomography scan demonstrating the site of the microdialysis probe (arrow). Right: Graph displaying measurements of GLU, ASP, ICP and CPP. Note that the EAAs remained in the 'normal range' during most of the monitoring period in this patient with diffuse injury

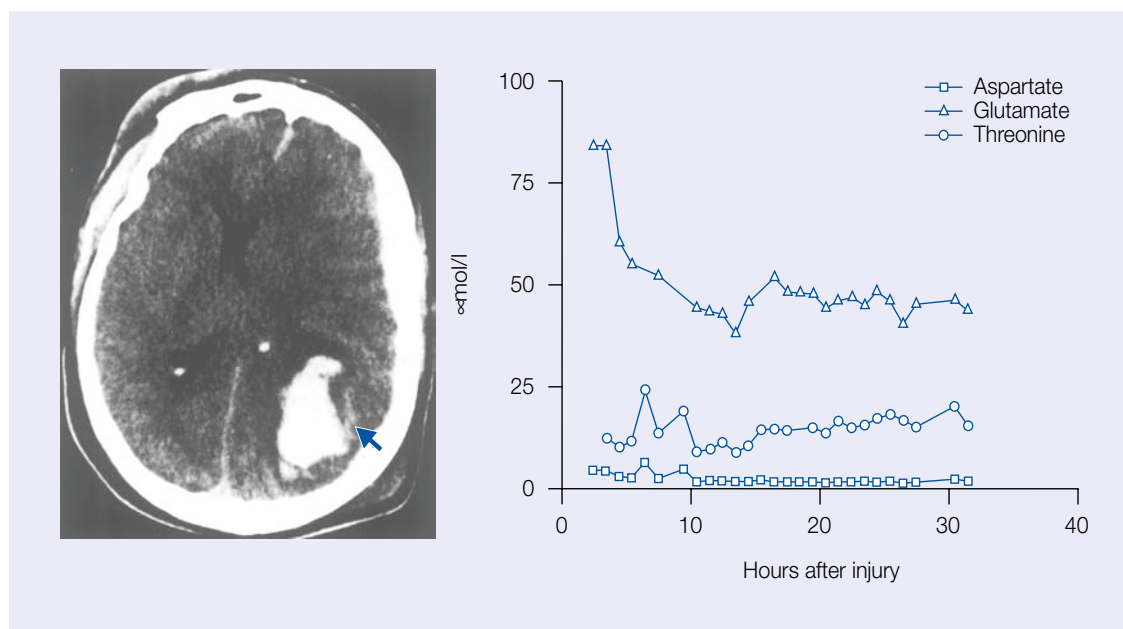

Fig. 4-7. Graph, again from the work of Bullock, showing typical 'decline and stable baseline' pattern of very high excitatory amino acids (EAAs) in a patient with focal contusions at the probe placement site. The patient made a good recovery. Left: Preoperative computed tomographic scan showing a right hemisphere subdural hematoma and focal hemorrhagic contusion. The microdialysis probe was placed in position (arrow) after the hemorrhagic contusion was evacuated. Right: Graph displaying the pattern of dialysate EAA and structural amino acid changes over 30 hours of monitoring. Note that glutamate was approximately 25 times higher than the normal value of $<2 \mu\text{mol/L}$. Figures 4-6 and 4-7 demonstrate the marked contrast in the excitotoxic response between diffuse injury and focal contusion, respectively

Title

Increases in Bcl-2 and cleavage of caspase-1 and caspase-3 in human brain after head injury

Author

Clark RSB, Kochanek PM, Chen M, Watkins SC, Marion DW, Chen J, Hamilton RL, Loeffert JE, Graham SH

Reference

FASEB J 1999; **13**: 813–821

Abstract

The Bcl-2 and caspase families are important regulators of programmed cell death in experimental models of ischemic, excitotoxic, and traumatic brain injury. The Bcl-2 family members Bcl-2 and Bcl-x_L suppress programmed cell death, whereas Bax promotes programmed cell death. Activated caspase-1 (interleukin-1 β converting enzyme) and caspase-3 (Yama/Apopain/Cpp32) cleave proteins that are important in maintaining cytoskeletal integrity and DNA repair, and activate deoxyribonucleases, producing cell death with morphological features of apoptosis. To address the question of whether these Bcl-2 and caspase family members participate in the process of delayed neuronal death in humans, we examined brain tissue samples removed from adult patients during surgical decompression for intracranial hypertension in the acute phase after traumatic brain injury (n = 8), and compared these samples to brain tissue obtained at autopsy from non-trauma patients (n = 6). An increase in Bcl-2 but not Bcl-x_L or Bax, cleavage of caspase-1, up-regulation and cleavage of caspase-3, and evidence for DNA fragmentation with both apoptotic and necrotic morphologies were found in tissue from traumatic brain injury patients compared with controls. These findings are the first to demonstrate that programmed cell death occurs in human brain after acute injury, and identify potential pharmacological and molecular targets for the treatment of human head injury.

Summary

Programmed cell death, or apoptosis, had been shown to occur in several experimental models of traumatic brain injury, but had not yet been reported in humans after acute brain injury. Brain tissue removed from patients (n = 8) with severe head injury as part of the clinical management of intracranial hypertension between August 1995 and November 1996 was stored at -70°C , then batch analyzed. The average age of the patients was 35.9 ± 4.4 years, the median admission Glasgow Coma Score was 5.5 (range 3–15), six were male, seven survived, and the median time after injury was 1 day (range 1–9). Samples from patients dying of causes unrelated to central nervous system trauma were used as controls (n = 6). Expression of the apoptosis-related proteins Bcl-2, Bcl-x_L, Bax, caspase-1, and caspase-3 was examined by Western blot analysis and immunocytochemistry. The finding that both caspase-1 and caspase-3, which exist as inactive zymogens, and require proteolytic processing for activation, were cleaved in tissue from head-injured patients but not controls suggested that both the inflammatory and apoptotic cascades were initiated (Figure 4-8). Further, the anti-apoptotic protein Bcl-2, but not the anti-apoptotic protein Bcl-x_L nor the pro-apoptotic protein Bax, was increased in tissue from head-injured patients compared with controls (Figure 4-9), suggesting that genes that regulate apoptosis are altered in the brain after acute injury. Finally, cells with apoptotic morphologies and evidence of DNA fragmentation provided histological evidence of programmed cell death after head injury in humans.

Citation count 81

Related references

1. Clark RSB, Kochanek PM, Adelson PD et al. Increases in bcl-2 protein in cerebrospinal fluid and evidence for programmed-cell death in infants and children following severe traumatic brain injury. *J Pediatr* 2000; **137**: 197–204.
2. Henshall DC, Clark RSB, Adelson PD, Chen M, Watkins SC, Simon RP. Alterations in bcl-2 and caspase gene family protein expression in human temporal lobe epilepsy. *Neurology* 2000; **55**: 250–257.

Key message

Similar to animal models, as a consequence of severe head injury in humans, the programmed cell death cascade is triggered in injured brain.

Why it's important

Since programmed cell death occurs in a delayed fashion, therapies targeting programmed cell death administered after injury may reduce neuronal cell death and improve neurological outcome after severe head injury.

Strengths

This was the first report demonstrating participation of several key steps in the programmed cell death cascade in brain in any human disease.

Weaknesses

The study had a relatively small sample size and was purely descriptive, thus, cause-and-effect was not demonstrated.

Relevance

The results of this study demonstrate the highly conserved nature of the programmed cell death cascade among species. Homologues of the Bcl-2 and caspase gene families have now been described in worms, rodents, and humans. These findings also support continued development of therapies aimed at attenuating apoptotic cell death after brain injury, and hopefully will provide impetus for a clinical trial when clinically relevant drugs become available.

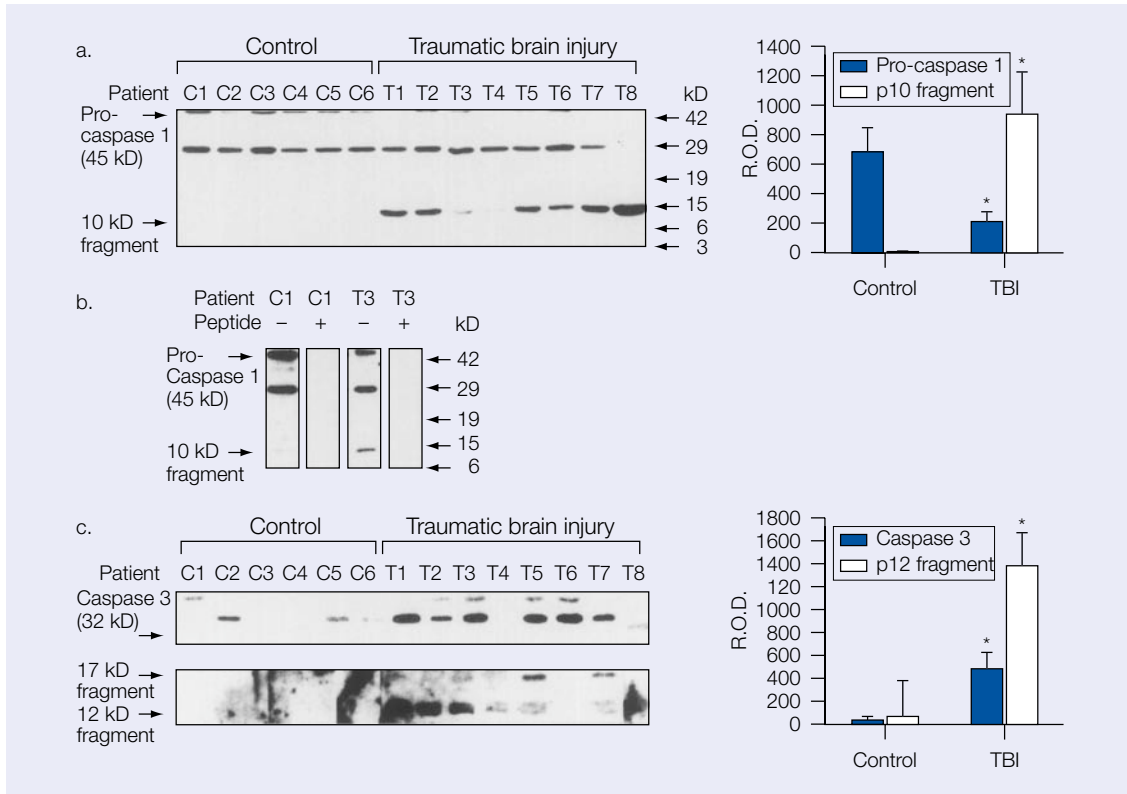

Fig. 4-8. Caspase-1 and caspase-3 protein expression in patients after traumatic brain injury (TBI), from the work of Clark et al (a) Pro-caspase-1 was reduced in patients after TBI compared with controls. Caspase-1 is also known as interleukin-1-converting enzyme – a key initiator of the acute inflammatory response. Caspase-3 is a key effector of delayed neuronal death by apoptosis. The p10 fragment of caspase-1 was increased in patients after TBI compared with controls. (b) Preabsorption studies using the anti-caspase-1 p10 antibody incubated with or without the peptide used to generate the antibody. (c) Both caspase-3 and the p12 fragment of caspase-3 were increased in patients after TBI compared with controls (there was insufficient sample to perform Western analysis using the polyclonal antibody against caspase-3 in patient T6). * $p < 0.05$ vs control, Mann-Whitney rank sum test; ROD, relative optical density

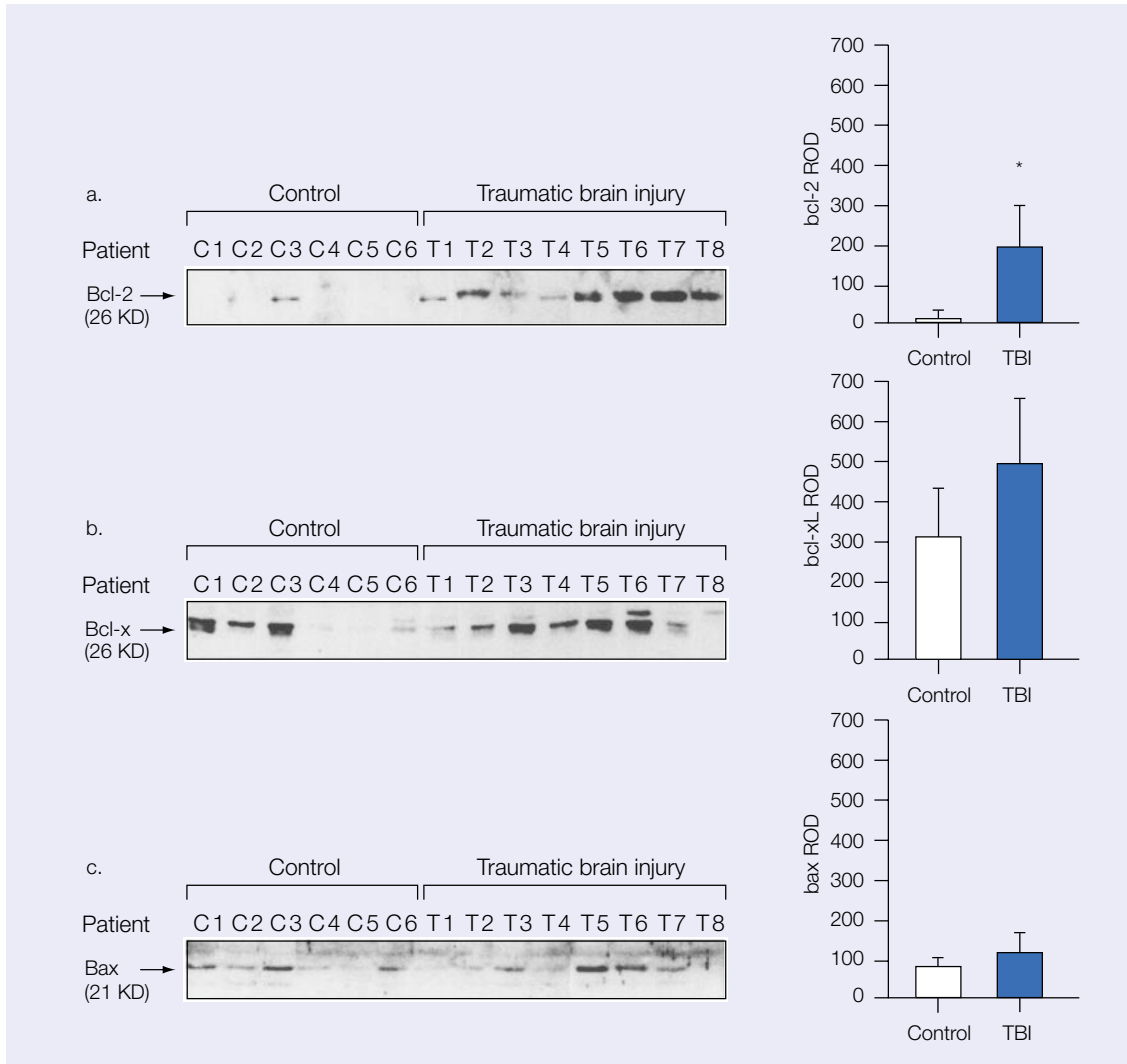

Fig. 4-9. *Bcl-2* family protein expression in patients after traumatic brain injury (TBI), again from the work of Clark et al *Bcl-2* is a powerful anti-apoptotic defence protein in the mitochondrial membrane. (a) *Bcl-2* protein was minimally detected in control patients and was increased in patients after TBI compared with controls. (b and c) Relative levels of *Bcl-x_L* and *Bax* protein were detected in many control patients and were not different in patients after TBI compared with controls. * $p < 0.05$ vs control, Mann-Whitney rank sum test; ROD, relative optical density

Title

Traumatic acute subdural hematoma

Author

Seelig JM, Becker DP, Miller JD, Greenberg RP, Ward JD, Choi SC

Reference

N Engl J Med 1981; **304**: 1511–1518

Abstract

To discover which factors contributed to recovery after surgical intracranial decompression, we reviewed the records of 82 consecutive comatose patients with traumatic acute subdural hematoma who were treated in a single center under a uniform protocol. The delay from injury to operation was the factor of greatest therapeutic importance. Patients who underwent surgery within the first four hours had a 30 percent mortality rate, as compared with 90 percent in those who had surgery after four hours ($p < 0.0001$). Other important prognostic variables included results of the initial neurologic examination, sex, multimodality-evoked potentials, and postoperative intracranial pressure. If all patients with traumatic acute subdural hematoma were taken directly to hospitals equipped to diagnose and remove the hematoma within four hours of injury, mortality rates could be reduced considerably.

Summary

A retrospective study of 82 patients over 2 years old admitted between 1972 and 1980 with traumatic acute subdural hematoma was conducted. All patients were comatose with a >5 mm midline brain shift, and all were treated with surgical decompression. Management included hyperventilation to PaCO₂ between 25 and 30 mmHg, dexamethasone, and phenobarbital for all patients. Also, mannitol was given to all patients after diagnosis of surgical mass lesion by computed axial tomography or air ventriculography. Surgical management involved rapid temporal craniectomy with partial evacuation of the hematoma before craniotomy. A ventricular catheter or subarachnoid screw was placed for intracranial pressure monitoring. Intracranial hypertension was treated with hyperventilation, cerebrospinal fluid drainage, mannitol, and/or barbiturates. Evoked potential studies, including auditory and cortical somatosensory and visual evoked potentials, were performed in 40 patients. Mortality rate was 57% in patients with traumatic acute subdural hematoma. The patients with subdural hematoma were older than those with other types of head injuries, and had worse neurological exams on admission (higher incidence of unreactive pupils, absent oculocephalic reflex, and decerebrate posturing). Among the patients with subdural hematoma, men had a higher mortality rate than women, as did patients with refractory intracranial pressure. When the time from injury until surgery was considered, the survivors went to surgery on average 3 hours earlier than non-survivors (Figure 4-10). By a multivariate analysis, the factors that correlated with outcome in patients with acute subdural hematoma were sex, intracranial pressure, initial neurological exam results, and time to surgery.

Citation count

298

Related references

1. Wilberger JE, Harris M, Diamond DL. Acute subdural hematoma: morbidity, mortality, and operative timing. *J Neurosurg* 1991; **74**: 212–218.
2. Lobato RD, Rivas JJ, Gomez PA *et al*. Head-injured patients who talk and deteriorate into coma. Analysis of 211 cases studied with computerized tomography. *J Neurosurg* 1991; **75**: 256–261.

Key message

Surgical removal of acute subdural hematomas that cause mass effect within the first 4 hours after injury can dramatically improve outcome.

Why it's important

This is one of the few interventions in the management of patients with head trauma that has actually been proven to favorably affect outcome. This study served as an impetus for more aggressive and rapid surgical intervention in the management of traumatic brain injury, and highlighted the importance of minimizing secondary brain ischemia by removing mass lesions and necrotic tissue. Also, the importance of intervention as early as possible following the injury has been a recurring theme in many aspects of brain injury research.

Strengths

1. This study involved a relatively large number of patients for a single-center, clinical study involving a subset of head injury patients.
2. A very thorough evaluation of patient factors was performed, with state-of-the-art statistical analysis (multivariate regression), particularly in light of being published in 1981.
3. Many of the management practices involved in the care of the patients in the study are contemporary to current practice.

Weaknesses

1. This is a retrospective study over a long period of time. It is likely that patient management varied significantly during the study period.
2. The discussion did not speculate on the mechanism(s) that may be involved in the improved mortality rate with early surgical removal of subdural hematoma.

Relevance

The practice of early, rapid intervention for traumatic mass lesions was greatly influenced by this study. It emphasizes the influence that the first few hours following traumatic brain injury have on the overall outcome.

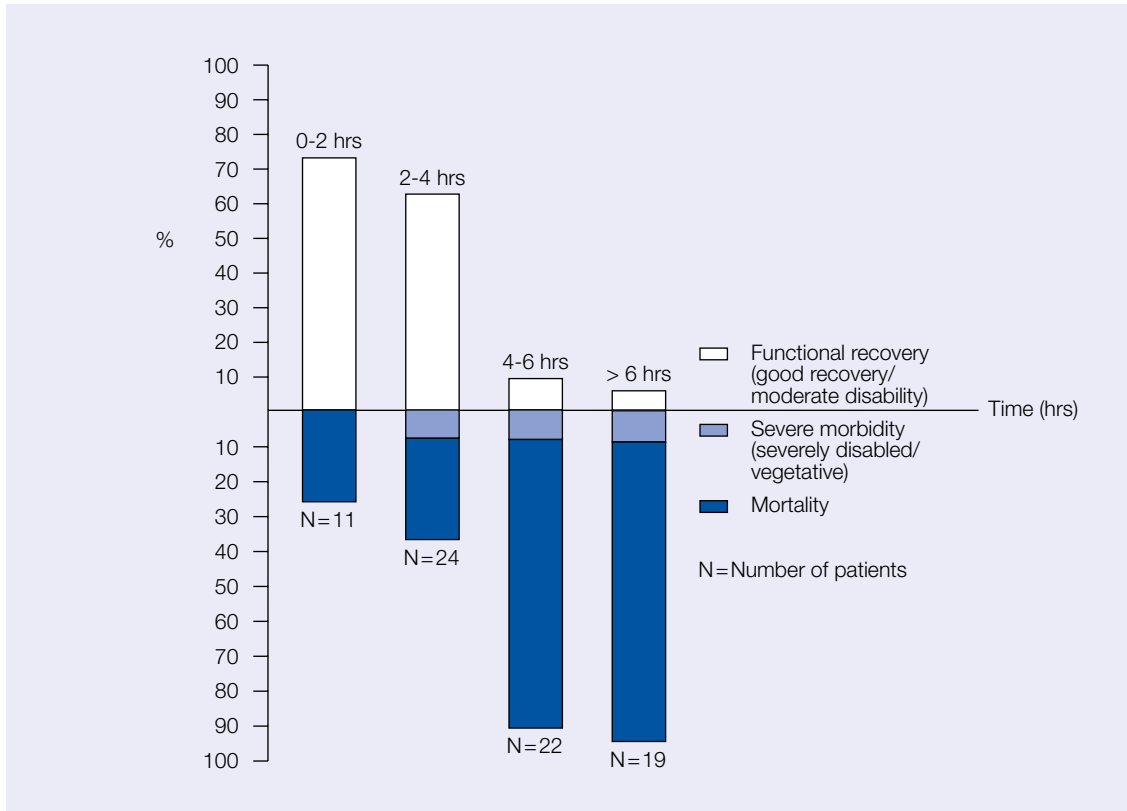

Fig. 4-10. Influence of time delay from injury to surgical intervention on outcome in 76 patients with acute subdural hematoma, from the work of Seelig et al. There was a significant increase in mortality rate when the delay exceeded 4 hours ($p < 0.0001$). The range of time delay in the group who underwent surgery >6 hours after injury was between 6.2 and 18.3 hours

Title

Adverse effects of prolonged hyperventilation in patients with severe head injury: a randomized clinical trial

Author

Muizelaar JP, Marmarou A, Ward JD, Kontos HA, Choi SC, Becker DP, Gruemer H, Young HF

Reference

J Neurosurg 1991; **75**: 731–739

Abstract

There is still controversy over whether or not patients should be hyperventilated after traumatic brain injury, and a randomized trial has never been conducted. The theoretical advantages of hyperventilation are cerebral vasoconstriction for intracranial pressure control, and reversal of brain and cerebrospinal fluid acidosis. Possible disadvantages include cerebral vasoconstriction to such an extent that cerebral ischemia ensues, and only a short-lived effect on cerebrospinal fluid pH with a loss of HCO_3^- buffer from cerebrospinal fluid. The latter disadvantage might be overcome by the addition of the buffer tromethamine, which has shown some promise in experimental and clinical use. Accordingly, a trial was performed with patients randomly assigned to receive normal ventilation (PaCO_2 35 ± 2 mmHg [mean \pm standard deviation]: control group), hyperventilation (PaCO_2 25 ± 2 mmHg: hyperventilation group), or hyperventilation plus tromethamine (PaCO_2 25 ± 2 mmHg: hyperventilation + tromethamine group). Stratification into subgroups of patients with motor scores of 1–3 and 4–5 took place. Outcome was assessed according to the Glasgow outcome scale at 3, 6, and 12 months. There were 41 patients in the control group, 36 in the hyperventilation group, and 36 in the hyperventilation + tromethamine group. The mean Glasgow coma scale score for each group was 5.7 ± 1.7 , 5.6 ± 1.7 , and 5.9 ± 1.7 , respectively; this score and other indicators of severity of injury were not significantly different. A 100% follow-up review was obtained. At 3 and 6 months after injury, the number of patients with a favorable outcome (good or moderately disabled) was significantly ($p < 0.05$) lower in the hyperventilated patients than in the control and hyperventilation + tromethamine groups. This occurred only in patients with a motor score of 4–5. At 12 months post-trauma, this difference was not significant ($p = 0.13$). Biochemical data indicated that hyperventilation could not sustain alkalinization in the cerebrospinal fluid, although tromethamine could. Accordingly, cerebral blood flow was lower in the hyperventilation + tromethamine group than in the control and hyperventilation groups, but neither cerebral blood flow nor arteriovenous difference of oxygen data indicated the occurrence of cerebral ischemia in any of the three groups. Although mean intracranial pressure could be kept well below 25 mmHg in all three groups, the course of intracranial pressure was most stable in the hyperventilation + tromethamine group. It is concluded that prophylactic hyperventilation is deleterious in head-injured patients with motor scores of 4–5. When sustained hyperventilation becomes necessary for intracranial pressure control, its deleterious effect may be overcome by the addition of tromethamine.

Summary

A total of 113 patients (age >3 years) with initial Glasgow coma scale score ≤ 8 were stratified by motor score (>3 or ≤ 3) and randomized to a control group, hyperventilation, or hyperventilation plus tromethamine. These treatment groups were chosen on the basis of the authors' experimental data in animals suggesting that sustained hyperventilation resulted in an increase in cerebrospinal fluid lactate that could be ameliorated by administration

of tromethamine. All patients were intubated, mechanically ventilated, and sedated with morphine. Intracranial pressure >25 mmHg was treated with paralysis, cerebrospinal fluid drainage, mannitol, and barbiturates, as needed. PaCO₂ was kept at 30–35 mmHg in controls and 24–28 mmHg in hyperventilation and hyperventilation plus tromethamine groups. Tromethamine was administered for arterial pH ≤7.6. Physiological variables, including cerebral blood flow, arteriovenous oxygen difference, cerebral metabolic rate of oxygen, and blood and cerebrospinal fluid pH and lactate were assessed. Neurological outcome was evaluated by Glasgow outcome scale scores at 3, 6, and 12 months. The study was terminated early because interim analysis revealed worse Glasgow outcome scale scores in the hyperventilation group at 3 and 6 months (Table 4-2). The only physiological variables that were significantly different were a reduction in cerebral blood flow in the tromethamine group, reductions in arteriovenous oxygen difference in control and hyperventilation groups, and a reduction in cerebral metabolic rate of oxygen in the control group. Cerebrospinal fluid alkalosis was maintained only in the tromethamine group. Administration of mannitol or barbiturates was similar between treatment groups. For patients with motor scores of 4–5, Glasgow outcome scale scores were worse in the hyperventilation group compared with both control and hyperventilation plus tromethamine groups at 3 and 6 months, but did not differ at 12 months after injury. Prophylactic sustained hyperventilation may be associated with delayed recovery from head injury in patients with initial motor scores of 4–5. When needed for intracranial pressure control, the deleterious effects of hyperventilation may be overcome by the addition of tromethamine.

Citation count 398

Related references

1. Bruce DA, Raphaely RC, Goldberg AI *et al*. Pathophysiology, treatment and outcome following severe head injury in children. *Childs Brain* 1979; **5**: 174–191.
2. Forbes ML, Clark RS, Dixon CE *et al*. Augmented neuronal death in CA3 hippocampus following hyperventilation early after controlled cortical impact. *J Neurosurg* 1998; **88**: 549–556.
3. Direnger MN, Yundt K, Videen TO *et al*. No reduction in cerebral metabolism as a result of early moderate hyperventilation following severe traumatic brain injury. *J Neurosurg* 2000; **92**: 7–13.

Key message

Prophylactic hyperventilation after traumatic brain injury may be associated with loss of bicarbonate buffer in cerebrospinal fluid, and delayed neurological recovery; however, the effects on outcome seen in this study are only transient, and outcome at 1 year did not differ between groups.

Why it's important

At the time this study was performed, hyperventilation to PaCO₂ of approximately 25–30 torr was standard care after severe head injury. Studies by the authors in laboratory animal models suggested that hyperventilation was associated with loss of cerebrospinal fluid bicarbonate buffer, and may be detrimental after traumatic brain injury. Additionally, a number of studies had demonstrated early low cerebral blood flow after severe traumatic brain injury, or reduced blood flow around contusion sites. Hyperventilation in these instances produced worrying local flow reductions. This study represented the key piece of clinical data supporting a tangible deleterious effect of hyperventilation on outcome after traumatic brain injury.

Strengths

1. This is a randomized, controlled, clinical trial.
2. This study builds on the authors' laboratory experiments, bringing the bench to the bedside.

Weaknesses

1. This study is not blinded.
2. An initial protocol violation resulted in patients being assigned to the control group without proper randomization, although this was corrected early in the study.
3. The transient nature of the deleterious effects of hyperventilation raises questions regarding the true clinical implications. Alternatively, this may just reflect insufficient power to detect a long-term effect.

Relevance

Based on the results of this study and others, prophylactic hyperventilation was largely abandoned in the standard management of severe head injury because of its potentially deleterious effects. In a recent animal study, Forbes *et al.* (2) showed that damage to the hippocampus, the most vulnerable region after traumatic brain injury, was exacerbated by aggressive hyperventilation early after injury. However, brief hyperventilation to treat refractory intracranial hypertension or impending herniation is still an important therapeutic tool. Similarly, sustained hyperventilation may be an important second tier treatment for refractory intracranial hypertension, when used with appropriate monitoring of cerebral blood flow and metabolism. Recent work by Diringer *et al.* (3), using positron emission tomography imaging techniques in patients after head injury, suggests that cerebral metabolic rate of oxygen is reduced after head injury such that hyperventilation applied 8–14 hours after injury does not contribute to ischemia, as assessed by changes in cerebral metabolic rates for oxygen. Future studies are thus needed to define the optimal application of hyperventilation after traumatic brain injury.

Table 4-2. Data from the work of Muizelaar et al. showing the putative detrimental effect of hyperventilation (HV) on 3-month and 6-month outcome after severe head injury. Addition of tromethamine (THAM) appeared to counteract the detrimental effect of HV. Outcome at 3, 6 and 12 months, stratified for motor scores 1–3 and 4–5 in the three treatment groups.*

Motor score	Group	Total cases	3 months			6 months			12 months		
			G/MD	SD/V	D	G/MD	SD/V	D	G/MD	SD/V	D
No. of cases	control	20	1	9	10	3	6	11	4	5	11
	HV	19	1	11	7	4	8	7	4	8	7
	HV 1 THAM	15	1	8	6	1	8	6	3	4	8
4–5	control	21	10	9	2	12	7	2	12	6	3
	HV	17	3†	13	1	4†	12	1	7	8	2
	HV 1 THAM	21	9	9	3	12	6	3	14	4	3
% of cases	control		5	45	50	15	30	55	20	25	55
	HV		5	58	37	21	42	37	21	42	37
	HV 1 THAM		7	53	40	7	53	40	20	27	53
	control		48	43	10	57	33	10	57	30	15
	HV		18†	77	6	24†	71	6	44	47	12
	HV 1 THAM		43	43	14	57	29	14	67	19	14

*Outcome assessed according to the Glasgow outcome scale: G = good, MD = moderate disability, SD = severe disability, V = vegetative state, D = death.

†Significantly different from control, $p < 0.05$, multiple logistic regression technique.

Title

Prevention of secondary ischemic insults after severe head injury

Author

Robertson CS, Valadka AB, Hannay HJ, Contant CF, Gopinath SP, Cormio M, Uzura M, Grossman RG

Reference

Crit Care Med 1999; **27**: 2086–2095

Abstract

Objective: The purpose of this study was to compare the effects of two acute-care management strategies on the frequency of jugular venous desaturation and refractory intracranial hypertension, and on long-term neurologic outcome in patients with severe head injury. **Design:** Randomized clinical trial. **Setting:** Level I trauma hospital. **Patients:** One hundred eighty-nine adults admitted in coma because of severe head injury. **Interventions:** Patients were assigned to either cerebral blood flow-targeted or intracranial pressure-targeted management protocols during randomly assigned time blocks. In the cerebral blood flow-targeted protocol, cerebral perfusion pressure was kept at > 70 mmHg, and PaCO₂ was kept at approximately 35 torr (4.67 kPa). In the intracranial pressure-targeted protocol, cerebral perfusion pressure was kept at > 50 mmHg, and hyperventilation to a PaCO₂ of 25–30 torr (3.33–4.00 kPa) was used to treat intracranial hypertension. **Measurements and Main Results:** The cerebral blood flow-targeted protocol reduced the frequency of jugular desaturation from 50.6% to 30% ($p = 0.006$). Even when the frequency of jugular desaturations was adjusted for all confounding factors that were significant, the risk of cerebral ischemia was 2.4-fold greater with the intracranial pressure-targeted protocol. Despite the reduction in secondary ischemic insults, there was no difference in neurologic outcome. Failure to alter long-term neurologic outcome was probably attributable to two major factors. A low jugular venous saturation was treated in both groups, minimizing the injury that occurred in the intracranial pressure-targeted group. The beneficial effects of the cerebral blood flow-targeted protocol may have been offset by a five-fold increase in the frequency of adult respiratory distress syndrome. **Conclusions:** Secondary ischemic insults caused by systemic factors after severe head injury can be prevented with a targeted management protocol. However, potential adverse effects of this management strategy may offset these beneficial effects.

Summary

Autoregulation of cerebral blood flow is commonly disturbed in patients with severe traumatic brain injury, and this increases susceptibility to secondary ischemic insults. One way to compensate for the disturbance in autoregulation is to raise cerebral perfusion pressure – maintaining it above a critical threshold for adequate cerebral blood flow. Supporting this concept, Gopinath et al. (1) reported that outcome was strongly associated with the number of jugular venous desaturation (.50%) episodes in patients with severe traumatic brain injury. The purpose of this study was to compare the effects of two acute management strategies – a cerebral blood flow-targeted approach (maintaining cerebral perfusion pressure .70 mmHg using fluids and pressors, and avoiding hyperventilation) versus an intracranial pressure-targeted approach (maintaining cerebral perfusion pressure .50 mmHg using fluids, pressors, and hyperventilation as needed) on the frequency of jugular venous desaturation (.50% for .10 minutes), refractory intracranial hypertension (intracranial pressure .25 mmHg), and long-term outcome after severe head injury (3- and 6-month Glasgow outcome scale). Using these two approaches in a randomized controlled trial in 189 adults, the authors demonstrated that the cerebral blood flow-targeted approach was

associated with higher cerebral blood flow, fewer jugular venous desaturation episodes, but greater pressor and fluid requirements. However, despite reducing the incidence of jugular venous desaturation episodes, no benefit on long-term outcome could be shown. Similarly, although cerebral blood flow promotion (targeting a cerebral perfusion pressure .70 mmHg) was not associated with either death from refractory intracranial hypertension or increased risk of intracranial hemorrhage, this strategy produced a five-fold increase in the incidence of adult respiratory distress syndrome compared with the intracranial pressure-targeted approach (cerebral perfusion pressure .50 mmHg). The authors suggested that the morbidity from the greater incidence of adult respiratory distress syndrome may have precluded any benefit of the cerebral blood flow-targeted strategy on long-term outcome.

Citation count 182

Related references

1. Gopinath SP, Robertson CS, Contant CF *et al.* Jugular venous desaturation and outcome after head injury. *J Neurol Neurosurg Psychiatry* 1994; **57**: 717–723.
2. Rosner MJ, Daughton S. Cerebral perfusion pressure management in head injury. *J Trauma* 1990; **30**: 933–941.
3. Ståhl N, Ungerstedt U, Nordström C-H. Brain energy metabolism during controlled reduction of cerebral perfusion pressure in severe head injuries. *Intensive Care Med* 2001; **27**: 1215–1223.

Key message

This paper has two key messages. First, an aggressive cerebral blood flow-promoting strategy can reduce the incidence of secondary ischemic episodes in the brain, as reflected by fewer jugular venous desaturation episodes. Second, systemic complications of cerebral perfusion pressure-directed therapies may produce important detrimental effects.

Why it's important

Despite its recent vintage, this is a classic study investigating the application of an aggressive brain-oriented therapeutic strategy in patients with severe traumatic brain injury. This work builds on the important, and frequently cited, study of Rosner and Daughton (2) that supported the importance of maintaining cerebral perfusion pressure. In addition, this study demonstrates, as well or better than any other to date in the field of clinical traumatic brain injury, the importance of a multidisciplinary approach to treatment. It is unlikely that such a high incidence of pulmonary complications (i.e. adult respiratory distress syndrome) would be predicted in targeting a cerebral perfusion pressure of 70 mmHg rather than 50 mmHg. This is a rare study where despite proving the primary hypothesis, the results may direct clinicians away from the management that achieved the treatment goal.

Strengths

1. Prospective design, state-of-the-art bedside clinical monitoring, careful control of confounders, and well-defined outcome parameters.
2. It is a model study for testing physiologically relevant neurointensive care interventions in critically ill patients with acute brain injury.

Weaknesses

1. The aggressive monitoring approach taken by this group, including monitoring and responding to jugular venous desaturations in both groups, may have made it difficult to demonstrate any beneficial effect. They may have compared aggressive with super-aggressive approaches.

- The average cerebral perfusion pressure in the flow-targeted group was nearly 80 mmHg, while it was >70 mmHg in the intracranial pressure-targeted group (Figure 4-11). Although these differed significantly, clearly it is misleading to suggest that cerebral perfusion pressure of 50 mmHg was the 'goal' in the intracranial pressure-targeted group.
- This group of investigators has a very aggressive approach to cerebral perfusion pressure management, and this fact must be taken into account when interpreting the results.

Relevance

Although this study demonstrates that some secondary ischemic episodes can be prevented in the intensive care unit with appropriate therapy, the authors themselves suggest that 'the approach of treating all patients by artificially maintaining cerebral perfusion pressure at an elevated level to compensate for the inability of the injured brain to autoregulate at more normal cerebral perfusion pressure levels may be too simplistic'. A better understanding of the mechanisms involved in both the impairment in blood flow autoregulation after trauma and the accompanying metabolic derangements is needed. Similarly, it may be critical to identify specific individuals in whom cerebral blood flow-targeted management might be indicated, and it may be important to titrate such therapies, rather than applying them to a single preselected target cerebral perfusion pressure (3). Novel strategies, other than simply increasing mean arterial blood pressure with fluids and pressors, may be needed to prevent secondary ischemic insults to the injured brain.

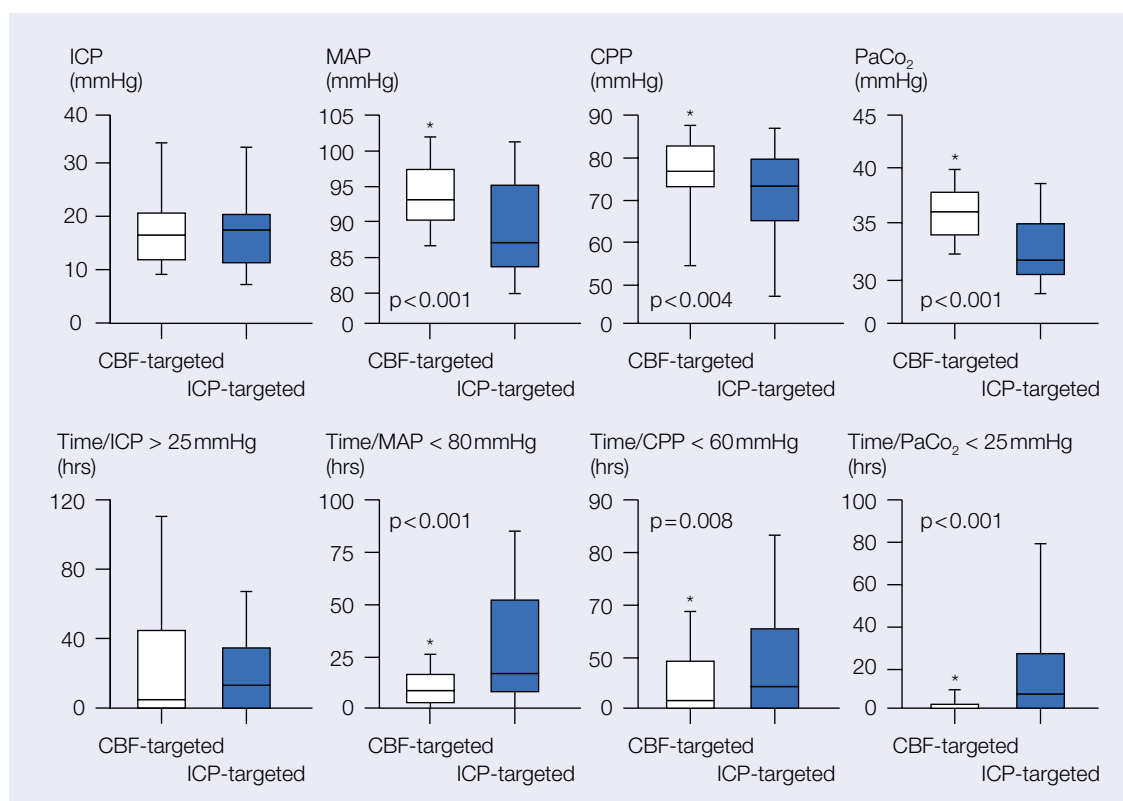

Fig. 4-11. Graphs of key physiological parameters in patients from the study of Robertson et al. examining strategies to prevent secondary ischemic insults after traumatic brain injury. Average mean arterial pressure (MAP), cerebral perfusion pressure (CPP) and PaCO₂, averaged for the entire monitoring period (top), were significantly higher in the cerebral blood flow (CBF)-targeted group (white bars) than in the intracranial pressure (ICP)-targeted group (grey bars). The number of hours that the MAP, CPP and end-tidal CO₂ (PetCO₂) were less than their respective critical values was less in the CBF-targeted group than in the ICP-targeted group (bottom)

The gut and its role in circulatory shock

Ulf H. Haglund MD PhD

Introduction

Our understanding of the underlying pathophysiological processes in the development of severe shock, multiple organ failure, and death following trauma, hemorrhage, and sepsis was quite vague around 1950, and is still not complete. World War II and the wars during the following decades, in Korea and Vietnam, stimulated much research aimed at achieving further knowledge in this area. A major part of this research was experimental, and based on large experimental animals such as dogs, pigs, and cats, and techniques commonly used in studies of normal physiology. During the 1930s and 1940s, the very basic principles of shock, such as the importance of hypovolemia following hemorrhage, became established. Moreover, around 1950, the importance of early fluid resuscitation was also recognized. At that time, however, it was not clear what disturbances took place in the peripheral circulation during shock, and to what extent, if any, these disturbances influenced the outcome. This chapter focuses on publications from 1950 and onwards which were of importance for our understanding of the role of the peripheral circulation during shock. I have included papers that focus on the splanchnic circulation, and those which explore mechanisms by which this particular area could exert an influence on the outcome of the shock state. The mechanisms discussed in these papers are still considered important in the pathophysiology of shock today. Most of the experimental papers discussed here study whole animal physiology and outcome of induced shock. The results and mechanisms discussed in these papers were verified in clinical studies, and it is this clinical correlation that makes the reported papers important and classical. One paper cited (Parrillo *et al.* 1985) is both clinical and experimental. It is included since it verified in patients a mechanism that was originally described in experimental studies, but that had become very controversial because of the lack of a clear clinical correlate.

Title

The intestinal factor in irreversible hemorrhagic shock

Author

Lillehei RC

Reference

Surgery 1957; **42**: 1043–1054

Abstract

Not available

Summary

Groups of anesthetised dogs (n = 10, 30 in each group) were subjected to hemorrhage down to a mean arterial blood pressure of 35 mmHg. The blood pressure was kept at this level for 5 hours. The animals were then retransfused with the shed blood. One group was left as a hemorrhage control, while the others had various parts of the body perfused by blood of normal pressure and oxygenation by means of cross-perfusion from a healthy donor dog during the 5-hour shock period. One of 15 animals in the hemorrhage control group survived >72 hours; most animals died within 9 hours. The groups perfused through the superior mesenteric artery, with withdrawal of an equal amount of blood from the caval vein, with or without a porto-caval shunt, did significantly better (9 out of 10, and 27 out of 30 survived, respectively). Similar perfusion through the inferior caval vein, the aorta, celiac axis, the portal vein, or a carotid artery was followed by a survival of 2–4 of 10 animals. At autopsy, hemorrhagic necrosis of the gut mucosa was seen in animals that died during the experiments, but not in sacrificed survivors.

Citation count

253

Related references

1. Wiggers CJ. *The Physiology of Shock*. New York: Commonwealth Fund, 1950.
2. Marston A. The bowel in shock. *Lancet* 1962; **2b**: 881.
3. Lillehei, RC, Longerbeam JK, Bloch JH, Manax WG. The nature of irreversible shock: experimental and clinical observations. *Ann Surg* 1964; **160**: 682–708.

Key message

The disturbances in the splanchnic circulation, and particularly the consequences of reduced perfusion pressure and impaired oxygen delivery to the gut, are of very significant importance for the outcome of circulatory shock.

Why it's important

At the time of this publication, there was still very little understanding of the pathophysiological process underlying the development of what was called irreversible hemorrhagic shock. Nor was it understood why shock became irreversible, and how to counteract this development. At this time, there was also much interest devoted to the issue of which

organ or organ system primarily failed during hypovolemia, and what were the consequences of such breakdown. Several authors have highlighted the splanchnic area as particularly important. This paper for the first time brought clear evidence indicating an important role of the gut early in the development of shock. It also pointed to an association between development of severe or irreversible shock and the mucosal necrosis of the gut, which was demonstrated in dying animals in this study. The observations published in this paper became a common background for further experimental and clinical studies on the pathophysiology of shock, and on monitoring and treatment of shock during the coming decades; to some extent, this paper still has this role, although it is not cited so often nowadays.

Strengths

The focused design of the study, including adequate controls and adequate number of independent observations.

Weaknesses

There was no effort to support the conclusions statistically, which was more or less customary at the time.

Relevance

The observation that changes in the gut blood flow during shock may be crucial for the further development of shock is still quite relevant. However, today a multi-factorial approach is necessary for a relevant interpretation of the results of this paper.

Title

The bacterial factor in traumatic shock

Author

Fine J, Frank ED, Ravin HA, Rutenberg SH, Schweinburg FB

Reference

N Engl J Med 1959; **260**: 214–220

Abstract

Not available

Summary

This publication summarizes a series of publications from this group of investigators indicating the appearance of a toxin in the blood of animals during hemorrhagic and traumatic shock. This toxin is bacterial (endotoxin), and causes irreversibility of shock (transferring hemorrhagic shock to septic), it is normally present in tissues, and is produced by Gram-negative bacteria, especially in the gastrointestinal tract. In shock, the reticulo-endothelial system neutralizes the effects of endotoxin normally present, but will become impaired depending on the intensity and duration of shock. These authors also demonstrated that reserpine or dienamine given prophylactically could improve survival in shock, and they accounted this effect to prevention of 'unresponsiveness to therapy' of peripheral blood vessels caused by excessive amounts of endotoxin.

Citation count

168

Related references

1. Kuida H. Discussion of 'the intestinal circulation in shock'. *Gastroenterology* 1967; **52**: 458–460.
2. Deitch E. Multiple organ failure. Pathophysiology and potential future therapy. *Ann Surg* 1992; **216**: 117–134.
3. Marshal JC, Christou NV, Meakins JL. The gastrointestinal tract. The 'undrained abscess' of multiple organ failure. *Ann Surg* 1993; **218**: 111–119.

Key message

In this paper, the authors strongly propose their view that shock becomes a lethal condition because of the appearance of endotoxin in blood. The main source of endotoxin is the gut. The authors also indicate the significant importance of the reticulo-endothelial system in shock conditions. Unfortunately, they suggested that this mechanism involving release of endotoxin to blood was the only route by which mortality was induced by, for example, hemorrhage or tissue trauma.

Why it's important

The importance of this report is the evidence that bacteria in the gut and the endotoxin they produce could cause further exacerbation of hemorrhagic or traumatic shock. The

indication that the function of the tissue-bound macrophages of the reticulo-endothelial system could influence outcome of shock is also very important. Bacteria and endotoxin are still considered as potentially important factors, and today this system is referred to as translocation. Macrophages and the cytokines that these and other cells release are identified as very important mediators in several critical processes of life, including the reactions to trauma and hemorrhage. Dr Fine and his group pointed out a very significant mechanism. The mistake they made was to over-interpret their results and over-estimate the clinical relevance of their experimental data. According to their paper, release of bacterial endotoxin was the only factor determining the outcome of shock. Other authors could easily demonstrate in control experiments – e.g. using so-called bacteria-free animals – that there are other ways of dying from bleeding than by bacterial translocation. In the debate that followed this and related reports, the scientific community tended to argue that if it is not always right, it is probably never right – an equally unfortunate conclusion.

Strengths

The demonstration of one mechanism still viewed as potentially very important in the development of severe shock.

Weaknesses

The over-estimation of the relevance of the experimental findings, and the lack of proper controls in this regard.

Relevance

The findings and the proposals based upon them are still relevant for our understanding of the pathophysiological processes in the development of severe shock.

Title

Effect of hemorrhagic shock on the reactivity of resistance and capacitance vessels and on capillary filtration transfer in cat skeletal muscle

Author

Mellander S, Lewis DH

Reference

Circ Res 1963; **13**: 105–118

Abstract

Not available

Summary

The reactions to sympathetic nerve stimulation of the series-coupled segments of the peripheral vasculature (resistance vessels, capillaries, and capacitance vessels) during hemorrhagic hypotension (40–50 mmHg) were studied in the skeletal muscle in experiments on anesthetized cats. Sympathetic nerve stimulation induced a powerful increase in the resistance to blood flow (constriction of arteriole) early during hypotension, an inward movement of fluid from tissue to blood across the capillary wall, and a significant reduction of regional blood volume (constriction of venules and veins). During the course of hemorrhagic hypotension, there is impairment and eventually abolition of both the resistance and the capacitance vessel response in the skeletal muscle. The reaction to intra-arterial infusion of noradrenaline was similar. The resistance vessel response faded away faster, and the time to abolition was faster than that of the capacitance vessels. This difference in response between the pre-capillary and the post-capillary vessels influenced the fluid movements across the capillary wall. The inward movement of fluid became less pronounced, and eventually sympathetic nerve stimulation caused losses of fluid. After retransfusion, the effects normalized.

Citation count 175

Related references

1. Lewis DH, Mellander S. Competitive effects of sympathetic control and tissue metabolites on resistance and capacitance vessels and capillary filtration in skeletal muscle. *Acta Physiol Scand* 1962; **56**: 162–188.
2. Lillehei RC, Longerbeam JK, Bloch JH, Manax WG. The nature of irreversible shock: experimental and clinical observations. *Ann Surg* 1964; **160**: 682–708.
3. Haglund U, Lundgren O. The effects of vasoconstrictor nerve stimulation on consecutive vascular sections of cat small intestine during hemorrhagic hypotension. *Acta Physiol Scand* 1973; **88**: 95–108.

Key message

This paper reports, for the first time, the reactions of the different functional segments of the peripheral vessels, and the effects of duration of hypotension on this effect. In the skeletal muscle, the increased resistance to blood flow upon sympathetic nerve stimulation rapidly became much less pronounced. Also, the mobilization of fluid from the tissue, as well as the mobilization of blood from the vascular bed (capacitance vessels), was dependent on the duration of hypotension. Late in the study period, sympathetic nerve stimulation caused very little if any mobilization of venous blood, and the inward filtration of fluid became reversed to a fluid loss to the tissue.

Why it's important

Until this report, the peripheral circulation has tended to be regarded as a unified entity with resistance to blood flow as the important variable. The different functional segments of the vasculature, the possibility of a differing response of the individual segments, and the influence of duration of hypotension on them were not appreciated before this report. The effect demonstrated in this report was used as the physiological basis for different strategies for the treatment of shock. The first, and perhaps most important, of such suggestions was the treatment of shock with large doses of corticosteroids. This report also highlighted the peripheral vascular bed as an important target in shock.

Strengths

Well planned and performed experiments using physiological techniques and skill to investigate pathophysiology of shock.

Weaknesses

The lack of quantitative data, and statistical treatment of data.

Relevance

The message included in this paper, and the different suggestions based upon it, had, and still have, an important influence on the clinical care of patients in shock.

Title

'Hidden acidosis' in experimental shock

Author

Bergentz SE, Carlsten A, Gelin L-E, Kreps J

Reference

Ann Surg 1969; **169**: 227–232

Abstract

Not available

Summary

Shock was induced by exteriorization of the small intestine for 2 hours. This caused hypotension, but only slight changes in acid-base balance in blood. After replacement of the gut, and fluid replacement with low molecular weight dextran or saline, blood pressure started to normalize. Arterial pH fell, and lactic acid and pyruvic acid increased initially but normalized after about 1 hour. The acidosis of the peripheral tissues was not reflected in the blood due to impaired tissue perfusion during shock. It was also concluded that dextran infusion in particular improved tissue perfusion. The discrepancy between tissue and blood was referred to as 'hidden acidosis'.

Citation count

41

Related references

1. Hardaway RM. The problem of acute severe trauma and shock. *Surg Gynecol Obstet* 1971; **133**: 799–806.
2. Schlichtig R, Bowles SA. Distinguishing between aerobic and anaerobic appearance of dissolved CO₂ in intestine during low flow. *J Appl Physiol* 1994; **76**: 2443–2451.
3. Consensus Report. Tissue hypoxia. How to detect, how to correct, how to prevent. *Intensive Care Med* 1996; **22**: 1250–1257.

Key message

Blood variables do not necessarily reflect the true condition in the tissues during acute and critical disease. This is especially important to keep in mind in acute conditions characterized by impaired peripheral blood circulation. Whether infusion of dextran solutions has effects superior to those obtained by starch or other infusates or not remains to be demonstrated.

Why it's important

The important changes in critical illness take place in the peripheral tissues. These changes are very difficult to monitor clinically. It is therefore very important for the clinician to realize the possibility of 'hidden' changes in various acute conditions. This knowledge had not been supported by data and was not generally appreciated before this report.

Strengths

The report on the discrepancy between blood variables and true tissue conditions.

Weaknesses

The low number of independent observations, and the lack of statistical support in the effort to compare different infusion fluids.

Relevance

The basic knowledge from this report, the possibility of 'hidden' changes in the tissue, is still very relevant for clinicians treating patients in shock.

Title

Intestinal mucosal lesion in low-flow states. A morphological, hemodynamic, and metabolic reappraisal

Author

Chiu C-J, McArdle AH, Brown R, Scott HJ, Gurd FN

Reference

Arch Surg 1970; **101**: 478–483

Abstract

Not available

Summary

In experiments on dogs, using a pump technique for perfusion of the superior mesenteric artery – and stopping blood flow in this artery by means of a clamp – it was demonstrated that microscopic mucosal injury developed depending on the degree and duration of blood flow restriction. It was also demonstrated that the injury developed sequentially, and the different recognized steps in this sequence of events could be used in a grading system. Microscopic evidence was presented for an initial phase of injury characterized by subnuclear portion and subsequent lifting of the epithelial layer. The suggested grading system for mucosal injury of the small intestine is based on six different grades. Grade 1 is characterized by the development of a Gruenhagen's space at the top of the villi, in grade 2, this space is more extended and epithelial lifting is initiated. In grade 3, there is massive lifting, and in grade 4, loss of epithelial cells has started. In grade 5, the villi are denuded, and in grade 6, the villous layer is destroyed. Also, in advanced grade 6 injury, the crypt layer and the muscular layer are intact.

Citation count

575

Related references

1. Haglund U, Lundgren O. Non-occlusive acute intestinal vascular failure. *Br J Surg* 1979; **66**: 155–158.
2. Bounous G. Acute necrosis of the intestinal mucosa. *Gastroenterology* 1982; **82**: 1457–1467.
3. Park PO, Haglund U, Bulkley GB, Fält K. The sequence of development of intestinal tissue injury after strangulation ischemia and reperfusion. *Surgery* 1990; **107**: 575–580.

Key message

The most important result of this paper is the proposed grading system. It has been utilized in a vast number of studies in the following decades. The demonstration of a clear relationship between the degree of blood flow restriction and its duration on one hand, and the degree of tissue injury on the other has validated this grading system and made it particularly useful.

Why it's important

This paper provides two important messages. First, it demonstrates clearly that the development of the mucosal injury seen following periods of hypotension and shock is dependent on the degree and duration of impairment of intestinal blood flow. This finding implies that the reduction in oxygen delivery, which leads to tissue hypoxia despite compensatory mechanisms, is likely to be the pathophysiological mechanism. Second, this report provides a grading system based and validated on pathophysiology. A validated grading system is necessary for comparing the results in different studies, and for further progress in studies, of pathophysiology, as well as consequences of mucosal injury of the intestine in shock.

Strengths

Focused planning of experiments with the goal of achieving a validated grading system.

Weaknesses

A limited number of observations, and lack of statistical support.

Relevance

The results of this study are highly relevant for the understanding of the process leading to intestinal mucosal injury during shock. It was also highly relevant for the design of the experimental studies that followed during the subsequent 30 years in this field of research.

Title

Hyperosmotic NaCl and severe hemorrhagic shock

Author

Velasco IT, Pontieri V, Rocha e Silva M Jr, Lopes OU

Reference

Am J Physiol 1980; **239**: H664–H77

Abstract

Intravenous infusions of highly concentrated NaCl (2,400 mosmol/l; infused volume 4 ml/kg; equivalent to 10% of shed blood), given to lightly anesthetized dogs in severe hemorrhagic shock, rapidly restore blood pressure and acid-base equilibrium toward normality. No appreciable plasma volume expansion occurs for at least 12 hour, indicating that fluid shift into the vascular bed plays no essential role in this response. Initial effects were sustained indefinitely; long term survival was 100%, compared to 0% for a similar group of controls treated with saline. Hemodynamic analysis of the effects of hyperosmotic NaCl showed that these infusions substantially increase mean and pulse arterial pressure, cardiac output, and mesenteric flow, whereas heart rate was slightly diminished. These effects immediately follow infusions, with no tendency to dissipate with time (6-hour observation). We conclude that hyperosmotic NaCl infusions increase the dynamic efficiency of the circulatory system, enabling it to adequately handle oxygen supply and metabolite clearance, despite a critical reduction of blood volume.

Summary

Dogs were subjected to severe hemorrhage by bleeding over 15 minutes to a mean arterial blood pressure of 40 mmHg. This blood pressure level was then maintained for 30 minutes by further small volume bleeding. It was then demonstrated that resuscitation with 10% of bled volume was followed by 100% survival if the resuscitation fluid was hyperosmolar (2400 mosmol/L) saline, but no survival if ordinary saline was used. Plasma expansion did not account for this effect, but arterial blood pressure was restored, as were cardiac output and mesenteric blood flow. Arterial pH also normalized during the first few hours. Arterial base excess, which became negative during the hemorrhage period, tended to normalize as well. Hematocrit remained slightly below 30% in animals resuscitated with hyperosmolar saline. In animals resuscitated with ordinary saline blood pressure, blood flow and acid-base balance deteriorated rapidly. These changes were evident for a 6-hour period. Animals subjected to survival analysis were allowed water ad lib 12 hours after hemorrhage and were fed 24 hours later. They were then followed for 2 weeks.

In another series of experiments, it was demonstrated that hyperosmolar saline given to non-shocked animals had no effect on blood pressure, but increased cardiac output and pulse rate. Plasma osmolality was increased by 5–10% during the first 4 hours after resuscitation.

Citation count

352

Related references

1. Younes RN, Aun F, Accioly CQ *et al.* Hypertonic solutions in the treatment of hypovolemic shock: a prospective, randomized study in patients admitted to the emergency room. *Surgery* 1992; **111**: 380–385.
2. Wade CE, Kramer GC, Grady JJ *et al.* Efficacy of hypertonic 7.5% saline and 6% Dextran-70 in treating trauma: a meta-analysis of controlled clinical studies. *Surgery* 1997; **122**: 609–616.
3. Angle N, Hoyt DB, Coimbra R *et al.* Hypertonic saline resuscitation diminishes lung injury by suppressing neutrophil activation after hemorrhagic shock. *Shock* 1998; **9**: 164–170.

Key message

This paper demonstrated for the first time that rapid intravenous infusion of a small volume of hyperosmotic saline was not harmful and could be used successfully for primary resuscitation in hypovolemia. The effect achieved by hyperosmolar saline resuscitation was not achieved at the expense of the peripheral circulation. On the contrary, an improved peripheral circulation was demonstrated by increased blood flow in the superior mesenteric artery, and the lack of accumulation of acid metabolites demonstrated by the normalized arterial pH and base excess values.

Why it's important

This report opened the possibility of effective pre-hospital care of hemorrhage and hypovolemia. For practical reasons, such a treatment option has been lacking in many instances. This new principle of hyperosmotic fluid therapy offered such a possibility at low cost. For pre-hospital use, the small volume required is important, as it means that the resuscitation fluid is easy to carry. In experiments performed some years later, it was demonstrated that if hyperoncotic fluids were added and combined with the hyperosmotic saline, even better effects (longer duration) could be obtained.

Strengths

The original idea combined with an experimental set-up to make it possible to clearly demonstrate the potential possibilities of this treatment modality.

Weaknesses

Experimental studies on treatment of shock have certain limitations, mainly because of difficulties in simulating clinical reality with experimental models; however, the authors were fully aware of this. In later experiments, uncontrolled hemorrhagic models were used, in these, the duration of the effects obtained was much shorter.

Relevance

By indicating the possibility of a new principle for early resuscitation, this paper has a very high relevance. Clinical trials have revealed reduced mortality in trauma patients following resuscitation with hyperosmolar saline combined with hyperoncotic dextran.

Title

Superoxide radicals in feline intestinal ischemia

Author

Granger DN, Rutili G, McCord JM

Reference

Gastroenterology 1981; **81**: 22–29

Abstract

One hour of regional ischemia significantly increases the permeability of intestinal capillaries. The role of local humoral agents in the genesis of an increased capillary permeability in the ischemic bowel was assessed using specific antagonists to substances commonly believed to be involved in the pathogenesis of ischemic states. Capillary permeability estimates in autoperfused segments of cat ileum were derived from the relationship between lymph-to-plasma protein concentration ratio and lymph flow. Pretreatment of the ileal segments with either benadryl + cimetidine, indomethacin, or methylprednisolone did not significantly alter the permeability increase induced by regional ischemia. Pretreatment with superoxide dismutase (SOD), a superoxide radical scavenging enzyme, significantly attenuated the capillary permeability change induced by regional ischemia. Intravenous *E. coli* endotoxin administration in normotensive preparations increased intestinal capillary permeability; however, lethal doses of the endotoxin were required. The results of this study indicate that superoxide radicals are primarily responsible for the increased capillary permeability in the ischemic bowel.

Summary

In experiments in cats, the inflow arterial blood pressure to the small intestine was controlled at about 40 mmHg for 1 hour while intestinal lymph and venous outflow were monitored. The capillary permeability was reflected by the calculated osmotic reflection coefficient for total plasma protein. This was obtained using the steady-state relationship between the lymph/plasma protein concentration ratio and lymph flow in the post-occlusion period. One hour of regional ischemia significantly increased intestinal capillary permeability. Agents such as histamine 1 + 2 antagonists, indomethacin, or methylprednisolone had no significant effect on this permeability increase. On the other hand, superoxide dismutase (SOD), a superoxide radical scavenger, significantly attenuated the capillary permeability increase induced by ischemia. It was proposed that at reperfusion, oxygen radicals were generated due to accumulation of hypoxanthine and conversion of xanthine dehydrogenase to xanthine oxygenase, a proteolytic process initiated during ischemia. At reperfusion, when oxygen again becomes available, hypoxanthine is metabolized further. In this period, the further metabolism of hypoxanthine to xanthine and uric acid is catalyzed by xanthine oxidase, and so this process generates oxygen free radicals. They in turn are highly toxic and cause tissue injury.

Citation count 1081

Related references

1. Haglund U, Bulkley G, Granger DN. On the pathophysiology of intestinal ischaemic injury. *Acta Chir Scand* 1987; **153**: 321–324.
2. Hoshino T, Maley WR, Bulkley GB, Williams GM. Ablation of free radical-mediated reperfusion injury for the salvage of kidneys taken from non-heartbeating donors. *Transplantation* 1988; **45**: 284–289.
3. Granger DN. Role of xanthine oxidase and granulocytes in ischaemia-reperfusion injury. *Am J Physiol* 1988; **255** (*Heart Circ Physiol* **24**): H1269–H275.

Key message

Ischemia may cause tissue injury mainly by impaired perfusion causing impaired transportation of oxygen to the tissue, or possibly also by impaired transportation of toxic metabolites from the tissue. This report indicated for the first time that injury may also take place after ischemia – at reperfusion – due to the generation of oxygen free radicals. The authors also suggested the mechanism for the increased generation of oxygen free radicals at reperfusion – a mechanism that is still valid to a great extent.

Why it's important

It has long been known that tissue injury takes place during ischemia, and the development of strategies to delay or prevent this development has long been highly prioritized. With this report, a new field of research was opened: the reperfusion injury. It became evident that the insult was not ischaemia alone, nor reperfusion alone, but the combination – ischemia-reperfusion. The relationship between the two was later shown to vary from one tissue to another and from one pathophysiological situation to another. We now know that the so-called window of reperfusion injury may be quite narrow in certain situations. In clinical shock as well as following regional ischemia, the risk of a reperfusion injury is not a reason for delaying reperfusion. The use of reperfusion fluids containing scavenging components has been suggested, and such solutions are routinely used for organ preservation in organ transplantation. The importance of this report was that it initiated the research area of ischemia-reperfusion injury.

Strengths

The originality of the experimental approach based on the combined knowledge of physiology and free radical chemistry among the authors.

Weaknesses

This report does not have a significant weakness. One could ask for further data describing other situations, but it was reasonable to provide such data in subsequent publications.

Relevance

The report of a reperfusion component of tissue injury, in addition to an ischemic component, still has a very high relevance for our understanding of pathophysiological processes.

Title

Adequacy of tissue oxygenation in intact dog intestine

Author

Grum CM, Fiddian-Green RG, Pittenger GL, Grant BJB, Rothman ED, Dantzker DR

Reference

J Appl Physiol 1984; **56**: 1065–1069

Abstract

Changes in O₂ consumption, O₂ extraction, and intramural pH, resulting from a decreasing O₂ delivery, were studied in the intact dog intestine. The O₂ delivery was decreased by ischemia, hypoxia, and combined hypoxia-ischemia. A noninvasive approach for determining intramural pH based on the principle of tonometry was used. There was a strong correlation between the changes in intramural pH and intestinal O₂ consumption as O₂ delivery was decreased. Intramural pH and O₂ consumption were initially maintained in the face of decreasing O₂ delivery, but after a critical point they decreased. This critical point was 60.3 +/- 1.6% of baseline O₂ delivery in the ischemic group, and 51.3 +/- 2.7% of baseline in the hypoxic-ischemic group. Despite a decrease to 36.0 +/- 5.6% of baseline O₂ delivery, the intramural pH and O₂ consumption did not decrease in the hypoxic group. O₂ extraction increased with decreasing O₂ delivery but did not plateau, indicating no diffusion limitation. The data suggest that blood flow is the major factor limiting intestinal O₂ consumption. It is concluded that the noninvasive measure of intramural pH is a good marker of the adequacy of tissue oxygenation in canine intestine.

Summary

Changes in oxygen consumption, oxygen extraction, and intramural pH were studied in the intact dog intestine during decreasing oxygen delivery. Decreased oxygen delivery was caused by ischemia induced by a screw clamp on the superior mesenteric artery, by hypoxia caused by reduced oxygen in inspired air, and by a combination of the two. A non-invasive technique for determining intramucosal pH based on the principle of tonometry was described. The experimentally demonstrated equilibrium of pCO₂ between the superficial part of the mucosa and the fluid content of the lumen constitutes one prerequisite for this method. Another important assumption is that arterial bicarbonate reflects tissue bicarbonate. With these prerequisite, tissue pH could be calculated by the Henderson-Hasselbalch equation. There was a strong correlation between the changes in intramucosal pH and oxygen consumption as oxygen delivery was reduced. Intramural pH and oxygen consumption were initially maintained at the normal range when oxygen delivery was reduced, but they decreased when delivery was reduced below a critical point. It was concluded that the non-invasive method of determining intramural pH was a good technique for monitoring tissue oxygenation.

Citation count 244

Related references

1. Doglio D, Pusajo J, Egurrola M *et al.* Gastric mucosal pH as a prognostic index of mortality in critically ill patients. *Crit Care Med* 1991; **19**: 1037–1040.

2. Hartman M, Montgomery A, Jönsson K *et al.* Tissue oxygenation in hemorrhagic shock measured as transcutaneous oxygen tension, subcutaneous oxygen tension, and gastrointestinal intramucosal pH in pigs. *Crit Care Med* 1991; **19**: 205–210.
3. Gutierrez G, Palizas F, Doglio G *et al.* Gastric intramucosal pH as a therapeutic index of tissue oxygenation in critically ill patients. *Lancet* 1992; **339**: 195–199.

Key message

Tissue oxygenation could be monitored by a non-invasive technique based on tonometry. With this technique, it could be demonstrated that oxygenation remains adequate until oxygen delivery has been reduced below a certain point. With further reductions in delivery, oxygen consumption becomes flow delivery-dependent.

Why it's important

Crucial changes take place in the peripheral tissues during critical illness, and overwhelming amounts of data suggest that changes in the gastrointestinal tract may occur at a very early stage, and may cause further tissue injury. The non-invasive technique described and validated experimentally in this report provides a way of monitoring changes in the gut. This was the first time that a non-invasive technique for monitoring the intestines had been described. Further development of this technique has made it easier to handle and provided possibilities for instant bedside measurements. Others have demonstrated that gut intramucosal pH predicts mortality in critically ill patients, but treatment options making this knowledge useful in clinical practice have not yet been developed. The experimentally based hypotheses could be tested by this technique, as could the value of clinical monitoring of peripheral (splanchnic) oxygenation.

Strengths

The original idea that the principle of tonometry could be used as a means of non-invasive monitoring of tissue oxygenation. The experimental set-up was designed for this specific purpose.

Weaknesses

No data were presented that validated the basic prerequisites for the tonometric technique to determine tissue pH. Could arterial bicarbonate and the Henderson-Hasselbalch equation be used in pathophysiological conditions, and are there limitations to this use?

Relevance

The tonometric technique for monitoring splanchnic tissue oxygenation has been modified, but the basic idea remains highly relevant. In the modified technique, tonometry is still used to measure luminal $p\text{CO}_2$ in order to measure $p\text{CO}_2$ of the superficial mucosa. However, there is no need to calculate pH. Instead, the differences between mucosal $p\text{CO}_2$ and end tidal CO_2 could be measured in a rapid bedside process.

Title

A circulating myocardial depressant substance in humans with septic shock: septic shock patients with a reduced ejection fraction have a circulating factor that depresses in vitro myocardial cell performance

Author

Parrillo JE, Burch C, Shelhamer JH, Parker MM, Natanson C, Schuette W

Reference

J Clin Invest 1985; **76**: 1539–1553

Abstract

We have previously described a subpopulation of patients with septic shock who had a reversible depression of radionuclide-determined left ventricular ejection fraction (EF). To investigate the mechanism of this myocardial depression, an in vitro model of mammalian myocardial cell performance was established employing primary spontaneously beating rat myocardial cells. The contraction of a single cardiac cell was quantitated by recording the changes in area occupied by the cell during contraction and relaxation. In 20 septic shock patients during the acute phase, the mean left ventricular EF was decreased (mean = 0.33, normal mean = 0.50), and serum obtained during this acute phase induced a mean (+/- standard error of the mean) 33 +/- 4% decrease in extent, and 25 +/- 4% decrease in velocity of myocardial cell shortening during contraction ($P < 0.001$). In contrast, serum obtained from 11 of these same patients before shock ($n = 2$), or after recovery ($n = 9$) of the left ventricular EF (mean = 0.50), showed a return toward normal in extent and velocity of shortening ($P < 0.001$). Sera from 17 critically ill nonseptic patients, from 10 patients with structural heart disease as a cause for a depressed EF, and from 12 healthy laboratory personnel, induced no significant changes in in vitro myocardial cell performance. In 20 patients during the acute phase of septic shock, the decreased EF in vivo demonstrated a significant correlation ($r = +0.52$, $P < 0.01$) with a decrease in the extent of myocardial cell shortening in vitro. The quantitative and temporal correlation between the decreased left ventricular EF and this serum myocardial depressant substance argues for a pathophysiologic role for this depressant substance in producing the reversible cardiomyopathy seen during septic shock in humans.

Summary

The in vitro contraction of a single cultured spontaneously beating rat myocardial cell could be quantified by recording the changes in area occupied by the cell during contraction and relaxation. Using this technique, the authors measured the effect on myocardial cell performance of serum obtained from 20 septic patients in an acute phase of septic shock. As previously demonstrated, patients in septic shock may have a reduced left ventricular ejection fraction. Fourteen of the 20 patients studied survived their septic shock. At the time of serum sampling, the patients included in this study had a reduced cardiac ejection fraction (mean = 0.33, normal mean = 0.55). The serum of these septic patients reduced the extent of contractility. This effect was not present before septic shock or after recovery. The extent as well as the velocity of the contraction of the myocardial cells remained normal when serum obtained in these circumstances was introduced to the in vitro system. Serum from critically ill but not septic patients, from patients with structural heart disease with reduced ejection fraction, and from healthy laboratory personnel had no significant effect on in vitro myocardial cell performance. A significant correlation between the decreased ejection fraction in vivo and the effect of serum on myocardial

cells in vitro was demonstrated among the 20 patients in the acute phase of septic shock. It was concluded by the authors that the quantitative and temporal correlation between the decreased left ventricular ejection fraction and the serum myocardial depressant substance argues strongly for a pathophysiological role for this depressant substance in producing the cardiomyopathy seen during septic shock in patients.

Citation count 293

Related references

1. Lefer AM. Role of myocardial depressant factor in the pathogenesis of circulatory shock. *Fed Proc* 1970; **29**: 1836–1847.
2. Haglund U, Lundgren O. Cardiovascular effects of blood borne material released from the cat small intestine during simulated shock conditions. *Acta Physiol Scand* 1973; **89**: 558–570.
3. Carli AM, Auclair MC, Vernimmen C, Jourdon P. Reversal by calcium of rat heart cell dysfunction induced by human sera in septic shock. *Circ Shock* 1979; (Suppl) **6**: 147–157.

Key message

This report clearly provides evidence for the existence of a myocardial depressant substance in serum obtained from patients with septic shock and depressed left ventricular ejection fraction, but not in other critically ill patients, patients with depressed ejection fraction because of structural heart disease, or normal healthy people.

Why it's important

Since the early 1960s, it has been a matter of controversy as to whether depression of cardiac function occurred in shock, and, if so, whether it was a late factor, or a factor that occurred early and contributed to the further development of severe shock and multiple organ failure. A lot of experimental evidence, which suggested the early development of a myocardial depressant substance detectable in blood, became available also, work demonstrating that serum or plasma from patients contained such substances. The majority of these publications supported the concept that the site of origin of myocardial depressant substances was the pancreas and/or the intestines. However, the scientific community could not agree, and clinicians treating patients in shock were not convinced that this could be an important pathophysiological possibility. With this paper, Parrillo and co-workers further demonstrated that a significantly depressed myocardial function does occur frequently in patients with septic shock, and at the time of this functional myocardial depression, these patients have a substance in their serum that impairs myocardial cell function. Thereby, the controversy as to whether this effect does actually exist in septic shock patients was solved. In this series of patients, 30% of patients with serum containing myocardial depressant substances did not survive their septic shock. It still remains to be demonstrated to what extent the appearance of myocardial depressant substances in blood contributes to the poor outcome of septic shock. It also remains to be determined whether patients with shock of other genesis than sepsis also have myocardial depressant factors in their serum. Available experimental data support the concept that this could be the case.

Strengths

The design of the study, with myocardial cells in vitro as a bio-assay for myocardial depressant factors, and the demonstration that the septic shock patients at the time of inclusion had impaired left ventricular ejection fraction, make this study strong. Adequate control groups in adequate numbers further add to the strength.

Weaknesses

This study does not try to identify the biochemical nature of the myocardial depressant substance. It does not try to explain to the readers whether they are dealing with one or several depressant substances, nor do the authors try to identify the origin of this substance.

Relevance

Since the presence of myocardial depressant substances in blood has a significant influence on our understanding of the pathophysiology of shock, and therefore of treatment of shock, this paper remains highly relevant.

Title

Increased intestinal permeability in endotoxic pigs: mesenteric hypoperfusion as an etiologic factor

Author

Fink MP, Antonsson JB, Wang H, Rotschild HR

Reference

Arch Surg 1991; **126**: 211–218

Abstract

Infusing pigs with lipopolysaccharide (LPS) decreases superior mesenteric artery blood flow (Q_{sm}), suggesting that mesenteric hypoperfusion may be responsible for LPS-induced alterations in gut mucosal permeability. To test this hypothesis, we studied four groups of anesthetized swine. Group 1 animals (N = 6) were infused with LPS (250 micrograms/kg over 1 hour beginning at 60 minutes), and continuously resuscitated with Ringer's lactate (48 mL/kg per hour). In group 2 (N = 5), Q_{sm} was decreased by 50% by means of a mechanical occluder to mimic the LPS-induced alterations in Q_{sm} observed in group 1. Group 3 (N = 5) was included to document our ability to detect ischemia/reperfusion-induced alterations in mucosal permeability; in these pigs, Q_{sm} was decreased in steps to zero flow (at 150 to 210 minutes), and then perfusion was restored (at 210 to 270 minutes). Pigs in group 4 (N = 6) served as normal controls; these animals were resuscitated with Ringer's lactate at the same rate as in group 1, but were not infused with LPS. To assess mucosal permeability, we measured plasma-to-lumen clearances for two markers, chromium 51-labeled edetic acid monohydrate (EDTA), and urea. Loading and maintenance infusions of the markers were given intravenously, and a 20-cm isolated segment of small intestine was continuously perfused at 2 mL/min with Ringer's lactate at 37 degrees C. Results were expressed as the ratio of the clearances for the two probes (CEDTA/CUREA). In group 3, CEDTA/CUREA was 999% +/- 355% of baseline at 270 minutes. In group 1, CEDTA/CUREA was 572% +/- 235% of baseline at 270 minutes. In groups 2 and 4, however, CEDTA/CUREA did not change significantly from the baseline value over the duration of the study. These data suggest that increased mucosal permeability after LPS is due to factors other than (or in addition to) mesenteric hypoperfusion.

Summary

This series of experiments was performed on young pigs. Intestinal mucosal permeability was measured as the ratio of plasma-to-lumen clearances of Cr⁵¹ EDTA and urea. One group of the experimental animals was subjected to infusion of lipopolysaccharide (LPS, endotoxin) in an amount that caused hypotension and approximately 50% reduction of blood flow in the superior mesenteric artery. Another group had blood flow in this artery reduced to 50% by a mechanical occluder. A third group had stepwise reductions of superior mesenteric blood flow down to zero followed by reperfusion, and another group served as sham controls. It was demonstrated in comparisons between the two groups with a 50% reduction of superior mesenteric artery blood flow that the series subjected to LPS infusion had an increased permeability of the intestinal mucosa. While both groups of animals had an equal reduction of intestinal oxygen delivery, the group receiving LPS infusion had a maintained increased oxygen consumption in the intestine, while animals with a mechanical occluder on the artery had a reduction. Despite this, a mucosal acidosis was evident in the LPS group only. The conclusion is that increased permeability during endotoxin shock is due to other factors, or factors in addition to mesenteric hypoperfusion.

Citation count 131

Related references

1. Dahn M, Lange P, Lobdell K *et al.* Splanchnic and total body oxygen consumption differences in septic and injured patients. *Surgery* 1987; **101**: 69–80.
2. Van der Meer TJ, Wang H, Fink MP. Endotoxemia causes ileal mucosal acidosis in the absence of mucosal hypoxia in a normodynamic porcine model of septic shock. *Crit Care Med* 1995; **23**: 1217–1226.
3. Antonsson JB, Haglund UH. Gut intramucosal pH and intraluminal pO₂ in a porcine model of peritonitis and hemorrhage. *Gut* 1995; **37**: 791–797.

Key message

Impaired intestinal blood flow and reduced oxygen consumption in the gut are not the primary causes of intestinal mucosal injury in sepsis. Other, or additional, mechanisms are necessary as well. The general rules of physiology do not seem to apply to sepsis.

Why it's important

The understanding of the septic state has been more difficult than understanding the pathophysiology of hemorrhagic shock. The most likely explanation for this increased difficulty is that the general rules of physiology do not apply in sepsis. Every effort to understand sepsis is fruitless if it is based on knowledge of normal physiology only. Adequate blood flow does not necessarily mean adequate tissue oxygenation in sepsis, and adequate tissue pO₂ in sepsis does not necessarily mean that the cells can extract and utilize the oxygen that is there. This type of normoxic or cytopathic hypoxia is a very important characteristic of sepsis and septic shock. The difficulties we have had in understanding and appreciating this difference between sepsis and normal physiology probably explain why septic shock is still so frequently followed by multiple organ failure. Similarly, this is probably an important reason why septic shock still has a high mortality rate, and why sepsis is the most frequent cause of surgical intensive care treatment. This paper was among the first to highlight the difference with regard to cause and effect between endotoxemia/sepsis and reduced blood flow simulating hemorrhage.

Strengths

The design of these experiments focused on the possibility of demonstrating the discrepancy between endotoxemia and reduced mesenteric blood flow per se.

Weaknesses

As is often the case, additional variables such as tissue oxygen tension and other signs of intestinal mucosal injury could have been included.

Relevance

The main findings of this paper are still very relevant. The knowledge that has developed from this and related papers – indicating that the pathophysiology of sepsis, and especially tissue oxygenation in sepsis, differs very significantly from what we see in hypovolemic shock – is still valid and constitutes one of the more important pieces of information available when we have to select monitoring and treatment goals in critically ill septic patients.

Renal support

Mark G.A. Palazzo

Introduction

The choice of papers for this collection of classical works is not based on the first description of a subject, but has been directed toward their observations or studies that have either changed clinicians' thinking or management. These are recent, but there were significant advances in previous centuries, by the ingenious as well as the observant. This introduction provides an abbreviated history, which acknowledges and honors their contributions. (See also the Appendix at the end of the chapter.)

Historical background

Hippocrates of Cos, the Asclepiad (460–375 BC) in his treatise entitled *Aphorisms*, describes many aspects of renal function, including the association between proteinuria and chronic renal disease. This text, a series of treatise, from his school, written over several centuries, could be considered the first multi-author medical reference book.

Anatomy

Bartolomeo Eustachi (1520–1574) published the anatomy of the kidney in *Opuscula Anatomica* in 1564.

In 1662, Bellini (1643–1704) described the gross anatomy of the kidney, identified the renal excretory ducts ('Bellini's ducts'), and advanced a physical theory of the secretion of the urine.

Marcello Malpighi (1628–1694) described the uriniferous tubules or 'Malpighian bodies'. In 1842, Sir William Bowman (1816–1892) published his observations on the circulation through the Malpighian bodies, providing evidence that the glomerular corpuscle is continuous with the renal tubule. He described the vascular supply of the nephron, and proposed a theory of renal secretion.

Nephrology

In 1764, Domenico Cotugno (1736–1822), in a treatise on sciatica, described an association between edema and proteinuria.

In 1812, William Charles Wells (1757–1817) noticed the '*presence of the red matter and serum of blood in the urine of dropsy, which has not originated from scarlet*' and that among patients with dropsy, the edema occurred in the upper parts of the body. He also described uremic seizures.

Then, in 1827, Richard Bright (1789–1858) described chronic non-suppurative nephritis, *Bright's disease*. Bright also distinguished renal from cardiac edema.

Professor Carl Friedrich Wilhelm Ludwig (1816–1895) wrote a classic monograph on renal secretion, *Beitrage zur Lehre vom Mechanismus der Harnsecretion* (Marburg, NG Elwert 1843), in which he theorized that blood hydrostatic pressure in glomerular capillaries led to the separation of protein and cell-free fluid from blood by a process of filtration. This controversial theory contradicted Bowman's contention that the glomerulus secretes fluid. In 1857, Charles Edward Isaacs (1811–1860) confirmed Ludwig's proposition. He concluded that the Malpighian bodies are important in the secretion of urine (*Trans NY Acad Med* 1857; **1**: 437–456).

In 1859, Claude Bernard (1813–1878) described an effect of the renal nerves on urine flow.

Renal surgery

By the end of the nineteenth century, surgical horizons had been extended by the discovery of anesthesia.

Charles L Stoddard described the first nephrectomy as undertaken in error by Erastus Bradley Wolcott (1804–1880). It was only after the operation for tumor that the surgeons realized that they had removed the kidney and its tumor.

Gustav von Simon (1824–1876) performed the first elective nephrectomy for a urinary tract fistula, and the first for renal tumor was done in 1877 by Karl Johann August Langenbuch (1846–1901).

In 1896, the first planned nephrostomy was carried out by Joaquin Maria Albarran y Dominguez (1860–1912).

In 1902, Emerich Ullman (1861–1937) was able to report the successful autotransplantation of kidneys in dogs. Alexis Carrel (1873–1944) developed arterial anastomoses, and by 1905, was able to report the first heart transplant. In 1908, Carrel successfully transplanted the kidney from one animal to another.

Renal endocrinology

In 1898, Robert Adolf Armand Tigerstedt (1853–1923) and Per Gustaf Bergman (1874–1955) discovered that a pressor substance (renin) is produced by the kidneys and enters the circulation via the renal veins.

1910: Rudolf Magnus (1873–1927) and Ernest Henry Starling (1866–1927) reported that pituitary extracts caused a marked and often prolonged diuresis, suggesting a role for the neurohypophysis in urinary regulation.

Renal investigations

1. 1906: Pyelography was introduced by Alexander Von Lichtenberg (1880–1949).
2. 1919: Changes in urine pH with renal disease were first recognized by John Beresford Leathes (1864–1956) with his description of *alkaline urine in nephritis* (*BMJ* 1919; **2**: 165–167).
3. 1920: The urea concentration tests were introduced by Hugh MacLean (1879–1957) and Owen Lambert Vaughan de Wesselow (1883–1959) (*Br J Exp Pathol* 1920; **1**: 53–65).
4. 1928: Urea clearance tests were described by Eggert Hugo Heiberg Möller.
5. 1886: Creatinine measurements. Max Jaffe (1841–1911) had devised a method for measuring creatinine in blood, which was later improved by Stanley Benedict (1884–1936).
6. 1928: The prognostic importance of a rise in blood creatinine was described by Frank Patch and I.M. Rabinowitch.
7. 1926: Poul Brandt Rehberg (1895–1985) made the assumption that creatinine was exclusively excreted through glomeruli, and proposed that by measuring creatinine in urine and blood, one could derive a glomerular filtration rate in man from the clearance rate of creatinine (*Biochem J* 1926; **20**: 447–482).

Physiology

1. 1924: Joseph Treloar Wearn (1893–1984) and Alfred Newton Richards (1876–1966) proposed that glomerular filtration produces a protein-free ultrafiltrate of plasma, and that reabsorption of certain substances must occur in the tubules.
2. 1924: Starling and Ernest Basil Verney (1894–1967) demonstrated the antidiuretic effects of vasopressin directly on the kidney, and demonstrated that the tubules of the kidney reabsorbed water.
3. 1924: Alfred Newton Richards and Carl Frederic Schmidt (1893–1988) described the influence of adrenaline on the glomerular circulation.
4. 1927: Joseph Marchant Hayman described estimates of afferent arteriole and glomerular capillary pressures in the frog kidney.

5. 1929: Eli Kennerly Marshall (1889–1966) showed that the renal tubules of a vertebrate could secrete foreign substances.
6. 1931: Guido Fanconi (1892–1979) showed that the profound dysfunction of renal tubules in children was characterized by hypophosphatemia, renal glycosuria, and metabolic disturbances.
7. 1947: Verney introduced the concept of osmoreceptor-related ADH release.

Pathophysiology

Intensive care nephrology is dominated by episodes of acute renal dysfunction secondary to hypovolemic and toxic processes. These processes were highlighted by Eric Bywaters and Desmond Beall, who described 'crush syndrome' among victims of the London air raids of 1940–1941. This is the first classic paper reviewed (see below).

Dialysis

Management of renal failure before dialysis was conservative, and patients were expected to die from the complications of acute renal failure. Therefore, the development of dialysis was a huge landmark in the management of renal dysfunction.

1. 1861: Thomas Graham (a Glasgow chemist) undertook the first experiments on dialysis, describing the liquid diffusion of various substances across a parchment membrane.
2. 1913: Pioneers in dialysis included John Jacob Able (1857–1938), Leonard George Rowntree (1883–1959), and Benjamin Bernard Turner (b 1871), who described the use of dialysis to remove blood-borne substances in animals. In 1937, Thalheimer used cellophane as a membrane and heparin as the anticoagulant.
3. 1943: Willem Johan Kolff (b 1911) constructed and used the first artificial kidney. H.T.J. Berk, N. Alwall, L.T. Skeggs, and J.R. Leonards all contributed to further modifications of the artificial kidney design.
4. In 1956, Kolff and Watschinger described the use of a twin coil kidney to treat uremia in two patients, and this dialyser/ultrafiltration construction became the basis for a commercially available and disposable artificial kidney.
5. 1960: The indwelling Teflon silastic arteriovenous shunt allowed access to the circulation for repeated hemodialysis – Wayne E. Quinton, D. Dillard and B.H. Scribner.
6. 1877: Peritoneal dialysis was investigated by Friederich Rudolf Georg Wegner (1843–1917), and later by the Dutch physiologist Hartog Jakob Hamburger (1859–1924) in 1895.
7. 1923: Experimental use of peritoneal dialysis in uremia by G. Ganter.
8. 1946: Peritoneal dialysis was used for the treatment of acute renal failure, as described by Jacob Fine with H.A. Frank and A.M. Seligman.
9. Peritoneal irrigation was described for management of incompatible blood transfusion and poisoning.
10. 1962: John Putnam Merrill (1917–1986) invented a plastic conduit for placement into the peritoneum for repeated peritoneal lavage.

Transplantation

1. 1950: The first human patient to survive a kidney transplant was on June 17, reported by Richard H. Lawler (1895–1982).
2. 1955: Nine cases of renal homotransplantation – David Milford Hume (1917–1973), with J.P. Merrill, B.F. Miller, and G.W. Thorn (*J Clin Invest* 1955; **34**: 327–382).
3. 1956: The first successful kidney transplant was a homotransplant between identical twins (no immunosuppression) – J.P. Merrill, with J.E. Murray, J.H. Harrison, and W.R. Guild.

This brief history sets the scene for the classic papers of more recent years.

Title

Crush injuries with impairment of renal function

Author

Bywaters EGL, Beall D

Reference

BMJ 1941; 22 March: 427–432

Abstract

Four cases of crush injury to limbs producing shock are described in which after recovery, due to replacement of circulatory fluid, the patients showed oliguria and pigment casts. They died in about one week with nitrogen retention. Necropsy revealed degenerative changes in the proximal convoluted tubules, and pigment casts in the more distal part of the nephron. The etiology and possible lines of treatment are discussed.

Summary

This paper describes in some detail the clinical manifestations of severe crush injury among four London air-raid casualties during World War II. The descriptions include the well-recognized observations of hemorrhagic shock, namely severe vasoconstriction associated with pallor, diaphoresis, and coolness of the peripheries, with hypotension and normal, if not elevated, hemoglobin concentration; the latter becoming diluted on fluid administration. However, what was remarkable about these four cases was that hypotension was considered relatively short-lived, and yet all four patients were oliguric and remained so despite relatively brisk restoration of circulating volume and blood pressure. All four patients died with sudden decompensation, which was primarily of a cardiac nature. Death occurred on the third, sixth, seventh, and eighth days in these patients, and in those that died after the third day, the blood pressure fell in association with evidence of progressive ECG changes suggestive of hyperkalemia. All patients had signs and symptoms that could be related to uncontrolled acute renal failure, such as vomiting due to urea and ileus, rising potassium, and fluid retention. Renal necropsy findings described in great detail the relatively swollen macroscopic appearance of the kidneys, relative sparing of the glomeruli, but clear evidence of severe proximal tubular degeneration with similar distal tubule changes. There were brown pigmented casts composed of desquamated epithelial cells. The pigment was considered to be from myohemoglobin (myoglobin), probably from muscle necrosis given the history in their four cases.

There are interesting references to practices that have survived to this day. The recognition that restoring plasma volume (saline, plasma, and hypertonic saline) and regaining blood pressure (by use of pitressin) are an essential part of trying to restore glomerular filtration, while diuretics (in this case caffeine) were used to promote urine volume. The overall documentation of vital signs and physiological measurement suggest that these patients received high dependency observation as appropriate to the severity of their illness.

Citation count 547

Related references

1. Colmers DR. *Archiv für Klinische Chirurgie* 1909; **90**: 701–747. [This describes the association of acute renal failure with crushed limbs in victims of the Messina earthquake on 28 December 1908.]

2. Minami S. *Virchows Archives of Pathological Anatomy and Histopathology* 1923; **245**: 247. [This paper alludes to body pigments being a cause of acute renal failure, although an earlier reference to this had been made by Bell in 1900 who described four cases of acute renal failure after incompatible (kell antibodies) blood transfusion.]
3. Jackson RC, Woodruff AW. *BMJ* 1962; **1**: 1367–1372. [This is the first description of the use of dialysis to treat pigment nephropathy.]
4. Oliver J, MacDowell M, Tracy A. *J Clin Invest* 1951; **30**: 1305–1439. [This work on the structural lesions associated with acute renal failure following traumatic and toxic injury was able to differentiate between the two types of damage: nephrotoxic due to toxic substances, and tubulorhexic, due to ischaemia.]

Key message

The release of myoglobin from crushed muscle may lead to acute renal failure in spite of adequate circulatory resuscitation or removal of the crushed limb. Although hypovolemia and blood transfusion reactions might be simultaneous events at the time of rhabdomyolysis, the latter should be considered as a cause of continuing oliguria.

Why it's important and clinical relevance

This paper was the first English language communication in which acute renal failure was associated with the release of myoglobin following muscle necrosis. Previous descriptions by Colmers and others (Frankenthal L. *Virchows Archives* 1916; **222**: 332) had also associated acute renal failure with crush injury. These authors recognized that the pattern of renal damage was similar to other pigment damage, such as that of free hemoglobin in mismatched blood transfusion. The study by Bywaters and Beall confirmed that acute renal failure could be solely the result of tubular damage. The mechanism of damage has since been confirmed, and has been the subject of a significant research effort in view of its considerable military importance. This led to the observation by Ron *et al.* (Ron D, Taitelman U, Michaelson M *et al. Arch Intern Med* 1984; **144**: 277–280) that saline rehydration and increasing urinary pH with bicarbonate reduces the dissociation of myoglobin to globin and ferrihemate, which is toxic, as well as reducing uric acid precipitation. Ferrihemate, or at least its associated free iron, has since been implicated as a cause of tubular nitric oxide/endothelin imbalance.

Strengths

Clarity of message, clinical findings supported by histology, the pathophysiology remains as true today as it did at the time of publication. Observations have since been confirmed.

Weaknesses

The paper comprises case reports.

Title

Studies of the antidiuresis of quiet standing: the importance of changes in plasma volume and glomerular filtration rate

Author

Epstein FH, Goodyer AVN, Lawrason FD, Relman AS

Reference

J Clin Invest 1951; **30**: 63–72

Abstract

Not available

Summary

This paper describes a group of experiments undertaken in healthy young males. In the first experiment, three subjects spent 30- or 60-minute sequential periods either standing or supine. Renal plasma flow, urine flow, water, and sodium excretion all decreased in the standing period, and continued even when the supine position was resumed. A second experiment was conducted in four further subjects in whom 4% albumin in normal saline (three patients) or 25% albumin was given before standing, to determine whether the urine volume and sodium excretion changes could be prevented. The results suggested little protective effect. In a further experiment, seven patients were given 6% hypertonic saline by infusion to determine how plasma volume, plasma sodium concentration, and sodium filtration were related to urinary sodium loss while standing. The results showed that although plasma sodium concentration rose significantly, most patients did not increase their urinary sodium loss while standing, suggesting a powerful mechanism continuing to retain sodium. The small patient numbers and reporting of the findings on a case by case basis initially make interpretation difficult. However, at the time of this study, it was well known that assumption of the standing position resulted in a reduction in urine output, sodium excretion, and glomerular filtration, due to reduced blood flow to the kidneys. The mechanism for sodium retention was not understood. It was known that in such patients the physiological change probably resulted from pooling of blood and could be largely minimized by water immersion; suggesting that although absolute circulating volume might not have changed, effective circulating volume had reduced. This study first confirmed the effect of standing – independent of changes in sodium. It then tried to separate the effect of volume change from that of an increased blood sodium concentration on these same observations. The study demonstrates that the kidney is more influenced by effective circulatory changes than by the prevailing plasma sodium concentration.

We now know that the kidney prioritizes absolute and effective circulating volume changes above osmotic disturbances through complex neuroendocrine compensatory mechanisms throughout the cardiovascular and renal system.

Citation count

95

Related references

1. Schrier RW. *N Engl J Med* 1988; **319**: 1065–1072.
2. Schrier RW. *N Engl J Med* 1988; **319**: 1127–1134.
3. Schrier RW, Gurevich AK, Cadnapaphornchai MA. *Semin Nephrol* 2001; **21**: 157–172.

[These three articles propose a unifying pathophysiological role for the kidney in the development of sodium and water retention leading to edema in conditions where effective circulating volume is reduced. These conditions include low output circulatory failure and high output circulatory failure (cirrhosis, arteriovenous fistula, volume resuscitated sepsis), where the effective circulating volume appears to become independent of absolute extracellular or plasma volume.]

Key message

1. A fall in urine output and sodium retention is not only associated with an absolute fall in plasma volume.
2. Hypertonic saline can prevent a fall in urine output without leading to additional urinary sodium loss.
3. Sodium control by the kidney is not solely dependent on sodium plasma concentration or glomerular sodium filtration.

Why it's important and clinical relevance

This study takes us one step further toward the concept of effective circulating volume and the complex response of the kidney to changes in such volume. It demonstrates that kidney sodium loss is not just a measure of circulating sodium concentrations or loads, but is more importantly related to the need for maintaining a circulating volume. In fact, it highlights the body prioritizing volume control over osmolality control. This is the basis to an understanding of the pathophysiology, and therefore the therapeutic aims in conditions such as congestive cardiac failure, cirrhosis, and nephrosis.

Strengths

When placed in historical context, this study presents a structured exploration of the role played by circulatory volume changes and plasma sodium concentrations in the control of renal sodium losses.

Weaknesses

Small numbers of patients, no randomized cross-over design for periods of standing and supine positions.

Title

Aspirin-induced depression of renal function

Author

Kimberly RP, Plotz PH

Reference

N Engl J Med 1977; **296**: 418–424

Abstract

We observed elevation of serum creatinine and blood urea nitrogen and decrease in creatinine clearance in patients taking anti-inflammatory doses of aspirin. In 13 of 23 patients with systemic lupus erythematosus, increases in serum creatinine ranged from 27 to 163 percent, and those in urea nitrogen from 42 to 270 percent. Sequential creatinine-clearance studies, available in 11 of the 13 patients, demonstrated decreases up to 58 percent. Patients with aspirin-induced changes in renal function were more likely to have active renal disease ($p = 0.035$) or hypocomplementemia ($p = 0.30$). Four of 22 patients with rheumatoid arthritis, and two of three normal volunteers also demonstrated biochemical changes. The rate of aspirin-induced alterations were significantly higher in systemic lupus erythematosus ($p = 0.007$) than in rheumatoid arthritis.

Aspirin, and other nonsteroidal anti-inflammatory agents, can have a major reversible effect on renal function that may influence the interpretation of clinical data.

Summary

This paper describes two case histories of young females with systemic lupus in whom renal function deteriorated with long-term aspirin treatment. These observations led to a prospective study in three groups of patients (Figure). The first group included 21 patients with systemic lupus, the second group comprised 22 patients with rheumatoid arthritis, and the third was a small group of normal volunteers. All patients were used as their own controls within the groups, and exposed to periods with and without aspirin therapy. A significant within-patient effect of aspirin was based on changes in serum creatinine exceeding the 95% confidence limits. Patients with significant creatinine changes were classed as reactors to aspirin. Of the 48 patients examined, 19 patients were reactors. Reversibility was shown in all nine of the reactor patients for whom complete data were available. The authors noted that in those with lupus nephritis or hypocomplementemia, there was a greater likelihood of being a reactor to aspirin. They also noted that patients receiving indomethacin and naproxen had similar renal changes.

Citation count 216

Related references

1. Vane JR, Anggard EE, Botting RM. Regulatory functions of the vascular endothelium. *N Engl J Med* 1990; **323**: 27–36.
 2. Mitchell JA, Akarasereenont P, Thiemermann C, Flower RJ, Vane JR. Selectivity of nonsteroidal anti-inflammatory drugs as inhibitors of constitutive and inducible cyclooxygenase. *Proc Natl Acad Sci USA* 1993; **90**: 11693–11697.
 3. De Broe ME, Elseviers MM. Analgesic nephropathy. *N Engl J Med* 1998; **338**: 446–452.
- [These three papers review the role of prostaglandins and their inhibition.]

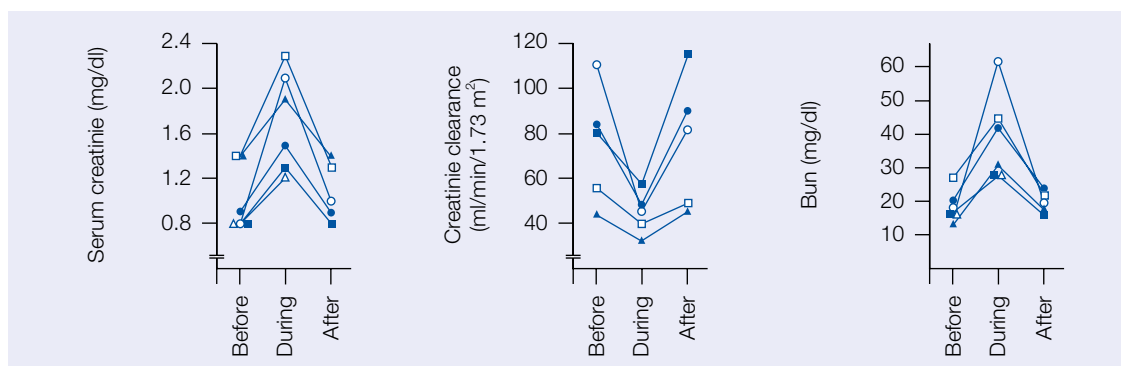

Fig. 6.1. Changes in renal function measurements in patients with systemic lupus erythematosus during aspirin administration. Six of 13 reactors are shown in detail. Each symbol denotes an individual patient. In all patients except the one designated by the open triangle, the reversibility of the aspirin-induced effects was documented. For the sake of clarity the other seven reactors are not included (Adapted from the original article.)

Key message

Aspirin and agents that inhibit renal prostaglandin production can potentially lead to deterioration of renal function.

Why it's important and clinical relevance

The suspicion that aspirin alters renal function had been known since its documentation by Hanzlik and Scott in their series of articles on salicylates in the early 1900s. They described salicylate therapy-induced salt and water retention causing 'salicyl edema'. This particular article is a landmark because not only did it describe, by way of case history, deterioration in renal function among patients receiving daily aspirin, but it went on to demonstrate with a prospective within-patient controlled study the deterioration and reversal of aspirin-induced renal dysfunction. Furthermore, it strongly suggested that aspirin and non-steroidal drugs might injure the kidney through mechanisms that inhibited intrinsic renal prostaglandins, leading to glomerular vascular dysfunction. Since that time, this message has become stronger by numerous accounts of non-steroidal-induced acute renal failure. The mechanism has been confirmed to be predominantly through cyclooxygenase (COX) inhibition and reduction in endogenous renal prostaglandin production. It has since been discovered that there are two isoforms of the COX enzyme, COX-1 and COX-2. COX-1, the constitutive enzyme, maintains normal prostaglandin (PGE₂ and PGI₂) and thromboxane activity in stomach, intestine, kidneys, platelets, and vascular endothelium. COX-2 is the inducible enzyme that is produced in response to injury and is present at sites of inflammation and pain. Inhibition of both COX enzymes reduces inflammation at risk of upsetting prostaglandin-controlled vascular mechanisms in the kidney. Research has therefore been directed towards non-steroidal anti-inflammatory agents that have predominantly anti-COX-2 activity, thereby potentially reducing renal and intestinal side effects normally consequent to anti-COX-1 activity.

Strengths

This study put beyond doubt the adverse relationship between analgesics and renal function with a within-patient controlled study. This message has since been strengthened by further studies, and evidence from day-to-day clinical practice.

Weaknesses

A significant number of patients had incomplete data, and all the patients had some predisposing cause for renal dysfunction; however, the changes and their reversibility were dramatic enough to exclude other possible causes for the adverse effects.

Title

Adenosine production in the ischemic kidney

Author

Miller WL, Thomas RA, Berne RM, Rubio R

Reference

Circ Res 1978; **43**: 390–397

Abstract

We conducted experiments to determine (1) tissue, blood, and urine levels of adenosine produced by the ischemic kidney under conditions of renal artery occlusion, and (2) the site(s) of production and release of adenosine by the kidney. Concentrations of adenosine, inosine, and hypoxanthine in the dog urine were found to increase after 2 minutes of renal artery occlusion, as were concentrations of these metabolites in renal tissue after 10 minutes of renal artery occlusion. Renal venous plasma levels of inosine and hypoxanthine also were elevated after 3 minutes of arterial occlusion. In modified stop-flow experiments, adenosine appeared in the urine in a peak that corresponded most closely with proximal tubule fluid. 5'-nucleotidase, the enzyme which catalyzes the dephosphorylation of 5'-AMP or 5'-IMP to adenosine or inosine, respectively, was found to be located primarily on the external membranes and mitochondria of proximal tubule cells, but not in distal tubule or collecting duct cells. Since adenosine has been demonstrated to elicit renal vasoconstriction and is produced by ischemic kidney, it is suggested that adenosine may be involved in the mediation of postocclusion renal ischemia.

Citation count 169

Related reference

1. Osswald H, Hermes H, Nabakowski G. *Kidney Int* 1982; **22** (Suppl 12): S136–S142. [This paper proposes a role for adenosine in signal transmission of the tubuloglomerular feedback mechanism.]

Key message

Adenosine is released by ischemic kidneys and most likely has a role in glomerular vascular control.

Why it's important and clinical relevance

Previous to this study, there was evidence that adenosine and its nucleotides were vasodilators in heart and skeletal muscle. However, adenosine was noted to induce renal vasoconstriction in salt-restricted rats, while in salt-loaded rats, there was no adenosine-induced vasoconstriction. The further observation that dipyridamole (an agent that increases adenosine concentrations by limiting its uptake by tissues) further increased the effect of adenosine led to exploration of the role of adenosine in renal ischemia.

The results of this early paper on peptide mediators suggested that renal adenosine concentrations were elevated following renal ischemia, and might be involved in renal vascular control mechanisms. Osswald later proposed that adenosine mediated a fall in GFR in response to elevated sodium or chloride levels in the juxtaglomerular apparatus.

Thus, the first steps were taken to elucidate the mediators of the tubuloglomerular feedback over and above the hitherto known release of renin. Adenosine was later shown to be a mediator of glomerular vasoconstriction, and with prostaglandins, renin, angiotensin, and the renal sympathetic nervous system, formed part of a complex integrated mechanism which controls glomerular filtration. Since the early 1990s, further mediators, i.e. endothelin and nitric oxide, have been discovered, and now it has become clearer that the changes in glomerular vascular activity and mesangial cell contraction in response to an ischemic insult are consequent to the actions of all these mediators. The modification of these agents is currently providing a basis for further research in the quest to reduce the incidence of acute oliguric renal failure.

Strengths

This paper, which is a little difficult to read, nevertheless elegantly demonstrated (with controls in three animal species) the rise in adenosine concentrations in response to renal ischemia. The quantitative estimates of adenosine after ischemia in this study were in the same range as exogenous concentrations known to result in vasoconstriction. This observation very much strengthened the proposition that endogenous adenosine may play a role in glomerular vascular control.

Weaknesses

None

Title

Management of anuric intensive-care patients with arteriovenous hemofiltration

Author

Kramer P, Kaufhold G, Gröne HJ, Wigger W, Rieger D, Matthaei D, Stokke T, Burchardi H, Scheler F

Reference

Int J Artif Organs 1980; **3**: 225–230

Abstract

It may be concluded from our results to date, that arteriovenous hemofiltration is an accurate and reliable method for the management of fluid balance in patients resistant to diuretics. Early use of this method may improve the prognosis of intensive-care patients by decongestion or dehydration of lungs, reduction of cardiac pre- and after-load, and unrestricted infusion therapy for prevention of catabolism. In addition, the method has been shown to be useful for compensation of uremia, and particularly for hypernatremia. The fact that this method requires no investment costs might be of particular interest to many intensive-care units which cannot afford expensive hemodialysis or hemofiltration machines.

Summary

This paper describes 2 years' experience using a new technique for continuous renal replacement therapy in 14 critically ill patients aged 5–74 years. Five of 14 patients survived hospital and recovered renal function. However, the authors' experience included some 73 patients since the introduction of the technique in 1977, which were not detailed. The report describes the use of arterial and venous cannulae connected to a TM 30 ultrafilter supplied by Amicon Corp. The filter was driven by the patient's blood pressure and anticoagulated with 1000 units heparin per hour delivered into the arterial blood line before reaching the filter. Ultrafiltrate was collected at a vertical distance 40 cm below the filter. The filter separated all plasma water and unbound substances with molecular weight below 10,000 Daltons from blood, and replacement fluid containing lactate at 40 mEq/L was used to replenish circulating volume as clinically appropriate. The authors demonstrated that the duration of hemofilter function was closely related to the degree of anticoagulation. They also observed that the ultrafiltration rate was a function of the arterial blood flow rate. As a rule, the filtration rate was 25% of the blood flow.

Citation count

86

Related references

1. Kramer P, Wigger W, Rieger J, Matthaei D, Scheler F. Arteriovenous hemofiltration; a new simple method for treatment of overhydrated patients resistant to diuretics. *Klin Wochenschr* 1977; **55**: 1121–1122.
2. Geronemus R, Schneider W. Continuous arteriovenous hemodialysis; a new modality for the treatment of acute renal failure. *Trans Am Soc Artif Intern Organs* 1984; **30**: 610–613.
3. Tam PY, Huraib S, Mahan B *et al*. Slow continuous hemodialysis for the management of complicated acute renal failure in an intensive care unit. *Clin Nephrol* 1988; **30**: 79–85.
[These studies are among the earliest descriptions of other various forms of continuous dialysis.]

Key message

Replacement of renal function by a continuous method of hemofiltration can be used successfully in critically ill patients.

Why it's important and clinical relevance

This paper is one of a number of publications, some of which were in non-English language journals, that described the pioneering experiences of the Göttingen group, led by Peter Kramer, with continuous hemofiltration in the critically ill.

After the introduction of hemodialysis in 1943 by Kolff (Kolff WJ, Berk HTJ. *Ned Tijdschr Geneesk* 1943; **87**: 1684–1692), its successful use following injury in the military field (Smith LH, Post RS *et al.* *Am J Med* 1955; **18**: 187–198) firmly established hemodialysis as the mainstay therapy for acute and chronic renal failure. However, it was soon recognized as being less suitable for hemodynamically unstable critically ill patients than the chronic renal failure patient. At the time, there was some interest in hemofiltration with new filters as an alternative to dialysis (Quellhorst E, Fernandez E, Scheler F. *Proc Eur Dial Transplant Assoc* 1972; 9584–9587; Henderson LW, Silverstein ME, Ford CA, Lysaght MJ. *Kidney Int Suppl* 1975; 58–63).

Kramer treated a patient in May 1977 with continuous arteriovenous hemofiltration after apparently inadvertently cannulating the femoral artery rather than vein. He noted that the heart was sufficient to pump the extracorporeal blood through a filter. The advantage of such a system was that there was no need for a blood pump, nor for sophisticated control of the extracorporeal circulation. There was a simple method for fluid replacement, which was of Hartmann's type composition. The ability to run such a system with continuous heparin allowed the circuit to be maintained for several hours. CAVH achieved FDA approval in 1982. However, the efficiency of CAVH systems was still not as good as intermittent dialysis machines for hypercatabolic patients. There were inevitably problems with AV systems, e.g. bleeding from arteries, fluid balance vagaries, and rising creatinine and urea when filtration rates, which were pressure dependent, fell. Two major developments followed. First, the introduction, initially in Cologne, of continuous veno-venous hemofiltration (CVVH) in 1979, which allowed more control of filtration rates, and then in 1984 Geronemus and Schneider described arteriovenous continuous hemodiafiltration (CAVHD), which enabled a more efficient removal of low molecular products such as urea and creatinine.

Inevitably, the arteriovenous hemodiafiltration system was applied by Tan in 1988 to a veno-venous system (CVVHD). Since the premature death of Peter Kramer in 1984, the use of continuous hemodiafiltration has evolved rapidly to becoming the method of choice for dialysis of the critically ill patient. The enormity of this advance is immeasurable. There have been savings in specialist dialysis nursing costs, and its simplicity has allowed widespread availability of dialysis from larger teaching hospitals to smaller district hospitals without need for tertiary referral. Current methodology provides accurate fluid balances with hemodynamic stability during management.

Strengths

The paper provided evidence that continuous hemofiltration works.

Weaknesses

This was a case study, and therefore suffered from the lack of control data.

Title

Selective vulnerability of the medullary thick ascending limb to anoxia in the isolated perfused rat kidney

Author

Brezis M, Rosen S, Silva P, Epstein FH

Reference

J Clin Invest 1984; **73**: 182–190

Abstract

A specific anatomical lesion sharply localized to the cells of the medullary thick ascending limbs (mTAL), and characterized by mitochondrial swelling progressing to nuclear pyknosis and cell death is elicited reproducibly in isolated rat kidneys perfused for 15 or 90 minutes with cell-free albumin-Ringer's medium gassed with 5% CO₂, and 95% O₂ (O₂ content 1.5 vol/100 ml). The lesion, involving about half of mTALs, appears first in mTALs removed from vascular bundles and near the inner medulla, areas most likely to be anoxic. Hypoxic perfusion (O₂ content 0.12 vol/100 ml) exaggerates the lesion, wiping out gradations of damage and extending it to all mTALs. O₂-enriched perfusions using rat erythrocytes (O₂ content 7.1 vol/100 ml) completely eliminates the lesion (unless gassed with carbon monoxide). Similarly, supplementation of the perfusion medium with a purified hemoglobin (O₂ content 5.8 vol/100 ml) prevents mTAL injury. Perfusion with a fluorinated hydrocarbon blood substitute, Oxypherol (O₂ content 4.3 vol/100 ml), also attenuates the lesion.

These findings suggest that the mTAL is exquisitely susceptible to anoxic damage because of low O₂ supply imposed by the medullary vascular system, and the high rate of metabolism mandated by active reabsorption of sodium chloride. The vulnerability of the mTAL to anoxic injury could play a key role in the pathogenesis of ischemic renal injury.

Summary

This controlled animal study was undertaken to evaluate the reasons why isolated perfused kidneys that were being used for other experiments were rapidly developing tubular necrosis, particularly in the medullary thick ascending limb. Another observation at the time was that there was an association between the redox state of cytochrome aa3 in the perfused kidney, and the presence or absence of frusemide in the perfusate. The change in redox state suggested that frusemide altered the prevailing oxygen tension. The idea therefore evolved that changes in oxygen tension were the possible cause of cellular damage during perfusion. These studies were carried out in the isolated perfused kidneys of Sprague-Dawley rats using a control group, a group exposed to hypoxic perfusate, and a further group in which the perfusions were oxygen-enriched, either through erythrocytes, free hemoglobin, or a fluorinated carbon emulsion capable of carrying oxygen. In this oxygen-enriched group, there were a further two animals perfused with erythrocytes exposed to carbon monoxide sufficient to reduce oxygen carriage to low levels. Perfusions continued for 90 minutes, and the kidneys were examined by electron microscopy in a blinded manner. An average of 137 tubules per kidney, and 61 kidneys were examined. The kidney histology was examined in standard zones to avoid topographical bias.

The results were both consistent and definitive. They showed that the degree of necrosis (percentage of tubules) was greatest and more extensive in animals with hypoxic perfusates, or perfusates in which oxygen carriage was reduced by carbon monoxide.

In these animals, it was also greater in zones further from the vascular bundle (transverse gradient), and in zones where oxygen tensions were lowest, e.g. in the deepest portions of the mTAL in the inner medulla (axial gradient). In animals perfused by any of the oxygen carriage-enhancing methods, there was no evidence of necrosis. This was powerful evidence that oxygen tension was directly related to the development of necrosis. The authors proposed that the mTAL was akin to the myocardium, where the balance between oxygen supply and delivery was critical to normal function. The mTAL has a low oxygen tension (10 mmHg), which, if further reduced, leads to damage and initially poor concentrating ability, increased sodium delivery to the distal tubule, and consequent increase in tubuloglomerular feedback, leading to progressive glomerular shut-down.

Citation count 204

Related references

1. Brezis M, Rosen S. Hypoxia of the renal medulla. Its implications for disease. *N Engl J Med* 1995; **332**: 647–655.
[This paper explores the concept of renal tubular angina.]

Key message

An important mechanism for tubular dysfunction and later glomerular shut-down is a reduction in medullary oxygen tension.

Why it's important and clinical relevance

The concept of renal tubular angina is clinically important because it suggests that it might be reversible. Many factors related to renal dysfunction – such as NSAIs, radiocontrast media, aminoglycosides, ACE inhibitors, hypertension, and diabetes – predispose to renal damage, in part through alteration of normal vasoactive controls. These controls are mediated or modified through agents such as prostaglandins or their precursors, nitric oxide, endothelin, or adenosine. Acute renal failure is usually the combination of these predisposing conditions complicated by hypovolemia, which together result in critical perfusion and oxygenation of the kidneys. Although the hypovolemic insults are met by a compensatory mechanism which aims to retain medullary perfusion, this may be overwhelmed, and results in oliguria. The demonstration of an anginal state in the tubule raises the potential for reversibility with use of rapid restoration of normal hemodynamics and appropriate mediators possibly limiting the ischemic insult.

Strengths

Methodical controlled analysis of the problem of tubular ischemia in an isolated perfused kidney model. Conclusive results providing a new perspective on renal tubular behavior.

Weaknesses

None.

Title

Biocompatible membranes in acute renal failure: prospective case-controlled study

Author

Schiffel H, Lang SM, König A, Strasser A, Haider MC, Held E

Reference

Lancet 1994; **344**: 570–572

Abstract

The mortality of critically ill patients with acute renal failure has been halved through intervention by hemodialysis. However, several reports suggest that the course of the disorder may be prolonged by this procedure. Our prospective randomized study was done to see whether the generation of inflammatory mediators by bio-incompatible membranes has an adverse effect on the outcome of acute renal failure.

Fifty two patients, similar in age, severity of acute renal failure, general disease status (APACHE II), and management of acute renal failure or its related conditions, were divided into two groups. Hemodialysis was done with cuprophane or polyacrylonitrile membranes. Cuprophane membranes induced intense activation of the complement system (as judged by measurement of C3a) and lipoxygenase pathway (leukotriene B4), resulting in alterations of neutrophil kinetics and function. The cuprophane group had a lower survival rate (38 vs 65%), a higher proportion of patients dying from sepsis (71 vs 40%), required more hemofiltration sessions (12 vs 9), and demonstrated delayed resolution and recovery from acute renal failure than the polyacrylonitrile group. The difference in mortality regarding lethal sepsis as cause of death was statistically significant.

Our observations indicate that the outcome of critically ill patients with acute renal failure may be influenced by bio-incompatibility reactions to the dialysis membrane. These results have direct implications for such patients on hemodialysis.

Summary

This study explored whether bio-incompatible membranes used in hemodialysis might contribute to morbidity in management of acute renal failure. The study included 52 patients studied prospectively who were randomized into two groups, one group receiving hemodialysis with cuprophane membranes and the other with polyacrylonitrile (AN69). The results showed that patients dialysed with cuprophane membranes had significantly higher complement activation measured by C3a activity, an increase in white blood cell counts, and significantly increased leukotriene LB4 production, a measure of lipoxygenase pathway stimulation. The cuprophane group had higher mortality (62% vs 35%); the main cause of death was sepsis. On the basis of these findings, the study, which was intending to recruit 106 patients in each group, was stopped early after recruiting 26 in each group.

Citation count 237

Related references

1. Hakim RM, Wingard RL, Parker RA. Effect of the dialysis membrane in the treatment of patients with acute renal failure. *N Engl J Med* 1994; **331**: 1338–1342.

Key message

Although hemodialysis is a life-saving procedure, it may also contribute to morbidity and mortality through non-renal events.

Why it's important and clinical relevance

There is already evidence that hemodialysis may paradoxically prolong the need for dialysis, possibly by promoting new renal lesions through episodes of hypotension (Solez *et al. Medicine* 1979; **58**: 362–376). However, this and the study by Hakim suggest that cytokine activation through dialyser membrane bio-incompatibility may result in further endothelial injury with adverse organ function. The exposure of leukocytes to bio-incompatible membranes and the circuit in general has been associated with impaired phagocytosis, neutropenia, platelet activating factor release, monocyte activation, and reduction in natural killer cells. This study raised the possibility of iatrogenicity, and has led to a change away from bio-incompatible membranes.

Strengths

Prospective randomized study with conclusive results.

Weaknesses

There is some concern that the two patient groups may not have been balanced in terms of severity of illness. A calculated risk of death was not done, and severity was based on raw APACHE II scores. Hence, the mortality figures may not be entirely related to the difference in dialysis membranes. Some of the adverse effects of cuprophane membranes may be related to the greater hemodynamic instability while on dialysis among these patients, which may have been because this group was sicker. Greater hemodynamic instability may have re-injured the kidneys and accounted for the more frequent treatments required in this group.

Title

Acute renal failure: a multivariate analysis of causes and risk factors

Author

Rasmussen HH, Ibels LS

Reference

Am J Med 1982; **73**: 211–218

Abstract

Accepted causes (acute insults) and risk factors for the development of acute renal failure were defined, quantitatively assessed, and tested for statistical significance in 143 patients with acute tubular necrosis. Sixty-two percent of patients had more than one acute insult, and 48 percent had more than one suspected risk factor. Hypotension, excessive aminoglycoside exposure, pigmenturia, and dehydration were identified as highly significant acute insults, while it was concluded that sepsis and administration of radiocontrast material could not be incriminated as causes of acute tubular necrosis. An additive interaction between acute insults was demonstrated, and the severity of acute renal failure was related to the number and severity of acute insults. Patients with oliguric renal failure had more severe acute insults than patients with nonoliguric renal failure. Pre-existing renal disease and chronic hypertension were significant risk factors, the latter only when hypotension had been one of the acute insults. An age of more than 59 years, gout and/or chronic hyperuricemia, diabetes, and long-term diuretic administration were not found to be significant risk factors.

Summary

This retrospective study is one of the earliest to have applied multivariate analysis to the causes of acute renal failure in hospital. The patients were all derived from referrals to the renal unit at the Royal North Shore Hospital in Sydney. The authors were able to classify patients based on good documentation. They had predetermined definitions for pre-existing renal disease, acute renal failure, oliguria, non-oliguria, hypotension (by use of an index which included the duration of hypotension), sepsis, excessive aminoglycosides, pigmenturia, liver disease, dehydration, and chronic hypertension. They were able to confirm a number of previous observations.

These observations included the following: acute renal failure is commonly the result of multiple insults, patients with pre-existing renal dysfunction are predisposed to acute renal failure with fewer insults, oliguric failure is usually the result of more severe insults and more likely to result in death, and hypotension is the most common and potent insult. The study not only detailed the combinations of insults, but also allocated a weight to each insult, which could be added to provide an overall insult value. These values in turn could be compared between selected groups of patients and subjected to statistical analysis.

Since this study, others have followed with logistic regression models which have inevitably identified further risk factors, such as non-steroidal agents, contributing to the multifactorial nature of acute renal failure.

Citation count

141

Related references

1. Shusterman N, Strom BL, Murray TG, Morrison G, West SL, Maislin G. Risk factors and outcome of hospital-acquired acute renal failure. Clinical epidemiologic study. *Am J Med* 1987; **83**: 65–71. [This study of acute hospital-acquired renal failure used logistic regression analysis to isolate associated factors and their estimated weights and compared matched cohorts with and without acute renal failure. The authors found that volume depletion, aminoglycosides (particularly in the elderly), congestive heart failure, radiocontrast exposure, and septic shock were potent risk factors for acute renal failure. The effect of volume depletion was markedly accentuated in those with diabetes. Hospital-acquired acute renal failure was associated with a marked increase in length of stay, and an increased risk of dying.]
2. Brivet FG, Kleinknecht DJ, Loirat P, Landais PJ. Acute renal failure in intensive care units – causes, outcome, and prognostic factors of hospital mortality; a prospective, multicenter study. French Study Group on Acute Renal Failure. *Crit Care Med* 1996; **24**: 192–198. [This prospective study from 20 intensive care units collected 360 patients in acute renal failure. The study used logistic regression analysis to determine prognostic factors for outcome in these patients. Renal replacement therapy was used in 174 patients. Two hundred and ten patients (58%) died during the hospital stay. Using stepwise logistic regression, seven variables were predictive of death. These variables were advanced age, altered previous health status, hospitalization before ICU admission, later onset of acute renal failure, sepsis, oliguria, and severity of illness (SAPS, APACHE II, or Organ System Failure) at the time of study inclusion.]
3. Liano F, Pascual P, and The Madrid Acute Renal Failure Study Group. Epidemiology of acute renal failure (ARF): a prospective, multicenter, community-based study. *Kidney Int* 1996; **50**: 811–818. [This prospective study explored the epidemiology of acute renal failure in a defined population (4.2 million people over the age 14 years) admitted to 13 tertiary care hospitals in Madrid over 9 months. Of the 665 patients with acute renal failure, 45% were ATN, 21% pre-renal, 12.7% acute on chronic, and 10% obstructive. Renal function was normal at admission in 48% of patients who later developed ARF. Once corrected for the underlying disease process, mortality due to ARF was estimated at 26.7%. Dialysis was required in 36% of patients, and was associated with a significantly higher mortality (65.9 vs 33.2%, $p < 0.001$). Mortality was higher in patients with coma, assisted respiration, hypotension, jaundice (all $p < 0.001$), and oliguria ($p < 0.02$). Notably mortality in patients hemodialysed with biocompatible membranes was similar to that observed with cellulose-based membranes (66% vs 59.5%, NS). See the study by Schiffl *et al.* earlier in this chapter.]

Key message

Acute renal failure is usually the result of multiple insults, and is most frequently associated with hypotension.

Why it's important and clinical relevance

This study has led to several similar studies, each of which has further explored the relationship between predisposing illness and insults. These factors have been quantified sufficiently to provide some prediction both of the likely incidence of acute renal failure, and its associated hospital outcome. The importance of such a study, and those that have followed, is that many of these factors are preventable. The observation that multiple insults are additive has led to modification of clinical practice, particularly with known insults such as contrast media, aminoglycosides, and non-steroidal analgesics.

Strengths

This study was the first to try and quantify the relative risk of factors associated with acute renal failure. The risk factors were well defined, and in particular addressed both the severity and extent of hypotension.

Weaknesses

This retrospective study had no controls without acute renal failure. For statistical purposes, identifying risk factors and their genuine impact would have been better with controls. Such studies allow the use of logistic regression analysis to not only isolate the factors, but also provide a quantifiable risk in patient cohorts exposed to the risk factors. This is useful for future studies. However, a prospective study designed to identify risk factors for renal failure using randomly included control patients would require very large numbers of patients. In the later similar study by Shusterman *et al.* (1), the authors overcame the need for analyzing large numbers by matching the patients who acquired acute renal failure with selected controls. That is, they only included controls that could be matched with the patients that had acquired renal failure by age, sex, baseline renal function, hospital, and hospital department.

Title***The effect of acute renal failure on mortality: a cohort analysis***

Author

Levy EM, Viscoli CM, Horwitz RI

Reference*JAMA* 1996; **275**: 1489–1494

Abstract

Objective: To determine if the high mortality in acute renal failure is explained by underlying illnesses (comorbidity).

Design: Cohort analytic study.

Setting: An 826-bed general hospital providing primary, secondary, and tertiary care.

Patients: From 16,248 inpatients undergoing radiocontrast procedures between 1987 and 1989, we identified 183 index subjects who developed contrast media-associated renal failure (defined as an increase in serum creatinine level of at least 25%, to at least 177 $\mu\text{mol/L}$ [2 mg/dL], within 2 days of receiving contrast material), and 174 paired subjects, matched for age and baseline serum creatinine level, who underwent similar contrast procedures without developing renal failure.

Main outcome measure: Death during hospitalization.

Results: The mortality rate in subjects without renal failure was 7%, compared with 34% in the corresponding index subjects with renal failure (odds ratio, 6.5; $p < 0.001$). After adjusting for differences in comorbidity, renal failure was associated with an odds ratio of dying of 5.5. Subjects who died after developing renal failure had complicated clinical courses characterized by sepsis, bleeding, delirium, and respiratory failure; most of these complications developed after the onset of renal failure. Deaths from renal causes were rare.

Conclusions: The high mortality in acute renal failure is not explained by underlying conditions alone. Renal failure appears to increase the risk of developing severe nonrenal complications that lead to death, and should not be regarded as a treatable complication of serious illness.

Citation count

378

Related references

1. Brivet FG, Kleinknecht DJ, Loirat P, Landais PJ. Acute renal failure in intensive care units – causes, outcome, and prognostic factors of hospital mortality; a prospective, multicenter study. French Study Group on Acute Renal Failure. *Crit Care Med* 1996; **24**: 192–198.
2. Douma CE, Redekop WK, van der Meulen JH *et al*. Predicting mortality in intensive care patients with acute renal failure treated with dialysis. *J Am Soc Nephrol* 1997; **8**: 111–117.

Key message

Acute renal failure has an independent attributable mortality over and above that related to the underlying condition. Those requiring renal replacement therapy have poorer outcomes than those in acute renal failure who do not.

Why it's important and clinical relevance

This is the first paper that has convincingly managed to separate the effect of acute renal failure on outcome from the effect of an underlying disease process complicated by acute renal failure on outcome. The prevailing opinion at the time, and one that to some extent still continues, was that acute renal failure is an innocent bystander reflecting severity of illness. Therefore, it was a strongly held view that mortality was related to the underlying illness, while there was no attributable mortality to the acquired renal failure. Phrases such as 'patients die with rather than from acute renal failure' were commonly quoted. The demonstration that renal failure worsens outcome, and that outcome is further worsened if replacement therapy is used, was a significant observation. It was notable that the worsened outcome was attributed to non-renal events.

The earlier observations that renal replacement therapy was associated with new histological lesions suggested that renal failure might be prolonged by dialysis (Solez K, Morel Maroger L, Sraer JD. The morphology of 'acute tubular necrosis' in man: analysis of 57 renal biopsies and a comparison with the glycerol model. *Medicine (Baltimore)* 1979; **58**: 362–376). Consequently, more clinicians now manage complications such as metabolic acidosis conservatively, while providing vigorous resuscitation to reverse oliguria, rather than automatically starting hemofiltration.

Strengths

Patient selection and statistical analysis were sound, and therefore, for a retrospective study, considerably minimized bias from differences in case mix.

This study examined patients in whom there was a single precipitating cause for acute renal failure. The study therefore avoided the criticism that the insults may have been multiple, or of differing severity. Furthermore, the study used matched patients as controls (without renal failure) who had similar ages, baseline creatinine, and contrast studies, for inclusion in a logistic regression analysis with those patients who did develop contrast media-related acute renal failure.

Weaknesses

Retrospective study.

Title

Low dose dopamine in patients with early renal dysfunction: a placebo-controlled randomised trial

Author

Australian and New Zealand Intensive Care Society (ANZICS) Clinical Trials Group

Reference

Lancet 2000; **356**: 2139–2143

Abstract

Background: Low-dose dopamine is commonly administered to critically ill patients in the belief that it reduces the risk of renal failure by increasing renal blood flow. However, these effects have not been established in a large randomized controlled trial, and use of dopamine remains controversial. We have done a multicenter, randomized, double-blind, placebo-controlled study of low-dose dopamine in patients with at least two criteria for the systemic inflammatory response syndrome, and clinical evidence of early renal dysfunction (oliguria or increase in serum creatinine concentration).

Methods: 328 patients admitted to 23 participating intensive-care units (ICUs) were randomly assigned a continuous intravenous infusion of low-dose dopamine (2 µg/kg/min) or placebo administered through a central venous catheter while in the ICU. The primary endpoint was the peak serum creatinine concentration during the infusion. Analyses excluded four patients with major protocol violations.

Findings: The groups assigned dopamine (n = 161) and placebo (n = 163) were similar in terms of baseline characteristics, renal function, and duration of trial infusion. There was no difference between the dopamine and placebo groups in peak serum creatinine concentration during treatment (245 [SD 144] vs 249 [147] µmol/L; p = 0.93), in the increase from baseline to highest value during treatment (62 [107] vs 66 [108] µmol/L; p = 0.82), or in the numbers of patients whose serum creatinine concentration exceeded 300 µmol/L (56 vs 56; p = 0.92), or who required renal replacement therapy (35 vs 40; p = 0.55). Durations of ICU stay (13 [14] vs 14 [15] days; p = 0.67) and of hospital stay (29 [27] vs 33 [39] days; p = 0.29) were also similar. There were 69 deaths in the dopamine group, and 66 in the placebo group.

Interpretation: Administration of low-dose dopamine by continuous intravenous infusion to critically ill patients at risk of renal failure does not confer clinically significant protection from renal dysfunction.

Summary

This study represents the first randomized prospective controlled study with sufficient patients to determine the influence of dopamine on renal function. This study was undertaken in all patients after there was a significant deterioration of renal function, and therefore explored the effect of dopamine as a treatment rather than as a prophylactic agent. The results of the study conclusively show that under the conditions of this study, dopamine administered at low dosage (2 µg/kg/min) to critically ill patients is no better than placebo at reducing the rise in creatinine, or the need for renal replacement therapy.

Citation count

203

Related references

1. Allgren RL, Marbury TC, Rahman SN *et al.* Anaritide in acute tubular necrosis. Auriculin Anaritide Acute Renal Failure Study Group. *N Engl J Med* 1997; **336**: 828–834.

[This multicenter, randomized, double-blind, placebo-controlled clinical trial of anaritide in 504 critically ill patients with acute tubular necrosis was similar to the dopamine study described above, but used a synthetic atrial natriuretic peptide, anaritide, to determine its influence in acute renal failure. The patients received a 24-hour intravenous infusion of either anaritide (0.2 µg/kg/min) or placebo. The primary end-point was dialysis-free survival for 21 days after treatment. Other end-points included the need for dialysis, changes in the serum creatinine concentration, and mortality. The rate of dialysis-free survival was 47% in the placebo group and 43% in the anaritide group ($p = 0.35$). In the prospectively defined subgroup of 120 patients with oliguria (urinary output, <400 ml per day), dialysis-free survival was 8% in the placebo group (5 of 60 patients) and 27% in the anaritide group (16 of 60 patients, $p = 0.008$). Anaritide-treated patients with oliguria who no longer had oliguria after treatment benefited the most. Conversely, among the 378 patients without oliguria, dialysis-free survival was 59% in the placebo group (116 of 195 patients) and 48% in the anaritide group (88 of 183 patients, $p = 0.03$). The study concluded that administration of anaritide did not improve the overall rate of dialysis-free survival in critically ill patients with acute tubular necrosis. However, anaritide may improve dialysis-free survival in patients with oliguria and may worsen it in patients without oliguria who have acute tubular necrosis. In many respects this study suffered the same failings (see below) as the dopamine study. This is a concern, as both dopamine and ANP may have a useful role in the management of some cases of impending acute renal failure.]

Key message

Low dose dopamine alone (2 µg/kg/min) does not improve renal function in patients with deteriorating renal function.

Why it's important and clinical relevance

This study is important because it highlights the fact that the use of dopamine as a magic bullet is unlikely to succeed. The use of dopamine over the last 30 years has been very much as an isolated agent, either as a prophylactic or as a treatment once renal function has deteriorated. In this study, it was shown to be unsuccessful as a treatment, its role in prophylaxis was not tested.

Strengths

This study was prospective, randomized, double-blind, controlled, and pragmatic. The study very much reflected the way in which dopamine is used in clinical practice. The use of multiple centers, clinicians, and end-points for use of renal replacement therapy placed an exacting test of the pharmacological properties of dopamine as a renal agent. When used in this manner, dopamine was shown to be ineffective. The study was designed to avoid the possible cardiovascular contribution that dopamine might provide to renal function by restricting dopamine to 2 µg/kg/min. This study therefore provides an answer to the question 'does dopamine have sufficient renal vascular or diuretic properties to avoid a rise in serum creatinine to beyond 250 µmol/L?' The answer is no.

Weaknesses

This study has tackled a very controversial aspect of renal management, and tried to isolate a specific activity of dopamine in a most complex group of patients with numerous confounders. The danger herein is that the message 'dopamine doesn't work' may not truly reflect dopamine in context.

The first weakness of this study was that it assumed volume status and mean blood pressures to be adequate for individual patients. Ideally, volume and pressure status should at least approximate premorbid values before starting a study that specifically seeks to isolate the renal effect of a drug. In fact, in this study, there were 195 patients in shock at the start of either the dopamine or placebo infusions, introducing the most important confounder for a renal study – inadequacy of resuscitation. In the presence of shock, dopamine is less likely to work, and even with similar distributions of the shocked patients, this study might be unwittingly under-powered. Right-sided cardiac filling pressures which were used as a measure of resuscitation have not been accepted as indicators of intravascular volume for a number of years, although in a pragmatic study, their use is understandable. While a large proportion of patients were shocked at the start of the test infusions, a further problem in the study was that there was no evidence to demonstrate that volume status or blood pressure were restored to appropriate levels for individual patients during the infusions.

This study also suffers in the choice of end-point. The primary end-point was defined as peak creatinine achieved during infusion. However, the infusion was stopped if dialysis was required. A quarter of the patients received dialysis, and since the criterion for this was not serum creatinine concentrations, the decision to start dialysis might have influenced distribution of the primary end-point. Unfortunately, in keeping with a pragmatic study, the precise criteria for dialysis were not defined. The study might have been stronger if the end-point was only the need for renal replacement therapy based on defined complications that, if uncontrolled do harm. For a pragmatic dopamine study, this might have been more clinically relevant. Related to this is the use of bicarbonate for acidosis, and potassium-reducing methods which might alter the need or timing of dialysis; neither were considered in the study, and could have altered the peak creatinine concentration reached by an individual. It is interesting to note that the need for dialysis was less in the dopamine group, although it did not reach statistical significance.

Further confounders in this study testing the specific renal activity of dopamine included the use of other diuretic agents such as furosemide. There is no mention of aminophylline, which inhibits tubuloglomerular feedback and is commonly used to stimulate a diuresis. These agents may not initially alter creatinine clearance, but through a brisk and sustained diuresis, might buy time for acid, volume, and potassium problems, and therefore influence the use of dialysis.

The concern in this seemingly clear-cut study is that 328 patients in a critical care cohort with multiple pathologies, numerous centers and clinicians, plus some concerns in methodology, may not have been enough. The authors might be right that 9000 patients could be required to separate the anticipated small effect of low-dose dopamine on intrinsic renal function. Unfortunately, it remains unclear whether better-defined criteria for volume and pressure status before and during the infusions, or a dialysis rather than creatinine end-point, might have influenced these results.

Dopamine, particularly in doses that augment cardiac output, should not be discarded yet on the basis of this study.

Appendix

[See also Introduction to Chapter]

Bartolomeo Eustachi (1520–1574) published in *Opuscula Anatomica* in 1564.

Lorenzo Bellini (1643–1704) in 1662 in his *Exercitatio Anatomica de Structura et Usu Renum*.

A translation of an extract from the 2nd edition of Bellini's work (1663) can be found in J.F. Fulton's *Selected Readings in the History of Physiology*, 2nd edn: 1966, pp. 350–352.

Marcello Malpighi (1628–1694) *De renibus* in the work *De viscerum structura exercitatio anatomica*. The work was reprinted, with translation, in *Annals of Medical History* 1925; **7**: 245–263.

In 1842 Sir William Bowman (1816–1892) published his observations on the circulation through the Malpighian bodies (*Phil Trans* 1842; **132**: 57–80). The paper was reprinted in *Med Classics* 1940; **5**: 258–259.

Professor Carl Friedrich Wilhelm Ludwig (1816–1895), *Beitrage zur Lehre vom Mechanismus der Harnsecretion*. Marburg: NG Elwert, 1843.

1857 Charles Edward Isaacs (1811–1860) (*Trans NY Acad Med* 1857; **1**: 437–456).

Claude Bernard (1813–1878) *Leçons sur les propriétés physiologiques et les alterations pathologiques des liquides de l'organisme*, published in 1859.

Nephrectomy: Charles L Stoddard (*Med Surg Reporter (Philad)* 1861; **7**: 126–127); Gustav von Simon (1824–1876) (*Dtsch Klin* 1870; **22**: 137–138); Karl Johann August Langenbuch (1846–1901) in 1877.

Nephrostomy: Joaquin Maria Albarran y Dominguez in 1896 (1860–1912) (*Rev Chir* 1896; **16**: 882–884).

Auto transplantation of kidneys in dogs 1902: Emerich Ullman (1861–1937) (*Wein Klin Wschr* 1902; **15**: 281–282).

Kidney transplant in animals: Alexis Carrel (*J Exp Med* 1908; **10**: 98–140).

Renin: Robert Adolf Armand Tigerstedt (1853–1923) and Per Gustaf Bergman (1874–1955) (*Scand Arch Physiol* 1898; **8**: 223–271).

Neurohypophysis and the kidney: Rudolf Magnus (1873–1927) and Ernest Henry Starling (1866–1927) (*J Physiol* 1901; **27**: 9–10).

Pyelography: Alexander Von Lichtenberg (1880–1949) (*Munch Med Wschr* 1906; **53**: 105–107).

Urine pH: John Beresford Leathes (1864–1956) (*BMJ* 1919; **2**: 165–167).

Urea concentration test: Hugh MacLean (1879–1957) and Owen Lambert Vaughan de Wesselow (1883–1959) (*Br J Exp Pathol* 1920; **1**: 53–65).

Urea clearance tests: Eggert Hugo Heiberg Möller, in 1928.

Creatinine clearance: Poul Brandt Rehberg (1895–1985) (*Biochem J* 1926; **20**: 447–482).

GFR and tubular resorption: 1924 Joseph Treloar Wearn (1893–1984) and Alfred Newton Richards (1876–1966) (*Am J Physiol* 1924; **71**: 209–227).

Effect of vasopressin on the kidney: Starling and Ernest Basil Verney (1894–1967) (*Proc R Soc B* 1924; **25**: 321–363).

Renal tubules of a vertebrate could secrete foreign substances: Eli Kennerly Marshall Jr (1889–1966) (*Bull Johns Hopk Hosp Baltimore* 1929; **45**: 95–101).

Fanconi (1892–1979) (*Jb Kinderheilk* 1931; **133**: 257–300).

Adrenaline and the kidney: Alfred Newton Richards (1876–1966) and Carl Frederic Schmidt (1893–1988) (*Am J Physiol* 1924; **71**: 178–208).

Estimates of afferent arteriole and glomerular capillary pressures in the frog kidney: Joseph Marchant Hayman (*Am J Physiol* 1927; **79**: 389–409).

Artificial kidney: WJ Kolff (*Ned Tijdschr Geneesk* 1943; **87**: 1684–1692; *Acta Med Scand* 1944; **117**: 121–134).

Dialysis in uraemia: 1956, Kolff and Watschinger (*J Lab Clin Med* 1956; **47**: 969–977).

Indwelling Teflon silastic arteriovenous shunt: W.E. Quinton, D. Dillard and B.H. Scribner (*Trans Am Soc Artif Intern Organs* 1960; **6**: 104–113).

Peritoneal dialysis: 1923, G. Ganter (*Munch Med Wschr* 1923; **70**: 1478–1480).

Peritoneal dialysis in acute renal failure: Jacob Fine with H.A. Frank and A.M. Seligman (*Ann Surg* 1946; **124**: 857–878).

Renal transplant: (*JAMA* 1950; **144**: 844–845). 9 cases. David Milford Hume (1917–1973) with J.P. Merrill, B.F. Miller and G.W. Thorn (*J Clin Invest* 1955; **34**: 327–382).

First renal transplant between patients: J.P. Merrill with J.E. Murray, J.H. Harrison and W.R. Guild (*JAMA* 1956; **160**: 277–282).

The liver in critical illness

Felicity Hawker

Introduction

The liver is in some ways the forgotten organ in intensive care practice. Very many more laboratory and clinical studies have investigated the role, function, and support of the lung, heart, brain, and kidney in critical illness than have studied the liver. Nevertheless, in the time of the Greek scholars, there was already acknowledgement of the role of the liver in non-hepatic diseases such as systemic sepsis, and an understanding that such involvement confers a poorer prognosis – hence the inclusion of the wisdom of Hippocrates in this compilation of classic papers. In the review article by Matuschak and Rinaldo, the reasons why liver dysfunction is associated with a poorer outcome in critical illness are explored, and the concept of the liver being a ‘driving force’ in multiple organ dysfunction is developed. In addition, jaundice without significant liver dysfunction is associated with left ventricular dysfunction, at least in the dog model developed by Professor Otto Better and his colleagues in Israel. This observation is relevant to the progressive resistance to inotropic and vasopressor agents in jaundiced critically ill patients.

One of the most devastating insults that can occur in critical illness is acute liver ischemia, resulting in the clinical syndrome of ischemic or hypoxic hepatitis. Although relatively common, this syndrome has been difficult to study prospectively. Consequently, the paper by Jean Henrion from Belgium offers new insights into the hemodynamic associations of ischemic hepatitis, which is, of course, a circulatory disease, not a liver disease.

Commonly used ‘liver function tests’ assess damage to the liver rather than its function. An understanding of the complex relationship between critical illness and liver dysfunction has been hampered by the absence of a simple test that assesses at least one of the many functions of the liver. The MEGX test, developed by Oellerich and co-workers in Germany, allows dynamic assessment of liver function, and may prove useful in the evaluation of therapies to support liver function in critical illness.

The complex issues involved in the management of patients with acute liver failure exemplify the many important functions of the healthy liver. With the advent of liver transplantation as the principle treatment for patients with fulminant hepatic failure, these patients are almost always managed in ICUs servicing liver transplant units. Consequently, it is extremely important that intensive care practitioners in non-liver units understand the need to refer patients to transplant units, as well as the role of transplantation in acute liver failure and its indications. The seminal paper by O’Grady and the group from King’s College Hospital, London, develops criteria for liver transplantation in acute liver failure. That a successful outcome is possible after emergency liver transplantation for acute liver failure is shown in the early series of cases reported from the French group from Clichy and Villejuif. When transplantation is not indicated, or while awaiting a donor, the principal treatment is supportive. The paper by Harrison and co-workers, again from the King’s Liver Unit, investigates the effects of n-acetylcysteine in patients with acute liver failure, and the findings of this study have resulted in widespread use of this agent in this setting. Currently, there is still no safe, effective means of artificial liver support for patients awaiting transplantation or liver regeneration. The case report from Saunders and co-workers from Cape Town, South Africa, describes an early attempt to develop such support.

Finally, patients with cirrhosis and other forms of chronic liver disease present different management challenges for the intensive care specialist. The randomized controlled trial from

the Barcelona group shows that in patients with spontaneous bacterial peritonitis and cirrhosis, the outcome is improved by infusing albumin in addition to antibiotic therapy.

There are many classic papers that have not been included in this small selection. The majority of papers have been chosen for the underlying ideas and variety rather than for scientific rigor. They are aimed at clinical intensive care specialists with enquiring minds who work in general intensive care units, rather than experts in liver units or intensive care units servicing liver transplant units. I have found the liver a fascinating organ to study. I trust this selection of papers will likewise stimulate your interest.

Title

Whenever in fevers jaundice supervenes before seven days, this is bad

Author

Hippocrates

Reference

Aphorism IV 60. In: *Stephanus of Athens. Commentary on Hippocrates' Aphorisms*, Sections III–IV. Text and translation by Westerink LG. Berlin: Akademie Verlag, 1992

Abstract

Not applicable

Summary

Hippocrates examines a number of questions with respect to jaundice associated with systemic infection. He concludes that jaundice is a result of impairment of the separative faculty of the liver; that is, impairment of its ability to purify all the humors. He further states that this may occur as a result of obstruction of the biliary vessels or of seething inflammations, in which case the blood is distributed through the whole body with a strong admixture of bile.

Citation count Not applicable

Related references

1. te Boekhorst T, Urlus M, Doesburg W, Yap SH, Goris RJ. Etiologic factors of jaundice in severely ill patients. A retrospective study in patients admitted to an intensive care unit with severe trauma or with septic intra-abdominal complications following surgery and without evidence of bile duct obstruction. *J Hepatol* 1988; **7**: 111–117.
2. Gimson AES. Hepatic dysfunction during bacterial sepsis. *Intensive Care Med* 1987; **13**: 162–166.
3. Zimmerman H, Fang M, Utli R, Seeff L, Hoofnagle J. Jaundice due to bacterial infection. *Gastroenterology* 1979; **77**: 362–374.

Key message

Jaundice may develop in primarily non-hepatic systemic illnesses, particularly infection. In this setting, jaundiced patients have a poorer outcome.

Why it's important

This may be the first description of jaundice associated with sepsis, and its adverse effect on outcome.

Strengths

Originality.

Weaknesses

Not evidence-based!!!

Relevance

A reminder that clinical experience and wisdom have been, and always will be, key factors in the practice of intensive care medicine

Title***Organ interactions in the adult respiratory distress syndrome during sepsis: role of the liver in host defence***

Author

Matuschak GM, Rinaldo JE

Reference*Chest* 1988; **94**: 400–406

Abstract

Not available

Summary

This review article explores the role of the liver in the pathogenesis of the adult respiratory distress syndrome (ARDS) and progressive multiple systems organ failure. It is argued that the normal liver plays a pivotal role in aspects of host defence that are crucial to the protection of the lung and other organs in systemic sepsis. The authors note that the fixed hepatic macrophages, or Kupffer cells, constitute nearly 90% of the body's reticuloendothelial cell mass. They further note that these cells are the major mechanism for clearance of systemic endotoxin and bacterial products. The strategic location of the liver, immediately downstream from the large gastrointestinal reservoir of bacteria and bacterial products, normally constitutes an effective first line in host control of systemic endotoxemia and bacteremia.

However, the balance may be altered by an excess load of bacterial products in the gut, mesenteric or hepatic ischemia, and Kupffer cell dysfunction, so that the phagocytic capacity of Kupffer cells is exceeded, resulting in systemic spread of bacterial products. Moreover, the authors describe the activation of Kupffer cells by the phagocytic burst, resulting in the release of an array of inflammatory mediators that are 'exported' systemically, and result in acute pathophysiological reactions in distant organs. These inflammatory mediators also have effects on adjoining hepatic parenchymal cells. Evidence is presented that the resulting hepatocyte damage may result in decreased clearance of some of these mediators, resulting in heightened and prolonged effects, and consequent amplification of multiple organ damage. Furthermore, these inflammatory mediators – particularly interleukin-1 – induce changes in hepatic protein synthesis, characterized principally by the 'acute phase response'.

Thus, this review acknowledges the role of the liver in host defence but also proposes ways in which liver dysfunction might fuel multiple organ dysfunction – particularly ARDS.

Citation count

95

Related references

1. Jarrar D, Chaudry IH, Wang P. Organ dysfunction following hemorrhage and sepsis: mechanisms and therapeutic approaches (Review). *Int J Mol Med* 1999; **4**: 575–583.
2. Carrico CJ, Meakins JL, Marshall JC, Fry D, Maier RV. Multiple-Organ-Failure Syndrome: the gastrointestinal tract – the motor of MOF. *Arch Surg* 1986; **121**: 197–201.
3. Marshall JC, Lee C, Meakins JL, Michel RP, Christou NV. Kupffer cell modulation of the systemic immune response. *Arch Surg* 1987; **122**: 191–196.

Key message

The liver plays a major role in host defence, but also has the capacity to augment the host response, with consequent adverse effects on other organs in some circumstances. This has led to the concept of the liver as 'the motor of multiple organ failure'.

Why it's important

This review was among the first to provide a plausible concept of organ system interactions that may result in ARDS and multiple organ failure in sepsis. Although some of the detail has been refined, the general principles remain accepted 15 years later.

Strengths

This paper synthesizes experimental findings from a number of disciplines – intensive care medicine, hepatology, immunology, and thoracic medicine – to arrive at a concept that was new at the time of publication, and which continues to be supported in the main by more recent evidence.

Weaknesses

This paper is not a systematic review.

Relevance

The general concepts in this review remain valid, and have led to a more concentrated focus on the gut and liver in the critically ill patient, both experimentally and in the clinical setting. Although there have been major advances in understanding of relevant factors such as splanchnic blood flow, no 'liver-orientated therapy' has yet been shown to be of value in ARDS and multiple organ failure, and the treatment of liver dysfunction remains supportive.

Title

The “jaundiced heart”: a possible explanation for postoperative shock in obstructive jaundice

Author

Green J, Beyar R, Sideman S, Mordechovitz D, Better O

Reference

Surgery 1986; **100**: 14–19

Abstract

Patients with obstructive jaundice are susceptible to postoperative shock and kidney failure. The cause of these potentially fatal complications has not been fully clarified. The present study was designed to assess the role of myocardial dysfunction in the hemodynamic disturbance of obstructive jaundice. We studied the effect of isolated cholemia on left ventricular performance in five conscious dogs, before and 2 weeks after choledochocaval anastomosis, by using measurements of systolic time intervals (STIs) and maximal dp/dt. Mean left ventricular ejection time (LVET) decreased after cholemia from 159 \pm 2.8 msec to 139 \pm 2.6 msec ($p < 0.005$), while mean preejection period (PEP) and mean PEP/LVET were increased from 41 \pm 8.5 msec to 87 \pm 14 msec ($p < 0.05$) and from 0.39 \pm 0.06 to 0.62 \pm 0.1 ($p < 0.01$), respectively. During cholemia, STIs were unchanged after intravenous administration of ouabain, whereas in the control period, there was shortening of mean PEP from 71 \pm 8.8 msec to 58 \pm 7.6 msec ($p < 0.05$), and of Q-S2 from 257 \pm 12 msec to 235 \pm 14 msec ($p < 0.005$) in response to ouabain. Maximal dp/dt decreased after choledochocaval anastomosis from 4543 \pm 593 mmHg/sec to 3666 \pm 648 mmHg/sec ($p < 0.025$). We conclude that cholemia in the dog is clearly associated with impaired left ventricular performance. The present data also support a previously published in vitro study from our laboratory showing that cholemia blunts the myocardial contractile response to sympathomimetic agents. The cardiodepressor effect of cholemia may explain the increased tendency of patients with obstructive jaundice to postoperative shock and renal failure.

Summary

The effect of deep jaundice on left ventricular function was studied in five dogs. Each dog was studied before and 2 weeks after choledochocaval anastomosis (CDCA), thus each dog served as its own control. CDCA results in severe jaundice with minimal liver damage. Mean arterial blood pressure, end-diastolic left ventricular pressure, and maximal rate of increase in left ventricular pressure (dp/dt) were obtained by retrograde catheterization of the aorta and left ventricle. Systolic time intervals (pre-ejection period (PEP) and left ventricular ejection time (LVET)) were measured with simultaneous ECG and aortic pulse tracings. Systolic time intervals were measured before and after intravenous injection of ouabain.

The findings revealed that deep jaundice was associated with impaired left ventricular performance. There was a decrease in dp/dt without changes to arterial pressure, heart rate, or preload. Moreover, there was an associated increase in mean left ventricular PEP, and a decrease in LVET when compared with predicted values. Although administration of ouabain in normal dogs (i.e. pre-CDCA) was associated with decreased PEP, no effect was observed in deeply jaundiced animals.

Citation count

48

Related references

1. Wakim KG, Essex HE, Mann FC. The effects of whole bile and bile salts on the perfused heart. *Am Heart J* 1939; **18**: 171–175.
2. Bashour TT, Antonini C, Fisher J. Severe sinus node dysfunction in obstructive jaundice. *Ann Intern Med* 1985; **103**: 384–385.
3. Binah O, Bomzon A, Blendis I, Mordohovich D, Better O. Obstructive jaundice blunts myocardial contractile response to isoprenaline in the dog: a clue to the susceptibility of jaundiced patients to shock? *Clin Sci* 1985; **69**: 647–653.

Key message

Deep jaundice may have hemodynamic consequences even when liver function is relatively intact. It is associated with impaired left ventricular performance that is refractory to cardiac glycosides in this animal model.

Why it's important

The hemodynamic manifestations of advanced liver failure with jaundice are well described, and are basically a 'high output-low resistance' state. This paper suggests that jaundice has its own effects on cardiac function independent of liver failure.

Strengths

The authors are clearly original thinkers who have devised an animal model to shed light on a clinical problem. The model is relevant to patients with jaundice associated with multiple organ failure, as well as obstructive jaundice

Weaknesses

This is a small animal study. The methods of assessment of left ventricular function are probably valid, but are not conventional.

Relevance

Patients with multiple organ failure are frequently jaundiced, and in this setting, plasma bilirubin concentrations may be grossly elevated. Such patients often also have severe hemodynamic compromise that can be refractory to inotropic agents. Although this paper does not offer a solution to this problem, it does propose a plausible mechanism.

Title

Hypoxic hepatitis in patients with cardiac failure: incidence in a coronary care unit and measurement of hepatic blood flow

Author

Henrion J, Descamps O, Luwaert R, Schapira M, Parfonry A, Heller F

Reference

J Hepatol 1994; **21**: 696–703

Abstract

The incidence of hypoxic hepatitis was prospectively studied for 1 year in a group of high-risk patients suffering from low cardiac output in a coronary care unit. Hypoxic hepatitis, defined as an increase in serum aminotransferase activity of at least 20 times the upper limit of normal without any other cause for hepatic necrosis, was observed in 20 patients. This represents 2.6% of the 766 patients admitted to the unit during this period, and 21.9% of the 91 patients suffering from low cardiac output. Clinical, biological, and hemodynamic data were compared between 20 patients with low cardiac output and hypoxic hepatitis, and 48 patients with low cardiac output but without hypoxic hepatitis who survived more than 24 hour. In these two groups of patients, hepatic blood flow was measured by galactose clearance at low concentration. Patients with hypoxic hepatitis exhibited a higher central venous pressure (90% versus 38%, $p < 0.001$), as well as a lower hepatic blood flow (867 \pm 377 ml/min versus 1429 \pm 644 ml/min, $p = 0.001$). In conclusion, although it is considered a rare hepatic disorder, hypoxic hepatitis is frequent in patients with low cardiac output admitted to the coronary care unit, and is associated with a decrease in hepatic blood flow, and passive hepatic venous congestion.

Summary

Over a 1-year period in a Belgian coronary care unit, 91 patients were identified as having a low cardiac output using clinical criteria. Hypoxic (ischemic) hepatitis (HH) was said to be present if there was a clinical setting of circulatory failure, a sharp but transient increase in serum aminotransferase activities of at least 20 times the upper limit of normal, and after exclusion of other causes of hepatic necrosis. Of the 91 patients, 20 developed HH (2.6% of admissions to the coronary care unit; 21.9% of patients with low cardiac output), 48 did not develop HH, and 23 died within 24 hours. Hepatic blood flow was measured in the 20 patients with HH, and in 41 of the 48 surviving patients without HH, using the method of galactose clearance at low concentrations. When compared with patients who did not develop HH, patients with HH had lower hepatic blood flow (867 \pm 377 ml/min vs 1429 \pm 644 ml/min), higher central venous pressure (22.5 cmH₂O vs 14 cmH₂O), and a trend toward lower cardiac output (3.4 L/min vs 4.4 L/min). Interestingly, only approximately 50% of patients in each group had a systolic arterial pressure below 90 mmHg. The overall mortality was high – 55% in the HH group and 46% in the group without HH.

Citation count

26

Related references

1. Gibson P, Dudley F. Ischemic hepatitis: clinical features, diagnosis and prognosis. *Aust NZ J Med* 1984; **14**: 822–825.

2. Fuchs S, Bogomolski-Yahalom V, Paltiel O, Ackerman Z. Ischemic hepatitis: clinical and laboratory observations of 34 patients. *J Clin Gastroenterol* 1998; **26**: 183–186.
3. Garland J, Werlin S, Rice T. Ischemic hepatitis in children: diagnosis and clinical course. *Crit Care Med* 1988; **16**: 1209–1212.

Key message

The findings of this study show that ischemic hepatitis is common in environments where there are patients with low cardiac output states, such as Coronary Care Units and Intensive Care Units. The classic hemodynamic pattern is low cardiac output (resulting in reduced hepatic blood flow), and high right atrial pressure. Hypotension is not a prerequisite. The mortality rate is >50%

Why it's important

This is the first prospective study to determine the incidence of ischemic hepatitis in patients with severe cardiac disease and low cardiac output. It is also by far the most comprehensive study of hemodynamic measurements in patients with ischemic hepatitis, and the only one to measure liver blood flow.

Strengths

This is a large, prospective, observational study of 766 patients admitted to a single intensive care unit over a 1-year period.

Weaknesses

Exclusion of the 23 patients who died within 24 hours of the episode of low cardiac output, before measurements of hepatic blood flow had been made, may have altered the findings, particularly regarding the incidence of ischemic hepatitis. The validity of the hepatic blood flow measurements themselves are open to some dispute – firstly because of the use of galactose clearance rather than indocyanine green clearance, and secondly because they were performed subsequent to the episode of low cardiac output, and therefore may not reflect the hemodynamic state at that time.

Relevance

Ischemic hepatitis occurs in up to 5% of admissions to Intensive Care Units and Coronary Care Units, and is consequently more common than a number of other conditions that have attracted massive research interest. This paper describes the clinical setting, hemodynamic characteristics, and outcome of ischemic hepatitis, and consequently makes a major contribution to the body of knowledge on the subject. Ischemic hepatitis is not a rare hepatic disorder, but rather it is a circulatory disorder, and therefore of great relevance to intensive care medicine.

Title

Monoethylglycinexylidide formation kinetics: a novel approach to assessment of liver function

Author

Oellerich M, Raude E, Burdelski M, Schulz M, Schmidt FW, Ringe B, Lamesch P, Pichlmayr R, Raith H, Scheruhn M, Wrenger M, Wittekind C

Reference

J Clin Chem Clin Biochem 1987; **25**: 845–853

Abstract

A novel quantitative liver function test is described which is based on monoethylglycinexylidide (MEGX) formation after lidocaine bolus injection. Following the administration of small single doses of lidocaine hydrochloride (1 mg/kg), monoethylglycinexylidide serum concentration-time curves were determined by a novel, highly sensitive fluorescence polarization immunoassay (FPIA) in healthy volunteers, liver donors, and patients with liver cirrhosis. The FPIA allowed rapid and reliable monoethylglycinexylidide determinations in serum and urine (between-days coefficient of variation: < 10.3%, recovery: 80–113%). Monoethylglycinexylidide concentrations measured by FPIA in 32 serum samples from patients correlated well with those determined by HPLC. The monoethylglycinexylidide concentration in serum determined 15 minute after a lidocaine bolus injection proved to be a highly sensitive and specific indicator of hepatic dysfunction. Average monoethylglycinexylidide concentrations in serum obtained 15 minute after lidocaine injection were substantially lower in patients with liver cirrhosis than in healthy volunteers. The average monoethylglycinexylidide concentrations in serum were also substantially lower in liver donors with ballooning or fatty changes of hepatocytes than in donors without relevant alterations of liver histology. By means of monoethylglycinexylidide formation in the liver donors, primary function of the transplanted liver was correctly predicted in 32/37 cases, and initial non-function in 4/6 cases.

Summary

Monoethylglycinexylidide (MEGX) is the first metabolite of lignocaine formed by oxidative de-ethylation by the hepatic cytochrome P-450 system. In this study, the appearance of MEGX measured by a fluorescence polarization immunoassay after a test dose of intravenous lignocaine was investigated as a liver function test. The findings showed that there was a satisfactory correlation between the measurement of MEGX by the novel fluorescence polarization immunoassay and by high performance liquid chromatography. The formation and elimination kinetics of MEGX were investigated for healthy volunteers, patients with histologically confirmed liver cirrhosis, and liver donors after a single intravenous bolus injection of lignocaine (1 mg/kg). In healthy volunteers, the peak MEGX concentration occurred 15 minutes after the bolus of lignocaine, whereas in patients with cirrhosis, its rate of formation was markedly decreased, and maximum concentrations were observed at about 4 hours. In liver donors the 15-minute MEGX concentration was lower in donors, with altered liver histology than in those with normal histology. Patients with cirrhosis had the lowest 15-minute MEGX concentration of all the groups.

Citation count

194

Related references

1. Oellerich M, Armstrong VW. The MEGX test: a tool for the real-time assessment of hepatic function. *Ther Drug Monit* 2001; **23**: 81–92.
2. Maynard ND, Bihari DJ, Dalton RN *et al*. Liver function and splanchnic ischemia in critically ill patients. *Chest* 1997; **111**: 180–187.
3. Schroter J, Wandel C, Bohrer H *et al*. Lignocaine metabolite formation: an indicator for liver dysfunction and predictor of survival in surgical intensive care patients. *Anesthesia* 1995; **50**: 850–854.

Key message

Conventional 'liver function tests' measure liver damage rather than liver function. The MEGX test assesses the liver's capacity to metabolize drugs (in this case lignocaine), and thus is a true 'liver function test'. The data presented in this study suggest that the 15-minute MEGX concentration varies with the adequacy of liver function.

Why it's important

This paper is the first to describe and assess the formation of MEGX after a standard dose of lignocaine as a dynamic liver function test.

Strengths

Novel approach.

Weaknesses

The test is not well validated in this report.

Relevance

Because of its ease of use and rapid turnaround, the MEGX test has found widespread application for the real-time assessment of hepatic function. In liver transplantation, the MEGX test has found a place in selection of transplant candidates, and in monitoring of liver recipients early after transplantation. In intensive care patients, a rapid decrease in MEGX test values is associated with increased risk of developing multiple organ failure, and a poor outcome, and consequently may have a role in investigation of the role of the liver in the multiple organ failure syndrome.

Title

Early indicators of prognosis in fulminant hepatic failure

Author

O'Grady J, Alexander G, Hayllar K, Williams R

Reference

Gastroenterology 1989; **97**: 439–445

Abstract

The successful use of orthotopic liver transplantation in fulminant hepatic failure has created a need for early prognostic indicators to select the patients most likely to benefit at a time when liver transplantation is still feasible. Univariate and multivariate analysis was performed on 588 patients with acute liver failure managed medically during 1973–1985, to identify the factors most likely to indicate a poor prognosis. In acetaminophen-induced fulminant hepatic failure, survival correlated with arterial blood pH, peak prothrombin time, and serum creatinine – a pH < 7.30, prothrombin time > 100 seconds, and creatinine > 300 µmol/L indicated a poor prognosis. In patients with viral hepatitis and drug reactions, three static variables [etiology (non A, non B hepatitis or drug reactions), age < 11 and > 40 year, duration of jaundice before the onset of encephalopathy > 7 days], and two dynamic variables (serum bilirubin > 300 µmol/L, and prothrombin time > 50 seconds) indicated a poor prognosis. The value of these indicators in determining outcome was tested retrospectively in a further 175 patients admitted during 1986–1987, leading to the construction of models for the selection of patients for liver transplantation.

Summary

The records of 588 patients with fulminant hepatic failure (FHF) and grade III or IV encephalopathy admitted to King's College Hospital, London, between 1973 and 1985, were scrutinized to identify simple parameters that might prove to be prognostic indicators. These parameters were examined by univariate and multivariate analysis to determine the factors most likely to be associated with poor prognosis. The analysis was performed in two groups, paracetamol-induced and non-paracetamol-induced, because of the higher incidence of renal failure and metabolic acidosis in the former group.

The prognostic indicators so determined were then examined retrospectively, in a second group of 175 patients with FHF admitted during 1986–1987, to determine their sensitivity and specificity in prediction of a fatal outcome. Models were then constructed for selection of patients for liver transplantation on the basis of an extremely poor prognosis with medical management.

The criteria adopted for paracetamol-induced FHF were pH < 7.30 (irrespective of grade of encephalopathy), or prothrombin time > 100 seconds and serum creatinine > 300 µmol/L in patients with grade III or IV encephalopathy.

For FHF unrelated to paracetamol, the criteria determined were prothrombin time > 100 seconds (irrespective of grade of encephalopathy), or any three of (irrespective of grade of encephalopathy): age < 10 or > 40 years, etiology (non-A, non-B hepatitis or idiosyncratic drug reactions), duration of jaundice before onset of encephalopathy > 7 days, prothrombin time > 50 seconds, and serum bilirubin > 300 µmol/L.

Citation count

725

Related references

1. Tygstrup N, Ranek L. Assessment of prognosis in fulminant hepatic failure. *Semin Liver Dis* 1986; **6**: 129–137.
2. Bernuau J, Goudeau A, Poynard T *et al*. Multivariate analysis of prognostic factors in fulminant hepatitis B. *Hepatology* 1986; **6**: 648–651.
3. Anand AC, Nightingale P, Neuberger JM. Early indicators of prognosis in fulminant hepatic failure: and assessment of the King's criteria. *J Hepatol* 1997; **26**: 62–68.

Key message

This study has developed criteria that predict death in patients with FHF who are managed medically. In the era of liver transplantation, these criteria are also used to select patients for liver transplantation. All patients with FHF should be discussed with a transplant unit. Patients who meet these criteria should be transplanted.

Why it's important

This paper has changed practice. It allows decisions to be made about transplantation in FHF so that unnecessary transplantation can be minimized. Because the criteria involve simple, easy to apply parameters that are readily available, the algorithm also permits decisions to transplant to be taken early, maximizing the period of time available to find a suitable donor, and allowing transplantation to be undertaken before the development of cerebral edema.

Strengths

This study is based on the largest number of patients in a single unit ever reported.

Weaknesses

Data were collected over a period of 13 years, and it is possible that one or more aspects of management may have changed in that time, and may independently affect outcome.

Relevance

Various models have been used to predict outcome in FHF, but the 'King's criteria' identified in this study are the most widely used. These criteria are based on the study of a huge number of patients treated medically, and, because so many patients are now transplanted, it is extremely unlikely that the study could ever be repeated. Consequently, the criteria identified in this paper are likely to be used widely to select transplant candidates for the foreseeable future.

Title

Emergency liver transplantation for fulminant hepatitis

Author

Bismuth H, Samuel D, Gugenheim J, Castaing D, Bernuau J, Rueff B, Benhamou JP

Reference

Ann Intern Med 1987; **107**: 337–341

Abstract

Orthotopic liver transplantation was done in 17 patients with fulminant hepatitis. The cause of the liver disease was infection with hepatitis B virus, or co-infection with hepatitis B virus and hepatitis D virus, or infection with hepatitis A virus in 6 patients; drug hepatotoxicity in 5; and indeterminate in 6. Grafts from incompatible blood groups, steatotic grafts, or reduced-size grafts were used in 5, 4, and 4 patients, respectively. Of the 17 patients, 5 died: 2 of early liver failure due to the poor quality of the graft, 1 presumably of accidentally transmitted acute infection with the human immunodeficiency virus, and 2 of decerebration occurring during or immediately after surgery. The 12 other patients were alive 2 to 15 months after transplantation.

Summary

This paper reports the clinical details and outcome of 17 patients with acute liver failure who underwent orthotopic liver transplantation in the mid-1980s, in the Hopital Paul-Brousse, Villejuif, and the Hopital Beaujon, Clichy, France. Six patients had documented viral hepatitis, five had drug hepatotoxicity, and the cause was undetermined in the remaining six. Despite compromises necessitated by emergency transplantation (ABO and size incompatibility, and steatotic grafts), 12 patients survived. Deaths were due to cerebral edema (2), early graft failure (2), and graft-transmitted infection.

Citation count

237

Related references

1. Bismuth H, Samuel D, Castaing D, Williams R, Pereira SP. Liver transplantation in Europe for patients with acute liver failure. *Semin Liver Dis* 1996; **16**: 415–425.
2. Sheil AGR, McCaughan GW, Isai H, Hawker F, Thompson JF, Dorney SFA. Acute and subfulminant liver failure: the role of liver transplantation. *Med J Aust* 1991; **154**: 724–728.
3. Peleman RR, Gavaler JS, Van Thiel D *et al*. Orthotopic liver transplantation for acute and subacute hepatic failure in adults. *Hepatology* 1987; **3**: 484–489.

Key message

Liver transplantation can be a successful treatment for acute liver failure, and, overall, the outcome with transplantation is better than with supportive medical management alone.

Why it's important

This paper was the first large case study to document the feasibility and success of liver transplantation for acute liver failure.

Strengths

This is a succinct review of 17 patients with acute liver failure who underwent liver transplantation, with appropriate demographic, etiological, clinical, and outcome information that remains relevant many years later.

Weaknesses

No case control data are reported. Although it is stated that transplantation was undertaken for a rapidly deteriorating neurological condition and severe coagulation disorders, the outcome of patients who did not meet these criteria, or who met the criteria and could not be transplanted, is not reported. Hence, although this paper describes the feasibility of liver transplantation in this population, it does not assess the value.

Relevance

Liver transplantation, as described in this case series, remains the best chance of survival for the majority of patients with acute liver failure. Although criteria for transplantation, and aspects of the surgical technique and postoperative immunosuppression have developed over the intervening years, orthotopic liver transplantation has not been superseded, and should be considered as an option in all patients with acute liver failure.

Title

Improvement by acetylcysteine of hemodynamics and oxygen transport in fulminant hepatic failure

Author

Harrison PM, Wendon JA, Gimson AES, Alexander GJM, Williams R

Reference

N Engl J Med 1991; **324**: 1852–1857

Abstract

BACKGROUND. When administered early after an overdose of acetaminophen, intravenous acetylcysteine prevents hepatic necrosis by replenishing reduced stores of glutathione. How acetylcysteine improves the survival of patients with established liver damage induced by acetaminophen, however, is unknown. This study was undertaken to determine whether the beneficial effect of acetylcysteine under such circumstances could be due to enhancement of oxygen delivery and consumption. **METHODS.** We studied the effect of acetylcysteine on systemic hemodynamics and oxygen transport in 12 patients with acetaminophen-induced fulminant hepatic failure, and 8 patients with acute liver failure from other causes. The acetylcysteine was given in a dose of 150 mg/kg in 250 ml of 5% dextrose over a period of 15 minutes, and then in a dose of 50 mg/kg in 500 ml of 5% dextrose over a period of 4 hours; measurements were made before treatment began, and after 30 minutes of the regimen. **RESULTS.** In the patients with acetaminophen-induced liver failure, the infusion of acetylcysteine resulted in an increase in mean oxygen delivery from 856 to 975 ml/min/m² ($p = 0.0036$), due to an increase in the cardiac index from 5.6 to 6.7 mm/m² ($p = 0.0021$). Mean arterial pressure rose from 88 to 95 mmHg ($p = 0.0054$), despite a decrease in systemic vascular resistance from 1296 to 1113 dyn.sec.cm⁻⁵ per square meter ($p = 0.027$). There was an increase in oxygen consumption from 127 to 184 ml/min/m² ($p = 0.0007$) associated with an increase in the oxygen-extraction ratio from 16 to 21 percent ($p = 0.022$). The effects in the patients with acute liver failure from other causes were similar. **CONCLUSIONS.** The increase in oxygen delivery and consumption in response to acetylcysteine may account for its beneficial effect on survival in patients with fulminant hepatic failure induced by acetaminophen.

Summary

The effects of intravenous n-acetylcysteine on systemic hemodynamics and oxygen transport were studied in 12 patients with paracetamol-induced acute liver failure, and eight patients with acute liver failure from other causes. Measurements were made before a bolus dose of 150 mg/kg of n-acetylcysteine given over 15 minutes, and 30 minutes after commencement of an infusion of 50 mg/kg of n-acetylcysteine given over 4 hours.

The findings were that in patients with paracetamol-induced acute liver failure, infusion of n-acetylcysteine resulted in an increase in mean oxygen delivery from 856 to 975 ml/min/m², resulting mainly from an increase in the mean cardiac index by approximately 20% (5.6 to 6.7 L/min/m²). Mean arterial pressure increased from 88 to 95 mmHg despite a decrease in the mean systemic vascular resistance from 1296 to 1113 dyn/sec/cm⁻⁵. In patients with acute liver failure from other causes, the effects of n-acetylcysteine were similar but less marked, and there were significant changes (increases) only for oxygen consumption and oxygen extraction ratio.

Each patient had similar measurements performed before and during an infusion of prostacyclin at a rate of 5 ng/kg, and again when n-acetylcysteine and prostacyclin were infused simultaneously. The effects of prostacyclin were similar to those of n-acetylcysteine, but there was a decrease in mean arterial pressure rather than an increase, and a much smaller increase in oxygen extraction.

Four patients with acute liver failure secondary to paracetamol were studied after recovery. In this group, n-acetylcysteine had no effect on any hemodynamic or oxygen transport variable. However, with infusion of prostacyclin, there was an increase in cardiac index, decrease in systemic vascular resistance, and increased oxygen delivery without an increase in consumption.

Citation count 255

Related references

1. Walsh TS, Hopton P, Philips BJ, Mackenzie SJ, Lee A. The effect of n-acetylcysteine on oxygen transport and uptake in patients with fulminant hepatic failure. *Hepatology* 1998; **27**: 1332–1340.
2. Harrison PM, Keays R, Bray GP, Alexander GJ, Williams R. Improved outcome of paracetamol-induced fulminant hepatic failure by late administration of acetylcysteine. *Lancet* 1990; **335**: 1572–1573.
3. Rank R, Michel C, Haertel C *et al*. N-acetylcysteine increases liver blood flow and improves liver function in septic shock patients: results of a prospective, randomised, double-blind study. *Crit Care Med* 2000; **28**: 3799–3807.

Key message

There is a characteristic high output-low resistance hemodynamic state in fulminant hepatic failure that may be associated with covert tissue hypoxia. Intravenous infusion of n-acetylcysteine was associated with an increase in oxygen delivery and consumption, and also in tissue oxygen extraction in patients with fulminant hepatic failure. It is postulated that this may account for the beneficial effect of n-acetylcysteine on survival in patients with acute liver failure caused by paracetamol, and further, may be of benefit in patients with multiple organ failure from other causes, such as sepsis.

Why it's important

This study is the justification for the widespread use of n-acetylcysteine in patients with acute liver failure, and it has also provoked investigation of possible clinical benefits in other conditions, such as septic shock.

Strengths

This is a comprehensive clinical study of a relatively homogeneous group of patients.

Weaknesses

Because the Fick method was used to calculate oxygen consumption from the cardiac output and the arteriovenous oxygen content difference, it is possible that an artifactual relationship between oxygen delivery and consumption was shown because of mathematical coupling. It is now generally accepted that oxygen delivery and consumption should be determined independently.

Relevance

Although undoubtedly a classic study, the findings presented in this paper have not been confirmed in a similar more recent study (see Related reference no. 1). In the latter study, oxygen consumption was measured independently of oxygen delivery, using a method based on respiratory gas analysis, and patients were studied over a longer period. Nevertheless, the paper under review has been responsible in part for a resurgence of interest in n-acetylcysteine as a therapeutic agent, not only in patients with acute liver failure, but also in other groups of critically ill patients, such as those with sepsis, acute lung injury, and multiple organ failure. As with acute hepatic failure, published studies of other groups of critically ill patients have shown inconsistent findings, and the role of n-acetylcysteine in critically ill patients remains unclear.

Title

Acute hepatic coma treated by cross-circulation with a baboon and by repeated exchange transfusions

Author

Saunders SJ, Terblanche J, Bosman SC, Harrison GG, Walls R, Hickman R, BieBuyck J, Dent D, Pearce S, Barnard C

Reference

Lancet 1968; **2**: 585–588

Abstract

Not available

Summary

The case is reported of a 29-year-old woman who developed presumptive viral hepatitis. Her jaundice initially resolved after 6 weeks, but recurred soon after and was accompanied by a flapping tremor. Her neurological state deteriorated markedly to grade IV encephalopathy. She was treated with a regimen of daily exchange transfusion for 6 days, but despite some apparent improvement related to these procedures, this was not sustained. She duly became apneic, and after an unsuccessful seventh exchange transfusion, she underwent cross-circulation with a baboon. The baboon had been especially prepared by washing out the blood volume with lactate solution under hypothermia on bypass, and then replacing the blood volume with human blood compatible with the patient. After about 12 hours, spontaneous ventilation returned, and there was an improvement in conscious state and the treatment was terminated. She remained neurologically impaired for two further days, and then improved markedly to become fully conscious with no abnormal neurological signs. Her improvement persisted until publication of the case report.

Citation count 52

Related references

1. Stange J, Mitzner SR, Risler T *et al.* Molecular adsorbent recycling system (MARS): clinical results of a new-membrane-based blood purification system for bioartificial liver support. *Artif Organs* 1999; **23**: 319–330.
2. Sussman NL, Kelly JH. Extracorporeal liver support: cell-based therapy for the failing liver. *Am J Kidney Dis* 1997; **30** (5 Suppl 4): S66–S71.
3. Detry O, Arkadopoulos N, Ting P *et al.* Clinical use of a bioartificial liver in the treatment of acetaminophen-induced fulminant hepatic failure. *Am Surg* 1999; **65**: 934–938.

Key message

Complex forms of extracorporeal perfusion are possible in critically ill patients with acute liver failure and advanced encephalopathy. A focus on metabolic support (for example from functioning hepatocytes) rather than blood purification will most likely be successful.

Why it's important

This paper marks the beginning of a long and still-continuing struggle to find a clinically relevant artificial liver device that can be used as a bridge to regeneration or transplantation in patients with acute liver failure.

Strengths

This is a report of original and far-sighted ideas that must have stretched the boundaries of knowledge and technology in the late 1960s.

Weaknesses

This is a case report only. It is possible that the improvement after cross-circulation may have been incidental, and the patient may have recovered spontaneously without it.

Relevance

The precise technique used in this report is most unlikely to be used again because of concerns about transmission of infection, and immunological considerations. However, more than 30 years later, there remains a need to develop a safe and effective artificial liver for use in patients with acute liver failure.

Title

Effect of intravenous albumin on renal impairment and mortality in patients with cirrhosis and spontaneous bacterial peritonitis

Author

Sort P, Navasa M, Arroyo V, Aldeguer X, Planas R, Ruiz-Del-Arbol L, Castells L, Vargas V, Soriano G, Guevara M, Gines P, Rodes J

Reference

N Engl J Med 1999; **341**: 403–409

Abstract

BACKGROUND: In patients with cirrhosis and spontaneous bacterial peritonitis, renal function frequently becomes impaired. This impairment is probably related to a reduction in effective arterial blood volume, and is associated with a high mortality rate. We conducted a study to determine whether plasma volume expansion with intravenous albumin prevents renal impairment and reduces mortality in these patients. **METHODS:** We randomly assigned 126 patients with cirrhosis and spontaneous bacterial peritonitis to treatment with intravenous cefotaxime (63 patients), or cefotaxime and intravenous albumin (63 patients). Cefotaxime was given daily in dosages that varied according to the serum creatinine level, and albumin was given at a dose of 1.5 kg of body weight at the time of diagnosis, followed by 1 kg on day 3. Renal impairment was defined as nonreversible deterioration of renal function during hospitalization. **RESULTS:** The infection resolved in 59 patients in the cefotaxime group (94%) and 62 in the cefotaxime-plus-albumin group (98%) ($p = 0.36$). Renal impairment developed in 21 patients in the cefotaxime group (33%), and 6 in the cefotaxime-plus-albumin group (10%) ($p = 0.002$). Eighteen patients (29%) in the cefotaxime group died in the hospital, as compared with 6 (10 percent) in the cefotaxime-plus-albumin group ($p = 0.01$); at three months, the mortality rates were 41 percent (a total of 26 deaths), and 22% (a total of 14 deaths), respectively ($p = 0.03$). Patients treated with cefotaxime had higher levels of plasma renin activity than those treated with cefotaxime and albumin; patients with renal impairment had the highest values. **CONCLUSIONS:** In patients with cirrhosis and spontaneous bacterial peritonitis, treatment with intravenous albumin in addition to an antibiotic reduces the incidence of renal impairment and death, in comparison with treatment with an antibiotic alone.

Summary

The effect of intravenous albumin on renal impairment and mortality was studied in 126 patients with cirrhosis and spontaneous bacterial peritonitis. Patients were randomly assigned to receive treatment with intravenous cefotaxime or cefotaxime and intravenous albumin. Albumin was given at a dose of 1.5 g/kg body weight at the time of diagnosis, and 1 g/kg on day 3.

The infection resolved in a similar number of patients in both groups. However, the incidence of renal impairment was very much lower in the cefotaxime plus albumin group (6 patients; 10%) than in the cefotaxime alone group (21 patients; 33%). Furthermore, the mortality rates were lower in the cefotaxime plus albumin groups, i.e. 6 patients or 10% vs 18 patients or 29% for in-hospital mortality, and 14 patients (22%) and 26 patients (41%) at 3 months.

Patients treated with cefotaxime had higher levels of plasma renin activity than those treated with cefotaxime and albumin, and patients with renal impairment had the highest values.

The authors conclude that in patients with cirrhosis and spontaneous bacterial peritonitis, treatment with intravenous albumin in addition to an antibiotic reduces the incidence of renal impairment and death in comparison with an antibiotic alone.

Citation count 262

Related references

1. Guarner C, Soriano G. Spontaneous bacterial peritonitis. *Semin Liver Dis* 1997; **17**: 203–217.
2. Navasa M, Rimola A, Rodes J. Bacterial infections in liver disease. *Semin Liver Dis* 1997; **17**: 323–333.
3. Arroyo V, Gines P, Gerbes AL *et al*. Definition and diagnostic criteria of refractory ascites and hepatorenal syndrome in cirrhosis. International Ascites Club. *Hepatology* 1996; **23**: 164–176.

Key message

Spontaneous bacterial peritonitis is a common complication in patients with cirrhosis and ascites, and may be accompanied by renal impairment, development or worsening of encephalopathy, and increased risk of death. Treatment with non-nephrotoxic antibiotics has been associated with improved outcome, but volume expansion with albumin in addition to antibiotics results in further improvement in survival and a reduced incidence of renal impairment. The most likely explanation is that albumin infusion prevents hypovolemia and the subsequent activation of vasoconstrictor systems. However, mechanisms unrelated to plasma expansion cannot be ruled out.

Why it's important

This study provides strong evidence that intravenous albumin therapy should be given, in addition to antibiotic therapy, to patients with cirrhosis and spontaneous bacterial peritonitis. The effects of albumin therapy are not known in patients with organic nephropathy and serum creatinine concentration >265 µmol/L because these groups were excluded from the study.

Strengths

This is a well-designed, randomized, controlled trial from the group who virtually single-handedly have defined the management of ascites in cirrhosis.

Weaknesses

There are few. Further studies should investigate the effect of different doses of albumin, and whether other plasma expanders are equally effective.

Relevance

This study does not specifically involve patients treated in an intensive care unit. Nevertheless, spontaneous bacterial peritonitis is responsible for many admissions of cirrhotic patients to the ICU, as it is sometimes a silent precipitant of gastrointestinal bleeding, encephalopathy, and renal impairment, as well as overt sepsis. Indeed, it should be excluded in every cirrhotic patient admitted to the ICU. Consequently, advances in its treatment are very relevant to the ICU clinician. Furthermore, despite the current uncertainty as to the place of albumin therapy in critically ill patients, it seems clear that it confers a survival advantage to patients with cirrhosis and spontaneous bacterial peritonitis.

Burns

David N. Herndon MD, Robert E. Barrow PhD,
Somes C. Guha MD and Jay K. Bhama MD

Introduction

Survival of severely burned patients has improved substantially over the past 50 years. Before this period, shock, pain, sepsis, and multi-organ failure caused extremely high mortality rates. Mortality for children with burns covering 49% of the total body surface area (TBSA) in the 1940s was as high as 50%. Since that era, advances in burn care have improved survival such that today, a 50% predicted mortality rate is associated with TBSA burns of 98%. This has only been possible through advances in critical care, and the establishment of specialised burn centers.

Burn care, as we know it today, is a relatively new concept. Although its development spans the twentieth century, most progress has been made during the past four decades. In many areas, research data are either too recent to stand the test of time, or too outdated to be mindful of current interests. In caring for burn patients, the precise quantification of the extent of injury is a prerequisite for effective management. The size of the burn site is used in the resuscitation for initial shock, provision for infection control, the management of metabolic, hormonal and nutritional needs, and for adequate and timely skin coverage. Successful management of these events is a key determinant of the outcome in patients with massive burns.

The groundwork for our current strategy of fluid and electrolyte management was developed in 1930. This was followed by identifying the role of fluid movement from the circulatory space into burned tissue, which leads to hypovolemia and hypotension. The first formula for calculating fluid need was introduced in 1947. This was followed by the classic formula developed by Evans in 1952, which established a firm relationship between burn size and fluid requirements. In the UK, Muir and Barclay described another regimen for resuscitation, employing colloids. Currently, the most widely accepted and used protocol is the formula developed by Baxter and Shires. By the end of the 1960s, adequate fluid resuscitation had been established as a requirement for greatly reducing the incidence of early organ failure.

Topical antibacterial agents had been widely accepted by the late 1960s. Moyer introduced silver nitrate solution in 1961 as a prophylaxis for wound colonization and sepsis. This was replaced in 1962 by mafenide acetate (Sulfamylon). In 1964, 1% sulphadiazine (Silvadene) was introduced, and its success in controlling infection in burns has been presented. This has remained the mainstay of modern topical antimicrobial therapy.

Inhalation injury is a major determinant of burn morbidity and mortality. Thus, the management of inhalation injury remains a major challenge in acute burn care. As inhalation injury is a bronchiolar disease, a high frequency volumetric diffusive respirator was introduced in the 1980s, and showed some promise in the management of inhalation injury. Respiratory support at lower peak pressures decreased the incidence of barotrauma. Synchronized ventilatory support in small children, and the prophylactic use of high-frequency percussion ventilation in older children and adults with inhalation injury, has further reduced the mortality of inhalation injury.

In the past three decades, nutrition support of burn patients has gone through a significant and progressive evolution. Per duodenal feeding is now routinely used, and may alter hypermetabolism, bacterial translocation, and toxins during burn shock resuscitation.

However, intravenous hyperalimentation was found to increase mortality. Catecholamines remain the primary mediators of the hypermetabolic response.

Early burn wound closure is one basic principle of critical burn wound care. Excision of deep second degree and full-thickness burns is recommended within 24–48 hours of injury, with skin cover to follow. To cover the post-excision defect in major burns, banked homograft skin, Biobrane, and cultured skin have proven successful; however, the use of the expanded autograft with meshed skin has made the most significant difference in burn care.

Title

Fluid and electrolyte requirements in severe burns

Author

Evans EI, Purnell OJ, Robinett PW, Batchelor A, Martin M

Reference

Ann Surg 1952; **135**: 804–817

Abstract

Burn shock treatment requires the replacement of circulating plasma and red blood cell components. While there is a growing realization that adequate amounts of salt must be given, the question of just how much the severely burned patient needs remains unanswered. This study develops and tests a simple formula for calculating colloid and electrolyte requirements in severely burned patients during the first 48 hours postburn. Data indicate that approximately the same plasma deficit per weight occurred in human burns involving 20 percent of the body surface as found in previous studies on dogs, in which approximately 1 ml of plasma was lost for each percent body surface area burned. A simple formula based on the administration of 1 ml plasma per kilogram body weight per percentage of burn during the first 24 hours was tested on sixty-eight severely burned patients. Arbitrarily, the same quantity of electrolyte was given the first day, and one-half these amounts of colloid and electrolyte were given on the second day. An additional two liters of non-electrolyte 5% glucose in water was given intravenously to the more extensively burned patients to ensure an adequate urine output and take care of insensible fluid loss. The results of this study show that slightly more than 80% of the patients with less than a 50% TBSA burn survived. It was emphasized that great caution must be exercised in the management of patients of any age with burns more extensive than 50% of the total body surface.

Summary

A simple but practical formula has been presented for the calculation of the fluid requirements of the severely burned patient during the first few days of the burn shock. There is little difficulty in the management of fluid therapy following the use of almost any formula with burns covering up to 20% of the total body surface area, especially if the patient is not over 50 years of age. There is little difficulty in the care of the patient with a 20–25% burn when the fluid therapy adheres strictly to the formula. Moderately close clinical observation is required with burns of 30% of the body surface. However, when the burn comprises $\geq 40\%$, the problem of clinical management is so complicated that any formula for fluid estimates must be employed with caution and great care. The decisions for clinical management of fluid therapy take precedence over the precise application of any formula. Of greater import is what the clinician learns by careful bedside observation. The course of events in a seriously burned patient can change rapidly, and warrants the most critical clinical examination, and early institution of appropriate therapies.

Citation count

160

Related references

1. Kyle MJ, Wallace AB. Fluid replacement in burnt children. *Br J Plast Surg* 1951; 194–204.
2. Baxter C, Shires T. Physiological response to crystalloid resuscitation of severe burns. *Ann NY Acad Sci* 1968; 874–894.

3. Bocanegra M, Hinostroza F, Kefalides N, Markley K, Rosenthal S. A long-term study of early fluid therapy in severely burned adults – simultaneous comparison of saline solution alone or combined with plasma. *JAMA* 1966; **195**: 128–134.

Key message

A simple formula based on body weight and percent body burn can be applied successfully to patients' total body surface area burns up to 50%.

Why it's important

The previous body surface area calculation for fluid resuscitation caused pulmonary edema and did not take into account differences in body weight. This formula uses weight and burn size, and has been successful in resuscitating burns covering up to 50% of body surface area.

Strengths

This was one of the first simple, practical formulas for the immediate calculation of fluid requirements of severely burned patients during the first 2 days of the shock phase.

Weaknesses

This formula is not directly applicable to burns over 60% body surface area.

Relevance

Early fluid resuscitation of extensive burns is of primary importance to patient survival. This easy to calculate formula provides the physician with a means of quickly estimating the correct volume for the fluid resuscitation of extensive burns.

Title

The successful control of burn wound sepsis

Author

Lindberg RB, Moncrief JA, Switzer WE, Order SE, Mills W Jr

Reference

J Trauma 1965; **5**: 601–616

Abstract

Burn wounds can be contaminated from a variety of sources. The intensive use of antibiotics may clear the blood of gram-negative bacilli in burn septicemia, but the septic wound remains a lethal focus. Therefore, there is an obvious need for prevention of invasive burn wound infection if mortality from severe burns is to be lowered. Such prevention in experimental *Pseudomonas* burn wound sepsis by use of a topically applied chemotherapeutic formulation containing p-aminomethylbenzene sulfonamide (Sulfamylon) is reported. A rat model of *Pseudomonas* burn wound sepsis was used for testing topical therapy. At various intervals following implantation of *Pseudomonas* on the burn wounds, Sulfamylon was applied topically. Survival of virtually all animals occurred if this topical drug was applied within 48 hours of seeding the burn. Delay beyond 48 hours resulted in significantly fewer survivors. A clinical trial to test the efficacy of 10% Sulfamylon in a water-soluble base was started in December 1963. The initial results were sufficiently favorable to allow all suitable acute admissions to begin treatment. With the exception of minor injuries and of patients admitted late in the course of illness, all patients were treated as soon as the patients' burn was cleaned and evaluated. The burn cream is applied twice daily, with a sterile gloved hand, to cover the wound in a layer approximately 1/16 inch thick. Therapeutic response to burn cream was prompt and gratifying. Patients with burns of between 30 and 50% to body surface usually tolerated the cream well, and progressed with no symptoms of gross evidence of invasive infection. Wounds of above 50% also remained uninvaded. Burn mortality versus extent of burn is presented in the Table. Causes of death are not separated, nor are all deaths assumed to be caused by infection. The striking change in overall mortality in 1964 is apparent; in those with up to 40% total body burn, no deaths occurred in the Sulfamylon treated patients. In all preceding years, those with burns above 30% ran a significant mortality risk. In the severe burn, from 40 to 50% of body surface, reduction of mortality was significant, but above 50% burn, there is no indication that mortality was affected.

Table 8-1. *Burn mortality versus extent of burn*

Year		% burn									
		0–10	10–20	20–30	30–40	40–50	50–60	60–70	70–80	80–90	90–100
1961	% mortality	0	0	28.5	30	67	50	71	100	100	100
1962	% mortality	0	0	8	47	63	87	100	90	100	100
1963	% mortality	0	8.3	8	42	59	73	63	86	100	100
1964	% mortality (Sulfamylon-treated)	0	0	0	0	20	67	83	86	84	100

A problem that has caused concern in a small number of patients with large burns is hyperchloremic acidosis after two to four days of treatment, due to Sulfamylon absorption. Most patients compensate for this acidosis without harm. Absorption appears to be more

rapid in second-degree burns and to some extent is probably proportional to the total size of burns. Reduced bacterial counts and increased survival of patients with burns in the range of 30 to 60% body surface appear to be closely associated. With the sepsis problem controlled, a better understanding of other aspects of burn wound pathology may develop.

Summary

A method for suppressing infection in severe burns has been developed: 10% p-aminomethylbenzene sulphonamide HCl (Sulfamylon) in a water-soluble base was applied directly to burns of various magnitude in 100 patients. Absence of burn wound sepsis in the treated patients, reduced total bacterial counts, particularly of *Pseudomonas*, and increased patient survival, all indicate that topical therapy in burns is valid, and that burn wound sepsis was successfully controlled. Occasional side reactions were noted, the principal problem being acidosis due to excessive absorption of the drug, which requires further study.

Citation count 153

Related references

1. Pruitt BA Jr, O'Neil JA, Moncrief JA, Lindgberg RB. Successful control of burn wound sepsis. *JAMA* 1968; **203**: 1054–1056.
2. Fox CL, Ruppole B, Stanford W. Control of *Pseudomonas* infection in burns with silver sulfadiazine. *Surg Gynecol Obstet* 1969; **128**: 1021–1026.
3. Markley K, Gurmendi G, Chavez P, Bazan A. Fatal *Pseudomonas* septicemias in burned patients. *Ann Surg* 1957; **145**: 175–181.

Key message

By suppressing bacterial growth, areas of viable epithelium were preserved so that re-epithelialization occurred, thus the area requiring ultimate skin grafting was reduced.

Why it's important

Nearly 65% of burn wound fatalities in 1965 were due to septicemia, with pseudomonas a primary finding.

Strengths

The use of Sulfamylon in large burns kept the wounds uninvaded by bacterial growth, and was particularly valuable in treating deep second-degree burns.

Weaknesses

As in many early studies, a dose–response relationship has been set aside until a later study. This study would be important from the standpoint of both what is an effective dose, and what are the toxic side effects of large amounts placed on the skin.

Relevance

The early uses of Sulfamylon begun in 1963 were so successful that all acute admissions at this institute were treated with Sulfamylon in a water-soluble base. A marked decrease in mortality from gram-negative burn wound infection occurred not only at this institute, but subsequently worldwide, through the routine use of this and other topical antimicrobial agents that followed it.

Title

Acute gastroduodenal disease after thermal injury: an endoscopic evaluation of incidence and natural history

Author

Czaja AJ, McAlhany JC, Pruitt BA

Reference

N Engl J Med 1974; **291**: 925–929

Abstract

The incidence and history of acute gastroduodenal disease after thermal injury were determined in 32 adult patients. Gastric erosions were present in 86% of the patients with large burns, and 74% had lesions within 72 hours after the burn. In seven patients (22%) a gastric ulcer developed. Ulcerations occurred only in diffusely abnormal areas, and were not discovered prior to 72 hours after the burn. Nine patients (28%) had duodenal ulceration. Eight patients had concomitant gastric disease. In two cases, an ulcer was observed to evolve from an erosive 'duodenitis'. The early development, morphology, and histology of the lesions suggested ischemic damage of the gut mucosa. Nine of 15 patients studied serially had progression of mucosal disease; sepsis, hypotension, and hypoxia complicated the clinical course. Life-threatening hemorrhage or perforation occurred in 8 of 9 patients with ulcers.

Summary

Acute ulceration is the most common life-threatening gastrointestinal complication after thermal injury. Retrospective clinical and post-mortem studies represent only the most advanced stages of this pathological process. To determine the incidence and natural history of this acute gastroduodenal disease, early serial endoscopic examinations of the stomach and duodenum were performed. Acute duodenal disease without ulceration was present in 14 of the 21 patients (67%) evaluated within 72 hours after the burn. All patients with a duodenal ulcer had an accompanying 'duodenitis'. Mucosal damage was observed within hours after burn. Understanding the factors that affect the injured mucosa during the immediate period after the burn may help prevent the ulceration of early lesions, and the associated life-threatening complications.

Citation count 193

Related references

1. McAlhany JC Jr, Colmic L, Czaja AJ, Pruitt BA Jr. Antacid control of complications from acute gastroduodenal disease after burns. *J Trauma* 1976; **16**: 645–648.
2. Sevitt S. Duodenal and gastric ulceration after burning. *Br J Surg* 1967; **54**: 32–41.
3. Czaja AJ, McAlhany JC, Pruitt BA Jr. Acute duodenitis and duodenal ulceration after burns. Clinical and pathological characteristics. *JAMA* 1975; **232**: 621–624.

Key message

Acute gastroduodenal disease develops in the majority of patients soon after thermal injury, and it frequently remains clinically inapparent. Gastric erosion was identified in 86% of the patients given serial gastroduodenoscopies after a severe thermal injury, and 74% had lesions identified within 72 hours of the burn; 22% developed a gastric ulcer.

Why it's important

Acute ulceration of the stomach and duodenum is one of the most common life-threatening gastrointestinal complications after thermal injury, with ulceration, hemorrhage, and perforation representing the most advanced stages.

Strengths

The high percentage of gastric erosion or gastric lesions directly demonstrated after thermal injury is quite convincing.

Weaknesses

There was general representation in age and burn size; however, the population studied was nearly 98% male. Thus, this study becomes one that determines the incidence of acute gastroduodenal disease after a thermal injury in males. Subsequent use of ulcer prophylaxis regimens has reduced the incidence of those complications.

Relevance

This manuscript aptly points out that a better understanding of the factors that affect the gut mucosa immediately after a thermal injury may prevent the progression of early lesions into ulcers, and thus attenuate the associated life-threatening complications.

Title***Dietary requirements of patients with major burns***

Author

Curreri PW, Richmond D, Marvin J, Baxter C

Reference*Am Diet Assoc* 1974; **65**: 415–417

Abstract

During the acute post-burn period, a marked increase in resting metabolic rate is observed until wound closure. Rapid weight loss during the post-burn period has been associated with delayed epithelialization of partial thickness burns, development of unhealthy granulation tissue in full thickness burns, and an increase in pulmonary sepsis. The increased caloric demand of the burned patient requires augmented exogenous administration of calories, if maintenance of body weight is desired. Daily caloric needs are rarely satisfied unless minimum caloric requirements are known, and extraordinary methods are used to administer sufficient exogenous calories. This study was designed to derive an empirical formula by which daily caloric requirements in adult patients, based on body weight and magnitude of injury (percentage of body surface burn), could be rapidly and reliably estimated by physicians and ancillary personnel, allowing appropriate early dietary supplementation by both enteral and parenteral routes. *Methods*: Nine adult patients (three women, six men) with total body surface (TBS) burns between 40 and 73% (mean 53%) were studied. Wound closure had not been accomplished in any patient during the study. Daily caloric intake was calculated, using standard tables for estimating caloric value of enteral foods and standard conversion formulas for caloric values of carbohydrate and protein in parenteral solutions. A high-protein, high caloric, selective house diet was served to most. When the percentage of weight change was compared with average daily caloric intake (expressed as percent of an empirical ideal caloric intake) by regression analysis, a regression line which closely paralleled measured data ($r = 0.7$) was obtained if ideal caloric intake was empirically determined by the following formula: ideal caloric intake = $25 \times \text{weight (kg)} + 40 \times \text{percent TBS (total body surface) burn}$.

Summary

The daily average caloric intake of nine adult patients with total body surface burns >40% was calculated by analysis of all administered enteral and parenteral nutrients for 20 days following burn. Weight change over the study period was monitored. Regression analysis of the data allowed calculation of a formula for estimating energy expenditure in severely burned adults without resorting to direct or indirect calorimetric determinations. Knowledge of the daily caloric requirements allows administration of appropriate dietary intake. The ideal daily caloric intake expressed by the sum of $25 \times \text{weight (kg)}$ and $40 \times \% \text{ TBS (total body surface) burn}$ would be expected to minimize weight loss in adults during the acute post-burn period.

Citation count

119

Related references

1. Sutherland A. The nutritional care of the burned patient. *Br J Plast Surg* 1955; 68–74.
2. Herndon DN, Barrow RE, Stein M *et al*. Increased mortality with intravenous supplemental feeding in severely burned patients. *J Burn Care Rehabil* 1989; **10**: 309–313.

Key message

A formula for calculating caloric requirements of severely burned patients is presented.

Why it's important

The suggested formula for caloric needs allows the physicians, nurses, allied health personnel, and dieticians to set a daily dietary program which should minimize weight loss and the complications of severe post-burn malnutrition.

Strengths

Rapid estimations of early dietary supplementations can be made by physicians and ancillary burn care personnel.

Weaknesses

The formula was based on only nine burn patients, three women and six men.

Relevance

An empirical formula was derived by which daily caloric requirements for adult burn patients can be rapidly and reliably estimated by physicians and ancillary personnel from both body size and magnitude of the surface burn, which allows appropriate early dietary supplementation. The widespread utilization of these guidelines has markedly reduced mortality from malnutrition after burns.

Title

Catecholamines: mediator of the hypermetabolic response to thermal injury

Author

Wilmore DW, Long JM, Mason AD, Skreen RW, Pruitt BA Jr

Reference

Ann Surg 1974; **180**: 653–669

Abstract

Hypermetabolism characterizes the metabolic response to thermal injury, and the extent of energy production is positively related to the rate of urinary catecholamine excretion. Alpha and beta adrenergic blockade decreased metabolism from 69.6 ± 5.3 Kcal/m²/hr to 57.4 ± 5.2 ($p < 0.01$), and infusion of 6 µgm epinephrine/minute in normal men significantly increased metabolic rate. Twenty non-infected burned adults with a mean burn size of 45% total body surface (range 7–84%) and four normal controls were studied in an environmental chamber, at two or more temperatures between 19° and 33°C, with vapor pressure constant at 11.88 mmHg. All burn patients were hypermetabolic at all temperatures studied, and their core and mean skin temperatures were significantly elevated above control values. Between 25° and 33°C ambient, metabolism was unchanged in controls and burns of less than 40% total body surface (48.9 ± 4.6 Kcal/m²/hr vs. 48.9 ± 4.5), but metabolic rate decreased in larger burns in the warmer environment (72.0 ± 1.9 vs. 65.8 ± 1.7 , $p < 0.001$). At 19°C, metabolism and catecholamines increased, except in four nonsurvivors who became hypothermic with decreased catechol elaboration. Metabolic rate in ten patients with bacteremia was below predicted levels, while catecholamines were markedly elevated, suggesting interference with tissue uptake of the neurohormonal transmitters. Feeding burn patients or administering glucose and insulin improved nitrogen retention and altered substrate flow, but did not significantly reduce urinary catecholamines or metabolic rate. Burned patients are internally warm, not externally cold, and catecholamines appear to mediate their increased heat production. Hypermetabolism may be modified by ambient temperature, infection, and pharmacologic means. Alterations in hypothalamic function due to injury, resulting in increased catecholamine elaboration, would explain the metabolic response to thermal injury.

Summary

Hypermetabolism characterizes the metabolic response following thermal injury. In this study, the average core temperature of the burn patients was elevated above normal, and the mean skin temperature was increased in all non-hypothermic patients at all ambient conditions studied when compared with normal, demonstrating that the burn patients are internally warm and not externally cold. These patients, however, were hypermetabolic in a warm environment, with elevated core and skin temperatures, and, when equilibrated with a cooler environment, continued or slightly increased their hypermetabolism while their core and skin temperature remained higher than those of the normal controls. Thus, the hypermetabolic response is thought to be related to an endogenous reset in metabolic activity. Alpha blockade did not affect heat production in the burn patients, while combined alpha and beta blockade alone significantly reduced metabolic rate. The increased heat production thus appears to be mediated by catecholamines. Associated with the hypermetabolic response following injury is the negative nitrogen balance and

loss of intracellular constituents. Sympathetic activity returns to normal with closure of the burn wound, and a normal relationship between insulin, catecholamines, and glucagon is re-established. Afferent or hormonal stimuli from the injury appear to influence hypothalamic centers to elevate central temperature (and possibly metabolic) set point, increasing sympathetic nervous system activity, and resulting in the hypermetabolism characteristic of thermal injury.

Citation count 496

Related references

1. Hinton P, Allison SP, Littlejohn S, Lloyd J. Insulin and glucose to reduce catabolic response to injury in burned patients. *Lancet* 1971; **1**: 767–769.
2. Wolfe RR, Durkott MJ, Allsop JR, Burke JF. Glucose metabolism in severely burned patients. *Metabolism* 1979; **28**: 1031–1039.
3. Herndon DN, Barrow RE, Kunkel KR, Broemeling LD, Rutan RL. Effect of human recombinant growth hormone on donor site healing in severely burned children. *Ann Surg* 1990; **212**: 424–431.

Key message

Burn patients reset their thermal regulatory set-point upwards, thus increasing the discharge of sympathetic impulses to increase heat production and substrate mobilization to maintain a new elevated core temperature.

Why it's important

This paper defines the relationship between surface cooling and hypermetabolism in a controlled ambient environment, in an effort to determine the mediator of the profound hypercatabolic response, and assesses the effect of nutritional support on the hypermetabolic response following thermal injury.

Strengths

This study clearly established that the hypermetabolic response is mediated by catecholamines.

Weaknesses

Only four subjects served as controls. The ages ranged from 20 to 34 years in controls, as compared with 14–49 years for burn patients.

Relevance

Burn patients do not have the capability of adjusting their metabolic rates to normal levels in a warm environment. Nutritional support and hormonal modulation of the response was made apparent, and began an area of investigation and treatment of this response.

Title

The estimation of areas of burns

Author

Lund CC, Browder NC

Reference

Surg Gynecol Obstet 1944; **79**: 352–358

Abstract

The proportionate area of skin burned is recognized as a useful guide not only to the prognosis of burns, but more importantly as a guide to burn treatment. After an estimate of the size of the area of the burn and its proportion to the total body surface area, an estimate of the amount of plasma needed during the first day of treatment can be made. Previous diagrams and standards for recording burn area in children and adults are over-simplified, and contain certain errors that could be avoided. There are two previous articles concerning body surface area that were not concerned with the problems of measuring basal metabolism. In this study, a new table and diagrams have been constructed that avoid the systematic errors that can occur when Berkow's table for adults is applied to children.

Summary

In studies of burns, an easy, accurate method of visual estimation of the percentage of surface area is important. Certain systematic errors of magnitude can occur when a table for adults is applied to children. A new table and diagrams have been constructed that avoid these and other systematic errors. It is estimated that this table and these diagrams should be applicable, without serious error, to at least 99.5% of all cases of burns.

Citation count 307

Related references

1. Kyle MH, Wallace AB. Fluid replacement in burnt children. *Br J Plast Surg* 1951; **3**: 194 (rule of 9).

Key message

A technique for estimating the percentage of the total body surface area burn is presented, which can be used as a guide for fluid replacement.

Why it's important

The area of burned skin is a central guide on which acute fluid resuscitation of burns is based. The universal availability of Lund Browder diagrams in emergency treatment facilities has allowed reliable recording of the extent of injury to direct therapy.

Strengths

A new determination for areas of body subdivisions is stratified into different ages for children to minimize the errors due to surface proportional changes in the head and lower extremities.

Weaknesses

There was some difficulty in deciding the best percentages for newborn infants.

Relevance

There are certain systematic errors of magnitude that occur when surface area tables for adults are applied to children. This paper presents a new table that eliminates these systematic errors.

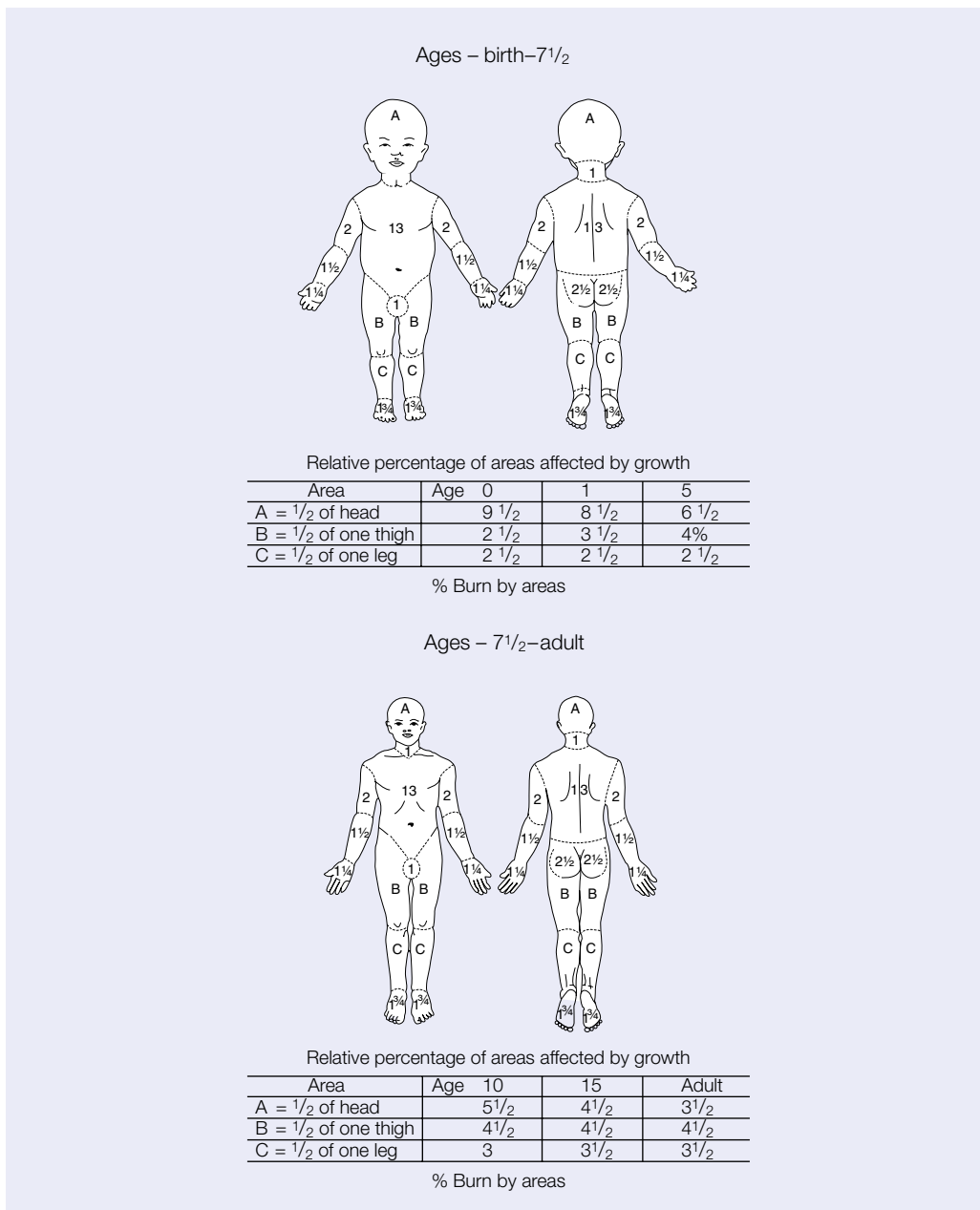

Fig. 8-1. The percentages of each area as visualized when the area is fixed at each age are printed on the diagrams. At the bottom are the figures for the varying areas. The chart with the adult figure is used for ages 7½ years and up, and the one with the child's figure for younger children

Title

Immunosuppression and temporary skin transplantation in the treatment of massive third degree burns

Author

Burke JF, Quinby WC, Bondoc CC, Cosimi AB, Russell PS, Szyfelbein SK

Reference

Ann Surg 1975; **182**: 183–197

Abstract

A method of burn treatment (immunosuppression and temporary skin transplantation) for patients suffering from massive third-degree burns is evaluated. The method is based on the prompt excision of all burn eschar, and immediate closure of the wound by skin grafts. Total wound closure is achieved before bacterial infection or organ failure takes place by carrying out all initial excision and grafting procedures within the first ten days post burn, and supplementing the limited amount of autograft with allograft. Continuous wound closure is maintained for up to 50 days through immunosuppression. Both azathioprine and ATG have been used. During the period of immunosuppression, allograft is stepwise excised and replaced with autograft as autograft donor sites regenerate for recropping. Bacterial complications are minimized by housing the patient in the protected environment of the Bacteria Controlled Nursing Unit. Intensive protein and caloric alimentation are provided, and 0.5% aqueous AgNO₃ dressings are used. Eleven children have been treated, and seven have been returned to normal, productive schooling.

Summary

The experience in the treatment of massive third-degree burns reported indicates that the most important factor in the successful treatment of extensive skin destruction following thermal injury is the prompt removal of dead tissue, and immediate wound closure. The actual cause of burn death is not related to the biological effect of thermally destroyed skin, but to the metabolic and bacterial consequences of a large, open wound. In the case of a massive thermal injury, if recovery of skin function through healing of partial-thickness injury and/or wound closure through skin graft does not take place within a couple of weeks, the patient dies of a complex sequence of metabolic and bacteriological abnormalities. In the patients reported, immunosuppression and temporary skin transplantation have been used successfully to improve mortality.

Citation count 86

Related references

1. Chamber K, Batchelor JR. Influence of defined incompatibilities and area of burn on skin homograft survival in burned subjects. *Lancet* 1969; **1**: 16–18.
2. Koumans RKJ, Burke JF. Skin allografts and immunosuppression in the treatment of massive thermal injury. *Surgery* 1969; **66**: 89–96.

Key message

In patients with massive third-degree burns, prompt excision and immediate wound closure by skin graft from cadavers within the first 10 days post-burn can prevent bacterial

infection and organ failure. Continuous wound closure is maintained for up to 50 days through immunosuppression.

Why it's important

When total burn wound closure is complete within the first 10 days after burn, bacterial infection or organ failure is attenuated.

Strengths

Unprecedented survival of massive burns excised and covered with cadaver skin.

Weaknesses

Immunosuppression later proved to be unnecessary, as patients are endogenously immunosuppressed for prolonged periods.

Relevance

The actual cause of burn death is not related to the biological effect of thermally killed skin, but to the metabolic and bacterial consequences of a large open wound. This is the first study in which cadaver skin was used to cover wounds after massive excision of large burns. This technique has allowed patients with burns >80% TBSA to routinely survive, where they previously would have perished.

Title

Successful use of a physiologically acceptable artificial skin in the treatment of extensive burn injury

Author

Burke JF, Yannas IV, Quinby WC, Bondoc CC, Jung WK

Reference

Ann Surg 1981; **194**: 413–428

Abstract

A bilayer artificial skin, composed of a temporary Silastic epidermis and a porous collagen-chondroitin 6-sulfate fibrillar dermis, has been used to physiologically cover up to 60% of the body surface area following prompt excision of burn wounds. This was carried out in ten patients whose total burn size covered 50–95% of their body surface area. Following grafting, the dermal portion is populated with fibroblasts and vessels from the wound bed. The anatomic structure of the artificial dermis resembles normal dermis, and serves as a template for the synthesis of new connective tissue and the formation of a 'neodermis,' while it is slowly biodegraded. This artificial skin has physiologically closed excised burn wounds for periods of time up to 46 days before the Silastic epidermis was removed. At the time of election when donor sites are ready for reharvesting, the Silastic epidermis is removed from the vascularized artificial dermis and replaced with 0.004 auto-epidermal graft in sheet or meshed form. Clinical and histologic experience in a relatively short follow-up period (2–16 months) indicates that 'neodermis' retains some of the anatomic characteristics and behavior of normal dermis, thus promising improvement in the functional and cosmetic results, as well as providing physiologic function as a skin substitute. The artificial skin is easily sterilized and stored at room temperature, capable of large scale production, and immediately available for grafting, indicating its potential for easy and relatively economic use in the burn patient.

Summary

An insoluble, native collagen preparation from bovine hide was used as a major component of an artificial dermis used to cover burn wounds. The development in the design of this artificial dermis has been one that is capable of adhering to the excised wound bed with an optimal modulus of elasticity and strength. This artificial material has the ability to induce migration of normal fibroblasts and vessels, which synthesize new connective tissue matrix while biodegrading the artificial material at a controlled rate. Microscopic examination of a successful split-thickness epidermal skin covering over an artificial implant showed a well-healed epidermis along with a moderately thick dermis. No remnant of the bovine lattice was found. In the patients reported, there was no infection in the grafted areas, and clinical and histological findings confirmed that there was no inflammatory or foreign body response. The authors felt that contraction was minimal, and no hypertrophic scar had developed. Further, the efficacy and technical complexity of the artificial skin would be simplified if epidermal cells were implanted in the bilayer material at the time of initial grafting.

Citation count 390

Related references

1. Heimbach D, Luterman A, Burke J *et al.* Artificial dermis for major burns, a multi-center randomized clinical trial. *Ann Surg* 1988; **208**: 313–320.

Key message

The clinical behavior of the artificial skin tested indicates a degree of success in meeting the design criteria, leading to a neodermis which provides some of the physical and cosmetic properties of normal dermis.

Why it's important

Artificial dermis, if designed with the proper physicochemical, biochemical, and mechanical properties, would act as a biodegradable dermal template, leading to the synthesis of a neodermis.

Strengths

Clinical evaluation and histological studies show that the connective tissue synthesized by cells invading the artificial dermis was anatomically similar to normal dermis, and not scar fibrosis.

Weaknesses

While the clinical efficacy of the artificial skin indicated a degree of success, only 10 patients were reported with a relatively short recovery period of 2–16 months. Further, there is no evidence indicating that the functional and cosmetic benefits will persist for a longer period of time.

Relevance

Artificial dermis permits early wound closure with adherence properties similar to allograft and, when covered with subsequent epidermal graft, provides a cover equal to that achieved with available skin grafting techniques.

Title

The influence of inhalation injury and pneumonia on burn mortality

Author

Shirani KZ, Pruitt BA Jr, Mason A Jr

Reference

Ann Surg 1987; **205**: 82–87

Abstract

The records of 1058 patients treated at a single institution over a five-year period, from 1980–1984, were reviewed to assess the specific effects of inhalation injury and pneumonia on mortality in burn patients. Of these patients, 373 (35%) had inhalation injury diagnosed by bronchoscopy and/or ventilation perfusion lung scan. Of the 373 patients, 141 (38%) had subsequent pneumonia. In patients without inhalation injury, pneumonia occurred in 60 of 685 (9%). A multiple logistic equation was developed to estimate expected mortality at any age and burn size for patients without inhalation injury or pneumonia, with either alone, or with both. Subtraction of the expected mortality without either inhalation injury or pneumonia from the expected mortality in the presence of either or both permitted the estimation of additional mortality attributable to these complications. Inhalation injury, alone, increased mortality by a maximum of 20%, and pneumonia by a maximum of 40%, with a maximum increase of approximately 60% when both were present. The influence on mortality was maximal in the midrange of expected mortality without these complications for any age group. These data indicate that inhalation injury and pneumonia have significant, independent, additive effects on burn mortality, and vary with age and burn size in a predictable manner.

Summary

A retrospective review was made of 1058 burn patients treated at a single institute over a 5-year period. In all, 35% were diagnosed with an inhalation injury, and 38% with subsequent pneumonia. Inhalation injury increased mortality by a maximum of 20% at any age and burn size, and pneumonia by a maximum of 40%. A maximum mortality of approximately 60% was observed when both inhalation injury and pneumonia were present. Thus, inhalation injury and pneumonia have independent and additive effects on burn mortality, which vary with age and burn size.

Citation count

176

Related references

1. Pruitt BA Jr, Flemma JF, DiVencenti FC *et al.* Pulmonary complications in burn patients. *J Thorac Cardiovasc Surg* 1970; **59**: 7–20.
2. Herndon DN, Barrow RE, Traber DL, Rutan TC, Rutan RL, Abson S. Extravascular lung water changes following smoke inhalation and massive burn injury. *Surgery* 1987; **102**: 341–349.

Key message

Burn patients' survival is reduced when complicated by inhalation injury or pneumonia. Both complications affect mortality in a predictable manner, with little effect on mortality

in small burns or very large burns where the physiological capacity is exceeded by the injury alone. It is in the mid range of severity that pulmonary complications may make a sublethal injury lethal. In these patients, better management of the pulmonary complication may improve survival.

Why it's important

This is the first report that inhalation injury and pneumonia have been related to age and burn size-dependent patient mortality.

Strengths

1. 1058 burn patients treated at a single institution were studied over a 5 year period.
2. A basic age and burn size-specific index, based on the authors' experience in the treatment of >6000 burn patients over the past three decades, was used to assess severity of injury.
3. The authors helped to answer an important question concerning the specific contribution of inhalation injury and pneumonia to burn mortality.

Weaknesses

The authors suggest that the inhalation injury they observed may impair surfactant production. One slight criticism might be that the article referenced used forced inhalation of sawdust smoke and ignited kerosene (5:2 wt:wt) in dogs with a thoracotomy to ensure that smoke, fumes, and gases reached the alveoli. These findings suggest a physical inactivation or alteration of the preformed surfactant, and not impaired production. This is only a small criticism; however, what exactly causes lung function changes after an inhalation injury is important with regard to treatment.

Relevance

In burn patients, it is generally recognized that the influence of pulmonary complications is one of the prime contributors to mortality. From the data provided, a burn population has been identified that can substantially benefit from better management of the pulmonary complications from inhalation injury or pneumonia.

Title***Primary burn excision and immediate grafting: a method of shortening illness***

Author

Burke JF

Reference*J Trauma* 1974; **14**: 389–395

Abstract

A consecutive series of 200 children, 2 months to 16 years of age, with a 10 to 65 percent total body surface area full-thickness flame or scald burn were studied. These patients were admitted between January 1969 and January 1973, and broken into two subgroups of patients treated with silver nitrate therapy alone without primary excision, or treated with primary excision, immediate grafting, and silver nitrate therapy as an adjunct to dress donor sites and unexcised burn as well as the newly grafted areas. Silver nitrate therapy used alone followed standard procedure. Split-thickness skin grafts were obtained with an air-driven dermatome at the time of the operative procedure, but before excision of burn eschar. Complications observed in burn patients include wound sepsis, bacteremia, pulmonary complications, and GI bleeding. The group treated with primary excision and immediate graft combined with silver nitrate has a lower incidence of complications in all the complication categories except GI bleeding. The mortality rates showed that 4% of the patients undergoing primary excision, and 11% of the patients receiving silver nitrate therapy alone, died during the study period. The most frequent cause of death in both groups was from bacterial complications in the form of septicemia. The healing times were reduced in those treated with excision plus silver nitrate from 75 days to 90 days for those with 20% to 39% burn sizes, compared to silver nitrate alone, and from 101 days to 62 days for the 40% to 65% body surface area burns, respectively. From their study, it was concluded that the long-term cosmetic results following primary excision and immediate grafting were far superior to those achieved with silver nitrate alone.

Summary

A consecutive series of 100 children with burns covering 10–65% of the body surface were treated with primary burn excision and immediate grafting, supplemented with topical 0.5% AgNO₃ therapy. This group was compared with a similar group of 100 children treated with topical AgNO₃ alone. In all categories examined, the primarily excised group was improved over the group treated with topical therapy alone, and the time required to close the burn wound with isograft skin was reduced by one-third to one-half the time required for wound closure with topical therapy alone. These results encourage the routine use of primary excision and immediate grafting of all patients whose body surface burn extends between 10% and 65% of the body surface.

Citation count

138

Related references

1. Janzekovic Z. A new concept in the early excision and immediate grafting of burns. *J Trauma* 1970; **10**: 1103–1108.

2. Engrav LH, Heimbach DM, Reus JL, Harnar TJ, Marvin JA. Early excision and grafting vs. nonoperative treatment of burns of indeterminant depth: a randomized prospective study. *J Trauma* 1983; **23**: 1001–1004.
3. Herndon DN, Barrow RE, Rutan RL, Rutan TC, Desai MH, Abston S. A comparison of conservative *versus* early excision. *Ann Surg* 1989; **209**: 547–553.

Key message

The number of days needed to achieve wound closure, complications observed in patients surviving thermal injury, and long-term cosmetic results following primary excision and immediate grafting are improved compared with those treated with silver nitrate therapy alone.

Why it's important

Early excision and immediate grafting require one-third to one-half the time in hospital required for wound closure with topical therapy alone. This means a reduction in patient suffering and hospital costs.

Strengths

A study population of 200 children with burns covering 10–65% of their body surface area was used, and the highly qualified surgeons performing the excision and grafting impart a high degree of validity to the study.

Weaknesses

This study did not compare their hospital stays with the tangential excision technique. The question of whether excision of burn eschar which leaves the undamaged fat is better in the long term compared to excision which goes arbitrarily to fascia remained unresolved in this study.

Relevance

Early excisional therapy has been helpful in improving both morbidity and mortality in severely burned children.

Trauma

Frederick A. Moore MD, FACS

Introduction

Over the past century, shock and subsequent failure of vital organ function has been recognized to be one of the major causes of post-injury death (brain injury being the other). In early World War I, injured soldiers did not receive early resuscitation, and frequently died in the battlefield of cardiac failure. This was presumed to be the result of wound toxins. As the carnage continued, physiologists worked with surgeons in the casualty clearing stations to demonstrate that loss of blood volume was a prime factor in traumatic shock. By the end of World War I, surgical hemostasis became a recognized priority (e.g. amputation for compound fractures, laparotomies for abdominal wounds), and blood transfusions became available in a limited fashion. By World War II, blood plus plasma resuscitation became the standard of care. In addition, injured soldiers were rapidly transported for definitive care in field hospitals. As a result, more soldiers survived their initial traumatic insult, but the more severely injured often succumbed to acute renal failure. After World War II, Wiggers developed the classic 'controlled' hemorrhagic shock model, which documented that if severe shock was allowed to persist for several hours, an irreversible shock state occurred from which the animals could not be resuscitated. In the 1960s, Shires and associates used the 'Wiggers Preparation' to document that extracellular fluid deficits coexist with traumatic shock and are best replenished with balanced salt solutions. Blood plus balanced salt solution then became the standard of care in the Vietnam War. Additionally, battlefield casualties were more rapidly transported by helicopters to MASH (Mobile Army Surgical Hospital) units. As a result, there was a further decrease in early mortality and a reduction in acute renal failure. However, a new entity termed 'shock lung' emerged as a primary cause of late death.

In 1966, a pamphlet entitled 'Accidental Death and Disability: The Neglected Disease of Modern Society' focused attention on trauma as a neglected civilian health-care issue. The work of Trunkey and others in the 1970s led to the development of regionalized trauma systems. Similar to the military experience, better organized early trauma care allowed patients to survive, who would previously have died in the field. These severely injured patients were admitted to regional trauma ICUs. In the early 1970s, the adult respiratory distress syndrome (ARDS) was described as a frequent complication. However, by the 1980s, it was recognized that patients with ARDS rarely died of isolated respiratory failure. A new syndrome called multiple organ failure (MOF) had emerged, and appeared to be the 'fatal expression of uncontrolled infection'. Over the past two decades, considerable effort has been focused on determining the pathogenesis of MOF (now called multiple organ dysfunction syndrome – MODS). By the late 1980s, it was well recognized that victims of blunt trauma frequently develop early MODS, in the absence of infection. MODS epidemiology continues to change, and pneumonia is now the most common associated infection. Timely surgical intervention, effective shock resuscitation, early stabilization of long bone fractures, avoidance of infections (principally pneumonia), and early enteral nutrition have been shown to be effective preventative strategies. As trauma care continues to improve, more high-risk patients are surviving long enough to be admitted to ICUs, only to develop MODS later. Fortunately, for reasons that are not entirely clear, the mortality of MODS is decreasing.

Title

Fluid therapy in hemorrhagic shock

Author

Shires T, Coln D, Carrico J, Lightfoot S

Reference

Arch Surg 1964; **88**: 688–693

Abstract

Not available

Summary

Using the shock preparation of Wiggers, these investigators demonstrated that the addition of plasma to shed blood resuscitation did not substantially reduce mortality (80% to 70%), but the addition of Ringer's lactate to shed blood did substantially reduce mortality (80% to 30%). In a parallel group of animals, using a triple isotope methodology, they also demonstrated that shed blood resuscitation normalized red blood cell (RBC) mass and plasma volume, but there was a 30% deficit in functional extracellular fluid (ECF) volume. Shed blood plus plasma resuscitation normalized RBC mass and increased plasma volume above control, but the same 30% ECF volume deficit remained. Shed blood plus Ringer's lactate normalized RBC mass, increased plasma volume to control levels, but normalized ECF volume. From this study and others, the authors conclude that severe hemorrhage results in a disparate reduction in ECF volume that cannot be accounted for by external loss, and that normalization of ECF volume with balanced salt solutions is associated with the best outcome.

Citation count

237

Related references

1. Rush BF, Richardson JD, Bosomworth P, Eiseman B. Limitations of blood replacement with electrolyte solutions. *Arch Surg* 1969; **98**: 49–52.
2. Carey LC, Lowery BD, Cloutier CT. Hemorrhagic shock. In: *Current Problems in Surgery*, Steichen FM (ed) Chicago: Year Book Medical Publishers, 1971.
3. Shires GT, Canizaro PC. Fluid resuscitation in the severely injured. *Surg Clin North Am* 1973; **53**: 1341–1366.

Key message

Mortality is improved in severe hemorrhagic shock when a balanced salt solution is added to shed blood replacement, compared with shed blood replacement alone, or shed blood plus plasma resuscitation.

Why it's important

This study, plus others by Shires and associates, established crystalloid resuscitation as a standard in traumatic shock.

Strengths

Laboratory study that used an established model and standard methodology.

Weaknesses

Wigger's preparation is a 'controlled' hemorrhagic shock model, which may not be relevant to the clinical scenario of early resuscitation of patients in whom bleeding has not yet been controlled.

Relevance

The current enthusiasm for the use of balanced salt solutions in the treatment of shock can in large part be attributed to the work of Shires and associates. They emphasized that severe hemorrhagic shock causes a disparate decrease in ECF volume that cannot be accounted for by external losses. They popularized the concept that a substantial portion of the unaccountable ECF is sequestered in the intracellular space (see Figure), and that effective shock resuscitation requires that it be normalized as soon as possible. This concept was supported by experiences of the treatment of casualties in the Vietnam War, where the addition of crystalloid resuscitation resulted in a decrease in early mortality and a reduction in acute renal failure. While the crystalloid versus colloid debate continues, most trauma authorities agree that albumin and artificial plasma expanders are no more effective in restoring tissue perfusion; moreover, they are prohibitively costly. Acute whole blood loss can initially be replaced with crystalloids because they replete the total extracellular space, and hemodilution enhances perfusion by reducing blood viscosity. Blood should be added to crystalloid resuscitation when the volume of crystalloids exceeds 50 ml/kg. While the suggested crystalloid replacement for blood is a ratio of 3:1, in massive shock the optimal ratio may approach 8:1.

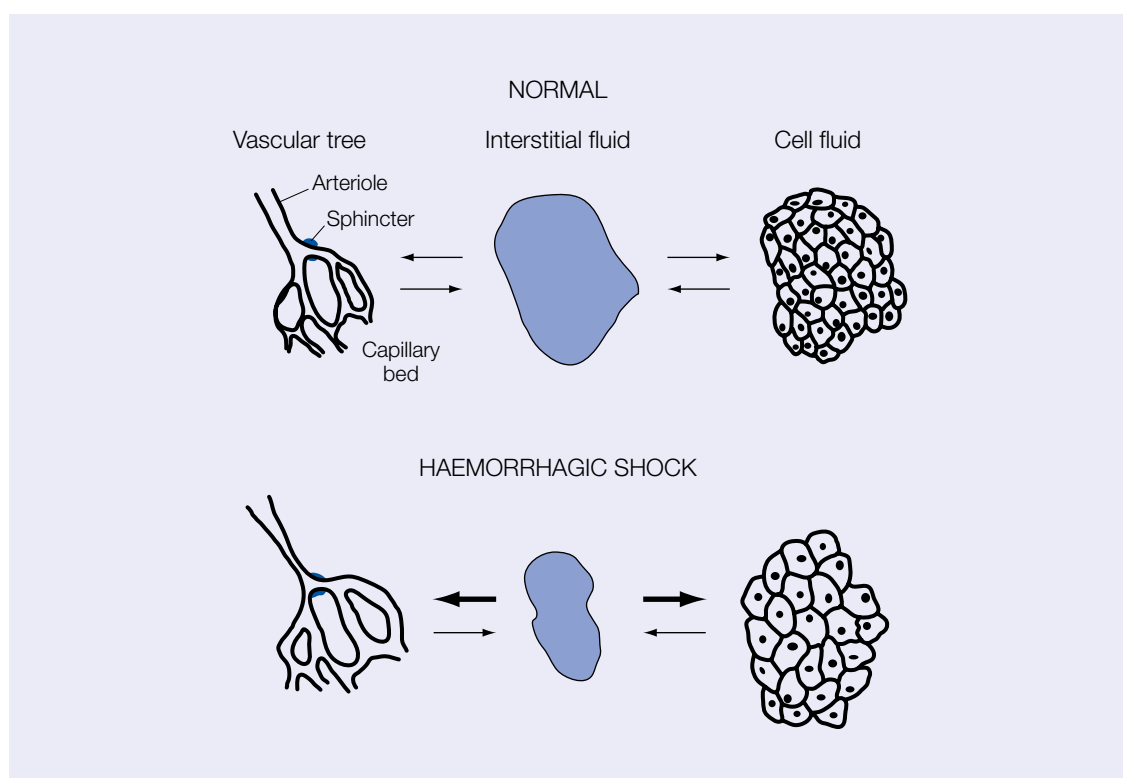

Fig. 9-1. Hemorrhagic shock causes interstitial fluid to move into both the intravascular and the intracellular space

Title

Acute respiratory distress in adults

Author

Ashbaugh DG, Bigelow DB, Petty TL, Levine BE

Reference

Lancet 1967; **2**: 319–323

Abstract

Not available

Summary

A new respiratory distress syndrome was described in 12 patients. After a variety of insults, it was manifested by acute onset of tachypnea, hypoxemia, and loss of compliance. The syndrome did not respond to usual and ordinary methods of respiratory therapy. The clinical and pathological features closely resembled those seen in infants with respiratory distress, and conditions in congestive atelectasis and post-perfusion lung. The theoretical relationship of this syndrome to alveolar surface active agent was postulated. Positive end expiratory pressure was most helpful in combating atelectasis and hypoxemia. Corticosteroids appeared to have value in the treatment of patients with fat embolism, and possibly viral pneumonia.

Citation count 1281

Related references

1. Blaisdell FW. Pathophysiology of the respiratory distress syndrome. *Arch Surg* 1974; **108**: 44–49.
2. Fulton RL, Jones CE. The cause of post-traumatic pulmonary insufficiency in man. *Surg Gynecol Obstet* 1975; **140**: 179–186.
3. Walker L, Eiseman B. The changing pattern of post-traumatic respiratory distress syndrome. *Ann Surg* 1976; **181**: 693–698.

Why it's important

Stimulated intense interest in this new entity.

Strengths

First civilian report of 'shock lung'.

Weaknesses

Retrospective case review.

Relevance

In the Vietnam War, crystalloid resuscitation was added to blood replacement. This was associated with a decrease in early mortality and a reduction in acute renal failure. However, a new entity termed 'shock lung' emerged as the primary cause of late death. This is the first report of this entity in a civilian ICU. The same authors (Thomas L. Petty and David G. Ashbaugh), in a follow-up 1972 publication, coined the descriptive term 'adult respiratory distress syndrome (ARDS)'. While the war experience suggested that aggressive crystalloid resuscitation was the primary cause, this and other studies in the early 1970s indicated that early ARDS could result from a direct insult (e.g. gastric aspiration, pulmonary contusion, near drowning), or an indirect insult (e.g. massive transfusion, fat embolism, shock). However, these patients rarely die of isolated respiratory failure, but rather succumb to late sepsis, which leads to other organ failures. The use of positive end expiratory pressure was first described in this report as a method to recruit collapsed alveoli to improve oxygenation, and was later proposed to attenuate the underlying pathogenic processes. However, clinical trials revealed this to be merely a way of buying time. Unless the inciting event could be successfully treated, and delayed infections avoided, the prognosis was grave. These early reports stimulated intense research interest that has provided considerable insight into the multiple inflammatory mediators involved in its pathogenesis. Despite this basic understanding, clinical trials testing specific therapeutic interventions have failed to document our ability to decrease the occurrence of ARDS. Fortunately, for reasons that are not clear, the mortality of post-injury ARDS appears to be decreasing.

Title

Splenic trauma in children

Author

Upadhyaya P, Simpson JS

Reference

Surg Gynecol Obstet 1968; **126**: 781–790

Abstract

Not available

Summary

Over a 10 year period ending in 1965, 52 children were admitted to the Hospital for Sick Children in Toronto with the presumed diagnosis of traumatic splenic rupture. Ten died of severe associated injuries. Another 30 underwent early laparotomy, at which time 19 were found to have no active bleeding from the spleen. The remaining 12 patients were successfully managed non-operatively. There were no cases of delayed splenic rupture.

Citation count

117

Related references

1. Ein SH, Shandling B, Simpson JS, Stephens CA. Nonoperative management of traumatized spleen in children: how and why. *J Pediatr Surg* 1978; **13**: 117–119.
2. Bond SJ, Eichelberger MR, Gotschall CS, Sivit CJ, Randolph JG. Nonoperative management of blunt hepatic and splenic injury in children. *Ann Surg* 1996; **223**: 286–289.
3. Pachter HL, Guth AA, Hofstetter SR, Spencer FC. Changing patterns in the management of splenic trauma. *Ann Surg* 1998; **227**: 708–719.

Key message

Children with isolated splenic injuries often presented with a remarkable absence of clinical signs of shock, and by the time that laparotomy was performed, splenic bleeding had stopped in the majority of cases. Most importantly, a significant subset of children with splenic injuries were successfully managed non-operatively, and in these cases, delayed splenic rupture did not occur.

Why it's important

This report provided the heretical message that splenic injuries can be successfully managed non-operatively. The authors published a better-documented follow-up study 10 years later that provided nearly identical results (1). These studies had a huge impact on the evolution of the management of blunt abdominal trauma in both children and adults.

Strengths

First study.

Weaknesses

1. Selection criteria for non-operative management were not clear.
2. Did not have radiological confirmation of splenic injury in patients treated non-operatively.

Relevance

Kocher's *Textbook of Surgery*, published in 1911, stated 'Injuries to the spleen demand excision of the gland, no evil effect will follow its removal while the danger of hemorrhage is effectively stopped'. This became surgical dogma until the 1970s, when it became apparent that the spleen had important immunological functions, and that the asplenic host was at lifelong risk for overwhelming post-splenectomy sepsis. Additionally, it had been demonstrated that the injured spleen could be salvaged by relatively simple operative techniques, and the risk of delayed bleeding was minimal. However, the pediatric surgeons at the Hospital for Sick Children in Toronto successfully championed the concept that the best way to preserve the injured spleen is to not let a surgeon operate on it. Currently, >85% of children with splenic injuries are managed non-operatively, and the reported failure rate is <5%. Non-operative management of splenic injuries has been extended into the adult population. Currently, roughly 60% of adults are managed non-operatively. The reported failure rate is higher (8–15%). With the widespread availability and refinement in computed tomography technology, non-operative management of the spleen has become the standard of care in trauma centres worldwide (see Figure). Intensive care specialists need to recognize that the pitfalls of this approach include delayed splenic bleeding, and missed hollow viscus injuries. Delayed splenic hemorrhage can be an insidious event because the injured spleen does not bleed rapidly. Missed hollow viscus injury is more common in adults, and is associated with a worse outcome if therapeutic intervention is delayed for prolonged periods (>24 h).

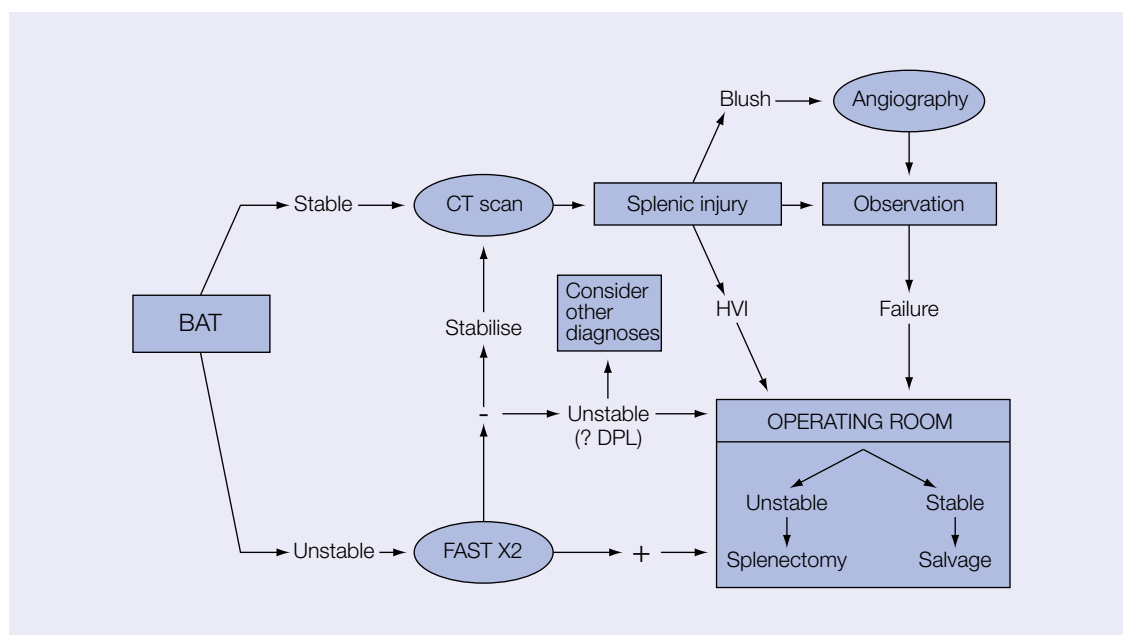

Fig. 9-2. Current algorithm for suspected blunt splenic trauma BAT, blunt abdominal trauma; CT, computed tomography; FAST, focused abdominal sonography for trauma; HVI, hollow viscus injury; DPL, diagnostic peritoneal lavage; blush, extravasation of intravenous contrast

Title

Management of flail chest without mechanical ventilation

Author

Trinkle JK, Richardson JF, Franz JL, Grover FL, Arom KV, Holmstrom FMG

Reference

Ann Thorac Surg 1975; **19**: 355–363

Abstract

The pathophysiology of flail chest is usually described only on the basis of paradoxical respiration, ignoring underlying pulmonary contusion. Two groups of comparable patients were treated either with early tracheal intubation and mechanical ventilation (Group 1), or with fluid restriction, diuretics, methylprednisolone, albumin, vigorous pulmonary toilet, and intercostal nerve blocks, ignoring the paradoxical breathing and treating only the underlying lung (Group 2). When tracheostomy and mechanical ventilation were not used, the mortality rate went from 21% to 0 ($p = 0.01$), the complication rate from 100% to 20% ($p = 0.005$), and the average hospitalization from 31.3 to 9.3 days ($p = 0.005$). We conclude that most patients with flail chest do not need internal pneumatic stabilization if the underlying lung is treated appropriately, and that tracheostomy and prolonged mechanical ventilation with a volume respirator, as practiced in most respiratory care centers, is usually a triumph of technique over judgement.

Summary

Retrospective review of 30 patients with flail chest, 19 were treated by the traditional approach of early tracheal intubation (17 had tracheostomies) and prolonged mechanical ventilation (average 23 days), compared with 11 patients who were treated with aggressive pulmonary care. Patients treated by aggressive pulmonary care had significantly fewer pneumonias (9% versus 84%), shorter hospital stays (10 days versus 32 days), and lower mortality (0% versus 21%).

Citation count 99

Related references

1. Avery EE, Morch ET, Benson DW. Critically crushed chests. *J Thorac Surg* 1956; **32**: 291–311.
2. Shackford SR, Virgilio RW, Peters RM. Selective use of ventilator therapy in flail chest injury. *J Thorac Surg* 1981; **81**: 194–201.
3. Bolliger CT, Van Eeden SF. Treatment of multiple rib fractures: randomized controlled trial comparing ventilator with nonventilator management. *Chest* 1990; **97**: 943–951.

Key message

Patients with flail chest injuries can be successfully managed by aggressive pulmonary care. Avoidance of intubation reduces the risk of secondary pneumonia that adversely affects patient outcome.

Why it's important

This approach challenged the traditional management approach of early tracheostomy and prolonged mechanical ventilation that had been the standard of care since the late 1960s.

Strengths

Convincingly demonstrated that a subset of patients can be treated without tracheal intubation and mechanical ventilation.

Weaknesses

1. Not a randomized trial, and thus prone to selection bias.
2. Aggressive pulmonary care was combined with a number of controversial therapies, including diuretics, high-dose steroids, and albumin.

Relevance

The treatment of flail chest injuries has evolved radically over the past six decades. This was not a common injury in civilians until automobiles became generally available. In the 1940s, the pathogenesis of respiratory failure was viewed to be a mechanical problem where paradoxical chest wall motion caused 'pendelluft' (i.e. the to and fro movement of air between the lungs, see Figure), and a number of different external approaches were used to stabilize the chest wall (e.g. sandbags, strapping, weighted traction devices). A 1956 case report by Avery and associates introduced the concept of early 'internal pneumatic stabilization' by controlled mechanical ventilation (1). In the 1960s and early 1970s, the debate evolved into whether to use operative stabilization instead of internal pneumatic stabilization. Unfortunately, mortality from progressive respiratory failure remained prohibitive. These early clinicians failed to appreciate that the vast majority of patients with flail chest injuries also have a pulmonary contusion (>85%), and that this plays a predominant role in the pathophysiology of respiratory failure. This study by Trinkle and associates introduced the concept of selective management of flail chest injuries. This was supported by a series of clinical studies by Shackford and associates (2), and convincingly confirmed in a prospective randomized trial by Bolliger *et al.* (3). Collectively, these studies have established that tracheal intubation and mechanical ventilation should be avoided if at all possible. Effective pain relief (e.g. patient-controlled analgesia or epidural catheters) combined with aggressive pulmonary care (e.g. mobilization, incentive spirometry, intermittent positive pressure breathing, nasotracheal suctioning) need to be implemented early in non-intubated patients to avoid the need for mechanical ventilation. Prolonged endotracheal intubation leads to contamination of contused lung, which results in pneumonias that are refractory to antibiotics.

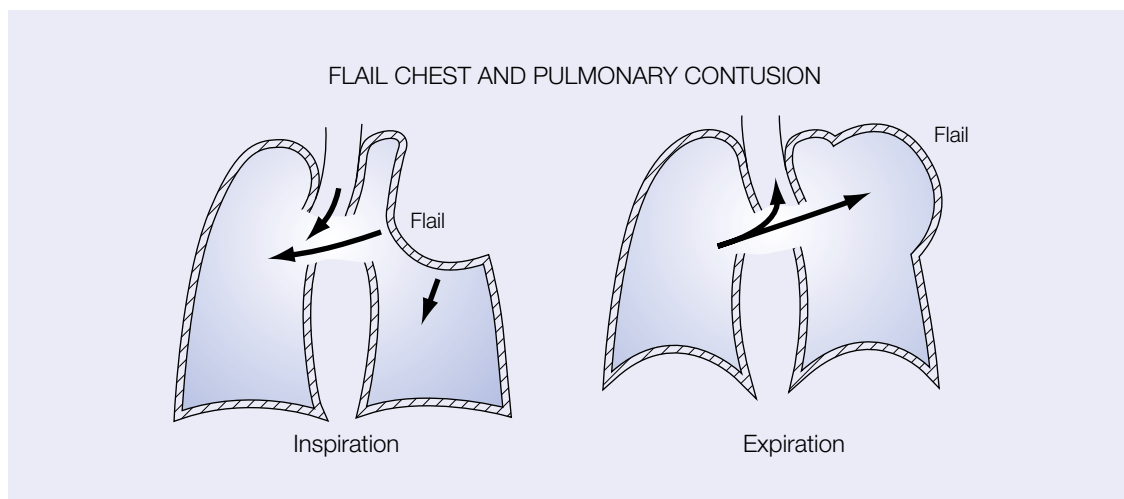

Fig. 9-3. Pendelluft is the pendulum-like movement of air from one lung to the other. The physiological significance is doubtful

Title

Epidemiology of trauma deaths

Author

Baker CC, Oppenheimer L, Stephens B, Lewis FR, Trunkey DD

Reference

Am J Surg 1980; **140**: 144–150

Abstract

Not available

Summary

A total of 437 persons died from trauma in San Francisco in 1977, of whom 285 (65%) were younger than 50 years, and 199 (27%) were between the ages of 21 and 30. Gunshot wounds (32%) and falls (28%) were the most common causes of injury. Fifty-three percent of the sample were dead at the scene of injury before transport could be accomplished, 8% died in the emergency room, and 39% died in the hospital. Fifty-five percent of the 359 patients who died within the first 2 days died from brain injury, while 78% of the 55 late deaths were due to sepsis and multiple organ failure. In 10 cases (2%), death was due to delayed transport or to errors in diagnosis and treatment and was deemed preventable. The key areas in which advances are necessary in order to reduce the number of trauma deaths are prevention of trauma, more rapid and skilled transport of injured victims, better early management of primary brain injuries, and more effective treatment of the late complications of sepsis and multiple organ failure.

Citation count

325

Related references

1. Trunkey DD, Lim RC. Analysis of 425 consecutive trauma fatalities: an autopsy study. *J Am Coll Emergency Physicians* 1974; **3**: 368–375.
2. Trunkey DD. Trauma. *Sci Am* 1983; **249**: 28–35.
3. Sauaia A, Moore FA, Moore EE *et al*. Epidemiology of trauma deaths: a reassessment. *J Trauma Injury Infect Crit Care* 1995; **38**: 185–193.

Key message

Roughly half of trauma deaths occur at the scene before transport of the patient. Prevention programmes and improved pre-hospital responses are the only ways to save these lives. Another 8% of deaths occur early, principally from exsanguinations, for which better Emergency Department response is needed. The remaining 40% of patients die later – brain injury (<48 h) and late sepsis/MOF (>7 days) are the principal causes. Better ICU care is needed in these cases.

Why it's important

This seminal report served to focus efforts on developing trauma systems to improve civilian trauma care. As a result, highly specialized burn, neurological, and shock trauma ICUs have developed in regional Level I trauma centers. This serves as a model for specialized tertiary ICU care development.

Strengths

Comprehensive epidemiological study.

Weaknesses

1. Underestimated the incidence of preventable deaths due to retrospective study design.
2. San Francisco does not reflect other geopolitical regions (e.g. high percentage of falls).

Relevance

These data were combined with data from a 1974 study to derive the data used in the classic 1983 publication by Donald Trunkey in *Scientific American* that publicized trauma as a public health problem, and described the often quoted 'trimodal distribution of trauma deaths' (see Figure). The first peak included immediate deaths (~45%) that are primarily the result of central nervous system (CNS) and major vascular trauma. The second peak included early hospital deaths (~35%) that occurred within 6 hours, principally caused by exsanguination and CNS injuries. The third peak (~20%) constituted the late deaths. Three-quarters of the late deaths were caused by sepsis-related multiple organ failure (MOF). These data were instrumental in motivating trauma system development in the USA. As a result of improved pre-hospital care and establishment of regionalized Level I trauma centres, fewer patients are now dying in the field, and more severely injured patients are surviving long enough to be admitted to the ICU. The incidence of post-traumatic MOF appears to be increasing, and, as a result of better supportive care, more of these patients are surviving to be discharged. Overall, patients who develop MOF represent a small proportion of trauma patients, but they expend an inordinate amount of ICU resources. Additionally, more severely brain-injured patients are surviving the acute post-injury period, and this has increased the need for specialized neurosurgical ICUs for the post-injury course. Unfortunately, this has increased the number of late 'brain dead' patients. This has increased the need for early declaration of futile care in patients with devastating brain injuries. Non-heart-beating organ donation has been instituted in large trauma centers to increase the retrieval of organs in these unfortunate cases.

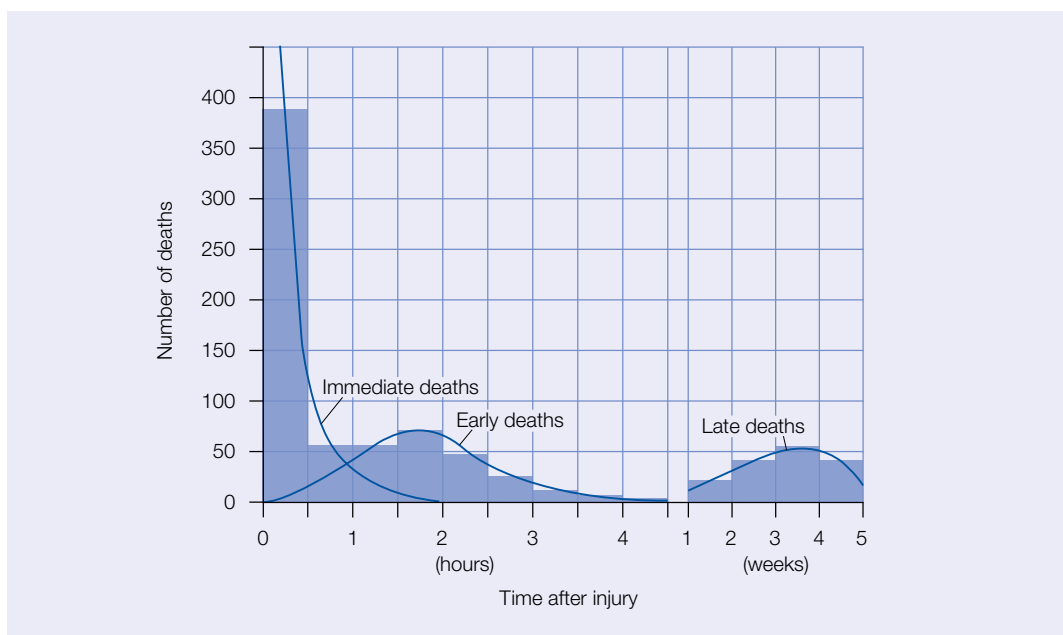

Fig. 9.4. *Trimodal distribution of trauma deaths*

Title

Multiple system organ failure

Author

Fry DE, Pearlstein L, Fulton RL, Polk HC

Reference

Arch Surg 1980; **115**: 136–140

Abstract

Multiple system organ failure (MSOF) remains a principal cause of death after major operative procedures and/or severe trauma. We studied multiple parameters in 553 consecutive emergency surgical patients to determine the incidence of MSOF, the predisposing factors to MSOF, and the sequelae of MSOF. Thirty-eight patients had MSOF; mortality was 74% for these patients. Evaluation of multiple factors demonstrated that (1) MSOF is primarily due to infection, (2) the temporal sequence of organ failure is lung, liver, gastric mucosa, and kidney, and (3) MSOF is the most common fatal expression of uncontrolled infection.

Summary

Overall, 7% of patients requiring emergency surgery (two-thirds were trauma-related) developed MSOF, of which 90% were septic, and intra-abdominal infection (IAI) was the inciting event in half of these cases.

Citation count

553

Related references

1. Eiseman R, Beart R, Norton L. Multiple organ failure. *Surg Gynecol Obstet* 1977; **144**: 323–326.
2. Faist E, Baue AE, Dittmer H *et al*. Multiple organ failure in polytrauma patients. *J Trauma* 1983; **23**: 775–782.
3. Moore FA, Sauaia A, Moore EE *et al*. Postinjury multiple organ failure: a bi-modal phenomenon. *J Trauma* 1996; **40**: 501–511.

Key message

MOSF is a relatively frequent complication following emergency laparotomy, and IAI is a frequent inciting event.

Why it's important

This report plus the related references described a new syndrome of MSOF (now called MODS) that had emerged in ICUs as a result of the ability to keep patients alive with advanced technology (1, 2). The strong and consistent epidemiological association between infection and MSOF directed trauma research efforts in the early 1980s towards determining how a traumatic insult causes infection, and how infection (principally IAI) causes remote organ injury.

Strengths

First epidemiological study of MODS.

Weaknesses

1. Non-specific definition of MODS.
2. Wrongly assumed that systemic inflammatory response syndrome (SIRS) was always caused by infection.

Relevance

This often-quoted paper stimulated a series of clinical studies that document MODS to be the leading cause of late post-injury deaths. The early studies suggested that MODS was primarily caused by uncontrolled infection. However, by the mid-1980s, it was recognized that MODS frequently occurs in the absence of infection (e.g. blunt trauma). Recent studies suggest that the mortality of MODS is decreasing (now roughly 50%), but the incidence is increasing (10–15% of trauma ICU, admissions). With the tremendous advances in trauma care, the epidemiology also appears to be changing. As a result of improved trauma systems, patients who previously died in the field are now surviving to be admitted to ICUs, and often develop early MODS independent of infection. Additionally, IAI is now a distinctly unusual inciting event for post-injury MOF. Currently there appear to be at least two different patterns of MODS (i.e. early versus late). The Figure presents the unifying hypothesis that post-injury MODS occurs as a result of a dysfunctional inflammatory response. In brief, severely injured patients are resuscitated into SIRS, which, if severe, can precipitate early MODS. As time proceeds, certain aspects of SIRS are intentionally down-regulated, which causes delayed immunosuppression, which sets the stage for late sepsis-associated MODS.

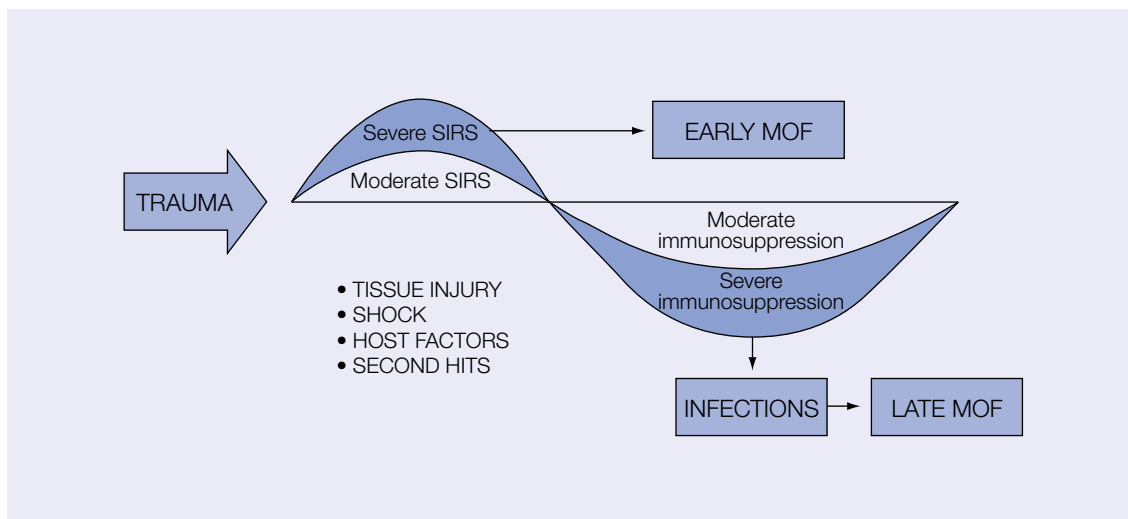

Fig. 9.5. Dysfunctional inflammation causes post-injury MOF SIRS, systemic inflammatory response syndrome; MOF, multiple organ failure

Title

Benefits of immediate jejunostomy feeding after major abdominal trauma – a prospective, randomized study

Author

Moore EE, Jones TN

Reference

J Trauma 1986; **26**: 874–881

Abstract

Seventy-five consecutive patients undergoing emergent celiotomy with an abdominal trauma index (ATI) >15 were randomized prospectively to a control group (no supplemental nutrition during first 5 days) or enteral-fed group. The enteral patients had a needle catheter jejunostomy placed at laparotomy, with the constant infusion of an elemental diet (Vivonex HN) begun at 12 hours, and advanced to 3,000 ml/day (3,000 kcal, 20 gm N) within 72 hours. Control and enteral-fed groups were comparable with respect to demographic features, injury severity, and initial nutritional assessment.

Twenty (63%) of the enteral patients were maintained on the elemental diet >5 days; four (12%) needed total parenteral nutrition (TPN). Nine (29%) of the control patients required TPN. Nitrogen balance was markedly improved ($p < 0.001$) in the enteral-fed group. Although visceral protein markers and overall complication rate were not significantly different, septic morbidity was greater ($p < 0.025$) in the control group (abdominal infection in seven and pneumonia in two), compared to the enteral-fed patients (abdominal abscess in three). Analysis of patients with ATI 15–40 disclosed sepsis in seven (26%) of the control versus one (4%) of the enteral-fed group ($p < 0.01$). Our clinical experience demonstrates the feasibility of immediate postoperative jejunal feeding after major abdominal trauma, and suggests that this early nutrition reduces septic complications in critically injured patients.

Summary

This trial was conducted to investigate the potential benefits of early post-injury nutritional support. The control group received only conventional intravenous crystalloids during the first 5 days, and then TPN was started if they could not tolerate oral intake (29% ultimately received TPN). The early fed group had jejunal feeds begun within 12 hours postoperatively. The study outcome was that the early fed patients developed significantly fewer major septic complications.

Citation count 278

Related references

1. Alexander JW, Macmillian BG, Stinnett JD *et al.* Beneficial effects of aggressive protein feeding in severely burned children. *Ann Surg* 1980; **192**: 505–517.
2. Moore FA, Moore EE, Jones TN, McCroskey BL, Peterson VM. TEN versus TPN following major abdominal trauma – reduced septic morbidity. *J Trauma* 1989; **29**: 916–922.
3. Kudsk KA, Croce MA, Fabian TC *et al.* Enteral versus parenteral feeding: effects on septic morbidity following blunt and penetrating abdominal trauma. *Ann Surg* 1992; **215**: 503–511.

Key message

High-risk abdominal trauma patients experienced reduced infectious morbidity if they received early total enteral nutrition (TEN).

Why it's important

This trial supported the earlier observations made in burned children that early high protein nutritional support (principally via the gut) reduced infectious morbidity. This study stimulated a series of clinical trials over the next decade which demonstrated that early TEN is associated with reduced infectious morbidity.

Strengths

1. The ATI was used to identify a cohort of patients who were at high risk for developing postoperative complications (principally infections).
2. Abdominal trauma patients are a relatively homogeneous group of young, predominantly male, patients free of confounding comorbid disease.

Weaknesses

1. This was a single institutional study with a small number of patients.
2. It is unclear whether these results are relevant to other patient groups.

Relevance

The role of early nutritional support in metabolically stressed patients remains a controversial topic. Despite convincing experimental data, clinical trials offer conflicting results. TPN appears to be beneficial only in severely malnourished patients. On the other hand, TEN (most recently with immune enhancing formulas) has been shown to reduce infections in previously well-nourished torso trauma patients. The exact mechanisms responsible for this difference in septic morbidity have been an enigma. Multiple factors are probably involved. First, lack of enteral nutrition may promote ongoing ileus and upper gut colonization, which could contribute to late bacterial translocation or pulmonary aspiration of contaminated gastric contents. Second, excessive administration of glucose or lipids with TPN is immunosuppressive. Third, specific nutrients (e.g. glutamine, arginine, omega-3 fatty acids, and nucleotides) directly enhance systemic immune effector cell function. Fourth, the gut is a critical immunological organ, and early gut feeding favorably modulates both local and systemic immunity.

Title

Early versus delayed stabilization of femoral fractures

Author

Bone LB, Johnson KD, Weigelt J, Scheinberg R

Reference

J Bone Joint Surg 1989; **71**: 336–340

Abstract

A prospective randomized study comparing the results of early with delayed reduction and stabilization of acute femoral fractures in adults was performed over a two-year period in 178 patients. Only patients who were more than sixty-five years old and had a fracture of the hip were excluded. Arterial blood gases, injury severity score (ISS) at the time of admission, pulmonary function, days in the hospital, days in the intensive care unit, and hospital costs were recorded for all patients. The patients were divided into two groups: those who had an isolated fracture of the femur, and those who had multiple injuries.

When stabilization of the fracture was delayed in the patients who had multiple injuries, the incidence of pulmonary complications (adult respiratory distress syndrome, fat embolism, and pneumonia) was higher, the hospital stay was longer, and the number of days in the intensive-care unit was increased. The cost of hospital care showed a statistically significant increase for all patients who had delayed treatment of the fracture compared with those who had early stabilization.

Summary

This prospective trial demonstrated that patients with femur fractures and other significant injuries (ISS >18) who were randomized to early operative stabilization (<24 h) compared with those who had late stabilization (>48 h) had less respiratory complications and shorter ICU stays. No clinical difference was noted in the patients with isolated femur fractures (ISS <18).

Citation count 266

Related references

1. Goris RJA, Gimbler JSF, vanNickerk JLM *et al.* Early osteosynthesis and prophylactic mechanical ventilation in the multitrauma patient. *J Trauma* 1982; **22**: 895–903.
2. Riska KB, Myllynen P. Fat embolism in patients with multiple injuries. *J Trauma* 1982; **22**: 891–895.
3. Seibel R, LaDuca J, Hassett JM *et al.* Blunt multiple trauma (ISS 36), femur traction, and the pulmonary failure-septic state. *Ann Surg* 1985; **302**: 283–295.

Key message

Early operative stabilization of femur fractures in patients with significant associated injuries improves outcome by decreasing pulmonary complications.

Why it's important

This trial demonstrated that early orthopedic stabilization of long bone fractures in critically injured patients improves outcome. This has become the standard of care in trauma centers worldwide.

Strengths

Prospective randomized controlled trial.

Weaknesses

Respiratory complications as an endpoint was not well defined.

Relevance

In the 1960s and 1970s, fat embolism syndrome (FES) was a major clinical problem, but today it is a rare event. In the early 1970s, long bone fractures were initially treated by traction, followed by operative intervention after the patient had stabilized. However, in the early 1980s, European studies compared with historic controls suggested that early aggressive orthopedic stabilization resulted in improvement in pulmonary function and mortality. Soon thereafter, similar observations were made in retrospective studies in the USA. This prospective randomized controlled trial convincingly confirmed these previous observations. Unfortunately, it is not clear whether the improved outcome of patients with multiple injuries is due to a decrease in FES. A more likely explanation is that early fixation of fractures permits early mobilization and participation in respiratory care protocols that have been shown to decrease the incidence of atelectasis, lobar collapse, and pneumonia. The current debate is that certain subsets of patients may be harmed by this approach. Clearly, patients who present in shock need to be 'adequately' resuscitated before operative intervention. Patients with major head injuries and high intracranial pressures may experience deleterious decreases in cerebral perfusion pressure during operative stabilization, due to general anesthesia and blood loss. Finally, there is a concern that patients with associated flail chest/pulmonary contusion may experience more acute lung injury – presumably due to increased fat embolism that occurs during intramedullary reaming or rodding.

Title

Abbreviated laparotomy and planned reoperation for critically injured patients

Author

Burch JM, Ortiz VB, Richardson RJ, Martin RR, Mattox KL, Jordan GL

Reference

Ann Surg 1992; **215**: 476–484

Abstract

The triad of hypothermia, acidosis, and coagulopathy in critically injured patients is a vicious cycle that, if uninterrupted, is rapidly fatal. During the past 7.5 years, 200 patients were treated with unorthodox techniques to abruptly terminate the laparotomy and break the cycle. One hundred seventy patients (85%) suffered penetrating injuries, and 30 (15%) were victims of blunt trauma. Resuscitative thoracotomies were performed in 60 (30%) patients. After major sources of hemorrhage were controlled, the following clinical and laboratory mean values were observed: red cell transfusions – 22 units, core temperature – 32.1°C, acid pH – 7.09. Techniques to abbreviate the operation included the ligation of enteric injuries in 34 patients, retained vascular clamps in 13, temporary intravascular shunts in four, packing of diffusely bleeding surfaces in 171, and the use of multiple towel clips to close only the skin of the abdominal wall in 178. Patients then were transported to the surgical intensive care unit for vigorous correction of metabolic derangements and coagulopathies. Ninety-eight patients (49%) survived to undergo planned reoperation (mean delay 48.1 hours), and 66 of 98 (67%) survived to leave the hospital. With the exception of intravascular shunts, there were survivors who were treated by each of the unorthodox techniques. Of 102 patients who died before reoperation, 68 (67%) did so within 2 hours of the initial procedure. Logistic regression showed that red cell transfusion rate and pH may be helpful in determining when to consider abbreviated laparotomy.

Summary

Describes the use of unorthodox techniques to terminate emergency laparotomy, so as to break the 'bloody vicious cycle' of hypothermia, acidosis, and coagulopathy.

Citation count

171

Related references

1. Moore EE. Staged laparotomy for hypothermia, acidosis and coagulopathy syndrome. *Am J Surg* 1996; **172**: 405–410.

Key message

Patients undergoing emergency laparotomy for bleeding may develop a vicious cycle of hypothermia, acidosis, and coagulopathy that, if not interrupted, is rapidly fatal. To salvage these severely injured patients, the laparotomy needs to be terminated as quickly as possible, and the patient needs to be triaged to the ICU for effective resuscitation, reversal of hypothermia, and correction of coagulopathy.

Why it's important

The so-called 'damage control' laparotomy represents the most significant advance in salvaging critically injured patients in the last decade.

Strengths

Large experience from a competent group of trauma surgeons.

Weaknesses

1. Retrospective review.
2. No standard management guidelines.

Relevance

It has long been recognized that unattended core hypothermia and persistent metabolic acidosis are key events in promoting lethal coagulopathy. This paper and other concurrent reports indicate that abbreviated laparotomy is a key maneuver to break this 'bloody vicious cycle' (see Figure) (1). This represents a significant departure from traditional surgical strategy, and is a major advance in trauma surgery that is responsible for salvaging many patients who would previously have died. It is relevant to virtually all surgeons, anesthesiologists, and critical care specialists who care for patients undergoing major surgery because its principle can be applied to any patient who is experiencing large volume bleeding. However, this approach has created an epidemic of two complications: the abdominal compartment syndrome, and the open abdomen.

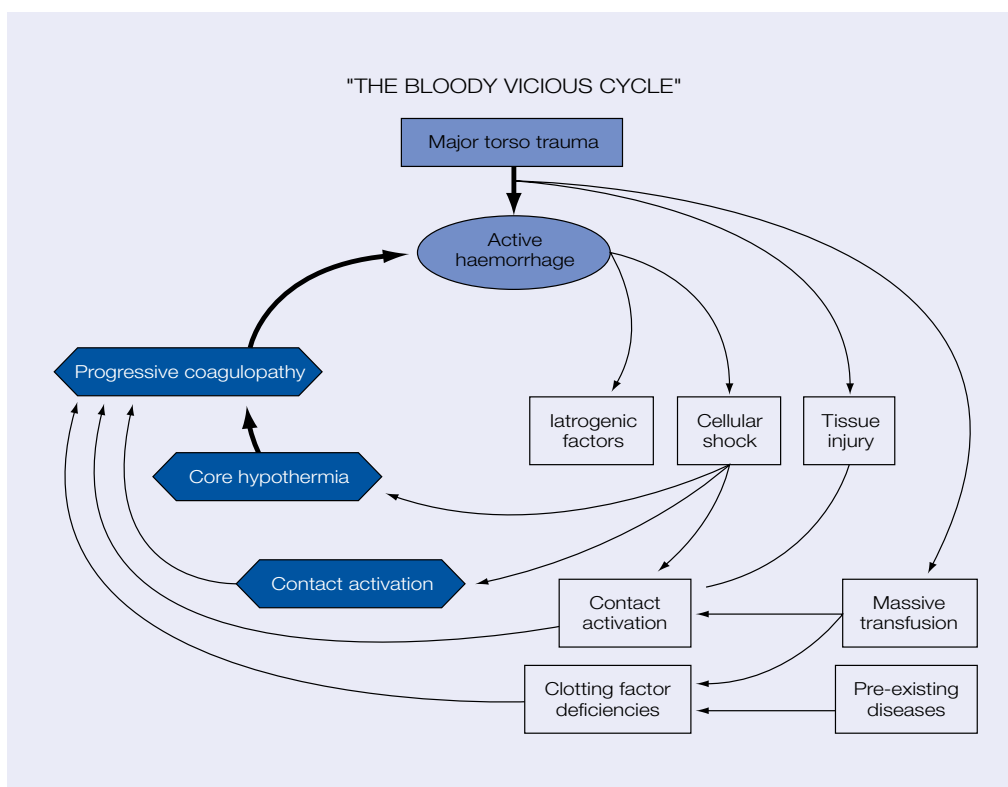

Fig. 9.6. The pathogenesis of the bloody vicious cycle following major torso trauma is multifactorial, but usually manifests as a triad of refractory coagulopathy, progressive hypothermia and persistent metabolic acidosis

Title

Immediate versus delayed fluid resuscitation for hypotensive patients with penetrating torso injuries

Author

Bickell WH, Wall MJ, Pepe PE, Martin RR, Ginger VF, Allen MK, Mattox KL

Reference

N Engl J Med 1994; **331**: 1105–1109

Abstract

The purpose of this study was to determine the effects of delaying fluid resuscitation until the time of operative intervention in hypotensive patients with penetrating injuries in the torso. A prospective trial was therefore conducted comparing immediate and delayed fluid resuscitation in 598 adults with penetrating torso injuries who presented with a pre-hospital systolic blood pressure ≤ 90 mm Hg. Patients assigned to the immediate-resuscitation group received standard fluid resuscitation before they reached the hospital and in the trauma center, and those assigned to the delayed-resuscitation group received intravenous cannulation, but no fluid resuscitation until they reached the operating room. Among the 289 patients who received delayed fluid resuscitation, 203 (70%) survived and were discharged from the hospital, as compared with 193 of the 309 patients (62%) who received immediate fluid resuscitation ($p = 0.04$). The mean estimated intraoperative blood loss was similar in the two groups. Among the 238 patients in the delayed-resuscitation group who survived to the postoperative period, 55 (23%) had one or more complications (adult respiratory distress syndrome, sepsis syndrome, acute renal failure, coagulopathy, wound infection, and pneumonia), as compared with 69 of the 227 patients (30%) in the immediate-resuscitation group ($p = 0.08$). The duration of hospitalization was shorter in the delayed-resuscitation group.

Summary

Penetrating truncal trauma patients with shock who were randomized to 'immediate resuscitation' had worse survival than patients who received 'delayed resuscitation'. Subset analysis revealed that improved survival with 'delayed resuscitation' was seen only in patients who had sustained cardiac injuries. Survival was comparable in the other subsets of patients (1).

Citation count 549

Related references

1. Wall MJ, Granchi T, Liscum K, Aucar J, Mattox KL. Delayed versus immediate fluid resuscitation in patients with penetrating trauma: subgroup analysis. *J Trauma* 1995; **39**: 173.
2. Copone AC, Safar P, Stezoski S *et al*. Improved outcome with fluid resuscitation in treatment of uncontrolled hemorrhagic shock. *J Am Coll Surg* 1995; **180**: 49–56.
3. Soucy DM, Rude M, Hsrg WC *et al*. The effects of varying fluid volume and rate of resuscitation during uncontrolled hemorrhage. *J Trauma* 1999; **46**: 209–214.

Key message

Penetrating trauma patients with active bleeding have improved outcome if aggressive volume loading is withheld until the site of bleeding has been controlled.

Why it's important

This study challenges the current standard of care as outlined in Advanced Trauma Life Support. It emphasizes an important principle, that the over-riding priority in penetrating trauma patients who are bleeding is timely surgical intervention.

Strengths

Large prospective randomized trial.

Weaknesses

1. Not blinded, and 22 of the delayed resuscitation patients were given intravenous fluids.
2. Excluded a lot of patients after randomization.

Relevance

While this clinical trial has some methodological flaws, it emphasizes an important principle that control of hemorrhage is an imperative priority in patients with penetrating trauma who present in shock. Whether resuscitation should be totally withheld until this is accomplished is doubtful. Traditional 'controlled' hemorrhagic shock models (i.e. the Wiggers preparation) have documented that if shock is allowed to persist for several hours, an irreversible shock state occurs from which the animals cannot be resuscitated. The debate is whether in settings of 'uncontrolled' hemorrhage, patients should be volume loaded to a normal blood pressure which will hemodilute and disrupt early hemostatic clots, or should volume resuscitation be withheld, which will prolong cellular shock that may become irreversible by the time surgical control is accomplished. The compromise is moderate volume loading (2, 3). A systolic blood pressure of 90 mmHg may be acceptable, but the over-riding priority needs to be timely surgical intervention. How this relates to blunt trauma is not clear. The potential of a serious associated head injury is a frequent confounding issue. It has recently been emphasized that decreased cerebral perfusion pressure will produce secondary brain injury and worsen outcome. Moreover, it generally takes a lot more time to get victims of blunt trauma to the operating room (e.g. prolonged scene times, longer transport times, more extensive emergency department evaluations), and the time to definitive control of bleeding may take hours to orchestrate (e.g. embolization of pelvic fracture, or a packed liver injury).

Clinical sepsis

David Bihari FRACP

Introduction

Clinical sepsis has been a fundamental issue in the practice of intensive care medicine since the specialty's inception in the early 1950s (1). Severe community-acquired and hospital-acquired infection presenting as clinical sepsis remain the 'bread and butter' of modern intensive care (2). Yet despite the availability of a wide range of antimicrobial agents, it continues to be associated with a high mortality (3). In the past, the term *sepsis* has caused a lot of confusion (4–7), and it is only recently that an attempt has been made to separate out the effects of microbial infection *per se* from those of the host's response (8). Lack of definitions and the problem of making a microbiological diagnosis have bedeviled the subject, making it difficult to perform controlled clinical trials in this area (9,10). Moreover, the microbiological causes of sepsis have changed in the last 50 years: the patient population treated in hospital has changed, becoming more aged, with more co-existing morbidities, and nosocomial infection with antimicrobial-resistant organisms has become a considerable problem (11). Gram-negative infection, so common on medical and surgical wards from the 1950s through to the early 1980s (12,13), has given way to both gram-positive infections – related in part to the use of more invasive procedures, more indwelling plastic, and the emergence of these hospital-acquired resistant organisms (MRSA, VRE) – and atypical infections, especially fungal sepsis, in part a consequence of the greater numbers of immunocompromised patients.

An important aspect of clinical sepsis research in the last 50 years has been the evolution of a number of concepts, all of which are relatively simplistic, and probably fundamentally flawed. Firstly, that the site and the nature of the infecting organism are of relatively minor importance (14,15); secondly, that endotoxin (16), arising either directly from gram-negative infection or as a consequence of translocation from an ischemic, leaky bowel, has a central pathogenic role (17,18); and finally, that the host response to infection often consists of an inappropriate and uncontrolled acute inflammatory reaction (with subsequent immune suppression), which is predictable, linear, and serial in nature (often being described as a 'cascade' of mediators), contributing to subsequent tissue injury (19). What is certain is that severe sepsis is the most frequent cause of multiple organ failure (MOF) in the ICU, MOF being a relatively new clinical entity arising out of our improved ability to support – but not necessarily cure – the various failing organ systems (20,21).

Perhaps rather surprisingly, the management of sepsis is relatively straightforward, and has not really changed since the introduction of antimicrobial agents >50 years ago (22). Once the diagnosis has been made – and that is where the problem often lies – pus must be drained, abscesses lanced, leaking bowel anastomoses defunctioned, dead tissue excised, and so on, so-called 'source control'. Broad-spectrum antimicrobials must be administered – *the right antibiotic at the right time in the right dose saving lives* (23–27) – and the circulation must be supported with aggressive volume replacement. Endotracheal intubation and mechanical ventilation (28) may be life-saving, as can be the judicious use of vasopressors and inotropes – but, of course, only first having corrected the state of absolute or relative hypovolemia (29). Some form of invasive hemodynamic monitoring is nearly always required in the more severe cases. Depending upon the time course of the illness, the patient may require nutritional support, delivered early and by the enteral route whenever possible, although the evidence for this intervention comes from the trauma and elective surgical literature (30). If the kidneys fail, renal replacement

therapy (RRT) may be necessary, and there is now a tendency to introduce continuous RRT in the form of bicarbonate-based hemo-filtration at a relatively early stage (31). It sounds simple, but controversies abound! For example, when and how should these patients be monitored? Are steroids indicated in some patients, and in what dose (see Schumer 1976)? What about the 'magic bullet' approach – is activated protein C really all it is cracked up to be (see Bernard *et al* 2001)? And where do the accepted principles of management come from? Are they truly 'evidence-based'? These are some of the questions that the classic papers may help us address.

Title

Shock caused by Gram-negative micro-organisms: analysis of 169 cases

Author

Weil MH, Shubin H, Biddle M

Reference

Ann Intern Med 1964; **60**: 384–400

Abstract

Not available

Summary

This is a retrospective review of 1085 patients in whom gram-negative organisms were recovered from blood cultures taken over a 4 year period (1956–1960) at the Los Angeles County Hospital. Children under the age of 5 years ($n = 349$), likely contamination of the blood culture ($n = 27$), and lack of clinical records ($n = 17$) were reasons for exclusion. Of the remaining 692 patients, 169 (24%) developed hypotension and the clinical features of shock associated with the bacteremia, and form the basis of the report. In all but 5 of these 169 patients, the systolic pressure fell below 90 mmHg, whereas in the remaining cases, all 5 of whom had pre-existing hypertension, a fall in systolic pressure of at least 50 mmHg was documented. In 77 patients, a manipulative or traumatic procedure was closely related to the onset of shock, genito-urinary procedures accounting for 82% of these precipitating events. *Escherichia coli* was the organism most commonly isolated from the blood (49% of all bacteremia with shock). Overall, 134 (79%) of these 169 shocked patients died, but survival was significantly better if a patient received a 'correct' antibiotic on the basis of in vitro sensitivity tests than when an 'incorrect' antibiotic was administered. Furthermore, there was a higher survival rate in patients receiving corticosteroids, a difference that was statistically significant in patients receiving >300 mg hydrocortisone per day. There was no evidence that survival was improved by the use of vasopressor drugs (phenylephrine, methoxamine, norepinephrine, and metaraminol), their administration being only a sign of severity. However, survival was increased in those receiving vasopressor therapy in combination with hydrocortisone, compared with those who received vasopressors alone.

Citation count 207

Related references

1. Waisbren BA. Bacteremia due to gram-negative bacilli other than the Salmonella: clinical and therapeutic study. *Arch Intern Med* 1951; **88**: 467–488.
2. Borden CW, Hall WH. Fatal transfusion reactions from massive bacterial contamination of blood. *N Engl J Med* 1951; **245**: 760–765.
3. Spink WW, Braude AI, Castaneda MR, Silva GR. Aureomycin therapy in human brucellosis due to *Brucella melitensis*. *JAMA* 1948; **138**: 1145–1148.

4. Kreger BE, Craven DE, McCabe WR. Gram-negative bacteremia. IV. Re-evaluation of clinical features and treatment in 612 patients. *Am J Med* 1980; **68**: 344–355.

Key message

This report accurately describes the clinical features of septic shock associated with gram-negative bacteremia, and the associated high mortality rate. Mortality due to bacteremia alone was 20%, but that due to bacteremia with shock rose to 78%, with a disproportionately high mortality in patients with diabetes mellitus. Survival was improved with prompt and appropriate antibiotic treatment. A significantly higher survival rate was also observed in patients who received >300 mg of hydrocortisone per day, so-called 'pharmacological' doses of steroid! In contrast, 91% of patients receiving a vasopressor succumbed.

Why it's important

This description of gram-negative septic shock clearly identifies the important risk factors for the condition and outcome – old age, urinary tract infection and manipulation of the genito-urinary tract, co-existing diabetes, and hepatobiliary disease. The study documents the importance of 'correct' antibiotic therapy, and recommends chloramphenicol, streptomycin, and tetracycline (in that order) as being the most effective. The question of treating patients with pharmacological doses of steroids is introduced, and the authors specifically reject the concept of 'subclinical adrenocortical insufficiency' as a cause of irreversibility in bacterial shock. Rather, they preferred an explanation related to the suppression of the systemic response to endotoxin, the release of which can be promoted by effective antimicrobial therapy.

Strengths

1. A very careful description of a large number of patients with a specific microbiological diagnosis, gram-negative bacteremia and shock.
2. Clear documentation of the benefit of appropriate antimicrobial therapy.
3. Introduces extremely modern concepts related to the host's response to endotoxin and the effects of steroids.
4. Raises important issues concerning the use of vasopressor agents and why they don't appear to be effective.

Weaknesses

1. Retrospective review with no case control or randomization built into the structure of the report.
2. No details concerning the use of mechanical ventilation and any form of hemodynamic monitoring or intensive care.

Relevance

This paper remains extremely relevant because it documents the effectiveness of timely antimicrobial therapy, and introduces the issue of what dose of steroid is appropriate and effective in this condition. The cut-off point of 300 mg daily of hydrocortisone that these authors identified (although they went on to recommend much higher doses in their discussion – 200 mg methylprednisolone stat plus 100 mg every 4–6 h, or 40 mg dexamethasone stat followed by 20 mg every 4–6 h) has a rather modern 'French' feel about it (see Schumer 1976)!

Title

Patterns of septic shock in man – a detailed study of 56 patients

Author

MacLean LD, Mulligan WG, McLean APH, Duff JH

Reference

Ann Surg 1967; **166**: 543–562

Abstract

Not available

Summary

This paper describes a series of 56 patients with septic shock studied within 2 hours of presentation before and then after treatment by the 'Shock Team' at the Royal Victoria Hospital, Montreal. Twenty-two patients died from their episode of shock, and an additional 12 died from other causes before discharge from hospital. Measurements included arterial (by transducer) and central venous (saline monometer) pressures, cardiac output (indocyanine green indicator dilution technique), arterial and mixed venous (right ventricular) blood gases, and arterial blood lactate. Six patients also had measurements of arterial and mixed venous oxygen contents and oxygen consumption performed. Treatment consisted of antibiotics, surgery if indicated, fluid therapy with saline and blood according to the CVP and hematocrit, so as to increase cardiac output, inotropic therapy with isoproterenol (isoprenaline) or digitalis, mechanical ventilation, steroids, and in some cases exchange transfusion and Dibenzyline. The 56 patients fell into four broad groups, depending upon abnormalities in central venous pressure and acid-base status (see Table 1). Survival was primarily related to acid-base status, with 33 of the 38 normal or alkalotic patients surviving their episode of shock, compared with only 1 of 17 acidotic patients. In 40 patients in whom serial measurements of cardiac index were available, those who were able to increase their index in response to treatment by $> 1 \text{ L/min/m}^2$ had a better prognosis (18 of the 21 survivors versus 11 of the 19 deaths). Survival was also related to whether or not surgical drainage of sepsis was possible – 15 out of 20 survivors having sepsis amenable to surgical drainage versus 16 of the 33 deaths. In these latter 16 fatal cases in which surgery was potentially useful, the source of infection was discovered late, was missed completely, or the fatal outcome was the result of inadequate surgery.

Table 10-1. Mortality rates in 56 patients with septic shock in relation to volume and acid-base status before and after treatment

Parameter	High CVP with normal or alkalotic pH		High CVP with an acidosis		Low CVP with normal or alkalotic pH		Low CVP with an acidosis	
	Before	After	Before	After	Before	After	Before	After
Survivors/patients	17/28 (61%)		0/11		5/10 (50%)		0/7	
Shock survivors	24 (86%)		1		9 (90%)		0	
Gram-negative	18		9		8		7	
Gram-positive	8		1		1		0	
Fungus	2		1		1		0	
CVP (cm H ₂ O)	12.5	10.5	13	14	3	11*	3.5	10.5*
Arterial pH	7.52	7.46	7.21	7.29	7.41	7.41	7.12	7.23
Cardiac index (L/min/m ²)	4.1	5.5	4.2	4.3	2.2	4.4*	1.9	3.0*
Total peripheral resistance (dyne.sec.cm ⁻⁵)	630	527	660	516	1377	950*	1051	570*
Lactate (mg%)	31	18*	92	125*	41	24*	48	87*
Urine output (ml/h)	17	69*	19	15	12	77*	4	32
Arterial blood pressure (mmHg)	72/40	102/57*	77/44	93/45	75/50	114/59	54/24	65/32

*Statistically significantly different from before treatment.

Table 10-2. Mortality rates in 53 patients with septic shock in relation to surgical drainage

	20 surviving patients	33 patients who died
Amenable to surgical drainage	15	16
Not amenable to surgical drainage	5	17

Citation count 318

Related references

1. Cournand A, Riley RL, Bradley SE *et al.* Studies of the circulation in clinical shock. *Surgery* 1943; **13**: 1964–1995.
2. Clowes GHR Jr, Vucinic M, Weidner MG. Circulatory and metabolic alterations associated with survival or death in peritonitis: clinical analysis of 25 cases. *Ann Surg* 1966; **163**: 866–885.
3. Siegel JH, Greenspan M, Del Guercio LRM. Abnormal vascular tone, defective oxygen transport and myocardial failure in the pathogenesis of circulatory shock. *Ann Surg* 1967; **165**: 504–517.

4. Cohn JD, Greenspan M, Goldstein CR, Gudwin AL, Siegel JH, Del Guercio LR. Arteriovenous shunting in high cardiac output shock syndromes. *Surg Gynecol Obstet* 1968; **127**: 282–288.
5. Archie JP Jr. Anatomic arterial-venous shunting in endotoxic and septic shock in dogs. *Ann Surg* 1977; **186**: 171–176.
6. Polk HC, Shields CL. Remote organ failure: a valid sign of occult intra-abdominal infection. *Surgery* 1977; **81**: 310–313.
7. Vincent J-L, Weil MH, Puri V, Carlson RW. Circulatory shock associated with purulent peritonitis. *Am J Surg* 1981; **142**: 262–270.
8. Tuchschildt J, Fried J, Astiz M, Rackow E. Elevation of cardiac output and oxygen delivery improves outcome in septic shock. *Chest* 1992; **102**: 216–220.
9. Hayes M, Timmins AC, Yau EH, Palazzo M, Watson D, Hinds CJ. Oxygen transport patterns in patients with sepsis syndrome or septic shock: influence of treatment and relationship to outcome. *Crit Care Med* 1997; **25**: 926–936.

Key message

The presentation and outcome from septic shock depended primarily upon the acid-base status of the patient at the time of diagnosis, their response to therapy, and whether or not there was a surgically treatable source of sepsis. Early septic shock may be associated with either normovolemia or hypovolemia. If recognized early while the patient is still alkalotic, both forms respond to therapy designed to maintain cardiac output at an even higher level than normal. Patients who were able to raise their cardiac output in response to therapy had a much better prognosis than those who had a lesion that could not be treated surgically.

Why it's important

This paper was one of the first to document the prognostic significance of three of the most fundamental issues in the management of a septic patient – the presence or absence of a metabolic acidosis, the effect of surgery as a form of ‘source control’ (i.e. for the eradication of a septic focus), and, finally, the response of the cardiovascular system to therapy (primarily fluids) designed to increase cardiac output. Measurements of oxygen consumption were available in only six patients. However, the authors noted that these limited data were consistent with either a defect in tissue oxygen utilization, or an inadequate microvascular blood flow accounting for an elevated arterial blood lactate. They also commented that while absolute blood flow requirements during serious illness are unknown, cardiac outputs of two to three times may be necessary to provide adequate nutrient blood flow.

Strengths

1. Single-center study in which patients were resuscitated and managed by a ‘shock team’.
2. Careful hemodynamic measurements together with arterial blood gas and acid-base assessments before and after standardized therapy. This allowed the distinction between prognostic groups based upon volumic status and acid-base balance at the time of presentation, and following their response to therapy.

Weaknesses

1. Case series with relatively poor documentation of timing of diagnosis and interventions.
2. Measurements of oxygen consumption in relation to cardiac output only given for six patients.

Relevance

The publication of this study with its excellent discussion underpins a large amount of research into the hemodynamic and oxygen transport abnormalities of sepsis that has continued over the last 35 years. The concepts outlined in the discussion remain extraordinarily relevant to practicing clinicians dealing with septic shock, and Dr MacLean's summing up in the discussion section is worthy of direct quotation:

'I think there is a danger – and I hate to admit this – in studying shock rather than the patient; and there are some who have criticized intensive care, and they may have a point when the house staff knows the arterial blood gas of a patient, but not his name ...'

Even at this early stage of development, it was clear to some that intensive care could be 'more intensive than caring' (Professor Anthony Dornhorst, 1966). This has given rise to the negative connotations associated with the clumsy, North American, and somewhat ugly term 'intensivist' – a doctor who might indeed be more intensive than caring, and not know the name of their patient!

Title

Steroids in the treatment of clinical septic shock

Author

Schumer W

Reference

Ann Surg 1976; **184**: 333–341

Abstract

A prospective (Part I) and a retrospective (Part II) study were used to determine the safety and efficacy of corticosteroids in the treatment of septic shock. In Part I, 172 consecutive patients in septic shock admitted over an 8-year period were treated with either steroid or saline: 43 received dexamethasone (DMP), 43 received methylprednisolone (MPS), and 86 received saline. The study was double-blind and randomized, and the three groups were compared for age, severity of shock, presence of underlying disease, and year of study. In the 86 saline-treated patients, the mortality rate was 38.4% (33/86); in the steroid-treated patients, it was 10.4% (9/86). With MPS, the mortality rate was 11.6% (5/43), and with DMP, it was 9.3% (4/43). Thus, overall mortality was significantly less in the steroid-treated group than in the control group. Further, there was no significant difference in mortality rate between the DMP- and the MPS-treated patients. In Part II, 328 patients were studied retrospectively. One-hundred sixty were treated without steroid, and 168 were treated with either DMP or MPS. Again, the two groups of patients were compared for severity of shock, underlying disease, age, and year of study. Mortality among patients treated without steroid was 42.5% (68/160), and among patients treated with steroid was 14% (24/168); there was no significant difference in mortality rate between DMP- and MPS-treated patients. In Parts I and II combined, complications occurred in 6% of steroid-treated patients, with no significant difference between DMP- and MPS-treated groups.

Summary

This report presents a prospective and a retrospective study of the use of steroids in septic shock in a single surgical center. The prospective study (1967–1975) included 172 patients with septic shock (86 receiving steroid – 3 mg/kg dexamethasone ($n = 43$) or 30 mg/kg methylprednisolone ($n = 43$) at the time of diagnosis, and repeated *if necessary* (my italics) after 4 hours, 86 receiving placebo (100 ml of 0.9% saline)), and was computer randomized and double blind. Septic shock was diagnosed on the basis of (1) a septic history, (2) falling blood pressure, and (3) a positive aerobic or anaerobic blood culture. Antimicrobial therapy was standardized (chloramphenicol from 1967 to 1969, followed from 1970 by a combination of gentamicin and clindamycin). Death was attributed to septic shock if the patient succumbed immediately to the shock episode, or had a continuing septic course with episodes of shock and then succumbed. Using the same diagnostic criteria, the retrospective study (a chart review over the same period of time, but with no standardization of antimicrobial therapy) consisted of 328 patients, 168 receiving steroids: 99 patients received a single bolus of 3 mg/kg dexamethasone or 30 mg/kg methylprednisolone (3 complications), whereas 69 received multiple doses (twice daily) for over 24 hours of 0.25–1.5 mg/kg dexamethasone or 10–30 mg/kg methylprednisolone (7 complications).

The mean age of the patients studied was 50 (range 22–84) and 56 (20–86) years for the prospective and retrospective studies respectively, the majority of cases being male (M:F being 167:5 and 301:27). Mortality rates are given in the table.

Mortality in steroid and placebo or non-steroid groups was related to age and underlying condition. Complication rates (5% versus 3% in the prospective study, and 6% versus 4% in the retrospective study, steroid versus non-steroid, respectively) were not significantly different, but there was a greater number of complications with prolonged, multiple dose administration of steroid in the retrospective study.

Study	Recovered	Died	Total
Prospective			
Steroid	77	9 (10.4%)	86
Saline	53	33 (38.4%)	86
Retrospective			
Steroid	124	24 (14.0%)	168
No steroids	92	68 (42.5%)	160

Citation count 350

Related references

1. Sibbald WJ, Short A, Cohen MP, Wilson RF. Variations in adrenocortical responsiveness during severe bacterial infections. Unrecognized adrenocortical insufficiency in severe bacterial infections. *Ann Surg* 1977; **186**: 29–33.
2. Sibbald WJ, Anderson RR, Reid B, Holliday RL, Driedger AA. Alveolo-capillary permeability in human septic ARDS. Effect of high-dose corticosteroid therapy. *Chest* 1981; **79**: 133–142.
3. Sprung CL, Caralis PV, Marcial EH *et al*. The effects of high-dose corticosteroids in patients with septic shock. A prospective, controlled study. *N Engl J Med* 1984; **311**: 1137–1143.
4. Bone RC, Fisher CJ, Clemmer TP, Slotman GJ, Metz CA, Balk RA and the Methylprednisolone Severe Sepsis Study Group. A controlled clinical trial of high-dose methylprednisolone in the treatment of severe sepsis and septic shock. *N Engl J Med* 1987; **317**: 653–658.
5. The Veterans Administration Systemic Sepsis Cooperative Study Group. Effect of high-dose glucocorticoid therapy on mortality in patients with clinical signs of systemic sepsis. *N Engl J Med* 1987; **317**: 659–665.
6. Bernard GR, Luce JM, Sprung CL *et al*. High-dose corticosteroids in patients with the adult respiratory distress syndrome. *N Engl J Med* 1987; **317**: 1565–1570.
7. Bollaert PE, Charpentier C, Levy B, Debouverie M, Audibert G, Larcan A. Reversal of late septic shock with supraphysiological doses of hydrocortisone. *Crit Care Med* 1998; **26**: 645–650.
8. Briegel J, Forst H, Haller M *et al*. Stress doses of hydrocortisone reverse hyperdynamic septic shock: a prospective, randomized, double-blind, single centre study. *Crit Care Med* 1999; **27**: 723–732.
9. Annane D, Sebille V, Troche G, Raphael J-C, Gajdos P, Bellissant E. A 3-level prognostic classification in septic shock based on cortisol levels and cortisol response to corticotropin. *JAMA* 2000; **283**: 1038–1104.

Key message

Numerous animal studies have shown that pharmacological doses of steroids have a beneficial effect in bacteremic and endotoxic shock. This report demonstrates a significant improvement in survival rates with either dexamethasone or methylprednisolone treatment in prospective and retrospective studies in human septic shock. The rate of complications related to high-dose steroid therapy was relatively low at 6%.

Why it's important

Following the publication of this study, it was generally accepted in North America and Europe that high-dose steroid therapy was effective in improving outcome in patients with septic shock. The clinical use of high-dose steroid therapy spilled over into the treatment of ARDS (very often associated with sepsis) and pulmonary aspiration syndromes. Subsequently, a number of large, multicenter studies were designed to test the efficacy of high-dose steroids in these settings, and the results of these trials are well known. However, there is still debate concerning the definition and incidence of relative adrenal insufficiency in severe sepsis, and whether or not physiological replacement doses of hydrocortisone are indicated in some patients, especially those requiring high-dose vasopressors.

Strengths

1. Single-center study with standardization of antimicrobial therapy and control over the use of other forms of intensive support.
2. Clear separation of the prospective (randomized and double-blind) and the retrospective studies.
3. Careful documentation of the complication rates associated with the use of high-dose steroids.

Weaknesses

1. The definition of septic shock was vague, with no details concerning what was described as a 'septic history' or a 'falling blood pressure'.
2. Mortality rates in the steroid treatment groups are difficult to understand, because they were so low (10 and 14%)! Even in the severely shocked group (>4 hours duration, markedly high lactate level, low pH, pO₂, and pCO₂, with respiratory and cardiac complications) in the prospective study (25 patients), the mortality was only 25% in the group receiving steroids, compared with 72% in the placebo group.
3. The two studies took place concurrently over 8 years, and there was no apparent improvement in survival with time. Furthermore, it was not clear why some patients were included in the prospective study and why some ended up in the retrospective study.
4. Mortality rates given are not 'all cause mortality,' rather the mortality attributable to septic shock. It is not clear at what time point – 28 days, ICU discharge, or hospital discharge – mortality rates were measured.

Relevance

The prospective study described in this report may have comprised the first randomized double-blind study performed in patients with septic shock. With the ongoing steroid debate, the relevance and historical position of this paper cannot be overlooked.

Title

Multiple organ failure

Author

Eiseman B, Beart R, Norton L

Reference

Surg Gynecol Obstet 1977; **144**: 323–326

Abstract

Forty-two postoperative patients, each with demonstrable failure of two or more vital organ systems, have been studied as they define a syndrome of multiple organ failure. They typify the emerging clinical entity of patients kept alive solely by reason of specific mechanical and pharmacologic support. Trauma initiated hospitalization in 40 percent, and major bleeding, in 11 percent. Sepsis was judged to be of etiologic significance in 69 percent. Complications in clinical management were, in retrospect, thought to be of contributory etiologic significance in 57 percent. Twenty-nine of 42 patients died; a mortality of 69 percent. Mean duration of multiple organ failure was 30.5 days. Hospital cost, omitting the physician's fees, was conservatively estimated at \$700 per day. Scientific, social, moral, ethical, and legal factors emphasize the need to establish a statistically valid large data base concerning this new man-made syndrome, which has both important scientific and social implications. This study is a first step in this direction.

Summary

This study describes the clinical course of 42 postoperative patients (mean age 50.7, range 23–86 years; 30 men), each with the demonstrable failure of two or more vital organ systems. Organ systems considered were lungs (failure of the ventilatory system requiring mechanical support), kidneys (a requirement for hemodialysis), gastrointestinal tract (bleeding stress ulcers), blood clotting, and the liver (clinical assessment and standard laboratory testing). Pre-existing disease of one of the failing organ systems was present in 23 (55%) of the 42 patients; 7 had proven hepatic cirrhosis, and 5 had significant chronic obstructive airway disease. Trauma initiated hospitalization in 17 cases (40%), major bleeding in 5 (11%), cancer in 3, and burns in 3. In the remaining 14 patients, most were hospitalized for an emergency procedure of some type. In 31 of the 42 patients, the primary disease process judged to precipitate multiple organ failure was intra-abdominal. Bacterial sepsis occurred in 29 of the 42 patients (69%), and was of etiological significance. All except 7 patients had pus in the abdomen. Complications in clinical management ('clinical error') were in retrospect thought to be of contributory etiological significance in 24 patients (57%). Multiple organ failure was surreptitious in onset, but the occurrence of respiratory and renal failure plus fever were characteristically the subtle harbingers. Mean duration of multiple organ failure was 30.5 days, and 29 of the 42 patients died, giving an overall mortality of 69%. Mean hospital charges alone during the average 30-day duration were conservatively calculated at \$21,000.

Citation count 239

Related references

1. Baue AE. Multiple, progressive or sequential systems failure. A syndrome of the 1970s. *Arch Surg* 1975; **110**: 779–781.
2. Tilney NL, Bailey GL, Morgan AP. Sequential system failure after rupture of abdominal aortic aneurysms – an unresolved problem in postoperative care. *Ann Surg* 1973; **178**: 117–122.

3. Knaus WA, Draper EA, Wagner DP, Zimmerman JE. Prognosis in acute organ failure. *Ann Surg* 1985; **202**: 685–693.
4. Beal AL, Cerra FB. Multiple organ failure syndrome in the 1990s. Systemic inflammatory response and organ dysfunction. *JAMA* 1994; **271**: 226–233.

Key message

Medical advances that permit survival despite failure of several vital organs have created a new clinical syndrome, multiple organ failure. This condition has a high mortality (70%) and a high cost of care. Scientific, social, moral, ethical, and legal factors emphasize the need to establish a statistically valid large database concerning this new man-made syndrome, which has important scientific and social implications.

Why it's important

This report of the clinical course of only 42 patients documents the central role of sepsis in the development of multiple organ failure. It also provided the first database concerning causation and survival upon which clinical decision-making could be based.

Strengths

1. Short, concise clinical report with a clear description of the syndrome of multiple organ failure.
2. Definition of organ systems in failure easy to understand.
3. Clear documentation of the central role of bacterial sepsis as the etiology in the majority of cases.
4. The recognition that the combination of respiratory and renal failure – plus fever – was the harbinger of multiple organ failure.
5. The recognition that patients with multiple organ failure are the focus of prodigious energy expenditure, be it measured in personnel, supplies, equipment, or money.
6. The recognition that there are ethical and economic issues concerning the treatment of patients with this highly lethal new syndrome.

Weaknesses

1. The lack of scoring of severity of organ failure.
2. No physiological or biochemical data provided.
3. No information provided concerning the methods of intensive support, e.g. use of vasopressors, form of mechanical ventilation, use of TPN, provided to these patients.
4. Cause of death in the patients who died was not given.

Relevance

This paper was the first to provide some meaningful data concerning the outcome of patients who develop multiple organ failure in the ICU. It led directly to Knaus's classic study of the prognosis of acute organ failure published in 1985, and has been central to the thinking of intensive care specialists over the last 20 years. Importantly, it documented the central role of sepsis in the etiology of multiple organ failure.

Title

The systemic septic response: does the organism matter?

Author

Wiles JB, Cerra FB, Siegel JH, Border JR

Reference

Crit Care Med 1980; **8**: 55–60

Abstract

The clinical and physiological responses to septicemia were evaluated in 59 patients with 70 septic episodes. All patients were critically ill, had similar ICU support, and had positive blood cultures as well as a clinical infection when studied by dye dilution cardiac outputs. The overall ratio of gram-negative to gram-positive sepsis was 2.6:1.0. Patients with septicemia caused by gram-positive organisms, gram-negative organisms, anaerobes, and fungi had similar fever, leucocyte, and acid-base responses. There were also no statistical differences in any physiological variables between organism group or between specific organisms. After volume loading, all patients exhibited a hyperdynamic cardiovascular response with abnormal vascular tone. Some degree of myocardial depression was a common feature of all forms of bacterial or fungal septicemia. Heart rate was the cardiac variable producing the increased cardiac output in this setting. The exact pathogenesis of the septic response remains undetermined. However, the response appears to be host determined and not peculiar to a specific pathogenic microorganism.

Summary

This report describes the clinical and physiological responses in 59 patients of 70 episodes of 'septicemia'. All patients (aged 40–60 years) were critically ill and managed in the ICU with similar forms of support. Fourteen episodes of gram-positive septicemia were compared to 36 episodes of gram-negative, 6 of candidemia, 5 of bacteroides, and 9 episodes with multiple organisms. Except for one transplant patient, no exogenous steroids were used. Intravascular volume (preload) was kept at a maximal level by volume loading with colloid and crystalloid. Preload was judged to be maximal when further volume expansion did not produce a significant increase in cardiac output, systemic flow being measured by indocyanine green dye dilution. Additional inotropic support (dopamine 3–5 µg/kg per min or isoproterenol (isoprenaline) 0.25–0.75 µg/min) was used when significant myocardial depression occurred. Myocardial depression was considered significant when it (*presumably cardiac output*) was associated with an oxygen consumption (VO_2) of <120 ml/min/m². Patients with severe pre-existing cardiac disease were excluded so as not to mask the hemodynamic response. Cardiac output studies were performed within 24 hours of the blood culture-proven bacteremia, those reported being the final study after volume loading, and inotropic therapy so representing the optimal 'steady state' response. When examined by group (underlying disease, site of infection) or by organism, there were no statistically significant differences in the incidence of leukopenia or leukocytosis; hyperpyrexia or hypopyrexia; and alkalosis or acidosis (either respiratory or metabolic in type). The ultimate mortality rates were 71% for gram-positive, 75% for gram-negative, 89% for multiple organisms, 20% for bacteroides, and 100% for candida. The cardiac index was usually elevated ($CI >4$ L/min/m²), and was greatest in the pneumococcal, serratia, and polymicrobial groups. Total peripheral resistance (TPR: equivalent to systemic vascular resistance) tended to be low (<1000 dyne.sec.cm⁻⁵), but VO_2 remained normal or increased. Myocardial depression occurred in all patients in all groups.

Citation count 114

Related references

1. Siegel JH, Greenspan M, Del Guercio LRM. Abnormal vascular tone, defective oxygen transport and myocardial failure in human septic shock. *Ann Surg* 1967; **165**: 504–517.
2. Blain CM, Anderson TO, Peitras RJ *et al*. Immediate haemodynamic effects of gram-negative vs. gram-positive bacteremia in man. *Arch Intern Med* 1970; **126**: 260–265.
3. Braude AI, Rock JA. The syndrome of acute disseminated moniliasis in adults. *Arch Intern Med* 1959; **104**: 91–100.
4. Opal SM, Cohen J. Clinical Gram-positive sepsis: does it fundamentally differ from Gram-negative bacterial sepsis? *Crit Care Med* 1999; **27**: 1608–1616.

Key message

In this series of patients with blood culture-positive ‘septicemia’, alterations in white blood count, fever, or acid-base balance did not differ between groups (underlying disease, site of infection), or between individual organisms. The physiological response was one of increased cardiac output, decreased total peripheral resistance (SVR), increased or normal VO_2 , increased heart rate, and myocardial depression. The response to septicemia appeared to be host-dependent rather than organism-dependent.

Why it’s important

This study was one of the first to propose that the cause and site of infection together with the nature of the infecting organism were relatively unimportant in the development of clinical sepsis and septic shock – the host’s response being much the same, at least in terms of the hemodynamic disturbance. This work led directly to the concept of the ‘sepsis syndrome’, with a devaluation of the importance of microbiological diagnosis, and set the scene for a series of unsuccessful and possibly misleading sepsis studies of the late 1980s and 1990s.

Strengths

1. Prospective study of clinical features and hemodynamic profiles of blood culture-positive clinical sepsis.
2. Clear description of volume therapy with preload judged to be maximal when further volume expansion did not produce a significant increase in cardiac output.
3. Definition of myocardial depression based upon an inadequate oxygen consumption ($<120 \text{ ml/min/m}^2$) in the presence of an optimized cardiac output.
4. Careful documentation of hemodynamic state in relation to the category of infecting organism.

Weaknesses

1. Use of the confusing term ‘septicemia’ to describe patients with blood culture-positive septic shock.
2. No details concerning the adequacy of antimicrobial therapy.
3. No serial measurements reported.

Relevance

In their discussion, the authors state clearly that the two generally accepted presentations of sepsis – the low resistance/high output state, and the low output/high resistance state, so-called ‘hot shock’ and ‘cold shock’ (hot and cold alluding to the temperature of

the peripheries) – depend on the adequacy of the patient's effective blood volume and level of myocardial function. They emphasize that there appears to be a similar defect in all forms of sepsis regardless of the microbiology.

Title

Treatment of gram-negative bacteremia and shock with human anti-serum to a mutant Escherichia coli

Author

Ziegler EJ, McCutchan JA, Fierer J, Glauser MP, Sadoff JC, Douglas H, Braude AI

Reference

N Engl J Med 1982; **307**: 1225–1230

Abstract

In an effort to decrease deaths from gram-negative bacteremia and endotoxin shock, we treated bacteremic patients with human antiserum to endotoxin (lipopolysaccharide) core. Antiserum was prepared by vaccinating healthy men with heat-killed *Escherichia coli* J5; this mutant lacks lipopolysaccharide oligosaccharide side chains, so that the core, which is nearly identical to that of most other gram-negative bacteria, is exposed for antibody formation. In a randomized controlled trial, patients were given either J5 antiserum or preimmune control serum intravenously, near the onset of illness. The number of deaths in the bacteremic patients was 42 of 109 (39 percent) in controls and 23 of 103 (22 percent) in recipients of J5 antiserum ($p = 0.011$). In those with profound shock, mortality was 30 of 39 (77 percent) in controls and 18 of 41 (44 percent) in recipients of J5 antiserum ($p = 0.003$). We conclude that human antiserum to the lipopolysaccharide core can substantially reduce deaths from gram-negative bacteremia.

Summary

This study describes a prospective, randomized, controlled, clinical trial of bacteremic patients treated with a human antiserum to endotoxin (lipopolysaccharide) core. Antisera were prepared by vaccinating healthy men with heat-killed *Escherichia coli* J5. This strain was a mutant lacking both the enzyme uridine 5'-diphosphate-galactose 4-epimerase and the ability to incorporate galactose, so that its lipopolysaccharide consisted solely of core determinants (lipid A – the toxic moiety of endotoxin, N-acetylglucosamine, 2-keto-3-deoxyoctonate, heptose, and glucose) with no side-chains. The human J5 antiserum so obtained was highly protective against *Pseudomonas* bacteremia in agranulocytic animals compared with pre-immune serum from the same human donors. The trial was conducted in seven hospitals in San Diego, San Francisco, and Lausanne over a 7-year period. Patients were considered suitable if severely ill, with recent deterioration in the form of a sudden fever or hypothermia, hypotension, or unexplained respiratory distress in which there was either good clinical evidence of an infection caused by gram-negative bacteria, or an underlying disease predisposing to gram-negative infection. The dose given was the serum (about 200 ml) obtained from one unit of blood either before (placebo) or 2 weeks after immunization (or 3 ml/kg in children). While 304 patients were included in the trial, the efficacy analysis included only 212 patients (103 receiving J5 antiserum, and 109 receiving non-immune serum), of whom 191 patients had gram-negative bacteremia confirmed by blood culture, and 21 others in whom gram-negative bacteria were isolated from infected foci. The effect of J5 antiserum on mortality is given in the table below (deaths/totals and the mortality rate). In the 80 patients with profound shock, there was a strong protective trend with respect to J5 antibody titer, mortality being 53% in the 53 patients with a hemagglutination antibody titer $>1:8$, compared with 74% mortality in the 27 patients with titers of $\leq 1:8$ ($p = 0.07$).

Table 10-3. Effect of J5 antiserum on mortality (deaths/totals and mortality rate)

Patient groups	Non-immune serum	J5 antiserum	p value
All patients included in efficacy analysis	42/109 (39%)	23/103 (22%)	0.011
With cancer	17/49 (35%)	6/35 (17%)	0.077
With neutropenia	13/41 (32%)	5/29 (17%)	0.179
Without neutropenia	29/68 (43%)	17/74 (23%)	0.012
With hypotension	38/74 (51%)	21/71 (30%)	0.008
In profound shock*	30/39 (77%)	18/41 (44%)	0.003
Positive blood cultures	38/100 (38%)	22/91 (24%)	0.041
Hypotension	34/66 (52%)	20/62 (32%)	0.028
Profound shock*	26/34 (76%)	17/37 (46%)	0.009
Negative blood cultures	4/9 (44%)	1/12 (8%)	0.080

*Requiring pressors for >6 hours.

Citation count 772

Related references

1. Baumgartner JD, Glauser MP, McCutchan JA *et al.* Prevention of gram-negative shock and death in surgical patients by antibody to endotoxin core glycolipid. *Lancet* 1985; **ii**: 59–63.
2. Ziegler EJ, Fisher CJ, Sprung CL *et al.* and the HA-1A Sepsis Study Group. Treatment of gram-negative bacteremia and septic shock with HA-1A human monoclonal antibody against endotoxin. A randomized, double-blind, placebo-controlled trial. *N Engl J Med* 1991; **324**: 429–436.
3. Greenman RL, Schein RM, Martin MA *et al.* and the XOMA Sepsis Study Group. A controlled clinical trial of E5 murine monoclonal IgM antibody to endotoxin in the treatment of gram-negative sepsis. *JAMA* 1991; **266**: 1097–1102.
4. Wortel CH, von der Mohlen MA, van Deventer SJ *et al.* Effectiveness of a human monoclonal anti-endotoxin antibody (HA-1A) in gram-negative sepsis: relationship to endotoxin and cytokine levels. *J Infect Dis* 1992; **166**: 1367–1374.
5. Quezado ZM, Natanson C, Alling DW *et al.* A controlled trial of HA-1A in a canine model of gram-negative septic shock. *JAMA* 1993; **269**: 2221–2227.
6. McCloskey RV, Straube RC, Sanders C, Smith SM, Smith CR and the CHESS Trial Study Group. Treatment of septic shock with human monoclonal antibody HA-1A. A randomized, double-blind, placebo-controlled trial. *Ann Intern Med* 1994; **121**: 1–5.
7. The National Committee for the Evaluation of Centoxin. The French National Registry of HA-1A (Centoxin) in septic shock. A cohort study of 600 patients. *Arch Intern Med* 1994; **154**: 2484–2491.
8. Bone RC, Balk RA, Fein AM *et al.* and the E5 Sepsis Study Group. A second large controlled clinical study of E5, a monoclonal antibody to endotoxin: results of a prospective, multicentre, randomised, controlled trial. *Crit Care Med* 1995; **23**: 994–1006.
9. Angus DC, Birmingham MC, Balk R *et al.* E5 murine monoclonal antiendotoxin antibody in gram negative sepsis: a randomised controlled trial. *JAMA* 2000; **283**: 1723–1730.

Key message

These results suggest that human J5 antiserum substantially lowers mortality from gram-negative bacteremia and septic shock. Protection was evident even when serum was combined with the best available antimicrobial, pressor, and surgical treatment.

Why it's important

These observations confirmed the realistic therapeutic potential of antiserum to lipopolysaccharide-core determinants, and also provided strong support for the hypothesis that endotoxin was the lethal factor in gram-negative bacteremia. This work led directly to the development of monoclonal antibodies against endotoxin, and hence a number of negative clinical trials.

Strengths

1. Prospective, randomized, double-blind controlled clinical trial in several centers.
2. Human antiserum carefully tested in animals and shown to be protective in a number of animal models of gram-negative sepsis.
3. Treatment and placebo groups well balanced in terms of bacterial isolates from blood culture, source of gram-negative sepsis, underlying conditions, and factors with a poor prognosis (prevalence of gram-negative pneumonia, *Pseudomonas* bacteraemia, hypotension, and profound shock).

Weaknesses

1. The study took place in seven centers over 7 years, yet recruited only 304 patients. No details are provided concerning whether or not these were consecutive cases, and how many patients with gram-negative sepsis were missed.
2. The inclusion criteria are vague and imprecise. Exclusion criteria are not given.
3. No details of other supportive therapies (fluid resuscitation, vasopressors, use of mechanical ventilation) are provided.
4. The analysis is an 'efficacy' analysis, excluding 92 patients who did not have gram-negative bacteremia or in whom gram-negative organisms were not obtained from a likely infecting source. No intention to treat analysis is provided.
5. The time points of the measurement of mortality and the causes of death are not given.

Relevance

The publication of this paper defines the beginning of the 'anti-endotoxin' era that peaked with the Ziegler publication concerning HA-1A ('Centoxin', Centacor) in 1991 but then crashed and burned. Together with the steroid studies, it also marked the beginning of the 'magic bullet' approach to therapy that was in marked contrast to the ongoing parallel clinical research into the physiological disturbances (delivery-dependent oxygen consumption, lactate production) – and their correction (fluids, vasopressors, and so on) – associated with sepsis.

Title

Profound but reversible myocardial depression in patients with septic shock

Author

Parker MM, Shelhamer JH, Bacharach SL, Green MV, Natanson C, Frederick TM, Damske BA, Parrillo JE

Reference

Ann Intern Med 1984; **100**: 483–490

Abstract

To characterize the role of cardiac function in septic shock, serial radionuclide cineangiographic and hemodynamic evaluations were done on 20 patients with documented septic shock. Although all patients had a normal or elevated cardiac index, 10 patients had moderate to severe depression of their ejection fraction with values below 0.40. Thirteen of twenty patients survived their episode. Paradoxically, 10 of 13 survivors, but none of the seven nonsurvivors, had an initial ejection fraction less than 0.40 ($p < 0.005$). The mean initial ejection fraction for the survivors was 0.32 ± 0.04 , and their mean end systolic and end diastolic ventricular volumes were substantially increased with a normal stroke volume. The survivors' serial scans showed a gradual return to normal ejection fraction and ventricular volume by 10 days after the onset of shock. Nonsurvivors had normal initial ejection fractions and ventricular volumes that did not change during serial studies.

Summary

This paper describes a series of 20 patients (mean age 43.6 years, range 9–64) studied in the ICU of the National Institutes of Health in an attempt to characterize the role of myocardial depression in septic shock. All patients had a fever ($>38^{\circ}\text{C}$) and hypotension (mean arterial pressure <60 mmHg), and 17 had positive blood cultures (10 patients with a gram-negative bacteremia, 3 with a gram-positive bacteremia, 2 with a mixed bacteremia, and 2 with candidiasis). The remaining 3 cases had a severe neutropenia ($<500/\text{mm}^3$) and a culture-positive localized site of infection; their blood cultures were negative but they were receiving broad-spectrum antimicrobial agents at the time. Invasive hemodynamic monitoring (arterial and pulmonary arterial catheterization) was used in all cases, and left ventricular ejection fraction (LVEF) was measured serially by ECG-gated cardiac scintigraphy (portable Gamma camera, repeated injections of stannous pyrophosphate and 20 mCi of technetium-99m to label the patients' red cells in vivo). From the LVEF and the thermodilution-derived measurements of stroke volume index (cardiac index/heart rate), left ventricular end-diastolic and end-systolic volumes were calculated. A standard protocol was used to treat all patients to maintain a MAP >60 mmHg. Initially, the patients received fluid loading to maintain a pulmonary arterial occlusion pressure of 12–15 mmHg, followed by vasopressor therapy with dopamine up to $20 \mu\text{g}/\text{kg}/\text{min}$. Levarterenol (noradrenaline) was then added if the MAP remained <60 mmHg, the dopamine being tapered back to $2\text{--}5 \mu\text{g}/\text{kg}/\text{min}$. Broad-spectrum antimicrobial agents (aminoglycoside + cephalosporin + anti-pseudomonal penicillin) were administered, and two doses of $30 \text{ mg}/\text{kg}$ of methylprednisolone were also given. Fifteen patients required mechanical ventilation. Thirteen patients survived their episode of septic shock, whereas 7 died of refractory hypotension. Ten of the 13 surviving patients had an initial LVEF of <0.40 (the normal range being 0.54 ± 0.01 , obtained from 32 control patients with normal cardiac function and not in shock), whereas all seven non-survivors had an LVEF >0.45 . Thus, paradoxically, a low initial ejection fraction was associated with survival.

Table 10-4. Summary of results of study

Parameter	Survivors (13)	Deaths (7)
Cardiac index (L/min/m ²)		
Initial	4.1 ± 0.4	5.4 ± 0.7
4-day average	3.9 ± 0.4	5.3 ± 0.8
Stroke volume index (ml/beat/m ²)		
Initial	40 ± 4	43.4 ± 4.1
4-day average	no change	no change
Systemic vascular resistance index (dyne.sec.cm ⁻⁵ .m ⁻²)		
Initial	1159 ± 168	1127 ± 159
4-day average	1611 ± 133	1109 ± 147*
Left ventricular ejection fraction (%)		
Initial	0.32 ± 0.04	0.55 ± 0.03
After 4–7 days	0.55 ± 0.05 [†]	no change until death
4-day average	0.33 ± 0.04	0.55 ± 0.03 [†]
Left ventricular end-diastolic volume (ml/m ²)		
Initial	159 ± 29	81 ± 9
After 4–7 days	72 ± 12 [§]	no change until death

*p < 0.05, [†]p < 0.005 survivors compared with patients who died; [‡]p < 0.005, [§]p < 0.05 initial values compared with values obtained after 4–7 days.

Citation count 553

Related references

1. Wiggers CJ. Myocardial depression in shock: a survey of cardiodynamic studies. *Am Heart J* 1947; **33**: 633–650.
2. Lefer AM, Martin J. Origin of myocardial depressant factor in shock. *Am J Physiol* 1970; **218**: 1423–1427.
3. Calvin JE, Driedger AA, Sibbald WJ. An assessment of myocardial function in human sepsis utilizing ECG gated cardiac scintigraphy. *Chest* 1981; **80**: 579–586.
4. Parrillo JE, Burch C, Shelhamer JH, Parker MM, Natanson C, Schuette W. A circulating myocardial depressant substance in humans with septic shock. *J Clin Invest* 1985; **76**: 1539–1553.
5. Cunnion RE, Schhaer GL, Parker MM, Natanson C, Parrillo JE. The coronary circulation in human septic shock. *Circulation* 1986; **73**: 637–644.
6. Dhainaut JF, Huyghebaert MF, Monsallier JF *et al.* Coronary hemodynamics and myocardial metabolism of lactate, free fatty acids, glucose, and ketones in patients with septic shock. *Circulation* 1987; **75**: 533–541.
7. Parker MM, Shelhamer JH, Natanson C, Alling DW, Parrillo JE. Serial cardiovascular variables in survivors and non-survivors of human septic shock. *Crit Care Med* 1987; **15**: 923–929.
8. Kumar A, Thota V, Dee L, Olson J, Uretz E, Parrillo JE. Tumor necrosis factor alpha and interleukin 1 beta are responsible for in vitro myocardial cell depression induced by human septic shock serum. *J Exp Med* 1996; **183**: 949–958.

9. Kumar A, Brar R, Wang P *et al.* Role of nitric oxide and cGMP in human septic serum-induced depression of cardiac myocyte contractility. *Am J Physiol* 1999; **276** (1 Pt 2): R265–R276.

Key message

Significant myocardial depression as shown by decreased ejection fraction and ventricular dilatation frequently can occur early in septic shock, even in the presence of a normal or elevated cardiac output. Furthermore, if the patient survives, this myocardial depression is reversible over a period of 7–10 days. Acute dilatation in survivors enables them to maintain a normal stroke volume in the face of a reduced ejection fraction, reflecting a loss of myocardial contractility. Non-survivors may have stiffer hearts, related to a greater generalized capillary leak, and more severe myocardial edema, and hence the lack of dilatation. Stroke volume was maintained in this group because of the lower after-load reflected in the lower systemic vascular resistance, despite higher doses of vasopressors.

Why it's important

This paper's importance is related to the authors' novel application of nuclear imaging technology at the ICU bedside, and their surprising findings. Previously, the myocardial depression associated with sepsis was thought to be manifest as a hypodynamic, low cardiac output state, so-called 'cold shock'. However, eventually it became clear that a high cardiac output was typical of normovolemic or resuscitated septic shock (see the second paper in this chapter). Nevertheless, hyperdynamic 'hot shock' was thought to progress to 'cold shock', and hence to a fatal outcome. Parker and colleagues were the first (and the last!) to be able to demonstrate the existence of human septic myocardial depression as manifested by biventricular dilatation and depression of the left ventricular ejection fraction, this dilatation being more obvious in patients who subsequently survived.

Strengths

1. Single-center study of 20 patients, of whom 17 had positive blood cultures.
2. Standardized resuscitation protocol guided by invasive hemodynamic monitoring.
3. A control group of patients (22 with malignancies and 10 without) was included to obtain a normal range for LVEF and LVEDV.
4. Autopsies were performed on six of the seven deaths due to refractory hypotension. Five of these non-survivors had no coronary artery disease, and the sixth had an adequately bypassed coronary stenosis.

Weaknesses

1. Primarily a study of gram-negative (12/17) and fungal (2/17) sepsis in a young (mean age 44 years, with 8 patients being younger than 40), immune suppressed (underlying disease being malignancy in 15 cases) population.
2. Gram-positive organisms were responsible for the septic shock in only three cases (one *Clostridium* sp., one alpha-streptococcus, one *Staphylococcus aureus*).
3. No other measures of left ventricular function, e.g. response to volume loading, were reported other than ejection fraction.

Relevance

It is obviously a truism to state that when a patient dies from septic shock, their cardiac output falls away until eventually the heart stops. Parrillo's group at the NIH had the opportunity to study a selected population of patients, who were young with healthy cardiovascular systems. It seems that in this population, non-survivors had a lower systemic vascular resistance than survivors, presumably reflecting more severe, vasodilating

disease. This was associated with a greater cardiac output in a compensatory attempt to maintain mean arterial pressure. A simple explanation for the greater left ventricular ejection fractions in non-survivors was a significantly lower after-load. However, the authors preferred to emphasize an apparent reduction in ventricular compliance in this group, perhaps related to a more severe capillary leak and worse myocardial edema. Their observations were somewhat unexpected, and have never been confirmed in a broader population of patients, but brought into focus myocardial diastolic dysfunction in sepsis – a stiff, non-compliant heart that may be relatively under-filled for a given filling pressure. The other important message of this study is the potential danger of raising after-load in patients with myocardial dysfunction in whom ejection fraction is already reduced, or at least only maintained as a consequence of vasodilatation. The excess death rate in the treatment arm of the large Glaxo-Wellcome phase III study of 546C88 (mono-methyl arginine, L-NMMA), a non-specific inhibitor of NO synthase, may well be explained by intense vasoconstriction worsening myocardial function and dropping cardiac output.

Title

Fluid loading increases oxygen consumption in septic patients with lactic acidosis

Author

Haupt MT, Gilbert EM, Carlson RW

Reference

Am Rev Respir Dis 1985; **131**: 912–916

Abstract

We prospectively evaluated 20 patients with systemic sepsis and signs of circulatory failure to determine if fluid loading was associated with increases in systemic oxygen delivery (DO_2) and consumption (VO_2). Fluid loading led to an increase in DO_2 in 14 patients (70%). Patients who demonstrated increased DO_2 with a corresponding increase in VO_2 (Group A, $n = 8$) had significantly higher ($p < 0.05$) initial blood lactate levels (4.9 ± 2.9 mmol/L, mean \pm SD) than did patients without an increase in VO_2 (Group B, $n = 6$, 1.9 ± 1.0 mmol/L). A decrease in DO_2 that was attributed to hemodilution was noted in the remaining 6 patients (Group C). Group C exhibited elevated lactate levels (5.1 ± 2.4 mmol/L) and no significant changes in VO_2 . We conclude that lactic acidosis, a marker of anaerobic metabolism, predicts increases in VO_2 in septic patients who respond to fluid loading with an increase in DO_2 .

Summary

Because sepsis is characterized by increased microvascular permeability and by fluid shifts from the intravascular to the extravascular space, an important therapeutic goal is to replace intravascular volume deficits with supplemental fluids. This study prospectively evaluated 20 patients with systemic sepsis, which was defined as more than two of the following four criteria: (1) clinically identified site of infection, (2) positive cultures of blood or fluid from the primary site, (3) fever, or (4) leukocytosis – together with signs of circulatory failure (systolic BP < 90 mmHg, heart rate > 100 beats/min, and/or urine output < 20 ml/h). The aim was to determine whether or not fluid loading was associated with an increase in systemic oxygen delivery (DO_2) and consumption (VO_2). Cardiac output with the calculated arterial and mixed venous blood oxygen contents (obtained from the measured pO_2 , saturation and hemoglobin concentration) were obtained before fluid administration, and then after every 250-ml aliquot of colloid (6% hydroxyethyl starch or 5% human serum albumin), until either a maximal cardiac output was reached, or the pulmonary artery wedge pressure exceeded 20 mmHg. Patients were excluded from the study if fluid loading failed to increase the cardiac output. Based upon the response of DO_2 and VO_2 to fluid loading, patients were divided into three groups – group A, who increased both their DO_2 and their VO_2 , group B, who increased their DO_2 , but in whom there was no change or a fall in VO_2 , and group C, in whom fluid loading resulted in a decreased DO_2 (Table). Fluid loading resulted in an increase in DO_2 in 14 of the 20 patients (groups A and B), but only in 8 patients (group A) was this accompanied by an increase in VO_2 . In the other 6 patients (group B), there was actually a small fall in VO_2 that was statistically significant. Initial lactate levels were significantly higher in group A compared with group B. In contrast, VO_2 did not change in the 6 group C patients who also had high lactate levels, but in whom there was a reduction in DO_2 with fluid loading.

Table 10-5. Summary of study findings

Parameter	Group A (n = 8)		Group B (n = 6)		Group C (n = 6)	
Age (years)	68±13		74±11		62±24	
Fluid volume (ml)	750±327		875±468		792±368	
Survival at:						
24 hours	6 (75%)		3 (50%)		5 (83%)	
hospital discharge	5 (63%)		3 (50%)		2 (33%)	
	Initial	Final	Initial	Final	Initial	Final
HR (beats/min)	107±20	103±18	101±18	92±21	112±20	105±15
PAOP (mmHg)	10±5	17±6*	8±4	14±5*	11±6	15±4*
MAP (mmHg)	74±15	87±24 [†]	69±14	82±11	68±11	77±14 [†]
CI (L/min/m ²)	3.59±1.3	4.42±1.4 [†]	3.62±0.6	4.72±1.1 [†]	3.80±1.3	4.25±1.2 [†]
DO ₂ (mL/min/m ²)	525±166	577±184 [†]	512±84	555±78 [†]	518±180	475±160 [†]
VO ₂ (mL/min/m ²)	143±16	167±15 [†]	143±33	128±24*	146±35	132±23
Lactate (mmol/L)	4.9±2.9 [‡]	4.4±2.1	1.9±1.0	1.9±1.0	5.1±2.4	3.4±1.5

*p <0.05, †p <0.01 for initial to final values; ‡p <0.05 compared with group B (initial values).

Citation count 206

Related references

1. Powers SR Jr, Mannal R, Neclerio M *et al.* Physiologic consequences of positive end-expiratory pressure (PEEP) ventilation. *Ann Surg* 1973; **178**: 265–272.
2. Cain SM. Oxygen delivery and uptake in dogs during anaemic and hypoxic hypoxia. *J Appl Physiol* 1977; **42**: 228–234.
3. Danek SJ, Lynch JP, Weg JG, Dantzker DR. The dependence of oxygen uptake on oxygen delivery in the adult respiratory distress syndrome. *Am Rev Respir Dis* 1980; **122**: 387–395.
4. Shibutani K, Komatsu T, Kubal K, Sanchala V, Kumar V, Bizzarri DV. Critical level of oxygen delivery in anaesthetised man. *Crit Care Med* 1981; 640–643.
5. Gilbert EM, Haupt MT, Mandanas RY, Huaranga AJ, Carlson RW. The effect of fluid loading, blood transfusion and catecholamine infusion on oxygen delivery and consumption in patients with sepsis. *Am Rev Respir Dis* 1986; **134**: 873–887.
6. Bihari D, Smithies M, Gimson A, Tinker J. The effects of vasodilatation with prostacyclin on oxygen delivery and uptake in critically ill patients. *N Engl J Med* 1987; **317**: 397–403.
7. Shoemaker WC, Appel PL, Kram HB, Waxman K, Lee TS. Prospective trial of supranormal values of survivors as therapeutic goals in high-risk surgical patients. *Chest* 1988; **94**: 1176–1186.

8. Shoemaker WC, Appel PL, Kram HB. Tissue oxygen debt as a determinant of lethal and non-lethal postoperative organ failure. *Crit Care Med* 1988; **16**: 1117–1120.
9. Boyd O, Grounds RM, Bennett ED. A randomized clinical trial of the effect of deliberate perioperative increase of oxygen delivery on mortality in high-risk surgical patients. *JAMA* 1993; **270**: 2699–2707.
10. Wilson J, Woods I, Fawcett J *et al*. Reducing the risk of major elective surgery: randomised controlled trial of preoperative optimisation of oxygen delivery. *BMJ* 1999; **318**: 1099–1103.

Key message

This study demonstrated that in septic patients, elevated lactate levels – a marker, in the main, of tissue hypoxia – predicted an increase in oxygen consumption (VO_2) in response to an increase in arterial oxygen delivery (DO_2) that was produced by fluid loading. In contrast, but consistent with this finding, was the observation that a normal lactate predicted independence (the normal physiological relationship between these two variables at rest) between DO_2 and VO_2 . Fluid loading thus remained an effective means to increase DO_2 in patients with sepsis, providing that hemodilution was avoided.

Why it's important

There are no randomized studies of fluid resuscitation in sepsis, but the view that volume loading – after effective antimicrobial therapy – is perhaps the most important intervention in the treatment of serious sepsis and septic shock depends upon anecdotal reports of response to fluids, and these surrogate outcome studies. There is considerable evidence in the literature that lactic acidosis in septic shock is associated with a poor outcome, that fluid therapy in some septic patients markedly increases their cardiac output and that a response (an increase in cardiac output, and a fall in blood lactate level) to fluid therapy is associated with a greater rate of survival. This study, by its emphasis on the presence of a lactic acidosis predicting an abnormality in the VO_2/DO_2 relationship that might be corrected by fluid therapy, provides more evidence for the primary importance of fluid resuscitation in sepsis. The only other support for the importance of fluid resuscitation comes from the peri-operative 'optimization' studies, but, of course, these studies were not primarily related to sepsis.

Strengths

1. Single-center study of 20 patients performed with great care and attention to detail.
2. Good discussion of the appropriate treatment of sepsis.
3. Focus on fluid resuscitation.

Weaknesses

1. Observational study with no randomization of any form.
2. Only 20 patients recruited over a 28-month period in a large American teaching institution (Detroit Receiving Hospital), suggesting some form of patient selection.
3. Relatively weak criteria for the diagnosis of sepsis based on more than two of the following: clinically identified site of infection, positive cultures of blood or fluid from primary sites, fever, or leukocytosis.

Relevance

Nowadays, the role of endotoxin and the other mediators of the inflammatory response (cytokines, proteases, oxygen free radicals, nitric oxide, tissue factor, and thrombin) is emphasized in the development of the tissue injury associated with serious sepsis and septic shock. In contrast, there are those who are old-fashioned enough to prefer to focus on the importance of microcirculatory blood flow and the avoidance or correction of tissue hypoxia as the critical issue in the prevention of multiple organ failure. This study put the focus on the importance of fluid therapy.

Title

Association between tumour necrosis factor in serum and fatal outcome in patients with meningococcal disease

Author

Waage A, Halstensen A, Espevik T

Reference

Lancet 1987; i: 355–357

Abstract

Serum samples taken on admission from 79 patients with meningococcal meningitis, septicemia, or both, were examined in a highly sensitive bioassay for tumor necrosis factor (TNF). TNF was detected in samples from 10 of 11 patients who died, but from only 8 of 68 survivors. All 5 patients with serum TNF levels over 440 units/ml (corresponding to 0.1 ng/ml recombinant TNF) died.

Summary

Using a bioassay based on a cell line sensitive to the cytotoxic effects of recombinant tumor necrosis factor (TNF), the authors studied 79 patients (43 male, 36 female; aged 1–93 years) with meningococcal disease admitted to two university hospitals in Norway. All patients with available admission serum samples were included. The clinical diagnosis of meningococcal disease was confirmed bacteriologically (71 patients) or serologically (8 patients), the majority (56/64) of isolates of *Neisseria meningitidis* tested being serogroup B. A patient serum sample was regarded as TNF-positive if cell survival in the bioassay system in the absence and in the presence of rTNF antiserum was significantly different. The amount of TNF in each sample was calculated on the basis of dilution curves (1 unit of TNF being the amount of TNF giving 50% cell survival, 10 units being equivalent to 0.003 ng/ml rTNF). Of the 79 admission serum samples tested, 18 were positive for TNF (>TNF units/ml), antiserum against rTNF significantly reducing the cytotoxicity of the 18 samples. Thirteen of the TNF-positive patients had septic shock on admission (Table 1).

Table 10-6. *Details of patients*

Disease category on admission	Survivors	Patients who died	TNF-positive
I. Meningitis with no hypotension or ecchymoses	26	0	2
II. Septicemia with hypotension* and/or ecchymoses but no meningitis	12	8	11
III. Septicemia with hypotension* and/or ecchymoses and meningitis	15	2	2
IV. Septicemia with or without meningitis with no hypotension or ecchymoses	15	1	3

*Hypotension defined as systolic pressure <70 mmHg in subjects aged 12 years or 100 mmHg in subjects aged >12 years.

Hypotension developed in a further four TNF-positive patients within 2 hours of admission. TNF was detected in 10 of 11 patients who died, but in only 8 of 68 who survived. All patients with TNF cytotoxicity above 440 units/ml (equivalent to 0.1 ng/ml of rTNF) died. The correlation between the presence of TNF in serum and fatal outcome was highly significant (Table 2). The predictive value of leukopenia, thrombocytopenia, ecchymoses, and the presence of TNF were about equal with respect for a fatal outcome (sensitivity 0.95–0.98, specificity 0.55–0.63).

Table 10-7. Correlation between presence of TNF in serum and fatal outcome

Clinical features of severe meningococcal disease		Survivors	Patients who died	p value
TNF-positive		8	10	6 x 10 ⁻⁷
TNF-negative		60	1	
Leucocytes	<10 x 10 ⁹ /L	9	9	5 x 10 ⁻⁶
	>10 x 10 ⁹ /L	58	1	
Platelets	<100 x 10 ⁹ /L	4	7	5 x 10 ⁻⁵
	>100 x 10 ⁹ /L	58	3	
Ecchymoses				
	present	8	9	2 x 10 ⁻⁵
	absent	55	2	
Blood pressure*				
	low	20	10	3 x 10 ⁻⁴
	normal	48	1	

*Hypotension defined as for Table 1.

Citation count 991

Related references

1. Waage A, Espevik T, Lamvik J. Detection of tumour necrosis factor-like cytotoxicity in serum from patients with septicemia, but not from untreated cancer patients. *Scand J Immunol* 1986; **24**: 739–743.
2. Girardin E, Grau GE, Dayer J-M, Roux-Lombard P, The J5 Study Group and Lambert P-H. Tumour necrosis factor and interleukin-1 in the serum of children with severe infectious purpura. *N Engl J Med* 1988; **319**: 397–400.
3. Michie HR, Manogue KR, Spriggs DR *et al*. Detection of circulating tumour necrosis factor after endotoxin administration. *N Engl J Med* 1988; **318**: 1481–1486.
4. Suffredini AF, Fromm RE, Parker MM *et al*. The cardiovascular response of normal humans to the administration of endotoxin. *N Engl J Med* 1989; **321**: 280–287.
5. Fisher CJ, Agosti JM, Opal SM *et al*. Treatment of septic shock with the tumor necrosis factor receptor: Fc fusion protein. *N Engl J Med* 1996; **334**: 1697–1702.
6. Stuber F, Petersen M, Bokelmann F *et al*. A genomic polymorphism within the tumor necrosis factor locus influences plasma tumor necrosis factor- α concentrations and outcome of patients with severe sepsis. *Crit Care Med* 1996; **24**: 381–384.
7. Westendorp RGJ, Langermans JAM, Huizinga TWJ *et al*. Genetic influence on cytokine production and fatal meningococcal disease. *Lancet* 1997; **349**: 170–173.

8. Mira JP, Cariou A, Grall F *et al.* Association of TNF2, a TNF- α promotor polymorphism, with septic shock susceptibility and mortality. A multicenter study. *JAMA* 1999; **282**: 561–568.
9. Hermans PWM, Hibberd ML, Booy R *et al.* and the Meningococcal Research Group. 4G/5G promoter polymorphism in the plasminogen activator inhibitor-1 gene and outcome from meningococcal disease. *Lancet* 1999; **354**: 566–560.
10. Levin M, Quint PA, Goldstein B *et al.* and the rBPI21 Meningococcal Sepsis Study Group. Recombinant bactericidal/permeability-increasing protein (rBPI21) as an adjunctive treatment for children with severe meningococcal sepsis: a randomised trial. *Lancet* 2000; **356**: 961–967.

Key message

These observations showed that TNF was produced in human beings with severe meningococcal disease, and extended the authors' previous findings in patients with severe septicemia. Furthermore, there seemed to be a relationship between the serum TNF level, the severity of illness, and outcome.

Why it's important

This was the first study to document the relationship between systemic TNF serum concentrations and outcome in humans. It suggested the possibility that TNF was an essential mediator of septic shock, and encouraged a new approach in the treatment of the condition. The removal of TNF or the neutralization of its effect became an important feature of research in clinical sepsis. The link between the administration of endotoxin to humans and the production of TNF soon followed. The hypothesis that endotoxemia leads to an inflammatory cytokinemia (increased levels of IL-1, TNF, IL-6, and IL-8), and their interaction is critical in the pathogenesis of the tissue injury associated with sepsis, soon became established.

Strengths

1. A study of a single disease (severe meningococcal sepsis) caused by a specific micro-organism known to shed large amounts of endotoxin.
2. The use of a cytotoxic bioassay systems so that only biologically active TNF was detected.

Weaknesses

1. No information concerning the timing of administration of antimicrobial therapy in the patients studied.
2. Not readily reproducible as the bioassay used was developed locally, and hence was not available elsewhere.

Relevance

This study remains extremely important, because it emphasized the central role of TNF as a key mediator in septic shock. Furthermore, it reinforces the notion that a single microbiological disease should be studied in order to understand the exact relationship between host and invading microbe. Finally, therapies designed to inhibit, neutralize, or remove TNF are still under development, despite a number of disappointing randomized controlled clinical trials. Patient selection may be a key issue in this regard.

Title

Sepsis syndrome: a valid clinical entity: Methylprednisolone Severe Sepsis Study Group

Author

Bone RC, Fisher CJ, Clemmer TP, Slotman GJ, Metz CA, Balk RA and the Methylprednisolone Severe Sepsis Study Group

Reference

Crit Care Med 1989; **17**: 389–393

Abstract

The sepsis syndrome represents a systemic response to infection, and is defined as hypothermia (temperature < 96°F) or hyperthermia (> 101°F), tachycardia (> 90 beat/min), tachypnea (> 20 breath/min), clinical evidence of an infection site, and with at least one end-organ demonstrating inadequate perfusion or dysfunction expressed as poor or altered cerebral function, hypoxemia (PaO₂ < 75 torr), elevated plasma lactate, or oliguria (urine output < 30 ml/h or 0.5 ml/kg/h without corrective therapy). One hundred ninety-one patients with the sepsis syndrome were evaluated prospectively and comprised the placebo group of a multicenter trial of methylprednisolone in sepsis syndrome and septic shock. Forty-five percent of the patients were found to be bacteremic. Thirty-six percent of the patients were in septic shock (sepsis syndrome plus a systolic BP < 90 mmHg or a decrease from baseline in systolic BP > 40 mmHg) on study entry. An additional 23% of the patients developed shock after admission, with 70% doing so within 24 hours of study entry. Shock reversal occurred with a 73% frequency. Twenty-five percent of the patients developed the adult respiratory distress syndrome (ARDS). Mortality for the patients with sepsis syndrome who did not develop shock was 13%. Mortality for the groups of patients with shock on admission and shock post admission was 27.5% and 43.2%, respectively. Forty-seven percent of the bacteremic patients developed shock after study admission, compared to 29.6% of the nonbacteremic patients ($p < 0.05$).

Summary

This study describes the clinical features of the 'sepsis syndrome' occurring in 191 prospectively evaluated patients who comprised the placebo treatment group of a double-blind study of methylprednisolone in the sepsis syndrome and septic shock. Its purpose was to define a syndrome that could be distinguished on the basis of readily available, non-invasive clinical criteria at an earlier stage of deterioration than previously described. The sepsis syndrome was defined as the systemic response to sepsis (hypothermia (<96°F) or fever (>101°F); tachycardia (>90 beat/min); tachypnea (>20 breath/min)), together with clinical evidence of an infection site, and inadequate perfusion or dysfunction in one or more organ systems (altered cerebral function, hypoxemia, elevated plasma lactate, or oliguria). Overall, 142 patients (74%) survived. Shock, which was defined as a sustained (>1 hour) decrease in the systolic BP of at least 40 mmHg from baseline or a resultant systolic BP <90 mmHg after adequate volume replacement, was present in 69 of 191 patients on study entry (of whom 19 (28%) died). It developed in another 44 patients following study entry (19 (43%) deaths), whereas it was absent throughout the course of the illness in 77 patients (10 (13%) deaths). Temperature, platelet count, and bicarbonate were all significantly lower in the septic shock group compared with those patients who had the sepsis syndrome alone. In all, 45% (84/191) of the patients were bacteremic, and significantly more of these (58/84; 64%) developed septic shock compared with non-bacteremic patients (54/104; 52%).

Citation count 509

Related references

1. Bone RC, Fisher CJ, Clemmer TP, Slotman GJ, Metz CA, Balk RA and the Methylprednisolone Severe Sepsis Study Group. A controlled clinical trial of high-dose methylprednisolone in the treatment of severe sepsis and septic shock. *N Engl J Med* 1987; **317**: 653–658.
2. Bone RC, Fisher CJ, Clemmer TP, Slotman GJ, Metz CA, Balk RA and the Methylprednisolone Severe Sepsis Study Group. Early methylprednisolone treatment for septic syndrome and the adult respiratory distress syndrome. *Chest* 1987; **92**: 1032–1036.
3. American College of Chest Physicians/Society of Critical Care Medicine Consensus Conference Committee. ACCP/SCCM Consensus Conference: Definitions for sepsis and organ failure and guidelines for the use of innovative therapies in sepsis. *Crit Care Med* 1992; **20**: 863–874.
4. Bone RC. Immunological dissonance: a continuing evolution in our understanding of the systemic inflammatory response syndrome (SIRS) and the multiple organ dysfunction syndrome (MODS). *Ann Intern Med* 1996; **125**: 680–687.

Key message

The sepsis syndrome can be defined as the systemic manifestations of presumed sepsis using simple, easily obtained clinical criteria. Its definition does not require the presence of a positive blood culture nor hypotension that are integral to the diagnosis of bacteremia or septic shock, respectively. Progression from the sepsis syndrome to the associated sequelae of septic shock occurred at a rate high enough to warrant and justify aggressive therapeutic intervention at the point of onset of the sepsis syndrome itself.

Why it's important

This paper describes the criteria for the diagnosis of the sepsis syndrome. These subsequently formed the basis for the inclusion criteria of many sepsis trials of the 1990s. It led directly to the ACCP/SCCM Consensus Conference, and the subsequent definition of the systemic inflammatory response syndrome (SIRS). From a clinical perspective, its importance lies in the clinical description of the sepsis syndrome, formalizing the earlier recognition of a septic patient so that effective treatment, e.g. antimicrobial agents, can be instituted promptly.

Strengths

1. A part of a multi-center, randomized, double-blind, placebo-controlled clinical trial with strict inclusion and exclusion criteria.
2. Clear description of the incidence of septic shock in patients with the sepsis syndrome and their outcome.

Weaknesses

1. No details of the intensive therapy and antimicrobial treatment used to treat these patients.
2. Unclear at what time point the mortality rates were calculated, e.g. 28-day mortality, ICU mortality, hospital mortality.
3. Other than the comparison of bacteremic with non-bacteremic patients, no microbiological analysis provided.
4. Relatively naïve view of the septic process.

Relevance

This study is still extremely relevant, particularly as the diagnosis of sepsis remains essentially a clinical process.

Title

Efficacy and safety of recombinant human activated protein C for severe sepsis

Author

Bernard GR, Vincent J-L, Laterre P-F, LaRosa SP, Dhainaut J-F, Lopez-Rodriguez A, Steingrub JS, Garber GE, Helterbrand JD, Ely EW, Fisher CJ for the Recombinant Human Activated Protein C Worldwide Evaluation in Severe Sepsis (PROWESS) Study Group

Reference

N Engl J Med 2001; **344**: 699–709

Abstract

BACKGROUND: Drotrecogin alfa (activated), or recombinant human activated protein C, has antithrombotic, antiinflammatory, and profibrinolytic properties. In a previous study, drotrecogin alfa activated produced dose-dependent reductions in the levels of markers of coagulation and inflammation in patients with severe sepsis. In this phase 3 trial, we assessed whether treatment with drotrecogin alfa activated reduced the rate of death from any cause among patients with severe sepsis. **METHODS:** We conducted a randomized, double-blind, placebo-controlled, multicenter trial. Patients with systemic inflammation and organ failure due to acute infection were enrolled, and assigned to receive an intravenous infusion of either placebo or drotrecogin alfa activated (24 mg/kg/h) for a total duration of 96 hours. The prospectively defined primary end point was death from any cause, and was assessed 28 days after the start of the infusion. Patients were monitored for adverse events; changes in vital signs, laboratory variables, and the results of microbiologic cultures; and the development of neutralizing antibodies against activated protein C. **RESULTS:** A total of 1690 randomized patients were treated (840 in the placebo group, and 850 in the drotrecogin alfa activated group). The mortality rate was 30.8 percent in the placebo group and 24.7 percent in the drotrecogin alfa activated group. On the basis of the prospectively defined primary analysis, treatment with drotrecogin alfa activated was associated with a reduction in the relative risk of death of 19.4 percent (95 percent confidence interval, 6.6 to 30.5), and an absolute reduction in the risk of death of 6.1 percent ($p = 0.005$). The incidence of serious bleeding was higher in the drotrecogin alfa activated group than in the placebo group (3.5 percent vs. 2.0 percent, $p = 0.06$). **CONCLUSIONS:** Treatment with drotrecogin alfa activated significantly reduces mortality in patients with severe sepsis, and may be associated with an increased risk of bleeding.

Summary

This randomized, double-blind, placebo-controlled, multicenter (164 centres) phase 3 trial of 1728 patients with systemic inflammation and organ failure associated with sepsis assessed the effect of treatment with recombinant human activated protein C (drotrecogin alfa (activated); 24 µg/kg of body weight per hour for 96 hours) on all-cause 28-day mortality. Patients were eligible for randomization if they had a known or suspected infection, and three or more signs of systemic inflammation, with sepsis-induced dysfunction of at least one organ system that had lasted no longer than 24 hours. Patients had to begin treatment within 24 hours after they met the inclusion criteria. The trial was designed to enroll 2280 patients with two planned, independent, blinded interim analyses after the entry of 760 and 1520 patients. At the time of the second interim analysis of data from 1520 patients, enrollment was suspended because of a difference in mortality rates between the two groups that exceeded the *a priori* stopping rules. Finally, data were available from a total of 1690 patients who ultimately received either

the drug (n = 850) or placebo (n = 840). These were associated with a 28-day all-cause mortality of 24.7% and 30.8%, respectively (relative risk reduction of 19.4% (95% confidence interval 6.6–30.5%); absolute risk reduction 6.1% (p = 0.005); number needed to treat to save one life (1/ARR) = 16 patients; Figure 2). Protein C deficiency was present in 87.6% of the patients for whom levels were obtained. Plasma D-dimer levels were significantly lower in the drotrecogin alfa (activated) group than in patients in the placebo group on days 1–7 after the start of the infusion. The incidence of serious bleeding was higher in the drotrecogin alfa (activated) group than in the placebo group (3.5% vs 2.0%, p = 0.06).

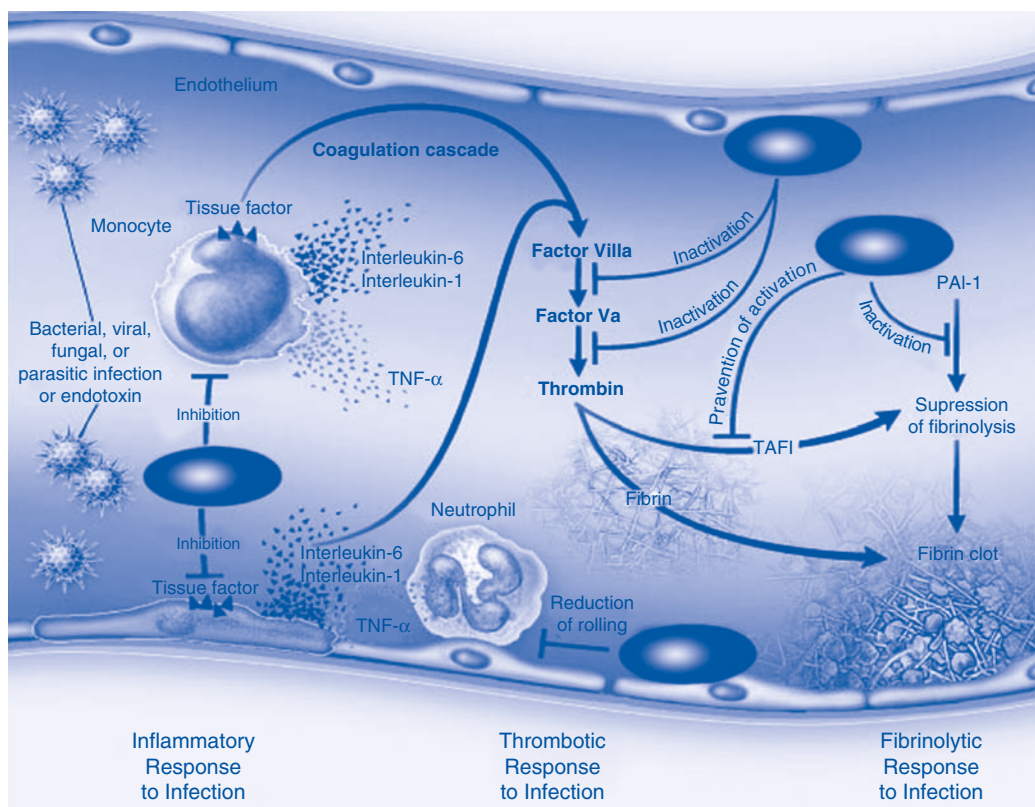

Fig. 10-1. Proposed actions of activated protein C in modulating the systemic inflammatory, procoagulant and fibrinolytic host responses to infection. The inflammatory and procoagulant host responses to infection are intricately linked. Infectious agents and inflammatory cytokines such as tumour necrosis factor- α (TNF- α) and interleukin-1 (IL-1) activate coagulation by stimulating the release of tissue factor from monocytes and the endothelium. The presentation of tissue factor leads to the formation of thrombin and a fibrin clot. Inflammatory cytokines and thrombin can both impair the endogenous fibrinolytic potential by stimulating the release of plasminogen-activator inhibitor 1 (PAI-1) from platelets and the endothelium. PAI-1 is a potent inhibitor of tissue plasminogen activator, the endogenous pathway for lysing a fibrin clot. In addition, the procoagulant thrombin is capable of stimulating multiple inflammatory pathways and further suppressing the endogenous fibrinolytic system by activating thrombin-activatable fibrinolysis inhibitor (TAFI). The conversion of protein C, by thrombin bound to thrombomodulin, to the serine protease activated protein C is impaired by the inflammatory response. Endothelial injury results in decreased thrombomodulin levels. The end result of the host response to infection may be the development of diffuse endovascular injury, microvascular thrombosis, organ ischaemia, multi-organ dysfunction and death. Activated protein C can intervene at multiple points during the systemic response to infection. It exerts an antithrombotic effect by inactivating factors Va and VIIIa, limiting the generation of thrombin. As a result of decreased thrombin levels, the inflammatory, procoagulant and antifibrinolytic responses induced by thrombin are reduced. *In vitro* data indicate that activated protein C exerts an anti-inflammatory effect by inhibiting the production of inflammatory cytokines (TNF- α , IL-1 and IL-6) by monocytes and limiting the rolling of monocytes and neutrophils on injured endothelium by binding selectins. Activated protein C indirectly increases the fibrinolytic response by inhibiting PAI-1. (Reproduced with permission from *N Engl J Med.*)

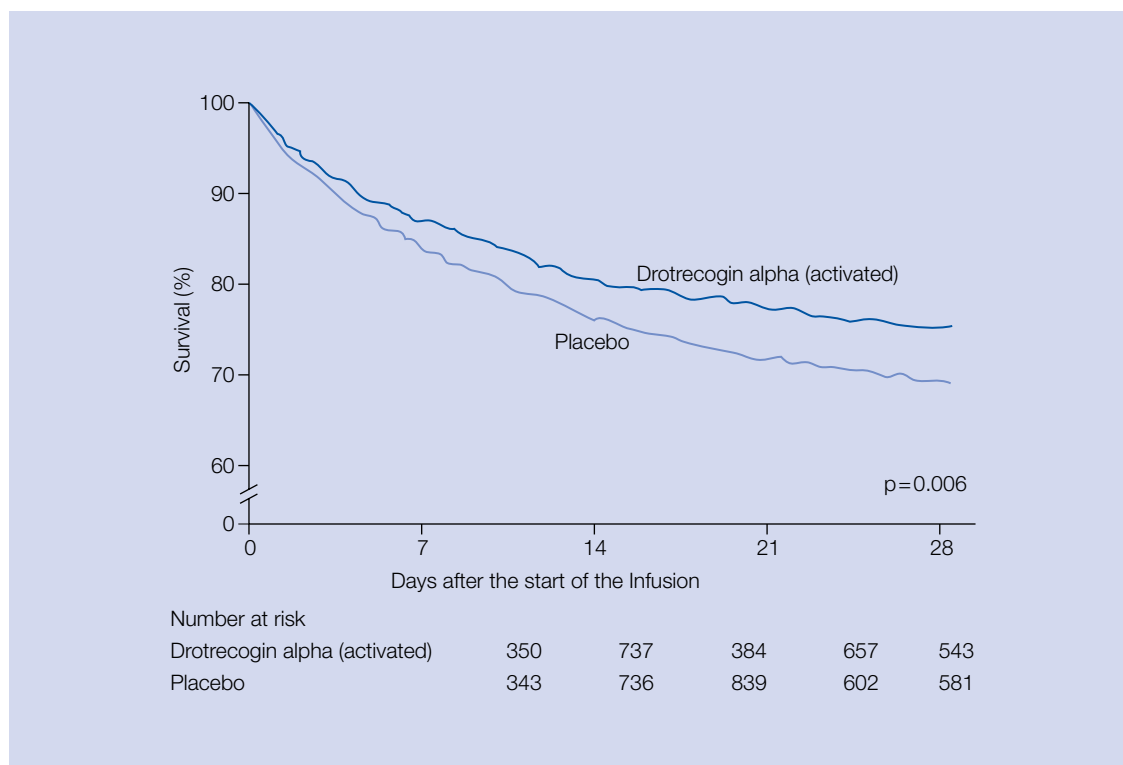

Fig. 10-2. Kaplan–Meier estimates of survival among 850 patients with severe sepsis in the drotrecogin alfa (activated) group and 840 patients with severe sepsis in the placebo group. Treatment with drotrecogin alfa (activated) was associated with a significantly higher rate of survival ($p = 0.006$ by the stratified log-rank test) (Reproduced with permission from *N Engl J Med.*)

Citation count 1898

Related references

1. Esmon CT, Taylor FB Jr, Snow TR. Inflammation and coagulation: linked processes regulated through a common pathway mediated by protein C. *Thromb Haemost* 1991; **66**: 160–165.
2. Levi M, ten Cate B. Disseminated intravascular coagulation. *N Engl J Med* 1999; **341**: 586–592.
3. Dhainaut J-F, Giroir B, Opal S. Introduction to the Second Margaux Conference on Critical Illness Sepsis: Interface Between Inflammation, Coagulation, and the Endothelium. *Crit Care Med* 2001; **29**: S1.
4. Marshall JC. Inflammation, coagulopathy, and the pathogenesis of multiple organ dysfunction syndrome. *Crit Care Med* 2001; **29**: S99–S106.
5. Fourier F, Chopin C, Huart J, Runge I, Caron C, Goudemand J. Double-blind, placebo controlled trial of antithrombin III concentrates in septic shock with disseminated intravascular coagulation. *Chest* 1993; **104**: 882–888.
6. Baudo F, Caimi TM, deCataldo F *et al.* Antithrombin III (ATIII) replacement therapy in patients with sepsis and/or postsurgical complications: a controlled double-blind, randomized, multicenter study. *Intensive Care Med* 1998; **24**: 336–342.

7. Opal SM. Therapeutic rationale for antithrombin III in sepsis. *Crit Care Med* 2000; **28**: S34–S37.

Key message

Treatment with drotrecogin alfa (activated) significantly reduced mortality in patients with severe sepsis. Greater decreases in D-dimer and IL-6 levels were also observed in the active treatment group. However, treatment with drotrecogin alfa (activated) was associated with an increased risk of bleeding consistent with the antithrombotic activity of the drug.

Why it's important

This study is a product of its time. It is a positive sepsis study suggesting that a 'magic bullet' (drotrecogin alfa activated) improves survival! The results are surprising, in so far as the theory of sepsis had not until now emphasized such an important pathogenic role for thrombin and microvascular thrombosis, and therapy with anti-thrombin/fibrinolysis factors. Moreover, the administration of antithrombin III, another naturally occurring anticoagulant with similar actions to drotrecogin alfa (activated), has not been shown to have an effect on outcome. Given the large number of negative sepsis studies published throughout the 1990s, the result of this study either makes the reader triumphant, in so far as finally we have a positive result, or it brings on an enormous bout of cynicism. At this stage, so close to the publication of the trial, it is impossible to know whether or not these results will stand the test of time, but one needs to bear in mind the enthusiasm and hype associated with the 1991 *New England Journal of Medicine* publication of the Ziegler HA-1A study, and take care.

Strengths

1. High quality, industry-supervised, FDA-approved phase III clinical trial in 164 centers in 11 countries.
2. Clear definition of sepsis (Appendix 1 in original publication).
3. Short window for the identification of sepsis, so that eligible patients were identified early.
4. Similar baseline characteristics of placebo and drotrecogin alfa (activated) groups (Table 1 in original publication).
5. Positive result.

Weaknesses

1. 1728 patients recruited over a 2-year period from 164 centers (5.15 patients per center per annum), suggesting a highly selected group of septic patients.
2. Extensive exclusion criteria (Appendix 2 in the original publication).
3. No information provided concerning patients not randomized into the study.
4. As usual, severity scores given in terms of APACHE II scores rather than APACHE II risk of death: APACHE II scores per se have not been validated as risk predictors.
5. Placebo 28-day mortality only 30.8% for a group of patients with an APACHE II score of 25 ± 7.8 . This suggests that the 28-day mortality rate did not represent the true mortality of the group, or that the standardized mortality rate of the group was significantly <1.0 .
6. Strictly limited end-point in the form of 28-day all-cause mortality. No information provided concerning hospital survival rates, 6-month survival, and quality of life of survivors at 6 months.
7. No cost-effectiveness analysis.

Relevance

These results are difficult to believe, but it is not easy to fault this study on methodological grounds other than on its strictly limited but FDA-approved end-point (28-day all-cause mortality). Most physicians, families, and patients dislike this end-point and prefer to have a body count around the time of hospital discharge. It seems to make more sense to examine how many patients actually leave hospital alive and get home to 'enjoy life in the community'. So, it makes even more sense to examine the function of survivors (so-called 'disability') and their subjective perception of their quality of life at 3 or 6 months after discharge. These end-points are always considered 'too difficult' for the pharmaceutical industry, despite the fact that a successful 'magic bullet' for sepsis is likely to cost anywhere between US \$5000 and \$10,000 per course.

In our own 12-bed general ICU in a Sydney teaching hospital, we have calculated that of the 750 admissions per annum, only 10% of the 100–120 septic patients would meet the entry criteria described in this study. Thus, at the cost of US \$5000–10,000 per patient treatment, we might treat only 10–12 patients with activated protein C each year for a total cost of US \$50,000–120,000 added to the ICU budget. Given that 16 patients need to be treated to save a life, and the risk of bleeding associated with activated protein C is quite considerable, the long-term outcome of surviving patients becomes all-important. In any event, the impact of activated protein C on outcome from sepsis in our ICU seems likely to be small. This situation continues to evolve.

Summing up

So where do we go from here? What does this selection of classic papers help us to understand about clinical sepsis and its management? The sepsis literature abounds with case series describing various patterns of presentation, components of the acute inflammatory response, and the hemodynamic, oxygen transport, and metabolic disturbances that subsequently lead on to multiple organ failure. Appropriate antimicrobial therapy, surgery when indicated, fluid resuscitation, mechanical ventilation, and vasopressor support (the so-called 'basics' of intensive care) have all been emphasized in management, but none have undergone the rigor of a randomized controlled clinical trial (RCCT). This form of assessment has been saved for steroids and other, more fashionable (and much more expensive) means of influencing the inflammatory, thrombotic, and fibrinolytic responses to sepsis. Surprisingly, the 'god-like' Evidence Based Critical Care Medicine group (32) have not turned their angry countenance on the 'basics' of intensive care, presumably assuming that there is enough 'lower evidence' to support their use. Only the lonely voice of a public health academic (33) has dared to question whether or not intensive care, or at least British intensive care, is truly effective, and thus should be tested by the standard RCCT rather than by observational studies (34,35).

Even in the absence of RCCTs, my own view is that there is considerable evidence to demonstrate that getting the antimicrobial agents right at the beginning is all-important (Paper no. 1, and references 23–27). I have labored this point because, in my experience, few residents and registrars in any specialty are either well schooled or interested in the use of antimicrobial agents (36,37). Aminoglycosides are a real problem because they are still widely used, and hence abused! At least in pneumonia and intra-abdominal sepsis, there appears to be better therapy available (38,39). Ototoxicity, usually not looked for in the ICU, is not uncommon in hematology patients even with once daily dosing (40). Nephrotoxicity in the elderly patient with intra-abdominal sepsis, who often has a degree of renal dysfunction to start with, is a recurring problem (41).

On the other hand, timely and appropriate surgical intervention is better understood – even by surgeons (42–44) – but unfortunately is not amenable to assessment by RCCT. Perhaps the most pertinent observation of the study by Eiseman *et al.* (Paper no. 4) was the role of 'surgical error' in the development of multiple organ failure, confirmation again of what Dr MacLean (Paper no. 2) described as 'inadequate surgery' in 16 cases of fatal sepsis amenable to surgical intervention. The debate now centers upon the usefulness or otherwise of a variety of imaging procedures that can often delay appropriate surgical intervention, or result in the inadequate percutaneous drainage of some collections (45). I do not subscribe to the view that a 'negative laparotomy' is a relatively harmless event in the course of a septic patient in the ICU, but 'sitting on a hot abdomen' ensures a rapid passage to multiple organ failure, and hence (by motor boat), across the Styx!

All published guidelines for the management of serious sepsis and septic shock emphasize the importance of aggressive fluid resuscitation (46, 47), but where are the RCCTs? The lack of consensus on the nature of the fluid used in resuscitation is well known (48, 49). Septic shock may be quite different from other forms of shock requiring volume therapy, but even that is far from clear. What fluid and how much remain unanswered questions, especially as the physiological goals of resuscitation and surrogate measures of outcome – blood pressure, cardiac output, blood lactate, gastric mucosal pH, DO_2 , VO_2 – have been devalued (50). A part of the problem relates to the inadequacies of using central venous and pulmonary arterial *pressures* to guide *volume* resuscitation (51), something that has been overcome recently with the simple bedside measurement of intrathoracic blood volume and lung water by trans-pulmonary thermodilution (52). More important, however, is the view that the nature of fluid may be relatively insignificant compared with the patient's hemodynamic response to whatever is administered – providing, of course, that adequate volumes are given. The literature seems to suggest that if

fluid therapy alone is associated with a 'good' response (an increase in blood pressure, cardiac output, DO_2 and VO_2 , with a fall in blood lactate and base deficit), then such patients do well (53, 54). On the other hand, if there is a lack of response to fluid therapy, and high-dose vasopressors are required, the outlook is grim (55, 56). There seems little new in this observation (see Paper no. 1), but it is worth bearing in mind when initiating high-dose vasopressor therapy in some patients (often the elderly) in the ICU who are obviously coming to the end of their lives!

There is little point in dwelling on the use of vasopressors and inotropes, in so far as there is no good evidence either way to support the use of any one in particular, or indeed any combination – and no obvious classic papers to quote! Once blood volume has been optimized, then both systemic pressure and flow must be maintained, with the end-point being the adequacy of tissue perfusion and end organ function. It seems logical to use a vasopressor with some inotropic effects, e.g. norepinephrine, to protect pressure while not inducing an excessive tachycardia. A relatively 'pure' inotrope, e.g. dobutamine, can be used to support myocardial function, and hence flow, especially in the face of a rising afterload (see Paper no. 7). Obviously, it is difficult to use these drugs without making measurements of cardiac output and preload, mean arterial pressure, systemic vascular resistance, blood lactate, and acid-base balance. There has been a lot of discussion about whether or not dopamine in high doses should be used before norepinephrine (57, 58), and whether or not epinephrine (adrenaline – 'God's own inotrope') has a detrimental effect on the splanchnic circulation (59, 60). My own practice is to start with fluids and norepinephrine and to add in dobutamine according to measurements of blood flow, blood pressure, and end organ function. Nowadays, I tend to reserve epinephrine for those who do not respond, but obviously these non-responders have an even worse prognosis. No mention has been made of non-specific nitric oxide synthase inhibition with mono-methyl-arginine (L-NMMA), since this approach in a large RCCT has been associated with an increased mortality rate (61).

Finally, given my own enthusiasm for gut protection, with early enteral nutrition using an immune-modulating formulation and the early introduction of bicarbonate-buffered high volume hemofiltration, it pains me to note the absence of any reference to either as a means of support for the septic patient. Again, this may be somewhat surprising, particularly in regard to the former, but it is difficult to find anything substantial in the literature to support their inclusion. The design of the early enteral and immune-modulating nutrition studies has been such that they have included mainly trauma and elective surgical patients, with the prevention of infection (rather than its treatment) being a primary end-point. Only the controversial Bower study (62), and the recent Spanish multi-center study of Galban *et al.* (63), purport to demonstrate beneficial effects of immune-modulating nutrition in septic groups of patients. Neither included a control group who received no enteral nutrition whatsoever, and as this is such a contentious area (64), it obviously needs more time to settle down. The same can be said for hemofiltration (65), but whether or not large trials will eventually be performed to sort out the respective roles of these two commonly used forms of organ support remains to be seen.

Those of us who work in intensive care would all like to write a 'classic' paper, or even a 'classic' chapter! Nevertheless, it is much more important in my view that in the management of sepsis, we do not get carried away by the science but keep our eye, on the ball! And the ball in this case is meticulous attention to the basics. The classic papers give us the basics, but there is still that trap of being 'more intensive than caring'. So let us all take care!

References

1. Ibsen B. The anaesthetist's viewpoint on the treatment of respiratory complications in poliomyelitis during the epidemic in Copenhagen, 1952. *Proc R Soc Med* 1954; **47**: 72–74.
2. Vincent JL, Bihari DJ, Suter PM *et al.* The prevalence of nosocomial infection in intensive care units in Europe – the results of the EPIC study. *JAMA* 1995; **274**: 639–644.

3. Pinner RW, Teutsch SM, Simonson L *et al.* Trends in infectious diseases mortality in the United States. *JAMA* 1996; **275**: 189–193.
4. Bone RC, Balk RA, Cerra FB *et al.* Definitions for sepsis and organ failure and guidelines for the use of innovative therapies in sepsis. *Chest* 1992; **101**: 1644–1655.
5. Vincent JL, Bihari D. Sepsis, severe sepsis or sepsis syndrome: need for clarification. *Intensive Care Med* 1992; **18**: 255–257.
6. Vincent JL. Dear SIRS, I'm sorry to say that I don't like you. *Crit Care Med* 1997; **25**: 372–374.
7. Dellinger RP, Bone RC. To SIRS with love. *Crit Care Med* 1998; **26**: 178–179.
8. Abraham E, Matthay MA, Dinarello CA *et al.* Consensus conference definitions for sepsis, septic shock, acute lung injury, and acute respiratory distress syndrome: time for a reevaluation. *Crit Care Med* 2000; **28**: 232–235.
9. Petros AJ, Marshall JC, Van Saene HKF. Should morbidity replace mortality as an endpoint for clinical trials in intensive care? *Lancet* 1995; **345**: 369–371.
10. Dellinger RP. Post hoc analyses in sepsis trials: a formula for disappointment? *Crit Care Med* 1996; **24**: 727–729.
11. Cassell GH, Mekalanos J. Development of antimicrobial agents in the era of new and reemerging infectious diseases and increasing antibiotic resistance. *JAMA* 2001; **285**: 601–605.
12. Borden CW, Hall WH. Fatal transfusion reactions from massive bacterial contamination of blood. *N Engl J Med* 1951; **245**: 760–765.
13. Waisbren BA. Gram-negative shock and endotoxin shock. *Am J Med* 1964; **36**: 819–824.
14. Wiles JB, Cerra FB, Siegel JH, Border JR. The systemic septic response: does the organism matter? *Crit Care Med* 1980; **8**: 55–60 (Paper no. 5, this chapter).
15. Bone RC, Fisher CJ, Clemmer TP, Slotman GJ, Metz CA, Balk RA and the Methylprednisolone Severe Sepsis Study Group. Sepsis syndrome: a valid clinical entity. *Crit Care Med* 1989; **17**: 389–393 (Paper no. 11, this chapter).
16. Morrison DC, Ulevitch RJ. The effects of bacterial endotoxins on host mediation systems. *Am J Pathol* 1978; **93**: 526–617.
17. Pastores SM, Katz DP, Kvetan V. Splanchnic ischemia and gut mucosal injury in sepsis and multiple organ dysfunction syndrome. *Am J Gastroenterol* 1996; **91**: 1697–1710.
18. Marston A. Gut rot. *Lancet* 1999; **355**: 1875–1877.
19. Bone RC, Grodzin CJ, Balk RA. Sepsis: a new hypothesis for pathogenesis of the disease process. *Chest* 1997; **112**: 235–243.
20. Baue AE. Multiple, progressive or sequential systems failure. A syndrome of the 1970s. *Arch Surg* 1975; **110**: 779–781.
21. Beale R, Bihari D. Multiple organ failure – the pilgrim's progresses. *Crit Care Med* 1992; **21**: S1–S3.
22. Wheeler AP, Bernard GR. Treating patients with severe sepsis. *N Engl J Med* 1999; **340**: 207–214.
23. Finland M, Jones WF, Barnes MW. Occurrence of serious bacterial infections since introduction of antibacterial agents. *JAMA* 1959; **84**: 2188–2197.
24. McCabe WR, Jackson GG. Gram-negative bacteremia. II. Clinical, laboratory and therapeutic observations. *Arch Intern Med* 1962; **110**: 856–864.

25. Moore RD, Lietman PS, Smith CR. Clinical response to aminoglycoside therapy: importance of the ratio of peak concentration to minimal inhibitory concentration. *J Infect Dis* 1987; **155**: 93–99.
26. Alvarez-Lerma F on behalf of the ICU Acquired Pneumonia Study Group. Modification of empiric antibiotic treatment in patients with pneumonia acquired in the intensive care unit. *Intensive Care Med* 1996; **22**: 387–394.
27. Ibrahim EH, Sherman G, Ward S *et al*. The influence of inadequate antimicrobial treatment of bloodstream infections on patient outcomes in the ICU setting. *Chest* 2000; **118**: 146–155.
28. Tobin MJ. Medical progress: advances in mechanical ventilation. *N Engl J Med* 2001; **344**: 1986–1996.
29. Callister MEJ, Evans TW. Haemodynamic and ventilatory support in severe sepsis. *J R Coll Physicians Lond* 2000; **34**: 522–528.
30. Zaloga GP. Early enteral nutritional support improves outcome: hypothesis or fact? *Crit Care Med* 1999; **27**: 259–261.
31. Honore PM, Jamez J, Wauthier M *et al*. Prospective evaluation of short-term, high-volume isovolemic hemofiltration on the hemodynamic course and outcome in patients with intractable circulatory failure resulting from septic shock. *Crit Care Med* 2000; **28**: 3581–3587.
32. Cook DJ, Sibbald WJ, Vincent JL, Cerra FB. Evidence based critical care medicine: what is it and what can it do for us? *Crit Care Med* 1996; **24**: 334–337.
33. McPherson K. Safer discharge from intensive care to hospital wards. *BMJ* 2001; **322**: 1261–1262.
34. Metcalfe A, Slogget A, McPherson K. Mortality among appropriately referred patients refused admission to intensive care units. *Lancet* 1997; **350**: 7–12.
35. Daly K, Beale R, Chang RWS. Reduction in mortality after inappropriate early discharge from the intensive care unit: logistic regression triage model. *BMJ* 2001; **322**: 1274–1276.
36. Bihari D. Choosing the right antibiotic. Right drug at right time in right dose saves lives. *BMJ* 1999; **319**: 919.
37. Kollef MH, Sherman G, Ward S, Fraser VJ. Inadequate antimicrobial treatment of infections: a risk factor for hospital mortality among critically ill patients. *Chest* 1999; **115**: 462–474.
38. Gleason PP, Meehan TP, Fine JM, Galusha DH, Fine MJ. Associations between initial antimicrobial therapy and medical outcomes for hospitalized elderly patients with pneumonia. *Arch Intern Med* 1999; **159**: 2562–2572.
39. Solomkin JS, Dellinger EP, Christou NV, Busuttill RW. Results of a multicentre trial comparing imipenem/cilastatin to tobramycin/clindamycin for intra-abdominal infections. *Ann Surg* 1990; **212**: 581–591.
40. El Bakri F, Pallett A, Smith AG, Duncombe AS. Ototoxicity induced by one-daily gentamicin. *Lancet* 1998; **352**: 70.
41. English WP, Williams MD. Should aminoglycoside antibiotics be abandoned? *Am J Surg* 2000; **180**: 512–515.
42. Miligan SL, Luft FC, McMurray SD, Kleit SA. Intra-abdominal infection in acute renal failure. *Arch Surg* 1978; **113**: 467–472.
43. Bohnen J, Boulanger M, Meakins JL, McLean AP. Prognosis in generalized peritonitis. Relation to cause and risk factors. *Arch Surg* 1983; **118**: 285–290.

44. Norton LW. Does drainage of intra-abdominal pus reverse multiple organ failure? *Am J Surg* 1985; **149**: 347–350.
45. O'Grady NP, Barie PS, Bartlett J *et al*. Practice parameters for evaluating new fever in critically ill adult patients. *Crit Care Med* 1998; **26**: 392–408.
46. Anonymous. Practice parameters for hemodynamic support of sepsis in adult patients with sepsis. Task Force of the American College of Critical Care Medicine, Society of Critical Care Medicine. *Crit Care Med* 1999; **27**: 639–660.
47. Management of Sepsis and Septic Shock. European Society of Intensive Care Medicine Summary of Recommendations. *Intensive Care Med* 2001; **27**: S128–S134.
48. Roberts I. Human albumin administration in critically ill patients: systematic review of randomised controlled trials. *BMJ* 1998; **317**: 235–240.
49. Choi PTL, Yip G, Quinonez LG, Cook DJ. Crystalloids vs. colloids in fluid resuscitation: a systematic review. *Crit Care Med* 1999; **27**: 200–210.
50. Heyland DK, Cook DJ, King D, Kernerman P, Brun-Buisson C. Maximising oxygen delivery in critically ill patients: a methodologic appraisal of the evidence. *Crit Care Med* 1996; **24**: 517–524.
51. Lichtwarck-Aschoff M, Zeravik J, Pfeiffer UJ. Intrathoracic blood volume accurately reflects circulatory volume status in critically ill patients with mechanical ventilation. *Intensive Care Med* 1992; **18**: 142–147.
52. Sakka SG, Ruhl CC, Pfeiffer UJ *et al*. Assessment of cardiac preload and extravascular lung water by single transpulmonary thermodilution. *Intensive Care Med* 2000; **26**: 180–187.
53. Tuchs Schmidt J, Fried J, Astiz M, Rackow E. Elevation of cardiac output and oxygen delivery improves outcome in septic shock. *Chest* 1992; **102**: 216–220.
54. Hayes MA, Timmins AC, Yau EH, Palazzo M, Watson D, Hinds CJ. Oxygen transport patterns in patients with sepsis syndrome or septic shock: influence of treatment and relationship to outcome. *Crit Care Med* 1997; **25**: 926–936.
55. Hayes MA, Timmins AC, Yau EH, Palazzo M, Hinds CJ, Watson D. Elevation of systemic oxygen delivery in the treatment of critically ill patients. *N Engl J Med* 1994; **330**: 1717–1722.
56. Abid O, Akca S, Haji-Michael P, Vincent JL. Strong vasopressor support may be futile in the intensive care unit patient with multiple organ failure. *Crit Care Med* 2000; **28**: 947–949.
57. Rudis MI, Basha MA, Zarowitzs BJ. Is it time to reposition vasopressors and inotropes in sepsis? *Crit Care Med* 1996; **24**: 525–537.
58. Martin C, Viviand X, Leone M *et al*. Effect of norepinephrine on the outcome of septic shock. *Crit Care Med* 2000; **28**: 2758–2765.
59. Meier-Hellmann A, Reinhart K, Bredle DL *et al*. Epinephrine impairs splanchnic perfusion in septic shock. *Crit Care Med* 1997; **25**: 399–404.
60. Taneja R, Marshall JC. Vasoactive agents and the gut: fueling the motor of multiple organ failure. *Crit Care Med* 2000; **28**: 3078–3123.
61. Grover R, Lopez A, Lorente J *et al*. Multi-center, randomized, placebo-controlled, double blind study of the nitric oxide synthase inhibitor 546C88 – effect on survival in patients with septic shock. *Crit Care Med* 1999; **27**: 33A.
62. Bower RH, Cerra FB, Bershadsky B *et al*. Early enteral administration of a formula (Impact®) supplemented with arginine, nucleotides and fish oil in intensive care patients: results of a multicenter, prospective, randomized, clinical trial. *Crit Care Med* 1995; **23**: 436–449.

63. Galban C, Montejo JC, Mesejo A *et al.* An immune-enhancing enteral diet reduces mortality rate and episodes of bacteremia in septic intensive care unit patients. *Crit Care Med* 2000; **28**: 643–648.
64. Heyland DK, Novak F. Immunonutrition in the critically ill: more harm than good? *JPEN* 2001; **25**: S51–S56.
65. Ronco C, Bellomo R, Homel P *et al.* Effects of different doses in continuous veno-venous haemofiltration on outcomes of acute renal failure: a prospective randomised trial. *Lancet* 2000; **355**: 26–30.

Nutrition and metabolism

Jan Wernerman

Introduction

With a perspective on the literature of nutrition and with special emphasis upon intensive care patients, the papers that stand out as citation classics cover very different fields. As the selection was done some time ago, some recent entries in to the field may qualify, but on the other hand, it takes a few years to build a citation classic. The papers by Clowes, Streat and Gamrin *et al.* deal with pathophysiology with some emphasis upon body composition and the depletion of muscle. Clowes *et al.* were the first to show the elevated efflux of amino acids from muscle. Streat *et al.* were the first to show that body proteins are depleted and that hypercaloric treatment will only result in fat gain. Gamrin *et al.* were the first to show in biochemical terms the quantitative loss of muscle proteins. These papers represent a body of literature which includes a series of influential studies that explored the alterations in metabolism that occurred with various states, and sought to identify what happened in terms of the metabolism and catabolism of various substrates. They also sought to identify which synthetic pathways were maintained or enhanced, and which were inhibited, which substrates were easily utilized for fuel, and which were not. There was interest in how the endocrine profile mobilized substrates, and also how it interfered with exogenous support.

A second group of papers focus on the handling of macronutrients in ICU patients. Larsson *et al.* demonstrated that there is an upper limit beyond which provision of proteins or amino acids does not benefit nitrogen balance. Sandström *et al.* demonstrated that it is not possible, without adverse effects, to have a standardized nutritional program for post-surgery patients. It is necessary to individualize the treatment, particularly in those patients who require treatment in the ICU. They also demonstrated that parenteral nutrition on a routine basis postoperatively is not indicated. Through these studies, it became clear that the pathophysiology of nutritional support was complex, and that simplistic interventions could create unforeseen problems. This phenomenon was rediscovered years later, when attempts to crudely modify the endocrine profile with the administration of growth hormone did not have the desired effects.

The remaining papers are outcome studies of ICU patients – a field in which there are considerable controversies. The papers by Moore, Bower and Atkinson *et al.* are prospective clinical trials of immunonutrition. The Moore study was in trauma patients and focused on septic morbidity, while the studies by Bower *et al.* and Atkinson *et al.* represent more mixed ICU material from North America and Europe, respectively. All these studies on enteral nutrition in ICU patients represent an important step forward. They are the first generation of this type of study, and are therefore to some extent representatives of the inherent problems with this type of study. The success rate in administration of enteral nutrition is not always sufficient, and therefore the results, according to the prospective primary outcome variable, are not conclusive in any of the studies. Also, the inequality in mortality between the treatment group and the control groups in the studies by Bower and Atkinson *et al.* further adds to the difficulty in reaching any definite conclusions. Still, these papers represent milestones demonstrating that it is possible to carry out large multi-center (or single-center) studies on nutrition in ICU patients.

Finally, the papers by Griffiths *et al.* and Houdijk *et al.* concern the use of glutamine-enriched nutrition by parenteral and enteral route, respectively, in ICU patients. The study

by Griffiths *et al.* is not a big study, and it comes from a single center, but otherwise it represents a quality perspective randomized controlled nutritional trial in ICU patients. It is also a milestone, being the first nutrition study in ICU patients with a long-term perspective on outcome. Prospective 6-month mortality was the primary outcome variable of that particular study. The paper by Houdijk *et al.* reports on glutamine provision by the enteral route to trauma patients, and it is in many respects a parallel to the Moore study.

Just as exciting as the developments in the practice of nutrition has been the evolution of the scientific method. Unraveling the physiology of the stress state has posed huge questions, the answers to many of which are still being sought. Identifying methods of administering nutrition and determining what is most appropriate in illness is also an area of active investigation. Possibly the most challenging part of the picture is determining how nutrition impacts on outcome in the critically ill population, which by definition is a massively heterogeneous population. Many of the papers selected were impressive not just because of the questions asked or the results found, but also because they illustrate the development of scientific method in this field.

Any selection of citation classics in ICU nutrition will be very subjective, and therefore open to criticism. Nevertheless, these papers are not only frequently cited, but also have had an important role in building up understanding and quality in this particular field of research.

Title

Amino acid and energy metabolism in septic and traumatized patients

Author

Clowes GHA, Randell HT, Chu CJ

Reference

J Parent Enter Nutr 1980; **4**: 195–205

Summary

In this study, two groups of patients ($n = 14 + 12$), those with major infections and those in the post-shock phase of severe but uninfected trauma, were compared, with normal volunteers fasted overnight ($n = 5$). Each of the patients in both the septic and the post-traumatic group were in the phase of elevated cardiac output, which in the past has been shown to be characteristic of patients who 'do well' and recover.

The authors concluded that the metabolic derangements in the high output septic and post-traumatic states are similar. Accelerated proteolysis in muscle tissues is accompanied by hyperglycemia, and a greater peripheral uptake of glucose. However, a proportionately greater portion of pyruvate derived from glucose is employed to produce lactate and alanine in muscle. Associated with the increase of net protein degradation in muscle is the greater availability of all amino acids, for healing and for synthesis of other proteins by central tissues. The large quantities of lactate, alanine, and glutamine (all glucogenic precursors), released into the blood by muscle tissue must be cleared by hepatic and other routes of glucogenesis in gut and kidney.

Thus, it may be concluded that the alterations of muscle metabolism which occur in conjunction with accelerated breakdown of its proteins are, in great measure, responsible for the hyperglycemia, and the high rate of glucose turnover characteristic of sepsis and trauma. All these phenomena appear to be secondary to accelerated muscle proteolysis rather than the other way around.

Citation count 207

Related references

1. Long CL, Birkhahn RH, Geiger JW *et al.* Urinary excretion of 3-methylhistidine: an assessment of muscle protein catabolism in adult normal subjects and during malnutrition, sepsis, and skeletal trauma. *Metabolism* 1981; **30**: 765–776.
2. Cerra FB. Hypermetabolism, organ failure, and metabolic support. *Surgery* 1987; **101**: 1–14.

Key message

After trauma and in sepsis, the efflux of free amino acids from peripheral tissues is doubled or tripled without altering the composition of the amino acid efflux.

Why it's important

This is the pioneer work elucidating the efflux of amino acids from the leg in patients undergoing major surgery and in patients with sepsis. It provided the background as to why muscle depletion occurs in these patients, and also the origin of the negative nitrogen balance seen in these patients, which relates to the breakdown of muscle proteins. This had been hypothesized by Sir David Gutbertson 50 years earlier, but was actually shown in patients for the first time in this study. The key observation was that the pattern of amino acid efflux did not change from the basal state to this catabolic state, and that this efflux is quite different from the amino acid composition of free amino acid in muscle tissue, as well as in muscle proteins.

Strengths

The originality of the work; it demonstrated the use of methodologies that can be employed in unstable patients.

Weaknesses

The clinical details of the patients are not in accord with today's standards. It was clearly not possible to analyze comprehensively the full array of individual amino acids at that time.

Relevance

A 'real' citation classic. One of many important studies from George Clowes' group, highlighting one of the major pathophysiological mechanisms in catabolic ICU patients, giving the necessary background for the nutritional studies.

Title

Aggressive nutritional support does not prevent protein loss despite fat gain in septic intensive care patients**Author**

Streat SJ, Beddoe AH, Hill GL

Reference

J Trauma 1987; **27**: 262–266**Abstract**

It is current clinical practice to give intravenous nutrition (IVN) to critically ill, postoperative, septic intensive care patients to prevent loss of body protein, although it has not hitherto been possible to confirm this by direct measurement of body composition. Using a neutron activation analysis facility adapted to provide an intensive care environment, and tritiated water dilution, we directly measured total body water, protein, and fat before and after 10 days of IVN (mean daily non-protein energy and amino acid intakes 2,750 kcal and 127 gm) in eight adult intensive care patients. All patients had recovered from the septic shock syndrome but were still ventilator dependent at the start of IVN. Six patients survived to leave hospital. As a group, the patients lost 12.5% of body protein (mean loss 1.5 +/- SE 0.3 kg; p = 0.001), despite a gain in fat (mean 2.2 +/- 0.8 kg; p = 0.026). There were, in addition, large losses of body water in most patients (mean, 6.8 +/- 2.6 kg; p = 0.036). We conclude that substantial losses of body protein occur in critically ill septic patients despite aggressive nutritional support, and that further research is urgently required on the fate of infused substrates, and the efficacy of alternative nutritional therapies.

Citation count 243

Related references

1. Ishibashi N. Optimal protein requirements during the first 2 weeks after the onset of critical illness. *Crit Care Med* 1998; **26**: 1529–1535.
2. Finn PJ, Plank LD, Clark MA, Connolly AB, Hill GL. Progressive cellular dehydration and proteolysis in critically ill patients. *Lancet* 1996; **347**: 654–656.
3. Miller JD, Blackburn GL, Bistran BR *et al*. Effect of deep surgical sepsis on protein-sparing therapies and nitrogen balance. *Am J Clin Nutr* 1977; **30**: 1528–1532.
4. Cerra FB, Siegel JH, Coleman B *et al*. Septic autocannibalism. A failure of exogenous nutritional support. *Ann Surg* 1980; **192**: 570–580.
5. Wolfe RR. Herman Award Lecture, 1996: relation of metabolic studies to clinical nutrition – the example of burn injury. *Am J Clin Nutr* 1996; **64**: 800–808.

Key message

Septic ICU patients become depleted in lean body mass, regardless of nutritional support.

Why it's important

This was the first in a number of studies from this group looking at body composition in intensive care patients, and also in patients undergoing major surgery. This paper, which is an uncontrolled small pilot study, demonstrated that the loss of protein was probably minimized in response to aggressive nutrition however; at the expense of having a considerable gain of body fat. When published, this was one of the first indicators that overfeeding probably could be a considerable clinical problem.

Strengths

Good methodology. It provides important information concerning the pathophysiology of the altered metabolism associated with critical illness.

Weaknesses

It is a pilot study, which in itself does not allow the possibility of distinguishing between different nutritional factors. The patients in the study were definitely overfed by today's standards.

Relevance

This citation classic has had an enormous impact on adjusting nutritional support to levels that are not hazardous for patients. The demonstration that a large gain in fat tissue had occurred has had a definite impact on nutrition routines.

Title

Nitrogen requirements in severely injured patients

Author

Larsson J, Lenmarken C, Mårtensson J, Sandstedt S, Vinnars E

Reference

Br J Surg 1990; **77**: 413–416

Abstract

The study was designed to evaluate nitrogen needs in severely injured patients during the first week after trauma. Thirty-nine patients aged from 18 to 65 years with a burn, or fractures of more than two long bones, were studied. Energy requirements were given parenterally as fat and glucose in isocaloric amounts. The patients were randomized into five groups receiving different amounts of nitrogen, from zero to 0.3 g/kg/d. Daily and cumulative nitrogen balance, urinary 3-methylhistidine excretion, and nitrogen retention were calculated on days 2–8 after trauma. With no nitrogen, the mean (s.e.m.) daily nitrogen balance after the trauma was –13.8 (0.5) gN. The balance improved markedly in groups with a nitrogen intake of up to 0.2 g/kg/d ($p < 0.001$), compared with the no-nitrogen group. The 3-methylhistidine excretion increased because of the trauma in all groups, with no statistically significant difference between the groups. Nitrogen retention decreased with increase in nitrogen supply, and with time after injury. It is suggested that a nitrogen supply of 0.20, g/kg/d is optimal for severely injured patients during the first week after trauma.

Citation count 36

Related references

1. Belcher HJ, Judkins KC. Determinants of urinary nitrogen excretion in burned patients. *Burns Incl Therm Inj* 1988; **14**: 303–307.

Key message

Parenteral nutrition containing >0.10 – 0.15 g nitrogen/kg/day does not further improve nitrogen balance. Although there may be other potential benefits from extra nitrogen, overfeeding with nitrogen also represents a metabolic burden for the patient. This study clearly demonstrates that when given together with an adequate amount of energy, extra nitrogen is not beneficial in terms of nitrogen balance.

Why it's important

This was the first prospective study showing the limitations and possible hazards of nitrogen overfeeding. It was presented at a time when reports were increasingly showing that overfeeding was perhaps as large a problem as underfeeding in intensive care patients. Both an excess of calories and excess nitrogen were very common. This study made consensus recommendations of the need for nitrogen to be adjusted downwards, something that has helped to limit the adverse effects related to intravenous nutrition.

Strengths

A longitudinal, prospective, well-designed study.

Weaknesses

The patient population, which comprised trauma and burned patients, perhaps did not require ICU stay for the entire period.

Relevance

A citation classic in its capacity of indicating that more modest nutritional support is more in line with the need of the patient. Important as it also demonstrated that meticulous nitrogen balance studies may provide valuable information about ICU patients.

Title***The effect of postoperative intravenous feeding (TPN) on outcome following major surgery evaluated in a randomized study***

Author

Sandström R, Drott C, Hyltaander A, Arvidsson B, Scherstén T, Wickström I, Körner U, Gülich-Iresjö B-M, Lundholm K

Reference

Ann Surg 1993; **217**: 185–195

Abstract

Three hundred patients undergoing major general surgical procedures were randomized by means of a computer-assisted algorithm to receive either total parenteral nutrition (TPN) from the first postoperative day, or only prolonged glucose administration (250–300 g/day), up to 15 days after operation. All patients receiving TPN were treated individually, based on daily measurements of energy and nitrogen balances. The treatment goal was to keep the patients in positive energy balance (+20%), and close to nitrogen balance. The effects of the two 'nutrition regimens' on outcomes such as mortality rate, complications, the need of additional medical support, and patient-related functional disabilities were investigated. No selection of patients was made; that is, malnourished patients were also randomized. There were no differences among TPN versus glucose treatment when results were analyzed according to intent to treat. Approximately 60% of all patients were able to start eating within 8 to 9 days after operation. No differences were observed between such patients, regardless of being treated with TPN or glucose only. Patients on glucose treatment during 14 days had a significantly higher mortality rate ($p < 0.05$) than patients on either continuous and uncomplicated TPN treatment, or short-term glucose treatment. Similar results for mortality rates also were seen with regard to severe complications (cardiopulmonary problems, sepsis, and wound-healing insufficiencies), functional disturbances, the need of additional medical support, and abnormalities in nutritional state. Twenty percent of the patients randomized to TPN treatment showed a statistical trend ($p < 0.10$) toward a higher mortality rate (36%), compared with patients randomized to prolonged glucose treatment (21% mortality rate). These patients could not be identified by evaluation of preoperative factors. Thus, the overall evaluation of the results makes it likely that a fraction of high-risk patients (approximately 20%) were not doing well on immediate postoperative intravenous feeding, and it is possible that TPN to such patients accentuated their morbidity rate. Although patients (20%) on prolonged semi-starvation (14 days glucose treatment) had increased mortality rate and severe complications, it was possible that undernutrition induced a slightly different complication scenario than induced by TPN in the high-risk patients. The results demonstrate that in most surgical patients (60%), postoperative semi-starvation is not a limiting factor for outcome. In the remaining 40%, inadequate nutrition was associated with both increased morbidity and mortality rates. In this sense, inadequate nutrition represents both too much and too little, whereas overfeeding seemed to be a larger problem than underfeeding. Based on results in the current study, we propose that TPN represents a life-saving modality in approximately 20% of unselected patients undergoing major surgical procedures. Unfortunately, so far it is not possible to identify these patients by preoperative criteria.

Citation count

103

Related references

1. Campos AC, Meguid MM. A critical appraisal of the usefulness of perioperative nutritional support. *Am J Clin Nutr* 1992; **55**: 117–130.
2. Fan ST, Lo CM, Lai EC *et al*. Perioperative nutritional support in patients undergoing hepatectomy for hepatocellular carcinoma. *N Engl J Med* 1994; **331**: 1547–1552.
3. Higgins CS, Keighley MR, Allan RN. Impact of preoperative weight loss and body composition changes on postoperative outcome in surgery for inflammatory bowel disease. *Gut* 1984; **25**: 732–736.

Key message

Postoperative nutrition is important and potentially lifesaving for a considerable subgroup of patients undergoing major surgical procedures. However, it is not possible to define these patients preoperatively.

Why it's important

In nutritional literature, a large number of studies have attempted to evaluate the effect of postoperative nutritional treatment. Most of these studies have considerable methodological problems. This study by Sandström *et al*. represents an effort to overcome these methodological problems. Unfortunately, the two groups represent a low calorie feeding regimen versus TPN. Many centers would today include a large proportion of these patients in programs of early enteral feeding postoperatively. Nevertheless, the study indicates that a certain proportion of patients undergoing major surgery end up as intensive care patients with accompanying nutritional problems. Although there are risk assessments for patients undergoing major surgery, there are no good indices to determine which patients will have postoperative morbidity that requires ICU treatment, and where nutritional support may be of critical importance.

Strengths

A large, randomized prospective controlled study in a well-defined patient population. It was meticulously performed, and provides a wealth of valuable information. Although not conclusive as regards the prospective primary end-point, it clearly indicates that postoperative nutrition following major surgery is an important clinical problem.

Weaknesses

The protocol does not contain any defined program for early enteral feeding postoperatively.

Relevance

This study put a definite emphasis on how to identify high-risk patients when designing protocols for postoperative feeding. Furthermore, it indicated that any routinely used program for postoperative parenteral feeding will overfeed a certain fraction of patients, if not in terms of calories and nitrogen, then in terms of given volume.

Title

Clinical benefits of an immune-enhancing diet for early postinjury enteral feeding

Author

Moore FA, Moore EE, Kudsk KA, Brown RO, Bower RH, Koruda MJ, Baker CC, Barbul A

Reference

J Trauma 1994; **37**: 607–615

Abstract

In this multicenter prospective controlled trial, 98 evaluable patients sustaining major torso trauma were randomized to receive early enteral nutrition with a new 'immune-enhancing' diet (study: n = 51), or a standard stress enteral formula (control: n = 47). At baseline, both groups had comparable demographics and Injury Severity Scores. After 7 days of feeding, the groups had equivalent increases in serum total protein, albumin, and transferrin concentrations. Patients receiving the 'immune-enhancing' diet, however, experienced significantly greater increases in total lymphocyte (p = 0.014), T lymphocyte (p = 0.04), and T-helper (p = 0.004) cell numbers. Additionally, these patients had significantly fewer intra-abdominal abscesses (study, 0% vs. control, 11%; p = 0.023), and significantly less multiple organ failure (study, 0% vs. control, 11%; p = 0.023). In conclusion, this multicenter trial suggests this 'immune-enhancing' enteral diet offers clinical benefits in stressed surgical patients.

Citation count 165

Related references

1. Casey J, Flinn WR, Yao JS *et al.* Correlation of immune and nutritional status with wound complications in patients undergoing vascular operations. *Surgery* 1983; **93**: 822–827.
2. Cerra FB, Lehmann S, Konstantinides N *et al.* Improvement in immune function in ICU patients by enteral nutrition supplemented with arginine, RNA, and menhaden oil is independent of nitrogen balance. *Nutrition* 1991; **7**: 193–199.
3. Daly JM, Lieberman MD, Goldfine J *et al.* Enteral nutrition with supplemental arginine, RNA, and omega-3 fatty acids in patients after operation: immunologic, metabolic, and clinical outcome. *Surgery* 1992; **112**: 56–67.

Key message

An immune-enhanced enteral diet decreases morbidity in trauma patients requiring ICU treatment.

Why it's important

This was the first study to indicate that nutritional treatment may have an impact upon outcome. Although this is a multi-center study, it is comparatively small and has low statistical power, but it suggested that these types of studies would be necessary in the future.

Strengths

A prospective randomized study with a well-designed protocol. Measures of morbidity are well defined.

Weaknesses

Poorly controlled in terms of whether the prescribed amount of nutrition was actually delivered. There was a high frequency of intra-abdominal abscesses in the control group, and the differences were confined to these patients. The patient population studied is a small subgroup of ICU patients with a very low mortality.

Relevance

This study is a citation classic, as it demonstrated an effect upon infectious morbidity related to nutrition. The immune-enhanced formula used contains all additives that have been suggested to be beneficial; therefore, it is not possible to relate the result to any particular ingredient.

Title***Early enteral administration of a formula (Impact) supplemented with arginine, nucleotides, fish oil in intensive care unit patients: results of a multi-center prospective, randomized clinical trial***

Author

Bower R, Cerra F, Bershadsky B, Licari J, Hoyt D, Jensen G, van Buren C, Rothkopf M, Daly J, Adelsberg B

Reference

Crit Care Med 1995; **23**: 436–449

Abstract

OBJECTIVE: To determine if early enteral feeding, in an intensive care unit (ICU) patient population, using a formula supplemented with arginine, dietary nucleotides, and fish oil (Impact), results in a shorter hospital stay and a reduced frequency of infectious complications, when compared with feeding a common use enteral formula (Osmolite.HN). **DESIGN:** A prospective, randomized, double-blind, multicenter trial. **SETTING:** ICUs in eight different hospitals. **PATIENTS:** Of 326 patients enrolled in the study, 296 patients were eligible for analysis. They were admitted to the ICU after an event such as trauma, surgery, or sepsis, and met a risk assessment screen (Acute Physiology and Chronic Health Evaluation II [APACHE II] score of $>$ or $=$ 10, or a Therapeutic Intervention Scoring System score of $>$ or $=$ 20) and study eligibility requirements. Patients were stratified by age, ($<$ 60 or \geq 60 years of age), and disease (septic or systemic inflammatory response syndrome). **INTERVENTIONS:** Patients were enrolled and full-strength tube feedings were initiated within 48 hours of the study entry event. Enteral feedings were advanced to a target volume of 60 mL/hr by 96 hours of the event. One hundred sixty-eight patients were randomized to receive the experimental formula, and 158 patients were randomized to receive the common use control formula. **MEASUREMENTS AND MAIN RESULTS:** Both groups tolerated early enteral feeding well, and the frequency of tube feeding-related complications was low. There were no significant differences in nitrogen balance between groups on study days 4 and 7. Patients receiving the experimental formula had a significant ($p = 0.0001$) increase in plasma arginine and ornithine concentrations by study day 7. Plasma fatty acid profiles demonstrated higher concentrations of linoleic acid ($p < 0.01$) in the patients receiving the common use formula, and higher concentrations of eicosapentaenoic and docosahexaenoic acid ($p < 0.01$) in the patients receiving the experimental formula. The mortality rate was not different between the groups, and was significantly ($p < 0.001$) lower than predicted by the admission severity scores in both feeding groups. In patients who received at least 821 mL/day of the experimental formula, the hospital median length of stay was reduced by 8 days ($p < 0.05$). In patients stratified as septic, the median length of hospital stay was reduced by 10 days ($p < 0.05$), along with a major reduction in the frequency of acquired infections ($p < 0.01$) in the patients who received the experimental formula. In the septic subgroup fed at least 821 mL/day, the median length of stay was reduced by 11.5 days, along with a major reduction in acquired infections (both $p < 0.05$) in the patients who received the experimental formula. **CONCLUSIONS:** Early enteral feeding of the experimental formula was safe and well tolerated in ICU patients. In patients who received the experimental formula, particularly if they were septic on admission to the study, a substantial reduction in hospital length of stay was observed, along with a significant reduction in the frequency of acquired infections.

Citation count 292

Related references

1. Wischmeyer PE, Lynch J, Liedel J *et al.* Glutamine administration reduces Gram-negative bacteremia in severely burned patients: a prospective, randomized, double-blind trial versus isonitrogenous control. *Crit Care Med* 2001; **29**: 2075–2080.

Key message

An immune-enhanced enteral diet may reduce the frequency of acquired infections in ICU patients, in particular those who were septic on admission to the study.

Why it's important

The study is a citation classic because it was the first large multi-center study with enteral nutrition protocols. It demonstrated that it is possible to undertake this type of study. At the same time, it highlights a number of difficulties such as randomization, control of nutritional intake, how to handle morbidity outcome parameters in patient populations with a significant mortality, and also the importance of formulating a hypothesis to be used when making statistical power calculations before the study.

Strengths

A large multi-center study. A lot of information is clearly and openly stated in the manuscript.

Weaknesses

The groups are not sufficiently randomized for mortality. The control of nutritional intake is non-existent. The conclusions are insufficiently substantiated in the results.

Relevance

At the time of publication, this study was unique. It pointed out the necessity of performing outcome studies related to nutritional treatment. The manuscript has caused considerable debate, which eventually has led to the formulation of proper standards for multi-center nutritional studies.

Title

Six-month outcome of critically ill patients given glutamine-supplemented parenteral nutrition

Author

Griffiths RD, Jones C, Palmer TE

Reference

Nutrition 1997; **13**: 295–302

Abstract

An abundant amino acid in the human body, glutamine (Gln) has many important metabolic roles that may protect or promote tissue integrity and enhance the immune system. Low plasma and tissue levels of Gln in the critically ill suggest that demand may exceed endogenous supply. A relative deficiency of Gln in such patients could compromise recovery, and result in prolonged illness and an increase in late mortality. This study examines this hypothesis. Using a prospective, block-randomized, double-blind treatment study design, we tested whether a Gln-containing parenteral nutrition (PN) compared with an isonitrogenous, isoenergetic control feed would influence outcome, with the endpoints of morbidity, mortality, and cost at 6 months postintervention. In one general intensive care unit (ICU), to ensure consistency of management policies, 84 critically ill adult patients, with Acute Physiological and Chronic Health Evaluation II score > 10, requiring nutritional support, received PN only if enteral nutrition was contraindicated or unsuccessful. Survival at 6 months was significantly improved in those receiving Gln PN (24/42 versus 14/42; $p = 0.049$). Significantly more deaths occurred in patients requiring control PN for > 10 day ($p = 0.03$). The excess control deaths occurred later, and those patients had had a significantly longer postintervention stay ($p = 0.012$) and use of ICU. In the Gln recipients, the total ICU and hospital cost per survivor was reduced by 50%. In critically ill ICU patients unable to receive enteral nutrition, a Gln-containing PN solution improves survival at 6 months and reduces the hospital costs per survivor.

Citation count 244

Related references

None

Key message

Six-month mortality was reduced in a prospective, controlled, randomized, single-center clinical trial comparing glutamine-supplemented parenteral nutrition to conventional parenteral nutrition. The difference between the treatment group and the controls was related both to the time in the unit and the convalescence time.

Why it's important

This is the first study in the ICU literature demonstrating an effect upon mortality related to nutritional treatment. The design was novel, in the sense that it introduced 6-month mortality as a standard mortality measure, which in itself is a major contribution. 30-day mortality or in-unit mortality may completely miss important effects of nutritional treatment upon the depletions in ICU patients.

Strengths

1. Prospective, straightforward design.
2. 6-month mortality as outcome.
3. Controlled, in the sense that all patients got the prescribed nutrition.

Weaknesses

Comparatively small study with low statistical power.

Relevance

Although heavily debated, the Griffiths study demonstrates that nutritional treatment may have an impact upon outcome in terms of mortality. The criticism has focused upon whether the deaths were related to glutamine depletion or not. This is an unfair criticism, as the hypothesis was that extra glutamine provision would attenuate the depletion, and thereby a lower mortality related to any cause of death. The only valid criticism is that of low statistical power, which is of course a major problem in a single-center study aimed at a group of patients – i.e. those requiring parenteral nutrition – which has a higher mortality than most other groups of ICU patients.

Title***Longitudinal changes of biochemical parameters in muscle during critical illness***

Author

Gamrin L, Andersson K, Hultman E, Nilsson E, Essén P, Wernerman J

Reference*Metabolism* 1997; **46**: 756–762

Abstract

The study was undertaken to characterize the time course of biochemical parameters in skeletal muscle during critical illness to gain information for the design of a suitable protocol for interventional studies using metabolic or nutritional manipulation. Critically ill patients in our intensive care unit ([ICU] N = 9) were investigated on two separate sampling occasions, with percutaneous muscle biopsies, for determination of protein, nucleic acids, free amino acids, energy-rich phosphates, fat, water, and electrolytes. The first biopsy specimen was taken 3 to 11 days after admission, and the second biopsy specimen 3 to 7 days later. Protein concentration, expressed as alkali-soluble protein (ASP)/DNA, decreased by 12% ($p < 0.02$) between the two biopsies. The total free amino acid content was only 50% of normal, but remained unaltered over time. In particular, the concentration of glutamine remained low, approximately 25% of normal. In contrast, branched-chain amino acid (BCAA) increased by 25% ($p < 0.05$), and phenylalanine by 55% ($p < 0.05$) between biopsies. The fat content related to fat-free solid (FFS) increased by 130% ($p < 0.001$) between the two biopsies. Muscle water did not change during the study period. The extracellular portion was double the normal value when related to FFS. Intracellular water, on the other hand, was outside the 95% confidence interval for normal values in the second biopsy. The concentrations of adenosine triphosphate (ATP), creatine, phosphocreatine, and the phosphorylated fraction of total creatine remained at the same level between the two biopsies. We conclude that in critically ill patients, there is a decrease in protein content over time, and increases in BCAA, phenylalanine, and fat content, while the low glutamine level and high extracellular water content remain unaltered. The temporal alterations were well characterized after a 5-day study period.

Citation count 28

Related references

1. Gamrin L. A descriptive study of skeletal muscle metabolism in critically ill patients: free amino acids, energy-rich phosphates, protein, nucleic acids, fat, water, and electrolytes. *Crit Care Med* 1996; **24**: 575–583.
2. Essén P. Tissue protein synthesis rates in critically ill patients. *Crit Care Med* 1998; **26**: 92–100.
3. Hammarqvist F, Lou JL, Cotgreave IA, Andersson K, Wernerman J. Skeletal muscle glutathione is depleted in critically ill patients. *Crit Care Med* 1997; **25**: 78–84.
4. Gamrin L. Protein-sparing effect in skeletal muscle of growth hormone treatment in critically ill patients. *Ann Surg* 2000; **231**: 577–586.

Key message

Muscle protein content decreases by 2%/24 hours regardless of nutritional support. In addition, muscle biochemistry shows very low concentrations of free glutamine, accompanied by elevated concentration of branched chain amino acid and aromatic amino acids. Extracellular water is doubled, as compared with normal values, and energy-rich phosphogens are also decreased. The major change over time, however, is the decrease of muscle proteins.

Why it's important

This is one study in a series of studies exploring the biochemical pathophysiology in skeletal muscle in intensive care patients. One other key reference also gives results from metabolic manipulation by providing growth hormone to ICU patients. Although the exact relationship between muscle protein depletion and morbidity/mortality has yet to be elucidated, this provides background material for hypotheses. Although muscle metabolism is not critical in a short-term perspective, for many long-term ICU patients and also former ICU patients during convalescence, muscle strength as well as muscle as a reservoir of substrates may become limiting factors.

Strengths

This was the first attempt to systematically describe muscle biochemistry in ICU patients by an invasive methodology. There is a clear demonstration as to which variables tend to vary over time. Together, these series of studies provide a considerable reference base for muscle biochemistry in ICU patients.

Weaknesses

This is, in effect, a pilot study in a limited number of patients. The patients from whom it was not possible to obtain muscle biopsy material are not included. The relationship between biochemistry and function is not clearly defined.

Relevance

A classic, in that it provides necessary information to formulate hypotheses for nutritional studies.

Title

Glutamine enriched enteral nutrition reduces infectious morbidity in multitrauma patients: a double-blind, prospective, randomized trial

Author

Houdijk APJ, Rijnsburger ER, Jansen J, Wesdorp RIC, Weis JK, McCamish MA, Teerlink T, Meuwissen SGM, Haarman HJTM, Thijs LG, van Leeuwen PAM

Reference

Lancet 1998; **352**: 772–776

Abstract

BACKGROUND: Infections are an important cause of morbidity and mortality in patients with multiple trauma. Studies in both animals and human beings have suggested that glutamine-enriched nutrition decreases the number of infections. **METHODS:** Patients with multiple trauma with an expected survival of more than 48 hours, and who had an Injury Severity Score of 20 or more, were randomly allocated glutamine supplemented enteral nutrition or a balanced, isonitrogenous, isocaloric enteral-feeding regimen along with usual care. Each patient was assessed every 8 hours for infection, the primary endpoint. Data were analyzed both per protocol, which included enteral feeding for at least 5 days, and by intention to treat. **FINDINGS:** Seventy two patients were enrolled, and 60 received enteral feeding (29 glutamine-supplemented) for at least 5 days. Five (17%) of 29 patients in the glutamine-supplemented group had pneumonia, compared with 14 (45%) of 31 patients in the control group ($p < 0.02$). Bacteremia occurred in two (7%) patients in the glutamine group, and 13 (42%) in the control group ($p < 0.005$). One patient in the glutamine group had sepsis, compared with eight (26%) patients in the control group ($p < 0.02$). **INTERPRETATION:** There was a low frequency of pneumonia, sepsis, and bacteremia in patients with multiple trauma who received glutamine-supplemented enteral nutrition. Larger studies are needed to investigate whether glutamine-supplemented enteral nutrition reduces mortality.

Citation count 252

Related references

1. Galban C, Montejo JC, Mesejo A *et al.* An immune-enhancing enteral diet reduces mortality rate and episodes of bacteremia in septic intensive care unit patients. *Crit Care Med* 2000; **28**: 643–648.

Key message

Glutamine-supplemented enteral diet in trauma patients requiring intensive care treatment lowers hospital infections.

Why it's important

This is the first study to compare a supplemented enteral diet to a conventional enteral diet in ICU patients where the supplementation is of only one substance. The patient population was

trauma patients, which makes it comparable to the studies from the United States. As might be expected in a study of this size and in this population, there was no effect upon mortality, but the morbidity measures in the study suggest that the effects of glutamine-supplemented nutrition in ICU patients are not related to the route of administration.

Strengths

Well designed protocol in a prospective study. Confined to one supplemented substance.

Weaknesses

Comparatively small, single-center study with low statistical power. This is a patient group with low mortality.

Relevance

The study demonstrates that compliance to nutritional protocol may be good enough to perform studies in enteral nutrition. Although the information given concerning the amount of administered nutrition is only indirect, the investigators seem to be reasonably successful in delivering the prescribed amount of nutrition. The results suggest that glutamine may be delivered by the enteral or parenteral route. Measures of plasma glutamine concentrations indicate that enterally provided glutamine only reaches the systemic circulation to a minor degree.

Title***A prospective, randomized, double-blind, controlled clinical trial of enteral immunonutrition in the critically ill***

Author

Atkinson S, Sieffert E, Bihari D, Guy's Hospital Intensive Care Group

Reference*Crit Care Med* 1998; **26**: 1164–1172

Abstract

OBJECTIVE: To assess the effects of enteral immunonutrition (IMN) on hospital mortality and length of stay in a heterogeneous group of critically ill patients. **DESIGN:** Prospective, randomized, double-blind, controlled clinical trial with an a priori subgroup analysis according to the volume of feed delivered in the first 72 hours of intensive care unit (ICU) admission. **SETTING:** A 13-bed adult general ICU in a London teaching hospital. **PATIENTS:** A total of 398 patients were enrolled, and data from 390 patients (IMN = 193, control = 197) were used for an intention-to-treat analysis. There were 369 patients (IMN = 184, control = 185) who actually received some enteral nutrition, of whom 101 patients (IMN = 50, control = 51) received >2.5 L within 72 hours of ICU admission. This latter group was defined as the successful 'early enteral nutrition' group. **INTERVENTIONS:** Within 48 hours of ICU admission, patients were randomized to receive either the IMN Impact (Novartis Nutrition), an enteral feed supplemented with arginine, purine nucleotides, and omega-3 fatty acids, or an isocaloric, isonitrogenous, control enteral feed. **MEASUREMENTS AND RESULTS:** There was no significant difference in hospital mortality rate between the two groups on an intention-to-treat analysis (Impact group 48%, control group 44%), nor in any other predefined subgroup analysis. However, patients randomized to receive the IMN had higher Acute Physiology and Chronic Health Evaluation II scores (20.1 +/- 7.1 vs. 18.7 +/- 7.1 [p = 0.07] intention-to-treat [n = 390]; 20.1 +/- 7.2 vs. 18.5 +/- 7.1 [p = 0.04] received feed [n = 369]). Of the 101 patients achieving early enteral nutrition, those patients fed with the IMN had a significant reduction in their requirement for mechanical ventilation compared with controls (median duration of ventilation 6.0 and 10.5 days, respectively, p = 0.007), with an associated reduction in the length of hospital stay (medians 15.5 and 20 days, respectively, p = 0.03). **CONCLUSION:** While the administration of enteral IMN to a general, critically ill population did not affect mortality, those patients in whom it was possible to achieve early enteral nutrition with Impact had a significant reduction in the morbidity of their critical illness.

Citation count

120

Related references

None

Key message

In a comparatively large study in ICU patients, only the group that was adequately fed, which was less than one third of included patients, showed an improvement in morbidity related to the immune-enhanced diet.

Why it's important

In a comparatively large study in one ICU focusing upon enteral nutrition, it was demonstrated that enteral nutrition tends to be insufficient for the majority of patients.

Strengths

1. More or less consecutive patients.
2. A population that is representative of European intensive care units.
3. A clear and honest declaration of the amounts of nutrition actually given.

Weaknesses

A failure to deliver prescribed amount of nutrition, which basically makes the study 'uncontrolled' in the sense that the treatment evaluated was actually not delivered. The high rate of mortality in a population necessitates a strategy that considers not only differences, but also lack of differences in mortality rates between groups. This is not taken care of in the protocol.

Relevance

The study is perhaps not conclusive in its primary outcome parameter. Nevertheless, it represents an important achievement in completing this type of study in ICU patients; it highlights both difficulties and possibilities in that field. It has contributed in that it is necessary to evaluate nutritional treatment in this way in ICU patients.

Fluids

Malcolm Fisher

Introduction

It is impossible to imagine daily critical care practice without intravenous fluids, yet as a safe and dependable form of treatment, it is a relatively new phenomenon. The need for fluid administration and its importance has been recognized since ancient times, but the ancients had no recourse to intravenous administration. Fluids of various kinds, particularly blood, have fascinated the medical fraternity for centuries – for both medical and non-medical purposes. The first documented use of blood transfusion was in dogs in 1666 by Richard Lower, and this led to use in man by Jean Baptiste Denis in 1667. He was the physician to Louis XIV, and in his first attempts he used lambs' blood. This appeared to 'work' in the first patient, but then the next two died. The documentation is vague; however, it has been suggested that the cause of the deaths and in particular the issue of incompatibility might have been a major subject of discussion during 1668, but whether this occurred and what the conclusions were are not known. Not surprisingly, the method fell into disrepute. It was then almost 150 years before J. Blundell reported in 1818 on the first successful transfusion of human blood. This was performed at St Thomas Hospital for a parturient. Vein to vein transfusion was described by James Hobson Aveling in 1819, and autotransfusion, introduced in 1874, was in common use at the end of the nineteenth century. At the time of World War I, anesthesiologists such as G.W. Crile began involving themselves in maintaining patients' hemodynamic status.

There was also growing interest in the use of fluids other than blood. Saline was first used in 1891 for the treatment of shock. A few years later the more 'physiological' 'Hartmans' solution, was hailed as a great advance. Technical advances in fluid administration spawned devices such as the drip chamber, which appeared in about 1909.

The first plasma substitutes were made from gum acacia in 1919, and polyvinyl pyrrolidone was developed in the 1940s by Helmut Wesse. The advent of plastics facilitated intravenous access and fluid administration, and led to the development of a range of new colloids, including the gelatins, dextrans, and starches. With these advances came the debate addressing the benefits of crystalloid versus colloid solutions, which shows no signs of abating some 40 years later! More recent advances include hypertonic solutions, and colloids formulated in a physiological medium.

The unraveling of the physiology of fluids and the interaction with the pathophysiology of the shock states has been instrumental in the development of fluid therapy. Argument continues as to how these fluids should be administered, and the nature of the fluid that should be given in different situations. Despite the obvious observation that various fluids are given on a daily basis and are a fundamental part of management of the critically ill, there are few hard data looking at anything beyond the short-term intravascular expansion properties of these fluids. There are few areas of medicine where such routine management has produced so much controversy based on so little fact. Therefore, the classics chosen are not related to specific fluids, but rather those that have influenced conceptual advances in this field and have thereby contributed to the current wide variation in practice.

Title

On the absorption of fluids from the connective tissue spaces

Author

Starling EH

Reference

J Physiol 1896; **19**: 312–326

Abstract

Not available

Summary

A series of experiments in dogs showed that:

1. Salt solutions, isotonic with the blood plasma, can be and are absorbed directly by the blood vessels. This statement probably holds good for dropsical fluids containing small percentages of proteins.
2. A backward filtration into the vessels is mechanically impossible in the connective tissues of the limbs, of the muscles, and of the glands similar in structure to the sub-maxillary glands.
3. The proteids of serum have an osmotic pressure of about 30–40 mmHg. Absorption of isotonic salt solutions by the blood vessels is determined by this osmotic pressure of the serum proteins. The same factor is probably responsible for the absorption from the tissues which ensues on any general lowering of capillary pressures, e.g. artificial anemia.
4. The proteids of the tissue fluids, when not used up in the tissues themselves, are probably absorbed mainly, if not exclusively, by the lymphatic system.

Citation count 1163

Related references

1. Civetta JM. A new look at the Starling Equation. *Crit Care Med* 1979; **7**: 84–91.
2. Guyton AC, Batson HM, Smith CM. Adjustments of the circulatory systems following very rapid haemorrhage. 1951; **164**: 351–359.

Key message

Crystalloid solutions flow into the interstitial space. This paper established the dynamic equilibrium between the fluid in the capillary and the fluid in the extracellular space, and the role of the lymphatic system in maintenance of fluid homeostasis.

Why it's important

The paper is important because it describes the fundamental principle that has underwritten the major controversies in critical care and resuscitation, many of which remained unresolved over the subsequent 100 years. These include the crystalloid versus colloid controversy, and the wet or dry controversy. The paper by Civetta cited as a supplementary

paper is important in understanding the limitations of 'Starling's Law of the Capillary', particularly as it applies to the lung.

Strengths

The paper reflects the meticulous experimental technique and thinking of Starling.

Weaknesses

The major weakness in the Starling hypothesis is that it is variable in different tissues and species, as are various other important factors (particularly capillary permeability), and is dependent on measurement techniques (see paper by Civetta cited above).

Relevance

The dynamic equilibrium between the vascular and extravascular compartments in fluid therapy has an important role in compensation for blood loss. The body response to hemorrhage, of shifting fluid from the extravascular gel to the vascular compartment, is one that can easily be maneuvered by the administration of isotonic fluid intravenously. The Starling mechanism and its relevance are the basis of the major controversies in fluid therapy over the subsequent hundred years, in particular, the appropriate fluid in resuscitation, and the 'wet or dry' controversy.

Title

Continuous drip blood transfusion

Author

Marriott HL, Kerwick A

Reference

Lancet 1935; **1**: 977–981

Abstract

Not available

Summary

In a series of patients, blood was infused by continuous drip infusion using rubber tubing and a glass cannula, replacing the roller pump and direct transfusion. The blood was oxygenated by bubbling oxygen through the reservoir. A volume of 5620 ml was the largest amount given, and four patients who benefited from the infusion are described.

Citation count 40

Related references

1. Hebert PC, Wells G, Blajchman MA *et al.* and the Tranfusion requirements in Critical Care Investigators for the Canadian Critical Care Group. A multicenter, randomised, controlled trial of transfusion requirements in critical care. *N Engl J Med* 1999; **340**: 409–417.

Key message

Controlled blood transfusion may achieve 'brilliant results'.

Why it's important

This was the start of blood transfusion as we know it. Based on largely anecdotal reports, and lacking the contemporary clinical trial approach, it pioneered a clinical practice that revolutionized resuscitation.

Strengths

The major strength of the paper is that it describes meticulous attention to the prevention of sepsis in preparation of infusion, delivery, and cannulation.

Weaknesses

The main weakness of the paper is that its advocacy of blood transfusion is based on a series of anecdotes – albeit amusing.

Relevance

Blood transfusion has been a major advance in saving and maintaining life. This is the first paper I can find that looks at the techniques and indications and provides anecdotal

evidence of efficiency. The indications for transfusion therapy and the end-points have been major discussion points since. The supplementary paper by Hebert *et al.* is the latest in this discussion, suggesting that in critically ill patients, increasing the hemoglobin levels to > 80 g/L does not improve outcome, which has a major importance in this millennium when the risk of blood transfusion-related disease is increased.

Title

Effect of elevated left atrial pressure and decreased plasma protein concentration on the development of pulmonary oedema

Author

Guyton AC, Lindsey AW

Reference

Circ Res 1959; **7**: 649–657

Abstract

Not available

Summary

In 97 dogs, left atrial pressure was elevated to various levels up to 50 mmHg by partial constriction of the aorta. The effect of these pressures for from 30 min to 3 hours on the accumulation of lung edema was then studied. Edema was estimated by determining the ratio of the weight of the wet lung to the weight of the same lung after drying. In animals with normal plasma protein concentrations, fluid began to transude into the lungs when the left atrial pressure rose above an average of 24 mmHg. In another series of animals the plasma protein concentrations were reduced by plasmapheresis at the beginning of each experiment until the plasma protein concentration averaged 47% of the control value. Fluid began to transude into the lungs of these animals when the left atrial pressure rose above a critical value of 11 mmHg. Furthermore, the rate at which fluid accumulated in the lungs, in all series of experiments, was directly proportional to the rise in left atrial pressure above the critical pressure at which fluid began to collect in the lungs.

The effect of prolonged elevation of left atrial pressure on the development of pulmonary edema in dogs has been studied under several conditions. In one series, the left atrial pressure was elevated for 30 minutes to values between 0 and 45 mmHg. By studying lung weight to body weight ratios, it was shown that atrial pressures below 24 mmHg did not cause significant transudation of fluid from the pulmonary capillaries, but left atrial pressures above this value caused fluid transudation at rates directly in proportion to the additional rise in pressure.

In similar studies in another series, the left atrial pressure was maintained at elevated levels for as long as 3 hours. No animals died of pulmonary edema as long as the left atrial pressure was ≤ 24 mmHg. All animals with left atrial pressures of ≥ 26 mmHg failed to survive the full 3 hours of elevated pressure.

In an additional series of animals, the plasma protein concentration was first decreased by about one half of normal, and the left atrial pressure was then elevated for prolonged periods of time. In this series, no edema appeared when the left atrial pressure was < 12 mmHg, but edema appeared in the other animals in proportion to the additional rise in pressure above the 12 mmHg mark.

In the dogs with normal plasma proteins and with diminished plasma proteins, the rates of fluid transudation into the lungs were 0.21 and 0.22 g/mmHg, respectively, of dry weight of lung tissue, in which mmHg is expressed as the actual left atrial pressure minus the critical pressure point at which edema began to appear.

Citation count 500

Related references

1. Sten L, Barand JJ, Morisette M, da Luz P, Weit MH. Pulmonary oedema during volume infusion. *Circulation* 1975; **52**: 483–489.
2. Laks H, O'Connor NE, Anderson W, Pilon RN. Crystalloid versus colloid haemodilution in man. *Surg Gynecol Obstet* 1976; **142**: 506–512.
3. Zadrobilek E, Hackl W, Sporn P, Steinbereithner K. Effect of large volume replacement with balanced electrolyte solutions on extravascular lung water in surgical patients with sepsis syndrome. *Intensive Care Med* 1989; **15**: 505–510.

Key message

Pulmonary edema is related to hydrostatic pressure and colloid osmotic pressure, and a lower colloid osmotic pressure facilitates edema formation in the lung.

Why it's important

In this paper, Guyton and Lindsay apply the Starling equation to the lung in intact dogs, and suggest the importance of both colloid osmotic pressure and right atrial pressure in oedema formation, and that the processes in the lung are similar to those in the systemic circulation. They also show the interaction that may take place, and introduce the concept of a critical pressure comprised of both components at which fluid flux will occur. This has become the cornerstone of much fluid management.

Strengths

The initial Starling study was restricted to peripheral tissues. Guyton and Lindsay have applied the Starling principle to the lung. They clearly demonstrated the physiological principles underlying fluid movement across the lung under physiologically defined circumstances and provided an *in vivo* 'proof' of Starling's equation.

Weaknesses

These are largely the weaknesses in subsequent interpretation, rather than in the studies themselves. The findings did not necessarily correlate with later clinical studies. Subsequently, Sten *et al.* (1) showed that in hypovolemic patients, maintenance of colloid osmotic pressure without elevation of left ventricular filling pressure (LVFP) did not lead to pulmonary edema. Five of 16 patients who received colloid and had an elevated LVFP, but no reduction in plasma colloid osmotic pressure, developed pulmonary edema. Eleven patients resuscitated with crystalloid, who had a fall in colloid osmotic pressure but normal LVFP, developed pulmonary edema.

Laks *et al.* (2) compared preoperative hemodilution with Ringers lactate in four patients to a previous group hemodiluted with plasmanate, and found an increase in lung water in the colloid Ringers group and a reduction in lung water in the plasmanate group. Denby, Marlar and Will showed that crystalloid resuscitation made the septic lung more susceptible to oedema. However, Zadrobilek *et al.* (3) could find no relationship between decrease in colloid osmotic pressure and lung water in adult surgical patients with sepsis syndrome. This highlights the problems of extrapolating controlled physiological studies of specific insults, such as hypovolemia or acute hypoproteinemia, to different pathophysiological mechanisms, such as sepsis. The weakness is therefore in the excessively enthusiastic extrapolation of the findings to widely disparate clinical situations.

Relevance

These studies provided the theoretical basis of fluid management on which much subsequent clinical practice was based. The importance of hemodynamics, and of their measurement, was introduced into clinical practice. In some respects, this study encouraged the subsequent explosion in invasive monitoring techniques which radically altered our perception of fluids and their uses in both resuscitation and maintenance.

Title***The effects of haemorrhage on body composition***

Author

Moore FD

Reference*N Engl J Med* 1965; **273**: 567–577

Abstract

Not available

Summary

Bodily changes in man, after venous hemorrhage of 500–1000 ml, are reviewed. Understanding and interpretation of these changes have been enlightened by recent data on the endocrine and visceral responses to isotonic volume reduction.

Non-shock-producing venous hemorrhage is a sharp challenge to the autoregulation of body composition. It results in the net movement of water, salt, and protein into the plasma. In man, this plasma volume refill occupies a period of 20–40 hours. Its rate curve is one of constantly decreasing magnitude. Initial rates as high as 2 ml/min are observed. The final volume of refill accurately restores the blood volume to normal, the volume of new plasma equalling the sum of erythrocytes and plasma withdrawn. With completion of refill, these events cease and a steady state is resumed; circulatory adequacy has been restored, although body compositional ratios remain distorted.

During the period of refill, there are readily demonstrable alterations in the renal handling of sodium and water, and, in association with these visceral changes, an increase in the urinary excretion of aldosterone and blood level of antidiuretic hormone. There is an early increase in erythropoietin in both plasma and urine.

The initial distortion of body composition may be characterized as a lowering of the plasma volume:interstitial fluid ratio below its norm of 0.23; this gradually increases during refill, until at completion the value is elevated, upwards of 0.35, depending on the volume of the blood loss. Interstitial fluid is then restored to normal by the injection or ingestion of water and salt; with the completion of this process, volume-conserving activity appears to cease.

Under circumstances of salt infusion during the refill phase, one can demonstrate a continued inward current of albumin despite a brisk dispersal of water and ions outward from the plasma volume. This finding favors the view that anatomic sites for the passage of water with small molecules, as opposed to macromolecules, are distinct in the capillary or post-capillary venule. The time sequence of the appearance of new albumin in the circulation suggests that the early rapid phase involves the appearance of preformed albumin from extravascular sites. The subsequent slow ingress of new albumin at a much slower rate suggests the appearance of albumin that has been newly synthesized in the liver.

The post-hemorrhagic state modifies the pharmacology and metabolism of infused substances; studies on norepinephrine, angiotensin, mannitol, balanced salt, and whole blood are reviewed.

Of notable importance in the autoregulation of the blood volume are the responses of two specialized masses of tissue lying on both sides of the spine, and anatomically located

in the adrenal glands and kidneys. These consist particularly of the zona glomerulosa and the medulla of the adrenal glands, and, in the kidneys, the glomerulotubular excretory apparatus, the renal arterial supply, the juxtaglomerular apparatus, and the macula densa, and an unidentified cellular component responsible for the production of erythropoietin.

Citation count 98

Related references

1. Moore FD, Haley HB, Bening EA, Brooks L, Edelmann IS. Future observations on total body water. *Surg Gynecol Obstet* 155–179.
2. Moore FD, Ball MB. *The Metabolic Response to Surgery*. Springfield, IL: Charles C Thomas, 1952.

Key message

The body retains salt and water when stressed.

Why it's important

The studies of Moore and colleagues first qualified the stress response in man, particularly the retention of sodium and water after injury. This formed the basis of resuscitation practice and the evolution of various means of reducing salt and water retention in the early phases of resuscitation. This concept is seen in new techniques such as the use of hypertonic solutions in the resuscitative phase.

Strengths

The paper is the summary of an impressive series of studies which began from the classic Moore and Ball book describing a response to blood loss, later extended to the majority of stressed states.

Weaknesses

The paper is a review.

Relevance

The Moore studies were the scientific basis for the 'dry' school of fluid therapy. The 'dry' school believed that the physiological response was one that should be used to guide the form of therapy the body favored, and as the body retained sodium and fluid, therapy should emulate the body process. Moore believed that the reason for this was teleological: our ancestors needed to retain salt and water and metabolize protein when they could not gather food.

Title

Acute changes in extracellular fluids associated with major surgical procedures

Author

Shires T, Williams J, Brown F

Reference

Ann Surg 1961; **154**: 803

Abstract

Not available

Summary

Patients undergoing minor operative surgery were used as controls, and patients undergoing major operations were studied as experimental subjects in measurements of acute changes in body fluid equilibria during the operative procedure.

The technique employed was a new method for the simultaneous measurement of plasma volume, red blood cell mass, and extracellular fluid volume so designed that these volumes could be measured on two occasions during the operative period. This consisted of the use of I¹³¹ (RISA)-tagged serum albumin, Chromate⁵³-tagged red blood cells, and S³⁵ sodium sulphate, with re-injection of all isotopes after 2 hours.

The data indicated that marked reduction in functional extracellular fluid occurred during a major operative procedure.

The magnitude of the internal redistribution of extracellular fluid was not related to whole blood loss, but seemed to be directly related to the degree of surgical trauma, from the standpoint of degree and duration of retraction and ease of operative exposure.

These data support the hypothesis that a major stimulus to postoperative limitations of sodium excretion is an acute contraction of functional extracellular fluid incurred by the surgical procedure itself.

Citation count 261

Related references

1. MacKenzie AI, Donald JR. Urine output and fluid therapy during anaesthesia and surgery. *BMJ* 1969; **3**: 619–622.
2. Cleland J, Pluth JR, Tauxe WN, Kirklin JW. Blood volume and body fluid compartment changes seen after closed and open cardiovascular surgery. *J Thorac Cardiovasc Surg* 1996; **52**: 698.

Key message

The reason for the retention of sodium and water described by Moore is a functional loss of extracellular fluid, which produces a state akin to dehydration.

Why it's important

This is one of the basic studies producing the 'wet' school of thought, which was a swing away from the dictums of Moore. It was believed that 'sustained hydration' would overcome the salt and water retention.

Strengths

The strength of the studies lay in the fact that they were human studies, and direct measurement was involved.

Weaknesses

The 20-minute radiosulfate space almost certainly overestimated the magnitude of the 'third space', as Cleland and others showed.

Relevance

This study began the Ringer's lactate tide that engulfed the United States, and is still favored by many as the correct approach to fluid therapy.

Title

Donor blood and isotonic salt solution: effect on survival after haemorrhagic shock and operation

Author

Wolfman KF, Neill SA, Heaps DK, Zuidema GD

Reference

Arch Surg 1963; **86**: 869–873

Abstract

Not available

Summary

Five groups of 10 dogs were submitted to a 2-hour period of hemorrhagic shock and operative trauma. Those animals treated by re-infusion of the blood previously removed, with or without the addition of donor dog blood, each had a mortality rate of 80% within 24 hours. Dogs infused with isotonic lactated Ringer's solution before the re-infusion of autologous or homologous blood had a 24-hour mortality rate of 0% and 10%, respectively. The administration of 5% dextrose before re-infusion of autologous blood was accompanied by a 24-hour mortality rate of 50%, and this gradually rose to 80% by the end of 72 hours.

It is concluded that the maintenance of the normalcy of the effective volume of the extracellular fluid, by the cautious administration of isotonic salt solutions, enhances survival in dogs submitted to a period of hemorrhagic shock and operative trauma.

Citation count 35

Related references

1. Rush BF, Morehouse R. Volume replacement following acute bleeding compared to replacement after haemorrhagic shock: effectiveness of dextran and buffered saline. *Ann Surg* 1967; **62**: 88–96.
2. Takaori M, Safar P. Treatment of massive hemorrhage with colloid and crystalloid solutions. *JAMA* 1967; **199**: 297–302.
3. Carey JS, Scharschmidt, BF, Culliford F, Greenlee JE, Scott AR. Hemodynamic effectiveness of colloid and electrolyte solutions of replacement of simulated operative blood loss. *Surg Gynecol Obstet* 1970; **131**: 679–686.

Key message

Salt solutions and fresh blood are more effective volume replacement regimes than blood alone.

Why it's important

This was the first of many studies showing that crystalloid and blood were more effective in treating hemorrhage than blood alone, and gave further impetus to the crystalloid resuscitation enthusiasts.

Strengths

Wolfman's study was interesting in that it was one of the few that used donor blood as well as shed blood.

Weaknesses

The weaknesses in this study become apparent when paper no. 8 (Mitchell *et al.* 1992) is considered. The model is probably relevant to elective surgery, but the extrapolation of the data to hemorrhagic shock may not be valid, as continuing losses occur.

Relevance

The series of studies that were similar to this are the fundamental basis of resuscitating hypovolemic patients with fluids other than blood, and the demonstration of the relative tolerance of low hematocrit if volume is maintained. The crystalloid versus colloid controversy has its origins in such studies: virtually every study in non-septic bled animals showed that colloid and blood was superior to crystalloid and blood.

Title

Ringers lactate solution and extracellular volume in the surgical patient: a critical analysis

Author

Roth E, Lax LC, Maloney JV

Reference

Ann Surg 1969; **169**: 149–164

Abstract

Not available

Summary

Since the classic work of Moore and associates, salt and water therapy has been based upon the recognized hormonal and metabolic responses of the body to the stress of surgical operation. On the basis of that work, moderate restriction of water and sodium has been recommended; this has been followed by most surgeons. Recently, several groups of investigators have recommended that a large amount of Ringer's lactate solution be administered to patients during operation, and for treatment of hemorrhagic shock. This recommendation is based upon the finding of a deficit in extracellular fluid volume in animals in shock and in man following an operation. An experimental and clinical study was therefore carried out to determine this radical alteration in therapeutic principles, as justified on the basis of available evidence.

A series of 50 patients undergoing cholecystectomy in the years 1963–1969 was studied with regard to the administration of salt and water during operations. During this 5-year period, there was a progressive increase in the salt and water loading of patients, so that those operated upon in 1967 received twice the amount of water and 11 times the amount of sodium ion as those operated on in 1963. It was the authors' clinical impression that, although most patients tolerated this treatment well, even healthy non-cardiac patients occasionally developed massive pulmonary edema without apparent cause other than the water and sodium loading.

Extracellular fluid volume was measured with radiosulphate in a series of dogs before and after subjection to hemorrhagic shock. There was a mean decrease in extracellular fluid volume of 5.7% after 1–1.5 hours of profound shock following hemorrhage, with the animals maintained at a mean arterial pressure of 50 mmHg. This small deficit (equivalent to 696 ml in a 60-kg man) is probably not a real deficit, but is accounted for by removal of blood samples, transpiration, and urine formation during the experiment. The discrepancy between this finding and the reports of others can be explained by: (a) the single-sample radiosulphate dilution method used by other investigators, which contains an inherent error and leads to the determination of an apparent, but erroneous, ECF deficit; (b) the failure of some investigators to account for the volume of extracellular fluid lost in the shed blood; and (c) errors introduced in the measurement of extracellular fluid because of incomplete mixing of the tracer owing to the 'dead-leg syndrome', which follows cannulation of the femoral artery in dogs in hemorrhagic shock.

Extracellular fluid volume was measured in a series of nine patients undergoing open-heart surgical procedures, and eight patients undergoing major general surgical operations. An increase in extracellular fluid volume was demonstrated. In the cardiac patients,

extracellular fluid volume increased by 9.0%, and interstitial fluid volume increased by 13.5%. In the general surgical patients, extracellular fluid volume increased by 15.5%, and interstitial fluid volume increased by 22.8%. When correction was made for intravenous fluids administered, and for urinary excretion of fluid during the course of the study, there was no change in postoperative extracellular fluid volume in either the cardiac patients (−0.6%) or the general surgical patients (+0.2%).

Ringer's lactate solution may be of theoretical benefit in treatment of the metabolic acidosis that accompanies profound hemorrhagic shock. The restoration of plasma pH to normal permits the myocardium to respond to the positive inotropic effects of endogenous catecholamines, and may improve the circulation. Unfortunately, Ringer's lactate is a poor choice as buffer, as it is not effective until lactate has been metabolized in the liver. The high level of plasma lactate that characterizes hemorrhagic shock is evidence of the inability of the liver to metabolize lactate in the presence of a deficient blood flow. Clinical experience suggests that buffering ions that are immediately effective, such as bicarbonate, are superior to lactate in correcting the metabolic acidosis of shock.

The study of inter-compartmental fluid shifts in the body during shock and during surgical operations provides an interesting and valuable avenue of investigation in the effort to improve the care of surgical patients. In particular, further study of the effect of altered hydrogen ion concentration on the chemical reactivity of long chain protein molecules in the extracellular space seems promising. However, both theoretical considerations and laboratory data suggest that the size of the inter-compartmental fluid shift, which accompanies the metabolic acidosis of shock, may be neither as large in magnitude nor as significant as that reported by other investigators. It is upon such reports that the current therapeutic use of massive amounts of Ringer's lactate solution is based.

It is concluded that until such time as scientifically acceptable evidence of a deficit in extracellular fluid volume in shock and during operation is presented, consideration of the extracellular fluid volume should not serve as the basis for loading patients with salt and water. It was the authors' impression that the current interest in Ringer's lactate solution would have served as a valuable stimulus to the re-evaluation of current methods of fluid therapy. They support fully the view expressed by Moore and Shires '... the surgeon should carry on with his established habits of careful assessment of the patient's situation, the losses incurred, and the physiologic needs in replacement. The objective of care is restoration to normal physiology and normal function of organs, with a normal blood volume, functional body water, and electrolytes. This can never be accompanied by inundation'.

Citation count 103

Related references

None

Why it's important

Anecdotes from the Korean war, which were repeated in the Vietnam war, suggested that the use of high volume crystalloid resuscitation may produce pulmonary edema. This paper first studied scientifically the suggestions that Ringer's lactate solution may be responsible for pulmonary edema occurring postoperatively. The supplementary papers emphasise that the antidiuretic hormone response to surgery is not 'turned off' by fluid loading.

Strengths

The study is impressive in that three individual studies were performed to address the question of the relationship between fluid infusion and pulmonary edema, one in animals and two in patients.

Weaknesses

The number of patients studied was small.

Relevance

The work supports the previously cited studies suggesting that the 'third space' is of less relevance than suggested in the original Shires' paper, and questions the benefits of ECF expansion.

Title

Improved outcome based on fluid management in critically ill patients requiring pulmonary artery catheterization

Author

Mitchell JP, Schuller D, Calandrino FS, Schuster DP

Reference

Am Rev Respir Dis 1992; **145**: 990–998

Abstract

We performed a randomized, prospective trial to evaluate whether fluid management that emphasized diuresis and fluid restriction in patients with pulmonary edema could affect the development or resolution of extravascular lung water (EVLW), as well as time on mechanical ventilation, and time in the intensive care unit (ICU), in critically ill patients requiring pulmonary artery catheterization (PAC). PAC was performed on 101 patients. A total of 52 patients were randomized to an EVLW management group using a protocol based on bedside indicator-dilution measurements of EVLW. The other 49 patients were randomized to a wedge pressure (WP) management group in whom fluid management decisions were guided by WP measurements. A total of 89 patients had pulmonary edema (defined as EVLW greater than 7 ml/kg ideal body weight). Except for a clinically unimportant difference in mean age, the two groups were entirely comparable at baseline. The study groups were managed differently, as evidenced by cumulative input-output of 2,239 +/- 3,695 ml (median = 1,600 ml) in the WP group versus 142 +/- 3,632 ml (median = 754 ml) in the EVLW group (p = 0.001). EVLW decreased significantly, and ventilator-days and ICU days were significantly shorter only in patients from the EVLW group. No clinically significant adverse effect occurred as a result of following the EVLW group algorithm. Thus, a lower positive fluid balance, especially in patients with pulmonary edema regardless of cause, is associated with reduced EVLW, ventilator-days, and ICU days.

Citation count 225

Related references

1. Sladen A, Laver MB, Pontopiddan HN. Pulmonary complications and water retention in prolonged mechanical ventilation. *N Engl J Med* 1968; **279**: 448–453.
2. Schuller D, Mitchell JP, Calandrino FS, Schuster DP. Fluid balance during pulmonary oedema. Is fluid gain a marker or a cause of poor outcome? *Chest* 1992; **100**: 1068–1075.

Key message

A positive fluid balance, especially in patients with pulmonary edema, increases ICU stay.

Why it's important

The paper confirms the authors' previously speculative study and the observational study of Sladen *et al.* (1) indicating that a positive water balance is detrimental to intensive care patients.

Strengths

The study is a prospective randomized human study.

Weaknesses

In a study of effects of fluid balance, the end-point of a wedge pressure of 17 mmHg may be excessive.

Relevance

This study reinforces the message of the Shires and Moore editorial 'Moderation' cited in the previous classic paper. The paper is strongly in support of the 'dry' school of fluid therapy, as opposed to the 'wet' school.

Title

Immediate versus delayed fluid resuscitation for hypotensive patients with penetrating torso injuries

Author

Bickell WH, Wall MJ Jr, Pepe PE, Martin RR, Ginger VR, Allen MK, Mattox KL

Reference

N Engl J Med 1994; **331**: 1105–1109

Abstract

BACKGROUND. Fluid resuscitation may be detrimental when given before bleeding is controlled in patients with trauma. The purpose of this study was to determine the effects of delaying fluid resuscitation until the time of operative intervention in hypotensive patients with penetrating injuries to the torso.

METHODS. We conducted a prospective trial comparing immediate and delayed fluid resuscitation in 598 adults with penetrating torso injuries who presented with a pre-hospital systolic blood pressure of ≤ 90 mmHg. The study setting was a city with a single centralized system of pre-hospital emergency care and a single receiving facility for patients with major trauma. Patients assigned to the immediate-resuscitation group received standard fluid resuscitation before they reached the hospital and in the trauma center, and those assigned to the delayed-resuscitation group received intravenous cannulation, but no fluid resuscitation until they reached the operating room.

RESULTS. Among the 289 patients who received delayed fluid resuscitation, 203 (70 percent) survived and were discharged from the hospital, as compared with 193 of the 309 patients (62 percent) who received immediate fluid resuscitation ($p = 0.04$). The mean estimated intraoperative blood loss was similar in the two groups. Among the 238 patients in the delayed-resuscitation group who survived to the postoperative period, 55 (23 percent) had one or more complications (adult respiratory distress syndrome, sepsis syndrome, acute renal failure, coagulopathy, wound infection, and pneumonia), as compared with 69 of the 227 patients (30 percent) in the immediate-resuscitation group ($p = 0.08$). The duration of hospitalization was shorter in the delayed-resuscitation group.

CONCLUSIONS. For hypotensive patients with penetrating torso injuries, delay of aggressive fluid resuscitation until operative intervention improves the outcome.

Citation count

549

Related references

1. Bickell WH, Shaftan GW, Mattox KL. Intravenous fluid administration and uncontrolled hemorrhage. *J Trauma* 1989; **29**: 409.

Key message

There are a group of patients who, after penetrating trauma with 'stable hypotension', do not benefit from fluid therapy in an attempt to raise their blood pressure.

Why it's important

This paper is a carefully planned and difficult study to test the hypothesis in the cited supplementary paper that there is no clinical correlation between the controlled blood withdrawal of earlier experiments and vessel disruption with acute and continuing hemorrhage. A group of patients were identified who were stable after penetrating trauma, and if fluid therapy in these patients was delayed the outcome improved.

The hypothesis of Cannon in 1918 that fluid administration before surgical intervention may increase bleeding, and may increase blood loss by increasing blood pressure and removing clots, appears to be substantiated. It is important to note that patients with life-threatening shock were not included in the study.

Strengths

The study was probably as well designed as is possible, and is randomized.

Weaknesses

Questions were raised about the validity of the alternate day randomization, the analysis, and the fact that the total volume of fluid was the same in both groups. It does not address the question of appropriate management in patients who have longer times from accident to definitive surgery.

Relevance

The relevance of the study is that volume resuscitation in patients with penetrating trauma should not delay surgery. The study was undertaken in an area with the ability to transport patients rapidly to the Emergency Room, and does not apply to blunt trauma. The study suggests a need to refine triage criteria to determine who will, and who will not, benefit from fluid resuscitation before surgery.

Title

Human albumin administration in critically ill patients: systematic review of randomised controlled trials

Author

Cochrane Injuries Group Albumin Reviewers

Reference

BMJ 1998; **317**: 235–240

Abstract

Objective. To quantify effect on mortality of administering human albumin or plasma protein fraction during management of critically ill patients.

Design. Systematic review of randomized controlled trials comparing administration of albumin or plasma protein fraction with no administration, or with administration of crystalloid solution in critically ill patients with hypovolemia, burns, or hypoalbuminemia.

Subjects. 30 randomized controlled trials including 1419 randomized patients.

Main outcome measure. Mortality from all causes at end of follow up for each trial.

Results. For each patient category, the risk of death in the albumin treated group was higher than in the comparison group. For hypovolemia, the relative risk of death after albumin administration was 1.46 (95% confidence interval 0.97 to 2.22), for burns, the relative risk was 2.40 (1.11 to 5.19), and for hypoalbuminemia, it was 1.69 (1.07 to 2.67). Pooled relative risk of death with albumin administration was 1.68 (1.26 to 2.23). Pooled difference in the risk of death with albumin was 6% (95% confidence interval 3% to 9%), with a fixed effects model. These data suggest that for every 17 critically ill patients treated with albumin, there is one additional death.

Conclusions. There is no evidence that albumin administration reduces mortality in critically ill patients with hypovolemia, burns, or hypoalbuminemia, and a strong suggestion that it may increase mortality. These data suggest that use of human albumin in critically ill patients should be urgently reviewed, and that it should not be used outside the context of rigorously conducted, randomized controlled trials.

Citation count

428

Related references

1. Schierhout G, Roberts I. Fluid resuscitation with colloid or crystalloid solutions in critically ill patients: a systematic review of randomised trials. *BMJ* 1998; **316**: 961–964.
2. Velanovich V. Crystalloid versus colloid fluid resuscitation: a meta-analysis of mortality. *Surgery* 1989; **105**: 65–71.
3. Moran J, Worthley LIG. Albumin and resuscitation: a sense of déjà vu. *Crit Care Resus* 1999; **1**: 110–112.
4. Cochrane Injuries Group, Department of Epidemiology and Public Health, Institute of Child Health, London WC1N 1EH.
5. Comment. In: *BMJ* 1998; **317**: 223–224, 240, 343.

Key message

Albumin is lethal, causing one additional death in every 17 patients.

Why it's important

The paper is important because it illustrates many of the adverse events that may be associated with what is probably bad science. The paper was released to great publicity before publication, and sparked a reaction that was both emotive and analytical. It was used by government bodies and hospital executives as a potential money saver, and led to the classic comment by one of the Cochrane Workers that if given albumin even as part of a trial, he would sue.

Its greatest importance is that in an era where meta-analysis was being elevated to a status close to the Ten Commandments as a driver of practice, this meta-analysis illustrated more than any other that meta-analysis is a tool to generate hypotheses to be tested, not to determine practice guidelines. The cost of the Australian study to verify or refute the hypothesis of this study will be of the order of \$A7,000,000.

Strengths

The meta-analysis was carried out rigorously, according to the published principles.

Weaknesses

The studies analyzed were small and from diverse groups, from burn patients to patients given albumin to raise albumin levels. The inclusions and exclusions were criticized strongly. The subsequent crystalloid versus colloid meta-analysis and the earlier meta-analysis by Velanovich (2), did not support the study's findings. Moran and Worthley (3) make the interesting point that plasmapheresis with albumin was associated with 12 deaths in 16,603 procedures in two studies.

Relevance

The paper is relevant because of the associated controversy, and the essential lesson it teaches that most experts may find results from analyzing poor, small, and diverse studies to be suspicious, and that meta-analysis should generate hypotheses rather than dictate practice.

Infection in the intensive care unit

Dennis G. Maki

Introduction

Intensive care units (ICUs) have contributed significantly to the outcome of patients with trauma, shock states, and other life-threatening conditions, but are associated with a greatly increased risk of nosocomial (hospital-acquired) infection. Rates of nosocomial infection in patients requiring >1 week of advanced life support within an ICU are 3–5-fold higher than in hospitalized patients who do not require ICU care, and approach 20–25%. Sepsis – occasionally from community-acquired infection, more often from infection acquired in the ICU – is the most frequent cause of multiple-organ dysfunction syndrome, and the leading cause of death in non-coronary care ICUs in the USA at the present time.

Over the past two decades, there has been a marked increase in the resistance to antibiotics of organisms causing life-threatening infection, especially infections acquired in the ICU. Infections caused by *Streptococcus pneumoniae*, highly resistant to penicillin; *Staphylococcus aureus* and coagulase-negative staphylococci resistant to methicillin and all other beta-lactams; enterococci resistant to vancomycin, ampicillin or both; Enterobacteriaceae and *Pseudomonas aeruginosa* resistant to third-generation cephalosporins and other extended-spectrum beta-lactams; *Clostridium difficile* and *Candida* species are now being encountered by intensive care specialists on a daily basis worldwide, a consequence of the very heavy use of antibiotics in clinical practice, particularly within ICUs.

Fortunately, major advances have been made in our understanding of patterns of infection in critically ill patients, and how to diagnose these infections reasonably expeditiously and accurately. Potent antimicrobial agents are now available to treat every type of bacterial, rickettsial or chlamydial infection, nearly all fungal infections, most parasitic infections, and a growing number of viral infections, especially those caused by herpes viruses – herpes simplex virus, varicella zoster virus, and cytomegalovirus. Moreover, we have begun to achieve a far better understanding of the most effective ways to use antimicrobial agents in terms of dosing schedules, and how to modulate the inflammatory response to life-threatening infection sufficiently to reduce morbidity and mortality.

Finally, perhaps most importantly, the epidemiology of infections acquired in the ICU is now sufficiently well understood that preventive measures, designed to block infection by micro-organisms acquired from the ICU environment as well as from the patient's own microflora, can prevent many life-threatening nosocomial infections. However, the application of this knowledge in ICUs around the world remains inconsistent.

The first two papers selected for this chapter focus on the magnitude of the problem with nosocomial infection and, especially, antibiotic resistance within US ICUs, and the consequences of antibiotic resistance in terms of outcome. Paper 3 reviews the new discipline of pharmacodynamics in antimicrobial therapy, and its importance in clinical practice. Paper 4 examines a novel and promising approach to improving antibiotic use in clinical practice, especially within ICUs: computer-assisted prescribing. Papers 5 and 6 address the vexing problem of diagnosis of infection in critically ill patients who may have fever or other soft signs of sepsis. They assess how best to identify ventilator-associated pneumonia, and, the promise of a simple blood test, the procalcitonin level, to reliably identify patients with early sepsis who will benefit from empiric antimicrobial therapy, as contrasted with those patients who do not have infection as the cause of fever or a systemic inflammatory response syndrome and do not need antimicrobial therapy. Papers 7 and 8

address advances in the management of the leading neurological infection encountered in the ICU, bacterial meningitis. Paper 9 is a report of a remarkable study that shows that intensified glycaemic control in the ICU can reduce morbidity in a wide variety of areas, including the incidence of nosocomial bloodstream infection, and can even reduce ICU and hospital mortality. The final paper deals with an important advance that may greatly reduce the risk of bloodstream infections caused by intravascular devices.

Title

National Nosocomial Infections Surveillance (NNIS) system report, data summary from January 1992–June 2001, issued August 2001: a report from the NNIS system

Author

(ANON). Division of Healthcare Quality Promotion, National Center for Infectious Disease, Centers for Disease Control and Prevention, Public Health Service, US Department of Health and Human Services, Atlanta, GA, USA

Reference

Am J Infect Control 2001; **29**: 404–421

Abstract

Not available

Summary

In the early 1970s, the Centers for Disease Control (CDC) established a nationwide network of US hospitals to provide surveillance data from their institutions, using standardized definitions for nosocomial infection. In recent years, the focus has been on targeted surveillance, primarily within ICUs and neonatal units, and determining rates of surgical site infection in various types of surgery. Summary data from this program, stratified by type of ICU, are published annually. This report summarizes the results of data for 1994–2001 reported to the CDC by >300 hospitals currently in the NNIS Program. Figure 1 shows the relative frequency of the major types of nosocomial infection encountered in US ICUs, and the microbial profile of these infections. This most recent report delineates resistance trends with the leading nosocomial pathogens (Figure 2): in US ICUs, 87.5% of coagulase-negative staphylococci and 55.3% of nosocomial isolates of *Staphylococcus aureus* are now resistant to methicillin (MRSA); 26.3% of all enterococci show resistance to vancomycin (VRE); 3.4% of *Escherichia coli*, 11% of *Klebsiella pneumoniae*, 26.4% of *Pseudomonas aeruginosa*, and 34.9% of *Enterobacter* species show resistance to third-generation cephalosporins, in most instances because of the production of extended-spectrum beta-lactamases (ESBLs); 18% of *P. aeruginosa* are resistant to imipenem, and 27.3% to fluoroquinolones.

Citation count 115

Related references

1. Richards MJ, Edwards JR, Culver DH, Gaynes RP and the National Nosocomial Surveillance System. Nosocomial infections in combined medical-surgical intensive care units in the United States. *Infect Control Hosp Epidemiol* 2000; **21**: 510–515.
2. Vincent J-L, Bihari DJ, Suter PM *et al*. The prevalence of nosocomial infection in intensive care units in Europe: results of the European prevalence of infection in intensive care (EPIC) study. *JAMA* 1995; **274**: 639–644.
3. Kollet MH, Fraser VJ. Antibiotic resistance in the intensive care unit. *Ann Intern Med* 2001; **134**: 298–314
4. CDC. *Staphylococcus aureus* resistant to vancomycin. *MMWR* 2002; **51**: 565–566.

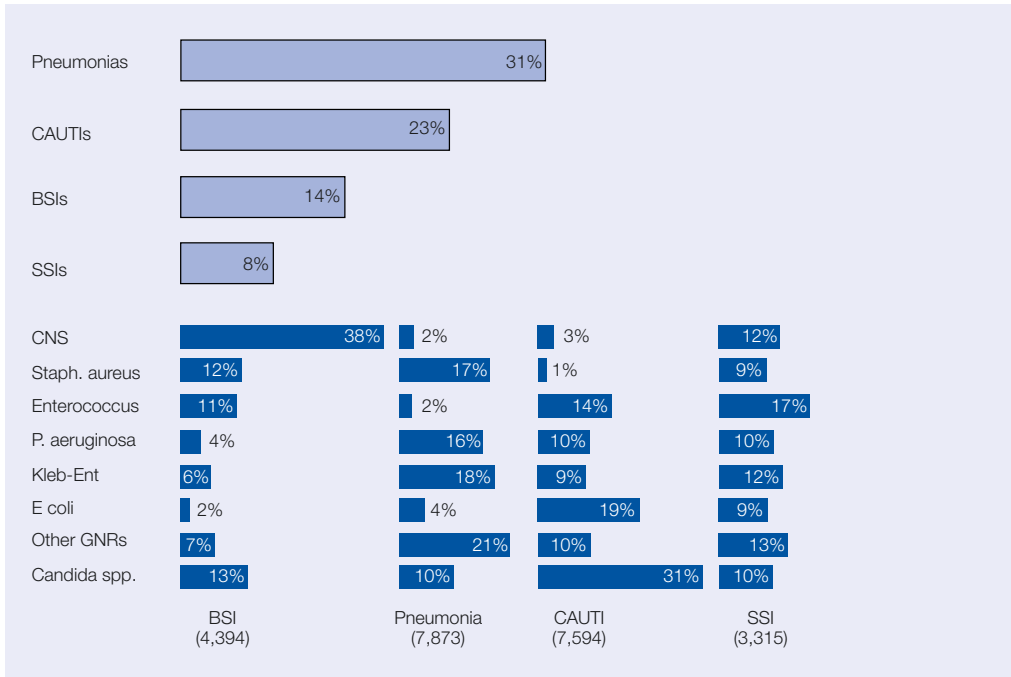

Fig. 13-1. Distribution of 129,041 nosocomial infections occurring in 205 US medical-surgical ICUs during 1992–1998, with microbial profile of ventilator-associated pneumonias, central venous catheter-associated bloodstream infections (BSIs), surgical site infections (SSIs) and catheter-associated urinary tract infections (CAUTIs). CNS, coagulase-negative staphylococci; Kleb-Ent, Klebsiella and Enterobacter spp.; GNR, gram-negative rods (Adapted from Richards MJ, Edwards JR, Culver DH, Gaynes RP. Nosocomial infections in combined medical-surgical intensive care units in the United States. *Infect Control Hosp Epidemiol* 2000; 21: 510–515.)

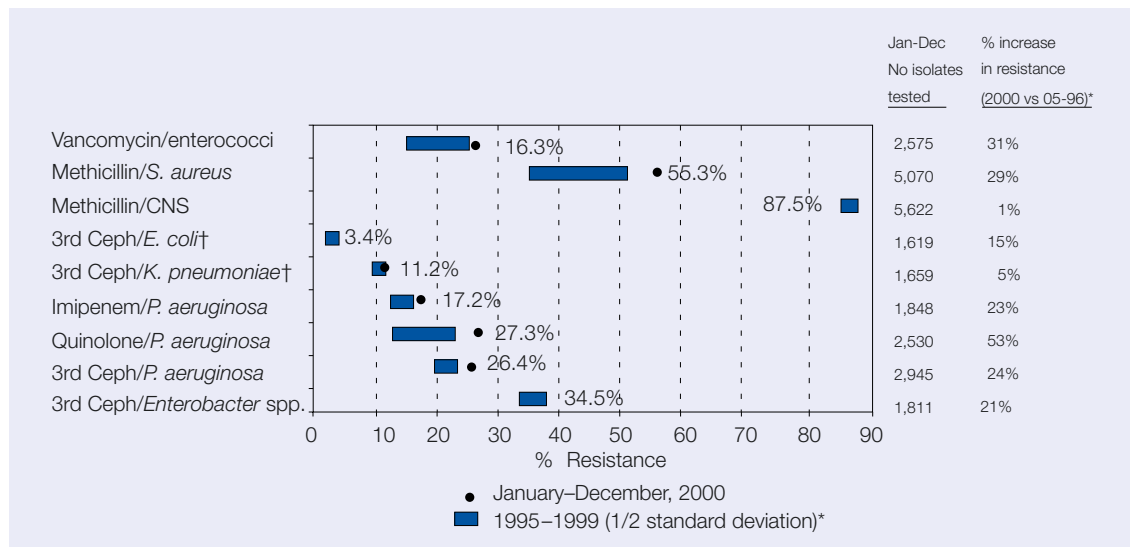

Fig. 13-2. Prevalence of selected antimicrobial-resistant nosocomial pathogens in US intensive care units, with comparison of resistance rates in 1994–1998 and 1999 *Percentage increase in resistance rate between 1994–1998 and 1999. †Resistance of Escherichia coli or Klebsiella pneumoniae reflects non-susceptibility of these organisms to either a third-generation cephalosporin (3rd Ceph) or aztreonam. CNS, coagulase-negative staphylococci. (From Division of Healthcare Quality Promotion, National Center for Infectious Disease, Centers for Disease Control and Prevention, Public Health Service, US Department of Health and Human Services, Atlanta, GA. National Nosocomial Infections (NNIS) System Report, Data Summary from January 1992–June 2001, issued 2001. *Am J Infect Control* 2001; 29: 404–421.)

Key message

The incidence of infection in ICUs is high, but, most notably, rates of resistance are very high and are rising.

Why it's important

The first step in dealing with a problem is to identify and quantify the problem.

Strengths

This paper and numerous companion papers from the NNIS program provide the best measure of the US problem with institutionally acquired infection, especially antimicrobial resistance within US ICUs. All of the participating NNIS hospitals utilize CDC definitions for nosocomial infection, and their laboratories follow recommended methods and criteria for susceptibility testing.

Weaknesses

The CDC's surveillance definitions for central venous catheter-associated bloodstream infection (BSI), and for ventilator-associated pneumonia (VAP), are not as rigorous as those used by most investigators carrying out clinical research on these infections. Moreover, because all of the participating hospitals do not submit data from each ICU every month, the data reported represent an estimate – but the best estimate – of trends in nosocomial infection, particularly antimicrobial resistance within US ICUs.

Relevance

Whereas critical care medicine is synonymous with cutting-edge, high-tech medicine, the technology has been associated with a greatly increased risk of nosocomial infection – now in the range of 15–25% of all patients requiring ventilatory support, central venous catheters, and other life support measures for >3–5 days. Most alarmingly, rates of antimicrobial resistance are rising sharply, and what has long been feared has now occurred: nosocomial infection with MRSA exhibiting high-level resistance (MIC >128 µg/ml) to vancomycin (VMRSA) has been confirmed in Detroit (related reference no. 4). These data emphasize the urgency of greater commitment to nosocomial infection control, especially the application of promising novel technology (e.g. devices engineered to reduce risk of infection), and far more intensive programmes to improve the use of antimicrobial agents within ICUs.

Title

The influence of inadequate antimicrobial treatment of bloodstream infections on patient outcomes in the ICU setting

Author

Ibrahim EH, Sherman G, Ward S, Frazier VJ, Kollef MH

Reference

Chest 2000; **118**: 146–155

Abstract

STUDY OBJECTIVE: To evaluate the relationship between the adequacy of antimicrobial treatment for bloodstream infections and clinical outcomes among patients requiring ICU admission. DESIGN: Prospective cohort study. SETTING: A medical ICU (19 beds) and a surgical ICU (18 beds) from a university-affiliated urban teaching hospital. PATIENTS: Between July 1997 and July 1999, 492 patients were prospectively evaluated. INTERVENTION: Prospective patient surveillance and data collection. RESULTS: One hundred forty-seven patients (29.9%) received inadequate antimicrobial treatment for their bloodstream infections. The hospital mortality rate of patients with a bloodstream infection receiving inadequate antimicrobial treatment (61.9%) was statistically greater than the hospital mortality rate of patients with a bloodstream infection who received adequate antimicrobial treatment (28.4%; relative risk, 2.18; 95% confidence interval [CI], 1.77 to 2.69; $p < 0.001$). Multiple logistic regression analysis identified the administration of inadequate antimicrobial treatment as an independent determinant of hospital mortality (adjusted odds ratio [AOR], 6.86; 95% CI, 5.09 to 9.24; $p < 0.001$). The most commonly identified bloodstream pathogens and their associated rates of inadequate antimicrobial treatment included vancomycin-resistant enterococci ($n = 17$; 100%), *Candida* species ($n = 41$; 95.1%), oxacillin-resistant *Staphylococcus aureus* ($n = 46$; 32.6%), coagulase-negative staphylococci ($n = 96$; 21.9%), and *Pseudomonas aeruginosa* ($n = 22$; 10.0%). A statistically significant relationship was found between the rates of inadequate antimicrobial treatment for individual microorganisms and their associated rates of hospital mortality (Spearman correlation coefficient = 0.8287; $p = 0.006$). Multiple logistic regression analysis also demonstrated that a bloodstream infection attributed to *Candida* species (AOR, 51.86; 95% CI, 24.57 to 109.49; $p < 0.001$), prior administration of antibiotics during the same hospitalization (AOR, 2.08; 95% CI, 1.58 to 2.74; $p = 0.008$), decreasing serum albumin concentrations (1-g/dL decrements) (AOR, 1.37; 95% CI, 1.21 to 1.56; $p = 0.014$), and increasing central catheter duration (1-day increments) (AOR, 1.03; 95% CI, 1.02 to 1.04; $p = 0.008$) were independently associated with the administration of inadequate antimicrobial treatment. CONCLUSIONS: The administration of inadequate antimicrobial treatment to critically ill patients with bloodstream infections is associated with a greater hospital mortality compared with adequate antimicrobial treatment of bloodstream infections. These data suggest that clinical efforts should be aimed at reducing the administration of inadequate antimicrobial treatment to hospitalized patients with bloodstream infections, especially individuals infected with antibiotic-resistant bacteria and *Candida* species.

Summary

Over the past 40 years, a number of studies have examined the relationship between the adequacy of antimicrobial treatment of bloodstream infections (BSIs) and clinical outcome.

However, most of these studies were retrospective, and few made any effort to adjust for severity of illness, site of infection, and other factors that influence outcome. In this study, 492 patients hospitalized in a medical and a surgical ICU at Washington University School of Medicine-Barnes-Jewish Hospital in St Louis, MO, USA between July 1997 and July 1999, were studied prospectively. 'Inadequate' antimicrobial therapy was defined by the initial antimicrobial regimen given until the results of blood cultures and susceptibilities were known, and included the lack of agents effective against the specific class of infecting micro-organisms (e.g. the absence of an antifungal agent for candidemia), or the use of drugs to which the blood culture isolate or isolates were resistant (e.g. use of oxacillin or other beta-lactams for MRSA bacteremia). Data on other important co-variables – age, sex, severity of illness (APACHE II score), heart failure, underlying malignancy, HIV infection, the need for surgical intervention, hemodialysis, or vasopressors – were collected prospectively. The influence of each factor on outcome was evaluated with multivariable statistical models. Astonishingly, 147 patients (29.9%) received inadequate antimicrobial therapy for their bloodstream infection, which translated to a crude mortality of 61.9%, as compared with a mortality of 28.4% in patients who received adequate antimicrobial therapy (crude relative risk, 2.18; $p < 0.001$). Stepwise logistic regression analysis showed that inadequate antimicrobial therapy was a powerful independent predictor of hospital mortality (adjusted odds ratio, 6.0; $p < 0.001$).

Citation count 366

Related references

1. Weinstein MP, Pounds ML, Quartey SM *et al*. The clinical significance of positive blood cultures in the 1990s: a prospective, comprehensive evaluation of the microbiology, epidemiology and outcome of bacteremia and fungemia in adults. *Clin Infect Dis* 1997; **24**: 584–602.
2. Leibovici L, Shraga I, Drucker M *et al*. The benefit of appropriate empirical antibiotic treatment in patients with bloodstream infection. *J Intern Med* 1998; **244**: 379–386.
3. Feikin DR, Schuchat A, Kolczak M *et al*. Mortality from invasive pneumococcal pneumonia in the era of antibiotic resistance, 1995–1997. *Am J Public Health* 2000; **90**: 223–229.
4. Safdar N, Maki DG. The commonality of risk factors for nosocomial colonization and infection with antimicrobial-resistant *Staphylococcus aureus*, enterococcus, gram-negative bacilli, *Clostridium difficile*, and *Candida*. *Ann Intern Med* 2002; **136**: 834–844.

Key message

In one of the leading academic medical centers in the world, nearly one-third of ICU patients with a community-acquired or nosocomial BSI received inadequate antimicrobial therapy, primarily because it was not appreciated that the patient had major risk factors for colonization or infection by resistant organisms. This is probably occurring on a wide scale worldwide, and clinicians need to be able to identify patients at risk for infection with resistant organisms.

Why it's important

This paper clearly identifies a major correctable flaw in the therapeutic approach to infection in the ICU. Once again, identification of the problem is key to managing it more effectively.

Strengths

This was a prospective study which carefully evaluated all potential clinical variables that might influence the outcome of treatment of a BSI, and was sufficiently large to allow robust statistical analyses supporting the conclusions drawn.

Weaknesses

This was a single-center study. Had it had been a similar study with standardized methods and study design in multiple centers, it would have had greater applicability.

Relevance

As pointed out, there has been a marked increase in both nosocomial and community-acquired infections caused by MRSA, VRE/VAREC, ESBL-positive gram-negative bacilli, *C. difficile*, and *Candida* species in ICUs worldwide. Community-acquired MRSA is beginning to be seen in many areas of the USA. Patients likely to be infected by multi-resistant pathogens almost always have characteristic risk factors: significant underlying diseases, especially cancer or organ transplantation; recent surgery; nosocomial sepsis, in most cases, device-related, especially BSIs related to central venous catheters; and almost universally, *history of prior antimicrobial therapy*, especially with cephalosporins or other broad-spectrum antibiotics (see related reference no. 4). With such patients who are septic, intensive care clinicians must recognize the high risk of infection with multi-resistant organisms. If a hospitalized patient has received intensive antimicrobial therapy and is known to be colonized by candida (especially in the urinary tract or a surgical wound), or a CVC tip culture returns positive, empiric therapy with fluconazole or amphotericin B is justified.

Title

Pharmacokinetic/pharmacodynamic parameters: rationale for antibacterial dosing of mice and men

Author

Craig WA

Reference

Clin Infect Dis 1998; **26**: 1–12

Abstract

Investigations over the past 20 years have demonstrated that antibacterials can vary markedly in the time course of antimicrobial activity. These differences in pharmacodynamic activity have implications for optimal dosage regimens. The results of more recent studies suggest that the magnitude of the pharmacokinetic/pharmacodynamic parameters required for efficacy are relatively similar in animal infection models and in human infections. However, there is still much to learn. Additional studies are needed to further correlate pharmacokinetic/pharmacodynamic parameters for many antibacterials with therapeutic efficacy in a variety of animal infection models, and in human infections. The potential value of using pharmacokinetic/pharmacodynamic parameters as guides for establishing optimal dosing regimens for new and old drugs, and for new emerging pathogens and resistant organisms, for setting susceptibility breakpoints, and for reducing the cost of drug development should make the continuing search for the therapeutic rationale of antibacterial dosing of mice and men worthwhile.

Summary

The pharmacology of antimicrobial therapy can be divided into distinct components (Figure): pharmacokinetics, the absorption, distribution, and elimination of the drug; and pharmacodynamics, the relationship between the time course of drug concentrations in serum and at the site of infection, and the rate of microbial killing. Antimicrobial therapy is the sum of the inter-relationship between pharmacokinetics and pharmacodynamics. In this review by the founder of the field of pharmacodynamics, Craig reviews the animal studies and clinical trials that illustrate important differences in the pharmacodynamic characteristics of the different classes of antimicrobial agents, and shows that application of pharmacokinetics and pharmacodynamics in determining dosing regimens has a significant impact on the outcome of infection. In general, gram-negative bacilli, aminoglycosides, and fluoroquinolones exhibit concentration-dependent killing and have a prolonged post-antibiotic effect, which is why the peak blood level and the peak level/minimal inhibitory concentration (MIC) are the best predictors of outcome. These studies have been applied to show that once-daily dosing with gentamicin and other aminoglycosides assures maximal therapeutic levels for treatment of life-threatening gram-negative infections, and is associated with a lower incidence of toxicity. In contrast, beta-lactam antibiotics (especially with gram-positive cocci), and glycopeptides (such as vancomycin), tetracyclines, macrolides, clindamycin, and quinupristin-dalfopristin do not exhibit concentration-dependent killing and have a negligible post-antibiotic effect. Thus, time-above-MIC is the pharmacodynamic parameter that has the best correlation with therapeutic efficacy. A growing number of clinical trials have shown that dosing schedules based on these principles translate to improved outcomes, compared with the results of empiric dosing schedules without a pharmacokinetic/pharmacodynamic underpinning.

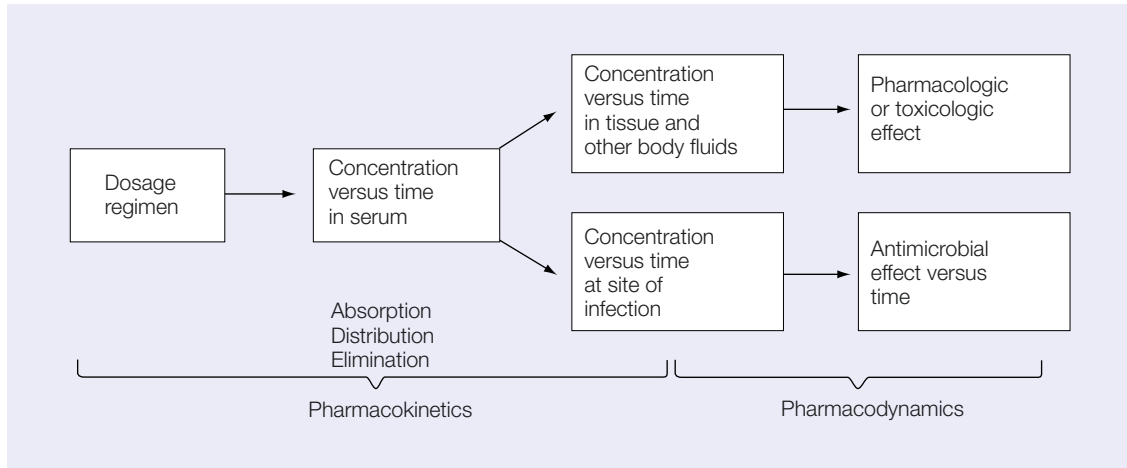

Fig. 13-3. Overview of pharmacokinetics and pharmacodynamics in antimicrobial chemotherapy (Adapted from Craig WA. Pharmacokinetics/pharmacodynamic parameters: the rationale for antibacterial dosing of mice and men. *Clin Infect Dis* 1998; 26: 1–12.)

Citation count 770

Related references

1. Drusano GL. Human pharmacodynamics of beta-lactams, aminoglycosides and the combination. *Scand J Infect Dis* 1991; **74** (Suppl): 235–248.
2. Moore RD, Lietman PS, Smith CR. Clinical response to aminoglycoside therapy: importance of the ratio of peak concentration to minimal inhibitory concentration. *J Infect Dis* 1987; **155**: 93–99.
3. Prins JM, Buller HR, Kuijper EJ, Tange RA, Speelman P. Once versus thrice daily gentamicin in patients with serious infections. *Lancet* 1993; **341**: 335–339.
4. Forrest A, Nix DE, Ballow CH, Goss TF, Birmingham MC, Schentag JJ. Pharmacodynamics of intravenous ciprofloxacin in seriously ill patients. *Antimicrob Agents Chemother* 1993; **37**: 1073–1081.
5. Ambrose PG, Grasela DM, Grasela TH, Passarell J, Mayer HB, Pierce PF. Pharmacodynamics of fluoroquinolones against *Streptococcus pneumoniae* in patients with community-acquired respiratory tract infections. *Antimicrob Agents Chemother* 2001; **45**: 2793–2797.

Key message

These animal and clinical studies show that it is not sufficient for clinicians to simply understand the pharmacokinetics of an antimicrobial agent, but that it is also essential to understand the pharmacodynamics of the drug, the basis for current recommended dosing schedules, especially when treating life-threatening infections such as bacteremia or gram-negative bacillary pneumonia.

Why it's important

Fundamental to effective therapeutic intervention is not only a reasonable understanding of the mechanisms by which the drugs work, but also logical application of that knowledge.

Strengths

This review is elegant in its insights, and the large number of top-flight experimental studies reviewed which underlie the principles expounded.

Weaknesses

Whereas a growing number of clinical trials have confirmed the findings of pharmacodynamic animal studies, the best data are still based on studies in animal models of infection, particularly with mice. These findings in animal models need to be confirmed *clinically* with *all* antimicrobial agents, including antifungal and antiviral agents.

Relevance

It is essential that intensive care clinicians become cognizant of the importance of pharmacodynamics, as well as pharmacokinetics, in using antimicrobial agents in clinical practice, and that dosing schedules based on pharmacodynamic principles come into consistent use.

Title

A computer-assisted management program for antibiotics and other antiinfective agents

Author

Evans RS, Pestotnik SL, Classen DC, Clemmer TP, Weaver LK, Orme JF Jr, Lloyd JF, Burke JP

Reference

N Engl J Med 1998; **338**: 232–238

Abstract

BACKGROUND AND METHODS: Optimal decisions about the use of antibiotics and other antiinfective agents in critically ill patients require access to a large amount of complex information. We have developed a computerized decision-support program linked to computer-based patient records that can assist physicians in the use of antiinfective agents and improve the quality of care. This program presents epidemiologic information, along with detailed recommendations and warnings. The program recommends antiinfective regimens and courses of therapy for particular patients, and provides immediate feedback. We prospectively studied the use of the computerized antiinfectives-management program for one year in a 12-bed intensive care unit. **RESULTS:** During the intervention period, all 545 patients admitted were cared for with the aid of the antiinfectives-management program. Measures of processes and outcomes were compared with those for the 1136 patients admitted to the same unit during the two years before the intervention period. The use of the program led to significant reductions in orders for drugs to which the patients had reported allergies (35, vs. 146 during the preintervention period; $p < 0.01$), excess drug dosages (87 vs. 405, $p < 0.01$), and antibiotic-susceptibility mismatches (12 vs. 206, $p < 0.01$). There were also marked reductions in the mean number of days of excessive drug dosage (2.7 vs. 5.9, $p < 0.002$), and in adverse events caused by antiinfective agents (4 vs. 28, $p < 0.02$). In analyses of patients who received antiinfective agents, those treated during the intervention period who always received the regimens recommended by the computer program ($n = 203$) had significant reductions, as compared with those who did not always receive the recommended regimens ($n = 195$), and those in the preintervention cohort ($n = 766$), in the cost of antiinfective agents (adjusted mean, \$102 vs. \$427 and \$340, respectively; $p < 0.001$), in total hospital costs (adjusted mean, \$26,315 vs. \$44,865 and \$35,283; $p < 0.001$), and in the length of the hospital stay days (adjusted mean, 10.0 vs. 16.7 and 12.9; $p < 0.001$).

CONCLUSIONS: A computerized antiinfectives-management program can improve the quality of patient care and reduce costs.

Summary

The field of antimicrobial therapy has become increasingly complex, with a myriad of human pathogens – including hundreds of species of increasingly resistant bacteria, as well as numerous fungi, rickettsia, chlamydia, mycoplasmas, and viruses – and >100 systemic antimicrobial drugs now available in the USA alone. It becomes a daunting challenge for the intensive care clinician to select the best antimicrobial regimen, and to use the best dosing schedule, based on the patient's presumed infection, unique physiology, and capacity to excrete the drug or drugs. Studies have shown that, in general, up to 50% of antimicrobial

regimens are suboptimal for the targeted clinical application. To try to improve the use of antibiotics and other antimicrobial agents in critically ill patients, Burke's group at the Latter Day Saints Hospital-University of Utah Medical Center has developed a computerized decision-support programme linked to computer-based patient records that can assist physicians in the use of antimicrobial agents. The programme presents epidemiological information, along with detailed recommendations and warnings, and recommends a specific regimen tailored for each patient, providing immediate feedback. In this paper, the authors report the impact of this novel programme over 1 year in a 12-bed medical-surgical ICU. Outcome parameters in 1136 patients during a baseline period before the programme was introduced and in 545 patients admitted and cared for with the aid of the programme are presented. Computer-assisted prescribing led to significant reductions in orders for drugs to which patients had reported allergies (35 vs 146, $p < 0.01$), excessive drug dosages (87 vs 405, $p < 0.1$), and inadequate therapy (12 vs 206, $p < 0.01$), and there were marked reductions in the mean number of days of excessive drug dosage (2.7 vs 5.9, $p < 0.002$), and in serious adverse events caused by antimicrobial infective agents (4 vs 28, $p < 0.02$). Most impressively, the costs of antimicrobial therapy (adjusted mean, \$102 vs \$427, $p < 0.001$), overall hospital costs (\$26,315 vs \$44,865, $p < 0.001$), and length of hospital stay (10.0 vs 16.7 days, $p < 0.001$) were greatly reduced.

Citation count 435

Related references

1. Pestotnik SL, Classen DC, Evans RS, Burke JP. Implementing antibiotic practice guidelines through computer-assisted decision support: clinical and financial outcomes. *Ann Intern Med* 1996; **124**: 884–890.
2. Burke JP, Pestotnik SL. Antibiotic use and microbial resistance in intensive care units: impact of computer-assisted decision support. *J Chemother* 1999; **11**: 530–535.
3. Evans RS, Pestotnik SL, Classen DC, Burke JP. Evaluation of a computer-assisted antibiotic-dose monitor. *Ann Pharmacother* 1999; **33**: 1026–1031.

Key message

A computer-assisted decision-support programme markedly improved use of antimicrobial agents in a medical-surgical ICU, and was shown to significantly improve patient outcomes and reduce costs.

Why it's important

In an era where computer capabilities are advancing rapidly, there are potential means of using them to significantly enhance clinical performance. This paper and this work clearly illustrate how effective this can be.

Strengths

The authors rigorously evaluated the effectiveness of their novel computer-assisted decision-support programme, addressing relevant and clear-cut outcome variables.

Weaknesses

The study relies on historical controls and was done in only a single center, which developed the programme. It is essential to determine whether the programme is sufficiently user-friendly and powerful that it can be used with comparable efficacy in other centers.

Relevance

It seems clear that, at least in the investigators' center, this novel approach to improving the use of antimicrobial agents in an ICU is highly effective and translates to significantly improved outcomes. In related papers (cited above), in a much larger, general hospital population, the authors have shown a significant reduction in antimicrobial use, a three-fold reduction in adverse drug reactions, and a two-fold reduction in nephrotoxicity. Moreover, they have shown that antimicrobial resistance rates have been stable or declining, and hospital mortality has decreased, from 3.65% in 1988 to 2.65% in 1994. Computer-assisted decision-support programmes that provide local clinician-derived practice guidelines can improve antibiotic use, reduce costs, and stabilize the emergence of antibiotic-resistant pathogens. This novel programme is scheduled to become commercially available in the near future.

Title

Invasive and noninvasive strategies for management of suspected ventilator-associated pneumonia: a randomized trial

Author

Fagon J-Y, Chastre J, Wolff M, Gervais C, Parer-Aubas S, Stéphan F, Similowski T, Mercat A, Diehl J-L, Sollet J-P, Tenaillon A, for the VAP Trial Group

Reference

Ann Intern Med 2000; **132**: 621–630

Abstract

BACKGROUND: Optimal management of patients who are clinically suspected of having ventilator-associated pneumonia remains open to debate. **OBJECTIVE:** To evaluate the effect on clinical outcome and antibiotic use of two strategies to diagnose ventilator-associated pneumonia, and select initial treatment for this condition. **DESIGN:** Multicenter, randomized, uncontrolled trial. **SETTING:** 31 intensive care units in France. **PATIENTS:** 413 patients suspected of having ventilator-associated pneumonia. **INTERVENTION:** The invasive management strategy was based on direct examination of bronchoscopic protected specimen brush samples or bronchoalveolar lavage samples and their quantitative cultures. The noninvasive (“clinical”) management strategy was based on clinical criteria, isolation of microorganisms by nonquantitative analysis of endotracheal aspirates, and clinical practice guidelines. **MEASUREMENTS:** Death from any cause, quantification of organ failure, and antibiotic use at 14 and 28 days. **RESULTS:** Compared with patients who received clinical management, patients who received invasive management had reduced mortality at day 14 (16.2% and 25.8%; difference, –9.6 percentage points [95% CI, –17.4 to –1.8 percentage points]; $p = 0.022$), decreased mean Sepsis-related Organ Failure Assessment scores at day 3 (6.1+/-4.0 and 7.0+/-4.3; $p = 0.033$), and day 7 (4.9+/-4.0 and 5.8+/-4.4; $p = 0.043$), and decreased antibiotic use (mean number of antibiotic-free days, 5.0+/-5.1 and 2.2+/-3.5; $p < 0.001$). At 28 days, the invasive management group had significantly more antibiotic-free days (11.5+/-9.0 compared with 7.5+/-7.6; $p < 0.001$), and only multivariate analysis showed a significant difference in mortality (hazard ratio, 1.54 [CI, 1.10 to 2.16]; $p = 0.01$). **CONCLUSIONS:** Compared with a noninvasive management strategy, an invasive management strategy was significantly associated with fewer deaths at 14 days, earlier attenuation of organ dysfunction, and less antibiotic use in patients suspected of having ventilator-associated pneumonia.

Summary

Ventilator-associated pneumonia (VAP) is the most commonly identified life-threatening infection in the ICU, and causes major morbidity and mortality. Diagnosing VAP in patients who usually have abnormal chest radiographs on entry into the ICU, and who more often than not show lower respiratory tract colonization by nosocomial organisms has been one of the major diagnostic challenges in critical care practice, and the subject of much debate. It is widely accepted that many ventilated patients who do not have VAP receive unneeded antimicrobial therapy for presumed VAP, exposing them to toxicity, increasing hospital costs, and promoting emergence of resistant micro-organisms. Moreover, failure of conventional diagnostic methods (clinical criteria, radiographic changes, standard non-quantitative cultures of tracheal secretions) delays essential treatment of life-threatening MRSA or gram-negative

nosocomial VAP. In this multi-center randomized trial in 31 French ICUs, 413 ventilated patients suspected of having VAP were randomized to have direct examination and quantitative cultures of bronchoscopic protected brush specimens or broncho-alveolar lavage (BAL) samples (invasive strategy), or the use of clinical criteria with Gram's stain and qualitative culture of an endotracheal aspirate (non-invasive strategy, control group). Patients in the invasive diagnostic group had a decreased mean sepsis-related organ-failure assessment score on day 3 (6.1 vs 7.0, $p = 0.03$) and day 7 (4.9 vs 5.8, $p = 0.03$) – but not at day 28 – and had significantly more antibiotic-free days (11.5 vs 7.5, $p < 0.001$). Moreover, they were less likely to become colonized by *Candida* species (22.5% vs 11.3%, $p = 0.0025$). However, there were no significant differences in duration of ICU stay, mechanical ventilation-free days, or colonization by resistant nosocomial bacteria during ventilatory support. Although the initial regimen proved inadequate in 11.5% of patients in the non-invasive diagnostic control group, and only 0.5% of the invasive diagnostic group ($p < 0.01$), mortality difference in the two groups at 28 days was not significant in a univariate analysis. However, in a multivariable analysis, the invasive diagnostic strategy was associated with a significant reduction in mortality (hazard ratio, 0.58; $p = 0.039$).

Citation count 238

Related references

1. Sterling TR, Ho EJ, Brehm WT, Kirkpatrick MB. Diagnosis and treatment of ventilator-associated pneumonia – impact on survival. A decision analysis. *Chest* 1996; **110**: 1025–1034.
2. Luna CM, Vujacich P, Niederman MS *et al*. Impact of BAL data on the therapy and outcome of ventilator-associated pneumonia. *Chest* 1997; **111**: 676–685.
3. Bonten MJ, Bergmans DC, Stobberingh EE *et al*. Implementation of bronchoscopic techniques in the diagnosis of ventilator-associated pneumonia to reduce antibiotic use. *Am J Respir Crit Care Med* 1997; **156**: 1820–1824.
4. Heyland DK, Cook DJ, Marshall J *et al*. The clinical utility of invasive diagnostic techniques in the setting of ventilator-associated pneumonia. Canadian Critical Care Trials Group. *Chest* 1999; **115**: 1076–1084.
5. Papazian L, Thomas P, Garbe L *et al*. Bronchoscopic or blind sampling techniques for the diagnosis of ventilator-associated pneumonia. *Am J Respir Crit Care Med* 1995; **152**: 1982–1991.
6. Marquette CH, Georges H, Wallet F *et al*. Diagnostic efficiency of endotracheal aspirates with quantitative bacterial cultures in intubated patients with suspected pneumonia. Comparison with the protected specimen brush. *Am Rev Respir Dis* 1993; **148**: 138–144.
7. Mayhall CG. Ventilator-associated pneumonia or not? Contemporary diagnosis. *Emerg Infect Dis* 2001; **7**: 200–204.

Key message

Compared with conventional, non-invasive diagnostic studies, an invasive strategy utilizing bronchoscopy with quantitative culture of a protected brush specimen or BAL was associated with significantly earlier attenuation of organ dysfunction, less antibiotic use, and reduced nosocomial colonization by *Candida* species.

Why it's important

Accurate diagnosis of ventilator-associated pneumonia and, in particular, differentiation between colonization and infection, is a difficult issue. This paper does not resolve the issue, but does provide some guidance for management as well as direction for further study.

Strengths

This was a large, prospective multi-center trial with a standardized approach to treatment based on the results of diagnostic studies, which focused on withholding antibiotics if Gram's staining of the bronchoscopic specimen was negative; the use of antibiotics with narrow-spectrum activity for pathogens cultured bronchoscopically, and for discontinuation of therapy when quantitative cultures were not consistent with infection (brush sample 10^3 colony forming units (CFU) or BAL $\leq 10^4$ CFU).

Weaknesses

A major weakness of the study was the unblinded study design. Moreover, a modest number of patients was studied in each institution (approximately 14 per center on average), and thus, given the broad microbial profile and antibiotic susceptibilities of infecting organisms in VAP, it is unlikely that any single center had adequate representation of the full potential microbial profile of VAP. Two different diagnostic bronchoscopic techniques were used in the invasive strategy group (protected specimen brush and BAL), and in the control group, qualitative rather than quantitative cultures of endotracheal aspirates were done, despite growing evidence that quantitative cultures enhance the diagnostic utility of cultures of endotracheal aspirates. The protocol for modification of the antimicrobial regimen when culture results and susceptibility became available does not appear to have been the same in the two groups. Finally, no cost or cost-effectiveness data were provided.

Relevance

Prior studies of the most reliable way to diagnose VAP, comparing standard non-invasive strategies vis-a-vis culture and Gram's stain of endotracheal aspirates, with quantitative cultures of bronchoscopically acquired specimens, have yielded less conclusive or negative results. This large multi-center trial suggests, titillatingly, that bronchoscopy should now be considered the standard for intubated and mechanically ventilated patients who show signs of sepsis or other clinical findings that could represent early VAP. However, given the lack of impact of the invasive diagnostic strategies on length of ICU stay or duration of mechanical ventilatory support, and the marginal difference in mortality in the two groups, the authors do not provide adequate cost-effectiveness data to indicate that intensive care clinicians should use bronchoscopy routinely for evaluation of patients with suspected VAP. Moreover, there is a growing body of research suggesting that simpler and far less expensive techniques, such as quantitative cultures of endotracheal aspirates or the use of blind endotracheal BAL (mini-BAL), can provide diagnostic results comparable to bronchoscopic techniques.

Title

Calcitonin precursors are reliable markers of sepsis in a medical intensive care unit

Author

Muller B, Becker KL, Schächinger H, Rickenbacher PR, Huber PR, Zimmerli W, Ritz R

Reference

Crit Care Med 2000; **28**: 977–983

Abstract

OBJECTIVE: The diagnosis of infection in critically ill patients is challenging because traditional markers of infection are often misleading. For example, serum concentrations of calcitonin precursors are increased in patients with infections. However, their predictive accuracy for the diagnosis of sepsis in unselected patients in a medical intensive care unit (ICU) is unknown. Therefore, we compared the usefulness of serum concentrations of calcitonin precursors, C-reactive protein, interleukin-6, and lactate for the diagnosis of sepsis in consecutive patients suffering from a broad range of diseases with an anticipated stay of ≥ 24 hours in a medical ICU. **DESIGN:** Prospective cohort study. **SETTING:** Medical intensive care unit in a university medical center. **PATIENTS:** 101 consecutive critically ill patients. **INTERVENTION:** None. **MEASUREMENTS AND MAIN RESULTS:** Blood samples were collected at various time points during the course of the disease. Systemic inflammatory response syndrome, sepsis, severe sepsis, and septic shock were diagnosed according to standardized criteria, and patients were reclassified daily without prior knowledge of the serum concentrations of calcitonin precursors or interleukin-6. At admission, 99% of the patients had systemic inflammatory response syndrome, 53% had sepsis, and 5% developed sepsis during their stay in the ICU. Calcitonin precursors, C-reactive protein, interleukin-6, and lactate levels increased with the severity of infection ($p < 0.01$, one-way analysis of variance). In a receiver operating characteristic curve analysis, calcitonin precursors were found to be the most reliable laboratory variable for the diagnosis of sepsis, as compared with C-reactive protein, interleukin-6, and lactate ($p < 0.01$, for each comparison). Calcitonin precursor concentrations of >1 ng/mL had sensitivity of 89% and specificity of 94% for the diagnosis of sepsis. High serum concentrations of calcitonin precursors were associated with poor prognosis ($p = 0.01$). **CONCLUSIONS:** In a medical ICU, serum calcitonin precursor concentrations are more sensitive and are specific markers of sepsis as compared with serum C-reactive protein, interleukin-6, and lactate levels.

Summary

Many patients with critical illness in the ICU show fever and other signs of the systemic inflammatory response syndrome (SIRS) unrelated to infection. Conversely, many patients (particularly the elderly or compromised), do not exhibit characteristic features of local or systemic infection on examination. Thus, accurate and early diagnosis of infection in critically ill ICU patients remains a challenge. Conventional laboratory tests, such as white blood cell count, erythrocyte sedimentation rate, or C-reactive protein, are not specific and often prove misleading. Unnecessary empiric antimicrobial therapy in uninfected patients contributes to the emergence of antibiotic resistance. Blood levels of procalcitonin (PCT), the prohormone of calcitonin, are generally at or below the limit of detection in healthy

subjects. In 1993, it was serendipitously found that patients with bacterial infection, particularly sepsis, show markedly elevated levels of PCT. The production of PCT during inflammation has been linked with bacterial endotoxin and high levels of inflammatory cytokines. In this study in a medical ICU in a university hospital, 100 consecutive critically ill patients – 99% of whom showed features of SIRS – had levels of PCT, interleukin-6, C-reactive protein, and lactate measured prospectively for utility in diagnosis of bacterial or fungal infection, sepsis, septic shock, and conditions other than infection as the cause of the patient's symptoms. Infection was diagnosed microbiologically in 58% of the patients at some time during their ICU course. In this study, it was found that a PCT level >1 mg/ml showed 89% sensitivity, 94% specificity, 90% negative predictive value, and 94% positive predictive value for diagnosis of sepsis. Uninfected patients, with or without SIRS, generally showed very low levels, whereas patients with severe sepsis and septic shock showed greatly increased levels (Figure), providing excellent discrimination between absence of infection and early infection or sepsis. The receiver-operating-characteristic curve for PCT as a measure of diagnostic accuracy was far superior to that for interleukin-6, C-reactive protein, or blood lactate ($p = 0.01$).

Citation count 129

Related references

1. Hatherill M, Tibby SM, Sykes K, Turner C, Murdoch IA. Diagnostic markers of infection: comparison of procalcitonin with C-reactive protein and leukocyte count. *Arch Dis Child* 1999; **81**: 417–421.

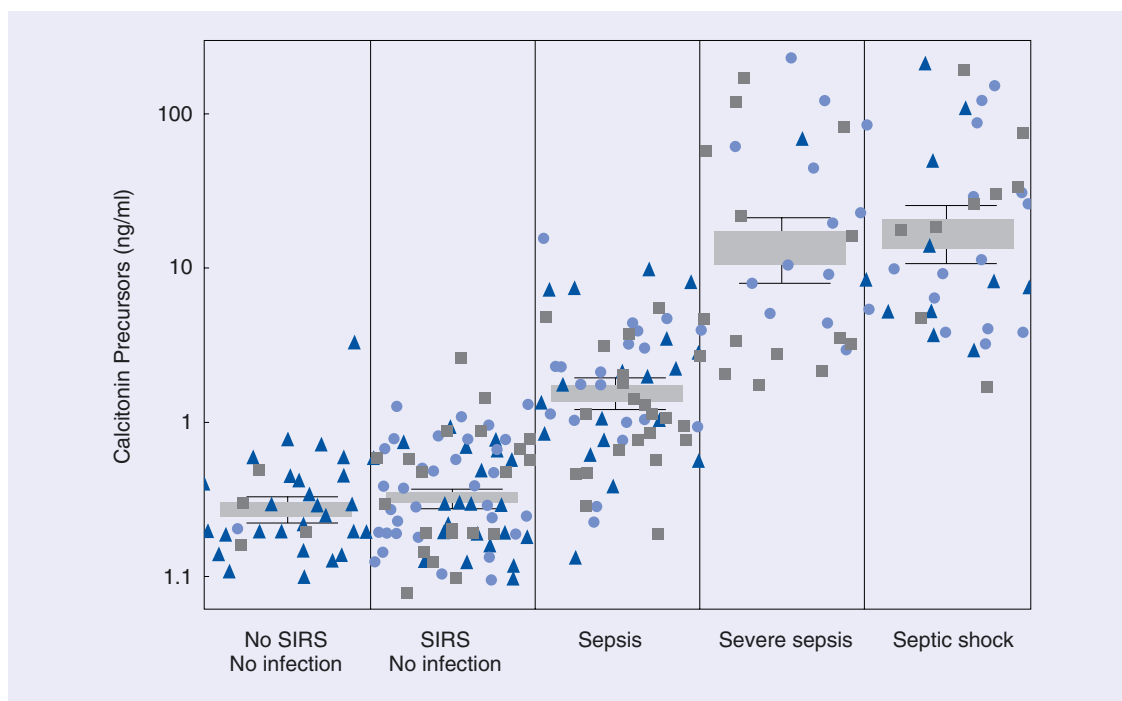

Fig. 13-4. Serum calcitonin precursor levels in critically ill patients in a medical ICU: ●, day of admission; ■, day 2; ▲, day of discharge or death. SIRS, systemic inflammatory response syndrome (From Muller B, Becker KL, Schachinger H, Rickenbacher PR, Huber PR, Zimmerli W, Ritz R. Calcitonin precursors are reliable markers of sepsis in a medical intensive care unit. *Crit Care Med* 2000; **28**: 977–983.)

2. Brunkhorst FM, Eberhard OK, Brunkhorst R. Discrimination of infectious and noninfectious causes of early acute respiratory distress syndrome by procalcitonin. *Crit Care Med* 1999; **27**: 2172–2176.
3. Carlet J. Rapid diagnostic methods in the detection of sepsis. *Infect Dis Clin North Am* 1999; **13**: 483–494.

Key message

Procalcitonin levels showed excellent discrimination for diagnosis of infection, particularly early sepsis, as contrasted with SIRS unrelated to infection, in a prospective blinded study in a university hospital medical ICU.

Why it's important

There is a clear need for an early, dependable marker of clinical infection. Procalcitonin is closer to achieving that goal than the current available markers.

Strengths

The study was prospective and the results of PCT levels were not made available to the clinician making the assessment of whether or not the patient actually had infection, sepsis or septic shock, by conventional criteria.

Weaknesses

The conventional criteria used for diagnosis of infection are unclear: the authors simply cite a well-known infectious disease text which gives relatively little specific information on how best to diagnose infection at various sites in the ICU, especially VAP. The investigators do not state whether bronchoscopic methods were used for diagnosing VAP, the most common infection identified in the study. Finally, the study results and conclusions would have been more robust had the study population been larger, and the study overall would have even greater impact had it been a multi-center trial.

Relevance

Intense efforts have been made during the past decade to develop a blood test that would permit rapid and reliable diagnosis of bacterial or fungal infection that warrants therapy, particularly in its earliest stage. White blood cell count, erythrocyte sedimentation rate, C-reactive protein, or cytokine levels all have far too little specificity, and results of standard cultures are often unavailable for 24–48 hours. A considerable literature beyond the studies cited above suggests that blood levels of the precursor molecule for calcitonin, PCT, show excellent sensitivity and specificity for diagnosis of invasive bacterial or fungal infection. Patients with viral infection, and uninfected patients who have had recent cardiopulmonary bypass surgery or with transplant organ rejection, generally do not show elevated PCT levels. Some studies have suggested that PCT may not be as discriminatory in patients who are severely immunocompromised or granulocytopenic. However, these studies generally have shown that PCT levels perform at least as well or better in this population than conventional laboratory methods of diagnosis. It would appear that commercial PCT assays should be approved and made available for ICU practice. PCT levels offer the promise of implementing earlier antimicrobial therapy in patients with serious infection without characteristic diagnostic features, but also, and perhaps most importantly, for withholding unneeded antimicrobial therapy. The test might well prove to be a useful weapon for controlling antimicrobial resistance in the ICU.

Title

Comparative efficacy of ceftriaxone and cefuroxime for treatment of bacterial meningitis

Author

Lebel MH, Hoyt MJ, McCracken GH Jr

Reference

J Pediatr 1989; **114**: 1049–1054

Abstract

To assess the comparative efficacy of cefuroxime and ceftriaxone for the treatment of bacterial meningitis, we reviewed the records from four prospective efficacy trials conducted at our institution. One hundred seventy-four infants and children received ceftriaxone and 159 received cefuroxime. The clinical characteristics of the two groups were comparable at admission. After 24 hours of therapy, routine cerebrospinal fluid cultures for all patients treated with ceftriaxone were sterile, whereas 9% of cerebrospinal fluid cultures were positive in cefuroxime-treated patients ($p < 0.001$). More cefuroxime-treated patients had abnormal physical examinations at the time of discharge than did ceftriaxone-treated patients (39/159 vs 25/174, $p = 0.02$). At 6-week and 1-year follow-up examinations, there was no longer a statistically significant difference in the incidence of neurologic abnormalities between the two therapy groups, but the incidence of hearing impairment in one or both ears was higher in the cefuroxime (18%) than in the ceftriaxone (11%) treatment group. Both regimens are efficacious for the treatment of bacterial meningitis, but some patients may not respond as satisfactorily to cefuroxime as to ceftriaxone.

Summary

Bacterial meningitis is the most common life-threatening infection in infants and children, and is a growing problem in immunocompromised patients of all ages and the elderly. McCracken has been the pre-eminent investigator of bacterial meningitis worldwide over the past 35 years. In this study, his group undertook a randomized open-label trial of a widely used third-generation cephalosporin (ceftriaxone) and a second-generation cephalosporin (cefuroxime) for treatment of bacterial meningitis in 326 children with meningitis caused by *Haemophilus influenzae* type B, *Streptococcus pneumoniae*, *Neisseria meningitidis*, or group B streptococci. All cerebrospinal fluid (CSF) isolates from infected children were susceptible to both drugs, but ceftriaxone showed approximately two-fold greater in vitro activity. Moreover, it is well known that third-generation cephalosporins penetrate the CSF more effectively than second-generation drugs. After 24 hours of therapy, all follow-up CSF cultures in the ceftriaxone group were sterile, whereas 9% of cultures were still positive in cefuroxime-treated patients ($p < 0.001$). There were no differences in mortality between the two groups (0 vs 2 deaths). Most importantly, more cefuroxime-treated patients had an abnormal neurological examination at the time of hospital discharge than did ceftriaxone-treated patients (39/159 vs 25/174, $p = 0.02$). However, at 1-year follow-up, there was no longer a significant difference in the incidence of neurological abnormalities in the two groups, other than hearing impairment in one or both ears, which was higher in children who had been treated with cefuroxime (18%) than in those who had received ceftriaxone (11%).

Citation count 48

Related references

1. Schaad UB, Suter S, Gianella-Borradori A *et al.* A comparison of ceftriaxone and cefuroxime for the treatment of bacterial meningitis in children. *N Engl J Med* 1990; **322**: 141–147.
2. Schuchat A, Robinson K, Wenger JD *et al.* Bacterial meningitis in the United States in 1995. Active Surveillance Team. *N Engl J Med* 1997; **337**: 970–976.
3. Roos KL, Tunkel AR, Scheld WM. Acute bacterial meningitis in children and adults. In: Scheld WM, Whitley RJ, Durack DT, eds. *Infections of the Central Nervous System*, 2nd edn. Philadelphia: Lippincott-Raven Publishers, 1997: 335–401.

Key message

In empiric therapy of bacterial meningitis in children (and adults), a third-generation cephalosporin, such as ceftriaxone (or cefotaxime or cefepime), is superior to a penicillin or any other cephalosporin, or the older combination of ampicillin and chloramphenicol, and should always be included in the regimen.

Why it's important

While several antibiotics traditionally used in meningitis may be effective, there are differences in their relative efficacy when compared with newer agents. This clearly illustrates not only that there may be variation in efficacy between agents, but also indicates that first line treatment strategy may need to evolve. This is particularly pertinent as the resistance spectrum of organisms evolves.

Strengths

The study was a large, prospective, randomized trial with clear-cut and vitally important outcome criteria beyond mortality, most notably, neurological residua – the greatest societal tragedy of bacterial meningitis.

Weaknesses

The study was unblinded and was done in an era before the appearance of high-level resistance of *S. pneumoniae* to penicillin.

Relevance

This study and a very similar study from Switzerland (related reference no. 1) show that if the CSF profile strongly suggests bacterial meningitis, vis-a-vis neutrophilic pleocytosis and hypoglycorrhachia, the initial regimen must provide reliable activity against *S. pneumoniae*, *H. influenzae* type B, and *N. meningitidis*, including antibiotic-resistant strains. (It should also have efficacy against *Listeria monocytogenes*, an increasingly important cause of meningitis in infants, older adults, and immunocompromised patients of any age.) A third-generation cephalosporin with activity against penicillin-resistant *S. pneumoniae* and ampicillin-resistant *H. influenzae* – such as ceftriaxone, cefotaxime, or cefepime – must be the cornerstone of the initial therapeutic regimen, and because of the growing incidence of resistance of *S. pneumoniae* to third-generation cephalosporins, should be combined with vancomycin (and, possibly, ampicillin, for optimal coverage against *L. monocytogenes*). Even with penicillin allergy, cephalosporins can usually still be given safely (and vancomycin or trimethoprim/sulphamethoxazole can be used in place of

ampicillin). With nosocomial meningitis, particularly in the setting of granulocytopenia or a CSF fistula, the initial empiric regimen should also be effective against *P. aeruginosa*: cefepime can be used with ciprofloxacin (or tobramycin) and vancomycin. If the CSF Gram stain or antigen test strongly suggest that the infecting organism is *S. pneumoniae*, and if corticosteroids are also being given, rifampicin should be added to the combination of ceftriaxone (or cefotaxime) and vancomycin. Ceftizoxime and ceftazadime, which do not have activity against resistant *S. pneumoniae*, should never be used in community-acquired meningitis.

Title

Dexamethasone therapy for bacterial meningitis: results of two double-blind, placebo-controlled trials

Author

Lebel MH, Freij BJ, Syrogiannopoulos GA, Chrane DF, Hoyt MJ, Stewart SM, Kennard BD, Olsen KD, McCracken GH Jr

Reference

N Engl J Med 1988; **319**: 964–971

Abstract

We enrolled 200 infants and older children with bacterial meningitis in two prospective double-blind, placebo-controlled trials to evaluate the efficacy of dexamethasone therapy in addition to either cefuroxime (Study 1) or ceftriaxone (Study 2). Altogether, 98 patients received placebo and 102 received dexamethasone (0.15 mg per kilogram of body weight every six hours for four days). At the beginning of therapy, the clinical and demographic characteristics of the patients in the treatment groups were comparable. The mean increase in the cerebrospinal fluid concentration of glucose, and the decreases in lactate and protein levels after 24 hours of therapy were significantly greater in those who received dexamethasone than in those who received placebo (glucose, 2.0 vs. 0.4 mmol per liter [36.0 vs. 6.9 mg per deciliter], $p < 0.001$; lactate, 4.0 vs. 2.1 mmol per liter [38.3 vs. 19.8 mg per deciliter], $p < 0.001$; and protein, 0.64 vs. 0.25 g per liter [64.0 vs. 25.3 mg per deciliter], $p < 0.05$). One patient in the placebo group in Study 1 died. As compared with those who received placebo, the patients who received dexamethasone became afebrile earlier (1.6 vs. 5.0 days; $p < 0.001$), and were less likely to acquire moderate or more severe bilateral sensorineural hearing loss (15.5 vs. 3.3 percent; $p < 0.01$). Twelve patients in the two placebo groups (14 percent) had severe or profound bilateral hearing loss requiring the use of a hearing aid, as compared with 1 (1 percent) in the two dexamethasone groups ($p < 0.001$). We conclude that dexamethasone is beneficial in the treatment of infants and children with bacterial meningitis, particularly in preventing deafness.

Summary

McCracken's group has shown in studies of animal models of bacterial meningitis and in children with meningitis that the infection produces significant inflammation of the brain and meninges, increased permeability of the blood-brain barrier, cytotoxic and vasogenic cerebral edema, and intracranial hypertension. CSF levels of TNF- α , which are normally undetectable in the absence of meningeal infection, are elevated in bacterial meningitis of childhood, and high levels are predictive of a poor outcome. Findings of therapeutic benefit with corticosteroids to suppress intracranial inflammation (as an adjunct to antimicrobial therapy) in animal models of meningitis prompted these investigators to undertake a double-blind, placebo-controlled trial in infants and older children admitted to Parkland Memorial Hospital and Children's Medical Center in Dallas with suspected bacterial meningitis. The only difference in the two protocols was that patients in the first trial received cefuroxime, whereas those in the second received ceftriaxone, both in addition to dexamethasone, 0.15 mg/kg, or placebo, every 6 hours for 4 days. Children receiving dexamethasone showed significantly lower levels of lactate and protein and higher levels of glucose in CSF after 24 hours of therapy, and defervesced much earlier (1.6 vs 5.0 days, $p < 0.001$). If they had been treated with cefuroxime, they also had fewer seizures (0 vs 4, $p = 0.05$) and subdural effusions (10% vs 20%, $p < 0.01$). Most importantly, the dexamethasone-treated children were far less likely to develop moderate or severe sensorineural

hearing loss (3.3% vs 15.5%, $p < 0.01$). Twelve patients (14%) in the placebo groups had severe or profound bilateral hearing loss requiring the use of a hearing aid, as compared with 1% in the dexamethasone group ($p < 0.001$).

Citation count 413

Related references

1. Schaad UB, Lips U, Gnehm HE, Blumberg A, Heinzer I, Wedgwood J, for the Swiss Meningitis Study Group. Dexamethasone therapy for bacterial meningitis in children. *Lancet* 1993; **342**: 457–461.
2. Girgis NI, Farid Z, Kilpatrick ME, Bishai E. Dexamethasone for the treatment of children and adults with bacterial meningitis. *Rev Infect Dis* 1990; **12**: 963–964.
3. Odio CM, Faingezicht I, Paris M *et al*. The beneficial effects of early dexamethasone administration in infants and children with bacterial meningitis. *N Engl J Med* 1991; **324**: 1525–1531.
4. McIntyre PB, Berkey CS, King SM *et al*. Dexamethasone as adjunctive therapy in bacterial meningitis. A meta-analysis of randomized clinical trials since 1988. *JAMA* 1997; **278**: 925–931.

Key message

Adjunctive therapy with the powerful and broad-spectrum anti-inflammatory, dexamethasone, significantly reduces morbidity in children with bacterial meningitis caused by *H. influenzae* type B and, possibly, *S. pneumoniae*.

Why it's important

Infection is frequently accompanied by inflammation, and while antibiotics deal with the former, morbidity and mortality may be associated with the latter. This study provides circumstantial evidence to support the theoretical argument that using steroids as adjunctive therapy to suppress inflammation may be beneficial.

Strengths

This was a large, prospective, double-blind randomized trial with standardized antibacterial therapy and clear-cut outcome measures.

Weaknesses

The study would have had greater impact had it been a multi-center trial and had the investigators done more sophisticated analyses of neurological outcome – which they did in a subsequent follow-up study (related reference no. 3). Moreover, this study (and the other studies done to date) did not have adequate numbers of patients with meningitis caused by *N. meningitidis* to be able to draw conclusions as to the efficacy of dexamethasone in meningitis caused by this ubiquitous pathogen.

Relevance

This study and those that followed show convincingly that in bacterial meningitis of childhood caused by *H. influenzae*, and probably *S. pneumoniae*, administering dexamethasone as early as possible, ideally before the first dose of antibiotics, can significantly reduce morbidity. Whereas the limited studies also suggest benefit in adults with *S. pneumoniae* meningitis, the data are not as conclusive. Moreover, there are no data to suggest benefit in bacterial meningitis caused by *N. meningitidis*, group B streptococci, or other bacterial pathogens, or for meningococcal meningitis caused by neurotropic viruses. Finally, studies to date have not shown benefit with the use of adjunctive dexamethasone for treatment of bacterial meningitis in neonates.

Title

Intensive insulin therapy in the surgical intensive care unit

Author

Van den Berghe G, Wouters P, Weekers F, Verwaest C, Bruyninckx F, Schetz M, Vlasselaers D, Ferdinande P, Lauwers P, Bouillon R

Reference

N Engl J Med 2001; **345**: 1359–1367

Abstract

BACKGROUND: Hyperglycemia and insulin resistance are common in critically ill patients, even if they have not previously had diabetes. Whether the normalization of blood glucose levels with insulin therapy improves the prognosis for such patients is not known. **METHODS:** We performed a prospective, randomized, controlled study involving adults admitted to our surgical intensive care unit who were receiving mechanical ventilation. On admission, patients were randomly assigned to receive intensive insulin therapy (maintenance of blood glucose at a level between 80 and 110 mg per deciliter [4.4 and 6.1 mmol per liter]), or conventional treatment (infusion of insulin only if the blood glucose level exceeded 215 mg per deciliter [11.9 mmol per liter], and maintenance of glucose at a level between 180 and 200 mg per deciliter [10.0 and 11.1 mmol per liter]). **RESULTS:** At 12 months, with a total of 1548 patients enrolled, intensive insulin therapy reduced mortality during intensive care from 8.0 percent with conventional treatment to 4.6 percent ($p < 0.04$, with adjustment for sequential analyses). The benefit of intensive insulin therapy was attributable to its effect on mortality among patients who remained in the intensive care unit for more than five days (20.2 percent with conventional treatment, as compared with 10.6 percent with intensive insulin therapy, $p = 0.005$). The greatest reduction in mortality involved deaths due to multiple-organ failure with a proven septic focus. Intensive insulin therapy also reduced overall in-hospital mortality by 34 percent, bloodstream infections by 46 percent, acute renal failure requiring dialysis or hemofiltration by 41 percent, the median number of red-cell transfusions by 50 percent, and critical-illness polyneuropathy by 44 percent, and patients receiving intensive therapy were less likely to require prolonged mechanical ventilation and intensive care. **CONCLUSIONS:** Intensive insulin therapy to maintain blood glucose at or below 110 mg per deciliter reduces morbidity and mortality among critically ill patients in the surgical intensive care unit.

Summary

Critically ill patients who require intensive care for >5 days have a 15–20% risk of death. Sepsis, with multi-organ dysfunction, critical-illness polyneuropathy, and heightened susceptibility to super-infection, greatly increases the risk of an adverse outcome or death. Hyperglycemia deriving from insulin resistance is extremely common in critically ill patients, even those who have not previously had diabetes and are not septic. In most ICUs, glycemic control – usually with intermittent doses of subcutaneous or intravenous insulin, guided by blood glucose measurements ('sliding scale') – is initiated when the blood glucose level approaches or exceeds 200 mg/dL. In this trial, 1548 patients in a surgical ICU who were receiving mechanical ventilation were randomly assigned to have conventional glycemic control (with a continuous infusion of insulin only if the blood glucose level exceeded 215 mg/dL, with the infusion adjusted to maintain the level between 180 and 200 mg/dL), or

intensive glycemic control (if the blood glucose exceeded 110 mg/dL, an insulin drip adjusted to maintain normoglycemia [80–110 mg/dL]). After 12 months of study, intensive glycemic control reduced mortality during ICU care from 8.0% with conventional glycemic control to 4.6% ($p < 0.04$). The benefit of intensive glycemic control was most notable for its impact on the mortality of patients who remained in the ICU for >5 days (20.2% vs 10.6%, $p = 0.005$). The greatest reduction in mortality involved deaths due to multi-organ failure with a proven septic focus. Intensive therapy reduced BSIs by 46%, acute renal failure requiring dialysis or hemofiltration by 41%, the median number of red cell transfusions by 50%, critical-illness polyneuropathy by 44%, and overall hospital mortality by 34%. The mortality of nosocomial BSI in the intensive glycemic control group (12.5%) was substantially lower than in the control group (29.5%). Patients receiving intensive glycemic control were less likely to require prolonged mechanical ventilation and intensive care.

Citation count 1707

Related references

1. McCowen KC, Malhotra A, Bistran BR. Stress-induced hyperglycemia. *Crit Care Clin* 2001; **17**: 107–124.
2. Malmberg K. Prospective randomised study of intensive insulin treatment on long-term survival after acute myocardial infarction in patients with diabetes mellitus. *BMJ* 1997; **314**: 1512–1515.
3. Malmberg K, Ryden L, Efendic S *et al*. Randomized trial of insulin-glucose infusion followed by subcutaneous insulin treatment in diabetic patients with acute myocardial infarction (DIGAMI Study): effects on mortality at 1 year. *J Am Coll Cardiol* 1995; **26**: 57–65.
4. Hawthorne G, Irgens LM, Lie RT. Outcome of pregnancy in diabetic women in North-east England and in Norway, 1994–97. *BMJ* 2000; **321**: 730–731.

Key message

Intensive glycemic control, by use of a continuous insulin infusion at a rate sufficient to maintain the blood glucose in a narrow physiologic range, 80–110 mg/dL, can greatly reduce infectious complications, associated organ failure and critical-illness polyneuropathy, and furthermore, reduces ICU and overall hospital mortality in critically ill surgical patients requiring mechanical ventilatory support.

Why it's important

It is simple, easy to understand, and is 'common sense' but it took a study to recognize the problem. A mundane part of routine practice done badly is a source of morbidity and mortality which can be demonstrably reduced by better practice. It is simple and cheap to correct. There must be other aspects of normal care that would also bear close scrutiny.

Strengths

This was a large, prospective, randomized trial, with evaluation of well-defined, clear-cut outcome measures, which showed definitive and compelling results.

Weaknesses

To achieve the level of glycemic control sought in the intensive glycemic control group, it was necessary for a team of intensive care nurses assisted by a study physician who was not involved in the clinical care of the patients to follow a strict algorithm, a luxury unavail-

able in most ICUs. Viewing the growing shortage of critical care nurses worldwide, it is unlikely that the stringent level of glycemic control achieved in the experimental group in this trial could be achieved safely in the average ICU, without putting patients in jeopardy of serious hypoglycemia. Moreover, it is unclear whether a more modest level of intensified glycemic control, such as striving to keep the blood glucose level <150 mg/dL, would provide commensurate benefit.

Relevance

The results of this study are consonant with trials in diabetic patients with acute myocardial infarction, where therapy to maintain blood glucose levels below 215 mg/dL improves the long-term outcome; and studies in diabetic pregnant women, where strict glycemic control has been shown to prevent intrauterine and perinatal death. Most notably, this study suggests that more intensive glycemic control offers the promise of remarkable global benefit to the critically ill ICU patient, including reduction of bloodstream infections, reduced organ failure and critical-illness polyneuropathy, and improved survival, particularly in patients with sepsis. The findings of this study would appear to be immediately applicable in ICUs worldwide.

Title

Prospective randomised trial of povidone-iodine, alcohol, and chlorhexidine for prevention of infection associated with central venous and arterial catheters

Author

Maki DG, Ringer M, Alvarado CJ

Reference

Lancet 1991; **338**: 339–343

Abstract

More than 90% of all intravascular device-related septicemias are due to central venous or arterial catheters. To assess the efficacy of cutaneous antisepsis to prevent catheter-associated infection, we prospectively studied three antiseptics for disinfection of patients' central venous and arterial catheter insertion sites in a surgical intensive care unit. Six hundred and sixty eight catheters were randomized to 10% povidone-iodine, 70% alcohol, or 2% aqueous chlorhexidine disinfection of the site before insertion and for site care every other day thereafter. Chlorhexidine was associated with the lowest incidence of local catheter-related infection (2.3 per 100 catheters vs 7.1 and 9.3 for alcohol and povidone-iodine, respectively, $p = 0.02$), and catheter-related bacteremia (0.5 vs 2.3 and 2.6). Of the 14 infusion-related bacteremias (4 due to contaminated infusate or catheter hub, 10 due to infected catheters), 1 was in the chlorhexidine group and 13 were in the other two groups (odds ratio 0.16, $p = 0.04$). We conclude that use of 2% chlorhexidine, rather than 10% povidone-iodine or 70% alcohol, for cutaneous disinfection before insertion of an intravascular device and for post-insertion site care can substantially reduce the incidence of device-related infection.

Summary

More than 90% of all intravascular device-related (IVDR) BSIs are caused by central venous or arterial catheters. With short-term IVDs – peripheral IV catheters, arterial catheters, and non-cuffed-non-tunnelled CVCs – most IVDR BSIs derive from skin micro-organisms at the insertion site which gain access extraluminally or, occasionally, intraluminally. Given the importance of skin micro-organisms in the pathogenesis of short-term IVDR infection, measures to reduce cutaneous colonization of the insertion site would seem to be of highest priority, particularly the choice of the chemical antiseptic used for disinfection of the insertion site. In North America, iodophors such as 10% povidone-iodine are used most widely. In this trial in a large surgical ICU, 668 CVCs and arterial catheters were randomized to have 10% povidone-iodine, 70% alcohol, or 2% aqueous chlorhexidine used for disinfection of the site before catheter insertion and for follow-up site care every other day thereafter. Chlorhexidine was associated with the lowest incidence of catheter colonization (2.3% vs 7.1% and 9.3% for alcohol and povidone-iodine, respectively, $p < 0.01$), and especially catheter-related BSI (0.5 vs 2.3 and 2.6 per 100 catheters). Of 14 IVDR BSIs overall, one occurred in the chlorhexidine group and 13 in the other two groups (odds ratio 0.16, $p = 0.04$). There were no significant differences in local inflammation of the insertion site, and no patient experienced an acute local or systemic reaction thought to represent hypersensitivity to the antiseptic solution used.

Citation count

301

Related references

1. Crnich CJ, Maki DG. The promise of novel technology for the prevention of intravascular device-related bloodstream infection. I. Pathogenesis and short-term devices. *Clin Infect Dis* 2002; **34**: 1232–1242.
2. Chaiyakunapruk N, Veenstra DL, Lipsky BA, Saint S. Chlorhexidine compared with povidone-iodine solution for vascular catheter-site care: a meta-analysis. *Ann Intern Med* 2002; **136**: 792–801.
3. Maki DG, Stolz SM, Wheeler S, Mermel LA. Prevention of central venous catheter-related bloodstream infection by use of an antiseptic-impregnated catheter. A randomized, controlled trial. *Ann Intern Med* 1997; **127**: 257–266.

Key message

Chlorhexidine 2% is superior to 10% povidone-iodine or 70% alcohol for disinfection of the IVD insertion site, and can reduce the substantial risk of BSI associated with CVCs of all types and arterial catheters in the ICU.

Why it's important

Not all antiseptics are equal. The simple choice of antiseptic may be a cost-effective means of reducing the incidence of a common problem.

Strengths

This was a prospective, randomized trial with simple, but clear-cut outcome criteria and conclusive results.

Weaknesses

The study was not blinded, a problem which has not yet been resolved because of the inability of manufacturers to tint chlorhexidine solutions similar to iodophors. Moreover, the study was a single-center study and would have had greater authority had it been larger and carried out in multiple centers. Finally, the study did not utilize molecular subtyping of catheter and blood isolates to conclusively prove the origin of every BSI, and did not evaluate the impact of chlorhexidine antiseptics on the susceptibility of colonizing or infecting micro-organisms to chlorhexidine. (Subsequent studies by these investigators incorporated these features into their trials, and have shown that cutaneous antiseptics with chlorhexidine has no measurable effect on the chlorhexidine susceptibility of infecting organisms.)

Relevance

This study (and seven follow-up trials) shows convincingly that chlorhexidine is a superior agent for cutaneous antiseptics before insertion of IVDs and in their follow-up site care. Moreover, it does not appear that use of chlorhexidine for cutaneous antiseptics promotes the emergence of chlorhexidine-resistant strains. Two recent meta-analyses of the eight randomized trials (related references, nos 1 and 2) have shown that chlorhexidine is clearly superior to iodophors for prevention of catheter colonization and catheter-related BSI, and indicate that at the present time chlorhexidine should be the antiseptic of first choice for vascular access. The 2002 CDC Hospital Infection Control Practices Advisory Committee (HICPAC) Guideline now recommends that 2% chlorhexidine solution be the agent of first choice for cutaneous antiseptics for vascular access. Follow-up randomized trials have shown that the use of a chlorhexidine-impregnated sponge IVD site dressing (related reference no. 1) or use of a central venous CVC impregnated with chlorhexidine and silver-sulphadiazine (related reference no. 2) each significantly reduce the incidence of IVDR BSI.

Infectious diseases: an intensive care clinician's perspective

Neil Soni

Introduction

'Infectious disease is one of the great tragedies of living things – the struggle for existence between different forms of life.' Hans Zinsser

This chapter is intended to complement the chapter on infection in the ICU by Dennis Maki for two reasons. The first is that infectious disease is a massive topic, and could easily be the subject of a 'classics' book in its own right. Secondly, it is intended to provide the slightly tangential perspective that might be anticipated by addressing the problem from different base specialities. It is inevitable that there is some overlap, but when that occurs, the emphasis is quite different. I have selected what I consider to be a key paper in each of several fields, and to me, these are papers that have important messages that have been, or could have been, crucial in the development of the field.

Infectious disease has been the bane of clinicians' lives since time immemorial, but it was on 19 February 1878 that Pasteur argued the case for the germ theory of infection at the French Academy of Medicine, and followed this with a paper in association with Jules Joubert and Charles Chamberland in the same year. The concept of micro-organisms was born, and 130 years later is a daily preoccupation in every critical care unit.

To start, I have chosen an historical text that is a marvelous exposition of the socio-political power of infection, as a reminder of the historical significance of infectious disease. I have then proceeded to focus on the following somewhat disparate areas under the umbrella of infectious disease and infection control. The former incorporates the observation that over the last 50 years, several new diseases have been discovered or uncovered. The latter, infection control, is part of the rather unpleasant reality that in the intensive care unit, iatrogenic and acquired secondary problems are common, in particular, nosocomial infection. Therefore, of necessity, infection control has a leading role in our current ICU practice. This is less glamorous than other aspects of critical care in this book, but does encompass a large range of very real problems, and, with reference to the historical text, does constitute a daily battle to control contagion.

New diseases have had the most impact outside of the ICU, but they have introduced new horizons in critical care. The single most important new disease has been HIV infection, the discovery of which is an extraordinary story. The disease has become an immense problem worldwide, but it has also had implications for critical care practice. These have been wide ranging – from medical management, through rapidly changing understanding of immunology, and into the realms of ethics (Notterman 1993, Wachter and Lo 1993). There then followed an evolution in critical care management of the disease, which continues even now as treatments change. At a time when information was woefully lacking as regards the benefits of critical care, the paper discussed provided some guidance. One of the original papers describing the new syndrome and a later critical care paper discussing management have been selected for comment, papers 2 and 3. The other new disease that became a recognized problem was Legionella, or Legionnaires disease, which initially became part of medical vocabulary through the popular press. It is now a standard part of working up atypical pneumonias, and has quietly become a part of our differential diagnosis (Fraser *et al* 1977, Terranova *et al* 1978).

Infection control is the other area to be considered. The ICU is a fertile source of nosocomial problems. Key to recognizing these problems is a clear view of how common they are, and also what organisms tend to be involved, particularly resistant organisms. The EPIC study (paper 4) was a snapshot of infection on a single day across Europe. This was a spectacular success, and the paper is widely quoted. It is a classic, and has contributed significantly both to clinical knowledge and to the concept of Europe-wide studies in critical care. On the down side, it should be taken as a demographic snapshot, and not given scientific credibility where it is unwarranted.

A useful observation in EPIC was the prevalence of resistance. Antibiotic resistance effectively provides new versions of old diseases that have arisen through the phenomenal ability of organisms to meet and beat the challenge of our best efforts to restrain them. Resistance to antimicrobial agents and hospital colonization has made several organisms household names, and created renewed interest in infection control. For this topic, I have chosen a neglected study about methicillin-resistant *Staphylococcus aureus* (MRSA) that looked at the clinical relevance of the resistant organism rather than just its resistance pattern (paper 5). The story of its emergence illustrates the likely pattern of resistance problems to come, in the guise of acinetobacter and resistant tuberculosis, which may well have far greater clinical impact. (Irwin *et al* 1980, Gomez *et al* 1999, Garcia *et al* 2001, Hannan *et al* 2001).

Nosocomial infection is a problem in every intensive care unit in the world. The paper chosen here (paper 6) was one of the earliest to try to determine the role of the device versus the role of the patient in ventilator-associated pneumonia. Many better-known papers followed, but this observational study was, in my view, key to our current understanding.

Central venous catheters are a conduit into the circulation, and may have a more direct iatrogenic significance. A classic study has been selected that challenged conventional practice and encouraged increased investigative interest in our routine practices in the ICU.

I have used the opportunity to include one of my favorite medical papers, because it is entertaining and informative despite being the biography of a bug (paper 8). It is about a single bacterium that is a relatively minor player in nosocomial infection. Before this article, I could not spell it, and that has not changed, but the article has broadened my view both of the bug and of microbiology.

It is difficult to know where to place candida infection, but it should be mentioned, as management has evolved over the last few years and is set to evolve further, with new treatments becoming available. Paper 9 was a milestone in the treatment of candida.

Invasive technologies bring hazards to both patients and staff, and so the issue of blood-borne infection and transmission from patients to staff and vice versa was discovered with early dialysis units. This is illustrated by paper 10. Now the risks include hepatitis C, HIV, and prions.

To finish on the ongoing problems of infection control, the classic paper by Pittet on handwashing is a reminder to get the fundamentals right. Elsewhere in this book, new, exciting, and heroic treatments whose efficacy is hard to demonstrate are discussed, but here a simple basic routine can be shown to have a detectable clinical impact.

References

- Fraser DW, Tsai TR, Orenstein W *et al*. Legionnaires' disease: description of an epidemic of pneumonia. *N Engl J Med* 1977; **297**: 1189–1197.
- Garcia Garmendia JL, Ortiz Leyba C, Garnacho Montero J *et al*. Risk factors for *Acinetobacter baumannii* nosocomial bacteremia in critically ill patients: a cohort study. *Clin Infect Dis* 2001; **33**: 939–946.

Gomez J, Simarro E, Banos V *et al*. Six-year prospective study of risk and prognostic factors in patients with nosocomial sepsis caused by *Acinetobacter baumannii*. *Eur J Clin Microbiol Infect Dis* 1999; **18**: 358–361.

Hannan MM, Peres H, Maltez F *et al*. Investigation and control of a large outbreak of multi-drug resistant tuberculosis at a central Lisbon hospital. *J Hosp Infect* 2001; **47**: 91–97.

Irwin RS, Demers RR, Pratter MR *et al*. An outbreak of acinetobacter infection associated with the use of a ventilator spirometer. *Respir Care* 1980; **25**: 232–237.

Notterman DA. Pediatric AIDS and critical care. *Crit Care Med* 1993; **21** (9 Suppl): S319–S321.

Terranova W, Cohen ML, Fraser DW. 1974 outbreak of Legionnaires' Disease diagnosed in 1977. Clinical and epidemiological features. *Lancet* 1978; **2**: 122–124.

Wachter RM, Lo B. Advance directives for patients with human immunodeficiency virus infection. *Crit Care Clin* 1993; **9**: 125–136.

Title***Rats lice and history***

Author

Zinsser H

Reference

Printed in Boston for The Atlantic Monthly Press by Little Brown and Company, 1935

Abstract

None

Summary

Described by the author as the biography of typhus fever, this book illustrates in some graphic detail the impact of this and other infectious diseases on the history of mankind. In general, sociologists, historians, and commentators have tended to ignore the influence of infectious disease in the rise and fall of not only nations, but also civilizations. Typhus was selected because it has been more intimately influential in the history of mankind than even malaria, cholera, dysentery, or, from an economic stance, the tsetse fly. Examples of individual diseases creating havoc in new environments abound. These include the decimation of a quarter of the population of Fiji by measles in 1875, the effect of tuberculosis on the Eskimos, and the introduction of smallpox to Mexican Indians by the ship *Narvaez*.

The author documents probable outbreaks of typhus from 1083, in a monastery near Salerno, through to better documentation in 1490, where it was observed in Granada that 20,000 men were missing from the army roll: 3000 had been killed in combat, but 17,000 succumbed to typhus. In 1527, the imminent fall of Naples, which would have meant the defeat of Italy and the Pope, was averted when the besieging army lost most of its 25,000 men to typhus. A few years later, the conquistadors introduced this disease and smallpox to South America, rapidly destroying a significant part of the population, and aiding the downfall of that civilization. Throughout that century in Europe, typhus and plague decimated armies and altered the course of history. Typhus has always followed the armies of Europe, and where there was strife and a breakdown of social infrastructure, typhus re-emerged. At the start of the 20th century, with better education and the adoption of concepts of hygiene, in company with relative peace, the epidemics retreated and typhus was almost unheard of. However, wherever famine or warfare took place, typhus re-emerged, and it did so with a vengeance during World War I. It emerged first in Serbia with devastating effect, and from a clinician's viewpoint, it is interesting to note that at least 126 of the 400 army doctors succumbed to the disease. From then on, typhus followed the population and the army, and thousands died. After that war, the disease decreased as peace reigned; however, the author comments that it has not gone away, but is merely hiding. He ends with the optimistic note that this disease can be defeated and eliminated.

Citation count

Not applicable

Related references

1. Osler W. *The Principles and Practice of Medicine*. New York: D. Appleton and Co., 1892: Section 1, p. 39.
2. Fagge C. *Faggges Principles and Practice of Medicine*. London: J & A Churchill, 1886: 139.

Key message

1. Infectious diseases have had a massive impact on mankind.
2. Civil disruption and the breakdown of infrastructure are associated with the emergence of infectious disease.
3. Immunologically naïve populations are extremely vulnerable.
4. In the past, at least, the destructive power of organisms has far exceeded that of the military forces.

Why it's important

The influence of infectious disease is usually overlooked. We are entering a new era. The complacency associated with the eradication of smallpox, the control of malaria, the 'dumbing down' of TB, and the efficacy of antibiotics is being replaced by anxiety, as there is realization that victory and control may have been a temporary phenomenon. That realization, associated with the emergence of new disease entities such as HIV, should remind us of the destructive nature of infectious disease and alert us to complacency in our own local microbiological war zones – i.e. the field of critical care.

Strengths

This is an interesting book – blending history and politics with science and philosophy. It takes a broad historical view of a particular disease to illustrate that this story could be applied to many infectious diseases.

Weaknesses

Much of the early documentation is very subjective and is partly guesswork as to the disease. There is no reference to the plague of Athens recorded by Thucydides, which was probably typhus, nor is there comment on the diseases known as camp fever, military fever, spotted fever, brain fever, or putrid fever, all of which were probably typhus. Typhus was only named in 1760, by Sauvages. It is not very scientific, and would be difficult to place on an evidence-based scale.

Relevance

On the horizon are many problems in infectious disease. Multi-resistance to current antibiotics produces the spectre of known diseases without effective treatment. Other diseases such as HIV are controlled, but not cured. Bioterrorism and the potential use of infective agents, including some that were thought to have been eradicated, is being discussed, and no longer seems an impossibility. This book is a reminder of our vulnerability.

Title

Pneumocystis carinii pneumonia and mucosal candidiasis in previously healthy homosexual men: evidence of a new acquired cellular immunodeficiency

Author

Gottlieb MS, Schroff R, Schanker HM, Weisman JD, Fan PT, Wolf RA, Saxon A

Reference

N Engl J Med 1981; **305**: 1425–1431

Abstract

Four previously healthy homosexual men contracted *Pneumocystis carinii* pneumonia, extensive mucosal candidiasis, and multiple viral infections. In three of the patients, these infections followed prolonged fevers of unknown origin. In all four, cytomegalovirus was recovered from secretions. Kaposi's sarcoma developed in one patient 8 months after he presented with esophageal candidiasis. All patients were anergic and lymphopenic; they had no lymphocyte proliferative responses to soluble antigens, and their responses to phytohemagglutinin were markedly reduced. Monoclonal antibody analysis of peripheral blood T cell subpopulations revealed virtual elimination of the Leu-3/helper/inducer subset, an increased percentage of the Leu-2+ suppressor/cytotoxic subset, and an increased percentage of cells bearing the thymocyte-associated antigen T10. The inversion of the T/helper to suppressor/cytotoxic ratio suggested that cytomegalovirus infection was an important factor in the pathogenesis of the immunodeficient state. A high level of exposure of male homosexuals to cytomegalovirus-infected secretions may account for the occurrence of this immune deficiency.

Summary

The presenting histories of these patients did not suggest a known cause for immune deficiency. All the patients had persistent fever over the preceding weeks, as well as evidence of opportunistic infection. This included cytomegalovirus. As the patients were all homosexual, the authors suggested that sexual transmission of an infectious agent might be involved. The authors presented these cases as a new syndrome, and concluded that this new syndrome represented a potentially transmissible immune deficiency.

Citation count 1842

Related references

1. Anonymous. Opportunistic infections and Kaposi's sarcoma among Haitians in the United States. *MMWR Morbid Mortal Wkly Rep* 1982; **31**: 353–354, 360–361.
2. Landesman SH, Vieira J. Acquired immune deficiency syndrome (AIDS). A review. *Arch Intern Med* 1983; **143**: 2307–2309.
3. Habibi B, Allain JP, Courouce AM. Transfusions sanguinees et syndrome d'immunodépression acquise (SIDA). *Rev Fr Transfus Immunohematol* 1983; **26**: 447–465.
4. Pape JW, Liataud B, Thomas F *et al.* Characteristics of the acquired immunodeficiency syndrome (AIDS) in Haiti. *N Engl J Med* 1983; **309**: 945–950.

Key message

A new disease entity emerged in Western society. In an era of scientific method, a pattern of clinical presentation was recognized. With limited information available, the authors identified and described many of the clinical features of the disease, anticipated its primary mode of spread, and even suggested a viral etiology. There are probably more 'new' diseases out there.

Why it's important

In retrospect, it can be seen that these clinicians described a new pattern that did not fit with their previous experience, and demonstrated that clinical practice requires an open mind. This was the discovery of the disease that has had a significant impact in many areas, including critical care.

Strengths

This is, in essence, a case report, albeit embellished with some immunology. It is a marvelous example of observation and rational thought that led to conclusions at that stage that anticipated the much later more formal descriptions of the disease. It is a tribute to clinical acumen.

Weaknesses

It is a case report, and would not rate very highly in an evidence-based review. The authors discussed possible issues broadly, and were keen to invoke cytomegalovirus as a cause rather than an effect.

Relevance

The discovery of a new disease that has since reached epidemic proportions throughout the world is relevance enough. The paper was a source of interest and incredulity initially, and was not considered very relevant to the critical care community at the time. Subsequently, HIV disease has become an integral part of critical care practice in many parts of the world. The discovery and, in particular, the time between this paper and identification of the causal agent, had a significant impact on the complacency of Western medicine.

Title

Pneumocystis carinii pneumonia and respiratory failure in AIDS: improved outcomes and increased use of intensive care units

Author

Wachter RM, Russi MB, Bloch DA, Hopewell PC, Luce JM

Reference

Am Rev Respir Dis 1991; **143**: 251–256

Abstract

To determine whether the outcome of intensive care for patients with AIDS, *Pneumocystis carinii* pneumonia (PCP), and respiratory failure has changed, we studied patients admitted to the intensive care units at San Francisco General Hospital from 1981 to 1988. We compared the course of patients with PCP and respiratory failure admitted to the intensive care unit from 1986 to 1988 with a similar cohort hospitalized from 1981 to 1985. The hospital survival rate for the 35 patients in the 1986 to 1988 cohort was 40%, compared with 14% for the 42 patients in the 1981 to 1985 cohort ($p < 0.01$). Age, episode of PCP, time since AIDS diagnosis, anti-PCP therapy, and important clinical variables were similar in both cohorts. Corticosteroids were used commonly in the recent era. Patients who received steroids had an in-hospital survival rate of 46%, compared with 22% for those who did not receive steroids ($p = \text{NS}$). In a stepwise logistic regression model, ICU care in the recent era and higher serum albumin at the time of ICU admission were the only variables significantly associated with survival. The hospital survival of patients with PCP and respiratory failure has improved. The improvement could not be explained by patient selection or by better anti-PCP therapy. The apparent beneficial effect of corticosteroids deserves further study. The improvement in ICU outcome was reflected in increased ICU utilization by patients with AIDS, PCP, and respiratory failure.

Summary

This is a cohort study looking at survival in patients admitted to an ICU with respiratory failure and PCP in the early 1980s compared with the late 1980s. Observations on improved survival are made, and there is discussion of why there was an apparent improvement in outcome.

Citation count

62

Related references

1. Azoulay E, Parrot A, Flahault A *et al.* AIDS-related *Pneumocystis carinii* pneumonia in the era of adjunctive steroids: implication of BAL neutrophilia. *Am J Respir Crit Care Med* 1999; **160**: 493–499.
2. Bedos JP, Dumoulin JL, Gachot B *et al.* *Pneumocystis carinii* pneumonia requiring intensive care management: survival and prognostic study in 110 patients with human immunodeficiency virus. *Crit Care Med* 1999; **27**: 1109–1115.
3. Brenner M, Ognibene FP, Lack EE *et al.* Prognostic factors and life expectancy of patients with acquired immunodeficiency syndrome and *Pneumocystis carinii* pneumonia. *Am Rev Respir Dis* 1987; **136**: 1199–1206.
4. Rosenberg AL, Seneff MG, Atiyeh L, Wagner R, Bojanowski L, Zimmerman JE. The importance of bacterial sepsis in intensive care unit patients with acquired immunodeficiency syndrome: implications for future care in the age of increasing antiretroviral resistance. *Crit Care Med* 2001; **29**: 548–556.

5. Afessa B, Green B. Bacterial pneumonia in hospitalized patients with HIV infection: the Pulmonary Complications, ICU Support, and Prognostic Factors of Hospitalized Patients with HIV (PIP) Study. *Chest* 2000; **117**: 1017–1022.
6. Randall Curtis J, Yarnold PR, Schwartz DN, Weinstein RA, Bennett CL. Improvements in outcomes of acute respiratory failure for patients with human immunodeficiency virus-related *Pneumocystis carinii* pneumonia. *Am J Respir Crit Care Med* 2000; **162** (2 Pt 1): 393–398.

Key message

The in-hospital survival rates in patients admitted to the ICU with pneumocystis pneumonia were not as bad as had been thought previously. Steroids were one of the few 'changes' in therapy over that time period, and the in-hospital mortality in patients given steroids was lower than those not given steroids. Statistically, steroids could not be shown to be efficacious because of the limited numbers. The APACHE II score was not helpful in predicting survival. The 1-year survival in the era II patients was only 9% by Kaplan-Meier survival curve.

Why it's important

At the time, there was little or no guidance on critical care management of these patients. The general impression was that the outcome was dismal. This paper sought to clarify the position, demonstrated a change over the preceding years, and suggested that ICU could be more beneficial than previously thought. It highlights the importance of having current information with which to guide decision-making, and the fact that publishing outcomes can be helpful.

Strengths

Detailed information about patients in respiratory failure had been collected over a long time period. It provided information about those sick enough to warrant ICU in a relatively uncommon disease. It was observational in nature, but thereby provided survival data.

The discussion is very detailed, and considers thoroughly the apparent effects of steroids, but also explains that when the patients were stratified within the latter part of the study, the numerical differences disappeared.

The discussion is an extremely forthright critique of the data and its possible interpretations. The authors made no extravagant claims from this study, but rather used it as a discussion document to ask questions and raise issues.

Weaknesses

It was a retrospective cohort study comparing different time periods with different approaches to treatment, in particular the use of steroids. In the summary, the in-hospital survival of those patients given steroids was 45%, compared with 22% for those not given steroids. This is confusing given that the authors, in the discussion, say it was hard to see a difference when the second tranche of patients was stratified.

In other aspects of the study, there may have been different patient selection, although the authors went to some trouble to try to evaluate this factor. There were very small cohorts of 42 and 35 patients, and so many of the findings were observations of trends, and were not, and would not, be expected to be statistically significant.

Relevance

This was the best information that we had in terms of guidance, and it was a sensible and considered evaluation of what was being attempted at that time. It illustrates how important it is to monitor clinical outcomes during the evolution of the management of a disease.

Title

The prevalence of nosocomial infection in intensive care units in Europe: results of the European Prevalence of Infection in Intensive Care (EPIC) Study, EPIC International Advisory Committee

Author

Vincent JL, Bihari DJ, Suter PM, Bruining HA, White J, Nicolas-Chanoin MH, Wolff M, Spencer RC, Hemmer M

Reference

JAMA 1995; **274**: 639–644

Abstract

To determine the prevalence of intensive care unit (ICU)-acquired infections and the risk factors for these infections, identify the predominant infecting organisms, and evaluate the relationship between ICU-acquired infection and mortality. DESIGN – A 1-day point-prevalence study. SETTING – Intensive care units in 17 countries in Western Europe, excluding coronary care units and pediatric and special care infant units. PATIENTS – All patients (>10 years of age) occupying an ICU bed over a 24 hour period. A total of 1417 ICUs provided 10,038 patient case reports. MAIN OUTCOME MEASURES – Rates of ICU-acquired infection, prescription of antimicrobials, resistance patterns of microbiological isolates, and potential risk factors for ICU-acquired infection and death. RESULTS – A total of 4501 patients (44.8%) were infected, and 2064 (20.6%) had ICU-acquired infection. Pneumonia (46.9%), lower respiratory tract infection (17.8%), urinary tract infection (17.6%), and bloodstream infection (12%) were the most frequent types of ICU infection reported. Most frequently reported micro-organisms were Enterobacteriaceae (34.4%), *Staphylococcus aureus* (30.1%; [60% resistant to methicillin]), *Pseudomonas aeruginosa* (28.7%), coagulase-negative staphylococci (19.1%), and fungi (17.1%). Seven risk factors for ICU-acquired infection were identified: increasing length of ICU stay (>48 hours), mechanical ventilation, diagnosis of trauma, central venous, pulmonary artery, and urinary catheterization, and stress ulcer prophylaxis. ICU-acquired pneumonia (odds ratio [OR], 1.91; 95% confidence interval [CI], 1.6 to 2.29), clinical sepsis (OR, 3.50; 95% CI, 1.71 to 7.18), and bloodstream infection (OR, 1.73; 95% CI, 1.25 to 2.41) increased the risk of ICU death. CONCLUSIONS – ICU-acquired infection is common and often associated with microbiological isolates of resistant organisms. The potential effects on outcome emphasize the importance of specific measures for infection control in critically ill patients.

Summary

This was a microbiological snapshot of Europe with significant involvement of many countries. The study identified the organisms perceived to be a problem on a particular day, and also looked at outcome up to 6 weeks after that date. A wide range of risk factors was also collected. A wealth of data were produced relating to patient populations, risk factors, organisms, and outcomes. The results indicated a high prevalence rate of ICU-acquired infection, and the relative importance of nosocomial pneumonia, which accounted for >50% of all infections. The study showed that nosocomial infection was associated with an increased risk of death, but did not necessarily increase mortality.

Citation count

1009

Related references

1. Donowitz LG, Wenzel RP, Hoyt JW. High risk of hospital-acquired infection in the ICU patient. *Crit Care Med* 1982; **10**: 355–357.
2. Tejada Artigas A, Bello Dronda S, Chacon Valles E *et al*. Risk factors for nosocomial pneumonia in critically ill trauma patients. *Crit Care Med* 2001; **29**: 304–309.
3. Barsic B, Beus I, Marton E, Himbele J, Klinar I. Nosocomial infections in critically ill infectious disease patients: results of a 7-year focal surveillance. *Infection* 1999; **27**: 16–22.
4. Bergmans DC, Bonten MJ, Gaillard CA *et al*. Indications for antibiotic use in ICU patients: a one-year prospective surveillance. *J Antimicrob Chemother* 1997; **39**: 527–535.

Key message

- Nosocomial infection is common.
- There appears to be considerable variation between countries.
- There are frequently resistant organisms.
- Invasive procedures, such as venous or urinary catheterization, intubation, and ventilation, were identified as risk factors.

Why it's important

It gives a view of nosocomial infection across Europe. This was the first major attempt to identify the demography of ICU infection across Europe. It involved the cooperation of 14 countries, 1417 intensive care units, and 10,000 patients, and this was a genuine Europe-wide venture involving the critical care community. It showed it could be done.

Strengths

The sheer size of the project, with 10,000 patients and such a large number of units spread so widely across so many countries with different health service infrastructures. It has established the technique of 'snapshots' in Europe as an observational method.

Weaknesses

This was a heterogeneous population in terms of patients, units, and countries. The paper seeks to derive a large amount of information from a wealth of data. Some of the results are surprising – such as 17% fungal infection. This raises issues as to how this could come about, such as by over-reporting, lack of definition between colonization and infection, and inaccuracy. This could be extrapolated to the other results. The huge differences between countries may be real, or may reflect reporting techniques. This was a survey, and it was unrealistic to consider subjects such as attributable mortality from such data.

The most contentious aspect of this regularly quoted survey is that the data are held in far higher esteem than is sensible for a 1-day snapshot. Given the nature of this survey, the authors asked too many questions, derived too many answers, and presented the results as if it were a tightly controlled trial complete with convincing statistics. In other words, a silk purse from a sow's ear.

Relevance

The clinical relevance is that the suspicions we had about the prevalence of nosocomial infection have been confirmed, and that there is more of it in patients who have or need invasive interventions. The organisms acquired in ICUs tend to be resistant.

From a European perspective, a massive multi-center cooperative study has taken place successfully, and this sets the scene for more collaborative work in the European critical care community.

Title

What's in a name: is methicillin-resistant Staphylococcus aureus just another S. aureus when treated with vancomycin?

Author

McManus AT, Mason AD Jr, McManus WF, Pruitt BA Jr

Reference

Arch Surg 1989; **124**: 1456–1459

Abstract

Methicillin-resistant *Staphylococcus aureus* (MRSA) strains, principally resistant to penicillinase-resistant penicillins and aminoglycosides, are increasingly common hospital isolates. We have examined the significance of MRSA colonization and infection in 1100 consecutively admitted, seriously burned patients in whom vancomycin was used to treat all staphylococcal infections. Colonization with *S. aureus* (SA) was identified in 658 patients, in 319 of whom MRSA colonization was identified. Two hundred fifty-three SA infections occurred in 178 patients; of these infections, 58% were pulmonic and 38% were bacteremic. Methicillin-resistant SA infections occurred in 58 of the SA-infected patients. A severity index, based on multiple-regression analysis of mortality as a function of burn size and age in the study population, was used to estimate expected mortality. We demonstrated no measurable increase in mortality attributable to MRSA in this population of burned, SA-infected patients.

The results question the clinical and economic value of added control practices, such as closing of units, refusal of transfer or admission, added isolation, treatment of carriers, furlough of colonized staff, and other expensive measures that are specifically directed at prevention of MRSA infections in critical care areas.

Summary

The clinical impact of MRSA was assessed in a burn unit. Without challenging the clinical problems of staphylococcal infection overall, the authors showed that no excess attributable mortality could be linked to MRSA per se. The authors use this message to question the wisdom of employing draconian infection control measures for this particular organism.

Citation count 46

Related references

1. Stewart G. Changes in sensitivity of staphylococci to methicillin. *BMJ* 1961; **1**: 863–866.
2. Theaker C, Ormond-Walsh S, Azadian B, Soni N. MRSA in the critically ill. *J Hosp Infect* 2001; **48**: 98–102.
3. McDonald M, Hurse A, Sim KN. Methicillin-resistant *Staphylococcus aureus* bacteraemia. *Med J Aust* 1981; **2**: 191–194.
4. Hannan MM, Peres H, Maltez F *et al*. Investigation and control of a large outbreak of multi-drug resistant tuberculosis at a central Lisbon hospital. *J Hosp Infect* 2001; **47**: 91–97.

Key message

In burn patients (who are among the most vulnerable patients seen), it was difficult to find attributable mortality from MRSA beyond what would be seen with non-resistant staphylococci. This contrasted with the findings of dramatically increased mortality with gram-negative bacteremia. The infection control measures used to reduce gram-negative cross-infection were not as effective for staphylococci.

Why it's important

This paper challenged the prevailing dogma of the time. It emphasizes the importance of knowing the clinical significance of a problem so that it can be kept in perspective. It also alluded to the difficulties that would be encountered with multi-resistant gram-negative organisms, which have never enjoyed the stardom of MRSA, but probably are of far greater importance. The paper indicates that the authors could control gram-negative organisms more easily than MRSA.

Strengths

The study set out to identify the clinical importance and pathogenic significance of MRSA in a burn unit for 1100 consecutively admitted burn patients with severe injuries (mean burn size 40%). Infections and antibiotic usage were documented using prospective protocols and clinical assessment by a protocol that was checked. It used clear documentation of episodes of infection.

Weaknesses

Observational study over a 6 year period with an internal comparator, i.e. MSSA. The preceding gram-negative bacteremia study looked at the influence of bacteremia and showed that gram-negative bacteremia is a major clinical problem. It is a source of confusion because this study compared MSSA with MRSA, and made no comment on the clinical relevance of any staphylococcal bacteremia. The authors did comment that as an infection it can be easily identified, has known sensitivity, and frequently responds well to prompt treatment.

Relevance

Since MRSA first appeared, it has enjoyed more attention as regards infection control than any other organism. Terror of the consequences led to draconian methods of control and elimination with isolation of patients, cancellation of cases, and closure of both operating theaters and critical care units. All of these measures had morbidity and mortality associated with them, none of which was documented. This study questioned the real clinical significance of this organism beyond that of its non-resistant counterpart. The paper was completely ignored, and as far as I am aware, had no effective impact. In contrast, MRSA became the *cause célèbre* of Infection Control. Years later, other studies appeared to show similar results. Unfortunately, the situation is out of control, as the popular press are now on the case.

This paper also drew attention to the genuine easily identified morbidity and mortality associated with gram-negative organisms. While MRSA is, at present, easily identified and treated, *Acinetobacter* *stenotrophomonas* and other organisms are harder to find, increasingly resistant, and demonstrably lethal.

It is hard to see what has been usefully achieved with MRSA since 1989. If this classic paper had been taken on board – particularly as regards antibiotic usage – it is conceivable that we would be better placed to deal with the newer villains on the horizon.

Title

Role of respiratory assistance devices in endemic nosocomial pneumonia

Author

Cross AS, Roup B

Reference

Am J Med 1981; **70**: 681–685

Abstract

The role of respiratory assistance devices and techniques in the acquisition of endemic hospital-associated pneumonia was prospectively studied in 13,086 patients over 11 months. Of these, 914 (7 percent) had a respiratory assistance device for at least 24 hours. Cultures of respirator effluent air and nebulizer fluid (taken after 24 hours), tracheostomy sites, and irrigating solutions and respirometers were obtained in the 144 of 914 patients who had a respiratory assistance device for at least 72 hours. There were 108 episodes of hospital-associated pneumonia in 107 patients (0.82 percent incidence). Gram-negative organisms were associated with 70 percent of these episodes, and *Strep. pneumoniae* with 5 percent. The risk of hospital-associated pneumonia was 0.3 percent in patients without a respiratory assistance device (35 percent of total hospital-associated pneumonia) versus 1.3 percent with endotracheal tubes and respirators (11 percent of hospital-associated pneumonia), 25 percent with tracheostomy (12 percent of hospital-associated pneumonia), and 66 percent in patients with tracheostomy and a respirator (9 percent of hospital-associated pneumonia). No case of hospital-associated pneumonia occurred in patients on respirators less than 24 hours, but the risk of hospital-associated pneumonia increased significantly after the fifth day of therapy. None of the 63 cultures of nebulizer fluid was positive. Although positive cultures of respiratory effluent, tracheal suction fluid, or respirometer were not predictive of the acquisition of hospital-associated pneumonia, nine of 107 patients acquired this infection after a previously positive culture of a respiratory assistance device, and in five instances with the same organism. Since contaminated respiratory assistance devices are rarely a direct cause of hospital-associated pneumonia, routine in-use monitoring of respiratory assistance devices does not appear warranted.

Summary

Patients who need respiratory assistance, particularly as regards invasive methods, are at risk of developing nosocomial infection. The organisms are usually gram-negative and do not normally derive from the invasive devices themselves.

Citation count 198

Related references

1. Fagon JY, Chastre J, Hance AJ, Montravers P, Novara A, Gibert C. Nosocomial pneumonia in ventilated patients: a cohort study evaluating attributable mortality and hospital stay. *Am J Med* 1993; **94**: 281–288.
2. Johanson WG Jr, Pierce AK, Sanford JP, Thomas GD. Nosocomial respiratory infections with gram-negative bacilli. The significance of colonization of the respiratory tract. *Ann Intern Med* 1972; **77**: 701–706.

3. Torres A, Aznar R, Gatell JM *et al*. Incidence, risk, and prognosis factors of nosocomial pneumonia in mechanically ventilated patients. *Am Rev Respir Dis* 1990; **142**: 523–528.
4. Ashbaugh DG, Petty TL. Sepsis complicating the acute respiratory distress syndrome. *Surg Gynecol Obstet* 1972; **135**: 865–869.
5. Hospital-acquired pneumonia in adults: diagnosis, assessment of severity, initial antimicrobial therapy, and preventive strategies. A consensus statement, American Thoracic Society, November 1995. *Am J Respir Crit Care Med* 1996; **153**: 1711–1725.
6. Anonymous. Guidelines for prevention of nosocomial pneumonia. Centers for Disease Control and Prevention. *MMWR Morbid Mortal Wkly Rep* 1997; **46** (Rr-1): 1–79 [<http://www.epo.cdc.gov/wonder/PrevGuid/m0045365/m0045365.asp>].

Key message

- Patients who need respiratory assistance are at substantial risk of nosocomial infection.
- The devices themselves are rarely the source.
- Gram-negative organisms are usually involved.
- The infection rate increased with time ventilated.

Why it's important

At this time, nosocomial pneumonia was clearly identified as a problem and invasive respiratory devices were implicated heavily. This was the first study to suggest that the patients and the underlying problems that necessitated invasive respiratory support were of greater significance than the devices themselves. While not exonerating tracheostomies and endotracheal tubes, this study suggested that there were other more important sources of this kind of nosocomial infection. Gram-negative organisms were the main villains, a situation that remains unchanged.

Strengths

The study was focused on the role of invasive devices. There was a large number of patients; 12,172 were screened, and 107 patients had episodes that met the criteria for nosocomial infection. The organisms were recorded.

Weaknesses

This was an observational study with a relatively small group of patients with nosocomial pneumonia.

Relevance

Then as now, the role of invasive ventilation and respiratory devices was clearly shown. The fact that the devices themselves were not the direct cause of the infection is important and has been confirmed subsequently. It was clearly shown that it is the patient population, the underlying diseases, and the acute disease itself necessitating invasive respiratory support that produce the vulnerability to nosocomial infection. The predominant organisms causing problems are gram-negative. Much later studies (including the definitive paper by Torres *et al* – related reference no. 3) confirmed these findings, and this is reflected in the recommendations from the CDC (related reference no. 6).

Title

A controlled trial of scheduled replacement of central venous and pulmonary-artery catheters

Author

Cobb DK, High KP, Sawyer RG, Sable CA, Adams RB, Lindley DA, Pruett TL, Schwenzler KJ, Farr BM

Reference

N Engl J Med 1992; **327**: 1062–1068

Abstract

The incidence of infection increases with the prolonged use of central vascular catheters, but it is unclear whether changing catheters every three days, as some recommend, will reduce the rate of infection. It is also unclear whether it is safer to change a catheter over a guide wire, or insert it at a new site. **METHODS.** We conducted a controlled trial in adult patients in intensive care units who required central venous or pulmonary-artery catheters for more than three days. Patients were assigned randomly to undergo one of four methods of catheter exchange: replacement every three days, either by insertion at a new site (group 1), or by exchange over a guide wire (group 2), or replacement when clinically indicated, either by insertion at a new site (group 3), or by exchange over a guide wire (group 4). **RESULTS.** Of the 160 patients, 5% had catheter-related bloodstream infections, 16% had catheters that became colonized, and 9% had major mechanical complications. The incidence rates (per 1000 days of catheter use) of bloodstream infection were 3 in group 1, 6 in group 2, 2 in group 3, and 3 in group 4; the incidence rates of mechanical complications were 14, 4, 8, and 3, respectively. Patients randomly assigned to guide-wire-assisted exchange were more likely to have bloodstream infection after the first three days of catheterization (6 percent vs. 0, $p = 0.06$). Insertions at new sites were associated with more mechanical complications (5 percent vs. 1 percent, $p = 0.005$). **CONCLUSIONS.** Routine replacement of central vascular catheters every three days does not prevent infection. Exchanging catheters with the use of a guide wire increases the risk of bloodstream infection, but replacement involving insertion of catheters at new sites increases the risk of mechanical complications.

Summary

A study was performed to try to determine when central venous catheters should be changed. There was no clear benefit from routine change at 3 days, but there was an increase in the mechanical complications of line changing.

Citation count

180

Related references

1. Maki DG, Weise CE, Sarafin HW. A semiquantitative culture method for identifying intravenous-catheter-related infection. *N Engl J Med* 1977; **296**: 1305–1309.
2. Collignon P, Soni N, Pearson I, Sorrell T, Woods P. Sepsis associated with central vein catheters in critically ill patients. *Intensive Care Med* 1988; **14**: 227–231.
3. Mermel LA, Farr BM, Sherertz RJ *et al.* Guidelines for the management of intravascular catheter-related infections. *Clin Infect Dis* 2001; **32**: 1249–1272.

4. Pearson ML. Guideline for prevention of intravascular device-related infections. The Hospital Infection Control Practices Advisory Committee. <http://www.cdc.gov/ncidod/hip/iv/iv.htm>.

Key message

- Routine catheter changes do not necessarily reduce infection risk.
- There may be an increased risk with guide wire exchanges.
- Replacement of catheters carries the morbidity of placement.

Why it's important

In preceding years, it seemed that every unit had its own protocol for catheter change based on the concept that regular replacement would reduce infection. The risk of line placement was considered to be either negligible or certainly to be outweighed by the infection risk. This paper addressed this irrefutable issue through a trial, and the results did not support popular practice. Similarly, the use of guide wires is frequently advocated, and this study opened the debate on its value and its safety. This was one of the first papers that provided a 'scientific' approach to a popular practice.

Strengths

The study addressed a very important question. This was a prospective randomized trial with four study groups identifying the main clinical methods in use at that time. The patients all had to have the catheters for >72 hours. There were 523 catheters in 160 patients, which was a large study for that period.

Weaknesses

The real study size. As there was a catheter-related infection rate of 2% of catheters, it was in effect a small study. There was a significant degree of heterogeneity within the study. Four study groups, and two types of catheter at two sites, subclavian and internal jugular. Both triple lumen catheters and pulmonary artery catheters were involved, when there may well be a fundamental difference between these devices in terms of colonization and infection.

Relevance

Catheter-related sepsis is a major iatrogenic problem with high morbidity and attributable mortality that is, at least in theory, preventable. With this study came an opportunity to reassess traditional clinical practice. The study asked three important questions, and the results suggested that the answers may well be different from conventional wisdom. It re-introduced changing devices on the basis of clinical indication, and it questioned the use of guide wires. Most importantly, it emphasized that placing these devices carries morbidity, and that this morbidity should be part of the equation of the cost benefit of line replacement.

Title

Serratia marcescens: historical perspective and clinical review

Author

Yu VL

Reference

N Engl J Med 1979; **300**: 887–893

Abstract

None

Summary

This is the story of a bug. The author describes, with some poetic license, its very long history, and its possible involvement in events in the ancient world right through to the present time. The paper describes how an organism of no known clinical significance has slowly emerged and become a recognized pathogen in critically ill patients. Indeed, it was used as a benign bacteriological marker in a range of scenarios, including students' practicals on bacterial dispersal. In more recent years, it has become increasingly recognized as a pathogen and as a cause of nosocomial infection. It has been implicated in plasmid-transferred resistance.

Citation count 183

Related references

1. Thomas FE, Jackson RT, Melly A, Alford RH. Sequential hospitalwide outbreaks of resistant *Serratia* and *Klebsiella* infections. *Arch Intern Med* 1977; **137**: 581–584.
2. Edmond MB, Wallace SE, McClish DK, Pfaller MA, Jones RN, Wenzel RP. Nosocomial bloodstream infections in United States hospitals: a three-year analysis. *Clin Infect Dis* 1999; **29**: 239–244.

Key message

The history of the evolution of an organism from a benign status to one of known multi-resistance is very clearly demarcated. Organisms are highly adaptable.

Why it's important

The reason for the inclusion of this paper is that for me, it is a real classic. It is a well-written rags to riches biography of a bug. It should be read by everyone dealing with the frustrations of multi-resistance in the ICU, not because the organism is particularly important in its own right, but because this biography may represent that of many organisms, both now and in the future. A similar story could be written for tuberculosis, as after several decades in apparent decline, it is resurgent and once again difficult to treat.

Strengths

Very well researched, well written, and an interesting read. It is entertaining, which is an unusual attribute for a medical paper.

Weaknesses

It is a review article. It does not change or challenge practice.

Relevance

There can be little doubt that we are entering an era where infectious disease is becoming a bigger problem. Multi-resistance and the use of antibiotics are becoming more problematic, rather than less. In any conflict, the key to success is to know the enemy, and after reading this biography, the reader will have more insight into at least one of the organisms that we currently have to deal with.

Title

A randomized trial comparing fluconazole with amphotericin B for the treatment of candidemia in patients without neutropenia: Candidemia Study Group and the National Institute

Author

Rex JH, Bennett JE, Sugar AM, Pappas PG, van der Horst CM, Edwards JE, Washburn RG, Scheld WM, Karchmer AW, Dine AP, Levenstein MJ, Webb CD

Reference

N Engl J Med 1994; **331**: 1325–1330

Abstract

BACKGROUND. Amphotericin B has long been the standard treatment for candidemia, but its use is complicated by its toxicity. More recently, fluconazole, a water-soluble triazole with activity against candida species and little toxicity, has become available. We conducted a multicenter randomized trial that compared amphotericin B with fluconazole as treatment for candidemia. **METHODS.** To be eligible, patients had to have a positive blood culture for candida species, a neutrophil count of 500 mm^3 , and no major immunodeficiency. Patients were randomly assigned to receive either amphotericin B (0.5 to 0.6 mg/kg/day) or fluconazole (400 mg per day), each continued for at least 14 days after the last positive blood culture. Outcomes were assessed by a group of investigators blinded to treatment assignment. **RESULTS.** Of the 237 patients enrolled, 206 met *et al* entry criteria. The most common diagnoses were renal failure, nonhematologic cancer, and gastrointestinal disease. There was no statistically significant difference in outcome: of the 103 patients treated with amphotericin B, 81 (79%) were judged to have been treated successfully, as were 72 of the 103 patients treated with fluconazole (70%; $p = 0.22$; 95% CI for the difference, -5 to 23 percent). The bloodstream infection failed to clear in 12 patients in the amphotericin group and 15 in the fluconazole group; the species most commonly associated with failure was *Candida albicans*. There were 41 deaths in the amphotericin group, and 34 deaths in the fluconazole group ($p = 0.20$). Intravascular catheters appeared to be the most frequent source of candidemia. There was less toxicity with fluconazole than with amphotericin B. **CONCLUSIONS.** In patients without neutropenia and without major immunodeficiency, fluconazole and amphotericin B are not significantly different in their effectiveness in treating candidemia.

Summary

A large study set out to compare the use of fluconazole with amphotericin B for treating candidemia in non-neutropenic patients. There was no obvious difference in efficacy, so fluconazole could be considered as equivalent for treatment.

Citation count 540

Related references

1. Rex JH, Walsh TJ, Sobel JD *et al*. Practice guidelines for the treatment of candidiasis. Infectious Diseases Society of America. *Clin Infect Dis* 2000; **30**: 662–678.
2. Stone HH, Kolb LD, Currie CA, Geheber CE, Cuzzell JZ. Candida sepsis: pathogenesis and principles of treatments. *Ann Surg* 1974; **179**: 697–711.

3. Solomkin JS, Flohr AM, Simmons RL. Indications for therapy for fungemia in postoperative patients. *Arch Surg* 1982; **117**: 1272–1275.
4. Pittet D, Monod M, Suter PM, Frenk E, Auckenthaler R. Candida colonization and subsequent infections in critically ill surgical patients. *Ann Surg* 1994; **220**: 751–758.
5. Eggimann P, Francioli P, Bille J *et al*. Fluconazole prophylaxis prevents intra-abdominal candidiasis in high-risk surgical patients. *Crit Care Med* 1999; **27**: 1066–1072.
6. Nguyen MH, Peacock JE Jr, Tanner DC *et al*. Therapeutic approaches in patients with candidemia. Evaluation in a multicenter, prospective, observational study. *Arch Intern Med* 1995; **155**: 2429–2435.

Key message

In non-neutropenic patients, candida sepsis can be as effectively treated with a less toxic alternative, fluconazole, as with amphotericin B.

Why it's important

At this time, candida was increasingly recognized as a potentially lethal problem in the critically ill patient. There were limited antifungal agents available, and amphotericin B was the recommended agent. Treatment was based largely on practice in the neutropenic patient who usually was not at risk of MOSF. The drug had a reputation for toxicity, and therefore there was reluctance to use it in a vulnerable population. This study changed all that. Associated with information about colonization preceding infection, and therefore the potential of earlier diagnosis, early intervention with a non-toxic agent was possible.

Strengths

A prospective randomized control trial in patients with a blood culture positive for candida. The treatment was based on confirmation of infection, and was not prophylactic or pre-emptive. It was carried out in non-neutropenic patients, a population that had been little studied previously. All except seven cases were infected with *C. albicans*. There is a recorded rate of endophthalmitis, which is a useful demographic finding. The complication rates with treatment in both groups were measured and were low.

Weaknesses

The outcome was surprisingly good in both groups of patients, with >70% survival. This is not consistent with the population of critically ill patients perceived to be at risk. It may be that as 72% of the cases were thought to be catheter-related, the study was really testing catheter-related candida sepsis. We know that catheter sepsis is likely to resolve on removal of the catheter, and that the mortality in catheter-related candidemia is said to be around 20% (related reference no. 6). The mortality rates in the remaining patients were not mentioned. The study also challenges the incidence of endophthalmitis in full-blown catheter sepsis. It does raise the question of definition of candida sepsis for future trials.

Relevance

From this study onward, it was possible to use agents other than amphotericin B. It demonstrated both the difficulties and the potential solutions in studies of candida sepsis. It effectively separated the management of the non-neutropenic patient from the rather strait-jacketed traditional prophylactic, pre-emptive, and presumptive treatment of neutropenic patients. From a time when there was a dearth of effective antifungal agents to the present, where there is an increasing array of potentially effective antifungal agents, it has set the scene for proper and effective evaluation of these agents in a relatively uncommon, but potentially lethal, condition.

Title

Viral hepatitis: a staff hazard in dialysis units

Author

Jones PO, Goldsmith HJ, Wright FK, Roberts C, Watson DC

Reference

Lancet 1967; **1**: 835–840

Abstract

None

Summary

This article was a detailed description of an outbreak of hepatitis in a dialysis unit affecting 18 members of staff and 4 patients. There had been previous reports of hepatitis from Edinburgh, Manchester, New York, and Stockholm. This paper examined the history of the outbreak in March 1966, when two technicians and two nurses became jaundiced. Then several patients and members of staff contracted hepatitis. Eventually 22 patients were infected, and although none died, this is very impressive morbidity. In the Manchester outbreak, there was a similar pattern, with 18 individuals infected, predominantly staff, but there were 4 deaths.

Various etiologies were proposed for the patients' infection, including blood transfusion, but it was clear that this did not apply to the staff. It was assumed that they contracted the disease from infected blood. On closer examination, there were patients in whom it was likely that the infection derived from contaminated equipment. 'Artificial kidneys were shared randomly.'

Citation count 82

Related references

1. Ross RS, Viazov S, Roggendorf M. Risk of hepatitis C transmission from infected medical staff to patients: model-based calculations for surgical settings. *Arch Intern Med* 2000; **160**: 2313–2316.
2. Marmion BP, Burrell CJ, Tonkin RW, Dickson J. Dialysis-associated hepatitis in Edinburgh; 1969–1978. *Rev Infect Dis* 1982; **4**: 619–637.
3. Ciesielski CA, Bell DM, Marianos DW. Transmission of HIV from infected health-care workers to patients. *AIDS* 1991; **5** (Suppl 2): S93–S97.

Key message

With technology comes the ability to transmit blood-borne infectious disease easily. It can spread from patients to staff, from staff to patients, and from staff to staff, although this message probably followed later. It was a new model of hospital transmission, an awareness of which has been integrated into hospital practice. It is relevant to other 'newer' diseases.

Strengths

It is a considered and unemotional account of the sequence of events that must have been devastating for those working there. It is a clear description of how the etiology and

method of spread were evaluated from the available information. It highlights the relative difficulty in differentiating between hepatitis A and B at that time. Conclusions based on flimsy evidence are well argued, and most have stood the test of time.

In one paragraph, the authors talk about staff illness putting work pressure on the remaining staff, and the resultant 'disorganization of duties', which sounds very similar to recent comments about hospital misadventure deriving from 'system failure'.

Weaknesses

It is, in essence, a case report. It is largely descriptive, and evidence is mainly circumstantial.

Relevance

Blood-borne infection is an ever-present hazard in critical care. The range of diseases known to be a problem has increased, and will almost certainly increase further as our knowledge base grows. Infection can spread wherever blood is involved, and can pass from patient to staff or vice versa. Prevention is through scrupulous prevention of contamination in all dealings with blood and blood products. There must be lessons here for considering new agents such as prions.

Title

Effectiveness of a hospital-wide programme to improve compliance with hand hygiene: Infection Control Programme

Author

Pittet D, Hugonnet S, Harbarth S, Mourouga P, Sauvan V, Touveneau S, Perneger TV

Reference

Lancet 2000; **356**: 1307–1312

Abstract

Hand hygiene prevents cross infection in hospitals, but compliance with recommended instructions is commonly poor. We attempted to promote hand hygiene by implementing a hospital-wide program, with special emphasis on bedside, alcohol-based hand disinfection. We measured nosocomial infections in parallel. METHODS: We monitored the overall compliance with hand hygiene during routine patient care in a teaching hospital in Geneva, Switzerland, before and during implementation of a hand hygiene campaign. Seven hospital-wide observational surveys were done twice yearly from December 1994 to December 1997. Secondary outcome measures were nosocomial infection rates, attack rates of methicillin-resistant *Staphylococcus aureus* (MRSA), and consumption of handrub disinfectant. FINDINGS: We observed more than 20,000 opportunities for hand hygiene. Compliance improved progressively, from 48% in 1994 to 66% in 1997 ($p < 0.001$). Although recourse to handwashing with soap and water remained stable, frequency of hand disinfection substantially increased during the study period ($p < 0.001$). This result was unchanged after adjustment for known risk factors of poor adherence. Hand hygiene improved significantly among nurses and nursing assistants, but remained poor among doctors. During the same period, overall nosocomial infection decreased (prevalence of 16.9% in 1994 to 9.9% in 1998; $p = 0.04$), MRSA transmission rates decreased (2.16 to 0.93 episodes per 10,000 patient-days; $p < 0.001$), and the consumption of alcohol-based handrub solution increased from 3.5 to 15.4 L per 1000 patient-days between 1993 and 1998 ($p < 0.001$). INTERPRETATION: The campaign produced a sustained improvement in compliance with hand hygiene, coinciding with a reduction of nosocomial infections and MRSA transmission. The promotion of bedside, antiseptic handrubs largely contributed to the increase in compliance.

Summary

Hand hygiene is notoriously poorly practiced in hospitals, despite its known association with cross-infection and subsequent morbidity. A hand hygiene campaign clearly improves hand hygiene, but compliance is enhanced by convenience measures such as hand disinfectants, for example, alcohol handrubs. The improvement in hand hygiene coincided with improvement in several markers of cross-infection.

Citation count

420

Related references

1. Daschner FD. How cost-effective is the present use of antiseptics? *J Hosp Infect* 1988; **11** (Suppl A): 227–235.
2. McNeil JJ, Proudfoot AD, Tosolini FA *et al*. Methicillin-resistant *Staphylococcus aureus* in an Australian teaching hospital. *J Hosp Infect* 1984; **5**: 18–28.

3. Farrington M, Ling J, Ling T, French GL. Outbreaks of infection with methicillin-resistant *Staphylococcus aureus* on neonatal and burns units of a new hospital. *Epidemiol Infect* 1990; **105**: 215–228.

Key message

Handwashing is the single most important infection control measure. It is cheap and cost effective. The main problem with it is compliance, and this can be improved by convenience measures such as bedside antiseptic handrubs.

Why it's important

Nosocomial infection is a major source of morbidity and mortality in the critically ill. Frequently, infection is spread by staff within the critical care environment. It is a completely avoidable problem that can be addressed by relatively simple measures.

Strengths

A large observational study focused on a simple problem. Performed by trained personnel. It reinforces what we all know.

Weaknesses

This was not a randomized trial. It looked at several components of infection control across a wide range of locations. It was based on a series of surveys. The role of the study in terms of improving compliance is impossible to assess.

Relevance

This study highlights the importance of handwashing in the prevention of cross-infection. It is clearly not the only important part of prevention, but it is a fundamental part of any approach to infection control. The paper highlights the relatively poor compliance, even after all their efforts, if one considers that this should be universal hygienic practice. Their results may well be the better end of the spectrum across hospitals, and the study indicates that it is an area for attention to detail.

In an era of complex science and technology, it is remarkable how much can be achieved by recourse to fundamental practices.

Vasoactive and cardiotonic drugs

Jean-Louis Vincent

Introduction

Vasoactive drugs are probably, alongside the antibiotic, the most commonly used drugs on the intensive care unit (ICU). Indeed, the majority of ICU patients will receive one or other vasoactive agent during their ICU stay. While not so long ago, adrenergic support was administered merely to restore blood pressure and support cardiac contractility, recent evidence has suggested possible additional roles for adrenergic agents. Adequate global perfusion and oxygenation are essential aims of resuscitation, but in recent years, the importance of regional perfusion has also been realized. The hepatosplanchnic area, in particular, has been targeted, as hypoxia in this area may be associated with the development of multiple organ failure. Many experimental and clinical studies have been conducted in an attempt to determine which, if any, of the available vasoactive agents has a specific action on enhancing regional blood flow and oxygenation. In addition, recent studies suggest that adrenergic agents may also have some anti-inflammatory effects, which may change the way in which these agents are selected and used in the treatment of septic shock, and other disease processes with an inflammatory component, such as pancreatitis, trauma, or major surgery.

In selecting the following papers, I have tried to highlight some of the key steps in the history of vasoactive agents in the ICU, moving from an early study with dopamine that changed practice at that time, and led to the almost routine, widespread use of low-dose 'renal' dopamine, a practice that has now been abandoned, to a study investigating the regional effects of dopexamine, a relative newcomer whose exact place in our vasoactive armamentarium is, as yet, undefined.

Title

Sodium diuresis produced by dopamine in patients with congestive heart failure

Author

Goldberg LI, McDonald RH, Zimmerman AM

Reference

N Engl J Med 1963; **269**: 1060–1064

Abstract

Not available

Summary

This paper is, in essence, a quadruple case report of patients with severe congestive heart failure who responded to a dopamine infusion by increasing urine output and sodium excretion. The patients were a 47-year-old man with a 4 year history of hypertensive cardiac disease, diabetes mellitus, and congestive heart failure uncontrolled on trichlormethiazide, mercaptopimerin, digoxin, and a low-salt diet; a 59-year-old man with a 6 month history of progressive congestive heart failure treated with digoxin, aminophylline, lysine hydrochloride, hydrochlorothiazide, and spironolactone; a 48-year-old diabetic man with a 6 month history of congestive cardiac failure well controlled on digoxin, diuretics, and salt restriction, but who developed pulmonary edema following a large fluid infusion for presumed dehydration; and a 56-year-old woman with a 15 year history of congestive heart failure not controlled on digoxin, trichlormethiazide, and mercaptopimerin.

Dopamine infusion, at doses ranging from 65 to 1200 µg/min, increased blood pressure and heart rate in all patients. It also increased urine output and sodium excretion in all four patients, and potassium excretion in three of the patients.

Citation count 149

Related references

1. McDonald RH, Goldberg LI, McNay JL *et al.* Effects of dopamine in man: augmentation of sodium excretion, glomerular filtration rate and renal plasma flow. *J Clin Invest* 1964; **43**: 1116–1124.
2. Vincent JL. Renal effects of dopamine: can our dream ever come true? *Crit Care Med* 1994; **22**: 5–6.
3. Australian and New Zealand Intensive Care Society (ANZICS) Clinical Trials Group. Low-dose dopamine in patients with early renal dysfunction: a placebo-controlled randomised trial. *Lancet* 2000; **356**: 2139–2141.

Key message

The intravenous administration of dopamine in patients with cardiac failure can increase urine output and sodium excretion, and hence be of use in the treatment of heart failure.

Why it's important

This is one of the first published papers describing the use of dopamine in a clinical situation. The increased urine output reported in this and other studies in animals and human volunteers provided evidence that low-dose dopamine infusions could augment water and sodium excretion, and the use of low-dose ('renal-dose') dopamine infusions in critically ill patients became established as virtually routine practice.

Strengths

First clinical report of a potentially beneficial intervention.

Weaknesses

As a case report study, this paper is purely descriptive, and as such provides no reliable information on the effectiveness and safety of dopamine, except in these four patients. In addition, no cardiac output data are given, so it is difficult to separate the specific renal effects from the global hemodynamic effects. Low doses of dopamine do stimulate the beta-receptors, and the observed effects may have been due to an increase in cardiac output.

Relevance

This paper is relevant to current medical practice because it provides early support for the beneficial effects of dopamine in a select group of patients. The concept of 'renal-dose' dopamine has produced considerable debate and controversy over the years. With the lack of convincing evidence for a beneficial effect in acutely ill patients, it has now largely been abandoned, especially after the recent randomized trial from Australasia which reported no beneficial renal effects of low-dose dopamine.

Title

Clinical cardiovascular pharmacology of dobutamine: a selective inotropic catecholamine

Author

Jewitt D, Birkhead J, Mitchell A, Dollery C

Reference

Lancet 1974; **2**: 363–367

Abstract

Not available

Summary

Two studies are reported in this paper: (1) a so-called phonocardiographic study in seven patients with aortic valve prostheses; the patients received dobutamine (2.5, 5, 10 µg/kg/min) or isoprenaline (0.02, 0.04, 0.08 µg/kg/min), in random order, and on separate days for 10 minutes (2) a hemodynamic study in 10 patients with congestive cardiomyopathy or coronary artery disease undergoing cardiac catheterization. The patients received infusions of dobutamine at concentrations of 2.5, 5 and 10 µg/kg/min, separated by 10-minute control periods.

In the phonocardiographic study, both drugs produced comparable changes in left ventricular ejection and blood pressure, but isoprenaline increased the heart rate to a greater extent than dobutamine. In the hemodynamic study, dobutamine was associated with a dose-related increase in cardiac output and stroke volume, and a decrease in total peripheral resistance and in the arteriovenous oxygen saturation difference. Oxygen consumption increased with the two higher doses. No side effects were noted with dobutamine in either study.

Citation count 130

Related references

1. Worthley LI, Tyler P, Moran JL. A comparison of dopamine, dobutamine and isoproterenol in the treatment of shock. *Intensive Care Med* 1985; **11**: 13–19.
2. Pinaud M, Desjars P, Nicolas F. Dobutamine in the treatment of depressed cardiac function: a study in patients with ischaemic heart disease during the early post-operative period. *Intensive Care Med* 1978; **4**: 105–110.

Key message

Dobutamine produced a dose-related increase in cardiac performance without significant increase in heart rate, and thus should be of use in the treatment of cardiovascular failure associated with a low cardiac output.

Why it's important

This is an early study highlighting the potential beneficial inotropic effects of dobutamine, a drug that has gone on to become the recommended inotrope in the management of heart failure and circulatory shock. Before the development of dobutamine, isoprenaline was indeed the inotropic agent of choice but its use was limited by tachycardia, particularly at higher doses. As shown in this study, dobutamine administration is associated with comparable hemodynamic effects, but with a lesser increase in heart rate.

Strengths

The study assessed various doses of dobutamine in the same patients, who thus acted as their own controls.

Weaknesses

Descriptive study. In the phonocardiographic study, infusions of dobutamine and isoprenaline were given on different days when, potentially, the baseline cardiovascular status of the patients was different.

Relevance

This paper is relevant to modern practice because it describes an early study of the hemodynamic effects of dobutamine, at that time a new and relatively clinically untested inotropic drug. Since then, dobutamine has been widely studied, and is now the recommended inotrope of reference not only in the management of heart failure, but also in acute circulatory failure (shock).

Title

Comparative systemic and regional hemodynamic effects of dopamine and dobutamine in patients with cardiomyopathic heart failure

Author

Leier CV, Heban PT, Huss P, Bush CA, Lewis RP

Reference

Circulation 1978; **58**: 466–475

Abstract

Thirteen patients with severe cardiac failure underwent a single crossover study of dopamine and dobutamine in order to compare the systemic and regional hemodynamic effects of the two drugs. The dose-response data demonstrated that dobutamine (2.5–10 mg/kg/min) progressively and predictably increases cardiac output by increasing stroke volume, while simultaneously decreasing systemic and pulmonary vascular resistance and pulmonary capillary wedge pressure. There was no change in heart rate or premature ventricular contractions (PVCs)/min at this dose range. Dopamine (2–8 mg/kg/min) increased the stroke volume and cardiac output at 4 mg/kg/min. Dopamine at less than 4 mg/kg/min provided little additional increase in cardiac output, and increased the pulmonary wedge pressure and the number of PVCs/min. At greater than 6 mg/kg/min, dopamine increased heart rate. During the 24-hour maintenance-dose infusion of each drug (dopamine 3.7–4, dobutamine 7.3–7.7 mg/kg/min), only dobutamine maintained a significant increase of stroke volume, cardiac output, urine flow, urine sodium concentration, creatinine clearance, and peripheral blood flow. Renal and hepatic blood flow were not significantly altered by the maintenance dose of either drug. Systemic and regional hemodynamic data suggest that dobutamine has many advantages over dopamine when infused in patients with cardiac failure.

Summary

Thirteen patients with left ventricular failure due to a congestive cardiomyopathy were administered intravenous infusions of dopamine (max dose 8 µg/kg/min) and dobutamine (max dose 10 µg/kg/min) in a cross-over design. Systemic and regional hemodynamic data were obtained during a dose-response study and a 24-hour period of continuous maintenance infusion (dopamine 3.7–4.0 µg/kg/min, dobutamine 7.3–7.7 µg/kg/min). Dobutamine increased cardiac index in a dose-dependent fashion, with no change in heart rate, while dopamine increased cardiac index only at higher doses, and there was an associated increase in heart rate. Dopamine also increased pulmonary capillary wedge pressure, systemic, and pulmonary resistance, while dobutamine decreased these variables. During the 24-hour infusion, only dobutamine maintained a significant increase in stroke volume, cardiac output, urine flow, urine sodium excretion, creatinine clearance, and peripheral blood flow.

Citation count

226

Related references

1. Loeb HS, Bredakis J, Gunnar RM. Superiority of dobutamine over dopamine for augmentation of cardiac output in patients with chronic low output cardiac failure. *Circulation* 1977; **55**: 375–378.
2. Stoner JO III, Bolen JL, Harrison DC. Comparison of dobutamine and dopamine in treatment of severe heart failure. *Br Heart J* 1977; **39**: 536–539.
3. Leier CV, Unverferth DV. Drugs five years later. Dobutamine. *Ann Intern Med* 1983; **99**: 490–496.

Key message

Dobutamine is a superior inotrope to dopamine in the treatment of low output congestive cardiomyopathy.

Why it's important

The study illustrates well the differences between dopamine and dobutamine. Dobutamine is now widely considered to be the inotrope of choice in patients with cardiovascular shock.

Strengths

Cross-over design. Effects of prolonged infusion were assessed in addition to short-term bolus effects.

Weaknesses

Small number of patients studied. This is a relatively global study, and provides little information about the mechanisms involved.

Relevance

This study is relevant because it provides an important comparison of two catecholamine agents. While members of the same group of drugs, the effects of these two agents are critically dependent on the receptors that they influence. Dobutamine is a more potent inotropic agent than dopamine, which has a stronger vasopressor effect. Both are therefore of use in the critically ill, but for different indications. It is important that clinicians are aware of the differences, and are able to utilize both drugs correctly to their full benefit.

Title

A comparison of digoxin and dobutamine in patients with acute infarction and cardiac failure

Author

Goldstein RA, Passamani ER, Roberts R

Reference

N Engl J Med 1980; **303**: 846–850

Abstract

The hemodynamic effects of dobutamine were compared with those of digoxin in six patients with cardiac failure within 24 hours of onset of acute myocardial infarction. Dobutamine (8.5 mg/kg/min) was given intravenously for 30 minutes, and then discontinued until hemodynamics returned toward baseline. Digoxin (12.5 mg/kg) was then given intravenously, and hemodynamics were recorded for 90 minutes. Dobutamine decreased left ventricular filling pressure (from 22.3 to 9.8 mmHg, $p < 0.02$) and systemic vascular resistance (1686 +/- 188 to 1259 +/- 108 dynes . sec . cm⁻⁵), and increased cardiac index (from 2.4 to 3.2 L/min/m² of body-surface area, $p < 0.005$), and stroke work index (from 24.6 to 36.6 g . m per square meter, $p < 0.02$), without changing heart rate or arterial pressure. In contrast, digoxin had no effect on filling pressure (18.3 versus 17.0), and only a slight effect on cardiac index (2.2 versus 2.4, $p < 0.05$) and stroke work index (21.9 versus 27.6, $p < 0.05$). Thus, dobutamine markedly increased cardiac output, decreased filling pressure, and relieved pulmonary congestion. Digoxin did not affect preload or afterload.

Summary

The hemodynamic effects of digoxin and dobutamine were compared in six patients with cardiac failure within 24 hours of myocardial infarction. Dobutamine (mean 8.5 µg/kg/min) was given for 30 minutes, and then discontinued to allow hemodynamic measurements to return to normal. Digoxin (12.5 µg/kg) was then administered. Dobutamine decreased left ventricular filling pressure and systemic vascular resistance, and increased cardiac index and stroke work index, without changing heart rate or arterial pressure, while digoxin had no effect on filling pressures, and a lesser effect on stroke work index and cardiac index.

Citation count 108

Related references

1. Gillespie TA, Ambos HD, Sobel BE *et al.* Effects of dobutamine in patients with acute myocardial infarction. *Am J Cardiol* 1975; **39**: 588–594.

Key message

Dobutamine is superior to digoxin in the treatment of patients with acute myocardial infarction and heart failure.

Why it's important

Digoxin was for many years a standard part of the treatment of patients with cardiac failure. However, with its slow onset of action and its long half-life, it was by no means ideal. The development of dobutamine, which was clearly shown to be more effective and efficient in patients with cardiac failure, and had a rapid action and a half-life of just 2–3 minutes, led to a fall in the use of digoxin for this indication.

Strengths

Well-designed study to determine the place of dobutamine in the management of heart failure.

Weaknesses

Small number of patients. The effects of dobutamine were only assessed during short-term administration (30 minutes), and only in normotensive patients.

Relevance

For many years, digoxin was widely used in the treatment of heart failure. However, studies such as this indicated that it was, in fact, a weak inotrope, and other drugs were more effective and easier to administer. It is now much less widely used, and reserved for specific indications, including atrial fibrillation. This paper is thus largely of historic interest, although without such studies, we would have made no advances in clinical therapeutic practice.

Title

Dobutamine therapy in acute myocardial infarction

Author

Keung ECH, Siskind SJ, Sonneblich EH, Ribner HS, Schwartz WJ, LeJemtel TH

Reference

JAMA 1981; **245**: 144–146

Abstract

The short-term response of combined dopamine hydrochloride-sodium nitroprusside therapy was compared with administration of dobutamine in eight patients with acute myocardial infarction complicated by hypotension and severe left ventricular dysfunction. All patients were receiving dopamine before the study began. The addition of sodium nitroprusside increased cardiac index (CI) from 1.94 +/- 0.490 to 2.22 +/- 0.48 L/min/sq m; decreased left ventricular filling pressure (LVFP) from 28.9 +/- 3.5 to 19.9 +/- 3.3 mmHg and mean systemic arterial pressure (MAP) from 82.1 +/- 5.1 to 71.5 +/- 6.0 mmHg. During dobutamine infusion, CI, LVFP, and MAP were 2.33 +/- 0.31 L/min/sq m, 20.8 +/- 4.8 mmHg, and 74.1 +/- 8.1 mmHg, respectively. There was no statistical difference between short-term hemodynamic benefits produced by dobutamine or combined dopamine-sodium nitroprusside therapy. Dobutamine, a synthetic catecholamine, provides a substitute for dopamine-sodium nitroprusside therapy in acute myocardial infarction. Dobutamine has the advantage of being a single agent, and is therefore easier to administer.

Summary

Eight patients with left ventricular failure and hypotension due to myocardial infarction and treated with dopamine (mean dose 9.1 µg/kg/min) were given an infusion of sodium nitroprusside (mean 1.2 µg/kg/min) for 45 minutes, and hemodynamic parameters were monitored. The sodium nitroprusside was then discontinued, and the hemodynamic variables were allowed to return to pre-nitroprusside values. Dopamine was then also discontinued, and a dobutamine infusion administered at increasing doses until the same hemodynamic status was achieved as with dopamine and nitroprusside. The addition of sodium nitroprusside to dopamine decreased left ventricular filling pressures and increased cardiac index. Mean arterial pressure and systemic vascular resistance also decreased. The dobutamine infusion decreased left ventricular filling pressures, and increased cardiac index to a similar degree as with the dopamine-nitroprusside combination.

Citation count 39

Related references

None

Key message

Dobutamine has the same beneficial effects on left ventricular filling pressures while restoring arterial pressure and cardiac index, as the combination of dopamine with sodium nitroprusside. Its advantage is that, as a single agent, it is easier to administer.

Why it's important

This study documents the hemodynamic effects of dobutamine as being quite similar to the combination of dopamine (increases cardiac output and arterial pressure) and nitroprusside (increases cardiac output, but tends to decrease arterial pressure); indeed, dobutamine increases cardiac output significantly with little effect on arterial pressure.

Strengths

Acute, cross-over study.

Weaknesses

Small number of patients, and only the effects of short-term infusions of the drugs were compared.

Relevance

This study is relevant to modern clinical practice, as it helps to define the exact position of dobutamine in the therapeutic armamentarium. Dopamine increases myocardial contractility by its effects on β_1 -adrenoceptors, and at doses above 5 $\mu\text{g}/\text{kg}/\text{min}$ increases blood pressure by its α_1 vasoconstricting effects. However, at these doses, it also increases ventricular filling pressures, thus having potentially negative effects on cardiac function and myocardial oxygen consumption. Dobutamine affects predominantly β_1 -adrenergic receptors, with minimal β_2 - and α_1 -effects. As such, it increases cardiac output with limited effect on blood pressure. Its effect on left ventricular filling pressures is an additional benefit, and it is the inotrope of choice in patients with cardiovascular shock.

Title

Hemodynamic and oxygen transport effects of dobutamine in critically ill general surgical patients

Author

Shoemaker WC, Appel PL, Kram HB

Reference

Crit Care Med 1986; **14**: 1032–1037

Abstract

The effects of dobutamine on hemodynamic and oxygen transport were evaluated in 43 studies on 34 critically ill, general (noncardiac) surgical patients. Dobutamine, beginning at a low dose (2.5 mg/kg/min) significantly increased cardiac index (CI), oxygen delivery (DO_2), and oxygen consumption (VO_2), while decreasing mean arterial pressure, pulmonary artery and wedge pressures, and systemic and pulmonary vascular resistances; blood gases, pH, and pulmonary shunt were not significantly changed. These effects were seen in postoperative and septic patients, as well as in patients with normal, low, and high control CI. These responses were poor in terminally ill and hypovolemic patients; however, when the latter were given additional fluids, their responses were markedly improved. The hemodynamic effects of dobutamine are well known, but the DO_2 and VO_2 effects, which suggest improved tissue perfusion, have not been appreciated.

Summary

Thirty-four critically ill, general surgical patients were administered increasing doses of dobutamine, from 2.5 to 10 $\mu\text{g}/\text{kg}/\text{min}$. Dobutamine increased cardiac index, stroke work index, oxygen delivery and consumption, and heart rate, and decreased mean arterial pressure, mean pulmonary artery pressure, wedge pressure, and central venous pressure. The data were then analyzed according to the baseline cardiac index, and the authors noted that the effects of dobutamine were similar regardless of the baseline cardiac index.

Citation count

68

Related references

1. Vincent JL, Roman A, Kahn RJ. Dobutamine administration in septic shock: addition to a standard protocol. *Crit Care Med* 1990; **18**: 689–693.
2. Gutterrez G, Clark C, Brown SD *et al*. Effects of dobutamine on oxygen consumption and gastric mucosal pH in septic patients. *Am J Respir Crit Care Med* 1994; **150**: 324–329.
3. De Backer D, Moraine JJ, Berré J *et al*. Effects of dobutamine on oxygen consumption in septic patients. *Am J Respir Crit Care Med* 1994; **150**: 95–100.

Key message

Dobutamine has beneficial effects on hemodynamic and oxygenation parameters in patients with shock, regardless of the cardiac output.

Why it's important

This was the first paper to demonstrate potentially beneficial effects of dobutamine on oxygenation parameters, and hence on tissue perfusion. Oxygen transport deficiencies are known to be associated with a worse outcome, and hence, in addition to improving hemodynamic status, dobutamine provides added benefit by improving oxygenation.

Strengths

Dobutamine was known to have beneficial hemodynamic effects in patients with low-flow states; a strong point of this study was that the effects of dobutamine were also assessed in patients with normal or high cardiac outputs.

Weaknesses

The information provided is relatively limited.

Relevance

Since this study, dobutamine has been used extensively to increase cardiac output and oxygen transport in patients with acute circulatory failure. While this paper only considered global oxygenation parameters, recent interest has focused on the specific effects of adrenergic agents on regional tissue perfusion and oxygenation. Among the adrenergic agents, dobutamine seems most consistently to increase regional flow, but this is related to the systemic effects noted already by Shoemaker *et al.*, and not to any local effect.

Title

Oxygen uptake/supply dependency: effects of short-term dobutamine infusion

Author

Vincent JL, Romain A, De Backer D, Khan RJ

Reference

Am Rev Respir Dis 1990; **142**: 2–7

Abstract

The present study explored the possibility of using a short-term dobutamine infusion to disclose oxygen uptake/supply dependency. The effects of a standard dose of 5 mg/kg/min of dobutamine on oxygen-derived variables were studied in 73 acutely ill patients with heart failure (n = 24) or sepsis (n = 49). In each group, patients were separated according to their blood lactate concentrations (either above or below 2 mEq/L). In all patient groups, dobutamine resulted in significant increases in cardiac output and oxygen transport. However, oxygen consumption increased significantly only in patients with elevated blood lactate levels (cardiac failure: from 108 +/- 26 to 131 +/- 25 ml/min/m², n = 8, p < 0.01; sepsis: from 139 +/- 44 to 167 +/- 68 ml/min/m², n = 16, p < 0.01), and not in the other patients (heart failure: from 121 +/- 29 to 115 +/- 31 ml/min/m², n = 28, NS; sepsis: from 158 +/- 39 to 166 +/- 45 ml/min/m², n = 21, NS). These data, therefore, indicate that dobutamine at the dose used does not increase oxygen consumption in critically ill patients unless there is coexistent tissue hypoxia reflected by increased blood lactate levels. A short-term dobutamine infusion can be used to disclose an oxygen uptake/supply dependency phenomenon.

Summary

The effects of a 30-minute infusion of 5 µg/kg/min dobutamine were studied in 73 acutely ill patients with heart failure (24 patients) or sepsis (49 patients). Dobutamine increased cardiac output and oxygen transport in all patients, but oxygen consumption was increased only in patients with high blood lactate levels (> 2 mEq/L).

Citation count 153

Related references

1. Bihari D, Smithies M, Gimson A *et al.* The effects of vasodilation with prostacyclin on oxygen delivery and uptake in critically ill patients. *N Engl J Med* 1987; **317**: 397–403.
2. De Backer D, Creteur J, Noordally O *et al.* Does hepato-splanchnic VO₂/DO₂ dependency exist in critically ill septic patients? *Am J Respir Crit Care Med* 1998; **157**: 1219–1225.

Key message

Dobutamine only increases oxygen uptake significantly in patients with an underlying tissue oxygen deficit as indicated by raised blood lactate levels. A short-term dobutamine infusion can disclose the presence of this oxygen uptake/supply dependency.

Why it's important

Oxygen uptake remains relatively constant in normal conditions because oxygen extraction capabilities are able to increase to counteract any fall in oxygen delivery. However, when oxygen supply falls below a critical level, compensatory mechanisms are no longer adequate, and oxygen uptake becomes supply-dependent. In some critically ill patients, oxygen uptake/supply dependency can occur at higher levels of oxygen supply. This phenomenon is associated with increased mortality, and therefore its early identification could have important clinical consequences, allowing treatment to be appropriately targeted.

Strengths

This approach has changed the concepts of circulatory shock, shifting the emphasis from just arterial hypotension to inadequate blood flow and tissue oxygen delivery. This, in turn, has resulted in changes in the management of circulatory shock, as clinicians now administer dobutamine to increase cardiac output in shock to further enhance oxygen availability, even when cardiac output is normal or high.

Weaknesses

The benefit of this strategy has not been proven clinically; measurements are difficult, and plotting oxygen consumption (VO_2) against oxygen delivery (DO_2) may lead to mathematical coupling of data. Direct determination of VO_2 from expired gas analysis (indirect calorimetry) is time-consuming, and still limited by difficulties in defining optimal values. Hence, these concepts cannot be used to guide therapy in practice.

Relevance

Although dobutamine should not be administered routinely in critically ill patients, it can help to increase cell oxygen availability in acute circulatory failure, and is safe and well tolerated.

Title

Prognostic value of the dobutamine test in patients with sepsis syndrome and normal lactate values: a prospective, multicenter study

Author

Vallet B, Chopin C, Curtis SE, Dupuis BA, Fourrier F, Mehdaoui H, LeRoy B, Rime A, Santre C, Herbecq P, Her B

Reference

Crit Care Med 1993; **21**: 1868–1875

Abstract

OBJECTIVES: To determine the oxygen supply (DO_2) and uptake (VO_2) responses to a 60-minute dobutamine infusion in critically ill, septic patients without circulatory shock and with normal blood lactate concentrations. Also, to determine whether these responses would predict outcome. **DESIGN:** Prospective, cohort study. **SETTING:** Five intensive care units in university-affiliated, city hospitals. **PATIENTS:** Fifty critically ill patients with sepsis syndrome were studied from April 1990 to August 1991. **INTERVENTIONS:** Pulmonary artery catheterization; fluid loading if pulmonary artery occlusion pressure was < 10 mm Hg; and 10 mg/min/kg dobutamine infusion for 60 minutes. **MEASUREMENTS AND MAIN RESULTS:** Cardiac index, DO_2 , VO_2 , and oxygen extraction ratio were determined immediately before and 1 hour after the onset of the dobutamine test. Using receiver operating characteristic curves, responders to the dobutamine infusion were identified by a $> 15\%$ increase in VO_2 from the time immediately before to 1 hour after the onset of the dobutamine test. We identified 23 responders and 27 nonresponders. Groups differed significantly in age (responders 46 yrs vs. nonresponders 55 yrs), and associated chronic disease (responders one cancer vs. nonresponders six cancers). Significant changes in responders: a) cardiac index increased 42.9%; b) systemic vascular resistance decreased 20.7%; and c) DO_2 increased 39.1% while VO_2 increased 40.8%, with no changes in oxygen extraction or blood lactate concentration. Significant changes in nonresponders were: a) cardiac index increased 14.2%; b) DO_2 increased 13.2%, and c) oxygen extraction decreased from 0.26 to 0.22. Lactate concentration increased significantly by 25.1% in nonresponders. The mortality rate in responders (8.7%) was significantly less than that rate in nonresponders (44.4%). **CONCLUSIONS:** Most of these septic patients without shock or hyperlactatemia responded to dobutamine infusion in one of two ways: with little increase in DO_2 and no increase in VO_2 , or with significant increases in both DO_2 and VO_2 . The latter response is typical of healthy volunteers given dobutamine. Because of the calorogenic effect of dobutamine, our results imply nothing about the presence or absence of oxygen supply limitation. Still, patients who had increases in DO_2 and VO_2 had a much higher survival rate than patients who did not. We speculate that the inability of some patients to respond to dobutamine, and the associated higher mortality rate, may be related to beta-adrenoreceptor dysfunction.

Summary

Fifty hemodynamically stable patients with sepsis syndrome were given a 1-hour infusion of 10 μ g/kg/min dobutamine, and hemodynamic and oxygenation parameters were monitored. Cardiac index and oxygen delivery increased in all patients, but the increase in

oxygen delivery was significantly greater in the survivors. Oxygen uptake increased significantly only in survivors. The authors determined a cut-off point for increased oxygen uptake of 15%, and defined those patients with an increase in oxygen uptake > 15% as dobutamine test responders. Of the 50 patients, 23 were responders and 27 non-responders. There were no significant differences in hemodynamic or metabolic variables in the two groups before the test. The responders had a significantly lower mortality rate (9%) than the non-responders (44%).

Citation count 48

Related references

1. Rhodes A, Lamb FJ, Malagon I *et al.* A prospective study of the use of a dobutamine stress test to identify outcome in patients with sepsis, severe sepsis, or septic shock. *Crit Care Med* 1999; **27**: 2361–2366.

Key message

Patients with sepsis who are unable to increase oxygen uptake by > 15% during a dobutamine infusion have a poor prognosis.

Why it's important

The normal response to a dobutamine infusion is an increase in both oxygen uptake and delivery. The ability of patients to produce a 'normal' response is predictive of a good outcome. Inability to respond is probably associated with an inadequate cellular response related to adrenergic hyporesponsiveness.

Strengths

This study illustrates that the response to the stimulation of adrenergic receptors can be significantly altered in critical conditions, due to down-regulation of the receptors involved.

Weaknesses

One could argue that this phenomenon is borne out by clinical evidence, and there are many other studies where down-regulation of adrenergic receptors is demonstrated.

Relevance

Adrenergic hyporesponsiveness is unpredictable. It is, therefore, difficult to define a 'correct' dose for all patients, and the response to adrenergic agents must be monitored and tailored to the individual patient.

Title

Norepinephrine or dopamine for the treatment of hyperdynamic septic shock?

Author

Martin C, Papazian L, Perrin G, Saux P, Gouin F

Reference

Chest 1993; **103**: 1826–1831

Abstract

STUDY OBJECTIVE: To compare the ability of dopamine and norepinephrine to reverse hemodynamic and metabolic abnormalities of human hyperdynamic septic shock. DESIGN: Prospective, double-blind, randomized trial. SETTING: An ICU in a university hospital. PATIENTS: Adult patients with hyperdynamic septic shock after fluid resuscitation. INTERVENTIONS: Patients were assigned to receive either dopamine (2.5 to 25 mg/kg/min) or norepinephrine (0.5 to 5.0 mg/kg/min). If hemodynamic and metabolic abnormalities were not corrected with the maximum dose of one drug, the other was added. MEASUREMENTS AND RESULTS: The aim of therapy was to achieve and maintain for at least 6 hours all of the following: (1) systemic vascular resistance index $> 1,100$ dynes. \cdot s/cm⁵.m² and/or mean systemic blood pressure ≥ 80 mm Hg; (2) cardiac index ≥ 4.0 L/min/m²; (3) oxygen delivery > 550 ml/min/m²; and (4) oxygen uptake > 150 ml/min/m². With the use of dopamine at 10 to 25 mg/kg/min, 5 of 16 patients (31 percent) were successfully treated, as compared with 15 of 16 patients (93 percent) by norepinephrine at a dose of 1.5 ± 1.2 mg/kg/min ($p < 0.001$). Ten of 11 patients who did not respond to dopamine and remained hypotensive and oliguric were successfully treated with the addition of norepinephrine. CONCLUSIONS: At the doses tested, norepinephrine was found, in the present study, to be more effective and reliable than dopamine to reverse the abnormalities of hyperdynamic septic shock. In the great majority of the study patients, norepinephrine was able to increase mean perfusing pressure without apparent adverse effect on peripheral blood flow or on renal blood flow (since urine flow was reestablished). At the same time, oxygen uptake was increased.

Summary

Thirty-two patients with hyperdynamic septic shock were randomized to receive either dopamine (2.5–25 μ g/kg/min) or norepinephrine (0.5–5 μ g/kg/min) after fluid resuscitation. If an adequate hemodynamic status was not achieved with either agent alone, the other was added. Five of the dopamine patients (33%) achieved the desired hemodynamic targets, compared with 15 of the norepinephrine patients (93%). Ten of the 11 patients who did not respond to dopamine were successfully treated with norepinephrine. Norepinephrine had no adverse effects on peripheral blood flow, and indeed restored urine output in oliguric patients.

Citation count 147

Related references

1. Martin C, Viviand X, Leone M *et al*. Effect of norepinephrine on the outcome of septic shock. *Crit Care Med* 2000; **28**: 2758–2765.
2. Zhang H, Smail N, Cabral A, Rogiers P, Vincent JL. Effects of norepinephrine on regional blood flow and oxygen extraction capabilities during endotoxic shock. *Am J Respir Crit Care Med* 1997; **155**: 1965–1971.

Key message

Norepinephrine can be more efficient and reliable than dopamine in reversing the hemodynamic abnormalities seen in septic shock.

Why it's important

Dopamine is classically the vasopressor of choice for the restoration of tissue perfusion pressure in shock. This study suggests that in patients with sepsis, norepinephrine may be a better first choice to rapidly restore arterial pressure.

Strengths

Randomized, controlled, double-blind trial.

Weaknesses

Small patient numbers – end-points (arterial pressure) not necessarily very relevant.

Relevance

The 'best' adrenergic support in the treatment of septic shock remains controversial. Norepinephrine is a strong vasopressor and can increase arterial pressure more consistently than dopamine, but carries a risk of peripheral vasoconstriction associated with insufficient flow. The concurrent administration of dobutamine is usually recommended to avoid this problem.

Title***Elevation of systemic oxygen delivery in the treatment of critically ill patients***

Author

Hayes MA, Timmins AC, Yau EHS, Palazzo M, Hinds CJ, Watson D

Reference*N Engl J Med* 1994; **330**: 1717–1722

Abstract

BACKGROUND. Elevation of systemic oxygen delivery and consumption has been associated with an improved outcome in critically ill patients. We conducted a randomized trial to determine whether boosting oxygen delivery by infusing the inotropic agent dobutamine would improve the outcome in a diverse group of such patients. METHODS. On the basis of previously published recommendations, we established the following goals: a cardiac index above 4.5 L/min/m² of body-surface area, oxygen delivery above 600 ml/min/m², and oxygen consumption above 170 ml/min/m². If these goals were not achieved with volume expansion alone, patients were randomly assigned to a treatment or control group. The treatment group received intravenous dobutamine (5 to 200 mg/kg/min) until all three goals had been achieved. Dobutamine was administered to the control group only if the cardiac index was below 2.8 L/min/m². RESULTS. A total of 109 patients were studied. In nine patients, the therapeutic goals were achieved with volume expansion alone; all nine patients survived to leave the hospital. Fifty patients were randomly assigned to the treatment group, and 50 to the control group. During treatment, there were no differences between the two groups in mean arterial pressure or oxygen consumption, despite a significantly higher cardiac index and level of oxygen delivery in the treatment group ($p < 0.05$). Although the predicted risk of death during hospitalization was 34 percent for both groups, the in-hospital mortality was lower in the control group (34 percent) than in the treatment group (54 percent) ($p = 0.04$; 95%ci, 0.9 to 39.1%). CONCLUSIONS. The use of dobutamine to boost the cardiac index and systemic oxygen delivery failed to improve the outcome in this heterogeneous group of critically ill patients. Contrary to what might have been expected, our results suggest that in some cases aggressive efforts to increase oxygen consumption may have been detrimental.

Summary

Critically ill, 'high-risk' patients were randomized, after fluid resuscitation, to a control group or a treatment group in which dobutamine was administered to increase cardiac index (> 4.5 L/min/m²), oxygen delivery (> 600 ml/min/m²), and oxygen consumption (> 170 ml/min/m²). Fifty patients received dobutamine, and 50 were randomized to act as controls. Treatment with dobutamine successfully increased oxygen delivery and cardiac index to the target values, but there was an associated fall in oxygen extraction so that oxygen consumption was not increased. The treatment group had a significantly higher mortality (54%) than the control group (34%), which led to the study being discontinued at interim analysis.

Citation count**531**

Related references

1. Shoemaker WC, Appel PL, Kram HB *et al.* Prospective trial of supranormal values of survivors as therapeutic goals in high-risk surgical patients. *Chest* 1988; **94**: 1176–1186.

Key message

The administration of dobutamine to increase oxygen delivery and cardiac index does not improve outcome, and aggressive efforts to boost oxygen consumption may, in fact, be detrimental.

Why it's important

Several studies published before this had suggested that treating patients with fluids, adrenergic agents, and blood transfusions, to reach so-called supra-normal values of cardiac index and oxygen delivery, was beneficial. Some clinicians became so persuaded that they became too enthusiastic, and sometimes infused massive doses of dobutamine in patients who did not require it, with potentially deleterious effects. This study provided a note of caution, suggesting that such an approach was not necessarily of benefit to all patients, and could even increase mortality.

Strengths

Randomized, controlled trial. Most relevant end-point of mortality.

Weaknesses

Recommends the indiscriminate use of dobutamine at doses which are sometimes much above reasonable.

Relevance

The concepts underlying the hypothesis presented in this paper are very complex, and to believe that the routine administration of dobutamine could improve survival greatly oversimplifies the issue. Critically ill patients are a heterogeneous group, with varying disease processes and underlying comorbidities. Great care needs to be taken in extrapolating the results of studies in select groups of patients (primarily with shock) to all critically ill patients. Patients need to be fully assessed as individuals, and treatment must be tailored appropriately.

Title

Dopexamine reduces the incidence of acute inflammation in the gut mucosa after abdominal surgery in high-risk patients

Author

Byers RJ, Eddleston JM, Pearson RC, Bigley G, McMahon RFT

Reference

Crit Care Med 1999; **27**: 1787–1793

Abstract

OBJECTIVE: To evaluate the effect of dopexamine on the incidence of acute inflammation in the stomach/duodenum in patients undergoing abdominal surgery ≥ 1.5 hours with a minimum of one high-risk criterion. **DESIGN:** Prospective, randomized, double-blind, placebo-controlled study. This study was conducted as a side arm to a multicenter, multinational study. **SETTING:** University hospital in an adult intensive care unit. **PATIENTS:** Thirty-eight patients. **INTERVENTIONS:** Patients were stabilized with fluid, blood products, and supplementary oxygen to achieve predetermined goals: cardiac index > 2.5 L/min/m², mean arterial blood pressure of 70 mmHg, pulmonary arterial occlusion pressure of 10 mmHg, hemoglobin of 100 g/L, and arterial saturation of 94%. After stabilization, the study drug (either placebo [group A], dopexamine 0.5 mg/kg/min [group B], or dopexamine 2.0 mg/kg/min [group C]) was commenced. The study drug infusion was started 2 to 12 hours before surgery and infused for 24 hours after surgery. Estimation of upper gut blood flow was assessed using a gastric tonometer, and gastroscopy with biopsy was performed before surgery (after induction of anesthesia), and 72 hours after surgery. Comparisons were made between endoscopic findings and histologic proof of acute inflammatory changes. In addition, biopsies were assessed for the presence in the mucosa of mast cells, myeloperoxidase activity, and inducible nitric oxide synthase. **MEASUREMENTS AND MAIN RESULTS:** Intramucosal pH decreased significantly with time in all three groups ($p < 0.001$), reaching the lowest point at the end of surgery. There was no difference among the groups. Endoscopy visualized acute inflammatory changes in 58.3% of group A patients, 46.2% of group B patients, and 53.90% of group C patients after hemodynamic optimization. At 72 hours, dopexamine-treated patients compared with placebo-treated patients had a significantly lower incidence of gastric and duodenal acute inflammatory changes, as defined by myeloperoxidase activity (37.5% in groups B and C vs. 86% in group A; $p < 0.05$). **CONCLUSION:** Dopexamine in doses of 0.5 and 2.0 mg/kg/min affords significant histologic protection to the upper gastrointestinal tract mucosa 72 hours after operation in high-risk surgical patients undergoing abdominal surgery.

Summary

Thirty-eight patients undergoing abdominal surgery were randomized to receive infusions of either dopexamine (0.5 or 2 μ g/kg/min) or placebo. The infusions were started 2–12 hours pre-surgery, and continued for 24 hours after surgery. Gastric tonometry was used to assess upper gut blood flow, and gastroscopy with biopsy was performed before and 72 hours after surgery to assess inflammatory changes. There were no differences in intramucosal pH between the three groups. At 72 hours, dopexamine-treated patients had a significantly lower incidence of gastric and duodenal acute inflammatory changes compared with the placebo group.

Citation count

19

Related references

1. Schmidt W, Hacker A, Gebhard MM *et al.* Dopexamine attenuates endotoxin-induced microcirculatory changes in rat mesentery: role of beta2 adrenoceptors. *Crit Care Med* 1998; **26**: 1639–1645.

Key message

Dopexamine offers significant histological protection to the upper gastrointestinal tract mucosa in high-risk patients undergoing abdominal surgery.

Why it's important

The effect of adrenergic agents on regional blood flow is a topic of keen interest, as regional dysoxia – particularly in the gut – is believed to be related to the development of multiple organ failure. Dopexamine is a relatively new drug, and the literature is rather divided with regard to its effects on the distribution of blood flow to the organs. This study suggests that dopexamine can have beneficial effects on the gut by combined cardiovascular and anti-inflammatory effects.

Strengths

Randomized, controlled trial.

Weaknesses

Small numbers of patients. The placebo patients had higher APACHE II scores, which, although not significantly different, may nevertheless be relevant in a study with such small numbers of patients.

Relevance

Many disease processes in the critically ill are associated with an inflammatory response, including sepsis, pancreatitis, etc. Trauma and major surgery can also be associated with a marked inflammatory response. While this response may be of benefit, if prolonged, it can have detrimental effects on organ function. The possible role of anti-inflammatory agents in improving outcome in such conditions is under investigation. This study suggests that, in addition to their place in cardiovascular support, some adrenergic agents may also have important anti-inflammatory effects.

Pain relief and sedation in intensive care

Bernadette Currer and Maire Shelly

Introduction

Sedation was first used in intensive care to allow controlled ventilation. Over the last 30 years, sedation and ventilation have become inextricably linked. Nowadays, the aim of sedation is to have a comfortable patient at all times, particularly during the interventions necessary on the intensive care unit (ICU). To this end, sedation should be monitored, and safe drugs and techniques should be used. But have the lessons of the past 30 years really been taken on board? Probably not!

In this chapter, we present nine papers which feature different aspects of sedation and analgesia. We start with two surveys of practice carried out in the 1970s and 1980s which demonstrated a shift in the level of sedation aimed for, from a deeply sedated, very often paralyzed patient, to an asleep but easily rousable one. Meanwhile, in the search for an ideal sedative agent, the concept of a scoring system was introduced by Ramsay. In the UK, most ICUs were – and still are – run by anaesthetists, so this search for an ideal sedative led to the use of anaesthetic induction agents in intensive care, sometimes with adverse outcomes. An ideal sedative would obviously be safe, and this led to pursuit of an increased understanding of how a drug is handled by the body, particularly one that is critically ill. For instance, understanding that it was the accumulation of morphine-6-glucuronide that caused the apparent increased duration of action of morphine in patients with renal failure led to the safer use of morphine in this group.

As well as the agents themselves, the techniques used for sedation and analgesia came under scrutiny. Continuous intravenous (iv) infusions were particularly used. They were convenient, camouflaged poor staffing levels, and, in the UK, where physical restraint is unlawful and socially unacceptable, they allowed a compliant patient in a way that was apparently humane. However, evidence has now been put forward that shows that continuous iv infusion may increase patient morbidity and mortality. At the same time, epidural analgesia has been shown to provide a benefit in high-risk surgical patients. It seems, therefore, that our method of sedation and analgesia, and this encompasses both agents and technique, may have a significant effect on patient outcome.

As well as the physical well-being of our patients, their psychological well-being, during and after their admission, should be an issue for us. The last paper chosen discusses the problem of patients not remembering their ICU stay, or having bizarre memories and nightmares. It advocates follow-up providing support and information to patients, but further to this, we should consider the effect of sedation and analgesia on patient outcome as a whole.

The evidence shows that scoring systems to assess the level of sedation are available but little used beyond research, our agents are not ideal, and our chosen techniques may be causing our patients harm. Despite this evidence, our practice remains unchanged. Perhaps it is time to reassess our attitude to sedation. For whose comfort are we sedating our patients? If we are honest, maybe it is for our own. Sedation and analgesia are not an adjunct to care, but an intrinsic part of that care. Drugs and techniques should be chosen

which are appropriate to each individual patient's needs. The effect of the drug should be assessed against an appropriate end-point. We would not give noradrenaline without measuring, at least, blood pressure. Sedatives and analgesics are potentially dangerous drugs, and their use should be considered carefully and monitored effectively. We should also remember less dangerous alternatives, such as communication and kindness.

Title***The techniques used to sedate ventilated patients***

Author

Merriman HM

Reference*Intensive Care Med* 1981; **7**: 217–224

Abstract

A survey of sedation techniques for ventilated patients was performed by visiting 34 Intensive Care Units in Great Britain and Northern Ireland. The opiates in frequent use were phenoperidine (21 units - 62% of units), papaveretum (11 - 32%), and morphine (9 - 26%). Many units used more than one opiate. Levorphanol, buprenorphine, pethidine, fentanyl, and codeine were little used. Frequent use of diazepam was found in 22 units (64%), of lorazepam in 11 (32%), and of Althesin in four (12%). Other sedative drugs, droperidol, chlormethiazole, chlorpromazine, and ketamine were used on an occasional basis. Continuous sedation using nitrous oxide was employed in nine (26%) units – for more than 24 hours in six (18%). All units used pancuronium – 31 (91%) used it frequently. Curare was in frequent use in five units (15%). There was wide variation in the way in which the drugs were used. A compromise between the ideal and the practicable method was common, depending more upon shortage of trained nursing staff than upon lack of funds for equipment or expensive drugs. The depth of sedation thought to be ideal depended on the state of the patient, as well as the usual practice in the ICU; however, a majority (23 = 67%) of units aimed to keep most patients well sedated and detached from the ICU environment. The use of very large doses of opiate to obtain the stress response was thought helpful in only six units (18%), and then in a minority of patients.

Summary

For this study, the medical and nursing staff of 34 intensive care units (24 teaching hospitals and 10 district general hospitals) were questioned regarding their attitudes towards sedation of the critically ill, and their current sedative practice. The majority of units (23 of 34) felt that the ideal patient state was 'well sedated and detached from the ICU environment'. The drugs used were mainly opioids, phenoperidine most commonly, and benzodiazepines, usually diazepam. Althesin was used in only four units, and etomidate, although being given 'on trial', was not in regular use. Muscle relaxants were regularly used. Practice was found to vary between units, and within units, although certain drugs were thought to be helpful for specific patient problems. For instance, chlormethiazole was employed in those habituated to alcohol who were 'difficult to settle'. Althesin was used in head-injured patients who needed frequent assessment of their neurological status, and those requiring long-term ventilation were often given lorazepam, as it was thought to be less cumulative than diazepam. Monitoring and controlling the depth of sedation was by clinical judgement, not by formal scoring or protocols, and four units monitored plasma levels of diazepam, in an attempt to reduce the risk of accumulation and the associated slow patient recovery. Of the problems that were considered to be sedation-related, the most common were dysphoria and disorientation, and many of those questioned believed that too little sedation rather than too much was a cause of distress.

Citation count

58

Related references

1. Bion JF, Ledingham IMcA. Sedation in intensive care – a postal survey. *Intensive Care Med* 1987; **13**: 215–216.
2. Christensen BV, Thunedborg LP. Use of sedatives, analgesics and neuromuscular blocking agents in Danish ICUs 1996/97. *Intensive Care Med* 1999; **25**: 186–191.

Key message

At the time of this study (the late 1970s), the ideal patient state was thought to be well sedated and detached from the environment, and to this end a wide variety of drugs and techniques were employed, indicating that no ideal drug, or drug combination, had been found. The authors conclude that 'the search for new improved methods must go on'.

Why it's important

This was one of the first surveys of intensive care practice, and gives a useful snapshot of the attitudes and practices of its time. The use of sedatives and neuromuscular blockers was largely to allow relatively unsophisticated intensive care ventilation, and both were widely employed.

Strengths

1. A wide range of issues were raised and discussed to allow a detailed view of practice in these units.
2. Care was taken to try and ascertain what dictated sedation practice, and the possible influence of staffing levels, equipment availability, and cost restraints were considered.

Weaknesses

1. Given that there were probably >300 intensive care units in the UK at the time, the sample of 34 units cannot be assumed to be an accurate reflection of national practice.
2. The lack of numerical evidence meant that the pattern of drug use could only be described as 'frequent', 'sometimes', or 'rarely'.
3. Emphasis was made of the drugs used, but often little was said of the technique; for instance, it is not clear whether benzodiazepines were given by intermittent bolus or by continuous infusion.

Relevance

This study provided a baseline for a further survey performed by Bion in 1987, where the comparison of results demonstrated a shift in attitudes and practice in a relatively short space of time.

Title

Sedation in intensive care – a postal survey

Author

Bion JF, Ledingham IM

Reference

Intensive Care Med 1987; **13**: 215–216

Abstract

Not available

Summary

Of the 357 general ICUs in the UK, 189 responded to a questionnaire regarding their sedative practices; 93% of responding units were run by anesthetists, and in 55%, anesthetists were the sole clinicians. The level of sedation held 'ideal' by 69% of units was 'asleep but easily rousable'.

Most units employed either a combination of opiate and benzodiazepine, or an opiate alone. Compared with Merriman's survey, phenoperidine and diazepam, although still the most commonly used agents, were used less frequently as morphine and midazolam became more used. Continuous intravenous infusions had also gained popularity, with 65% of units using them routinely, while the paralysis of patients had fallen dramatically, from frequent use in 91% of units in 1981, to 16% in 1987.

Although the withdrawal of Althesin and etomidate, which pre-dated this letter, may have been expected to change practice, it seemed that relatively few units were affected. Most continued to use a benzodiazepine and an opiate. A defined sedation policy still belonged to the minority (40% of units), and most seemed happy to continue without a policy, as practice appeared satisfactory.

Citation count 55

Related references

1. Merriman HM. The techniques used to sedate ventilated patients. *Intensive Care Med* 1981; **7**: 217–224
2. Christensen BV, Thunedborg LP. Use of sedatives, analgesics and neuromuscular blocking agents in Danish ICUs 1996/97. *Intensive Care Med* 1999; **25**: 186–191.

Key message

The uniformity of prescribing and the lack of unit policies suggested that most units were happy with the drugs available to them, but this letter concludes by warning that 'the application of old agents in novel ways requires careful examination, and the establishment of clear policies'.

Why it's important

The shift in practice in the early 1980s, from rendering patients deeply sedated and often paralyzed, to asleep but easily rousable, is made evident by this survey.

Strengths

1. The timing of this survey demonstrates the lack of impact of the withdrawal of Althesin and etomidate, and the rapid change in attitude regarding the depth of sedation of the critically ill.
2. All general ICUs were surveyed, resulting in a large number of units responding.

Weaknesses

The study is presented as a letter and as such lacks detail. The method is not clearly described, detailed analysis of practice is omitted, and the question of why there was such a shift in attitude and practice is not raised.

Relevance

The relevance of this study is indistinguishable from its importance. It demonstrates the change in attitudes and practice, and provides a further baseline for comparison in the future.

Title

Controlled sedation with alphaxalone-alphadolone

Author

Ramsay MA, Savage TM, Simpson BR, Goodwin R

Reference

BMJ 1974; **2**: 656–659

Abstract

Not available

Summary

Alphaxalone-alphadolone (Althesin), diluted and given as a controlled infusion, was used as a sedative technique for 30 intensive care patients, mostly following cardiac surgery. To assess the technique, a scoring system was formulated with six levels of sedation. Awake levels: (1) patient anxious and agitated; (2) patient co-operative, orientated, and tranquil; (3) patient responds to commands only. Asleep levels, describing the patient's response to a light glabellar tap, or a loud auditory stimulus: (1) brisk response; (2) sluggish response; (3) no response. The patient's level of sedation was assessed every 5 minutes until the desired level was achieved, and thereafter every 30 minutes for the duration of sedation, the mean time being 4 days but extending up to 20 days. Following cessation of sedation, recovery was assessed clinically.

Citation count 614

Related references

1. Kong KL, Willatts SM, Prys-Roberts C. Isoflurane compared with midazolam for sedation in the Intensive Care Unit. *BMJ* 1989; **298**: 1277–1280.
2. Grounds RM, Lalor JM, Lumley J, Royston D, Morgan M. Propofol infusion for sedation in the Intensive Care Unit. *BMJ* 1989; **294**: 399–400.

Key message

Alphaxalone-alphadolone provided a wide and controllable range of sedation which could be easily and rapidly varied, thus allowing adequate tranquillity of restless and agitated patients, and also, because of its short duration of action, repeated assessment of the central nervous system. The optimal level of sedation was a score between 2 and 4.

Why it's important

This was the first study to offer a scoring system for assessing the level of sedation in the intensive care patient, and similar scores have been used since in assessing newer agents (see related references).

Strengths

1. The Ramsay scoring system was simple, and easily employed by nursing staff to maintain light sleep.

2. The study assessed the proportion of time with adequate sedation, the mean time to achieve good sedation, and the mean time to recovery, as well as details of all side effects.
3. Althesin was investigated here regarding its long-term infusion, and this had not previously been undertaken with any agent.

Weaknesses

1. The study group was small, containing only 30 patients, and therefore failed to demonstrate the important side effects which led the manufacturers to withdraw Althesin.
2. Despite constructing a simple and detailed scoring system, they rendered it poorly discriminating in practice by allowing a wide range of conscious levels (2–4) to indicate acceptable sedation.

Relevance

Although the result of the study was to advocate the use of Althesin, since proven to be an unsuitable agent, it was important in introducing the concept of scoring sedation levels, and of an optimal level for which to aim.

Title

Mortality amongst multiple trauma patients admitted to an intensive therapy unit

Author

Watt I, Ledingham IM

Reference

Anaesthesia 1984; **39**: 973–981

Abstract

A retrospective review of 428 severely injured patients admitted to an intensive therapy unit between 1969 and 1982 was performed. The patients' primary injuries were assessed using the injury severity score (ISS), and subsequent complications using the complications impact index and sepsis score. Between 1969 and 1980, mortality fluctuated between 19% and 29%, but rose to 47% ($p < 0.05$) during 1981–82, in spite of an unchanged ISS. The increased mortality was confined to ventilated patients surviving more than 5 days from injury, and was associated with multiple organ failure and severe infection. The rapid and sustained increase in mortality could not be explained by any obvious change in severity of injury or referral pattern. The only deliberate change in management related to the combination of analgesic/sedative drugs used in ventilated patients. During 1979 to 1982, mortality was 28% in patients given morphine with or without benzodiazepines, and 77% in those given morphine and etomidate ($p < 0.0005$). After discontinuation of the latter regimen (May 1983), and resumption of the former analgesic/sedative combination, mortality fell to 25% ($p < 0.005$). Possible mechanisms leading to increased mortality include adrenocortical insufficiency or depth of anaesthesia.

Summary

This was a retrospective review of the outcome of blunt trauma patients admitted to one ICU, during the 3-year period between 1979–1982. Increased mortality was demonstrated in the years 1981 and 1982 which could only be explained by the change in sedative regime used, because in all other ways the patient groups were similar. The increased deaths were in patients who were mechanically ventilated for >5 days, and most were associated with the development of infection. The offending agent was thought to be etomidate, which had been introduced into their practice for long-term sedation in 1981. Etomidate had been shown to cause suppression of adrenocortical function in rats, and the occurrence of an Addisonian crisis in one patient toward the end of 1981 prompted screening for hypocortisolemia, and steroid replacement where necessary. Despite this, the mortality rate that followed in 1982 was similarly high.

Citation count

73

Related references

1. Baker SP, O'Neil B, Haddon W, Long WB. The injury severity score: a method for describing patients with multiple injuries and evaluating emergency care. *J Trauma* 1974; **14**: 187–196.
2. Ledingham IM, Watt I. Influence of sedation on mortality in critically ill multiple trauma patients. *Lancet* 1983; **1**: 1270.

Key message

The retrospective study showed that the administration of etomidate in critically ill, major trauma patients was associated with an increased mortality. They advocated maximum caution in the use of long-term infusion of any sedative agent.

Why it's important

This was the first study to audit the practice of long-term infusion of any sedative agent, and to evaluate its possible influence on adverse outcome. It was also the only widely accepted paper at this time to detail harm from sedation.

Strengths

1. The use of the injury severity score, which had been shown to relate closely to outcome and validated the groups similarity.
2. Detailed and comprehensive case note examination during the period of increased mortality and the 2 previous years.
3. The diagnostic certainty of the patient group studied – multiple blunt trauma (excluding head injury).

Weaknesses

1. It is a retrospective review that was initiated by the findings of an audit.
2. The sedative regimes that they compare were not given concurrently, therefore it is possible that external factors influenced their results. However, since their initial audit had shown such a difference in mortality in the 'etomidate group' it would probably have been unethical to do a prospective randomized trial.

Relevance

Etomidate still is a widely used induction agent in this country, but this paper shows the potential danger of using an agent that is suitable in one setting in a different setting. Indeed, following the authors' initial letter, the Committee on Safety of Medicines issued a statement in the *Lancet* stressing that etomidate was licensed only for induction and maintenance of anesthesia, and that the manufacturers had agreed to cease promotion of the drug for sedation in ICU. Great Britain differs from many other countries in that most intensive care consultants are anesthetists, and perhaps this, and our familiarity with anesthetic agents, led to etomidate's use in long-term sedation without prospective evaluation of its safety. Following the findings of this study, every sedative agent with potential to be used in ICU is now tested regarding its effect on the adrenocortical axis, and there are guidelines for testing agents for long-term infusion.

Title

Metabolic acidosis and fatal myocardial failure after propofol infusion in children: five case reports

Author

Parke TJ, Stevens JE, Rice ASC, Greenaway CL, Bray RJ, Smith PJ, Waldmann CS, Verghese C

Reference

BMJ 1992; **305**: 613–616

Abstract

OBJECTIVE–To examine the possible contribution of sedation with propofol in the deaths of children who were intubated and required intensive care. **DESIGN**–Case note review. **SETTING**–Three intensive care units. **SUBJECTS**–Five children with upper respiratory tract infections, aged between 4 weeks and 6 years. **RESULTS**–Four patients had laryngotracheo-bronchitis, and one had bronchiolitis. All were sedated with propofol. The clinical course in all five cases was remarkably similar: an increasing metabolic acidosis was associated with brady-arrhythmia and progressive myocardial failure, which did not respond to resuscitative measures. All children developed lipemic serum after starting propofol. These features are not usually associated with respiratory tract infections. No evidence was found of viral myocarditis, which was considered as a possible cause of death. **CONCLUSION**–Although the exact cause of death in these children could not be defined, propofol may have been a contributing factor.

Summary

This is a review of five children, in three different hospitals, for whom death was unexpected given the initial pathology. They all had acute respiratory tract infections, which usually run a short self-limiting course requiring supportive therapy for the duration of symptoms – sequelae were uncommon. These children all developed a marked metabolic acidosis and cardiac failure, ultimately dying from a pharmacologically resistant asystole which led the investigators to look for a cause other than their presenting infection. Post-mortem examination was performed in three of the cases, and there was nothing to support the diagnosis of viral myocarditis which, with the lack of other possibilities, was considered the most likely cause of death in these patients. The blood in all cases was lipemic, and in the three who had post-mortem examination, the livers showed fatty change while the hearts were essentially normal. Propofol had been used in large doses (although less than half the manufacturer's recommended maximum rate in infants), and was known to cause vasodilation and bradycardia, more severe in children given their increased vagal tone. With the limited experience of propofol for the sedation of children and its possible role in these deaths, the authors of this paper recommended that it should no longer be used in pediatric intensive care.

Citation count

204

Related references

1. Martin PH, Murphy BVS, Petros AJ. Metabolic, biochemical and haemodynamic effects of infusion of propofol for long-term sedation of children undergoing intensive care. *BJA* 1997; **79**: 276–279.
2. Hatch DJ. Propofol in paediatric intensive care. *BJA* 1997; **79**: 274–275.

Key message

The simple extrapolation of adult experience into pediatric practice has risks, as does the use of high-dose single agents. Combining synergistic agents, in doses well below their toxic range, could be a safer approach. Until further data are available on the appropriate dose range for propofol in children, the authors advise that it should not be used.

Why it's important

Since the beginning of propofol use in pediatric intensive care during the late 1980s, there had been a number of reports of central nervous system irritability, and one death reported in Denmark, where a 2-year-old child developed hypotension, multi-organ failure, and hepatomegaly. This paper contained the first case reports in the UK of unexplained pediatric deaths linked to propofol. It therefore also contains the message that sedative agents may cause harm.

Strengths

1. The cases showed remarkable similarity, suggesting a common pathophysiology.
2. Post-mortem evidence to exclude myocarditis was available.
3. The usual excellent prognosis for the presenting conditions strengthens the argument against propofol.

Weaknesses

Propofol is suspected, but cannot be confirmed, as a contributor to these deaths. Its implication is essentially due to the lack of any other cause, and is based on supposition.

Relevance

Following these reports, the Committee on Safety of Medicines in the UK issued adverse effect warnings, leading to the use of propofol in pediatric intensive care being all but abandoned. However, the findings here do not point conclusively to propofol, and its use has continued in the sedation of children in other parts of the world. For instance, it is still used in North America, from where reported data showed that >300 children were sedated for up to 2 weeks at doses of 0.44–26.3 mg/kg/h with no adverse events.

Title

Pharmacokinetics of morphine in two children before and after liver transplantation

Author

Shelly MP, Cory EP, Park GR

Reference

Br J Anaesth 1986; **58**: 1218–1223

Abstract

Plasma morphine, morphine-3-glucuronide, and morphine-6-glucuronide concentrations were measured (HPLC) in two children immediately before orthotopic liver transplantation, and in the postoperative period. Both of the patients had end-stage hepatic failure, but one also had impaired renal function before operation and was oliguric during and after surgery. Both patients metabolized morphine rapidly, but in the patient with renal failure, the metabolites appeared to accumulate. Morphine has active metabolic products, and the accumulation of these in patients with impaired renal function may lead to a clinically observable prolongation of its effect.

Summary

Two children undergoing liver transplantation for end-stage liver failure were studied to assess the change in morphine and morphine metabolite levels following a single dose of morphine. The children, a boy aged 2.5 years with normal renal function, and a girl aged 3.5 years with undiagnosed renal impairment, were given a 1 mg/kg bolus of morphine on induction of anesthesia, and before the start of transplant surgery. While the boy maintained a good urine output throughout, the girl was anuric during surgery, and produced very little urine in the first 24 hours postoperatively. The two patients were found to metabolize morphine at equal rates, and by 24 hours, levels were zero. However, while the boy was rousable and required further analgesia within 10 hours, the girl was narcotised, only requiring further analgesia at 31 hours once a urine output was established with diuretics. Blood samples indicated that the difference between the two patients was in plasma levels of morphine-3-glucuronide and morphine-6-glucuronide, with high levels being maintained in the presence of renal impairment. Therefore, accumulation of active metabolites, particularly morphine-6-glucuronide, and not of morphine itself, appears to be responsible for its prolonged duration of action in renal failure.

Citation count 33

Related references

1. Osborne RJ, Joel SP, Slevin ML. Morphine intoxication in renal failure: the role of morphine-6-glucuronide. *BMJ* 1986; **292**: 1548–1549.

Key message

Morphine can be metabolized rapidly even in the presence of end-stage liver failure, but renal impairment allows accumulation of active metabolites, producing marked sedation and continuing analgesia.

Why it's important

Previous studies had shown abnormal elimination of morphine in renal impairment, which recovered as renal function improved. However, they used an assay for morphine which was later shown to cross-react extensively with morphine-6-glucuronide. This study was the first to demonstrate that it was metabolites, and not morphine itself, that accumulated.

Strengths

1. High pressure chromatography was used here to determine the levels of morphine and its metabolites. This is more accurate than the radioimmunoassay used in previous studies.
2. Detailed explanation of the clinical observations is given.

Weaknesses

1. Only two of morphine's metabolites were assayed. The role of others was not assessed.
2. There were no blood samples taken between 1 hour and 24 hours (by which time morphine levels were nil in both patients). If there was a difference in the time for morphine elimination, this study could not demonstrate it.
3. Only two patients were studied.

Relevance

Morphine is regularly used as an analgesic in intensive care, usually by continuous infusion. This paper (and Osborne's report in the same year) took an important step in clarifying its pharmacokinetics, and explaining a clinical observation in biochemical terms, so improving the safety of morphine use in critically ill patients with renal impairment.

Title***The use of continuous i.v. sedation is associated with prolongation of mechanical ventilation***

Author

Kollef MH, Levy NT, Ahrens TS, Schaiff R, Prentice D, Sherman G

Reference*Chest* 1998; **114**: 541–548

Abstract

STUDY OBJECTIVE: To determine whether the use of continuous iv sedation is associated with prolongation of the duration of mechanical ventilation. DESIGN: Prospective observational cohort study. SETTING: The medical ICU of Barnes-Jewish Hospital, a university-affiliated urban teaching hospital. PATIENTS: Two hundred forty-two consecutive ICU patients requiring mechanical ventilation. INTERVENTIONS: Patient surveillance and data collection. MEASUREMENTS AND RESULTS: The primary outcome measure was the duration of mechanical ventilation. Secondary outcome measures included ICU and hospital lengths of stay, hospital mortality, and acquired organ system derangements. A total of 93 (38.4%) mechanically ventilated patients received continuous iv sedation, while 149 (61.6%) patients received either bolus administration of iv sedation (n = 64), or no iv sedation (n = 85) following intubation. The duration of mechanical ventilation was significantly longer for patients receiving continuous iv sedation compared with patients not receiving continuous iv sedation (185 +/- 190 h vs 55.6 +/- 75.6 h; p < 0.001). Similarly, the lengths of intensive care (13.5 +/- 33.7 days vs 4.8 +/- 4.1 days; p < 0.001) and hospitalization (21.0 +/- 25.1 days vs 12.8 +/- 14.1 days; p < 0.001) were statistically longer among patients receiving continuous iv sedation. Multiple linear regression analysis, adjusting for age, gender, severity of illness, mortality, indication for mechanical ventilation, use of chemical paralysis, presence of a tracheostomy, and the number of acquired organ system derangements, found the adjusted duration of mechanical ventilation to be significantly longer for patients receiving continuous iv sedation compared with patients who did not receive continuous iv sedation (148 h [95% confidence interval: 121, 175 h] vs 78.7 h [95% confidence interval: 68.9, 88.6 h]; p < 0.001). CONCLUSION: We conclude from these preliminary observational data that the use of continuous iv sedation may be associated with the prolongation of mechanical ventilation. This study suggests that strategies targeted at reducing the use of continuous iv sedation could shorten the duration of mechanical ventilation for some patients. Prospective randomized clinical trials, using well-designed sedation guidelines and protocols, are required to determine whether patient-specific outcomes (eg, duration of mechanical ventilation, patient comfort) can be improved compared with conventional sedation practices.

Summary

This paper aimed to assess the pattern of sedation practice in an intensive care unit and its effect on outcome, measured primarily by duration of mechanical ventilation (secondary measures included length of ICU and hospital stay). The patient group studied comprised those admitted to a medical intensive care unit with an age range of 18–105 years! They found the prescribing of intravenous sedation to be inconsistent, and when those receiving continuous intravenous sedation were compared with those receiving intermittent boluses or none at all, the former group was found to have an increased duration of mechanical ventilation, even following adjustment for confounding variables.

Citation count

182

Related references

1. Terai T, Yukioka H, Fujimori M. Administration of epidural bupivacaine combined with epidural morphine after oesophageal surgery. *Surgery* 1997; **121**: 359–365.

Key message

Continuous iv sedation is potentially harmful. It appears to be associated with an increased duration of mechanical ventilation, and may prolong both ICU and hospital stay. These factors, as well as having obvious cost implications, may contribute to an overall poorer outcome.

Why it's important

In the past, mechanical ventilation has required the administration of sedative agents, and the two have become associated. However, with more sophisticated and 'patient-friendly' ventilators, alternatives should be considered. The awake patient may need more attention, and communication is difficult, but reducing the use of continuous sedation may improve patient outcome.

Strengths

Although this was a prospective cohort study, and not a randomized controlled trial, a linear regression model was used to adjust for confounding variables, and therefore the authors are able to suggest a strong association with prolonged mechanical ventilation. A randomized controlled trial is now being undertaken on the basis of their findings

Weaknesses

1. As an observational study, a direct causal relationship between continuous iv sedation and increased duration of mechanical ventilation cannot be confirmed.
2. The study is isolated to one intensive care unit.
3. Agent use was limited to benzodiazepines and opioids (lorazepam and fentanyl most commonly), therefore their findings may not be true for the use of other agents, such as propofol. The indications for continuous iv sedation were not given. The patients receiving such sedation were more likely to have acute respiratory distress syndrome or acute lung injury, although in this study the differences between the groups did not reach statistical significance.

Relevance

The possible harm of sedation in the ICU has been investigated in the past, but the agents, and not the technique of administration, were mainly questioned. Two seemingly ideal agents (Althesin and etomidate) were withdrawn from use in the early 1980s. Nowadays, new agents are more stringently tested, but once introduced into intensive care practice, their use seems to be relatively uncontrolled, and protocols are rarely used. This study now looks specifically at technique and ignores the individual agents. It has the important message that our *mode* of administration of sedation may be harming our patients.

Title

Epidural anesthesia and analgesia in high risk surgical patients

Author

Yeager MP, Glass D, Neff RK, Brinck-Johnson T

Reference

Anesthesiology 1987; **66**: 729–736

Abstract

The authors conducted a randomized controlled clinical trial to evaluate the effect of epidural anesthesia and postoperative analgesia (EAA) on postoperative morbidity in a group of high-risk surgical patients. A total of 53 patients were admitted to the study, 28 received EAA, and 25 received standard anesthetic and analgesic techniques without EAA. Surgical “risk” was evaluated preoperatively and found to be comparable in the two groups. When compared to control patients, patients who received EAA had a reduction in the overall postoperative complication rate ($p = 0.002$), and in the incidence of cardiovascular failure ($p = 0.007$) and major infectious complications ($p = 0.007$). Urinary cortisol excretion, a marker of the stress response, was significantly diminished during the first 24 postoperative hours in the group receiving EAA ($p = 0.025$). Finally, hospital costs were significantly reduced for patients who received EAA ($p = 0.02$). The authors conclude that EAA exerted a significant beneficial effect on operative outcome in a group of high risk surgical patients.

Summary

This study aimed to determine whether epidural anesthesia and analgesia had an effect on outcome in high-risk patients undergoing major surgery, when compared with a standard general anesthetic technique using opioid analgesia. The authors found a pronounced reduction in postoperative complications in the epidural group, with 9 of 28 patients suffering one or more complications compared with 19 of 25 patients in the standard treatment group. The total complications were 12 in the epidural group, and 49 in the standard treatment group, of whom 4 died, whereas all of the patients with epidurals survived. The group numbers are small because these striking results caused the authors to halt their study. However, this affects interpretation of the results, as it is possible that by chance the standard treatment group were the sicker group.

Citation count 510

Related references

1. McPeck B. Inference, generalizability, and a major change in Anesthetic practice. *Anesthesiology* 1987; **66**: 723–724.
2. Watson A, Allen P. Influence of thoracic epidural analgesia on outcome after resection for esophageal surgery. *Surgery* 1997; **121**: 359–365.
3. Blass J, Atraender S, Moerlen J. Complication-free early extubation following abdomino-thoracic esophagectomy. *Anaesthetist* 1991; **40**: 315–323.

Key message

Epidural anesthesia and postoperative analgesia may significantly decrease postoperative morbidity and mortality.

Why it's important

The important message of this paper needs little explanation. A relatively simple technique, already in use for major abdominal and thoracic surgery, could significantly improve patient outcome. Whether this is a direct effect, or secondary to associated factors such as a reduced opioid requirement, better analgesia, or improved respiratory function, is not clear. This paper demonstrates a need for further research in this area.

Strengths

1. It is a prospective randomized controlled trial.
2. Groups with equivalent surgical risk factors were identified prospectively.

Weaknesses

1. The patient numbers are small because the study finished early, and it may have found a difference that does not actually exist.
2. The 'standard' anesthetic technique used in this study was left to the discretion of the individual anesthetist for each patient, and therefore did vary.
3. The study was not blinded.

Relevance

When this paper was published in the late 1980s, it was accepted that epidurals could produce improved analgesia, but in otherwise fit patients an effect on outcome was equivocal. The results here in a group of high-risk patients were striking, although as an accompanying editorial pointed out, with small numbers, confounding variables could have influenced the results, and therefore they should be regarded cautiously until further studies confirm them. Further studies in the early 1990s did go on to confirm the beneficial effect of epidurals. This study was one of the first to support a real benefit, and has influenced practice since.

Title

Where is the harm in not knowing: care after intensive care

Author

Griffiths RD, Jones C, Macmillan RR

Reference

Clinical Intensive Care 1996; **7**: 144–145

Abstract

Not available

Summary

This hypothesis paper addresses the issue of the patient's experience of their time on the ICU, and how it affects their re-entry into 'normal life' with their family and society in general. Immediate effects had been studied showing anxiety, sleep disturbance, and hallucinations, and the few studies investigating longer-term effects reported social isolation, avoiding company, showing less affection to partners, and dependence on others to make decisions. The main causes of distress to patients were not knowing what happened to them, only receiving second-hand information through relatives, and ongoing physical problems, particularly weakness. Many were found to have unrealistic expectations of their recovery. Relatives also suffered, exhibiting hyper-vigilance, and conflicts at home were common. After discharge, the general practitioners (GPs) hold responsibility for the patient's care, but they know little about the patterns of problems experienced by a patient after a period of intensive care. The authors suggest a structured program that could be implemented by ICU staff, to rebuild a patient's physical and emotional strength, with involvement of relatives to lessen the risk of conflict. In other areas, such as cardiac rehabilitation after myocardial infarction, this approach has been shown to decrease hospital re-admission rates and the number of GP visits.

Citation count

9

Related references

1. Jones J, Hoggart B, Withey J, Donaghue K, Ellis BW. What the patients say: a study of reactions to an intensive care unit. *Intensive Care Med* 1979; **5**: 89–92.
2. Benzer H, Mutz N, Pauser G. Psychological sequelae of intensive care. *Int Anesthesiol Clin* 1983; **21**: 169–181.

Key message

Not knowing what happened to them is a cause of distress to patients, and not a blessing. ICU staff should be prepared to follow up patients after ICU discharge. As the authors say – 'Now is the time for care after intensive care!'.

Why it's important

The long-term and psychological effects of an ICU stay have been studied very little, and although some hospitals are now establishing follow-up clinics to review and support patients, this is by no means the norm. This article encourages ICU staff to think beyond

the organ failure and the ICU stay, and to fill this gap in patient care which is leaving ICU survivors and their relatives fending for themselves, with limited knowledge about what actually happened.

Strengths

This article draws together the limited research available as evidence to express the need for further development of support services in this area.

Weaknesses

This is a hypothesis paper, and as such gives arguments to convince and not refute the hypothesis.

Relevance

The experiences of patients on ICU and their subsequent recall are intimately linked to the environment that we create for them, and the sedative and analgesic regimes that we use. The follow-up, described and advocated here, provides us with added insight into the effect of our sedation practice. It demonstrates that patients with little memory of their ICU stay suffer high rates of anxiety and depression. We can no longer assume that a sedated patient, unlikely to recall events, is better off than one who is awake and aware of their surroundings.

Monitoring

E. Makings and C.J. Hinds

Introduction

The ability to monitor patients continuously, to recognize the significance of changes in monitored variables, and to respond rapidly and appropriately to such changes is fundamental to the successful management of the critically ill. To be effective and safe, such monitoring requires the presence of an adequate number of appropriately trained nursing and medical staff at or near the bedside, and is thus a defining characteristic of the intensive care or high dependency environment. As well as allowing immediate recognition of changes in the patient's condition, monitoring techniques can also be used to establish or confirm a diagnosis, to assess the severity of the patient's condition, to follow the evolution of the illness, and to assess the response to treatment.

In this section, we have chosen a number of original papers which we believe have been pivotal in the development of monitoring techniques, and have since gained wide acceptance for monitoring the cardiovascular, respiratory, and neurological function of critically ill patients. In many instances – for example, pulmonary artery catheterization, cardiac output determination, and intracranial pressure monitoring – the techniques described have also contributed significantly to our understanding of the pathophysiology of critical illness, and have been used extensively in studies investigating the physiological effects of various therapeutic interventions. In making our selection, we have also been mindful of the importance of reducing the complications and costs associated with invasive monitoring by the development and application of simple, non-invasive techniques, such as pulse oximetry and big toe temperature, as well as less invasive but clinically effective devices, such as the esophageal Doppler. Some monitored variables were also considered to warrant inclusion because of their ability to provide early warning of deterioration (such as mixed venous oxygen saturation and big toe temperature), or prognostic information (such as blood lactate). Other novel and interesting techniques which have undoubtedly made important contributions to our understanding and treatment of critical illness, such as gastric tonometry and transcutaneous gas tension monitoring, have been omitted because of continuing uncertainties about their value in clinical practice.

Title

Measurement of cardiac output by thermal dilution in man

Author

Branthwaite MA, Bradley RD

Reference

J Appl Physiol 1968; **24**: 434–438

Abstract

Not available

Summary

A technique for the measurement of cardiac output in man by thermal dilution, particularly during acute disturbances of the circulation, is described and validated. A thermistor mounted at the tip of a miniature cardiac catheter is positioned in the pulmonary artery, and temperature change is recorded following the injection of room temperature saline or dextrose through a catheter in the internal jugular vein. Correlation with the direct Fick technique is shown to be highly significant. The method is particularly valuable where serial measurements at short intervals are required, because the result is available immediately. Cannulation of the internal jugular vein was found to have much wider application than the measurement of cardiac output, including measurement of central venous pressure and long-term intravenous therapy.

Citation count 187

Related references

1. Khalil HH, Richardson TQ, Guyton AC. Measurement of cardiac output by thermal dilution and direct Fick method in dogs. *J Appl Physiol* 1966; **21**: 1131–1135.
2. Forrester JS, Ganz W, Diamond G, McHugh T, Chonette DW, Swan HJ. Thermodilution cardiac output determination with a single flow directed catheter. *Am Heart J* 1972; **83**: 306–311.
3. Boldt J, Menges T, Wollbrack M, Hammermann H, Hempelmann G. Is continuous cardiac output measurement using thermodilution reliable in the critically ill patient? *Crit Care Med* 1994; **22**: 1913–1918.
4. Bradley RD. Diagnostic right heart catheterization with miniature catheters in severely ill patients. *Lancet* 1964; **2**: 941–942.
5. Fegler G. Measurement of cardiac output in anaesthetized animals by a thermal dilution method. *Q J Exp Physiol* 1954; **39**: 153–164.

Key message

Cardiac output can be determined in man easily, safely, and accurately by thermal dilution. The technique described also allows continuous recording of right atrial and pulmonary artery pressures.

Why it's important

This pioneering work paved the way for the incorporation of a thermistor into the tip of balloon flotation catheters for measurement of cardiac output by thermodilution. The ability to determine cardiac output accurately and repeatedly in critically ill patients has revolutionized our understanding of the pathophysiology and treatment of shock, sepsis, and organ failure, although some have questioned the clinical value of direct measurements of cardiac output.

Strengths

Cardiac outputs determined by thermal dilution were compared with the 'gold standard' direct Fick method in a variety of patients (some breathing spontaneously, some receiving intermittent positive-pressure ventilation, IPPV), over a wide range of cardiac outputs. Potential sources of error are thoroughly discussed.

Advantages of the thermal, as opposed to dye dilution technique, include the ability to perform repeated measurements at short intervals with no elevation of the baseline, and the absence of recirculation. Also there is no need for blood sampling, and the cardiac output can be calculated rapidly.

Weaknesses

The technique required the insertion of two catheters, and relied on the operator having the necessary skill to position a catheter in the pulmonary artery without the assistance of a balloon for flotation.

Relevance

Although previously developed and described in animals, this is the first report of the successful application of the thermal dilution technique in man. More recently, continuous monitoring of cardiac output using a modified pulmonary artery catheter with a heated filament has become feasible.

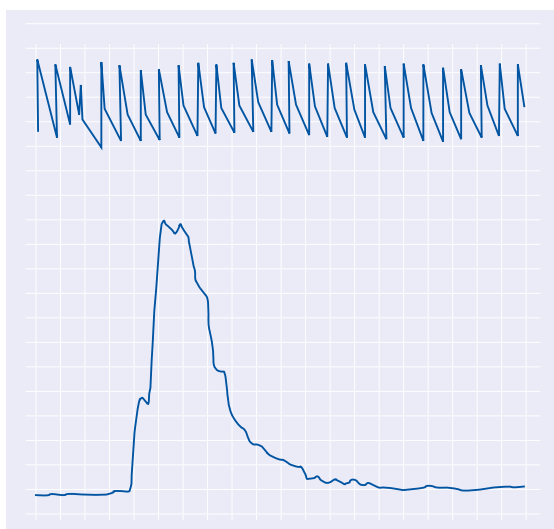

Fig. 17-1. Upper trace, arterial blood pressure; lower trace, thermal-dilution curve recorded in the pulmonary artery

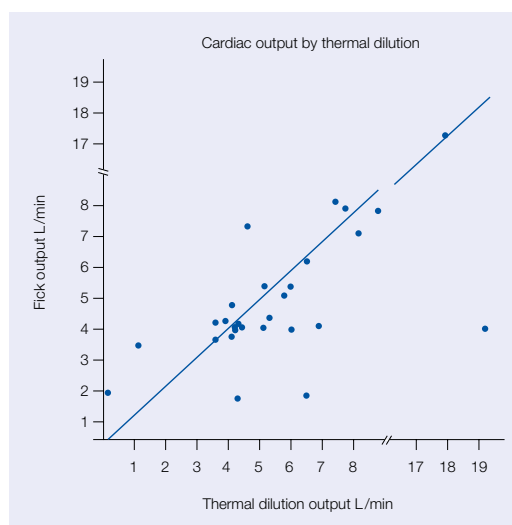

Fig. 17-2. Regression line and values of cardiac output obtained by comparison of the direct Fick and thermal dilution methods

Title

Catheterisation of the heart in man with use of a flow directed balloon-tipped catheter

Author

Swan HJC, Ganz W, Forrester J, Marcus H, Diamond G, Chonette D

Reference

N Engl J Med 1970; **283**: 447–451

Abstract

Not available

Summary

The authors demonstrated that pressures in the right side of the heart and pulmonary capillary wedge pressure can be obtained rapidly and safely by cardiac catheterization without the aid of fluoroscopy. A no. 5 Fr double lumen catheter with a balloon just proximal to the tip is inserted into the right atrium, guided by pressure monitoring. The balloon is then inflated with air. The balloon is carried by blood flow through the right side of the heart into the smaller branches of the pulmonary artery. When the balloon is inflated in this position, wedge pressure is obtained. The average time for passage of the catheter from the right atrium to the pulmonary artery was 35 seconds in the first 100 passages in 37 critically ill patients and 33 patients undergoing diagnostic catheterization. The frequency of premature beats was minimal, and no other arrhythmias were seen. Other complications included perforation or rupture of the balloon, and thrombosis in relation to the catheter. The authors suggested that this technique could be widely applied to the study of the central circulation in man.

Citation count 1302

Related references

1. Lategola M, Rahn H. A self-guiding catheter for cardiac and pulmonary arterial catheterization and occlusion. *Proc Soc Exp Biol Med* 1953; **84**: 667–668.
2. Swann DG. The utility of pulmonary artery catheterization. *Br J Anaesth* 2000; **85**: 501–503.
3. Connors AF, Speroff T, Dauson NV *et al*. The effectiveness of right heart catheterization in the initial care of the critically ill patient. *JAMA* 1996; **276**: 889–897.

Key message

Using a flow directed, balloon-tipped catheter, the right ventricle and pulmonary artery can be catheterized rapidly and safely without fluoroscopy in seriously ill patients.

Why it's important

The development of the 'Swan-Ganz' catheter and its widespread introduction into clinical practice and research was a pivotal event in the history of critical care medicine. Previously, diagnostic right heart catheterization had been performed with semi-rigid cardiac catheters. This required fluoroscopic guidance and the development of considerable technical skill in catheter manipulation.

Strengths

This paper is a clear description of the effectiveness and safety of a prototype balloon flotation catheter for determining right heart pressures at the bedside in critically ill patients.

Weaknesses

This is not the first description of the successful use of balloon flotation catheters (e.g. see Lategola and Rahn 1953). The clinical utility of the measurements obtained is not addressed in this publication, neither is the incidence and importance of complications fully assessed. In particular, infectious complications are not reported, and, because of the relatively small number of critically ill patients studied, the incidence of less common complications cannot be evaluated. Post-mortem findings are not reported.

Relevance

The extensive use of balloon-flotation pulmonary artery catheters has contributed enormously to our understanding of the pathophysiology of critical illness and its treatment. It is also clear that clinical hemodynamic assessment is frequently inaccurate, that pulmonary artery catheterization improves diagnostic accuracy, and that clinically relevant information is obtained which often prompts changes in treatment. Nevertheless, the clinical value of this technique, and in particular its influence on outcome, has been disputed. Some studies have even suggested that the use of these catheters may be associated with increased morbidity and mortality. This may be due to the treatments used in response to the measurements obtained, or inexperience with the use of these catheters and interpretation of the data, rather than to complications of the catheter itself.

Title

Experimental and clinical studies on lactate and pyruvate as indicators of the severity of acute circulatory failure (shock)

Author

Weil MH, Afifi AA

Reference

Circulation 1970; **41**: 989–1001

Abstract

Not available

Summary

The increase in lactate (L) and pyruvate (P) content of arterial blood during experimental and clinical circulatory shock, and the extent to which such increases serve as measures of oxygen deficit and irreversible injury, were investigated.

A standardized method for production of hemorrhagic shock in the Wistar rat was employed. During a 4 hour bleeding period, oxygen consumption was reduced to approximately 40% of control value, pH was reduced from 7.39 to 7.08, and a concurrent increase in L from 0.8 to 6.06 mM, and in P from 0.07 to 0.18 mM was observed. Cumulative oxygen debt correlated with log L ($r = 0.50$, $p < 0.005$), and both were significantly related to survival. Correlation of cumulative oxygen debt and survival, both with P and with calculated values of the lactate pyruvate ratio (L/P) and excess lactate (XL), were of no higher magnitude. Neither the measurement of P nor the computation of L/P or XL improved predictability.

In 142 patients who presented with clinical manifestations of circulatory shock (62 survivors, 80 non-survivors), the best empirical discrimination between survivors and those who died was provided by measurement of L. The combination of XL and L/P with L failed to improve discrimination. In this series of patients, as L increased from 2.1 to 8.0 mM, the estimated probability of survival decreased from 90% to 10%.

These studies confirm that in circulatory shock, L alone serves as a reliable indicator of oxygen deficit and probability of survival. Neither the measurement of P nor the computation of L/P or XL improves the reliability of L as a measure of cumulative oxygen debt, or its value as an indicator of survival.

Citation count 332

Related references

1. Suistomaa M, Ruukonen E, Kari A, Takala J. Time pattern of lactate and lactate to pyruvate ratio in the first 24 hours of intensive care emergency admissions. *Shock* 2000; **14**: 8–12.
2. Bakker J, Gris P, Coffemils M, Kahn RJ, Vincent JL. Serial blood lactate levels can predict the development of multiple organ failure following septic shock. *Am J Surg* 1996; **171**: 221–226.

3. James JH, Luchette FA, McCarter FD, Fischer JE. Lactate is an unreliable indicator of tissue hypoxia in injury or sepsis. *Lancet* 1999; **354**: 505–508.

Key message

In hemorrhagic shock, the rise in blood lactate correlates with cumulative oxygen debt. In patients with circulatory shock of various etiologies, blood lactate levels are closely related to the probability of death.

Why it's important

This and related studies have had a major influence on our attempts to understand the pathophysiology of circulatory shock, including the mechanisms of organ failure and 'irreversible shock'. The concepts of cumulative oxygen debt and lactic acidosis as an indicator of tissue hypoxia, and more recently 'supply dependency', have also prompted a re-evaluation of the goals for resuscitation of high risk surgical and other critically ill patients.

Strengths

This was a meticulously performed experimental study, which included the measurement of oxygen consumption in rats with hemorrhagic shock. The clinical study involved a large number of patients with circulatory shock.

Weaknesses

Only hemorrhagic shock was studied in rats, while the clinical study included patients with a variety of causes of circulatory shock. Also, not all of the rats were included in the survival analysis.

Relevance

Although it is now recognized that hyperlactemia is multifactorial, and is not necessarily always a consequence of anaerobic glycolysis due to inadequate oxygen delivery, the close relationship between persistently elevated blood lactate levels, the development of organ failure, and outcome has been confirmed repeatedly. Whether normalization of lactate levels is a better guide to the adequacy of resuscitation than restoration of hemodynamics, urine output, and peripheral perfusion remains controversial. Similarly, the value of determining the lactate/pyruvate ratio continues to be studied and debated.

Title

Spectrophotometric monitoring of arterial oxygen saturation at the fingertip

Author

Yoshiya I, Shimada Y, Tanaka K

Reference

Med Biol Eng Comput 1980; **18**: 27–32

Abstract

A non-invasive oximeter that analyzes the oxygen saturation of arterial blood in the fingertip is described. The light, after attenuating the infrared portion to avoid thermal injury, is applied to the fingertip through an optical transmitter made of glass fibers. The transmitted light is transferred to an optical reception system, where a spectrophotometric determination of oxygen saturation is performed by considering only the change in the attenuation of light caused by the inflow of arterial blood into the fingertip. The correlation between the oxygen saturation measured with this instrument (y) and that with the blood gas method (x), was $y = 0.907x + 8.592$ with a standard deviation and a correlation coefficient of 0.135% and 0.983, respectively. The reproducibility was assessed in a healthy subject by measuring the oxygen saturation repeatedly 60 times. The mean saturation was $95.82 \pm 0.675\%$ (mean \pm standard deviation). The instrument was found to be useful in monitoring arterial oxygenation in patients with respiratory failure in the authors' intensive care unit. One of the disadvantages of the instrument is that the measurement is interrupted when the fingertip changes its position in relation to the light beam.

Citation count 114

Related references

1. McKay WP, Noble WH. Critical incidents detected by pulse oximetry during anaesthesia. *Can J Anaesth* 1988; **35**: 265–269.
2. Cullen DJ, Nemaskal JR, Cooper JB, Zaslavsky A, Dwyer MJ. Effect of pulse oximetry, age and ASA physical status on the frequency of patients admitted unexpectedly to a postoperative intensive care unit. *Anesth Analg* 1992; **74**: 181–188.
3. Moller JT, Pederson T, Rasmussen LS *et al.* Randomized evaluation of pulse oximetry in 20,802 patients. I. Design, demography, pulse oximetry failure rate, and overall complication rate. *Anesthesiology* 1993; **78**: 436–444.
4. Moller JT, Johannessen NW, Espersen K *et al.* Randomized evaluation of pulse oximetry in 20,802 patients. II. Perioperative events and postoperative complications. *Anesthesiology* 1993; **78**: 445–453.

Key message

The oxygen saturation of arterial blood can be monitored non-invasively and continuously using an oximeter applied to the fingertip. Accuracy, stability, and reproducibility are adequate for clinical monitoring.

Why it's important

Continuous monitoring of the oxygen saturation of arterial blood by pulse oximetry is now considered to be essential during anesthesia and recovery from surgery, as well as in high dependency and intensive care units, and during transport of critically ill patients. It now seems incredible that we managed without these devices! They have been shown to shorten the time to the detection of critical events, to decrease the number of patients admitted unexpectedly from the operating theater to the intensive care unit, and to reduce the frequency of episodes of hypoxemia and myocardial ischemia during anesthesia.

Strengths

Pulse oximeters continuously monitor a physiological variable vital for the preservation of life – the amount of oxygen in arterial blood. They are simple, reliable, non-invasive, widely applicable, relatively cheap, and portable devices that do not require calibration.

Weaknesses

Measurements are subject to movement artifact, and may be unreliable in those with a low cardiac output, poor peripheral perfusion, or arrhythmias. Because pulse oximeters measure the absorption of light at only two wavelengths, the presence of significant amounts of carboxy- or methemoglobin can lead to inaccuracies. Jaundice may result in falsely low readings. Pulse oximeters measure the oxygen saturation of arterial blood with only limited accuracy, and may, therefore, be falsely reassuring at saturations in the low 90s. They are unable to warn of hypoventilation and carbon dioxide retention when supplemental oxygen is being administered.

Relevance

The principle of pulse oximetry was first used to assess oxygen saturation in pilots during World War II, but its introduction into clinical practice had to await this description of a more practical device.

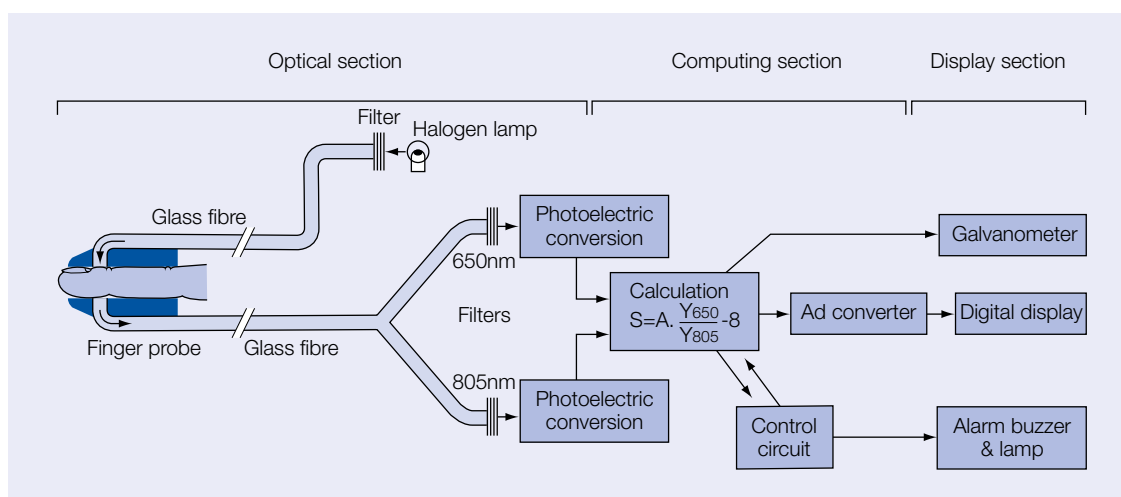

Fig. 17-3. Block diagram of the instrument Light emitted by the halogen lamp is transferred by the glass fibres and applied to the fingertip. The transmitted light is led through 650 and 805 nm filters reaching photocells that convert the light energy into an electrical signal. The computer section calculates S and the control circuit determines if the photoelectric output is adequate for the analysis

Title

Continuous recording of the ventricular-fluid pressure in patients with severe acute traumatic brain injury

Author

Lundberg N, Troupp H, Lorin H

Reference

J Neurosurg 1965; **22**: 581–590

Abstract

Not available

Summary

This was a preliminary report in which the authors for the first time described the use of an intra-ventricular cannula connected to a strain gauge transducer to measure intracranial pressure continuously in 30 patients with severe head injuries. They used changes in intracranial pressure as a guide to the management of these patients, including the use of interventions such as induced hypothermia, hyperventilation, infusions of urea, and surgical exploration. The authors also concluded that spontaneous variations in intracranial pressure are characteristic of intracranial hypertension, whatever the cause, and that simultaneous recording of intracranial pressure and blood pressure might be particularly helpful.

Citation count

67

Related references

1. Horsley JS. The intracranial pressure during barbitol narcosis. *Lancet* 1937; **i**: 141–143.
2. Moss E, Gibson JS, McDowell DG, Gibson RM. Intensive management of severe head injuries. *Anaesthesia* 1983; **38**: 214–225.
3. Miller JD, Becker DP, Ward JD *et al*. Significance of intracranial hypertension in severe head injury. *J Neurosurg* 1977; **47**: 503–516.

Key message

This study demonstrated the importance of increases in intracranial pressure as a cause of cerebral dysfunction in head-injured patients, and suggested that continuous intracranial pressure monitoring could be used as a more rational basis for treatment.

Why it's important

This was the first time that intracranial pressure monitoring was used to guide treatment in traumatic brain injury. To this day, intracranial pressure is still the most commonly monitored variable in unconscious, mechanically ventilated, head-injured patients.

Strengths

Intraventricular fluid pressure is a sensitive and accurate measure of overall intracranial pressure. The presence of an intraventricular catheter not only allows measurement of intracranial pressure, but also enables the clinician to remove cerebrospinal fluid in order to control intracranial hypertension.

Weaknesses

There is a significant risk of introducing infection with this technique, although in this series there was no evidence of this complication. Intraventricular pressure measurement may prove difficult or impossible in those in whom the ventricles are compressed by cerebral swelling or hematoma.

Relevance

Since this paper was published, continuous monitoring of intracranial and systemic blood pressure to guide management has become standard practice in many units. Intracranial pressure measurement has also contributed significantly to our understanding of the pathophysiology of severe head injury, and to the development of treatments designed to limit 'secondary' brain injury.

Title

Temperature of the great toe as an indication of the severity of shock

Author

Joly HR, Weil MH

Reference

Circulation 1969; **39**: 131–138

Abstract

Not available

Summary

The authors set out to establish whether changes in skin temperature would provide an objective indication of the presence and severity of shock. Hemodynamic and temperature measurements were obtained with the aid of a digital computer. Values obtained 3 hours after admission, and 3 hours before discharge or death in 100 patients who presented with clinical signs of circulatory shock, were analyzed. Temperature was measured with standard thermistor probes at five sites: the digital pad of the third finger, the large toe, the deltoid region of the arm, the lateral portion of the thigh, and the rectum.

A significant correlation was demonstrated between the cardiac output and the temperature of the great toe ($r = 0.71$). Correlations were marginally improved when corrected for differences in ambient temperature, but were not improved by core (rectal)/peripheral temperature difference. Unsurprisingly, toe temperature was poorly correlated with arterial pressure. Of the four sites at which skin temperature was measured, the toe provided the best indication of changes in blood flow. A rising toe temperature in the interval between admission and discharge was a reliable indicator of a good prognosis, and vice versa.

Citation count 101

Related references

1. Woods I, Wilkins RG, Edwards JD *et al.* Danger of using core/peripheral temperature gradient as a guide to therapy in shock. *Crit Care Med* 1987; **15**: 850–852.
2. Bailey JM, Levy JH, Kopel MA, Tobia V, Grabenkart WF. Relationship between clinical evaluation of peripheral perfusion and global haemodynamics in adults after cardiac surgery. *Crit Care Med* 1990; **18**: 1353–1356.
3. Murdoch IA, Qureshi SA, Mitchell A, Huggon IC. Core peripheral temperature gradient in children: does it reflect important changes in circulatory haemodynamics? *Acta Paediatr* 1993; **82**: 773–776.

Key message

Toe temperature provides objective information about peripheral blood flow, the severity of shock, the response to treatment, and prognosis. It is not necessary to include core

temperature, nor probably ambient temperature, in the calculation. Of the four sites at which skin temperature was measured, the toe provided the best indication of changes in blood flow. Consistent with clinical experience, much, but not all, of the pertinent information is also contained in the finger temperature.

Why it's important

This paper clearly demonstrated the importance of peripheral temperature as a guide to the diagnosis and management of circulatory shock.

Strengths

Measurement of great toe temperature is safe, simple, cheap, readily available, and non-invasive. It is not affected by such factors as patient movement, and is an objective, continuous measurement.

Weaknesses

There is some uncertainty about the strength of the relationship between toe temperature and cardiac output. Conditions such as pre-existing vascular disease and the presence of an intra-aortic balloon pump may confound the measurement.

Relevance

Peripheral temperature is now monitored routinely in the majority of intensive care units as a guide to the adequacy of resuscitation, and as an early warning of deterioration. It remains an extremely useful clinical sign – 'cold and clammy' versus 'warm and well perfused'. This paper also highlights the importance of assessing alterations in flow rather than pressure.

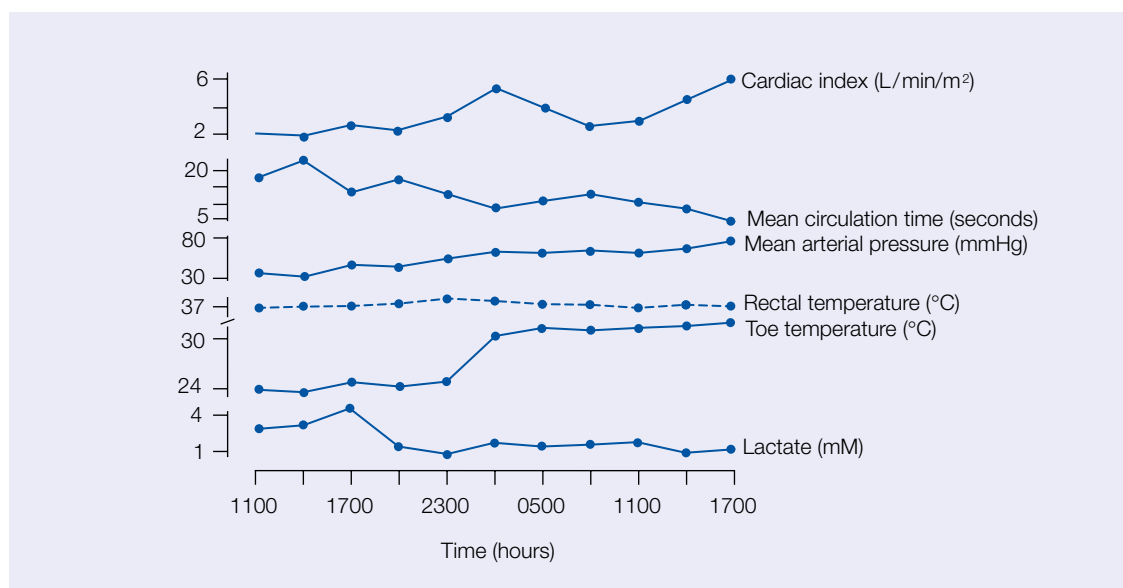

Fig. 17-4. Favourable course of a patient with drug overdose and shock

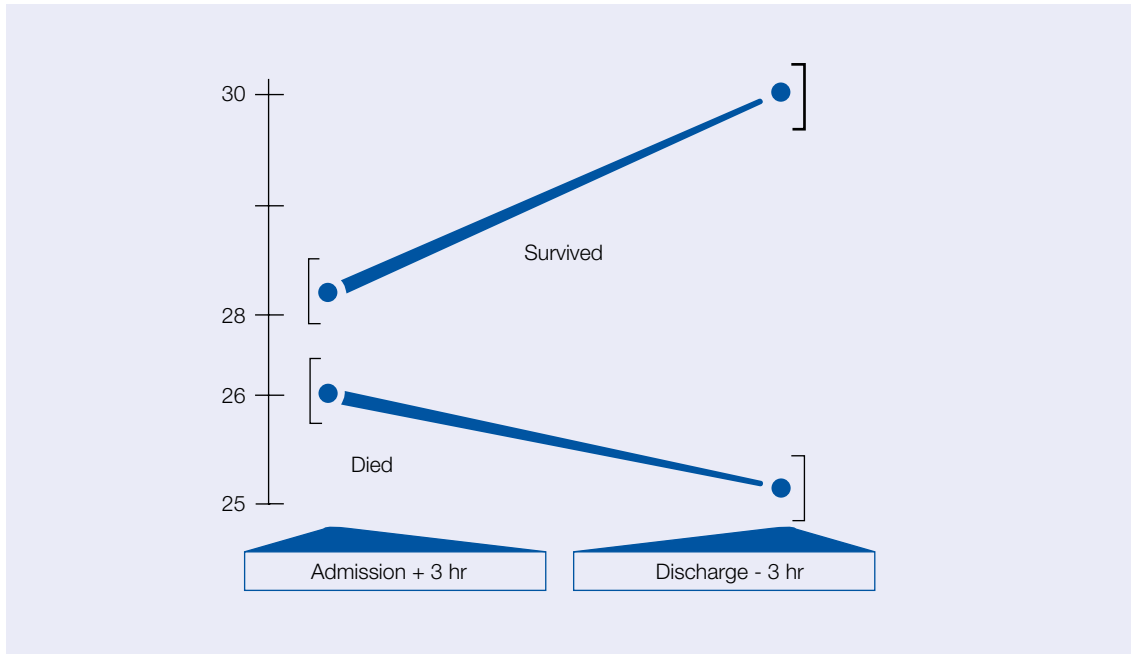

Fig. 17-5 Changes in toe temperature in survivors and patients who died

Title

Estimation of cardiac output soon after intracardiac surgery with cardiopulmonary bypass

Author

Boyd AD, Tremblay RE, Spencer FC, Bahnson HT

Reference

Ann Surg 1959; **150**: 613–626

Abstract

Not available

Summary

In this study, 34 patients who had undergone cardiac surgery with cardiopulmonary bypass were studied by placing fine polyvinyl catheters under direct vision at the time of surgery into the pulmonary artery, left atrium, and femoral artery. The pulmonary artery catheter was inserted through the outflow tract of the right ventricle. Oxygen consumption was measured using a basal metabolism apparatus from which pure oxygen was breathed, and oxygen utilization was graphically recorded. Simultaneously, arterial and mixed venous blood samples were taken from the fine catheters for determination of oxygen content or saturation. Cardiac output was then estimated by the Fick method. The authors demonstrated a close relationship between cardiac output, mixed venous oxygen saturation/content, and outcome. They also concluded that the mixed venous oxygen saturation obtained from the pulmonary artery, which was an accurate reflection of cardiac output, was most helpful in evaluating the patients' cardiovascular status, and often gave a clue to an inadequate circulation which was not evident by other signs.

Citation count

91

Related references

1. Armstrong RF, Secker Walker J, St Andrew D, Cobbe SM, Cohen SL, Lincoln JCR. Continuous monitoring of mixed venous oxygen tension (PvO₂) in cardiorespiratory disorders. *Lancet* 1978; **i**: 632–634.

Key message

Mixed venous oxygen content or saturation is an accurate reflection of the adequacy of the cardiac output for an individual patient, and is therefore more informative than cardiac output alone. Also, reductions in mixed venous oxygen content can precede by several hours the clinical signs of a low cardiac output, and may thereby serve as an early warning of subsequent deterioration.

Why it's important

This original paper clearly demonstrated the potential of mixed venous oxygen saturation monitoring to detect deterioration in critically ill patients, and as a guide to management.

Strengths

Mixed venous oxygen saturation is a reflection of tissue oxygenation, a fall therefore implies that the supply of oxygen to the tissues is inadequate. Reductions in mixed venous oxygen saturation often precede changes in other monitored variables or clinical signs, and it has been suggested that continuous monitoring of mixed venous oxygen saturation can provide a useful early indication of decompensation.

Weaknesses

Changes in mixed venous oxygen saturation require careful interpretation; they must not be considered in isolation, and should prompt further investigation to ascertain the cause. A fall in mixed venous content may be due to arterial hypoxemia, anemia, a fall in cardiac output, an increase in oxygen consumption, or any combination of these. Moreover, in sepsis, tissue hypoxia is largely due to impaired oxygen uptake or utilization, and mixed venous oxygen saturation is therefore often normal or high.

Relevance

Mixed venous oxygen saturation can now be determined continuously using a modified pulmonary artery catheter incorporating a fiberoptic oximeter, and as such is used extensively in clinical practice. However, the precise clinical indications for monitoring this variable have not yet been clearly defined.

Title

The nitrous oxide method for the quantitative determination of cerebral blood flow in man: theory, procedure and normal values

Author

Kety SS, Schmidt CF

Reference

J Clin Invest 1947; **27**: 476–483

Abstract

Not available

Summary

In 1945, the authors reported the determination of cerebral blood flow in man by the use of inhaled nitrous oxide in low concentration, a technique which permitted for the first time quantitative clinical measurement of this important physiological variable. Numerous modifications were subsequently made to the procedure, and the underlying theory was subjected to extensive experimental evaluation. This report is a description of the technique as employed by the authors in over 300 determinations, an examination of its underlying theory and validity, and values obtained with its use in 34 studies on 14 normal young men.

Citation count

60

Related references

1. Kety SS, Schmidt CF. The determination of cerebral blood flow in man by the use of nitrous oxide in low concentration. *Am J Physiol* 1945; **143**: 53.
2. Doolette DJ, Upton RN, Grant C. Agreement between ultrasonic Doppler venous out-flow and Kety Schmidt estimates of cerebral blood flow. *Clin Exp Pharmacol Physiol* 1999; **26**: 736–740.
3. Cook DJ, Anderson RE, Michenfelder JD *et al.* Cerebral blood flow during cardiac operations: comparison of Kety Schmidt and Xenon-133 clearance methods. *Ann Thorac Surg* 1995; **59**: 614–620.

Key message

This ingenious technique is a modification of the Fick principle, in which cerebral blood flow can be accurately determined by inhaling 10% nitrous oxide.

Why it's important

The Kety-Schmidt method of measuring cerebral blood flow has in the past been used extensively in clinical investigations, and is still considered the 'gold standard' against which all other more recently introduced techniques are compared.

Strengths

Although this method was developed and described in the 1940s, it is still considered to be the most accurate method of measuring cerebral blood flow. It is based on sound physiological principles, and is accurate over a wide range of flows. It is possible to perform repeated measurements on the same subject while the needles are still in place, provided that at least 20 minutes elapse between measurements. The technique also allows the calculation of $CMRO_2$.

Weaknesses

This technique is complex and difficult to perform. Skill and training are required to obtain reliable results. Specific problems include selecting the dominant internal jugular vein for sampling, and contamination of samples from the internal jugular vein with blood from the extracerebral circulation. Inaccuracies can also be introduced if the mask through which the 10% nitrous oxide is inhaled does not fit perfectly around the patient's face, allowing air to be entrained.

Relevance

Although more sophisticated non-invasive techniques are now available which have largely superseded nitrous oxide inhalation in clinical practice, the Kety-Schmidt method is still used for validation.

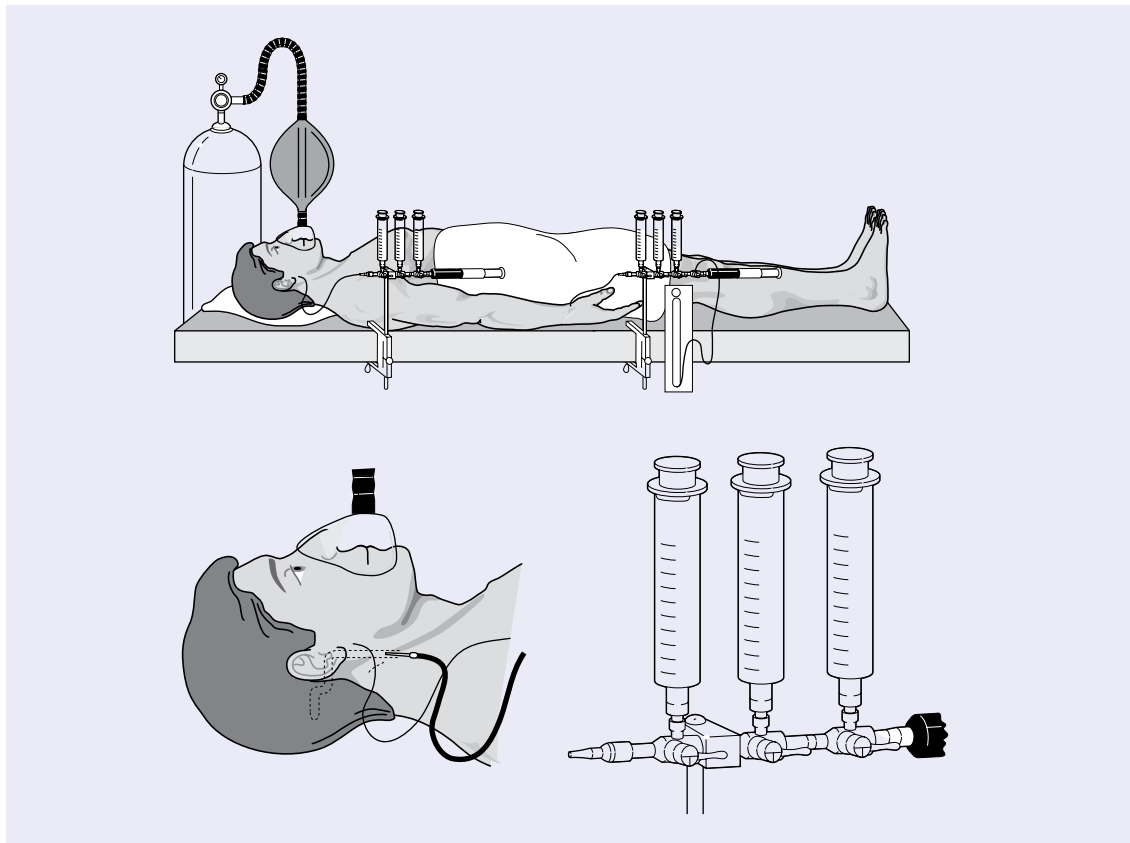

Fig. 17-6. Experimental set-up for cerebral blood flow determination. The position of the needle in the internal jugular is shown, as well as plastic tubing, manifolds, sampling and flushing syringes, and inhalation system. Mean arterial blood pressure is read from a mercury manometer attached to the arterial manifold. Only the expiratory valve on the mask is shown, the inspiratory valve is between the fluted tubing and the mask

Title

Continuous haemodynamic monitoring by esophageal Doppler

Author

Singer M, Clarke J, Bennett ED

Reference

Crit Care Med 1989; **17**: 447–452

Abstract

A new 5.1-mHz continuous wave esophageal Doppler system is described for continuous hemodynamic monitoring in ventilated patients. Information is obtained from the size, shape, and changes in shape of the velocity waveforms of descending aortic blood flow. Minute distance, the product of waveform area (stroke distance) and heart rate, provides a measure of cardiac output. Good agreement between this technique and thermodilution was shown for cardiac output changes with 238 paired measurements made in 38 patients. The coefficient of variation was lower for Doppler (3.8%) than for simultaneous thermodilution measurements (6.2%). Seventy-eight changes in left ventricular filling, systemic vascular resistance, or inotropic state produced consistent alterations in waveform shape, with a narrow-based waveform being indicative of hypovolemia. This development marks a significant advance in the technique, and provides a useful alternative to invasive hemodynamic monitoring, both in the ICU and perioperatively.

Summary

The authors evaluated a 5.1-mHz continuous wave esophageal Doppler system for continuous hemodynamic monitoring in ventilated patients. A visual display of the spectral analysis of Doppler frequency shifts, back-scattered from blood flow in the descending aorta, allows non-invasive assessment of cardiac output, and recognition of reduced left ventricular filling. Changes in cardiac output are accurately followed, causes being identified by characteristic alterations in waveform shapes due to changes in left ventricular filling, afterload, and inotropic state. Accuracy is improved by recognizing non-insonation of midstream flow by the presence of poorly defined waveforms with increased spectral dispersion. The use of 5.1-mHz ultrasound reduces the risk of additional insonation of other thoracic vasculature, and yet provides excellent signals from descending aortic blood flow. Good agreement was shown between this technique and thermodilution cardiac output determination. Changes in left ventricular filling, systemic vascular resistance, or inotropic state produced consistent alterations in waveform shape, with a narrow-based waveform being indicative of hypovolemia.

Citation count 109

Related references

1. Gan T, Arrowsmith J. The oesophageal Doppler monitor: a safe means of monitoring the circulation (Editorial). *BMJ* 1997; **315**: 893–894.
2. Soni N. Swan song for the Swan Ganz catheter? (Editorial). *BMJ* 1996; **313**: 763–764.
3. Sinclair S, James S, Singer M. Intraoperative intravascular volume optimisation and length of hospital stay after repair of proximal femoral fracture: a randomised controlled trial. *BMJ* 1997; **315**: 909–912.

Key message

Changes in cardiac output can be accurately followed in ventilated patients using this relatively simple, non-invasive device. The use of visual display and 5.1-mHz ultrasound improves accuracy, and allows more complete hemodynamic assessment through 'pattern evaluation'.

Why it's important

The esophageal Doppler is becoming an increasingly popular method of hemodynamic monitoring. It is simple and relatively non-invasive compared with the insertion of a pulmonary artery catheter, and provides a continuous visual appreciation of circulatory changes. Optimization of the circulating volume with accurate fluid resuscitation guided by use of the esophageal Doppler has been shown to reduce morbidity and mortality in high-risk surgical patients.

Strengths

Changes in cardiac output, combined with an assessment of whether cardiac output is high, normal, or low, is often sufficient to guide hemodynamic management. Alterations in shape accurately reflect hemodynamic changes. Waveform size reflects cardiac output, changes in area follow alterations in stroke volume, and a narrow-based waveform is suggestive of an under-filled ventricle. The esophageal Doppler is relatively non-invasive, and therefore the risk of complications is reduced compared with pulmonary artery catheterization. Running costs are negligible, and some probes are re-usable. Insertion of the probe and acquisition of signals is relatively simple, and minimal expertise is required. Online visual display allows easy positioning, correct focusing, and identification of artifact. Use of 5.1-mHz ultrasound reduces the risk of additional insonation of other thoracic vasculature, yet provides excellent signals from descending aortic blood flow. The larger, more rigid probes facilitate insertion and allow greater stability.

Weaknesses

Some practice is required to obtain reproducible results. Also, determination of absolute values for cardiac output requires calculation of aortic cross-section, which involves the assumption that the aorta is cylindrical. It also has to be assumed that aortic cross-section remains constant, and that a fixed proportion of the total blood flow travels down the descending aorta. One other weakness of the technique is that it is only suitable for use in sedated, usually ventilated, patients.

Relevance

The esophageal Doppler is a useful, less invasive alternative to pulmonary artery catheterization for the diagnosis and treatment of hemodynamic instability in critically ill patients. It is particularly useful for the non-operative management of high-risk surgical patients.

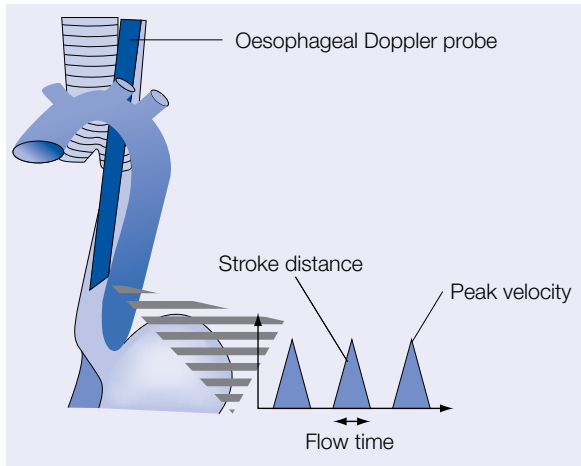

Fig. 17-7. *Oesophageal Doppler probe continuously measures velocity waveforms from the descending thoracic aorta. With a nomogram stroke distance (area under waveform) provides an estimate of stroke volume. Acceleration and peak velocity indicate myocardial performance, while flow time is related to circulating volume and peripheral resistance*

Scoring systems

Derek C. Angus MB, CHB, MPH

Introduction

At the heart of optimal clinical medicine is the ability to prognosticate. Understanding a patient's likely outcome, and how that outcome might change depending on alternative interventions, is essential if care is to be optimized. Perhaps nowhere is this issue both more important and more difficult than in intensive care. The ICU is home to a wide array of expensive technologies that can both help and harm the critically ill patient; ICU patients often have multiple complex conditions that make prognostication difficult, and decisions must be made rapidly and courageously, as time is of the essence.

It is not surprising, therefore, that intensive care has seen the development of extremely sophisticated tools to aid clinicians in predicting outcome. A common theme to risk prediction scores (or scoring systems) is their heavy reliance on acute derangements in physiology as predictors of subsequent survival. The first paper, by Virginia Apgar, recognized that simple quantification of the physiology of newborns was strongly predictive of subsequent course in the neonatal period. The next two papers similarly quantified simple clinical measures to predict mortality in single disease processes – head injury, and acute pancreatitis.

The fourth paper represents one of the first observations that the magnitude of physiological derangement was predictive of subsequent outcome regardless of underlying conditions. This observation set the stage for generic, rather than disease-specific, scoring systems, as exemplified by the fifth paper, reporting on the APACHE II scoring system. APACHE II is one of the most widely quoted papers in all of medicine, let alone intensive care, and, more than 15 years after its publication, is still used to stratify patients in clinical trials throughout the world. Indeed, the US Food and Drug Administration recently incorporated the use of the APACHE II system into the labeling for a new antiseptic therapy. The sixth paper, PRISM, is the standard-bearer for risk prediction in pediatric critical care, and, like APACHE II, has been found to have excellent predictive characteristics, and has stood the test of time remarkably well, even as the nature of pediatric care continues to change.

The Therapeutic Intervention Scoring System is a little different from the other papers, as it tallies not physiological derangement, but the magnitude of ICU support, and has proved to be an extremely valuable tool for tracking ICU resource use in both clinical trials and daily practice. Furthermore, it has been extremely valuable across international boundaries where more traditional measures of resource use often fail. The eighth paper, MPM II, is perhaps the most elegant paper, describing the development and validation of an alternative scoring system to the APACHE system. It also has the advantage that a score can be calculated at admission, rather than after observation for 24 hours. The last two papers represent attempts to use scoring systems to guide or evaluate care. The first is a state-wide project to evaluate the quality of coronary bypass surgery by comparing each hospital's observed mortality to that predicted by a scoring instrument. This paper is one of the first examples of what has now become a standard approach at the core of virtually all large regional attempts to evaluate and improve healthcare quality, not only in intensive care, but in many medical domains. Finally, SUPPORT was the first large-scale project that attempted to use scoring systems prospectively to improve clinical care. Although it failed, the lessons learned have been considerable, and have helped set the stage for improved attempts to optimize care through systematic and accurate risk prediction with ICU scoring systems.

Title

A proposal for a new method of evaluation of the newborn infant

Author

Apgar V

Reference

Curr Res Anesth Analg 1953; **32**: 260–267

Abstract

Not available

Summary

Apgar proposed, on the basis of clinical theory, a 10-point scale that assesses five simple physiological parameters. She validated the scale by assessing the mortality rates of 2096 newborn infants with low, moderate, and high Apgar scores.

Citation count 820

Related references

1. Apgar V. The newborn (Apgar) scoring system. Reflections and advice. *Pediatr Clin North Am* 1966; **13**: 645–650.
2. Chamberlain G, Banks J. Assessment of the Apgar score. *Lancet* 1974; **2**: 1225–1228.
3. Weinberger B, Anwar M, Hegyi T, Hiatt M, Koons A, Paneth N. Antecedents and neonatal consequences of low Apgar scores in preterm newborns: a population study. *Arch Pediatr Adolesc Med* 2000; **154**: 294–300.

Key message

Early assessment of a child's cardiorespiratory status, reflex irritability, muscle tone, and color, using a simple practical score, can provide important prognostic information that can be used to guide care, including the need for intensive care.

Why it's important

Although often overlooked by adult intensive care specialists, this is arguably the original intensive care severity score. In part because of its simplicity, it is also the most widely used. Not only every baby in America, but every baby in the developed world and many others beside, are assessed by the Apgar score.

Strengths

Simple, practical, and strongly correlated with outcome.

Weaknesses

There is little to criticize about this score. Obviously, it does not provide sophisticated measures of physiological reserve or derangement, and can only be used for general

prognostication. For example, the decision to initiate therapies for newborn distress, such as mechanical ventilation, inhaled NO, or surfactant, cannot be based on the Apgar score alone. However, the ability to make quick and consistent triage decisions based on this score makes it one of the most practical and relevant scores available.

Relevance

Despite its age, the Apgar score remains a highly relevant and practical scale.

Title

Assessment of coma and impaired consciousness: a practical scale

Author

Teasdale GM, Jennett B

Reference

Lancet 1974; **2**: 81–84

Abstract

Not available

Summary

This paper presents the Glasgow Coma Scale (GCS). No patient data are used. The authors present a simple way of producing a score, ranging from 3 to 15, to assess coma and impaired consciousness (see Figure). The score is based on independent assessment of three separate neurological components – eyes, speech, and motor function. The purpose of the score was to develop a common metric that reliably charted a patient's course, could be documented by physicians and nurses alike, and would facilitate information exchange between caregivers.

Citation count 3791

Related references

1. Jennett B, Bond M. Assessment of outcome after severe brain damage. *Lancet* 1975; **1**: 480–484.
2. Teasdale G, Knill-Jones R, van der Sande J. Observer variability in assessing impaired consciousness and coma. *J Neurol Neurosurg Psychiatry* 1978; **41**: 603–610.

Key message

The GCS is a simple, reproducible score that can be used to chart a patient's course, and facilitate care in the management of head-injured patients.

Why it's important

The GCS is, with Ranson's criteria, one of the most robust and well-known examples of a disease-specific scoring system (in this case, head trauma). Although not initially developed as a predictive tool (but rather simply a tool to chart a patient's course), its strong correlation with outcome makes the GCS an extremely valuable tool in the care of patients with altered consciousness.

Strengths

It works. The GCS, despite being developed conceptually, and based on little patient data initially, has proven to be a remarkably reliable, easy, and predictive scale for assessing coma and impaired consciousness.

Weaknesses

In this paper, the major weakness was that there were no patient data upon which to determine how reliably the GCS correlated with either the underlying condition, or subsequent outcome.

A weakness of the GCS is that the correlation between score and outcome varies with the cause of coma. It was initially intended for head trauma. Its use is not as straightforward in situations such as drug overdose, or patients receiving sedation.

Relevance

The GCS remains very relevant. Many major generic severity scoring systems and organ failure scoring systems continue to rely heavily, if not entirely, on the GCS as a measure of neurological function.

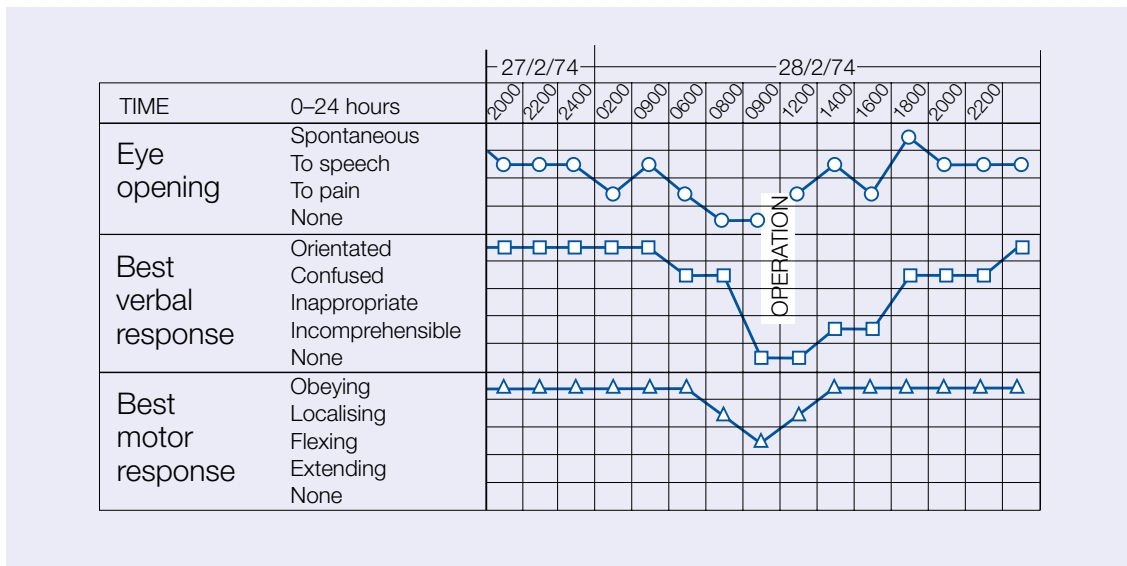

Fig. 18-1. A chart for recording assessment of consciousness using the Glasgow Coma Scale (adapted from Teasdale GM, Jennett B. *Lancet* 1974; 2: 81-84)

Title

Statistical methods for quantifying the severity of clinical acute pancreatitis

Author

Ranson JH, Pasternack BS

Reference

J Surg Res 1977; **22**: 79–91

Abstract

Not available

Summary

This observational outcome study included a set of early clinical and physiological measurements on 300 patients with probable or definite acute pancreatitis. Using univariate and multivariate statistical tests, the authors explored the predictive capability of several proposed markers of severity of illness, where the dependent variable was mortality or prolonged ICU course. The authors elegantly demonstrated that nine variables appeared to have robust, independent associations with adverse outcome, and were therefore suggested to be key risk factors for severe pancreatitis.

Citation count 142

Related references

1. Ranson JH. Diagnostic standards for acute pancreatitis. *World J Surg* 1997; **21**: 136–142.
2. Puolakkainen P, Schroder T. New trends in the diagnosis and treatment of severe acute pancreatitis. *Ann Med* 1990; **22**: 375–376.
3. De Bernardinis M, Violi V, Roncoroni L, Boselli AS, Giunta A, Peracchia A. Discriminant power and information content of Ranson's prognostic signs in acute pancreatitis: a meta-analytic study. *Crit Care Med* 1999; **27**: 2272–2283.

Key message

Some, but not all, clinical and physiological markers of acute pancreatitis can be shown statistically to be independent risk factors for an adverse course.

Why it's important

This paper was one of the first and most well-known attempts to objectively evaluate which proposed risk factors were independent predictors of adverse outcome. The resulting 'Ranson's criteria' were simple and easy to adopt in clinical practice by clinicians worldwide in the management of acute pancreatitis.

Strengths

The final result is a simple set of clinical criteria that can easily be applied in clinical practice. The variable selection was based on robust statistical analysis.

Weaknesses

Two-center study, no overall risk of death, no distinction between end-points, and no validation cohort.

Relevance

This study is one of the most famous examples of disease-specific, rather than generic, scoring systems for early risk prediction information in disease management.

Title

Prognosis in acute organ-system failure

Author

Knaus WA, Draper EA, Wagner DP, Zimmerman JE

Reference

Ann Surg 1985; **202**: 685–693

Abstract

This prospective study describes the current prognosis of patients in acute Organ System Failure (OSF). Objective definitions were developed for five OSFs, and then 5677 ICU admissions from 13 hospitals were monitored. The number and duration of OSFs were linked to outcome at hospital discharge for each of the 2719 ICU patients (48%) who developed OSF. For all medical, and most surgical admissions, a single OSF lasting more than 1 day resulted in a mortality rate approaching 40%. Among both medical and surgical patients, two OSFs for more than 1 day increased death rates to 60%. Advanced chronologic age increased both the probability of developing OSF, and the probability of death once OSF occurred. Mortality for 99 patients with three or more OSFs persisting after 3 days was 98%. The two patients who survived were both young, in prior excellent health, and had severe but limited primary diseases. These results emphasize the high death rates associated with acute OSF, and the rapidity with which mortality increases over time. The prognostic estimates provide reference data for physicians treating similar patients.

Summary

This was an observational outcome study. Categorizing a patient's course by the number and type of organ failures that developed acutely, the authors then demonstrated that organ failure was strongly associated with outcome. Particularly ominous, a patient who developed ≥ 3 organ failures for ≥ 3 days had near 100% mortality (see Figure). These observations led to (a) the development of numerous organ failure scores; (b) the notion that organ failure and physiological derangement, might be predictive of mortality; and (c) reinforcement of a care model that conceptualized critical illness as the number and duration of organ failures.

Citation count 688

Related references

1. Baue AE. Multiple, progressive, or sequential systems failure. A syndrome of the 1970s. *Arch Surg* 1975; **110**: 779–781.
2. Zimmerman JE, Knaus WA, Wagner DP, Sun X, Hakim RB, Nystrom PO. A comparison of risks and outcomes for patients with organ system failure: 1982–1990. *Crit Care Med* 1996; **24**: 1633–1641.

Key message

The number and duration of acute organ failures are strongly correlated with short-term mortality.

Why it's important

This paper was a key incentive for generic, as opposed to disease-specific, physiology-based severity scoring systems. This paper also fueled a conceptual model of care in the ICU.

Strengths

Profound observations that had a major impact on severity scoring, and on how care was organized and delivered in the ICU.

Weaknesses

No rigorous statistical modeling. No critical evaluation of the degree of organ failure or comparison across organ systems.

Relevance

The relationship of organ failure to outcome is an extremely important concept in modern ICU care.

Number of OSF		Day of failure						
		1st	2nd	3rd	4th	5th	6th	7th
1	Percent mortality*	22%	31%	34%	35%	40%	42%	41%
	No. deaths	450	261	204	159	142	118	80
	No. patients	2070	847	607	455	356	279	195
2	Percent mortality*	52%	67%	66%	62%	56%	64%	68%
	No. deaths	239	147	103	118	96	78	56
	No. patients	458	219	156	191	171	122	82
≥3	Percent mortality*	80%	95%	93%	96%	100%†	100%†	100%†
	No. deaths	152	70	50	50	38	33	32
	No. patients	191	74	54	52	38	33	32

Fig. 18-2. Hospital mortality according to number and duration of organ system failure (OSF) for 2719 OSF admissions to 13 hospitals *To calculate confidence level: 95% confidence level (± 2 standard deviations [SD]). One SD = NPQ ; N = total number; P = percent death rate; $Q = 1 - P$. For a patient with ≥ 3 OSFs on the fourth day of OSF, $N = 52$, $P = 0.96$, $Q = 0.04$; therefore, $1 \text{ SD} = 1.4/52 = 2.7\%$, so $\pm 2 \text{ SD} = 96\% \pm 5.4\%$. Therefore, the next patient to have ≥ 3 OSFs on the fourth day of OSFs has a projected death rate of 90.6–100%. (Use of Poisson distribution yields equivalent results.) †Survival unprecedented with maximum statistical probability of survival of 10% (with 95% confidence). (Adapted from Knaus et al. *Ann Surg* 1985; 202: 685–693.)

Title

APACHE II: a severity of disease classification system

Author

Knaus WA, Draper EA, Wagner DP, Zimmerman JE

Reference

Crit Care Med 1985; **13**: 818–829

Abstract

This paper presents the form and validation results of APACHE II, a severity of disease classification system. APACHE II uses a point score based upon initial values of 12 routine physiologic measurements, age, and previous health status, to provide a general measure of severity of disease. An increasing score (range 0 to 71) was closely correlated with the subsequent risk of hospital death for 5815 intensive care admissions from 13 hospitals. This relationship was also found for many common diseases. When APACHE II scores are combined with an accurate description of disease, they can prognostically stratify acutely ill patients, and assist investigators comparing the success of new or differing forms of therapy. This scoring index can be used to evaluate the use of hospital resources, and compare the efficacy of intensive care in different hospitals, or over time.

Summary

In the mid-1980s, 13 hospitals agreed to collect data on a variety of patient characteristics, including several physiological variables recorded as their worst value on the first day of ICU admission. The authors developed a logistic regression model using these variables that accurately predicted hospital mortality across bands of risk, and across different disease groups (see Figure). APACHE II went on to become the most widely used severity adjustment system in critical care.

Citation count 4493

Related references

1. Knaus WA, Zimmerman JE, Wagner DP, Draper EA, Lawrence DE. APACHE – acute physiology and chronic health evaluation: a physiologically based classification system. *Crit Care Med* 1981; **9**: 591–597.
2. Knaus WA, Wagner DP, Draper EA *et al*. The APACHE III prognostic system. Risk prediction of hospital mortality for critically ill hospitalized adults. *Chest* 1991; **100**: 1619–1636.

Key message

Hospital mortality can be accurately predicted using a simple scoring system that awards points based on physiological derangement on the first day of ICU care, together with age and chronic health evaluation.

Why it's important

The most widely quoted, unequivocal demonstration that a generic, non-disease-specific system reflecting physiological derangement drives a patient's subsequent short-term risk of death.

Strengths

Multi-center dataset; robust statistical analysis; excellent model performance.

Weaknesses

US hospitals only, and these hospitals were not necessarily representative of US ICU delivery. Variable selection not based on statistical precision. Reporting of model performance less than ideal, given current demands for explicit reporting of model calibration, and no separate development and validation cohorts.

Relevance

One of the most quoted critical care papers of all time. Perhaps the classic paper of intensive care. APACHE II is still used all over the world.

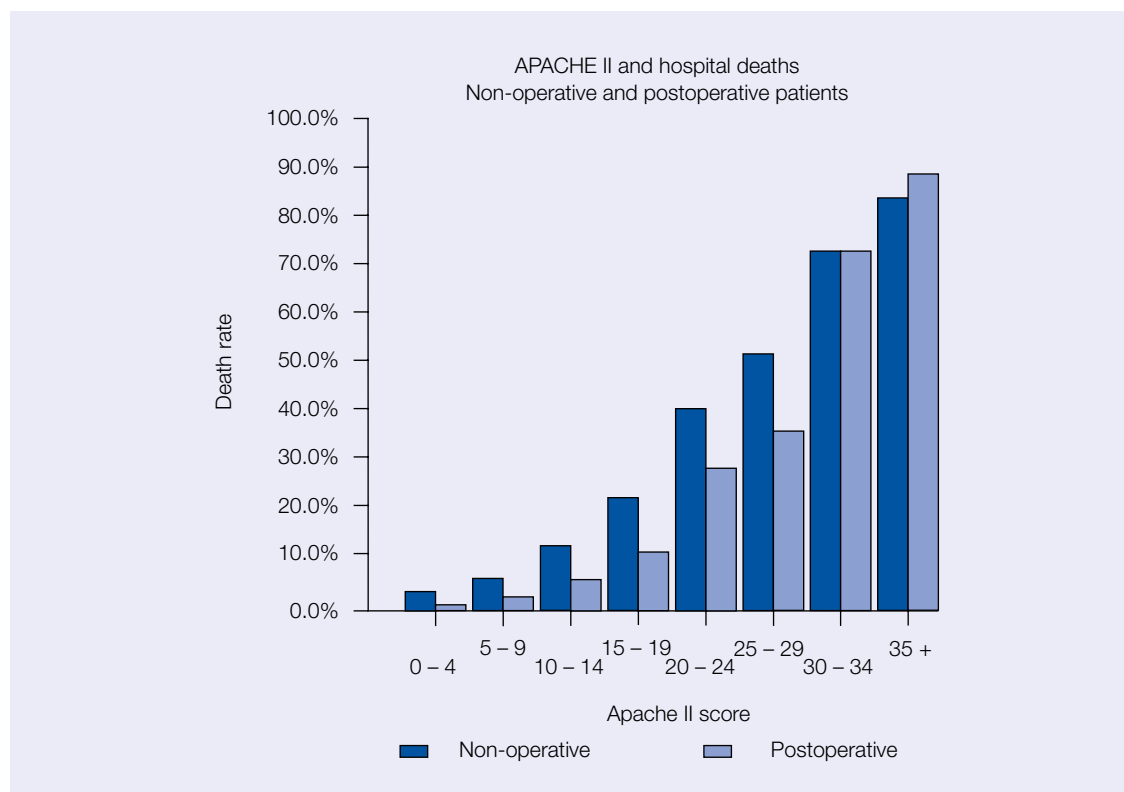

Fig. 18-3. The relationship between APACHE II scores and hospital mortality among 5815 ICU admissions (Adapted from Knaus WA et al. *Crit Care Med* 1985; 13: 818-829.)

Title

Pediatric risk of mortality (PRISM) score

Author

Pollack MM, Ruttimann UE, Getson PR

Reference

Crit Care Med 1988; **16**: 1110–1116

Abstract

The Pediatric Risk of Mortality (PRISM) score was developed from the Physiologic Stability Index (PSI) to reduce the number of physiologic variables required for pediatric ICU (PICU) mortality risk assessment, and to obtain an objective weighting of the remaining variables. Univariate and multivariate statistical techniques were applied to admission day PSI data (1,415 patients, 116 deaths) from four PICUs. The resulting PRISM score consists of 14 routinely measured, physiologic variables, and 23 variable ranges. The performance of a logistic function estimating PICU mortality risk from the PRISM score, age, and operative status was tested in a different sample from six PICUs (1,227 patients, 105 deaths), each PICU separately, and in diagnostic groups using chi-square goodness-of-fit tests, and receiver operating characteristic (ROC) analysis. In all groups, the number and distribution of survivors and nonsurvivors in adjacent mortality risk intervals were accurately predicted: total validation group ($\chi^2(5) = 0.80$; $p > 0.95$), each PICU separately ($\chi^2(5)$ range 0.83 to 7.38; all $p > 0.10$), operative patients ($\chi^2(5) = 2.03$; $p > 0.75$), nonoperative patients ($\chi^2(5) = 2.80$, $p > 0.50$), cardiovascular disease patients ($\chi^2(5) = 4.72$; $p > 0.25$), respiratory disease patients ($\chi^2(5) = 5.82$; $p > 0.25$), and neurologic disease patients ($\chi^2(5) = 7.15$; $p > 0.10$). ROC analysis also demonstrated excellent predictor performance (area index = 0.92 \pm 0.02).

Summary

This severity scoring system, PRISM, is the most important and widely used severity scoring system in children. The model has excellent performance characteristics, arguably superior to similar adult systems (see Figure 18-4). Like its adult counterparts, it relies heavily on physiological derangement. The model was developed on 1415 patients in four ICUs, and validated on 1227 patients in a different set of six ICUs.

Citation count 510

Related references

1. Pollack MM, Patel KM, Ruttimann UE. PRISM III: an updated Pediatric Risk of Mortality score. *Crit Care Med* 1996; **24**: 743–752.

Key message

Hospital mortality can be accurately predicted for critically ill children using ICU admission physiological variables.

Why it's important

Major scoring system in children.

Strengths

Excellent methodological rigor.

Weaknesses

Patients were only accrued from four ICUs, and tested in another six. A larger and potentially more generalizable set of ICUs would have been a welcome addition to the study.

Relevance

Highly relevant for all pediatric critical care.

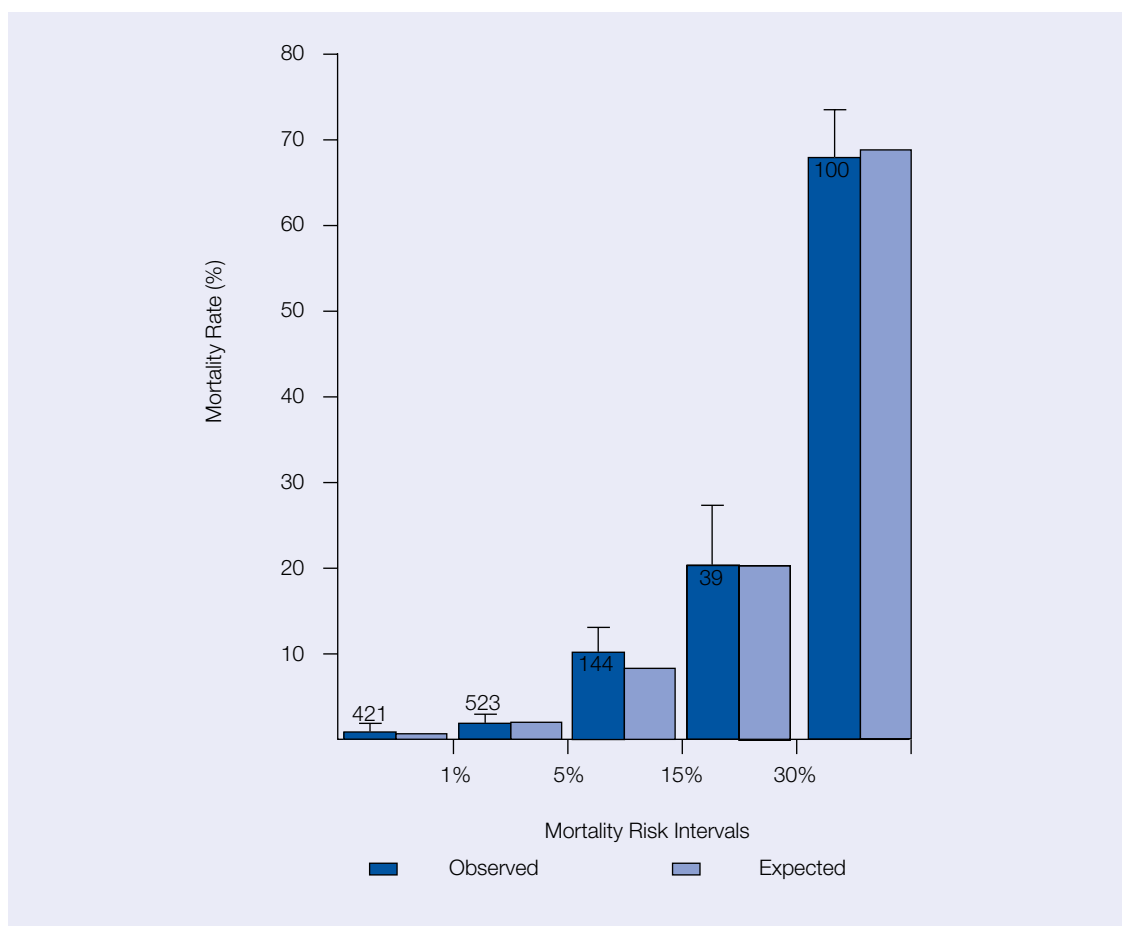

Fig. 18-4. Comparison of the observed and expected (based on the PRISM score) mortality rates in five severity of illness strata from the validation group. The number of patients in each mortality risk group is shown as insets. The predicted outcomes were not different from the expected outcomes ($\chi^2(5) = 0.80, p > 0.95$) (Adapted from Pollack MM et al. *Crit Care Med* 1988; 16: 1110–1116.)

Title

Therapeutic Intervention Scoring System: update 1983

Author

Keene AR, Cullen DJ

Reference

Crit Care Med 1983; **11**: 1–3

Abstract

The Therapeutic Intervention Scoring System (TISS) introduced in 1974 has become a widely accepted method of classifying critically ill patients. In response to requests to update the system because of recent innovations in critical care, some items have been deleted, some have been added, and certain point scores have been adjusted (see Table 18-1). Explanations of items within the system and guidelines for the user are included. A comparison of the new 1983 system to the old 1974 system in 100 consecutive patients reveals no difference in total point scores. We hope this updated explanation will ease the task of assessing use of intensive care services.

Summary

Unlike other scoring systems, TISS does not attempt to quantify a patient's severity of illness. Rather, it quantifies the intensity of care provided to an intensive care patient. It awards points to different activities, with more points for more time-consuming or complex tasks. As such, it is a proxy for resource use and, to a lesser degree, nursing requirements. A key advantage of TISS is that it can be applied in different countries. In addition, it is a measure of resource use that has considerable clinical validity, as it is based on discrete clinical tasks, as opposed to other measures such as hospital billing records, whose relation to clinical care can sometimes appear remote. TISS was first reported in 1974, but updated in 1983 to reflect changes in practice. This paper reports the most widely used version of TISS. There are now newer versions, including a shorter instrument, and an instrument that focuses only on 'active' activities that can only be practically performed in the ICU. TISS has also been adapted as a measure of resource use on the hospital ward.

Citation count 451

Related references

1. Cullen DJ, Civetta JM, Briggs BA, Ferrara LC. Therapeutic intervention scoring system: a method for quantitative comparison of patient care. *Crit Care Med* 1974; **2**: 57–60.
2. Cullen DJ, Nemeskal AR, Zaslavsky AM. Intermediate TISS: a new Therapeutic Intervention Scoring System for non-ICU patients. *Crit Care Med* 1994; **22**: 1406–1411.
3. Miranda DR, de Rijk A, Schaufeli W. Simplified Therapeutic Intervention Scoring System: the TISS-28 items – results from a multicenter study. *Crit Care Med* 1996; **24**: 64–73.

Key message

Resource use can be monitored using a simple scoring system.

Why it's important

Tracking resource use in health care is both important and complex. TISS is a simple, reliable, effective, and international scoring system.

Strengths

Simplicity and ease-of-use, clinically sensible.

Weaknesses

Weighting of tasks with points not calibrated. Cost per TISS point must still be calculated for each country or health system. Nursing workload not necessarily accurately reflected. Indirect costs and fixed costs not included. Several versions now available without clear distinction of the advantages and disadvantages of one over any other.

Relevance

Still a key tool for tracking ICU resource use.

Table 18-1. Therapeutic Intervention Scoring System – 1983

4 Points	2 Points
a. Cardiac arrest and/or countershock within past 48 h*	a. CVP (central venous pressure)
b. Controlled ventilation with or without PEEP*	b. 2 peripheral iv catheters
c. Controlled ventilation with intermittent or continuous muscle relaxants*	c. Hemodialysis – stable patient
d. Balloon tamponade of varices*	d. Fresh tracheostomy (<48 h)
e. Continuous arterial infusion*	e. Spontaneous respiration via endotracheal tube or tracheostomy (T-piece or trach mask)
f. Pulmonary artery catheter	f. GI feeding
g. Atrial and/or ventricular pacing*	g. Replacement of excess fluid loss*
h. Hemodialysis in unstable patient*	h. Parenteral chemotherapy
i. Peritoneal dialysis	i. Hourly neuro vital signs
j. Induced hypothermia*	j. Multiple dressing changes
k. Pressure-activated blood infusion*	k. Pitressin infusion iv
l. G-suit	
m. Intracranial pressure monitoring	
n. Platelet transfusion	
o. IABA (intra-aortic balloon assist)	
p. Emergency operative procedures (within past 24 h)*	
q. Lavage of acute GI bleeding	
r. Emergency endoscopy or bronchoscopy	
s. Vasoactive drug infusion (>1 drug)	
3 Points	1 Point
a. Central iv hyperalimentation (includes renal, cardiac, hepatic failure fluid)	a. ECG monitoring
b. Pacemaker on standby	b. Hourly vital signs
c. Chest tubes	c. 1 peripheral iv catheter
d. Intermittent mandatory ventilation (IMV) or assisted ventilation	d. Chronic anticoagulation
e. Continuous positive airway pressure (CPAP)	e. Standard intake and output (q 24 h)
f. Concentrated K ⁺ infusion via central catheter	f. STAT blood tests
g. Nasotracheal or orotracheal intubation*	g. Intermittent scheduled iv medications
h. Blind intracheal suctioning	h. Routine dressing changes
i. Complex metabolic balance (frequent intake and output)*	i. Standard orthopedic traction
j. Multiple ABG, bleeding and/or STAT studies (>4/shift)	j. Tracheostomy care
k. Frequent infusions of blood products (>5 units/24 h)	k. Decubitus ulcer*
l. Bolus iv medications (non-scheduled)	l. Urinary catheter
m. Vasoactive drug infusion (1 drug)	m. Supplemental oxygen (nasal or mask)
n. Continuous anti-arrhythmia infusions	n. Antibiotics iv (2 or less)

3 Points	1 Point
o. Cardioversion for arrhythmia (not defibrillation)	o. Chest physiotherapy
p. Hypothermia blanket	p. Extensive irrigations, packings or debridement of wound, fistula or colostomy
q. Arterial line	q. GI decompression
r. Acute digitalization – within 48 h	r. Peripheral hyperalimentation/intralipid therapy
s. Measurement of cardiac output by any method	
t. Active diuresis for fluid overload or cerebral edema	
u. Active Rx for metabolic alkalosis	
v. Active Rx for metabolic acidosis	
w. Emergency thora-, para- and peri-cardiocenteses	
x. Active anticoagulation (initial 48 h)*	
y. Phlebotomy for volume overload	
z. Coverage with >2 iv antibiotics	
aa. Rx of seizures or metabolic encephalopathy (within 48 h of onset)	
bb. Complicated orthopedic traction*	

*Therapeutic Intervention Scoring System explanation code:

4-Point Interventions: (a) Point score for 2 days after most recent cardiac arrest. (b) This does not mean intermittent mandatory ventilation, which is a 3-point intervention. It does mean that regardless of the internal plumbing of the ventilator, the patient's full ventilatory needs are being supplied by the machine. Whether or not the patient is ineffectively breathing around the ventilator is irrelevant as long as the ventilator is providing all the patient's needed minute ventilation. (c) For example, D-tubocurarine chloride, pancuronium (Pavulon), metocurine (Metubine). (d) Use Sengstaken-Blakemore or Linton tube for esophageal or gastric bleeding. (e) Pitressin infusion via IMA, SMA, gastric artery catheters for control of gastrointestinal bleeding, or other intra-arterial infusion. This does not include standard 3 ml/h heparin flush to maintain catheter patency. (g) Active pacing even if a chronic pacemaker. (h) Include first 2 runs of an acute dialysis. Include chronic dialysis in patient whose medical situation now renders dialysis unstable. (j) Continuous or intermittent cooling to achieve body temperature <33°C. (k) Use of a blood pump or manual pumping of blood in the patient who requires rapid blood replacement. (p) May even be the initial emergency operative procedure – precludes diagnostic tests, e.g. angiography, CT scan.

3-Point Interventions: (d) The patient is supplying some of his own ventilatory needs. (g) Not a daily point score. Patient must have been intubated in the ICU (elective or emergency) within previous 24 h. (i) Measurement of intake/output above and beyond the normal 24-h routine. Frequent adjustment of intake according to total output. (x) Includes Rheomacrodex. (bb) For example, Stryker frame, CircOlectric.

2-Point Interventions: (g) Replacement of clear fluids over and above the ordered maintenance level.

1-Point Interventions: (k) Must have a decubitus ulcer. Does not include preventive therapy.

Title***Mortality Probability Models (MPM II) based on an international cohort of intensive care unit patients***

Author

Lemeshow S, Teres D, Klar J, Avrunin JS, Gehlbach SH, Rapoport J

ReferenceJAMA 1993; **270**: 2478–2486

Abstract

OBJECTIVE: To revise and update models in the Mortality Probability Model (MPM II) system to estimate the probability of hospital mortality among 19,124 intensive care unit (ICU) patients that can be used for quality assessment within and among ICUs. **DESIGN AND SETTING:** Models developed and validated on consecutive admissions to adult medical and surgical ICUs in 12 countries. **PATIENTS:** A total of 12,610 patients for model development, and 6514 patients for model validation. Patients younger than 18 years, and burn, coronary care, and cardiac surgery patients were excluded. **OUTCOME MEASURE:** Vital status at hospital discharge. **RESULTS:** The admission model, MPM0, contains 15 readily obtainable variables. In developmental and validation samples, it calibrated well (goodness-of-fit tests: $p = 0.623$ and $p = 0.327$, respectively, where a high p value represents good fit between observed and expected values), and discriminated well (area under the receiver operating characteristic curve = 0.837 and 0.824, respectively). The 24-hour model, MPM24 (developed on 10,357 patients still in the ICU at 24 hours), contains five of the admission variables, and eight additional variables easily ascertained at 24 hours. It also calibrated well ($p = 0.764$ and $p = 0.231$ in the developmental and validation samples, respectively), and discriminated well (area under the receiver operating characteristic curve = 0.844 and 0.836 in the developmental and validation samples, respectively). **CONCLUSIONS:** Among severity systems for intensive care patients, the MPM0 is the only model available for use at ICU admission. Both MPM0 and MPM24 are useful research tools, and provide important clinical information when used alone or together.

Summary

MPM II, the second version of MPM, was developed from an observational outcomes study of 19,124 ICU patients enrolled across 12 countries in North America and Europe. The authors conducted an extremely rigorous study that involved careful variable selection, using both clinical sensibility and statistical precision. The variables were then entered into a logistic regression model built on one random half of the cohort. Once satisfied that they had a robust model, the authors tested their model on the other half (validation cohort). The authors provided a clear report of all methodological steps, and detailed reporting of the calibration and discrimination of their model.

Citation count

398

Related references

1. Lemeshow S, Teres D, Pastides H, Avrunin JS, Steingrub JS. A method for predicting survival and mortality of ICU patients using objectively derived weights. *Crit Care Med* 1985; **13**: 519–525.
2. Le Gall JR, Lemeshow S, Saulnier F. A new Simplified Acute Physiology Score (SAPS II) based on a European/North American multicenter study. *JAMA* 1993; **270**: 2957–2963.

Key message

MPM II is a robust, validated hospital mortality prediction model that provides an immediate probability of death based on commonly used variables available at the time of ICU admission.

Why it's important

MPM II, in distinction to APACHE II or III, does not require 24 hours of ICU care before a score can be generated. Rather, it uses data available at the time of admission. This offers the theoretical advantage that it could be used as an ICU admission decision tool. MPM II also gives a direct probability of death, rather than a score, as its output. APACHE provides a score that must be entered into an equation to generate a probability of death, and the latest version of that equation (APACHE III risk equation) is proprietary.

Strengths

An elegant paper with careful and explicit reporting of a sophisticated and rigorous observational study and statistical analysis. MPM II can be calculated at ICU admission. Reported performance appears comparable to that of APACHE III. Multinational database used to develop score.

Weaknesses

Elements in the MPM II score, such as do not resuscitate status, may contribute highly to risk of death, yet may be used variably in different health care systems. However, this paper is well written, the conceptual model is strong, the execution robust, and weaknesses are few.

Relevance

MPM II is one of the most widely used generic scoring systems in critical care today.

Title

Improving the outcomes of coronary artery bypass surgery in New York State

Author

Hannan EL, Kilburn H Jr, Racz M, Shields E, Chassin MR

Reference

JAMA 1994; **271**: 761–766

Abstract

OBJECTIVE: To assess changes in outcomes of coronary artery bypass graft (CABG) surgery in New York since 1989, when the State Department of Health began collecting, analyzing, and disseminating information regarding risk factors, mortality, and complications of CABG surgery. These new data stimulated specific quality improvement activities at hospitals throughout the state. **DESIGN:** A clinical database was used to identify significant independent risk factors, and to assess risk-adjusted provider mortality rates. **SETTING:** All 30 hospitals performing CABG surgery in New York during the period 1989 through 1992. **PATIENTS:** All 57,187 patients undergoing isolated CABG surgery who were discharged from New York State hospitals in 1989 through 1992. **MAIN OUTCOME MEASURES:** Actual, expected (from a logistic regression model), and risk-adjusted in-hospital mortality. **RESULTS:** Actual mortality decreased from 3.52% in 1989 to 2.78% in 1992. Because average patient severity of illness increased, risk-adjusted mortality decreased even more – a decrease of 41%, from 4.17% in 1989 to 2.45% in 1992. The risk-adjustment model performed well; there were no clinically or statistically significant differences between actual and predicted numbers of deaths at any of 10 levels of patient severity. **CONCLUSIONS:** We believe that this quality improvement program, based on the collection and dissemination of risk-adjusted mortality data for CABG surgery, played a significant role in the observed decline in the death rate from this procedure. Quality improvement programs based on similar principles for other procedures and conditions should be undertaken.

Summary

The New York State Health Board was one of the leading institutions in the early 1990s proposing that the systematic collection and reporting of severity-adjusted outcomes would result in improved patient outcomes. Although limited to patients undergoing coronary artery bypass surgery (CABG), the implications for critical care are obvious. NY mandated that all hospitals collect baseline clinical data. These data were entered into a CABG-specific short-term mortality prediction model to generate an expected mortality rate for each hospital. The standardized mortality ratio (SMR) (observed/expected mortality) was quoted regularly in the local media, with subsequent consumer pressure on hospitals with poor SMRs. In this paper, the authors demonstrated that severity-adjusted mortality fell over a 4-year period. They contend that this was a direct result of efforts at the institutional level to examine poor outcomes and improve care. Whether the observed decline in mortality was truly due to this reporting process is both unclear and controversial. Nevertheless, this represented arguably the first and most widely quoted state-wide quality improvement initiative using severity scoring systems.

Citation count

440

Related references

1. Landon B, Iezzoni LI, Ash AS *et al.* Judging hospitals by severity-adjusted mortality rates: the case of CABG surgery. *Inquiry* 1996; **33**: 155–166.
2. Tu JV, Naylor CD. Coronary artery bypass mortality rates in Ontario. A Canadian approach to quality assurance in cardiac surgery. Steering Committee of the Provincial Adult Cardiac Care Network of Ontario. *Circulation* 1996; **94**: 2429–2433.
3. Sirio CA, Shepardson LB, Rotondi AJ *et al.* Community-wide assessment of intensive care outcomes using a physiologically based prognostic measure: implications for critical care delivery from Cleveland Health Quality Choice. *Chest* 1999; **115**: 793–801.

Key message

Public reporting of severity-adjusted institutional outcomes can improve quality of care.

Why it's important

This paper reported on the first major quality assurance project of this scale that used severity scoring at the heart of its intervention.

Strengths

State-wide initiative. Excellent example of government-driven quality improvement initiative.

Weaknesses

Unclear if the decrease in mortality was actually due to public reporting of outcomes, or coincidental.

Relevance

Highly relevant for similar efforts to report ICU severity-adjusted outcome performance.

Title

A controlled trial to improve care for seriously ill hospitalized patients: the Study to Understand Prognoses and Preferences for Outcomes and Risks of Treatments (SUPPORT)

Author

Knaus WA, Connors AF, Dawson NV *et al.* SUPPORT Principal Investigators

Reference

JAMA 1995; **274**: 1591–1598

Abstract

OBJECTIVES: To improve end-of-life decision making and reduce the frequency of a mechanically supported, painful, and prolonged process of dying. **DESIGN:** A 2-year prospective observational study (phase I) with 4301 patients, followed by a 2-year controlled clinical trial (phase II) with 4804 patients and their physicians randomized by specialty group to the intervention group ($n = 2652$), or control group ($n = 2152$). **SETTING:** Five teaching hospitals in the United States. **PATIENTS:** A total of 9105 adults hospitalized with one or more of nine life-threatening diagnoses; an overall 6-month mortality rate of 47%. **INTERVENTION:** Physicians in the intervention group received estimates of the likelihood of 6-month survival for every day up to 6 months, outcomes of cardiopulmonary resuscitation (CPR), and functional disability at 2 months. A specifically trained nurse had multiple contacts with the patient, family, physician, and hospital staff to elicit preferences, improve understanding of outcomes, encourage attention to pain control, and facilitate advance care planning and patient-physician communication. **RESULTS:** The phase I observation documented shortcomings in communication, frequency of aggressive treatment, and the characteristics of hospital death: only 47% of physicians knew when their patients preferred to avoid CPR; 46% of do-not-resuscitate (DNR) orders were written within 2 days of death; 38% of patients who died spent at least 10 days in an intensive care unit (ICU); and for 50% of conscious patients who died in the hospital, family members reported moderate to severe pain at least half the time. During the phase II intervention, patients experienced no improvement in patient-physician communication (eg, 37% of control patients and 40% of intervention patients discussed CPR preferences), or in the five targeted outcomes, ie, incidence or timing of written DNR orders (adjusted ratio, 1.02; 95% confidence interval [CI], 0.90 to 1.15), physicians' knowledge of their patients' preferences not to be resuscitated (adjusted ratio, 1.22; 95% CI, 0.99 to 1.49), number of days spent in an ICU, receiving mechanical ventilation, or comatose before death (adjusted ratio, 0.97; 95% CI, 0.87 to 1.07), or level of reported pain (adjusted ratio, 1.15; 95% CI, 1.00 to 1.33). The intervention also did not reduce use of hospital resources (adjusted ratio, 1.05; 95% CI, 0.99 to 1.12).

CONCLUSIONS: The phase I observation of SUPPORT confirmed substantial shortcomings in care for seriously ill hospitalized adults. The phase II intervention failed to improve care or patient outcomes. Enhancing opportunities for more patient-physician communication, although advocated as the major method for improving patient outcomes, may be inadequate to change established practices. To improve the experience of seriously ill and dying patients, greater individual and societal commitment, and more proactive and forceful measures may be needed.

Summary

The SUPPORT trial was one of the most expensive and logistically complex randomized interventional trials in the history of critical care, and arguably in medicine. A key element of this study was the use of objective risk estimates generated from APACHE III to guide care decisions. Physicians were provided with prospective estimates in an attempt to help them engage in decisions with families to withdraw support in patients for whom further care was deemed futile. Unfortunately, the trial failed to demonstrate that such objective estimates impacted physician–patient/ family communication, or any other parts of care. The implications from this trial still remain to be untangled. With increasing use of advance directives, and consumer desire to be more empowered with information, the intuitive belief is that objective risk estimates would have a useful role in end-of-life care. Why SUPPORT failed, therefore, is unclear. One lesson, however, is that the incorporation of severity-score data in patient care will not be straightforward, and attempts to use the information to improve care will require careful consideration of the clinical decision-making process, including physician, patient and family bias and behaviour.

Citation count 1080

Related references

1. Knaus WA, Harrell FE Jr, Lynn J *et al.* The SUPPORT prognostic model. Objective estimates of survival for seriously ill hospitalized adults. Study to understand prognoses and preferences for outcomes and risks of treatments. *Ann Intern Med* 1995; **122**: 191–203.

Key message

The use of prognostic information did not obviously improve physician decision-making and end-of-life care in the ICU.

Why it's important

This study is important, if only to inform researchers and policy experts that improving end-of-life care may be more complex than first imagined.

Strengths

Rigorous multicenter study design.

Weaknesses

Intervention, although based on sophisticated risk prediction, was overly simplistic in its application.

Relevance

Using scoring systems prospectively to influence care and improve clinical decision-making has always been an important goal. This early failure does not mean that such systems cannot have a role in decision-making, but lessons learned from this trial will be key to future success.

Ethics

Charles L. Sprung MD

Introduction

The choice of the papers that have been included in this chapter was not easy. In general, I tried to include the first papers evaluating important ethical issues in critical care medicine. These included the issues of informed consent, patient and family preferences, rationing, withholding and withdrawing life-sustaining treatments, futility, brain death, and unethical procedures in patients.

Title

Ethics and clinical research

Author

Beecher HK

Reference

N Engl J Med 1966; **274**: 1354–1360

Abstract

Not available

Summary

The frequency of unethical procedures in clinical research was evaluated by the examination of 100 consecutive human studies published in 1964 in an excellent journal. In only 2 of 50 studies was consent mentioned. Examples from the 22 provided studies include:

1. *Known effective treatment withheld* – To determine the relapse rate of typhoid fever, 25 patients were treated with chloramphenicol, and 157 received symptomatic treatment without chloramphenicol (mortality – 8% versus 23% respectively).
2. *Study of therapy* – To evaluate hepatic dysfunction from therapy with triacetyloleandomycin, 50 patients including mentally impaired subjects or juvenile delinquents treated for acne were studied. By the time half the patients had received the drug for 4 weeks, the high incidence of significant hepatic dysfunction led to its discontinuation in the remainder of the group.
3. *Physiological studies* – A controlled, double-blind study to further define the hematological toxicity of chloramphenicol by randomly giving 2 or 6 g of chloramphenicol daily. Toxic bone marrow depression developed in 2 of 20 patients given 2 g, and 18 of 21 patients given 6 g daily.
4. *Studies to improve the understanding of disease* – Liver cancer cells were injected into 22 human subjects as part of a study of immunity to cancer. Subjects were told they were receiving 'some cells', but the word cancer was not mentioned.
5. *Technical study of disease* – The transbronchial approach for left heart catheterization was developed as a new approach in >500 cases; 15 patients had normal hearts and underwent bronchoscopy for other reasons.

Unethical or questionably ethical procedures involving risks to the health or life of subjects are not uncommon. Thoughtlessness and carelessness, not a willful disregard of the patient's rights, account for most of the cases. These types of activities will do great harm to medicine unless soon corrected. Data obtained unethically should not be published, or should be published with a stern editorial comment. Serious attention to this problem is urgently required.

Citation count

535

Related references

1. Freedman B. Equipoise and the ethics of clinical research. *N Engl J Med* 1987; **317**: 141–145.
2. Hellman S, Hellman DS. Of mice but not men. Problems of the randomized clinical trial. *N Engl J Med* 1991; **324**: 1585–1589.
3. Biros MH, Fish SS, Lewis RJ. Implementing the Food and Drug Administrations' final rule for waiver of informed consent in certain emergency research circumstances. *Acad Emerg Med* 1999; **6**: 1272–1282.

Key message

Unethical or questionably ethical procedures have been performed on human subjects and published in a prestigious medical journal.

Why it's important

This was the first major acknowledgment by American medicine after the Nuremberg trials that unethical behaviour was present in clinical research in the USA. Subsequent to this revelation, steps were taken to remedy the situation.

Strengths

A well-known clinician served as a whistle blower to prevent further harm to medicine because of unethical procedures in research.

Weaknesses

Individuals and references were not cited.

Relevance

Clinical research is extremely difficult to perform in the critically ill. One must always be certain that ethical standards are followed.

Title

Informed consent in theory and practice: legal and medical perspectives on the informed consent doctrine and a proposed reconceptualization

Author

Sprung CL, Winick BJ

Reference

Crit Care Med 1989; **17**: 1346–1354

Abstract

The theoretical, legal, and medical doctrines of informed consent are analyzed. The elements of informed consent include disclosure of information, competency, understanding, voluntariness, and decision-making. The doctrine is ground in deference to individual autonomy, and recognition that the exercise of self-determination in matters of health is a liberty interest honored by our history and traditions.

The exceptions to informed consent, including emergency, incompetency, therapeutic privilege, and waiver, are especially important in critically ill patients, and reflect a balancing of autonomy values and society's interest in the promotion of health. Legal decisions inevitably are based on atypical physician-patient encounters and focus on a particular problem or procedure rather than on overall medical care. In addition, they often reflect an artificial view of the doctor-patient relationship. Medical decision-making is a complex, evolving pursuit of a diagnosis and proper treatment regimen. Moreover, patients are not always interested in the role assigned to them by law. A reconceptualization of informed consent doctrines utilizing sliding scale standards based on variables pertinent to each individual patient is suggested.

Citation count 50

Related references

1. Ingelfinger FJ. Informed (but uneducated) consent. *N Engl J Med* 1972; **287**: 465–466.
2. President's Commission for the Study of Ethical Problems in Medicine and Biomedical and Behavioral Research. *Making Health Care Decisions: The Ethical and Legal Implications of Informed Consent in the Patient-Practitioner Relationship*, Vol 1. Washington, DC: Government Printing Office, 1982.
3. Biros MH, Fish SS, Lewis RJ. Implementing the Food and Drug Administration's final rule of waiver of informed consent in certain emergency research circumstances. *Acad Emerg Med* 1999; **6**: 1272–1282.
4. Ethics of the European Society of Intensive Care Medicine. Informed consent for research purposes in intensive care patients in Europe. *Intensive Care Med* 1997; **23**: 338–341, 435–439.

Key message

Physicians should view informed consent as a balance between the conflicting goals of individual self-determinism and health.

Why it's important

The first review of the theoretical, legal, and medical doctrines of informed consent, with special emphasis on critically ill patients.

Strengths

A review stating the legal requirements and exceptions to informed consent, together with the medical realities of the process.

A practical reconceptualization of informed consent utilizing sliding scale standards based on variables pertinent to each individual patient is suggested.

Weaknesses

A review, rather than objective, empirical data. An American, rather than worldwide, perspective.

Relevance

Informed consent is an extremely important issue in critically ill patients who are often incompetent and require emergency procedures and treatments.

Title

Rationing intensive care – physician responses to a resource shortage

Author

Singer DE, Carr PL, Mulley AG, Thibault GE

Reference

N Engl J Med 1983; **309**: 1155–1160

Abstract

To determine how physicians ration limited critical resources, we studied the allocation of intensive care unit (ICU) beds during a shortage caused by a lack of nurses. As the bed capacity of the medical ICU decreased from 18 to 8, the percentage of days on which one or more beds were available decreased from 95 to 55 per cent, and monthly admissions decreased from 122 to 95.

Physicians responded by restricting ICU admissions to acutely ill patients and reducing the proportion of patients admitted primarily for monitoring. Among patients admitted because of chest pain, the proportion actually sustaining a myocardial infarction increased linearly with the restriction in bed capacity. Although more patients with myocardial infarction were admitted to non-intensive care areas, there was no increase in mortality. In addition, physicians transferred patients out of the ICU sooner. There was no apparent withdrawal of care from dying patients.

Our results suggest that physicians can respond to moderate resource limitations by more efficient use of intensive care resources.

Summary

Physician triage decisions were compared between July to December 1980 (baseline period with 18 ICU beds), and July to December 1981 (decreased ICU bed capacity with 8–14 beds due to a nursing shortage). The medical intensive care and coronary care unit (ICU) occupancy rate increased from 77% to 90%, whereas bed availability decreased from 95% to 55%. The number of ICU admissions decreased, and the admitted patients had a greater severity of illness, as measured by major interventions per patient and the rate of confirmed myocardial infarctions. Although more patients were admitted directly to the wards with chest pain, and more patients were subsequently transferred from the ward to the ICU with chest pain, there were no significant mortality differences between the years. In addition to maintaining stricter criteria for ICU admission, patients were transferred out of the ICU after shorter lengths of stay. This was especially true for those patients admitted for monitoring. There was no difference in ICU length of stay for those patients eventually dying in the hospital, suggesting that withdrawal of care from dying patients did not increase for triage purposes.

Citation count 142

Related references

1. Engelhardt HT, Rie MA. Intensive care units, scarce resources, and conflicting principles of justice. *JAMA* 1986; **255**: 1159–1164.

2. Kalb PE, Miller DH. Utilization strategies for intensive care units. *JAMA* 1989; **261**: 2389–2395.
3. Sprung CL, Geber D, Eidelman LA *et al.* Evaluation of triage decisions for intensive care admission. *Crit Care Med* 1999; **27**: 1073–1079.
4. Society of Critical Care Medicine Ethics Committee. Attitudes of critical care medicine professionals concerning distribution of intensive care resources. *Crit Care Med* 1994; **22**: 358–362.
5. President's Commission for the Study of Ethical Problems in Medicine and Behavioral Research. *Securing Access to Health Care*. Washington, DC: US Government Printing Office, 1983.
6. Society of Critical Care Medicine Ethics Committee. Consensus statement on the triage of critically ill patients. *JAMA* 1994; **271**: 1200–1203.
7. American Thoracic Society. Fair allocation of intensive care unit resources. *Am J Respir Crit Care Med* 1997; **156**: 1282–1301.

Key message

Physicians can respond to moderate resource limitations by more efficient use of ICU resources by restricting admissions to more severely ill patients, decreasing the proportion of patients primarily admitted for monitoring, and transferring patients out of the ICU sooner.

Why it's important

This is the first systematic study of physician practices in triaging patients for ICU beds during a period of scarcity, and the effects of these decisions. The study emphasizes physicians' decreasing 'preload' and 'afterload' to triage patients for intensive care.

Strengths

Systematic evaluation of admission and discharge diagnoses, readmissions, ICU and hospital lengths of stay, ICU and hospital mortality rates, and number of major interventions before and during an ICU bed shortage.

Weaknesses

1. Evaluation of only medical intensive care and coronary care unit patients, rather than general or surgical ICU patients.
2. Evaluation of patients admitted to the ICU, rather than the total hospitalized patient population that required ICU.
3. Even at a time of shortage, the ICU operated with one or more available beds more than half the time. These results may not apply to an ICU that functions at capacity and has further bed shortages.

Relevance

ICU triage decisions are made daily in ICUs throughout the world. Objective criteria to define clearly which patients actually benefit from ICU care, and which are 'too sick' or 'too well' to benefit from ICU care, are not available.

Title

Patients' and families' preferences for medical intensive care

Author

Danis M, Patrick DL, Southerland LI, Green ML

Reference

JAMA 1988; **260**: 797–802

Abstract

Medical ethics suggest that life-sustaining treatment decisions should be made with consideration for patients' preferences and quality of life. Patients were interviewed who were at least 55 years old, and had experienced medical ICU at a university hospital during a one-year period, to determine their preferences regarding intensive care; family members were interviewed if the patient had died (n = 160). Seventy percent of patients and families were 100% willing to undergo intensive care again to achieve even one month of survival; 8% were completely unwilling to undergo intensive care to achieve any prolongation of survival. Preferences were poorly correlated with functional status or quality of life, and were not altered by life expectancy for 82% of respondents. Age, severity of critical illness, length of stay, and charges for intensive care did not influence willingness to undergo intensive care. These data suggest that personal preferences may conflict with any health policy that limits the allocation of intensive care based on age, function, or quality of life.

Summary

All patients aged ≥ 55 years who lived within a 95-km radius admitted to the medical or respiratory ICUs for at least 24 hours between 1 January and 31 December 1983 were studied. Patients or family members of those patients who were incompetent or who had died were later interviewed at home. Study criteria were met by 193 patients, and 160 (83%) of the patients (69) or family members (91) agreed to participate. Patients averaged two chronic organ diseases and one sickness-related dysfunction. Fifty-one (74% of the surviving patients) and 60 (67%) of the families were willing to undergo intensive care even for a period of 1 month's life prolongation. Preference for intensive care did not correlate with the patient's functional status or quality of life, age, length of stay, or APACHE II score. Patients (38%) and family members (41%) said they would not choose intensive care if they had no hope of recovery, they were only being kept alive by machines, they were in a vegetative state or severely neurologically impaired, or going to be too much trouble for the family.

Citation count 168

Related references

1. Danis M, Jerrity S, Southerland LI, Patrick DL. A comparison of patient, family and physician assessments of the value of medical intensive care. *Crit Care Med* 1998; **16**: 594–600.
2. Emanuel EJ, Emanuel LL. Proxy decision making for incompetent patients: an ethical and empirical analysis. *JAMA* 1992; **267**: 2067–2071.

3. Lo B, Rouse F, Dornbrand L. Family decision-making on trial. Who decides for incompetent patients? *N Engl J Med* 1990; **322**: 1228–1231.

Key message

Elderly patients previously hospitalized in the ICU or their representatives prefer to undergo ICU care again to minimally prolong life. Patients and families seem to value survival over functional status and perceived quality of life, if the patients' perceived quality of life is not too low.

Why it's important

This was the first study evaluating patient preferences for intensive care related to their perception of quality of life.

Strengths

1. Consecutively admitted elderly patients to an ICU over a period of a year.
2. The patient population is an elderly one, with underlying diseases in which these decisions are extremely pertinent.

Weaknesses

1. The study evaluates patients who have already experienced intensive care, and does not evaluate patient preferences before their ICU experience.
2. It is unclear whether the conclusions of this study relate to other types of ICU patients (e.g. surgical), or younger patients.

Relevance

The autonomous preferences of patients and families for intensive care despite minimal likelihood of benefit conflict with the limited scarce resource of ICU beds and the ability to provide equitable care to all patients requiring ICU care.

Title

Medical futility: its meaning and ethical implications

Author

Schneiderman LJ, Jecker NS, Jonsen AR

Reference

Ann Intern Med 1990; **112**: 949–954

Abstract

The notion of medical futility has quantitative and qualitative roots that offer a practical approach to its definition and application. Applying these traditions to contemporary medical practice, we propose that when physicians conclude (either through personal experience, experiences shared with colleagues, or consideration of published empiric data) that in the last 100 cases a medical treatment has been useless, they should regard that treatment as futile. If a treatment merely preserves permanent unconsciousness or cannot end dependence on intensive medical care, the treatment should be considered futile. Unlike decision analysis, which defines the expected gain from a treatment by the joint product of probability of success and utility of outcome, our definition of futility treats probability and utility as independent thresholds. Futility should be distinguished from such concepts as theoretical impossibility, such expressions as ‘uncommon’ or ‘rare,’ and emotional terms like ‘hopelessness.’ In judging futility, physicians must distinguish between an effect, which is limited to some part of the patient’s body, and a benefit, which appreciably improves the person as a whole. Treatment that fails to provide the latter, whether or not it achieves the former, is ‘futile.’ Although exceptions and cautions should be borne in mind, we submit that physicians can judge a treatment to be futile, and are entitled to withhold a procedure on this basis. In these cases, physicians should act in concert with other health care professionals, but need not obtain consent from patients or family members.

Summary

This is a theoretical and practical approach to the concept of futility, with specific standards to invoke futility. A treatment that does not improve the patient’s prognosis, comfort, well-being, or general state of health should be considered futile. Futility refers to the objective quality of an action, whereas hopelessness describes a subjective attitude. Futility may refer to an improbability or unlikelihood of an event happening (quantitative), or to the quality of the event that treatment would produce (qualitative). Futility describes any effort to achieve a result that is possible, but that reasoning or experience suggests is highly improbable, and that cannot be systematically produced. In judging futility, as in other matters, physicians should admit uncertainty rather than impose unsubstantiated claims of certainty. Specifically excluded from this concept of futility is medical care for patients for whom such care offers the opportunity to achieve life goals, however limited. Physicians’ duty to serve the best interests of the patient may require that exceptions to this approach be made under special circumstances.

Citation count

394

Related references

1. Younger SJ. Who defines futility? *JAMA* 1998; **260**: 2094–2095.
2. Truog RD, Brett AS, Frader J. The problem with futility. *N Engl J Med* 1992; **326**: 1560–1564.
3. Ethics Committee of the Society of Critical Care Medicine. Consensus statement of the Society of Critical Care Medicine's Ethics Committee regarding futile and other possibly inadvisable treatments. *Crit Care Med* 1997; **25**: 887–891.

Key message

Futility is a professional judgment that takes precedence over patient autonomy, and permits physicians to decide what is a medical benefit without patient approval.

Why it's important

This is the first paper addressing the issue of futility that attempted to objectify and provide a practical approach to its definition and application.

Strengths

The proposed approach compares reasonably well with ideas held by many physicians.

Weaknesses

1. The proposed selection of proportions of success is arbitrary.
2. Excluding patient input from assessments of qualitative futility excludes the possibility of offering an opportunity to achieve life goals, which the authors state is one of the exclusions from their concept of futility.
3. The proposal invites abuse, neglect, and a retreat to paternalism.

Relevance

Despite great advances in medical technology, many patients remain in intensive care units with little hope of survival, continued dependence on intensive care, or permanent unconsciousness. This paper provides a practical approach to these patients.

Title

Withholding and withdrawal of life support from the critically ill

Author

Smedira NG, Evans BH, Grais LS, Cohen NH, Lo B, Cooke M, Schechter WP, Fink C, Epstein-Jaffe E, May C, Luce JM

Reference

N Engl J Med 1990; **322**: 309–315

Abstract

We investigated decisions to withhold or withdraw life support from patients in the medical-surgical intensive care units (ICUs) at the Moffitt-Long Hospital of the University of California and San Francisco General Hospital, from July 1987 through June 1988.

Among 1719 patients admitted to the two ICUs, life support was withheld from 22 (1%), and withdrawn from 93 (5%). The reason for limiting care was poor prognosis. Of these 115 patients (18 of whom were considered brain-dead), 89 died in the ICU (accounting for 45% of all deaths there), and all but 1 of the remaining patients died after transfer from the ICU. Thirteen (11%) had earlier expressed the wish that their terminal care be limited, but this affected care in only four cases. Only 5 of the 115 patients made the actual decision to limit care; the others were incompetent at the time. Of the latter, 102 had families who participated in the decision; family members of the other 8 incompetent patients could not be found, and the decisions were made by physicians. Only 10 families initially disagreed with the recommendations to limit care, and they later agreed. The median duration of intensive care among the patients from whom life support was withheld or withdrawn was eight days at Moffitt-Long Hospital, and four days at San Francisco General, as compared with medians of three and one days, respectively, for other patients who died in the ICU.

We conclude that although life-sustaining care is withheld or withdrawn relatively infrequently from patients in the ICU, such decisions precipitate about half of all deaths in the ICUs of the hospitals we studied. In most of these cases the patients are incompetent, but physicians and families usually agree to limit care.

Summary

All patients admitted to two medical-surgical ICUs from July 1987 to June 1998, and from whom life support was withheld or withdrawn, were studied. Among 1719 patients admitted to the ICU, life support was forgone from 115 (7%). Support was withheld from 22 (19%), and withdrawn from 93 (81%). In all, 198 patients died in the ICU, and 89 (45%) died after support was withheld or withdrawn. The remaining 26 of the 115 patients were transferred from the ICU with the expectation that they would die. Only one of these patients was discharged from the hospital; the remainder died on the ward within 2 weeks of ICU discharge. Sixty-six patients had intracranial lesions (18 with brain death), 17 were postoperative, 30 with respiratory failure, and 14 had underlying cancer. DNR orders were written for 107 of the patients (93%). One hundred and five patients (98%) died or were discharged from the ICU within 48 hours of the DNR order. Reasons for forgoing life support included brain death, poor prognosis, futility, extreme suffering, and a request by the patient or family. Mechanical ventilation was the intervention most commonly withdrawn, and vasopressors the intervention most frequently withheld.

Citation count 296

Related references

1. In the matter of Karen Quinlan, 70 NJ 10, 355 A2d 647 (1976).
2. Grenvik A, Powner DJ, Snyder JV, Jastremski MS, Babcock RA, Loughhead MG. Cessation of therapy in terminal illness and brain death. *Crit Care Med* 1978; **6**: 284–291.
3. Koch KA, Rodeffer HD, Wears RL. Changing patterns of terminal care management in an intensive care unit. *Crit Care Med* 1994; **22**: 233–243.
4. Prendergast TJ, Luce JM. Increasing incidence of withholding and withdrawal of life support from the critically ill. *Am J Respir Crit Care Med* 1997; **155**: 15–20.

Key message

Although withholding and withdrawing life support is relatively infrequent in the total number of patients admitted to the ICU, it is common in those patients who die and precipitates death in approximately half of these patients. Most patients are incompetent, and family members are involved and agree with physician recommendations in most cases.

Why it's important

This is the first study evaluating the manner, reasons, and circumstances under which life support is withheld or withdrawn in the ICU.

Strengths

1. Comprehensive study of two medical-surgical ICUs evaluating all patients admitted over an entire year.
2. Evaluation of underlying disorders, incidence of the activity, competency of the patients, and agreement of families with the decision.

Weaknesses

1. A closed format questionnaire was used which did not allow for all possible responses.
2. Poor prognosis and futility are not objective, diagnostic reasons for withholding or withdrawing therapy.

Relevance

Forgoing life-sustaining treatment is one of the most difficult decisions made in the ICU. This paper had added relevance with the increasing incidence of forgoing support in the ICU over the last several years.

Title

Determinants in Canadian health care workers of the decision to withdraw life support from the critically ill

Author

Cook DJ, Guyatt GH, Jaeschke R, Reeve J, Spanier A, King D, Molloy W, Willan A, Streiner DL, for the Canadian Critical Care Trials Group

Reference

JAMA 1995; **273**: 703–708

Abstract

Objective: To examine the attitudes of health care workers regarding the withdrawal of life support.

Design: Cross-sectional survey.

Participants: Attending staff, house staff, and intensive care unit (ICU) nurses in 37 Canadian university-affiliated hospitals.

Main Outcome Measures: Health care workers' ratings of the importance of 17 factors considered in the decision to withdraw life support, and their ratings of five levels of care, ranging from comfort measures to intensive care, in two of 12 different clinical scenarios.

Results: We surveyed 1361 respondents (149 of 167 potentially eligible ICU attending staff, 142 of 173 ICU house staff, and 1070 of 1455 ICU nurses, with response rates of 89%, 82% and 74% respectively). The most important factors were likelihood of surviving the current episode, likelihood of long-term survival, premorbid cognitive function, and age of the patient. In choosing the level of care for the patient scenarios, the same option was chosen by more than 50% of respondents in only one of 12 scenarios; opposite extremes of care were chosen by more than 10% of the respondents in eight of 12 scenarios. Respondent characteristics affecting choices included the number of years since graduation, the city and province in which they worked, the number of beds in their ICU, and their assessment of the likelihood that they would withdraw life support in comparison with their colleagues ($p < 0.001$ for all comparisons).

Conclusions: While ICU health care workers consistently identify a number of patient factors as important in decisions to withdraw care, there is extreme variability, which may be explained in part by the values of individual health care providers.

Summary

A cross-sectional survey of attending staff, house staff, and ICU nurses in 37 Canadian university-affiliated hospitals was performed to examine the attitudes of health care workers regarding the withdrawal of life support in the critically ill. Factors that were varied in the 12 scenarios were age (45 vs 75 years), premorbid cognitive function (highly functional vs encephalitis or Alzheimer's disease), likelihood of surviving current episode (50% vs 90% mortality), and likelihood of long-term survival (50% 1-year mortality vs no underlying comorbidity affecting long-term survival). Scenarios were created in which the patient, family, or friends could not help with a decision, and health care workers' attitudes were assessed. A total of 1361 health care workers in 37 Canadian hospitals in 8 provinces responded. The 10 top determinants of withdrawal of life support were likelihood of surviving the current episode, patient advance directives, premorbid cognitive function, likelihood of long-term survival, family directives, premorbid physical function, age, risk of legal complications,

hospital policy, and compliance with medical care. The variability in responses to every scenario was striking. The respondent variables that were significantly associated with the level of care chosen in the scenarios were the number of years since graduation, the number of ICU beds, province, and city. The determinants of withdrawal that proved to be significant predictors of the level of care in the multiple regression analysis were likelihood of long-term survival, and premorbid physical function. All four primary factors that were varied in the scenarios (age, likelihood of surviving current illness, long-term survival, and premorbid cognitive function) proved significant in multivariate analyses.

Citation count 198

Related references

1. Poses RM, Bekes C, Copare FJ, Scott WE. The answer to 'What are my chances, doctor?' depends on whom is asked: prognostic disagreement and inaccuracy for critically ill patients. *Crit Care Med* 1989; **17**: 827–833.
2. Wachter RM, Luce JM, Hearst N, Low B. Decisions about resuscitation: inequities among patients with different but similar prognosis. *Ann Intern Med* 1989; **111**: 525–532.
3. Christakis NA, Asch DA. Biases in how physicians chose to withdraw life support. *Lancet* 1993; **342**: 642–646.
4. Prendergast TJ, Claessens MT, Luce JM. A national survey of end-of-life care for critically ill patients. *Am J Respir Crit Care Med* 1998; **158**: 1163–1167.

Key message

Although ICU health workers consistently identify specific variables as important in deciding to withdraw care, there is extreme variability in their decision-making which appears to be explained by the values and beliefs of the care provider, rather than the patient or surrogate decision-maker.

Why it's important

Although patient autonomy is stressed throughout North America, the present study emphasizes the fact that end-of-life care for a given patient is determined more by the individual health care worker's values than the patient's. It is the first study to document the diversity of approaches to decision-making among different professionals.

Strengths

1. The development of a reliable and validated instrument, using a rigorous methodology with a high response rate.
2. The multi-center national perspective, including ICU doctors and nurses.

Weaknesses

1. Questionnaire which assessed what health care workers stated they would do, rather than observing their actual practice.
2. Patient directives, family wishes, or the complex interplay between these and other factors were not addressed.

Relevance

Because of the marked variability in health care provider decision-making at the end of life, the same patient with the same disease and prognosis may receive full aggressive intensive care from one health professional, and only comfort measures from another.

Title

A controlled trial to improve care for seriously ill hospitalized patients: the study to understand prognoses and preferences for outcomes and risks of treatments (SUPPORT)

Author

The SUPPORT principal investigators – Connors AF, Dawson NV, Desbiens NA, Fulkerson WJ Jr, Goldman L, Knaus WA, Lynn J, Oye RK

Reference

JAMA 1995; **274**: 1591–1598

Abstract

Objectives: To improve end-of-life decision making and reduce the frequency of a mechanically supported, painful, and prolonged process of dying.

Design: A 2-year prospective observational study (phase I) with 4301 patients, followed by a 2-year controlled clinical trial (phase II) with 4804 patients and their physicians randomized by specialty group to the intervention group (n = 2652), or control group (n = 2152).

Setting: Five teaching hospitals in the United States.

Patients: A total of 9105 adults hospitalized with one or more of nine life-threatening diagnoses; an overall 6-month mortality rate of 47%.

Intervention: Physicians in the intervention group received estimates of the likelihood of 6-month survival for every day up to 6 months, outcomes of cardiopulmonary resuscitation (CPR), and functional disability at 2 months. A specially trained nurse had multiple contacts with the patient, family, physician, and hospital staff to elicit preferences, improve understanding of outcomes, encourage attention to pain control, and facilitate advance care planning and patient-physician communication.

Results: The phase I observation documented shortcomings in communication, frequency of aggressive treatment, and the characteristics of hospital death: only 47% of physicians knew when their patients preferred to avoid CPR; 46% do-not-resuscitate (DNR) orders were written within 2 days of death; 38% of patients who died spent at least 10 days in an ICU; and for 50% of conscious patients who died in the hospital, family members reported moderate to severe pain at least half the time. During the phase II intervention, patients experienced no improvement in patient-physician communication (e.g., 37% of control patients and 40% of intervention patients discussed CPR preferences), or in the five targeted outcomes, i.e., incidence or timing of written DNR orders (adjusted ratio, 1.02; 95% confidence interval [CI], 0.90 to 1.15), physicians' knowledge of the patients' preferences not to be resuscitated (adjusted ratio, 1.22; 95% CI, 0.99 to 1.49), number of days spent in an ICU, receiving mechanical ventilation, or comatose before death (adjusted ratio, 0.97; 95% CI, 0.87 to 1.07), or level of reported pain (adjusted ratio, 1.15; 95% CI, 1.00 to 1.33). The intervention also did not reduce use of hospital resources (adjusted ratio, 1.05; 95% CI, 0.99 to 1.12).

Conclusions: The phase I observation of SUPPORT confirmed substantial shortcomings in care for seriously ill hospitalized adults. The phase II intervention failed to improve care or patient outcomes. Enhancing opportunities for more patient-physician communication, although advocated as the major method for improving patient outcomes, may be inadequate to change established practices. To improve the experience of seriously ill and dying patients, greater individual and societal commitment, and more proactive and forceful measures may be needed.

Summary

The observational study took place from June 1989 to June 1991, and the controlled clinical trial from January 1992 to January 1994, in patients with a predicted 6-month mortality of approximately 50%. Serious problems were noted in hospitalized patients at the end of life, including considerable pain, poor communication between physicians and patients, and lack of implementing patients' wishes. In phase I, 49% patients who wanted CPR withheld did not have a DNR order written. Substantial variation in outcomes was found among physicians, and across the five institutions. Physicians received at least one prognostic report for 94% of patients, and at least one report of patient or surrogate understanding and preferences in 78% of cases. The intervention did not change the proportion of patients or surrogates reporting a discussion about CPR (37% control vs 40% intervention). Of patients who did not have such a discussion, 41% of each group said they would like to discuss CPR. In the second physician interview, 59% acknowledged receiving the prognostic reports, and 34% the preference reports. Only 15% of doctors reported discussing the specific information with patients or family. Most patients and families indicated that they were satisfied, no matter what happened. An intervention to improve end-of-life decision-making by providing physicians with prognostic information and patient preferences was ineffective.

Citation count 1080

Related references

1. Vincent JL. European attitudes toward ethical problems in intensive care medicine: results of an ethical questionnaire. *Intensive Care Med* 1990; **16**: 256–264.
2. Society of Critical Care Medicine Ethics Committee. Attitudes of critical care medicine professionals concerning forgoing life sustaining treatments. *Crit Care Med* 1992; **20**: 320–326.
3. Asch DA, Hansen-Flaschen J, Lanken PN. Decisions to limit or continue life-sustaining treatment by critical care physicians in the United States: conflicts between physicians' practices and patients' wishes. *Am J Respir Crit Care Med* 1995; **151**: 288–292.
4. Wilson WC, Smedira NG, Fink C, McDowell JA, Luce JM. Ordering and administration of sedatives and analgesics during the withholding and withdrawal of life support from critically ill patients. *JAMA* 1992; **267**: 949–953.

Why it's important

The SUPPORT study documents serious problems in end-of-life care in hospitalized patients. Providing physicians with more information concerning patients' prognoses and preferences will not change physician behavior in improving end-of-life care.

Strengths

1. Rigorous scientific method in an extremely complex project.
2. A large number of patients in five diverse hospital settings.
3. An important baseline period and good response rates.

Weaknesses

1. Despite significant time, efforts, and costs, the authors were unable to show an improvement in physician behaviour.
2. Inadequate communication, not implementing patients' previous wishes, and dying in an ICU are not necessarily indicative that what was best for the patient was not achieved.

Relevance

End-of-life decisions are made daily in hospitalized patients. Physicians must become more sensitive to their inadequacies in providing end-of-life care, and become more sensitive to patients' needs.

Title

Consensus report on the ethics of foregoing life-sustaining treatments in the critically ill

Author

Task Force on Ethics of the Society of Critical Care Medicine

Reference

Crit Care Med 1990; **18**: 1435–1439

Abstract

None

Summary

A consensus statement pertaining to critically ill patients and the issues involved in foregoing life-sustaining treatments was developed. Issues including the spectrum of forgoing treatment, decision-making capacity, and the lack of decision-making capacity were addressed. The patient or the patient's surrogate is the source of authorization for decisions to treat or not. Advance directives should be actively and prospectively solicited. Both preservation of life and quality of life must be weighed when making decisions concerning withholding and withdrawing life-sustaining treatments. A patient may judge that it is preferable to forgo therapy than to receive it, or clinicians may judge that major goals of therapy are unachievable. A decision to withdraw a treatment already initiated should not necessarily be ethically regarded as more problematic than a decision not to initiate a treatment. Any treatment derives its medical justification from the benefits that the informed patient and the physician hope to achieve by employing it.

Forgoing therapy should be discussed when the patient has a diagnosis with a grave prognosis, when the burdens of therapy outweigh the benefits, and when the quality of the patient's life is expected to be unacceptable to the patient. The health care professional has no obligation to offer, begin, or maintain a treatment which in his best judgement will be physiologically futile. As in all clinical decision-making, effective communication between the patient, the patient's family or surrogate, and the health care team is of paramount importance. Patients, families, and surrogates should be regularly included in discussions and decisions regarding therapy. While the patient still has the capacity to make decisions during the course of a grave illness, or when the patient is facing the prospect of a risky course of treatment, it is ethically appropriate and prudent to initiate discussions regarding potential limitations on therapy.

In a decision to withhold or withdraw therapy, there are no intrinsic moral differences between the categories of treatments such as CPR, ventilatory support, medications such as vasopressors, antibiotics, and insulin, and the provision of nutrition and hydration by artificial means. A minority dissent classified hydration and nutrition outside of medical interventions. Treatment decisions should be considered in the context of the goals of the total treatment plan for the patient, rather than in isolation. The continued efficacy and justification for any ongoing course of therapy should be re-evaluated at appropriate intervals in light of changing conditions. Unlike a decision to initiate life-sustaining procedures – which must often be made as an emergency to permit a full evaluation of the patient's condition, and a knowledgeable assessment of the likely benefits of available treatments – a decision to withdraw a life-sustaining treatment should be made only after deliberate

consideration of the ethical factors involved. Treatments that offer no benefit and serve to prolong the dying process should not be employed. The removal of life support from a patient should not be regarded as abandonment of the patient. Health care professionals have the obligation to continue supportive care and treatment for pain and suffering.

Decision-making capacity includes the following abilities: to appreciate the significant characteristics of one's condition; to appreciate the impact of the main treatment options; to judge the relationship of options to one's beliefs and values; to reason and to deliberate about one's choices, and to communicate decisions in a meaningful manner. The wishes of an informed adult patient who has the capacity to make decisions should be the primary and most weighty consideration in almost all decisions regarding treatment. When patients are deemed to lack decision-making capacity, and surrogates are involved, decision-making usually rests with the family or close associates. Mechanisms for dispute resolutions are also provided.

Citation count None

Related references

1. President's Commission for the Study of Ethical Problems in Medicine, Biomedical and Behavioral Research. *Deciding to Forgo Life-sustaining Treatment: A Report on Ethical, Medical and Legal Issues in Treatment Decisions*. Washington, DC: US Government Printing Office, 1983.
2. American Thoracic Society. Withholding and withdrawing life-sustaining therapy. *Am Rev Respir Dis* 1991; **144**: 726–731.
3. Bone RC, Rackow EC, Weg JG, and members of the ACCP/SCCM Consensus Panel. Ethical and moral guidelines for the initiation, continuation, and withdrawal of intensive care. *Chest* 1990; **97**: 949–958.

Key message

A consensus has developed that when treatments offer no benefit and serve to prolong the dying process, they may be withheld or withdrawn.

Why it's important

The present consensus report was the first to be developed for the forgoing of life-sustaining treatments in critically ill patients by a multi-disciplinary group of experts in medicine, especially in critical care medicine, law, ethics, philosophy, religion, and patient advocates.

Strengths

The development of consensus regarding the forgoing of life-sustaining treatments covering several controversial areas.

Weaknesses

Consensus could not be reached related to hydration and nutrition being medical interventions.

Relevance

Consensus reports related to medical, ethical, legal, and religious issues are extremely important for developing standards of practice and statements for legal opinions.

Title

A definition of irreversible coma

Author

Ad Hoc Committee of the Harvard Medical School to Examine the Definition of Brain Death – Beecher HK, Adams RD, Barger AC, Curran WJ, Denny-Brown D, Farnsworth DL, Folch PJ, Mendelsohn EI, Merrill JP, Murray J, Potter R, Schwab R, Sweet W

Reference

JAMA 1968; **205**: 337–340

Abstract

None

Summary

The characteristics of a permanently non-functioning brain were determined to define irreversible coma as a new criterion for death. The condition can be satisfactorily diagnosed by (1) unreceptivity and unresponsivity, (2) no movements or breathing, and (3) no reflexes. A fourth confirmatory test is a flat electroencephalogram. All of the above tests shall be repeated at least 24 hours later, with no change to provide evidence of the irreversibility of the condition. The validity of such data as indications of irreversible cerebral damage depends on the exclusion of two conditions: hypothermia (temperature < 90°F [32.2°C]), or evidence of drug intoxication, such as barbiturates. It is suggested that the physician in charge of the patient consult with one or more other physicians directly involved before the patient is declared brain dead on the basis of these criteria. It is further suggested that the decision to declare the patient dead, and then to turn off the respirator, be made by physicians not involved in any later effort to transplant organs or tissues from the deceased individual. Irreversible coma can have various causes, including cardiac arrest, asphyxia, massive brain damage, and intracranial lesions – neoplastic or vascular.

Two reasons for the need for a new definition of death (1) improvements in resuscitative and supportive measures can lead to patients whose heart continues to beat, but whose brain is irreversibly damaged, and (2) obsolete criteria for the definition of death can lead to controversy in obtaining organs for transplantation.

Citation count 105

Related references

1. President's Commission for the Study of Ethical Problems in Medicine, Biomedical and Behavioral Research. *Defining Death: A Report on the Medical, Legal and Ethical Issues in the Determination of Death*. Washington, DC: US Government Printing Office, 1981.
2. Youngner SJ, Landefeld CS, Coulton CJ *et al*. Brain death and organ retrieval: a cross-sectional survey of knowledge and concepts among health professionals. *JAMA* 1989; **261**: 2205–2210.

3. Halevy A, Brody B. Brain death: reconciling definitions, criteria, and tests. *Ann Intern Med* 1993; **119**: 519–525.
4. Truog RD. Is it time to abandon brain death? *Hastings Center Report* 1997; **27**: 29–37.

Key message

A patient with a permanently non-functioning brain and irreversible coma can be diagnosed clinically. Physicians should use irreversible coma as a new criterion for death.

Why it's important

This report is the precedent for the medical and legal consensus that has led to the acceptance of brain death.

Strengths

Authoritative statement made by leading experts from the Harvard Medical School and the Massachusetts General Hospital.

Weaknesses

The report provides no objective data confirming that the proposed clinical criteria for irreversible coma and a permanent non-functioning brain are synonymous with death.

Relevance

The use of brain death criteria as additional medical and legal criteria to define death is accepted worldwide, and has significantly increased organ transplantation.

Cytokines

Helen F. Galley and Nigel R. Webster

Introduction

Orchestration of host responses to infection or injury depends upon communication between cells by soluble molecules given the generic term cytokines. These are low molecular weight secreted proteins that regulate both the amplitude and duration of a huge range of responses. They have multiple effects on growth and differentiation in many cell types, with considerable redundancy of action. Interaction may occur in a network or cascade system in which one cytokine induces another, through modulation of the receptor of another cytokine, and through either synergism or antagonism of two cytokines acting on the same cell. Specific actions depend on the stimulus, the cell type, and the presence of other mediators and receptors.

Over the last 30 years, cytokine research has moved from identification of literally hundreds of mediators to the unraveling of the complex interactions and redundancy of action of these profoundly important proteins. Early studies grappled with today's understanding of redundancy, mutual induction, and autocrine effects. The explosion of research in the 1980s – spearheaded by Charles Dinarello, who is currently publishing studies on interleukin number 18 – was phenomenal, and highly relevant to the understanding of inflammatory mechanisms in critical care.

The advances made in the understanding of the molecular mechanisms of sepsis and organ dysfunction have not been followed by similar advances in the application of such knowledge to the management of patients. Despite the unsuccessful trials of immunotherapy (e.g. tumor necrosis factor antibody), some progress was made, and these failed approaches were learning experiences. Clear definitions of sepsis were agreed upon. The appreciation that animal models of sepsis are not reflective of the human disease process was also realized. In addition, it was also acknowledged that human responses were not always the same as in other species. Clinical trial design has also been improved, and there is now an acceptance of the need for large scale studies which recruit a homogeneous patient population, and which have clearly defined relevant outcome measures.

The first six papers we have chosen provide a chronological journey from the initial discovery of endogenous pyrogenic mediators (later identified as interleukin-1 and tumor necrosis factor), to the role of cytokines in the pathophysiology of sepsis and septic shock, and the use of therapeutic measures in an attempt to ameliorate the effects of activation of these pathways. Paper number 7 deviates a little and describes the role of a transcription factor, nuclear factor kappa B, in cytokine activation in sepsis. The next two papers describe the use of cytokines as therapeutic agents in other clinical conditions; interferon for hepatitis C, and interleukin-2 for melanoma and renal cell carcinoma. The latter study also reports on the role of nitric oxide in the hypotension and increased capillary permeability seen in patients undergoing cytokine treatment, with obvious relevance to sepsis. The final paper is not an original research study, but rather a viewpoint of eminent critical care specialists from Europe and the USA, suggesting that more narrowly defined criteria for sepsis, incorporating, for example, both biochemical and immunological measures, would result in better targeted therapy and, ultimately, greater therapeutic success.

Title

Demonstration and characterization of two distinct human leukocytic pyrogens

Author

Dinarello CA, Goldin NP, Wolff SM

Reference

J Exp Med 1974; **139**: 1369–1381

Abstract

Not available

Summary

This paper was one of the earliest papers describing the chemical and biological properties of what later transpired to be cytokines, from human leukocytes. Monocytes and neutrophils were separated from normal donor blood and incubated with heat-killed staphylococci. The cell supernatants were injected into rabbits to determine pyrogenic activity, and the monocyte preparation produced 20 times more pyrogenic activity than the neutrophil preparation. Two separate proteins were isolated from the monocyte and neutrophil preparations by gel filtration. The monocyte protein was 38,000 kDa and had an isoelectric point of 5.1; the neutrophil protein was around 15,000 kDa and had an isoelectric point of 6.9.

Citation count

149

Related references

1. Atkins E. Pathogenesis of fever. *Physiol Rev* 1960; **60**: 580.
2. Dinarello CA, Renfer L, Wolff SM. The production of antibody against human leukocytic pyrogen. *J Clin Invest* 1977; **60**: 465–472.
3. Dinarello CA, Bernheim HA, Duff GW *et al*. Mechanisms of fever induced by recombinant human interferon. *J Clin Invest* 1984; **74**: 906–913.

Key message

Fever is induced in animals in response to bacteria and bacterial products by endogenous substances released from leukocytes.

Strengths

The paper described detailed and methodical investigation of the pyrogens produced by human leukocytes on exposure to bacteria.

Weaknesses

The cell populations labelled monocytes were in fact mononuclear cells, comprising both monocytes and lymphocytes. It is now known, of course, that lymphocytes do produce cytokines, although the role of lymphocytes was completely discounted in this study. The possibility that the monocyte pyrogen was a dimer of the same protein produced by neutrophil, was also discounted.

Relevance

This paper demonstrated for the first time that two chemically distinct substances are produced, and contributed to the understanding of the pathogenesis of fever in man. Various investigators concluded that changes associated with infection were caused by this endogenous leukocyte pyrogen, now known as interleukin-1 (IL-1). The two pyrogens identified in this paper were subsequently identified as IL-1 α and IL-1 β , and it was later confirmed that fever and other host responses to infection and injury were indeed mediated by IL-1. However, IL-1 is not the only leukocyte product that induces fever, and investigators went on to consider the interactions of several endogenous pyrogens as mediators of fever, and to develop antibodies to enable easy detection and measurement of these substances.

Title

The functional relationship of the interleukins

Author

Smith KA, Lachman LB, Oppenheim JJ, Favata MF

Reference

J Exp Med 1980; **151**: 1551–1556

Abstract

The mechanism of the lymphoproliferative effect of the macrophage product lymphocyte-activating factor [LAF(IL1)] appears to be mediated by the stimulation of the release of T cell growth factor [TCGF(IL2)] by T cells. The magnitude of the resultant T cell proliferative clonal expansion is thus dependent upon the quantity of both LAF(IL1) and TCGF(IL2) induced by antigen or lectin stimulation. These observations, coupled with the ability to measure the production and actions of these hormone-like lymphokines, should allow for increased insight into the mode of action of immunoenhancing and immunosuppressive agents, as well as for new therapeutic approaches to disease states involving T lymphocytes.

Summary

This study describes a mechanism by which activated macrophages participate in the stimulation of proliferation of T cells. It was already known that T cell proliferation was mediated by a soluble substance called T cell growth factor (TCGF), now known to be interleukin-2 (IL-2), but that macrophages were required. This study revealed that the factor released from macrophages, termed lymphocyte-activating factor (originally referred to as leukocyte pyrogen), but now known to be interleukin-1 (IL-1), was able to stimulate the release of IL-2 from T cells. T cell-enriched splenocyte populations and peritoneal macrophages were isolated from mice. IL-1 was prepared from murine macrophages or human mononuclear leukocytes cultured with lipopolysaccharide (LPS, endotoxin), followed by concentration by ultrafiltration and isoelectric focusing. Proliferation of splenocytes in response to the mitogen, concanavalin A, and the requirement for IL-1 and IL-2 were assessed by tritiated thymidine incorporation.

Citation count 765

Related references

1. Gillis S, Crabtree GR, Smith KA. Glucocorticoid-induced inhibition of T cell growth factor production. II. The effect on the in vitro generation of cytolytic T cells. *J Immunol* 1979; **123**: 1632–1638.
2. Bloomfield CD, Smith KA, Peterson BA *et al.* In-vitro glucocorticoid studies for predicting response to glucocorticoid therapy in adults with malignant lymphoma. *Lancet* 1980; **1**: 952–956.

Key message

Cells interact to release cytokines, which have paracrine as well as autocrine effects. Studies of basic cellular mechanisms may also have diagnostic or therapeutic applications.

Strengths

The study used some rigorous control experiments to confirm the proposed mechanisms: the presence of adherent monocytes in T cell cultures replaced the need for IL-1; the use of dexamethasone, which blocks IL-2 release from T cells, inhibited the effect of IL-1; and IL-1 had no effect on splenocytes from nude (athymic) mice, since they do not produce IL-2.

Weaknesses

The preparation techniques used for purification of IL-1 and IL-2 were not sophisticated – today, recombinant proteins would be used – thus contamination of IL-1 with IL-2 and vice versa is possible. The authors made the assumption that LPS did not induce the release of IL-2. However, we now know that many other cytokines are induced by LPS, which interact in a network.

Relevance

This paper began the complex unraveling of the interactive nature of the host response, and also increased the understanding of the action of immunosuppressive agents, i.e. glucocorticoids, on T cells. The same authors went on to describe an in vitro assay based on these studies, to determine tumor glucocorticoid sensitivity, which allowed selection of those patients with lymphoma who should receive glucocorticoids as part of combination chemotherapy.

Title***Tumor necrosis factor (cachectin) is an endogenous pyrogen and induces production of interleukin 1***

Author

Dinareello CA, Cannon JG, Wolff SM, Bernheim HA, Beutler B, Cerami A, Figari IS, Palladino MA, O'Connor JV

Reference

J Exp Med 1986; **163**: 1433–1450

Abstract

Recombinant human tumor necrosis factor (rTNF- α) injected intravenously into rabbits produces a rapid-onset, monophasic fever indistinguishable from the fever produced by rIL-1. On a weight basis (1 μ g/kg), rTNF- α and rIL-1 produce the same amount of fever and induce comparable levels of PGE₂ in rabbit hypothalamic cells in vitro; like IL-1, TNF fever is blocked by drugs that inhibit cyclooxygenase. At higher doses (10 μ g/kg) rTNF- α produces biphasic fevers. The first fever reaches peak elevation 45–55 minutes after bolus injection, and likely represents a direct action on the thermoregulatory center. During the second fever peak (3 hours later), a circulating endogenous pyrogen can be shown to be present using passive transfer of plasma into fresh rabbits. This likely represents the in vivo induction of IL-1. In vitro, rTNF- α induces the release of IL-1 activity from human mononuclear cells, with maximal production observed at 50–100 ng/ml of rTNF- α . In addition, rTNF- α and rIFN- γ have a synergistic effect on IL-1 production. The biological activity of rTNF- α could be distinguished from IL-1 in three ways: the monophasic pyrogenic activity of rIL-1 was destroyed at 70°C, whereas rTNF- α remained active; anti-IL-1 neutralized IL-1 but did not recognize rTNF- α or natural cachectin, nor neutralize its cytotoxic effect; and, unlike IL-1, rTNF- α was not active in the mitogen-stimulated T cell proliferation assay. The possibility that endotoxin was responsible for rTNF- α fever and/or the induction of IL-1 was ruled-out in several studies: rTNF- α produced fever in the endotoxin-resistant C3H/HeJ mice; the IL-1-inducing property of rTNF- α was destroyed either by heat (70°C) or trypsinization, and was unaffected by polymyxin B; pyrogenic tolerance to daily injections of rTNF- α did not occur; levels of endotoxin, as determined in the Limulus amoebocyte lysate, were below the minimum rabbit pyrogen dose; and these levels of endotoxin were confirmed by gas chromatography/mass spectrometry analysis for the presence of beta-hydroxymyristic acid. Although rTNF- α is not active in T cell proliferation assays, it may mimic IL-1 in a T cell assay, since high concentrations of rTNF- α induced IL-1 from epithelial or macrophagic cells in the thymocyte preparations. These studies show that TNF (cachectin) is another endogenous pyrogen which, like IL-1 and IFN- α , directly stimulate hypothalamic PGE₂ synthesis. In addition, rTNF- α is an endogenous inducer of IL-1

Summary

It had already been shown that bacterial pyrogens initiated fever by increasing prostaglandin E₂ (PGE₂) synthesis in the area of the hypothalamus, thus explaining the effect of antipyretic agents, which were also cyclooxygenase inhibitors. Recombinant IL-1, and later interferon, were known to produce a similar effect when injected into experimental animals. This paper was the first report of another leukocyte-derived compound called tumor necrosis factor, or cachectin, which was also intrinsically pyrogenic. Recombinant

human tumor necrosis factor (rTNF- α), when injected intravenously into rabbits, produced a rapid onset, monophasic fever indistinguishable from the fever produced by rIL-1. On a weight basis (1 $\mu\text{g}/\text{kg}$), rTNF- α and rIL-1 produced the same amount of fever in rabbits, and in rabbit hypothalamic cells in vitro, TNF induced similar levels of PGE₂ release. Like IL-1, the fever induced by TNF was blocked by cyclooxygenase inhibitors. At higher doses (10 $\mu\text{g}/\text{kg}$), rTNF- α produced a biphasic fever – the first fever reaching a peak at 45–55 minutes after bolus injection – thought to represent a direct action on the thermoregulatory center. During the second fever peak (3 hours later), release of a circulating endogenous pyrogen was shown on passive transfer of plasma into different rabbits. This was assumed to be due to the in vivo induction of IL-1. In vitro, rTNF- α induced the release of IL-1 activity from human mononuclear cells, and rTNF- α and rIFN- α had a synergistic effect on IL-1 production.

Citation count 1449

Related references

1. Morimoto A, Sakata Y, Watanabe T, Murakami N. Characteristics of fever and acute phase response induced in rabbits by IL-1 and TNF. *Am J Physiol* 1989; **256**: R35–R41.
2. Delpech M, Grateau G. Genetically determined recurrent fevers. *Curr Opin Immunol* 2001; **13**: 539–542.
3. van Dissel JT, van Langevelde P, Westendorp RG, Kwappenberg K, Frolich M. Anti-inflammatory cytokine profile and mortality in febrile patients. *Lancet* 1998; **351**: 950–953.

Key message

The studies showed that TNF (cachectin) was another endogenous pyrogen which, like IL-1 and interferon (IFN)- γ , directly stimulated hypothalamic PGE₂ synthesis. However, perhaps more importantly, rTNF- α was shown to induce endogenous IL-1 release.

Strengths

The paper used a variety of techniques, in vivo and in vitro studies, as well as early molecular biology techniques. The authors recognized that there may have been contaminating endotoxin in the recombinant preparations, and therefore undertook control studies in endotoxin-resistant mice.

Weaknesses

It is now known that TNF will also cause the release of inhibitory cytokines, which could alter IL-1 release. It was also assumed that IL-1 was the cytokine responsible for the effects, since at the time this was the only other known pyrogen apart from interferon. The authors also dismissed the concept that cytokines are able to induce their own production – an effect that is now known to occur.

Relevance

This paper explained the dilemma of a multitude of effects that were originally assumed to be due to a single pyrogen. Research continues to be undertaken on the role of TNF in fevers at both the genetic and molecular levels. It has recently been shown that high levels of anti-inflammatory cytokines relative to TNF levels is associated with fatal outcome in febrile patients.

Title

Anti-cachectin/TNF monoclonal antibodies prevent septic shock during lethal bacteraemia

Author

Tracey KJ, Fong Y, Hesse DG, Manogue KR, Lee AT, Kuo GC, Lowry SF, Cerami A

Reference

Nature 1987; **330**: 662–664

Abstract

Bacterial infection of the mammalian bloodstream can lead to overwhelming sepsis, a potentially fatal syndrome of irreversible cardiovascular collapse (shock) and critical organ failure. Cachectin, also known as tumor necrosis factor, is a macrophage-derived peptide hormone released in response to bacterial lipopolysaccharide, and it has been implicated as a principal mediator of endotoxic shock, although its function in bacterial sepsis is not known. Anesthetized baboons were passively immunized against endogenous cachectin, and subsequently infused with an LD100 dose of live *Escherichia coli*. Control animals (not immunized against cachectin) developed hypotension followed by lethal renal and pulmonary failure. Neutralizing monoclonal anti-cachectin antibody fragments (F(ab')₂), administered to baboons only one hour before bacterial challenge, protected against shock, but did not prevent critical organ failure. Complete protection against shock, vital organ dysfunction, persistent stress hormone release, and death was conferred by administration of antibodies 2 hours before bacterial infusion. These results indicate that cachectin is a mediator of fatal bacteremic shock, and suggest that antibodies against cachectin offer a potential therapy for life-threatening infection.

Summary

It was known that bacterial infection could lead to overwhelming sepsis, a potentially fatal syndrome of irreversible cardiovascular collapse (shock), and ensuing organ dysfunction and failure. It was known that tumor necrosis factor was released from macrophages in response to bacterial lipopolysaccharide. Although it had been implicated as a principal mediator of endotoxic shock, the function of TNF in bacterial sepsis was not known. In this paper, anesthetised baboons were passively immunized against endogenous TNF, and subsequently infused with an LD100 dose of live *Escherichia coli*. Control animals (not immunized against TNF) developed hypotension followed by lethal renal and pulmonary failure. Neutralizing monoclonal anti-TNF antibody fragments (F(ab')₂), administered to the baboons only 1 hour before bacterial challenge, protected against shock, but did not prevent critical organ failure. Complete protection against shock, vital organ dysfunction, persistent stress hormone release, and death was conferred by administration of antibodies 2 hours before bacterial infusion.

Citation count **1990**

Related references

1. Tracey KJ, Beutler B, Lowry SF *et al.* Shock and tissue injury induced by recombinant human cachectin. *Science* 1986; **234**: 470–474.
2. Waage A, Halstensen A, Espevik T. Association between tumour necrosis factor in serum and fatal outcome in patients with meningococcal disease. *Lancet* 1987; **1**: 355–357.

Key message

TNF is a mediator of fatal bacteremic shock.

Strengths

This was an extremely simple study undertaken in animals as closely related to humans as possible.

Weaknesses

The model of septic shock differs from that seen in humans in that it was much more rapidly fatal. Animals were not treated in the same way that patients would have been treated. The application of TNF antibody therapy to humans was always likely to be unsuccessful, as pre-treatment would not be possible. At the time, the essential nature of TNF in stimulating the production of protective anti-inflammatory cytokines was not appreciated.

Relevance

This study showed that TNF was a mediator of sepsis and septic shock, and suggested that TNF antibody treatment may be useful in patients.

Title

Treatment of gram-negative bacteremia and septic shock with HA-1A human monoclonal antibody against endotoxin: a randomized, double-blind, placebo-controlled trial

Author

Ziegler EJ, Fisher CJ, Sprung CL, Straube RC, Sadoff JC, Foulke GE, Wortel CH, Fink MP, Dellinger RP, Teng NNH, Allen IE, Berger HJ, Knatterud GL, LoBuglio AF, Smith CR and the HA-1A Sepsis Study Group

Reference

N Engl J Med 1991; **324**: 429–436

Abstract

BACKGROUND. HA-1A is a human monoclonal IgM antibody that binds specifically to the lipid A domain of endotoxin, and prevents death in laboratory animals with gram-negative bacteremia and endotoxemia. **METHODS.** To evaluate the efficacy and safety of HA-1A, we conducted a randomized, double-blind trial in patients with sepsis and a presumed diagnosis of gram-negative infection. The patients received either a single 100-mg intravenous dose of HA-1A (in 3.5 g of albumin), or placebo (3.5 g of albumin). Other interventions, including the administration of antibiotics and fluids, were not affected by the study protocol. **RESULTS.** Of 543 patients with sepsis who were treated, 200 (37%) had gram-negative bacteremia as proved by blood culture. For the patients with gram-negative bacteremia followed to death or day 28, there were 45 deaths among the 92 recipients of placebo (49%), and 32 deaths among the 105 recipients of HA-1A (30%; $p = 0.014$). For the patients with gram-negative bacteremia and shock at entry, there were 27 deaths among the 47 recipients of placebo (57%) and 18 deaths among the 54 recipients of HA-1A (33%; $p = 0.017$). Analyses that stratified according to the severity of illness at entry showed improved survival with HA-1A treatment in both severely ill and less severely ill patients. Of the 196 patients with gram-negative bacteremia who were followed to hospital discharge or death, 45 of the 93 given placebo (48%) were discharged alive, as compared with 65 of the 103 treated with HA-1A (63%; $p = 0.038$). No benefit of treatment with HA-1A was demonstrated in the 343 patients with sepsis who did not prove to have gram-negative bacteremia. For all 543 patients with sepsis who were treated, the mortality rate was 43% among the recipients of placebo, and 39% among those given HA-1A ($p = 0.24$). All patients tolerated HA-1A well, and no anti-HA-1A antibodies were detected. **CONCLUSIONS.** HA-1A is safe and effective for the treatment of patients with sepsis and gram-negative bacteremia.

Summary

HA-1A is a human monoclonal IgM antibody that binds specifically to the lipid A domain of endotoxin, and had been shown to prevent death in laboratory animals with either gram-negative bacteremia or after endotoxin administration. This paper reported a randomized, double-blind trial of HA-1A in patients with sepsis. Of 543 patients with sepsis who were treated, 200 (37%) were subsequently shown to have had gram-negative bacteremia, as proven by blood culture. The primary outcome measure was 28-day mortality; 45 of 92 (49%) placebo-treated patients with gram-negative bacteremia, and 32 of the 105 (30%) recipients of HA-1A died ($p = 0.014$). In the patients with gram-negative bacteremia and

shock at entry, there were 27 deaths among the 47 recipients of placebo (57%), and 18 deaths among the 54 recipients of HA-1A (33%; $p = 0.017$). Analyses which were stratified according to the severity of illness at entry showed improved survival with HA-1A treatment in both severely ill and less severely ill patients. Of the 196 patients with gram-negative bacteremia who were followed to hospital discharge or death, 45 of the 93 given placebo (48%) were discharged alive, as compared with 65 of the 103 with HA-1A (63%; $p = 0.038$). No benefit of treatment with HA-1A was demonstrated in the 343 patients with sepsis who did not prove to have gram-negative bacteremia. For all 543 patients with sepsis who were treated, the mortality rate was 43% in patients who received placebo and 39% in those given HA-1A ($p = 0.24$).

Citation count 1077

Related references

1. McCloskey RV, Straube RC, Sanders C, Smith SM, Smith CR. Treatment of septic shock with human monoclonal antibody HA-1A. A randomized, double-blind, placebo-controlled trial. CHESSTrial Study Group. *Ann Intern Med* 1994; **121**: 1–5.
2. Derkx B, Wittes J, McCloskey R. Randomized, placebo-controlled trial of HA-1A, a human monoclonal antibody to endotoxin, in children with meningococcal septic shock. European Pediatric Meningococcal Septic Shock Trial Study Group. *Clin Infect Dis* 1999; **28**: 770–777.

Key message

Retrospective analysis of subgroups should not be relied upon to yield conclusive evidence.

Strengths

The data were manipulated to give the interpretation desired by the authors. (Note that the summary given above is written in a similarly biased manner to the original paper.)

Weaknesses

It is clear on careful reading of the paper that the overall survival benefit of HA-1A was not significantly different to that seen in the placebo-treated patients.

Relevance

The study showed the possibilities for immunotherapy in patients with sepsis, but also showed the pitfalls of both undertaking and interpreting the results of such studies. Subsequent studies have also shown the lack of efficacy of this antibody.

Title

Efficacy and safety of monoclonal antibody to human tumor necrosis factor- α in patients with sepsis syndrome: a randomized, controlled, double-blind, multicenter clinical trial

Author

Abraham E, Wunderink R, Silverman H, Perl TM, Nasraway S, Levy H, Bone R, Wenzel RP, Balk R, Alred R, Pennington JE, Wherry JC for the TNF- α MAb Sepsis Study Group

Reference

JAMA 1995; **273**: 934–941

Abstract

OBJECTIVE–To evaluate the efficacy and safety of anti-tumor necrosis factor alpha monoclonal antibody (TNF- α MAb) in the treatment of patients with sepsis syndrome. **DESIGN**–Randomized, prospective, multicenter, double-blind, placebo-controlled clinical trial. **SETTING**–A total of 31 hospitals in the United States and Canada. **PATIENTS**–There were 994 patients with sepsis syndrome enrolled in this clinical trial, and 971 patients were infused with the study drug. **INTERVENTION**–Patients were prospectively stratified into shock or nonshock groups, and then randomized to receive a single infusion of 15 mg/kg of TNF- α MAb, 7.5 mg/kg of TNF- α MAb, or placebo. Patients received standard aggressive medical and surgical care during the 28-day postinfusion period. **OUTCOME MEASURE**–Twenty-eight-day all-cause mortality. **RESULTS**–The distribution of variables describing demographics, organ system dysfunction or failure, preinfusion Acute Physiology and Chronic Health Evaluation II score, number of organs failing at baseline, initial sites of infection, infecting microorganisms, antimicrobials used, and initial invasive procedures was similar among patients in the TNF- α MAb and placebo treatment arms. Among all infused patients, there was no difference in all-cause mortality in patients who received placebo as compared with those who received TNF- α MAb. In septic patients with shock ($n = 478$), there was a trend toward a reduction in all-cause mortality, which was most evident 3 days after infusion: 25 of 162 patients treated with 15 mg/kg of TNF- α MAb died, 22 of 156 patients treated with 7.5 mg/kg of TNF- α MAb died, and 44 of 160 patients in the placebo group died (15 mg/kg: 44% reduction vs placebo, $p = 0.01$; 7.5 mg/kg: 48.7% reduction vs placebo, $p = 0.004$). At day 28, the reduction in mortality for shock patients was not significant for either dose of TNF- α MAb relative to placebo (15 mg/kg, 61 deaths among 162 patients [37.7% mortality]; 7.5 mg/kg, 59 deaths among 156 patients [37.8% mortality]; placebo, 73 deaths among 160 patients [45.6% mortality]; $p = 0.20$ for 7.5 mg/kg, and $p = 0.15$ for 15 mg/kg). Serious adverse events were reported in 4.6% of all infused patients. No immediate hypersensitivity allergic reactions due to TNF- α MAb were reported. Serum sickness-like reactions were seen in 2.5% of patients receiving TNF- α MAb. **CONCLUSIONS**–There was no decrease in mortality between placebo and TNF- α MAb in all infused patients. In septic shock patients who received TNF- α MAb, a significant reduction in mortality was present 3 days after infusion. Although a trend toward reduced mortality continued at 28 days following treatment with TNF- α MAb, the difference in mortality among shock patients treated with placebo or TNF- α MAb was not significant.

Summary

This study evaluated the efficacy and safety of a murine anti-tumor necrosis factor-alpha monoclonal antibody (TNF- α MAb) in patients with sepsis syndrome. It was a randomized, prospective, multicenter, double-blind, placebo-controlled clinical trial, undertaken in 31 hospitals in the United States and Canada. There were 994 patients with sepsis syndrome, of whom 971 were infused with the study drug. Patients were prospectively stratified into shock or non-shock groups, and then randomized to receive either 15 mg/kg of TNF- α MAb, 7.5 mg/kg of TNF- α MAb, or placebo, by infusion over 30 minutes. Patients received standard aggressive medical and surgical care during the 28-day post-infusion period. Twenty-eight-day all-cause mortality was the primary end-point. There was no difference in mortality in patients who received placebo compared with those who received TNF- α MAb (15 mg/kg, 61 deaths among 162 patients (37.7% mortality); 7.5 mg/kg, 59 deaths among 156 patients (37.8% mortality); placebo, 73 deaths among 160 patients (45.6% mortality); $p = 0.20$ for 7.5 mg/kg, and $p = 0.15$ for 15 mg/kg). In those patients with shock ($n = 478$), there was a trend toward a reduction in mortality, which was most evident 3 days after infusion: 25 of 162 patients treated with 15 mg/kg of TNF- α MAb died, 22 of 156 patients treated with 7.5 mg/kg of TNF- α MAb died, and 44 of 160 patients in the placebo group died (15 mg/kg: 44% reduction versus placebo, $p = 0.01$; 7.5 mg/kg: 48.7% reduction versus placebo, $p = 0.004$). In patients with shock who received TNF- α MAb, a significant reduction in mortality was seen 3 days after infusion. Although the trend toward reduced mortality continued at 28 days following treatment with anti-TNF, the difference was not significant.

Citation count 427

Related references

1. Cohen J, Carlet J. INTERSEPT: an international, multicenter, placebo-controlled trial of monoclonal antibody to human tumor necrosis factor-alpha in patients with sepsis. International Sepsis Trial Study Group. *Crit Care Med* 1996; **24**: 1431–1440.
2. Abraham E, Anzueto A, Gutierrez *et al*. Double-blind randomised controlled trial of monoclonal antibody to human tumour necrosis factor in treatment of septic shock. NORASEPT II Study Group. *Lancet* 1998; **351**: 929–933.
3. Panacek E, Marshall J, Fischkoff S, Barhuk W, Teoh L, MONARCS study group. Neutralization of TNF by a monoclonal antibody improves survival and reduces organ dysfunction in human sepsis: results of the MONARCS trial. *Chest* 2000; **118**: 88S.

Key message

In patients with severe sepsis who were treated with a monoclonal anti-TNF antibody, there was a trend towards improved survival, most apparent in those patients with shock.

Strengths

The paper demonstrated that large-scale, well-conducted studies were possible in the critically ill.

Weaknesses

Trial entry criteria were changed part way through the study when it was observed at an interim analysis that there was no survival benefit in those patients without shock at study entry. It would be argued now that the study enrolled a heterogeneous group of patients.

In fact, it is now appreciated from this and other similar studies that many of the patients who died did so with either 'do not resuscitate orders' or following treatment withdrawal. There was no account made of the possible beneficial effects of TNF in terms of inducing a later endogenous anti-inflammatory response. Not all patients enrolled into the study would have had elevated TNF at the time of infusion of TNF MAb. There was a relatively long window of opportunity to enrol patients into the study – although this would have rendered the design more clinically applicable, it may have resulted in a falsely negative outcome to the study.

Relevance

If only those patients who were within 8 hours (or less) of developing sepsis, or who were known to have high levels of TNF, had perhaps been enrolled, then it is possible that this therapy would have entered routine clinical use. There have been many papers subsequently which have suggested more appropriate study designs for similar therapeutic agents.

Title***Role of NFκB in the mortality of sepsis***

Author

Bohrer H, Qiu F, Zimmermann T, Zhang Y, Jllmer T, Männel D, Bottiger BW, Stern DM, Waldherr R, Saeger H-D, Ziegler R, Bierhaus A, Martin E, Nawroth PP

Reference

J Clin Invest 1997; **100**: 972–985

Abstract

Binding activity for nuclear factor kappa B (NFκB) consensus probes was studied in nuclear extracts from peripheral blood mononuclear cells of 15 septic patients (10 surviving, and 5 not surviving). Nonsurvivors could be distinguished from survivors by an increase in NFκB binding activity during the observation period ($p < 0.001$). The increase in NFκB binding activity was comparable to the APACHE-II score as a predictor of outcome. Intravenous somatic gene transfer with an expression plasmid coding for IκBα was used to investigate the role of members of the NFκB family in a mouse model of endotoxemia. In this model, increased NFκB binding activity was present after injection of LPS. Intravenous somatic gene transfer with IκBα given before LPS attenuated renal NFκB binding activity, and increased survival. Endothelial cells and monocytes/macrophages were the major target cells for somatic gene transfer, transfected with an average transfection efficiency of 20-35%. Tissue factor, a gene under regulatory control of NFκB, was induced by LPS. Somatic gene transfer with a reporter plasmid containing the functional tissue factor promoter demonstrated NFκB-dependent stimulation by LPS. Intravenous somatic gene transfer with IκBα reduced LPS-induced renal tissue factor expression, activation of the plasmatic coagulation system (decrease of thrombin-antithrombin III complexes), and renal fibrin/fibrinogen deposition. Somatic gene transfer with an expression plasmid with tissue factor cDNA in the antisense direction (in contrast to sense or vector alone) also increased survival. Furthermore, antisense tissue factor decreased renal tissue factor expression and the activation of the plasmatic coagulation system.

Summary

Endotoxin is known to induce the expression of protein mediators through gene effects at the transcriptional level. The transcription factor nuclear factor kappa B (NFκB) regulates the production of many immune and inflammatory mediators, including cytokines. NFκB is maintained in a non-activated state in the cell cytoplasm and, on activation, is dissociated from an inhibitory subunit to reveal a nuclear recognition site. The activated NFκB then moves into the nucleus and binds to DNA on the target gene. This paper investigated NFκB activity in nuclear extracts from peripheral blood mononuclear cells of 15 patients with sepsis (5 of whom died). It was shown that non-survivors had increases in NFκB-binding activity during the observation period, such that the increase in NFκB-binding activity was comparable to the APACHE II score as a predictor of outcome. Intravenous somatic gene transfer with an expression plasmid coding for IκBα (the inhibitory subunit of NFκB) also attenuated tissue NFκB activity and increased survival in a mouse model of sepsis.

Citation count **272**

Related references

1. Blackwell TS, Christman JW. The role of nuclear factor kappa B in cytokine gene regulation. *Am J Respir Cell Mol Biol* 1997; **17**: 3–9.
2. Arnalich F, Garcia-Palomero E, Lopez J *et al.* Predictive value of nuclear factor kappa B activity and plasma cytokine levels in patients with sepsis. *Infect Immun* 2000; **68**: 1942–1945.
3. Paterson RL, Galley HF, Dhillon JK, Webster NR. Increased nuclear factor kappa B activation in critically ill patients who die. *Crit Care Med* 2000; **28**: 1047–1051.

Key message

NF κ B activation increases in leukocytes from patients with sepsis who subsequently die. Preventing NF κ B activation by increased inhibitor expression improved survival in endotoxemic mice.

Strengths

This study examined human material from patients with sepsis, and applied molecular biological techniques to this evaluation.

Weaknesses

Data manipulation was curious, and patient numbers were low. However, studies by other workers have gone on to show similar findings.

Relevance

NF κ B regulates a vast range of cytokines, adhesion molecules, and enzymes, and has a central role in immune and inflammatory responses. Some of the anti-inflammatory actions of cytokines like interleukin-10 and IL-13 are mediated through effects on the inhibitory sub-unit, I κ B. The activation of NF κ B involves, in part, an oxidative process, and antioxidants have been shown to attenuate cytokine expression in animal models and in vitro. Thus, antioxidant therapy in patients with sepsis may be a simple strategy to reduce NF κ B activation and abrogate cytokine responses via endogenous control mechanisms.

Title

Treatment of chronic hepatitis C with recombinant alpha-interferon: a multicenter, randomized, controlled trial: Hepatitis Interventional Therapy Group

Author

Davis GL, Balart LA, Schiff ER, Lindsay K, Bodenheimer HC Jr, Perrillo RP, Carey W, Jacobson IM, Payne J, Dienstag JL *et al.*

Reference

N Engl J Med 1989; **321**: 1501–1506

Abstract

To assess the efficacy of therapy with the antiviral agent interferon in chronic hepatitis C (non-A, non-B hepatitis), we randomly assigned 166 chronic hepatitis C patients to treatment with either 3 million or 1 million units of recombinant interferon α 2b three times weekly for 24 weeks, or to no treatment. The probability of normalization or near normalization of the serum alanine aminotransferase levels after 6 months of interferon therapy was 46% in patients treated with 3 million units of interferon ($p < 0.001$), and 28% in those treated with 1 million units ($p < 0.02$), but only 8% in untreated patients. Serum alanine aminotransferase levels became completely normal in 22 of the 26 patients (85%) who responded to treatment with 3 million units of interferon, and 9 of the 16 patients (56%) who responded to treatment with 1 million units. The patients who received 3 million units of interferon had histological improvement because of the regression of lobular and periportal inflammation. Relapse within 6 months after the completion of treatment occurred in 51% of the patients treated with 3 million units of interferon, and 44% of those treated with 1 million units. We conclude that a 24-week course of interferon therapy is effective in controlling disease activity in many patients with hepatitis C, although relapse after the cessation of treatment is common.

Summary

Chronic hepatitis C (non-A, non-B hepatitis) is a common, and often progressive, viral liver disease. This paper examined the efficacy of therapy with interferon- α in 166 patients with chronic hepatitis C, who were randomly assigned to treatment with either 3 million or 1 million units of recombinant interferon- α three times weekly, or to placebo, for 24 weeks. The probability of return of the serum alanine aminotransferase concentration to normal or near normal levels after 6 months of therapy was 46% in patients treated with 3 million units of interferon ($p < 0.001$), and 28% in those treated with 1 million units ($p < 0.02$), but only 8% (NS) in untreated patients. The patients who received 3 million units of interferon had histological improvement with the regression of lobular and periportal inflammation. Relapse within 6 months after the completion of treatment occurred in 51% of the patients treated with 3 million units of interferon, and 44% of those treated with 1 million units.

Citation count

1467

Related references

1. Davis GL. Recombinant alpha-interferon treatment of non-A, and non-B (type C) hepatitis: review of studies and recommendations for treatment. *J Hepatol* 1990; **11** (Suppl 1): S72–S77.
2. Perrillo RP, Schiff ER, Davis GL *et al*. A randomized, controlled trial of interferon alfa-2b alone and after prednisone withdrawal for the treatment of chronic hepatitis B. The Hepatitis Interventional Therapy Group. *N Engl J Med* 1990; **323**: 295–301.
3. Lindsay KL, Davis GL, Schiff ER *et al*. Response to higher doses of interferon alfa-2b in patients with chronic hepatitis C: a randomized multicenter trial. Hepatitis Interventional Therapy Group. *Hepatology* 1996; **24**: 1034–1040.

Key message

A 24-week course of interferon- α therapy was shown to be effective in controlling disease activity in patients with hepatitis C, although relapse after the cessation of treatment was common.

Strengths

This was a relatively large study, supported by objective histological and biochemical evidence of hepatic recovery.

Weaknesses

The data suggest that the dose of interferon may have been inadequate: indeed, subsequent studies have used higher doses, and have also administered interferon in combination with steroids or antiviral agents, with lower regression rates.

Relevance

This was one of a series of papers which were the first to describe the successful use of exogenous cytokines as immunotherapeutic agents. Interferon has been used subsequently in patients with sepsis in ICU to modify the immune response.

Title

Increased circulating nitrogen oxides after human tumor immunotherapy: correlation with toxic hemodynamic changes

Author

Ochoa JB, Curti B, Peitzman AB, Simmons RL, Billiar TR, Hoffman R, Rault R, Longo DL, Urba WJ, Ochoa AC

Reference

J Natl Cancer Inst 1992; **84**: 864–867

Abstract

BACKGROUND: Toxicity to interleukin-2 (IL-2) tumor immunotherapy is manifested principally by the vascular leak syndrome, hypotension, and a hyperdynamic response with low systemic vascular resistance. Nitric oxide (NO), a recently discovered biological mediator of vascular smooth muscle relaxation, is produced in increased amounts by numerous cell types exposed to a number of inflammatory cytokines. **PURPOSE:** Our purpose was to determine if there is an increased production of NO in patients receiving IL-2 tumor immunotherapy, and, if so, whether increases in NO production correlate with hemodynamic instability. **METHODS:** Twelve patients undergoing immunotherapy trials with IL-2 and anti-CD3 monoclonal antibody-activated lymphocytes (T-AK cells) were studied. Plasma levels of nitrate (NO₃⁻), the stable end metabolic product of NO synthesis, were measured before and at the end of IL-2 treatment cycles. **RESULTS:** We observed a ninefold increase in plasma levels of NO₃⁻ in patients after 7 days of treatment ($p < .0001$). A significant decrease in both systolic and diastolic blood pressures was observed in all patients ($p < .001$). **CONCLUSIONS:** We propose that mediated induction of NO synthase enzyme leads to progressive increases in NO production which, in turn, produces clinically significant hypotension. **IMPLICATIONS:** Since NO synthesis can be competitively inhibited by L-arginine analoges, a possible pharmacologic modulation of NO production could potentially contribute to better management of toxic side effects seen in IL-2 cancer therapies.

Summary

Patients receiving tumor immunotherapy with interleukin-2 (IL-2) may develop a reaction characterized by hypotension and a hyperdynamic response with low systemic vascular resistance, similar to that seen in severe infection. Nitric oxide had recently been identified as important in the regulation of blood pressure through relaxing effects on vascular smooth muscle (previously known as endothelial-derived relaxing factor). Nitric oxide was known to be produced in response to cytokines by many cell types. This study investigated the production of nitric oxide breakdown products in patients treated with IL-2 as part of their tumor immunotherapy, and related this to any hemodynamic changes. Plasma concentrations of nitrate were measured before and at the end of IL-2 treatment cycles in 12 patients undergoing immunotherapy trials with IL-2 and anti-CD3 monoclonal antibody-activated lymphocytes (T-AK cells). Increases in nitrate concentrations were seen in all patients after 7 days of treatment, associated with significant decreases in both systolic and diastolic blood pressures. The authors suggested that IL-2-induced nitric oxide release was responsible for clinically significant hypotension. They also noted that as nitric oxide synthase activity can be inhibited by substrate analoges, therapeutic intervention with such inhibitors might be useful in preventing the toxic side effects of IL-2 cancer therapies.

Citation count 128

Related references

1. Kilbourn RG, Fonseca GA, Trissel LA, Griffith OW. Strategies to reduce side effects of interleukin-2: evaluation of the antihypotensive agent NG-monomethyl-L-arginine. *Cancer J Sci Am* 2000; **6**: S21–S30.
2. Kilbourn RG, Fonseca GA, Griffith O *et al.* N^G-methyl-L-arginine, an inhibitor of nitric oxide synthase, reverses interleukin-2-induced hypotension. *Crit Care Med* 1995; **23**: 1018–1024.
3. Preiser JC, Zhang H, Wachel D, Boeynaems JM, Buurman W, Vincent JL. Is endotoxin-induced hypotension related to nitric oxide formation? *Eur Surg Res* 1994; **26**: 10–18.

Key message

The hypotension seen in some patients receiving cytokine chemotherapy is associated with increased levels of the breakdown products of nitric oxide.

Strengths

The limitations of circulating nitrate as a marker of nitric oxide production were recognized by the authors.

Weaknesses

Nitrate and nitrite in the circulation may also come from dietary sources, and interfere with interpretation of results. The authors also recognized that nitrate concentrations are highly dependent upon renal function, and the degree of renal dysfunction, seen in all patients by day 7 of IL-2 treatment, correlated with maximal nitrate levels. Three patients had previously had unilateral nephrectomies, and, unsurprisingly, had higher circulating nitrate levels.

Relevance

This paper was able to suggest a mechanism for the hemodynamic changes seen in some patients undergoing cytokine therapy, and was relevant to septic shock, in that increased cytokine concentrations already observed in such patients may also mediate hypotension via increased generation of nitric oxide. The authors suggested that hypotension in cancer patients receiving IL-2 could be treated with nitric oxide inhibitors, and early studies in three patients were promising. A recent study of 23 patients suggested that the arginine analog N^G-monomethyl-L-arginine can attenuate hypotension, but at the expense of cardiac output in some patients.

Title

Consensus conference definitions for sepsis, septic shock, acute lung injury, and acute respiratory distress syndrome: time for a re-evaluation

Author

Abraham E, Matthay MA, Dinarello CA, Vincent JL, Cohen J, Opal SM, Glauser M, Parsons P, Fisher CJ Jr, Repine JE

Reference

Crit Care Med 2000; **28**: 232–235

Abstract

Definitions for sepsis, septic shock, acute lung injury (ALI), and acute respiratory distress syndrome (ARDS) were developed by consensus conferences with the goal of achieving standardization of terminology and improved homogeneity of patient populations in clinical studies. Although such definitions have been useful in epidemiologic investigations, the criteria specified by the consensus conferences are broad and insufficiently specific to address the problem of heterogeneous mechanisms leading to clinical syndromes. An important challenge is to progress from clinical syndromes, as presently defined, to more specific entities that are delineated by alterations in specific immunologic or biochemical pathways. Such mechanistic definitions will provide more homogeneous groups of patients who can be identified at early stages of their clinical course. This approach encourages focused investigation of pathways leading to organ system dysfunction and death and, also, provides an efficient framework for the development of new therapies useful in critically ill patients.

Summary

Definitions for sepsis, septic shock, acute lung injury, and acute respiratory distress syndrome had been agreed upon several years previously, after consensus conferences with the aim of achieving standard terminology and more homogeneous patient populations in clinical studies. Although these definitions have been widely used, the criteria specified by the original consensus conferences were broad. These authors considered the criteria to be insufficiently specific when attempting to address the various mechanisms leading to clinical syndromes, particularly with regard to alterations in specific immunological and biochemical pathways. This paper is essentially a viewpoint of several eminent critical care specialists, who propose that revised mechanistic definitions will enable the identification of more homogeneous groups of patients at early stages of their clinical course. This approach may encourage focused investigation of pathways leading to organ system dysfunction and death, and provide an efficient framework for the development of new therapies useful in critically ill patients.

Citation count 120

Related references

1. Bone RC, Balk RA, Cerra FB *et al.* Definitions for sepsis and organ failure and guidelines for the use of innovative therapies in sepsis. The ACCP/SCCM Consensus Conference Committee. American College of Chest Physicians/Society of Critical Care Medicine. *Chest* 1992; **101**: 1644–1655.
2. Bone RC. Let's agree on terminology: definitions of sepsis. *Crit Care Med* 1991; **19**: 973–976.

Key message

Previous clinical trials of immunotherapies in critical care may have failed due to heterogeneous patient populations. The use of more rigid definitions based on, for example, cytokine levels, may permit the successful development of new therapies in critical care.

Strengths

Ten eminent critical care specialists have contributed to this article, representing expertise in Europe and the United States. There is considerable circumstantial evidence to support the proposed concepts.

Weaknesses

The paper is an opinion article, there are no data directly supporting the authors' suppositions.

Relevance

Recent studies of new pharmacological therapies and immunotherapies in patients with sepsis, septic shock, acute lung injury, and acute respiratory distress syndrome have not shown benefit. One explanation is that the mechanisms leading to these syndromes studied were so heterogeneous that even though an agent may have had a positive therapeutic effect in a limited group, such benefit was diluted and not detectable in the overall study population. Understanding of the biochemical and inflammatory mechanisms which result in organ function after infection, shock, trauma, aspiration, and other causes has increased such that the incorporation of such information to produce new definitions may identify critically ill patients who are more likely to respond to novel therapies.

Pediatric critical care

Bradley P. Fuhrman MD

Introduction

Each classic paper in this chapter reports a novel development that has had a major impact on the field of pediatric critical care. In the area of respiratory support, pediatric critical care has been a fertile source of ideas that have had applications in adults. Gregory *et al.* introduced 'continuous positive airway pressure' to meet the specific need for lung recruitment of surfactant-deficient premature infants, babies below the size limit for safe and atraumatic mechanical ventilation at that time. This technology led to the development of ventilator weaning modes for patients of all ages. Bartlett *et al.* modified operating room technology to introduce extracorporeal membrane oxygenation (ECMO) into the ICU. It has now been shown that ECMO reduces mortality in neonates. A limited number of centers offer such support to adults. Surfactant deficiency ultimately proved treatable by exogenous surfactant administration – Fujiwara *et al.* pioneered that approach in 1980. Surfactant therapy has not yet been shown to be effective in the surfactant dysfunction state of acute respiratory distress syndrome (ARDS), but there are enthusiasts who believe it will play a role in adult intensive care. Halothane anesthesia was borrowed from the operating room for the treatment of asthma in the pediatric ICU by Crone *et al.* in 1982. Other inhalational anesthetics have followed. In 1988, McCulloch *et al.* presented the first convincing evidence that lung recruitment protects the atelectasis-prone lung from trauma during mechanical ventilation. Their report focused on high frequency oscillatory ventilation, but the principle they espoused is relevant to all lung protective strategies. Kinsella *et al.* introduced inhaled nitric oxide into critical care for the treatment of persistent pulmonary hypertension of the newborn. Although not yet approved for use in adults, NO has potential adult applications. It is noteworthy that FDA approval of new drugs usually bypasses pediatric efficacy testing. Surfactant, NO, and HFOV earned pediatric approval at the outset. So did prostaglandin E-1 (PGE-1) for dilation of the ductus arteriosus (Heymann *et al.*), a drug that has changed the nature of pediatric cardiology and infant heart surgery.

Pediatrics has its unique challenges. We have virtually stamped out Reye's syndrome, thanks in part to the report of Starko *et al.*, and hope to greatly reduce the incidence of the shaken baby syndrome, thanks largely to its easy recognition (Caffey 1974). And when we improve therapy, Pollack *et al.* have shown that we can measure it with physiological acuity scales like the PRISM score.

Title

Treatment of the idiopathic respiratory-distress syndrome with continuous positive airway pressure

Author

Gregory GA, Kitterman JA, Phibbs RH, Tooley WH, Hamilton WK

Reference

N Engl J Med 1971; **284**: 1333–1340

Abstract

Not available

Summary

These authors were the first to report the use of continuous positive airway pressure (CPAP) to treat infants with 'idiopathic respiratory-distress syndrome' (IRDS). Up to 12 mmHg of CPAP was delivered during spontaneous breathing, either by endotracheal tube or by using a chamber placed around the infant's head. Arterial oxygen tension increased in all 20 infants, reducing oxygen requirement by an average of 37.5% within 12 hours. Although minute ventilation decreased, there was little effect on arterial carbon dioxide tension, pH, arterial blood pressure, or lung compliance. Sixteen infants survived, including seven of 10 weighing <1500 g at birth.

Citation count

710

Related references

1. Delivoria-Papadopoulos M, Levison H, Swyer PR. Intermittent positive pressure respiration as a treatment in severe respiratory distress syndrome. *Arch Dis Child* 1965; **40**: 474–479.
2. Reid DHS, Tunstall ME, Mitchell RG. A controlled trial of artificial respiration in the respiratory-distress syndrome of the newborn. *Lancet* 1967; **I**: 532–533.
3. Tunstall ME, Cater JL, Thomson JS *et al*. Ventilating the lungs of newborn infants for prolonged periods. *Arch Dis Child* 1968; **43**: 486–497.

Key message

The pathophysiology of the idiopathic respiratory distress syndrome had not, at the time, been completely defined. Yet Gregory *et al.* devised a physiological recruitment strategy that coped effectively with the surface tension abnormality of surfactant deficiency by increasing alveolar radius and reversing atelectasis. At the time of this publication, mechanical ventilation for IRDS was, at best, a high-risk undertaking. Ventilators of the time were ill-equipped to cope with the small, stiff, friable lung of the premature infant. CPAP, as it came to be called, separated the need to ventilate from the need for alveolar recruitment.

Why it's important

This publication illustrated the independent value of lung recruitment in treatment of IRDS, a strategy which turned out to be equally important for other forms of low functional residual capacity lung disease. It laid a foundation for open lung strategies to come.

Strengths

This therapeutic trial was undertaken at a time when little was available to treat infants with surfactant deficiency. It was consequently dramatic in its impact.

Weaknesses

The report does not fit current standards for highest quality evidence-based medicine. It is not a controlled, randomized trial. Instead, it rests its case on widely understood historical outcomes.

Relevance

Thirty years later, although often combined with other therapies (including the administration of exogenous surfactant), CPAP remains a valued respiratory therapy and is the prototypic open lung strategy.

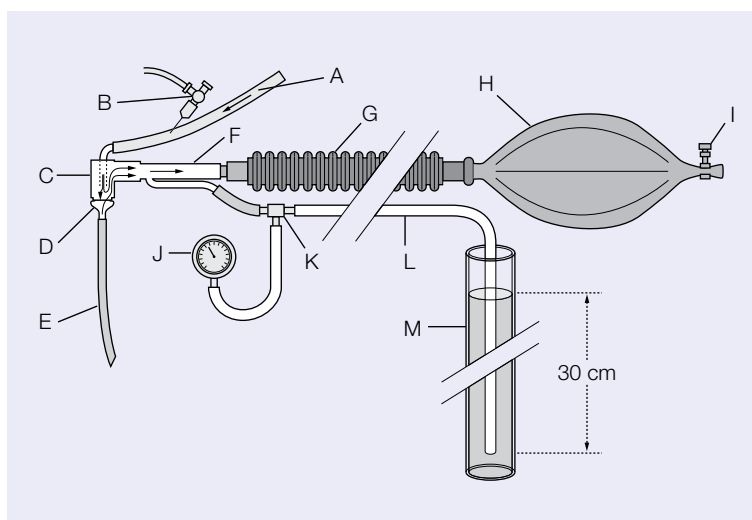

Fig. 21-1. System for applying continuous positive airway pressure through an endotracheal tube A represents gas inflow, B oxygen sampling port, C Norman elbow (modified T piece), D endotracheal-tube connector, E Endotracheal tube, F Sommers T piece, G corrugated anesthesia hose, H reservoir bag (500 ml) with open tail piece, I screw clamp, J aneroid pressure manometer, K plastic T connector, L plastic tubing (1 cm internal diameter), and M underwater "pop-off". Arrows indicate direction of gas flow.

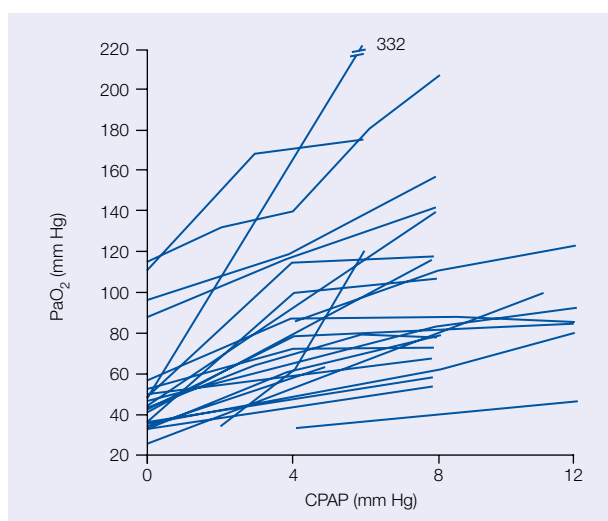

Fig. 21-2. Relation of PaO_2 to CPAP therapy in infants with IRDS

Title

Extracorporeal membrane oxygenator support for cardiopulmonary failure: experience in 28 cases

Author

Bartlett RH, Gazzaniga AB, Forg SW, Jefferies MR, Roohk HV, Haiduc N

Reference

J Thorac Cardiovasc Surg 1977; **73**: 375–386

Abstract

We used extracorporeal membrane oxygenation (ECMO) for 28 patients (14 children and 14 adults) over a 5 year period. Nine patients improved on ECMO and five were long-term survivors. ECMO was used for pulmonary insufficiency in 24 patients. Initially, only moribund patients were treated, but recently the combination of open lung biopsy and pulmonary insufficiency index (PII) has been used to select patients. The best results have been obtained in newborn cases and the adult capillary leak syndromes; the major problem has been progression to fibrosis despite ECMO support. ECMO was used for cardiac failure in four patients. Children with postoperative cardiac failure did the best; profound shock was not reversed with venoarterial bypass. ECMO support is lifesaving in selected cases of pulmonary insufficiency. Initial trials in cardiac failure and the infant age group in this series suggest that ECMO will have an even greater role in those applications.

Summary

The authors used extracorporeal membrane oxygenation (ECMO) to treat 28 patients (14 children and 14 adults). Nine patients improved on ECMO, and five were long-term survivors. ECMO was used for pulmonary insufficiency in 24 patients. Initially, only moribund patients were treated, but later a combination of open lung biopsy and pulmonary insufficiency index were used to select patients. Best results were in neonates and in adults with capillary leak syndromes. ECMO was found to be lifesaving in selected patients with respiratory failure, and especially in infants. Although it was shown to be technically feasible as a form of prolonged cardiopulmonary support, risk of intracranial bleeding was found to be substantial. Reversibility of the underlying disorder was found to be critical to appropriate patient selection.

Citation count 72

Related references

1. Galletti PM, Hopf MA, Brecker GA. Problems associated with long-lasting heart-lung bypass. *Trans Am Soc Artif Intern Organs* 1960; **6**: 180.
2. O'Rourke PP, Crone RK, Vacanti JP *et al*. Extracorporeal membrane oxygenation and conventional medical therapy in neonates with persistent pulmonary hypertension of the newborn: a prospective randomized study. *Pediatrics* 1989; **84**: 957–963.
3. UK Collaborative ECMO Trial Group. UK Collaborative Randomized Trial of Neonatal Extracorporeal Membrane Oxygenation. *Lancet* 1996; **348**: 75–82.

Key message

ECMO was shown to be technically feasible, and to offer hope of recovery from life-threatening cardiopulmonary disease when the underlying process was reversible. Potential opportunities to improve survival were identified within the neonatal population.

Why it's important

This publication was the first detailed compilation of clinical applications of this new technology. It identified as a target for treatment, reversible neonatal cardiorespiratory disease. Twenty years after this publication, a randomized controlled trial of ECMO in neonates (UK collaborative trial, reference 3 above) established that ECMO did, indeed, improve outcome in this population.

Strengths

The authors treated a group of patients not expected to survive, and gave reason to believe that their underlying disorders, if potentially reversible, were not hopeless.

Weaknesses

Patients were not randomized.

Relevance

The neonatal diseases that seemed most amenable to ECMO therapy in 1976 now have new treatment options. Yet ECMO still plays a role in the management of failures of those newer modalities. In fact, none of those newer treatments have been compared to ECMO in randomized trials, and none are likely to be, because ECMO would be the essential cross-over treatment. The principle that ECMO may allow reversible cardiopulmonary disease to remit still guides patient selection. Neonatal cardiac indications and pediatric septic shock are increasingly treated by ECMO at larger centers.

Title

Artificial surfactant therapy in hyaline-membrane disease

Author

Fujiwara T, Maeta H, Chida S, Morita T, Watabe Y, Abe T

Reference

Lancet 1980; **1**: 55–59

Abstract

Ten preterm infants severely ill with hyaline-membrane disease (HMD) were given artificial surfactant endotracheally. Oxygenation and alveolar-arterial oxygen gradients improved, the levels of inspired oxygen and peak respirator pressure could be reduced, and many of the radiological abnormalities resolved. Acidosis and systemic hypotension were also reversed. In nine infants, a patent ductus arteriosus became evident after recovery from HMD, necessitating further assisted ventilation. Eight infants survived, including five of six with birthweight less than 1500 g; two died of unrelated causes. Postnatal tracheal instillation of artificial surfactant may prove a useful treatment for severe HMD.

Summary

Ten preterm infants that were severely ill with hyaline-membrane disease (HMD) were given artificial surfactant endotracheally. Oxygenation and alveolar-arterial oxygen gradients improved, the levels of inspired oxygen and peak respirator pressure could be reduced, and many of their radiological abnormalities resolved. Acidosis and systemic hypotension were also reversed. Eight infants survived, including five of six with birth weight <1500 grams.

Citation count 487

Related references

1. Avery EM, Mead J. Surface properties in relation to atelectasis and hyaline membrane disease. *Am J Dis Child* 1959; **97**: 517.
2. Fujiwara T, Maeta H, Chida S, Morita T. Improved pulmonary pressure-volume characteristics in premature newborn rabbits after tracheal instillation of artificial surfactant. *IRCS Med Sci* 1979; **7**: 312.
3. Fujiwara T, Maeta H, Chida S, Morita T. Improved lung-thorax compliance and prevention of neonatal pulmonary lesion in prematurely delivered rabbit neonates subjected to IPPV after tracheal instillation of artificial surfactant. *IRCS Med Sci* 1979; **7**: 313.

Key message

Hyaline membrane disease, a deficiency state of the premature infant in which pulmonary surfactant is not elaborated by the lung, may be treated by endotracheal instillation of an artificial mixture with surfactant properties. The authors developed such a mixture in their laboratory, tested it in prematurely delivered rabbits, and here report its use in a series of ten premature neonates. Manifestations of surfactant deficiency were relieved in most patients. Survival was greatly improved compared with historical controls.

Why it's important

Surface tension abnormalities had been known to underlie the respiratory distress syndrome of premature infants from the time of Avery and Mead's 1959 publication (1). Yet, successful treatment of HMD by replacement therapy had not been accomplished in humans. Mortality of low birth weight premature infants remained quite high, despite improvements in supportive care, and the introduction of both manual and mechanical assisted ventilation for HMD. This report ushered in the era of surfactant replacement therapy.

Strengths

A clear improvement in physiology was shown using each patient as his own control. No comparison group was needed, as no alternative therapy existed.

Weaknesses

None of importance.

Relevance

Surfactant deficiency is one of the most obvious threats to survival of the premature infant. Surfactant replacement therapy has dramatically changed neonatal mortality. Although new products (mostly derived from animal lungs) have largely replaced artificial surfactants, this report paved the way for surfactant replacement.

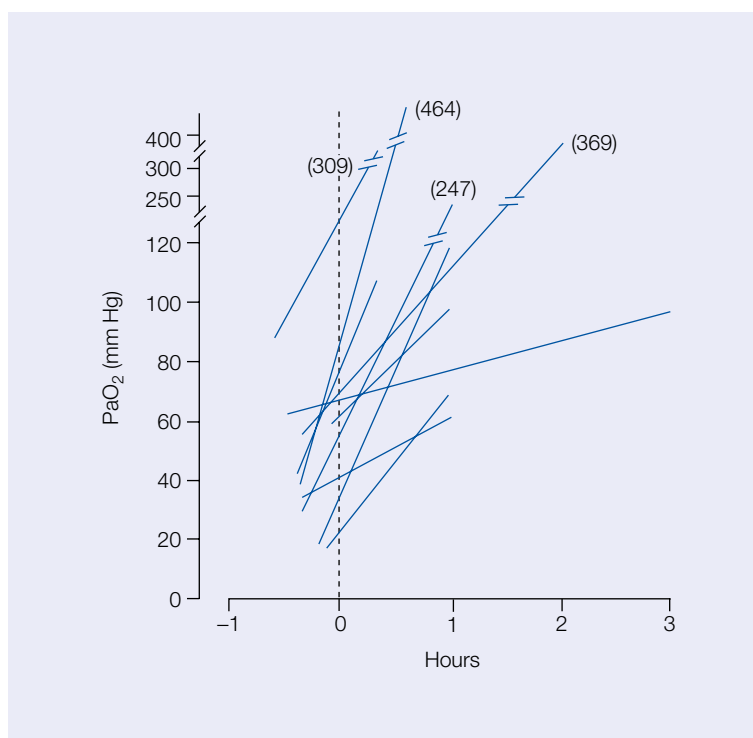

Fig. 21-3. Changes in PaO₂ within 45 minutes before and within 3 hours after administration of artificial surfactant

Title

Halothane in status asthmaticus

Author

O'Rourke PP, Crone RK

Reference

Crit Care Med 1982; **10**: 341–343

Abstract

The authors administered halothane anesthesia to treat a child with status asthmaticus that was refractory to conventional pharmacological therapy and mechanical ventilation. Halothane is an inhalation anesthetic with potent bronchodilator properties. Marked improvement in gas exchange occurred in this patient after 10 minutes of treatment with halothane. The pharmacology of halothane is reviewed, and a possible role for its use in childhood asthma is proposed.

Summary

This report describes administration of halothane anesthesia to treat a child with status asthmaticus that was refractory to conventional pharmacological therapy and mechanical ventilation in the pediatric ICU. Marked improvement in gas exchange occurred after 10 minutes of treatment. A possible role for halothane in the ICU management of status asthmaticus was proposed.

Citation count 56

Related references

1. Shnider SM, Papper EM. Anesthesia for the asthmatic patient. *Anesthesiology* 1961; **22**: 886.
2. Adriani J, Rovenstine EA. The effect of anesthetic drugs upon bronchi and bronchioles of excised lung tissue. *Anesthesiology* 1943; **4**: 253.
3. Hirshman C, Bergman N. Halothane and Enflurane protect against bronchospasm in an asthma dog model. *Anesth Analg* 1978; **57**: 629–633.

Key message

Status asthmaticus may be terminated by the use of smooth muscle relaxing anesthetics. Halothane, which is easy to use in the ICU, offers a non-adrenergic means to break bronchoconstriction.

Why it's important

Asthma is a common pediatric condition that may suddenly cause life-threatening respiratory failure. Cardiac effects limit the use of adrenergic agents, even those relatively 'specific' for bronchial smooth muscle. Intubation and mechanical ventilation do not, alone, relieve the airway obstruction of asthma. This report paved the way for the use of inhalational anesthetic agents in the treatment of life-threatening status asthmaticus.

Strengths

The authors stole shamelessly from anesthesia, an allied field to intensive care. This use of anesthesia was widely recognized in the operating room. Unlike stealing cardiac bypass technology to bring extracorporeal membrane oxygenation to the ICU, this theft was simple and straightforward.

Weaknesses

The communication is a single case report. It succeeds because it is striking.

Relevance

Status asthmaticus remains a life-threatening disorder. Use of anesthetics for the management of intubated asthmatics has become common.

Title

Lung volume maintenance prevents lung injury during high frequency oscillatory ventilation in surfactant-deficient rabbits

Author

McCulloch PR, Forkert PG, Froese AB

Reference

Am Rev Respir Dis 1988; **137**: 1185–1192

Abstract

Controversy exists whether high frequency oscillatory ventilation with an active expiratory phase (HFO-A) should be used at low ventilator pressures or high alveolar volumes to minimize lung injury in the atelectasis-prone lung. We therefore ventilated 20 anesthetized, tracheostomized rabbits made surfactant-deficient by lung lavage in one of three ways: HFO-A at a high lung volume (HFO-A/HI), HFO-A at a low lung volume (HFO-A/LO), or conventional mechanical ventilation (CMV); all received 100% oxygen for 7 hours. We examined oxygenation, lung mechanics, and lung pathology. Arterial oxygenation in the HFO-A/HI rabbits was kept greater than 350 mmHg. Mean lung volume above FRC in these animals was 23.4 ml/kg. In rabbits ventilated with HFO-A/LO and CMV, arterial oxygen tensions were 70 to 100 mmHg. Mean lung volumes were 7.8 and 4.3 ml/kg, respectively. Total respiratory system pressure-volume curves (P-V curves) showed no change from baseline in the HFO-A/HI group after 7 hours of ventilation. The low lung volume groups (HFO-A/LO and CMV) showed a diminution in hysteresis of their P-V curves, lower total respiratory system compliance, more hyaline membranes, and severe airway epithelial damage. All changes were significant with *p* less than 0.05. We conclude that maintenance of alveolar volume is a key mechanism in the prevention of lung injury during mechanical ventilation of the atelectasis-prone lung. For optimal outcome using high frequency oscillatory ventilation, alveoli must be actively reexpanded and then kept expanded using appropriate mean airway pressures.

Summary

This report dealt with a critical controversy as to whether high frequency oscillatory ventilation (HFOV) with an active expiratory phase should be used at low ventilator pressures or at high alveolar volumes to minimize lung injury in the atelectasis-prone lung. Twenty rabbits were made surfactant-deficient by repeated lung lavage, then randomized to one of three groups: (1) HFOV at high mean airway pressure, (2) HFOV at low mean airway pressure, or (3) conventional mechanical ventilation at 8 cm H₂O PEEP. Gas exchange, lung mechanics, and histopathology were studied. Oxygenation data, pressure-volume curves, and histology all showed benefit of HFOV at high mean airway pressure (high lung volume).

Citation count

222

Related references

1. Hamilton PP, Onayemi A, Smyth JA *et al.* Comparison of conventional and high-frequency ventilation: oxygenation and lung pathology. *J Appl Physiol* 1983; **55**: 131–138.
2. Kolton M, Cattran CB, Kent G, Volgyesi G, Froese AB, Bryan AC. Oxygenation during high frequency ventilation compared with conventional mechanical ventilation in two models of lung injury. *Anesth Analg* 1982; **61**: 323–332.

3. Bryan AC, Slutsky AS. Lung volume during high frequency oscillation. *Am Rev Respir Dis* 1986; **133**: 928–930.

Key message

The atelectasis-prone lung (low functional residual capacity (FRC) disease) is subject to injury during mechanical ventilation. To prevent lung injury during HFOV, the lung must be opened (recruited) and kept open during treatment. HFOV should be performed at relatively high lung volume to avoid volutrauma.

Why it's important

HFOV is an effective means to support the patient with lung disease because an open lung can be achieved during HFOV without excessive peak airway pressure. HFOV technology would have been cast aside had this not been appreciated.

Strengths

The study is a well-designed, carefully analyzed investigation.

Weaknesses

None of significance.

Relevance

Keeping the lung open as a protective strategy promises to reduce morbidity and mortality from mechanical ventilation of the patient with low FRC disease. Whereas the adult strategy for opening the lung is currently directed at high PEEP, low tidal volume, and tolerance of elevated $p\text{CO}_2$, infants and children are often supported using the open lung algorithm for HFOV.

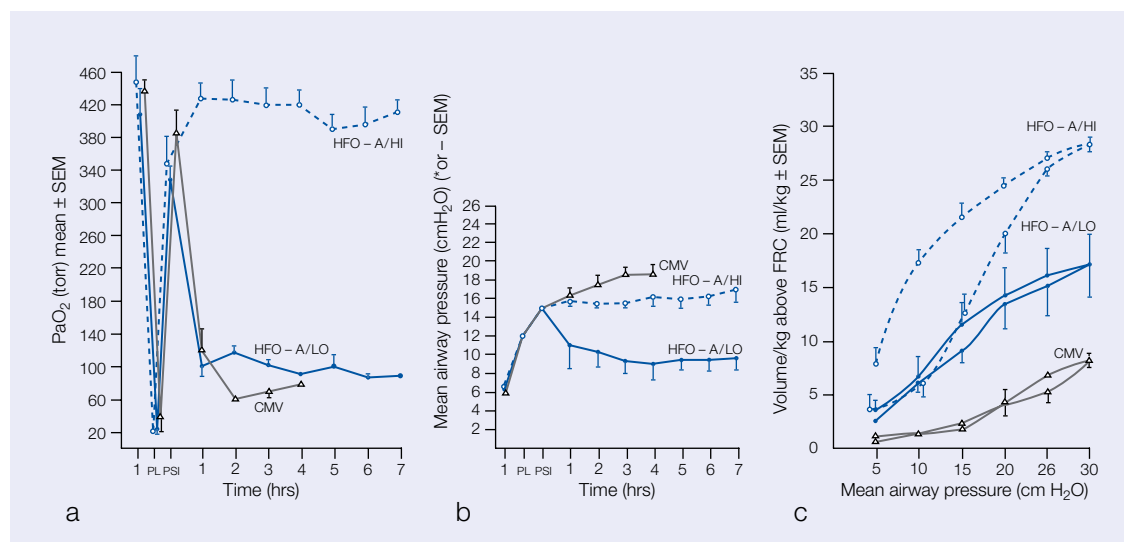

Fig. 21-4. (a). Time course of oxygenation in 3 experimental subgroups: CMV = conventional mechanical ventilation; HFO-A = high frequency oscillation ventilation; I = initial control time period; PL = postlavage; PSI = postsustained inflation; HI = high lung volume; LO = low lung volume; Note there are no intergroup differences prior to randomization. (b). Time course of mean airway pressure in the 3 experimental subgroups. Pressure levels were not different between CMV and A/Ht. mean airway pressures were significantly lower during HFO-A/LO from 2 to 7 h. (c). Respiratory system pressure-volume curves obtained at the end of the experimental periods of ventilation. Note the significant intergroup differences in total respiratory compliance and hysteresis

Title

Low-dose inhalation nitric oxide in persistent pulmonary hypertension of the newborn

Author

Kinsella JP, Neish SR, Shaffer E, Abman SH

Reference

Lancet 1992; **340**: 819–820

Abstract

We studied the effects of inhaled nitric oxide (NO) in nine newborn infants with severe persistent pulmonary hypertension (PPHN) who were candidates for extracorporeal membrane oxygenation treatment. With low doses of NO (10–20 ppm), all showed rapid improvement in oxygenation without reduction of systemic blood pressure. In six infants treated with inhaled NO for 24 hours, clinical improvement was sustained at 6 ppm.

Summary

The authors studied the effects of inhaled nitric oxide (NO) in nine newborn infants with severe persistent pulmonary hypertension (PPHN) who were candidates for extracorporeal membrane oxygenation treatment. All showed rapid improvement in oxygenation without reduction of systemic blood pressure.

Citation count 501

Related references

1. Levin DL, Heymann MA, Kitterman JA *et al*. Persistent pulmonary hypertension of the newborn. *J Pediatr* 1976; **89**: 626–630.
2. Roberts JD Jr, Polaner DM, Todres ID, Lang P, Zapol WM. Inhaled nitric oxide (NO): a selective pulmonary vasodilator for the treatment of persistent pulmonary hypertension of the newborn (PPHN). *Circulation* 1991; **84**: A127.
3. Abman SH, Chatfield BA, Hall SL, Mcmurtry IF. Role of EDRF during transition of pulmonary circulation at birth. *Am J Physiol* 1990; **259**: H1921–H1927.

Key message

In PPHN, oxygenation can be dramatically improved by inhalation of nitric oxide, a gas generated endogenously by normal vascular endothelium and now known to be the endothelium-derived relaxation factor (EDRF). This physiological change (pulmonary vasodilation) may alter the course of PPHN, which is generally a self-limiting disease.

Why it's important

PPHN, one of the final common pathways of neonatal illness, is generally self-limiting, and this simple means to reverse its physiology has changed both the treatment and (probably) the outcome of the disorder.

Strengths

The report is a patient series, without controls. Its importance rests on the dramatic change in oxygenation demonstrated by the trial.

Weaknesses

No control group.

Relevance

Neonates frequently follow a final common pathway of hypoxia, pulmonary vasoconstriction, right-to-left shunting, and worsening hypoxia. Inhaled nitric oxide often breaks this cycle, and has become a mainstay of treatment of PPHN.

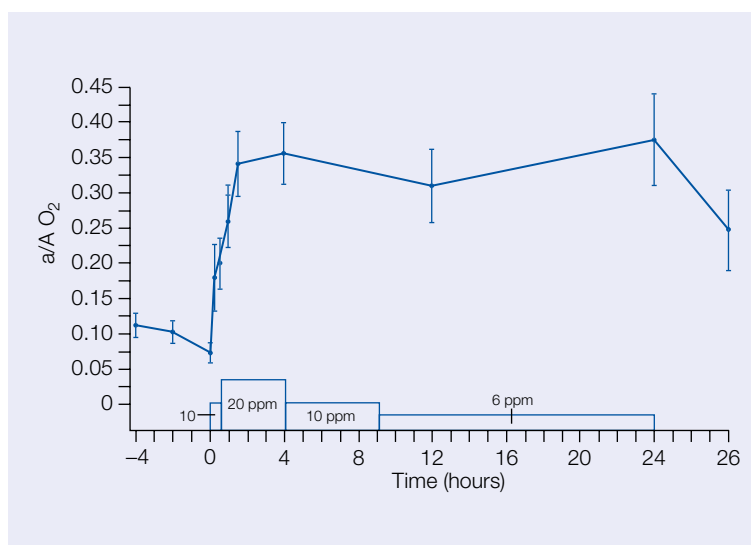

Fig. 21-5. Serial changes in arterial/alveolar oxygen tension ratio (a/AO_2) for patients over 24h of NO inhalation

Title

The whiplash shaken infant syndrome: manual shaking by the extremities with whiplash-induced intracranial and intraocular bleedings, linked with residual permanent brain damage and mental retardation

Author

Caffey J

Reference

Pediatrics 1974; **54**: 396–403

Abstract

Not available

Summary

This paper described the essential clinical features of the 'whiplash shaken infant syndrome'. Caffey, then a pediatric radiologist at the Children's Hospital of Pittsburgh, summarized pathological, radiographical, and neurological evidence that shaking alone can cause intracranial hemorrhage, intraocular bleeding, periosteal injury, death, or retardation.

Citation count

277

Related references

1. Caffey J. Multiple fractures in the long bones of infants suffering from subdural hematoma. *Am J Roentgen* 1946; **56**: 163.
2. Caffey J. On the theory and practice of shaking infants, its potential residual effects of permanent brain damage and mental retardation. *Am J Dis Child* 1972; **124**: 161–169.
3. Mushin AS, Morgan G. Ocular damage in the battered babe syndrome. *Br J Ophthalmol* 1971; **55**: 343–347.

Key message

The severity of the whiplash injury is attributable to characteristics of the infant that make it especially vulnerable to this form of abuse: the relatively heavy head, weak neck muscles, soft and deformable characteristics of the (as yet) unmyelinated infant brain, large and deformable fontanelles, and fixed attachments of bridging veins to the falx and sagittal sinus. The absence of bruising and superficial signs of trauma makes this form of abuse especially insidious. Caffey emphasized the significance of retinal hemorrhages and the importance of the fundoscopic examination in evaluation of the infant with neurological abnormalities or unexplained morbidity.

Why it's important

Identifying this constellation of findings and its cause, then labelling it a syndrome, taken together make this condition preventable. The 'shaken baby syndrome' remains one of the most important causes of infantile, acute, life-threatening events. It commonly results in pediatric ICU admission, death, or retardation. It is readily diagnosed by using modern technology to image the brain and simple optics to view the fundi. It is critical that this diagnosis is not missed because of its implications for long-term survival, both of the victim and of others exposed to the perpetrator.

Strengths

This paper simply yet critically described the syndrome in such a way that it might be readily diagnosed.

Weaknesses

It presents case reports, but does not compile the findings to ease the reader's analysis of content.

Relevance

Although still with us, the pathogenesis set forth by Caffey makes the syndrome comprehensible to parents and caregivers. Recent trials of educational interventions suggest that this form of child abuse may be largely preventable.

Title

Ductus arteriosus dilation by prostaglandin E1 in infants with pulmonary atresia

Author

Heymann MA, Rudolph AM

Reference

Pediatrics 1977; **59**: 325–329

Abstract

Infants with pulmonary atresia depend on patency of the ductus arteriosus for survival in the immediate postnatal period. Despite continuing hypoxemia after birth, the ductus arteriosus usually constricts, thus reducing pulmonary blood flow. This often occurs while awaiting surgical palliation or correction, leading either to marked deterioration in the infant's condition, or death. In ten infants with pulmonary atresia, we infused prostaglandin E1 (PGE1) at a rate of 0.1 µg/kg/min in six, and 0.05 µg/kg/min in four, into the descending aorta at the orifice of the ductus arteriosus. The ductus arteriosus was effectively dilated; at the narrowest point, the diameter, measured in eight infants, almost doubled. In all ten infants, arterial blood PO₂ increased, averaging 24.6 mmHg before, and 43.7 mmHg after the infusion was started. Infusion of PGE1 directly into the aorta adjacent to the ductus arteriosus avoided the complications of pyrexia, muscular twitching, and excitability, which may be related to the effects of prostaglandins on the central nervous system.

Summary

Infants with pulmonary atresia depend on patency of the ductus arteriosus for survival in the immediate postnatal period. Despite continuing hypoxemia after birth, the ductus arteriosus usually constricts, thus reducing pulmonary blood flow. This often occurs while awaiting surgical palliation or correction, leading either to marked deterioration in the infant's condition, or death. In ten infants with pulmonary atresia, the authors infused prostaglandin E1 (PGE-1) at a rate of 0.1 µg/kg/min. The ductus arteriosus was effectively dilated. Diameter at the narrowest point almost doubled. Arterial pO₂ increased from 25 mmHg to 44 mmHg after starting the infusion.

Citation count 92

Related references

1. Coceani F, Olley PM. The response of the ductus arteriosus to prostaglandins. *Can J Physiol Pharmacol* 1973; **51**: 220–225.
2. Elliott RB, Starling MB, Neutze JM. Medical manipulation of the ductus arteriosus. *Lancet* 1975; **1**: 140–142.
3. Olley PM, Coceani F, Bodach E. E-type prostaglandins: a new emergency therapy for certain cyanotic congenital heart malformations. *Circulation* 1976; **53**: 728–731.

Key message

Pulmonary atresia is a prototypic form of ductus-dependent cardiac disease. Reopening the constricting ductus and restoring adequate pulmonary blood flow may palliate this heart defect. This can be accomplished at minimal risk by simple intravenous infusion of the drug.

Why it's important

Ductus-dependent congenital cardiac defects of all types may potentially be palliated in this fashion. The list of conditions amenable to this therapy includes cyanotic defects like pulmonary atresia, transposition, and tricuspid atresia, as well as obstructive defects that present with shock at the time of ductus closure, such as coarctation, hypoplastic left heart syndrome, and interruption of the aortic arch. That is not to say that surgical palliation is no longer needed. Palliative and corrective operations are still performed in the neonatal period, as PGE-1 treatment is only a temporary fix. Before the introduction of PGE-1 by Upjohn, these heart defects usually presented as surgical emergencies in the first few days of life. They were treated by urgent operations, usually after dark. The patient was typically acidotic, and in extremis from either hypoxia or from shock at the time of operation. Much of the subsequent improvement in surgical outcome for these defects is attributable to the benefits of PGE-1 palliation.

Strengths

This patient series provided a stunning demonstration of physiological improvement, which the clinician quickly translated to mean better outcome. Efficacy was shown by comparison of pre-infusion with post-infusion oxygenation.

Weaknesses

None of significance.

Relevance

Because of its excellent safety profile, PGE-1 has become a frontline therapy. This therapy is now initiated by emergency room, neonatology, and pediatric ICU physicians, and often by transport nurses, before the critically ill neonate is even seen by a cardiologist.

Title

Reye's syndrome and salicylate use

Author

Starko KM, Ray CG, Dominguez LB, Stromberg WL, Woodall DF

Reference

Pediatrics 1980; **66**: 859–864

Abstract

During an outbreak of influenza A, seven patients with Reye's syndrome and 16 ill classmate control subjects were evaluated for characteristics of the patients' prodromal illness and the control subjects illness, and for medication usage. Patients during the prodrome and control subjects had similar rates of sore throat, coryza, cough, headache, and gastrointestinal complaints, except for documented fever which occurred significantly more often in patients than in control subjects ($p = 0.05$). While medications which did not contain salicylate were taken as frequently by patients as control subjects, patients took more salicylate-containing medications than did control children ($p < 0.01$). All seven patients took salicylate, whereas only eight of 16 control subjects did so ($p < 0.05$). Patients took larger doses of salicylate than did the entire control group ($p < 0.01$). When the eight control subjects who took salicylate were compared with the patients, the patients still tended to take larger doses ($p = 0.08$). Patients with fever took salicylate more frequently than control subjects with fever ($p < 0.01$). In addition, salicylate consumption was correlated with severity of Reye's syndrome ($p < 0.05$). It is postulated that salicylate, operating in a dose-dependent manner, possibly potentiated by fever, represents a primary causative agent of Reye's syndrome.

Summary

During an outbreak of influenza A, seven patients with Reye's syndrome and 16 ill classmate control subjects were evaluated for characteristics of their prodrome or illness, and for medication usage. Reye's patients during their prodrome and control subjects had similar rates of sore throat, coryza, cough, headache, and gastrointestinal complaints. Fever occurred more frequently in patients who subsequently developed Reye's syndrome ($p = 0.05$). All Reye's patients took salicylates, whereas only half of the controls did ($p < 0.05$). Salicylate dosage was greater in Reye's patients than in controls ($p < 0.01$), and severity of Reye's syndrome correlated with salicylate dose. The authors postulated that salicylate caused Reye's syndrome.

Citation count 221

Related references

1. Reye RDK, Morgan G, Baral J. Encephalopathy and fatty degeneration of the viscera: a disease entity in childhood. *Lancet* 1963; **2**: 749.
2. Partin JC, Schubert WK, Partin JS. Mitochondrial ultrastructure in Reye's syndrome (encephalopathy and fatty degeneration of the viscera). *N Engl J Med* 1971; **285**: 1339–1343.
3. Barrett MJ, Hurwitz ES, Schonberger LB, Rogers MF. Changing epidemiology of Reye syndrome in the United States. *Pediatrics* 1986; **77**: 598–602.

Key message

Salicylate usage is statistically, if not causally, related to the occurrence of Reye's syndrome. The authors recommended that, in light of this association, caution be exercised in giving salicylate to children with an otherwise benign illness.

Why it's important

In the 1970s, Reye's syndrome was moderately common, occurring in outbreaks corresponding to clusters of viral illness. It was sufficiently common that the authors were able to identify seven cases in Arizona in December 1978, all associated with influenza B. The syndrome was a scourge, carrying a 32% fatality rate. Subsequent to this report, salicylate use in children dropped precipitously, and so did the incidence of Reye's syndrome, now an exceedingly rare disease.

Strengths

The report used simple epidemiological methods and statistics to show, in a very small sample, a critically important relationship.

Weaknesses

None of significance.

Relevance

This report may be credited with near eradication of a life-threatening illness. It reminds us of the power of preventative medicine.

Title

Pediatric risk of mortality (PRISM) score

Author

Pollack MM, Ruttimann UE, Getson PR

Reference

Crit Care Med 1988; **16**: 1110–1116

Abstract

The Pediatric Risk of Mortality (PRISM) score was developed from the Physiologic Stability Index (PSI) to reduce the number of physiologic variables required for pediatric ICU (PICU) mortality risk assessment, and to obtain an objective weighting of the remaining variables. Univariate and multivariate statistical techniques were applied to admission day PSI data (1,415 patients, 116 deaths) from four PICUs. The resulting PRISM score consists of 14 routinely measured, physiologic variables, and 23 variable ranges. The performance of a logistic function estimating PICU mortality risk from the PRISM score, age, and operative status was tested in a different sample from six PICUs (1,227 patients, 105 deaths), each PICU separately, and in diagnostic groups using chi-square goodness-of-fit tests and receiver operating characteristic (ROC) analysis. In all groups, the number and distribution of survivors and nonsurvivors in adjacent mortality risk intervals were accurately predicted: total validation group ($\chi^2(5) = 0.80$; $p > .95$), each PICU separately ($\chi^2(5)$ range 0.83 to 7.38; all $p > .10$), operative patients ($\chi^2(5) = 2.03$; $p > .75$), nonoperative patients ($\chi^2(5) = 2.80$, $p > .50$), cardiovascular disease patients ($\chi^2(5) = 4.72$; $p > .25$), respiratory disease patients ($\chi^2(5) = 5.82$; $p > .25$), and neurologic disease patients ($\chi^2(5) = 7.15$; $p > .10$). ROC analysis also demonstrated excellent predictor performance (area index = 0.92 +/- 0.02).

Summary

This report documents the extraction of 14 physiological variables from the Physiologic Stability Index to develop a simpler predictor of risk of mortality in pediatric intensive care (the PRISM score). The relation of these variables to risk of mortality was determined in four pediatric ICUs. Using those relations, predictions of risk of mortality were made for six other pediatric ICUs, with a total of 1227 patients and 105 deaths. In all groups, the number and distribution of survivors and non-survivors were accurately predicted.

Citation count 510

Related references

1. Pollack MM, Yeh TS, Ruttimann UE *et al.* Evaluation of pediatric intensive care. *Crit Care Med* 1984; **12**: 376–383.
2. Yeh TS, Pollack MM, Ruttimann UE *et al.* Validation of a physiologic stability index for use in critically ill infants and children. *Pediatr Res* 1984; **18**: 445–451.
3. Pollack MM, Ruttimann UE, Getson PR *et al.* Accurate prediction of the outcome of pediatric intensive care. A new quantitative method. *N Engl J Med* 1987; **316**: 134–139.

Key message

Across a broad range of pediatric ICUs, outcomes can be predicted on the basis of physiological parameters measured on admission. Pediatric ICUs can be compared on the basis of their outcomes as measured against these predictions, and the effects of differing approaches to treatment can be measured by adjusting outcomes for severity of illness.

Why it's important

The pediatric intensive care specialist is defined not just by the patients he treats, but also by the environment he maintains. The opportunity to measure one's approaches against standardized outcome predictions enables the specialist to change the ICU and the treatments it offers, while measuring the effects of those changes on outcome.

Strengths

The study and report are statistically elegant. The paper accomplished its goal, and showed that expectations for outcome can be quantified.

Weaknesses

None of significance.

Relevance

We are forever on the horns of a dilemma. We want to be able to measure our progress and define our expectations, but we do not want to be told who will die and who deserves ongoing care. The conflict is vital. It remains to be seen if indices like the PRISM score will be applied appropriately to groups, or if they will be turned around and applied inappropriately as a means to predict individual outcomes.

Table 21-1. Pediatric ICU and patient population characteristics previously reported

ICU	No. of beds (ICU/ hospital)	Children's hospital	No. of patients	Median age (mo)	Medicine patients (%)	Emergency admissions (%)	Significant chronic Disease (%)	Deaths (%)
A ^a	16/224	Y	882/248	33/31	39/50	57/66	29/24	66 (8.0)/ 24 (9.7)
B	12/80	N	262	14.5	54	78	30	14 (5.3)
C	12/96	N	227	19	50	53	48	23 (10.1)
D	6/55	N	104	18	64	79	36	13 (12.5)
E	4/63	N	232	24	41	61	28	20 (8.6)
F	7/114	N	204	24	54	91	27	36 (17.6)
G	10/121	Y	199	36	67	83	22	6 (3.0)
H	9/90	Y	192	36	40	68	24	12 (6.3)
I	8/50	N	152	26	81	87	18	7 (4.6)
Significance		.0001	.0001	.0001	.0001			

Data shown for two time periods: 1980–1982, 1984–1985.

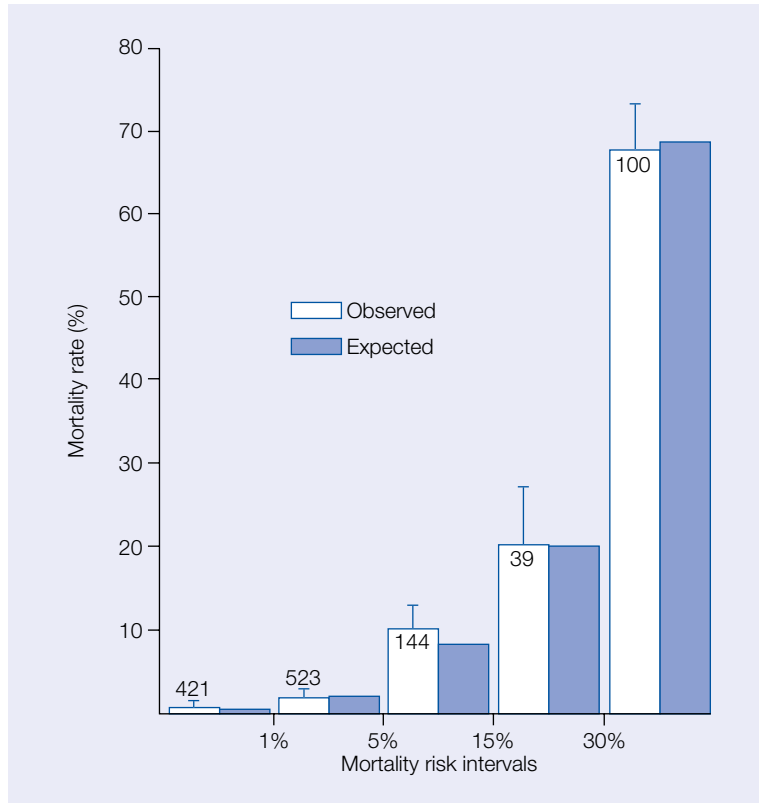

Fig. 21-6. Comparison of the observed and expected (based on the PRISM score) mortality rates in five severity of illness strata from the validation group. The number of patients in each mortality risk group is shown as insets, and the predicted outcomes were not different from the expected outcomes ($\chi^2(5) = 0.80, p > 0.95$)

Recent papers

Michelle Hayes and Neil Soni

Introduction

Intensive care does not stand still, and there have been some impressive papers that have appeared since the first edition of this book. The title “classics” clearly implies a paper that is not only important, but “has stood the test of time.” This new edition has given us the opportunity to select a small group of recent papers that are impressive, have the potential to be pivotal in how we view established practice, may alter practice, and may even become genuine classics with time.

As many aspects of intensive care practice could be described as volatile, and vogues sweep in and out with almost cyclical rhythm, there is inherent risk in selecting recent papers that may become classics. Those selected here are already influencing intensive care thought, and some, if not all, practice, and they probably will stand the test of time.

Rivers and resuscitation are already word association in a remarkably short space of time, and has provided focus in the emergency room. Hypothermia is making a comeback in neurological injury, and TRICC has radically altered transfusion practice. Outreach and medical emergency teams are de rigeur, but the MET study demonstrated that assessing their value is problematic, while the pulmonary catheter still fails to find convincing support from prospective studies. Insulin therapy is being re-examined, and, of course, the SAFE study not only confirmed what we knew, but, far more importantly, demonstrated that big effective trials can be performed in the ICU. A somewhat lower profile paper looks at withdrawal of treatment and starts realistically addressing issues in ICU that have been neglected too long.

We like these papers, and think that in 10 , 20, or even 50 years, they will be seen as milestone papers. We hope you agree.

Title***A multicenter, randomized, controlled clinical trial of transfusion requirements in critical care***

Author

Paul C. Hébert, M.D., George Wells, Ph.D., Morris A. Blajchman, M.D., John Marshall, M.D., Claudio Martin, M.D., Giuseppe Pagliarello, M.D., Martin Tweeddale, M.D., Ph.D., Irwin Schweitzer, M.Sc., Elizabeth Yetisir, M.Sc., for The Transfusion Requirements in Critical Care Investigators for the Canadian Critical Care Trials Group

Reference

N Engl J Med 1999; **340**:6:409–417

Abstract

BACKGROUND: To determine whether a restrictive strategy of red cell transfusion and a liberal strategy produced equivalent results in critically ill patients, we compared the rates of death from all causes at 30 days and the severity of organ dysfunction. **METHODS:** We enrolled 838 critically ill patients with euolemia after initial treatment, who had hemoglobin concentrations of less than 9.0 g per deciliter within 72 hours after admission to the intensive care unit, and randomly assigned 418 patients to a restrictive strategy of transfusion, in which red cells were transfused if the hemoglobin concentration dropped below 7.0 g per deciliter and hemoglobin concentrations were maintained at 7.0 to 9.0 g per deciliter, and 420 patients to a liberal strategy, in which transfusions were given when the hemoglobin concentration fell below 10.0 g per deciliter and hemoglobin concentrations were maintained at 10.0 to 12.0 g per deciliter. **RESULTS:** Overall, 30-day mortality was similar in the two groups (18.7 percent vs. 23.3 percent, $p = 0.11$). However, the rates were significantly lower with the restrictive transfusion strategy among patients who were less acutely ill — those with an Acute Physiology and Chronic Health Evaluation II score of 20 (8.7 percent in the restrictive-strategy group and 16.1 percent in the liberal-strategy group, $p = 0.03$) — and among patients who were less than 55 years of age (5.7 percent and 13.0 percent, respectively; $p = 0.02$), but not among patients with clinically significant cardiac disease (20.5 percent and 22.9 percent, respectively; $p = 0.69$). The mortality rate during hospitalization was significantly lower in the restrictive-strategy group (22.2 percent vs. 28.1 percent, $p = 0.05$). **CONCLUSIONS:** A restrictive strategy of red cell transfusion is at least as effective as, and possibly superior to, a liberal transfusion strategy in critically ill patients, with the possible exception of patients with acute myocardial infarction and unstable angina.

Summary

This study suggested that in the critically ill, the transfusion threshold could be less than the 9–10 g/dl that had been the previous standard of practice. The figure that was suggested was a haemoglobin concentration between 7.0 and 9.0 g/dl. The authors were cautious about those with significant cardiac disease, in particular those with acute myocardial infarction and unstable angina.

Citation count**880**

Related references

1. Carson JL, Hill S, Carless P, Hebert P, Henry D. Transfusion triggers: a systematic review of the literature. *Transfus Med Rev* 2002; **16**(3):187–99.
2. Hill SR, Carless PA, Henry DA, Carson JL, Hebert PC, McClelland DB, et al. Transfusion thresholds and other strategies for guiding allogeneic red blood cell transfusion. *Cochrane Database Syst Rev* 2002(2):CD002042.
3. Walsh TS, Lee RJ, Maciver CR, Garrioch M, Mackirdy F, Binning AR, et al. Anemia during and at discharge from intensive care: the impact of restrictive blood transfusion practice. *Intensive Care Med* 2006; **32**(1):100–9.

Key message

The transfusion threshold in critically ill patients can be between 7–9 g/dl without adverse effects, except in those with ischemic heart disease.

Why it's important

In an era of reducing blood supplies, and anxiety about transfusion, this allows a reduction in the amount of blood transfused. It challenges an unsubstantiated belief that high hemoglobin values are safe, effective, and necessary in the critically ill. It has triggered a more discerning look at the physiology of oxygen transport in the context of hemoglobin availability, and has also raised the question of whether transfusion has problems in its own right, in terms of risk of infection, which appeared to be higher in those transfused. The use of leuko-depleted blood may make the last observation irrelevant in the future.

Strengths

A large, randomized study run in 25 centers over a three year period. Patients in the restrictive group ran with minimum hemoglobin concentration of 7 g/dl, in contrast with the more conventional 10 g/dl in the control group. The average APACHE II score was 21, indicating a reasonably sick population.

The study showed the average hemoglobin in the restrictive group was 8.5 g/dl, and 10.7 g/dl in the liberal group. Thirty-three percent of the restrictive group did not receive any blood, but all of the liberal group received blood, so the transfusion rate was reasonably high, making the findings more impressive. There was an average transfusion requirement difference of over 2 units between the groups. There was a significant difference ($p = 0.05$) in the hospital mortality, with a lower mortality in the restrictive group.

Weaknesses

A total of 838 patients were entered into the study, while, after interim analysis, 1620 patients would have been ideal to satisfy the power analysis. Although the difference in hospital mortality achieved significance, neither intensive care mortality nor the 60 day mortality differences were significant, although the trends were similar.

Approximately a quarter of these patients had cardiac disease with no evidence of problems. The message from the trial was clear.

Relevance

Previously, the critically ill population were perceived to be at risk if anemic, which was considered to be less than 9 g/dl. This definition of relevant anemia has been adjusted downwards toward 7.0 g/dl, resulting in a significant reduction in transfusion requirements in the critically ill. This has been generally accepted, and the question that is now relevant is in which patients caution is advised. We know about those with overt ischemia, but is there a covert group with increased risk factors? The new question is “how low, and in whom?”

Title

Early goal-directed therapy in the treatment of severe sepsis and septic shock

Author

Rivers E, Nguyen B, Havstad S, Ressler J, Muzzin A, Knoblich B, Peterson E, Tomlanovich M

Reference

N Engl J Med 2001; **345**:19: 1368–77

Abstract

BACKGROUND: Goal-directed therapy has been used for severe sepsis and septic shock in the intensive care unit. This approach involves adjustments of cardiac preload, afterload, and contractility to balance oxygen delivery with oxygen demand. The purpose of this study was to evaluate the efficacy of early goal-directed therapy before admission to the intensive care unit. **METHODS:** We randomly assigned patients who arrived at an urban emergency department with severe sepsis or septic shock to receive either six hours of early goal-directed therapy, or standard therapy (as a control), before admission to the intensive care unit. Clinicians who subsequently assumed the care of the patients were blinded to the treatment assignment. In-hospital mortality (the primary efficacy outcome), end points with respect to resuscitation, and Acute Physiology and Chronic Health Evaluation (APACHE II) scores were obtained serially for 72 hours and compared between the study groups. **RESULTS:** Of the 263 enrolled patients, 130 were randomly assigned to early goal-directed therapy and 133 to standard therapy; there were no significant differences between the groups with respect to baseline characteristics. In-hospital mortality was 30.5 percent in the group assigned to early goal-directed therapy, as compared with 46.5 percent in the group assigned to standard therapy ($p = 0.009$). During the interval from 7 to 72 hours, the patients assigned to early goal-directed therapy had a significantly higher mean (\pm SD) central venous oxygen saturation (70.4 \pm 10.7 percent vs. 65.3 \pm 11.4 percent), a lower lactate concentration (3.0 \pm 4.4 vs. 3.9 \pm 4.4 mmol per liter), a lower base deficit (2.0 \pm 6.6 vs. 5.1 \pm 6.7 mmol per liter), and a higher pH (7.40 \pm 0.12 vs. 7.36 \pm 0.12) than the patients assigned to standard therapy ($p < \text{or} = 0.02$ for all comparisons). During the same period, mean APACHE II scores were significantly lower, indicating less severe organ dysfunction in the patients assigned to early goal-directed therapy than in those assigned to standard therapy (13.0 \pm 6.3 vs. 15.9 \pm 6.4, $p < 0.001$). **CONCLUSIONS:** Early goal-directed therapy provides significant benefits with respect to outcome in patients with severe sepsis and septic shock.

Summary

Goal-directed therapy has had a checkered career. In this study, the concept of aggressive management of hemodynamics was applied to patients presenting in casualty with severe sepsis. Relative hypotension, less than 90 mmHg systolic, and a lactate of greater than 4 mmol/l, were part of the criteria for inclusion. After basic resuscitation, patients were randomized to either the early goal-directed therapy or standard treatment groups. The goal-directed therapy was based upon a mean arterial pressure around 65 mmHg, a hematocrit of 30%, and a central venous oxygen saturation of 70%. Fluids, blood, vasodilators, and dobutamine were used to achieve these goals.

Two hundred thirty-six patients were studied, and there were significant differences between standard care and the early goal-directed group. The standard care group had higher heart rate and lower blood pressure, but similar central venous pressure. They also

had lower central venous oxygen saturation and higher lactate. The in-hospital and 28-day mortality was higher in the standard therapy group.

In the initial 6 hours, the goal-directed group had more fluid, more blood transfusions, and more inotropic support, but in the subsequent 72 hours, the standard group had more fluid, blood, and vasopressors. They also had more requirement for ventilation.

Patients treated more aggressively earlier did better. The use of the central venous oxygen saturation was helpful as an endpoint.

Citation count 1100

Related references

1. Hayes MA, Timmins AC, Yau EH, Palazzo M, Hinds CJ, Watson D. Elevation of systemic oxygen delivery in the treatment of critically ill patients. *N Engl J Med* 1994; **330**(24):1717–22.
2. Reinhart K, Bloos F. The value of venous oximetry. *Curr Opin Crit Care* 2005; **11**(3):259–63.
3. Shoemaker WC, Fleming AW. Resuscitation of the trauma patient: restoration of hemodynamic functions using clinical algorithms. *Ann Emerg Med* 1986; **15**(12):1437–44.

Key message

The use of specific targeted end-points in early resuscitation of septic patients improves outcome when compared with the standard resuscitation. Early resuscitation is better than late, in sepsis as in other conditions.

Why it's important

While in trauma it has long been established that early adequate resuscitation is beneficial, that message has not been extrapolated to sepsis. This study implies that standard resuscitation may be inadequate, and that specific endpoints help guide more rigorous intervention. It also highlights the use of continuous central venous saturation as a useful, easily applied technology in the emergency department, and suggests that it provides a functional marker of resuscitation adequacy. The use of lactate is also mentioned.

Strengths

It is a reasonably-sized study with 263 patients, and the criteria for inclusion suggest a sick population. The protocol for early goal-directed therapy is simple, pragmatic, and user-friendly, so it would be easily applied. Central venous oxygen saturation, the cheap and cheerful cousin of mixed venous oxygen saturation, is both simple to use and an effective endpoint. The results suggest that the early application of treatment pays dividends. It makes sense.

Weaknesses

The control group is assumed to be adequately resuscitated, although the blood pressure was lower and the heart rate higher as time progressed. Central venous saturation of 70% was met by two-thirds of those in the standard group, yet there was significant difference in the central venous saturation between the groups. Interestingly, there was a significant difference in base deficit between the groups, but not pH or lactate, at least in the first few hours, although there were differences in both base excess and lactate as time progressed.

It seems clear that the protocol group were better resuscitated than the standard group. Translating this finding to other institutions assumes that either the standard resuscitation is usually poor everywhere, or that no matter how good standard actually is, the protocol will do better. Hence, it leads to the assumption that normal resuscitation (everywhere) is inadequate, therefore, the protocol will do better, and therefore the protocol must be applied. These assumptions may well be invalid in a different context.

Relevance

It demonstrates convincingly that early adequate resuscitation is beneficial when compared to inadequate resuscitation. It defines a role for central venous oxygen saturation measurement as a useful tool in resuscitation in the emergency department. It leads to the assumption that standard resuscitation is often inadequate, and that protocol-driven resuscitation will be better.

Title***Treatment of comatose survivors of out-of-hospital cardiac arrest with induced hypothermia***

Author

Bernard SA, Gray TW, Buist MD, Jones BM, Silvester W, Gutteridge G, Smith K

Reference*N Engl J Med* 2002; **346**:8:557–63

Abstract

BACKGROUND: Cardiac arrest outside the hospital is common and has a poor outcome. Studies in laboratory animals suggest that hypothermia induced shortly after the restoration of spontaneous circulation may improve neurologic outcome, but there have been no conclusive studies in humans. In a randomized, controlled trial, we compared the effects of moderate hypothermia and normothermia in patients who remained unconscious after resuscitation from out-of-hospital cardiac arrest. **METHODS:** The study subjects were 77 patients who were randomly assigned to treatment with hypothermia (with the core body temperature reduced to 33 degrees C within 2 hours after the return of spontaneous circulation, and maintained at that temperature for 12 hours), or normothermia. The primary outcome measure was survival to hospital discharge with sufficiently good neurologic function to be discharged to home, or to a rehabilitation facility. **RESULTS:** The demographic characteristics of the patients were similar in the hypothermia and normothermia groups. Twenty-one of the 43 patients treated with hypothermia (49 percent) survived and had a good outcome; that is, they were discharged home or to a rehabilitation facility, as compared with nine of the 34 treated with normothermia (26 percent, $p = 0.046$). After adjustment for baseline differences in age and time from collapse to the return of spontaneous circulation, the odds ratio for a good outcome with hypothermia as compared with normothermia was 5.25 (95 percent confidence interval, 1.47 to 18.76; $p = 0.011$). Hypothermia was associated with a lower cardiac index, higher systemic vascular resistance, and hyperglycemia. There was no difference in the frequency of adverse events. **CONCLUSIONS:** Our preliminary observations suggest that treatment with moderate hypothermia appears to improve outcomes in patients with coma after resuscitation from out-of-hospital cardiac arrest.

Summary

The use of moderate hypothermia in patients who, post-arrest, have restoration of their circulation but remain comatose has been shown to have beneficial events, with a considerable increase in the likelihood of a good outcome.

Citation count 578

Related references

1. The hypothermia after cardiac arrest study group. Mild therapeutic hypothermia to improve the neurologic outcome after cardiac arrest. *N Engl J Med* 2002; **346**(8):549–56.
2. Bernard SA, Jones BM, Horne MK. Clinical trial of induced hypothermia in comatose survivors of out-of-hospital cardiac arrest. *Ann Emerg Med* 1997; **30**(2):146–53.
3. Popp E, Sterz F, Bottiger BW. Therapeutic hypothermia after cardiac arrest. *Anaesthesist* 2005; **54**(2):96–106.

4. Smith TL, Bleck TP. Hypothermia and neurologic outcome in patients following cardiac arrest: should we be hot to cool off our patients? *Crit Care* 2002; **6**(5):377–80.
5. Safar P. Recent advances in cardiopulmonary-cerebral resuscitation: a review. *Ann Emerg Med* 1984; **13**(9 Pt 2):856–62.

Key message

After restoration of cardiac output following cardiac arrest, but where consciousness has not returned, then hypothermia between 32 and 34 degrees C is beneficial. In the studies, the cooling to 33 degrees C was within 2 hours of the return of spontaneous circulation, so that it is practical to achieve this after the arrest.

Why it's important

Previously, there has been little to indicate that any therapeutic maneuvers were of particular benefit in preventing or ameliorating damage following cardiac arrest. Two studies, this one and the European study (the hypothermia after cardiac arrest study group) both indicate that moderate hypothermia appears to be beneficial. This will undoubtedly change the management of some patients post-arrest. As this involves both thought and technology, implementing this therapy requires some forward planning.

Strengths

An initial study from the Melbourne group (see references) kick-started this train of thought, which has come and gone over the last 20 years, with some promising results. The current study enrolled 43 patients in the hypothermia group. The European study, in the same issue, had 137 patients allocated. The presence of two very similar studies at opposite ends of the world must add weight to the findings. Importantly, in both studies, the quality of the outcome was considered, and a good outcome in the Australian study was discharge to rehabilitation or to home.

Another important report in the study was that age influenced outcome, as did the time to the return of spontaneous circulation. This provides additional guidance in the implementation of this therapy.

Weaknesses

The size of the studies are a potential weakness, although such studies are incredibly difficult to perform, and both groups should be congratulated on a phenomenal achievement. The period of time that hypothermia was maintained was 12 hours, but it may have been 2 hours from the return of the circulation before it was initiated. This suggests a major therapeutic benefit from a relatively short period of hypothermia. This time period is different from the 24 hours in the European study. In neither study was it possible to blind the clinicians, so bias is possible, but the results are almost too impressive for that to be a serious consideration.

Relevance

For most critical care facilities, this will change practice, and the evidence from these studies is already incorporated into guidelines and should become part of routine practice. The situations where this therapy is indicated are quite specific, and the temptation to roll it out across a whole range of disparate conditions should be resisted. Brain injury is one of the most frustrating aspects of critical care, with a long track record of innovative treatments initially promising, but failing the test of time. It looks like we have a useful treatment, but it would be wise to accrue ongoing data as these maneuvers are implemented.

Title

A randomised controlled trial of the use of pulmonary artery catheters in high-risk surgical patients

Author

Sandham JD, Hull RD, Brant RF, Knox L, Pineo GF, Doig CJ, Laporta DP, Viner S, Passerini L, Devitt H, Kirby A, Jacka M, for the Canadian Critical Care Clinical Trials Group

Reference

N Engl J Med 2003; **348**: 5–14

Abstract

BACKGROUND: Some observational studies suggest that the use of pulmonary artery catheters to guide therapy is associated with increased mortality. **METHODS:** We performed a randomized trial comparing goal-directed therapy guided by a pulmonary artery catheter with standard care without the use of a pulmonary artery catheter. The subjects were high-risk patients 60 years of age or older, with American Society of Anesthesiologists (ASA) class III or IV risk, who were scheduled for urgent or elective major surgery, followed by a stay in an intensive care unit. Outcomes were adjudicated by observers who were unaware of the treatment-group assignments. The primary outcome was in-hospital mortality from any cause. **RESULTS:** Of 3803 eligible patients, 1994 (52.4 percent) underwent randomization. The baseline characteristics of the two treatment groups were similar. A total of 77 of 997 patients who underwent surgery without the use of a pulmonary artery catheter (7.7 percent) died in the hospital, as compared with 78 of 997 patients in whom a pulmonary artery catheter was used (7.8 percent), a difference of 0.1 percent (95 percent confidence interval, -2.3 to 2.5). There was a higher rate of pulmonary embolism in the catheter group than in the standard-care group (8 events vs. 0 events, $p = 0.004$). The survival rates at 6 months among patients in the standard-care and catheter groups were 88.1 and 87.4 percent, respectively (difference, -0.7 percent [95 percent confidence interval, -3.6 to 2.2]; negative survival differences favor standard care); at 12 months, the rates were 83.9 and 83.0 percent, respectively (difference, -0.9 percent [95 percent confidence interval, -4.3 to 2.4]). The median hospital stay was 10 days in each group. **CONCLUSIONS:** We found no benefit to therapy directed by pulmonary artery catheter over standard care in elderly, high-risk surgical patients requiring intensive care. Copyright 2003 Massachusetts Medical Society

Summary

In this study, eligible patients were 60 years of age or older, with ASA class III or IV risk, and were scheduled for urgent or elective major abdominal, thoracic, vascular, or hip fracture surgery.

Three thousand eight hundred and three patients were screened, and 1994 underwent randomization in just over nine years. Nine hundred ninety seven patients were randomized to the pulmonary artery catheter group and 997 to the standard-care group. Cross-over of patients was not permitted. The sample size of 1000 per group was chosen to provide the study with power exceeding 90% for distinguishing between mortality rates of 10% and 15% in the 2 groups, allowing a two-side type 1 error of 5%.

Patients in the standard care group were treated without the use of a pulmonary artery catheter, and measurement of central venous pressure was allowed. Patients in

the catheter group had a pulmonary catheter placed before surgery, and treatment was goal directed.

Goals were an oxygen delivery of 550 to 600 mls/min/m², a cardiac index of 3.5 to 4.5 L/min/m², a mean arterial pressure of 70mmHg, a pulmonary artery occlusion pressure of 18mmHg, a heart rate of less than 120 beats per minute, and a hematocrit of more than 27%. Goals were achieved by fluid loading, inotropic therapy, vasodilator therapy, vasopressors for hypotension, and blood transfusion for a hematocrit of less than 27%. All patients were followed until hospital discharge.

Analysis of results was on an intention-to-treat basis. The primary outcome was in hospital mortality from any cause. Secondary outcomes were 6 month mortality, 12 month mortality, and in-hospital morbidity.

The median hospital stay was the same in both groups, and there was no difference in in-hospital, 6 month, or 12 month mortality.

As far as complications were concerned, there was a higher rate of pulmonary embolism in the pulmonary artery catheter group than in the standard care group (8 events versus 0 events, $p = 0.004$).

In the pulmonary artery catheter group, the goals for cardiac index and oxygen delivery were met in 18.6% and 21% of patients, respectively, at the time of entry, and in 79% and 62.9% of patients, respectively, after surgery. Central venous pressure did not differ significantly between the patients in the pulmonary artery or standard care group.

In conclusion, there was no benefit of treatment guided by pulmonary artery catheter in this large group of patients. Importantly, however, there was no excess mortality as a result of this intervention.

Citation count 252

Related references

1. Connors AF et al: The effectiveness of right heart catheterization in the initial care of critically ill patients. *JAMA* 1996; **276**:889–897.
2. Pulmonary Artery Consensus Conference Participants. Pulmonary Artery Consensus Conference: Consensus Statement. *Crit Care Med* 1997; **25**:910–925.
3. Harvey S, Harrison DA, Singer M, et al. Assessment of the clinical effectiveness of pulmonary artery catheters in management of patients in intensive care (PAC- Man): a randomised controlled trial. *Lancet* 2005; **366**; 472–477.

Key message

No benefit in using pulmonary artery catheter to guide therapy in a group of elderly low-risk surgical patients. The use of the pulmonary artery catheter did not cause an excess mortality.

Why it's important

There is a lot of controversy surrounding the use of pulmonary artery catheters, and it is important to know if there is an excess mortality associated with its use. The pulmonary catheter is expensive to use, and the data obtained is often misinterpreted. It may be more appropriate to use non-invasive monitors which provide similar information.

Strengths

Large, multi-center, randomized, single-blind clinical trial. Ten year commitment. Analyzed by intention to treat. Cross-overs were not permitted.

Weaknesses

Questionable selection of patients, in that they were very low-risk. Overall mortality rate was low. Treatment group did not always achieve set goals. The use of supra-physiological goals in the treatment group was inappropriate for all comers, in that more than 50% of patients were undergoing major vascular surgery.

Relevance

This study convincingly rejects the benefit of supra-physiological goal-directed therapy in this population of patients; moreover, there appears to be little evidence to support the intra-operative use of the pulmonary artery catheter. The results, however, cannot be applied to other groups of critically ill patients. There is also increasing availability of non-invasive monitoring technology, which may be more appropriate for use in high-risk surgical and critically ill patients.

Title

Most critically ill patients are perceived to die in comfort during withdrawal of life support: a Canadian multicentre study

Author

Rocker GM, Heyland DK, Cook DJ, Dodek PM, Kutsogiannis DJ, O'Callaghan CJ

Reference

Can J Anaesth 2004; **51**;6:623–30

Abstract

PURPOSE: Most deaths in intensive care units (ICUs) follow a withdrawal of life support (LS). Evaluation of this process, including the related perspectives of grieving family members, is integral to improvement of palliation in the ICU. **METHODS:** A prospective, multicenter, cohort study in six Canadian university-affiliated ICUs included 206 ICU patients (length of stay > or = 48 hr) who received mechanical ventilation (MV) before LS withdrawal. We recorded modes, sequence, and time course of LS withdrawal, and drug usage (4 hr before; 4–8 hr and 8–12 hr before death). We asked a specified family member to assess patient comfort and key aspects of end-of-life care. **RESULTS:** MV was withdrawn from 155/206 (75.2%) patients; 97/155 (62.6%) died after extubation, and 58/155 (37.4%) died with an airway in place. The most frequently used drugs and the cumulative doses [median (range)] in the four hours before death: morphine 119/206, 24 mg, (2–450 mg); midazolam 45/206, 24 mg, (2–380 mg); and lorazepam 35/206, 4 mg, (1–80 mg). These doses did not differ among the three time periods before death. Of 196 responses from family members, most indicated that patients were perceived to be either totally (73, 37.2%), very (48, 24.5%), or mostly comfortable (58, 29.6%). Times to death, morphine use, and family members' perceptions of comfort were similar for each type of change to MV. **CONCLUSIONS:** Most patients were perceived by family members to die in comfort during a withdrawal of LS. Perceptions of patient comfort and drug use in the hours before death were not associated with the mode or sequence of withdrawal of LS, or the time to death.

Summary

While this was a realistic attempt to evaluate the efficacy of treating discomfort in dying patients, it was also an explicit description of some of the techniques involved in withdrawing life support. The study determined that the family perception of the patient's comfort prior to death was not usually associated with the mode of withdrawal. In doing so, the study describes the withdrawal of ventilation, many with extubation, and also discusses simultaneous withdrawal of several life support modalities. The paper provides a detailed description of the medications used to provide comfort, and the range of dosages that have been employed.

Citation count

3

Related references

1. Chan JD, Treece PD, Engelberg RA, Crowley L, Rubenfeld GD, Steinberg KP, et al. Narcotic and benzodiazepine use after withdrawal of life support: association with time to death? *Chest* 2004; **126**(1):286–93.

2. Asch DA, Faber-Langendoen K, Shea JA, Christakis NA. The sequence of withdrawing life-sustaining treatment from patients. *Am J Med* 1999; **107**(2):153–6.

Key message

That comfort in dying is important, and that in order to evaluate the efficacy of current practice, there is clear need to determine what constitutes current practice.

Why it's important

Withdrawal of life support is an integral part of critical care practice, and in many units is a relatively common mode of death. Despite this ordinary observation, there is a paucity of pragmatic information about the modes of withdrawal in common practice, and less about the management of comfort. There is a plethora of papers discussing the deeper ethical and philosophical dimensions of these issues, and no shortage of sage advice about decision-making process. This paper is different, as it is pragmatic and documents practice. It has, with several other similar papers, opened up the potential for discussion of an important everyday dilemma that has hitherto been somewhat covert.

Strengths

The survey is spread over several hospitals across Canada, and represents a broad view of practice. The respondent rate was high at 95%, and suggests a willingness to be involved in a very important aspect of daily work. The design of the study ties together the management of withdrawal with patient comfort, and it embraces the importance of the family's perception of patient comfort.

Weaknesses

It is observational, but given the lack of information in this area, that is a minor weakness. The measurement systems for such subjective matters as family perception are far from robust, and it was an open study, which may have influenced behavior.

Relevance

Palliation is an important aspect of intensive care practice that has been neglected. A good starting point would be more discussion of practical detail. Given the growing legal interest in this area of practice, more open exchange of information and research into the efficacy of our palliative care is long overdue.

Title***A comparison of albumin and saline for fluid resuscitation in the intensive care unit***

Author

Finfer S, Bellomo R, Boyce N, French J, Myburgh J, Norton R

Reference*N Engl J Med* 2004;350;22;2247–56

Abstract

BACKGROUND: It remains uncertain whether the choice of resuscitation fluid for patients in intensive care units (ICUs) affects survival. We conducted a multi-center, randomized, double-blind trial to compare the effect of fluid resuscitation with albumin or saline on mortality in a heterogeneous population of patients in the ICU. METHODS: We randomly assigned patients who had been admitted to the ICU to receive either 4 percent albumin or normal saline for intravascular fluid resuscitation during the next 28 days. The primary outcome measure was death from any cause during the 28-day period after randomization. RESULTS: Of the 6997 patients who underwent randomization, 3497 were assigned to receive albumin and 3500 to receive saline; the two groups had similar baseline characteristics. There were 726 deaths in the albumin group, as compared with 729 deaths in the saline group (relative risk of death, 0.99; 95 percent confidence interval, 0.91 to 1.09; $p = 0.87$). The proportion of patients with new single-organ and multiple-organ failure was similar in the two groups ($p = 0.85$). There were no significant differences between the groups in the mean (\pm SD) numbers of days spent in the ICU (6.5 \pm 6.6 in the albumin group, and 6.2 \pm 6.2 in the saline group, $p = 0.44$), days spent in the hospital (15.3 \pm 9.6 and 15.6 \pm 9.6, respectively; $p = 0.30$), days of mechanical ventilation (4.5 \pm 6.1 and 4.3 \pm 5.7, respectively; $p = 0.74$), or days of renal-replacement therapy (0.5 \pm 2.3 and 0.4 \pm 2.0, respectively; $p=0.41$). CONCLUSIONS: In patients in the ICU, use of either 4 percent albumin or normal saline for fluid resuscitation results in similar outcomes at 28 days.

Summary

Following the publication of the Cochrane Collaboration review of the use of albumin in the critically ill, there was considerable controversy over its use, as it appeared to be associated with a higher mortality than other fluids. This multi-center study was powered to answer the simple question raised by the Cochrane Collaboration of whether there were adverse effects associated with albumin administration. The conclusions of the Cochrane Collaboration were already in doubt from the conflicting findings from a separate meta-analysis analyzing similar, although not identical, data. It was in the context of the unassailable 'reliability' of meta-analysis and systematic review as the gold standard for evidence that an adequately powered, randomized, controlled trial was designed. The size of this randomized controlled trial was approximately four times greater than that of the meta-analysis. It compared albumin with saline, and found no difference in the 28 day mortality.

Citation count

235

Related references

1. Human albumin administration in critically ill patients: systematic review of randomised controlled trials. Cochrane Injuries Group Albumin Reviewers. *BMJ* 1998; **317**(7153): 235–40.
2. Choi PT, Yip G, Quinonez LG, Cook DJ. Crystalloids vs. colloids in fluid resuscitation: a systematic review. *Crit Care Med* 1999; **27**(1):200-10.
3. Wilkes MM, Navickis RJ. Patient survival after human albumin administration. A meta-analysis of randomized, controlled trials. *Ann Intern Med* 2001; **135**(3):149–64.

Key message

The use of albumin in the critically ill is not associated with a higher mortality than saline.

Why it's important

This is a key paper, as it addressed several issues. It provided genuine evidence about the safety of albumin in the critically ill. In doing so, it clearly demonstrated the weaknesses and flaws in meta-analysis and systematic review as a gold standard, and served to emphasize the risks of accepting available but inadequate evidence as being equivalent to substantive evidence. It also showed the power of collaborative working for critical care research.

Strengths

A large, adequately-powered study with robust methodology being uniformly administered over many sites. Clear definition of a single question, in a reasonably defined population, and with clear outcome measures. A reasonably consistent standard of intensive care practice in the units involved.

Weaknesses

The use of saline as the alternative fluid. Saline may not be the ideal resuscitative fluid, given possible issues with acidosis. As in any study of the critically ill, there is massive heterogeneity of population, of interventions, and of the critical care practice, although this was probably less in the Australasian environment than elsewhere.

Relevance

The albumin story can move on to more relevant areas, such as determining where specific indications for albumin may lie. The authority of meta-analysis has been challenged and found to be wanting. Possibly the most important relevance is the clear demonstration of the power of collaborative study.

Title

Introduction of the medical emergency team (MET) system: a cluster-randomized controlled trial

Author

Hillman K, Chen J, Cretikos M, Bellomo R, Brown D, Doig G, Finfer S, Flabouris A

Reference

Lancet 2005; **365**:9477:2091–7

Abstract

BACKGROUND: Patients with cardiac arrests or who die in general wards have often received delayed or inadequate care. We investigated whether the medical emergency team (MET) system could reduce the incidence of cardiac arrests, unplanned admissions to intensive care units (ICU), and deaths. **METHODS:** We randomized 23 hospitals in Australia to continue functioning as usual (n=11) or to introduce a MET system (n=12). The primary outcome was the composite of cardiac arrest, unexpected death, or unplanned ICU admission during the 6-month study period after MET activation. Analysis was by intention-to-treat. **FINDINGS:** Introduction of the MET increased the overall calling incidence for an emergency team (3.1 vs. 8.7 per 1000 admissions, p = 0.0001). The MET was called to 30% of patients who fulfilled the calling criteria and who were subsequently admitted to the ICU. During the study, we recorded similar incidence of the composite primary outcome in the control and MET hospitals (5.86 vs. 5.31 per 1000 admissions, p = 0.640), as well as of the individual secondary outcomes (cardiac arrests, 1.64 vs. 1.31, p = 0.736; unplanned ICU admissions, 4.68 vs. 4.19, p = 0.599; and unexpected deaths, 1.18 vs. 1.06, p = 0.752). A reduction in the rate of cardiac arrests (p = 0.003) and unexpected deaths (p = 0.01) was seen from baseline to the study period for both groups combined. **INTERPRETATION:** The MET system greatly increases emergency team calling, but does not substantially affect the incidence of cardiac arrest, unplanned ICU admissions, or unexpected death.

Summary

The study sought to determine whether the introduction of a medical emergency team resulted in overt benefit. They used a composite of cardiac arrest, unexpected death, or unplanned ITU admission as the primary endpoint. While they found no benefit in terms of the primary endpoint, the presence of a MET resulted in far more frequent calls to medical events that were not associated with either cardiac arrest or unexpected death than was the case previously.

Citation count 102

Related references

1. Buist MD, Moore GE, Bernard SA, Waxman BP, Anderson JN, Nguyen TV. Effects of a medical emergency team on reduction of incidence of and mortality from unexpected cardiac arrests in hospital: preliminary study. *Bmj* 2002; **324**(7334):387–90.
2. Kenward G, Castle N, Hodgetts T, Shaikh L. Evaluation of a medical emergency team one year after implementation. *Resuscitation* 2004; **61**(3):257–63.

3. Subbe CP, Davies RG, Williams E, Rutherford P, Gemmell L. Effect of introducing the Modified Early Warning score on clinical outcomes, cardio-pulmonary arrests and intensive care utilisation in acute medical admissions. *Anaesthesia* 2003; **58**(8):797–802.
4. Parr MJ, Hadfield JH, Flabouris A, Bishop G, Hillman K. The Medical Emergency Team: 12 month analysis of reasons for activation, immediate outcome and not-for-resuscitation orders. *Resuscitation* 2001; **50**(1):39–44.
5. Moller JT, Sennild I, Johannessen NW, Jensen PF, Espersen K, Gravenstein JS, et al. Perioperative monitoring with pulse oximetry and late postoperative cognitive dysfunction. *Br J Anaesth* 1993; **71**(3):340–7.

Key message

Intuitively, medical emergency teams should be useful and effective. Once a hospital has had one, it is hard, if not impossible, to disband it. One assumes they achieve something that becomes indispensable. Despite this observation, demonstrating effectiveness is very difficult. The endpoints measured are of low incidence and may not represent the workload of the team, so that it might be akin to measuring an iceberg by evaluating what is showing on the surface. The apparently negative result should focus efforts on describing endpoints that better represent the work of the team.

Why it's important

This was a large, well-thought-through and carefully designed multi-center study trying to address the efficacy of a team that provides education and support, as well as crisis-based medical management across acute services. In many parts of the world, the necessity for such 'safety net' capability is increasingly obvious, yet in an 'evidence' driven environment, providing proof of effect is essential. That proof is elusive. The result was negative. As in so many aspects of intensive care practice, a negative result is seen as indicating that the tested intervention failed. This study, in a particularly difficult assessment area, suggests the likelihood that the study failed because method and measurement are not tuned to evaluate 'system function', i.e. the endpoints are inadequate to achieve a result. If so, then the next step is not dismantling teams, but designing the study that will show what the teams actually achieve.

Strengths

It was an ambitious project addressing a difficult subject. The efficacy of a team in terms of system function, education, and bedside clinical input is a qualitative assessment, but the endpoints of necessity are quantitative. It involved many centers and thousands of potential patients. It had well-defined endpoints. It produced clear results, but of only one aspect of performance. It answered the question of whether the team influences the incidence of major events, and the answer is clearly 'not significantly'.

Weaknesses

The question that was answered may have been the wrong question if the result is used to judge team efficacy.

It was a well-publicized project that by its nature would be likely to emphasize short-falls in care between local hospitals. The control group might therefore feel vulnerable. Indeed, both groups improved the adverse outcome rate. Given the wide range of activities of an MET, the endpoints were very narrow. It has similarities with studies in pulse oximetry where the efficacy of the device is poorly demonstrated by its adverse event rate except in very specific populations (see Moller).

The biggest weakness is that the conclusion, while absolutely correct in terms of the endpoints, may be misleading if taken to represent a true picture of efficacy.

Relevance

Outreach and medical emergency teams are a growth area in critical care. In many hospitals, they fulfill many different functions. This study is the first well-planned and well-executed attempt to define their efficacy. As it was negative, it provides an imperative to further work to establish whether these teams are useful or not. In a broader sense, it raises the question whether the failure of many ITU studies to demonstrate an effect is a true negative finding, or a failure to use sensitive endpoints that are a direct result of the tested intervention.

Title

Intensive insulin therapy in the medical ICU

Author

Van Den Berghe G, Wilmer A, Hermans G, Meersseman W, Wouters PJ, Milants I, Van Wijngaerden E, Bobbaers H, Bouillon R

Reference

N Engl J Med 2006; **354**: 449–461

Abstract

BACKGROUND: Intensive insulin therapy reduces morbidity and mortality in patients in surgical intensive care units (ICUs), but its role in patients in medical ICUs is unknown. **METHODS:** In a prospective, randomized, controlled study of adult patients admitted to our medical ICU, we studied patients who were considered to need intensive care for at least three days. On admission, patients were randomly assigned to strict normalization of blood glucose levels (80 to 110 mg per deciliter [4.4 to 6.1 mmol per liter]) with the use of insulin infusion, or to conventional therapy (insulin administered when the blood glucose level exceeded 215 mg per deciliter [12 mmol per liter], with the infusion tapered when the level fell below 180 mg per deciliter [10 mmol per liter]). There was a history of diabetes in 16.9 percent of the patients. **RESULTS:** In the intention-to-treat analysis of 1200 patients, intensive insulin therapy reduced blood glucose levels but did not significantly reduce in-hospital mortality (40.0 percent in the conventional-treatment group vs. 37.3 percent in the intensive-treatment group, $p = 0.33$). However, morbidity was significantly reduced by the prevention of newly acquired kidney injury, accelerated weaning from mechanical ventilation, and accelerated discharge from the ICU and the hospital. Although length of stay in the ICU could not be predicted on admission, among 433 patients who stayed in the ICU for less than three days, mortality was greater among those receiving intensive insulin therapy. In contrast, among 767 patients who stayed in the ICU for three or more days, in-hospital mortality in the 386 who received intensive insulin therapy was reduced from 52.5 to 43.0 percent ($p = 0.009$), and morbidity was also reduced. **CONCLUSIONS:** Intensive insulin therapy significantly reduced morbidity but not mortality among all patients in the medical ICU. Although the risk of subsequent death and disease was reduced in patients treated for three or more days, these patients could not be identified before therapy. Further studies are needed to confirm these preliminary data. (ClinicalTrials.gov number, NCT00115479.) Copyright 2006 Massachusetts Medical Society.

Summary

This study was performed to address the question of whether intensive insulin therapy could improve outcome in patients in a medical intensive care unit setting. It follows on from a study by the same principal author published in 2001, which demonstrated that tight glycemic control carried out in a surgical ICU facility led not only to reduced infection, organ failure, and critical illness polyneuropathy, but also reduced ICU and hospital mortality. The more recent study was carried out in a single center, and involved the inclusion of 1200 patients admitted to a medical intensive care unit. This was a prospective, randomized, controlled study of adult patients thought to need at least three days of ICU care. On admission, patients were randomized to strict normalization of blood glucose levels with the use of an insulin infusion (4.4–6.1 mmol/l), or to conventional treatment, in which insulin was commenced when the blood glucose exceeded 12 mmol/l and was tapered off when the level fell below 10 mmol/l.

When the results were analyzed on an intention-to-treat basis, ICU and hospital mortality were not significantly reduced by tight glycemic control. Morbidity, however, was reduced in the intensive treatment group on the basis of reduction in newly acquired kidney injury, time to wean from the ventilator, and time to ICU and hospital discharge. Interestingly, in contrast to the previous study, there was no difference between the groups of incidence of bacteremia or prolonged requirement for antibiotics.

Subgroup analysis demonstrated that the mortality rate was elevated for patients who stayed in the intensive care unit for less than 3 days and received the intensive insulin therapy, compared to those who received conventional treatment. This may be due to the fact there was a higher proportion of patients in the intensive treatment group for whom intensive care was limited or withdrawn due to reasons of futility within the first 72 hours after admission. Given this, it is therefore unsurprising that there was an improvement in outcome for those in the intensive treatment group who remained for more than 3 days. The authors suggested that benefit from intensive insulin therapy requires time to be realized. It is important to note that in excess of half the patients received corticosteroids.

There was some concern that there were greater incidences of hypoglycemia in the medical ICU patients when compared to the previous study of surgical patients. This may be due to the differing feeding regimens used in both studies. Hypoglycemia was identified as an independent risk factor for death, and it was therefore suggested that the hypoglycemia induced by intensive insulin treatment may have reduced some of the potential benefit of this treatment modality.

Citation count 284

Related references

1. Van den Berghe G, Wouters P, Weekers F et al. Intensive Insulin Therapy in the Surgical Intensive Care Unit. *N Engl J Med* 2001; **345**: 1359–1367.
2. Malmberg K. Prospective randomised study of intensive insulin treatment on long term survival after acute myocardial infarction in patients with diabetes mellitus. *BMJ* 1997; **314**: 1512–1515.
3. Hawthorne G, Irgens LM, Lie RT. Outcome of pregnancy in diabetic women in North-East England and Norway, 1994–1997. *BMJ* 2000; **321**:730–731.
4. Runkhorst FM, Kuhnt E, Engel C, et al. Intensive insulin therapy in patients with severe sepsis and septic shock is associated with an increased incidence of hypoglycaemia—results from a randomised multi-centre study. *Infection* 2005; **33**: 19–20.
5. Mehta SR, Yusuf S, Diaz R, et al. Effect of glucose-insulin-potassium infusion on mortality in patients with acute ST-segment elevation myocardial infarction: the CREATE ECLA randomised controlled trial. *JAMA* 2005; **293**: 437–446.

Key message

The use of tight glycemic control in a medical intensive care population led to reduction in newly acquired kidney injury, time to wean from the ventilator, and time to ICU and hospital discharge. There was, however, no reduction in mortality.

Why it's important

Improving morbidity is of utmost importance because it reduces time in both the ICU and hospital.

Strengths

Large, prospective, randomized, controlled study with clear treatment protocol.

Weaknesses

Single-center study, unblinded. Probably underpowered to be able to show a significant effect on mortality. The significant reduction in mortality in patients who stayed in the unit for more than 3 days was as a result of a post hoc subgroup analysis.

Among the 433 patients who stayed in the ICU for less than 3 days, 56 in the intensive treatment group and 42 in the conventional treatment group died, the statistical significance of this varied depending on the analytical test. P values were not adjusted for multiple comparisons.

Results may not translate to a busy ICU, in relation to maintenance of tight glycemic control and avoidance of hypoglycemia.

Relevance

Although in this study there was no clear reduction in mortality, there did appear to be a beneficial effect of tight glycemic control on morbidity. There was, however, concern at the high incidence of hypoglycemia, which was 3.7 times that which occurred in the original study. Further work is required to demonstrate a beneficial overall effect in the medical ICU population.

Frequently cited papers in critical care

Table of papers on critical care, arranged by number of citations they received

The citation frequency of these papers was calculated by identifying relevant papers on the Science Citation Index™ (Web of Science™). The references, including the number of citations they received, were downloaded into Reference Manager™; the resulting list of references was converted into an Excel spreadsheet, and the references were arranged by number of citations.

The search to identify papers for inclusion in this list was quite narrow, and only identified papers that mentioned 'critical care', 'intensive care', or 'critically ill' in the title. Some 8800 papers were found, published between 1980 and 2002.

Some 3440 papers had not been cited at all (not only because they were very recent papers); 535 papers were cited more than 40 times (table).

The number of citations could have been weighted (e.g. number of citations per year) and the references rearranged, but that would perhaps have taken the point of this little study (identifying some highly cited papers in the field of Intensive Care) too far, and attached too much value to the citation frequency as an indicator of the importance, or even quality, of a paper.

Reinhard Wentz (December 2002)

KNAUS WA, WAGNER DP, DRAPER EA, ZIMMERMAN JE, BERGNER M, BASTOS PG <i>et al.</i> THE APACHE-III PROGNOSTIC SYSTEM - RISK PREDICTION OF HOSPITAL MORTALITY FOR CRITICALLY ILL HOSPITALIZED ADULTS. <i>Chest</i> 1991; 100 :1619-36.	873
KNAUS WA, DRAPER EA, WAGNER DP, ZIMMERMAN JE. AN EVALUATION OF OUTCOME FROM INTENSIVE CARE IN MAJOR MEDICAL CENTERS. <i>Annals of Internal Medicine</i> 1986; 104 :410-8.	591
CONNORS AF, SPEROFF T, DAWSON NV, THOMAS C, HARRELL FE, WAGNER D <i>et al.</i> THE EFFECTIVENESS OF RIGHT HEART CATHETERIZATION IN THE INITIAL CARE OF CRITICALLY ILL PATIENTS. <i>Journal of the American Medical Association</i> 1996; 276 :889-97.	466
GUTIERREZ G, PALIZAS F, DOGLIO G, WAINSTEIN N, GALLESIO A, PACIN J <i>et al.</i> GASTRIC INTRAMUCOSAL PH AS A THERAPEUTIC INDEX OF TISSUE OXYGENATION IN CRITICALLY ILL PATIENTS. <i>Lancet</i> 1992; 339 :195-9.	432
STAUFFER JL, OLSON DE, PETTY TL. COMPLICATIONS AND CONSEQUENCES OF ENDOTRACHEAL INTUBATION AND TRACHEOTOMY - A PROSPECTIVE-STUDY OF 150 CRITICALLY ILL ADULT PATIENTS. <i>American Journal of Medicine</i> 1981; 70 :65-76.	416
BIHARI D, SMITHIES M, GIMSON A, TINKER J. THE EFFECTS OF VASODILATION WITH PROSTACYCLIN ON OXYGEN DELIVERY AND UPTAKE IN CRITICALLY ILL PATIENTS. <i>New England Journal of Medicine</i> 1987; 317 :397-403.	351
BOYLE MH, TORRANCE GW, SINCLAIR JC, HORWOOD SP. ECONOMIC-EVALUATION OF NEONATAL INTENSIVE CARE OF VERY-LOW- BIRTH-WEIGHT INFANTS. <i>New England Journal of Medicine</i> 1983; 308 :1330-7.	294
GATTINONI L, BRAZZI L, PELOSI P, LATINI R, TOGNONI G, PESENTI A <i>et al.</i> A TRIAL OF GOAL-ORIENTED HEMODYNAMIC THERAPY IN CRITICALLY ILL PATIENTS. <i>New England Journal of Medicine</i> 1995; 333 :1025-32.	280
DOGLIO GR, PUSAJO JF, EGURROLA MA, BONFIGLI GC, PARRA C, VETERE L <i>et al.</i> GASTRIC MUCOSAL PH AS A PROGNOSTIC INDEX OF MORTALITY IN CRITICALLY ILL PATIENTS. <i>Critical Care Medicine</i> 1991; 19 :1037-40.	266

PITTE D, TARARA D, WENZEL RP. NOSOCOMIAL BLOODSTREAM INFECTION IN CRITICALLY ILL PATIENTS - EXCESS LENGTH OF STAY, EXTRA COSTS, AND ATTRIBUTABLE MORTALITY. <i>Journal of the American Medical Association</i> 1994; 271 :1598-601.	235
LEMESHOW S, TERES D, KLAR J, AVRUNIN JS, GEHLBACH SH, RAPOPORT J. MORTALITY PROBABILITY MODELS (MPM-II) BASED ON AN INTERNATIONAL COHORT OF INTENSIVE CARE UNIT PATIENTS. <i>Journal of the American Medical Association</i> 1993; 270 :2478-86.	234
TAKALA J, KEINANEN O, VAISANEN P, KARI A. MEASUREMENT OF GAS-EXCHANGE IN INTENSIVE CARE - LABORATORY AND CLINICAL VALIDATION OF A NEW DEVICE. <i>Critical Care Medicine</i> 1989; 17 :1041-7.	232
MARANO MA, FONG Y, MOLDAWER LL, WEI H, CALVANO SE, TRACEY KJ <i>et al</i> . SERUM CACHECTIN TUMOR NECROSIS FACTOR IN CRITICALLY ILL PATIENTS WITH BURNS CORRELATES WITH INFECTION AND MORTALITY. <i>Surgery Gynecology & Obstetrics</i> 1990; 170 :32-8.	228
SEGREDO V, CALDWELL JE, MATTHAY MA, SHARMA ML, GRUENKE LD, MILLER RD. PERSISTENT PARALYSIS IN CRITICALLY ILL PATIENTS AFTER LONG-TERM ADMINISTRATION OF VECURONIUM. <i>New England Journal of Medicine</i> 1992; 327 :524-8.	227
ALBERT RK, CONDIE F. HAND WASHING PATTERNS IN MEDICAL INTENSIVE CARE UNITS. <i>New England Journal of Medicine</i> 1981; 304 :1465-6.	227
LEDINGHAM IM, EASTAWAY AT, MCKAY IC, ALCOCK SR, MCDONALD JC, RAMSAY G. TRIPLE REGIMEN OF SELECTIVE DECONTAMINATION OF THE DIGESTIVE TRACT, SYSTEMIC CEFOTAXIME, AND MICROBIOLOGICAL SURVEILLANCE FOR PREVENTION OF ACQUIRED INFECTION IN INTENSIVE CARE. <i>Lancet</i> 1988; 1 :785-90.	226
DEBETS JMH, KAMPMEIJER R, VANDERLINDEN MPMH, BUURMAN WA, VANDERLINDEN CJ. PLASMA TUMOR NECROSIS FACTOR AND MORTALITY IN CRITICALLY ILL SEPTIC PATIENTS. <i>Critical Care Medicine</i> 1989; 17 :489-94.	222
HEBERT PC, WELLS G, BLAJCHMAN MA, MARSHALL J, MARTIN C, PAGLIARELLO G <i>et al</i> . A MULTI-CENTER, RANDOMIZED, CONTROLLED CLINICAL TRIAL OF TRANSFUSION REQUIREMENTS IN CRITICAL CARE. <i>New England Journal of Medicine</i> 1999; 340 :409-17.	221
ZINNER MJ, ZUIDEMA GD, SMITH PL, MIGNOSA M. THE PREVENTION OF UPPER GASTROINTESTINALTRACT BLEEDING IN PATIENTS IN AN INTENSIVE CARE UNIT. <i>Surgery Gynecology & Obstetrics</i> 1981; 153 :214-20.	197
HOOK EW, HORTON CA, SCHABERG DR. FAILURE OF INTENSIVE CARE UNIT SUPPORT TO INFLUENCE MORTALITY FROM PNEUMOCOCCAL BACTEREMIA. <i>Journal of the American Medical Association</i> 1983; 249 :1055-7.	193
LEDINGHAM IM, WATT I. INFLUENCE OF SEDATION ON MORTALITY IN CRITICALLY ILL MULTIPLE TRAUMA PATIENTS. <i>Lancet</i> 1983; 1 :1270.	190
TRYBA M. RISK OF ACUTE STRESS BLEEDING AND NOSOCOMIAL PNEUMONIA IN VENTILATED INTENSIVE CARE UNIT PATIENTS - SUCRALFATE VERSUS ANTACIDS. <i>American Journal of Medicine</i> 1987; 83 :117-24.	188
CONNORS AF, MCCAFFREE DR, GRAY BA. EVALUATION OF RIGHT HEART CATHETERIZATION IN THE CRITICALLY ILL PATIENT WITHOUT ACUTE MYOCARDIAL INFARCTION. <i>New England Journal of Medicine</i> 1983; 308 :263-7.	188
COOK DJ, FULLER HD, GUYATT GH, MARSHALL JC, LEASA D, HALL R <i>et al</i> . RISK FACTORS FOR GASTROINTESTINAL BLEEDING IN CRITICALLY ILL PATIENTS. <i>New England Journal of Medicine</i> 1994; 330 :377-81.	184
BEDELL SE, PELLE D, MAHER PL, CLEARY PD. DO-NOT-RESUSCITATE ORDERS FOR CRITICALLY ILL PATIENTS IN THE HOSPITAL - HOW ARE THEY USED AND WHAT IS THEIR IMPACT. <i>Journal of the American Medical Association</i> 1986; 256 :233-7.	182
STREAT SJ, BEDDOE AH, HILL GL. AGGRESSIVE NUTRITIONAL SUPPORT DOES NOT PREVENT PROTEIN LOSS DESPITE FAT GAIN IN SEPTIC INTENSIVE CARE PATIENTS. <i>Journal of Trauma-Injury Infection and Critical Care</i> 1987; 27 :262-6.	181
LAUER A, SACCAGGI A, RONCO C, BELLEDONNE M, GLABMAN S, BOSCH JP. CONTINUOUS ARTERIOVENOUS HEMOFILTRATION IN THE CRITICALLY ILL PATIENT - CLINICAL USE AND OPERATIONAL CHARACTERISTICS. <i>Annals of Internal Medicine</i> 1983; 99 :455-60.	178
SLAG MF, MORLEY JE, ELSON MK, CROWSON TW, NUTTALL FQ, SHAFER RB. HYPOTHYROXINEMIA IN CRITICALLY ILL PATIENTS AS A PREDICTOR OF HIGH MORTALITY. <i>Journal of the American Medical Association</i> 1981; 245 :43-5.	176

CRAVEN DE, KUNCHES LM, LICHTENBERG DA, KOLLISCH NR, BARRY MA, HEEREN TC <i>et al.</i> NOSOCOMIAL INFECTION AND FATALITY IN MEDICAL AND SURGICAL INTENSIVE CARE UNIT PATIENTS. <i>Archives of Internal Medicine</i> 1988; 148 :1161-8.	175
KNAUS WA, WAGNER DP, ZIMMERMAN JE, DRAPER EA. VARIATIONS IN MORTALITY AND LENGTH OF STAY IN INTENSIVE CARE UNITS. <i>Annals of Internal Medicine</i> 1993; 118 :753-61.	172
DOEBBELING BN, STANLEY GL, SHEETZ CT, PFALLER MA, HOUSTON AK, ANNIS L <i>et al.</i> COMPARATIVE EFFICACY OF ALTERNATIVE HANDWASHING AGENTS IN REDUCING NOSOCOMIAL INFECTIONS IN INTENSIVE CARE UNITS. <i>New England Journal of Medicine</i> 1992; 327 :88-93.	170
TREMPER KK, SHOEMAKER WC. TRANSCUTANEOUS OXYGEN MONITORING OF CRITICALLY ILL ADULTS, WITH AND WITHOUT LOW FLOW SHOCK. <i>Critical Care Medicine</i> 1981; 9 :706-9.	169
ALS H, LAWHON G, BROWN E, GIBES R, DUFFY FH, MCANULTY G <i>et al.</i> INDIVIDUALIZED BEHAVIORAL AND ENVIRONMENTAL CARE FOR THE VERY- LOW-BIRTH-WEIGHT PRETERM INFANT AT HIGH-RISK FOR BRONCHOPULMONARY DYSPLASIA - NEONATAL INTENSIVE CARE UNIT AND DEVELOPMENTAL OUTCOME. <i>Pediatrics</i> 1986; 78 :1123-32.	168
PANETH N, KIELY JL, WALLENSTEIN S, MARCUS M, PAKTER J, SUSSE M. NEWBORN INTENSIVE CARE AND NEONATAL MORTALITY IN LOW-BIRTH- WEIGHT INFANTS - A POPULATION STUDY. <i>New England Journal of Medicine</i> 1982; 307 :149-55.	167
DETSKY AS, STRICKER SC, MULLEY AG, THIBAUT GE. PROGNOSIS, SURVIVAL, AND THE EXPENDITURE OF HOSPITAL RESOURCES FOR PATIENTS IN AN INTENSIVE CARE UNIT. <i>New England Journal of Medicine</i> 1981; 305 :667-72.	167
KARANFIL LV, MURPHY M, JOSEPHSON A, GAYNES R, MANDEL L, HILL BC <i>et al.</i> A CLUSTER OF VANCOMYCIN-RESISTANT ENTEROCOCCUS FAECIUM IN AN INTENSIVE CARE UNIT. <i>Infection Control and Hospital Epidemiology</i> 1992; 13 :195-200.	166
RICHARDSON DK, GRAY JE, MCCORMICK MC, WORKMAN K, GOLDMANN DA. SCORE FOR NEONATAL ACUTE PHYSIOLOGY - A PHYSIOLOGICAL SEVERITY INDEX FOR NEONATAL INTENSIVE CARE. <i>Pediatrics</i> 1993; 91 :617-23.	161
GASTINNE H, WOLFF M, DELATOUR F, FAURISSON F, CHEVRET S. A CONTROLLED TRIAL IN INTENSIVE CARE UNITS OF SELECTIVE DECONTAMINATION OF THE DIGESTIVE TRACT WITH NONABSORBABLE ANTIBIOTICS. <i>New England Journal of Medicine</i> 1992; 326 :594-9.	159
SALATA RA, LEDERMAN MM, SHLAES DM, JACOBS MR, ECKSTEIN E, TWEARDY D <i>et al.</i> DIAGNOSIS OF NOSOCOMIAL PNEUMONIA IN INTUBATED, INTENSIVE CARE UNIT PATIENTS. <i>American Review of Respiratory Disease</i> 1987; 135 :426-32.	155
SILVERSTEIN MD, SINGER DE, MULLEY AG, THIBAUT GE, BARNETT GO. PATIENTS WITH SYNCOPE ADMITTED TO MEDICAL INTENSIVE CARE UNITS. <i>Journal of the American Medical Association</i> 1982; 248 :1185-9.	151
ROUBY JJ, DELASSALE EM, POETE P, NICOLAS MH, BODIN L, JARLIER V <i>et al.</i> NOSOCOMIAL BRONCHOPNEUMONIA IN THE CRITICALLY ILL - HISTOLOGIC AND BACTERIOLOGICAL ASPECTS. <i>American Review of Respiratory Disease</i> 1992; 146 :1059-66.	149
BRUNBUISSON C, LEGRAND P, RAUSS A, RICHARD C, MONTRAVERS F, BESBES M <i>et al.</i> INTESTINAL DECONTAMINATION FOR CONTROL OF NOSOCOMIAL MULTIRESTANT GRAM-NEGATIVE BACILLI - STUDY OF AN OUTBREAK IN AN INTENSIVE CARE UNIT. <i>Annals of Internal Medicine</i> 1989; 110 :873-81.	149
DASCHNER FD, FREY P, WOLFF G, BAUMANN PC, SUTER P. NOSOCOMIAL INFECTIONS IN INTENSIVE CARE WARDS - A MULTI-CENTER PROSPECTIVE STUDY. <i>Intensive Care Medicine</i> 1982; 8 :5-9.	148
CULLEN DJ, COYLE JP, TEPLICK R, LONG MC. CARDIOVASCULAR, PULMONARY, AND RENAL EFFECTS OF MASSIVELY INCREASED INTRA ABDOMINAL PRESSURE IN CRITICALLY ILL PATIENTS. <i>Critical Care Medicine</i> 1989; 17 :118-21.	145
BOLTON CF, GILBERT JJ, HAHN AF, SIBBALD WJ. POLYNEUROPATHY IN CRITICALLY ILL PATIENTS. <i>Journal of Neurology Neurosurgery and Psychiatry</i> 1984; 47 :1223-31.	142
TAKALA J, RUOKONEN E, WEBSTER NR, NIELSEN MS, ZANDSTRA DF, VUNDELINCKX G <i>et al.</i> INCREASED MORTALITY ASSOCIATED WITH GROWTH HORMONE TREATMENT IN CRITICALLY ILL ADULTS. <i>New England Journal of Medicine</i> 1999; 341 :785-92.	140
ROSS R, MIELL J, FREEMAN E, JONES J, MATTHEWS D, PREECE M <i>et al.</i> CRITICALLY ILL PATIENTS HAVE HIGH BASAL GROWTH HORMONE LEVELS WITH ATTENUATED OSCILLATORY ACTIVITY ASSOCIATED WITH LOW LEVELS OF INSULIN-LIKE GROWTH FACTOR-I. <i>Clinical Endocrinology</i> 1991; 35 :47-54.	139

KNAUS WA, WAGNER DP, LOIRAT P, CULLEN DJ, GLASER P, MERCIER P <i>et al.</i> A COMPARISON OF INTENSIVE CARE IN THE USA AND FRANCE. <i>Lancet</i> 1982; 2 :642-6.	139
YU MH, LEVY MM, SMITH P, TAKIGUCHI SA, MIYASAKI A, MYERS SA. EFFECT OF MAXIMIZING OXYGEN DELIVERY ON MORBIDITY AND MORTALITY RATES IN CRITICALLY ILL PATIENTS - A PROSPECTIVE, RANDOMIZED, CONTROLLED STUDY. <i>Critical Care Medicine</i> 1993; 21 :830-8.	137
BURNIE JP, ODDS FC, LEE W, WEBSTER C, WILLIAMS JD. OUTBREAK OF SYSTEMIC CANDIDA ALBICANS IN INTENSIVE CARE UNIT CAUSED BY CROSS INFECTION. <i>British Medical Journal</i> 1985; 290 :746-8.	136
BRIVET FG, KLEINKNECHT DJ, LOIRAT P, LANDAIS PJM, BEDOCK B, BLEICHNER G <i>et al.</i> ACUTE RENAL FAILURE IN INTENSIVE CARE UNITS - CAUSES, OUTCOME, AND PROGNOSTIC FACTORS OF HOSPITAL MORTALITY: A PROSPECTIVE, MULTICENTER STUDY. <i>Critical Care Medicine</i> 1996; 24 :192-8.	135
PERSSON L, HILLERED L. CHEMICAL MONITORING OF NEUROSURGICAL INTENSIVE CARE PATIENTS USING INTRACEREBRAL MICRODIALYSIS. <i>Journal of Neurosurgery</i> 1992; 76 :72-80.	134
TRAN DD, GROENEVELD ABJ, VANDERMEULEN J, NAUTA JJP, VANSCHIJNDEL RJMS, THIJS LG. AGE, CHRONIC DISEASE, SEPSIS, ORGAN SYSTEM FAILURE, AND MORTALITY IN A MEDICAL INTENSIVE CARE UNIT. <i>Critical Care Medicine</i> 1990; 18 :474-9.	132
WACHTER RM, LUCE JM, TURNER J, VOLBERDING P, HOPEWELL PC. INTENSIVE CARE OF PATIENTS WITH THE ACQUIRED IMMUNODEFICIENCY SYNDROME - OUTCOME AND CHANGING PATTERNS OF UTILIZATION. <i>American Review of Respiratory Disease</i> 1986; 134 :891-6.	131
EISENBERG PR, JAFFE AS, SCHUSTER DP. CLINICAL EVALUATION COMPARED TO PULMONARY ARTERY CATHETERIZATION IN THE HEMODYNAMIC ASSESSMENT OF CRITICALLY ILL PATIENTS. <i>Critical Care Medicine</i> 1984; 12 :549-53.	131
DANIS M, PATRICK DL, SOUTHERLAND LI, GREEN ML. PATIENTS AND FAMILIES PREFERENCES FOR MEDICAL INTENSIVE CARE. <i>Journal of the American Medical Association</i> 1988; 260 :797-802.	131
GRIFFITHS RD, JONES C, PALMER TEA. SIX-MONTH OUTCOME OF CRITICALLY ILL PATIENTS GIVEN GLUTAMINE- SUPPLEMENTED PARENTERAL NUTRITION. <i>Nutrition</i> 1997; 13 :295-302.	129
BAUMGART S, HALL SE, CAMPOS JM, POLIN RA. SEPSIS WITH COAGULASE-NEGATIVE STAPHYLOCOCCI IN CRITICALLY ILL NEWBORNS. <i>American Journal of Diseases of Children</i> 1983; 137 :461-3.	129
SHOEMAKER WC, APPEL PL, WAXMAN K, SCHWARTZ S, CHANG P. CLINICAL TRIAL OF SURVIVORS CARDIORESPIRATORY PATTERNS AS THERAPEUTIC GOALS IN CRITICALLY ILL POSTOPERATIVE PATIENTS. <i>Critical Care Medicine</i> 1982; 10 :398-403.	128
MITCHELL JP, SCHULLER D, CALANDRINO FS, SCHUSTER DP. IMPROVED OUTCOME BASED ON FLUID MANAGEMENT IN CRITICALLY ILL PATIENTS REQUIRING PULMONARY ARTERY CATHETERIZATION. <i>American Review of Respiratory Disease</i> 1992; 145 :990-8.	128
SCHUSTER DP, ROWLEY H, FEINSTEIN S, MCGUE MK, ZUCKERMAN GR. PROSPECTIVE EVALUATION OF THE RISK OF UPPER GASTROINTESTINAL - BLEEDING AFTER ADMISSION TO A MEDICAL INTENSIVE CARE UNIT. <i>American Journal of Medicine</i> 1984; 76 :623-30.	124
POLLACK MM, RUTTIMANN UE, GETSON PR. ACCURATE PREDICTION OF THE OUTCOME OF PEDIATRIC INTENSIVE CARE - A NEW QUANTITATIVE METHOD. <i>New England Journal of Medicine</i> 1987; 316 :134-9.	124
GYS T, HUBENS A, NEELS H, LAUWERS LF, PEETERS R. PROGNOSTIC VALUE OF GASTRIC INTRAMURAL PH IN SURGICAL INTENSIVE CARE PATIENTS. <i>Critical Care Medicine</i> 1988; 16 :1222-4.	123
MCCORMICK MC. LONG-TERM FOLLOW-UP OF INFANTS DISCHARGED FROM NEONATAL INTENSIVE CARE UNITS. <i>Journal of the American Medical Association</i> 1989; 261 :1767-72.	122
WENZEL RP, THOMPSON RL, LANDRY SM, RUSSELL BS, MILLER PJ, DELEON SP <i>et al.</i> HOSPITAL-ACQUIRED INFECTIONS IN INTENSIVE CARE UNIT PATIENTS - AN OVERVIEW WITH EMPHASIS ON EPIDEMICS. <i>Infection Control and Hospital Epidemiology</i> 1983; 4 :371-5.	120
FREEMAN J, GOLDMANN DA, SMITH NE, SIDEBOTTOM DG, EPSTEIN MF, PLATT R. ASSOCIATION OF INTRAVENOUS LIPID EMULSION AND COAGULASE- NEGATIVE STAPHYLOCOCCAL BACTEREMIA IN NEONATAL INTENSIVE CARE UNITS. <i>New England Journal of Medicine</i> 1990; 323 :301-8.	120
SINCLAIR JC, TORRANCE GW, BOYLE MH, HORWOOD SP, SAIGAL S, SACKETT DL. EVALUATION OF NEONATAL INTENSIVE CARE PROGRAMS. <i>New England Journal of Medicine</i> 1981; 305 :489-94.	119

PINILLA JC, ROSS DF, MARTIN T, CRUMP H. STUDY OF THE INCIDENCE OF INTRAVASCULAR CATHETER INFECTION AND ASSOCIATED SEPTICEMIA IN CRITICALLY ILL PATIENTS. <i>Critical Care Medicine</i> 1983; 11 :21-5.	119
GROENEVELD ABJ, TRAN DD, VANDERMEULEN J, NAUTA JJP, THIJS LG. ACUTE RENAL FAILURE IN THE MEDICAL INTENSIVE CARE UNIT - PREDISPOSING, COMPLICATING FACTORS AND OUTCOME. <i>Nephron</i> 1991; 59 :602-10.	118
SINGER DE, CARR PL, MULLEY AG, THIBAUT GE. RATIONING INTENSIVE CARE - PHYSICIAN RESPONSES TO A RESOURCE SHORTAGE. <i>New England Journal of Medicine</i> 1983; 309 :1155-60.	117
KRUSE JA, THILLBAHAROZIAN MC, CARLSON RW. COMPARISON OF CLINICAL ASSESSMENT WITH APACHE-II FOR PREDICTING MORTALITY RISK IN PATIENTS ADMITTED TO A MEDICAL INTENSIVE CARE UNIT. <i>Journal of the American Medical Association</i> 1988; 260 :1739-42.	117
BATTISTI O, MITCHISON R, DAVIES PA. CHANGING BLOOD CULTURE ISOLATES IN A REFERRAL NEONATAL INTENSIVE CARE UNIT. <i>Archives of Disease in Childhood</i> 1981; 56 :775-8.	116
SHORTELL SM, ZIMMERMAN JE, ROUSSEAU DM, GILLIES RR, WAGNER DP, DRAPER EA <i>et al</i> . THE PERFORMANCE OF INTENSIVE CARE UNITS - DOES GOOD MANAGEMENT MAKE A DIFFERENCE. <i>Medical Care</i> 1994; 32 :508-25.	115
MUNSON DP, THOMPSON TR, JOHNSON DE, RHAME FS, VANDRUNEN N, FERRIERI P. COAGULASE-NEGATIVE STAPHYLOCOCCAL SEPTICEMIA - EXPERIENCE IN A NEWBORN INTENSIVE CARE UNIT. <i>Journal of Pediatrics</i> 1982; 101 :602-5.	114
BOLTON CF, LAVERTY DA, BROWN JD, WITT NJ, HAHN AF, SIBBALD WJ. CRITICALLY ILL POLYNEUROPATHY - ELECTROPHYSIOLOGICAL STUDIES AND DIFFERENTIATION FROM GUILLAIN-BARRE SYNDROME. <i>Journal of Neurology Neurosurgery and Psychiatry</i> 1986; 49 :563-73.	114
SCHIERHOUT G, ROBERTS I. FLUID RESUSCITATION WITH COLLOID OR CRYSTALLOID SOLUTIONS IN CRITICALLY ILL PATIENTS: A SYSTEMATIC REVIEW OF RANDOMISED TRIALS. <i>British Medical Journal</i> 1998; 316 :961-4.	112
GOLDMANN DA, DURBIN WA, FREEMAN J. NOSOCOMIAL INFECTIONS IN A NEONATAL INTENSIVE CARE UNIT. <i>Journal of Infectious Diseases</i> 1981; 144 :449-59.	112
SHIPPY CR, APPEL PL, SHOEMAKER WC. RELIABILITY OF CLINICAL MONITORING TO ASSESS BLOOD VOLUME IN CRITICALLY ILL PATIENTS. <i>Critical Care Medicine</i> 1984; 12 :107-12.	111
BRITTON SB, FITZHARDINGE PM, ASHBY S. IS INTENSIVE CARE JUSTIFIED FOR INFANTS WEIGHING LESS THAN 801 GM AT BIRTH. <i>Journal of Pediatrics</i> 1981; 99 :937-43.	111
STRAUSS MJ, LOGERFO JP, YELTATZIE JA, TEMKIN N, HUDSON LD. RATIONING OF INTENSIVE CARE UNIT SERVICES - AN EVERYDAY OCCURRENCE. <i>Journal of the American Medical Association</i> 1986; 255 :1143-6.	110
CALVIN JE, DRIEDGER AA, SIBBALD WJ. DOES THE PULMONARY CAPILLARY WEDGE PRESSURE PREDICT LEFT VENTRICULAR PRELOAD IN CRITICALLY ILL PATIENTS. <i>Critical Care Medicine</i> 1981; 9 :437-43.	108
INGENBLEEK Y, CARPENTIER YA. A PROGNOSTIC INFLAMMATORY AND NUTRITIONAL INDEX SCORING CRITICALLY ILL PATIENTS. <i>International Journal for Vitamin and Nutrition Research</i> 1985; 55 :91-101.	107
HORWOOD SP, BOYLE MH, TORRANCE GW, SINCLAIR JC. MORTALITY AND MORBIDITY OF 500-GRAM TO 1,499-GRAM BIRTH-WEIGHT INFANTS LIVE-BORN TO RESIDENTS OF A DEFINED GEOGRAPHIC REGION BEFORE AND AFTER NEONATAL INTENSIVE CARE. <i>Pediatrics</i> 1982; 69 :613-20.	107
HILLMAN KM, RIORDAN T, OFARRELL SM, TABAQCHALI S. COLONIZATION OF THE GASTRIC CONTENTS IN CRITICALLY ILL PATIENTS. <i>Critical Care Medicine</i> 1982; 10 :444-7.	107
ROWAN KM, KERR JH, MAJOR E, MCPHERSON K, SHORT A, VESSEY MP. INTENSIVE CARE SOCIETY APACHE-II STUDY IN BRITAIN AND IRELAND: OUTCOME COMPARISONS OF INTENSIVE CARE UNITS AFTER ADJUSTMENT FOR CASE-MIX BY THE AMERICAN APACHE-II METHOD. <i>British Medical Journal</i> 1993; 307 :977-81.	106
KNAUS WA, WAGNER DP, LYNN J. SHORT-TERM MORTALITY PREDICTIONS FOR CRITICALLY ILL HOSPITALIZED ADULTS - SCIENCE AND ETHICS. <i>Science</i> 1991; 254 :389-94.	106
WEESEMAYER DE, FONDRIEST DW, BROUILLETTE RT, SHULMAN ST. RISK FACTORS ASSOCIATED WITH CANDIDEMIA IN THE NEONATAL INTENSIVE CARE UNIT - A CASE-CONTROL STUDY. <i>Pediatric Infectious Disease Journal</i> 1987; 6 :190-6.	105

NELSON AH, FLEISHER LA, ROSENBAUM SH. RELATIONSHIP BETWEEN POSTOPERATIVE ANEMIA AND CARDIAC MORBIDITY IN HIGH-RISK VASCULAR PATIENTS IN THE INTENSIVE CARE UNIT. <i>Critical Care Medicine</i> 1993; 21 :860-6.	105
ZIMMERMAN JE, KNAUS WA, SHARPE SM, ANDERSON AS, DRAPER EA, WAGNER DP. THE USE AND IMPLICATIONS OF DO NOT RESUSCITATE ORDERS IN INTENSIVE CARE UNITS. <i>Journal of the American Medical Association</i> 1986; 255 :351-6.	104
MONTECALVO MA, STEGER KA, FARBER HW, SMITH BF, DENNIS RC, FITZPATRICK GF <i>et al.</i> NUTRITIONAL OUTCOME AND PNEUMONIA IN CRITICAL CARE PATIENTS RANDOMIZED TO GASTRIC VERSUS JEJUNAL TUBE FEEDINGS. <i>Critical Care Medicine</i> 1992; 20 :1377-87.	104
MAHER ER, ROBINSON KN, SCOBLE JE, FARRIMOND JG, BROWNE DRG, SWENY P <i>et al.</i> PROGNOSIS OF CRITICALLY ILL PATIENTS WITH ACUTE RENAL FAILURE - APACHE-II SCORE AND OTHER PREDICTIVE FACTORS. <i>Quarterly Journal of Medicine</i> 1989; 72 :857-66.	103
GUTIERREZ G, BISMAR H, DANTZKER DR, SILVA N. COMPARISON OF GASTRIC INTRAMUCOSAL PH WITH MEASURES OF OXYGEN- TRANSPORT AND CONSUMPTION IN CRITICALLY ILL PATIENTS. <i>Critical Care Medicine</i> 1992; 20 :451-7.	103
SLAUGHTER S, HAYDEN MK, NATHAN C, HU TC, RICE T, VANVOORHIS J <i>et al.</i> A COMPARISON OF THE EFFECT OF UNIVERSAL USE OF GLOVES AND GOWNS WITH THAT OF GLOVE USE ALONE ON ACQUISITION OF VANCOMYCIN- RESISTANT ENTEROCOCCI IN A MEDICAL INTENSIVE CARE UNIT. <i>Annals of Internal Medicine</i> 1996; 125 :448-56.	102
SHELLY MP, MENDEL L, PARK GR. FAILURE OF CRITICALLY ILL PATIENTS TO METABOLIZE MIDAZOLAM. <i>Anaesthesia</i> 1987; 42 :619-26.	102
SAIGAL S, ROSENBAUM P, STOSKOPF B, MILNER R. FOLLOW-UP OF INFANTS 501 TO 1,500 GM BIRTH WEIGHT DELIVERED TO RESIDENTS OF A GEOGRAPHICALLY DEFINED REGION WITH PERINATAL INTENSIVE CARE FACILITIES. <i>Journal of Pediatrics</i> 1982; 100 :606-13.	102
PEURA DA, JOHNSON LF. CIMETIDINE FOR PREVENTION AND TREATMENT OF GASTRODUODENAL MUCOSAL LESIONS IN PATIENTS IN AN INTENSIVE CARE UNIT. <i>Annals of Internal Medicine</i> 1985; 103 :173-7.	102
HANSENFLASCHEN J, COWEN J, RAPS EC. NEUROMUSCULAR BLOCKADE IN THE INTENSIVE CARE UNIT - MORE THAN WE BARGAINED FOR. <i>American Review of Respiratory Disease</i> 1993; 147 :234-6.	102
FAGON JY, CHASTRE J, VUAGNAT A, TROUILLET JL, NOVARA A, GIBERT C. NOSOCOMIAL PNEUMONIA AND MORTALITY AMONG PATIENTS IN INTENSIVE CARE UNITS. <i>Journal of the American Medical Association</i> 1996; 275 :866-9.	102
BONE RC, BALK RA, CERRA FB, DELLINGER RP, FEIN AM, KNAUS WA <i>et al.</i> AMERICAN COLLEGE OF CHEST PHYSICIANS SOCIETY OF CRITICAL CARE MEDICINE CONSENSUS CONFERENCE - DEFINITIONS FOR SEPSIS AND ORGAN FAILURE AND GUIDELINES FOR THE USE OF INNOVATIVE THERAPIES IN SEPSIS. <i>Critical Care Medicine</i> 1992; 20 :864-74.	102
SCHUSTER DP, MARION JM. PRECEDENTS FOR MEANINGFUL RECOVERY DURING TREATMENT IN A MEDICAL INTENSIVE CARE UNIT - OUTCOME IN PATIENTS WITH HEMATOLOGIC MALIGNANCY. <i>American Journal of Medicine</i> 1983; 75 :402-8.	101
PRENDERGAST TJ, LUCE JM. INCREASING INCIDENCE OF WITHHOLDING AND WITHDRAWAL OF LIFE SUPPORT FROM THE CRITICALLY ILL. <i>American Journal of Respiratory and Critical Care Medicine</i> 1997; 155 :15-20.	101
JARVIS WR, EDWARDS JR, CULVER DH, HUGHES JM, HORAN T, EMORI TG <i>et al.</i> NOSOCOMIAL INFECTION RATES IN ADULT AND PEDIATRIC INTENSIVE CARE UNITS IN THE UNITED STATES. <i>American Journal of Medicine</i> 1991; 91 :S185-S191.	101
BECKSAGUE CM, JARVIS WR, BROOK JH, CULVER DH, POTTS A, GAY E <i>et al.</i> EPIDEMIC BACTEREMIA DUE TO ACINETOBACTER-BAUMANNII IN 5 INTENSIVE CARE UNITS. <i>American Journal of Epidemiology</i> 1990; 132 :723-33.	101
LIVERMORE DM, YUAN M. ANTIBIOTIC RESISTANCE AND PRODUCTION OF EXTENDED-SPECTRUM BETA- LACTAMASES AMONGST KLEBSIELLA SPP FROM INTENSIVE CARE UNITS IN EUROPE. <i>Journal of Antimicrobial Chemotherapy</i> 1996; 38 :409-24.	100
HINSDALE JG, JAFFE BM. RE-OPERATION FOR INTRA ABDOMINAL SEPSIS - INDICATIONS AND RESULTS IN MODERN CRITICAL CARE SETTING. <i>Annals of Surgery</i> 1984; 199 :31-6.	100

GROUNDS RM, LALOR JM, LUMLEY J, ROYSTON D, MORGAN M. PROPOFOL INFUSION FOR SEDATION IN THE INTENSIVE CARE UNIT – PRELIMINARY-REPORT. <i>British Medical Journal</i> 1987; 294 :397-400.	100
COOK DJ, GUYATT GH, JAESCHKE R, REEVE J, SPANIER A, KING D <i>et al</i> . DETERMINANTS IN CANADIAN HEALTHCARE WORKERS OF THE DECISION TO WITHDRAW LIFE SUPPORT FROM THE CRITICALLY ILL. <i>Journal of the American Medical Association</i> 1995; 273 :703-8.	100
WEISSMAN C, KEMPER M, DAMASK MC, ASKANAZI J, HYMAN AI, KINNEY JM. EFFECT OF ROUTINE INTENSIVE CARE INTERACTIONS ON METABOLIC RATE. <i>Chest</i> 1984; 86 :815-8.	99
HAMMOND JMJ, POTGIETER PD, SAUNDERS GL, FORDER AA. DOUBLE-BLIND-STUDY OF SELECTIVE DECONTAMINATION OF THE DIGESTIVE TRACT IN INTENSIVE CARE. <i>Lancet</i> 1992; 340 :5-9.	99
ZOCHODNE DW, RAMSAY DA, SALLY V, SHELLEY S, MOFFATT S. ACUTE NECROTIZING MYOPATHY OF INTENSIVE CARE - ELECTROPHYSIOLOGICAL STUDIES. <i>Muscle & Nerve</i> 1994; 17 :285-92.	98
REYNOLDS HN, HAUPT MT, THILLBAHAROZIAN MC, CARLSON RW. IMPACT OF CRITICAL CARE PHYSICIAN STAFFING ON PATIENTS WITH SEPTIC SHOCK IN A UNIVERSITY HOSPITAL MEDICAL INTENSIVE CARE UNIT. <i>Journal of the American Medical Association</i> 1988; 260 :3446-50.	98
LEGALL JR, KLAR J, LEMESHOW S, SAULNIER F, ALBERTI C, ARTIGAS A <i>et al</i> . THE LOGISTIC ORGAN DYSFUNCTION SYSTEM - A NEW WAY TO ASSESS ORGAN DYSFUNCTION IN THE INTENSIVE CARE UNIT. <i>Journal of the American Medical Association</i> 1996; 276 :802-10.	98
WOODCOCK BG, RIETBROCK I, VOHRINGER HF, RIETBROCK N. VERAPAMIL DISPOSITION IN LIVER DISEASE AND INTENSIVE CARE PATIENTS - KINETICS, CLEARANCE, AND APPARENT BLOOD FLOW RELATIONSHIPS. <i>Clinical Pharmacology & Therapeutics</i> 1981; 29 :27-34.	97
TREMEL H, KIENLE B, WEILEMANN LS, STEHLE P, FURST P. GLUTAMINE DIPEPTIDE-SUPPLEMENTED PARENTERAL NUTRITION MAINTAINS INTESTINAL FUNCTION IN THE CRITICALLY ILL. <i>Gastroenterology</i> 1994; 107 :1595-601.	97
SMITHIES M, YEE TH, JACKSON L, BEALE R, BIHARI D. PROTECTING THE GUT AND THE LIVER IN THE CRITICALLY ILL - EFFECTS OF DOPEXAMINE. <i>Critical Care Medicine</i> 1994; 22 :789-95.	97
CARRASCO G, MOLINA R, COSTA J, SOLER JM, CABRE L. PROPOFOL VS MIDAZOLAM IN SHORT-TERM, MEDIUM-TERM, AND LONG-TERM SEDATION OF CRITICALLY ILL PATIENTS - A COST-BENEFIT-ANALYSIS. <i>Chest</i> 1993; 103 :557-64.	97
PATRICK DL, DANIS M, SOUTHERLAND LI, HONG GY. QUALITY OF LIFE FOLLOWING INTENSIVE CARE. <i>Journal of General Internal Medicine</i> 1988; 3 :218-23.	96
CHERTOW GM, CHRISTIANSEN CL, CLEARY PD, MUNRO C, LAZARUS JM. PROGNOSTIC STRATIFICATION IN CRITICALLY ILL PATIENTS WITH ACUTE RENAL FAILURE REQUIRING DIALYSIS. <i>Archives of Internal Medicine</i> 1995; 155 :1505-11.	95
BAELE PL, MCMICHAN JC, MARSH HM, SILL JC, SOUTHORN PA. CONTINUOUS MONITORING OF MIXED VENOUS OXYGEN-SATURATION IN CRITICALLY ILL PATIENTS. <i>Anesthesia and Analgesia</i> 1982; 61 :513-7.	95
ZIEGLER TR, YOUNG LS, FERRARIBALIVIERA E, DEMLING RH, WILMORE DW. USE OF HUMAN GROWTH HORMONE COMBINED WITH NUTRITIONAL SUPPORT IN A CRITICAL CARE UNIT. <i>Journal of Parenteral and Enteral Nutrition</i> 1990; 14 :574-81.	94
YOUNGNER SJ, LEWANDOWSKI W, MCCLISH DK, JUKNIALIS BW, COULTON C, BARTLETT ET. DO-NOT -RESUSCITATE ORDERS - INCIDENCE AND IMPLICATIONS IN A MEDICAL INTENSIVE CARE UNIT. <i>Journal of the American Medical Association</i> 1985; 253 :54-7.	93
LEGALL JR, LOIRAT P, ALPEROVITCH A. SIMPLIFIED ACUTE PHYSIOLOGICAL SCORE FOR INTENSIVE CARE PATIENTS. <i>Lancet</i> 1983; 2 :741.	93
LANGER M, MOSCONI P, CIGADA M, MANDELLI M. LONG-TERM RESPIRATORY SUPPORT AND RISK OF PNEUMONIA IN CRITICALLY ILL PATIENTS. <i>American Review of Respiratory Disease</i> 1989; 140 :302-5.	93
DONOWITZ LG, PAGE MC, MILEUR BL, GUENTHNER SH. ALTERATION OF NORMAL GASTRIC FLORA IN CRITICAL CARE PATIENTS RECEIVING ANTACID AND CIMETIDINE THERAPY. <i>Infection Control and Hospital Epidemiology</i> 1986; 7 :23-6.	93
CHANG RWS, JACOBS S, LEE B, PACE N. PREDICTING DEATHS AMONG INTENSIVE CARE UNIT PATIENTS. <i>Critical Care Medicine</i> 1988; 16 :34-42.	93

ALVAREZLERMA F, PELLUS AM, SANCHEZ BA, ORTIZ EP, JORDA R, BARCENILLA F <i>et al.</i> MODIFICATION OF EMPIRIC ANTIBIOTIC TREATMENT IN PATIENTS WITH PNEUMONIA ACQUIRED IN THE INTENSIVE CARE UNIT. <i>Intensive Care Medicine</i> 1996; 22 :387-94.	93
LEMESHOW S, TERES D, AVRUNIN JS, GAGE RW. REFINING INTENSIVE CARE UNIT OUTCOME PREDICTION BY USING CHANGING PROBABILITIES OF MORTALITY. <i>Critical Care Medicine</i> 1988; 16 :470-7.	92
ASCH DA, HANSENFLASCHEN J, LANKEN PN. DECISIONS TO LIMIT OR CONTINUE LIFE-SUSTAINING TREATMENT BY CRITICAL CARE PHYSICIANS IN THE UNITED-STATES - CONFLICTS BETWEEN PHYSICIANS PRACTICES AND PATIENTS WISHES. <i>American Journal of Respiratory and Critical Care Medicine</i> 1995; 151 :288-92.	92
KNAUS WA, DRAPER EA, WAGNER DP, ZIMMERMAN JE, BIRNBAUM ML, CULLEN DJ <i>et al.</i> EVALUATING OUTCOME FROM INTENSIVE CARE - A PRELIMINARY MULTI-HOSPITAL COMPARISON. <i>Critical Care Medicine</i> 1982; 10 :491-6.	91
JONES PA, ANDREWS PJD, MIDGLEY S, ANDERSON SI, PIPER IR, TOCHER JL <i>et al.</i> MEASURING THE BURDEN OF SECONDARY INSULTS IN HEAD-INJURED PATIENTS DURING INTENSIVE CARE. <i>Journal of Neurosurgical Anesthesiology</i> 1994; 6 :4-14.	91
FANCONI S, DOHERTY P, EDMONDS JF, BARKER GA, BOHN DJ. PULSE OXIMETRY IN PEDIATRIC INTENSIVE CARE - COMPARISON WITH MEASURED SATURATIONS AND TRANS CUTANEOUS OXYGEN-TENSION. <i>Journal of Pediatrics</i> 1985; 107 :362-6.	91
ROUBY JJ, LAURENT P, GOSNACH M, CAMBAU E, LAMAS G, ZOUAOUI A <i>et al.</i> RISK FACTORS AND CLINICAL RELEVANCE OF NOSOCOMIAL MAXILLARY SINUSITIS IN THE CRITICALLY ILL. <i>American Journal of Respiratory and Critical Care Medicine</i> 1994; 150 :776-83.	90
PEARSON AC, CASTELLO R, LABOVITZ AJ, SULLIVAN N, OJILE M. SAFETY AND UTILITY OF TRANS-ESOPHAGEAL ECHOCARDIOGRAPHY IN THE CRITICALLY ILL PATIENT. <i>American Heart Journal</i> 1990; 119 :1083-9.	90
VANDENBROUCKEGRAULS CMJE, VANDENBROUCKE JP. EFFECT OF SELECTIVE DECONTAMINATION OF THE DIGESTIVE TRACT ON RESPIRATORY TRACT INFECTIONS AND MORTALITY IN THE INTENSIVE CARE UNIT. <i>Lancet</i> 1991; 338 :859-62.	89
SCHAEFER JH, JOCHIMSEN F, KELLER F, WEGSCHEIDER K, DISTLER A. OUTCOME PREDICTION OF ACUTE RENAL FAILURE IN MEDICAL INTENSIVE CARE. <i>Intensive Care Medicine</i> 1991; 17 :19-24.	89
CHEVRET S, HEMMER M, CARLET J, LANGER M. INCIDENCE AND RISK FACTORS OF PNEUMONIA ACQUIRED IN INTENSIVE CARE UNITS - RESULTS FROM A MULTICENTER PROSPECTIVE STUDY ON 996 PATIENTS. <i>Intensive Care Medicine</i> 1993; 19 :256-64.	89
SHOEMAKER WC, APPEL P, BLAND R. USE OF PHYSIOLOGIC MONITORING TO PREDICT OUTCOME AND TO ASSIST IN CLINICAL DECISIONS IN CRITICALLY ILL POSTOPERATIVE PATIENTS. <i>American Journal of Surgery</i> 1983; 146 :43-50.	88
STOCK MC, WOODWARD CG, SHAPIRO BA, CANE RD, LEWIS V, PECARO B. PERIOPERATIVE COMPLICATIONS OF ELECTIVE TRACHEOSTOMY IN CRITICALLY ILL PATIENTS. <i>Critical Care Medicine</i> 1986; 14 :861-3.	87
KELLY TWJ, PATRICK MR, HILLMAN KM. STUDY OF DIARRHEA IN CRITICALLY ILL PATIENTS. <i>Critical Care Medicine</i> 1983; 11 :7-9.	87
HARTSTEIN AI, RASHAD AL, LIEBLER JM, ACTIS LA, FREEMAN J, ROURKE JW <i>et al.</i> MULTIPLE INTENSIVE CARE UNIT OUTBREAK OF ACINETOBACTER CALCOACETICUS SUBSPECIES ANITRATUS RESPIRATORY INFECTION AND COLONIZATION ASSOCIATED WITH CONTAMINATED, REUSABLE VENTILATOR CIRCUITS AND RESUSCITATION BAGS. <i>American Journal of Medicine</i> 1988; 85 :624-31.	87
WILSON WC, SMEDIRA NG, FINK C, MCDOWELL JA, LUCE JM. ORDERING AND ADMINISTRATION OF SEDATIVES AND ANALGESICS DURING THE WITHHOLDING AND WITHDRAWAL OF LIFE SUPPORT FROM CRITICALLY ILL PATIENTS. <i>Journal of the American Medical Association</i> 1992; 267 :949-53.	86
WAGNER DP, KNAUS WA, HARRELL FE, ZIMMERMAN JE, WATTS C. DAILY PROGNOSTIC ESTIMATES FOR CRITICALLY ILL ADULTS IN INTENSIVE CARE UNITS - RESULTS FROM A PROSPECTIVE, MULTICENTER, INCEPTION COHORT ANALYSIS. <i>Critical Care Medicine</i> 1994; 22 :1359-72.	86
PITTET D, MONOD M, SUTER PM, FRENK E, AUCKENTHALER R. CANDIDA COLONIZATION AND SUBSEQUENT INFECTIONS IN CRITICALLY ILL SURGICAL PATIENTS. <i>Annals of Surgery</i> 1994; 220 :751-8.	86

ELKAYAM U, BERKLEY R, AZEN S, WEBER L, GEVA B, HENRY WL. CARDIAC OUTPUT BY THERMO-DILUTION TECHNIQUE - EFFECT OF INJECTATES VOLUME AND TEMPERATURE ON ACCURACY AND REPRODUCIBILITY IN THE CRITICALLY ILL PATIENT. <i>Chest</i> 1983; 84 :418-22.	86
CHERNOW B, RAINEY TG, LAKE CR. ENDOGENOUS AND EXOGENOUS CATECHOLAMINES IN CRITICAL CARE MEDICINE. <i>Critical Care Medicine</i> 1982; 10 :409-16.	86
KEENAN RA, MOLDAWER LL, YANG RD, KAWAMURA I, BLACKBURN GL, BISTRAN BR. AN ALTERED RESPONSE BY PERIPHERAL LEUKOCYTES TO SYNTHESIZE OR RELEASE LEUKOCYTE ENDOGENOUS MEDIATOR IN CRITICALLY ILL, PROTEIN-MALNOURISHED PATIENTS. <i>Journal of Laboratory and Clinical Medicine</i> 1982; 100 :844-57.	85
HORBAR JD, MCAULIFFE TL, ADLER SM, ALBERSHEIM S, CASSADY G, EDWARDS W <i>et al</i> . VARIABILITY IN 28-DAY OUTCOMES FOR VERY-LOW-BIRTH-WEIGHT INFANTS - AN ANALYSIS OF 11 NEONATAL INTENSIVE CARE UNITS. <i>Pediatrics</i> 1988; 82 :554-9.	85
COOPER DJ, WALLEY KR, WIGGS BR, RUSSELL JA. BICARBONATE DOES NOT IMPROVE HEMODYNAMICS IN CRITICALLY ILL PATIENTS WHO HAVE LACTIC ACIDOSIS - A PROSPECTIVE, CONTROLLED CLINICAL STUDY. <i>Annals of Internal Medicine</i> 1990; 112 :492-8.	85
LI TCM, PHILLIPS MC, SHAW L, COOK EF, NATANSON C, GOLDMAN L. ON-SITE PHYSICIAN STAFFING IN A COMMUNITY HOSPITAL INTENSIVE CARE UNIT - IMPACT ON TEST AND PROCEDURE USE AND ON PATIENT OUTCOME. <i>Journal of the American Medical Association</i> 1984; 252 :2023-7.	84
LEGALL JR, BRUNBUISSON C, TRUNET P, LATOURNERIE J, CHANTEREAU S, RAPIN M. INFLUENCE OF AGE, PREVIOUS HEALTH STATUS, AND SEVERITY OF ACUTE ILLNESS ON OUTCOME FROM INTENSIVE CARE. <i>Critical Care Medicine</i> 1982; 10 :575-7.	84
HEFFNER JE, MILLER KS, SAHN SA. TRACHEOSTOMY IN THE INTENSIVE CARE UNIT: 2COMPLICATIONS. <i>Chest</i> 1986; 90 :430-6.	84
DAVENPORT A, WILL EJ, DAVIDSON AM. IMPROVED CARDIOVASCULAR STABILITY DURING CONTINUOUS MODES OF RENAL REPLACEMENT THERAPY IN CRITICALLY ILL PATIENTS WITH ACUTE HEPATIC AND RENAL FAILURE. <i>Critical Care Medicine</i> 1993; 21 :328-38.	84
CAMPION EW, MULLEY AG, GOLDSTEIN RL, BARNETT GO, THIBAUT GE. MEDICAL INTENSIVE CARE FOR THE ELDERLY - A STUDY OF CURRENT USE, COSTS, AND OUTCOMES. <i>Journal of the American Medical Association</i> 1981; 246 :2052-6.	84
BERGMAN I, PAINTER MJ, HIRSCH RP, CRUMRINE PK, DAVID R. OUTCOME IN NEONATES WITH CONVULSIONS TREATED IN AN INTENSIVE CARE UNIT. <i>Annals of Neurology</i> 1983; 14 :642-7.	84
AITKENHEAD AR, WILLATTS SM, PARK GR, COLLINS CH, LEDINGHAM IM, PEPPERMAN ML <i>et al</i> . COMPARISON OF PROPOFOL AND MIDAZOLAM FOR SEDATION IN CRITICALLY ILL PATIENTS. <i>Lancet</i> 1989; 2 :704-9.	84
GUEST TM, RAMANATHAN AV, TUTEUR PG, SCHECHTMAN KB, LADENSON JH, JAFFE AS. MYOCARDIAL INJURY IN CRITICALLY ILL PATIENTS - A FREQUENTLY UNRECOGNIZED COMPLICATION. <i>Journal of the American Medical Association</i> 1995; 273 :1945-9.	83
FAIX RG. SYSTEMIC CANDIDA INFECTIONS IN INFANTS IN INTENSIVE CARE NURSERIES - HIGH INCIDENCE OF CENTRAL NERVOUS SYSTEM INVOLVEMENT. <i>Journal of Pediatrics</i> 1984; 105 :616-22.	83
CRAIG CP, CONNELLY S. EFFECT OF INTENSIVE CARE UNIT NOSOCOMIAL PNEUMONIA ON DURATION OF STAY AND MORTALITY. <i>American Journal of Infection Control</i> 1984; 12 :233-8.	83
BYATT CM, LEWIS LD, DAWLING S, COCHRANE GM. ACCUMULATION OF MIDAZOLAM AFTER REPEATED DOSAGE IN PATIENTS RECEIVING MECHANICAL VENTILATION IN AN INTENSIVE CARE UNIT. <i>British Medical Journal</i> 1984; 289 :799-800.	83
WESTENSKOW DR, CUTLER CA, WALLACE WD. INSTRUMENTATION FOR MONITORING GAS-EXCHANGE AND METABOLIC RATE IN CRITICALLY ILL PATIENTS. <i>Critical Care Medicine</i> 1984; 12 :183-7.	82
LICHTWARCKASCHOFF M, ZERAVIK J, PFEIFFER UJ. INTRATHORACIC BLOOD VOLUME ACCURATELY REFLECTS CIRCULATORY VOLUME STATUS IN CRITICALLY ILL PATIENTS WITH MECHANICAL VENTILATION. <i>Intensive Care Medicine</i> 1992; 18 :142-7.	82
BAKER JP, DETSKY AS, STEWART S, WHITWELL J, MARLISS EB, JEEJEEBHOY KN. RANDOMIZED TRIAL OF TOTAL PARENTERAL NUTRITION IN CRITICALLY ILL PATIENTS - METABOLIC EFFECTS OF VARYING GLUCOSE-LIPID RATIOS AS THE ENERGY SOURCE. <i>Gastroenterology</i> 1984; 87 :53-9.	82
ZIPSER RD, DAVENPORT MW, MARTIN KL, TUCK ML, WARNER NE, SWINNEY RR <i>et al</i> . HYPERRENINEMIC HYPOALDOSTERONISM IN THE CRITICALLY ILL - A NEW ENTITY. <i>Journal of Clinical Endocrinology and Metabolism</i> 1981; 53 :867-73.	81

SEGREDO V, MATTHAY MA, SHARMA ML, GRUENKE LD, CALDWELL JE, MILLER RD. PROLONGED NEUROMUSCULAR BLOCKADE AFTER LONG-TERM ADMINISTRATION OF VECURONIUM IN 2 CRITICALLY ILL PATIENTS. <i>Anesthesiology</i> 1990; 72 :566-70.	81
RONCO JJ, FENWICK JC, TWEEDDALE MG, WIGGS BR, PHANG PT, COOPER DJ <i>et al.</i> IDENTIFICATION OF THE CRITICAL OXYGEN DELIVERY FOR ANAEROBIC METABOLISM IN CRITICALLY ILL SEPTIC AND NONSEPTIC HUMANS. <i>Journal of the American Medical Association</i> 1993; 270 :1724-30.	81
RODRIGUEZ JL, STEINBERG SM, LUCHETTI FA, GIBBONS KJ, TAHERI PA, FLINT LM. EARLY TRACHEOSTOMY FOR PRIMARY AIRWAY MANAGEMENT IN THE SURGICAL CRITICAL CARE SETTING. <i>Surgery</i> 1990; 108 :655-9.	81
RASHKIN MC, BOSKEN C, BAUGHMAN RP. OXYGEN DELIVERY IN CRITICALLY ILL PATIENTS - RELATIONSHIP TO BLOOD LACTATE AND SURVIVAL. <i>Chest</i> 1985; 87 :580-4.	81
KNAUS WA, WAGNER DP, DRAPER EA, LAWRENCE DE, ZIMMERMAN JE. THE RANGE OF INTENSIVE CARE SERVICES TODAY. <i>Journal of the American Medical Association</i> 1981; 246 :2711-6.	81
GHAJAR J, HARIRI RJ, NARAYAN RK, IACONO LA, FIRLIK K, PATTERSON RH. SURVEY OF CRITICAL CARE MANAGEMENT OF COMATOSE, HEAD-INJURED PATIENTS IN THE UNITED STATES. <i>Critical Care Medicine</i> 1995; 23 :560-7.	81
FANIEL R, SCHOENFELD P. EFFICACY OF IV AMIODARONE IN CONVERTING RAPID ATRIAL FIBRILLATION AND FLUTTER TO SINUS RHYTHM IN INTENSIVE CARE PATIENTS. <i>European Heart Journal</i> 1983; 4 :180-5.	81
SCHAPIRA DV, STUDNICKI J, BRADHAM DD, WOLFF P, JARRETT A. INTENSIVE CARE, SURVIVAL, AND EXPENSE OF TREATING CRITICALLY ILL CANCER PATIENTS. <i>Journal of the American Medical Association</i> 1993; 269 :783-6.	80
SAGE WM, ROSENTHAL MH, SILVERMAN JF. IS INTENSIVE CARE WORTH IT - AN ASSESSMENT OF INPUT AND OUTCOME FOR THE CRITICALLY ILL. <i>Critical Care Medicine</i> 1986; 14 :777-82.	80
RUBLI E, BUSSARD S, FREI E, LUNDSGAARDHANSEN P, PAPPOVA E. PLASMA FIBRONECTIN AND ASSOCIATED VARIABLES IN SURGICAL INTENSIVE CARE PATIENTS. <i>Annals of Surgery</i> 1983; 197 :310-7.	80
RICHET H, HUBERT B, NITEMBERG G, ANDREMONT A, BUJHOI A, OURBAK P <i>et al.</i> PROSPECTIVE MULTICENTER STUDY OF VASCULAR-CATHETER-RELATED COMPLICATIONS AND RISK FACTORS FOR POSITIVE CENTRAL CATHETER CULTURES IN INTENSIVE CARE UNIT PATIENTS. <i>Journal of Clinical Microbiology</i> 1990; 28 :2520-5.	80
POLLACK MM, KATZ RW, RUTTIMANN UE, GETSON PR. IMPROVING THE OUTCOME AND EFFICIENCY OF INTENSIVE CARE - THE IMPACT OF AN INTENSIVIST. <i>Critical Care Medicine</i> 1988; 16 :11-7.	80
OH JK, SEWARD JB, KHANDHERIA BK, GERSH BJ, MCGREGOR CGA, FREEMAN WK <i>et al.</i> TRANS-ESOPHAGEAL ECHOCARDIOGRAPHY IN CRITICALLY ILL PATIENTS. <i>American Journal of Cardiology</i> 1990; 66 :1492-5.	80
NEWMAN LH, MCDONALD JC, WALLACE PGM, LEDINGHAM IM. PROPOFOL INFUSION FOR SEDATION IN INTENSIVE CARE. <i>Anaesthesia</i> 1987; 42 :929-37.	80
HEYLAND D,MANDELL LA. GASTRIC COLONIZATION BY GRAM-NEGATIVE BACILLI AND NOSOCOMIAL PNEUMONIA IN THE INTENSIVE CARE UNIT PATIENT - EVIDENCE FOR CAUSATION. <i>Chest</i> 1992; 101 :187-93.	80
COOK DJ, WITT LG, COOK RJ, GUYATT GH. STRESS ULCER PROPHYLAXIS IN THE CRITICALLY ILL - A METAANALYSIS. <i>American Journal of Medicine</i> 1991; 91 :519-27.	80
JACOBS S, CHANG RWS, LEE B, BARTLETT FW. CONTINUOUS ENTERAL FEEDING - A MAJOR CAUSE OF PNEUMONIA AMONG VENTILATED INTENSIVE CARE UNIT PATIENTS. <i>Journal of Parenteral and Enteral Nutrition</i> 1990; 14 :353-6.	79
DENARDO SJ, OYE RK, BELLAMY PE. EFFICACY OF INTENSIVE CARE FOR BONE MARROW TRANSPLANT PATIENTS WITH RESPIRATORY FAILURE. <i>Critical Care Medicine</i> 1989; 17 :4-6.	79
D'AMICO R, PIFFERI S, LEONETTI C, TORRI V, TINAZZI A, LIBERATI A. EFFECTIVENESS OF ANTIBIOTIC PROPHYLAXIS IN CRITICALLY ILL ADULT PATIENTS: SYSTEMATIC REVIEW OF RANDOMISED CONTROLLED TRIALS. <i>British Medical Journal</i> 1998; 316 :1275-85.	79
ORLANDO R, GLEASON E, DREZNER AD. ACUTE ACALCULOUS CHOLECYSTITIS IN THE CRITICALLY ILL PATIENT. <i>American Journal of Surgery</i> 1983; 145 :472-6.	78
JACOBS P,NOSEWORTHY TW. NATIONAL ESTIMATES OF INTENSIVE CARE UTILIZATION AND COSTS - CANADA AND THE UNITED STATES. <i>Critical Care Medicine</i> 1990; 18 :1282-6.	78

GOLDMAN L, COOK EF, JOHNSON PA, Brand DA, ROUAN GW, LEE TH. PREDICTION OF THE NEED FOR INTENSIVE CARE IN PATIENTS WHO COME TO EMERGENCY DEPARTMENTS WITH ACUTE CHEST PAIN. <i>New England Journal of Medicine</i> 1996; 334 :1498-504.	78
ZIMMERMAN JE, SHORTELL SM, ROUSSEAU DM, DUFFY J, GILLIES RR, KNAUS WA <i>et al</i> . IMPROVING INTENSIVE CARE - OBSERVATIONS BASED ON ORGANIZATIONAL CASE STUDIES IN 9 INTENSIVE CARE UNITS - A PROSPECTIVE, MULTICENTER STUDY. <i>Critical Care Medicine</i> 1993; 21 :1443-51.	77
ROWAN KM, KERR JH, MAJOR E, MCPHERSON K, SHORT A, VESSEY MP. INTENSIVE CARE SOCIETY APACHE-II STUDY IN BRITAIN AND IRELAND: VARIATIONS IN CASE-MIX OF ADULT ADMISSIONS TO GENERAL INTENSIVE CARE UNITS AND IMPACT ON OUTCOME. <i>British Medical Journal</i> 1993; 307 :972-7.	77
MAYNARD ND, BIHARI DJ, DALTON RN, SMITHIES MN, MASON RC. INCREASING SPLANCHNIC BLOOD FLOW IN THE CRITICALLY ILL. <i>Chest</i> 1995; 108 :1648-54.	77
FLEER A, SENDERS RC, VISSER MR, BIJLMER RP, GERARDS LJ, KRAAIJEVELD CA <i>et al</i> . SEPTICEMIA DUE TO COAGULASE-NEGATIVE STAPHYLOCOCCI IN A NEONATAL INTENSIVE CARE UNIT - CLINICAL AND BACTERIOLOGICAL FEATURES AND CONTAMINATED PARENTERAL FLUIDS AS A SOURCE OF SEPSIS. <i>Pediatric Infectious Disease Journal</i> 1983; 2 :426-31.	77
FAGON JY, CHASTRE J, NOVARA A, MEDIONI P, GIBERT C. CHARACTERIZATION OF INTENSIVE CARE UNIT PATIENTS USING A MODEL BASED ON THE PRESENCE OR ABSENCE OF ORGAN DYSFUNCTIONS AND OR INFECTION - THE ODIN MODEL. <i>Intensive Care Medicine</i> 1993; 19 :137-44.	77
CARSON SS, STOCKING C, PODSADECKI T, CHRISTENSON J, POHLMAN A, MACRAE S <i>et al</i> . EFFECTS OF ORGANIZATIONAL CHANGE IN THE MEDICAL INTENSIVE CARE UNIT OF A TEACHING HOSPITAL - A COMPARISON OF 'OPEN' AND 'CLOSED' FORMATS. <i>Journal of the American Medical Association</i> 1996; 276 :322-8.	77
BROWN JJ, SULLIVAN G. EFFECT ON ICU MORTALITY OF A FULL-TIME CRITICAL CARE SPECIALIST. <i>Chest</i> 1989; 96 :127-9.	77
ZIMMERMAN JE, KNAUS WA, JUDSON JA, HAVILL JH, TRUBUHOVICH RV, DRAPER EA <i>et al</i> . PATIENT SELECTION FOR INTENSIVE CARE - A COMPARISON OF NEW ZEALAND AND UNITED STATES HOSPITALS. <i>Critical Care Medicine</i> 1988; 16 :318-26.	76
STEIN L, OZDAMAR O, KRAUS N, PATON J. FOLLOW-UP OF INFANTS SCREENED BY AUDITORY BRAIN STEM RESPONSE IN THE NEONATAL INTENSIVE CARE UNIT. <i>Journal of Pediatrics</i> 1983; 103 :447-53.	76
SOUTHALL DP, RICHARDS JM, RHODEN KJ, ALEXANDER JR, SHINEBOURNE EA, ARROWSMITH WA <i>et al</i> . PROLONGED APNEA AND CARDIAC ARRHYTHMIAS IN INFANTS DISCHARGED FROM NEONATAL INTENSIVE CARE UNITS - FAILURE TO PREDICT AN INCREASED RISK FOR SUDDEN INFANT DEATH SYNDROME. <i>Pediatrics</i> 1982; 70 :844-51.	76
KLEIN BS, PERLOFF WH, MAKI DG. REDUCTION OF NOSOCOMIAL INFECTION DURING PEDIATRIC INTENSIVE CARE BY PROTECTIVE ISOLATION. <i>New England Journal of Medicine</i> 1989; 320 :1714-21.	76
TOCINO IM, MILLER MH, FAIRFAX WR. DISTRIBUTION OF PNEUMOTHORAX IN THE SUPINE AND SEMI-RECUMBENT CRITICALLY ILL ADULT. <i>American Journal of Roentgenology</i> 1985; 144 :901-5.	75
SENEFF MG, WAGNER DP, WAGNER RP, ZIMMERMAN JE, KNAUS WA. HOSPITAL AND 1-YEAR SURVIVAL OF PATIENTS ADMITTED TO INTENSIVE CARE UNITS WITH ACUTE EXACERBATION OF CHRONIC OBSTRUCTIVE PULMONARY DISEASE. <i>Journal of the American Medical Association</i> 1995; 274 :1852-7.	75
OYE RK, BELLAMY PE. PATTERNS OF RESOURCE CONSUMPTION IN MEDICAL INTENSIVE CARE. <i>Chest</i> 1991; 99 :685-9.	75
NANNI G, SIEGEL JH, COLEMAN B, FADER P, CASTIGLIONE R. INCREASED LIPID FUEL DEPENDENCE IN THE CRITICALLY ILL SEPTIC PATIENT. <i>Journal of Trauma-Injury Infection and Critical Care</i> 1984; 24 :14-30.	75
APELGREN KN, ROMBEAU JL, TWOMEY PL, MILLER RA. COMPARISON OF NUTRITIONAL INDEXES AND OUTCOME IN CRITICALLY ILL PATIENTS. <i>Critical Care Medicine</i> 1982; 10 :305-7.	75
ZAROSLINSKI J, BORGMAN RJ, O'DONNELL JP, ANDERSON WG, ERHARDT PW, KAM ST <i>et al</i> . ULTRASHORT ACTING BETA-BLOCKERS - A PROPOSAL FOR THE TREATMENT OF THE CRITICALLY ILL PATIENT. <i>Life Sciences</i> 1982; 31 :899-907.	74
PHIBBS CS, WILLIAMS RL, PHIBBS RH. NEWBORN RISK FACTORS AND COSTS OF NEONATAL INTENSIVE CARE. <i>Pediatrics</i> 1981; 68 :313-21.	74

MAKITA K, NUNN JF, ROYSTON B. EVALUATION OF METABOLIC MEASURING-INSTRUMENTS FOR USE IN CRITICALLY ILL PATIENTS. <i>Critical Care Medicine</i> 1990; 18 :638-44.	74
MARTIN C, PERRIN G, GEVAUDAN MJ, SAUX P, GOUIN F. HEAT AND MOISTURE EXCHANGERS AND VAPORIZING HUMIDIFIERS IN THE INTENSIVE CARE UNIT. <i>Chest</i> 1990; 97 :144-9.	73
PEMBERTON LB, LYMAN B, LANDER V, COVINSKY J. SEPSIS FROM TRIPLE-LUMEN VS SINGLE-LUMEN CATHETERS DURING TOTAL PARENTERAL NUTRITION IN SURGICAL OR CRITICALLY ILL PATIENTS. <i>Archives of Surgery</i> 1986; 121 :591-4.	72
JOSHI N, LOCALIO AR, HAMORY BH. A PREDICTIVE RISK INDEX FOR NOSOCOMIAL PNEUMONIA IN THE INTENSIVE CARE UNIT. <i>American Journal of Medicine</i> 1992; 93 :135-42.	72
HEYLAND DK, COOK DJ, GUYATT GH. ENTERAL NUTRITION IN THE CRITICALLY ILL PATIENT - A CRITICAL REVIEW OF THE EVIDENCE. <i>Intensive Care Medicine</i> 1993; 19 :435-42.	72
DRAGSTED L, JORGENSEN J, JENSEN NH, BONSING E, JACOBSEN E, KNAUS WA <i>et al.</i> INTER-HOSPITAL COMPARISONS OF PATIENT OUTCOME FROM INTENSIVE CARE - IMPORTANCE OF LEAD-TIME BIAS. <i>Critical Care Medicine</i> 1989; 17 :418-22.	72
VANSONNENBERG E, WING VW, CASOLA G, COONS HG, NAKAMOTO SK, MUELLER PR <i>et al.</i> TEMPORIZING EFFECT OF PERCUTANEOUS DRAINAGE OF COMPLICATED ABSCESSSES IN CRITICALLY ILL PATIENTS. <i>American Journal of Roentgenology</i> 1984; 142 :821-6.	71
RAPOPORT J, TERES D, LEMESHOW S, GEHLBACH S. A METHOD FOR ASSESSING THE CLINICAL PERFORMANCE AND COST- EFFECTIVENESS OF INTENSIVE CARE UNITS - A MULTICENTER INCEPTION COHORT STUDY. <i>Critical Care Medicine</i> 1994; 22 :1385-91.	71
POLLACK MM, CUERDON TT, PATEL KM, RUTTIMANN UE, GETSON PR, LEVETOWN M. IMPACT OF QUALITY OF CARE FACTORS ON PEDIATRIC INTENSIVE-CARE UNIT MORTALITY. <i>Journal of the American Medical Association</i> 1994; 272 :941-6.	71
NOBLE RC, KANE MA, REEVES SA, ROECKEL I. POSTTRANSFUSION HEPATITIS-A IN A NEONATAL INTENSIVE CARE UNIT. <i>Journal of the American Medical Association</i> 1984; 252 :2711-5.	71
KANDEL G, ABERMAN A. MIXED VENOUS OXYGEN-SATURATION - ITS ROLE IN THE ASSESSMENT OF THE CRITICALLY ILL PATIENT. <i>Archives of Internal Medicine</i> 1983; 143 :1400-2.	71
ITOKAZU GS, QUINN JP, BELLDIXON C, KAHAN FM, WEINSTEIN RA. ANTIMICROBIAL RESISTANCE RATES AMONG AEROBIC GRAM-NEGATIVE BACILLI RECOVERED FROM PATIENTS IN INTENSIVE CARE UNITS: EVALUATION OF A NATIONAL POSTMARKETING SURVEILLANCE PROGRAM. <i>Clinical Infectious Diseases</i> 1996; 23 :779-84.	71
FIELD T, IGNATOFF E, STRINGER S, BRENNAN J, GREENBERG R, WIDMAYER S <i>et al.</i> NON-NUTRITIVE SUCKING DURING TUBE FEEDINGS - EFFECTS ON PRETERM NEONATES IN AN INTENSIVE CARE UNIT. <i>Pediatrics</i> 1982; 70 :381-4.	71
DUKE GJ, BRIEDIS JH, WEAVER RA. RENAL SUPPORT IN CRITICALLY ILL PATIENTS - LOW-DOSE DOPAMINE OR LOW-DOSE DOBUTAMINE. <i>Critical Care Medicine</i> 1994; 22 :1919-25.	71
CHASSIN MR. COSTS AND OUTCOMES OF MEDICAL INTENSIVE CARE. <i>Medical Care</i> 1982; 20 :165-79.	71
CHANG RWS, JACOBS S, LEE B. PREDICTING OUTCOME AMONG INTENSIVE CARE UNIT PATIENTS USING COMPUTERIZED TREND ANALYSIS OF DAILY APACHE-II SCORES CORRECTED FOR ORGAN SYSTEM FAILURE. <i>Intensive Care Medicine</i> 1988; 14 :558-66.	71
BAKER JL, KELEN GD, SIVERTSON KT, QUINN TC. UNSUSPECTED HUMAN-IMMUNODEFICIENCY VIRUS IN CRITICALLY ILL EMERGENCY PATIENTS. <i>Journal of the American Medical Association</i> 1987; 257 :2609-11.	71
TAYLOR AE, JOHNSON DC, KAZEMI H. ENVIRONMENTAL TOBACCO SMOKE AND CARDIOVASCULAR DISEASE - A POSITION PAPER FROM THE COUNCIL ON CARDIOPULMONARY AND CRITICAL CARE, AMERICAN HEART ASSOCIATION. <i>Circulation</i> 1992; 86 :699-702.	70
SPIEGEL DM, ULLIAN ME, ZERBE GO, BERL T. DETERMINANTS OF SURVIVAL AND RECOVERY IN ACUTE RENAL FAILURE PATIENTS DIALYZED IN INTENSIVE CARE UNITS. <i>American Journal of Nephrology</i> 1991; 11 :44-7.	70
SHOEMAKER WC, APPEL PL, KRAM HB, DUARTE D, HARRIER HD, OCAMPO HA. COMPARISON OF HEMODYNAMIC AND OXYGEN-TRANSPORT EFFECTS OF DOPAMINE AND DOBUTAMINE IN CRITICALLY ILL SURGICAL PATIENTS. <i>Chest</i> 1989; 96 :120-6.	70

PRESTON GA, LARSON EL, STAMM WE. THE EFFECT OF PRIVATE ISOLATION ROOMS ON PATIENT CARE PRACTICES, COLONIZATION AND INFECTION IN AN INTENSIVE CARE UNIT. <i>American Journal of Medicine</i> 1981; 70 :641-5.	70
GROEGER JS, GUNTUPALLI KK, STROSBURG M, HALPERN N, RAPHAELY RC, CERRA F <i>et al.</i> DESCRIPTIVE ANALYSIS OF CRITICAL CARE UNITS IN THE UNITED STATES - PATIENT CHARACTERISTICS AND INTENSIVE CARE UNIT UTILIZATION. <i>Critical Care Medicine</i> 1993; 21 :279-91.	70
CERRA FB, MADDAUS MA, DUNN DL, WELLS CL, KONSTANTINIDES NN, LEHMANN SL <i>et al.</i> SELECTIVE GUT DECONTAMINATION REDUCES NOSOCOMIAL INFECTIONS AND LENGTH OF STAY BUT NOT MORTALITY OR ORGAN FAILURE IN SURGICAL INTENSIVE CARE UNIT PATIENTS. <i>Archives of Surgery</i> 1992; 127 :163-7.	70
BOYNTON BR, MANNINO FL, DAVIS RF, KOPOTIC RJ, FRIEDERICHSEN G. COMBINED HIGH-FREQUENCY OSCILLATORY VENTILATION AND INTERMITTENT MANDATORY VENTILATION IN CRITICALLY ILL NEONATES. <i>Journal of Pediatrics</i> 1984; 105 :297-302.	70
WILKINS RG, FARAGHER EB. ACUTE RENAL FAILURE IN AN INTENSIVE CARE UNIT - INCIDENCE, PREDICTION AND OUTCOME. <i>Anaesthesia</i> 1983; 38 :628-34.	69
WALKER DJB, FELDMAN A, VOHR BR, OH W. COST-BENEFIT ANALYSIS OF NEONATAL INTENSIVE CARE FOR INFANTS WEIGHING LESS THAN 1000 GRAMS AT BIRTH. <i>Pediatrics</i> 1984; 74 :20-5.	69
VERMES I, BEISHUIZEN A, HAMSINK RM, HAANEN C. DISSOCIATION OF PLASMA ADRENOCORTICOTROPIN AND CORTISOL LEVELS IN CRITICALLY ILL PATIENTS - POSSIBLE ROLE OF ENDOTHELIN AND ATRIAL NATRIURETIC HORMONE. <i>Journal of Clinical Endocrinology and Metabolism</i> 1995; 80 :1238-42.	69
HAWKER FH, STEWART PM, BAXTER RC, BORKMANN M, TAN K, CATERSON ID <i>et al.</i> RELATIONSHIP OF SOMATOMEDIN-C/INSULIN-LIKE GROWTH FACTOR-I LEVELS TO CONVENTIONAL NUTRITIONAL INDEXES IN CRITICALLY ILL PATIENTS. <i>Critical Care Medicine</i> 1987; 15 :732-6.	69
VINCENT JL. EUROPEAN ATTITUDES TOWARDS ETHICAL PROBLEMS IN INTENSIVE CARE MEDICINE - RESULTS OF AN ETHICAL QUESTIONNAIRE. <i>Intensive Care Medicine</i> 1990; 16 :256-64.	68
STOUTENBEEK CP, VANSANE HKF, ZANDSTRA DF. THE EFFECT OF ORAL NONABSORBABLE ANTIBIOTICS ON THE EMERGENCE OF RESISTANT BACTERIA IN PATIENTS IN AN INTENSIVE CARE UNIT. <i>Journal of Antimicrobial Chemotherapy</i> 1987; 19 :513-20.	68
SPENCER RC. PREDOMINANT PATHOGENS FOUND IN THE EUROPEAN PREVALENCE OF INFECTION IN INTENSIVE CARE STUDY. <i>European Journal of Clinical Microbiology & Infectious Diseases</i> 1996; 15 :281-5.	68
PINILLA JC, OLENIUK FH, REED D, MALIK B, LAVERTY WH. DOES ANTACID PROPHYLAXIS PREVENT UPPER GASTROINTESTINAL BLEEDING IN CRITICALLY ILL PATIENTS. <i>Critical Care Medicine</i> 1985; 13 :646-50.	68
KOLLEF MH, SHERMAN G, WARD S, FRASER VJ. INADEQUATE ANTIMICROBIAL TREATMENT OF INFECTIONS - A RISK FACTOR FOR HOSPITAL MORTALITY AMONG CRITICALLY ILL PATIENTS. <i>Chest</i> 1999; 115 :462-74.	68
GARVEY BM, MCCAMBLEY JA, TUXEN DV. EFFECTS OF GASTRIC ALKALIZATION ON BACTERIAL COLONIZATION IN CRITICALLY ILL PATIENTS. <i>Critical Care Medicine</i> 1989; 17 :211-6.	68
CULLEN DJ, KEENE R, WATERNAUX C, KUNSMAN JM, CALDERA DL, PETERSON H. RESULTS, CHARGES, AND BENEFITS OF INTENSIVE CARE FOR CRITICALLY ILL PATIENTS - UPDATE 1983. <i>Critical Care Medicine</i> 1984; 12 :102-6.	68
CHERNOW B, ZALOGA G, MCFADDEN E, CLAPPER M, KOTLER M, BARTON M <i>et al.</i> HYPOCALCEMIA IN CRITICALLY ILL PATIENTS. <i>Critical Care Medicine</i> 1982; 10 :848-51.	68
CHERNOW B, BAMBERGER S, STOIKO M, VADNAIS M, MILLS S, HOELLERICH V <i>et al.</i> HYPOMAGNESEMIA IN PATIENTS IN POSTOPERATIVE INTENSIVE CARE. <i>Chest</i> 1989; 95 :391-7.	68
CHELLURI L, PINSKY MR, DONAHOE MP, GRENVIK A. LONG-TERM OUTCOME OF CRITICALLY ILL ELDERLY PATIENTS REQUIRING INTENSIVE CARE. <i>Journal of the American Medical Association</i> 1993; 269 :3119-23.	68
BORRERO E, BANK S, MARGOLIS I, SCHULMAN ND, CHARDAVOYNE R. COMPARISON OF ANTACID AND SUCRALFATE IN THE PREVENTION OF GASTROINTESTINAL BLEEDING IN PATIENTS WHO ARE CRITICALLY ILL. <i>American Journal of Medicine</i> 1985; 79 :62-4.	68

WEISSMAN C, KEMPER M, ELWYN DH, ASKANAZI J, HYMAN AI, KINNEY JM. THE ENERGY EXPENDITURE OF THE MECHANICALLY VENTILATED CRITICALLY ILL PATIENT - AN ANALYSIS. <i>Chest</i> 1986; 89 :254-9.	67
ROSENBLUM LS, VILLARINO ME, NAINAN OV, MELISH ME, HADLER SC, PINSKY PP <i>et al.</i> HEPATITIS-A OUTBREAK IN A NEONATAL INTENSIVE CARE UNIT - RISK FACTORS FOR TRANSMISSION AND EVIDENCE OF PROLONGED VIRAL EXCRETION AMONG PRETERM INFANTS. <i>Journal of Infectious Diseases</i> 1991; 164 :476-82.	67
ORTQVIST A, STERNER G, NILSSON JA. SEVERE COMMUNITY-ACQUIRED PNEUMONIA - FACTORS INFLUENCING NEED OF INTENSIVE CARE TREATMENT AND PROGNOSIS. <i>Scandinavian Journal of Infectious Diseases</i> 1985; 17 :377-86.	67
LYRENE RK, TRUOG WE. ADULT RESPIRATORY DISTRESS SYNDROME IN A PEDIATRIC INTENSIVE CARE UNIT - PREDISPOSING CONDITIONS, CLINICAL COURSE, AND OUTCOME. <i>Pediatrics</i> 1981; 67 :790-5.	67
FREEMAN J, EPSTEIN MF, SMITH NE, PLATT R, SIDEBOTTOM DG, GOLDMANN DA. EXTRA HOSPITAL STAY AND ANTIBIOTIC USAGE WITH NOSOCOMIAL COAGULASE-NEGATIVE STAPHYLOCOCCAL BACTEREMIA IN 2 NEONATAL INTENSIVE CARE UNIT POPULATIONS. <i>American Journal of Diseases of Children</i> 1990; 144 :324-9.	67
DIETRICH KA, CONRAD SA, HEBERT CA, LEVY GL, ROMERO MD. CARDIOVASCULAR AND METABOLIC RESPONSE TO RED BLOOD CELL TRANSFUSION IN CRITICALLY ILL VOLUME-RESUSCITATED NON-SURGICAL PATIENTS. <i>Critical Care Medicine</i> 1990; 18 :940-4.	67
CONLY JM, HILL S, ROSS J, LERTZMAN J, LOUIE TJ. HANDWASHING PRACTICES IN AN INTENSIVE CARE UNIT - THE EFFECTS OF AN EDUCATIONAL PROGRAM AND ITS RELATIONSHIP TO INFECTION RATES. <i>American Journal of Infection Control</i> 1989; 17 :330-9.	67
BION JF, EDLIN SA, RAMSAY G, MCCABE S, LEDINGHAM IM. VALIDATION OF A PROGNOSTIC SCORE IN CRITICALLY ILL PATIENTS UNDERGOING TRANSPORT. <i>British Medical Journal</i> 1985; 291 :432-4.	67
YEH TS, POLLACK MM, RUTTIMAN UE, HOLBROOK PR, FIELDS AI. VALIDATION OF A PHYSIOLOGIC STABILITY INDEX FOR USE IN CRITICALLY ILL INFANTS AND CHILDREN. <i>Pediatric Research</i> 1984; 18 :445-51.	66
WADE CE, LINDBERG JS, COCKRELL JL, LAMIELL JM, HUNT MM, DUCEY J <i>et al.</i> UPON-ADMISSION ADRENAL STEROIDOGENESIS IS ADAPTED TO THE DEGREE OF ILLNESS IN INTENSIVE CARE UNIT PATIENTS. <i>Journal of Clinical Endocrinology and Metabolism</i> 1988; 67 :223-7.	66
KRESS JP, POHLMAN AS, O'CONNOR MF, HALL JB. DAILY INTERRUPTION OF SEDATIVE INFUSIONS IN CRITICALLY ILL PATIENTS UNDERGOING MECHANICAL VENTILATION. <i>New England Journal of Medicine</i> 2000; 342 :1471-7.	66
GORE SM, CABLE DJ, HOLLAND AJ. ORGAN DONATION FROM INTENSIVE CARE UNITS IN ENGLAND AND WALES - 2 YEAR CONFIDENTIAL AUDIT OF DEATHS IN INTENSIVE CARE. <i>British Medical Journal</i> 1992; 304 :349-55.	66
DUNKLE LM, NAQVI SH, MCCALLUM R, LOFGREN JP. ERADICATION OF EPIDEMIC METHICILLIN-GEN-TAMICIN-RESISTANT STAPHYLOCOCCUS AUREUS IN AN INTENSIVE CARE NURSERY. <i>American Journal of Medicine</i> 1981; 70 :455-8.	66
BRUNNER G, CHANG J. INTRAVENOUS THERAPY WITH HIGH DOSES OF RANITIDINE AND OMEPRAZOLE IN CRITICALLY ILL PATIENTS WITH BLEEDING PEPTIC ULCERATIONS OF THE UPPER INTESTINAL TRACT - AN OPEN RANDOMIZED CONTROLLED TRIAL. <i>Digestion</i> 1990; 45 :217-25.	66
BRAMAN SS, DUNN SM, AMICO CA, MILLMAN RP. COMPLICATIONS OF INTRAHOSPITAL TRANSPORT IN CRITICALLY ILL PATIENTS. <i>Annals of Internal Medicine</i> 1987; 107 :469-73.	66
ATKINSON S, SIEFFERT E, BIHARI D. A PROSPECTIVE, RANDOMIZED, DOUBLE-BLIND, CONTROLLED CLINICAL TRIAL OF ENTERAL IMMUNONUTRITION IN THE CRITICALLY ILL. <i>Critical Care Medicine</i> 1998; 26 :1164-72.	66
WATLING SM, DASTA JF. PROLONGED PARALYSIS IN INTENSIVE CARE UNIT PATIENTS AFTER THE USE OF NEUROMUSCULAR BLOCKING AGENTS - A REVIEW OF THE LITERATURE. <i>Critical Care Medicine</i> 1994; 22 :884-93.	65
TOBIN MJ. RESPIRATORY MONITORING IN THE INTENSIVE CARE UNIT. <i>American Review of Respiratory Disease</i> 1988; 138 :1625-42.	65
BRINSON RR, KOLTS BE. HYPOALBUMINEMIA AS AN INDICATOR OF DIARRHEAL INCIDENCE IN CRITICALLY ILL PATIENTS. <i>Critical Care Medicine</i> 1987; 15 :506-9.	65

AMOS RJ, HINDS CJ, AMESS JAL, MOLLIN DL. INCIDENCE AND PATHOGENESIS OF ACUTE MEGALOBlastic BONE MARROW CHANGE IN PATIENTS RECEIVING INTENSIVE CARE. <i>Lancet</i> 1982; 2 :835-9.	65
ROSS RJM, MIELL JP, HOLLY JMP, MAHESHWARI H, NORMAN M, ABDULLA AF <i>et al</i> . LEVELS OF GH-BINDING ACTIVITY, IGFBP-1, INSULIN, BLOOD GLUCOSE AND CORTISOL IN INTENSIVE CARE PATIENTS. <i>Clinical Endocrinology</i> 1991; 35 :361-7.	64
PATTERSON JE, VECCHIO J, PANTELICK EL, FARREL P, MAZON D, ZERVOS MJ <i>et al</i> . ASSOCIATION OF CONTAMINATED GLOVES WITH TRANSMISSION OF ACINETOBACTER CALCOACETICUS VAR ANITRATUS IN AN INTENSIVE CARE UNIT. <i>American Journal of Medicine</i> 1991; 91 :479-83.	64
LUCE JM. INTRODUCTION OF NEW TECHNOLOGY INTO CRITICAL CARE PRACTICE - A HISTORY OF HA-1A HUMAN MONOCLONAL ANTIBODY AGAINST ENDOTOXIN. <i>Critical Care Medicine</i> 1993; 21 :1233-41.	64
KERVER AJH, ROMMES JH, MEVISSENVERHAGE EAE, HULSTAERT PF, VOS A, VERHOEF J <i>et al</i> . COLONIZATION AND INFECTION IN SURGICAL INTENSIVE CARE PATIENTS - A PROSPECTIVE STUDY. <i>Intensive Care Medicine</i> 1987; 13 :347-51.	64
GREENBAUM DM, MARSCHALL KE. THE VALUE OF ROUTINE DAILY CHEST X-RAYS IN INTUBATED PATIENTS IN THE MEDICAL INTENSIVE CARE UNIT. <i>Critical Care Medicine</i> 1982; 10 :29-30.	64
SIDEBOTTOM DG, FREEMAN J, PLATT R, EPSTEIN MF, GOLDMANN DA. 15-YEAR EXPERIENCE WITH BLOODSTREAM ISOLATES OF COAGULASE- NEGATIVE STAPHYLOCOCCI IN NEONATAL INTENSIVE CARE. <i>Journal of Clinical Microbiology</i> 1988; 26 :713-8.	63
SHOEMAKER WC, BLAND RD, APPEL PL. THERAPY OF CRITICALLY ILL POSTOPERATIVE PATIENTS BASED ON OUTCOME PREDICTION AND PROSPECTIVE CLINICAL TRIALS. <i>Surgical Clinics of North America</i> 1985; 65 :811-33.	63
ROUBY JJ, LHERM T, DELASSALE EM, POETE P, BODIN L, FINET JF <i>et al</i> . HISTOLOGIC ASPECTS OF PULMONARY BAROTRAUMA IN CRITICALLY ILL PATIENTS WITH ACUTE RESPIRATORY FAILURE. <i>Intensive Care Medicine</i> 1993; 19 :383-9.	63
HEYLAND DK, MACDONALD S, KEEFE L, DROVER JW. TOTAL PARENTERAL NUTRITION IN THE CRITICALLY ILL PATIENT. <i>Journal of the American Medical Association</i> 1998; 280 :2013-9.	63
FRIEDMAN Y. BEDSIDE PERCUTANEOUS TRACHEOSTOMY IN CRITICALLY ILL PATIENTS. <i>Chest</i> 1993; 104 :532-5.	63
SOUTHALL DP, BIGNALL S, STEBBENS VA, ALEXANDER JR, RIVERS RPA, LISSAUER T. PULSE OXIMETER AND TRANSCUTANEOUS ARTERIAL OXYGEN MEASUREMENTS IN NEONATAL AND PEDIATRIC INTENSIVE CARE. <i>Archives of Disease in Childhood</i> 1987; 62 :882-8.	62
PARTRIDGE BL, ABRAMS JH, BAZEMORE C, RUBIN R. PROLONGED NEUROMUSCULAR BLOCKADE AFTER LONG-TERM INFUSION OF VECURONIUM BROMIDE IN THE INTENSIVE CARE UNIT. <i>Critical Care Medicine</i> 1990; 18 :1177-9.	62
MODI N, DAMJANOVIC V, COOKE RWI. OUTBREAK OF CEPHALOSPORIN-RESISTANT ENTEROBATER CLOACAE INFECTION IN A NEONATAL INTENSIVE CARE UNIT. <i>Archives of Disease in Childhood</i> 1987; 62 :148-51.	62
MCCLISH DK, POWELL SH. HOW WELL CAN PHYSICIANS ESTIMATE MORTALITY IN A MEDICAL INTENSIVE CARE UNIT. <i>Medical Decision Making</i> 1989; 9 :125-32.	62
HEFFNER JE, MILLER KS, SAHN SA. TRACHEOSTOMY IN THE INTENSIVE CARE UNIT: INDICATIONS, TECHNIQUE, MANAGEMENT. <i>Chest</i> 1986; 90 :269-74.	62
HARRIS MC, COSTARINO AT, SULLIVAN JS, DULKERIAN S, MCCAWLEY L, CORCORAN L <i>et al</i> . CYTOKINE ELEVATIONS IN CRITICALLY ILL INFANTS WITH SEPSIS AND NECROTIZING ENTEROCOLITIS. <i>Journal of Pediatrics</i> 1994; 124 :105-11.	62
CERRA FB, MAZUSKI J, TEASLEY K, NUWER N, LYSNE J, SHRONT S <i>et al</i> . NITROGEN-RETENTION IN CRITICALLY ILL PATIENTS IS PROPORTIONAL TO THE BRANCHED CHAIN AMINO ACID LOAD. <i>Critical Care Medicine</i> 1983; 11 :775-8.	62
BENMENACHEM T, FOGEL R, PATEL RV, TOUCHETTE M, ZAROWITZ BJ, HADZIJAHIC N <i>et al</i> . PROPHYLAXIS FOR STRESS-RELATED GASTRIC HEMORRHAGE IN THE MEDICAL INTENSIVE CARE UNIT - A RANDOMIZED, CONTROLLED, SINGLE- BLIND STUDY. <i>Annals of Internal Medicine</i> 1994; 121 :568-9.	62

POLLACK MM, GETSON PR, RUTTIMANN UE, STEINHART CM, KANTER RK, KATZ RW <i>et al.</i> EFFICIENCY OF INTENSIVE CARE - A COMPARATIVE ANALYSIS OF 8 PEDIATRIC INTENSIVE CARE UNITS. <i>Journal of the American Medical Association</i> 1987; 258 :1481-6.	61
LANGER M, CIGADA M, MANDELLI M, MOSCONI P, TOGNONI G. EARLY ONSET PNEUMONIA - A MULTI-CENTER STUDY IN INTENSIVE CARE UNITS. <i>Intensive Care Medicine</i> 1987; 13 :342-6.	61
HELLGREN M, EGBERG N, EKLUND J. BLOOD COAGULATION AND FIBRINOLYTIC FACTORS AND THEIR INHIBITORS IN CRITICALLY ILL PATIENTS. <i>Intensive Care Medicine</i> 1984; 10 :23-8.	61
BENNER P, TANNER C, CHESLA C. FROM BEGINNER TO EXPERT - GAINING A DIFFERENTIATED CLINICAL WORLD IN CRITICAL CARE NURSING. <i>Advances in Nursing Science</i> 1992; 14 :13-28.	61
ZALOGA GP, CHERNOW B, COOK D, SNYDER R, CLAPPER M, OBRIAN JT. ASSESSMENT OF CALCIUM HOMEOSTASIS IN THE CRITICALLY ILL SURGICAL PATIENT - THE DIAGNOSTIC PITFALLS OF THE MCLEAN- HASTINGS NOMOGRAM. <i>Annals of Surgery</i> 1985; 202 :587-94.	60
TAKEDA K, SHIMADA Y, AMANO M, SAKAI T, OKADA T, YOSHIYA I. PLASMA-LIPID PEROXIDES AND ALPHA-TOCOPHEROL IN CRITICALLY ILL PATIENTS. <i>Critical Care Medicine</i> 1984; 12 :957-9.	60
STROHMAIER W, REDL H, SCHLAG G, INTHORN D. D-ERYTHRO-NEOPTERIN PLASMA LEVELS IN INTENSIVE CARE PATIENTS WITH AND WITHOUT SEPTIC COMPLICATIONS. <i>Critical Care Medicine</i> 1987; 15 :757-60.	60
SHOEMAKER WC, APPEL PL, KRAM HB. HEMODYNAMIC AND OXYGEN TRANSPORT EFFECTS OF DOBUTAMINE IN CRITICALLY ILL GENERAL SURGICAL PATIENTS. <i>Critical Care Medicine</i> 1986; 14 :1032-7.	60
RUSSELL JA, PHANG PT. THE OXYGEN DELIVERY CONSUMPTION CONTROVERSY - APPROACHES TO MANAGEMENT OF THE CRITICALLY ILL. <i>American Journal of Respiratory and Critical Care Medicine</i> 1994; 149 :533-7.	60
OLDENHOF H, DEJONG M, STEENHOEK A, JANKNEGT R. CLINICAL PHARMACOKINETICS OF MID-AZOLAM IN INTENSIVE CARE PATIENTS, A WIDE INTERPATIENT VARIABILITY. <i>Clinical Pharmacology & Therapeutics</i> 1988; 43 :263-9.	60
LUCET JC, CHEVRET S, DECRE D, VANJAK D, MACREZ A, BEDOS JP <i>et al.</i> OUTBREAK OF MULTIPLY- RESISTANT ENTEROBACTERIACEAE IN AN INTENSIVE CARE UNIT: EPIDEMIOLOGY AND RISK FACTORS FOR ACQUISITION. <i>Clinical Infectious Diseases</i> 1996; 22 :430-6.	60
GRUM CM, SIMON RH, DANTZKER DR, FOX IH. EVIDENCE FOR ADENOSINE TRIPHOSPHATE DEGRADATION IN CRITICALLY ILL PATIENTS. <i>Chest</i> 1985; 88 :763-7.	60
CAMERON JS. ACUTE RENAL FAILURE IN THE INTENSIVE CARE UNIT TODAY. <i>Intensive Care Medicine</i> 1986; 12 :64-70.	60
BUTLER PW, BONE RC, FIELD T. TECHNOLOGY UNDER MEDICARE DIAGNOSIS-RELATED GROUPS PROSPECTIVE PAYMENT - IMPLICATIONS FOR MEDICAL INTENSIVE CARE. <i>Chest</i> 1985; 87 :229-34.	60
BLAIR P, ROWLANDS BJ, LOWRY K, WEBB H, ARMSTRONG P, SMILIE J. SELECTIVE DECONTAMINATION OF THE DIGESTIVE TRACT - A STRATIFIED, RANDOMIZED, PROSPECTIVE-STUDY IN A MIXED INTENSIVE CARE UNIT. <i>Surgery</i> 1991; 110 :303-10.	60
BARRIENTOSVEGA R, SANCHEZSORIA MM, MORALESGARCIA C, ROBASGOMEZ A, CUENABOY R, AY-ENSARINCON A. PROLONGED SEDATION OF CRITICALLY ILL PATIENTS WITH MIDAZOLAM OR PROPOFOL: IMPACT ON WEANING AND COSTS. <i>Critical Care Medicine</i> 1997; 25 :33-40.	60
SLAG MF, MORLEY JE, ELSON MK, LABROSSE KR, CROWSON TW, NUTTALL FQ <i>et al.</i> FREE-THYROXINE LEVELS IN CRITICALLY ILL PATIENTS - A COMPARISON OF CURRENTLY AVAILABLE ASSAYS. <i>Journal of the American Medical Association</i> 1981; 246 :2702-6.	59
SCHWARTZ DE, MATTHAY MA, COHEN NH. DEATH AND OTHER COMPLICATIONS OF EMERGENCY AIRWAY MANAGEMENT IN CRITICALLY ILL ADULTS - A PROSPECTIVE INVESTIGATION OF 297 TRACHEAL INTUBATIONS. <i>Anesthesiology</i> 1995; 82 :367-76.	59
POSES RM, BEKES C, COPARE FJ, SCOTT WE. THE ANSWER TO WHAT ARE MY CHANCES, DOCTOR DEPENDS ON WHOM IS ASKED - PROGNOSTIC DISAGREEMENT AND INACCURACY FOR CRITICALLY ILL PATIENTS. <i>Critical Care Medicine</i> 1989; 17 :827-36.	59
PIATT JH, SCHIFF SJ. HIGH-DOSE BARBITURATE THERAPY IN NEUROSURGERY AND INTENSIVE CARE. <i>Neurosurgery</i> 1984; 15 :427-44.	59
MCCARTHY JT. PROGNOSIS OF PATIENTS WITH ACUTE RENAL FAILURE IN THE INTENSIVE CARE UNIT: A TALE OF TWO ERAS. <i>Mayo Clinic Proceedings</i> 1996; 71 :117-26.	59

GIL RT, KRUSE JA, THILLBAHAROZIAN MC, CARLSON RW. TRIPLE-LUMEN VS SINGLE-LUMEN CENTRAL VENOUS CATHETERS - A PROSPECTIVE STUDY IN A CRITICALLY ILL POPULATION. <i>Archives of Internal Medicine</i> 1989; 149 :1139-43.	59
FELDMAN C, KALLENBACH JM, LEVY H, REINACH SG, HURWITZ MD, THORBURN JR <i>et al.</i> COMMUNITY-ACQUIRED PNEUMONIA OF DIVERSE ETIOLOGY - PROGNOSTIC FEATURES IN PATIENTS ADMITTED TO AN INTENSIVE CARE UNIT AND A SEVERITY OF ILLNESS SCORE. <i>Intensive Care Medicine</i> 1989; 15 :302-7.	59
EISENBERG PR, HANSBROUGH JR, ANDERSON D, SCHUSTER DP. A PROSPECTIVE STUDY OF LUNG WATER MEASUREMENTS DURING PATIENT MANAGEMENT IN AN INTENSIVE CARE UNIT. <i>American Review of Respiratory Disease</i> 1987; 136 :662-8.	59
CHIESA C, PANERO A, ROSSI N, STEGAGNO M, DE GIUSTI M, OSBORN JF <i>et al.</i> RELIABILITY OF PROCALCITONIN CONCENTRATIONS FOR THE DIAGNOSIS OF SEPSIS IN CRITICALLY ILL NEONATES. <i>Clinical Infectious Diseases</i> 1998; 26 :664-72.	59
BIROS MH, LEWIS RJ, OLSON CM, RUNGE JW, CUMMINS RO, FOST N. INFORMED CONSENT IN EMERGENCY RESEARCH - CONSENSUS STATEMENT FROM THE COALITION CONFERENCE OF ACUTE RESUSCITATION AND CRITICAL CARE RESEARCHERS. <i>Journal of the American Medical Association</i> 1995; 273 :1283-7.	59
AMBUEL B, HAMLETT KW, MARX CM, BLUMER JL. ASSESSING DISTRESS IN PEDIATRIC INTENSIVE CARE ENVIRONMENTS - THE COMFORT SCALE. <i>Journal of Pediatric Psychology</i> 1992; 17 :95-109.	59
WESTABY S, PILLAI R, PARRY A, OREGAN D, GIANNOPOULOS N, GREBENIK K <i>et al.</i> DOES MODERN CARDIAC SURGERY REQUIRE CONVENTIONAL INTENSIVE CARE. <i>European Journal of Cardio-Thoracic Surgery</i> 1993; 7 :313-8.	58
SIBBALD WJ, WARSHAWSKI FJ, SHORT AK, HARRIS J, LEFCOE MS, HOLLIDAY RL. CLINICAL STUDIES OF MEASURING EXTRA VASCULAR LUNG WATER BY THE THERMAL DYE TECHNIQUE IN CRITICALLY ILL PATIENTS. <i>Chest</i> 1983; 83 :725-31.	58
MICHEL L, MARSH HM, MCMICHAN JC, SOUTHORN PA, BREWER NS. INFECTION OF PULMONARY ARTERY CATHETERS IN CRITICALLY ILL PATIENTS. <i>Journal of the American Medical Association</i> 1981; 245 :1032-6.	58
MAKI DG. RISK FACTORS FOR NOSOCOMIAL INFECTION IN INTENSIVE CARE - DEVICES VS NATURE AND GOALS FOR THE NEXT DECADE. <i>Archives of Internal Medicine</i> 1989; 149 :30-5.	58
LEMESHOW S, TERES D, AVRUNIN JS, PASTIDES H. A COMPARISON OF METHODS TO PREDICT MORTALITY OF INTENSIVE CARE UNIT PATIENTS. <i>Critical Care Medicine</i> 1987; 15 :715-22.	58
KALB PE, MILLER DH. UTILIZATION STRATEGIES FOR INTENSIVE CARE UNITS. <i>Journal of the American Medical Association</i> 1989; 261 :2389-95.	58
FOLEY EF, BORLASE BC, DZIK WH, BISTRAN BR, BENOTTI PN. ALBUMIN SUPPLEMENTATION IN THE CRITICALLY ILL - A PROSPECTIVE, RANDOMIZED TRIAL. <i>Archives of Surgery</i> 1990; 125 :739-42.	58
FAIX RG, KOVARIK SM, SHAW TR, JOHNSON RV. MUCOCUTANEOUS AND INVASIVE CANDIDIASIS AMONG VERY-LOW-BIRTH- WEIGHT (LESS-THAN-1500 GRAMS) INFANTS IN INTENSIVE CARE NURSERIES - A PROSPECTIVE-STUDY. <i>Pediatrics</i> 1989; 83 :101-7.	58
COHEN IL, WEINBERG PF, FEIN IA, ROWINSKI GS. ENDOTRACHEAL TUBE OCCLUSION ASSOCIATED WITH THE USE OF HEAT AND MOISTURE EXCHANGERS IN THE INTENSIVE CARE UNIT. <i>Critical Care Medicine</i> 1988; 16 :277-9.	58
COHEN IL, LAMBRINOS J, FEIN IA. MECHANICAL VENTILATION FOR THE ELDERLY PATIENT IN INTENSIVE CARE - INCREMENTAL CHARGES AND BENEFITS. <i>Journal of the American Medical Association</i> 1993; 269 :1025-9.	58
ZALOGA GP. BEDSIDE METHOD FOR PLACING SMALL BOWEL FEEDING TUBES IN CRITICALLY ILL PATIENTS - A PROSPECTIVE-STUDY. <i>Chest</i> 1991; 100 :1643-6.	57
VERVLOET MG, THIJS LG, HACK CE. DERANGEMENTS OF COAGULATION AND FIBRINOLYSIS IN CRITICALLY ILL PATIENTS WITH SEPSIS AND SEPTIC SHOCK. <i>Seminars in Thrombosis and Hemostasis</i> 1998; 24 :33-44.	57
SIMMONS B, BRYANT J, NEIMAN K, SPENCER L, ARHEART K. THE ROLE OF HANDWASHING IN PREVENTION OF ENDEMIC INTENSIVE CARE UNIT INFECTIONS. <i>Infection Control and Hospital Epidemiology</i> 1990; 11 :589-94.	57
MIRVIS SE, TOBIN KD, KOSTRUBIAK I, BELZBERG H. THORACIC CT IN DETECTING OCCULT DISEASE IN CRITICALLY ILL PATIENTS. <i>American Journal of Roentgenology</i> 1987; 148 :685-9.	57

LACOMIS D, GIULIANI MJ, VANCOTT A, KRAMER DJ. ACUTE MYOPATHY OF INTENSIVE CARE: CLINICAL, ELECTROMYOGRAPHIC, AND PATHOLOGICAL ASPECTS. <i>Annals of Neurology</i> 1996; 40 :645-54.	57
KIMBLE KJ, DARNALL RA, YELDERMAN M, ARIAGNO RL, REAM AK. AN AUTOMATED OSCILLOMETRIC TECHNIQUE FOR ESTIMATING MEAN ARTERIAL PRESSURE IN CRITICALLY ILL NEWBORNS. <i>Anesthesiology</i> 1981; 54 :423-5.	57
JAYES RL, ZIMMERMAN JE, WAGNER DP, DRAPER EA, KNAUS WA. DO-NOT-RESUSCITATE ORDERS IN INTENSIVE CARE UNITS - CURRENT PRACTICES AND RECENT CHANGES. <i>Journal of the American Medical Association</i> 1993; 270 :2213-7.	57
DESAI TK, CARLSON RW, GEHEB MA. PREVALENCE AND CLINICAL IMPLICATIONS OF HYPOCALCEMIA IN ACUTELY ILL PATIENTS IN A MEDICAL INTENSIVE CARE SETTING. <i>American Journal of Medicine</i> 1988; 84 :209-14.	57
CAMPBELL AGM. WHICH INFANTS SHOULD NOT RECEIVE INTENSIVE CARE. <i>Archives of Disease in Childhood</i> 1982; 57 :569-71.	57
BONNET F, RICHARD C, GLASER P, LAFAY M, GUESDE R. CHANGES IN HEPATIC FLOW INDUCED BY CONTINUOUS POSITIVE PRESSURE VENTILATION IN CRITICALLY ILL PATIENTS. <i>Critical Care Medicine</i> 1982; 10 :703-5.	57
SMITH RL, MEIXLER SM, SIMBERKOFF MS. EXCESS MORTALITY IN CRITICALLY ILL PATIENTS WITH NOSOCOMIAL BLOOD STREAM INFECTIONS. <i>Chest</i> 1991; 100 :164-7.	56
SIMMS HH, DEMARIA E, MCDONALD L, PETERSON D, ROBINSON A, BURCHARD KW. ROLE OF GASTRIC COLONIZATION IN THE DEVELOPMENT OF PNEUMONIA IN CRITICALLY ILL TRAUMA PATIENTS - RESULTS OF A PROSPECTIVE RANDOMIZED TRIAL. <i>Journal of Trauma-Injury Infection and Critical Care</i> 1991; 31 :531-7.	56
SCHENTAG JJ, CERRA FB, PLAUT ME. CLINICAL AND PHARMACOKINETIC CHARACTERISTICS OF AMINOGLYCOSIDE NEPHROTOXICITY IN 201 CRITICALLY ILL PATIENTS. <i>Antimicrobial Agents and Chemotherapy</i> 1982; 21 :721-6.	56
RODRIGUEZ JL, WEISSMAN C, DAMASK MC, ASKANAZI J, HYMAN AI, KINNEY JM. MORPHINE AND POSTOPERATIVE REWARMING IN CRITICALLY ILL PATIENTS. <i>Circulation</i> 1983; 68 :1238-46.	56
PREVOST G, POTTECHER B, DAHLET M, BIENTZ M, MANTZ JM, PIEMONT Y. PULSED FIELD GELELECTROPHORESIS AS A NEW EPIDEMIOLOGIC TOOL FOR MONITORING METHICILLIN-RESISTANT STAPHYLOCOCCUS AUREUS IN AN INTENSIVE CARE UNIT. <i>Journal of Hospital Infection</i> 1991; 17 :255-69.	56
MANN HJ, FUHS DW, AWANG R, NDEMO FA, CERRA FB. ALTERED AMINOGLYCOSIDE PHARMACOKINETICS IN CRITICALLY ILL PATIENTS WITH SEPSIS. <i>Clinical Pharmacy</i> 1987; 6 :148-53.	56
LACROIX J, INFANTERIVARD C, JENICEK M, GAUTHIER M. PROPHYLAXIS OF UPPER GASTROINTESTINAL BLEEDING IN INTENSIVE CARE UNITS - A META-ANALYSIS. <i>Critical Care Medicine</i> 1989; 17 :862-9.	56
KRAMER P, BOHLER J, KEHR A, GRONE HJ, SCHRADER J, MATTHAEI D <i>et al.</i> INTENSIVE CARE POTENTIAL OF CONTINUOUS ARTERIOVENOUS HEMOFILTRATION. <i>Transactions American Society for Artificial Internal Organs</i> 1982; 28 :28-32.	56
DASCHNER F. NOSOCOMIAL INFECTIONS IN INTENSIVE CARE UNITS. <i>Intensive Care Medicine</i> 1985; 11 :284-7.	56
COOK DJ, WALTER SD, COOK RJ, GRIFFITH LE, GUYATT GH, LEASA D <i>et al.</i> INCIDENCE OF AND RISK FACTORS FOR VENTILATOR-ASSOCIATED PNEUMONIA IN CRITICALLY ILL PATIENTS. <i>Annals of Internal Medicine</i> 1998; 129 :433-40.	56
WEISSMAN C, KEMPER M, ASKANAZI J, HYMAN AI, KINNEY JM. RESTING METABOLIC RATE OF THE CRITICALLY ILL PATIENT - MEASURED VERSUS PREDICTED. <i>Anesthesiology</i> 1986; 64 :673-9.	55
WAGNER DP, KNAUS WA, DRAPER EA, ZIMMERMAN JE. IDENTIFICATION OF LOW-RISK MONITOR PATIENTS WITHIN A MEDICAL- SURGICAL INTENSIVE CARE UNIT. <i>Medical Care</i> 1983; 21 :425-34.	55
VANBOMMEL EFH, BOUVY ND, SO KL, ZIETSE R, VINCENT HH, BRUINING HA <i>et al.</i> ACUTE DIALYTIC SUPPORT FOR THE CRITICALLY ILL - INTERMITTENT HEMODIALYSIS VERSUS CONTINUOUS ARTERIOVENOUS HEMODIAFILTRATION. <i>American Journal of Nephrology</i> 1995; 15 :192-200.	55
SWINAMER DL, PHANG PT, JONES RL, GRACE M, KING EG. 24-HOUR ENERGY EXPENDITURE IN CRITICALLY ILL PATIENTS. <i>Critical Care Medicine</i> 1987; 15 :637-43.	55

SCHIPPER HG, ROOS J, VANDERMEULEN F, TENCATE JW. ANTI-THROMBIN-III DEFICIENCY IN SURGICAL INTENSIVE CARE PATIENTS. <i>Thrombosis Research</i> 1981; 21 :73-80.	55
SCHENTAG JJ, VARI AJ, WINSLADE NE, SWANSON DJ, SMITH IL, SIMONS GW <i>et al.</i> TREATMENT WITH AZTREONAM OR TOBRAMYCIN IN CRITICAL CARE PATIENTS WITH NOSOCOMIAL GRAM-NEGATIVE PNEUMONIA. <i>American Journal of Medicine</i> 1985; 78 :34-41.	55
ROTH A, BARBASH GI, HOD H, MILLER HI, RATH S, MODAN M <i>et al.</i> SHOULD THROMBOLYTIC THERAPY BE ADMINISTERED IN THE MOBILE INTENSIVE CARE UNIT IN PATIENTS WITH EVOLVING MYOCARDIAL INFARCTION - A PILOT STUDY. <i>Journal of the American College of Cardiology</i> 1990; 15 :932-6.	55
GROEGER JS, STROSBERG MA, HALPERN NA, RAPHAELY RC, KAYE WE, GUNTUPALLI KK <i>et al.</i> DESCRIPTIVE ANALYSIS OF CRITICAL CARE UNITS IN THE UNITED STATES. <i>Critical Care Medicine</i> 1992; 20 :846-63.	55
GRAHAM M. FREQUENCY AND DURATION OF HANDWASHING IN AN INTENSIVE CARE UNIT. <i>American Journal of Infection Control</i> 1990; 18 :77-80.	55
ENGELHARDT HT, RIE MA. INTENSIVE CARE UNITS, SCARCE RESOURCES, AND CONFLICTING PRINCIPLES OF JUSTICE. <i>Journal of the American Medical Association</i> 1986; 255 :1159-64.	55
BODENHAM A, DIAMENT R, COHEN A, WEBSTER N. PERCUTANEOUS DILATIONAL TRACHEOSTOMY - A BEDSIDE PROCEDURE ON THE INTENSIVE CARE UNIT. <i>Anaesthesia</i> 1991; 46 :570-2.	55
BEKEMEYER WB, CRAPO RO, CALHOON S, CANNON CY, CLAYTON PD. EFFICACY OF CHEST RADIOGRAPHY IN A RESPIRATORY INTENSIVE CARE UNIT - A PROSPECTIVE STUDY. <i>Chest</i> 1985; 88 :691-6.	55
AURELL J, ELMQVIST D. SLEEP IN THE SURGICAL INTENSIVE CARE UNIT - CONTINUOUS POLYGRAPHIC RECORDING OF SLEEP IN 9 PATIENTS RECEIVING POSTOPERATIVE CARE. <i>British Medical Journal</i> 1985; 290 :1029-32.	55
LEMESHOW S, KLAR J, TERES D, AVRUNIN JS, GEHLBACH SH, RAPOPORT J <i>et al.</i> MORTALITY PROBABILITY MODELS FOR PATIENTS IN THE INTENSIVE CARE UNIT FOR 48 OR 72 HOURS - A PROSPECTIVE, MULTICENTER STUDY. <i>Critical Care Medicine</i> 1994; 22 :1351-8.	54
HUEBNER J, PIER GB, MASLOW JN, MULLER E, SHIRO H, PARENT M <i>et al.</i> ENDEMIC NOSOCOMIAL TRANSMISSION OF STAPHYLOCOCCUS EPIDERMIDIS BACTEREMIA ISOLATES IN A NEONATAL INTENSIVE CARE UNIT OVER 10 YEARS. <i>Journal of Infectious Diseases</i> 1994; 169 :526-31.	54
HADFIELD RJ, SINCLAIR DG, HOULDSWORTH PE, EVANS TW. EFFECTS OF ENTERAL AND PARENTERAL NUTRITION ON GUT MUCOSAL PERMEABILITY IN THE CRITICALLY ILL. <i>American Journal of Respiratory and Critical Care Medicine</i> 1995; 152 :1545-8.	54
GALAMBOS R, HICKS G, WILSON MJ. HEARING LOSS IN GRADUATES OF A TERTIARY INTENSIVE CARE NURSERY. <i>Ear and Hearing</i> 1982; 3 :87-90.	54
FREEMAN J, PLATT R, SIDEBOTTOM DG, LECLAIR JM, EPSTEIN MF, GOLDMANN DA. COAGULASE-NEGATIVE STAPHYLOCOCCAL BACTEREMIA IN THE CHANGING NEONATAL INTENSIVE CARE UNIT POPULATION - IS THERE AN EPIDEMIC. <i>Journal of the American Medical Association</i> 1987; 258 :2548-52.	54
BORST GC, OSBURNE RC, OBRIAN JT, GEORGES LP, BURMAN KD. FASTING DECREASES THYROTROPIN RESPONSIVENESS TO THYROTROPIN RELEASING HORMONE - A POTENTIAL CAUSE OF MISINTERPRETATION OF THYROID FUNCTION TESTS IN THE CRITICALLY ILL. <i>Journal of Clinical Endocrinology and Metabolism</i> 1983; 57 :380-3.	54
BOLTON CF. ELECTROPHYSIOLOGIC STUDIES OF CRITICALLY ILL PATIENTS. <i>Muscle & Nerve</i> 1987; 10 :129-35.	54
YEH TS, POLLACK MM, HOLBROOK PR, FIELDS AI, RUTTINAN U. ASSESSMENT OF PEDIATRIC INTENSIVE CARE - APPLICATION OF THE THERAPEUTIC INTERVENTION SCORING SYSTEM. <i>Critical Care Medicine</i> 1982; 10 :497-500.	53
VAUDRY WL, TIERNEY AJ, WENMAN WM. INVESTIGATION OF A CLUSTER OF SYSTEMIC CANDIDA ALBICANS INFECTIONS IN A NEONATAL INTENSIVE CARE UNIT. <i>Journal of Infectious Diseases</i> 1988; 158 :1375-9.	53
SPRUNG CL, JACOBS LJ, CARALIS PV, KARP M. VENTRICULAR ARRHYTHMIAS DURING SWAN-GANZ CATHETERIZATION OF THE CRITICALLY ILL. <i>Chest</i> 1981; 79 :413-5.	53

SHORTELL SM, ROUSSEAU DM, GILLIES RR, DEVERS KJ, SIMONS TL. ORGANIZATIONAL ASSESSMENT IN INTENSIVE CARE UNITS (ICUS) - CONSTRUCT DEVELOPMENT, RELIABILITY, AND VALIDITY OF THE ICU NURSE-PHYSICIAN QUESTIONNAIRE. <i>Medical Care</i> 1991; 29 :709-26.	53
O'BRIEN MS, RICOTTA JJ. CONSERVING RESOURCES AFTER CAROTID ENDARTERECTOMY - SELECTIVE USE OF THE INTENSIVE CARE UNIT. <i>Journal of Vascular Surgery</i> 1991; 14 :796-802.	53
MARIK PE, LIPMAN J, KOBILSKI S, SCRIBANTE J. A PROSPECTIVE RANDOMIZED STUDY COMPARING ONCE-DAILY VERSUS TWICE-DAILY AMIKACIN DOSING IN CRITICALLY ILL ADULT AND PEDIATRIC PATIENTS. <i>Journal of Antimicrobial Chemotherapy</i> 1991; 28 :753-64.	53
IBERTI TJ, LEIBOWITZ AB, PAPADAKOS PJ, FISCHER EP. LOW SENSITIVITY OF THE ANION GAP AS A SCREEN TO DETECT HYPERLACTATEMIA IN CRITICALLY ILL PATIENTS. <i>Critical Care Medicine</i> 1990; 18 :275-7.	53
HEBERT PC, WELLS G, MARSHALL J, MARTIN C, TWEEDDALE M, PAGLIARELLO G <i>et al.</i> TRANSFUSION REQUIREMENTS IN CRITICAL CARE - A PILOT-STUDY. <i>Journal of the American Medical Association</i> 1995; 273 :1439-44.	53
CHANG RWS, JACOBS S, LEE B. USE OF APACHE-II SEVERITY OF DISEASE CLASSIFICATION TO IDENTIFY INTENSIVE CARE UNIT PATIENTS WHO WOULD NOT BENEFIT FROM TOTAL PARENTERAL NUTRITION. <i>Lancet</i> 1986; 1 :1483-7.	53
WACHTER RM, RUSSI MB, BLOCH DA, HOPEWELL PC, LUCE JM. PNEUMOCYSTIS CARINII PNEUMONIA AND RESPIRATORY FAILURE IN AIDS - IMPROVED OUTCOMES AND INCREASED USE OF INTENSIVE CARE UNITS. <i>American Review of Respiratory Disease</i> 1991; 143 :251-6.	52
VANSAENE HF, STOUTENBEEK CC, STOLLER JK. SELECTIVE DECONTAMINATION OF THE DIGESTIVE TRACT IN THE INTENSIVE CARE UNIT - CURRENT STATUS AND FUTURE PROSPECTS. <i>Critical Care Medicine</i> 1992; 20 :691-703.	52
RIKER RR, FRASER GL, COX PM. CONTINUOUS-INFUSION OF HALOPERIDOL CONTROLS AGITATION IN CRITICALLY ILL PATIENTS. <i>Critical Care Medicine</i> 1994; 22 :433-40.	52
MIMOZ O, RAUSS A, REKIK N, BRUNBUISSON C, LEMAIRE F, BROCHARD L. PULMONARY ARTERY CATHETERIZATION IN CRITICALLY ILL PATIENTS - A PROSPECTIVE ANALYSIS OF OUTCOME CHANGES ASSOCIATED WITH CATHETER-PROMPTED CHANGES IN THERAPY. <i>Critical Care Medicine</i> 1994; 22 :573-9.	52
MEHTA RL. THERAPEUTIC ALTERNATIVES TO RENAL REPLACEMENT FOR CRITICALLY ILL PATIENTS IN ACUTE RENAL FAILURE. <i>Seminars in Nephrology</i> 1994; 14 :64-82.	52
MEHTA RL, MCDONALD BR, AGUILAR MM, WARD DM. REGIONAL CITRATE ANTICOAGULATION FOR CONTINUOUS ARTERIOVENOUS HEMODIALYSIS IN CRITICALLY ILL PATIENTS. <i>Kidney International</i> 1990; 38 :976-81.	52
HELLIWELL TR, COAKLEY JH, WAGENMAKERS AJM, GRIFFITHS RD, CAMPBELL IT, GREEN CJ <i>et al.</i> NECROTIZING MYOPATHY IN CRITICALLY ILL PATIENTS. <i>Journal of Pathology</i> 1991; 164 :307-14.	52
HANSENFLASCHEN J, COWEN J, POLOMANO RC. BEYOND THE RAMSAY SCALE - NEED FOR A VALIDATED MEASURE OF SEDATING DRUG EFFICACY IN THE INTENSIVE CARE UNIT. <i>Critical Care Medicine</i> 1994; 22 :732-3.	52
GENTILELLO LM, COBEAN RA, OFFNER PJ, SODERBERG RW, JURKOVICH GJ. CONTINUOUS ARTERIOVENOUS REWARMING - RAPID REVERSAL OF HYPOTHERMIA IN CRITICALLY ILL PATIENTS. <i>Journal of Trauma-Injury Infection and Critical Care</i> 1992; 32 :316-27.	52
GALAMBOS R, HICKS GE, WILSON MJ. THE AUDITORY BRAIN STEM RESPONSE RELIABLY PREDICTS HEARING LOSS IN GRADUATES OF A TERTIARY INTENSIVE CARE NURSERY. <i>Ear and Hearing</i> 1984; 5 :254-60.	52
FISER DH. ASSESSING THE OUTCOME OF PEDIATRIC INTENSIVE CARE. <i>Journal of Pediatrics</i> 1992; 121 :68-74.	52
FIDDIANGREEN RG. SHOULD MEASUREMENTS OF TISSUE PH AND PO ₂ BE INCLUDED IN THE ROUTINE MONITORING OF INTENSIVE CARE UNIT PATIENTS. <i>Critical Care Medicine</i> 1991; 19 :141-3.	52
ESCARCE JJ, KELLEY MA. ADMISSION SOURCE TO THE MEDICAL INTENSIVE CARE UNIT PREDICTS HOSPITAL DEATH INDEPENDENT OF APACHE-II SCORE. <i>Journal of the American Medical Association</i> 1990; 264 :2389-94.	52
CHELLURI L, GRENVIK A, SILVERMAN M. INTENSIVE CARE FOR CRITICALLY ILL ELDERLY - MORTALITY, COSTS, AND QUALITY OF LIFE - REVIEW OF THE LITERATURE. <i>Archives of Internal Medicine</i> 1995; 155 :1013-22.	52

CADE JF. HIGH-RISK OF THE CRITICALLY ILL FOR VENOUS THROMBOEMBOLISM. <i>Critical Care Medicine</i> 1982; 10 :448-50.	52
BEDDOE AH, STREAT SJ, HILL GL. EVALUATION OF AN IN VIVO PROMPT GAMMA NEUTRON-ACTIVATION FACILITY FOR BODY COMPOSITION STUDIES IN CRITICALLY ILL INTENSIVE CARE PATIENTS - RESULTS ON 41 NORMALS. <i>Metabolism-Clinical and Experimental</i> 1984; 33 :270-80.	52
ATKINSON S, BIHARI D, SMITHIES M, DALY K, MASON R, MCCOLL I. IDENTIFICATION OF FUTILITY IN INTENSIVE CARE. <i>Lancet</i> 1994; 344 :1203-6.	52
WILKINSON JD, POLLACK MM, GLASS NL, KANTER RK, KATZ RW, STEINHART CM. MORTALITY ASSOCIATED WITH MULTIPLE ORGAN SYSTEM FAILURE AND SEPSIS IN PEDIATRIC INTENSIVE CARE UNIT. <i>Journal of Pediatrics</i> 1987; 111 :324-8.	51
SMITH I, FLEMING S, CERNAIANU A. MISHAPS DURING TRANSPORT FROM THE INTENSIVE CARE UNIT. <i>Critical Care Medicine</i> 1990; 18 :278-81.	51
ROGY MA, COYLE SM, OLDENBURG HSA, ROCK CS, BARIE PS, VANZEE KJ <i>et al.</i> PERSISTENTLY EL-EVATED SOLUBLE TUMOR NECROSIS FACTOR RECEPTOR AND INTERLEUKIN-1 RECEPTOR ANTAGONIST LEVELS IN CRITICALLY ILL PATIENTS. <i>Journal of the American College of Surgeons</i> 1994; 178 :132-8.	51
RELLO J, QUINTANA E, AUSINA V, PUZO C, NET A, PRATS G. RISK FACTORS FOR STAPHYLOCOCCUS AUREUS NOSOCOMIAL PNEUMONIA IN CRITICALLY ILL PATIENTS. <i>American Review of Respiratory Disease</i> 1990; 142 :1320-4.	51
RAMSAY DA, ZOCHODNE DW, ROBERTSON DM, NAG S, LUDWIN SK. A SYNDROME OF ACUTE SEVERE MUSCLE NECROSIS IN INTENSIVE CARE UNIT PATIENTS. <i>Journal of Neuropathology and Experimental Neurology</i> 1993; 52 :387-98.	51
MORO ML, VIGANO EF, LEPRI AC. RISK FACTORS FOR CENTRAL VENOUS CATHETER-RELATED INFECTIONS IN SURGICAL AND INTENSIVE CARE UNITS. <i>Infection Control and Hospital Epidemiology</i> 1994; 15 :253-64.	51
FRIEDLAND JS, PORTER JC, DARYANANI S, BLAND JM, SCREATON NJ, VESELY MJJ <i>et al.</i> PLASMA PROINFLAMMATORY CYTOKINE CONCENTRATIONS, ACUTE PHYSIOLOGY AND CHRONIC HEALTH EVALUATION (APACHE) III SCORES AND SURVIVAL IN PATIENTS IN AN INTENSIVE CARE UNIT. <i>Critical Care Medicine</i> 1996; 24 :1775-81.	51
COUDRON PE, MAYHALL CG, FACKLAM RR, SPADORA AC, LAMB VA, LYBRAND MR <i>et al.</i> STREPTOCOCCUS FAECIUM OUTBREAK IN A NEONATAL INTENSIVE-CARE UNIT. <i>Journal of Clinical Microbiology</i> 1984; 20 :1044-8.	51
BOLDT J, MENGES T, WOLLBRUCK M, HAMMERMANN H, HEMPELMANN G. IS CONTINUOUS CARDIAC OUTPUT MEASUREMENT USING THERMODILUTION RELIABLE IN THE CRITICALLY ILL PATIENT. <i>Critical Care Medicine</i> 1994; 22 :1913-8.	51
AFESSA B, TEFFERI A, HOAGLAND HC, LETENDRE L, PETERS SG. OUTCOME OF RECIPIENTS OF BONE MARROW TRANSPLANTS WHO REQUIRE INTENSIVE CARE UNIT SUPPORT. <i>Mayo Clinic Proceedings</i> 1992; 67 :117-22.	51
ZALOGA GP, CHERNOW B, SMALLRIDGE RC, ZAJTCHUK R, HALLBOYER K, HARGRAVES R <i>et al.</i> A LONGITUDINAL EVALUATION OF THYROID FUNCTION IN CRITICALLY ILL SURGICAL PATIENTS. <i>Annals of Surgery</i> 1985; 201 :456-64.	50
VIERHAPPER H, LAGGNER A, WALDHAUSL W, GRUBECKLOEBENSTEIN B, KLEINBERGER G. IMPAIRED SECRETION OF TSH IN CRITICALLY ILL PATIENTS WITH LOW T4 SYNDROME. <i>Acta Endocrinologica</i> 1982; 101 :542-9.	50
SCHEFFLER RM, KNAUS WA, WAGNER DP, ZIMMERMAN JE. SEVERITY OF ILLNESS AND THE RELATIONSHIP BETWEEN INTENSIVE CARE AND SURVIVAL. <i>American Journal of Public Health</i> 1982; 72 :449-54.	50
NYBERG SL, SHATFORD RA, HU WS, PAYNE WD, CERRA FB. HEPATOCYTE CULTURE SYSTEMS FOR ARTIFICIAL LIVER SUPPORT - IMPLICATIONS FOR CRITICAL CARE MEDICINE (BIOARTIFICIAL LIVER SUPPORT). <i>Critical Care Medicine</i> 1992; 20 :1157-68.	50
MARIK PE, HAVLIK I, MONTEAGUDO FSE, LIPMAN J. THE PHARMACOKINETICS OF AMIKACIN IN CRITICALLY ILL ADULT AND PEDIATRIC PATIENTS - COMPARISON OF ONCE-DAILY VERSUS TWICE- DAILY DOSING REGIMENS. <i>Journal of Antimicrobial Chemotherapy</i> 1991; 27 :81-9.	50
MANSHIP L, MCMILLIN RD, BROWN JJ. THE INFLUENCE OF SEPSIS AND MULTISYSTEM AND ORGAN FAILURE ON MORTALITY IN THE SURGICAL INTENSIVE CARE UNIT. <i>American Surgeon</i> 1984; 50 :94-101.	50

HENNING RJ, MCCLISH D, DALY B, NEARMAN H, FRANKLIN C, JACKSON D. CLINICAL CHARACTERISTICS AND RESOURCE UTILIZATION OF ICU PATIENTS - IMPLICATIONS FOR ORGANIZATION OF INTENSIVE CARE. <i>Critical Care Medicine</i> 1987; 15 :264-9.	50
HEBERT PC, WELLS G, TWEEDDALE M, MARTIN C, MARSHALL J, PHAM B <i>et al</i> . DOES TRANSFUSION PRACTICE AFFECT MORTALITY IN CRITICALLY ILL PATIENTS? <i>American Journal of Respiratory and Critical Care Medicine</i> 1997; 155 :1618-23.	50
HAUSER MJ, TABAK J, BAIER H. SURVIVAL OF PATIENTS WITH CANCER IN A MEDICAL CRITICAL CARE UNIT. <i>Archives of Internal Medicine</i> 1982; 142 :527-9.	50
EDDLESTON JM, VOHRA A, SCOTT P, TOOTH JA, PEARSON RC, MCCLOY RF <i>et al</i> . A COMPARISON OF THE FREQUENCY OF STRESS ULCERATION AND SECONDARY PNEUMONIA IN SUCCRALFATE-TREATED OR RANITIDINE-TREATED INTENSIVE CARE UNIT PATIENTS. <i>Critical Care Medicine</i> 1991; 19 :1491-6.	50
COCKERILL FR, MULLER SR, ANHALT JP, MARSH HM, FARNELL MB, MUCHA P <i>et al</i> . PREVENTION OF INFECTION IN CRITICALLY ILL PATIENTS BY SELECTIVE DECONTAMINATION OF THE DIGESTIVE TRACT. <i>Annals of Internal Medicine</i> 1992; 117 :545-53.	50
CHANG RWS. INDIVIDUAL OUTCOME PREDICTION MODELS FOR INTENSIVE CARE UNITS. <i>Lancet</i> 1989; 2 :143-6.	50
BERSTEN AD, RUTTEN AJ, VEDIG AE, SKOWRONSKI GA. ADDITIONAL WORK OF BREATHING IMPOSED BY ENDOTRACHEAL TUBES, BREATHING CIRCUITS, AND INTENSIVE CARE VENTILATORS. <i>Critical Care Medicine</i> 1989; 17 :671-7.	50
TOWNSEND TR, WENZEL RP. NOSOCOMIAL BLOOD STREAM INFECTIONS IN A NEWBORN INTENSIVE CARE UNIT - A CASE-MATCHED CONTROL STUDY OF MORBIDITY, MORTALITY AND RISK. <i>American Journal of Epidemiology</i> 1981; 114 :73-80.	49
REUSSER P, GYR K, SCHEIDEGGER D, BUCHMANN B, BUSER M, ZIMMERLI W. PROSPECTIVE ENDOSCOPIC STUDY OF STRESS EROSIONS AND ULCERS IN CRITICALLY ILL NEUROSURGICAL PATIENTS - CURRENT INCIDENCE AND EFFECT OF ACID-REDUCING PROPHYLAXIS. <i>Critical Care Medicine</i> 1990; 18 :270-4.	49
RAPOPORT J, GEHLBACH S, LEMESHOW S, TERES D. RESOURCE UTILIZATION AMONG INTENSIVE CARE PATIENTS - MANAGED CARE VS TRADITIONAL INSURANCE. <i>Archives of Internal Medicine</i> 1992; 152 :2207-12.	49
OBLADEN M, SACHSENWEGER M, STAHNKE M. BLOOD SAMPLING IN VERY LOW BIRTH WEIGHT INFANTS RECEIVING DIFFERENT LEVELS OF INTENSIVE CARE. <i>European Journal of Pediatrics</i> 1988; 147 :399-404.	49
MILLIGAN JE, SHENNAN AT, HOSKINS EM. PERINATAL INTENSIVE CARE - WHERE AND HOW TO DRAW THE LINE. <i>American Journal of Obstetrics and Gynecology</i> 1984; 148 :499-503.	49
MCLEAN RF, MCINTOSH JD, KUNG GY, LEUNG DMW, BYRICK RJ. OUTCOME OF RESPIRATORY INTENSIVE CARE FOR THE ELDERLY. <i>Critical Care Medicine</i> 1985; 13 :625-9.	49
MACHIEDO GW, LOVERME PJ, MCGOVERN PJ, BLACKWOOD JM. PATTERNS OF MORTALITY IN A SURGICAL INTENSIVE CARE UNIT. <i>Surgery Gynecology & Obstetrics</i> 1981; 152 :757-9.	49
LANDRY FJ, PARKER JM, PHILLIPS YY. OUTCOME OF CARDIOPULMONARY RESUSCITATION IN THE INTENSIVE CARE SETTING. <i>Archives of Internal Medicine</i> 1992; 152 :2305-8.	49
JORDAN KG. CONTINUOUS EEG AND EVOKED POTENTIAL MONITORING IN THE NEUROSCIENCE INTENSIVE CARE UNIT. <i>Journal of Clinical Neurophysiology</i> 1993; 10 :445-75.	49
EAGLE KA, MULLEY AG, SKATES SJ, REDER VA, NICHOLSON BW, SEXTON JO <i>et al</i> . LENGTH OF STAY IN THE INTENSIVE CARE UNIT - EFFECTS OF PRACTICE GUIDELINES AND FEEDBACK. <i>Journal of the American Medical Association</i> 1990; 264 :992-7.	49
DUKE GJ, BERSTEN AD. DOPAMINE AND RENAL SALVAGE IN THE CRITICALLY ILL PATIENT. <i>Anaesthesia and Intensive Care</i> 1992; 20 :277-87.	49
BROWN WJ, BUIST NRM, GIPSON HTC, HUSTON RK, KENNAWAY NG. FATAL BENZYL ALCOHOL POISONING IN A NEONATAL INTENSIVE CARE UNIT. <i>Lancet</i> 1982; 1 :1250.	49
MADOFF RD, SHARPE SM, FATH JJ, SIMMONS RL, CERRA FB. PROLONGED SURGICAL INTENSIVE CARE - A USEFUL ALLOCATION OF MEDICAL RESOURCES. <i>Archives of Surgery</i> 1985; 120 :698-702.	48
HARRIS CE, GROUNDS RM, MURRAY AM, LUMLEY J, ROYSTON D, MORGAN M. PROPOFOL FOR LONG-TERM SEDATION IN THE INTENSIVE CARE UNIT - A COMPARISON WITH PAPAVERETUM AND MIDAZOLAM. <i>Anaesthesia</i> 1990; 45 :366-72.	48

FAIST E, STORCK M, HULTNER L, REDL H, ERTEL W, WALZ A <i>et al.</i> FUNCTIONAL ANALYSIS OF MONOCYTE ACTIVITY THROUGH SYNTHESIS PATTERNS OF PROINFLAMMATORY CYTOKINES AND NEOPTERIN IN PATIENTS IN SURGICAL INTENSIVE CARE. <i>Surgery</i> 1992; 112 :562-72.	48
DESIMONE DN, KUNDEL HL, ARENSON RL, SESHADRI SB, BRIKMAN IS, KHALSA SS <i>et al.</i> EFFECT OF A DIGITAL IMAGING NETWORK ON PHYSICIAN BEHAVIOR IN AN INTENSIVE CARE UNIT. <i>Radiology</i> 1988; 169 :41-4.	48
DECHAMPS C, SAUVANT MP, CHANAL C, SIROT D, GAZUY N, MALHURET R <i>et al.</i> PROSPECTIVE SURVEY OF COLONIZATION AND INFECTION CAUSED BY EXPANDED-SPECTRUM-BETA-LACTAMASE-PRODUCING MEMBERS OF THE FAMILY ENTEROBACTERIACEAE IN AN INTENSIVE CARE UNIT. <i>Journal of Clinical Microbiology</i> 1989; 27 :2887-90.	48
BEDDOE AH, ZUIDMEER H, HILL GL. A PROMPT GAMMA IN VIVO NEUTRON ACTIVATION ANALYSIS FACILITY FOR MEASUREMENT OF TOTAL BODY NITROGEN IN THE CRITICALLY ILL. <i>Physics in Medicine and Biology</i> 1984; 29 :371-83.	48
AZIMI PH, ROBERTO RR, GURALNIK J, LIVERMORE T, HOAG S, HAGENS S <i>et al.</i> TRANSFUSION-ACQUIRED HEPATITIS-A IN A PREMATURE INFANT WITH SECONDARY NOSOCOMIAL SPREAD IN AN INTENSIVE CARE NURSERY. <i>American Journal of Diseases of Children</i> 1986; 140 :23-7.	48
SPURNEY RF, FULKERSON WJ, SCHWAB SJ. ACUTE RENAL FAILURE IN CRITICALLY ILL PATIENTS - PROGNOSIS FOR RECOVERY OF KIDNEY FUNCTION AFTER PROLONGED DIALYSIS SUPPORT. <i>Critical Care Medicine</i> 1991; 19 :8-11.	47
SPAN LFR, HERMUS ARMM, BARTELINK AKM, HOITSMA AJ, GIMBRERE JSF, SMALS AGH <i>et al.</i> ADRENOCORTICAL FUNCTIONS - AN INDICATOR OF SEVERITY OF DISEASE AND SURVIVAL IN CHRONIC CRITICALLY ILL PATIENTS. <i>Intensive Care Medicine</i> 1992; 18 :93-6.	47
POELAERT JI, TROUERBACH J, DEBUYZERE M, EVERAERT J, COLARDYN FA. EVALUATION OF TRANSESOPHAGEAL ECHOCARDIOGRAPHY AS A DIAGNOSTIC AND THERAPEUTIC AID IN A CRITICAL CARE SETTING. <i>Chest</i> 1995; 107 :774-9.	47
PETERSON MW, GEIST LJ, SCHWARTZ DA, KONICEK S, MOSELEY PL. OUTCOME AFTER CARDIOPULMONARY RESUSCITATION IN A MEDICAL INTENSIVE CARE UNIT. <i>Chest</i> 1991; 100 :168-74.	47
NIEMIEC PW, ALLO MD, MILLER CF. EFFECT OF ALTERED VOLUME OF DISTRIBUTION ON AMINOGLYCOSIDE LEVELS IN PATIENTS IN SURGICAL INTENSIVE CARE. <i>Archives of Surgery</i> 1987; 122 :207-12.	47
GOLDHILL DR, WITHINGTON PS, BIRCH NJ. THE NORTH EAST THAMES REGIONAL INTENSIVE CARE AUDIT SYSTEM. <i>Theoretical Surgery</i> 1993; 8 :1-5.	47
GIRAUD T, DHAINAUT JF, VAXELAIRE JF, JOSEPH T, JOURNOIS D, BLEICHNER G <i>et al.</i> IATROGENIC COMPLICATIONS IN ADULT INTENSIVE CARE UNITS - A PROSPECTIVE 2-CENTER STUDY. <i>Critical Care Medicine</i> 1993; 21 :40-51.	47
FIDDIANGREEN RG, BAKER S. NOSOCOMIAL PNEUMONIA IN THE CRITICALLY ILL - PRODUCT OF ASPIRATION OR TRANSLOCATION. <i>Critical Care Medicine</i> 1991; 19 :763-9.	47
DUTOIT PW, MULLER FO, VANTONDER WM, UNGERER MJ. EXPERIENCE WITH THE INTENSIVE CARE MANAGEMENT OF ORGANO PHOSPHATE INSECTICIDE POISONING. <i>South African Medical Journal</i> 1981; 60 :227-9.	47
DIEBEL LN, WILSON RF, TAGETT MG, KLINE RA. END-DIASTOLIC VOLUME - A BETTER INDICATOR OF PRELOAD IN THE CRITICALLY ILL. <i>Archives of Surgery</i> 1992; 127 :817-22.	47
COHEN IL, BARI N, STROSBERG MA, WEINBERG PF, WACKSMAN RM, MILLSTEIN BH <i>et al.</i> REDUCTION OF DURATION AND COST OF MECHANICAL VENTILATION IN AN INTENSIVE CARE UNIT BY USE OF A VENTILATORY MANAGEMENT TEAM. <i>Critical Care Medicine</i> 1991; 19 :1278-84.	47
BUCHER HU, EDWARDS AD, LIPP AE, DUC G. COMPARISON BETWEEN NEAR-INFRARED SPECTROSCOPY AND Xe-133 CLEARANCE FOR ESTIMATION OF CEREBRAL BLOOD FLOW IN CRITICALLY ILL PRETERM INFANTS. <i>Pediatric Research</i> 1993; 33 :56-60.	47
BION JF, LEDINGHAM IM. SEDATION IN INTENSIVE CARE - A POSTAL SURVEY. <i>Intensive Care Medicine</i> 1987; 13 :215-6.	47
BELLOMO R, RONCO C. ACUTE RENAL FAILURE IN THE INTENSIVE CARE UNIT: ADEQUACY OF DIALYSIS AND THE CASE FOR CONTINUOUS THERAPIES. <i>Nephrology Dialysis Transplantation</i> 1996; 11 :424-8.	47

VOSS R, MATTHIAS FR, BORKOWSKI G, REITZ D. ACTIVATION AND INHIBITION OF FIBRINOLYSIS IN SEPTIC PATIENTS IN AN INTERNAL INTENSIVE CARE UNIT. <i>British Journal of Haematology</i> 1990; 75 :99-105.	46
SHERETZ RJ, GLEDHILL KS, HAMPTON KD, PFALLER MA, GIVNER LB, ABRAMSON JS <i>et al.</i> OUTBREAK OF CANDIDA BLOOD STREAM INFECTIONS ASSOCIATED WITH RETROGRADE MEDICATION ADMINISTRATION IN A NEONATAL INTENSIVE CARE UNIT. <i>Journal of Pediatrics</i> 1992; 120 :455-61.	46
REAH G, BODENHAM AR, MALLICK A, DAILY EK, PRZYBELSKI RJ. INITIAL EVALUATION OF DIASPIRIN CROSS-LINKED HEMOGLOBIN (DCLHB(TM)) AS A VASOPRESSOR IN CRITICALLY ILL PATIENTS. <i>Critical Care Medicine</i> 1997; 25 :1480-8.	46
POTGIETER PD, LINTON DM, OLIVER S, FORDER AA. NOSOCOMIAL INFECTIONS IN A RESPIRATORY INTENSIVE CARE UNIT. <i>Critical Care Medicine</i> 1987; 15 :495-9.	46
NIEDERMAN MS, CRAVEN DE, FEIN AM, SCHULTZ DE. PNEUMONIA IN THE CRITICALLY ILL HOSPITALIZED PATIENT. <i>Chest</i> 1990; 97 :170-81.	46
MAYER JA, DUBBERT PM, MILLER M, BURKETT PA, CHAPMAN SW. INCREASING HANDWASHING IN AN INTENSIVE CARE UNIT. <i>Infection Control and Hospital Epidemiology</i> 1986; 7 :259-62.	46
KOCH KA, RODEFFER HD, Wears RL. CHANGING PATTERNS OF TERMINAL CARE MANAGEMENT IN AN INTENSIVE CARE UNIT. <i>Critical Care Medicine</i> 1994; 22 :233-43.	46
JOHNSTON CC, STEVENS BJ. EXPERIENCE IN A NEONATAL INTENSIVE CARE UNIT AFFECTS PAIN RESPONSE. <i>Pediatrics</i> 1996; 98 :925-30.	46
HALLER M, ZOLLNER C, BRIEGEL J, FORST H. EVALUATION OF A NEW CONTINUOUS THERMODILUTION CARDIAC OUTPUT MONITOR IN CRITICALLY ILL PATIENTS - A PROSPECTIVE CRITERION STANDARD STUDY. <i>Critical Care Medicine</i> 1995; 23 :860-6.	46
FINK MP, HELSMOORTEL CM, STEIN KL, LEE PC, COHN SM. THE EFFICACY OF AN OSCILLATING BED IN THE PREVENTION OF LOWER RESPIRATORY TRACT INFECTION IN CRITICALLY ILL VICTIMS OF BLUNT TRAUMA - A PROSPECTIVE-STUDY. <i>Chest</i> 1990; 97 :132-7.	46
CHONG JL, PILLAI R, FISHER A, GREBENIK C, SINCLAIR M, WESTABY S. CARDIAC SURGERY - MOVING AWAY FROM INTENSIVE CARE. <i>British Heart Journal</i> 1992; 68 :430-3.	46
SUMMER WR, MICHAEL JR, LIPSKY JJ. INITIAL AMINOGLYCOSIDE LEVELS IN THE CRITICALLY ILL. <i>Critical Care Medicine</i> 1983; 11 :948-50.	45
SIRIO CA, TAJIMI K, TASE C, KNAUS WA, WAGNER DP, HIRASAWA H <i>et al.</i> AN INITIAL COMPARISON OF INTENSIVE CARE IN JAPAN AND THE UNITED STATES. <i>Critical Care Medicine</i> 1992; 20 :1207-15.	45
SINANAN M, MAIER RV, CARRICO J. LAPAROTOMY FOR INTRA ABDOMINAL SEPSIS IN PATIENTS IN AN INTENSIVE CARE UNIT. <i>Archives of Surgery</i> 1984; 119 :652-8.	45
ROCHA LA, MARTIN MJ, PITA S, PAZ J, SECO C, MARGUSINO L <i>et al.</i> PREVENTION OF NOSOCOMIAL INFECTION IN CRITICALLY ILL PATIENTS BY SELECTIVE DECONTAMINATION OF THE DIGESTIVE TRACT - A RANDOMIZED, DOUBLE BLIND, PLACEBO-CONTROLLED STUDY. <i>Intensive Care Medicine</i> 1992; 18 :398-404.	45
GROLL A, SIMON JB, WIGLE RD, TAGUCHI K, TODD RJ, DEPEW WT. CIMETIDINE PROPHYLAXIS FOR GASTROINTESTINAL BLEEDING IN AN INTENSIVE CARE UNIT. <i>Gut</i> 1986; 27 :135-40.	45
FLAHERTY J, NATHAN C, KABINS SA, WEINSTEIN RA. PILOT TRIAL OF SELECTIVE DECONTAMINATION FOR PREVENTION OF BACTERIAL INFECTION IN AN INTENSIVE CARE UNIT. <i>Journal of Infectious Diseases</i> 1990; 162 :1393-7.	45
CALVIN JE, DRIEDGER AA, SIBBALD WJ. THE HEMODYNAMIC EFFECT OF RAPID FLUID INFUSION IN CRITICALLY ILL PATIENTS. <i>Surgery</i> 1981; 90 :61-76.	45
ZALOGA GP. HYPOCALCEMIA IN CRITICALLY ILL PATIENTS. <i>Critical Care Medicine</i> 1992; 20 :251-62.	44
YU VYH, HOOKHAM DM, NAVE JRM. RETROLENTAL FIBROPLASIA - CONTROLLED STUDY OF 4 YEARS EXPERIENCE IN A NEONATAL INTENSIVE CARE UNIT. <i>Archives of Disease in Childhood</i> 1982; 57 :247-52.	44
VALLES J, LEON C, ALVAREZLERMA F. NOSOCOMIAL BACTEREMIA IN CRITICALLY ILL PATIENTS: A MULTICENTER STUDY EVALUATING EPIDEMIOLOGY AND PROGNOSIS. <i>Clinical Infectious Diseases</i> 1997; 24 :387-95.	44
TERES D, BROWN RB, LEMESHOW S. PREDICTING MORTALITY OF INTENSIVE CARE UNIT PATIENTS - THE IMPORTANCE OF COMA. <i>Critical Care Medicine</i> 1982; 10 :86-95.	44

STAHLMAN MT. NEWBORN INTENSIVE CARE - SUCCESS OR FAILURE. <i>Journal of Pediatrics</i> 1984; 105 :162-7.	44
NASSOURA Z, IVATURY RR, SIMON RJ, JABBOUR N, STAHL WM, DELLINGER EP <i>et al.</i> CANDIDURIA AS AN EARLY MARKER OF DISSEMINATED INFECTION IN CRITICALLY ILL SURGICAL PATIENTS - THE ROLE OF FLUCONAZOLE THERAPY. <i>Journal of Trauma-Injury Infection and Critical Care</i> 1993; 35 :290-5.	44
LEE DKP, SWINBURNE AJ, FEDULLO AJ, WAHL GW. WITHDRAWING CARE - EXPERIENCE IN A MEDICAL INTENSIVE CARE UNIT. <i>Journal of the American Medical Association</i> 1994; 271 :1358-61.	44
HIGGINS TL, YARED JP, ESTAFANOUS FG, COYLE JP, KO HK, GOODALE DB. PROPOFOL VERSUS MIDAZOLAM FOR INTENSIVE CARE UNIT SEDATION AFTER CORONARY ARTERY BYPASS-GRAFTING. <i>Critical Care Medicine</i> 1994; 22 :1415-23.	44
HEYLAND D, COOK DJ, WINDER B, BRYLOWSKI L, VANDEMARK H, GUYATT G. ENTERAL NUTRITION IN THE CRITICALLY ILL PATIENT - A PROSPECTIVE SURVEY. <i>Critical Care Medicine</i> 1995; 23 :1055-60.	44
GETCHELLWHITE SI, DONOWITZ LG, GROSCHEL DHM. THE INANIMATE ENVIRONMENT OF AN INTENSIVE CARE UNIT AS A POTENTIAL SOURCE OF NOSOCOMIAL BACTERIA - EVIDENCE FOR LONG SURVIVAL OF ACINETOBACTER CALCOACETICUS. <i>Infection Control and Hospital Epidemiology</i> 1989; 10 :402-7.	44
ESSERMAN L, BELKORA J, LENERT L. POTENTIALLY INEFFECTIVE CARE - A NEW OUTCOME TO ASSESS THE LIMITS OF CRITICAL CARE. <i>Journal of the American Medical Association</i> 1995; 274 :1544-51.	44
COLLISON ME, MEYERHOFF ME. CHEMICAL SENSORS FOR BEDSIDE MONITORING OF CRITICALLY ILL PATIENTS. <i>Analytical Chemistry</i> 1990; 62 :A425-&.	44
CHANDRASEKAR PH, KRUSE JA, MATHEWS MF. NOSOCOMIAL INFECTION AMONG PATIENTS IN DIFFERENT TYPES OF INTENSIVE CARE UNITS AT A CITY HOSPITAL. <i>Critical Care Medicine</i> 1986; 14 :508-10.	44
BECKSAGUE CM, AZIMI P, FONSECA SN, BALTIMORE RS, POWELL DA, BLAND LA <i>et al.</i> BLOODSTREAM INFECTIONS IN NEONATAL INTENSIVE CARE UNIT PATIENTS - RESULTS OF A MULTICENTER STUDY. <i>Pediatric Infectious Disease Journal</i> 1994; 13 :1110-6.	44
VAN DEN BERGHE G, WOUTERS P, WEEKERS F, VERWAEST C, BRUYNINCKX F, SCHETZ M <i>et al.</i> INTENSIVE INSULIN THERAPY IN CRITICALLY ILL PATIENTS. <i>New England Journal of Medicine</i> 2001; 345 :1359-67.	43
SHELLY MP, SULTAN MA, BODENHAM A, PARK GR. MIDAZOLAM INFUSIONS IN CRITICALLY ILL PATIENTS. <i>European Journal of Anaesthesiology</i> 1991; 8 :21-7.	43
SCOTT RPF. CARDIOPULMONARY RESUSCITATION IN A TEACHING HOSPITAL - A SURVEY OF CARDIAC ARRESTS OCCURRING OUTSIDE INTENSIVE CARE UNITS AND EMERGENCY ROOMS. <i>Anaesthesia</i> 1981; 36 :526-30.	43
SANDHU B, COOKE RWI, STEVENSON RC, PHAROAH POD. COST OF NEONATAL INTENSIVE CARE FOR VERY-LOW-BIRTH-WEIGHT INFANTS. <i>Lancet</i> 1986; 1 :600-3.	43
RONCO C. CONTINUOUS RENAL REPLACEMENT THERAPIES FOR THE TREATMENT OF ACUTE RENAL FAILURE IN INTENSIVE CARE PATIENTS. <i>Clinical Nephrology</i> 1993; 40 :187-98.	43
ROGERS PL, LANE HC, HENDERSON DK, PARRILLO J, MASUR H. ADMISSION OF AIDS PATIENTS TO A MEDICAL INTENSIVE CARE UNIT - CAUSES AND OUTCOME. <i>Critical Care Medicine</i> 1989; 17 :113-7.	43
RIDLEY S, JACKSON R, FINDLAY J, WALLACE P. LONG-TERM SURVIVAL AFTER INTENSIVE CARE. <i>British Medical Journal</i> 1990; 301 :1127-30.	43
PITTET D, THIEVENT B, WENZEL RP, LI N, GURMAN G, SUTER PM. IMPORTANCE OF PREEXISTING COMORBIDITIES FOR PROGNOSIS OF SEPTICEMIA IN CRITICALLY ILL PATIENTS. <i>Intensive Care Medicine</i> 1993; 19 :265-72.	43
JARLIER V, FOSSE T, PHILIPPON A. ANTIBIOTIC SUSCEPTIBILITY IN AEROBIC GRAM-NEGATIVE BACILLI ISOLATED IN INTENSIVE CARE UNITS IN 39 FRENCH TEACHING HOSPITALS (ICU STUDY). <i>Intensive Care Medicine</i> 1996; 22 :1057-65.	43
GOTTLIEB JE, MENASHE PI, CRUZ E. GASTROINTESTINAL COMPLICATIONS IN CRITICALLY ILL PATIENTS - THE INTENSIVISTS OVERVIEW. <i>American Journal of Gastroenterology</i> 1986; 81 :227-38.	43
DIVE A, MOULART M, JONARD P, JAMART J, MAHIEU P. GASTRODUODENAL MOTILITY IN MECHANICALLY VENTILATED CRITICALLY ILL PATIENTS - A MANOMETRIC STUDY. <i>Critical Care Medicine</i> 1994; 22 :441-7.	43

CHERNOW B, SMITH J, RAINEY TG, FINTON C. SPECIAL ARTICLE - HYPOMAGNESEMIA - IMPLICATIONS FOR THE CRITICAL CARE SPECIALIST. <i>Critical Care Medicine</i> 1982; 10 :193-6.	43
BELLOMO R, MARTIN H, PARKIN G, LOVE J, KEARLEY Y, BOYCE N. CONTINUOUS ARTERIOVENOUS HEMODIAFILTRATION IN THE CRITICALLY ILL - INFLUENCE ON MAJOR NUTRIENT BALANCES. <i>Intensive Care Medicine</i> 1991; 17 :399-402.	43
BALL M, MOORE RA, FISHER A, MCQUAY HJ, ALLEN MC, SEAR J. RENAL FAILURE AND THE USE OF MORPHINE IN INTENSIVE CARE. <i>Lancet</i> 1985; 1 :784-6.	43
WU AW, RUBIN HR, ROSEN MJ. ARE ELDERLY PEOPLE LESS RESPONSIVE TO INTENSIVE CARE. <i>Journal of the American Geriatrics Society</i> 1990; 38 :621-7.	42
WACHTER RM, LUCE JM, HOPEWELL PC. CRITICAL CARE OF PATIENTS WITH AIDS. <i>Journal of the American Medical Association</i> 1992; 267 :541-7.	42
SHAPIRO BA, WARREN J, EGOL AB, GREENBAUM DM, JACOBI J, NASRAWAY SA <i>et al.</i> PRACTICE PARAMETERS FOR SUSTAINED NEUROMUSCULAR BLOCKADE IN THE ADULT CRITICALLY ILL PATIENT - AN EXECUTIVE SUMMARY. <i>Critical Care Medicine</i> 1995; 23 :1601-5.	42
ROTSTEIN OD, PRUETT TL, SIMMONS RL. MICROBIOLOGIC FEATURES AND TREATMENT OF PERSISTENT PERITONITIS IN PATIENTS IN THE INTENSIVE CARE UNIT. <i>Canadian Journal of Surgery</i> 1986; 29 :247-50.	42
POLLACK MM, YEH TS, RUTTAMAN UE, HOLBROOK PR, FIELDS AI. EVALUATION OF PEDIATRIC INTENSIVE CARE. <i>Critical Care Medicine</i> 1984; 12 :376-83.	42
NORWOOD SH, CIVETTA JM. ABDOMINAL CT SCANNING IN CRITICALLY ILL SURGICAL PATIENTS. <i>Annals of Surgery</i> 1985; 202 :166-75.	42
NISKANEN M, KARI A, NIKKI P, IISALO E, KAUKINEN L, RAUHALA V <i>et al.</i> ACUTE PHYSIOLOGY AND CHRONIC HEALTH EVALUATION (APACHE II) AND GLASGOW COMA SCORES AS PREDICTORS OF OUTCOME FROM INTENSIVE CARE AFTER CARDIAC ARREST. <i>Critical Care Medicine</i> 1991; 19 :1465-73.	42
MUCKART DJJ, BHAGWANJEE S. AMERICAN COLLEGE OF CHEST PHYSICIANS SOCIETY OF CRITICAL CARE MEDICINE CONSENSUS CONFERENCE DEFINITIONS OF THE SYSTEMIC INFLAMMATORY RESPONSE SYNDROME AND ALLIED DISORDERS IN RELATION TO CRITICALLY INJURED PATIENTS. <i>Critical Care Medicine</i> 1997; 25 :1789-95.	42
MITCHELL PH, ARMSTRONG S, SIMPSON TF, LENTZ M. AMERICAN ASSOCIATION OF CRITICAL CARE NURSES DEMONSTRATION PROJECT - PROFILE OF EXCELLENCE IN CRITICAL CARE NURSING. <i>Heart & Lung</i> 1989; 18 :219-37.	42
MEYERHOFF ME. NEW IN VITRO ANALYTICAL APPROACHES FOR CLINICAL CHEMISTRY MEASUREMENTS IN CRITICAL CARE. <i>Clinical Chemistry</i> 1990; 36 :1567-72.	42
MANTHOU CA, HALL JB, OLSON D, SINGH M, CHATILA W, POHLMAN A <i>et al.</i> EFFECT OF COOLING ON OXYGEN-CONSUMPTION IN FEBRILE CRITICALLY ILL PATIENTS. <i>American Journal of Respiratory and Critical Care Medicine</i> 1995; 151 :10-4.	42
KRONBERG FG, GOODWIN WJ. SINUSITIS IN INTENSIVE CARE UNIT PATIENTS. <i>Laryngoscope</i> 1985; 95 :936-8.	42
KONG KL, WILLATTS SM, PRYSROBERTS C. ISOFLURANE COMPARED WITH MIDAZOLAM FOR SEDATION IN THE INTENSIVE CARE UNIT. <i>British Medical Journal</i> 1989; 298 :1277-80.	42
KERN MJ, AGUIRRE FV, TATINENI S, PENICK D, SEROTA H, DONOHUE T <i>et al.</i> ENHANCED CORONARY BLOOD FLOW VELOCITY DURING INTRAORTIC BALLOON COUNTERPULSATION IN CRITICALLY ILL PATIENTS. <i>Journal of the American College of Cardiology</i> 1993; 21 :359-68.	42
KATZ R, KELLY W, HSI A. PROSPECTIVE STUDY ON THE OCCURRENCE OF WITHDRAWAL IN CRITICALLY ILL CHILDREN WHO RECEIVE FENTANYL BY CONTINUOUS-INFUSION. <i>Critical Care Medicine</i> 1994; 22 :763-7.	42
HEINONEN PO, JOUSELA IT, BLOMQUIST KA, OLKKOLA KT, TAKKUNEN OS. VALIDATION OF AIR TONOMETRIC MEASUREMENT OF GASTRIC REGIONAL CONCENTRATIONS OF CO2 IN CRITICALLY ILL SEPTIC PATIENTS. <i>Intensive Care Medicine</i> 1997; 23 :524-9.	42
GOLDENHEIM PD, KAZEMI H. CURRENT CONCEPTS - CARDIOPULMONARY MONITORING OF CRITICALLY ILL PATIENTS. <i>New England Journal of Medicine</i> 1984; 311 :776-80.	42
DONOWITZ LG, HALEY CE, GREGORY WW, WENZEL RP. NEONATAL INTENSIVE CARE UNIT BACTEREMIA - EMERGENCE OF GRAM- POSITIVE BACTERIA AS MAJOR PATHOGENS. <i>American Journal of Infection Control</i> 1987; 15 :141-7.	42

COURSIN DB, KLASEK G, GOELZER SL. INCREASED REQUIREMENTS FOR CONTINUOUSLY- INFUSED VECURONIUM IN CRITICALLY ILL PATIENTS. <i>Anesthesia and Analgesia</i> 1989; 69 :518-21.	42
BORRERO E, MARGOLIS IB, BANK S, SHULMAN N, CHARDAVOYNE R. ANTACID VERSUS SUCRALFATE IN PREVENTING ACUTE GASTROINTESTINAL BLEEDING - A RANDOMIZED TRIAL IN 100 CRITICALLY ILL PATIENTS. <i>American Journal of Surgery</i> 1984; 148 :809-12.	42
BLAND RD, SHOEMAKER WC. PROBABILITY OF SURVIVAL AS A PROGNOSTIC AND SEVERITY OF ILLNESS SCORE IN CRITICALLY ILL SURGICAL PATIENTS. <i>Critical Care Medicine</i> 1985; 13 :91-5.	42
BENNET R, ERIKSSON M, NORD CE, ZETTERSTROM R. FECAL BACTERIAL MICROFLORA OF NEWBORN INFANTS DURING INTENSIVE CARE MANAGEMENT AND TREATMENT WITH 5 ANTIBIOTIC REGIMENS. <i>Pediatric Infectious Disease Journal</i> 1986; 5 :533-9.	42
VALENTI WM, CLARKE TA, HALL CB, MENEGUS MA, SHAPIRO DL. CONCURRENT OUTBREAKS OF RHINOVIRUS AND RESPIRATORY SYNCYTIAL VIRUS IN AN INTENSIVE CARE NURSERY - EPIDEMIOLOGY AND ASSOCIATED RISK FACTORS. <i>Journal of Pediatrics</i> 1982; 100 :722-6.	41
SPAPEN HD, DUINSLAEGER L, DILTOER M, GILLET R, BOSSUYT A, HUYGHENS LP. GASTRIC EMPTYING IN CRITICALLY ILL PATIENTS IS ACCELERATED BY ADDING CISAPRIDE TO A STANDARD ENTERAL FEEDING PROTOCOL - RESULTS OF A PROSPECTIVE, RANDOMIZED, CONTROLLED TRIAL. <i>Critical Care Medicine</i> 1995; 23 :481-5.	41
SINGER M, MYERS S, HALL G, COHEN SL, ARMSTRONG RF. THE COST OF INTENSIVE CARE - A COMPARISON ON ONE UNIT BETWEEN 1988 AND 1991. <i>Intensive Care Medicine</i> 1994; 20 :542-9.	41
POLESKI MH, SPANIER AH. CIMETIDINE VERSUS ANTACIDS IN THE PREVENTION OF STRESS EROSIONS IN CRITICALLY ILL PATIENTS. <i>American Journal of Gastroenterology</i> 1986; 81 :107-11.	41
PALMSTIERNA T, HUITFELDT B, WISTEDT B. THE RELATIONSHIP OF CROWDING AND AGGRESSIVE BEHAVIOR ON A PSYCHIATRIC INTENSIVE CARE UNIT. <i>Hospital and Community Psychiatry</i> 1991; 42 :1237-40.	41
MEYER KC, PRIELIPP RC, GROSSMAN JE, COURSIN DB. PROLONGED WEAKNESS AFTER INFUSION OF ATRACURIUM IN 2 INTENSIVE CARE UNIT PATIENTS. <i>Anesthesia and Analgesia</i> 1994; 78 :772-4.	41
MAYEROAKES SA, OYE RK, LEAKE B. PREDICTORS OF MORTALITY IN OLDER PATIENTS FOLLOWING MEDICAL INTENSIVE CARE - THE IMPORTANCE OF FUNCTIONAL STATUS. <i>Journal of the American Geriatrics Society</i> 1991; 39 :862-8.	41
KORINEK AM, LAISNE MJ, NICOLAS MH, RASKINE L, DEROIN V, SANSONLEPORS MJ. SELECTIVE DECONTAMINATION OF THE DIGESTIVE TRACT IN NEUROSURGICAL INTENSIVE CARE UNIT PATIENTS - A DOUBLE-BLIND, RANDOMIZED, PLACEBO-CONTROLLED STUDY. <i>Critical Care Medicine</i> 1993; 21 :1466-73.	41
KIMBLE KJ, ARIAGNO RL, STEVENSON DK, SUNSHINE P. GROWTH TO AGE 3 YEARS AMONG VERY-LOW-BIRTH-WEIGHT SEQUELAE-FREE SURVIVORS OF MODERN NEONATAL INTENSIVE CARE. <i>Journal of Pediatrics</i> 1982; 100 :622-4.	41
IDRIS AH, BECKER LB, ORNATO JP, HEDGES JR, BIRCHER NG, CHANDRA NC <i>et al.</i> UTSTEIN-STYLE GUIDELINES FOR UNIFORM REPORTING OF LABORATORY CPR RESEARCH - A STATEMENT FOR HEALTHCARE PROFESSIONALS FROM A TASK FORCE OF THE AMERICAN HEART ASSOCIATION, THE AMERICAN COLLEGE OF EMERGENCY PHYSICIANS, THE AMERICAN COLLEGE OF CARDIOLOGY, THE EUROPEAN RESUSCITATION COUNCIL, THE HEART AND STROKE FOUNDATION OF CANADA, THE INSTITUTE OF CRITICAL CARE MEDICINE, THE SAFAR CENTER FOR RESUSCITATION RESEARCH, AND THE SOCIETY FOR ACADEMIC EMERGENCY MEDICINE. <i>Circulation</i> 1996; 94 :2324-36.	41
HALPERN NA, BETTES L, GREENSTEIN R. FEDERAL AND NATIONWIDE INTENSIVE CARE UNITS AND HEALTH CARE COSTS - 1986-1992. <i>Critical Care Medicine</i> 1994; 22 :2001-7.	41
DIVE A, MIESSE C, GALANTI L, JAMART J, EVRARD P, GONZALEZ M <i>et al.</i> EFFECT OF ERYTHROMYCIN ON GASTRIC MOTILITY IN MECHANICALLY VENTILATED CRITICALLY ILL PATIENTS - A DOUBLE-BLIND, RANDOMIZED, PLACEBO-CONTROLLED STUDY. <i>Critical Care Medicine</i> 1995; 23 :1356-62.	41
CHRISTENSEN GD, KORONES SB, REED L, BULLEY R, MCLAUGHLIN B, BISNO AL. EPIDEMIC SERRATIA MARCESCENS IN A NEONATAL INTENSIVE CARE UNIT - IMPORTANCE OF THE GASTROINTESTINAL TRACT AS A RESERVOIR. <i>Infection Control and Hospital Epidemiology</i> 1982; 3 :127-33.	41
BLANCH L, MANCEBO J, PEREZ M, MARTINEZ M, MAS A, BETBESE AJ <i>et al.</i> SHORT-TERM EFFECTS OF PRONE POSITION IN CRITICALLY ILL PATIENTS WITH ACUTE RESPIRATORY DISTRESS SYNDROME. <i>Intensive Care Medicine</i> 1997; 23 :1033-9.	41

VANDENBROUCKEGRAULS CMJE, KERVER AJH, ROMMES JH, JANSEN R, DENDEKKER C, VERHOEF J. ENDEMIC ACINETOBACTER ANITRATUS IN A SURGICAL INTENSIVE CARE UNIT - MECHANICAL VENTILATORS AS RESERVOIR. <i>European Journal of Clinical Microbiology & Infectious Diseases</i> 1988; 7 :485-9.	40
STRETTON M, AJIZIAN SJ, MITCHELL I, NEWTH CJL. INTENSIVE CARE COURSE AND OUTCOME OF PATIENTS INFECTED WITH RESPIRATORY SYNCYTIAL VIRUS. <i>Pediatric Pulmonology</i> 1992; 13 :143-50.	40
SMITH RL, LEVINE SM, LEWIS ML. PROGNOSIS OF PATIENTS WITH AIDS REQUIRING INTENSIVE CARE. <i>Chest</i> 1989; 96 :857-61.	40
SHELLMAN RG, FULKERSON WJ, DELONG E, PIANTADOSI CA. PROGNOSIS OF PATIENTS WITH CIRRHOSIS AND CHRONIC LIVER DISEASE ADMITTED TO THE MEDICAL INTENSIVE CARE UNIT. <i>Critical Care Medicine</i> 1988; 16 :671-8.	40
SELL EJ, GAINES JA, GLUCKMAN C, WILLIAMS E. EARLY IDENTIFICATION OF LEARNING PROBLEMS IN NEONATAL INTENSIVE CARE GRADUATES. <i>American Journal of Diseases of Children</i> 1985; 139 :460-3.	40
RONCO JJ, PHANG PT. VALIDATION OF AN INDIRECT CALORIMETER TO MEASURE OXYGEN CONSUMPTION IN CRITICALLY ILL PATIENTS. <i>Journal of Critical Care</i> 1991; 6 :36-41.	40
MOLDAN B, SCHNOOR JL. CZECHOSLOVAKIA - EXAMINING A CRITICALLY ILL ENVIRONMENT. <i>Environmental Science & Technology</i> 1992; 26 :14-21.	40
LLOYDTHOMAS AR, WRIGHT I, LISTER TA, HINDS CJ. PROGNOSIS OF PATIENTS RECEIVING INTENSIVE CARE FOR LIFE-THREATENING MEDICAL COMPLICATIONS OF HEMATOLOGICAL MALIGNANCY. <i>British Medical Journal</i> 1988; 296 :1025-9.	40
LIM CF, DOCTER R, VISSER TJ, KRENNING EP, BERNARD B, VANTOOR H <i>et al.</i> INHIBITION OF THYROXINE TRANSPORT INTO CULTURED RAT HEPATOCYTES BY SERUM OF NONUREMIC CRITICALLY ILL PATIENTS - EFFECTS OF BILIRUBIN AND NONESTERIFIED FATTY ACIDS. <i>Journal of Clinical Endocrinology and Metabolism</i> 1993; 76 :1165-72.	40
HANIQUE G, DUGERNIER T, LATERRE PF, DOUGNAC A, ROESELER J, REYNAERT MS. SIGNIFICANCE OF PATHOLOGICAL OXYGEN-SUPPLY DEPENDENCY IN CRITICALLY ILL PATIENTS - COMPARISON BETWEEN MEASURED AND CALCULATED METHODS. <i>Intensive Care Medicine</i> 1994; 20 :12-8.	40
GRATTARD F, POZZETTO B, BERTHELOT P, RAYET I, ROS A, LAURAS B <i>et al.</i> ARBITRARILY- PRIMED PCR, RIBOTYPING, AND PLASMID PATTERN ANALYSIS APPLIED TO INVESTIGATION OF A NOSOCOMIAL OUTBREAK DUE TO ENTEROBACTER CLOACAE IN A NEONATAL INTENSIVE CARE UNIT. <i>Journal of Clinical Microbiology</i> 1994; 32 :596-602.	40
GOLUB R, SORRENTO JJ, CANTU R, NIERMAN DM, MOIDEEN A, STEIN HD. EFFICACY OF ALBUMIN SUPPLEMENTATION IN THE SURGICAL INTENSIVE CARE UNIT - A PROSPECTIVE, RANDOMIZED STUDY. <i>Critical Care Medicine</i> 1994; 22 :613-9.	40
DUXBURY ML, ARMSTRONG GD, DREW DJ, HENLY SJ. HEAD NURSE LEADERSHIP STYLE WITH STAFF NURSE BURNOUT AND JOB SATISFACTION IN NEONATAL INTENSIVE CARE UNITS. <i>Nursing Research</i> 1984; 33 :97-101.	40
CRONINSTUBBS D, ROOKS CA. THE STRESS, SOCIAL SUPPORT, AND BURNOUT OF CRITICAL CARE NURSES - THE RESULTS OF RESEARCH. <i>Heart & Lung</i> 1985; 14 :31-9.	40

Disclaimer

In order to provide the most commonly cited papers, a relatively narrow search based on key words was used. Those key words were selected to pick up the majority of Critical Care publications, but clearly any such strategy is not comprehensive. In contrast, for individual papers, any citation in *Medline* will be recorded. Hence, there will be a discrepancy between the numbers found in '*the most commonly cited papers*' and the citations for individual papers.

The 25 most frequently mentioned authors in articles on Critical Care and related subjects. The time periods 1970–2008 as total, 2002–2008 and 1998–2002 have been shown.

The 25 most frequently cited authors by year periods.
From 1970–2008 Total of 64,964 citations.

Field: Author	Record Count	% of 64964
[ANON]	398	0.6126%
VINCENT, JL	306	0.4710%
BELLOMO, R.	255	0.3925%
KOLLEF, MH	175	0.2694%
RONCO, C	169	0.2601%
REINHART, K	141	0.2170%
COOK, DJ	139	0.2140%
ANGUS, DC	120	0.1847%
MARTIN, C	120	0.1847%
TORRES, A	120	0.1847%
BOLDT, J	113	0.1739%
TAKALA, J	111	0.1709%
POLLACK, MM	109	0.1678%
GASTMEIER, P	103	0.1585%
AZOULAY, E	102	0.1570%
PITTET, D	101	0.1555%
SPRUNG, CL	99	0.1524%
KNAUS, WA	95	0.1462%
SIBBALD, WJ	94	0.1447%
BROCHARD, L	93	0.1432%
MARIK, PE	93	0.1432%
EMPELMANN, G	91	0.1401%
RELLO, J	90	0.1385%
LIPMAN, J	88	0.1355%
RUDEN, H	88	0.1355%

Years 1998–2002 (citations total 17,062)

Field: Author	Record Count	% of 17062
[ANON]	97	0.5685%
VINCENT, JL	90	0.5275%
BELLOMO, R	75	0.4396%
KOLLEF, MH	56	0.3282%
RONCO, C	53	0.3106%
TORRES, A	51	0.2989%
TAKALA, J	48	0.2813%
REINHART, K	46	0.2696%
COOK, DJ	40	0.2344%
BOLDT, J	39	0.2286%
MARIK, PE	38	0.2227%
BRUN-BUISSON, C	37	0.2169%
PITTET, D	37	0.2169%
COOK, D	34	0.1993%
HEYLAND, DK	34	0.1993%
MARTIN, C	34	0.1993%
MEIER-HELLMANN, A	34	0.1993%
ANGUS, DC	33	0.1934%
VAN AKEN, H	32	0.1876%
PINSKY, MR	31	0.1817%
BURCHARDI, H	30	0.1758%
BROCHARD, L	29	0.1700%
HEMPELMANN, G	29	0.1700%
JARVIS, WR	29	0.1700%
BARIE, PS	27	0.1582%

Years 2003–2008 (Total 26234 citation)

Field: Author	Record Count	% of 26234
VINCENT, JL	148	0.5642%
BELLOMO, R	141	0.5375%
[ANON]	105	0.4002%
RONCO, C	96	0.3659%
KOLLEF, MH	83	0.3164%
ANGUS, DC	82	0.3126%
AZOULAY, E	76	0.2897%
GASTMEIER, P	72	0.2745%
REINHART, K	63	0.2401%
VAN DEN BERGHE, G	62	0.2363%
COOK, DJ	60	0.2287%
ELY, EW	59	0.2249%
AFESSA, B	58	0.2211%
PRONOVOST, PJ	57	0.2173%
CURTIS, JR	53	0.2020%
KELLUM, JA	53	0.2020%
MARTIN, C	52	0.1982%
BROCHARD, L	50	0.1906%
SCHULTZ, MJ	50	0.1906%
FALAGAS, ME	49	0.1868%
RELLO, J	49	0.1868%
SINGER, M	49	0.1868%
DE BACKER, D	48	0.1830%
PITTET, D	48	0.1830%
FRASER, VJ	46	0.1753%

Index

- abdomen
 - infections, multiple system organ failure, 226–7
 - surgery, dexmedetomidine preventing acute gastroduodenal inflammation after, 404–5
 - trauma, early enteral nutrition, 228–9
 - see also truncal injury
- acetaminophen (paracetamol)-induced liver failure
 - acetylcysteine therapy, 185–7
 - prognostic indicators, 181–2
- acetylcysteine in acetaminophen-induced liver failure, 185–7
- acid-base disturbances, septic shock, 241–4
- acidosis
 - in experimental shock, hidden, 126–7
 - metabolic, see metabolic acidosis
 - in sepsis and septic shock, 241–4
 - fluid management in septic patients with lactic acidosis, 260–3
- acquired immunodeficiency syndrome, see AIDS
- activated protein C, recombinant human, in severe sepsis, 270–4
- acute physiology and chronic health evaluation (APACHE II) score, 449, 458–9, 541–2
- acute respiratory distress syndrome,
 - see respiratory distress syndrome
- adenosine production, ischemic kidney, 150–1
- adult respiratory distress syndrome, see respiratory distress syndrome
- AIDS (HIV disease)
 - P. carinii* pneumonia, see *Pneumocystis carinii* pneumonia
 - recognition as new disease, 362–3
 - respiratory failure, improved outcomes and increased use of ICUs, 364–5
- airflow obstruction, chronic, see chronic obstructive pulmonary disease
- airway pressure, see pressure
- airway pressure, high, causing pulmonary edema, 15–16
- albumin, intravenous
 - in cirrhosis and bacterial peritonitis, renal impairment, mortality and effects of, 190–1
 - controversial results of systematic review, 324–5
- alkalosis, septic shock, 242
- alfentanil, withdrawal, 411–12
- alveolar over-distension in mechanical ventilation, injurious effects, 21
- American College of Chest Physicians' Consensus Conference on mechanical ventilation, 21–2
- American-European Consensus Conference on ARDS, on definitions/mechanisms/outcomes/clinical trial coordination, 38–9
- amino acids
 - excitatory, in brain injury, 100–3
 - metabolism in sepsis and trauma, 283–4
- p*-aminomethylbenzene sulfonamide, burn wound sepsis, 197–8
- amphotericin B vs. fluconazole for candidemia, 376–7
- analgesia, 407–26
- analgesic nephropathy, 148–9
- anesthesia
 - epidural, high-risk surgical patients, 423–4
 - halothane, in status asthmaticus, 524–5
- anoxia in isolated perfused kidney, medullary thick ascending limb lesion, 154–5
- antibiotics, see antimicrobials
- antidiuresis of standing, 146–7
- antifungals, candidemia, 376–7
- antimicrobials/anti-infectives (primarily antibiotics/antibacterials)
 - bloodstream infection, effects on outcome, 332–4
 - burn patients, topical, 193, 197–8
 - computer-assisted management program, 338–40
 - dosing regimens and pharmacokinetic/pharmacodynamic parameters, 335–7
 - meningitis, 347–9
 - resistance to, 327
 - methicillin-resistant *Staphylococcus aureus*, 368–9
 - multi-drug resistant *Serratia marcescens*, 374–5
 - in National Nosocomial Infections Surveillance system report (2001), 329–31
 - sepsis/septic shock, 275
 - Gram-negative, 239–40
- antiseptic, cutaneous, in prevention of catheter-related infections, 355–6
- antiserum to endotoxin in Gram-negative bacteremia and septic shock, 253–5
- anuric patients, continuous hemofiltration, 152–3
- aorta, balloon counterpulsation in, effects on hemodynamics and myocardial metabolism in MI complicated by shock, 78–80
- APACHE II score, 449, 458–9, 541–2
- Apgar score, 449, 450–1
- apoptosis (programmed cell death), in brain trauma, 104–7
- arginine, enteral nutrition supplementation with (in Impact), 293, 301
- L-arginine analogues attenuating adverse effects of IL-2 immunotherapy, 513–14
- arterial catheters
 - cutaneous antiseptic in prevention of infections, 355–6
 - pulmonary, see pulmonary artery catheters

- arterial oxygen saturation, spectrophotometric determination, 434–5
- arteriovenous hemofiltration, anuric patients, 152–3
- aspirin-induced renal dysfunction, 148–9
see also salicylates
- asthma
halothane anesthesia in status asthmaticus, 524–5
mechanical ventilation in, auto-PEEP, 12
- atrial pressure
cardiac performance following MI complicated by shock and effects of, 76–7
measurement of right a.p.
balloon-tipped catheter, 430
thermal dilution, 428–9
pulmonary edema development and effects of left a.p., 308–10
- auto-PEEP, 1, 10–12, 21
- bacteremia
Gram-negative, *see* Gram-negative organisms
lethal, monoclonal antibodies to TNF preventing septic shock in, 502–3
- bacterial endotoxin, *see* endotoxin
- balloon-tipped cardiac catheter, 430–1
for intra-aortic counterpulsation, effects on hemodynamics and myocardial metabolism in MI complicated by shock, 78–80
- Bcl-2 and brain injury, 104–7
- benzodiazepines for sedation, postal survey, 411
- biocompatible dialysis membranes, 156–7
- bleeding, *see* hemorrhage; hemorrhagic shock
- blood flow
cerebral, nitrous oxide method of determining, 443–4
gut, in hemorrhagic shock, 120–1
heart and lung, mean velocity calculation, 66–7
heart maintaining, Harvey's work, 61–3
hepatic, in hypoxic/ischemic hepatitis, 177–8
see also perfusion
- blood glucose level, management of, 557–9
- blood, hepatitis B transmission risk to staff in dialysis unit, 378–9
- blood loss, *see* hemorrhage; hemorrhagic shock
- blood pressure regulation with raised intracranial pressure, 89–90
see also hypotension
- blood transfusion, 303
critically ill patients' requirements, 541
exchange transfusion in acute hepatic coma, 188–9
and isotonic salt after hemorrhagic shock and operation, 315–16
randomized, controlled trial, 540
start (in 1930s), 306–7
- blood volume
calculation, 66–7
reduced, *see* hypovolemia
- bloodstream infection, antimicrobial effects on outcome, 332–4
- body composition
hemorrhage effects on, 311–12
parenteral nutrition in postoperative intensive care not preventing changes in, 285–6
- body surface area calculations, burns, 205–6
- bowel, role in shock, 119–40
- brain imaging, CT, 93–5
- brain injury, severe traumatic, 87–119
intracranial pressure monitoring, 91–2, 436–7
secondary brain injury in
in determination of outcome, 98–9
prevention, 115–17
in whiplash shaken infant syndrome, 530–1
- breathing, rapid shallow, predicting outcome of weaning from mechanical ventilation, 19–20
- burns, 193–214
percentage body surface area calculations, 205–6
- cachectin, *see* tumor necrosis factor
- calcitonin precursors as markers of sepsis, 344–6
- caloric requirements, burn patients, 201–2
- Canadian health care workers in decisions on withdrawing life, 486–7
- candidiasis, 358
fluconazole vs. amphotericin B for candidemia, 376–7
- capacitance vessels of skeletal muscle in hemorrhagic shock, 124–5
- capillary filtration transfer in skeletal muscle in hemorrhagic shock, 124–5
- capillary fluid and Starling's hypothesis, 304–5
- cardiac arrest with induced hypothermia comatose survivors, 546
randomized, controlled trial, 545
- cardiomyopathic heart failure, dopamine vs dobutamine, 388–9
- cardiopulmonary bypass, cardiac surgery with, cardiac output estimation after, 441–2
- cardiopulmonary failure, extracorporeal membrane oxygenation, 520–1
- cardiotonic drugs, 383–426
see also heart
- cardiovascular system, 59–85
- caspases and brain injury, 104–6
- catecholamines
endogenous, and thermal injury, 203–4
inotropic, dobutamine as, 386–7
- catheter
central, *see* central line catheters
infections associated with, 358, 372–3
cutaneous antiseptics in prevention of, 355–6
- catheterization
cardiac, *see* heart

- pulmonary artery, *see* pulmonary artery catheter
- ceftriaxone vs. cefuroxime in bacterial meningitis, 347–9
- central line catheters, 372–3
 - infection associated with, 358, 372–3
 - cutaneous antiseptics in prevention of, 355–6
 - scheduled replacement, controlled trial, 372–3
- cephalosporins in bacterial meningitis, 347–9
- cerebral blood flow, nitrous oxide method of determining, 443–4
- cerebral pressure/perfusion pressure, *see* intracranial pressure
- chest, flail, avoiding mechanical ventilation, 222–3
- child abuse, brain damage, 530–1
- children, 517–37
 - morphine pharmacokinetics before/after liver transplantation, 419–20
 - propofol, adverse effects, 417–18
 - risk of mortality (PRISM) score, 449, 460–1, 536–7
 - splenic trauma, 220–1
 - see also* infants; neonates
- chronic obstructive pulmonary disease
 - auto-PEEP in, 10–12
 - non-invasive ventilation, 23–4
- circulation, 59–85
- circulatory shock, *see* shock
- cirrhosis, 169–70
 - intravenous albumin effects on renal impairment
 - and mortality in bacterial peritonitis and, 190–1
- coagulopathy in critical injury, terminating laparotomy, 232–3
- colloid osmotic pressure and pulmonary edema, 308–10
- colloid transfusion, 303
- coma
 - acute hepatic, exchange transfusion, 188–9
 - assessment, 96–7, 452–3
 - irreversible, definition, 493–4
- compliance (lung) in optimum end-expiratory pressure indication, 8–9
- computed tomography
 - in acute respiratory distress syndrome, 31
 - in acute respiratory failure
 - during PEEP, 13–15, 50–2
 - during prone ventilation, 55
 - head, 93–5
- computer-assisted management program for anti-infectives, 338–40
- connective tissue spaces, fluid absorption from, 304–5
- consciousness assessment, 96–7, 452–3
- consent, informed, 476–7
- continuous positive airway pressure in infant respiratory distress syndrome, 518–19
- Copenhagen, polio epidemic, 1, 3–5
- coronary bypass surgery in New York State, improving outcomes, 468–9
- coronary care unit, ischemic/hypoxic hepatitis incidence, 177–8
- corticosteroids, *see* steroids
- cranial CT, 93–5
- craniopharyngioma, CT, 95
- critically ill patients
 - blood transfusion requirements, 540–1
 - life support (LS), withdrawal, 550–1
- CROP index, predicting outcome of weaning from mechanical ventilation, 19–20
- crush injuries, renal consequences, 144–5
- crystalloid plus blood in hemorrhage, experimental study, 315–16
- cuprophane dialysis membrane, 156
- Cushing response, 87
- cystic brain lesions, CT, 95
- cytokines, 495–516
 - in ARDS pathogenesis, 32–4
 - early paper describing properties, 496–7
 - in mechanical ventilation, release, 25–7
- death, *see* mortality
- decision-making in end-of-life care, 470–1, 482–92
- defence, host, liver in, 173–4
- Denmark, polio epidemic, 1, 3–5
- dermis, artificial, temporary, burns patients, 209–10
- dexamethasone
 - meningitis, 350–1
 - septic shock, 245–7
- dialysis
 - biocompatible membranes, 156–7
 - historical background, 143, 153
 - see also* hemofiltration
- dialysis unit, hepatitis B hazard to staff, 378–9
- diet and dietary support, *see* nutrition
- digoxin vs. dobutamine in heart failure and MI, 390–1
- discharge from ICU, follow-up after, 425–6
- dobutamine, 386–99, 402–3
 - in circulatory shock, 386–7, 394–5
 - in heart failure, 386–91
 - digoxin vs., 390–1
 - dopamine vs., 388–9
 - in MI, *see* myocardial infarction
 - oxygen uptake and supply (delivery)
 - in response to test infusion, 396–7
 - in sepsis syndrome, 398–9
 - oxygen uptake and supply (delivery)
 - in therapeutic trial of, 402–3
 - sepsis and septic shock, 542
- dopamine, 383
 - in heart failure
 - dobutamine compared with, 388–9
 - sodium diuresis with, 384–5
 - in renal dysfunction (early), 163–7

- dopamine (*cont.*)
 in septic shock, vs. norepinephrine, hemodynamic effects, 400–1
- dopexamine, 383, 404–5
 in acute gastroduodenal inflammation after abdominal surgery, 404–5
- Doppler, esophageal, continuous hemodynamic monitoring, 445–7
- drotrecogin alfa in severe sepsis, 270–4
- ductus arteriosus, dilation by PGE1, 532–3
- duodenum
 dopexamine preventing acute inflammation after abdominal surgery, 404–5
 erosions/ulcers in thermal injury, 199–200
- dye dilution technique, 60, 66–7
- dying patient
 life support (LS) withdrawal, 550–1
 treatment decision-making, 470–1, 482–92
- edema, pulmonary
 fluid management and, 317–21
 left atrial pressure and, 308–10
 in MI complicated by shock, influence of atrial pressure, 76–7
 plasma protein concentration and, 308–10
 ventilation causing, 1
 PEEP protective effects, 6–7, 15–16
- ejection fraction in septic shock, 136–8, 256–9
- electrolytes
 management, burn patients, 193
 requirements in burn patients, calculation, 195–6
- EMI-scanner, 93–5
- encephalopathy, hepatic, exchange transfusion, 188–9
- end-expiratory pressure in acute pulmonary failure, optimum, 8–9
- end-of-life treatment decision-making, 470–1, 482–92
- endocrinology, renal, historical background, 142
- endotoxin (lipopolysaccharide; LPS), 237
 antiserum to, in Gram-negative bacteremia and septic shock, 253–5
 monoclonal antibodies to, in Gram-negative bacteremia and septic shock, 504–5
 mucosal permeability changes due to mesenteric hypoperfusion in etiology, 139–40
 in traumatic and hemorrhagic shock, 122–3
- endotracheal intubation, *see* intubation
- energy metabolism in sepsis and trauma, 283–4
- energy requirements, burn patients, 201–2
- enteral nutrition, 228–9, 281, 291–4, 299–302
 in trauma, 228–9, 291–2, 299–300
 abdominal trauma patients, 228–9
 glutamine-enriched, 282, 299–300
 immune-enhanced diet, 291–2, 301–2
- EPIC (European Prevalence of Infection in Intensive Care) Study, 358, 366–7
- epidermis, Silastic, temporary, burns patients, 209–10
- epidural anesthesia/analgesia, high-risk surgical patients, 423–4
- Escherichia coli* J5 antiserum in Gram-negative bacteremia and septic shock, 253–5
- esophageal Doppler, continuous hemodynamic monitoring, 445–7
- ethics, 473–94
 clinical research and, 474–5
- etomidate, 415–16
 adverse effects, 415–16
 withdrawal, 411–12
- European Prevalence of Infection in Intensive Care (EPIC) Study, 358, 366–7
- exchange transfusion in acute hepatic coma, 188–9
- excitatory amino acids in brain injury, 100–3
- extracellular fluid
 postoperative changes in, 313–14
 Starling's hypothesis and, 304–5
 volume
 in hemorrhagic shock, 216–17
 Ringer's lactate and, surgical patient, 317–19
- extracorporeal gas exchange/membrane oxygenation
 in ARDS, 40–1
 in cardiopulmonary failure, 520–1
- extracorporeal liver support in acute hepatic coma, 188–9
- eye opening in Glasgow coma scale, 97, 453
- family preferences for medical intensive care, 480–1
- femoral fractures, early vs. delayed stabilization, 230–2
- Fick, Adolf, 59
- Fick's method, 59, 64–5
 cardiac surgery patients with cardiopulmonary bypass, 441–2
 Fick's paper, 64–5
- fish oil supplements in enteral nutrition (in Impact), 293, 301
- flail chest, avoiding mechanical ventilation, 222–3
- fluconazole vs. amphotericin B for candidemia, 376–7
- fluid(s), 303–25
 management, 303, 315–25
 anuric patients, 152–3
 burn patients, 193
 hemorrhagic shock, 216–17, 315–16
 hypotensive patients with penetrating torso injuries, 234–5, 322–3
 septic patients, 275–6
 septic patients with lactic acidosis, 260–3
 physiology, 303–5, 308–14
 requirements, burn patients, calculation, 195–6

- resuscitation
 - albumin vs. saline, 552–3
 - meta analysis and systematic review flaws, 553
- follow-up after discharge from ICU, 425–6
- fractures, femoral, early vs. delayed stabilization, 230–2
- Frank–Starling Law of the Heart, 59, 71–3
- free radicals in intestinal ischemia, 132–3
- futility, medical, 482–3

- gastric problems, *see* stomach
- gastrointestinal tract role in shock, 119–40
 - see also specific regions*
- gay men, AIDS first recognized in, 362–3
- Glasgow coma scale, 96–7, 452–3
- glioblastoma, CT, 95
- glomerulus
 - dysfunction in anoxia, 154–5
 - filtration rate during standing, 146–7
- glutamine enrichment
 - enteral nutrition, 282, 299–300
 - parenteral nutrition, 281–2, 295–6
- glycemic control, 352–4
- goal-directed therapy
 - sepsis and septic shock, 542–4
 - pulmonary artery catheters use vs. standard care, 547, 549
- grafting, *see* transplantation
- Gram-negative organisms, 369
 - bacteremia and septic shock
 - antimicrobial therapy and steroids, 239–40
 - E. coli* J5 antiserum in, 253–5
 - HA-1A (anti-endotoxin) monoclonal antibody therapy, 504–5
 - morbidity and mortality, 369
- guide wire, scheduled replacement, controlled trial, 372–3
- gut's role in shock, 119–40 *see also specific regions*

- HA-1A (anti-endotoxin) monoclonal antibody therapy in Gram-negative bacteremia and septic shock, 504–5
- hematoma, subdural, traumatic acute, 108–10
- hemodialysis
 - biocompatible membranes, 156–7
 - historical background, 143, 153
- hemodynamics
 - in acetaminophen-induced liver failure, acetylcysteine improving, 185–7
 - dobutamine effects on, 394–5
 - in heart failure, 388–9
 - dopamine effects on
 - in heart failure, 388–9
 - in septic shock, 400–1
 - esophageal Doppler continuous monitoring, 445–7
 - norepinephrine effects
 - and isoproterenol and intra-aortic balloon counterpulsation in MI complicated by shock, 78–80
 - in septic shock, 400–1
 - tumor immunotherapy with IL-2 and adverse effects on, 513–14
- hemofiltration, continuous, anuric patients, 152–3
- hemorrhage
 - intracranial and intraocular, in whiplash shaken infant syndrome, 530–1
 - venous (non-shock), body composition and effects of, 311–12
- hemorrhagic shock
 - endotoxin in, 122–3
 - fluid therapy, 216–17, 315–16
 - gut and splanchnic circulation contribution to outcome of, 120–1
 - hyperosmolar NaCl, 130–1
 - lactate and pyruvate as indicators of, 432–3
 - skeletal muscle in, 124–5
- halothane anesthesia in status asthmaticus, 524–5
- hand hygiene, 380–1
- Harvey, William, 59
- head, CT, 93–5
 - see also* brain injury
- health professionals, *see* staff
- heart, 59–85
 - blood flow in, mean velocity calculation, 66–7
 - in blood flow maintenance, Harvey's work, 61–3
 - cardiotonic drugs, 383–426
 - catheterization, 60, 430–1
 - balloon-tipped, *see* balloon-tipped cardiac catheter
 - ductus-dependent congenital defects, PGE1 maintaining patency, 532–3
- failure
 - dobutamine in, *see* dobutamine
 - dopamine in, *see* dopamine
 - ischemic/hypoxic hepatitis in, 177–8
 - Valsalva manoeuvre, 74–5
- function/performance
 - animal model for assessing, 71–3
 - atrial pressure effects on, MI complicated by shock, 76–7
- index (=cardiac index), supranormal values as therapeutic goals in high-risk surgery, 83–5
- output
 - intermittent positive pressure breathing effects on, 68–70
 - in septic shock, and its maintenance, 243
- output measurement, 59–60
 - dye dilution method, 60, 66–7
 - Fick's method, 64–5, 441–2
 - esophageal Doppler, 445–7

- heart, (*cont.*)
 post-cardiac surgery with cardiopulmonary bypass, 441–2
 pulmonary artery catheterization, 441–2
 thermal dilution method, 428–9
 postoperative shock in obstructive jaundice and role of, 175–6
- hepatic disorders, *see* liver
- hepatitis
 ischemic/hypoxic, 169, 177–8
 viral
 IFN- α in HCV therapy, 511–12
 staff hazard in dialysis units, 378–9
- high frequency oscillatory ventilation, lung volume maintenance preventing lung injury in, 526–7
- Hippocrates, 169
- HIV, *see* AIDS
- homosexual men, AIDS first recognized in, 362–3
- hospital-acquired infection, *see* infection
- host defence, liver in, 173–4
- human immunodeficiency virus, *see* AIDS
- hyaline membrane disease, *see* respiratory distress syndrome, infant hydrocephalus, CT
- hydrocortisone, Gram-negative septic shock, 239–40
- hydrostatic pressure and pulmonary edema, 308–10
- hygiene, hand, 380–1
- hypercapnia, permissive, severe ARDS, with pressure limited ventilation, low mortality associated with, 17–18
- hyperglycemia, management, 352–4, 557–9
- hypermetabolic response, thermal injury, 203–4
- hyperosmolar NaCl in hemorrhagic shock, 130–1
- hypertension, neonatal persistent pulmonary, NO inhalation in, 528–9
- hyperventilation in severe head injury, prolonged, adverse effects, 111–14
- hypoperfusion, mesenteric, in etiology of LPS-induced changes in mucosal permeability, 139–40
- hypotension
 acute renal failure due to, 158–60
 hemorrhagic, skeletal muscle, 124–5
 in penetrating torso injury, fluid management, 234–5, 322–3
 in tumor immunotherapy with IL-2, 513–14
- hypothermia in critical injury, terminating laparotomy, 232–3
- hypovolemia
 hyperosmolar NaCl, 130–1
 septic shock, 243
- hypoxic hepatitis, 169, 177–8
- immunonutrition, 291–4, 301–2
- immunosuppressive therapy in massive 3rd degree burns, 207–8
- immunotherapy, tumor, nitrogen oxide levels after, 513–14
- Impact (immunonutrition), 293–4, 301–2
- infants
 newborn, *see* neonates
 shaken baby syndrome, 530–1
- infections, 327–81
 in burn patients, topical antibiotics suppressing, 197–8
 control, 357–8, 380–1
 glutamine-enriched enteral nutrition in multitrauma reducing rate of, 299–300
 intra-abdominal, multiple system organ failure, 226–7
 new, 357
 nosocomial/hospital-acquired, 327, 358
 National Nosocomial Infections Surveillance system report (2001), 329–31
 prevalence, EPIC Study, 358, 366–7
see also sepsis
- inflammatory changes in gut mucosa after abdominal surgery, dexamethasone preventing, 404–5
- inflammatory mediator release in mechanical ventilation, 25–7
- inflammatory process, ARDS as, 33
- inflation pressure, high (in ventilation), 1, 15–16
- informed consent, 476–7
- inhalation injury, burn patients, 193, 211–13
- injury
 lung, *see* lung
 traumatic, *see* trauma
- inotropes, 386–99
 in sepsis/septic shock, 276
- inspiratory pressure, limitation reducing mortality in ventilated ARDS patients, 17–19
- insulin therapy
 in surgical ICUs, 352–4
 in medical ICUs, 557–9
- interferon- α in HCV therapy, 511–12
- interleukins, 498–9
 functional relationship, 498–9
 IL-1, 498–9
 historical identification, 496–7
 TNF interactions, 500–1
 IL-2, 498–9
 in tumor immunotherapy, toxicity, 513–14
 IL-8 and ARDS pathogenesis, 32–4
- intermittent positive pressure ventilation
 cardiac output and effects of, 68–70
 pulmonary edema with, protection by PEEP, 6–7
- intestine, role in shock, 119–40
- intra-aortic balloon counterpulsation, effects on hemodynamics and myocardial metabolism in MI complicated by shock, 78–80
- intracranial hemorrhage in whiplash shaken infant syndrome, 530–1
- intracranial pressure (cerebral/ventricular pressure)
 continuous recording in severe acute brain trauma, 91–2, 436–7

- management in prevention of ischemic damage
 - after severe head injury, 115–17
 - raised, vasomotor center controlling blood pressure, 89–90
- intraocular hemorrhage in whiplash shaken infant syndrome, 530–1
- intravenous nutrition, *see* parenteral nutrition
- intubation, endotracheal
 - complications, 1–2
 - in flail chest, avoidance, 222–3
- inverse ratio ventilation, pressure-controlled, in ARDS, 40–1
- ischemia, intestinal, superoxide radicals in, 132–3
- ischemic brain injury
 - excitatory amino acids in, 100–3
 - neurons in, *see* neuronal damage
 - prevention after severe head injury, 115–17
- ischemic hepatitis, 169, 177–8
- ischemic kidney, adenosine production, 150–1
- isoproterenol effects on hemodynamics and myocardial metabolism in MI complicated by shock, 78–80
- jaundice
 - Hippocrates on, 171–2
 - obstructive, postoperative shock in and role of myocardial dysfunction, 175–6
- jejunostomy feeding in abdominal trauma, early, 228–9
- jugular venous desaturation and outcome in severe head injury, 115–17
- Kety-Schmidt method cerebral blood flow determination, 443–4
- kidney, 141–67
 - acute failure
 - biocompatible dialysis membranes, 156–7
 - causes and risk factors, 158–60
 - mortality in, and role of underlying illness, 161–2
 - dysfunction/impairment
 - aspirin-induced, 148–9
 - in crush injuries, 144
 - dopamine in early dysfunction, 163–7
 - intravenous albumin effects on, in cirrhosis and bacterial peritonitis, 190–1
 - historical background, 141–3
 - anatomy, 141
 - dialysis, 143, 155
 - endocrinology, 142
 - investigation techniques, 142
 - nephrology, 141
 - pathophysiology, 143
 - physiology, 142–3
 - surgery, 142
 - transplantation, 144
 - ischemic, adenosine production, 150–1
- Kupffer cells and multiple systems organ failure, 173–4
- lactate as indicator of shock, 432–3
- lactic acidosis, fluid management in septic patients with, 260–3
- laparotomy, emergency, in critical injury abbreviated/ interrupted/terminated, 232–3
- legal issues, informed consent, 476–7
- leukocytic pyrogens, demonstration, 496–7, 500–1
- lidocaine in liver function tests, 179–80
- life support, withholding/withdrawal, 484–7, 491–2
 - in critically ill patients, 550–1
- lignocaine in liver function tests, 179–80
- liver, 169–91
 - chronic disease, 169–70
 - failure, 169
 - acetaminophen-induced, *see* acetaminophen coma (acute) in
 - exchange transfusion
 - early prognostic indicators in fulminant failure, 181–2
 - transplantation in, *see* transplantation
 - function tests, 169, 179–80
 - ischemic/hypoxic disease, 169, 177–8
 - viral infection, *see* hepatitis
- Ludwig, Carl Friedrich William, 141
- Lund and Browder burns chart, 205–6
- lung
 - acute failure, *see* respiratory insufficiency/ failure
 - blood flow in, mean velocity calculation, 66–7
 - compliance, in optimum end-expiratory pressure indication, 8–9
 - edema, *see* edema
 - injury (acute), 31–57
 - alveolar over-distension in mechanical ventilation causing, 21
 - definition, 515–16
 - in high frequency oscillatory ventilation
 - lung volume maintenance preventing, 526–7
 - tidal volume lowering in ventilation improving outcome, 28–9
 - shock, *see* respiratory distress syndrome
 - tidal volume, *see* tidal volume
- lymphatic system and fluid homeostasis (and Starling's hypothesis), 304–5
- Malpighi, Marcello, 141
- marine (fish) oil supplements in enteral nutrition (in Impact), 293, 301
- mechanical ventilation (MV), 1
 - with airflow obstruction, occult PEEP in, 10–12
 - American College of Chest Physicians' Consensus Conference, 21–2
 - fluid resuscitation, 552
 - flail chest and avoidance of, 222–3
 - in intensive insulin therapy, 557
 - life support withdrawal after, 550
 - non-invasive ventilation in avoidance of complications from, 23–4
 - peak inspiratory pressure, adverse effects, 17

- mechanical ventilation (*cont.*)
 prone position, in severe acute respiratory failure, 53–5
 sedation, 409–10
 continuous iv., 421–2
 weaning, indexes predicting outcome, 19–20
 see also specific methods; medical emergency team (MET) system
- medical futility, 482–3
- medico-legal issues, informed consent, 476–7
- medullary thick ascending limb lesion due to anoxia in isolated perfused kidney, 154–5
- MEGX formation kinetics, 179–80
- meningitis (bacterial)
 ceftriaxone vs cefuroxime in, 347–9
 dexamethasone, 350–1
 meningococcal, TNF serum levels and fatal outcome in, 264–6
- meningococcal disease, TNF serum levels and fatal outcome in, 264–6
- mesenteric hypoperfusion in etiology of LPS-induced changes in mucosal permeability, 139–40
- metabolic acidosis
 propofol-induced, children, 417–18
 in sepsis/septic shock, 243
 fluid management in septic patients with lactic acidosis, 260–3
- metabolism, 281–302
 in sepsis, 283–4, 285–6
 in thermal injury, response, 203–4
 in trauma, 283–4
- methicillin-resistant *S. aureus*, 368–9
- methylprednisolone
 in ARDS, prolonged, 45–6
 in septic shock, 245–7
- mixed venous oxygen content, determination, 441–2
- monitoring, 427–47
- monoclonal antibodies
 to endotoxin, in Gram-negative bacteremia and septic shock, 504–5
 to TNF- α , see tumor necrosis factor- α
- monocyte pyrogen, historical demonstration, 496–7
- monoethylglycinexylidide formation kinetics, 179–80
- morphine pharmacokinetics before/after pediatric liver transplantation, 419–20
- mortality (death)
 new definition of death, 493–4
 predicting risk of
 APACHE II score, 458–9
 MPM II system, 466–7
 PRISM score (children), 449, 460–1, 536–7
- Mortality Probability Model (MPM II), 466–7
- motor response in Glasgow coma scale, 97, 453
- MPM II system, 466–7
- mucosa
 gastroduodenal, dopexamine preventing inflammatory changes after abdominal surgery, 404–5
- intestinal
 LPS-induced permeability changes, mesenteric hypoperfusion in etiology of, 139–40
 in shock, 128–9
- multiple (system) organ failure (MOF; MSOF; multiple organ dysfunction syndrome; ODS), 215, 226–7, 248–9, 456–7
 course/outcome/prognosis, 248–9, 456–7
 liver in, 173–4
- muscle (skeletal)
 biochemistry, changes in critical illness, 297–8
 in hemorrhagic shock, 124–5
- myocardial dysfunction (incl. depression/failure)
 postoperative shock in obstructive jaundice and role of, 175–6
 propofol-induced, children, 417–18
 in septic shock, 136–8, 256–9
- myocardial infarction
 complicated by shock
 atrial pressure effects following, 76–7
 isoproterenol/norepinephrine/intra-aortic counterpulsation effects on hemo-dynamics and myocardial metabolism in, 78–80
 dobutamine in, 392–3
 vs. digoxin, 390–1
- myocardial metabolism in MI complicated by shock isoproterenol/norepinephrine/intra-aortic balloon counterpulsation effects on, 78–80
- National Nosocomial Infections Surveillance system report (2001), 329–31
- neonates
 Apgar score, 449, 450–1
 persistent pulmonary hypertension, NO inhalation in, 528–9
 respiratory distress syndrome, see respiratory distress syndrome, infant
 see also infants
- neoplasm, see tumor
- nephrology, historical background, 141
- neuroimaging, CT, 93–5
- neurological assessment, Glasgow coma scale, 96–7, 452–3
- neuronal damage/death after brain trauma and ischemia, 100–3
 programmed, 104–7
- neutrophils and ARDS pathogenesis, 32–4
- newborns, see neonates
- NF[κ]B in mortality of sepsis, 509–10
- nitric oxide
 inhalation
 in ARDS, 35–7

- in persistent pulmonary hypertension of newborn, 528–9
 - levels after tumor immunotherapy, 513–14
- nitrogen, requirements in severe trauma, 287–8
- nitrogen oxide levels after tumor immunotherapy, 513–14
- nitroprusside, sodium, combined with dopamine in MI, 390–1
- nitrous oxide method of cerebral blood flow determination, 443–4
- non-accidental brain injury, children, 530–1
- non-invasive ventilation in COPD, 23–4
- norepinephrine
 - in MI complicated by shock, effects on hemodynamics and myocardial metabolism, 78–80
 - in septic shock, vs. dopamine, hemodynamic effects, 400–1
- nosocomial infection, *see* infection
- nuclear factor kappa B in mortality of sepsis, 509–10
- nucleotide supplements in enteral nutrition (in Impact), 293–4, 301
- nutrition, 281–302
 - burn patients, outcome studies, 281, 287–302
 - immune-enhancing, 291–4, 301–2
 - pathophysiology, 281, 283–6
 - support (incl. dietary support), 281–2, 285–302
 - abdominal trauma, 228–9
 - burn patients, 193, 201–2
- omega-3-fatty acid (fish oil) supplements in enteral nutrition (in Impact), 293, 301
- opioid sedation
 - postal survey, 411
 - ventilated patients, 409
- organ system failure, *see* multiple organ failure
- oxygen
 - arterial saturation, spectrophotometric determination, 434–5
 - arteriovenous concentration difference, measurement by Fick, 64
 - consumption/uptake ($\dot{V}O_2$)
 - dobutamine infusion effects, *see* dobutamine
 - fluid loading increasing, in septic patients with lactic acidosis, 260–3
 - measurement (Fick's method), 64, 441–2
 - supranormal values as therapeutic goals in high-risk surgery, 83–5
 - delivery/supply ($\dot{D}O_2$)
 - dobutamine and, *see* dobutamine
 - supranormal values as therapeutic goals in high-risk surgery, 83–5
 - in renal medulla, reduced tension causing tubular dysfunction, 154–5
- transport
 - in acetaminophen-induced liver failure, acetylcysteine improving, 185–7
 - dobutamine infusion effects, 394–5
 - venous content/saturation, mixed, determination, 441–2
- oxygen free radicals in intestinal ischemia, 132–3
- oxygenation
 - extracorporeal membrane, *see* extracorporeal gas exchange
 - intestinal tissue, assessment, 134–5
- pediatric intensive care, *see* children
- Pediatric Risk of Mortality Score, 449, 460–1, 536–7
- pain relief, 407–26
- pancreatitis, acute, severity assessment, 454–5
- paracetamol, *see* acetaminophen
- parenteral nutrition
 - body composition changes not prevented by, in septic patients, 285–6
 - glutamine-enriched, 281–2, 295–6
 - in postoperative patients, influence on outcome, 289–90
- patient
 - follow-up after discharge from ICU, 425–6
 - informed consent, 476–7
 - preferences for medical intensive care, 480–1
- peak inspiratory pressure in mechanical ventilation, adverse effects, 17
- PEEP, *see* positive end-expiratory pressure
- penetrating torso injury, fluid management in hypotensive patients with, 234–5, 322–3
- peptic ulcers in thermal injury, 199–200
- perfusion (and perfusion pressure)
 - cerebral, *see* intracranial pressure
 - gut
 - and contribution to outcome of hemorrhagic shock, 120–1
 - mesenteric hypoperfusion in etiology of LPS-induced changes in mucosal permeability, 139–40
 - see also* blood flow
- peripheral temperature indicating severity of shock, 438–40
- peritonitis, bacterial, intravenous albumin effects on renal impairment and mortality in cirrhosis and, 190–1
- physical abuse of babies, brain damage, 530–1
- plasma protein concentration and development of pulmonary edema, 308–10
- plasma volume changes during standing, 146–7
- Pneumocystis carinii* pneumonia (in AIDS)
 - improved outcomes and increased use of ICUs, 364–5
 - recognition of association, 362–3
- pneumonia
 - burn patients, 211–13
 - P. carinii*, *see* *Pneumocystis carinii* pneumonia
 - respiratory assistance device-associated (incl. ventilators)
 - invasive and non-invasive management strategies, 341–3

- pneumonia (*cont.*)
 role in endemic nosocomial pneumonia, 370–1
- polio epidemic (Denmark), 1, 3–5
- polyacrylonitrile dialysis membrane, 156
- positive airway pressure, *see* positive pressure ventilation
- positive end-expiratory pressure (PEEP), 1
 auto-/occult, 1, 10–12, 21
 'best'/optimum, in acute respiratory failure, 1, 8–9
 CT studies of lung structure and function during, 13–15, 50–2
 pulmonary edema and protective effects of, 6–7, 15–16
 zero, and inflammatory mediator release, 25–7
- positive pressure ventilation (positive airway pressure)
 cardiac output and effects of, 68–70
 continuous, in infant respiratory distress syndrome, 518–19
 intermittent, *see* intermittent positive pressure ventilation
 polio victims, 3, 4
- postural drainage, polio victims, 3, 4
- pressure, high, in ventilation, 1, 15–16
- pressure-controlled inverse ratio ventilation in ARDS, 40–1
- pressure-limited ventilation with permissive hypercapnia in severe ARDS, low mortality, associated with, 17–18
- pressure-volume curve of total respiratory system in acute respiratory failure, 13–15
- PRISM score, 449, 460–1, 536–7
- procalcitonin as marker of sepsis, 344–6
- programmed cell death in brain trauma, 104–7
- prone mechanical ventilation in severe acute respiratory failure, 53–5
- propofol, children, adverse effects, 417–18
- prostaglandin E1, ductus arteriosus dilation by, 532–3
- protein
 loss
 in sepsis, 285–6
 from skeletal muscle, 297–8
 plasma, and development of pulmonary edema, 308–10
- protein C, activated recombinant human, in severe sepsis, 270–4
- Pseudomonas* burn wound sepsis, topical therapy, 197–8
- pulmonary artery catheters
 fluid management in patients requiring, 320–1
 high-risk surgical patients, use in, 548–9
 mortality/morbidity reduction with, 83, 84
 scheduled replacement, controlled trial, 372–3
- pulmonary artery pressure
 balloon-tipped catheter, 430
 thermal dilution methods of measurement, 428–9
- pulmonary hypertension of newborn, persistent, NO inhalation in, 528–9
- pulmonary non-vascular problems, *see* lung
- pulse oximetry, 434–5
- pyrogens, leukocytic, demonstration, 496–7, 500–1
- pyruvate as indicator of shock, 432–3
- quality of life, patient/family preferences for medical intensive care related to perceptions of, 480–1
- Ranson's criteria, 454–5
- rationing of intensive care, 478–9
- renal support, *see* kidney
- reperfusion injury in intestinal ischemia, 132–3
- research, clinical, ethics and, 474–5
- resistance vessels of skeletal muscle in hemorrhagic shock, 124–5
- resource shortages, physician responses to, 478–9
- respiratory assistance device-associated pneumonia, *see* pneumonia
- respiratory distress syndrome, acute/adult (ARDS; shock lung), 1, 31, 56–7, 218–19
 American-European Consensus Conference on definitions/mechanisms/outcomes/clinical trial coordination, 38–9
 CT in, 31
 definitions, 38–9, 515–16
 extracorporeal CO₂ removal, 40–1
 fatality rates, temporal trends (1983–93), 42–4
 IL-8 in pathogenesis of, 32–4
 liver in pathogenesis of, 173–4
 methylprednisolone therapy, prolonged, 45–6
 NO inhalation, 35–7
 original description, 56–7, 218–19
 pressure limited ventilation with permissive hypercapnia in,
 low mortality associated with, 17–18
 pressure-controlled inverse ratio ventilation, 40–1
 sepsis-induced, *see* sepsis
 tidal volume lowering in ventilation improving outcome, 28–9
- respiratory distress syndrome, infant/neonatal (hyaline membrane disease)
 continuous positive airway pressure, 518–19
 surfactant therapy, 522–3
- respiratory frequency-tidal volume ration predicting outcome of weaning from mechanical ventilation, 19–20
- respiratory insufficiency/failure, acute
 in AIDS, 364–5
 Copenhagen polio epidemic, 1, 3–5
 CT studies of lung structure and function during PEEP, 13–15, 50–2
 end-expiratory pressure, optimum, 8–9

- pressure-volume curve of total respiratory system in, 13–15
- prone mechanical ventilation, 53–5
- respiratory muscle fatigue in cardiogenic shock, 81–2
- Reye's syndrome and salicylates, 534–5
- Ringer's lactate and extracellular fluid volume, surgical patient, 317–19
- salicylates
 - renal dysfunction induced by, 148–9
 - Reye's syndrome with, 534–5
- saline (salt)
 - balanced/isotonic, in hemorrhagic shock, 216–17, 315–16
 - hyperosmolar, in hemorrhagic shock, 130–1
- salt, *see* saline; sodium
- scoring systems, 449–71
 - Pediatric Risk of Mortality Score, 449, 460–1, 536–7
- sedation, 407–26
 - postal survey, 411–12
- sepsis, 237–80
 - in abdominal trauma, jejunostomy feeding in avoidance of, 228–9
 - amino acid and energy metabolism in, 283–4
 - ARDS in
 - liver's role, 173–4
 - surfactant therapy, 47–9
 - burn wound, management, 197–8
 - calcitonin precursors as markers of, 344–6
 - definition, 515–16
 - dobutamine test in, 398–9
 - NF[κ]B in mortality of, 509–10
 - protein loss in, 285–6
 - see also* infection
- sepsis syndrome
 - anti-TNF- α monoclonal antibody, 506–7
 - concept of, 251, 267–8
 - dobutamine test in, 398–9
- septic shock
 - definition, 515–16
 - Gram-negative, *see* Gram-negative organisms
 - monoclonal antibodies to TNF in prevention of, 502–3
 - myocardial depression, 136–8, 256–9
 - norepinephrine vs. dopamine in, 400–1
 - patterns/survival/mortality, 241–4
 - steroids in, *see* steroids
- septicemia, antimicrobial effects on outcome, 332–4
- Serratia marcescens*, 374–5
- severe sepsis and septic shock, 542–4
- severity scoring systems, 454–61
- Shafer (Sharpey-Shafer), EA, 60
- shaken baby syndrome, 530–1
- Sharpey-Shafer, EA, 60
- shock (circulatory), 119–40
 - acidosis in experimental shock, hidden, 126–7
 - cardiogenic
 - following MI, *see* myocardial infarction
 - respiratory muscle fatigue in, 81–2
 - dobutamine in, 386–7, 394–5
 - gut's role in, 119–40
 - hemorrhagic, *see* hemorrhagic shock
 - lactate and pyruvate as indicators of, 432–3
 - peripheral temperature indicating severity, 438–40
 - postoperative, in obstructive jaundice, role of myocardial dysfunction, 175–6
 - septic, *see* septic shock
 - traumatic, *see* trauma
- shock lung, *see* respiratory distress syndrome
- Silastic epidermis, temporary, burns, 209–10
- silver nitrate therapy, primary burn excision and immediate grafting and, 213–14
- skeletal muscle, *see* muscle
- skin
 - antisepsis in prevention of catheter-related infections, 355–6
 - in burns patients artificial, temporary, 209–10
 - primary excision, and immediate grafting, 213–14
 - transplantation, *see* transplantation
- sodium, excretion produced by dopamine in congestive heart failure, 384–5
- sodium, retention
 - in standing, 146–7
 - in stress, 311–12
 - of surgery, 313–14
- sodium chloride, hyperosmolar, in hemorrhagic shock, 130–1
- sodium nitroprusside combined with dopamine in MI, 390–1
- spectrophotometric determination of arterial oxygen saturation, 434–5
- splanchnic circulation, contribution to outcome of hemorrhagic shock, 120–1
- splenic trauma, children, 220–1
- staff/health professionals
 - hand hygiene, 380–1
 - hepatitis B risk to, dialysis unit, 378–9
- standing
 - antidiuresis of, 146–7
 - plasma volume changes and glomerular filtration rate, 146–7
- Staphylococcus aureus*, methicillin-resistant, 368–9
- Starling, EH, 60
 - Starling's hypothesis, 304–5
 - Starling's Law of the Heart, 59, 71–3
- status asthmaticus, halothane anesthesia, 524–5
- steroids
 - in ARDS, prolonged use, 45–6
 - in bacterial meningitis, 350–1
 - in septic shock, 245–7
 - Gram-negative microbes, 239–40

- stomach
- dopexamine preventing acute inflammation after abdominal surgery, 404–5
 - erosions/ulceration in thermal injury, 199–200
 - stress, salt and water retention, *see* sodium; water
 - stroke volume measurement, Fick's work enabling, 64–5
- Study to Understand Prognoses and Preferences for Outcomes and Risk of Treatments (SUPPORT), 449, 470–1, 488–90
- subdural hematoma, traumatic acute, 108–10
- suctioning, polio victims, 3, 4
- Sulfamylon, burn wound sepsis, 197–8
- sulfonamide, topical, burn wound sepsis, 197–8
- superoxide radicals in intestinal ischemia, 132–3
- SUPPORT trial, 449, 470–1, 488–90
- surface area calculations, burns, 205–6
- surfactant therapy
- hyaline membrane disease, 522–3
 - sepsis-induced ARDS, 47–9
- surgery
- abdominal, dopexamine preventing acute gastroduodenal inflammation after, 404–5
 - blood and isotonic salt infusion after, 315–16
 - cardiac
 - coronary bypass, improving outcomes in New York State, 468–9
 - intracardiac, with cardiopulmonary bypass,
 - cardiac output estimation after, 441–2
 - epidural anesthesia and postoperative analgesia in high-risk patients, 423–4
 - extracellular fluid loss, 313–14
 - parenteral nutrition following, influence on outcome, 289–90
 - renal, historical background, 142
 - Ringer's lactate and postoperative pulmonary edema, 317–19
 - shock following, in obstructive jaundice, and role of myocardial dysfunction, 175–6
- Swan–Ganz catheter, 430–1
- systemic septic response, 250–2
- temperature
- core/central, thermal injury, 203–4
 - peripheral, indicating severity of shock, 438–40
- terminal care, decision-making, 470–1, 482–92
- Therapeutic Intervention Scoring System (1983 update), 449, 462–5
- thermal dilution, cardiac output measurement, 428–9
- thermal injury, *see* burns
- thermoregulation in thermal injury, 203–4
- tidal volume
- high
 - inflammatory mediator release with, 25–7
 - pulmonary edema with, 15–16
 - lower, in acute lung injury and acute respiratory distress syndrome, 28–9
 - ratio of respiratory frequency to, predicting outcome of weaning from mechanical ventilation, 19–20
- TISS (Therapeutic Intervention Scoring System - 1983 update), 449, 462–5
- TNF, *see* tumor necrosis factor
- toe temperature indicating severity of shock, 438–40
- tonometry, intestinal tissue oxygenation, 134–5
- tracheal intubation, *see* intubation
- tracheostomy, polio victims, 3–5
- transfusion, *see* blood transfusion
- transplantation/grafting
- liver (e.g. in liver failure)
 - children, morphine pharmacokinetics before/after, 419–20
 - feasibility and success, 183–4
 - indicators, 181–2
 - renal, historical background, 143
 - skin, with burns
 - immediate (after primary burn excision), 213–14
 - temporary (in massive 3rd degree burns), 207–8
- trauma (traumatic injury), 215–35
- amino acid and energy metabolism in, 283–4
 - brain, *see* brain injury
 - crush injuries, renal consequences, 144–5
 - deaths, epidemiology, 224–5
 - enteral nutrition in, *see* enteral nutrition
 - lung, *see* lung
 - mortality in multiple trauma admitted to ICU, related to sedation, 415–16
 - nitrogen requirements, 287–8
 - operative, *see* surgery
 - penetrating torso injuries, fluid management in hypotensive patients, 234–5, 322–3
 - salt and water retention, 312
 - shock in
 - crush injury producing, 144–5
 - endotoxin in, 122–3
 - splenic, children, 220–1
 - treatment decision-making, dying patient, 470–1, 482–92
- truncal (torso) injury, penetrating, fluid management in hypotensive patients with, 234–5, 322–3
- tubular dysfunction in anoxia, 154–5
- tumor
- brain, CT, 95
 - immunotherapy, nitrogen oxide levels after, 513–14
- tumor necrosis factor/TNF (primarily TNF- α ;cachectin)
- IL-1 and, interactions, 500–1
 - mechanical ventilation and, 25, 26
 - in meningococcal disease, serum levels and fatal outcome, 264–6

- monoclonal antibodies to
 - in sepsis syndrome, 506–8
 - in septic shock prevention during lethal bacteremia, 502–3
- typhus, 360–1
- ulcers, gastroduodenal, in thermal injury, 199–200
- Valsalva manoeuvre, normal/failing heart, 74–5
- vasoactive drugs, 383–427
 - vasodilator agents in ARDS, 36
 - vasopressors in sepsis/septic shock, 276
- vasomotor center controlling blood pressure during cerebral compression, 89–90
- venous catheters, central, *see* central line catheters
- venous hemorrhage, body composition and effects of, 311–12
- venous oxygen content/saturation, mixed determination, 441–2
- ventilation, 1–29
 - mechanical, *see* mechanical ventilation *and specific methods*
 - non-invasive, in COPD, 23–4
 - sedation, 409–10
 - continuous i.v., 421–2
 - see also* hyperventilation
 - ventilator-associated pneumonia, *see* pneumonia
 - ventricles (brain), pressure, *see* intracranial pressure
 - ventricles (heart)
 - balloon-tipped catheter in right ventricle, 430
 - ejection fraction in septic shock, 136–8, 256–8
 - function curves, simultaneous left and right, 71–3
 - in obstructive jaundice, impaired performance, 175–6
 - stroke volume in septic shock, 256–8
 - verbal response in Glasgow coma scale, 97, 453
 - viral hepatitis, *see* hepatitis
 - water retention in stress, 311–12
 - of surgery, 313–14
 - weaning from mechanical ventilation, indexes predicting outcome, 19–20
 - whiplash shaken infant syndrome, 530–1
 - withholding/withdrawal life support, 484–7, 491–2