



# Abiotic Stress Adaptation in Plants

*Physiological, Molecular and Genomic Foundation*

Ashwani Pareek · Sudhir K. Sopory  
Hans J. Bohnert · Govindjee  
*Editors*



Springer

# Abiotic Stress Adaptation in Plants

# Abiotic Stress Adaptation in Plants

Physiological, Molecular  
and Genomic Foundation

*Edited by*

**Ashwani Pareek**

*Jawaharlal Nehru University  
New Delhi, India*

**Sudhir K. Sopory**

*International Centre of Genetic Engineering and Biotechnology  
New Delhi, India*

**Hans J. Bohnert**

*University of Illinois at Urbana-Champaign  
Urbana, USA*

and

**Govindjee**

*University of Illinois at Urbana-Champaign  
Urbana, USA*

 Springer

Library of Congress Control Number: 2009941298

ISBN 978-90-481-3111-2 (HB)  
ISBN 978-90-481-3112-9 (e-book)

---

Published by Springer,  
P.O. Box 17, 3300 AA Dordrecht, The Netherlands.

[www.springer.com](http://www.springer.com)

*Front cover artwork symbolizes the impact of abiotic stress on crop plants and the various physiological, molecular and genomic approaches being used to cope up with stress. Left top: Rice, a staple food crop for more than half of the world population and one of the major crops being affected by abiotic stress; left bottom: drought affected land; left middle: saline land near the natural salt water lake - Sambhar lake in Rajasthan, India. Right panel shows (in sequence from the top) stomata from the rice leaf under salinity stress; microarray image from a rice array showing transcriptome alterations under stress; 2-dimensional electrophoresis (2-DE) gel showing proteome of a salt stressed rice plant; beta glucuronidase (GUS) stained flower of Brassica plant transformed with uidA gene showing its transgenic nature. Courtesy of Sneha Pareek, Anil Singh and Ashwani Pareek.*

*Printed on acid-free paper*

All Rights Reserved

© 2010 Springer Science+Business Media B.V.

No part of this work may be reproduced, stored in a retrieval system, or transmitted in any form or by any means, electronic, mechanical, photocopying, microfilming, recording or otherwise, without written permission from the Publisher, with the exception of any material supplied specifically for the purpose of being entered and executed on a computer system, for exclusive use by the purchaser of the work.



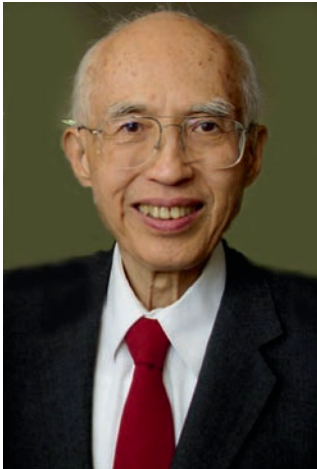

## **Professor Ray J. Wu**

(August 14, 1928 – February 10, 2008)

*Born in China and educated in the USA, Ray Wu spent most of his time at Cornell University, Ithaca, New York. He was an outstanding biochemist, who recognized the significance of DNA engineering, and was one of the first to develop DNA sequencing and recombinant DNA methods. His major work was in rice biotechnology and his vision was to feed the world with high yielding, insect resistant and drought tolerant plants. His other interests have exceeded his work as a scientist and he served as an ambassador for advancing international collaborations and understanding.*

*We dedicate this book to Ray J. Wu as a token of our appreciation and respect for him and his achievements.*

# Contents

<b>Contents</b>	vii
<b>Preface</b>	xv
<b>Contributors</b>	xix
<b>The Editors</b>	xxiii
<b>Author Index</b>	xxvii
<b>Color Plates</b>	xxix
<b>1 Abiotic Tolerance and Crop Improvement</b>	<b>1</b>
<i>Subrahmaniam Nagarajan and Shantha Nagarajan</i>	
I Introduction	2
II Types of Abiotic Stress in Plants	3
III High Temperature Stress	3
IV Cold and Frost Stress	6
V Water Deficit Stress	7
VI Water Logging Stress	8
VII Soil-Related Stresses	9
VIII Climate Change and Stress in Plants	10
IX Conclusions	11
Acknowledgements	11
References	11
<b>Part I: Stress Perception and Signal Transduction</b>	
<b>2 Sensors and Signal Transducers of Environmental Stress in Cyanobacteria</b>	<b>15</b>
<i>Yu Kanesaki, Dmitry. A. Los, Iwane Suzuki, and Norio Murata</i>	
I Introduction	16
II Potential Sensors and Signal Transducers in Cyanobacteria	17
III Involvement of Two-Component Regulatory Systems in Signal Perception and Transduction during Exposure to Environmental Stress	18
IV Other Potential Sensors and Transducers of Environmental Signals	25
V Conclusions and Perspectives	27
Acknowledgements	27
References	28

<b>3</b>	<b>Stress Signaling I: The Role of Abscisic Acid (ABA)</b>	<b>33</b>
	<i>Christopher D. Rock, Yoichi Sakata, and Ralph S. Quatrano</i>	
	I Introduction	35
	II Initial Perception of the Stress	35
	III ABA Receptors	36
	IV Transduction of the Stress Signal	39
	V Regulation of Abiotic Stresses at the Level of Gene Expression	44
	VI Responses to Temperature Stresses	46
	VII Cross-Talk Between Abiotic and Biotic Stress Responses	49
	VIII Regulation of ABA Metabolism	54
	Acknowledgements	57
	References	57
<b>4</b>	<b>Stress Signaling II: Calcium Sensing and Signaling</b>	<b>75</b>
	<i>Marie Boudsocq and Jen Sheen</i>	
	I Introduction	76
	II Calcium Signals	76
	III Calcium Sensing and Signaling	78
	IV Conclusions	86
	Acknowledgements	86
	References	86
<b>5</b>	<b>Stress Signaling III: Reactive Oxygen Species (ROS)</b>	<b>91</b>
	<i>Mikael Brosché, Saijaliisa Kangasjärvi, Kirk Overmyer, Michael Wrzaczek, and Jaakko Kangasjärvi</i>	
	I Introduction	92
	II ROS Production and Control	92
	III The Perception of ROS	95
	IV Insights from Genetic and Genomic Strategies	97
	V Conclusions	99
	Acknowledgements	99
	References	100
<b>6</b>	<b>A Biotic or Abiotic Stress?</b>	<b>103</b>
	<i>Alexandre Robert-Seilaniantz, Rajendra Bari, and Jonathan D.G. Jones</i>	
	I Introduction	104
	II Biotic Stress Versus Abiotic Stress	105
	III General Stress Response	105
	IV ABA and Jasmonic Acid: Usual Suspects for Interaction	107
	V New Points of Interaction	109
	VI Conclusions	116
	Acknowledgements	117
	References	117

<b>7</b>	<b>Protein Kinases and Phosphatases for Stress Signal Transduction in Plants</b>	<b>123</b>
	<i>Lee Chae, Yong Hwa Cheong, Kyung-Nam Kim, Girdhar K Pandey, and Sheng Luan</i>	
	I Introduction	125
	II Receptor-Like Kinases	125
	III Mitogen Activated Protein (MAP) Kinases and MAPK Cascades	132
	IV Calcium-Activated Protein Kinases	138
	V Protein Phosphatases	145
	VI Conclusions	150
	Acknowledgements	150
	References	150
<b>8</b>	<b>Nitrogen Source Influences Root to Shoot Signaling Under Drought</b>	<b>165</b>
	<i>Jason Q.D. Goodger and Daniel P. Schachtman</i>	
	I Introduction	166
	II Nitrogen Source and Availability Influences Signaling Under Drought	166
	III Charge Balance in the Xylem Accounts for Changes Induced by Nutrition and Drought	169
	IV Ammonium and Nitrate Grown Plants: Changes in Xylem Sap Composition	170
	V Conclusions	172
	Acknowledgements	172
	References	172
<b>Part II: Stress Regulation of Gene Expression</b>		
<b>9</b>	<b>Abiotic Stress Responses: Complexities in Gene Expression</b>	<b>177</b>
	<i>Vaishali Panjabi-Sabharwal, Ratna Karan, Tanveer Khan, and Ashwani Pareek</i>	
	I Introduction	178
	II Signal Transduction Pathways Under Abiotic Stresses	179
	III Resources for Identification of Novel Genes	180
	IV Genomics-based Approaches for Understanding the Response of Plants Towards Abiotic Stresses	182
	V Interactome	192
	VI Future Prospects	194
	Acknowledgements	195
	References	195
<b>10</b>	<b>Promoters and Transcription Factors in Abiotic Stress-Responsive Gene Expression</b>	<b>199</b>
	<i>Kazuo Nakashima and Kazuko Yamaguchi-Shinozaki</i>	
	I Introduction	200
	II Significant ABA-Independent Gene Expression Under Abiotic Stress	201

III	Other ABA-Independent Gene Expression Under Abiotic Stress	206
IV	ABA-Responsive Gene Expression Under Abiotic Stresses	206
V	Other Types of ABA-Dependent Gene Expression Under Abiotic Stresses	209
VI	Conclusions and Future Perspectives	210
	Acknowledgements	211
	References	211
<b>11</b>	<b>Epigenetic Regulation: Chromatin Modeling and Small RNAs</b>	<b>217</b>
	<i>Viswanathan Chinnusamy and Jian-Kang Zhu</i>	
I	Introduction	219
II	Epigenetics	219
III	Abiotic Stress-Induced Epigenetic Changes	230
IV	Conclusions and Perspectives	235
	Acknowledgements	236
	References	236
<b>Part III: Physiology and Metabolism</b>		
<b>12</b>	<b>Ion Homeostasis</b>	<b>245</b>
	<i>Anna Amtmann and Roger Leigh</i>	
I	Introduction	246
II	The Need for Ion Homeostasis in Salt Tolerance	246
III	Essential Components and Parameters of an 'Ion Homeostat'	247
IV	Strategies for Na <sup>+</sup> Homeostasis	251
V	Transporters Involved in Na <sup>+</sup> Homeostasis	253
VI	Conclusions and Outlook	257
	Acknowledgements	259
	References	259
<b>13</b>	<b>Glutathione Homeostasis: Crucial for Abiotic Stress Tolerance in Plants</b>	<b>263</b>
	<i>Bhumesk Kumar, Sneh Lata Singla-Pareek, and Sudhir K. Sopory</i>	
I	Introduction	264
II	Regulation of Biosynthesis, Turnover and Compartmentation of Glutathione	265
III	Uptake and Transport of Glutathione	266
IV	Quantification of Redox Status and its Modulation by Abiotic Stresses	267
V	Changes in Glutathione Homeostasis in Plants Under Abiotic Stresses	267
VI	Protein Oxidation Under Abiotic Stresses	273
VII	Glutathione as Signaling Molecule and Role of Glutaredoxins	273
VIII	Crosstalk and Interaction with Other Biomolecules	276
IX	Conclusions and Perspectives	278
	Acknowledgements	278
	References	278
<b>14</b>	<b>Water Balance and the Regulation of Stomatal Movements</b>	<b>283</b>
	<i>Christophe Belin, Sébastien Thomine, and Julian I. Schroeder</i>	
I	Introduction	284
II	How Does Water Balance Affect Stomatal Movements?	285

III	Mechanism of Stomatal Movements and Its Regulation by Water Balance	288
IV	Genes and Promoters of Interest to Manipulate Stomatal Function in Crop Plants	297
V	Conclusions	297
	Acknowledgements	298
	References	298
<b>15</b>	<b>Responses to Macronutrient Deprivation</b>	<b>307</b>
	<i>Arthur R. Grossman, David Gonzalez-Ballester, Nakako Shibagaki, Wirulda Pootakham, and Jeffrey Moseley</i>	
I	Introduction	309
II	Nitrogen Uptake and Assimilation	309
III	Responses to Sustained Nitrogen Starvation	316
IV	Sulfur Uptake and Assimilation	316
V	Control of Sulfur Starvation Responses	322
VI	Phosphate Uptake and Assimilation	327
VII	Control of Phosphorus Starvation Responses	330
VIII	Conclusions	334
	Acknowledgements	335
	References	335
<b>16</b>	<b>Osmolyte Regulation in Abiotic Stress</b>	<b>349</b>
	<i>Arun Lahiri Majumder, Sonali Sengupta, and Lily Goswami</i>	
I	Introduction	350
II	Osmolytes and their Types	350
III	Regulation of Osmolyte Concentration in Plants: Cell and Organ Level	354
IV	Role of Compatible Solutes/Osmolytes in Other Organisms and Animal Cells	358
V	Mechanism of Action of Osmolytes	361
VI	Unique Osmolytes: Glucosylglycerol/Diphosphoinositols	364
VII	Transgenics with Compatible Solutes for Salinity Stress Tolerance	365
VIII	Conclusions	367
	References	367
<b>17</b>	<b>Programmed Cell Death in Plants</b>	<b>371</b>
	<i>Avijit Das, Maki Kawai-Yamada, and Hirofumi Uchimiya</i>	
I	Introduction	372
II	Anatomy of Cell Death	373
III	Biochemistry of Cell Death	374
IV	Role of Vacuole	375
V	Role of Mitochondrion	375
VI	Role of Chloroplast	376
VII	Signals in Cell Death	377
VIII	Cell Death Regulator	378
IX	Conclusions	379
	References	379

## Part IV: Overcoming Stress

<b>18</b>	<b>Varietal Improvement for Abiotic Stress Tolerance in Crop Plants: Special Reference to Salinity in Rice</b>	<b>387</b>
	<i>Rakesh Kumar Singh, Edilberto Redoña, and Luzminda Refuerzo</i>	
	I Introduction	389
	II The Need for Abiotic Stress-Tolerant Cultivars	389
	III Past Breeding Efforts	390
	IV Limits of Plant Stress Tolerance	392
	V Breeding Salinity Tolerance with High Yield	393
	VI The Concept of Heritability	394
	VII Genetics of Salt Tolerance	396
	VIII Breeding Methodology	398
	IX Screening Methodology	401
	X Breeding Strategy to Enhance Salinity Tolerance Through Pyramiding of Mechanisms	405
	XI Testing Approaches for Varietal Adaptability	406
	XII Factors Affecting Salt Tolerance	408
	XIII Collaborative Research	409
	XIV Rice Varieties Developed for Salt Tolerance	410
	XV Impact of Salt-Tolerant Rice Varieties	411
	XVI Conclusions	411
	XVII Recommendations and Future Lines of Research	412
	References	412
<b>19</b>	<b>Transgenic Approaches</b>	<b>417</b>
	<i>Anil K. Singh, Sudhir K. Sopory, Ray Wu, and Sneha L. Singla-Pareek</i>	
	I Introduction	418
	II Transgenic Approaches for Producing Abiotic Stress Tolerant Plants	419
	III Future Perspectives	438
	Acknowledgements	438
	References	438
<b>20</b>	<b>Marker Assisted Breeding</b>	<b>451</b>
	<i>Michael J. Thomson, Abdelbagi M. Ismail, Susan R. McCouch, and David J. Mackill</i>	
	I Introduction	452
	II Molecular Markers as Tools for Dissecting Quantitative Traits	453
	III Case Studies from a Model Crop: MAS for Abiotic Stress Tolerance in Rice	457
	IV Future Perspectives	462
	V Conclusions	465
	Acknowledgements	466
	References	466



<b>21</b>	<b>Stress, Mutators, Mutations and Stress Resistance</b>	<b>471</b>
	<i>Jonathan Gressel and Avraham A. Levy</i>	
	I Introduction-Stress Induced Changes in Mutation Frequency	472
	II Mutator Genes	472
	III Mutators in Stress Resistance – Implications	476
	IV Genetic, Circumstantial and Speculative Evidence for Mutators in Resistance to Stress	477
	V Can Stress Increase the Mutation Frequency to Resistance?	478
	VI Conclusions	480
	Acknowledgements	481
	References	481
<b>22</b>	<b>Systems Biology of Abiotic Stress: The Elephant and the Blind Men</b>	<b>485</b>
	<i>Nina V. Fedoroff</i>	
	I Introduction	486
	II First Responders: Stomatal Guard Cells	487
	III A Systems View of the Stress Response: The Elephant	490
	IV The Future	495
	Acknowledgements	495
	References	495
<b>23</b>	<b>Global Climate Change, Stress and Plant Productivity</b>	<b>503</b>
	<i>Altaf Ahmad, Hema Diwan, and Yash P. Abrol</i>	
	I Introduction	504
	II Elevated Carbon Dioxide	504
	III High Temperature	509
	IV Ultraviolet Radiation	514
	V Tropospheric Ozone	515
	VI Biotic Stress	515
	VII Conclusions and Future Prospects	516
	Acknowledgements	517
	References	517
	<b>Subject Index</b>	<b>523</b>

# Preface

During the past 3 decades, there has been a clear progression in the plant sciences along a trajectory from plant physiology to biochemistry to molecular biology and then towards forward and reverse molecular genetics. The emergence of concepts of genomics has reconciled genome and gene structure with phenotype, thus connecting genetics, through genomics, to plant breeding. We are now in an era of plant biology that begins to integrate all knowledge into a cohesive view of plant life, including the responses of plants to their physical environment. We realize the need for integrating various aspects of plant biology as influenced by environmentally imposed stresses from molecular to field levels. Our book is an attempt to reach this goal.

Plant species, during evolution, have adapted to various edaphic and environmental conditions as dictated by their genetic make-up, while at the same time their genetic systems were shaped and modified during adaptation. In the first approximation, plants are at homeostatic equilibrium where they are found; thus, any deviation from normalcy may then put the species under stress. While some of the plants can sustain growth and reproductive success only within a narrow range of environmental fluctuations, others show flexibility for growing under a wide range of latitudes, tolerating variations in light, temperature, water and nutrient requirement. Due to long-term selection and cultivation under optimal conditions, many genotypes of crop species show either a diminished capacity to adapt to sub-optimal environments, or a diminished ability to sustain growth or to give high yield in response to slight changes. Even mild fluctuations of weather conditions, often coinciding with distinct phases of the crop's life cycle, will be perceived as stress.

Generally, we categorize stress as abiotic or biotic, which constitutes an anthropomorphic distinction that has in the past given rise to many imprecise labels that confused or complicated our understanding of the phenomena. Even when we restrict our view to abiotic stress biology, a collection of questions arise that are equally valid if biotic stresses were in the focus. Of foremost

importance is how plants monitor and identify the type and the intensity of a particular stress. It has been seen that conditions constituting stress for one species may not be stressful for another! In that respect, we would like to know how differences in biochemical or physiological pathways bring about the distinction between species. How do plants respond to a given stress? Are there response pathways that are more conducive to a successful defense against strong stress than others? If so, what is then the molecular basis for a weak or a strong response? What are the molecular events associated with a given stress response? Can we identify molecular markers and molecular events that signify stress and the signature pathways leading to death or to reactions that support survival? How will these markers be different for different stress types and for different species? These are major questions that lead to more detailed discussions having extreme political and ethical ramifications, and general scientific considerations. These are the same questions that students of life sciences and agriculture ask. These are also the questions asked by experts working in these areas of biology.

In this book *Abiotic stress adaptation in plants: physiological, molecular and genomic foundation*, we present a collection of 23 chapters written by 68 experts in the field of plant abiotic stress biology. It is a timely contribution to a topic that is of eminent importance. Answers to questions raised here are required to assure food security, crop yield stability and increased productivity at a time when we are facing a changing global environment. The chapters assembled here provide an up-to-date account of the information available on abiotic stress and the responses by plants.

Due to the importance of this subject, we have placed emphasis on educating beginners in the field of plant stress biology; however, the authors have also provided latest insights in their respective research areas. Due to the relevance of plant stress genetics and molecular biology to global food security well recognized, universities and research institutes across the globe have initiated courses focusing on abiotic stresses, their effects

and tolerance in plants. Courses, on this topic, at undergraduate, graduate and postdoctoral levels, absent just 10 years ago, are now commonplace at several institutions. The authors of this volume have attempted to strike a balance between “in-depth” state of the art knowledge in their respective areas and, at the same time, have provided basic, fundamental information about the topics of their chapters. In several chapters, key information is presented in the form of text boxes as well as instructive figures.

In this book, we present the general principles of abiotic stress responses in plants. An introduction and an overview of abiotic stress, related to agriculture, sets the stage for detailed discussions in four sections.

Section I (7 chapters) deals with *Stress Perception and Signal Transduction* where topics such as sensors and signal transduction pathways as mediated by abscisic acid (ABA), calcium and reactive oxygen species (ROS) are discussed. In addition, protein kinase- and protein phosphatase-mediated signal transduction pathways are presented in this section of the book. Communication between root and shoot under stress conditions, an important though often neglected aspect of the abiotic stress response, is also discussed. With increasing evidence accumulating about stress signaling aspects, the commonalities between plant biotic and abiotic stresses are clearly outlined. Discussion of pathways identify interesting and attractive candidates for genetic modification using several technologies that are aimed at improving stress tolerance in plants.

Section II (3 chapters) deals with *Stress Regulation of Gene Expression*. It is now widely accepted that the regulation of gene expression is the key to survival under stress conditions. New tools and technologies are being used to understand the complexities of stress responses in plants. The discussion about these constitutes one component of this section of our book. Further, this section presents information about promoters and transcription factors as the basis for amplifying signal-based cues and responsible for a given gene expression pattern that organizes the biochemical stress response. In addition to the known genetic regulatory switches controlling gene expression and down-stream response circuits, epigenetic mechanics of gene regulation in plants are also discussed. Transposition events

and chromatin modifications that are related to stress perception and response have been known for some time but only recently, the underlying mechanisms have become clearer. A significant new development that is discussed in this section is the realization of antisense-based control of plant stress responses. An orchestrated and finely tuned functioning of classical gene regulatory mechanisms and microRNA-based control ultimately determines the survival of a plant under stress conditions.

Section III (6 chapters) deals with *Physiology and Metabolism*. Over the years, the plant community has accumulated fairly good information about the physiology and metabolism of plants under stress conditions. These mechanisms include ion homeostasis, regulation of osmolyte synthesis and accumulation, water balance and stomatal movements. The altered physiology, as brought on by a stress, is also reflected in the form of micronutrient deprivation in plants and attempts are being made to understand these responses as well. In addition to research on the known mechanisms of stress responses, efforts are also being made towards understanding roles of relatively understudied pathways, such as glutathione metabolism in its relationship to plants under stress. These aspects along with a discussion of programmed cell death are included in this section of the book.

Section IV (6 chapters) deals with the important aspect of *Conquering Stress*. The ultimate objective of stress biology is to improve crop plants, so that they are able to survive better under changing environmental conditions. This section focuses on various aspects of overcoming stress in plants through breeding, transgenics, and the identification of markers associated with abiotic stresses. Discussion of the evolutionary aspects of various abiotic stresses is also a part of this section. Ultimately, a *Systems Biology* approach is suggested as best suited for making the rapidly emerging, large datasets transparent for an understanding of such complex traits. This last chapter of the book shows us how plant productivity is affected by stresses and how these patterns of changes in environmental factors are being witnessed over the globe.

We are highly thankful to Nausheen Tareen, of Jawaharlal Nehru University, New Delhi, for her valuable help in formatting and incorporating

editorial changes in the manuscripts. Besides her experimental skills, her keen interest and knowledge in the area of abiotic stress has been a great help in editing this book. Inputs received from Drs Sneh L. Singla-Pareek and Dr. Anil K. Singh, of International Center for Genetic Engineering and Biotechnology (ICGEB), New Delhi at the final stages of editing of chapters are also gratefully acknowledged. We are indebted to Noeline Gibson, André Tournois, Jacco Flipsen at Springer

and Manoranjan Mishra at SPi Technologies India Pvt. Ltd. who have been of invaluable help in the production of this book.

We have dedicated this book to Prof. Ray J. Wu, who had completed writing his part in Chapter 19 before his death. We are thankful to Dr. Ajay K. Garg of Cornell University for providing us his photograph shown on the dedication page.

**Ashwani Pareek**

Stress Physiology and Molecular  
Biology Laboratory  
School of Life Sciences  
Jawaharlal Nehru University  
New Delhi 110067, India  
e-mail: ashwanip@mail.jnu.ac.in

**Sudhir K. Sopory**

Plant Molecular Biology  
International Centre for Genetic Engineering  
and Biotechnology  
Aruna Asaf Ali Marg  
New Delhi 110067, India  
e-mail: sopory@icgeb.res.in

**Hans J. Bohnert**

Department of Plant Biology  
and Department of Crop Sciences  
Center for Integrative  
and Evolutionary Genomics  
University of Illinois at Urbana-Champaign  
1201 W. Gregory Drive  
Urbana, IL 61801, USA  
e-mail: bohnerth@life.illinois.edu

**Govindjee**

Departments of Plant Biology and Biochemistry  
Center of Biophysics and Computational  
Biology  
University of Illinois at Urbana-Champaign  
265 Morrill Hall/505 South Goodwin Avenue  
Urbana, IL 61801, USA  
e-mail: gov@life.illinois.edu

# Contributors

**Yash P. Abrol**, Molecular Ecology Laboratory, Department of Botany, Faculty of Science, Jamia Hamdard, New Delhi 110062, India

**Altaf Ahmad**, Molecular Ecology Laboratory, Department of Botany, Faculty of Science, Jamia Hamdard, New Delhi 110062, India

**Anna Amtmann**, Plant Sciences Group, Faculty of Biomedical and Life Science, University of Glasgow, Glasgow G128Q, UK

**Rajendra Bari**, The Sainsbury Laboratory, Norwich Research Park, John Innes Centre, Colney Lane, Norwich, NR4 7UH, UK

**Christophe Belin**, Institut des Sciences du Végétal, Centre National de la Recherche Scientifique, 91198, Gif-sur-Yvette, France

**Hans J. Bohnert**, Department of Plant Biology and Department of Crop Sciences, 192 ERML (E.R. Madigan Laboratory), 1201 W. Gregory Drive, University of Illinois at Urbana-Champaign, Urbana, IL 61801, USA

**Marie Boudsocq**, Department of Molecular Biology, Massachusetts General Hospital and Department of Genetics, Harvard Medical School, Boston, MA 02114, USA

**Mikael Brosché**, Plant Biology Section, Department of Biological and Environmental Sciences, University of Helsinki, FI-00014 Helsinki, Finland

**Lee Chae**, Department of Plant and Microbial Biology, University of California, Berkeley, CA 94720, USA

**Yong H. Cheong**, Department of Bio-Environmental Science, Suncheon National University, Suncheon, Jeonnam 540-742, Korea

**Viswanathan Chinnusamy**, Water Technology Centre, Indian Agricultural Research Institute, New Delhi 110012, India

**Avijit Das**, Division of Biochemistry, Central Rice Research Institute, Cuttack-753 006, Orissa, India

**Hema Diwan**, Molecular Ecology Laboratory, Department of Botany, Faculty of Science, Jamia Hamdard, New Delhi 110062, India

**Nina V. Fedoroff**, Biology Department and Huck Institutes of the Life Sciences, Pennsylvania State University, University Park, PA 16802, USA

**Govindjee**, Department of Plant Biology, University of Illinois at Urbana-Champaign, 265 Morrill Hall, 505 South Goodwin Avenue, Urbana, IL 61801-3707, USA

**David Gonzalez-Ballester**, Department of Plant Biology, The Carnegie Institution, 260 Panama Street, Stanford, CA 94305, USA

**Jason Q.D. Goodger**, School of Botany, The University of Melbourne, Victoria-3010, Australia

**Lily Goswami**, Plant Molecular and Cellular Genetics, Bose Institute, P-1/12, C I T Scheme VII M, Kolkata 700 054, India

**Jonathan Gressel**, Department of Plant Sciences, Weizmann Institute of Science, Rehovot-76100, Israel

**Arthur R. Grossman**, Department of Plant Biology, The Carnegie Institution, 260 Panama Street, Stanford, CA 94305, USA

**Abdelbagi M. Ismail**, Department of Plant Physiology, International Rice Research Institute (IRRI), DAPO Box 7777, Metro Manila, Philippines

**Jonathan D.G. Jones**, The Sainsbury Laboratory, Norwich Research Park, John Innes Centre, Colney Lane, Norwich, NR4 7UH, UK

**Yu Kanesaki**, Bio-Resource Genome Analysis Center, Tokyo University of Agriculture, Sakuragaoka 1-1-1, Setagaya-ku, Tokyo, 156-8502, Japan

**Jaakko Kangasjärvi**, Plant Biology Section, Department of Biological and Environmental Sciences, University of Helsinki, FI-00014 Helsinki, Finland



**Saijaliisa Kangasjärvi**, Plant Physiology and Molecular Biology Section, Department of Biology, University of Turku, FI-20014 Turku, Finland

**Ratna Karan**, Stress Physiology and Molecular Biology Laboratory, School of Life Sciences, Jawaharlal Nehru University, New Delhi 110067, India

**Maki Kawai-Yamada**, Department of Environmental Science and Technology, Saitama University, 255 Shimo-Okubo, Sakura-ku, Saitama 338-8570, Japan

**Tanveer Khan**, Stress Physiology and Molecular Biology Laboratory, School of Life Sciences, Jawaharlal Nehru University, New Delhi 110067, India

**Kyung-Nam Kim**, Department of Molecular Biology, Sejong University, Seoul 143-747, Korea

**Bhumesh Kumar**, Plant Molecular Biology, International Centre for Genetic Engineering and Biotechnology, Aruna Asaf Ali Marg, New Delhi 110 067, India

**Roger A. Leigh**, School of Agriculture, Food and Wine, Waite Campus, University of Adelaide, PMB 1, Glen Osmond -5152, Australia

**Avraham A. Levy**, Department of Plant Sciences, Weizmann Institute of Science, Rehovot-76100, Israel

**Dmitry A. Los**, Institute of Plant Physiology, Russian Academy of Sciences, Botanicheskaya Street 35, 127276, Moscow, Russia

**Sheng Luan**, Department of Plant and Microbial Biology, University of California, Berkeley, CA 94720, USA

**David J. Mackill**, Plant Breeding, Genetics and Biotechnology, International Rice Research Institute (IRRI), DAPO Box 7777, Metro Manila, Philippines

**Arun L. Majumdar**, Plant Molecular and Cellular Genetics, Bose Institute, P-1/12, CIT Scheme VII M, Kolkata, 700054, India

**Susan R. McCouch**, Department Plant Breeding and Genetics, 418 Bradfield Hall, Cornell University, Ithaca, New York 14853, USA

**Jeffrey Moseley**, Department of Plant Biology, The Carnegie Institution, 260 Panama Street, Stanford, CA 94305, USA

**Norio Murata**, National Institute for Basic Biology (NIBB), Myodaiji, Okazaki 444-8585, Japan

**Shantha Nagarajan**, Nuclear Research Laboratory, Indian Agriculture Research Institute, New Delhi 110012, India

**Subrahmaniam Nagarajan**, Protection of Plant Varieties and Farmers' Rights Authority, National Agriculture Science Complex (NASC), Dev Prakash Shastri (DPS) Marg, Pusa Complex, Opposite to Todapur Village, New Delhi 110012, India

**Kazuo Nakashima**, Biological Resources Division, Japan International Research Center for Agricultural Sciences (JIRCAS), Ibaraki 305-8686, Japan

**Kirk Overmyer**, Plant Biology Section, Department of Biological and Environmental Sciences, University of Helsinki, FI-00014 Helsinki, Finland

**Girdhar K. Pandey**, Department of Plant Molecular Biology, University of Delhi South Campus, New Delhi 110021, India

**Ashwani Pareek**, Stress Physiology and Molecular Biology Laboratory, School of Life Sciences, Jawaharlal Nehru University, New Delhi 110067, India

**Wirulda Pootakham**, Department of Biological Sciences, Stanford University, Stanford, CA 94305, USA

**Vaishali Panjabi-Sabharwal**, Stress Physiology and Molecular Biology Laboratory, School of Life Sciences, Jawaharlal Nehru University, New Delhi 110067, India

**Ralph S. Quatrano**, Department of Biological Sciences, Washington University, 1 Brookings Drive Campus, Box 1137, St. Louis, Missouri, 63130, USA

**Edilberto Redoña**, Plant Breeding, Genetics and Biotechnology Division, International Rice Research Institute, Los Baños, Philippines

**Luzminda Refuerzo**, Plant Breeding, Genetics and Biotechnology Division, International Rice Research Institute, Los Baños, Philippines

**Alexandre Robert-Seilaniantz**, The Sainsbury Laboratory, Norwich Research Park, John Innes Centre, Colney Lane, Norwich, NR4 7UH, UK

**Christopher D Rock**, Department of Biological Sciences, Texas Tech University, Lubbock, TX 79409-3131, USA

**Yoichi Sakata**, Department of Bio-Science, Laboratory of Plant Genetics, Tokyo University of Agriculture, Tokyo 156-8502, Japan

**Daniel P. Schachtman**, Donald Danforth Plant Science Center, 975 N. Warson Rd., St. Louis, MO 63132, USA

**Julian I. Schroeder**, Division of Biological Sciences, Cell and Developmental Biology Section, University of California San Diego, La Jolla, CA 92093-0116, USA

**Sonali Sengupta**, Plant Molecular and Cellular Genetics, Bose Institute, P-1/12, C I T Scheme VII M, Kolkata 700 054, India

**Jen Sheen**, Department of Molecular Biology, Massachusetts General Hospital and Department of Genetics, Harvard Medical School, Boston, MA 02114, USA

**Nakako Shibagaki**, Department of Plant Biology, The Carnegie Institution, 260 Panama Street, Stanford, CA 94305, USA

**Anil K. Singh**, Plant Molecular Biology, International Centre for Genetic Engineering and Biotechnology, Aruna Asaf Ali Marg, New Delhi 110 067, India

**Rakesh K. Singh**, Plant Breeding, Genetics and Biotechnology Division, International Rice Research Institute (IRRI), DAPO Box 7777, Metro Manila, Philippines

**Sneh L. Singla-Pareek**, Plant Molecular Biology, International Centre for Genetic Engineering and Biotechnology, Aruna Asaf Ali Marg, New Delhi 110 067, India

**Sudhir K. Sopory**, Plant Molecular Biology, International Centre for Genetic Engineering and Biotechnology, Aruna Asaf Ali Marg, New Delhi 110 067, India

**Iwane Suzuki**, Graduate School of Life and Environmental Sciences, University of Tsukuba, Tennodai, Tsukuba 305-8572, Japan

**Sébastien Thomine**, Institut des Sciences du Végétal, Centre National de la Recherche Scientifique, 91198, Gif-sur-Yvette, France

**Michael J. Thomson**, Plant Breeding, Genetics and Biotechnology Section, International Rice Research Institute (IRRI), DAPO Box 7777, Metro Manila, Philippines

**Hirofumi Uchimiya**, Institute of Molecular and Cellular Biosciences, University of Tokyo, 1-1-1, Yayoi, Bunkyo-ku, Tokyo 113-0032, Japan

**Michael Wrzaczek**, Plant Biology Section, Department of Biological and Environmental Sciences, University of Helsinki, FI-00014 Helsinki, Finland

**Ray Wu (Deceased)**, Department of Molecular Biology and Genetics, Cornell University, 316 Biotechnology Building, Ithaca, NY 14853, USA

**Kazuko Yamaguchi-Shinozaki**, Biological Resources Division, Japan International Research Center for Agricultural Sciences (JIRCAS), Ibaraki 305-8686, Japan

**Jian-Kang Zhu**, Department of Botany and Plant Sciences, University of California, 2150 Batchelor Hall, Riverside, CA 92521, USA



# The Editors



Ashwani Pareek

**Ashwani Pareek** was born in New Delhi, India, in 1969. Currently, he is an Associate Professor of Life Sciences at the Jawaharlal Nehru University (JNU), New Delhi. He obtained his B.Sc. (Botany) and M.Sc. (Plant Molecular Biology) in 1990 and 1992, respectively, from the University of Delhi, India. He was introduced to the exciting field of *Stress Physiology* and *Molecular Biology* of plants during his Master's thesis and his Ph.D. research work under the guidance of Professor Anil Grover at the Department of Plant Molecular Biology, University of Delhi South Campus (UDSC), New Delhi. His research work during Ph.D. focused on the analysis of heat shock proteins (HSPs, especially HSP90) and salt stress proteins (SSPs) in rice. After completing his Ph.D. in 1997, he worked in the laboratory of Professor Ralph S. Quatrano, at the University of North Carolina, Chapel Hill, NC, USA to learn "Advanced Plant Molecular Biology". In 1998, he joined the laboratory of Professor Deepak Pental as a Research Scientist at Delhi University to work on herbicide tolerant *Brassica juncea*. Soon thereafter, he was appointed as a Lecturer at the newly established Guru Gobind Singh Indraprastha University, New Delhi, India, where he played a key role in establishing the School of Biotechnology. After serving this University for 4 years, he was appointed, in 2003, on the faculty of the School of Life Sciences (SLS) at JNU.

The main focus of his research has been towards providing an understanding of the signaling machinery in plants operative under osmotic stresses such as salinity and drought. He uses the tools of functional genomics, transgenics and bioinformatics to dissect out the cascades of events leading to these stress responses in plants, especially the steps involved in "osmosensing". Pareek's honors include: the 2005 Indian National Science Academy (INSA)-Royal Society (UK) exchange visitor's fellowship (to work at the University of Cambridge, UK); the *Boyscast* Fellowship by the Ministry of Science and Technology, Government of India (2001); to work in the laboratory of Professor Hans J. Bohnert) award of "The Rockefeller Foundation" Post-doctoral fellowship (1997) in the area of advanced 'Plant Molecular Biology' as a part of the 'Rice Biotechnology Program' to work in the laboratory of Professor Ralph S. Quatrano.



Sudhir Kumar Sopory

**Sudhir Kumar Sopory** was born in 1948. He received his M.Sc. in 1968 from the Jammu and Kashmir University, India, and his Ph.D. from the University of Delhi, in 1973. In the same year he was appointed as an Assistant Professor at the Jawaharlal Nehru University (JNU), New Delhi; and in 1985, he became a full Professor. In 1997, Sopory joined the International Centre for Genetic Engineering and Biotechnology (ICGEB), also in New Delhi, where he is currently working as a Senior Scientist and the Group Leader of its Plant Molecular Biology division. During his tenure at JNU, he has visited and worked in several laboratories including Max-Planck Institute, Köln, Germany (1976–1978); University of Texas at Austin, USA (1981–1983); Plant Molecular Biology Laboratory, United States Department of Agriculture (USDA), Beltsville, Maryland, USA (1987–1989); and University of Munich, Germany (1991–1992).

Sopory's research involves the understanding of the mechanism of light and stress regulation of gene expression in plants. His earlier work showed an important role of phosphoinositide and protein kinase C signaling in light mediated expression of genes. Currently his research group is looking into the stress signal transduction events and pathways and they are also developing transgenic technology for the production of abiotic stress tolerant plants. His group has identified many novel genes that are regulated in response to salinity and dehydration stress; he has also made major contributions in understanding the mechanism of their induction. His group has also identified a novel role of glyoxalase pathway in stress tolerance. Sopory has published over 170 papers in International Journals, 50 book chapters he has, in addition, edited 8 books.

Sopory has received numerous awards and distinctions including (in chronological order) the Hira Lal Chakravarty Award of the Indian National Science Congress (1986); the Shanti Swarup Bhatnagar Award of the Council of Scientific and Industrial Research (1987); Fellow of Indian Academy of Sciences, Bangalore (1992); Fellow of the Indian National Science Academy, Delhi (1992); Fellow of the National Academy of Sciences, Allahabad (1994); the Birbal Sahni Medal of the Indian Botanical Society (2001); Fellow of the National Academy of Agricultural Sciences (2002); the Tenth Godnev's Award lecture of the Belarus Academy of Sciences (2003); the Birbal Sahni Centenary Gold Medal Award for Lifetime Achievement in Plant Sciences, Indian Science Congress Association (2005); Fellow of the World Academy of Sciences, Trieste (2005); and the highly prestigious *Padma Shri* from the Government of India (2006).



Hans J. Bohnert

**Hans Bohnert** was born in Heilbronn, Germany, in 1944. He is currently Professor of Plant Biology and Crop Sciences at the University of Illinois at Urbana-Champaign (UIUC), Illinois, USA. In addition, he is a faculty member in the Institute for Genomic Biology (IGB) at the UIUC; Director of the Center for Integrative and Functional Genomics, also at the UIUC; visiting Professor at Gyeongsang National University, Jinju, Korea; visiting scientist at Shandong Normal University, Jinan, China; and at King Abdullah University of Science and Technology (KAUST), Jeddah, Saudi Arabia. Bohnert obtained his Staatsexamen, Diploma and Ph.D. (Biology, Chemistry, and Biochemistry) from the University of Heidelberg, Germany. He was a fellow at the European Molecular Biology Laboratory (EMBL), Heidelberg, and at the Max-Planck Institute for Plant Breeding, Cologne, Germany. After habilitation at the University of Düsseldorf, he was a Dozent (Associate Professor) at Duesseldorf, and after 1983 served in the Department of Biochemistry, University of Arizona, Tucson, Arizona, as an Associate Professor and then as a Professor. In addition, he served, during 1995–1997, as a Program Director of the Integrative Plant Biology Program of the US National Science Foundation.

Bohnert's research interests focus on plant abiotic stress genomics, genome structure and gene expression in plants evolutionarily adapted to extreme habitats, and in developing and applying tools for integrating genomics datasets. His honors include Heisenberg-Fellowship awarded by the Deutsche Forschungsgemeinschaft; Research Scientist Award of the College of Agriculture, University of Arizona; and a Senior Research Fellowship by the Smithsonian/Carnegie-Mellon Foundation. He is a Fellow of the American Society of Plant Biology. See Bohnert's web page for further information on him and his research: <http://www.life.illinois.edu/bohnert/>.



Govindjee

**Govindjee** was born in Allahabad, India, in 1932. Since 1999, he has been Professor Emeritus of Biochemistry, Biophysics and Plant Biology at the University of Illinois at Urbana-Champaign (UIUC), Urbana, Illinois, USA. He obtained his B.Sc. (Chemistry and Biology) and M.Sc. (Botany; Plant Physiology) in 1952 and 1954 respectively, from the University of Allahabad. He studied 'Photosynthesis' at the UIUC, under Robert Emerson and Eugene Rabinowitch, obtaining his Ph.D. in 1960, in Biophysics. He served on the faculty of the UIUC for ~40 years, from 1961 to 1999.

Govindjee is best known for his research on the excitation energy transfer, light emission, the primary photochemistry and the electron transfer in "*Photosystem II*" (PS II, water-plastoquinone oxidoreductase). His research, with many collaborators, has included the discovery of a short-wavelength form of chlorophyll (Chl) *a* functioning in the Chl *b*-containing system, now called PS II; of the two-light effect in Chl *a* fluorescence; and of the two-light effect (Emerson Enhancement) in NADP (Nicotinamide Adenine Dinucleotide Phosphate) reduction in chloroplasts. His major achievements include an understanding of the basic relations between Chl *a* fluorescence and photosynthetic reactions; a unique role of bicarbonate on the electron acceptor side of PS II, particularly in the protonation events involving the binding region of the plastoquinone Q<sub>B</sub>; the theory of thermoluminescence in plants; the first picosecond measurements on the primary photochemistry of PS II; and the use of Fluorescence Lifetime Imaging Microscopy (FLIM) of Chl *a* fluorescence in understanding photoprotection, by plants, against excess light.

Govindjee's current focus is on the "*History of Photosynthesis Research*", in '*Photosynthesis Education*', and in the '*Possible Existence of Extraterrestrial Life*'. His honors include: Fellow of the American Association of Advancement of Science (AAAS); Distinguished Lecturer of the School of Life Sciences, UIUC; Fellow and Lifetime member of the National Academy of Sciences (India); President of the American Society for Photobiology (1980–1981); Fulbright Scholar and Fulbright Senior Lecturer; Honorary President of the 2004 International Photosynthesis Congress (Montréal, Canada); the first recipient of the Lifetime Achievement Award of the Rebeiz Foundation for Basic Biology, 2006; Recipient of the Communication Award of the International Society of Photosynthesis Research, 2007; and the Liberal Arts and Sciences Lifetime Achievement Award of the UIUC, 2008. Further, Govindjee was honored in 2007, through two special volumes of *Photosynthesis Research*, celebrating his 75th birthday and for his 50-year dedicated research in 'photosynthesis' (Guest Editor: Julian Eaton-Rye); and in 2008, through a special International Symposium on 'Photosynthesis in a Global Perspective', held in November, 2008, at the University of Indore, India. Govindjee is co-author of '*Photosynthesis*' (John Wiley, 1969); and editor of many books, published by several publishers including Academic Press and Kluwer Academic Publishers (now Springer). See Govindjee's web page for further information: <<http://www.life.uiuc.edu/govindjee>>.

# Author Index

- Abrol, Y.P., 503–517  
Ahmad, A., 503–517  
Amtmann, A., 245–259
- Bari, R., 103–117  
Belin, C., 283–298  
Boudsocq, M., 75–86  
Brosché, M., 91–99
- Chae, L., 123–150  
Cheong Yong, H., 81–83, 123–150, 495  
Chinnusamy, V., 217–236
- Das, A., 371–379  
Dewan, H., 503–517
- Fedoroff Nina, V., 38, 51, 485–495
- Gonzalez-Ballester, D., 307–335  
Goodger Jason, Q.D., 165–172  
Goswami, L., 349–367  
Gressel, J., 471–481  
Grossman, A.R., 307–335
- Ismail, A., 451–466
- Jones, J.D.G., 471–481
- Kanesaki, Yu, 15–27  
Kangasjarvi, J., 91–99  
Kangasjarvi, S., 91–99  
Karan, R., 177–195  
Kawai-Yamada, M., 371–379  
Khan, T., 177–195  
Kim, K.-N., 123–150  
Kumar, B., 263–278
- Leigh, R.A., 245–259  
Levy, A.A., 471–481  
Los, D.A., 15–27  
Luan, S., 123–150
- Mackill, D.J., 307–335  
Majumdar, A.L., 349–367  
McCouch, S.R., 451–466  
Moseley, J., 307–335
- Murata, N., 15–27, 361
- Nagarajan, S., 3–13, 516  
Nakashima, K., 199–211, 373, 426
- Overmyer, K., 91–99, 107, 138
- Pandey, G.K., 36, 37, 46, 82, 85, 123–150, 190, 220, 221, 288, 290, 292, 295, 489  
Pareek, A., 177–195  
Pootakham, W., 307–335  
Punjabi-Sabharwal, V., 177–195
- Quatrano, Ralph S., 33–57
- Redona, E., 387–412  
Refuezo, L., 387–412  
Robert-Seilaniantz, A., 103–117  
Rock, C.D., 33–57
- Sakata, Y., 33–57  
Schachtman, D.P., 165–172  
Schroeder, J.I., 283–298  
Sengupta, S., 349–367  
Sheen, J., 75–86  
Shibagaki, N., 307–335  
Singh, A.K., 11, 353, 387–412, 417–438, 458, 509  
Singh, R.K., 387–412  
Singla-Pareek, S.L., 263–278, 417–438  
Sopory, S.K., 263–278, 417–438  
Suzuki, I., 15–27, 35, 44, 52, 54, 57, 149, 316, 419
- Thomine, S., 283–298  
Thomson, M.J., 451–466
- Uchimiya, H., 371–379
- Wrzaczek, M., 91–99  
Wu, R., 417–438
- Yamaguchi-Shinozaki, K., 45, 107, 108, 189, 199–211, 219, 361, 425
- Zhu, J.-K., 217–236

# Color Plates



*Fig. 1.* Excess irrigation-induced salinity and the crust of salts on the top soil (FAO Photo Gallery). *See Chapter 1, p 9.*

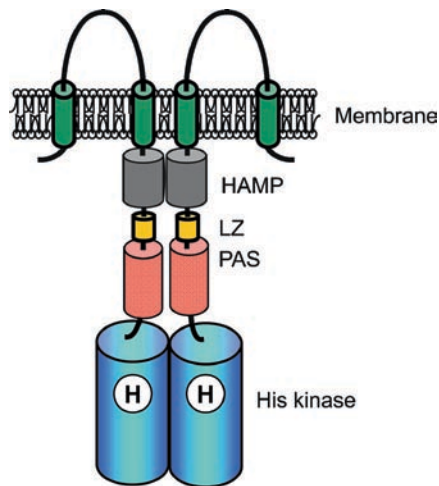

*Fig. 2.* Schematic presentation of the dimeric structure of Hik33 and its interactions with the cell membrane. A decrease in temperature stiffens the membrane leading to a compression of the lipid bilayer, which forces membrane-spanning domains to come closer to each other, changes the linker conformation and finally causes autophosphorylation of histidine kinase domains. Abbreviations: HAMP – hepcidin antimicrobial peptide linker domains; LZ – leucine zipper domains; PAS – PER ARNT SIM domains containing amino acid motifs Per, Arnt, Sim and phytochrome; and Hik – histidine kinase domain. H in circles represent the histidine residues that can be phosphorylated in response to cold stress (Adapted from Murata and Los (2006)). *See Chapter 2, p 21.*



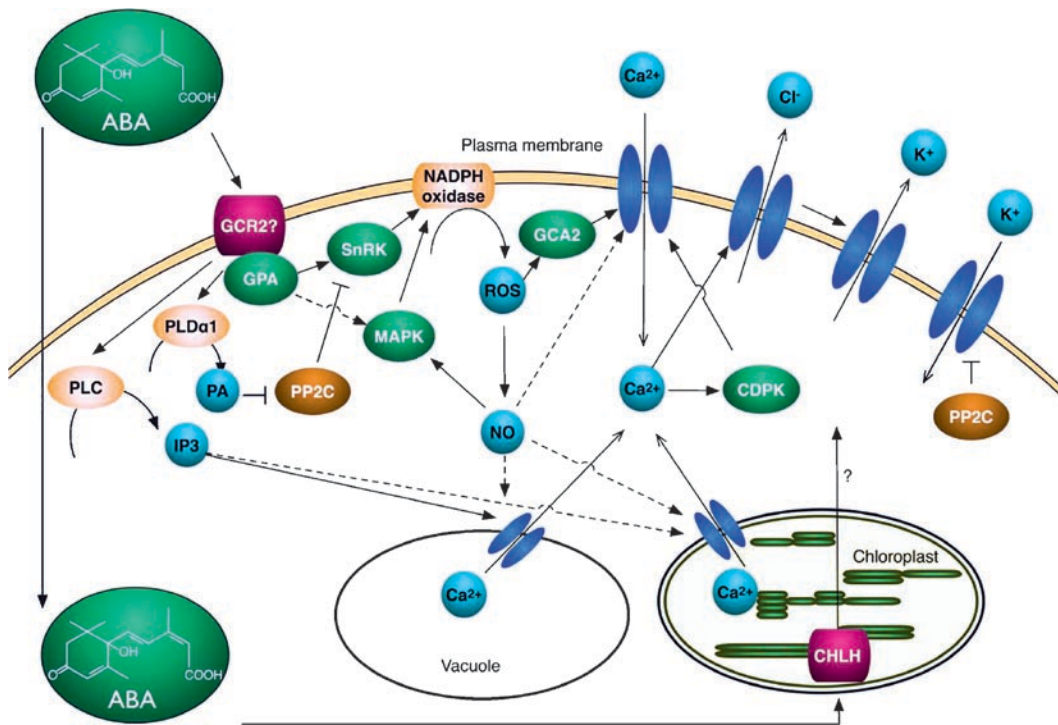

Fig. 3. Schematic illustration of Abscisic Acid (ABA) signaling in stomatal closure. Arrows indicate positive or negative interactions between the factors. Dashed arrows indicate possible regulation. See Chapter 3, p 40.

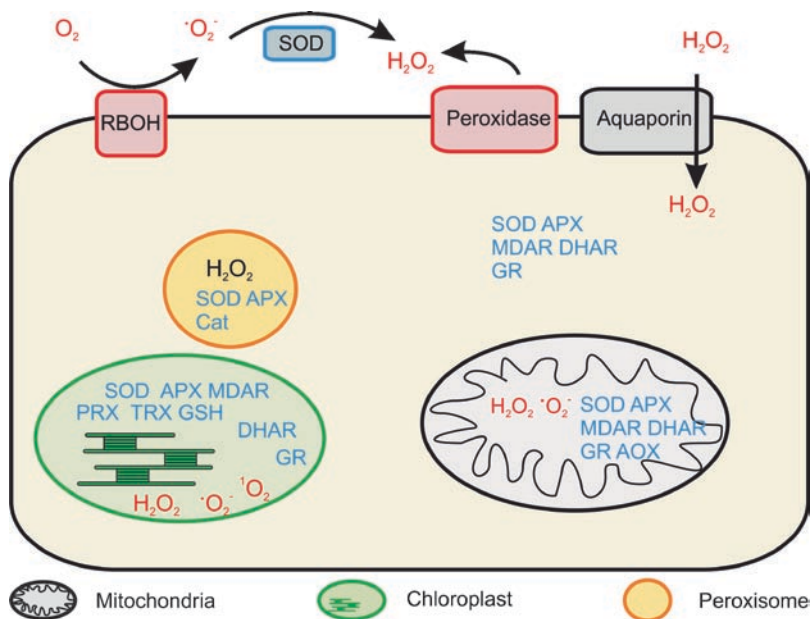

Fig. 4. Sites of reactive oxygen species (ROS) production and enzymatic ROS scavengers. Scavengers are indicated by grey letters. Abbreviations: SOD – superoxide dismutase; APX – ascorbate peroxidase; MDAR – monodehydroascorbate reductase; DHAR – dehydroascorbate reductase; GR – glutathione reductase; CAT – catalase; AOX – alternative oxidase; PRX – peroxidase; TRX – thioredoxin. See Chapter 5, p 93.



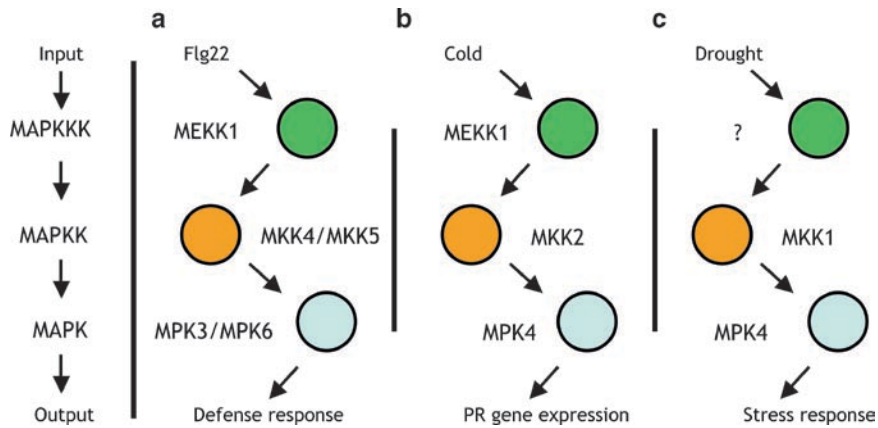

Fig. 5. Mitogen Activated Protein Kinase (MAPK) signaling cascades play pivotal intermediary roles in many plant responses to environmental stress. (a) The MEKK1-MKK4/MKK5-MPK3/MPK6 pathway is known to be involved in transducing the pathogen-related signal initiated by the flagellin peptide, flg22; (b) MEKK1 is also involved in the cold-activated expression of pathogen-resistance genes, through the MEKK1-MKK2-MPK4 pathway; (c) during the response to drought, a MAPK cascade involving MKK1 and MPK4 is constructed, although the identity of the upstream MAPKKK remains unknown. See Chapter 7, p 135.

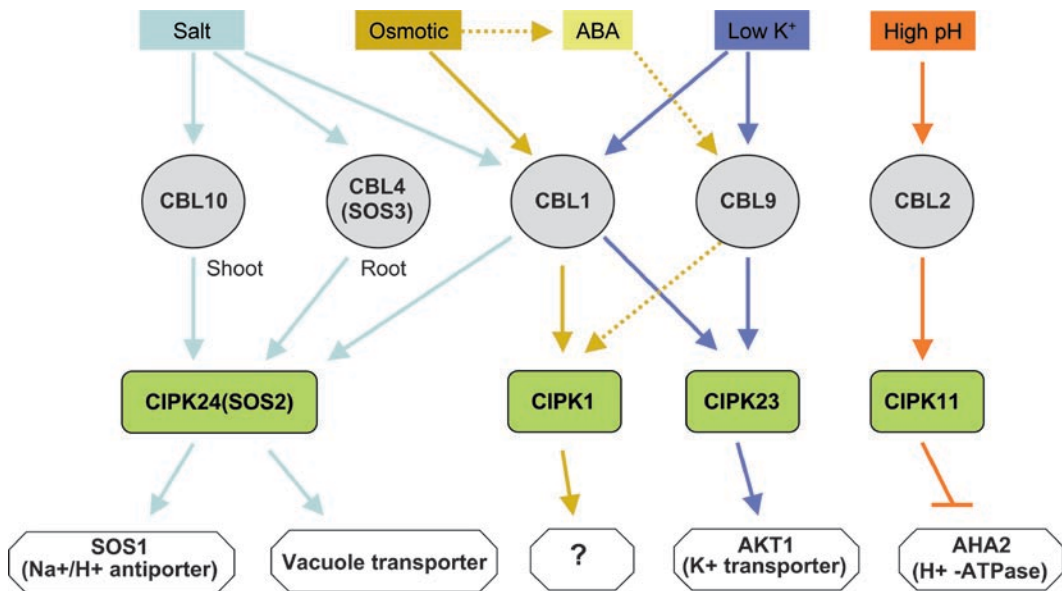

Fig. 6. The Calcineurin B-like protein (CBL) calcium sensor and CBL-interacting protein kinase (CIPK) signaling network is involved in various abiotic stress responses. Based on the results of genetic and molecular analyses, the model depicted above was proposed. The different line colors indicate different stress signaling pathways. See Chapter 7, p 143.

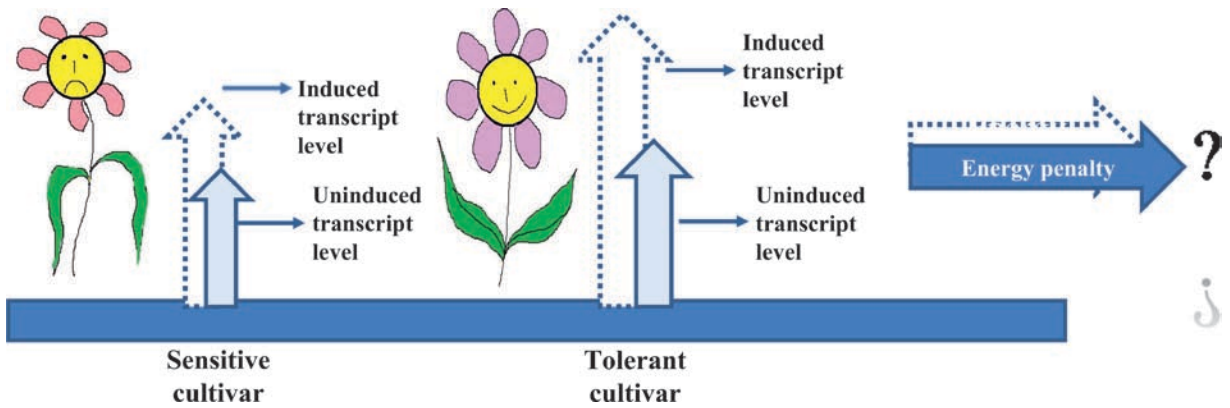

Fig. 7. Preparedness of the tolerant cultivar by maintenance of relatively higher level of transcripts of stress related genes. See Chapter 9, p 181.

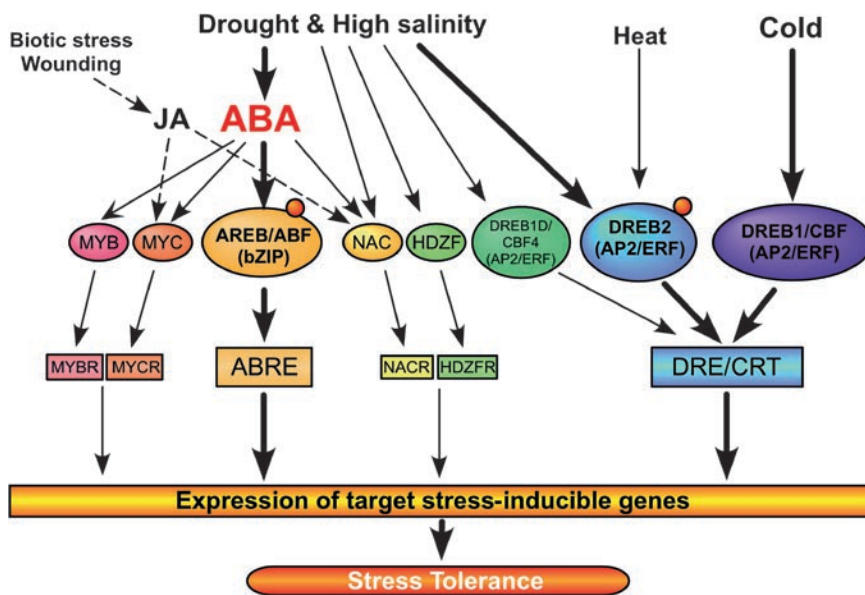
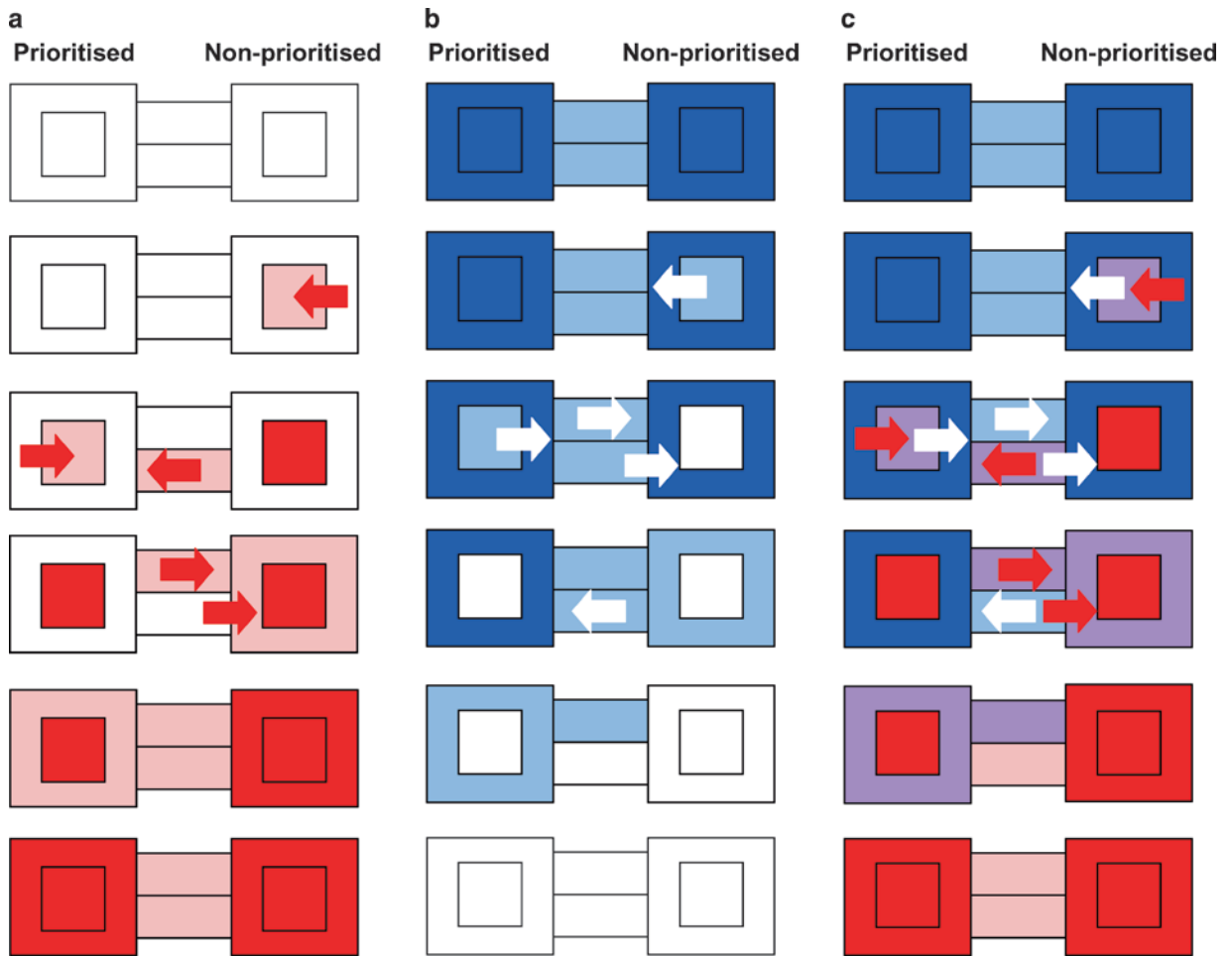
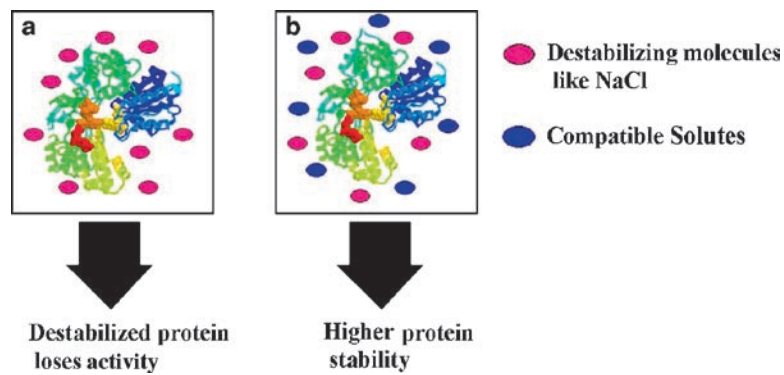

Fig. 8. Transcriptional regulatory networks of *cis*-acting elements and transcription factors involved in abiotic-stress-responsive gene expression in *Arabidopsis*. Transcription factors controlling stress-inducible gene expression are shown in ellipses. *cis*-acting elements involved in stress-responsive transcription are shown in boxes. Small filled circles reveal modification of transcription factors in response to stress signals for their activation, such as phosphorylation. See Chapter 10, p 201.



*Fig. 9. (a) Predicted dynamic behaviour of the telescope model during salt stress; (b) K<sup>+</sup>-deficiency stress; (c) and combined stress. For simplicity only the collective cellular components of the model, presented in Fig. 12.3, are shown. Stress progresses from top to bottom either in time or strength. Colors indicate high (red for Na<sup>+</sup> and blue for K<sup>+</sup>), low (white) or changing ion concentrations (pink for Na<sup>+</sup> accumulation, light blue for K<sup>+</sup> depletion). Arrows indicate the movement of Na<sup>+</sup> (red) and K<sup>+</sup> (white) that is most crucial for the homeostatic behaviour of the system at a given stage of the stress. c is a simple overlay of a and b with K<sup>+</sup>/Na<sup>+</sup> ratios being high (blue), low (red) or intermediate (purple). During early (mild) stress, homeostasis is achieved by making use of cellular reservoirs in non-prioritized tissues. If the stress persists cellular reservoirs in prioritized tissues are exploited to maintain homeostasis in both tissue types. Only when both resources are exhausted cellular spaces will start changing. However, homeostatic control at the whole-plant level assures that this happens first in non-prioritized tissues. See Chapter 12, p 258.*



*Fig. 10. Diagram illustrating the function of compatible solutes. (a) Lack of compatible solutes results in the preferential binding of destabilizing molecules like NaCl to the protein surface, leading to degradation; (b) Presence of compatible solutes preferentially excludes the binding of destabilizing molecules and stabilizes native protein conformation (Modified from Mundree et al. 2002). See Chapter 16, p 362.*

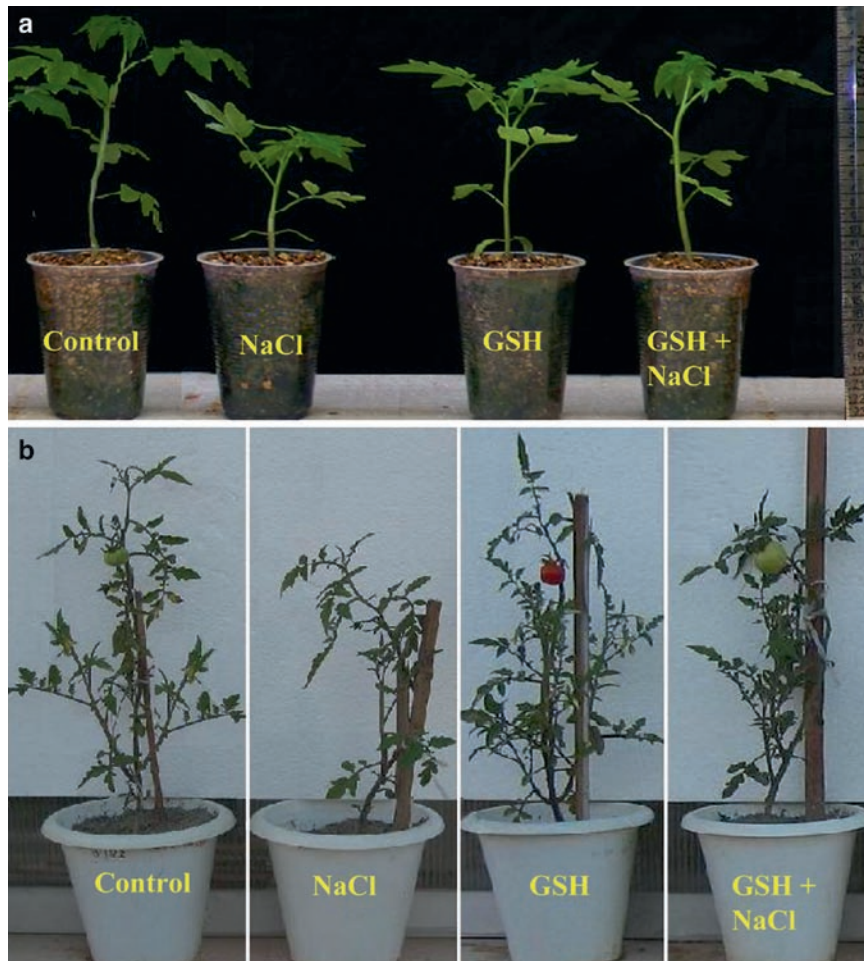

Fig. 11. Salinity stress and reduced glutathione (GSH). Effect of exogenous application of NaCl (200 mM) and/or GSH (2 mM) on tomato plants as seen on (a) growth and (b) fruiting of plants in pot culture. See Chapter 13, p 269.

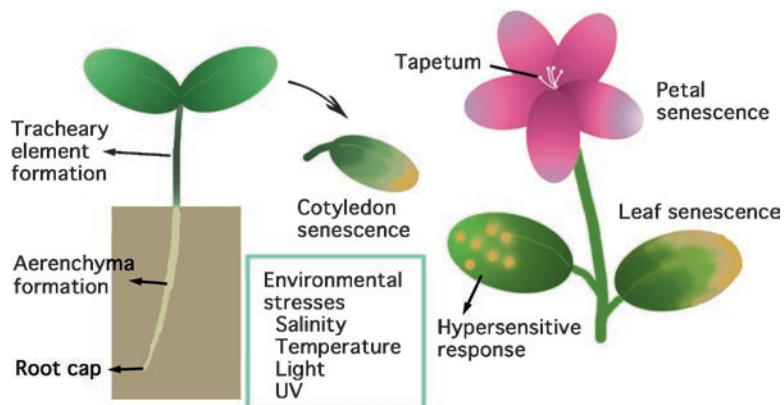

Fig. 12. PCD occurs in plant life cycle. PCD is involved in many phases through vegetative and reproductive development and response to environmental stresses. See Chapter 17, p 373.



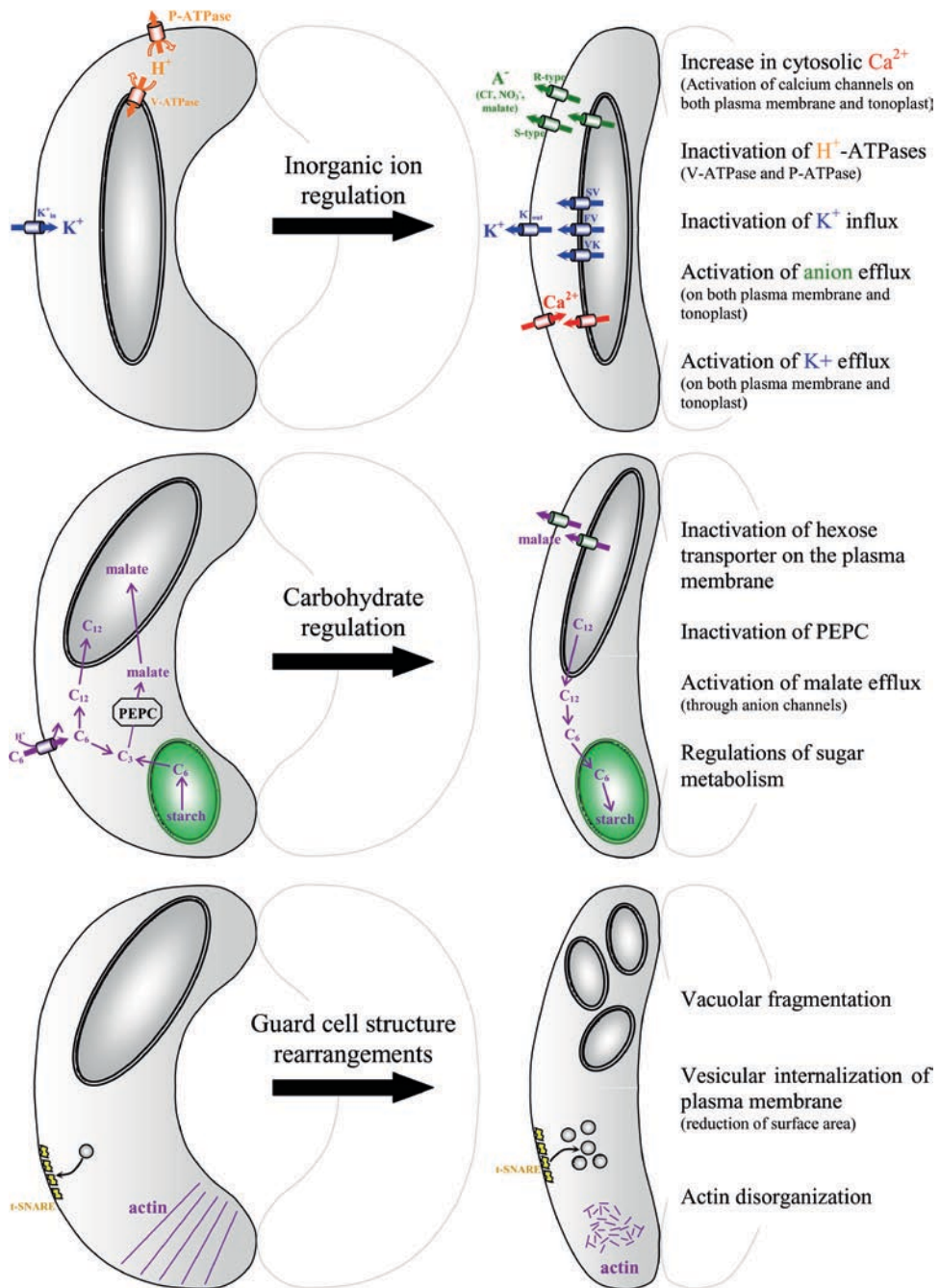

Fig. 13. Mechanisms of Abscisic Acid (ABA)-induced stomatal closure. The regulation of inorganic ion concentration and carbohydrate content in guard cells trigger the decrease in osmotic pressure and a massive water efflux. Concomitantly, structural rearrangements facilitate stomatal closure. See Chapter 14, p 289.

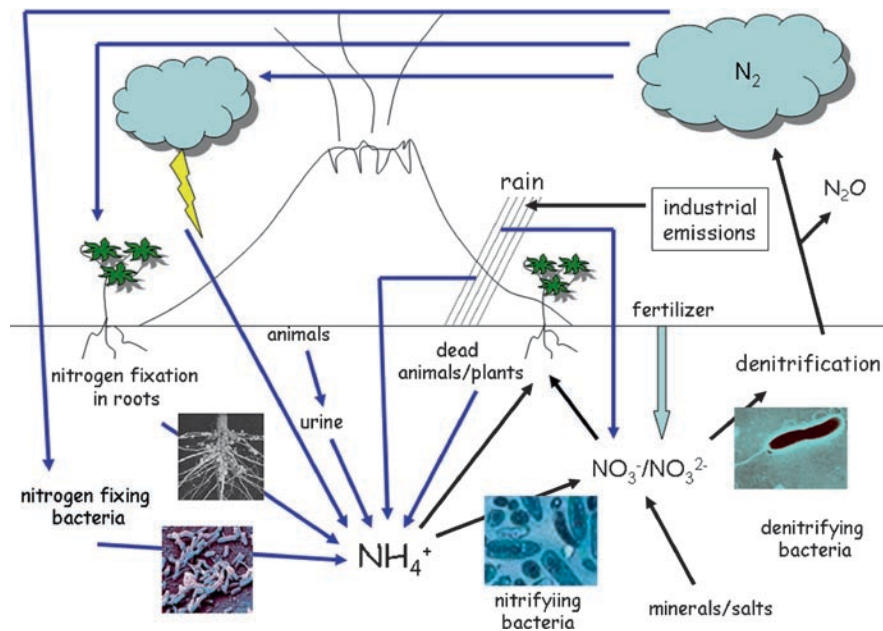

Fig. 14. Nitrogen cycle. Generally,  $\text{NO}_3^{2-}$  is the major form of nitrogen in the environment; although  $\text{NH}_4^+$  and  $\text{NO}_2^-$  can be present at significant levels as well (high  $\text{NH}_4^+$  levels are often toxic to organisms). As indicated,  $\text{NH}_4^+$  can be generated from  $\text{N}_2$  through the action of animal metabolism, lightning, volcanic activity and  $\text{N}_2$  fixation. The fixation of  $\text{N}_2$  can be performed by either free-living bacteria or bacteria associated with the nodules of leguminous plants.  $\text{NH}_4^+$  can be oxidized through the action of nitrifying bacteria, which use ammonia monooxygenase to oxidize ammonia to hydroxylamine ( $\text{NH}_2\text{OH}$ ) and then nitrite oxidoreductase to oxidize  $\text{NO}_2^-$  to  $\text{NO}_3^-$ . Oxides of nitrogen can be converted to  $\text{N}_2$  by denitrification, an anaerobic process performed by specific bacteria (Modified from <http://telstar.ote.cmu.edu/enviro/m3/s4/graphics/embedded/nitronodules.gif>; [http://www.markergene.com/WebNewsletter7.4\\_files/image007.gif](http://www.markergene.com/WebNewsletter7.4_files/image007.gif); <http://www.anoxkaldnes.com/Bilder/jpg/RD7.jpg>; [http://staffwww.fullcoll.edu/tmorris/elements\\_of\\_ecology/images/bacteria\\_denitrifying.jpg](http://staffwww.fullcoll.edu/tmorris/elements_of_ecology/images/bacteria_denitrifying.jpg)). See Chapter 15, p 310.

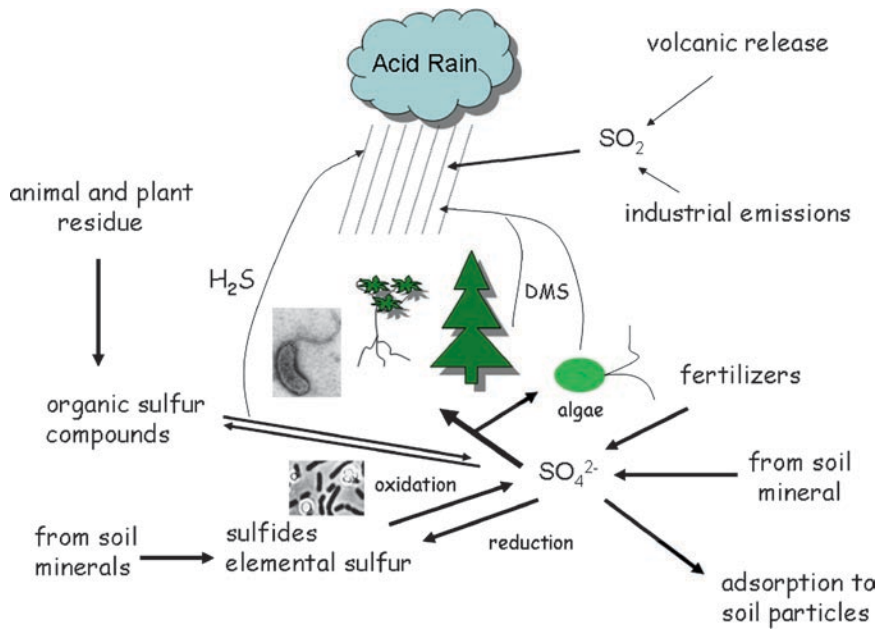

Fig. 15. Sulfur cycle. The most abundant form of sulfur in the environment is  $\text{SO}_4^{2-}$ , although certain environments can have high levels of sulfides ( $\text{H}_2\text{S}$ ) and elemental sulfur ( $\text{S}^0$ ).  $\text{SO}_4^{2-}$  can be reduced by plants and bacteria in a reductive assimilatory process (to make cysteine methionine and glutathione). The formation of  $\text{H}_2\text{S}$  often occurs as a result of bacterial break down of organic matter in the absence of oxygen (major process in swamps and sewers). DMSP or dimethylsulfoniopropionate  $[(\text{CH}_3)_2\text{S}^+\text{CH}_2\text{CH}_2\text{COO}^-]$  is produced by marine phytoplankton, seaweeds and some terrestrial and aquatic vascular plants. There are two major volatile breakdown products of DMSP, methanethiol ( $\text{CH}_3\text{SH}$ ), which can be assimilated by bacteria into protein sulfur, and DMS or dimethyl sulfide ( $\text{CH}_3\text{SCH}_3$ ), which is released into the atmosphere and plays a key role in cloud formation; methanethiol can also be converted to DMS. Furthermore, a number of bacteria and archaea can oxidize inorganic sulfur compounds such as  $\text{H}_2\text{S}$  (toxic to most organisms) and  $\text{S}^0$  and use the electrons for growth (Modified from <http://www.bio.ku.dk/nuf/images/C.limicola.LM.jpg>; <http://www.princeton.edu/~chm333/2004/Bioremediation/images/Desulfovibrio>). See Chapter 15, p 311.



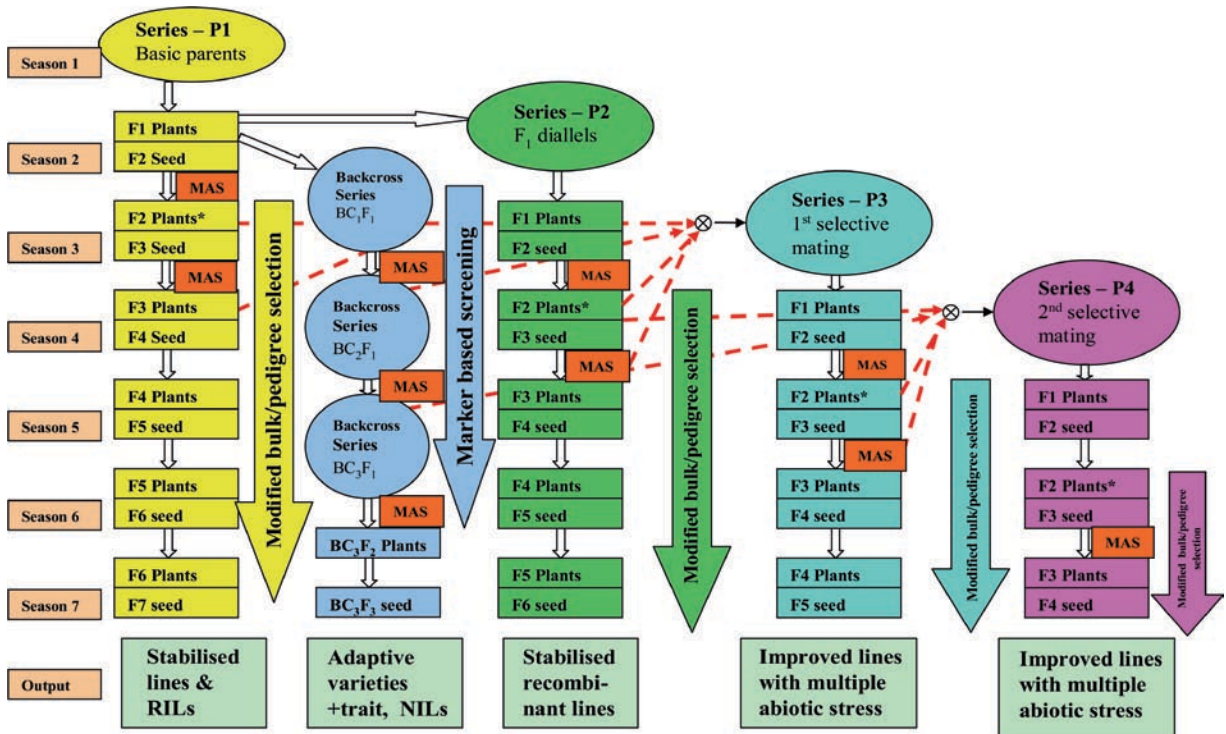

Fig. 16. Schematic diagram of the modified diallel selective mating system (DSMS) involving marker-assisted selection (MAS) adapted from Singh et al. 2008). See Chapter 18, p 400.

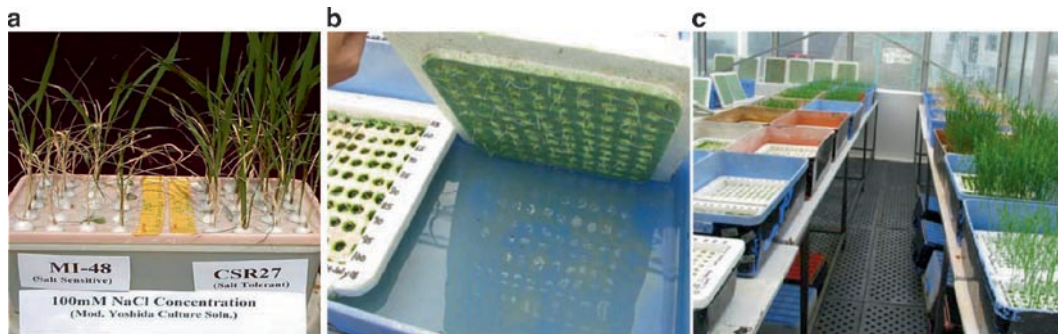
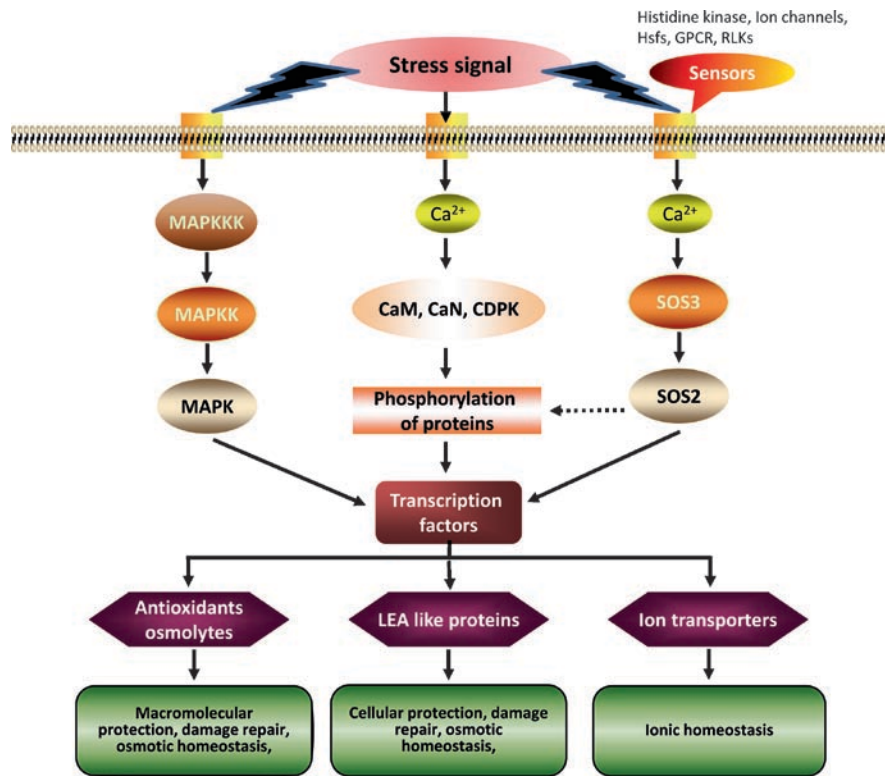

Fig. 17. Nutrient culture solutions based on seedling stage screening system for salinity tolerance in rice: (a) breadbox with perforated lid; (b) floats with holes and nylon mesh; and (c) pregerminated seeds placed in floats. See Chapter 18, p 402.



*Fig. 18.* Signal transduction pathways involved in abiotic stress responses. Stress signal is perceived through sensor(s) and the signal is transduced to the intracellular targets. Hyperosmolarity caused due to salinity and drought stress activates MAPK cascade which serves as a link between upstream receptors and downstream signaling components such as transcription factors to induce cellular response. Abiotic stress signal also initiates  $\text{Ca}^{2+}$  signal that causes activation of  $\text{Ca}^{2+}$ -binding proteins, such as CaM, CaN and CDPK. These  $\text{Ca}^{2+}$ -binding proteins phosphorylate and activate the transcription factors, which mediate cellular responses.  $\text{Ca}^{2+}$  signal also induces the salt overly sensitive (SOS) signaling pathway which is required for ion homeostasis. See Chapter 19, p 421.



*Fig. 19. (a)* Performance of *Sub1* introgression lines under field conditions. Fourteen day old seedlings were transplanted in the field and completely submerged 14 days later, for a period of 17 days. Photo was taken about 2 months after desubmergence. (1) IR64, (2) IR64-Sub1, (3) Samba Mahshuri, (4) Samba Mahshuri-Sub1, (5) IR42 (sensitive check) and (6) IR49830 (tolerant, used as *SUB1* donor) (Photo courtesy of IRRI); *(b)* a rice farmer and his wife showing the performance of their local variety (*right*) and an improved salt tolerant breeding line (*left*) in a highly alkaline soil in Faizabad district, Uttar Pradesh, India (Photo by A. Ismail taken on Oct. 7, 2007). See Chapter 20, p 459.



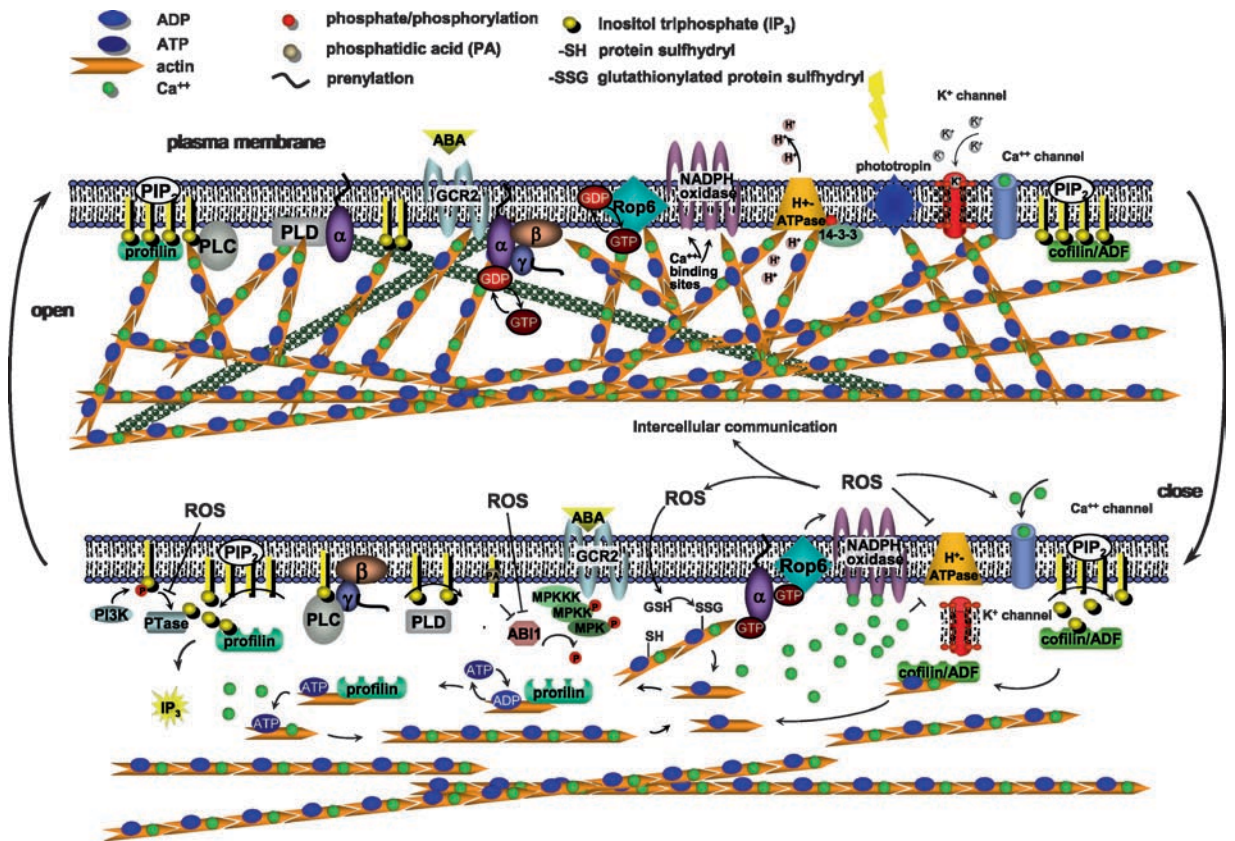

Fig. 20. A diagrammatic representation of some of the changes known to occur in the structural and signaling components during stomatal movements, as described in the text. Abbreviations (used in the figure): ABA, abscisic acid;  $\alpha\beta\gamma$ , heterotrimeric G-protein subunits; GCR2, G-protein coupled receptor 2; PIP<sub>2</sub>, phosphatidylinositol 4,5 bisphosphate; GSH, glutathione; MPK, MAP kinase; MPKK, MAPK kinase; MPKKK, MAPKK kinase; PLC and PLD, phospholipases C and D; ROS, reactive oxygen species. See Chapter 22, p 492.

# Chapter 1

## Abiotic Tolerance and Crop Improvement

Subrahmaniam Nagarajan\*  
*Protection of Plant Varieties and Farmer's Rights Authority,  
National Agriculture Science Complex (NASC), Dev Prakash Shastri (DPS)  
Marg, Pusa Complex, Opposite to Todapur Village,  
New Delhi 110012, India*

Shantha Nagarajan  
*Nuclear Research Laboratory, Indian Agriculture Research Institute,  
New Delhi 110012, India*

Summary .....	2
I Introduction.....	2
A Hunter Evolves as Collector and Cultivator .....	2
B Projected Food Demands.....	3
C What Does Stress Mean to an Agriculturalist?.....	3
II Types of Abiotic Stress in Plants .....	3
III High Temperature Stress.....	3
A Temperature Periodicity .....	4
B Temperature-Induced Male Sterility.....	4
C High Temperature and Heat Stress .....	4
D Impact on Quality of the Harvest.....	5
IV Cold and Frost Stress .....	6
V Water Deficit Stress .....	7
A Effect on Root Pattern .....	7
B Effect on Development .....	7
C Effect on Fertility Status .....	8
D Tolerance to Moisture Stress.....	8
VI Water Logging Stress .....	8
A Flood Tolerance in Rice .....	8
1 Role of Root Aerenchyma.....	9
B Effect on Fruit Crops.....	9
VII Soil-Related Stresses.....	9
A Impact on Soil Microbes .....	10
VIII Climate Change and Stress in Plants.....	10
IX Conclusions .....	11
Acknowledgements .....	11
References .....	11

---

\* Author for Correspondence, e-mail: drsnagarajan@gmail.com/subrahmaniam@nagarajans.net; shantha@nagarajans.net

## Summary

'In a world that has the means for feeding its population, the persistence of hunger is a scandal' (Food and Agriculture Organization 2006). This is a very comprehensive statement made by the United Nations Organization and clearly explains the present state of apathy of world agriculture. While plant physiological investigations provide knowledge and better understanding of the effects of abiotic stress on plants, crop physiology provides information on how stress affects plant growth, and eventually agricultural yield. Growing global demand for food and feed of various plant-based products, climatic change-imposed stress on agriculture and the new opportunities, such as the advances in molecular biology, are covered in this chapter. The extent of crop yield loss due to abiotic stresses can be reduced by manipulating plant metabolism, and use of genetically-engineered plants. This chapter provides readers with a broad overview of the various types of abiotic stresses and their influence on the yields of economically important crops such as cereals, grain legumes, vegetable crops, oilseed crops, forage crops and medicinal crops (Rai and Takabe 2006).

Keywords abiotic stress • heat • cold • drought • water logging • salinity • climate change

## I Introduction

Crop cultivation involves growing a population of plants under good care and management. Genetic yield potential of a crop variety is not always attained, as it is limited by factors such as the non-availability of timely inputs, inappropriate growing season, outbreak of pests and abiotic stresses. Type of abiotic stress differs with the soil in which it is grown, the crop growing season, the crop in question and the geographic location. Some of the most common abiotic stresses are wide fluctuation in the environmental conditions, soil moisture availability, high evaporation, inundation of the field, atmospheric temperature, periodicity variations, frost and cold injury, soil physico-chemical status, non-availability of nutrients and heavy metal toxicity. Understanding the physiological basis of such stresses, their genetic basis of tolerance, gene manipulation and mitigating the stresses agronomically, are some of the available technological options.

### A *Hunter Evolves as Collector and Cultivator*

Man has hunted and tamed animals since times immemorial. He selected, collected and domesticated edible plants for food and feed for his animals.

---

*Abbreviations:* AM—arbuscular mycorrhizae; FAO—Food and Agriculture Organization of the United Nations; GHGs—green house gases; VAM—vascular arbuscular mycorrhizae

Gradually, the hunter developed the art of growing plants and domesticated animals to ensure a sustained food supply. It was not an easy job, as domesticated wild plant tribes, when grown as a population, resulted in genetic vulnerability and was prone to the uncertainties of weather (abiotic) or pest and pathogen (biotic) damage. Early farmers constantly improved the quantity, quality and storability of crop yields that led to development of a narrow genetic base of the varieties. This practice rendered their selections more vulnerable to various abiotic and biotic stresses. Thus, since the beginning of agriculture, man has been confronting and overcoming the various abiotic stresses. In this long ordeal, farmers worldwide selected and domesticated various plants, now grouped as land races, folk varieties and farmer's varieties. And many of these varieties possess genes for tolerance to various abiotic stresses.

Modern high-yielding cultivars, particularly rice and wheat, have greater potential under well managed conditions. The vulnerability of modern crops to abiotic stresses causes wide annual yield fluctuations between bad years and good years. And there is a major global food deficit as the demand for food, and plant based by-products, is higher than what is being produced. Naturally, the blame game is on, attributing the price increase of essential commodities to the globalized agri-trade, changed food consumption patterns, crop failures in Africa and Australia and of course to the surging food demand of emerging economies such as China and India.

## B Projected Food Demands

Abiotic stress, such as drought, flood, problem soils (salinity and alkalinity), extreme temperatures (especially at flowering and maturity times), chemical toxicity and oxidative stress are serious threats to agriculture and the environment. Increased salinity of arable land is expected to have devastating global effects, resulting in 30% land loss within the next 25 years, and up to 50% by the year 2050 (Food and Agriculture Organization 2006).

By 2025, the world farmers would have to produce about 3.0 billion tons of cereals to feed the earth's population of nearly 8.0 billion people. This means that world wide, an average cereal (mainly wheat and rice) yield of 4 t/ha is to be achieved and sustained. Added to this is the demand for feed, vegetables, fruits, fiber, oil, energy and wood. In this book various issues are examined to enable achieving an increase in crop productivity by way of better varieties that are tolerant to various abiotic stresses.

## C What Does Stress Mean to an Agriculturalist?

Stress in biological terms means deviation in the normal physiology, development and function of plants which can be injurious and can inflict irreversible damage to the plant system. The type of stress that crop plants suffer from can be broadly grouped as 'temperature variation at crucial stages'. There are several sticky abiotic parameters revolving around temperature e.g., frost damage and evaporation stress.

Many living organisms parasitize plants, such as the plant pathogenic viruses, bacteria, fungi, nematodes, insects and phanerogamic plants. Abiotic stresses are inflicted by non-living things/matter on which the plant system is dependent. Ambient temperature, relative humidity, sunshine, microclimate, soil nutrition, soil biota and other physico-chemical properties of the soil create stress on plant.

## II Types of Abiotic Stress in Plants

Various types of abiotic stresses that plants encounter between seedling to harvest stages are:

- Unseasonal rain

- Abundant and copious soil moisture or its quick retreat
- Soil salinity
- Micronutrient (soil nutrition) shortage in the root zone
- Global change in weather patterns
- Economic and political uncertainty

In addition, many biotic stresses affect crop yield:

- Disease damage
- Insect or nematode damage
- Invasive threats

Breeding crops for specific abiotic tolerance is one of the core activities of varietal improvement program. Developing abiotic tolerant varieties and adopting good crop practices are the means by which agriculturists minimize the impact of abiotic stresses without causing a substantial yield loss. Abiotic tolerant plants have the inbuilt capacity to overcome the damage caused by stresses at various growth stages. If the abiotic stress is only for a brief period and if congenial conditions return thereafter, then the plant activates the various compensation mechanisms and succeeds in executing damage control. As a consequence, the total biomass and the yield of crops remain largely unaffected.

Often, many of the abiotic stresses occur together and in that process inflict severe yield losses. For example, crop plants are largely dependent on the availability of moisture in the top 10 cm of the soil profile. Drought stress occurs when soil moisture status is low, relative humidity is low and temperature is high. When relative humidity is low and temperature is high i.e., two stresses occur together, 'atmospheric drought' sets in. This is agriculturally overcome by extending irrigation; and where timely access to surface irrigation is not feasible, the 'agricultural drought' sets-in. And if the agricultural drought persists, crops virtually dry up, fires become common and productivity of orchard crops gets badly affected.

## III High Temperature Stress

There are three cardinal points for the types of temperatures that are vital for plant activity:

- Minimum temperature below which no plant growth and development occurs



- Optimum temperature at which maximum plant growth and development occurs
- Maximum temperature above which plant growth and development stops

Temperature requirement of different plants vary for the cardinal points as it is related to the duration of exposure, age of the plant, previous history and such externalities. Generally, it is the air temperature or the ambient temperature that affects the crop in several ways.

### A Temperature Periodicity

Diurnal variation in air temperature is important as it influences photorespiration. The total heat units accumulated during the growth phase of plants influence the physiology, reproduction and maturity of crops. Deviation from normal temperatures or day/night periodicity around reproductive stage influences the seed yield and seed quality. Invariably, short day conditions at pod filling or grain filling stage negatively affect the seed weight and the physico-chemical quality of the seed. In leguminous crops, periodicity pattern influences the root behavior, nodulation patterns and total biomass production. Any temperature deviation due to global weather change is likely to affect the growth and physiology of plants in more than one way.

### B Temperature-Induced Male Sterility

Hybrid rice has tremendously contributed to the productivity gain of rice in several parts of

Asia. Production of hybrid rice seed can be simplified by the availability of two line hybrids. Researchers have been successful in identifying rice lines that carry the *tms* genes, which show complete male sterility and 100% of the pollens turn out to be sterile when exposed to 35.5/23.1°C temperature periodicity at the critical growth stage (i.e., 1–2 week after panicle initiation) (Lopez et al. 2003). This temperature periodicity induced genetic male sterility in rice has opened up new opportunities to produce rice hybrid seeds at an affordable price and at the same time provide productivity gain to the growers.

### C High Temperature and Heat Stress

The sudden increase in ambient maximum temperature, in a matter of few days, by 5–7°C with corresponding increase in the minimum temperature, creates ‘heat stress’ on plants. The normal physiology of the plant gets affected and plant maturity is accelerated. In some cases, plants shed leaf/flower/fruit or dry-up non productive tillers and even become sterile to overcome the unprecedented stress. In practical agriculture, such heat stress inflicts enormous crop losses. Due to global weather change, the frequency of heat stress is predicted to increase in different parts of the world.

Rates of photosynthesis and respiration increase with an increase in temperature until a threshold maximum photosynthesis level is achieved. Generally, it is around 22–24°C

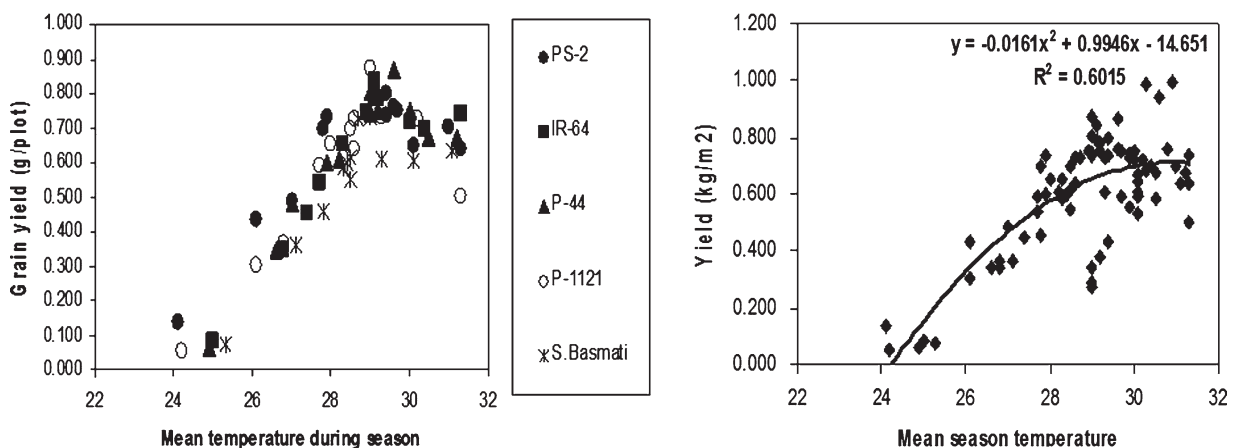

Fig. 1. Relationship of mean season temperature with grain yield of rice cultivars. Mean season temperature above 33°C and below 27°C drastically reduced rice yields both in aromatic and non-aromatic cultivars (Shantha Nagarajan, IARI, New Delhi).



and remains that way, up to 30–32°C. In rice, it was found that grain yields declined if mean seasonal temperature increased above 33°C (Fig. 1). Surpassing the high temperature peak, various enzymes get inactivated, decreasing the photosynthetic efficiency. The high temperature coupled with high respiration and evaporation pushes the plant to permanent wilting when the temperature exceeds 46°C. The extent of crop loss inflicted by heat stress can ruin the income for poor farmers in heat prone areas. In many cases, there may be adequate soil moisture but the negative water balance created by heat stress lead to withering of plants in a matter of few days. Under the natural habitat, plants have been exposed to more than one stress at a time; consequently they have evolved strategies against a combination of stresses by responding to them in different ways. Often high temperature, high transpiration rate and high light intensity occur together affecting the plant productivity (Wardlaw and Wrigley 1994).

Short periods of very high temperature (>35°C) are of common occurrence in many wheat-growing areas of the world. Such sudden exposure to heat stress affects the yield and quality of the wheat grain (Fig. 2). Maturing kernel is highly sensitive to heat stress at milk and dough stages of grain development. The kernel becomes progressively less sensitive as the grain hardens. Reduction in kernel weight results primarily due to the shortening of the grain filling duration than due to the reduction in the rate of grain filling. The grain filling is seriously impaired and translocation processes get affected due to early senescence of

the leaf and ear, and the reduction in chlorophyll content adversely affects photosynthesis. Since the photosynthetic source is affected and the sink duration is reduced, filling of the kernel is poor, resulting in small grain size having less grain weight. Under such situations, alternate sugar sources, stored as stem reserves, get mobilized so as to fill the kernel. It has been well demonstrated in spring wheat cultivars that comparable genotypes differ in grain shriveling under drought and heat stress conditions. This genotypic variation in the mobilization of stored stem reserves to support grain filling is an important consideration in selecting wheat lines for heat tolerance. Also, it is widely acknowledged that in wheat, under heat stress situations, kernel number per spike is a reliable measure for heat tolerance (Shipler and Blum 1990).

#### D Impact on Quality of the Harvest

High temperature during seed development is associated with a reduction in total oil yield. Under field conditions the negative effect of high temperature gets amplified if there is also a moisture stress. Both temperature and moisture stress together influence the yield of oil in *Brassica* by interfering with seed growth and development. At elevated temperatures, with high night temperatures, a marked reduction in the percentage of linoleic acid occurs, apparently due to desaturase enzymes that are essential for the conversion of oleic to linoleic acid. It is now well recognized that reduced yields and altered oil composition occur in sunflower crop

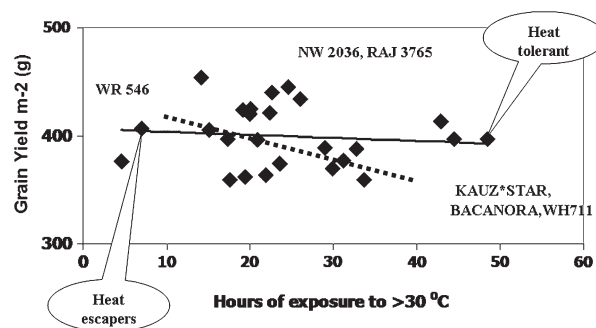

Fig. 2. Effect of high temperature on grain yield in diverse bread wheat genotypes. Twenty-five genotypes were field grown in six locations and were exposed to different temperature regimes (J. Rane, Directorate of Wheat Research, Karnal).

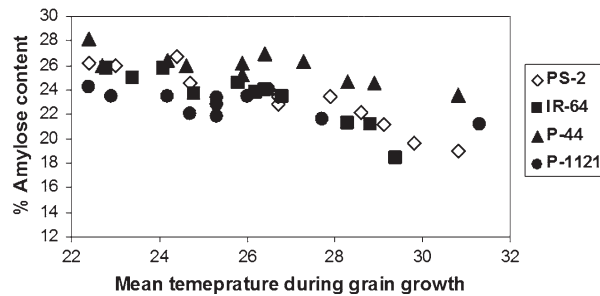

Fig. 3. Effect of mean temperature, during grain-growth period, on amylose content in rice cultivars. Amylase content decreased at the rate of 0.44% per degree rise in temperature in these cultivars (Shantha Nagarajan, IARI, New Delhi).

that matures under high temperature conditions. Whole ranges of metabolic changes that occur due to abnormal temperature cycle adversely affect the biosynthesis of fatty acids in sunflower (Harris et al. 1978). High maximum temperature negatively influences the yield of spring wheat affecting the number of productive tillers per square meter, grain weight, grains per spike and quality of the grain protein. And in cotton, both yield and fiber quality gets affected by non-cardinal temperature regimes. In aromatic and non-aromatic rice cultivars, elevated temperatures, during grain filling period, decrease the amylose content of the grain (Fig. 3).

#### IV Cold and Frost Stress

When soil and/or air temperatures are low during winter season, cold injury occurs in field and horticulture crops. To avoid green and active tissue from getting damaged by blizzard, trees shed their leaves and protect the dormant bud/growing tips by layers of scale. Winter cereals like rye, oats, and to some extent, wheat and barley are tolerant to low temperatures and cold. When temperatures remain sub-zero and the conditions are dry for several days, cereals suffer from cold stress and may die. Being winter hardy and photoperiodic, rye and oats perform better than other winter cereals even under severe cold conditions. Chilling temperature can be defined as any temperature that is cool enough to produce injury but not adequate to freeze the plant. Chilling causes slow down of all chemical reactions in plants and creates cold bite symptoms on plants due to

injury or death of tissue or even the whole plant. In wheat, at the time of ear head emergence, if the temperature is zero to  $-3^{\circ}\text{C}$ , then pollen sterility occurs, resulting in poor grain setting. The anther sterility symptoms, caused by freezing temperature, resemble that of boron deficiency induced pollen sterility. Sub-zero temperatures affect the cell membrane lipids and if chilling is protracted, there is loss of cell contents leading to cell death. Plants have different mechanisms to resist freezing injury. Cauliflower and cabbage have waxy leaf surfaces that avoid physical contact of the leaf epidermis with water droplets as they roll down the waxy leaf surface and this avoids frost damage. Succulent solanaceous crops like potato, tomato and chilies are generally more vulnerable to frost and cold injury. Genotypes with surface wax, or glossy characters, dense epidermal hair, protective scales and other such features reduce frost damage. The tender two leaves and a bud of tea are prone to frost damage during winter months along gradual slopes or brooks or in depression pockets of the tea estate. Estates located at higher elevations are planted with rows of shade trees to avoid frost damage.

Abiotic stress (cold, heat, drought and salinity) in tomato involves the functionality of many genes that lead to a series of biochemical and physiological changes (Ji and Scott 2007). Further, several abiotic stresses affect growth and fruit production in pepper; these include flooding, drought, soil or water salinity, low light intensity and supra- or sub-optimal temperatures. These stresses can directly affect the plant growth and fruit yield or can decrease the fruit quality by inducing fruit malformation (Djian-Caporalino et al. 2007).

## V Water Deficit Stress

When soil moisture is continuously low, water extraction by root and water transport within the plant is reduced and a drought like situation prevails. To overcome drought stress, plants respond by increasing the water extraction efficiency and the water use efficiency of roots, and simultaneously reduce the transpiration rate. Drought is the most important constraint to chickpea yield, accounting for 40–50% yield reduction globally. Four approaches are being pursued:

- High root mass
- Smaller leaf area
- Osmotic adjustment
- Early-maturing short-duration varieties

Most chickpea varieties are susceptible to chilling temperature at the flowering stage and through the efforts of plant breeding, drought tolerant chickpea varieties have been developed.

In general crops grown on residual moisture or under rain-fed situations need the following traits to remain agriculturally productive:

- Capacity of root to extract moisture from lower soil strata
- Reduced evapo-transpiration
- Elasticity of root system so that when soil cracks, roots do not get clipped-off
- Ideal maturity period
- Self-created soil mulch

When the transpiration rate during peak sunshine hours is higher than the water absorption by roots, then transient water stress conditions prevail. This cyclic water/moisture stress situation can occur even under adequate soil moisture conditions. Such cyclic water stress may prevail for few hours during the daytime and subsequently the transpiration rate may normalize by night. This protracted cyclic drought stress can lead to a state of permanent wilting.

### A Effect on Root Pattern

In many succulents such as tomato, potato, celery etc., the shallow spreading root system quickly absorbs the small amount of water supplied by rain. These “rain roots” develop within few hours of shower, mop-up the soil moisture and soon these roots dry out. These crops have an amazing ability to produce water absorbing fresh roots at a very high speed and enable plants to overcome

the water stress. The aerial roots also absorb water from the atmosphere under saturated relative humidity conditions or when there is a fine drizzle. The aerial roots of vanilla and orchids absorb water directly when misty conditions prevail. However, the aerial roots produced by sorghum at the basal internodes are for reducing the anaerobic stress under flooded conditions and serve as “breathing roots”.

Root profile and depth of plants change so to survive under water deficit conditions. Under upland conditions, rice, maize and sorghum have similar root length, density and water extraction patterns down to 60 cm depth (Levitt 1972). Below this level, water extraction by rice is insignificant and this is one of the reasons why rice is more vulnerable to water stress compared to other crops. Generally, rice varieties with high root length density tend to have high leaf water potential and delayed leaf senescence under water deficit conditions. Invariably, rice cultivar with superior root length performs better under water limiting conditions. Under mild water stress situations leaf rolling reduces transpiration loss, increases humidity within the rolled leaf and thereby enables plants to withstand the prevailing harsh water deficit stress conditions. Where repeated spells of transient drought occurs, genotypes with larger root systems tend to perform better.

Seedlings of perennial crops die due to a variety of reasons. Their successful establishment is a requirement for survival and perpetuation of the species. Seedling death is due to poor root development due to which they get knocked off, if they are hit by a severe drought. Survival of the woody species is dependent on whether the root is able to tap the moisture zone in the soil or not. Access to moist soil zone is accomplished by plants with maximum rooting depth. Species that have the capacity to establish roots in these lower moist soil layers survive and contribute to plant population and community dynamics.

### B Effect on Development

In perennial fruit crops, reduced moisture availability at flowering and fruit development stages curtails pollen fertility, berry formation and at subsequent stages causes fruit shedding. Even fruits that eventually mature are of poor quality,

size and appearance. For example, Vines, nuts, and melons produce unfilled fruits and nuts when moisture stress occurs. Early season water stress reduces the number of green leaves, their size, shape and number of fresh leaves per flush. In a row, if annual cyclic water stress occurs, then it badly affects the canopy structure, frame development, number of branches and the strength of twigs and woods.

### *B Effect on Fertility Status*

Male organelle development during meiosis in the microspore mother cells is extremely vulnerable to water deficit conditions. Water deficit adversely affects the development of microspores or pollen grains, causing pollen sterility. Female fertility, in contrast, is relatively unaffected by water stress at this stage. The injury inflicted is apparently not by desiccation of the reproductive tissue, but as a consequence of water deficit in stems and leaves. Stress response probably involves a long-distance signaling molecule, originating in the organs that undergo water loss and affecting fertility in the reproductive tissue which conserves its water status. Therefore, focus has been on the role of abscisic acid under stress situations. Stress-induced arrest of male gametophyte development is preceded by disturbances in carbohydrate metabolism and distribution within anther. An inhibition of the key sugar-cleaving enzyme, acid invertase, decreases sugar delivery to reproductive tissues upon inhibition of photosynthesis under stress conditions. This is the signal that triggers metabolic lesions leading to failure of male gametophyte development (Saini 1997).

### *C Tolerance to Moisture Stress*

There is an inadequacy of experimental evidence to surmise that moisture stress in early stages affects the final yield of annual crops. Often stress at early stages of crop growth stimulates a better root system and makes more soil moisture available when favorable weather returns. Heat or water stress at tillering stage reduces the number of productive tillers in wheat. With the normal weather thereafter, loss is compensated by increased number of grains per spike and better grain weight. When brief periods of moisture stress occurs, the growth loss imposed on the

plant is overcome subsequently by increasing the functional efficiency. Though the scars of stress will be measurable on the crop productivity, the magnitude of loss gets substantially reduced. Plant varieties possessing such alternate mechanisms to minimize the loss inflicted by drought are rated as 'tolerant'.

## **VI Water Logging Stress**

More than one third of the world's irrigated area suffers due to water logging, frequently or otherwise. Water logging limits wheat productivity in at least 10 million hectares around the world. This is due to heavy rainfall, flash floods or from surface irrigation water that accumulates in low field patches with poor infiltration. Temporary water logging occurs when rain water or irrigation is more than what can percolate into the soil within a day or two. Continued flooded conditions lead to lack of oxygen in the soil, restricting respiration of the growing roots and other living organisms. Soil chemical properties also change when anaerobic conditions persist for several days. This is followed by loss of chlorophyll of the lower leaves, arrest of crop growth and proliferation of surface root growth with the retreat of water level. Plant transpiration is affected under anaerobic conditions and extended water logging results in root death due to inadequate oxygen supply. As a consequence, nutrient uptake gets impaired, plant transpiration rate gets altered and due to inadequate root function, the water logged plant rots or withers. Water logging at sowing or germination stage generally kills the seed and the seedling. Under cold conditions the amount of oxygen required for root respiration is reduced. Thus, in colder areas and in northern latitudes, water logging does not create a severe impact on the physiology or the yielding ability of plants at lower latitudes.

### *A Flood Tolerance in Rice*

The rain-fed lowland rice growing conditions of Asia are unique as during crop growth period alternating aerobic and anaerobic soil conditions prevail. The monsoon behavior dictates the duration and magnitude of these spells. During the flooded period the upland rice behaves similar to



irrigated low land rice with reduced growth. Even if the soil is not flooded but is highly wet, then also rice does not show leaf rolling, leaf withering and symptoms of death. But the harvestable yield gets reduced. Continued flooding reduces the availability of phosphorus and results in loss of nitrogen, while the cyclic flooding interferes with the available soil nutrition and thereby affects the general physiology and yield of rice (Singh et al. 1996).

### 1 Role of Root Aerenchyma

Root aerenchyma enables root ventilation under submerged conditions and is an adaptive mechanism to hypoxia. It enables root respiration, gaseous exchange and is an effective adaptation mechanism under continued flooded situations. It is also useful under low phosphorus conditions. There appears to be inter- and intra-species variation for the root aerenchyma in rice and this can be used as a marker to breed flood tolerant varieties.

There are two types of aerenchyma in the root, depending on the position and the type of root. The cortical aerenchyma is the most common, formed either by the disintegration or by the division of cells. The cortical cells are the ones that enable the formation of aerenchyma and cell death of host leads to the formation of aerenchyma through the accumulation of ethylene under low land conditions. Aerenchyma is also formed as a spongy tissue in tap roots, adventitious roots and other rootlets.

### B Effect on Fruit Crops

Water logging of orchard inhibits flower bud initiation, anthesis, fruit set, fruit size and its quality. If flooding happens during the course of fruit development then some fruits burst or crack. The high internal pressure within the fruit, due to osmotic absorption of water through the root, causes fruit cracking. Fruit cracking in grapes and citrus fruits is a major concern and it badly impairs the quality of the fruit (Kozłowski 1997).

## VII Soil-Related Stresses

Salinity induces injury and inhibits seed germination as well as the production of biomass. It alters the physiology and anatomy of the plant. Field flooding may bring in salt from adjacent areas. When water recedes, salt from lower soil profiles comes to the surface due to the capillary movement (Fig. 4). Coastal ecosystems routinely face the problem of sea water inundation due to events like cyclone and *tsunami*. Both chlorides and sodic salts cause damage to the root system of crops. The chloride triggered injury is identifiable by the extensive leaf blade scorching symptoms and the accumulation of sodic salts results in leaf mottling and leaf necrosis. In many of the perennial crops, premature leaf shedding happens, weakening the frame, size and productivity of trees, when the soil pH is not neutral. One way of overcoming this soil-induced problem is identifying proper salinity tolerant root stocks,



Fig. 4. Excess irrigation-induced salinity and the crust of salts on the top soil (FAO Photo Gallery) [See Color Plate 1, Fig. 1].

particularly in citrus and grapes. Soil salinity creates both ionic and osmotic stresses in plants. There is an underlying commonality at downstream gene signaling level between various types of stresses caused by drought, salt and cold that help in the repair of this damage. In some systems, the induced signaling protects plants from further stress damage (Zhu 2001). Recent researches on the molecular mechanisms of stress responses have led to genetic modification of stress tolerance that has wider implications on varietal development (Wang et al. 2003). Using molecular tools, saline tolerant genes have been transferred (Majee et al. 2004) and promising transgenic rice material has been developed.

Acidic soils affect crop growth and yield depending on the level of soil pH. Low soil pH affects plant growth through the toxic effect of Mn and Mg. Plants grown under these conditions produce short, discolored stubby roots, with few laterals. The soil pH influences the availability of micronutrients, except molybdenum which increases with decreasing soil pH. Heavy metal toxicity affects crops when crop husbandry is done at spent mine sites, by usage of sullage water or wherever industrial effluents contaminate the irrigation water. Various heavy metals like mercury, copper, aluminum, and boron and iron contamination affect crop growth (Prasad and Hagemayer 1999), health of the farmer and his farm animals.

#### A Impact on Soil Microbes

Soil living microbial populations favorably contribute to the normal physiology and development of crop by intricately associating with the root system and its function. When soil gets flooded and anaerobic conditions set in, the density of rhizosphere organisms comes down. The root inhabiting beneficial microbes like the vascular arbuscular mycorrhizae (VAM) and arbuscular mycorrhizae (AM), fungi like *Piriformospora indica* and the rhizosphere bacteria suffer under anaerobic soils conditions. These rhizosphere organisms that co-exist in the root make minerals like phosphorus, zinc available, apart from supplying plant growth stimulating substances needed by the plant (Varma et al. 1999).

### VIII Climate Change and Stress in Plants

Climate change refers to any change in climatic parameters over time, as a consequence of natural cyclic changes or due to human activity. Climate change can manifest as a gradual shift in temperature, precipitation and rise in sea-level, affecting long term weather conditions. However, it can also increase the risk of abrupt and non-linear changes in the eco-system, influencing the biodiversity and productivity of the system. Several climatic models project an increase in the level of green house gases (GHGs) leading to an increased frequency, intensity and duration of extreme climatic events. More hot days, heat waves, heavy rainfall, flash floods and droughts are predicted for the future.

Frequent and protracted drought and torrential rainfall, leading to flash flood conditions, are what climate change modelers are predicting for different parts of the globe. The predicted severe drought conditions, during the next few decades, will affect the soil nutrient status. Drought will lead to diminished plant uptake of nutrients such as P and K (Sardans and Penuelas 2007). In soils, where P is already low, this situation will lead to additional stress on plants and ecosystem, since both P and K are necessary for high water-use efficiency and stomatal control.

To cushion crop production against these adversaries, there is an urgent need to quantify the biomass production and harvest index of important crops and develop suitable land use options to sustain agricultural productivity. It is necessary to develop biophysical and socio-economic data, based on agro-ecological regions, using the facilities available in various research farms to assess the overall impact of climate change.

Changes in rainfall patterns will affect soil surface temperatures and moisture availability. This will influence crop establishment, crops stand maturation period and the total agricultural production. Climate change will have an impact on land degradation, leading to water logging, soil salinity and sodicity development in vulnerable areas of the world. The inter-seasonal climatic variability (mainly temperature and rainfall) may influence crop production and food security. It is estimated that a 2°C increase in mean air temperature could decrease rice yield by about 0.75 t/ha

in the high yield areas and by about 0.06 t/ha in the low yield coastal regions (Kalra et al. 2003)

The net balance, after accounting for the gain in production and loss, due to climate change indicates a negative production trend and it is important that future plant physiology research addresses these emerging challenges.

## IX Conclusions

There are several factors that limit agricultural production world-wide, such as the non-availability of timely inputs, soil related problems, out-break of pests and loss due to abiotic stresses. It is projected that globally food prices are likely to increase due to reasons of imbalance in the production and supply chain. The climate change and the global demand for huge quantities of bio-fuel are exerting pressure on the availability of agricultural commodities. It is possible to minimize the loss in agricultural production due to abiotic stresses by a judicious blend of crop physiology knowledge and crop husbandry procedures.

## Acknowledgements

We thank Dr. J. Rane, Directorate of Wheat Research, Karnal for providing Fig. 2.

## References

- Djian-Caporalino C, Lefebvre V, Sage-Daubèze A, Palloix A (2007) Capsicum. In: Singh RJ (ed), Genetic resources, chromosome engineering and crop improvement. Vegetable crops volume 3. Taylor & Francis, London, pp 185–243
- Food and Agriculture Organization (FAO) (2006) The state of food security in the world. FAO, Rome, Italy
- Harris HC, Williams JR, Mason MK (1978) Influence of temperature on oil content and composition of sunflower seed. Aust J Agric Res 29:1203–1212
- Ji Y, Scott JW (2007) Tomato. In: Singh RJ (ed) Genetic resources, chromosome engineering and crop improvement. Vegetable crops volume 3. Taylor & Francis, London, pp 59–113
- Kalra N, Aggarwal PK, Chander S, Pathak H, Choudhary R, Chaudhary A, Mukesh S, Rai HK, Soni UA, Anil S, Jolly M, Singh UK, Owrs A, Hussain MZ (2003) Impacts of climate change on agriculture. In: Shukla PR, Subodh KS, Ravindranath NH, Garg A, Bhattacharya S (eds) Climate change and India: vulnerability assessment and adaptation. University Press, India, pp 191–226
- Kozłowski TT (1997) Responses to woody plants to flooding and salinity. Tree physiology, Monograph No. 1. Heron Publishing, Victoria, Canada, p 29
- Levitt J (1972) Responses of plants to environmental stresses. Academic Press, New York/San Francisco/London
- Lopez MT, Toojinda T, Vanavichit A, Tragoonrun S (2003) Microsatellite markers flanking the tms2 gene facilitated tropical TGMS rice line development. Crop Sci 43:2267–2271
- Majee M, Maitra S, Dastidan GK, Patnaik S, Chatterjee A, Hait NC, Das KP, Majumdar AL (2004) A novel salt tolerant L-myo-Inositol-1-phosphate synthase from *Proteresia Coarctata* (Roxb.) Tateoka, a haplophytic wild rice. J Biol Chem 27:28539–28552
- Prasad MJ, Hagemayer MNV (eds) (1999) Heavy metal stress in plants: from molecules to ecosystems. Springer-Verlag, Berlin/Heidelberg/New York
- Rai AK, Takabe T (eds) (2006) Abiotic stress tolerance in plants. Springer, Berlin
- Saini HS (1997) Effects of water stress on male gametophyte development in plants. Sex P Rep 10:67–73
- Sardans J, Penuelas J (2007) Drought changes phosphorus and potassium accumulation patterns in an evergreen Mediterranean forest. Functional Ecol 21:191–201
- Shipler L, Blum A (1990) Heat tolerance for yield and its components in different wheat cultivars. Euphytica 51:257–263
- Singh VP, Singh RK, Singh BB, Zeigler RS (eds) (1996) Physiology of stress tolerance in rice. Proceedings of the International Conference on Stress Physiology of Rice. Lucknow, India, p 239
- Varma A, Verma S, Sudha SN, Biitehorn B, Franken P (1999) *Piriformospora indica*, a cultivable plant-growth-promoting endophyte. App Environ Microbiol 65:2741–2744
- Wang W, Vinocur B, Altman A (2003) Plant responses to drought, salinity and extreme temperatures: towards genetic engineering for stress tolerance. Planta 218:1–14
- Wardlaw LF, Wrigley CW (1994) Heat tolerance in temperate cereals: an overview. Aust J Plant Physiol 21:695–703
- Zhu JK (2001) Plant salt tolerance. Trends Plant Sci 6: 1360–1385



# Part I

## **Stress Perception and Signal Transduction**

## Sensors and Signal Transducers of Environmental Stress in Cyanobacteria

Yu Kanesaki

*Bio-Resource Genome Analysis Center, Tokyo University of Agriculture,  
Sakuragaoka 1-1-1, Setagaya-ku, Tokyo, 156-8502, Japan*

Dmitry. A. Los

*Institute of Plant Physiology, Russian Academy of Sciences, Botanicheskaya Street 35,  
127276, Moscow, Russia*

Iwane Suzuki

*Graduate School of Life and Environmental Sciences, University of Tsukuba,  
Tennodai, Tsukuba, 305-8572, Japan*

Norio Murata\*

*National Institute for Basic Biology, Myodaiji, Okazaki, 444-8585, Japan*

Summary .....	16
I Introduction.....	16
II Potential Sensors and Signal Transducers in Cyanobacteria .....	17
III Involvement of Two-Component Regulatory Systems in Signal Perception and Transduction during Exposure to Environmental Stress.....	18
A Positive and Negative Regulation of Gene Expression .....	18
B Most Two-Component Systems Regulate Stress-Inducible Gene Expression in a Positive Manner....	19
1 The Hik33-Rre26 System Regulates the Expression of Cold-Inducible Genes .....	19
2. Five Two-Component Systems Contribute to the Perception and Transduction of Salt-Stress and Hyperosmotic-Stress Signals but Regulate Different Sets of Genes .....	22
3 Hik33 is a Major Contributor to Signal Transduction during Oxidative Stress.....	22
4 Several Hiks Are Involved in the Perception and Transduction of Light-Stress Signals .....	23
5 The Hik7-Rre29 System Regulates Gene Expression in Response to Phosphate Limitation .....	23
6 The Hik30-Rre33 System Regulates Gene Expression in Response to Excess Nickel Ions.....	24
C Negative Regulation and Its Involvement in the Transduction of Manganese-Limitation and Heat-Stress Signals.....	24
1 The Hik27-Rre16 System Negatively Regulates Gene Expression in Response to Manganese Limitation .....	24
2 Hik34 Is Involved in Control of the Heat–Stress Response .....	25
3 Hik20 Is Involved in the Regulation of Expression of the <i>kpdABC</i> Operon.....	25
IV Other Potential Sensors and Transducers of Environmental Signals .....	25
A Serine/Threonine Protein Kinases, Tyrosine Protein Kinases and Protein Phosphatases .....	25
B Sigma Factors and Transcription Factors.....	26

\* Author for Correspondence, e-mail: murata@nibb.ac.jp

C Supercoiling of DNA Is Involved in the Perception of Stress Signals and the Regulation of Gene Expression.....	26
V Conclusions and Perspectives.....	27
Acknowledgements.....	27
References.....	28

## Summary

The perception of environmental stress and the subsequent transduction of stress signals are primary events in the acclimation of all organisms to changes in their environment. Many of the molecular sensors and transducers of environmental stress cannot be identified by traditional and conventional methods. Based on genomic information, a systematic approach has been applied to the solution of this problem in cyanobacteria, involving mutagenesis of potential sensors and signal transducers in combination with DNA microarray analyses for the genome-wide expression of genes. Almost all of the histidine kinases (Hiks) and response regulators (Rres) have been successfully inactivated by targeted mutagenesis in the unicellular cyanobacterium *Synechocystis* sp. PCC 6803. Screening of mutant libraries by genome-wide DNA microarray analysis under various stress and non-stress conditions has allowed identification of the Hiks and Rres that perceive and transduce signals of environmental stress. In this chapter, we summarize recent progress in the identification of regulatory two-component systems. In addition, we discuss the potential roles of Spks, DNA supercoiling, sigma factors and transcription factors in the regulation of the responses of cyanobacterial cells to various types of stress.

**Keywords** DNA microarray • environment • histidine kinase • response regulator • sensor • signal perception • signal transduction • stress

## I Introduction

Environmental stresses influence the physiological activities of living organisms. When a change in the environment exceeds a certain threshold level, the activities of some enzymes are inhibited or abolished and those of others are enhanced or induced. In response to moderate stress, many organisms activate sets of genes that are specific

to the individual type of stress. Specific proteins are synthesized and some of these proteins, in turn, participate in the synthesis of certain stress-specific metabolites. The proteins and metabolites that are synthesized *de novo* in response to stress are important for the acclimation of the organism or the cell to the new environment (Fig. 1).

The first steps in acclimation to environmental stress are the perception of such stress and transduction of the resulting signal. Organisms and/or individual cells appear to be equipped with sensors and signal transducers that perceive and transduce signals that result from changes in the environment. Moreover, the sensors and signal transducers appear to be specific to individual types of environmental stress.

The unicellular cyanobacteria have several features that make them particularly suitable for studies of stress responses at the molecular level. The general features of the plasma and thylakoid membranes of cyanobacterial cells are similar to those of the chloroplasts of higher plants in terms of lipid composition and the assembly of membranes. Therefore, cyanobacteria can be expected

---

*Abbreviations:* *cph* – gene for cyanobacterial phytochrome; *crt* – gene for carotenoid metabolism; phytoene desaturase; *etr* – gene for ethylene-receptor; *fab* – gene for fatty-acid biosynthesis; *feo* – gene for ferrous iron transport; FTIR – Fourier-transform infrared spectrometry; *Fus* – gene for fusion; *glo* – gene for glyoxylase (lactoylglutathione lyase); *hlp* – gene for heat-tolerance protein; Hik – histidine kinase; *hli* – gene for high light-inducible protein; *kdp* – gene for high-affinity potassium transporter; *nbl* – gene for phycobilisome degradation protein; *ndh* – gene for NADH dehydrogenase; *pgr* – gene for plant growth regulator; *pho* – gene for low affinity to ortho-phosphate; *rbp* – gene for RNA binding protein; Rre – response regulator; *sig* – RNA polymerase sigma factor; *sph* – gene for *Synechocystis* phosphate sensor/regulator; Spk – serine/threonine protein kinase; Tyr – tyrosine protein kinases

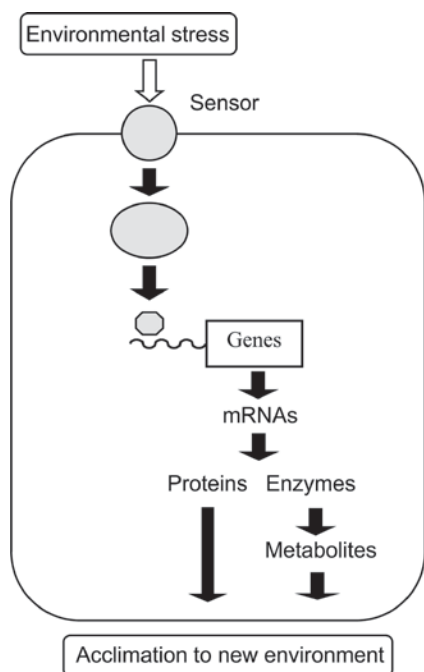

Fig. 1. A general scheme showing the responses of a cyanobacterial cell to environmental stress (Adapted from Murata and Los (2006)).

to serve as powerful model systems for studying the molecular mechanisms of the responses and acclimation to stress (Murata and Wada 1995; Glatz et al. 1999; Los and Murata 2004), also these mechanisms may provide models that are applicable to plants as well.

Some strains of cyanobacteria, such as *Synechocystis* sp. PCC 6803 (hereafter, *Synechocystis*), *Synechococcus elongatus* PCC 7942 (hereafter, *Synechococcus*), and *Synechococcus* sp. PCC 7002, are naturally competent and, thus, foreign DNA is incorporated into cells and is integrated into their genomes by homologous recombination at high frequency (Williams 1988; Haselkorn 1991). In the case of other strains, such as filamentous *Anabaena* sp., other methods of transformation have been developed that are based on the use of broad host-range plasmids and bacterial conjugation (Elhai and Wolk 1988). As a result, cyanobacteria are widely used by researchers for the production of mutants with disrupted genes of interest (for review, see Vermaas 1998).

The entire nucleotide sequence of the genome of *Synechocystis* was determined by Kaneko et al. (1996) as the first sequence of a cyanobacterial

genome to be reported. Subsequently, the entire sequences of all four of the plasmids harbored by *Synechocystis* were reported by this group (Kaneko et al. 2003).

Genome sequences provide vast amounts of basic information, which can be exploited for genome-wide studies of gene expression. In 1999, Takara Bio Co. (Ohtu, Japan) initiated the production of a genome-wide cDNA microarray for the analysis of gene expression in *Synechocystis*. Their DNA microarray covers 3,079 (97%) of the 3,165 genes on the chromosome of *Synechocystis* (99 genes for transposases are excluded from this calculation) but the microarray does not include genes from the four plasmids. The original results of analysis of patterns of gene expression in this cyanobacterium can be found in the KEGG expression database ("List of experimental data available" at <http://www.genome.jp/kegg/expression/>).

In this chapter, we summarize recent progress in studies of sensors and signal transducers of environmental stress in *Synechocystis* that involved both systematic mutagenesis and the use of DNA microarrays.

## II Potential Sensors and Signal Transducers in Cyanobacteria

The existence of two-component sensor-transducer systems has been well established in *Escherichia coli* and *Bacillus subtilis* (Stock et al. 2000; Aguilar et al. 2001). Each two-component system consists of a histidine kinase (Hik) and a cognate response regulator (Rre). In *E. coli* and *B. subtilis*, the genes for the two components of a single system are, in many cases, located close to one another on the chromosome. The Hik perceives a change in the environment via its sensor domain and then a conserved histidine residue within the histidine kinase domain is autophosphorylated, with ATP as the donor of the phosphate group (Stock et al. 2000). The phosphate group is transferred from the Hik to a conserved aspartate residue in the receiver domain of the cognate Rre. Upon phosphorylation, the Rre changes its conformation, and this change allows the binding of the Rre to the promoter regions of genes that are located further downstream in the acclimation pathway (Koretke et al. 2000).

In cyanobacteria, two-component systems, serine/threonine protein kinases, and sigma factors of RNA polymerase are conserved as potential candidates of sensors and transducers of environmental signals. Two-component systems have been found in prokaryotes (including cyanobacteria), fungi, yeasts, plants and lower animals (Koretke et al. 2000) but not in higher animals. In eukaryotes and, in particular, in higher plants and higher animals, serine/threonine protein kinases (hereafter, Ser/Thr kinases or Spks) are the major sensors and/or transducers of environmental signals (Widmann et al. 1999). Sigma factors of RNA polymerases and regulatory factors that modify transcription are also involved in the regulation of gene expression. In addition, environmental stress can affect the superhelicity of DNA, which has been postulated to regulate the gene expression (Dorman 1996).

### III Involvement of Two-Component Regulatory Systems in Signal Perception and Transduction during Exposure to Environmental Stress

The availability of the complete sequence of the *Synechocystis* genome (<http://www.kazusa.or.jp/cyano/Synechocystis/index.html>) has allowed the construction of “knockout” libraries of specific sets of genes by targeted mutagenesis. This technique was used successfully for the identification of many potential sensors and transducers of environmental signals in *Synechocystis* (Suzuki et al. 2000; Paithoonrangsarid et al. 2004; Shoumskaya et al. 2005). In addition, DNA microarray analysis of the genome-wide expression of genes has allowed examination of the effects of mutations in specific genes for Hiks and Rres on the global expression of genes.

The *Synechocystis* chromosome includes 44 putative genes for Hiks (Kaneko et al. 1996; Mizuno et al. 1996) and there are three genes for Hiks on its plasmids (Kaneko et al. 2003). There are 42 putative genes for Rres on the chromosome and three on the plasmids. These 47 Hiks and 45 Rres are candidates for sensors and transducers of environmental signals. However, in *Synechocystis*, the genes for most Hiks and their respective cognate Rres are not located in close proximity to one another on the genome, in contrast to their organization in *E. coli* and

*B. subtilis*. Therefore, to investigate the specific functions of individual Hiks and Rres, it was necessary to mutate genes for Hiks and Rres individually and then to examine the stress-inducible expression of genes in the resultant mutants. In a series of experiments, our group succeeded in completely replacing 44 of the 47 *hik* genes and 42 of the 45 *rre* genes with mutated genes (<http://www.kazusa.or.jp/cyano/synechocystis/mutants/index.html>). Based on this work, we could incompletely segregate a few members of signal transduction pathway which include *hik2*, *hik11*, *hik26*, *rre23*, *rre25* and *rre26* genes.

In the following sections, we describe the principles that govern the regulation of gene expression by two-component systems and we provide examples of the ways in which we identified Hik-Rre two-component systems as sensors and transducers of specific types of environmental stress.

#### A Positive and Negative Regulation of Gene Expression

In principle, two types of regulation of stress-inducible gene expression are mediated by Hik/Rre systems, namely, positive regulation and negative regulation (Fig. 2). In positive regulation (Fig. 2a), a Hik is inactive under non-stress conditions and, as a result, the corresponding Rre is inactive. Genes that are regulated by this type of a two-component system are silent under non-stress conditions. In stressed cells, the Hik is activated by phosphorylation and then the signal is transferred to the cognate Rre, which enhances the expression of genes that are silent under non-stress conditions. Most of the stress-inducible regulation of gene expression in *Synechocystis* is associated with this type of regulation (Murata and Suzuki 2006).

In negative regulation of the stress-inducible expression of genes (Fig. 2b), the Hik is active under non-stress conditions and, as a result, the cognate Rre is also active. Genes that are regulated by this type of two-component system are repressed under non-stress conditions. In stressed cells the Hik and Rre become inactive, resulting in expression of the previously repressed genes (Fig. 2b).

Knockout mutation of either the Hik or the Rre in a two-component system for negative regulation has a marked effect on gene expression under non-stress conditions. The expression of

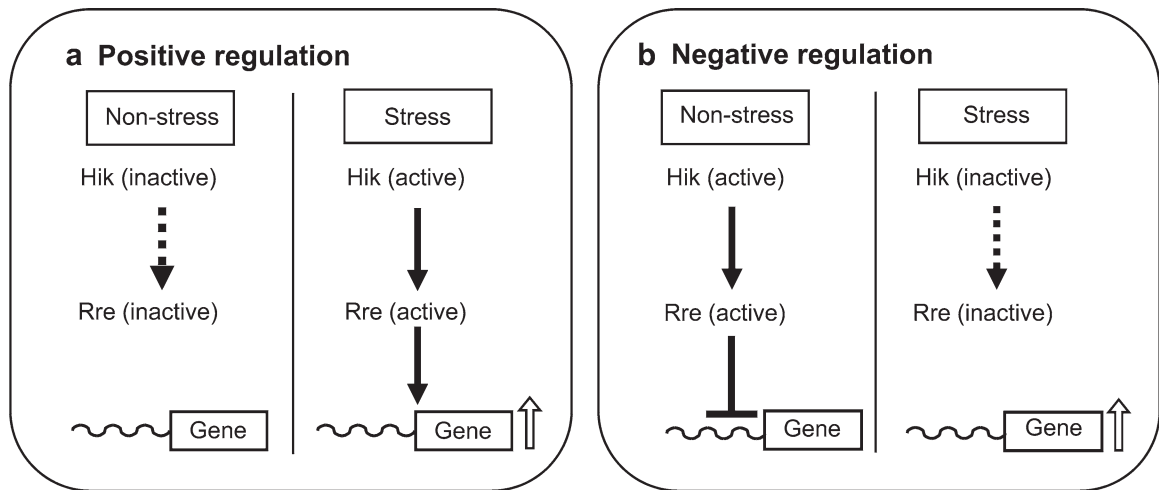

Fig. 2. Schematic representation of (a) positive and (b) negative regulation of stress-inducible expression of genes. Solid arrows indicate signals that activate downstream components and dotted arrows indicate their absence. The inverted 'T' indicates signals that repress the expression of downstream genes. Open arrows correspond to the enhancement of gene expression (Adapted from Murata and Suzuki (2006)).

genes that are controlled by a negatively regulating two-component system is enhanced under non-stress conditions. Therefore, the specific signal-transduction pathway with a specific Hik and its cognate Rre can be identified with relative ease. By contrast, knockout mutation of a Hik and Rre in a two-component system, that operates via positive regulation, does not result in any significant effects on gene expression under non-stress conditions. In this type of two-component system, the identification of the Hik and the Rre in a specific signal-transduction pathway requires the screening of knockout libraries of *hik* and *rre* genes under individual stress conditions.

Screening of our *hik* mutant library by examination of the genome-wide expression of genes with DNA microarrays revealed that mutation of the *hik20*, *hik27* and *hik34* genes induces significant changes in gene expression, in the absence of any change in environmental conditions (i.e., in the absence of stress). Therefore, we postulated that the Hiks encoded by these genes might regulate gene expression in a negative manner. Mutation of the other 41 genes did not significantly alter gene expression, suggesting that Hiks encoded by these 41 genes regulate stress-inducible expression of genes in a positive manner. Although some authors have reported that Hik33 regulates gene expression in a negative manner, their conclusion might have arisen from the use of a mutant that

harbored some additional mutation(s) (Kanesaki et al. 2007). Complementation experiments, with analysis of the genome-wide expression of genes, are necessary to evaluate this discrepancy and confirm this hypothesis.

### B Most Two-Component Systems Regulate Stress-Inducible Gene Expression in a Positive Manner

#### 1 The Hik33-Rre26 System Regulates the Expression of Cold-Inducible Genes

I. Suzuki et al. (2000) identified histidine kinase Hik33 (S110698) as a cold sensor in *Synechocystis*. This Hik has also been described as a component of the drug-resistance machinery (DspA; Bartsevich and Shestakov 1995; Tu et al. 2004) and it is a homolog of NblS of *Synechococcus*, which may be involved in the regulation of genes that are induced when the supply of nitrogen is limited (van Waasbergen et al. 2002). However, the Hik33 does not seem to contribute significantly to the transduction of nutrient-related signals in *Synechocystis* (Zabulon et al. 2007). DNA microarray analysis of *hik33* mutant cells indicated that it regulates the expression of 21 of 35 cold-inducible genes (Fig. 3a), with ratios of transcript levels of cold-stressed cells to those of non-stressed cells higher than 3:1. These 21 genes include



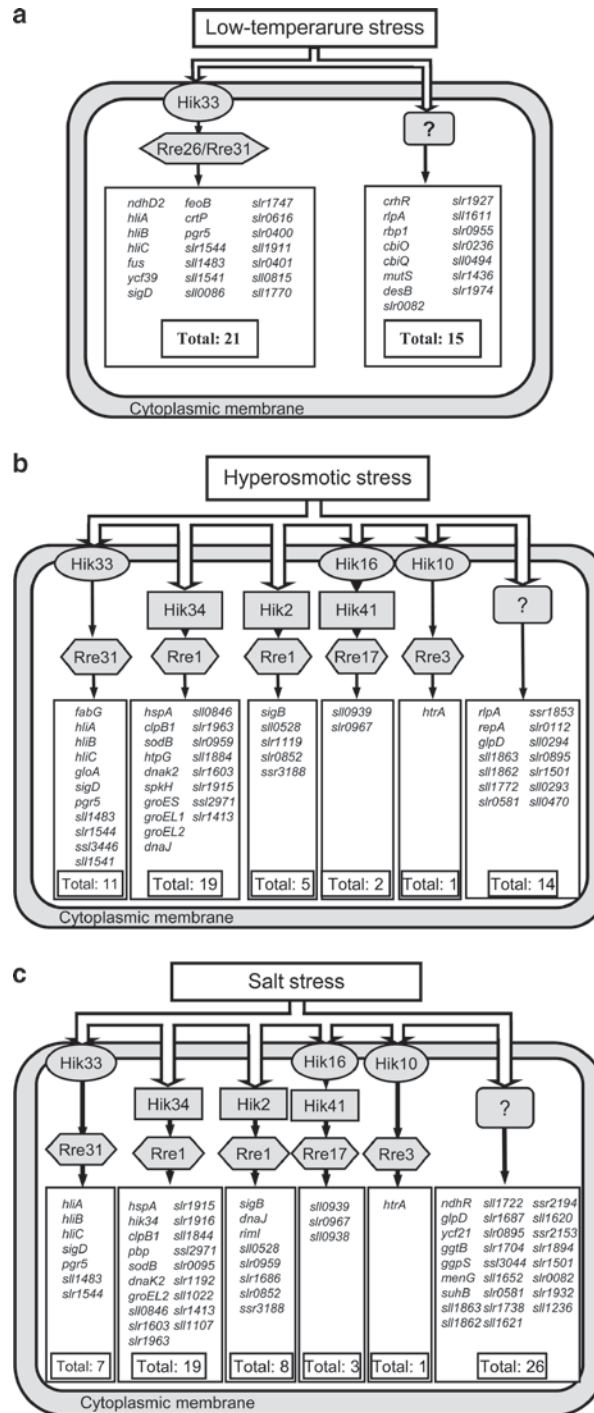

**Fig. 3.** Schematic presentation of two-component systems involved in the transduction of low-temperature stress, salt stress, and hyperosmotic stress, as well as genes controlled by individual two-component systems. Primary signals are represented by open arrows. histidine kinases (Hiks) are indicated as ellipses, response regulators (Rres) are indicated as hexagons and selectively regulated genes are shown in boxes. Uncharacterized mechanisms are represented by question marks. Genes with induction factors (ratios of transcript levels of stressed cells to those of non-stressed cells) higher than 3:1 are included in these schemes. (a) Low-temperature stress (Adapted originally from Suzuki et al. (2001) with inclusion of more recent results). (b) Hyperosmotic stress (Adapted from Paithoonrangsarid et al. (2004); Shoumskaya et al. (2005)). (c) Salt stress (Adapted, with permission, from Shoumskaya et al. (2005)).

*ndhD2*, *hliA*, *hliB*, *hliC*, *fus*, *feoB*, *crtP*, as well as genes for proteins of unknown function. By contrast, 14 of the 35 cold-inducible genes were not regulated by Hik33. Therefore, we deduced that *Synechocystis* might have another pathway for transduction of the low-temperature signal. The genes that are not controlled by Hik33 include *crhR*, which encodes an RNA helicase, and *rbp1*, which encodes a RNA-binding protein.

To identify the Rre that is located downstream of Hik33, we screened an Rre knockout library by RNA slot-blot hybridization using, as probes, some of the cold-inducible genes whose expression is controlled by Hik33. We identified Rre26 as a candidate for the Rre that, with Hik33, constitutes a two-component system for cold-signal transduction (Murata and Los 2006). Moreover, Kappell and van Waasbergen (2007) have recently demonstrated that Rre26 binds to the promoter region of the *hliB* gene, suggesting that this response regulator might be involved in the transduction of the low-temperature signal.

It has been assumed for many years that the increased rigidity of membranes upon a downward shift in temperature should be the primary signal of cold stress. If this assumption is valid, how might Hik33 perceive such rigidification? The Hik33 sensory kinase includes two transmembrane domains, a HAMP linker, a leucine zipper, a PAS domain and a histidine kinase domain (Fig. 4; Los and Murata 1999, 2000, 2002, 2004; Mikami and Murata 2003). The HAMP linker contains two helical regions, in tandem, that are assumed to transduce stress signals across the membrane via intramolecular structural changes (Williams and Stewart 1999; Aravind et al. 2003). Hulko et al. (2006) demonstrated recently that the HAMP linker domain is involved in the dimerization of a membrane-bound Hik and converts an extra- or intra-membrane signal to rotational movement of the Hik molecule. This movement activates the kinase domain (Hulko et al. 2006; Tao et al. 2002). In Hik33, the two transmembrane domains might sense changes in membrane rigidity since they are the segments of Hik33 that are associated with the lipid phase of the membrane (Los and Murata 2004).

Tasaka et al. (1996) produced a series of *Synechocystis* mutants, in which the extent of unsaturation of fatty acids was modified in a

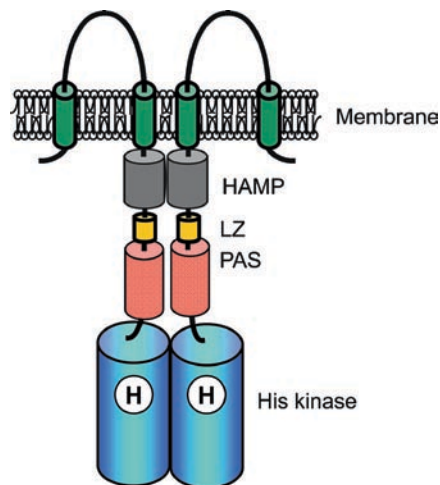

Fig. 4. Schematic presentation of the dimeric structure of Hik33 and its interactions with the cell membrane. A decrease in temperature stiffens the membrane leading to a compression of the lipid bilayer, which forces membrane-spanning domains to come closer to each other, changes the linker conformation and finally causes autophosphorylation of histidine kinase domains. Hepcidin antimicrobial peptide (HAMP), HAMP-linker domains; LZ, leucine zipper domains; PER-ARNT-SIM (PAS), PAS domains that contain the amino acid motifs Per, Arnt, Sim and phytochrome (Taylor and Zhulin 1999); histidine kinase (Hik) kinase, histidine kinase domain; and H in circles, histidine residues that can be phosphorylated in response to cold stress (Adapted from Murata and Los (2006)) [See Color Plate 1, Fig. 2].

step-wise manner. Changes in the fluidity of membrane lipids, due to each mutation, were verified by Fourier Transform Infrared spectroscopy (FTIR) (Szalontai et al. 2000). Examination of the cold-induced expression of genes in these mutant cells with DNA microarrays revealed that rigidification (increased saturation) of membrane lipids apparently enhanced the responses of gene expression to low temperature.

These various findings indicated that Hik33 regulates the expression of many genes. They also suggested that the activity of Hik33 in the sensing of low temperature depends on membrane rigidity and that there are at least two other cold sensors, one depending on membrane rigidity, while the other functions independently of the saturation of membrane lipids (Inaba et al. 2003; for more detailed reviews, see Los and Murata 2004; Murata and Los 2006).

## 2 Five Two-Component Systems Contribute to the Perception and Transduction of Salt-Stress and Hyperosmotic-Stress Signals but Regulate Different Sets of Genes

In the literature, hyperosmotic stress and salt stress are frequently regarded as identical forms of stress. However, they are distinctly different. Hyperosmotic stress causes the efflux of water from the cytoplasm, resulting in a decrease in cytoplasmic volume and increased concentrations of cytoplasmic solutes and other components. By contrast, salt stress decreases the cytoplasmic volume only transiently and to a small extent (Kanesaki et al. 2002), while rapidly increasing cytoplasmic concentrations of Na<sup>+</sup> and Cl<sup>-</sup> ions (Allakhverdiev et al. 2002) via an influx of NaCl through Na<sup>+</sup>/K<sup>+</sup> and Cl<sup>-</sup> channels.

Comprehensive screening with DNA microarrays, of the *hik* mutant library upon exposure of the cells to salt (NaCl) stress revealed that the inducibility of gene expression by elevated levels of NaCl was significantly affected in  $\Delta hik16$  (*slr1805*),  $\Delta hik33$  (*sll0698*),  $\Delta hik34$  (*slr1285*), and  $\Delta hik41$  (*sll1229*) mutant cells (Marin et al. 2003). In each of these mutants, the expression of several genes was no longer induced by salt or the extent of inducibility by salt was markedly reduced.

By screening an Rre knockout library by RNA slot-blot hybridization and with the genome-wide DNA microarray, we identified four Hik-Rre systems, namely, Hik33-Rre31, Hik10-Rre3, Hik16-Hik41-Rre17 and Hik34-Rre1 that appeared to be involved in the perception of salt stress and transduction of the signal (Shoumskaya et al. 2005). Fig. 3c shows a hypothetical scheme for the salt signal-transducing systems that involve these Hiks and Rres. The scheme includes those salt-inducible genes that are controlled by individual Hik-Rre two-component systems.

The perception and transduction of hyperosmotic-stress signals involve the same four Hik-Rre systems and another potential two-component system, namely, Hik2-Rre1 (Paithoonrangsarid et al. 2004). Fig. 3b shows the signal-transduction pathways that operate when cells are exposed to hyperosmotic stress, as well as the hyperosmotic stress-inducible genes whose expression is controlled by the individual Hik-Rre systems.

As shown schematically in Fig. 3b and 3c, in *Synechocystis*, hyperosmotic stress and salt stress, respectively, appear to be perceived by identical sets of Hik-Rre systems, which regulate rather similar sets of genes, albeit to different extents. However, it is also clear that identical Hik-Rre systems may also control the expression of different sets of genes under hyperosmotic stress and salt stress (Figs. 3b, c). Typical examples are the Hik33-Rre31 and Hik34-Rre1 pairs mentioned above. The Hik33-Rre31 two-component system regulates the expression of *fabG* and *gloA* as hyperosmotic stress-specific genes and that of *pgr5*, *nblA1* and *nblA2* as oxidative stress-specific genes. The Hik34-Rre1 system regulates the expression of *sll1107* as a salt stress-specific gene (Fig. 3c) and that of *htpG* as a hyperosmotic stress-specific gene (Fig. 3b). The current concept of two-component systems does not explain how the Hik33-Rre31 system controls the differential expression of the two different sets of genes under different types of stress. It seems reasonable to postulate the presence of some unknown factor(s) that provide each two-component system with the strict specificity that is related to the specific nature of the stress.

## 3 Hik33 is a Major Contributor to Signal Transduction during Oxidative Stress

Screening of the library of Hik mutant cells by monitoring changes in the genome-wide expression of genes upon exposure to oxidative stress (0.25 mM H<sub>2</sub>O<sub>2</sub>) for 20 min revealed four histidine kinases, Hik34, Hik16, Hik41, and Hik33, regulating the oxidative stress-inducible expression of genes. These Hiks regulate the expression of 26 of the 77 H<sub>2</sub>O<sub>2</sub>-inducible genes with ratios of transcript levels of H<sub>2</sub>O<sub>2</sub>-stressed cells to that of non-stressed cells greater than 4:1 (Kanesaki et al. 2007). Hik34, which was identified as a sensor/transducer of signals due to salt (Shoumskaya et al. 2005) and hyperosmotic (Paithoonrangsarid et al. 2004) stress, also regulates the expression of the H<sub>2</sub>O<sub>2</sub>-inducible *htpG* gene. Hik16 and Hik41 together regulate the expression of *sll0967* and *sll0939*. Hik33 is the main contributor to the regulation of H<sub>2</sub>O<sub>2</sub>-inducible gene expression and regulates the induction of expression of 22 of the 26 H<sub>2</sub>O<sub>2</sub>-inducible genes that are under the control of histidine kinases. Hik33 regulates

the expression of the *ndhD2* gene, *hli* genes, *pgr5* gene (for ferredoxin-plastoquinone reductase), *nblA1* and *nblA2* genes (for proteins involved in the degradation of phycobilisomes), and of several other genes (Kanesaki et al. 2007). The cognate Rre of each of these Hiks in the transduction of oxidative signals has not yet been identified.

#### 4 Several Hiks Are Involved in the Perception and Transduction of Light-Stress Signals

The potential sensors of light in *Synechocystis* are Histidine Kinases with phytochrome-like features (Kehoe and Grossman 1994, 1996). The *Synechocystis* genome contains seven *hik* genes, namely, *hik35* (*slr0473*), *hik3* (*sll1124*), *hik32* (*sll1473/sll1475*), *hik1* (*slr1393*), *hik44* (*slr1212*), *hik24* (*slr1969*), and *hik18* (*sll0041*), that are homologous by various degrees to plant genes for phytochromes.

When the *hik35* (*cph1*) gene was expressed in *E. coli* cells that synthesized phycocyanobilin, the *E. coli* cells produced an adduct with a red/far-red photoreversible signature that is typical of phytochrome (Hughes et al. 1997). The *rre27* (*rcp1* or *slr0474*) gene is located adjacent to the *hik35* gene (Yeh et al. 1997). Insertional inactivation of *hik35* in *Synechocystis* impaired the growth of mutant cells under continuous far-red light (Fiedler et al. 2004).

An attempt to identify the molecular targets of Hik35 (Cph1) activity was made using the DNA microarray (Hübschmann et al. 2005). In wild-type and two lines of phytochrome-mutant cells, 25% of all 3,165 putative genes responded to light. Red light predominantly enhanced the expression of genes whose products are involved in transcription, translation, and photosynthesis, whereas far-red light raised the levels of transcripts of genes whose expression is induced by various kinds of stress. The mutation of *hik35* (*cph1*) altered the light-dependent expression of approximately 20 genes. Hence, light receptor(s) different from this two-component system might trigger global red/far-red-induced alterations in the profile of gene expression.

It seems unlikely that all Hiks mentioned above are typical phytochromes in terms of red/far-red reversibility of their activities. Indeed, Hik3 seems to be involved in blue light-dependent

growth (Wilde et al. 1997), and Hik44 (Etr1) binds ethylene (Sineshchekov et al. 1998). The potential involvement in the perception of light-stress signals of Hik32 [which is, incidentally, intact in a strain from the Pasteur Culture Collection but is disrupted by an insertion in a strain from Dupont (Okamoto et al. 1999)], Hik1, and Hik24 merits further investigation. The involvement of the Hik33-Rre26 system in light-regulated gene expression has also been suggested (Hsiao et al. 2004; Tu et al. 2004; Kappell and van Waasbergen 2007).

In *Synechococcus elongatus* PCC 7942, two histidine kinases, namely, SasA (an ortholog of Hik8) and CikA (an ortholog of Hik24), have been identified as signal transducers in the establishment of circadian rhythm (Iwasaki et al. 2000; Schmitz et al. 2000). SasA transfers a phosphate group to its cognate response regulator, RpaA (an ortholog of Rre31), in the presence of KaiC, and acts as a major mediator of circadian timing that regulates the oscillation of gene expression (Takai et al. 2006).

In the filamentous cyanobacterium *Calothrix* sp. PCC7601, Jorissen et al. (2002) identified CphA-RcpA and CphB-RcpB as two-component, light-sensing, phytochrome-like systems. Both of these regulatory systems are homologous to Hik35-Rre27 in *Synechocystis*. In *Anabaena*, Vogeley et al. (2004) and Sineshchekov et al. (2005) identified a cyanobacterial rhodopsin whose biochemical and biophysical characteristics suggest its involvement in the regulation of chromatic adaptation.

#### 5 The Hik7-Rre29 System Regulates Gene Expression in Response to Phosphate Limitation

Hirani et al. (2001) discovered that the *hik7* (*sll0337* or *sphS*) and *rre29* (*slr0081* or *sphR*) genes in *Synechocystis* encode proteins that are homologous, respectively, to PhoR and PhoB of *E. coli*, PhoR and PhoP of *B. subtilis*, and to SphS and SphR of *Synechococcus* sp. PCC 7942. They reported that the Hik7-Rre29 two-component system induces the expression of the *phoA* gene for Alkaline Phosphatase in response to phosphate limitation.

DNA microarray analysis of the genome-wide expression of genes in *Synechocystis* revealed that the expression of 12 genes was strongly induced



while that of one gene was strongly repressed when the supply of phosphate was limited (Suzuki et al. 2004). The expression of all phosphate limitation-inducible genes was completely eliminated upon inactivation of either Hik7 or Rre29. The response regulator Rre29 binds to the upstream flanking regions of three genes at repetitive PyTTAAPyPy(T/A)-like sequences (where Py represents a pyrimidine). Our observations suggested that the Hik7-Rre29 two-component system might be the only system for the perception and transduction of the phosphate-limitation signal in *Synechocystis* (Suzuki et al. 2004).

However, a recent investigation demonstrated that another component, SphU (slr0741), contributes to transduction of the phosphate-limitation signal in *Synechocystis* (Juntarajumnong et al. 2007). This component negatively regulates the expression of the *phoA* gene for alkaline phosphatase. The threonine residue at position 167, adjacent to the histidine residue of SphS (Hik7) that can be phosphorylated in response to phosphate limitation, is important in the negative regulation mediated by SphU.

### 6 The Hik30-Rre33 System Regulates Gene Expression in Response to Excess Nickel Ions

Lopez-Maury et al. (2002) identified the Hik30-Rre33 (or NrsS-NrsR) two-component system that regulates transcription of the *nrsBACD* operon, which is involved in the resistance to excess of Ni<sup>2+</sup> ions. The *hik30-rre33* operon is located near the *nrsBACD* operon with subunits of the ABC-type Ni<sup>2+</sup> ion transporter. Knockout mutation of either the *hik30* or the *rre33* gene completely abolishes the Ni<sup>2+</sup>-induced transcription of the *nrsBACD* operon. In addition, mutation of Rre33 caused the accumulation of transcripts of genes for components of PSII, such as *psbA* and *psbD*, and suppressed that of genes in phycobilisomal operons, such as *apcAB* and *cpcBA*, under conditions of normal light intensity (Li and Sherman 2000). These observations suggested that the mutant cells might not be able to sense the accumulation of excess Ni<sup>2+</sup> ions, which might have toxic effects on the cells. As a result, the mutant cells fail to survive when the concentration of Ni<sup>2+</sup> ions in the growth medium is elevated. It is probable that Hik30 binds a Ni<sup>2+</sup> ion and is then autophosphorylated. The phosphate group is then

transferred to Rre33, which binds to the intergenic regions of *nrsRS* and *nrsBACD*, which are located close to each other on the chromosome, stimulating transcription of the latter operon. This example represents, therefore, a positive type of regulatory system. The use of microarray analysis to investigate the genome-wide pattern of gene expression under appropriate conditions should enhance our understanding of the relationship between Ni<sup>2+</sup> homeostasis and cellular metabolism.

### C Negative Regulation and Its Involvement in the Transduction of Manganese-Limitation and Heat-Stress Signals

#### 1 The Hik27-Rre16 System Negatively Regulates Gene Expression in Response to Manganese Limitation

Screening of our Hik and Rre mutant libraries, under non-stress conditions revealed that Hik27 and Rre16 constitute a two-component system for the perception of manganese limitation and transduction of the resultant signal (Yamaguchi et al. 2002). Using DNA microarrays, we compared gene expression in  $\Delta$ *hik27* mutant cells with that in wild-type cells during growth under non-stress conditions, namely, in BG-11 medium that contained 9  $\mu$ M Mn<sup>2+</sup> ions. Marked changes, with ratios of transcript levels greater than 10:1, due to mutation of the *hik27* gene (*slr0640*) or the *rre16* gene (*slr1837*), were recognized only in the expression of three genes, namely, *mntC*, *mntA*, and *mntB*, which constitute the *mntCAB* operon that encodes subunits of the ABC-type Mn<sup>2+</sup> transporter (Bartsevich and Pakrasi 1995, 1996). These results suggest that the Hik27-Rre16 two-component system might be active under non-stress conditions and might repress the expression of the *mntCAB* operon. Moreover, disappearance of this signal, due to inactivation of either Hik27 or Rre16, might allow the *mntCAB* operon to be expressed. However, mutation of *hik27* or *rre16* abolished the Mn<sup>2+</sup> limitation-induced expression of the *mntCAB* operon (Yamaguchi et al. 2002; Ogawa et al. 2002), working independently and using traditional methods, identified the same two-component system as the sensor and signal transducer of Mn<sup>2+</sup> limitation.

### 2 *Hik34 Is Involved in Control of the Heat-Stress Response*

Screening of the Hik mutant library under non-stress conditions using DNA microarrays, allowed the identification of Hik34 as an important contributor to the regulation of expression of heat-shock genes and acquisition of thermotolerance in *Synechocystis* (Suzuki et al. 2005). Mutation of the *hik34* gene enhanced the levels of transcripts of a number of heat-shock genes, which included *htpG* and *groESL1*. Furthermore, overexpression of the *hik34* gene repressed the expression of these heat-shock genes. In addition, Hik34-mutant cells survived incubation at 48°C for 3 h, while wild-type cells, and cells with mutations in other Hiks, failed to do so. However, mutation of the *hik34* gene had only an insignificant effect on the global expression of genes during incubation of the mutant cells at 44°C for 20 min. Among 59 heat stress-inducible genes with ratios of transcript levels greater than 3:1, mutation of the *hik34* gene markedly decreased the heat inducibility of only two genes, namely, *htpG* and *slr1963*. Recombinant Hik34 expressed in *E. coli* was autophosphorylated *in vitro* at physiological temperatures but not at elevated temperatures, such as 44°C (Suzuki et al. 2005). Thus, it seems likely that Hik34 is involved in the negative regulation of the expression of certain heat-shock genes that might be related to thermotolerance in *Synechocystis*.

### 3 *Hik20 Is Involved in the Regulation of Expression of the kdpABC Operon*

Hik20 (Sll1590) of *Synechocystis* is homologous to KdpD of *E. coli*, which has been identified as a sensor of K<sup>+</sup> limitation (Jung et al. 2000). Rre19 (Sll1592) is homologous to KdpE, which thus represents the cognate response regulator. Therefore, it seems likely that the Hik20-Rre19 system is involved in signal transduction when the supply of K<sup>+</sup> ions is limited.

Screening of the Hik mutant library under non-stress conditions using DNA microarrays allowed the identification of Hik20 as an important contributor to the regulation of expression of the *kdpABC* operon in *Synechocystis*. Mutation of *hik20* enhanced the levels of transcripts of the *kdpA* and *kdpB* genes, which are assumed

to encode components of the K<sup>+</sup> ion transport system, and of several other genes, such as the *pilA1-pilA2-sll1696* operon (see “List of experimental data available” at <http://www.genome.jp/kegg/expression/>). However, mutation of Rre19 did not enhance the level of *kdpA* and *kdpB* transcripts, suggesting that the Hik20-Rre19 system is not entirely homologous to the KdpD-KdpE system (Walderhaug et al. 1992).

## IV Other Potential Sensors and Transducers of Environmental Signals

### A Serine/Threonine Protein Kinases, Tyrosine Protein Kinases and Protein Phosphatases

While eubacteria, including cyanobacteria, use two-component systems for many types of signal transduction, eukaryotes exploit Spk, Tyr kinases and protein phosphatases for similar purposes. The presence of genes for Ser/Thr kinases and phosphatases in cyanobacteria was revealed only when the complete sequence of the *Synechocystis* genome became available (Zhang et al. 1998). The putative proteins were identified by comparison of deduced amino acid sequences encoded by open-reading frames with known amino acid sequences of eukaryotic protein kinases.

Among 12 putative genes for Ser/Thr kinases in *Synechocystis*, seven encode proteins that belong to the PKN2 subfamily of Ser/Thr kinases and five encode proteins that belong to the ABC1 subfamily of Ser/Thr kinases (Leonard et al. 1998; Shi et al. 1998). The genes for kinases of the PKN2 type are designated *spkA*, *spkB*, *spkC*, *spkD*, *spkE*, *spkF* and *spkG* and those for kinases of the ABC1 type are designated *spkH*, *spkI*, *spkJ*, *spkK* and *spkL* (cyanoBase; <http://www.kazusa.or.jp/cyano/>). The functions of the products of only three of these genes have been characterized to date (Zhang et al. 2005). SpkA and SpkB appear to be involved in the control of cell motility (Kamei et al. 2001, 2003), while SpkE is probably involved in the regulation of nitrogen metabolism (Galkin et al. 2003).

A recent study with DNA microarrays demonstrated the relationships among the activity of SpkA, the genome-wide expression of certain



genes, the formation of thick pili, and cell motility (Panichkin et al. 2006). It is likely that, under non-stress conditions, SpkA activates the expression of the putative *pilA9-pilA10-pilA11-slr2018* operon and inactivates the expression of the *pilA5-pilA6* and *pilA1-pilA2* operons. Electron microscopy revealed that SpkA activity is essential for the formation of thick pili. It seems likely that SpkA is a regulator of the expression of these putative operons, whose products are regulators of the formation of thick pili, which are, in turn, essential for cell motility. The molecular mechanism responsible for the contribution of SpkB to cell motility remains to be clarified.

Systematic analysis of the regulation of gene expression using DNA microarrays has not been applied to the functional characterization of the other Ser/Thr kinases, Tyr kinases and protein phosphatases. Much work remains to be done.

### B Sigma Factors and Transcription Factors

The *Synechocystis* genome contains nine open-reading frames that encode putative sigma factors (Kaneko et al. 1996). Sequence homology suggests that the *sigA* gene encodes the primary sigma factor; the *sigB*, *sigC*, *sigD*, and *sigE* genes encode group 2 sigma factors; and the *sigF*, *sigG*, *sigH*, and *sigI* genes encode group 3 sigma factors. Although attempts to characterize the functional role of each sigma factor have recently been made, systematic analysis using DNA microarrays has not been performed except for SigE, a regulator of sugar catabolic pathways (Osanai et al. 2005).

A search for and classification of DNA-binding transcription factors in *Synechocystis*, was conducted using the sequence of the genome and a set of bioinformatic tools. Fifty-seven genes for transcription factors, that account for 1.7% of all genes, in the *Synechocystis* genome were found. The transcription factors include the DNA-binding domains of seven families of factors. In total, 44 transcription factors have a winged helix or the carboxy-terminal effector domain of bipartite response regulators (V.V. Zinchenko, personal communication).

The functions of several transcription factors have been characterized. The role of a LysR-type regulator of transcription, NdhR (Sll1594), was

studied systematically with DNA microarrays (Wang et al. 2004a). NdhR negatively regulates the expression of its own gene, as well as that of the *ndhF3* and *ndhD3* genes for NDH-1 (NADH dehydrogenase-1) complex. NdhR also regulates the expression of the *nhaS1* (*slr1727*) gene for one of the Na<sup>+</sup>/H<sup>+</sup> antiporters.

HrcA (Sll1670) encodes an ortholog of a protein that negatively regulates the expression of the heat-shock *grpE-dnaK-dnaJ* and *groESL* operons for chaperonins in *B. subtilis* (Hecker et al. 1996). In *Synechocystis*, HrcA appears to only regulate the expression of the *groESL* operon and the *groEL2* gene in response to heat stress (Nakamoto et al. 2003), suggesting that expression of other heat-shock genes might be regulated by different mechanisms. SufR (sll0088) functions as a repressor of the *sufBCDS* operon, which is involved in the biogenesis of the iron-sulfur cluster in Photosystem-I (Wang et al. 2004b). ArsR (sll1957) represses the expression of the *arsBHC* operon, which consists of three genes: the *arsB* gene that encodes a putative arsenite and antimonite carrier; the *arsH* gene that encodes a protein of unknown function; and the *arsC* gene that encodes a putative arsenate reductase that confers arsenic resistance (López-Maury et al. 2003). However, no systematic analysis using DNA microarrays has been performed to examine the roles of these transcription factors.

### C Supercoiling of DNA Is Involved in the Perception of Stress Signals and the Regulation of Gene Expression

Alterations in the supercoiling of genomic DNA play important roles in the regulation of gene expression in response to environmental stress both in Gram-negative and Gram-positive bacteria (Higgins et al. 1988; Wang and Lynch 1993; Dorman 1996; Weinstein-Fischer et al. 2000). It has been proposed that temperature-dependent alterations in DNA supercoiling might be one of the sensory mechanisms that regulate the expression of genes involved in the acclimation to low temperature (Grau et al. 1994; Los 2004). Salt stress and hyperosmotic stress also affect the negative supercoiling of DNA and regulate gene transcription (Graeme-Cook et al. 1989; Conter et al. 1997; Cheung et al. 2003).

Studies of changes in the supercoiling of DNA were initially limited to plasmid DNAs in *E. coli*, *B. subtilis* and *Salmonella typhimurium*. Therefore, changes in gene expression due to changes in the supercoiling of chromosomal DNA, have mainly been assumed on the basis of changes in the linking numbers of plasmids (Aoyama and Takanami 1988; Franco and Drlica 1989; Adamcik et al. 2002). An inhibitor of DNA gyrase, novobiocin (Gilmour and Gellert 1961; Gellert et al. 1976), has been used to examine the effects of changes in the negative supercoiling of DNA on the genome-wide expression of genes in *Synechocystis* in response to cold stress. Novobiocin interacts with the ATP-binding site of the B-subunit of DNA gyrase. Cold stress caused an increase in the negative supercoiling of the promoter region of the *desB* gene for a fatty acid desaturase and directly controlled its expression at low temperatures (Los 2004), suggesting that the supercoiling of DNA might contribute to stress-induced gene expression in cyanobacteria.

## V Conclusions and Perspectives

Here, we have demonstrated how genome-based systematic analysis provides a powerful technique with which we can identify, with relative ease, the Hiks and Rres that are involved in the perception and transduction of stress signals. Without this approach, it would have been very difficult to reveal that Hik33 regulates the expression of most cold-inducible genes in *Synechocystis* and, furthermore, that five two-component systems are involved in the perception of salt stress and hyperosmotic stress, as well as the transduction of the respective signals.

We will now have to determine how a single two-component system can perceive and transduce more than one kind of environmental signal (Los and Murata 2002, 2004; Mikami et al. 2002). For example, Hik33-Rre31 is involved in the sensing of salt stress and hyperosmotic stress, but it regulates different sets of genes in response to each respective stress. Similarly, Hik34-Rre1 is involved in the sensing of salt stress and of hyperosmotic stress but also regulates different sets of genes in response to each type of stress. Moreover, Hik33-Rre26 contributes to the regulation of gene expression upon exposure of cells to cold stress and light stress, whereas Hik33-Rre31 does

so upon exposure of cells to hyperosmotic and salt stress. It is interesting to note, in this context, that three genes homologous to *hik33*, *rre26*, and *rre31*, respectively, are encoded by the plastid genome of some red and golden-brown algae (Duplessis et al. 2007).

The observations, summarized above, cannot be explained by the current model of two-component systems, in which a Hik perceives a specific stress and regulates the expression of a particular set of genes via the phosphorylation-dependent activation (or inactivation) of its cognate Rre. A full explanation will require elucidation of more details regarding the mechanisms of signal perception and transduction. It is probable that as-yet-unidentified components are important in determining the specificity of responses to individual types of stress. It is also possible that sensors of environmental signals are highly organized protein complexes, in which Hiks, Rres and various unidentified components are somehow associated and that changes in the composition of the complex could provide specificity. To identify these components, we shall have to develop and introduce new techniques, which, most probably, will exploit the information encoded in the genomes of other cyanobacteria and other organisms.

The functional characterization of Ser/Thr kinases, sigma factors of RNA polymerases and transcription factors will also be important, and studies of the contribution of DNA superhelicity to gene expression may yield novel insights into the perception of environmental-stress signals and the regulation of gene expression. A combination of physiological, biochemical, and genetic approaches should lead to a deeper understanding of the mechanisms of stress responses in lower and higher organisms.

## Acknowledgements

This work has been supported by the Cooperative Research Program of the National Institute for Basic Biology, Japan, by a Sasagawa Scientific Research Grant from the Japan Science Society to Y.K., a grant from the Russian Foundation for Basic Research (no. 09-04-01074) and a grant from the "Molecular and Cell Biology Program" of the Russian Academy of Sciences to D.A.L.

## References

- Adamcik J, Viglasky V, Valle F, Antalík M, Podhradský D, Dietler G (2002) Effect of bacteria growth temperature on the distribution of supercoiled DNA and its thermal stability. *Electrophoresis* 23:3300–3309
- Aguilar PS, Hernandez-Arriaga AM, Cybulski LE, Erazo AC, de Mendoza D (2001) Molecular basis of thermosensing: a two-component signal transduction thermometer in *Bacillus subtilis*. *EMBO J* 20:1681–1691
- Allakhverdiev SI, Nishiyama Y, Miyairi S, Yamamoto H, Inagaki N, Kanesaki Y, Murata N (2002) Salt stress inhibits the repair of photodamaged Photosystem II by suppressing the transcription and translation of *psbA* genes in *Synechocystis*. *Plant Physiol* 130:1443–1453
- Aoyama T, Takanami M (1988) Supercoiling response of *E. coli* promoters with different spacer lengths. *Biochim Biophys Acta* 949:311–317
- Aravind L, Anantharaman V, Iyer LM (2003) Evolutionary connections between bacterial and eukaryotic signaling systems: a genomic perspective. *Curr Opin Microbiol* 6:490–497
- Bartsevich VV, Pakrasi HB (1995) Molecular identification of an ABC transporter complex for manganese: analysis of a cyanobacterial mutant strain impaired in the photosynthetic oxygen evolution process. *EMBO J* 14:1845–1853
- Bartsevich VV, Pakrasi HB (1996) Manganese transport in the cyanobacterium *Synechocystis* sp. PCC 6803. *J Biol Chem* 271:26057–26061
- Bartsevich VV, Shestakov SV (1995) The *dspA* gene product of the cyanobacterium *Synechocystis* sp. strain PCC 6803 influences sensitivity to chemically different growth inhibitors and has amino acid similarity to histidine protein kinases. *Microbiology* 141:2915–2920
- Cheung KJ, Badarinarayana V, Selinger DW, Janse D, Church GM (2003) A microarray-based antibiotic screen identifies a regulatory role for supercoiling in the osmotic stress response of *Escherichia coli*. *Genome Res* 13:206–215
- Conter A, Menchon C, Gutierrez C (1997) Role of DNA supercoiling and *rpoS* sigma factor in the osmotic and growth phase-dependent induction of the gene *osmE* of *Escherichia coli* K12. *J Mol Biol* 273:75–83
- Dorman CJ (1996) Flexible response: DNA supercoiling, transcription and bacterial adaptation to environmental stress. *Trends Microbiol* 4:214–216
- Duplessis MR, Karol KG, Adman ET, Choi LY, Jacobs MA, Cattolico RA (2007) Chloroplast His-to-Asp signal transduction: a potential mechanism for plastid gene regulation in *Heterosigma akashiwo* (Raphidophyceae). *BMC Evol Biol* 7:70. <http://www.biomedcentral.com/1471-2148/7/70> (May 3, 2007)
- Elhai J, Wolk CP (1988) Conjugal transfer of DNA into cyanobacteria. *Methods Enzymol* 167:747–765
- Fiedler B, Broc D, Schubert H, Rediger A, Boerner T, Wilde A (2004) Involvement of cyanobacterial phytochromes in growth under different light qualities and quantities. *Photochem Photobiol* 79:551–555
- Franco RJ, Drlica K (1989) Gyrase inhibitors can increase *gyrA* expression and DNA supercoiling. *J Bacteriol* 171:6573–6579
- Galkin AN, Mikheeva LE, Shestakov SV (2003) Insertional inactivation of genes encoding eukaryotic-type serine/threonine protein kinases in the cyanobacterium *Synechocystis* sp. PCC 6803. *Mikrobiologiya* 72:64–69
- Gellert M, O’Dea MH, Itoh T, Tomizawa J (1976) Novobiocin and coumermycin inhibit DNA supercoiling catalyzed by DNA gyrase. *Proc Natl Acad Sci USA* 73:4474–4478
- Gilmour D, Gellert M (1961) The binding of *p*-chloromercuribenzoate by myosin. *Arch Biochem Biophys* 93:605–616
- Glatz A, Vass I, Los DA, Vigh L (1999) The *Synechocystis* model of stress: from molecular chaperons to membranes. *Plant Physiol Biochem* 37:1–12
- Graeme-Cook KA, May G, Bremer E, Higgins CF (1989) Osmotic regulation of porin expression: a role for DNA supercoiling. *Mol Microbiol* 3:1287–1294
- Grau R, Gardiol D, Glikin GC, de Mendoza D (1994) DNA supercoiling and thermal regulation of unsaturated fatty acid synthesis in *Bacillus subtilis*. *Mol Microbiol* 11:933–941
- Haselkorn R (1991) Genetic systems in cyanobacteria. *Methods Enzymol* 204:418–430
- Hecker M, Schumann W, Volker U (1996) Heat-shock and general stress response in *Bacillus subtilis*. *Mol Microbiol* 19:417–428
- Higgins CF, Dorman CJ, Stirling DA, Waddell L, Booth IR, May G, Bremer E (1988) A physiological role for DNA supercoiling in the osmotic regulation of gene expression in *S. typhimurium* and *E. coli*. *Cell* 52:569–584
- Hirani TA, Suzuki I, Murata N, Hayashi H, Eaton-Rye JJ (2001) Characterization of a two-component signal transduction system involved in the induction of alkaline phosphatase under phosphate-limiting conditions in *Synechocystis* sp. PCC 6803. *Plant Mol Biol* 45:133–144
- Hsiao HY, He Q, Van Waasbergen LG, Grossman AR (2004) Control of photosynthetic and high light-responsive genes by the histidine kinase DspA: negative and positive regulation and interactions between signal transduction pathways. *J Bacteriol* 186:3882–3888
- Hübschmann T, Yamamoto H, Gieler T, Murata N, Börner T (2005) Red and far-red light alter the transcript profile in the cyanobacterium *Synechocystis* sp. PCC 6803: impact of cyanobacterial phytochromes. *FEBS Lett* 579:1613–1618
- Hughes J, Lamparter T, Mittmann F, Hartmann E, Gartner W, Wilde A, Boerner T (1997) A prokaryotic phytochrome. *Nature* 386:663
- Hulko M, Berndt F, Gruber M, Linder JU, Truffault V, Schultz A, Martin J, Schultz JE, Lupas AN, Coles M

- (2006) The HAMP domain structure implies helix rotation in transmembrane signaling. *Cell* 126:929–940
- Inaba M, Suzuki I, Szalontai B, Kanesaki Y, Los DA, Hayashi H, Murata N (2003) Gene-engineered rigidification of membrane lipids enhances the cold inducibility of gene expression in *Synechocystis*. *J Biol Chem* 278:12191–12198
- Iwasaki H, Williams SB, Kitayama Y, Ishiura M, Golden SS, Kondo T (2000) A *kaiC*-interacting sensory histidine kinase, SasA, necessary to sustain robust circadian oscillation in cyanobacteria. *Cell* 101:223–233
- Jorissen HJ, Quest B, Remberg A, Coursin T, Braslavsky SE, Schaffner K, Tandeau de Marsac N, Gartner W (2002) Two independent, light-sensing, two-component systems in a filamentous cyanobacterium. *Eur J Biochem* 269:2662–2671
- Jung K, Veen M, Altendorf K (2000) K<sup>+</sup> and ionic strength directly influence the autophosphorylation activity of the putative turgor sensor KdpD of *Escherichia coli*. *J Biol Chem* 275:40142–40147
- Juntarajumnong W, Hirani TA, Simpson JM, Incharoensakdi A, Eaton-Rye JJ (2007) Phosphate sensing in *Synechocystis* sp. PCC 6803: SphU and the SphS-SphR two-component regulatory system. *Arch Microbiol* 188:389–402
- Kamei A, Yuasa T, Orikawa K, Geng XX, Ikeuchi M (2001) A eukaryotic-type protein kinase, SpkA, is required for normal motility of the unicellular cyanobacterium *Synechocystis* sp. strain PCC 6803. *J Bacteriol* 183:1505–1510
- Kamei A, Yoshihara S, Yuasa T, Geng X, Ikeuchi M (2003) Biochemical and functional characterization of a eukaryotic-type protein kinase, SpkB, in the cyanobacterium *Synechocystis* sp. PCC 6803. *Curr Microbiol* 46:296–301
- Kaneko T, Sato S, Kotani H, Tanaka A, Asamizu E, Nakamura Y, Miyajima N, Hirosawa M, Sugiura M, Sasamoto S, Kimura T, Hosouchi T, Matsuno A, Muraki A, Nakazaki N, Naruo K, Okumura S, Shimpo S, Takeuchi C, Wada T, Watanabe A, Yamada M, Yasuda M, Tabata S (1996) Sequence analysis of the genome of the unicellular cyanobacterium *Synechocystis* sp. strain PCC6803. II. Sequence determination of the entire genome and assignment of potential protein-coding regions. *DNA Res* 3:185–209
- Kaneko T, Nakamura Y, Sasamoto S, Watanabe A, Kohara M, Matsumoto M, Shimpo S, Yamada M, Tabata S (2003) Structural analysis of four large plasmids harboring in a unicellular cyanobacterium, *Synechocystis* sp. PCC 6803. *DNA Res* 10:221–228
- Kanesaki Y, Suzuki I, Allakhverdiev SI, Mikami K, Murata N (2002) Salt stress and hyperosmotic stress regulate the expression of different sets of genes in *Synechocystis* sp. PCC 6803. *Biochem Biophys Res Commun* 290:339–348
- Kanesaki Y, Yamamoto H, Paithoonrangsarid K, Shoumskaya M, Suzuki I, Hayashi H, Murata N (2007) Histidine kinases play important roles in the perception and signal transduction of H<sub>2</sub>O<sub>2</sub> in the cyanobacterium *Synechocystis*. *Plant J* 49:313–324
- Kappel AD, van Waasbergen LG (2007) The response regulator RpaB binds the high light regulatory 1 sequence upstream of the high light-inducible *hliB* gene from the cyanobacterium *Synechocystis* PCC 6803. *Arch Microbiol* 187:337–342
- Keohoe DM, Grossman AR (1994) Complementary chromatic adaptation: photoperception to gene regulation. *Semin Cell Biol* 5:303–313
- Keohoe DM, Grossman AR (1996) Similarity of a chromatic adaptation sensor to phytochrome and ethylene receptors. *Science* 273:1409–1412
- Koretke KK, Lupas AN, Warren PV, Rosenberg M, Brown JR (2000) Evolution of two-component signal transduction. *Mol Biol Evol* 17:1956–1970
- Leonard CJ, Aravind L, Koonin EV (1998) Novel families of putative protein kinases in bacteria and archaea: evolution of the “eukaryotic” protein kinase superfamily. *Genome Res* 8:1038–1047
- Li H, Sherman LA (2000) A redox-responsive regulator of photosynthesis gene expression in the cyanobacterium *Synechocystis* sp. strain PCC 6803. *J Bacteriol* 182:4268–4277
- Lopez-Maury L, Garcia-Dominguez M, Florencio FJ, Reyes JC (2002) A two-component signal transduction system involved in nickel sensing in the cyanobacterium *Synechocystis* sp. PCC 6803. *Mol Microbiol* 43:247–256
- López-Maury L, Florencio FJ, Reyes JC (2003) Arsenic sensing and resistance system in the cyanobacterium *Synechocystis* sp. strain PCC 6803. *J Bacteriol* 185:5363–5371
- Los DA (2004) The effect of low-temperature-induced DNA supercoiling on the expression of the desaturase genes in *Synechocystis*. *Cell Mol Biol* 50:605–612
- Los DA, Murata N (1999) Responses to cold shock in cyanobacteria. *J Mol Microbiol Biotechnol* 1:221–230
- Los DA, Murata N (2000) Regulation of enzymatic activity and gene expression by membrane fluidity. *Science's Signal Transduction Knowledge Environment* 62: PE1. [http://www.stke.org/cgi/content/full/OC\\_sigtrans;2000/62/pe1](http://www.stke.org/cgi/content/full/OC_sigtrans;2000/62/pe1)
- Los DA, Murata N (2002) Sensing and response to low temperature in cyanobacteria. In: Storey KB, Storey JM (eds) *Cell and molecular responses to stress, sensing, signaling and cell adaptation*, vol 3. Elsevier, Amsterdam, pp 139–153
- Los DA, Murata N (2004) Membrane fluidity and its roles in the perception of environmental signals. *Biochim Biophys Acta* 1666:142–157
- Marin K, Suzuki I, Yamaguchi K, Ribbeck K, Yamamoto H, Kanesaki Y, Hagemann M, Murata N (2003) Identification of histidine kinases that act as sensors in the perception of salt stress in *Synechocystis* sp. PCC 6803. *Proc Natl Acad Sci USA* 100:9061–9066



- Mikami K, Murata N (2003) Membrane fluidity and the perception of environmental signals in cyanobacteria and plants. *Prog Lipid Res* 42:527–543
- Mikami K, Kanesaki Y, Suzuki I, Murata N (2002) The histidine kinase Hik33 perceives osmotic stress and cold stress in *Synechocystis* sp. PCC 6803. *Mol Microbiol* 46:905–915
- Mizuno T, Kaneko T, Tabata S (1996) Compilation of all genes encoding bacterial two-component signal transducers in the genome of the cyanobacterium *Synechocystis* sp. strain PCC 6803. *DNA Res* 3:407–414
- Murata N, Los DA (2006) Histidine kinase Hik33 is an important participant in cold signal transduction in cyanobacteria. *Physiol Plant* 126:17–27
- Murata N, Suzuki I (2006) Exploitation of genomic sequences in a systematic analysis to access how cyanobacteria sense environmental stress. *J Exp Bot* 57:235–247
- Murata N, Wada H (1995) Acyl-lipid desaturases, their importance in the tolerance and acclimatization to cold of cyanobacteria. *Biochem J* 308:1–8
- Nakamoto H, Suzuki M, Kojima K (2003) Targeted inactivation of the *hrcA* repressor gene in cyanobacteria. *FEBS Lett* 549:57–62
- Ogawa T, Bao DH, Katoh H, Shibata M, Pakrasi HB, Bhattacharyya-Pakrasi M (2002) A two-component signal transduction pathway regulates manganese homeostasis in *Synechocystis* 6803, a photosynthetic organism. *J Biol Chem* 277:28981–28986
- Okamoto S, Ikeuchi M, Ohmori M (1999) Experimental analysis of recently transposed insertion sequences in the cyanobacterium *Synechocystis* sp. PCC 6803. *DNA Res* 6:265–273
- Osanai T, Kanesaki Y, Nakano T, Takahashi H, Asayama M, Shirai M, Kanehisa M, Suzuki I, Murata N, Tanaka K (2005) Positive regulation of sugar catabolic pathways in the cyanobacterium *Synechocystis* sp. PCC 6803 by the group 2 sigma factor sigE. *J Biol Chem* 280:30653–30659
- Paithoonrangsarid K, Shoumskaya MA, Kanesaki Y, Satoh S, Tabata S, Los DA, Zinchenko VV, Hayashi H, Tanticharoen M, Suzuki I, Murata N (2004) Five histidine kinases perceive osmotic stress and regulate distinct sets of genes in *Synechocystis*. *J Biol Chem* 279:53078–53086
- Panichkin VB, Arakawa-Kobayashi S, Kanaseki T, Suzuki I, Los DA, Shestakov SV, Murata N (2006) Serine/threonine protein kinase, SpkA, in *Synechocystis* sp. PCC 6803 is a regulator of expression of three putative *pilA* operons, formation of thick pili and cell motility. *J Bacteriol* 188:7696–7699
- Schmitz O, Katayama M, Williams SB, Kondo T, Golden SS (2000) CikA, a bacterio-phytochrome, that resets the cyanobacterial circadian clock. *Science* 289:765–768
- Shi L, Potts M, Kennelly PJ (1998) The serine, threonine and/or tyrosine-specific protein kinases and protein phosphatases of prokaryotic organisms: A family portrait. *FEMS Microbiol Rev* 22:229–253
- Shoumskaya MA, Paithoonrangsarid K, Kanesaki Y, Los DA, Zinchenko VV, Tanticharoen M, Suzuki I, Murata N (2005) Identical Hik-Rre systems are involved in perception and transduction of salt signals and hyperosmotic signals but regulate the expression of individual genes to different extents in *Synechocystis*. *J Biol Chem* 80:21531–21538
- Sineshchekov V, Hughes J, Hartmann E, Lamparter T (1998) Fluorescence and photochemistry of recombinant phytochrome from the cyanobacterium *Synechocystis*. *Photochem Photobiol* 67:263–267
- Sineshchekov OA, Trivedi VD, Sasaki J, Spudich JL (2005) Photochromicity of *Anabaena* sensory rhodopsin, an atypical microbial receptor with a *cis*-retinal light-adapted form. *J Biol Chem* 280:14663–14668
- Stock AM, Robinson VL, Goudreau PN (2000) Two-component signal transduction. *Annu Rev Biochem* 69:183–215
- Suzuki I, Los DA, Kanesaki Y, Mikami K, Murata N (2000) The pathway for perception and transduction of low-temperature signals in *Synechocystis*. *EMBO J* 19:1327–1334
- Suzuki I, Kanesaki Y, Mikami K, Kanehisa M, Murata N (2001) Cold-regulated genes under control of the cold sensor Hik33 in *Synechocystis*. *Mol Microbiol* 40:235–244
- Suzuki S, Ferjani A, Suzuki I, Murata N (2004) The SphS-SphR two component system is the exclusive sensor for the induction of gene expression in response to phosphate limitation in *Synechocystis*. *J Biol Chem* 279:13234–13240
- Suzuki I, Kanesaki Y, Hayashi H, Hall JJ, Simon WJ, Slabas AR, Murata N (2005) The histidine kinase Hik34 is involved in thermotolerance by regulating the expression of heat-shock genes in *Synechocystis*. *Plant Physiol* 138:1409–1421
- Szalontai B, Nishiyama Y, Gombos Z, Murata N (2000) Membrane dynamics as seen by Fourier Transform Infrared Spectroscopy in a cyanobacterium, *Synechocystis* PCC 6803: The effects of lipid unsaturation and the protein-to-lipid ratio. *Biochim Biophys Acta* 1509:409–419
- Takai N, Nakajima M, Oyama T, Kito R, Sugita C, Sugita M, Kondo T, Iwasaki H (2006) A KaiC-associating SasA-RpaA two-component regulatory system as a major circadian timing mediator in cyanobacteria. *Proc Natl Acad Sci USA* 103:12109–12114
- Tao W, Malone CL, Ault AD, Deschenes RJ, Fassler JS (2002) A cytoplasmic coiled-coil domain is required for histidine kinase activity of the yeast osmosensor SLN1. *Mol Microbiol* 43:459–473
- Tasaka Y, Gombos Z, Nishiyama Y, Mohanty P, Ohba T, Ohki K, Murata N (1996) Targeted mutagenesis of acyl-lipid desaturases in *Synechocystis*: Evidence for the important roles of polyunsaturated membrane lipids in growth, respiration and photosynthesis. *EMBO J* 15:6416–6425
- Taylor BL, Zhulin IB (1999) PAS domains: internal sensors of oxygen, redox potential and light. *Microbiol Mol Biol Rev* 63:479–506

- Tu CJ, Shrager J, Burnap RL, Postier BL, Grossman AR (2004) Consequences of a deletion in *dspA* on transcript accumulation in *Synechocystis* sp. strain PCC 6803. *J Bacteriol* 186:3889–3902
- van Waasbergen LG, Dolganov N, Grossman AR (2002) *nblS*, a gene involved in controlling photosynthesis-related gene expression during high light and nutrient stress in *Synechococcus elongatus* PCC 7942. *J Bacteriol* 184:2481–2490
- Vermaas WF (1998) Gene modifications and mutation mapping to study the function of photosystem II. *Methods Enzymol* 297:293–310
- Vogelez L, Sineshchekov OA, Trivedi VD, Sasaki J, Spudich JL, Luecke H (2004) *Anabaena* sensory rhodopsin: a photochromic color sensor at 2.0 Å. *Science* 306:1390–1393
- Walderhaug MO, Polarek JW, Voelkner P, Daniel JM, Hesse JE, Altendorf K, Epstein W (1992) KdpD and KdpE, proteins that control expression of the *kdpABC* operon, are members of the two-component sensor-effector class of regulators. *J Bacteriol* 174:2152–2159
- Wang HL, Postier BL, Burnap RL (2004a) Alterations in global patterns of gene expression in *Synechocystis* sp. PCC 6803 in response to inorganic carbon limitation and the inactivation of *ndhR*, a LysR family regulator. *J Biol Chem* 279:5739–5751
- Wang JC, Lynch AS (1993) Transcription and DNA supercoiling. *Curr Opin Genet Dev* 3:764–768
- Wang T, Shen G, Balasubramanian R, McIntosh L, Bryant DA, Golbeck JH (2004b) The *sufR* gene (*sll0088* in *Synechocystis* sp. strain PCC 6803) functions as a repressor of the *sufBCDS* operon in iron-sulfur cluster biogenesis in cyanobacteria. *J Bacteriol* 186:956–967
- Weinstein-Fischer D, Elgrably-Weiss M, Altuvia S (2000) *Escherichia coli* response to hydrogen peroxide: a role for DNA supercoiling, topoisomerase I and Fis. *Mol Microbiol* 35:1413–1420
- Widmann C, Gibson S, Jarpe MB, Johnson GL (1999) Mitogen activated protein kinase: conservation of a three-kinase module from yeast to human. *Physiol Rev* 79:143–180
- Wilde A, Churin Y, Schubert H, Boerner T (1997) Disruption of a *Synechocystis* sp. PCC 6803 gene with partial similarity to phytochrome genes alters growth under changing light qualities. *FEBS Lett* 406:89–92
- Williams JGK (1988) Construction of specific mutations in Photosystem II photosynthetic reaction center by genetic engineering methods in *Synechocystis* PCC6803. *Methods Enzymol* 167:766–778
- Williams SB, Stewart V (1999) Functional similarities among two-component sensors and methyl-accepting chemotaxis proteins suggest a role for linker region amphipathic helices in transmembrane signal transduction. *Mol Microbiol* 33:1093–1102
- Yamaguchi K, Suzuki I, Yamamoto H, Lyukevich A, Bodrova I, Los DA, Piven I, Zinchenko V, Kanehisa M, Murata N (2002) A two-component Mn<sup>2+</sup>-sensing system negatively regulates expression of the *mntCAB* operon in *Synechocystis*. *Plant Cell* 14:2901–2913
- Yeh KC, Wu SH, Murphy JT, Lagarias JC (1997) A cyanobacterial phytochrome two-component light-sensory system. *Science* 277:1505–1508
- Zabulon G, Richaud C, Guidi-Rontani C, Thomas JC (2007) *NblA* gene expression in *Synechocystis* PCC 6803 strains lacking DspA (Hik33) and an NblR-like protein. *Curr Microbiol* 54:36–41
- Zhang CC, Gonzalez L, Phalip V (1998) Survey, analysis and genetic organization of genes encoding eukaryotic-like signaling proteins on a cyanobacterial genome. *Nucleic Acids Res* 26:3619–3625
- Zhang CC, Jang J, Sakr S, Wang L (2005) Protein phosphorylation on Ser, Thr and Tyr residues in cyanobacteria. *J Mol Microbiol Biotechnol* 9:154–166



# Chapter 3

## Stress Signaling I: The Role of Abscisic Acid (ABA)

Christopher D. Rock  
*Department of Biological Sciences, Texas Tech University,  
Lubbock, TX, 79409-3131, USA*

Yoichi Sakata  
*Department of Bio-Science, Laboratory of Plant Genetics,  
Tokyo University of Agriculture, Tokyo, 156-8502, Japan*

Ralph S. Quatrano\*  
*Department of Biology, Washington University in St. Louis, MO, 63130-4899, USA*

Summary .....	34
I Introduction .....	35
II Initial Perception of the Stress .....	35
III ABA Receptors .....	36
A G Protein-Coupled Receptor-Like Protein .....	36
B Genomes Uncoupled 5/Mg Chelatase H (GUN5/CHLH) .....	37
C Flowering Control Locus A (FCA) .....	38
D ABA Receptors in Animals .....	39
IV Transduction of the Stress Signal .....	39
A Second Messengers .....	39
B MAPK Signaling Components .....	41
C Sucrose Non-fermenting-Related Protein Kinase 2 (SnRK2) Proteins .....	41
D Phosphatases .....	42
E Protein Modification .....	43
V Regulation of Abiotic Stresses at the Level of Gene Expression .....	44
A Cis-Acting Elements for ABA-dependent Gene Expression .....	44
VI Responses to Temperature Stresses .....	46
A Cold Stress Responses .....	46
B Heat Stress Responses .....	48
VII Cross-Talk Between Abiotic and Biotic Stress Responses .....	49
VIII Regulation of ABA Metabolism .....	54
Acknowledgements .....	57
References .....	57

---

\* Author for Correspondence, e-mail: [rsq@wustl.edu](mailto:rsq@wustl.edu)

## Summary

This review concentrates on two aspects of how ABA is involved with the adaptation of plants to abiotic stress: (a) the perception of the stress and the resulting ABA response network of intermediates that transduce the signal to trigger gene expression, and (b) the control of ABA metabolism itself that governs the levels of ABA in cells and tissues. Given the importance of abiotic stresses in limiting crop yields, both of these control points, i.e., the ABA signaling pathways and ABA levels, are critical targets with potential for genetic engineering to enhance crop production and impact sustainable agriculture as global warming takes hold and further alters the environment. Increased knowledge of the details has revealed complex crosstalk between networks of multiple hormonal and stress response pathways, prompting the need for more systems level and comparative genomics approaches. Natural variation offers a means to identify genes responsible for quantitative trait locus (QTL) effects on stress adaptation in plants (<http://1001genomes.org>). Such a catalogue of genetic variation would accelerate comparative genomics of signaling networks and the identification of QTL genes for ABA-mediated stress responses, providing insights into how plants have evolved their ABA networks to adapt to diverse natural environments. Future studies could use whole-genome transcriptome approaches and homologous recombination in the model basal plant *Physcomitrella* to dissect the complex networks involved in ABA-related stress pathways. Identification of ABA receptors has not been completely resolved at this time, but future emphasis and dedication to clarify this elusive signaling step for the last member of the “big five” hormones is essential for any future understanding of stress responses. Overall, we can expect strong experimental contributions to our continued understanding of the ABA response pathway and ABA metabolism in the next decade.

**Keywords** Abscisic acid metabolism • gene expression • hormone receptors • seed development • signal transduction • stomatal response • stress adaptation • systems biology

---

*Abbreviations:* *aba* – ABA deficient; ABA – abscisic acid; *abh* – ABA hypersensitive; ABI – ABA insensitive; ABRE – ABA responsive element; *adr* – activated disease resistance; AFP – ABA-insensitive five binding protein; *ahg* – ABA hypersensitive to germination; ANACs – ABA-responsive NACs; AtHK – *A. thaliana* hybrid-type histidine kinase; AtMKP1 – MAPK phosphatase 1; AtVSR – *Arabidopsis* vacuolar sorting receptor; bZIP – basic leucine zipper; CAS – Ca<sup>2+</sup> sensing receptor; CBF – C-repeat binding factors; COR – cold-responsive; CRT – C-repeat element; CSPs – cold-stress-inducible proteins; DDB1 – UV-damaged DNA binding protein-1; *det1* – de-etiolated-1; DGK – diacylglycerol kinase; DRE – drought-responsive element; DREB – dehydration-responsive element-binding protein; *eds* – enhanced disease susceptibility; *era* – enhanced response to ABA; ERE – ethylene responsive element; ERF/AP2 – ethylene response factor/APETELA2; *esk* – eskimo; *fca* – flowering control locus *A*; *fld* – flowering locus D; FLS2 – flagellin receptor; GAs – gibberellins; GCL – *GCR2*-like; GCR – G protein-coupled receptor-like protein; GPA – G protein  $\alpha$  subunit; GPX – glutathione peroxidase; GSNOR – S-nitrosoglutathione reductase; HAB – homology to ABI1/2 H<sub>2</sub>O<sub>2</sub> – hydrogen peroxide; *hos* – high osmotic stress; *hot* – sensitive

to hot temperatures; HSPs – heat shock proteins; *hsr* – high sugar response; HXK – hexokinase; *ice* – inducer of CBF expression; ICMT – isoprenyl cysteine methyltransferase; IP<sub>3</sub> – inositol 1,4,5-triphosphate; JA – jasmonic acid; LEA – late embryogenesis abundant; LRR – leucine-rich repeat protein; LSD – lysine-specific demethylase; MAPK – mitogen-activated protein kinase; MAPKK – mitogen-activated protein kinase kinase; MBF1c – multiprotein bridging factor 1c; *NCED* – nine-cis-epoxycarotenoid dioxygenase; NO – nitric oxide; PA – phosphatidic acid; PIPs – plasma membrane intrinsic proteins; PLC – phospholipase C; PLD – phospholipase D; *plp* – pluripetala; PM – plasma membrane; PP2C – protein phosphatase 2C; PPR – pentatricopeptide repeat; PSY3 – phytoene synthase paralogue; QTL – quantitative trait locus; ; RLK – receptor-like kinases; RLP – receptor-like protein; RNAi – RNA interference; ROS – reactive oxygen species; RPK – leucine-rich-repeat receptor kinase; RSRE – rapid stress response element; SA – salicylic acid; SAP – stress associated protein; siRNA – small interfering RNA; SnRK – sucrose non-fermenting-related protein kinase; *SOS* – salt overly sensitive; TDIF – tracheary element differentiation inhibitory factor; TPS – trehalose phosphate synthase; *vp* – viviparous; XLGs – extra-large G proteins

## I Introduction

Plants are sessile and have evolved an open, plastic mode of growth via complex overlapping pathways to integrate responses to drought, salt, cold, as well as hormonal cues such as abscisic acid (ABA). Transcriptional profiling studies in model species have revealed that 8–10% of plant genomes are either induced or repressed by ABA at a single developmental stage. The challenge to biotechnology in the post-genomics era is to understand and discriminate the regulation and function of sequences and translate that knowledge into cogent strategies for affecting plant function (Cove 2005; Zhang et al. 2005; Quatrano et al. 2007; Khandelwal et al. 2008).

Abiotic stress tolerance is a complex trait with large gaps in our understanding of the molecular details. A phytohormone that plays a fundamental role in stress adaptation is abscisic acid (ABA), a small lipophilic sesquiterpenoid (C<sub>15</sub>) that also plays important roles in plant growth and development. A detailed knowledge of ABA metabolism, sites of ABA perception and delivery of ABA to physiological sites of action is the key to developing strategies for coping with abiotic stresses for sustainable agriculture. The pioneering studies in the 1960s on ABA, originally called “dormin” and “abscisin”, established that ABA accumulates in over-wintering buds and in immature cotton bolls that succumbed to auxin- and ethylene-triggered abscission. It was later elucidated that under these conditions plants at these stages of development were experiencing drought stress. Thus, ABA is literally a misnomer (Addicott and Carns 1983), even though it (ironically) does play roles in dormancy in seeds and leaf senescence, probably via osmotic effects (Pourtau et al. 2004; Rivero et al. 2007; Carrera et al. 2008). During the last few decades, water-stressed vegetative tissues of many plants have been shown to exhibit up to 40-fold increase in ABA levels within hours after experiencing water stress and then a decrease after water balance is restored. Since ABA has also been hypothesized as a long-distance stress signal between root and shoot, the tissue-specific regulation of genes controlling rate-limiting steps of ABA metabolism is an important aspect of understanding stress adaptation in plants. Beyond abiotic stress adaptation, ABA has been implicated as playing a key role

in pathogen virulence (de Torres-Zabala et al. 2007; Asselbergh et al. 2008), which may provide insight into why many bio- and necrotrophic microbes have evolved the ability to synthesize ABA (Siewers et al. 2006; Asselbergh et al. 2008; Cohen et al. 2008; Goel et al. 2008). We will review recent progress in understanding ABA and stress perception that are integrated into the cellular and intercellular networks of environmental and developmental pathways leading to stress adaptation, and summarize what is known about regulation of ABA metabolism, a parallel target for cogent strategies to affect crop stress tolerance. Other recent reviews cover specific aspects of ABA responses in more detail (Finkelstein et al. 2008; McCourt and Creelman 2008; Suzuki and McCarty 2008; Wang and Zhang 2008).

## II Initial Perception of the Stress

Gene products acting in or at the cell wall as well as at the interface of the cell wall/plasma membrane and plasma membrane/cytoskeleton are likely candidates in the initial perception of the stress. For example, osmo- and mechanosensitive ion channels and gated aquaporins (plasma membrane intrinsic proteins, PIPs) at the plasma membrane (PM)-cell wall interface may be involved (Jang et al. 2004; Cui et al. 2008; Kaldenhoff et al. 2008). Genes induced by hypobarica confirm that water movement is a paramount issue at low atmospheric pressures, because many gene products intersect ABA-related, drought-induced pathways (Paul et al. 2004). Insights between ABA and osmotic stress perception have come from studies of the two-component histidine kinases AtHK-1, -2, -3, -4/CRE/WOODEN LEG and -5/CKI2 (Osakabe et al. 2005; Iwama et al. 2007; Tran et al. 2007). The roles of ABA in plant morphogenesis (van Hengel et al. 2004; Barrero et al. 2005; Lumba and McCourt 2005) are only beginning to be elucidated and suggest that the cell wall may play a role in stress perception/response. For example, arabinogalactan proteins are modulated by ABA (Johnson et al. 2003), and a monoclonal antibody (JIM19) antagonizes ABA-inducible gene expression and recognizes an arabinogalactan epitope at the plasma-membrane/cell-wall interface (Desikan et al. 1999). ABA-dependent callose accumulation

is required for  $\beta$ -amino-butyric acid-induced resistance to the pathogens *A. brassicicola* and *P. cumumerina* (Ton et al. 2005). A xyloglucan endotransglycosylase associated with hypocotyl elongation is down-regulated by ABA in mung bean (Yun et al. 2005). The cloning of *ABSCISIC ACID (ABA)-INSENSITIVE-8*, which is allelic to *ELONGATION DEFECTIVE-1* and *KOBITO-1*, establishes a link between ABA and the cell wall because mutations in this locus disrupt ABA-regulated gene expression, sugar sensitivity, cell elongation, cellulose synthesis, vascular differentiation, and root meristem maintenance (Brocard-Gifford et al. 2004). Similarly, the *HIGH SUGAR RESPONSE8 (HSR8)* gene is allelic to the *MURUS4 (MUR4)* gene involved in arabinose synthesis and the *hsr8* mutant phenotype can be rescued by boric acid, suggesting that alterations in the cell wall cause hypersensitive sugar-responsive phenotypes (Li et al. 2007). Mutation of the cellulose synthase *CESA8/ISOXABEN-RESISTANT1/LEAF-WILTING2* gene results in drought-, salt- and osmotic-stress resistance and elevated ABA-inducible gene expression (Chen et al. 2005).

Recently, Lue et al. (2007) demonstrated by immunoblotting and immunofluorescence a protein in *Zea mays* roots that is similar to the integrin proteins of animals and mainly localized in the plasma membrane. Treatment with GRGDS, a synthetic pentapeptide containing a RGD domain, which interacts specifically with the integrin protein and thus blocks the cell wall-plasma membrane interaction, significantly inhibits osmotic stress-induced ABA biosynthesis in cells. Characterization of mutants that have morphological phenotypes that affect stress tolerance will allow further dissection of how the perception of the stress and these cell wall/cytosol components interact.

### III ABA Receptors

#### A G Protein-Coupled Receptor-Like Protein

Several reports of ABA receptors have appeared recently (Finkelstein 2006; Grill and Christmann 2007; Razem and Hill 2007; Verslues and Zhu 2007; McCourt and Creelman 2008; Wang and Zhang 2008; Jones and Sussman 2009), but the apparent incongruence of their molecular identities with the rich literature on ABA physiology

and ensuing controversies have further complicated the already bewildering network of ABA responses. A G protein-coupled receptor-like protein (GCR2) was reported to genetically and physically interact with the G protein  $\alpha$  subunit GPA1 to mediate all known ABA responses in *Arabidopsis* (Liu et al. 2007c). Overexpressed GCR2 resulted in an ABA-hypersensitive phenotype and the purified protein bound ABA with high affinity at physiological concentrations with expected kinetics and stereospecificity. The binding of ABA to the protein led to the dissociation of the GCR2-GPA1 complex in yeast, providing direct evidence for a hypothesized ABA receptor previously based on evidences for extracellular perception of ABA (reviewed in Rock 2000). However, contradictory results to Liu et al. (2007c) were subsequently reported that loss-of-function mutations in three *gcr2* mutant alleles and a GCR2-Like homolog *gcl1* had no ABA phenotypes or altered ABA-inducible marker gene expression in seedlings, even in *gcr2/gcl1* double and *gcr2/gcl1/gcl2* triple mutants (Gao et al. 2007; Guo et al. 2008). The authors challenging the GCR2 receptor hypothesis provided additional evidence that GCR2 is not genetically coupled to the sole heterotrimeric G $\alpha$  subunit GPA1, which along with REGULATOR OF G-PROTEIN RESPONSE (RGS) mediates ABA-inducible gene expression, germination responses and glucose signaling (Chen et al. 2006; Pandey et al. 2006; Johnston et al. 2007). Gao et al. go on to argue against GCR2 being an integral membrane protein based on computational predictions, and point out that the hypothesized positive ABA effector GCR2 does not fit logically with the consistent evidences for other heterotrimeric G protein  $\beta$  and  $\gamma$  subunits AGB1 and AGG1/2 and the RGS and Atpirin1 (PRN1) effectors being negative regulators of ABA responses (Lapik and Kaufman 2003; Trusov et al. 2007; Fan et al. 2008). Furthermore, the gene expression patterns of GCR2 do not correlate with other established ABA effectors or reporters. A technical comment on the Liu et al. (2007c) paper was also subsequently published arguing against GCR2 being a G-protein-coupled receptor (Johnston et al. 2007) based on structural and computational predictions that GCR2 is a plant homolog of bacterial lanthionine synthetases, a superfamily of genes that produce cyclized antimicrobial peptides. There is evidence for peripheral association of mammalian LanC orthologs with membranes, and Johnston



et al. reinterpret the protein-protein interaction and biochemical data of Liu et al. as inconsistent with GCR2 being an integral membrane protein or interacting physically with GPA1.

Liu et al. (2007d) rebutted by presenting biochemical and cell biological evidence to support their claims that GCR2 is a novel non-classical G protein-coupled receptor. Given the subtle phenotypes of the *ger2* and *gcl1* loss-of-function mutants and the contradictory reports, it is unclear at present whether GCR2 and its two homologs GCL1/2 are bona fide novel G protein modulators or ABA receptors. The situation is further complicated by genetic and biochemical evidence that GCR1, GPA1, PRN1 and nuclear factor Y heterotrimer affect ABA inhibition of germination and blue light signaling (Warpeha et al. 2007). The recent report showing that HY5 mediates light-dependent ABA responses in seeds and seedlings by binding the ABI5 promoter in an ABA-dependent manner sheds some light at least on the classical experiments on light requirements for seed germination in many species (Chen et al. 2008). Additional complexity comes from the characterization of three GPA1-homologous Extra-Large G proteins (XLGs) of *Arabidopsis* that affect ABA responses in roots and seeds (Ding et al. 2008). Like the (unconfirmed) landmark report of a plasma membrane-associated ABA receptor (Hornberg and Weiler 1984), and a later report of the perception of ABA at the cell surface (Schultz and Quatrano 1997), time will tell whether these G-proteins and effectors are at the nexus of ABA responses. The most recent ABA receptors to be reported, novel G-protein-coupled receptor-like (GPCR) proteins GTG1 and GTG2, were identified using bioinformatic approaches (Pandey et al. 2009), a method which is value-added but based on numerous assumptions. Taken in the context of ongoing controversies and a recent report showing that GCR2 does not bind ABA (Risk et al. 2009), these recent reports on G-protein-associated ABA activities underscore the need for improved methods for measuring ABA binding and application of strict biochemical criteria for receptor functionality.

### **B Genomes Uncoupled 5/Mg Chelatase H (GUN5/CHLH)**

GUN5/CHLH has been reported as an intracellular ABA receptor (Shen et al. 2006; Wang and

Zhang 2008), but it was originally isolated as a mutant that uncouples *LHCBI* transcription in the nucleus from plastid development (Mochizuki et al. 2001). There is a significant body of indirect evidence for intracellular ABA receptors and for ABA-binding proteins (reviewed in Rock 2000). In this case there is consistent genetic and physiological evidence supporting the saturable ABA binding results: reducing GUN5/CHLH levels through RNAi technology results in classic ABA phenotypes such as reduced seed dormancy and impaired leaf stomatal closure, and overexpression results in whole plant ABA-hypersensitive phenotypes (Shen et al. 2006; Wang and Zhang 2008). ABA down-regulates transcription of *RBCS* and *CAB* genes (Bartholomew et al. 1991; Chang and Walling 1991), consistent with a link between ABA perception and chloroplast development. ABA biosynthetic precursor xanthophylls are required for skotomorphogenesis (dark-grown “etiolation”) (Barrero et al. 2008) and ABA biosynthesis negatively controls plastid cell division in tomato (Galpaz et al. 2008). Tomato *high pigment1* (*hp1*) is ABA-inducible, and *hp1* and *hp2* genes of tomato encode UV-DAMAGED DNA BINDING PROTEIN-1 (DDB1) and DETIOLATED-1 (DET1) homologs, respectively, which are essential components of the recently identified CUL4-based E3 ligase complex. The APETELA2-Like transcription factor ABI4 has been implicated in retrograde signaling from chloroplast to nucleus (Koussevitzky et al. 2007). These recent findings are intriguing in the context of understanding the role of ABA in mechanisms of action of *gun5/chlf* and *gun1* genes. GUN1 is a chloroplast-localized pentatricopeptide-repeat protein that acts downstream of ABI4, which itself binds the promoter of a retrograde signaling-repressed gene through a conserved motif found in close proximity to a light-regulatory element (Koussevitzky et al. 2007). VARIEGATED3 is a part of a protein complex including the ABA biosynthetic enzyme NCED4 required for normal chloroplast and palisade cell development (Naested et al. 2004). Other genes (Mg protoporphyrin IX methyltransferase, *chlm* early light-induced protein2, e) that effect CHLH expression have been characterized as mediating plastid and chlorophyll biogenesis, but no other pleiotropic effects of knockouts of these genes on ABA responses have been described (Pontier et al. 2007; Tzvetkova-Chevolleau et al. 2007).

The apparent bifunctional role of CHLH in photosynthetic pigment biosynthesis and ABA responses remains a paradox, since ABA does not appear to change the enzymatic activity of the chelatase. Müller and Hansson (2009) have recently provided biochemical evidence arguing against CHLH as an ABA receptor.

### C Flowering Control Locus A (FCA)

A variety of ABA synthesis or response loci have been implicated in controlling meristem function or flowering time (Rock 2000; Finkelstein and Rock 2002). An ABA binding protein from barley aleurone ABAP1 (Razem et al. 2004) has significant homology to FLOWERING CONTROL LOCUS A (FCA) and homologs in *Arabidopsis*. Razem et al. (2006) claimed that saturable, stereospecific ABA binding by FCA exerted direct control on self-splicing of FCA pre-mRNA and downstream effects on the autonomous floral pathway mediated by the MADS box repressor protein FLOWERING LOCUS C (FLC). FCA downregulation of FLC expression requires FY, a homolog of the yeast RNA 3' processing factor Pfs2p, where FCA/FY physically interact and alter polyadenylation/3' processing to autoregulate FCA. It has recently been shown that FCA requires FLOWERING LOCUS D (FLD), a homolog of the human lysine-specific demethylase 1 (LSD1) and DICER-LIKE 3, involved in chromatin/transcriptional silencing by production of siRNAs (Liu et al. 2007a). Mutations in *fca* increase levels of unspliced sense FLC transcript, alter processing of antisense FLC transcripts and increase histone H3K4 dimethylation in the central region of FLC. The ABA hypersensitive mutants *hyponastic leaves1* (*hyl1*) and *ABA hypersensitive1* (*abh1*) are involved in miRNA metabolism (for *hyl1*) and mRNA 5' cap processing as well as miRNA and siRNA accumulation (Gregory et al. 2008) and exhibit altered flowering times (Lu and Fedoroff 2000; Bezerra et al. 2004; Kuhn et al. 2007), consistent with a role of ABA in the floral transition. Lateral root effects in the *fca-1* mutant (Macknight et al. 2002) are also consistent with a link between ABI3-, ABI1- and ABI2-related interactions with FCA (De Smet et al. 2006; Zhang et al. 2007b). However, negative results with *abi2* reported by Razem et al. 2006. contradicted the reported

phenotypes of early flowering observed in *abi1*, *abi2* and other ABA mutants (Martinez-Zapater 1994). It was interesting that Liu et al. (2007a), Bäurle et al. (2007) and a recent paper on the role of leucine-rich repeat receptor kinases in ABA signaling (Wang et al. 2008a) did not cite Razem et al. (2006). In contrast to the case of GCR2, the controversy over FCA as ABA receptor has been formally resolved with the very recent publication of negative results on ABA binding activity of FCA (Jang et al. 2008; Risk et al., 2008) and retraction of the original article (Razem et al. 2008). A 'knock-on' consequence noted by Risk et al. (2008) is GCR2-as-ABA-receptor has been cast further in doubt because Liu et al. (2007c) used FCA as a positive control in ABA-binding assays of GCR2. How ABA functions in these (Papp et al. 2004; Xiong et al. 2004; Gy et al. 2007; Zhao et al. 2007; Li et al. 2008c; Zhang et al. 2008) examples of post-transcriptional processing in stress and developmental pathways is not yet clear.

Another aspect of the ABA receptor odyssey is the incogruence of observed cellular concentrations of ABA (on the order of micromolar), which increase an order of magnitude during stress or development (Okamoto et al. 2006; McCourt and Creelman 2008), with the reported binding affinities of these putative receptors (low nanomolar). If GCR2 and CHLH are true ABA receptors, then ABA must have functions and mechanisms of action beyond the scope originally defined by traditional plant physiological and genetic studies. A sound theoretical framework is needed to guide hypothesis-driven experiments. A systems approach that holds promise is chemical genetics (Bassel et al. 2008) and exciting complementary biochemical and genetic results have been recently published that identify an ABA-agonist (pyrabactin, for pyridyl-containing ABA activators) and a new 14-member family of candidate ABA receptor proteins (PYR1/PYL, also named Regulatory Components of ABA Receptor [RCARs]) that physically interact with *ABA INSENSITIVE1/ABI2/HAB1* homologs to antagonize protein phosphatase (PP2C) activities in a ligand-dependent and stereospecific process (Ma et al. 2009; Park et al. 2009). Significantly, the activities *in vitro* on PP2Cs and *in planta* for ABA effects on gene expression, seed germination, stomatal aperture, and root growth of different



PYL/RCAR homologs are consistent with physiological concentrations of ABA (~100 nM) and impact some longstanding questions on subcellular perception sites of ABA, PP2C localization (Moes et al. 2008), and physiological effects of the unnatural (-) ABA isomer, as well as suggesting possible molecular mechanisms for PP2C roles in ABA-mediated chromatin remodeling (Saez et al. 2008) and Sucrose Non-fermenting-related Protein Kinase (SnRK) activities (Fujii et al. 2007; Mustilli et al. 2002; Yoshida et al. 2002). It appears that finally ABA may no longer be an orphan hormone.

#### D ABA Receptors in Animals

Recent reports have confirmed older (and skeptically received) works that ABA has physiological (e.g., anti-inflammatory, phagocytosis) effects in animals and is synthesized in protozoan parasites, cnidarians (hydroids, sponges and corals) and even mammalian brains ('Le Page de Givry et al. 1986). These advances suggest that interkingdom ABA and/or stress signaling may be evolutionarily conserved or laterally acquired and is biologically significant (Puce et al. 2004; Technau et al. 2005; Bruzzone et al. 2007; Guri et al. 2007; Nagamune et al. 2008). For example, an apparent plant-like ABA biosynthetic pathway in *Toxoplasma gondii* is targeted by a specific inhibitor of ABA synthesis which can prevent toxoplasmosis in a mouse model (Nagamune et al. 2008). More recently, ABA has been reported as an endogenous stimulator of insulin secretion in human and murine pancreatic beta cells (Bruzzone et al. 2008). These amazing findings open a whole new field of ABA metabolism/signaling in animals that may have significance for human health.

### IV Transduction of the Stress Signal

Abiotic stresses cause many changes in cellular signaling components. Various studies suggest that there are ABA-dependent and ABA-independent pathways in abiotic stress responses. ABA plays a major role in hyperosmotic stresses caused by high salinity and drought (Finkelstein et al. 2002). Hyperosmotic stress triggers ABA biosynthesis, which leads to changes in gene

expression through signaling networks. Similar to ABA receptors, understanding of signaling cascades downstream of ABA is still fragmentary but gaps are closing and new vistas opening.

#### A Second Messengers

Stomatal closure induced by ABA has been used as a model system for studying rapid (millisecond to second time frame) responses to ABA. Hyperosmotic stresses as well as ABA induce increases in phospholipids, reactive oxygen species (ROS), calcium and nitric oxide (NO) (Miller et al. 2008; Neill et al. 2008). These molecules act as "second messengers" in signaling networks for stomatal closure.

An increase in inositol 1,4,5-triphosphate ( $IP_3$ ) that is catalyzed by phospholipase C (PLC) induces an increase in cytosolic  $Ca^{2+}$  concentration, a key step in stomatal closure (Takahashi et al. 2001).  $IP_3$  is known to activate vacuolar calcium channels (Allen et al. 1995). Recently, chloroplast-localized  $Ca^{2+}$  sensing receptor (CAS) has been shown to play an important role in the generation of extracellular  $Ca^{2+}$ -induced cytosolic  $Ca^{2+}$  transients and stomatal closure in *Arabidopsis* by regulating concentrations of  $IP_3$ , which in turn directs release of  $Ca^{2+}$  from internal stores (Han et al. 2003; Tang et al. 2007; Nomura et al. 2008). However, *cas* knockout mutant lines showed normal ABA-induced stomatal closure, suggesting that CAS is not downstream of ABA signaling. Another phospholipid, phosphatidic acid (PA), which is produced by the action of phospholipase D (PLD), also has an important role in ABA signaling. Both PLC-DGK (diacylglycerol kinase) and PLD pathways have been implicated in plant stress responses (Testerink and Munnik 2005; Hong et al. 2008). Among PLDs,  $PLD\alpha_1$  seems to play a role in ABA signaling because its production is induced by ABA, and inhibition of  $PLD\alpha_1$  diminished stomatal closure induced by ABA (Zhang et al. 2004), whereas  $PLD\alpha_3$  is primarily involved in salt- and water deficit stress (Hong et al. 2008). A molecular function of PA has been shown for the regulation of ABA-induced stomatal closure.  $PLD\alpha_1$ -produced PA binds to ABI1, a protein phosphatase acting as a negative regulator of ABA signaling, and inhibits its activity, thus promoting ABA signaling (Mishra et al. 2006). Recent results on RNAi knockdown lines for the *Arabidopsis vacuolar*

*sorting receptor3* (*Atvsr3*) implicate the targeting of soluble cargo proteins in guard cells to elevated accumulation of NO and hydrogen peroxide ( $H_2O_2$ ) and decreased responsiveness of guard cells to ABA (Avila et al. 2008).

ABA is known to trigger the production of  $H_2O_2$  that activates ROS signaling processes which can be viewed as a node in a network linking various stresses. ABA-induced production of  $H_2O_2$  requires NAD(P)H, suggesting the involvement of NAD(P)H oxidases (Murata et al. 2001; Neill et al. 2008). Two catalytic subunit genes encoding NAD(P)H oxidases (*AtrbohD* and *AtrbohF*) are highly expressed in guard cells and expression of both mRNAs is upregulated by ABA. *atrbohD/F* double mutations impair ABA-induced stomatal closing and ABA promotion of ROS production (Kwak et al. 2003). This ROS signaling activates plasma membrane  $Ca^{2+}$  channels in guard cells, which promotes stomatal closure (Fig. 1). The ABA-induced ROS can also activate the antioxidant defense genes in leaves of maize (Guan et al.

2000). An increasing body of evidence indicates that NO is an endogenous signal in plants that mediates responses to environmental stimuli (Besson-Bard et al. 2008). The *HOT5* (sensitive to hot temperatures) gene is required for thermotolerance and encodes S-NITROSOGLUTATHIONE REDUCTASE (GSNOR), which metabolizes the NO adduct S-nitrosoglutathione (Lee et al. 2008b). Exogenous NO induces stomatal closure (Garcia-Mata and Lamattina 2002), and ABA triggers NO production that is dependent on  $H_2O_2$  production (Bright et al. 2006). This scheme (Fig. 1) has been recently extended to the induction of antioxidant defense in maize mesophyll cells (Zhang et al. 2007a, b). Insertion mutations inactivating a mitochondrial pentatricopeptide repeat (PPR) domain protein PPR40 associated with Complex III of the electron transport chain result in semidwarf growth habit and enhanced sensitivity to salt, ABA and oxidative stress, suggesting a close link between regulation of oxidative respiration and environmental adaptation (Zsigmond et al. 2008).

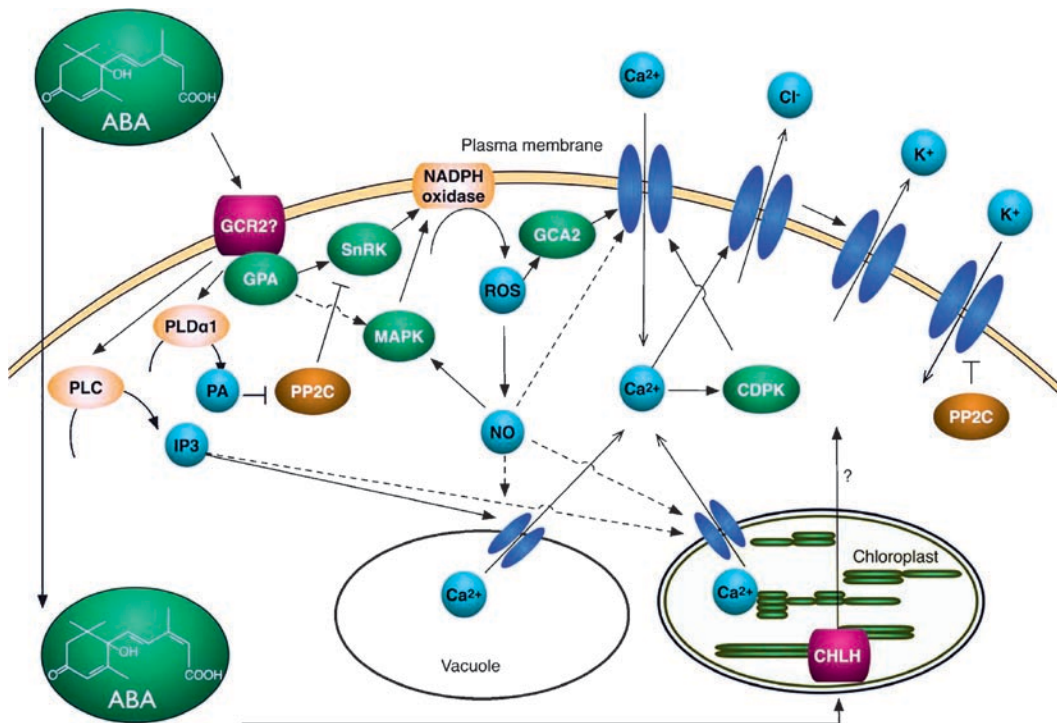

Fig. 1. Schematic illustration of ABA signaling in stomatal closure. Arrows indicate positive or negative interactions between the factors. Dashed arrows indicate possible regulation [See Color Plate 2, Fig. 3].

### B MAPK Signaling Components

Several lines of evidence from biochemical and genetic studies support the involvement of reversible protein phosphorylation in the regulation of plant stress responses to various environmental stimuli. Application of ABA induces activation of mitogen-activated protein kinases (MAPKs) within a few minutes in barley aleurone protoplasts (Knetsch et al. 1996), and of calcium-dependent protein kinases (CDPKs) in wheat (Li et al. 2008a). In *Arabidopsis*, 20 MAPKs have been identified and classified into four major groups (Group et al. 2002; Colcombet and Hirt 2008). ABA activates AtMPK1, AtMPK2 (Ortiz-Masia et al. 2007; Hwa and Yang 2008) and AtMPK3 (Lu et al. 2002). Overexpression of *AtMPK3* increases ABA sensitivity and inhibition of MAPK signaling by application of a MAPK kinase (MAPKK)-specific inhibitor (PD98059) decreases ABA sensitivity in the postgermination stage of seedling growth (Lu et al. 2002). Consistent with these results, plants overexpressing *AtMKK3* exhibit an enhanced tolerance to salt and are more sensitive to ABA, suggesting that the ABA signal is transmitted to the transcriptional apparatus through MAPK signaling (Hwa and Yang 2008). ABA is known to induce antioxidant defense through ROS production (Guan et al. 2000), and MAPK signaling acts downstream of ROS in maize (Zhang et al. 2006). In *Arabidopsis*, oxidative stress activates AtMPK3 and AtMPK6, and an *mpk6* mutant blocks, whereas *AtMPK6*-overexpressing transgenics enhance, the ABA-dependent expression of CAT1 and H<sub>2</sub>O<sub>2</sub> production in an AtMKK1-dependent manner (Kovtun et al. 2000; Moon et al. 2003; Xing et al. 2008). The *mkk1* mutant reduces both the sensitivity to ABA during germination and the drought tolerance of seedlings, whereas an *AtMKK1* overexpression line shows the opposite responses (Xing et al. 2008). Upon oxidative stress, catalase plays an important role in scavenging H<sub>2</sub>O<sub>2</sub> (Mittler et al. 2004). In contrast to the case in maize, the MAPK signaling acts upstream of H<sub>2</sub>O<sub>2</sub> production in *Arabidopsis* (Ichimura et al. 2000; Xing et al. 2007, 2008). The Ku heterodimer has been found in many eukaryotes and is involved in many cellular metabolic processes such as transcriptional regulation, cell cycle regulation and DNA repair (Downs and Jackson 2004). Liu et al. (2008a, b) reported that down regulation of *Arabidopsis* *Ku* genes by ABA

involves p38-MAPK and AtMPK6 upstream of the transcription factors ABI3, ABI5 and ATHB6, and downstream of Ca<sup>2+</sup> and PLD $\alpha$ . Another link to Ca<sup>2+</sup> is the finding that a negative regulator of MAPKs, MAPK phosphatase 1 (AtMKP1), is activated by calmodulin in a Ca<sup>2+</sup>-dependent manner in *Arabidopsis* (Lee et al. 2008a).

### C Sucrose Non-fermenting-Related Protein Kinase 2 (*SnRK2*) Proteins

Involvement of SnRK2 proteins in ABA signaling was first reported in wheat. PKABA1 was identified as an ABA- and dehydration-induced transcript (Anderberg and Walker-Simmons 1992). *AAPK* was cloned from *Vicia faba* as a guard cell-specific ABA-activated serine-threonine protein kinase (Li and Assmann 1996; Li et al. 2000). In-gel kinase assays also revealed the presence of 42- and 44-kDa protein kinases that were rapidly activated by ABA but showed different substrate specificities from MAPKs in *Arabidopsis* cultured T87 cells. Subsequent analyses revealed that p44 is encoded by *SnRK2.6* (Yoshida et al. 2002). *Arabidopsis* mutants of *OPEN STOMATA1* (*ost1*) have defects in stomatal closure upon drought stress. Positional cloning of *OST1* revealed it is identical to *SnRK2.6* (Mustilli et al. 2002). The *ost1/snrk2.6* mutation affects stomatal closure in an ABA-dependent- and ABA-independent manner, and the ABA-dependent pathway seems to be regulated by direct interaction of a protein phosphatase ABI1 with SnRK2.6 (Mustilli et al. 2002; Yoshida et al. 2006 b). On the other hand, seed dormancy and germination were not affected in *ost1/snrk2.6* mutants (Allen et al. 1999; Mustilli et al. 2002; Yoshida et al. 2002). *SnRK2.6*-like genes are plant-specific *SnRKs.6* and the *Arabidopsis* genome has ten *SnRK2.6* genes. Except *SnRK2.6*, all *SnRK2.6* genes are activated by osmostresses, suggesting the importance of this SnRK kinase group in the stress adaptation of plants. Among other *SnRK2* genes, three (*SnRK2.2*, *SnRK2.3* and *SnRK2.6*) are highly homologous and also strongly activated by ABA (Boudsocq and Lauriere 2005). A *snrk2.2 snrk2.3* double mutant, but not *snrk2.2* or *snrk2.3* single mutants, showed strong ABA insensitivity in seed germination and root growth inhibition, but little effect on stomatal control (Fujii et al. 2007), suggesting

that SnRK2.2 and SnRK2.3 have redundant functions but distinct from SnRK2.6 in the regulation of ABA signaling.

The ABA responsive element (ABRE) found in promoter of ABA-inducible genes is recognized by basic leucine zipper (bZIP/ABF) type transcription factors. Several studies have shown that ABFs require activation by ABA through phosphorylation (Uno et al. 2000; Lopez-Molina et al. 2001; Furihata et al. 2006), and SnRK2.2 and SnRK2.3 are the key kinases mediating this post-translational modification (Furihata et al. 2006; Fujii et al. 2007). ABI5/ABF-binding proteins (ABFs) are highly conserved novel plant-specific proteins that function to antagonize ABF activities in seedlings, possibly by proteolysis (Lopez-Molina et al. 2003; Garcia et al. 2008; Ohnishi et al. 2008). The wheat SnRK2 (PKABA1) phosphorylates ABRE-binding bZIP proteins (Johnson et al. 2002), and a rice SnRK2 (SAPK10) phosphorylates a rice ABF (TRAB1) (Kobayashi et al. 2005), indicating a conserved ABA signaling pathway through phosphorylation of ABFs by SnRK2s in angiosperms. Wheat TaABF1 also functions downstream of PKABA1 in ABA-suppression of GA-induced gene expression (Johnson et al. 2008). Over-expression of the rice *SnRK2* homologue *SAPK4* under control of the CaMV-35S promoter results in improved germination, growth and development under salt stress, both in seedlings and mature plants (Diedhiou et al. 2008).

#### D Phosphatases

Involvement of reversible protein phosphorylation in ABA signaling has been long known from molecular genetics, and more recently from reverse genetics approaches. The first identified molecular components of ABA were the orthologous transcription factors VIVIPAROUS1/ABI3, and the second were *ABI1* and *ABI2* that encode homologous type 2C (Mg<sup>++</sup> dependent) protein phosphatases (PP2Cs) (Leung et al. 1994, 1997; Meyer et al. 1994). The *abi1-1* and *abi2-1* mutations (Koornneef et al. 1984) occur in the highly conserved catalytic domains that cause substitution of the same amino acid (Gly to Asp) and cause pleiotropic effects on most physiological processes mediated by ABA. The *ABI1-1* and *ABI2-1* proteins act as strong negative regulators

of ABA signaling in various processes, suggesting that *ABI1* and *ABI2* are located upstream in ABA-signaling pathways. Nuclear localization is an essential aspect of *ABI1* function; disruption of the NLS in *abi1-1* rescued ABA-controlled gene transcription and attenuated *abi1-1* insensitivity to the hormone during seed germination, root growth and stomatal movement (Moes et al. 2008). Because the *abi1-1* dominant mutation results in a preferential accumulation of the protein in the nucleus, it is now becoming clear that it is a hypermorphic allele and *ABI1* reprograms sensitivity towards ABA in the nucleus.

The *Arabidopsis* genome has 76 genes encoding PP2Cs, seven of which are closely related to *ABI1/ABI2* based on sequence homology (Schweighofer et al. 2004). Genetic analysis of germination processes in *Arabidopsis* resulted in map-based cloning of *ABA HYPERSENSITIVE TO GERMINATION (AHG)* genes which encode PP2Cs in the *ABI1* clade (Gosti et al. 1999; Tahtiharju and Palva 2001; Saez et al. 2004, 2006; Kuhn et al. 2006; Yoshida et al. 2006a, b; Nishimura et al. 2007). Intragenic revertants of *abi1-1* and antisense repression of, or T-DNA insertions in, these homologs lead to hypersensitive ABA phenotypes, confirming the role of *ABI1*-related PP2Cs in the negative regulation of ABA signaling (Gosti et al. 1999; Tahtiharju and Palva 2001; Saez et al. 2004; Kuhn et al. 2006; Saez et al. 2006; Yoshida et al. 2006a; Nishimura et al. 2007). These studies and other genomic approaches, such as overexpression of MYB TFs that confer stress tolerance (Jung et al. 2008) or high-throughput transient expression assays demonstrate the distinct but partially redundant functions of *ABI1*-related PP2Cs in the regulation of ABA signaling. A PP2C from beech (*FsPP2C2*), whose expression is induced by ABA, was shown to act as a positive regulator of ABA signaling when expressed in *Arabidopsis* (Lorenzo et al. 2002; Reyes et al. 2006). Similarly, Jia et al. (2009) identified *AP2C1* and *AP2C2* as positive candidate effectors of ABA sensitivity in maize protoplasts, suggesting that PP2Cs do not act solely as negative regulators of stress responses. In this context the results of de Torres-Zabala et al. (2007) are interesting. They demonstrated that virulence of the plant pathogen *Pseudomonas syringae* is dependent on modulating host ABA- and stress response



pathways through ABI1-Like PP2C expression and increased ABA biosynthesis. Their results raise questions about how hypothetical negative ABA regulators in the ABI1 clade can work. The existence of positive PP2C effectors (Reyes et al. 2006; Jia et al. 2009) provide a compelling molecular mechanism (induced positive effectors of ABA) for increased ABA sensitivities required for pathogen infection.

Since the target proteins of the PP2Cs are likely the substrates of kinases involved in ABA signaling, many studies have investigated the interacting molecules of ABI1-related PP2Cs. So far, the substrates of the PP2Cs are unknown, however these studies suggest the variety of processes with which the PP2Cs may be associated. ABI1 has been shown to interact with PA, an important second messenger in ABA-induced stomatal closure. PA decreases ABI1 phosphatase activity and also promotes the translocation of ABI1 to the plasma membrane (Zhang et al. 2004), suggesting that sequestering of ABI1 to the plasma membrane would inactivate it. This model is consistent with the recent finding of ABA-induced nuclear localization of ABI1 is required for ABA sensitivity (Moes et al. 2008). Arg-73 in the N-terminal region of ABI1 is required for ABI1 binding to PA. Since the N-terminal regions of the conserved catalytic domain in ABI-related PP2Cs are variable, it is possible the N-terminal regions confer specificity. *ABI1* but not *ABI2* interacts with SnRK2.6/OST1 through the conserved C-terminal region of ABA-activated SnRK2s and this interaction is affected by the *abi1-1* mutation (Yoshida et al. 2006a, b). Other studies also found interactions between *ABI1/ABI2* and *SnRK3s*, another plant-specific group of SnRKs. *Arabidopsis SALT OVERLY SENSITIVE2 (SOS2)* encodes SnRK3.11/CIPK24 responsible for sodium and potassium ion homeostasis and salt tolerance. *SOS3* calcium-binding protein (CBL4) activates *SOS2*. *ABI2* and to a lesser extent *ABI1* bind directly to *SOS2*, and the *abi2-1* mutation disrupts the interaction (Ohta et al. 2003). *ABI2* also interacts physically with GLUTATHIONE PEROXIDASE3 (GPX3) and *atgpx3* mutants are wilted, have elevated peroxide in guard cells and disrupt ABA activation of calcium channels and the expression of ABA- and stress-responsive genes (Miao et al. 2006). Another ABI1-related PP2C, AtPP2CA was shown to interact with an *Arabidopsis*

inward-rectifying K<sup>+</sup> channel AKT2/3, and the interaction controlled the channel activity through the phosphatase activity of AtPP2CA, suggesting a role for AtPP2CA in the regulation of K<sup>+</sup> transport and membrane polarization during stress conditions (Vranova et al. 2001; Cherel et al. 2002).

Recent studies have highlighted the significant role of another protein phosphatase group, PP2A. Loss-of-function and gain-of-function analyses of a PP2A catalytic subunit gene (*PP2Ac-2*) in *Arabidopsis* demonstrated the negative role of this phosphatase in ABA signaling (Pernas et al. 2007). ABA sensitivity is partially restored in the *abi1-1/pp2ac-2* double mutant, suggesting that both PPs act in the same ABA signaling pathway. *ROOTS CURL IN NPA1 (RCN1)* encodes a scaffold subunit of PP2A (PP2A-A $\alpha$ ) and the *rcn1* mutant has defects in auxin transport (Deruere et al. 1999), however disruption of *RCN1* also confers ABA insensitivity (Kwak et al. 2002). An A subunit of PP2A is ubiquitinated by *Arabidopsis* E3 ubiquitin ligase AtCHIP, and overexpression of *AtCHIP* increases the phosphatase activity of PP2A, leading to increased ABA sensitivity (Luo et al. 2006).

### E Protein Modification

Ubiquitination is a regulatory mechanism of targeted proteolysis necessary for all aspects of development and survival of eukaryotes. Recent genomic and genetic analysis in *Arabidopsis* suggests that ubiquitination and the related sumoylation pathways play important roles in plant responses to ABA (Lois et al. 2003; Miura et al. 2007; Stone and Callis 2007; Zhang and Xie 2007). Many components of the ubiquitination pathway, such as ubiquitin-conjugating enzyme E2, ubiquitin ligase E3, zinc-finger and F-box proteins and components of the proteasome, have been identified or predicted to be essential in ABA metabolism and/or stress signaling (Lai et al. 2004; Cho et al. 2008; Huang et al. 2008b; Kanneganti and Gupta 2008; van den Burg et al. 2008; Xu et al. 2008). AtPUB9 (Plant U-Box9 E3 ligase) is redistributed to the plasma membrane of tobacco BY-2 cells after treatment with ABA or when coexpressed with the active kinase domain of self-incompatibility-like receptor kinase ARK1. T-DNA insertion mutants for *ARK1* and *AtPUB9* lines are altered



in their ABA sensitivity during germination and act at or upstream of *ABI3*, indicating potential involvement of these proteins in ABA responses (Samuel et al. 2008).

Recent biochemical and genetic analyses have revealed that secretory peptides like CLAVATA3 and TRACHEARY ELEMENT DIFFERENTIATION INHIBITORY FACTOR (TDIF), which regulate meristem formation and vascular development respectively, are also responsible for various events including wound response, cell division control, self-incompatibility and host-parasite interactions (Sawa et al. 2006). A genome-wide screen of *Arabidopsis* T-DNA insertion lines for 57 receptor-like protein (RLP) genes identified TOO MANY MOUTHS (TMM) and AtRLP41 (At3g25010) that mediate ABA sensitivity to chlorosis in leaves (Wang et al. 2008a). A plasma membrane leucine-rich-repeat receptor kinase (RPK1) has also been found to act early in ABA signaling (Osakabe et al. 2005) and might interact with these RLPs, analogous to RLK CLAVATA1 and RLP CLAVATA2.

*PLURIPETALA (PLP)* encodes the  $\alpha$ -subunit shared between protein farnesyltransferase and protein geranylgeranyltransferase-1 and was genetically selected based on dramatically larger meristems and increased floral organ number (Running et al. 2004). Mutants of *PLP* have altered ABA responses, slower growth rates, and synergistic interactions with the *clavata3* mutant, and are epistatic to mutations in the ENHANCED RESPONSE TO ABA (ERA1)  $\beta$ -subunit of farnesyltransferase. Downregulation of either the  $\alpha$ - or  $\beta$ -subunit of farnesyltransferase enhances plant responses to ABA and drought tolerance (Johnson et al. 2005; Wang et al. 2005). Mutant *era1* plants display enhanced susceptibility to virulent bacterial and oomycete pathogens, implying a role for farnesylation in basal defense (Goritschnig et al. 2008). Isoprenyl cysteine methyltransferase (ICMT) is involved in prenylation and RNAi knockdown mutants of *Arabidopsis AtICMTA* have a similar phenotype as ERA1 (Brachardori et al. 2008). The *plp* mutant suggests a link between prenylation, ABA responses and peptide signaling. In this context it is also interesting to note that a putative secretory peptidase, VIVIPAROUS8, affects ABA signaling during embryo and endosperm development upstream of B3 domain- and LEC1 transcription factors (Suzuki

et al. 2008a). Another recently discovered pathway interacting with ABA is N-acylethanolamines, bioactive acylamide metabolites found in plants and animals whose functions are poorly understood (Teaster et al. 2007).

## V Regulation of Abiotic Stresses at the Level of Gene Expression

### A *Cis-Acting Elements for ABA-dependent Gene Expression*

Many genes induced by osmotic stresses such as drought, salinity and cold are also ABA-responsive (Seki et al. 2002a, b). The majority of these genes are classified into two groups: one functioning in protection of cells from stresses, such as LATE EMBRYOGENESIS ABUNDANT (LEA) proteins, enzymes for osmolyte biosynthesis and detoxification enzymes; the other functioning in signal transduction pathways such as enzyme-generated second messengers, phosphorylation, chromatin remodeling and transcription factors. Early work in ABA signaling and gene regulation was focused on the identification of *cis*-acting elements in promoters of these dehydration-responsive genes (Marcotte et al. 1988, 1989; Guiltinan et al. 1990). These studies identified *cis*-elements required for ABA-induction, including the ABA Responsive Element (ABRE; PyACGTGGC), the MYB-responsive element TGGTTAG, and the MYC-responsive element CACATG (Finkelstein et al. 2002). Among them, ABRE is considered as a major *cis*-element in ABA-induced gene expression. However, a single ABRE is not sufficient for ABA response, and either an additional ABRE (Marcotte et al. 1989) or coupling elements (CE) are required (Shen and Ho 1995).

Recently, a novel motif overrepresented in genes up-regulated within 5 min of wounding was identified (Rapid Stress Response Element, RSRE) (Walley et al. 2007). Transgenic plants with multimerized RSREs have a rapid response to biotic and abiotic stresses *in vivo*, thereby establishing the functional involvement of this motif in primary transcriptional stress responses. Forward genetic screens of mutagenized transgenic ProRSRE:reporter *Arabidopsis* may facilitate identification of the signaling components of

mechanical stress including the presumed trigger for ABA responses, namely turgor changes.

ABI5 and related bZIP transcription factors (AREBs/ABFs) bind to ACGT-containing ABREs (Uno et al. 2000) and Ethylene Response Factor/APETELA2 (ERF/AP2)-type transcription factor ABI4 binds to one of the CEs (CE1) (Niu et al. 2002). ABI4 was originally isolated as an ABA-insensitive mutant but has been demonstrated to act also in sugar and retrograde signaling from chloroplast to nucleus (Rook et al. 2006a, b; Koussevitzky et al. 2007; Ramon et al. 2007). The recent finding that ABI4 overexpression cannot rescue the glucose-insensitive phenotype of *aba2*, and that *abi3*, *era1* and *abi2* mutants are also glucose insensitive, extends the cross-talk network between sugar and ABA (Dekkers et al. 2008). An alternative ABA-dependent pathway exists for the drought-inducible *RD22* gene, which can be activated by transcription factors AtMYB2 and AtMYC2 (Abe et al. 1997). Overexpression of AtMYB2 and AtMYC2 results in ABA hypersensitivity and enhanced osmotic stress tolerance (Abe et al. 2003), but MYC2 has also been implicated in biotic stress responses and light signaling (Anderson et al. 2004; Lorenzo et al. 2004; Yadav et al. 2005; Dombrecht et al. 2007; Bu et al. 2008).

Recent studies have shown that some ABA-inducible members of a plant-specific transcription factor family that have a DNA binding NAC domain (NO APICAL MERISTEM, ATAF, and CUP-SHAPED COTYLEDONS) are also responsible for ABA signal transduction and osmotic stress responses. An *Arabidopsis* drought-inducible gene *RD26* encodes a NAC protein that recognizes a sequence ACACGCATGT responsible for ABA- and osmotic stress-induced expression of *ERD1* (Fujita et al. 2004). Overexpression of ANACs (ABA-responsive NACs) confers increased ABA sensitivity and osmotic stress tolerance in *Arabidopsis* and rice (Fujita et al. 2004; He et al. 2005; Hu et al. 2006, 2008). However, sets of genes up- or down-regulated in these overexpressing plants were different from each other, suggesting that different stress-responsive ANAC transcription factors may activate the different set of target genes to confer various stress resistances. For example, a salt-inducible membrane-bound NAC (NTL8) down-regulates GA biosynthesis to confer salt tolerance by inhibiting

*Arabidopsis* seed germination independent of ABA (Kim et al. 2008b).

Microarray analyses have revealed the presence of genes that are controlled by abiotic stresses but not ABA, indicating the presence of ABA-dependent and ABA-independent pathways in the regulation of dehydration-responsive genes (Seki et al. 2002a, b, 2004; Huang et al. 2008a; Matsui et al. 2008). The drought-responsive element (DRE); also referred as to C-repeat element (CRT), mediates both cold- and osmotic stress-inducible ABA-independent gene expression (Shinozaki and Yamaguchi-Shinozaki 2000). The DRE is recognized by two families of plant-specific ERF/AP2s: CBF (C-repeat binding factors, also known as dehydration-responsive element-binding protein 1s or DREB1s) and DREB2s (Shinozaki and Yamaguchi-Shinozaki 2000). The CBF family consists of cold-inducible CBF1/DREB1B, CBF2/DREB1C and CBF3/DREB1A (Stockinger et al. 1997; Liu et al. 1998), and non-cold-inducible CBF4/DREB1D, DREB1E and DREB1F (Stockinger et al. 1997; Haake et al. 2002). Over-expression of CBF/DREB1 family members can confer enhanced freezing tolerance of plants, suggesting that the transcription factors are responsible for cold-specific responses (Chinnusamy et al. 2007). The DREB2 family consists of cognates DREB2A and DREB2B (Liu et al. 1998), but >50 DREB-like homologous transcription factors are found in *Arabidopsis*. Expression of *DREB2* genes is induced by drought and salinity but not cold, suggesting that DREB2 family are involved in drought/salinity stress, a notion supported by transgenic studies with tobacco (Kobayashi et al. 2008a). These CBF and DREB2 transcription factors have been considered to act in ABA-independent manner, however studies have demonstrated that transcription of *Arabidopsis* CBF1-4 is also inducible by ABA (Knight et al. 2004). Two *CBF/DREB1* like genes isolated from grape are also responsive to cold, drought and ABA (Xiao et al. 2006). The finding that TINY, an ERF/AP2-like transcription factor, is induced by drought, cold, ethylene, and methyl jasmonate and binds to both DREs and the ethylene responsive elements (EREs) with similar affinity to transactivate the expression of reporter genes suggests it may function in cross-talk between abiotic- and biotic-stress responsive gene expression (Sun et al. 2008).

### Box 3.1 Systems Approaches to Stress Tolerance

The development of genomics and microarray technologies enables researchers to mine datasets for metabolic or hierarchical “clusters” characteristic of physiological or pathological states and to screen for subtle changes in response to effector treatments. New tools are creating exciting opportunities to address many of the important unanswered questions in plant science in a way that was not possible previously. Genomic signatures can be used to classify the plant abiotic stress phenotype according to the architecture of the transcriptome, and then linked with gene coexpression network analysis to determine the underlying genes governing the phenotypic response (Weston et al. 2008; Khandelwal et al. 2008). For example, hierarchical clustering techniques have been used to compare whole-genome expression levels in *Arabidopsis* PP2Cs (Jia et al. 2009) and *athk1* osmosensor mutants (Wohlbach et al. 2008). A molecular and metabolic systems approach has been applied to ABA regulatory and marker genes involved in cold tolerance (Benedict et al. 2006).

The application of proteomics and protein microarrays will be critical to future understanding of physiological processes not accounted for at the genomic level (Jorin et al. 2007). For example, combining protein microarray technology with fluorescent sensors of phosphorylation status allows for screening of protein kinase and phosphatase inhibitors and the identification of physiologically relevant substrates for protein kinases and phosphatases. Recently a peptide array was screened to define the phosphorylation preferences of four kinases from *Arabidopsis* and a conserved motif identified in the stress-related dehydrin protein family targeted by SnRK2.10 (Vlad et al. 2008).

Another example of future directions is analysis of salt- and ABA-regulated proteomes (Chitteti and Peng 2007; He and Li 2008). Approximately 205 proteins extracted from nuclei of drought-stressed chick pea were found by 2D-SDS PAGE to be differentially expressed; 147 of these were identified by mass spectrometry and predicted to function in gene transcription, replication, molecular chaperones, cell signaling and chromatin remodeling (Pandey et al. 2008). 2D-PAGE and mass spectrometry allowed the identification of 85 cold-stress modulated proteins in rice, including well known (e.g., RubiscoL) and novel cold-responsive proteins implicated in a variety of pathways. An “interactome” of proteins associated with abiotic stress response and development in wheat was generated using a yeast two-hybrid system (Tardif et al. 2007).

## VI Responses to Temperature Stresses

### A Cold Stress Responses

Most temperate plants acquire freezing tolerance after exposure to low non-freezing temperatures (below 10°C), a process called cold acclimation. Numerous physiological and molecular changes occur during cold acclimation, leading to protection of cells from irreversible damage due to mechanical forces generated by growth of ice crystals, as well as cellular dehydration and increased concentrations of intracellular salts. Compared to the established role of ABA signaling in drought and salinity, studies on the physiological role of ABA in freezing stress tolerance are conflicting. Application of exogenous ABA

to cell suspension cultures of hardy plants such as rye and brome grass dramatically increases freezing tolerance comparable to cold acclimation, but enhanced freezing tolerance is not observed in non-hardy plants species (Chen and Gusta 1983). On the other hand, application of exogenous ABA to whole plants via roots, stem cuttings or spraying results in significant but limited increases in freezing tolerance compared to cold acclimation (Irving and Lanphear 1968; Gusta et al. 1982; Lalk and Dorffling 1985; Churchill et al. 1998). Recent studies on molecular mechanisms of low temperature response have been carried out in *Arabidopsis*, which has a limited capacity for cold acclimation. In this model plant, ABA accumulation upon low temperature treatment occurs transiently and markedly less than during water stress

(Lang et al. 1994), thus a major pathway for cold response is considered to be ABA-independent and mediated through CBF/DREB1 transcription factors. However, some ABA-related mutants such as *abi1* (Lang et al. 1994), *los5* (*low osmotic response5*)/*aba3* (*ABA deficient3*) (Xiong et al. 2001), and *los6/aba1* (Lang et al. 1994; Xiong et al. 2002) appear to be impaired in their ability to cold acclimate. Antisense repression of ABI1-like PP2C (*AtPP2CA*) increases ABA sensitivity and accelerates cold acclimation of transgenic *Arabidopsis* plants (Tahtiharju and Palva 2001). These findings suggest that ABA signaling also plays a role in cold acclimation in *Arabidopsis*. Recently, the wheat ABA-hypersensitive mutant ABA27 has been reported to show enhanced freezing tolerance before or after low temperature treatment and to accumulate ABA-responsive transcripts in response to cold (Kobayashi et al. 2008c). Cereal *lip19* genes encode bZIP-type transcription factors that belong to a different clade from ABI5/AREB/ABF and their expression is strongly induced by low temperatures. Ectopic expression of *Wlip19* in tobacco plants induces expression of *COR* (*cold-responsive*)/*LEA* genes and increases freezing tolerance and ABA sensitivity (Kobayashi et al. 2008b). These data suggest that ABA sensitivity plays a positive role in the regulation of freezing tolerance in wheat. However, dominant wheat mutant EH47-1 shows reduced ABA sensitivity and higher freezing tolerance despite higher basal expression of ABA-responsive *COR* genes and no changes of *COR* expression during cold acclimation. The authors interpret these results to suggest that the basal level of freezing tolerance is under control of ABA sensitivity (Kobayashi et al. 2006). When each of three bZIP transcription factors from soybean (GmbZIP44, 62 and 78) were ectopically expressed in *Arabidopsis*, the transgenic plants showed decreased ABA sensitivity but increased freezing tolerance correlated with enhanced expression of *ABI1*, *ABI2* and *COR* genes (Liao et al. 2008).

The interaction between freezing tolerance and ABA in plants other than angiosperms is poorly understood. Several studies of the cold acclimation capacity of green algae have been reported. Unicellular green algae, such as *Chlamydomonas* spp. and *Cladophora sauteri*, cannot cold acclimate (Terumoto 1959; Leeson et al. 1984). In contrast, *Chlorella* spp. increase freezing tolerance

after cold treatment, although *Chlorella* is not closely related to land plants (Hatano et al. 1976). Recently, cold acclimation of *Klebsormidium flaccidum*, a charophycean green alga and a sister group of land plants, has been reported. Although low temperature treatment increases the freezing tolerance in a manner comparable to that of *Arabidopsis*, ABA treatment does not (Nagao et al. 2008), suggesting that ABA does not play a role in cold acclimation of *K. flaccidum*. The model basal plant *Physcomitrella patens* has the capacity to increase freezing tolerance during low temperature treatment. Application of exogenous ABA, even as low as 0.1  $\mu\text{M}$ , for 24 h is effective to develop freezing tolerance of protonemata comparable to low temperature treatment (0°C) for a week. However, ABA accumulation does not change significantly during low temperature treatment (Minami et al. 2003, 2005).

These studies clearly demonstrate that land plants are capable of increasing freezing tolerance by cold acclimation as well as by ABA acclimation. Because ABA accumulation is not always observed with low temperatures, we need to consider that these experiments were carried out under controlled environments, an artificial situation compared to the natural environment where temperatures decrease more gradually and are accompanied by changing photoperiods (Gusta et al. 2005). Recently, a novel plant-specific protein ESKIMO1 (ESK1) has been cloned that affects freezing tolerance. In *esk1* mutants, very few genes that are under the control of CBFs or their upstream regulator ICE1 are up-regulated. Instead, the genes up-regulated in *esk1* show extensive overlap with genes reported to be induced by salt and osmotic stresses as well as by ABA, including PP2Cs (Xin and Browse 1998; Xin et al. 2007). ESK1 is a negative regulator of a yet-unknown cold acclimation process where ESK1 levels do not change during cold acclimation. These results demonstrate a CBF/DREB1-independent pathway for cold acclimation in *Arabidopsis*. Forward genetic screens for drought-stress modulation of lateral root formation and non-CBF cold-inducible gene expression also identified ABA response mutants that should provide insights into drought- and cold tolerance machineries (Medina et al. 2005; Xiong et al. 2006). An exciting development is the recent report that expression in plants of bacterial



Cold-Stress-inducible Proteins (CSPs) that function as RNA chaperones (for which there are homologs in plants) confers improved cold, heat and water-deficit tolerance in multiple plant species and without costs to productivity under well-watered conditions (Castiglioni et al. 2008).

### B Heat Stress Responses

ABA is also known to be involved in heat stress response (Penfield 2008). ABA and gibberellins (GAs) act antagonistically to regulate seed germination, with ABA inhibiting it and GA promoting it. Seed responsiveness to temperatures plays an ecologically important role in the detection of the appropriate seasonal timing for germination. Suppression of germination at supraoptimal high temperatures is called thermoinhibition (Reynolds and Thompson 1971) and involvement of ABA and GA has been implicated in this process (Yoshioka et al. 1998; Gonai et al. 2004). *Arabidopsis* germinates completely at 22°C, whereas more than 90% of seed germination is suppressed by incubation at 34°C. The ABA-deficient mutant *aba1-1* and ABA-insensitive mutant *abi1-1* are highly tolerant to thermoinhibition, suggesting that ABA also plays an important role (Tamura et al. 2006). Toh et al. (2008) showed that high temperatures activate the ABA biosynthesis genes *ABA1*, *NCED2*, *NCED5* and *NCED9* and also enhance expression of a GA negative-regulator gene (*SPY*) which suppresses expression of GA biosynthesis genes. This scheme is quite similar to that of dormant seeds imbibed at room temperature. A common genetic mechanism may regulate the inhibition of germination in dormant seeds and after-ripened seeds exposed to high temperature. Transition of the active growth phase to the resting stage observed in many herbaceous species in Mediterranean habitats occurs after induction of summer dormancy (Ofir and Kerem 1982). This transition involves major developmental changes including production of bulbs, corms, and tuberous roots, formation of dormant buds and arrest of meristematic activity followed by senescence of above-ground parts. The summer dormancy of *Poa bulbosa* is induced by long days and water deficits. Exogenous ABA can also induce summer dormancy, suggesting that increased levels of endogenous ABA are likely involved in these pathways (Ofir and Kigel 1998, 2007).

Exogenous ABA, heavy metals or dehydration stress induce heat tolerance in maize seedlings (Bonham-Smith et al. 1987). Overexpression of the seed-specific HSF9 transcription factor from sunflower is sufficient to confer tolerance to severe dehydration to vegetative tissues of transgenic tobacco (Prieto-Dapena et al. 2008). ABA also induces heat tolerance of cell-suspension culture prepared from bromegrass (*Bromus inermis*), suggesting that ABA confers heat tolerance at the cellular level (Robertson et al. 1994). It is noteworthy that ABA application also confers freezing tolerance of these cells at nonacclimating temperatures (Chen and Gusta 1983), suggesting that ABA confers simultaneously more than one temperature stress tolerance. Transient accumulation of endogenous ABA was observed after heat treatment in pea (Liu et al. 2006). Larkindale et al. (2005) investigated 45 *Arabidopsis* mutants for heat stress tolerance and found that ABA signaling mutants *abi1-1* and *abi2-1* showed the strongest defects in acquired thermotolerance, but the accumulation of heat shock proteins (HSPs) was not affected in these mutants, suggesting that ABA function in heat stress response is different from HSP-pathway (Kotak et al. 2007). However, a genetic screen with an *Arabidopsis* cDNA expression library for ABA insensitivity during germination identified HSP17.6A as a negative regulator of ABA response (Papdi et al. 2008). A dominant mutant that shows high tolerance to hot and dry air (*harmattan tolerant 1*, *hat1*) is also ABA hypersensitive (Yan et al. 2006a). Brassinolide treatment can enhance the thermotolerance of *Brassica napus* leaves by elevating ABA levels (Kurepin et al. 2008).

ABA appears to function in preventing denaturation and coagulation of cellular proteins or membranes under heat stress condition by induction of heat-stable polypeptides in combination with sucrose (Robertson et al. 1994), and also to protect cells from heat stress-induced oxidative stress (Larkindale and Knight 2002; Larkindale and Huang 2004). Recently Zimmerli et al. (2008) reported that  $\beta$ -aminobutyric acid (BABA)-induced thermotolerance of *Arabidopsis* requires HSP101, suggesting that ABA might also function in an HSP-dependent pathway. Heat tolerance also involves calcium,  $IP_3$  and  $H_2O_2$  that are known second messengers of ABA signaling,



as well as other plant hormones salicylic acid (SA) and ethylene (Kotak et al. 2007). A highly conserved transcriptional coactivator, MBF1c (multi-protein bridging factor 1c), is a key regulator of thermotolerance in *Arabidopsis*, possibly by interaction with TPS5 (trehalose phosphate synthase5), which is heat-inducible and *tps5* mutants are thermosensitive. Interactions between SA, ethylene and ABA signaling in heat stress response are unclear but this is not different than other hormone cross-talk in stress responses.

## VII Cross-Talk Between Abiotic and Biotic Stress Responses

A large body of evidence indicates cross talk between abiotic and biotic stress responses is mediated by stress hormones. SA, jasmonic acid (JA) and ethylene form a complex network that plays major roles in disease resistance (Thomma et al. 2001; Lopez et al. 2008). ABA itself mainly plays a negative role in disease resistance, probably by an antagonistic effect on SA/JA/ethylene-mediated defense signaling (Mauch-Mani and Mauch 2005; Korolev et al. 2008; Yasuda et al. 2008). Effectors/elicitors secreted by *Pseudomonas syringae* pv. *tomato* activate ABA biosynthesis and ABA signaling, which leads to the suppression of defense responses (de Torres-Zabala et al. 2007). However, several studies have reported the positive effect of ABA on disease resistance. Plant stomata serve as passive port of bacterial entry during infection. Pathogen-associated molecular patterns (PAMPs) of *P. syringae* pv. *tomato* induce stomatal closure, which requires the flagellin receptor FLS2, ABA biosynthesis, NO production, and OST1, suggesting the integration of abiotic and biotic signaling in stomatal regulation (Melotto et al. 2006). Expression of the type III effector HopAM1/AvrPpiB makes transgenic *Arabidopsis* hypersensitive to ABA for stomatal closure and germination arrest (Goel et al. 2008). A link between thermotolerance, ABA and biotic stress has been uncovered with the non-protein amino acid BABA. Treatment of plants with BABA results in resistance to biotic as well as abiotic stresses such as drought, high salt (Conrath et al. 2002), and heat (Zimmerli et al. 2008). A mutant impaired in BABA-induced sterility (*ibs3*) is affected in the regulation of the

*ABAI* gene and BABA-induced pathogen and salt resistance (Ton et al. 2005). BABA prevents pathogen-induced suppression of ABA accumulation and sensitizes the tissue to ABA (Flors et al. 2008). ABA-insensitive and biosynthetic mutants show defects in BABA-acquired thermo- and salt tolerance (Jakab et al. 2005; Larkindale et al. 2005), suggesting that the BABA-induced resistance (BABA-IR) requires ABA biosynthesis and ABA signaling (Ton and Mauch-Mani 2004; Ton et al. 2005). Further evidence of a link between ABA-mediated abiotic and biotic signaling was also shown by isolation of an activation-tagged mutant of *adr* (*activated disease resistance1*) that exhibits both broad-spectrum disease resistance and drought tolerance. *ADR1* encodes a CC (coiled-coil domain)-NBS (nucleotide-binding site)-LRR (leucine-rich repeat) protein with putative Ser/Thr kinase domains. A large proportion of the genes up-regulated in *adr1* overlapped with genes for dehydration stress responses. The drought tolerance requires SA, *EDS* (*ENHANCED DISEASE SUSCEPTIBILITY1*), and *ABII*. Interestingly, *adr1* plants are more sensitive to heat and salt stresses, suggesting an antagonism between abiotic stresses and biotic stresses (Chini et al. 2004).

HrpN, a protein elicitor produced by the plant pathogenic bacterium *Erwinia amylovora*, stimulates growth and resistance to insect and bacterial infection when applied to *Arabidopsis*. HrpN application increases endogenous ABA levels and activates ABA signaling, and results in increased drought tolerance. HrpN application fails to activate ABA signaling in the *abi2-1* mutant, which are resistant to *P. syringae* pv. *tomato* (Dong et al. 2005). These results suggest that HrpN stimulates ABA accumulation and ABA signaling in an ABI2-dependent manner to develop drought tolerance, which is distinct from the mechanism of resistance to bacterial infection. These results indicate that ABA should be added to the complex network of SA/JA/ethylene to regulate biotic and abiotic stress responses positively or negatively. Figure 2 and Table 1 summarize some of these interactions in terms of key mutants that have proved instrumental in providing insight into complex physiological processes during germination and seedling growth. Figure 3 also illustrates the interactions between abiotic- and biotic stresses that are mediated by ABA.

Fig. 2. Schematic of signaling pathways that interact with ABA regulation of germination. *Arrows* represent promotion of processes or expression of the regulators. *Bars* represent inhibitors of the indicated processes. Positions of loci do not imply order of gene action. Note that PKABA1, GAMyb and SLN are barley genes (Reprinted from Finkelstein et al. 2002. With permission).

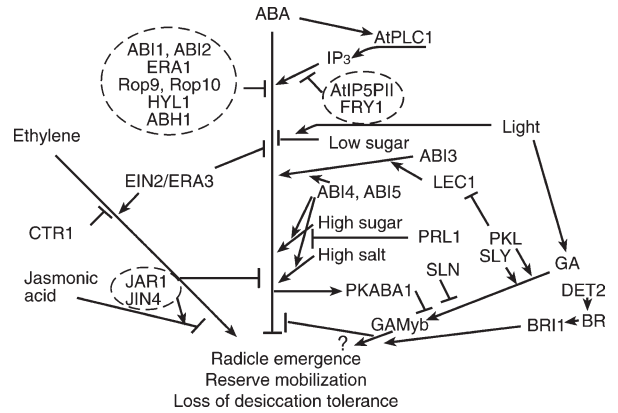

Table 1. Select mutants defective in ABA synthesis or responses that laid the groundwork for insights into the roles of ABA in growth, development and hormone crosstalk.

Species	Mutation/ AGI	ABA phenotype	Alleles or orthologs	Gene product	References (mostly prior to 2002)
<i>Arabidopsis thaliana</i>	<i>aba1</i>	ABA-deficient	<i>los6</i>	Zeaxanthin epoxidase	Koornneef et al. (1982); Xiong et al. (2001b)
	AT5G67030		<i>npq2</i>		Niyogi et al. (1998)
	<i>aba2</i>	ABA-deficient	<i>gin1</i> <i>isi4</i> <i>sis4</i>	Xanthoxin oxidase; short-chain dehydrogenase/reductase	Leon-Kloosterziel et al. (1996); Laby et al. (2000); Rook et al. (2001)
	AT1G52340				
	<i>aba3</i>	ABA-deficient	<i>frs1</i> <i>los5</i>	Aldehyde oxidase-molybdenum cofactor sulfurase	Leon-Kloosterziel et al. (1996); Llorente et al. (2000); Rook et al. (2001); Xiong et al. (2001b); Wollers et al. (2008)
	AT1G16540				
	AT2G27150				
	AT1G04580				
	<i>aoa3, aao4</i>	ABA-deficient		ABA aldehyde oxidase	Seo et al. (2000, 2006)
	<i>aba4</i>	ABA-deficient, reduced photoprotection		Intramolecular carotenoid oxidoreductase activity	Dall'Osto et al. (2007); North et al. (2007)
	AT1G67080				
	<i>abi1-1</i>	ABA-resistant (pleiotropic)		Protein phosphatase 2C	Koornneef et al. (1984); Leung et al. (1994); Meyer et al. (1994); Moes et al. (2008)
	AT4G26080				
	<i>abi2-1</i>	ABA-resistant (pleiotropic)		Protein phosphatase 2C	Koornneef et al. (1984); Leung et al. (1997); Rodriguez et al. (1998)
	AT5G57050				
	<i>abi3</i>	ABA-resistant	Cereal <i>VP1</i>	B3 domain transcription factor	Koornneef et al. (1984); Giraudat et al. (1992)
	AT3G24650				
	<i>abi4</i>	ABA-resistant	<i>gin6</i> <i>isi3</i> <i>san5</i> <i>sis5</i> <i>sun6</i>	APETALA2-domain transcription factor	Finkelstein (1994); Finkelstein et al. (1998); Arenas-Huertero et al. (2000); Huijser et al. (2000); Laby et al. (2000); Rook et al. (2001); Dekkers et al. (2008)
	AT2G40220				
	<i>abi5</i>	ABA-resistant	AtDPBF1 <i>gia1</i>	bZIP domain transcription factor	Finkelstein, (1994); Finkelstein and Lynch (2000); Lopez-Molina and Chua (2000); Garcia et al. (2008)
	AT2G36270				
	<i>afp1,2,4</i>	ABI5/ABF-binding protein; ABA-hypersensitive	TMAC2	Molecular function unknown	Lopez-Molina et al. (2003); Huang and Wu (2007); Garcia et al. (2008)
	AT1G69260				
	AT1G13740				
	AT3G02140				
	<i>myb44</i>	Drought/salt sensitivity; ABA-induced		MYB transcription factor	Huang et al. (2007); Jung et al. (2008)
	AT5G67300				

(continued)

Table 1. (continued)

Species	Mutation/ AGI	ABA phenotype	Alleles or orthologs	Gene product	References (mostly prior to 2002)
	<i>abi8</i> AT3G08550	ABA-resistant	<i>eld1</i> <i>kob1</i>	Molecular function unknown; cellulose biosynthesis	Brocard-Gifford et al. (2004)
	<i>abh1</i> AT2G13540	ABA-hypersensitive (pleiotropic)	CBP80	mRNA CAP-binding protein subunit	Hugouvieux et al. (2001); Gregory et al. (2008)
	<i>cbp20</i> AT5G44200	ABA-hypersensitive (pleiotropic)		mRNA CAP-binding protein subunit	Papp et al. (2004)
	<i>eral</i> AT5G40280	ABA-hypersensitive (pleiotropic)	<i>wiggum</i> <i>suppressor</i> <i>of npr1</i>	Farnesyl transferase, subunit	Cutler et al. (1996); Dekkers et al. (2008); Johnson et al. (2005); Wang et al. (2005); Goritschnig et al. (2008)
	<i>era3</i> AT5G03280	ABA-hypersensitive (pleiotropic)	<i>ein2</i> <i>ckr1</i> <i>pir2</i>	Membrane-bound metal sensor?; Auxin polar transport	Alonso et al. (1999); Ghassemian et al. (2000); Adie et al. (2007); Negi et al. (2008); Wang et al. (2007)
	<i>tmm</i> At1g80080	Too many mouths; ABA insensitive to chlorosis	<i>AtRLP17</i>	LRR-receptor-like protein	Wang et al. (2008a)
	<i>AtRLP41</i> At3g25010	ABA hypersensitive to chlorosis; senescence-induced		LRR-receptor-like protein	Wang et al. (2008a)
	<i>icmta</i> AT5G23320	ABA-hypersensitive (pleiotropic)		Isoprenyl cysteine Methyltransferase	Bracha-Drori et al. (2008)
	<i>hos1</i> AT2G39810	Deregulated reporter expression		RING finger protein	Lee et al. (2001); Dong et al. (2006)
	<i>hos2</i> AT5G63980	Deregulated reporter expression	<i>fiery1</i> <i>sal1</i>	3',2',5'-bisphosphate nucleotidase; Inositol polyphosphate 1-phosphatase	Quintero et al. (1996); Xiong et al. (2004); Gy et al. (2007)
	<i>hos10</i> AT1G35515	Deregulated reporter expression	MYB8	R2R3-MYB transcription factor	Zhu et al. (2005)
	<i>Hsp17.6A</i> AT5G12030	ABA insensitivity of seeds when overex- pressed;		Heat shock protein	Papdi et al. (2008)
	<i>ost1</i> AT4G33950	Open stomata	SNRK2-6 <i>V. faba</i> AAPK	Calcium-independent ABA-activated protein kinase	Li and Assmann (1996); Li et al. (2000); Mustilli et al. (2002)
	<i>mkk1</i> AT4G26070	ABA-insensitive in germination		Mitogen-activated kinase kinase	Qiu et al. (2008); Xing et al. (2008)
	<i>sad1</i> AT5G48870	Deregulated reporter expression, Reduced ABA biosynthesis, hypersensitive to ABA		U6-related Sm like small ribonucleoprotein	Xiong et al. (2001)
	<i>cla1</i> AT4G15560	ABA-deficient; albino		1-deoxy-D-xylulose- 5-phosphate synthase	Estévez et al. (2000)
	<i>hyll</i> AT1G09700	Hypersensitive to ABA; pleiotropic		dsRNA-binding protein; miRNA biogenesis	Lu and Fedoroff (2000); Song et al. (2007)
	<i>axr2</i> AT3G23050	Resistant to ABA, auxin and ethylene; dominant neg.	IAA7	Transcription regulator	Wilson et al. (1990); Nagpal et al. (2000); Nakamura et al. (2006)
	<i>bri1</i> AT4G39400	ABA hypersensitive, BR-insensitive	<i>bin1</i> <i>cbb2</i> <i>dwf2</i>	S/T-protein kinase	Li and Chory, (1997); Steber and McCourt (2001)

(continued)

Table 1. (continued)

Species	Mutation/ AGI	ABA phenotype	Alleles or orthologs	Gene product	References (mostly prior to 2002)
	<i>ibr5</i> AT2G04550	INDOLE-3-BUTYRIC ACID RESPONSE5; ABA insensitive		Tyr/ser/thr protein phosphatase	Strader et al. (2008)
	<i>det2</i> AT2G38050	ABA hypersensitive, de-etiolated	<i>dwf6</i>	Steroid reductase	Steber and McCourt (2001)
	<i>jar1</i> AT2G46370	Hypersensitive to ABA, JA-resistant			Staswick et al. (1992); Berger et al. (1996)
	<i>lec1</i> AT1G21970	slightly ABA resistant	<i>emb212</i>	CCAAT-box binding, HAP3 homolog	Meinke et al. (1994); Parcy et al. (1997); Lotan et al. (1998)
	<i>los1</i> AT1G56070	Deregulated reporter expression		Translation elongation factor 2-like	Guo et al. (2002)
	<i>pr11</i> AT4G15900	Hypersensitive to ABA (also to cytokinin, ethyl- ene, auxin, & sugars)		Nuclear WD40- domain protein	Nemeth et al. (1998); Bhalerao et al. (1999); Li et al. (2007); Lee et al. (2008c)
	<i>pdr3</i> AT2G29940	pleiotropic drug resist- ance 3 ABA-insensitive stomata		Transporter	Galbiati et al. (2008)
	<i>hat1</i>	ABA hypersensitive	<i>harmattan</i> <i>tolerant 1</i>		Yan et al. (2006a)
	<i>sax1</i>	ABA- and auxin-hyper- sensitive, BR-deficient			Ephritikhine et al. (1999)
	<i>gca1, gca2</i>	ABA-resistant (pleio- tropic)			Pei et al. (2000); Chung and Parish (2008)
	<i>gca3-gca8</i>	ABA-resistant root growth			Himmelbach et al. (1998)
	<i>ade1</i>	Deregulated reporter expression			Foster and Chua (1999)
	<i>hlq, sbr</i>	Deregulated reporter expression			Subramanian et al. (2002)
<i>Craterostigma</i> <i>plantagineum</i>	<i>cdt-1</i>	Constitutive ABA response in callus cultures		Regulatory siRNA	Furini et al. (1997); Phillips et al. (2007); Hilbricht et al. (2008a)
<i>Triticum</i> <i>aestivum</i>	<i>ABA27</i>	ABA hypersensitive			Kobayashi et al. (2008a, b, c)
<i>Hordeum</i> <i>vulgare</i>	<i>cool</i>	ABA-insensitivity in guard cells			Raskin and Ladyman (1988)
<i>Zea mays</i>	<i>vp1</i>	Viviparous, ABA- insensitive seeds	AtABI3	B3-domain transcription factor	Robertson, (1955); McCarty et al. (1991)
	<i>vp14</i>	Viviparous, ABA- deficient	AtNCED3 AT3G14440	9-cis-neoxanthin epoxycarotenoid dioxygenase	Neill et al. (1986); Schwartz et al. (1997)
	<i>vp8</i>	Viviparous; altered anthocyanin and aleurone cell differentiation	AtAMP1 AT3G54720	Peptidase	Suzuki et al. (2008a)
	<i>rea</i>	ABA-resistant germination, occasional vivipary, red embryos			Sturaro et al. (1996)
<i>Oryza sativa</i>	<i>phs</i>	Pre-harvest sprouting, ABA-deficient		Phytoene desatu- rase, Zeta-carotene desaturase, Carotenoid isomerase, Lycopene beta-cyclase	Fang et al. (2008)

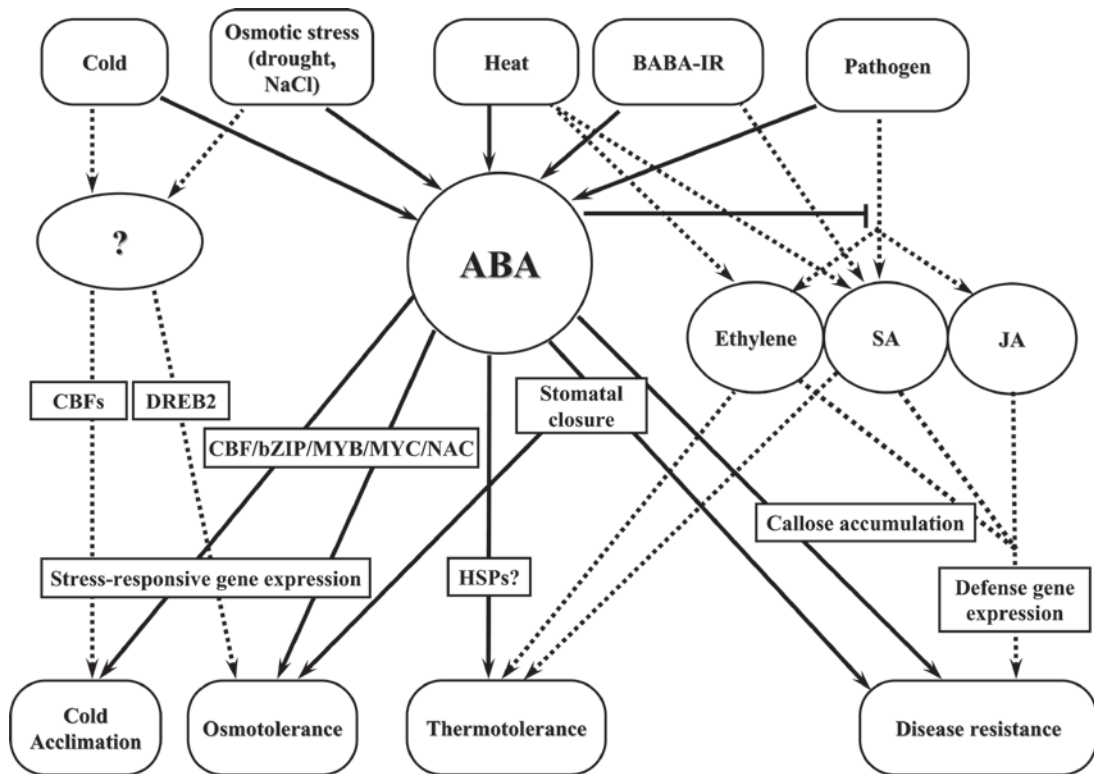

Fig. 3. Overview of signaling pathways between abiotic and biotic stresses. The figure shows signaling components involved in the response to abiotic and biotic factors. ABA-dependent and ABA-independent pathways are indicated by *black lines* and *dashed lines*, respectively.

### Box 3.2 Comparative Genomics Approaches to Stress Tolerance

With an increasing number of gene sequences becoming available, insights into genome and gene sequence evolution as well as the ancestral pathways of ABA biosynthesis and stress responses across the plant kingdom will further our understanding of these processes in seed plants. For example, poplar is a model organism for comparative plant genomics, forestry, and the seasonal cycling between growth, flowering, and dormancy. An unusual case of linkage disequilibrium for two *ABI1* orthologue haplotypes in poplar suggests that balancing selection may occur for ABA signaling (Garcia and Ingvarsson 2007). Several studies have shown natural variation in poplar ecotypes for various stress responses including drought and UV-B radiation tolerance (Ren et al. 2007). These genetic resources in combination with deep genomics such as stress-induced ESTs (Nanjo et al. 2004) can provide insight into evolution of stress tolerance.

ABA is ubiquitous in non-vascular plants and its signaling pathways are deeply conserved. The existence of phylogenetic footprints for *ABI3* and *FUS3* binding to spore-specific promoters of fern (Schallau et al. 2008) and the full or partial complementation of *abi3* phenotypes with a gymnosperm (Zeng and Kermode 2004) or moss (Marella et al. 2006) homologue suggests conservation of regulatory pathways controlling gene expression from bryophytes to angiosperm seeds. Availability of the *P. patens* genome sequence (Rensing et al. 2008) along with technologies such as RNAi (Harries et al. 2005), microarrays (Cuming et al. 2007), mapping (McDaniel 2009) and an inventory of microRNAs (Axtell and Bowman 2008) allows kingdom-wide comparative analysis



### Box 3.2 (continued)

of ABA signaling pathways (Quatrano et al. 2007). For example, the *P. patens* drought-responsive element binding (DREB) factor DBF1 transcripts from *P. patens* accumulate under various abiotic stresses and phytohormone treatments, and transgenic tobacco plants over-expressing PpDBF1 gained higher tolerance to salt, drought and cold stresses (Liu et al. 2007b). Interestingly, a wheat ABA-responsive *Em* gene promoter that has two copies of the ABRE is sufficient to confer ABA-inducible gene expression in the moss *P. patens* (Knight et al. 1995). DNaseI footprinting was used by Knight et al. (1995) to confirm that a moss nuclear factor bound specifically to the *Emla* site. In fact, they showed that a 10 bp region of DNA overlapped with part of the *Emla* site, defined in cereals by methylation interference (Guiltinan et al. 1990). The *abi1-1* allele of *Arabidopsis* was shown to functionally repress the ABA-dependent activation of a wheat *Em* gene promoter in the moss (Marella et al. 2006). Moreover, an ABA-responsive gene encoding a LEA protein (PpLEA1) was found to have an ACGT-containing ABRE similar to seed plants, and disruption of the ABRE-like motif diminished the ABA induction. Surprisingly, the PpLEA1 promoter failed to respond to ABA when introduced into barley aleurone cells (Kamisugi and Cuming 2005), suggesting a conserved but partly distinct ABA signaling pathway between the moss and angiosperms. Taken together, these results show the *P. patens* system is valuable for comparative structural and functional studies of ABA-response pathways.

## VIII Regulation of ABA Metabolism

The rates of ABA biosynthesis and catabolism within a tissue in response to abiotic stresses, as well as the mobility of ABA metabolites between cells and tissues, will determine the concentrations of the hormone and hence its impact in the response. ABA is a potential signal for cold-induced pollen sterility in rice by differential regulation of ABA biosynthesis and catabolism genes (Oliver et al. 2007). The phytoene synthase paralogue PSY3 is a rate-limiting enzyme for ABA biosynthesis in drought-stressed maize and rice roots (Li et al. 2008b; Welsch et al. 2008). A noninvasive, cell-autonomous reporter system has been developed which can monitor the generation and distribution of physiologically active pools of ABA (Christmann et al. 2005). The subject of ABA biosynthesis and catabolism, as well as regulation of ABA metabolism in relation to its physiological roles and tissue-specificity have been previously reviewed and is updated briefly here (Finkelstein and Rock 2002; Nambara and Marion-Poll 2005). With the recent cloning of *ABA4*, a single-copy gene in *Arabidopsis* that affects neoxanthin isomer production, the near complete pathway of stress-induced ABA biosynthesis from carotenoids has been elucidated genetically (Dall'Osto et al. 2007;

North et al. 2007) (Fig. 4). The *viviparous15* (*vp*) and *vp10* loci of maize encode molybdopterin synthase small subunit and CNX1, respectively, which act at the final common step of molybdenum cofactor (MoCo) synthesis required for ABA-aldehyde oxidation similar to ABA3 in *Arabidopsis* (Fig. 4) (Porch et al. 2006; Suzuki et al. 2006). The C-terminal domain of ABA3 might act as a scaffold protein where prebound desulfomolybdenum cofactor is converted into sulfurated cofactor prior to activation of aldehyde oxidase (Wollers et al. 2008).

Several genes involved in ABA catabolism have recently been elucidated. A novel pathway of ABA hydroxylation at the 9' position to give neophaseic acid in fruits, seeds and seedlings has been uncovered (Zhou et al. 2004), but the genes that catalyze this reaction are not yet known. The metabolites 7'- and 9'-hydroxy ABA and to a lesser extent 8'-ABA have hormonal activity in lipid synthesis in microspore-derived embryos of *Brassica napus* (Jadhav et al. 2008), suggesting that these ABA metabolites also have hormonal functions in ABA-regulated processes in plants. Genome-wide expression analyses of over 280 P450 monooxygenase genes in *Arabidopsis* revealed that CYP707A2 transcript abundance correlates with the rapid decrease in ABA level

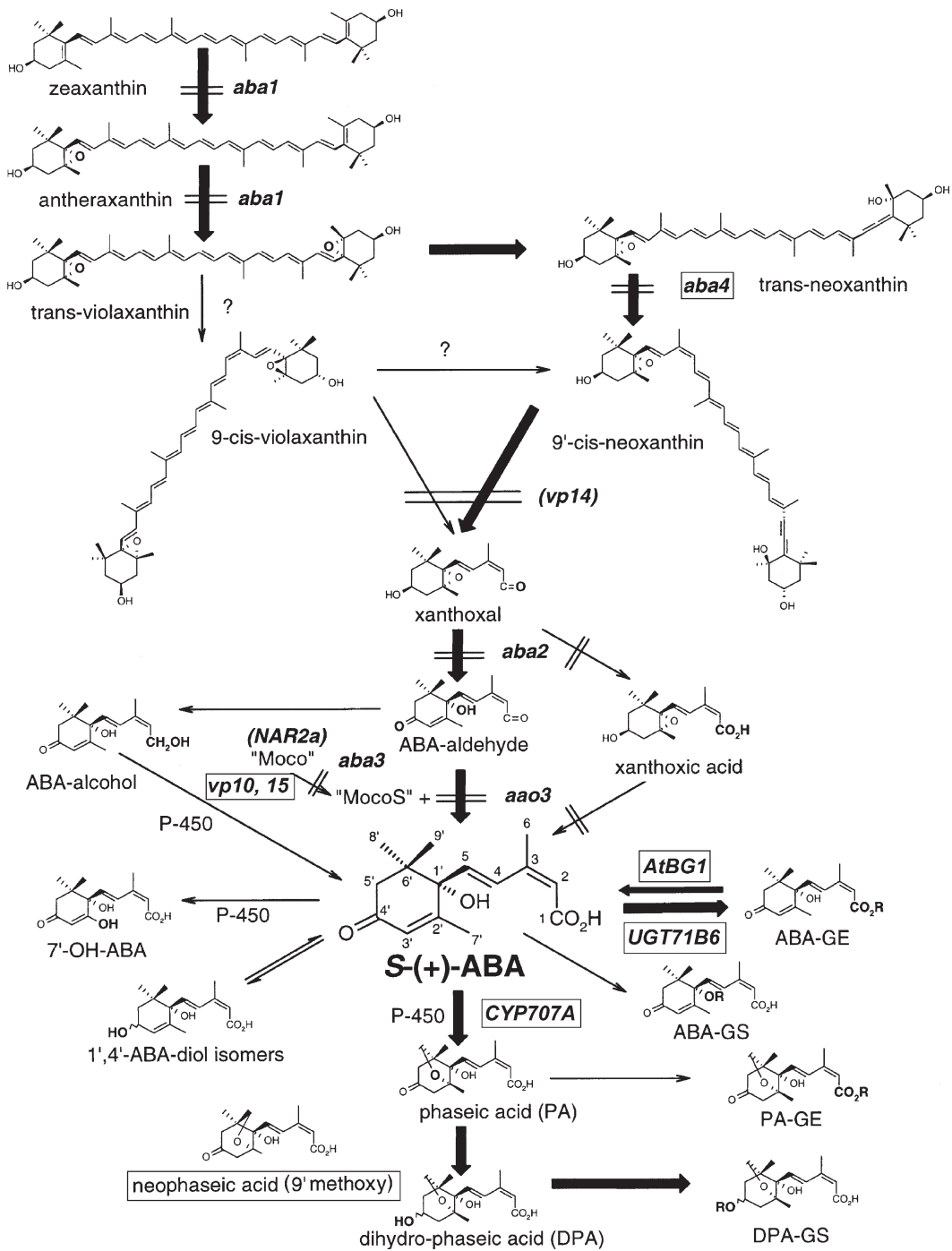

Fig. 4. Metabolic pathways of ABA after zeaxanthin, with positions of steps blocked in mutants indicated. Recently discovered genes are boxed (Modified from Finkelstein and Rock 2002).

during seed imbibition (Kushiro et al. 2004). During drought stress conditions, all four CYP707A homologs are up-regulated, and upon rehydration a significant increase in mRNA levels is observed. Insect cells expressing CYP707A3 efficiently metabolize (+)-ABA to yield phaseic acid, the isomerized form of 8'-hydroxy-ABA (Saito et al. 2004), thereby establishing that CYP707As are responsible for the major pathway of ABA catabolism by 8'-hydroxylation of (+)-ABA (Fig. 4). Similar results have been obtained with bean and barley homologs (Millar et al. 2006; Yang and Zeevaert 2006). *Cyp707a1* and *cyp707a2* knockout mutants of *Arabidopsis* exhibit ABA hyperdormancy in seeds and accumulate more ABA than wild type; expression patterns suggest A1 is involved in the mid-maturation phase of ABA decline and A2 in late maturation (Kushiro et al. 2004; Okamoto et al. 2006). Knockout mutants of *cyp707a3* contain higher ABA levels in turgid plants, reduced transpiration rates and hypersensitivity to exogenous ABA during early seedling growth, measured by ABA-inducible gene expression and enhanced drought tolerance (Umezawa et al. 2006). The finding that phytochrome controls CYP707A and NCED expression inversely to gibberellin biosynthetic genes provides insight into the molecular mechanism of photoreversibility of seed germination (Seo et al. 2006; Donohue et al. 2008; Sawada et al. 2008), and possibly leaf inclination (Mullen et al. 2006). PHYTOCHROME-INTERACTING FACTOR3-LIKE5 (PIL5) is a light-labile basic helix-loop-helix protein that increases ABA levels by activating ABA biosynthetic genes and repressing an ABA catabolic gene (Oh et al. 2007) via trans-activation of SOMNUS, a CCCH-type zinc finger protein important for light-regulation of germination (Kim et al. 2008a). Crosstalk between light and ABA responses in seed germination, early seedling growth and root development has been demonstrated recently by ABA-dependent HY5 transactivation of ABI5 and LEAs (Chen et al. 2008). Blue light promotes dormancy in freshly harvested cereal grains by promoting the expression *HvNCED1*, whereas dark or after-ripening promotes expression of ABA catabolic gene *HvABA8'-OH* (Gubler et al. 2008).

The flooding- and ethylene-induced cell elongation of deepwater rice has been extensively

studied as a model for vegetative ABA and gibberellin physiological activities. The rapid decrease in ABA levels in submerged rice shoots is controlled partly by ethylene-induced expression of OsABA8ox1 and partly by suppression of genes involved in the biosynthesis of ABA (Choi 2007; Saika et al. 2007). ABA antagonizes cytokinin and promotes senescence, which can be viewed as a type of cell death program activated during drought stress. Recent results showing that overexpression of cytokinin biosynthetic genes can promote drought tolerance (Rivero et al. 2007) suggesting that a complementary approach of modulating ABA metabolism in senescing leaves may also promote stress tolerance.

Uniconazole-P is a strong competitive inhibitor ( $K_i = 8.0$  nm) of ABA 8'-hydroxylase (Saito et al. 2006). ABA analogues have been synthesized that are competitive inhibitors of ABA-8'-hydroxylase and 9-cis-epoxycarotenoid dioxygenase, which provides new leads for non-azole plant growth regulators for stress adaptation, and reagents for ABA receptor and enzyme structure–function studies (Han et al. 2004; Araki et al. 2006; Kitahata et al. 2006; Nyangulu et al. 2006; Smith et al. 2006; Huang et al. 2007; 2008a; Ueno et al. 2007). Biotin-labeled ABA has been used to specifically probe binding sites on plasma membranes (Kitahata et al. 2005).

An ABA-specific UDP-glucosyl transferase (UGT71B6) has been characterized that when overexpressed leads to massive accumulation of ABA-GE and reduced levels of the oxidative metabolites PA and DPA (Priest et al. 2006). The recent discovery of a stress-inducible AtBETA GLUCOSIDASE1 (AtBG1) has challenged the long-held belief that conjugation of ABA to its biologically inactive glucose-ester is irreversible (Lee et al. 2006; Jiang and Hartung 2008), refocusing attention on the importance of catabolism underlying ABA accumulation, redistribution and sites of perception. Knockout mutants of AtBG1 exhibit defective stomatal movement, early germination, abiotic stress-sensitive phenotypes and lower ABA levels, whereas plants with ectopic AtBG1 accumulate higher ABA levels and display enhanced tolerance to abiotic stress. Dehydration rapidly induces polymerization of AtBG1 and increases its enzymatic activity (Lee et al. 2006).

NCED3 (VIVIPAROUS14 orthologue in maize) is one of a family of epoxycarotenoid dioxygenases that catalyze the rate-limiting step of ABA

biosynthesis (reviewed in Nambara and Marion-Poll 2005). AtNCED6 and AtNCED9 are required for ABA biosynthesis during seed development (Lefebvre et al. 2006). A MYB transcription factor, HIGH OSMOTIC STRESS10 (HOS10) is a positive effector of NCED3 expression in response to cold, salt and ABA (Zhu et al. 2005). The NCED3 maize orthologue VP14 is down-regulated in a *vp8* background, whereas the ZmABA 8'-hydroxylase gene is strongly up-regulated. VP8 encodes a putative peptidase closely related to *Arabidopsis* ALTERED MERISTEM PROGRAM1, suggesting that VP8 is required for synthesis of an unidentified signal that may integrate meristem formation and ABA-mediated embryo maturation (Suzuki et al. 2008a). The *XERICICO* gene encodes a protein with an N-terminal trans-membrane domain and a RING-H2 zinc-finger motif that positively regulates the *AtNCED3* gene (Ko et al. 2006). The downstream biosynthetic enzymes AtABA2 and AAO3 are localized constitutively in *Arabidopsis* vascular parenchyma cells at the boundary between xylem and phloem bundles, whereas the AtNCED3 protein is undetectable in these tissues except in water-stressed plants where it accumulates rapidly within 1 h and more broadly in mesophyll cells after several hours (Endo et al. 2008). There is evidence for an ABA-independent induction pathway for *NCED3* that is NaCl-dependent (Barrero et al. 2006). Overexpression of NCEDs in tomato increases transpiration efficiency, root hydraulic conductivity and net assimilation (Thompson et al. 2007).

An ABA-deficient mutant has been identified that encodes a zeta-carotene desaturase (Dong et al. 2007). Dissociation of neoxanthin from the major light-harvesting chlorophyll-a/b complex upon temperature increase is thought to provide a readily available substrate pool for synthesis of ABA during stress responses (Hobe et al. 2006). There are several carotenoid cleavage dioxygenases (CCDs) in *Arabidopsis* that do not participate in ABA biosynthesis. Interestingly, two of these (AtCCD7 and AtCCD8) have been shown to encode genes for *MAX3* and *MAX4* that produce a novel signaling molecule necessary for the regulation of lateral shoot branching (Schwartz et al. 2004; Auldridge et al. 2006). These genes may have applications for altering the growth habit of crops.

The *ABA1* locus encodes zeaxanthin epoxidase, the transcription of which in germinating seeds

is modulated by a putative glutamate receptor (AtGLR1.1) that functions with hexokinase HXK1 as a regulator of C and N metabolism (Kang et al. 2004). *ABA2* promoter activity is enhanced by multiple prolonged stresses such as drought, salinity, cold and flooding, but not by short-term stress treatments, suggesting a fine-tuning function of *ABA2* in ABA biosynthesis (Lin et al. 2007). The AAO3 gene catalyzes the last step of ABA biosynthesis and thus study of its tissue-specific expression can provide insight into ABA physiology. A transgenic ProAAO3::AAO3::GFP construct restores the wilted phenotype of the *aa03* mutant and GFP-fluorescence is detected in the root tips, vascular bundles of roots, hypocotyls and inflorescence stems, and most strongly in phloem companion cells as well as xylem parenchyma cells. These results indicate that the ABA synthesized in vascular systems is transported to various target tissues and cells, and also that the guard cells themselves are able to synthesize ABA (Koiwai et al. 2004).

## Acknowledgements

The authors thank Sean Cutler (U.C. Riverside) for sharing unpublished data. Work in the C.D.R. lab is supported by National Institutes of Health grant #GM077245.

## References

- Abe H, Yamaguchi-Shinozaki K, Urao T, Iwasaki T, Hosokawa D, Shinozaki K (1997) Role of *Arabidopsis* MYC and MYB homologs in drought- and abscisic acid-regulated gene expression. *Plant Cell* 9:1859–1868
- Abe H, Urao T, Ito T, Seki M, Shinozaki K, Yamaguchi-Shinozaki K (2003) *Arabidopsis* AtMYC2 (bHLH) and AtMYB2 (MYB) function as transcriptional activators in abscisic acid signaling. *Plant Cell* 15:63–78
- Addicott FT, Carns HR (1983) History and introduction. In: Addicott FT (ed) *Abscisic acid*. Praeger Scientific, New York, USA, pp 1–21
- Adie BA, Pérez-Pérez J, Pérez-Pérez MM, Godoy M, Sánchez-Serrano JJ, Schmelz EA, Solano R (2007) ABA is an essential signal for plant resistance to pathogens affecting JA biosynthesis and the activation of defenses in *Arabidopsis*. *Plant Cell* 19:1665–1681
- Allen GJ, Muir SR, Sanders D (1995) Release of Ca<sup>2+</sup> from individual plant vacuoles by both InsP<sub>3</sub> and cyclic ADP-ribose. *Science* 268:735–737



- Allen GJ, Kuchitsu K, Chu SP, Murata Y, Schroeder JI (1999) *Arabidopsis ABI1-1* and *ABI2-1* phosphatase mutations reduce abscisic acid-induced cytoplasmic calcium rises in guard cells. *Plant Cell* 11:1785–1798
- Alonso J, Hirayama T, Roman G, Nourizadeh S, Ecker J (1999) EIN2, a bifunctional transducer of ethylene and stress responses in *Arabidopsis*. *Science* 284:2148–2152
- Anderberg RJ, Walker-Simmons MK (1992) Isolation of a wheat cDNA clone for an abscisic acid-inducible transcript with homology to protein kinases. *Proc Natl Acad Sci USA* 89:10183–10187
- Anderson JP, Badruzaufari E, Schenk PM, Manners JM, Desmond OJ, Ehlert C, Maclean DJ, Ebert PR, Kazan K (2004) Antagonistic interaction between abscisic acid and jasmonate-ethylene signaling pathways modulates defense gene expression and disease resistance in *Arabidopsis*. *Plant Cell* 16:3460–3479
- Araki Y, Miyawaki A, Miyashita T, Mizutani M, Hirai N, Todoroki Y (2006) A new non-azole inhibitor of ABA 8-hydroxylase: Effect of the hydroxyl group substituted for geminal methyl groups in the six-membered ring. *Bioorg Medic Chem Letters* 16:3302–3305
- Arenas-Huetero F, Arroyo A, Zhou L, Sheen J, Leon P (2000) Analysis of *Arabidopsis* glucose insensitive mutants, *gin5* and *gin6*, reveals a central role of the plant hormone ABA in the regulation of plant vegetative development by sugar. *Genes Dev* 14:2085–2096
- Asselbergh B, De Vleeschauwer D, Hofte M (2008) Global switches and fine-tuning - ABA modulates plant pathogen defense. *Mol Plant Microbe Interact* 21:709–719
- Auldridge ME, Block A, Vogel JT, Dabney-Smith C, Mila I, Bouzayen M, Magallanes-Lundback M, DellaPenna D, McCarty DR, Klee HJ (2006) Characterization of three members of the *Arabidopsis* carotenoid cleavage dioxygenase family demonstrates the divergent roles of this multifunctional enzyme family. *Plant J* 45:982–993
- Avila EL, Brown M, Pan S, Desikan R, Neill SJ, Girke T, Surpin M, Raikhel NV (2008) Expression analysis of *Arabidopsis* vacuolar sorting receptor 3 reveals a putative function in guard cells. *J Exp Bot* 59:1149–1161
- Axtell MJ, Bowman JL (2008) Evolution of plant micro RNAs and their targets. *Trends Plant Sci* 13:343–349
- Barrero JM, Piqueras P, Gonzalez-Guzman M, Serrano R, Rodriguez PL, Ponce MR, Micol JL (2005) A mutational analysis of the *ABA1* gene of *Arabidopsis thaliana* highlights the involvement of ABA in vegetative development. *J Exp Bot* 56:2071–2083
- Barrero JM, Rodriguez PL, Quesada V, Piqueras P, Ponce MR, Micol JL (2006) Both abscisic acid (ABA)-dependent and ABA-independent pathways govern the induction of NCED3, AAO3 and ABA1 in response to salt stress. *Plant Cell Env* 29:2000–2008
- Barrero JM, Rodriguez PL, Quesada V, Alabadi D, Blazquez MA, Boutin JP, Marion-Poll A, Ponce MR, Micol JL (2008) The *ABA1* gene and carotenoid biosynthesis are required for late skotomorphogenic growth in *Arabidopsis thaliana*. *Plant Cell Env* 31:227–234
- Bartholomew DM, Bartley GE, Scolnik PA (1991) Abscisic-acid control of rbc<sub>s</sub> and cab transcription in tomato leaves. *Plant Physiol* 96:291–296
- Bassel GW, Fung P, Chow TFF, Foong JA, Provart NJ, Cutler SR (2008) Elucidating the germination transcriptional program using small molecules. *Plant Physiol* 147:143–155
- Bäurle I, Smith L, Baulcombe DC, Dean C (2007) Widespread role for the flowering-time regulators FCA and FPA in RNA-mediated chromatin silencing. *Science* 318:109–112
- Benedict C, Skinner JS, Meng R, Chang YJ, Bhalerao R, Huner NPA, Finn CE, Chen THH, Hurry V (2006) The CBF1-dependent low temperature signalling pathway, regulon and increase in freeze tolerance are conserved in *Populus* spp. *Plant Cell Env* 29:1259–1272
- Berger S, Bell E, Mullet J (1996) Two methyl jasmonate-insensitive mutants show altered expression of AtVsp in response to methyl jasmonate and wounding. *Plant Physiol* 111:525–531
- Besson-Bard A, Pugin A, Wendehenne D (2008) New insights into nitric oxide signaling in plants. *Ann Rev Plant Biol* 59:21–39
- Bezerra IC, Michaels SD, Schomburg FM, Amasino RM (2004) Lesions in the mRNA cap-binding gene *ABA HYPERSENSITIVE 1* suppress FRIGIDA-mediated delayed flowering in *Arabidopsis*. *Plant J* 40:112–119
- Bhalerao RP, Salchert K, Bako L, Okresz L, Szabados L, Muranaka T, Machida Y, Schell J, Koncz C (1999) Regulatory interaction of PRL1 WD protein with *Arabidopsis* SNF1-like protein kinases. *Proc Natl Acad Sci USA* 96:5322–5327
- Bonham-Smith PC, Kapoor M, Bewley JD (1987) Establishment of thermotolerance in maize by exposure to stresses other than a heat shock does not require heat shock protein synthesis. *Plant Physiol* 85:575–580
- Boudsocq M, Lauriere C (2005) Osmotic signaling in plants: multiple pathways mediated by emerging kinase families. *Plant Physiol* 138:1185–1194
- Bracha-Drori K, Shichrur K, Lubetzky TC, Yalovsky S (2008) Functional analysis of *Arabidopsis* postprenylation CaaX processing enzymes and their function in subcellular protein targeting. *Plant Physiol* 148:119–131
- Bright J, Desikan R, Hancock JT, Weir IS, Neill SJ (2006) ABA-induced NO generation and stomatal closure in *Arabidopsis* are dependent on H<sub>2</sub>O<sub>2</sub> synthesis. *Plant J* 45:113–122
- Brocard-Gifford I, Lynch TJ, Garcia ME, Malhotra B, Finkelstein RR (2004) The *Arabidopsis thaliana* ABSCISIC ACID-INSENSITIVE8 locus encodes a novel protein mediating abscisic acid and sugar responses essential for growth. *Plant Cell* 16:406–421
- Bruzzo S, Moreschi I, Usai C, Guida L, Damonte G, Salis A, Scarfi S, Millo E, De Flora A, Zocchi E (2007) Abscisic acid is an endogenous cytokine in human granulocytes with cyclic ADP-ribose as second messenger. *Proc Natl Acad Sci USA* 104:5759–5764



- Bruzzo S, Bodrato N, Usai C, Guida L, Moreschi I, Nano R, Antonioli B, Fruscione F, Magnone M, Scarfi S, De Flora A, Zocchi E (2008) Abscisic acid is an endogenous stimulator of insulin release from human pancreatic islets with cyclic ADP ribose as second messenger. *J Biol Chem* 283:32188–32197
- Bu QY, Jiang HL, Li CB, Zhai QZ, Zhang JY, Wu XQ, Sun JQ, Xie Q, Li CY (2008) Role of the *Arabidopsis thaliana* NAC transcription factors ANAC019 and ANAC055 in regulating jasmonic acid-signaled defense responses. *Cell Res* 18:756–767
- Carrera E, Holman T, Medhurst A, Dietrich D, Footitt S, Theodoulou FL, Holdsworth MJ (2008) Seed after-ripening is a discrete developmental pathway associated with specific gene networks in *Arabidopsis*. *Plant J* 53:214–224
- Castiglioni P, Warner D, Bensen RJ, Anstrom DC, Harrison J, Stoecker M, Abad M, Kumar G, Salvador S, D'Ordine R, Navarro S, Back S, Fernandes M, Targolli J, Dasgupta S, Bonin C, Luethy MH, Heard JE (2008) Bacterial RNA chaperones confer abiotic stress tolerance in plants and improved grain yield in maize under water-limited conditions. *Plant Physiol* 147:446–455
- Chang YC, Walling LL (1991) Abscisic-acid negatively regulates expression of chlorophyll a/b binding-protein genes during soybean embryogeny. *Plant Physiol* 97:1260–1264
- Chen TH, Gusta LV (1983) Abscisic acid-induced freezing resistance in cultured plant cells. *Plant Physiol* 73:71–75
- Chen ZZ, Hong XH, Zhang HR, Wang YQ, Li X, Zhu JK, Gong ZZ (2005) Disruption of the cellulose synthase gene, *AtCesA8/IRX1*, enhances drought and osmotic stress tolerance in *Arabidopsis*. *Plant J* 43:273–283
- Chen Y, Ji FF, Xie H, Liang JS, Zhang JH (2006) The regulator of G-protein signaling proteins involved in sugar and abscisic acid signaling in *Arabidopsis* seed germination. *Plant Physiol* 140:302–310
- Chen H, Zhang JY, Neff MM, Hong SW, Zhang HY, Deng XW, Xiong LM (2008) Integration of light and abscisic acid signaling during seed germination and early seedling development. *Proc Natl Acad Sci USA* 105:4495–4500
- Cherel I, Michard E, Platet N, Mouline K, Alcon C, Sentenac H, Thibaud JB (2002) Physical and functional interaction of the *Arabidopsis* K<sup>+</sup> channel *AKT2* and phosphatase *AtP2CA*. *Plant Cell* 14:1133–1146
- Chini A, Grant JJ, Seki M, Shinozaki K, Loake GJ (2004) Drought tolerance established by enhanced expression of the CC-NBS-LRR gene, *ADR1*, requires salicylic acid, *EDS1* and *ABI1*. *Plant J* 38:810–822
- Chinnusamy V, Zhu J, Zhu JK (2007) Cold stress regulation of gene expression in plants. *Trends Plant Sci* 12:444–451
- Chitteti BR, Peng ZH (2007) Proteome and phosphoproteome differential expression under salinity stress in rice (*Oryza sativa*) roots. *J Proteome Res* 6:1718–1727
- Cho SK, Ryu MY, Song C, Kwak JM, Kim WT (2008) *Arabidopsis* PUB22 and PUB23 are homologous U-box E3 ubiquitin ligases that play combinatorial roles in response to drought stress. *Plant Cell* 20:1899–1914
- Choi D (2007) Ethylene-induced stem growth of deepwater rice is correlated with expression of gibberellin- and abscisic acid-biosynthetic genes. *J Plant Biol* 50:595–599
- Christmann A, Hoffmann T, Teplova I, Grill E, Muller A (2005) Generation of active pools of abscisic acid revealed by in vivo imaging of water-stressed *Arabidopsis*. *Plant Physiol* 137:209–219
- Chung S, Parish RW (2008) Combinatorial interactions of multiple cis-elements regulating the induction of the *Arabidopsis XERO2* dehydrin gene by abscisic acid and cold. *Plant J* 54:15–29
- Churchill GC, Reaney MJT, Abrams SR, Gusta LV (1998) Effects of abscisic acid and abscisic acid analogs on the induction of freezing tolerance of winter rye (*Secale cereale* L.) seedlings. *Plant Growth Regul* 25:35–45
- Cohen AC, Bottini R, Piccoli PN (2008) *Azospirillum brasilense* Sp 245 produces ABA in chemically-defined culture medium and increases ABA content in *Arabidopsis* plants. *Plant Growth Regul* 54:97–103
- Colcombet J, Hirt H (2008) *Arabidopsis* MAPKs: a complex signalling network involved in multiple biological processes. *Biochem J* 413:217–226
- Conrath U, Pieterse CM, Mauch-Mani B (2002) Priming in plant-pathogen interactions. *Trends Plant Sci* 7:210–216
- Cove DJ (2005) The moss *Physcomitrella patens*. *Ann Rev Genet* 39:339–358
- Cui XH, Hao FS, Chen H, Chen J, Wang XC (2008) Expression of the *Vicia faba* VtPIP1 gene in *Arabidopsis thaliana* plants improves their drought resistance. *J Plant Res* 121:207–214
- Cuming AC, Cho SH, Kamisugi Y, Graham H, Quatrano RS (2007) Microarray analysis of transcriptional responses to abscisic acid and osmotic, salt and drought stress in the moss, *Physcomitrella patens*. *New Phytol* 176:275–287
- Cutler S, Ghassemian M, Bonetta D, Cooney S, McCourt P (1996) A protein farnesyl transferase involved in abscisic acid signal transduction in *Arabidopsis*. *Science* 273:1239–1241
- Dall'Osto L, Cazzaniga S, North H, Marion-Poll A, Bassi R (2007) The *Arabidopsis aba4-1* mutant reveals a specific function for neoxanthin in protection against photooxidative stress. *Plant Cell* 19:1048–1064
- De Smet I, Zhang HM, Inze D, Beeckman T (2006) A novel role for abscisic acid emerges from underground. *Trends Plant Sci* 11:434–439
- de Torres-Zabala M, Truman W, Bennett MH, Lafforgue G, Mansfield JW, Egea PR, Bogre L, Grant M (2007) *Pseudomonas syringae* pv. tomato hijacks the *Arabidopsis* abscisic acid signalling pathway to cause disease. *EMBO J* 26:1434–1443
- Dekkers BJW, Schuurmans J, Smeekens SCM (2008) Interaction between sugar and abscisic acid signalling during early seedling development in *Arabidopsis*. *Plant Mol Biol* 67:151–167
- Deruere J, Jackson K, Garbers C, Soll D, DeLong A (1999) The RCN1-encoded A subunit of protein phosphatase 2A increases phosphatase activity in vivo. *Plant J* 20:389–399

- Desikan R, Hagenbeek D, Neill SJ, Rock CD (1999) Flow cytometry and surface plasmon resonance analyses demonstrate that the monoclonal antibody JIM19 interacts with a rice cell surface component involved in abscisic acid signalling in protoplasts. *FEBS Lett* 456:257–262
- Diedhiou CJ, Popova OV, Dietz KJ, Goldack D (2008) The SNF1-type serine-threonine protein kinase SAPK4 regulates stress-responsive gene expression in rice. *BMC Plant Biol* 8:49
- Ding L, Pandey S, Assmann SM (2008) *Arabidopsis* extra-large G proteins (XLGs) regulate root morphogenesis. *Plant J* 53:248–263
- Dombrecht B, Xue GP, Sprague SJ, Kirkegaard JA, Ross JJ, Reid JB, Fitt GP, Sewelam N, Schenk PM, Manners JM, Kazan K (2007) MYC2 differentially modulates diverse jasmonate-dependent functions in *Arabidopsis*. *Plant Cell* 19:2225–2245
- Dong HP, Yu H, Bao Z, Guo X, Peng J, Yao Z, Chen G, Qu S, Dong H (2005) The ABI2-dependent abscisic acid signalling controls HrpN-induced drought tolerance in *Arabidopsis*. *Planta* 221:313–327
- Dong CH, Agarwal M, Zhang Y, Xie Q, Zhu JK (2006) The negative regulator of plant cold responses, HOS1, is a RING E3 ligase that mediates the ubiquitination and degradation of ICE1. *Proc Natl Acad Sci USA* 103:8281–8286
- Dong HL, Deng Y, Mu JY, Lu QT, Wang YQ, Xu YY, Chu CC, Chong K, Lu CM, Zuo JR (2007) The *Arabidopsis* SPONTANEOUS CELL DEATH1 gene, encoding a zeta-carotene desaturase essential for carotenoid biosynthesis, is involved in chloroplast development, photoprotection and retrograde signalling. *Cell Res* 17:458–470
- Donohue K, Heschel MS, Butler CM, Barua D, Sharrock RA, Whitelam GC, Chiang GCK (2008) Diversification of phytochrome contributions to germination as a function of seed-maturation environment. *New Phytol* 177:367–379
- Downs JA, Jackson SP (2004) A means to a DNA end: the many roles of Ku. *Nat Rev Mol Cell Biol* 5:367–378
- Endo A, Sawada Y, Takahashi H, Okamoto M, Ikegami K, Koiwai H, Seo M, Toyomasu T, Mitsunashi W, Shinozaki K, Nakazono M, Kamiya Y, Koshiba T, Nambara E (2008) Drought induction of *Arabidopsis* 9-cis-epoxycarotenoid dioxygenase occurs in vascular parenchyma cells. *Plant Physiol* 147:1984–1993
- Ephritikhine G, Fellner M, Vannini C, Lapous D, Barbier-Brygoo H (1999) The *sax1* dwarf mutant of *Arabidopsis thaliana* shows altered sensitivity of growth responses to abscisic acid, auxin, gibberellins and ethylene and is partially rescued by exogenous brassinosteroid. *Plant J* 18:303–314
- Estévez JM, Cantero A, Romero C, Kawaide H, Jimenez LF, Kuzuyama T, Seto H, Kamiya Y, León P (2000) Analysis of the expression of *CLAI*, a gene that encodes the 1-deoxyxylulose 5-phosphate synthase of the 2-C-methyl-Derythritol-4-phosphate pathway in *Arabidopsis*. *Plant Physiol* 124:95–103
- Fan LM, Zhang W, Chen JG, Taylor JP, Jones AM, Assmann SM (2008) Abscisic acid regulation of guard-cell K<sup>+</sup> and anion channels in G beta- and RGS-deficient *Arabidopsis* lines. *Proc Natl Acad Sci USA* 105:8476–8481
- Fang J, Chai CL, Qian Q, Li CL, Tang JY, Sun L, Huang ZJ, Guo XL, Sun CH, Liu M, Zhang Y, Lu QT, Wang YQ, Lu CM, Han B, Chen F, Cheng ZK, Chu CC (2008) Mutations of genes in synthesis of the carotenoid precursors of ABA lead to pre-harvest sprouting and photo-oxidation in rice. *Plant J* 54:177–189
- Finkelstein RR (1994) Mutations at two new *Arabidopsis* ABA response loci are similar to the *abi3* mutations. *Plant J* 5:765–771
- Finkelstein RR (2006) Studies of abscisic acid perception finally flower. *Plant Cell* 18:786–791
- Finkelstein R, Lynch T (2000) The *Arabidopsis* abscisic acid response gene *ABI5* encodes a basic leucine zipper transcription factor. *Plant Cell* 12:599–609
- Finkelstein RR, Wang ML, Lynch TJ, Rao S, Goodman HM (1998) The *Arabidopsis* abscisic acid response locus *ABI4* encodes an APETALA2 domain protein. *Plant Cell* 10:1043–1054
- Finkelstein RR, Rock CD (2002) Abscisic acid biosynthesis and response. In: Somerville CR, Meyerowitz EM (eds) *The Arabidopsis Book*. American Society of Plant Biologists, Rockville, MD, doi: 10.1199/tab.0058, www.aspb.org/publications/arabidopsis/
- Finkelstein RR, Gampala SS, Rock CD (2002) Abscisic acid signaling in seeds and seedlings. *Plant Cell* 14(Suppl): S15–S45
- Finkelstein RR, Reeves W, Ariizumi T, Steber C (2008) Molecular aspects of seed dormancy. *Ann Rev Plant Biol* 59:387–415
- Flors V, Ton J, van Doorn R, Jakab G, Garcia-Agustin P, Mauch-Mani B (2008) Interplay between JA, SA and ABA signalling during basal and induced resistance against *Pseudomonas syringae* and *Alternaria brassicicola*. *Plant J* 54:81–92
- Foster R, Chua N-H (1999) An *Arabidopsis* mutant with deregulated ABA gene expression: implications for negative regulator function. *Plant J* 17:363–372
- Fujii H, Verslues PE, Zhu JK (2007) Identification of two protein kinases required for abscisic acid regulation of seed germination, root growth and gene expression in *Arabidopsis*. *Plant Cell* 19:485–494
- Fujita M, Fujita Y, Maruyama K, Seki M, Hiratsu K, Ohme-Takagi M, Tran LS, Yamaguchi-Shinozaki K, Shinozaki K (2004) A dehydration-induced NAC protein, RD26, is involved in a novel ABA-dependent stress-signaling pathway. *Plant J* 39:863–876
- Furihata T, Maruyama K, Fujita Y, Umezawa T, Yoshida R, Shinozaki K, Yamaguchi-Shinozaki K (2006) Abscisic acid-dependent multisite phosphorylation regulates the activity of a transcription activator AREB1. *Proc Natl Acad Sci USA* 103:1988–1993
- Furini A, Koncz C, Salamini F, Bartels D (1997) High level transcription of a member of a repeated gene family confers dehydration tolerance to callus tissue of *Craterostigma Plantagineum*. *EMBO J* 16:3599–3608
- Galbiati M, Simoni L, Pavesi G, Cominelli E, Francia P, Vavasseur A, Nelson T, Bevan M, Tonelli C (2008) Gene

- trap lines identify *Arabidopsis* genes expressed in stomatal guard cells. *Plant J* 53:750–762
- Galpaz N, Wang Q, Menda N, Zamir D, Hirschberg J (2008) Abscisic acid deficiency in the tomato mutant *high pigment 3* leading to increased plastid number and higher fruit lycopene content. *Plant J* 53:717–730
- Gao YJ, Zeng QN, Guo JJ, Cheng J, Ellis BE, Chen JG (2007) Genetic characterization reveals no role for the reported ABA receptor, GCR2, in ABA control of seed germination and early seedling development in *Arabidopsis*. *Plant J* 52:1001–1013
- Garcia MV, Ingvarsson PK (2007) An excess of non-synonymous polymorphism and extensive haplotype structure at the *PtABI1B* locus in European aspen (*Populus tremula*): a case of balancing selection in an obligately outcrossing plant? *Heredity* 99:381–388
- Garcia ME, Lynch T, Peeters J, Snowden C, Finkelstein R (2008) A small plant-specific protein family of ABI five binding proteins (AFPs) regulates stress response in germinating *Arabidopsis* seeds and seedlings. *Plant Mol Biol* 67:643–658
- Garcia-Mata C, Lamattina L (2002) Nitric oxide and abscisic acid cross talk in guard cells. *Plant Physiol* 128:790–792
- Ghassemian M, Nambara E, Cutler S, Kawaide H, Kamiya Y, McCourt P (2000) Regulation of abscisic acid signaling by the ethylene response pathway in *Arabidopsis*. *Plant Cell* 12:1117–1126
- Giraudat J, Hauge B, Valon C, Smalle J, Parcy F, Goodman H (1992) Isolation of the *Arabidopsis* *ABI3* gene by positional cloning. *Plant Cell* 4:1251–1261
- Goel AK, Lundberg D, Torres MA, Matthews R, Akimoto-Tomiya C, Farmer L, Dangl JL, Grant SR (2008) The *Pseudomonas syringae* type III effector HopAM1 enhances virulence on water-stressed plants. *Mol Plant Microbe Interact* 21:361–370
- Gonai T, Kawahara S, Tougou M, Satoh S, Hashiba T, Hirai N, Kawaide H, Kamiya Y, Yoshioka T (2004) Abscisic acid in the thermoinhibition of lettuce seed germination and enhancement of its catabolism by gibberellin. *J Exp Bot* 55:111–118
- Goritschnig S, Weihmann T, Zhang YL, Fobert P, McCourt P, Li X (2008) A novel role for protein farnesylation in plant innate immunity. *Plant Physiol* 148:348–357
- Gosti F, Beaudoin N, Serizet C, Webb AA, Vartanian N, Giraudat J (1999) ABI1 protein phosphatase 2C is a negative regulator of abscisic acid signaling. *Plant Cell* 11:1897–1910
- Gregory BD, O'Malley RC, Lister R, Ulrich MA, Tonti-Filippini J, Chen H, Millar AH, Ecker JR (2008) A link between RNA metabolism and silencing affecting *Arabidopsis* development. *Dev Cell* 14:854–866
- Grill E, Christmann A (2007) A plant receptor with a big family. *Science* 315:1676–1677
- Group M, Ichimura K, Shinozaki K, Tena G, Sheen J, Henry Y, Champion A, Kreis M, Zhang S, Hirt H, Wilson C, Heberle-Bors E, Ellis BE, Morris PC, Innes RW, Ecker JR, Scheel D, Klessig DF, Machida Y, Mundy J, Ohashi Y, Walker JC (2002) Mitogen-activated protein kinase cascades in plants: a new nomenclature. *Trends Plant Sci* 7:301–308
- Guan LM, Zhao J, Scandalios JG (2000) Cis-elements and trans-factors that regulate expression of the maize *CAT1* antioxidant gene in response to ABA and osmotic stress: H<sub>2</sub>O<sub>2</sub> is the likely intermediary signaling molecule for the response. *Plant J* 22:87–95
- Gubler F, Hughes T, Waterhouse P, Jacobsen J (2008) Regulation of dormancy in barley by blue light and after-ripening: Effects on abscisic acid and gibberellin metabolism. *Plant Physiol* 147:886–896
- Guiltinan MJ, Marcotte WR Jr, Quatrano RS (1990) A plant leucine zipper protein that recognizes an abscisic acid element. *Science* 250:267–271
- Guo Y, Xiong L, Ishitani M, Zhu JK (2002) An *Arabidopsis* mutation in translation elongation factor 2 causes super-induction of CBF/DREB1 transcription factor genes but blocks the induction of their downstream targets under low temperatures. *Proc Natl Acad Sci USA* 99:7786–7791
- Guo J, Zeng Q, Emami M, Ellis BE, Chen J-G (2008) The *GCR2* gene family is not required for ABA control of seed germination and early seedling development in *Arabidopsis*. *PLoS ONE* 3:e2982. doi:10.1371/journal.pone.0002982
- Guri AJ, Hontecillas R, Si HW, Liu DM, Bassaganya-Riera J (2007) Dietary abscisic acid ameliorates glucose tolerance and obesity-related inflammation in db/db mice fed high-fat diets. *Clin Nutr* 26:107–116
- Gusta LV, Fowler DB, Tyler NJ (1982) The effect of abscisic acid and cytokinins on the cold hardiness of winter wheat. *Can J Bot* 60:301–305
- Gusta L, Trischuk R, Weiser CJ (2005) Plant cold acclimation: the role of abscisic acid. *J Plant Growth Regul* 24:308–318
- Gy I, Gasciolli V, Laressergues D, Morel JB, Gombert J, Proux F, Proux C, Vaucheret H, Mallory AC (2007) *Arabidopsis* FIERY1, XRN2, and XRN3 are endogenous RNA silencing suppressors. *Plant Cell* 19:3451–3461
- Haake V, Cook D, Riechmann JL, Pineda O, Thomashow MF, Zhang JZ (2002) Transcription factor CBF4 is a regulator of drought adaptation in *Arabidopsis*. *Plant Physiol* 130:639–648
- Han S, Tang R, Anderson LK, Woerner TE, Pei ZM (2003) A cell surface receptor mediates extracellular Ca<sup>2+</sup> sensing in guard cells. *Nature* 425:196–200
- Han SY, Kitahata N, Saito T, Kobayashi M, Shinozaki K, Yoshida S, Asami T (2004) A new lead compound for abscisic acid biosynthesis inhibitors targeting 9-cis-epoxycarotenoid dioxygenase. *Bioorg Med Chem Lett* 14:3033–3036
- Harries P, Pan A, Quatrano RS (2005) Actin-related protein2/3 complex component ARPC1 is required for proper cell morphogenesis and polarized cell growth in *Physcomitrella patens*. *Plant Cell* 17:2327–2339
- Hatano S, Sadakane H, Tutumi M, Watanabe T (1976) Studies on frost hardiness in *Chlorella ellipsoidea*. I. Development

- of frost hardiness of *Chlorella ellipsoidea* in synchronous culture. *Plant Cell Physiol* 17:451–458
- He HQ, Li JX (2008) Proteomic analysis of phosphoproteins regulated by abscisic acid in rice leaves. *Biochem Biophys Res Comm* 371:883–888
- He XJ, Mu RL, Cao WH, Zhang ZG, Zhang JS, Chen SY (2005) AtNAC2, a transcription factor downstream of ethylene and auxin signaling pathways, is involved in salt stress response and lateral root development. *Plant J* 44:903–916
- Hilbricht T, Varotto S, Sgaramella V, Bartels D, Salamini F, Furini A (2008) Retrotransposons and siRNA have a role in the evolution of desiccation tolerance leading to resurrection of the plant *Craterostigma plantagineum*. *New Phytol* 179:877–887
- Himmelbach A, Iten M, Grill E (1998) Signalling of abscisic acid to regulate plant growth. *Phil Trans Royal Soc London B Biol Sci* 353:1439–1444
- Hobe S, Trostmann I, Raunser S, Paulsen H (2006) Assembly of the major light-harvesting chlorophyll-a/b complex - thermodynamics and kinetics of neoxanthin binding. *J Biol Chem* 281:25156–25166
- Hong YY, Pan XQ, Welti R, Wang XM (2008) Phospholipase D alpha 3 is involved in the hyperosmotic response in *Arabidopsis*. *Plant Cell* 20:803–816
- Hornberg C, Weiler EW (1984) High-affinity binding-sites for abscisic-acid on the plasmalemma of *Vicia faba* guard-cells. *Nature* 310:321–324
- Hu H, Dai M, Yao J, Xiao B, Li X, Zhang Q, Xiong L (2006) Overexpressing a NAM, ATAF and CUC (NAC) transcription factor enhances drought resistance and salt tolerance in rice. *Proc Nat Acad Sci USA* 103:12987–12992
- Hu H, You J, Fang Y, Zhu X, Qi Z, Xiong L (2008) Characterization of transcription factor gene *SNAC2* conferring cold and salt tolerance in rice. *Plant Mol Biol* 67:169–181
- Huang MD, Wu WL (2007) Overexpression of TMAC2, a novel negative regulator of abscisic acid and salinity responses, has pleiotropic effects in *Arabidopsis thaliana*. *Plant Mol Biol* 63:557–569
- Huang DQ, Jaradat MR, Wu WR, Ambrose SJ, Ross AR, Abrams SR, Cutler AJ (2007) Structural analogs of ABA reveal novel features of ABA perception and signaling in *Arabidopsis*. *Plant J* 50:414–428
- Huang DQ, Wu WR, Abrams SR, Cutler AJ (2008a) The relationship of drought-related gene expression in *Arabidopsis thaliana* to hormonal and environmental factors. *J Exp Bot* 59:2991–3007
- Huang J, Wang MM, Jiang Y, Bao YM, Huang X, Sun H, Xu DQ, Lan HX, Zhang HS (2008b) Expression analysis of rice A20/AN1-type zinc finger genes and characterization of *ZFP177* that contributes to temperature stress tolerance. *Gene* 420:135–144
- Hugouvieux V, Kwak J, Schroeder J (2001) A mRNA cap binding protein, ABH1, modulates early abscisic acid signal transduction in *Arabidopsis*. *Cell* 106:477–487
- Huijser C, Kortstee A, Pego J, Weisbeek P, Wisman E, Smeeckens S (2000) The *Arabidopsis* *SUCROSE UNCOUPLED-6* gene is identical to *ABSCISIC ACID INSENSITIVE-4*: involvement of abscisic acid in sugar responses. *Plant J* 23:577–585
- Hwa CM, Yang XC (2008) The AtMKK3 pathway mediates ABA and salt signaling in *Arabidopsis*. *Acta Physiologiae Plantarum* 30:277–286
- Ichimura K, Mizoguchi T, Yoshida R, Yuasa T, Shinozaki K (2000) Various abiotic stresses rapidly activate *Arabidopsis* MAP kinases ATMPK4 and ATMPK6. *Plant J* 24:655–665
- Irving RM, Lanphear FO (1968) Regulation of cold hardiness in *Acer negundo*. *Plant Physiol* 43:9–13
- Iwama A, Yamashino T, Tanaka Y, Sakakibara H, Kakimoto T, Sato S, Kato T, Tabata S, Nagatani A, Mizuno T (2007) AHK5 histidine kinase regulates root elongation through an ETR1-dependent abscisic acid and ethylene signaling pathway in *Arabidopsis thaliana*. *Plant Cell Physiol* 48:375–380
- Jadhav AS, Taylor DC, Giblin M, Ferrie AM, Ambrose SJ, Ross AR, Nelson KM, Irina Zaharia L, Sharma N, Anderson M, Fobert PR, Abrams SR (2008) Hormonal regulation of oil accumulation in *Brassica* seeds: Metabolism and biological activity of ABA, 7-, 8- and 9-hydroxy ABA in microspore derived embryos of *B. napus*. *Phytochemistry* 147:528–542
- Jakab G, Ton J, Flors V, Zimmerli L, Metraux JP, Mauch-Mani B (2005) Enhancing *Arabidopsis* salt and drought stress tolerance by chemical priming for its abscisic acid responses. *Plant Physiol* 139:267–274
- Jang JY, Kim DG, Kim YO, Kim JS, Kang HS (2004) An expression analysis of a gene family encoding plasma membrane aquaporins in response to abiotic stresses in *Arabidopsis thaliana*. *Plant Mol Biol* 54:713–725
- Jang YH, Lee JH, Kim JK (2008) Abscisic acid does not disrupt either the *Arabidopsis* FCA-FY interaction or its rice counterpart in vitro. *Plant Cell Physiol* 49:1898–1901
- Jia F, Gampala SSL, Mittal A, Luo Q-J, Rock CD (2009) Cre-lox Univector acceptor vectors for functional screening in protoplasts: analysis of *Arabidopsis* donor cDNAs encoding ABSCISIC ACID INSENSITIVE1-Like protein phosphatases. *Plant Mol Biol* 70:693–708
- Jiang F, Hartung W (2008) Long-distance signalling of abscisic acid (ABA): the factors regulating the intensity of the ABA signal. *J Exp Bot* 59:37–43
- Johnson RR, Wagner RL, Verhey SD, Walker-Simmons MK (2002) The abscisic acid-responsive kinase PKABA1 interacts with a seed-specific abscisic acid response element-binding factor, TaABF, and phosphorylates TaABF peptide sequences. *Plant Physiol* 130:837–846
- Johnson KL, Jones BJ, Bacic A, Schultz CJ (2003) The fasciclin-like arabinogalactan proteins of *Arabidopsis*: A multigene family of putative cell adhesion molecules. *Plant Physiol* 133:1911–1925



- Johnson CD, Chary SN, Chernoff EA, Zeng Q, Running MP, Crowell DN (2005) Protein geranylgeranyltransferase I is involved in specific aspects of abscisic acid and auxin signaling in *Arabidopsis*. *Plant Physiol* 139:722–733
- Johnson RR, Shin M, Shen JQ (2008) The wheat PKABA1-interacting factor TaABF1 mediates both abscisic acid-suppressed and abscisic acid-induced gene expression in bombarded aleurone cells. *Plant Mol Biol* 68:93–103
- Johnston CA, Temple BR, Chen JG, Gao YJ, Moriyama EN, Jones AM, Siderovski DP, Willard FS (2007) Comment on “A G protein-coupled receptor is a plasma membrane receptor for the plant hormone abscisic acid”. *Science* 318:914
- Jones AM, Sussman MR (2009) A binding resolution. *Plant Physiol* 150:3–5
- Jorin JV, Maldonado AM, Castillejo MA (2007) Plant proteome analysis: A 2006 update. *Proteomics* 7:2947–2962
- Jung C, Seo JS, Han SW, Koo YJ, Kim CH, Song SI, Nahm BH, Do Choi Y, Cheong JJ (2008) Overexpression of AtMYB44 enhances stomatal closure to confer abiotic stress tolerance in transgenic *Arabidopsis*. *Plant Physiol* 146:623–635
- Kaldenhoff R, Ribas-Carbo M, Flexas J, Lovisolo C, Heckwolf M, Uehlein N (2008) Aquaporins and plant water balance. *Plant Cell Environ* 31:658–666
- Kamisugi Y, Cuming AC (2005) The evolution of the abscisic acid-response in land plants: comparative analysis of group 1 *LEA* gene expression in moss and cereals. *Plant Mol Biol* 59:723–737
- Kang JM, Mehta S, Turano FJ (2004) The putative glutamate receptor 1.1 (AtGLR1.1) in *Arabidopsis thaliana* regulates abscisic acid biosynthesis and signaling to control development and water loss. *Plant Cell Physiol* 45:1380–1389
- Khandelwal A, Elvitigala T, Ghosh B, Quatrano RS (2008) *Arabidopsis* transcriptome reveals control circuits regulating redox homeostasis and the role of an AP2 transcription factor. *Plant Physiol* 148:2050–2058
- Kim DH, Yamaguchi S, Lim S, Oh E, Park J, Hanada A, Kamiya Y, Choi G (2008a) SOMNUS, a CCCH-type zinc finger protein in *Arabidopsis*, negatively regulates light-dependent seed germination downstream of PIL5. *Plant Cell* 20:1260–1277
- Kim SG, Lee AK, Yoon HK, Park CM (2008b) A membrane-bound NAC transcription factor NTL8 regulates gibberellic acid-mediated salt signaling in *Arabidopsis* seed germination. *Plant J* 55:77–88
- Kitahata N, Nakano T, Kuchitsu K, Yoshida S, Asami T (2005) Biotin-labeled abscisic acid as a probe for investigating abscisic acid binding sites on plasma membranes of barley aleurone protoplasts. *Bioorg Med Chem* 13:3351–3358
- Kitahata N, Han SY, Noji N, Saito T, Kobayashi M, Nakano T, Kuchitsu K, Shinozaki K, Yoshida S, Matsumoto S, Tsujimoto M, Asami T (2006) A 9-cis-epoxycarotenoid dioxygenase inhibitor for use in the elucidation of abscisic acid action mechanisms. *Bioorg Med Chem* 14:5555–5561
- Knetsch M, Wang M, Snaar-Jagalska BE, Heimovaara-Dijkstra S (1996) Abscisic acid induces mitogen-activated protein kinase activation in barley aleurone protoplasts. *Plant Cell* 8:1061–1067
- Knight CD, Sehgal A, Atwal K, Wallace JC, Cove DJ, Coates D, Quatrano RS, Bahadur S, Stockley PG, Cuming AC (1995) Molecular responses to abscisic acid and stress are conserved between moss and cereals. *Plant Cell* 7:499–506
- Knight H, Zarka DG, Okamoto H, Thomashow MF, Knight MR (2004) Abscisic acid induces *CBF* gene transcription and subsequent induction of cold-regulated genes via the CRT promoter element. *Plant Physiol* 135:1710–1717
- Ko JH, Yang SH, Han KH (2006) Upregulation of an *Arabidopsis* RING-H2 gene, *XERICO*, confers drought tolerance through increased abscisic acid biosynthesis. *Plant J* 47:343–355
- Kobayashi Y, Murata M, Minami H, Yamamoto S, Kagaya Y, Hobo T, Yamamoto A, Hattori T (2005) Abscisic acid-activated SNRK2 protein kinases function in the gene-regulation pathway of ABA signal transduction by phosphorylating ABA response element-binding factors. *Plant J* 44:939–949
- Kobayashi F, Takumi S, Egawa C, Ishibashi M, Nakamura C (2006) Expression patterns of low temperature responsive genes in a dominant ABA-less-sensitive mutant line of common wheat. *Physiol Plantarum* 127:612–623
- Kobayashi F, Ishibashi M, Takumi S (2008a) Transcriptional activation of *Cor/Lea* genes and increase in abiotic stress tolerance through expression of a wheat DREB2 homolog in transgenic tobacco. *Transgenic Res* 17:755–767
- Kobayashi F, Maeta E, Terashima A, Kawaura K, Ogihara Y, Takumi S (2008b) Development of abiotic stress tolerance via bZIP-type transcription factor LIP19 in common wheat. *J Exp Bot* 59:891–905
- Kobayashi F, Takumi S, Nakamura C (2008c) Increased freezing tolerance in an ABA-hypersensitive mutant of common wheat. *J Plant Physiol* 165:224–232
- Koiwai H, Nakaminami K, Seo M, Mitsuhashi W, Toyomasu T, Koshiha T (2004) Tissue-specific localization of an abscisic acid biosynthetic enzyme, AAO3, in *Arabidopsis*. *Plant Physiol* 134:1697–1707
- Koornneef M, Jorna ML, Brinkhorst-van der Swan DLC, Karssen CM (1982) The isolation of abscisic acid (ABA) deficient mutants by selection of induced revertants in nongerminating gibberellin sensitive lines of *Arabidopsis thaliana* (L.) Heynh. *Theoret Appl Genet* 61:385–393
- Koornneef M, Reuling G, Karssen CM (1984) The isolation and characterization of abscisic-acid insensitive mutants of *Arabidopsis thaliana*. *Physiol Plantarum* 61:377–383
- Korolev N, David DR, Elad Y (2008) The role of phytohormones in basal resistance and *Trichoderma*-induced systemic resistance to *Botrytis cinerea* in *Arabidopsis thaliana*. *Biocontrol* 53:667–683



- Kotak S, Larkindale J, Lee U, von Koskull-Doring P, Vierling E, Scharf KD (2007) Complexity of the heat stress response in plants. *Curr Opin Plant Biol* 10:310–316
- Koussevitzky S, Nott A, Mockler TC, Hong F, Sachetto-Martins G, Surpin M, Lim IJ, Mittler R, Chory J (2007) Signals from chloroplasts converge to regulate nuclear gene expression. *Science* 316:715–719
- Kovtun Y, Chiu WL, Tena G, Sheen J (2000) Functional analysis of oxidative stress-activated mitogen-activated protein kinase cascade in plants. *Proc Nat Acad Sci USA* 97:2940–2945
- Kuhn JM, Boisson-Dernier A, Dizon MB, Maktabi MH, Schroeder JI (2006) The protein phosphatase AtPP2CA negatively regulates abscisic acid signal transduction in *Arabidopsis*, and effects of *abh1* on AtPP2CA mRNA. *Plant Physiol* 140:127–139
- Kuhn JM, Breton G, Schroeder JI (2007) mRNA metabolism of flowering-time regulators in wild-type *Arabidopsis* revealed by a nuclear cap binding protein mutant, *abh1*. *Plant J* 50:1049–1062
- Kurepin LV, Qaderi MM, Back TG, Reid DM, Pharis RP (2008) A rapid effect of applied brassinolide on abscisic acid concentrations in *Brassica napus* leaf tissue subjected to short-term heat stress. *Plant Growth Regul* 55:165–167
- Kushiro T, Okamoto M, Nakabayashi K, Yamagishi K, Kitamura S, Asami T, Hirai N, Koshihara T, Kamiya Y, Nambara E (2004) The *Arabidopsis* cytochrome P450 CYP707A encodes ABA 8-hydroxylases: key enzymes in ABA catabolism. *EMBO J* 23:1647–1656
- Kwak JM, Moon JH, Murata Y, Kuchitsu K, Leonhardt N, DeLong A, Schroeder JI (2002) Disruption of a guard cell-expressed protein phosphatase 2A regulatory subunit, RCN1, confers abscisic acid insensitivity in *Arabidopsis*. *Plant Cell* 14:2849–2861
- Kwak JM, Mori IC, Pei ZM, Leonhardt N, Torres MA, Dangel JL, Bloom RE, Bodde S, Jones JD, Schroeder JI (2003) NADPH oxidase *AtrbohD* and *AtrbohF* genes function in ROS-dependent ABA signaling in *Arabidopsis*. *EMBO J* 22:2623–2633
- Laby R, Kincaid M, Kim D, Gibson S (2000) The *Arabidopsis* sugar-insensitive mutants *sis4* and *sis5* are defective in abscisic acid synthesis and response. *Plant J* 23:587–596
- Lai CP, Lee CL, Chen PH, Wu SH, Yang CC, Shaw JF (2004) Molecular analyses of the *Arabidopsis* TUBBY-like protein gene family. *Plant Physiol* 134:1586–1597
- Lalk I, Dorffling K (1985) Hardening, abscisic acid, proline and freezing resistance in two winter wheat varieties. *Physiol Plantarum* 63:287–292
- Lang V, Mantyla E, Welin B, Sundberg B, Palva ET (1994) Alterations in water status, endogenous abscisic acid content, and expression of *RAB18* gene during the development of freezing tolerance in *Arabidopsis thaliana*. *Plant Physiol* 104:1341–1349
- Lapik YR, Kaufman LS (2003) The *Arabidopsis* cupin domain protein AtPirin1 interacts with the G protein alpha-subunit GPA1 and regulates seed germination and early seedling development. *Plant Cell* 15:1578–1590
- Larkindale J, Huang B (2004) Thermotolerance and antioxidant systems in *Agrostis stolonifera*: involvement of salicylic acid, abscisic acid, calcium, hydrogen peroxide and ethylene. *J Plant Physiol* 161:405–413
- Larkindale J, Knight MR (2002) Protection against heat stress-induced oxidative damage in *Arabidopsis* involves calcium, abscisic acid, ethylene, and salicylic acid. *Plant Physiol* 128:682–695
- Larkindale J, Hall JD, Knight MR, Vierling E (2005) Heat stress phenotypes of *Arabidopsis* mutants implicate multiple signaling pathways in the acquisition of thermotolerance. *Plant Physiol* 138:882–897
- Lee H, Xiong L, Gong Z, Ishitani M, Stevenson B, Zhu J-K (2001) The *Arabidopsis* *HOS1* gene negatively regulates cold signal transduction and encodes a RING finger protein that displays cold-regulated nucleo-cytoplasmic partitioning. *Genes Dev* 15:912–924
- Lee KH, Piao HL, Kim HY, Choi SM, Jiang F, Hartung W, Hwang I, Kwak JM, Lee IJ (2006) Activation of glucosylase via stress-induced polymerization rapidly increases active pools of abscisic acid. *Cell* 126:1109–1120
- Lee K, Song EH, Kim HS, Yoo JH, Han HJ, Jung MS, Lee SM, Kim KE, Kim MC, Cho MJ, Chung WS (2008a) Regulation of MAPK phosphatase 1 (AtMKP1) by calmodulin in *Arabidopsis*. *J Biol Chem* 283:23581–23588
- Lee U, Wie C, Fernandez BO, Feelisch M, Vierling E (2008b) Modulation of nitrosative stress by S-nitrosoglutathione reductase is critical for thermotolerance and plant growth in *Arabidopsis*. *Plant Cell* 20:786–802
- Lee JH, Terzaghi W, Gusmaroli G, Charron JB, Yoon HJ, Chen H, He YJ, Xiong Y, Deng XW (2008c) Characterization of *Arabidopsis* and rice DWD proteins and their roles as substrate receptors for CUL4-RING E3 ubiquitin ligases. *Plant Cell* 20:152–167
- Leeson EA, Cann JP, Snell JJ (1984) Maintenance of algae and protozoa. In: Kirsop BE, Snell JJ (eds) *Maintenance of microorganisms*. Academic, London, UK, pp 131–160
- Lefebvre V, North H, Frey A, Sotta B, Seo M, Okamoto M, Nambara E, Marion-Poll A (2006) Functional analysis of *Arabidopsis* *NCED6* and *NCED9* genes indicates that ABA synthesized in the endosperm is involved in the induction of seed dormancy. *Plant J* 45:309–319
- Léon-Kloosterziel KM, Alvarez-Gil M, Ruijs GJ, Jacobsen SE, Olszewski NE, Schwartz SH, Zeevaart JAD, Koornneef M (1996) Isolation and characterization of abscisic acid-deficient *Arabidopsis* mutants at two new loci. *Plant J* 10:655–661
- Leung J, Bouvier-Durand M, Morris PC, Guerrier D, Cheddor F, Giraudat J (1994) *Arabidopsis* ABA response gene *ABI1*: features of a calcium-modulated protein phosphatase. *Science* 264:1448–1452
- Leung J, Merlot S, Giraudat J (1997) The *Arabidopsis* *ABSCISIC ACID-INSENSITIVE2* (*ABI2*) and *ABI1* genes encode homologous protein phosphatases 2C involved in abscisic acid signal transduction. *Plant Cell* 9:759–771

- Li J, Assmann SM (1996) An abscisic acid-activated and calcium-independent protein kinase from guard cells of *Fava bean*. *Plant Cell* 8:2359–2368
- Li J, Chory J (1997) A putative leucine-rich repeat receptor kinase involved in brassinosteroid signal transduction. *Cell* 90:929–938
- Li J, Wang XQ, Watson MB, Assmann SM (2000) Regulation of abscisic acid-induced stomatal closure and anion channels by guard cell AAPK kinase. *Science* 287:300–303
- Li YH, Smith C, Corke F, Zheng LY, Merali Z, Ryden P, Derbyshire P, Waldron K, Bevan MW (2007) Signaling from an altered cell wall to the nucleus mediates sugar-responsive growth and development in *Arabidopsis thaliana*. *Plant Cell* 19:2500–2515
- Li AL, Zhu YF, Tan XM, Wang X, Wei B, Guo HZ, Zhang ZL, Chen XB, Zhao GY, Kong XY, Jia JZ, Mao L (2008a) Evolutionary and functional study of the CDPK gene family in wheat (*Triticum aestivum* L.). *Plant Mol Biol* 66:429–443
- Li FQ, Vallabhaneni R, Wurtzel ET (2008b) PSY3, a new member of the phytoene synthase gene family conserved in the poaceae and regulator of abiotic stress-induced root carotenogenesis. *Plant Physiol* 146:1333–1345
- Li WX, Oono Y, Zhu J, He XJ, Wu JM, Iida K, Lu XY, Cui X, Jin H, Zhu JK (2008c) The *Arabidopsis* NFYA5 transcription factor is regulated transcriptionally and post-transcriptionally to promote drought resistance. *Plant Cell* 20:2238–2251
- Liao Y, Zou HF, Wei W, Hao YJ, Tian AG, Huang J, Liu YF, Zhang JS, Chen SY (2008) Soybean *GmbZIP44*, *GmbZIP62* and *GmbZIP78* genes function as negative regulator of ABA signaling and confer salt and freezing tolerance in transgenic *Arabidopsis*. *Planta* 228:225–240
- Lin PC, Hwang SG, Endo A, Okamoto M, Koshiba T, Cheng WH (2007) Ectopic expression of *ABSCISIC ACID 2/GLUCOSE INSENSITIVE 1* in *Arabidopsis* promotes seed dormancy and stress tolerance. *Plant Physiol* 143:745–758
- Liu Q, Kasuga M, Sakuma Y, Abe H, Miura S, Yamaguchi-Shinozaki K, Shinozaki K (1998) Two transcription factors, DREB1 and DREB2, with an EREBP/AP2 DNA binding domain separate two cellular signal transduction pathways in drought- and low-temperature-responsive gene expression, respectively, in *Arabidopsis*. *Plant Cell* 10:1391–1406
- Liu HT, Liu YY, Pan QH, Yang HR, Zhan JC, Huang WD (2006) Novel interrelationship between salicylic acid, abscisic acid, and PIP2-specific phospholipase C in heat acclimation-induced thermotolerance in pea leaves. *J Exp Bot* 57:3337–3347
- Liu FQ, Quesada V, Crevillen P, Baurle I, Swiezewski S, Dean C (2007a) The *Arabidopsis* RNA-binding protein FCA requires a lysine-specific demethylase 1 homolog to downregulate FLC. *Mol Cell* 28:398–407
- Liu N, Zhong NQ, Wang GL, Li LJ, Liu XL, He YK, Xia GX (2007b) Cloning and functional characterization of *PpDBF1* gene encoding a DRE-binding transcription factor from *Physcomitrella patens*. *Planta* 226:827–838
- Liu XG, Yue YL, Li B, Nie YL, Li W, Wu WH, Ma LG (2007c) A G protein-coupled receptor is a plasma membrane receptor for the plant hormone abscisic acid. *Science* 315:1712–1716
- Liu XG, Yue YL, Li W, Ma LG (2007d) Response to comment on “A G protein-coupled receptor is a plasma membrane receptor for the plant hormone abscisic acid”. *Science* 318:914d
- Liu PF, Chang WC, Wang YK, Chang HY, Pan RL (2008a) Signaling pathways mediating the suppression of *Arabidopsis thaliana* Ku gene expression by abscisic acid. *Biochim Biophys Acta* 1779:164–174
- Liu PF, Wang YK, Chang WC, Chang HY, Pan RL (2008b) Regulation of *Arabidopsis thaliana* Ku genes at different developmental stages under heat stress. *Biochim Biophys Acta* 1779:402–407
- Llorente F, Oliveros JC, Martinez-Zapater JM, Salinas J (2000) A freezing-sensitive mutant of *Arabidopsis*, *frs1*, is a new *aba3* allele. *Planta* 211:648–655
- Lois LM, Lima CD, Chua NH (2003) Small ubiquitin-like modifier modulates abscisic acid signaling in *Arabidopsis*. *Plant Cell* 15:1347–1359
- Lopez MA, Bannenberg G, Castresana C (2008) Controlling hormone signaling is a plant and pathogen challenge for growth and survival. *Curr Opin Plant Biol* 11:420–427
- Lopez-Molina L, Chua N-H (2000) A null mutation in a bZIP factor confers ABA-insensitivity in *Arabidopsis thaliana*. *Plant Cell Physiol* 41:541–547
- Lopez-Molina L, Mongrand S, Chua NH (2001) A postgermination developmental arrest checkpoint is mediated by abscisic acid and requires the ABI5 transcription factor in *Arabidopsis*. *Proc Nat Acad Sci USA* 98:4782–4787
- Lopez-Molina L, Mongrand S, Kinoshita N, Chua NH (2003) AFP is a novel negative regulator of ABA signaling that promotes ABI5 protein degradation. *Gene Dev* 17:410–418
- Lorenzo O, Nicolas C, Nicolas G, Rodriguez D (2002) Molecular cloning of a functional protein phosphatase 2C (FsPP2C2) with unusual features and synergistically up-regulated by ABA and calcium in dormant seeds of *Fagus sylvatica*. *Physiol Plantarum* 114:482–490
- Lorenzo O, Chico JM, Sanchez-Serrano JJ, Solano R (2004) *Jasmonate-insensitive1* encodes a MYC transcription factor essential to discriminate between different jasmonate-regulated defense responses in *Arabidopsis*. *Plant Cell* 16:1938–1950
- Lotan T, Ohto M-A, Yee KM, West MAL, Lo R, Kwong RW, Yamagishi K, Fischer RL, Goldberg RB, Harada JJ (1998) *Arabidopsis* LEAFY COTYLEDON1 is sufficient to induce embryo development in vegetative cells. *Cell* 93:1195–1205
- Lu C, Fedoroff N (2000) A mutation in the *Arabidopsis* *HYL1* gene encoding a dsRNA binding protein affects responses to abscisic acid, auxin and cytokinin. *Plant Cell* 12:2351–2365

- Lu C, Han MH, Guevara-Garcia A, Fedoroff NV (2002) Mitogen-activated protein kinase signaling in postgermination arrest of development by abscisic acid. *Proc Nat Acad Sci USA* 99:15812–15817
- Lue B, Chen F, Gong ZH, Xie H, Zhang JH, Liang JS (2007) Intracellular localization of integrin-like protein and its roles in osmotic stress-induced abscisic acid biosynthesis in *Zea mays*. *Protoplasma* 232:35–43
- Lumba S, McCourt P (2005) Preventing leaf identity theft with hormones. *Curr Opin Plant Biol* 8:501–505
- Luo J, Shen G, Yan J, He C, Zhang H (2006) AtCHIP functions as an E3 ubiquitin ligase of protein phosphatase 2A subunits and alters plant response to abscisic acid treatment. *Plant J* 46:649–657
- Ma Y, Szostkiewicz I, Korte A, Moes D, Yang Y, Christmann A, Grill E (2009) Regulators of PP2C phosphatase activity function as abscisic acid sensors. *Science* 324:1064–1068
- Macknight R, Duroux M, Laurie R, Dijkwel P, Simpson G, Dean C (2002) Functional significance of the alternative transcript processing of the *Arabidopsis* floral promoter FCA. *Plant Cell* 14:877–888
- Marcotte WRJ, Bayley CC, Quatrano RS (1988) Regulation of a wheat promoter by abscisic acid in rice protoplasts. *Nature* 335:454–457
- Marcotte WRJ, Russell SH, Quatrano RS (1989) Abscisic acid responsive sequences from the *Em* gene of wheat. *Plant Cell* 1:969–976
- Marella HH, Sakata Y, Quatrano RS (2006) Characterization and functional analysis of *ABSCISIC ACID INSENSITIVE3*-like genes from *Physcomitrella patens*. *Plant J* 46:1032–1044
- Martinez-Zapater JM (1994) The transition to flowering in *Arabidopsis*. In: Meyerowitz EM, Somerville CR (eds) *Arabidopsis*. Cold Spring Harbor Laboratory Press, Plainview, New York, pp 403–433
- Matsui A, Ishida J, Morosawa T, Mochizuki Y, Kaminuma E, Endo TA, Okamoto M, Nambara E, Nakajima M, Kawashima M, Satou M, Kim JM, Kobayashi N, Toyoda T, Shinozaki K, Seki M (2008) *Arabidopsis* transcriptome analysis under drought, cold, high-salinity and ABA treatment conditions using a tiling array. *Plant Cell Physiol* 49:1135–1149
- Mauch-Mani B, Mauch F (2005) The role of abscisic acid in plant-pathogen interactions. *Curr Opin Plant Biol* 8:409–414
- McCarty DR, Hattori T, Carson CB, Vasil V, Lazar M, Vasil IK (1991) The VIVIPAROUS-1 developmental gene of maize encodes a novel transcriptional activator. *Cell* 66:895–905
- McCourt P, Creelman R (2008) The ABA receptors – we report you decide. *Curr Opin Plant Biol* 11:474–478
- McDaniel SF (2009) The genetic basis of natural variation in bryophyte model systems. In: Knight C, Perroud PF, Cove DJ (eds.) *The Moss Physcomitrella*, in press. Blackwell Publishing, London, pp 16–41
- Medina J, Rodriguez-Franco M, Penalosa A, Carrascosa MJ, Neuhaus G, Salinas J (2005) *Arabidopsis* mutants deregulated in RCI2A expression reveal new signaling pathways in abiotic stress responses. *Plant J* 42:586–597
- Meinke DW, Franzmann LH, Nickle TC, Yeung EC (1994) Leafy cotyledon mutants of *Arabidopsis*. *Plant Cell* 6:1049–1064
- Melotto M, Underwood W, Koczan J, Nomura K, He SY (2006) Plant stomata function in innate immunity against bacterial invasion. *Cell* 126:969–980
- Meyer K, Leube MP, Grill E (1994) A protein phosphatase 2C involved in ABA signal transduction in *Arabidopsis thaliana*. *Science* 264:1452–1455
- Miao YC, Lv D, Wang PC, Wang XC, Chen J, Miao C, Song CP (2006) An *Arabidopsis* glutathione peroxidase functions as both a redox transducer and a scavenger in abscisic acid and drought stress responses. *Plant Cell* 18:2749–2766
- Millar AA, Jacobsen JV, Ross JJ, Helliwell CA, Poole AT, Scofield G, Reid JB, Gubler F (2006) Seed dormancy and ABA metabolism in *Arabidopsis* and barley: the role of ABA 8'-hydroxylase. *Plant J* 45:942–954
- Miller G, Shulaev V, Mittler R (2008) Reactive oxygen signaling and abiotic stress. *Physiol Plantarum* 133:481–489
- Minami A, Nagao M, Arakawa K, Fujikawa S, Takezawa D (2003) Abscisic acid-induced freezing tolerance in the moss *Physcomitrella patens* is accompanied by increased expression of stress-related genes. *J Plant Physiol* 160:475–483
- Minami A, Nagao M, Ikegami K, Koshihara T, Arakawa K, Fujikawa S, Takezawa D (2005) Cold acclimation in bryophytes: low-temperature-induced freezing tolerance in *Physcomitrella patens* is associated with increases in expression levels of stress-related genes but not with increase in level of endogenous abscisic acid. *Planta* 220:414–423
- Mishra G, Zhang W, Deng F, Zhao J, Wang X (2006) A bifurcating pathway directs abscisic acid effects on stomatal closure and opening in *Arabidopsis*. *Science* 312:264–266
- Mittler R, Vanderauwera S, Gollery M, Van Breusegem F (2004) Reactive oxygen gene network of plants. *Trends Plant Sci* 9:490–498
- Miura K, Jin JB, Hasegawa PM (2007) Sumoylation, a post-translational regulatory-process in plants. *Curr Opin Plant Biol* 10:495–502
- Mochizuki N, Brusslan JA, Larkin R, Nagatani A, Chory J (2001) *Arabidopsis genomes uncoupled 5 (gun5)* mutant reveals the involvement of Mg-chelatase H subunit in plastid-to-nucleus signal transduction. *Proc Nat Acad Sci USA* 98:2053–2058
- Moes D, Himmelbach A, Korte A, Haberer G, Grill E (2008) Nuclear localization of the mutant protein phosphatase *abi1* is required for insensitivity towards ABA responses in *Arabidopsis*. *Plant J* 54:806–819
- Moon H, Lee B, Choi G, Shin D, Prasad DT, Lee O, Kwak SS, Kim DH, Nam J, Bahk J, Hong JC, Lee SY, Cho MJ,

- Lim CO, Yun DJ (2003) NDP kinase 2 interacts with two oxidative stress-activated MAPKs to regulate cellular redox state and enhances multiple stress tolerance in transgenic plants. *Proc Nat Acad Sci USA* 100:358–363
- Mullen JL, Weinig C, Hangarter RP (2006) Shade avoidance and the regulation of leaf inclination in *Arabidopsis*. *Plant Cell Environ* 29:1099–1106
- Müller AH, Hansson M (2009) The barley magnesium chelatase 150-kD subunit is not an abscisic acid receptor. *Plant Physiol* 150:157–166
- Murata Y, Pei ZM, Mori IC, Schroeder J (2001) Abscisic acid activation of plasma membrane  $Ca^{2+}$  channels in guard cells requires cytosolic NAD(P)H and is differentially disrupted upstream and downstream of reactive oxygen species production in *abi1-1* and *abi2-1* protein phosphatase 2C mutants. *Plant Cell* 13:2513–2523
- Mustilli AC, Merlot S, Vavasseur A, Fenzi F, Giraudat J (2002) *Arabidopsis* OST1 protein kinase mediates the regulation of stomatal aperture by abscisic acid and acts upstream of reactive oxygen species production. *Plant Cell* 14:3089–3099
- Naested H, Holm A, Jenkins T, Nielsen HB, Harris CA, Beale MH, Andersen M, Mant A, Scheller H, Camara B, Mattsson O, Mundy J (2004) *Arabidopsis* VARIEGATED 3 encodes a chloroplast targeted, zinc-finger protein required for chloroplast and palisade cell development. *J Cell Sci* 117:4807–4818
- Nagamune K, Hicks LM, Fux B, Brossier F, Chini EN, Sibley LD (2008) Abscisic acid controls calcium-dependent egress and development in *Toxoplasma gondii*. *Nature* 451:207–211
- Nagao M, Matsui K, Uemura M (2008) *Klebsormidium flacidum*, a charophycean green alga, exhibits cold acclimation that is closely associated with compatible solute accumulation and ultrastructural changes. *Plant Cell Environ* 31:872–885
- Nagpal P, Walker L, Young J, Sonawala A, Timpte C, Estelle M, Reed J (2000) *AXR2* encodes a member of the Aux/IAA protein family. *Plant Physiol* 123:563–573
- Nakamura A, Nakajima N, Goda H, Shimada Y, Hayashi K, Nozaki H, Asami T, Yoshida S, Fujioka S (2006) *Arabidopsis* Aux/IAA genes are involved in brassinosteroid-mediated growth responses in a manner dependent on organ type. *Plant J* 45:193–205
- Nambara E, Marion-Poll A (2005) Abscisic acid biosynthesis and catabolism. *Ann Rev Plant Biol* 56:165–185
- Nanjo T, Futamura N, Nishiguchi M, Igasaki T, Shinozaki K, Shinohara K (2004) Characterization of full-length enriched expressed sequence tags of stress-treated poplar leaves. *Plant Cell Physiol* 45:1738–1748
- Negi S, Ivanchenko MG, Muday GK (2008) Ethylene regulates lateral root formation and auxin transport in *Arabidopsis thaliana*. *Plant J* 55:175–187
- Neill SJ, Horgan R, Parry AD (1986) The carotenoid and abscisic acid content of viviparous kernels and seedlings of *Zea mays* L. *Planta* 169:87–96
- Neill S, Barros R, Bright J, Desikan R, Hancock J, Harrison J, Morris P, Ribeiro D, Wilson I (2008) Nitric oxide, stomatal closure and abiotic stress. *J Exp Bot* 59:165–176
- Németh K, Salchert K, Putnoky P, Bhalerao R, Koncz-Kálmán Z, Stankovic-Stangeland B, Bakó L, Mathur J, Okrészl L, Stabel S, Geigenberger P, Stitt M, Rédei GP, Schell J, Koncz C (1998) Pleiotropic control of glucose and hormone responses by PRL1, a nuclear WD protein, in *Arabidopsis*. *Genes Dev* 12:3059–3073
- Nishimura N, Yoshida T, Kitahata N, Asami T, Shinozaki K, Hirayama T (2007) ABA HYPERSENSITIVE GERMINATION1 encodes a protein phosphatase 2C, an essential component of abscisic acid signaling in *Arabidopsis* seed. *Plant J* 50:935–949
- Niu X, Helentjaris T, Bate NJ (2002) Maize ABI4 binds coupling element1 in abscisic acid and sugar response genes. *Plant Cell* 14:2565–2575
- Niyogi KK, Grossman AR, Björkman O (1998) *Arabidopsis* mutants define a central role for the xanthophyll cycle in the regulation of photosynthetic energy conversion. *Plant Cell* 10:1121–1134
- Nomura H, Komori T, Kobori M, Nakahira Y, Shiina T (2008) Evidence for chloroplast control of external  $Ca^{2+}$ -induced cytosolic  $Ca^{2+}$  transients and stomatal closure. *Plant J* 53:988–998
- North HM, De Almeida A, Boutin JP, Frey A, To A, Botran L, Sotta B, Marion-Poll A (2007) The *Arabidopsis* ABA-deficient mutant *aba4* demonstrates that the major route for stress-induced ABA accumulation is via neoxanthin isomers. *Plant J* 50:810–824
- Nyangulu JM, Nelson KM, Rose PA, Gai YZ, Loewen M, Lougheed B, Quail JW, Cutler AJ, Abrams SR (2006) Synthesis and biological activity of tetralone abscisic acid analogues. *Org Biomol Chem* 4:1400–1412
- Ofir M, Kerem D (1982) The effects of temperature and photoperiod on the onset of summer dormancy in *Poa bulbosa* L. *Ann Bot* 50:259–264
- Ofir M, Kigel J (1998) Abscisic acid involvement in the induction of summer-dormancy in *Poa bulbosa*, a grass geophyte. *Physiol Plantarum* 102:163–170
- Ofir M, Kigel J (2007) Regulation of summer dormancy by water deficit and ABA in *Poa bulbosa* ecotypes. *Ann Bot (London)* 99:293–299
- Oh E, Yamaguchi S, Hu JH, Yusuke J, Jung B, Paik I, Lee HS, Sun TP, Kamiya Y, Choi G (2007) PIL5, a phytochrome-interacting bHLH protein, regulates gibberellin responsiveness by binding directly to the GAI and RGA promoters in *Arabidopsis* seeds. *Plant Cell* 19:1192–1208
- Ohnishi N, Himi E, Yamasaki Y, Noda K (2008) Differential expression of three ABA-insensitive five binding protein (AFP)-like genes in wheat. *Gene Genet Syst* 83:167–177
- Ohta M, Guo Y, Halfter U, Zhu JK (2003) A novel domain in the protein kinase SOS2 mediates interaction with the protein phosphatase 2C ABI2. *Proc Nat Acad Sci USA* 100:11771–11776



- Okamoto M, Kuwahara A, Seo M, Kushiro T, Asami T, Hirai N, Kamiya Y, Koshihara T, Nambara E (2006) CYP707A1 and CYP707A2, which encode abscisic acid 8'-hydroxylases, are indispensable for proper control of seed dormancy and germination in *Arabidopsis*. *Plant Physiol* 141:97–107
- Oliver SN, Dennis ES, Dolferus R (2007) ABA regulates apoplastic sugar transport and is a potential signal for cold-induced pollen sterility in rice. *Plant Cell Physiol* 48:1319–1330
- Ortiz-Masia D, Perez-Amador MA, Carbonell J, Marcote MJ (2007) Diverse stress signals activate the C1 subgroup MAP kinases of *Arabidopsis*. *FEBS Lett* 581:1834–1840
- Osakabe Y, Maruyama K, Seki M, Satou M, Shinozaki K, Yamaguchi-Shinozaki K (2005) Leucine-rich repeat receptor-like kinase1 is a key membrane-bound regulator of abscisic acid early signaling in *Arabidopsis*. *Plant Cell* 17:1105–1119
- Page Le, de Givry MT, Bidard JN, Rouvier E, Bulard C, Lazdunski M (1986) Presence of abscisic acid, a phytohormone, in mammalian brain. *Proc Nat Acad Sci USA* 83:1155–1158
- Pandey S, Chen JG, Jones AM, Assmann SM (2006) G-protein complex mutants are hypersensitive to abscisic acid regulation of germination and postgermination development. *Plant Physiol* 141:243–256
- Pandey S, Nelson DC, Assmann SM (2009) Two novel GPCR-type G proteins are abscisic acid receptors in *Arabidopsis*. *Cell* 136:136–148
- Pandey A, Chakraborty S, Datta A, Chakraborty N (2008) Proteomics approach to identify dehydration responsive nuclear proteins from chickpea (*Cicer arietinum* L.). *Mol Cell Proteomics* 7:88–107
- Papdi C, Abraham E, Joseph MP, Popescu C, Koncz C, Szabados L (2008) Functional identification of *Arabidopsis* stress regulatory genes using the controlled cDNA over-expression system. *Plant Physiol* 147:528–542
- Papp I, Mur LA, Dalmadi A, Dulai S, Koncz C (2004) A mutation in the Cap Binding Protein 20 gene confers drought tolerance to *Arabidopsis*. *Plant Mol Biol* 55:679–686
- Parcy F, Valon C, Kohara A, Misera S, Giraudat J (1997) The *ABSCISIC ACID-INSENSITIVE3*, *FUSCA3*, and *LEAFY COTYLEDON1* loci act in concert to control multiple aspects of *Arabidopsis* seed development. *Plant Cell* 9:1265–1277
- Park S-Y, Fung P, Nishimura N, Jensen DR, Fujii H, Zhao Y, Lumba S, Santiago J, Rodrigues A, Chow TF, Alfred SE, Bonetta D, Finkelstein R, Provart NJ, Desveaux D, Rodriguez PL, McCourt P, Zhu JK, Schroeder JI, Volkman BF, Cutler SR (2009) Abscisic acid inhibits type 2C protein phosphatases via the PYR/PYL family of START proteins. *Science* 324:1068–1071
- Paul AL, Schuerger AC, Popp MP, Richards JT, Manak MS, Ferl RJ (2004) Hypobaric biology: *Arabidopsis* gene expression at low atmospheric pressure. *Plant Physiol* 134:215–223
- Pei Z, Murata Y, Benning G, Thomine S, Klusener B, Allen G, Grill E, Schroeder J (2000) Calcium channels activated by hydrogen peroxide mediate abscisic acid signalling in guard cells. *Nature* 406:731–734
- Penfield S (2008) Temperature perception and signal transduction in plants. *New Phytol* 179:615–628
- Pernas M, Garcia-Casado G, Rojo E, Solano R, Sanchez-Serrano JJ (2007) A protein phosphatase 2A catalytic subunit is a negative regulator of abscisic acid signalling. *Plant J* 51:763–778
- Phillips JR, Dalmay T, Bartels D (2007) The role of small RNAs in abiotic stress. *FEBS Lett* 581:3592–3597
- Pontier D, Albrieux C, Joyard J, Lagrange T, Block MA (2007) Knock-out of the magnesium protoporphyrin IX methyltransferase gene in *Arabidopsis* - Effects on chloroplast development and on chloroplast-to-nucleus signaling. *J Biol Chem* 282:2297–2304
- Porch TG, Tseung CW, Schmelz EA, Settles AM (2006) The maize *VIVIPAROUS10/VIVIPAROUS13* locus encodes the *CNX1* gene required for molybdenum cofactor biosynthesis. *Plant J* 45:250–263
- Pourtau N, Mares M, Purdy S, Quentin N, Ruel A, Wingler A (2004) Interactions of abscisic acid and sugar signalling in the regulation of leaf senescence. *Planta* 219:765–772
- Priest DM, Ambrose SJ, Vaistij FE, Elias L, Higgins GS, Ross ARS, Abrams SR, Bowles DJ (2006) Use of the glucosyltransferase UGT71B6 to disturb abscisic acid homeostasis in *Arabidopsis thaliana*. *Plant J* 46:492–502
- Prieto-Dapena P, Castano R, Almoguera C, Jordano J (2008) The ectopic overexpression of a seed-specific transcription factor, HaHSFA9, confers tolerance to severe dehydration in vegetative organs. *Plant J* 54:1004–1014
- Puce S, Basile G, Bavestrello G, Bruzzone S, Cerrano C, Giovine M, Arillo A, Zocchi E (2004) Abscisic acid signaling through cyclic ADP-ribose in hydroid regeneration. *J Biol Chem* 279:39783–39788
- Qiu JL, Zhou L, Yun BW, Nielsen HB, Fiil BK, Petersen K, Mackinlay J, Loake GJ, Mundy J, Morris PC (2008) *Arabidopsis* mitogen-activated protein kinase kinases MKK1 and MKK2 have overlapping functions in defense signaling mediated by MEKK1, MPK4, and MKS1. *Plant Physiol* 148:212–222
- Quatrano RS, McDaniel SF, Khandelwal A, Perroud PF, Cove DJ (2007) *Physcomitrella patens*: mosses enter the genomic age. *Curr Opin Plant Biol* 10:182–189
- Quintero FJ, Garcíadeblas B, Rodríguez-Navarro A (1996) The *SAL1* gene of *Arabidopsis*, encoding an enzyme with 3, 2, 5-bisphosphate nucleotidase and inositol polyphosphate 1-phosphatase activities, increases salt tolerance in yeast. *Plant Cell* 8:529–537
- Ramon M, Rolland F, Thevelein JM, Van Dijck P, Leyman B (2007) ABI4 mediates the effects of exogenous trehalose on *Arabidopsis* growth and starch breakdown. *Plant Mol Biol* 63:195–206
- Raskin I, Ladyman JAR (1988) Isolation and characterization of a barley mutant with abscisic-acid insensitive stomata. *Planta* 173:73–78



- Razem FA, Hill RD (2007) Hydrogen peroxide affects abscisic acid binding to ABAP1 in barley aleurones. *Biochem Cell Biol* 85:628–637
- Razem FA, Luo M, Liu JH, Abrams SR, Hill RD (2004) Purification and characterization of a barley aleurone abscisic acid-binding protein. *J Biol Chem* 279:9922–9929
- Razem FA, El-Kereamy A, Abrams SR, Hill RD (2006) The RNA-binding protein FCA is an abscisic acid receptor. *Nature* 439:290–294
- Razem FA, El-Kereamy A, Abrams SR, Hill RD (2008) The RNA-binding protein FCA is an abscisic acid receptor (Retraction). *Nature* 456:824. doi:10.1038/nature07645
- Ren J, Dai WR, Xuan ZY, Yao YN, Korpelainen H, Li CY (2007) The effect of drought and enhanced UV-B radiation on the growth and physiological traits of two contrasting poplar species. *Forest Ecol Manag* 239:112–119
- Rensing SA, Lang D, Zimmer AD, Terry A, Salamov A, Shapiro H, Nishiyama T, Perroud PF, Lindquist EA, Kamisugi Y, Tanahashi T, Sakakibara K, Fujita T, Oishi K, Shin-I T, Kuroki Y, Toyoda A, Suzuki Y, Hashimoto S, Yamaguchi K, Sugano S, Kohara Y, Fujiyama A, Anterola A, Aoki S, Ashton N, Barbazuk WB, Barker E, Bennetzen JL, Blankenship R, Cho SH, Dutcher SK, Estelle M, Fawcett JA, Gundlach H, Hanada K, Heyl A, Hicks KA, Hughes J, Lohr M, Mayer K, Melkozernov A, Murata T, Nelson DR, Pils B, Prigge M, Reiss B, Renner T, Rombauts S, Rushon PJ, Sanderfoot A, Schween G, Shiu SH, Stueber K, Theodoulou FL, Tu H, Van de Peer Y, Verrier PJ, Waters E, Wood A, Yang LX, Cove D, Cuming AC, Hasebe M, Lucas S, Mishler BD, Reski R, Grigoriev IV, Quatrano RS, Boore JL (2008) The *Physcomitrella* genome reveals evolutionary insights into the conquest of land by plants. *Science* 319:64–69
- Reyes D, Rodriguez D, Gonzalez-Garcia MP, Lorenzo O, Nicolas G, Garcia-Martinez JL, Nicolas C (2006) Overexpression of a protein phosphatase 2C from beech seeds in *Arabidopsis* shows phenotypes related to abscisic acid responses and gibberellin biosynthesis. *Plant Physiol* 141:1414–1424
- Reynolds T, Thompson PA (1971) Characterisation of the high temperature inhibition of germination of lettuce (*Lactuca sativa*). *Physiol Plantarum* 24:544–547
- Risk JM, Macknight RC and Day CL (2008) FCA does not bind abscisic acid. *Nature* 456: E5–E6 (11 December 2008). doi:10.1038/nature07646
- Risk JM, Day CL, Macknight RC (2009) Reevaluation of abscisic acid-binding assays shows that G-Protein-Coupled Receptor2 does not bind abscisic acid. *Plant Physiol* 150:6–11
- Rivero RM, Kojima M, Gepstein A, Sakakibara H, Mittler R, Gepstein S, Blumwald E (2007) Delayed leaf senescence induces extreme drought tolerance in a flowering plant. *Proc Nat Acad Sci USA* 104:19631–19636
- Robertson DS (1955) The genetics of vivipary in maize. *Genetics* 40:745–760
- Robertson AJ, Ishikawa M, Gusta LV, MacKenzie SL (1994) Abscisic acid-induced heat tolerance in *Bromus inermis* Leyss cell-suspension cultures: Heat-stable, abscisic acid-responsive polypeptides in combination with sucrose confer enhanced thermostability. *Plant Physiol* 105:181–190
- Rock CD (2000) Pathways to abscisic acid-regulated gene expression. *New Phytol* 148:357–396
- Rodriguez P, Benning G, Grill E (1998) ABI2, a second protein phosphatase 2C involved in abscisic acid signal transduction in *Arabidopsis*. *FEBS Lett* 421:185–190
- Rook F, Corke F, Card R, Munz G, Smith C, Bevan MW (2001) Impaired sucrose-induction mutants reveal the modulation of sugar-induced starch biosynthetic gene expression by abscisic acid signalling. *Plant J* 26:421–433
- Rook F, Corke F, Baier M, Holman R, May AG, Bevan MW (2006a) Impaired sucrose induction1 encodes a conserved plant-specific protein that couples carbohydrate availability to gene expression and plant growth. *Plant J* 46:1045–1058
- Rook F, Hadingham SA, Li Y, Bevan MW (2006b) Sugar and ABA response pathways and the control of gene expression. *Plant Cell Environ* 29:426–434
- Running MP, Lavy M, Sternberg H, Galichet A, Gruissem W, Hake S, Ori N, Yalovsky S (2004) Enlarged meristems and delayed growth in *p1p* mutants result from lack of CaaX prenyltransferases. *Proc Nat Acad Sci USA* 101:7815–7820
- Saez A, Apostolova N, Gonzalez-Guzman M, Gonzalez-Garcia MP, Nicolas C, Lorenzo O, Rodriguez PL (2004) Gain-of-function and loss-of-function phenotypes of the protein phosphatase 2C HAB1 reveal its role as a negative regulator of abscisic acid signalling. *Plant J* 37:354–369
- Saez A, Robert N, Maktabi MH, Schroeder JI, Serrano R, Rodriguez PL (2006) Enhancement of abscisic acid sensitivity and reduction of water consumption in *Arabidopsis* by combined inactivation of the protein phosphatases type 2C ABI1 and HAB1. *Plant Physiol* 141:1389–1399
- Saez A, Rodrigues A, Santiago J, Rubio S, Rodriguez PL (2008) HAB1-SWI3B interaction reveals a link between abscisic acid signaling and putative SWI/SNF chromatin-remodeling complexes in *Arabidopsis*. *Plant Cell* 20:2972–2988
- Saika H, Okamoto M, Miyoshi K, Kushiro T, Shinoda S, Jikumaru Y, Fujimoto M, Arikawa T, Takahashi H, Ando M, Arimura S, Miyao A, Hirochika H, Kamiya Y, Tsutsumi N, Nambara E, Nakazono M (2007) Ethylene promotes submergence-induced expression of *OsABA8ox1*, a gene that encodes ABA 8-hydroxylase in rice. *Plant Cell Physiol* 48:287–298
- Saito S, Hirai N, Matsumoto C, Ohigashi H, Ohta D, Sakata K, Mizutani M (2004) *Arabidopsis* CYP707As encode (+)-abscisic acid 8-hydroxylase, a key enzyme in the oxidative catabolism of abscisic acid. *Plant Physiol* 134:1439–1449
- Saito S, Okamoto M, Kushiro T, Koshiba T, Kamiya Y, Hirai N, Todoroki Y, Sakata K, Nambara E, Mizutani M (2006) A plant growth retardant, uniconazole, is a potent inhibitor of ABA catabolism in *Arabidopsis*. *Biosci Biotechnol Biochem* 70:1731–1739

- Samuel MA, Mudgil Y, Salt JN, Delmas F, Ramachandran S, Chilelli A, Goring DR (2008) Interactions between the S-domain receptor kinases and AtPUB-ARM E3 ubiquitin ligases suggest a conserved signaling pathway in *Arabidopsis*. *Plant Physiol* 147:2084–2095
- Sawa S, Kinoshita A, Nakanomyo I, Fukuda H (2006) CLV3/ESR-related (CLE) peptides as intercellular signaling molecules in plants. *Chem Rec* 6:303–310
- Sawada Y, Aoki M, Nakaminami K, Mitsuhashi W, Tate-matsu K, Kushiro T, Koshiba T, Kamiya Y, Inoue Y, Nambara E, Toyomasu T (2008) Phytochrome- and gibberellin-mediated regulation of abscisic acid metabolism during germination of photoblastic lettuce seeds. *Plant Physiol* 146:1386–1396
- Schallau A, Kakhovskaya I, Tewes A, Czihal A, Tiedemann J, Mohr M, Grosse N, Manteuffel R, Baumlein H (2008) Phylogenetic footprints in fern spore- and seed-specific gene promoters. *Plant J* 53:414–424
- Schultz T, Quatrano RS (1997) Evidence for surface perception of abscisic acid by rice suspension cells as assayed by *Em* gene expression. *Plant Sci* 130:63–71
- Schwartz SH, Tan BC, Gage DA, Zeevaart JAD, McCarty DR (1997) Specific oxidative cleavage of carotenoids by VP14 of maize. *Science* 276:1872–1874
- Schwartz SH, Qin XQ, Loewen MC (2004) The biochemical characterization of two carotenoid cleavage enzymes from *Arabidopsis* indicates that a carotenoid-derived compound inhibits lateral branching. *J Biol Chem* 279:46940–46945
- Schweighofer A, Hirt H, Meskiene I (2004) Plant PP2C phosphatases: emerging functions in stress signaling. *Trends Plant Sci* 9:236–243
- Seki M, Ishida J, Narusaka M, Fujita M, Nanjo T, Umezawa T, Kamiya A, Nakajima M, Enju A, Sakurai T, Satou M, Akiyama K, Yamaguchi-Shinozaki K, Carninci P, Kawai J, Hayashizaki Y, Shinozaki K (2002a) Monitoring the expression pattern of around 7,000 *Arabidopsis* genes under ABA treatments using a full-length cDNA microarray. *Funct Integr Genom* 2:282–291
- Seki M, Narusaka M, Ishida J, Nanjo T, Fujita M, Oono Y, Kamiya A, Nakajima M, Enju A, Sakurai T, Satou M, Akiyama K, Tajiri T, Yamaguchi-Shinozaki K, Carninci P, Kawai J, Hayashizaki Y, Shinozaki K (2002b) Monitoring the expression profiles of 7,000 *Arabidopsis* genes under drought, cold and high-salinity stresses using a full-length cDNA microarray. *Plant J* 31:279–292
- Seki M, Satou M, Sakurai T, Akiyama K, Iida K, Ishida J, Nakajima M, Enju A, Narusaka M, Fujita M, Oono Y, Kamei A, Yamaguchi-Shinozaki K, Shinozaki K (2004) RIKEN *Arabidopsis* full-length (RAFL) cDNA and its applications for expression profiling under abiotic stress conditions. *J Exp Bot* 55:213–223
- Seo M, Peeters AJ, Koiwai H, Oritani T, Marion-Poll A, Zeevaart JAD, Koornneef M, Kamiya Y, Koshiba T (2000) The *Arabidopsis aldehyde oxidase 3 (AAO3)* gene product catalyzes the final step in abscisic acid biosynthesis in leaves. *Proc Natl Acad Sci USA* 97:12908–12913
- Seo M, Hanada A, Kuwahara A, Endo A, Okamoto M, Yamauchi Y, North H, Marion-Poll A, Sun TP, Koshiba T, Kamiya Y, Yamaguchi S, Nambara E (2006) Regulation of hormone metabolism in *Arabidopsis* seeds: phytochrome regulation of abscisic acid metabolism and abscisic acid regulation of gibberellin metabolism. *Plant J* 48:354–366
- Shen Q, Ho TH (1995) Functional dissection of an abscisic acid (ABA)-inducible gene reveals two independent ABA-responsive complexes each containing a G-box and a novel *cis*-acting element. *Plant Cell* 7:295–307
- Shen YY, Wang XF, Wu FQ, Du SY, Cao Z, Shang Y, Wang XL, Peng CC, Yu XC, Zhu SY, Fan RC, Xu YH, Zhang DP (2006) The Mg-chelatase H subunit is an abscisic acid receptor. *Nature* 443:823–826
- Shinozaki K, Yamaguchi-Shinozaki K (2000) Molecular responses to dehydration and low temperature: differences and cross-talk between two stress signaling pathways. *Curr Opin Plant Biol* 3:217–223
- Siewers V, Kokkelink L, Smedsgaard J, Tudzynski P (2006) Identification of an abscisic acid gene cluster in the grey mold *Botrytis cinerea*. *Appl Environ Microbiol* 72:4619–4626
- Smith TR, Clark AJ, Clarkson GJ, Taylor PC, Marsh A (2006) Concise enantioselective synthesis of abscisic acid and a new analogue. *Org Biomol Chem* 4:4186–4192
- Song L, Han MH, Lesicka J, Fedoroff N (2007) *Arabidopsis* primary microRNA processing proteins HYL1 and DCL1 define a nuclear body distinct from the Cajal body. *Proc Natl Acad Sci USA* 104:5437–5442
- Staswick P, Su W, Howell S (1992) Methyl jasmonate inhibition of root growth and induction of a leaf protein are decreased in an *Arabidopsis thaliana* mutant. *Proc Natl Acad Sci USA* 89:6837–6840
- Steber C, McCourt P (2001) A role for brassinosteroids in germination in *Arabidopsis*. *Plant Physiol* 125:763–769
- Stockinger EJ, Gilmour SJ, Thomashow MF (1997) *Arabidopsis thaliana* CBF1 encodes an AP2 domain-containing transcriptional activator that binds to the C-repeat/DRE, a *cis*-acting DNA regulatory element that stimulates transcription in response to low temperature and water deficit. *Proc Natl Acad Sci USA* 94:1035–1040
- Stone SL, Callis J (2007) Ubiquitin ligases mediate growth and development by promoting protein death. *Curr Opin Plant Biol* 10:624–632
- Strader LC, Monroe-Augustus M, Bartel B (2008) The IBR5 phosphatase promotes *Arabidopsis* auxin responses through a novel mechanism distinct from TIR1-mediated repressor degradation. *BMC Plant Biology* 8: doi: 4110.1186/1471-2229-4118-4141
- Sturaro M, Vernieri P, Castiglioni P, Binelli G, Gavazzi G (1996) The *rea (red embryonic axis)* phenotype describes a new mutation affecting the response of maize embryos to abscisic acid and osmotic stress. *J Exp Bot* 47:755–762
- Subramanian S, Rajagopal B, Rock CD (2002) *Harlequin (hlq)* and short blue root (*sbr*), two *Arabidopsis* mutants that ectopically express an abscisic acid- and auxin-inducible

- transgenic carrot promoter and have pleiotropic effects on morphogenesis. *Plant Mol Biol* 49:93–105
- Sun S, Yu JP, Chen F, Zhao TJ, Fang XH, Li YQ, Sui SF (2008) TINY, a dehydration-responsive element (DRE)-binding protein-like transcription factor connecting the DRE- and ethylene-responsive element-mediated signaling pathways in *Arabidopsis*. *J Biol Chem* 283:6261–6271
- Suzuki M, McCarty DR (2008) Functional symmetry of the B3 network controlling seed development. *Curr Opin Plant Biol* 11:548–553
- Suzuki M, Settles AM, Tseung CW, Li QB, Latshaw S, Wu S, Porch TG, Schmelz EA, James MG, McCarty DR (2006) The maize *VIVIPAROUS15* locus encodes the molybdopterin synthase small subunit. *Plant J* 45:264–274
- Suzuki M, Latshaw S, Sato Y, Settles AM, Koch KE, Hannah LC, Kojima M, Sakakibara H, McCarty DR (2008a) The maize *VIVIPAROUS8* locus, encoding a putative ALTERED MERISTEM PROGRAM1-like peptidase, regulates abscisic acid accumulation and coordinates embryo and endosperm development. *Plant Physiol* 146:1193–1206
- Tahtiharju S, Palva T (2001) Antisense inhibition of protein phosphatase 2C accelerates cold acclimation in *Arabidopsis thaliana*. *Plant J* 26:461–470
- Takahashi S, Katagiri T, Hirayama T, Yamaguchi-Shinozaki K, Shinozaki K (2001) Hyperosmotic stress induces a rapid and transient increase in inositol 1, 4, 5-trisphosphate independent of abscisic acid in *Arabidopsis* cell culture. *Plant Cell Physiol* 42:214–222
- Tamura N, Yoshida T, Tanaka A, Sasaki R, Bando A, Toh S, Lepiniec L, Kawakami N (2006) Isolation and characterization of high temperature-resistant germination mutants of *Arabidopsis thaliana*. *Plant Cell Physiol* 47:1081–1094
- Tang RH, Han S, Zheng H, Cook CW, Choi CS, Woerner TE, Jackson RB, Pei ZM (2007) Coupling diurnal cytosolic Ca<sup>2+</sup> oscillations to the CAS-IP3 pathway in *Arabidopsis*. *Science* 315:1423–1426
- Tardif G, Kane NA, Adam H, Labrie L, Major G, Gulick P, Sarhan F, Laliberté JF (2007) Interaction network of proteins associated with abiotic stress response and development in wheat. *Plant Mol Biol* 63:70–718
- Teaster ND, Motes CM, Tang YH, Wiant WC, Cotter MQ, Wang YS, Kilaru A, Venables BJ, Hasenstein KH, Gonzalez G, Blancaflor EB, Chapman KD (2007) N-acyl ethanolamine metabolism interacts with abscisic acid signaling in *Arabidopsis thaliana* seedlings. *Plant Cell* 19:2454–2469
- Technau U, Rudd S, Maxwell P, Gordon PMK, Saina M, Grasso LC, Hayward DC, Sensen CW, Saint R, Holstein TW, Ball EE, Miller DJ (2005) Maintenance of ancestral complexity and non-metazoan genes in two basal cnidarians. *Trends Genet* 21:633–639
- Terumoto I (1959) Frost and drought injury in lake-balls. *Low Temp Sci* B17:1–7
- Testerink C, Munnik T (2005) Phosphatidic acid: a multifunctional stress signaling lipid in plants. *Trends Plant Sci* 10:368–375
- Thomma BP, Penninckx IA, Broekaert WF, Cammue BP (2001) The complexity of disease signaling in *Arabidopsis*. *Curr Opin Immun* 13:63–68
- Thompson AJ, Andrews J, Mulholland BJ, McKee JMT, Hilton HW, Black CR, Taylor IB (2007) Overproduction of abscisic acid in tomato increases transpiration efficiency and root hydraulic conductivity and influences leaf expansion. *Plant Physiol* 143:1905–1917
- Toh S, Imamura A, Watanabe A, Nakabayashi K, Okamoto M, Jikumaru Y, Hanada A, Aso Y, Ishiyama K, Tamura N, Iuchi S, Kobayashi M, Yamaguchi S, Kamiya Y, Nambara E, Kawakami N (2008) High temperature-induced abscisic acid biosynthesis and its role in the inhibition of gibberellin action in *Arabidopsis* seeds. *Plant Physiol* 146:1368–1385
- Ton J, Mauch-Mani B (2004) Beta-amino-butyric acid-induced resistance against necrotrophic pathogens is based on ABA-dependent priming for callose. *Plant J* 38:119–130
- Ton J, Jakab G, Toquin V, Flors V, Iavicoli A, Maeder MN, Metraux JP, Mauch-Mani B (2005) Dissecting the beta-aminobutyric acid-induced priming phenomenon in *Arabidopsis*. *Plant Cell* 17:987–999
- Tran LSP, Nakashima K, Sakuma Y, Osakabe Y, Qin F, Simpson SD, Maruyama K, Fujita Y, Shinozaki K, Yamaguchi-Shinozaki K (2007) Co-expression of the stress-inducible zinc finger homeodomain ZFHD1 and NAC transcription factors enhances expression of the *ERD1* gene in *Arabidopsis*. *Plant J* 49:46–63
- Trusov Y, Rookes JE, Tilbrook K, Chakravorty D, Mason MG, Anderson D, Chen JG, Jones AM, Botella JR (2007) Heterotrimeric G protein gamma subunits provide functional selectivity in G beta gamma dimer signaling in *Arabidopsis*. *Plant Cell* 19:1235–1250
- Tzvetkova-Chevolleau T, Franck F, Alawady AE, Dall'Osto L, Carriere F, Bassi R, Grimm B, Nussaume L, Havaux M (2007) The light stress-induced protein ELIP2 is a regulator of chlorophyll synthesis in *Arabidopsis thaliana*. *Plant J* 50:795–809
- Ueno K, Yoneyama H, Mizutani M, Hirai N, Todoroki Y (2007) Asymmetrical ligand binding by abscisic acid 8-hydroxylase. *Bioorg Med Chem* 15:6311–6322
- Umezawa T, Okamoto M, Kushiro T, Nambara E, Oono Y, Seki M, Kobayashi M, Koshihara T, Kamiya Y, Shinozaki K (2006) CYP707A3, a major ABA 8'-hydroxylase involved in dehydration and rehydration response in *Arabidopsis thaliana*. *Plant J* 46:171–182
- Uno Y, Furihata T, Abe H, Yoshida R, Shinozaki K, Yamaguchi-Shinozaki K (2000) *Arabidopsis* basic leucine zipper transcription factors involved in an abscisic acid-dependent signal transduction pathway under drought and high-salinity conditions. *Proc Natl Acad Sci USA* 97:11632–11637
- van den Burg HA, Tsitsigiannis DI, Rowland O, Lo J, Rallapalli G, MacLean D, Takken FLW, Jones JDG (2008) The F-box protein ACRE189/ACIF1 regulates cell death and defense responses activated during pathogen recognition in tobacco and tomato. *Plant Cell* 20:697–719

- van Hengel AJ, Barber C, Roberts K (2004) The expression patterns of arabinogalactan-protein AtAGP30 and GLABRA2 reveal a role for abscisic acid in the early stages of root epidermal patterning. *Plant J* 39:70–83
- Verslues PE, Zhu JK (2007) New developments in abscisic acid perception and metabolism. *Curr Opin Plant Biol* 10:447–452
- Vlad F, Turk BE, Peynot P, Leung J, Merlot S (2008) A versatile strategy to define the phosphorylation preferences of plant protein kinases and screen for putative substrates. *Plant J* 55:104–117
- Vranova E, Tahtiharju S, Sriprang R, Willekens H, Heino P, Palva ET, Inze D, Van Camp W (2001) The AKT3 potassium channel protein interacts with the AtPP2CA protein phosphatase 2C. *J Exp Bot* 52:181–182
- Walley JW, Coughlan S, Hudson ME, Covington MF, Kaspi R, Banu G, Harmer SL, Dehesh K (2007) Mechanical stress induces biotic and abiotic stress responses via a novel cis-element. *PLoS Genet* 3:1800–1812
- Wang XF, Zhang DP (2008) Abscisic acid receptors: Multiple signal-perception sites. *Ann Bot* 101:311–317
- Wang Y, Ying JF, Kuzma M, Chalifoux M, Sample A, McArthur C, Uchacz T, Sarvas C, Wan JX, Dennis DT, McCourt P, Huang YF (2005) Molecular tailoring of farnesylation for plant drought tolerance and yield protection. *Plant J* 43:413–424
- Wang Y, Liu C, Li K, Sun F, Hu H, Li X, Zhao Y, Han C, Zhang W, Duan Y, Liu M, Li X (2007) Arabidopsis EIN2 modulates stress response through abscisic acid response pathway. *Plant Mol Biol* 64:633–644
- Wang GD, Ellendorff U, Kemp B, Mansfield JW, Forsyth A, Mitchell K, Bastas K, Liu CM, Woods-Tor A, Zipfel C, de Wit P, Jones JDG, Tor M, Thomma B (2008a) A genome-wide functional investigation into the roles of receptor-like proteins in *Arabidopsis*. *Plant Physiol* 147:503–517
- Warpeha KM, Upadhyay S, Yeh J, Adamiak J, Hawkins SI, Lapiak YR, Anderson MB, Kaufman LS (2007) The GCR1, GPA1, PRN1, NF-Y signal chain mediates both blue light and abscisic acid responses in *Arabidopsis*. *Plant Physiol* 143:1590–1600
- Welsch R, Wust F, Bar C, Al-Babili S, Beyer P (2008) A third phytoene synthase is devoted to abiotic stress-induced abscisic acid formation in rice and defines functional diversification of phytoene synthase genes. *Plant Physiol* 147:367–380
- Weston DJ, Gunter LE, Rogers A, Wullschlegel SD (2008) Connecting genes, coexpression modules and molecular signatures to environmental stress phenotypes in plants. *BMC Syst Biol* 2:16
- Wilson A, Pickett F, Turner J, Estelle M (1990) A dominant mutation in *Arabidopsis* confers resistance to auxin, ethylene and abscisic acid. *Mol Gen Genet* 222:377–383
- Wohlbach DJ, Quirino BF, Sussman MR (2008) Analysis of the *Arabidopsis* histidine kinase ATHK1 reveals a connection between vegetative osmotic stress sensing and seed maturation. *Plant Cell* 20:1101–1117
- Wollers S, Heidenreich T, Zarepour M, Zachmann D, Kraft C, Zhao YD, Mendel RR, Bittner F (2008) Binding of sulfurated molybdenum cofactor to the C-terminal domain of ABA3 from *Arabidopsis thaliana* provides insight into the mechanism of molybdenum cofactor sulfuration. *J Biol Chem* 283:9642–9650
- Xiao H, Siddiqua M, Braybrook S, Nassuth A (2006) Three grape *CBF/DREB1* genes respond to low temperature, drought and abscisic acid. *Plant Cell Environ* 29:1410–1421
- Xin Z, Browse J (1998) *eskimo1* mutants of *Arabidopsis* are constitutively freezing-tolerant. *Proc Nat Acad Sci USA* 95:7799–7804
- Xin Z, Mandaokar A, Chen J, Last RL, Browse J (2007) *Arabidopsis ESK1* encodes a novel regulator of freezing tolerance. *Plant J* 49:786–799
- Xing Y, Jia W, Zhang J (2007) AtMEK1 mediates stress-induced gene expression of *CAT1* catalase by triggering H<sub>2</sub>O<sub>2</sub> production in *Arabidopsis*. *J Exp Bot* 58:2969–2981
- Xing Y, Jia WS, Zhang JH (2008) AtMKK1 mediates ABA-induced *CAT1* expression and H<sub>2</sub>O<sub>2</sub> production via AtMPK6-coupled signaling in *Arabidopsis*. *Plant J* 54:440–451
- Xiong L, Ishitani M, Lee H, Zhu JK (2001) The *Arabidopsis LOS5/ABA3* locus encodes a molybdenum cofactor sulfurylase and modulates cold stress- and osmotic stress-responsive gene expression. *Plant Cell* 13:2063–2083
- Xiong L, Lee H, Ishitani M, Zhu JK (2002) Regulation of osmotic stress-responsive gene expression by the *LOS6/ABA1* locus in *Arabidopsis*. *J Biol Chem* 277:8588–8596
- Xiong LM, Lee H, Huang RF, Zhu JK (2004) A single amino acid substitution in the *Arabidopsis* FIERY1/HOS2 protein confers cold signaling specificity and lithium tolerance. *Plant J* 40:536–545
- Xiong LM, Wang RG, Mao GH, Koczan JM (2006) Identification of drought tolerance determinants by genetic analysis of root response to drought stress and abscisic acid. *Plant Physiol* 142:1065–1074
- Xu DQ, Huang J, Guo SQ, Yang X, Bao YM, Tang HJ, Zhang HS (2008) Over-expression of a TFIIIA-type zinc finger protein gene *ZFP252* enhances drought and salt tolerance in rice (*Oryza sativa* L.). *FEBS Lett* 582:1037–1043
- Yadav V, Mallappa C, Gangappa SN, Bhatia S, Chattopadhyay S (2005) A basic helix-loop-helix transcription factor in *Arabidopsis*, MYC2, acts as a repressor of blue light-mediated photomorphogenic growth. *Plant Cell* 17:1953–1966
- Yan CS, Shen H, Qb Li, He ZH (2006a) A novel ABA-hypersensitive mutant in *Arabidopsis* defines a genetic locus that confers tolerance to xerothermic stress. *Planta* 224:889–899
- Yang SH, Zeevaart JAD (2006) Expression of ABA 8'-hydroxylases in relation to leaf water relations and seed development in bean. *Plant J* 47:675–686
- Yasuda M, Ishikawa A, Jikumaru Y, Seki M, Umezawa T, Asami T, Maruyama-Nakashita A, Kudo T, Shinozaki K,



- Yoshida S, Nakashita H (2008) Antagonistic interaction between systemic acquired resistance and the abscisic acid-mediated abiotic stress response in *Arabidopsis*. *Plant Cell* 20:1678–1692
- Yoshida R, Hobo T, Ichimura K, Mizoguchi T, Takahashi F, Aronso J, Ecker JR, Shinozaki K (2002) ABA-activated SnRK2 protein kinase is required for dehydration stress signaling in *Arabidopsis*. *Plant Cell Physiol* 43:1473–1483
- Yoshida T, Nishimura N, Kitahata N, Kuromori T, Ito T, Asami T, Shinozaki K, Hirayama T (2006a) *ABA HYPERSENSITIVE GERMINATION3* encodes a protein phosphatase 2C (AtPP2CA) that strongly regulates abscisic acid signaling during germination among *Arabidopsis* protein phosphatase 2Cs. *Plant Physiol* 140:115–126
- Yoshida R, Umezawa T, Mizoguchi T, Takahashi S, Takahashi F, Shinozaki K (2006b) The regulatory domain of SRK2E/OST1/SnRK2.6 interacts with ABI1 and integrates abscisic acid (ABA) and osmotic stress signals controlling stomatal closure in *Arabidopsis*. *J Biol Chem* 281:5310–5318
- Yoshioka T, Endo T, Satoh S (1998) Restoration of seed germination at supraoptimal temperatures by fluridone, an inhibitor of abscisic acid biosynthesis. *Plant Cell Physiol* 39:307–312
- Yun HS, Kwon C, Kang BG, Lee JS, Han TJ, Chang SC, Kim SK (2005) A xyloglucan endotransglycosylase/hydrolase1, VrXTH1, is associated with cell elongation in mungbean hypocotyls. *Physiol Plantarum* 125:106–113
- Zeng Y, Kermod A (2004) A gymnosperm *ABI3* gene functions in a severe abscisic acid-insensitive mutant of *Arabidopsis* (*abi3-6*) to restore the wild-type phenotype and demonstrates a strong synergistic effect with sugar in the inhibition of post-germinative growth. *Plant Mol Biol* 56:731–746
- Zhang YY, Xie Q (2007) Ubiquitination in abscisic acid-related pathway. *J Integr Plant Biol* 49:87–93
- Zhang W, Qin C, Zhao J, Wang X (2004) Phospholipase D alpha 1-derived phosphatidic acid interacts with ABI1 phosphatase 2C and regulates abscisic acid signaling. *Proc Nat Acad Sci USA* 101:9508–9513
- Zhang W, Ruan J, Ho THD, You Y, Yu T, Quatrano RS (2005) *Cis*-regulatory element based targeted gene finding: genome-wide identification of abscisic acid- and abiotic stress-responsive genes in *Arabidopsis thaliana*. *Bioinformatics* 21:3074–3081
- Zhang A, Jiang M, Zhang J, Tan M, Hu X (2006) Mitogen-activated protein kinase is involved in abscisic acid-induced antioxidant defense and acts downstream of reactive oxygen species production in leaves of maize plants. *Plant Physiol* 141:475–487
- Zhang A, Jiang M, Zhang J, Ding H, Xu S, Hu X, Tan M (2007a) Nitric oxide induced by hydrogen peroxide mediates abscisic acid-induced activation of the mitogen-activated protein kinase cascade involved in antioxidant defense in maize leaves. *New Phytol* 175:36–50
- Zhang HM, Rong HL, Pillbeam D (2007b) Signalling mechanisms underlying the morphological responses of the root system to nitrogen in *Arabidopsis thaliana*. *J Exp Bot* 58:2329–2338
- Zhang JF, Yuan LJ, Shao Y, Du W, Yan DW, Lu YT (2008) The disturbance of small RNA pathways enhanced abscisic acid response and multiple stress responses in *Arabidopsis*. *Plant Cell Environ* 31:562–574
- Zhao JF, Zhang WH, Zhao Y, Gong XM, Guo L, Zhu GL, Wang XC, Gong ZZ, Schumaker KS, Guo Y (2007) SAD2, an importin beta-like protein, is required for UV-B response in *Arabidopsis* by mediating MYB4 nuclear trafficking. *Plant Cell* 19:3805–3818
- Zhou R, Cutler AJ, Ambrose SJ, Galka MM, Nelson KM, Squires TM, Loewen MK, Jadhav AS, Ross ARS, Taylor DC, Abrams SR (2004) A new abscisic acid catabolic pathway. *Plant Physiol* 134:361–369
- Zhu JH, Verslues PE, Zheng XW, Lee B, Zhan XQ, Manabe Y, Sokolchik I, Zhu YM, Dong CH, Zhu JK, Hasegawa PM, Bressan RA (2005) *HOS10* encodes an R2R3-type MYB transcription factor essential for cold acclimation in plants. *Proc Nat Acad Sci USA* 102:9966–9971
- Zimmerli L, Hou BH, Tsai CH, Jakab G, Mauch-Mani B, Somerville S (2008) The xenobiotic beta-aminobutyric acid enhances *Arabidopsis* thermotolerance. *Plant J* 53:144–156
- Zsigmond L, Rigo G, Szarka A, Szekely G, Otvos K, Darula Z, Medzihradzky KF, Koncz C, Koncz Z, Szabados L (2008) *Arabidopsis* PPR40 connects abiotic stress responses to mitochondrial electron transport. *Plant Physiol* 146:1721–1737



## Stress Signaling II: Calcium Sensing and Signaling

Marie Boudsocq and Jen Sheen\*

*Department of Molecular Biology, Massachusetts General Hospital & Department of Genetics, Harvard Medical School, Boston, MA 02114, USA*

Summary .....	75
I Introduction .....	76
II Calcium Signals .....	76
A Calcium Signatures .....	76
B Role of Calcium Signatures .....	77
C Calcium Channels, Pumps and Transporters .....	78
III Calcium Sensing and Signaling .....	78
A Sensor Relays .....	79
1 Calmodulin and Calmodulin-Like Sensors .....	79
2 Calcineurin B-Like Sensors .....	81
B Sensor Protein Kinases .....	83
1 Calcium-Dependent Protein Kinases .....	83
2 Calcium and Calmodulin-Dependent Protein Kinases .....	85
3 Other Calcium-Binding Proteins .....	85
IV Conclusions .....	86
Acknowledgements .....	86
References .....	86

### Summary

Calcium is an essential second messenger in plant signaling networks. Many environmental and developmental stimuli induce an increase in cytosolic calcium to trigger different physiological responses. The specificity of Ca<sup>2+</sup> signaling is achieved by a combination of distinct calcium signatures that are generated by specific calcium channels, pumps and transporters, and diverse calcium sensors that differ by their expression pattern, sub-cellular localization, substrate specificities and calcium sensitivities. Calcium binding modifies the structural conformation or enzymatic activity of the calcium sensors, which subsequently regulate downstream targets. Calmodulin is the most important Ca<sup>2+</sup> transducer in eukaryotes and regulates numerous proteins with diverse cellular functions, including protein kinases. Plants also possess specific multigene families of protein kinases that play crucial roles in mediating calcium signaling. The multiplicity and diversity of plant calcium sensors, as well as the interconnections between various signal transduction pathways, constitute a tightly regulated signaling network that induces specific stress responses to improve plant survival.

**Keywords** Calcineurin B-like • calcium • calcium-dependent protein kinase • calcium sensing • calcium signatures • calmodulin • stress signaling

---

\* Author for Correspondence, e-mail: sheen@molbio.mgh.harvard.edu

## I Introduction

Calcium is an essential plant nutrient that plays structural roles in the cell wall and membranes, and regulates plant growth and development (Hepler 2005). However, to avoid toxicity, calcium is maintained at low levels in the cytosol through the activation of calcium pumps and storage in multiple intracellular compartments as well as extracellular spaces (Fig. 1) (Sanders et al. 2002). While the role of calcium seems to be limited in prokaryotes (Dominguez 2004), it has evolved to be a ubiquitous second messenger in plants that mediates complex responses to developmental and environmental cues. Many external and internal signals can strongly, rapidly and transiently increase cytosolic calcium  $[Ca^{2+}]_{\text{cyt}}$ , through the regulation of diverse calcium transport systems (Fig. 1). The abundance of buffering calcium binding proteins in the cytosol can reduce calcium mobility and facilitate the localized and spatially distinct elevations in calcium concentrations (White and Broadley 2003). These calcium signals can be decoded by protein sensors which display an altered conformation and/or activity upon calcium binding. Understanding the specificity of calcium signaling has been a major challenge in plant biology for decades, since many diverse stimuli generate  $Ca^{2+}$  signals to trigger totally different responses. This signaling specificity can be achieved by different features of calcium signatures, distinct calcium sensitivities, expression and localization of calcium sensors and their downstream relay partners, as well as interactions with other signaling cascades. This review provides an overview of plant calcium signaling in response to abiotic stresses.

**Abbreviations** ABA—abscisic acid; ACA—auto-inhibited  $Ca^{2+}$ -ATPase; cADPR—cyclic ADP Ribose; CaM—calmodulin; CaMBP—calmodulin-binding protein; CAMTA—calmodulin-binding transcription activator; CBK—calmodulin-binding protein kinase; CBL—calcineurin B-like; CcCaMK—calcium and calmodulin-dependent protein kinase; CDPK—calcium-dependent protein kinase; CIPK—CBL-interacting protein kinase; CML—calmodulin-like; CNGC—cyclic-nucleotide gated channel; cNMP—cyclic nucleotide monophosphate; CRK—CDPK-related protein kinase; DGK—diacylglycerol kinase; GABA— $\gamma$ -aminobutyric acid; GAD—glutamate decarboxylase;  $IP_3$ —inositol triphosphate; MAPK—mitogen-activated protein kinase; PA—phosphatidic acid; PI-PLC—phosphoinositide-specific phospholipase C; PLD—phospholipase D; SOS—salt-overly sensitive

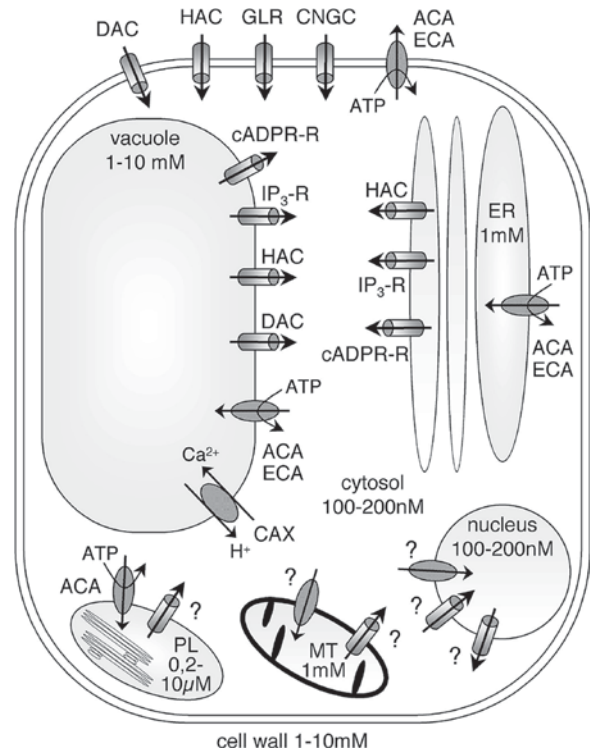

*Fig. 1.* Schematic representation of  $Ca^{2+}$ -permeable channels, pumps and transporters that are proposed to be involved in calcium signaling in response to abiotic stresses.  $Ca^{2+}$ -permeable channels (cylinders) can be regulated by voltage, either hyperpolarization (HAC) or depolarization (DAC) or ligands. The ligand-gated channels include  $IP_3$  receptors ( $IP_3$ -R), cADPR receptors (cADPR-R), glutamate receptors (GLR) and cyclic nucleotide-gated channels (CNGC). Genes encoding HAC, DAC,  $IP_3$ -R and cADPR-R have not been identified in plants.  $Ca^{2+}$ -pumps and transporters (ovals) comprise ACA and ECA  $Ca^{2+}$ -ATPases, and the CAX  $Ca^{2+}/H^+$ -antiporters. Biochemical and electrophysiological evidence indicate the presence of  $Ca^{2+}$  transport systems involved in stress responses in the mitochondria (MT) and the nucleus, but their molecular identity is not clear yet. Currently, there is no evidence for the involvement of plastids (PL) in regulating abiotic stress  $Ca^{2+}$  signals. The estimated calcium concentration is indicated for each cellular compartment (Pauly et al. 2001; Reddy and Reddy 2004) (Adapted from Reddy and Reddy 2004).

## II Calcium Signals

### A Calcium Signatures

Valuable tools have been developed to monitor  $[Ca^{2+}]_{\text{cyt}}$ . Fluorescent dyes, like fluo-4, fura-2 and indo-1, allow single-cell calcium imaging, whereas the calcium-sensitive luminescent protein aequorin

can be expressed in different cellular compartments (Knight et al. 1991; Reddy and Reddy 2004). The cameleon probe, which is based on green fluorescent protein, has been adapted for plant systems to provide non-invasive features and high calcium sensitivity (Allen et al. 1999). Using these tools, increase in  $[Ca^{2+}]_{\text{cyt}}$  has been monitored in response to many abiotic stresses in plants (Scrase-Field and Knight 2003; White and Broadley 2003). Calcium signals are defined by kinetic parameters (amplitude, duration, frequency, lag time) and spatial features (calcium origin and localization), and a particular combination of these factors appears to be specific to each stimulus (Table 1). The calcium response also depends on the strength of the stimulus, allowing a tight regulation of subsequent responses (Pauly et al. 2001). The use of calcium chelators or inhibitors of calcium channels indicates that different calcium sources are involved, depending on the stimuli (White and Broadley 2003). For example, similar calcium kinetics induced by cold and touch result from different calcium sources and locations (Knight et al. 1991; Wood et al. 2000), which eventually contributes to response specificity. Furthermore, refractory periods, during which seedlings can still respond to other stimuli, have been described (Price et al. 1994), further demonstrating that distinct signals mobilize calcium from different stores. In addition to the cytosol, abiotic stresses also induce calcium elevation in other cellular compartments, including the nucleus and mitochondria (Subbaiah et al. 1998; van der Luit et al. 1999; Pauly et al. 2001). Interestingly, the  $Ca^{2+}$  signatures of organelles are independent of the cytosolic  $Ca^{2+}$  signals (Pauly et al. 2000; Logan and Knight 2003). Calcium signatures are also cell type and organ-specific in

response to various abiotic stresses (Kiegle et al. 2000; White and Broadley 2003).

### B Role of Calcium Signatures

Because calcium changes have been associated with various downstream physiological responses to abiotic stresses (Reddy and Reddy 2004), calcium signatures may be relevant for encoding specific information for proper adaptation to distinct conditions. For example, impairing calcium signals with chelators or channel inhibitors reduces plant tolerance to freezing (Monroy et al. 1993) and heat shock (Gong et al. 1998), whereas calcium treatment increases plant survival. Although calcium has been proposed to act simply as a chemical switch (Scrase-Field and Knight 2003), several lines of evidence suggest that calcium signals can also carry specific information that distinguishes the various abiotic stresses. For example, in tobacco seedlings, wind and cold induce the expression of *NpCaM-1* in a  $Ca^{2+}$ -dependent manner. Although both stresses increase  $Ca^{2+}$  level in cytosol and nucleus, cytosolic calcium triggers *NpCaM-1* induction by cold, whereas nuclear calcium is responsible for *NpCaM-1* induction by wind (van der Luit et al. 1999). Thus, calcium elevation in the same cellular compartment may display different functions, depending on the stimulus. Recently, artificial cytosolic calcium transients have been shown to induce rapid transcriptome changes resembling abscisic acid (ABA) responses in *Arabidopsis* seedlings, further demonstrating that a particular calcium signal can induce specific gene expression patterns (Kaplan et al. 2006). Studies on stomatal regulation in guard cells also support a specific

Table 1. Calcium signatures in response to abiotic stresses.

Stimulus	Features of the cytosolic calcium signal	Calcium stores
Cold shock	Rapid and transient $Ca^{2+}$ peak (seconds)	Mainly external
Slow cooling	Bimodal $Ca^{2+}$ elevation (minutes)	External and internal (vacuole, $IP_3$ -dependent)
Hyperosmotic and salt stress	Single or biphasic $Ca^{2+}$ elevation (20–60 s)	External and internal (vacuole, $IP_3$ -dependent)
Hypoosmotic stress	Rapid and bimodal $Ca^{2+}$ elevation (minutes)	External and internal (ER)
Mechanical stress	Rapid and transient $Ca^{2+}$ peak (seconds)	Internal
Oxidative stress	Single $Ca^{2+}$ peak (minutes)	External and internal
Anoxia	Rapid and sustained $Ca^{2+}$ elevation (hours)	Internal (mitochondria)
Heat shock	Sustained $Ca^{2+}$ increase (15–30 min)	External and internal

References: See review Scrase-Field and Knight (2003), White and Broadley (2003).

role of calcium signatures. In the *det3* mutant, the altered calcium signal, induced by oxidative stress, fails to trigger stomatal closure, while calcium responses to cold and ABA are maintained. Artificially imposing the calcium oscillations, observed in wild-type plants, restores stomatal closure in *det3*, indicating that the calcium signal itself carries the information that induces specific responses (Allen et al. 2000). In addition, pre-treatment of seedlings with a stimulus modifies calcium signals induced by other stresses, suggesting that calcium may act as a memory signal to help adjust better to subsequent unfavorable conditions (White and Broadley 2003).

### C Calcium Channels, Pumps and Transporters

Increase in  $[Ca^{2+}]_{cyt}$  results from a combination of calcium influx into the cytosol via  $Ca^{2+}$ -permeable channels, according to the electrochemical potential, and calcium efflux out of the cytosol through energy-dependent calcium ATPases and transporters (Fig. 1) (Sanders et al. 2002).  $Ca^{2+}$ -permeable channels, which can be activated by hyper-polarization, depolarization or ligand binding, such as glutamate, inositol triphosphate ( $IP_3$ ), cyclic ADP ribose (cADPR) and cyclic nucleotide monophosphate (cNMPs), have been found in many different plant membranes (White and Broadley 2003; Hetherington and Brownlee 2004). Although the molecular identity of these channels is mostly unknown, their activities in response to abiotic stresses and the ability of the ligands to elicit calcium signals have been well documented (White and Broadley 2003; Reddy and Reddy 2004; Peiter et al. 2005; Carpaneto et al. 2007). For example,  $IP_3$  and cADPR can induce calcium release from the vacuole and trigger the induction of stress-responsive genes such as *RD29A* (Wu et al. 1997; Xiong et al. 2002). The recent annotation and cloning of genes encoding putative calcium channels provides important tools to study their involvement in generating calcium signals (Sanders et al. 2002). The glutamate receptor *GLR3.3* mediates calcium entry into the cytosol (Qi et al. 2006) and over-expression of *AtGluR2/GLR3.2* confers hypersensitivity to  $Na^+$  and  $K^+$  ions, but not to mannitol (Kim et al. 2001). Thus, *AtGluR2/GLR3.2* may play

a specific role in  $Ca^{2+}$ -mediated adaptation to ionic stresses. Recently, the  $Ca^{2+}$ -sensing receptor CAS has been shown to control the  $Ca^{2+}$ -resting level and to regulate  $IP_3$  concentrations in *Arabidopsis* (Tanget al. 2007). Cyclic-nucleotide gated channels (CNGCs), that are activated by cNMPs, can conduct several types of cations, including calcium (Sanders et al. 2002; Lemtiri-Chlieh and Berkowitz 2004). However, the functional role of CAS and CNGCs in mediating abiotic stress signaling requires further investigation.

Calcium efflux from the cytosol allows replenishment of internal and external stores (Fig. 1), and a return to resting calcium levels, which may contribute to shaping the specific and distinct calcium signatures.  $Ca^{2+}$  pumps, whose expression is induced by salt stress, include the endoplasmic reticulum (ER)-type  $Ca^{2+}$ -ATPases (ECA or type IIA) and the auto-inhibited  $Ca^{2+}$ -ATPases (ACA or type IIB) (Fig. 1) (Geisler et al. 2000; Sze et al. 2000). Interestingly, the *Arabidopsis* vacuolar ACA4 restores growth on NaCl and mannitol in a mutant yeast strain, suggesting a positive role of ACA4 in plant stress tolerance (Geisler et al. 2000). Among the transporters, the vacuolar  $Ca^{2+}/H^+$  antiporter CAX1, which is induced by cold, has been shown to negatively regulate the cold-acclimation response in *Arabidopsis* by repressing the expression of *CBF/DREB1* genes and their downstream targets (Hirschi 1999; Catala et al. 2003).

### III Calcium Sensing and Signaling

Any modification in the concentration of calcium must subsequently be decoded in the targeted cells and organs to induce appropriate responses depending on the stimulus. Calcium sensors have been divided into two groups: the sensor relays, including calmodulin (CaMs) and calcineurin B-like (CBLs) proteins, and the sensor protein kinases, such as calcium-dependent protein kinases (CDPKs) as well as calcium and calmodulin-dependent protein kinases (CCaMKs). CaMs and CBLs do not possess any intrinsic activity and have to transmit the calcium-induced modification to target proteins, whereas CDPKs and CCaMKs are directly activated upon calcium binding (Fig. 2).



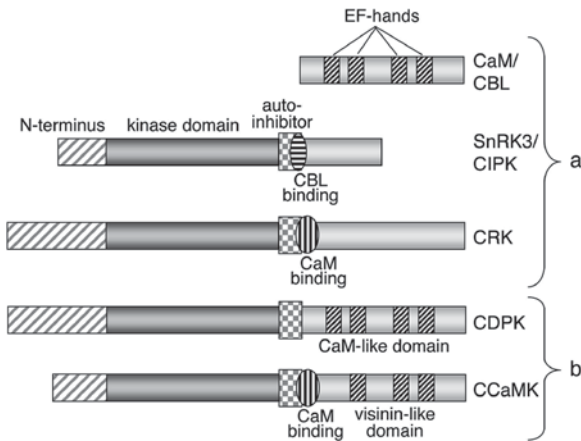

**Fig. 2.** Domain structure of plant calcium sensors. **(a)** Sensor relays and protein kinase partners. CaM and CBL are sensor relays that bind calcium through EF-hand motifs. CaM subsequently regulates many different target proteins including protein kinases (CRKs), whereas CBLs mainly activate CIPKs by interacting with the FISL/NAF domain (CBL binding) to release auto-inhibition; **(b)** Sensor protein kinases: In contrast to CRKs and CIPKs, the kinases CDPK and CCaMK can directly bind calcium through their EF-hand motifs. As a result, CDPKs function independently of other  $\text{Ca}^{2+}$  sensors whereas CCaMK activity can be further modulated by CaM (Adapted from Harper et al. 2004).

## A Sensor Relays

### 1 Calmodulin and Calmodulin-Like Sensors

#### 1.1 Biochemical Functions and Regulation of Calmodulin

Calmodulin is a small protein composed of two pairs of  $\text{Ca}^{2+}$  binding sites named EF-hands (Luan et al. 2002). Calcium binding modifies the CaM globular structure into an open conformation that allows interaction with proteins (Yamniuk and Vogel 2005). This interaction subsequently activates (Lee et al. 2000) or inhibits (Choi et al. 2005b; Yoo et al. 2005) CaM targets, translating a calcium signal into a biochemical response. The *Arabidopsis* genome contains seven *CaM* genes encoding four isoforms that differ by only one to four amino acids. In addition, *Arabidopsis* contains 50 genes encoding CaM-like (CMLs) proteins with more divergent sequences and sometimes extra-domains that confer additional properties (McCormack and Braam 2003). Specificity of CaM-mediated responses results

from different expression patterns, specific targets, calcium affinities, sub-cellular localization and methylation (Luan et al. 2002; McCormack and Braam 2003). CaM isoforms differ in their ability to regulate target proteins (Lee et al., 2000; Yoo et al. 2005), possibly due to different structural interactions of the targets with CaM (Yamniuk and Vogel 2005). A recent protein array study has identified 173 protein targets of seven CaMs/CMLs in *Arabidopsis*. Among them, about 25% interact with all CaMs/CMLs tested, 50% with at least two of them, and 25% are specific to one CaM/CML (Popescu et al. 2007). CaMs sharing the same targets can compete for binding (Lee et al. 1999), indicating that target proteins are tightly regulated depending on the amount of each CaM isoform. Interestingly, a mutation converting three amino acids of rice OsCaM1 into those of OsCaM61, confers an ability to activate OsCBK almost as efficiently as OsCaM61 (Li et al. 2006). Thus, CaMs exhibit outstanding target specificities despite high levels of sequence identity. Different  $\text{Ca}^{2+}$  sensitivities were observed depending on CaM and target proteins, adding another layer of regulation (Lee et al. 2000; Luoni et al. 2006). CaMs also display multiple sub-cellular localizations (Yang and Poovaiah 2003). Interestingly, the petunia CaM53 and rice OsCaM61 are targeted to membranes or the nucleus depending on their prenylation status (Luan et al. 2002). Finally, CaM methylation may be a specific regulatory mechanism for a subset of target proteins (Roberts et al. 1986).

#### 1.2 Calmodulin and Calmodulin-Like in Abiotic Stresses

The involvement of CaMs in abiotic stress responses was suggested by the reduced stress tolerance and gene expression observed after treatment with CaM antagonists (Monroy et al. 1993; Liu et al. 2003). In addition, expression of CaMs and CMLs is induced by touch, cold, heat shock or salinity (Luan et al. 2002; Yang and Poovaiah 2003). Also, it has been observed that heat shock enhances CaM protein level (Liu et al. 2003). Interestingly, over-expression of *Arabidopsis* CaM3 impairs cold induction of *RD29A*, *KIN1* and *KIN2* (Townley and Knight 2002), whereas *Arabidopsis* plants over-expressing the soybean GmCaM4 are more resistant to salinity (Yoo et al. 2005). This suggests a negative role of



CaM3 in cold signaling, while GmCaM4 positively regulates salt tolerance.

### 1.3 Calmodulin-Binding Proteins in Abiotic Stresses

As CaM has no enzymatic activity by itself, studying CaM-regulated proteins provides further evidence of CaM functions in abiotic stress responses. A large biochemical screen combined with computational analyses of homologs, identified about 100 putative CaM-binding protein genes (*CaMBPs*) in *Arabidopsis*. Most of these genes belong to multigene families, and some of them are induced by salinity, drought or cold (Reddy and Reddy 2004). In a recent protein array analysis, only a few newly identified CaM targets overlap with the previous study (Popescu et al. 2007), suggesting that the use of multiple strategies should facilitate the uncovering of the full spectrum of Ca<sup>2+</sup>/CaM-regulated proteins. This discrepancy is probably due to the use of distinct expression libraries and methodologies. These results also indicate that differential regulation by

CaM occurs among members of the same protein family. CaMBPs can be classified into two major groups: transduction proteins, such as protein kinases (CBKs) and transcription factors (CBTs) and effector proteins, including ion transporters and enzymes that directly function in physiological responses (Fig. 3).

Unlike in mammalian systems, CaM-regulated protein kinases (CaMKs) are not well characterized in plants. Apart from the chimeric CCaMKs (Fig. 2), only one protein kinase sharing similar structural features with mammalian CaMKs has been identified in apple (Harper et al. 2004). Plants also possess several CDPK-related protein kinases (CRKs) (Fig. 2), which are considered to be calcium-independent (Hrabak et al. 2003). However, new evidence suggests that some CRKs are stimulated by CaM in a Ca<sup>2+</sup>-dependent manner (Harper et al. 2004). The specific up-regulation of *NiCBK2* by salt stress suggests that CRKs may function in salt tolerance (Hua et al. 2004).

It is intriguing that CaMs show both positive and negative effects on transcription factors.

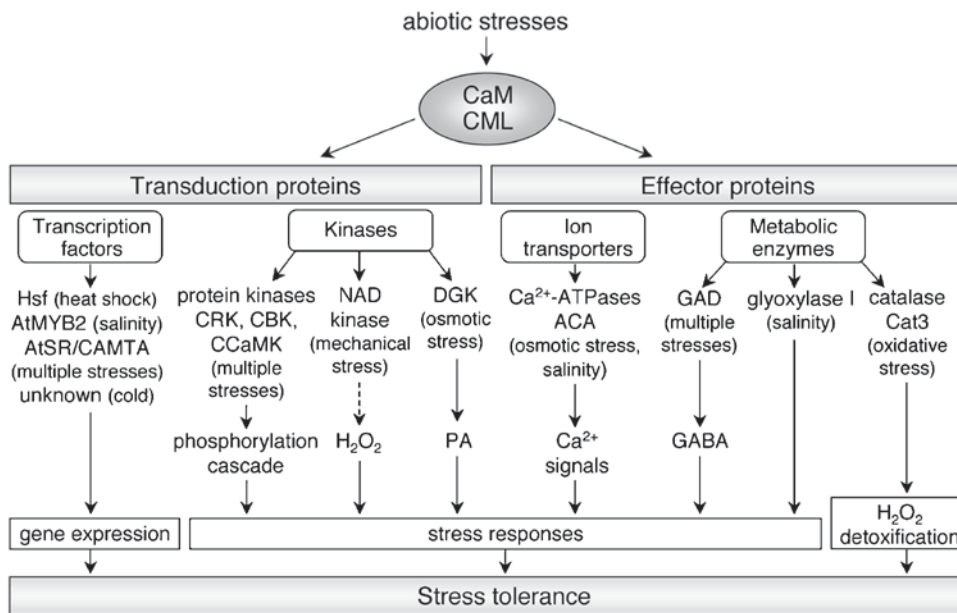

*Fig. 3.* CaM/CML functions in abiotic stress responses. The stress-activated CaMs/CMLs regulate multiple target proteins that are involved in diverse cellular processes such as transcription, signaling, ion transport and metabolism. Different types of kinases are responsible for initiating protein phosphorylation cascades, or inducing the direct (plain line) or indirect (dotted line) production of second messengers (H<sub>2</sub>O<sub>2</sub>, PA) to trigger stress responses. CaMs/CMLs also positively and negatively regulate transcription factors to modulate gene expression. Some specific roles, like H<sub>2</sub>O<sub>2</sub> detoxification or generation of Ca<sup>2+</sup> fluxes, have been established for several effector proteins regulated by CaM/CML. The underlying mechanism that leads to stress tolerance by modulating GAD and glyoxylase I is not clear. For each target protein, the activating stimuli are indicated in brackets.

During the heat shock response, CaM induces the expression of *HSP* genes (Liu et al. 2003) and increases the DNA binding of heat shock transcription factors (Li et al. 2004). GmCaM4 activates the transcription factor AtMYB2, and over-expression of GmCaM4 confers salt tolerance, that correlates with the enhanced expression of AtMYB2 target genes (Yoo et al. 2005). In contrast, CaM inhibits the transcriptional activation mediated by OsCBT (Choi et al. 2005b), which has similar structural features as *Arabidopsis* transcription activators AtSRs/CAMTAs (calmodulin binding transcription activator), which are induced by multiple stresses at the transcript level (Yang and Poovaiah 2003; Bouché et al. 2005).

Emerging evidence also suggests an involvement of  $\text{Ca}^{2+}$ /CaM in  $\gamma$ -aminobutyric acid (GABA) regulation, tolerance to oxidative stress, heat shock, as well as osmotic and salt tolerance through the regulation of effector proteins (Bouché et al. 2005). For example, glutamate decarboxylase (GAD), that triggers GABA accumulation in response to abiotic stresses, is activated by CaM in vitro (Lee et al. 2000). CaM has been proposed to play a dual role in regulating  $\text{H}_2\text{O}_2$  homeostasis. On one hand, CaM induces  $\text{H}_2\text{O}_2$  production by activating NAD kinase (Bouché et al. 2005). On the other hand, CaM induces detoxification by activating the catalase AtCat3 (Yang and Poovaiah 2002). Thus, CaM can regulate both effects of  $\text{H}_2\text{O}_2$ , i.e. mediate stress responses as a second messenger and induce cellular damage at higher concentration.

CaM is also a major regulator in salt and osmotic tolerance (Bouché et al. 2005). CaM stimulates the activity of glyoxylase I, an enzyme that positively functions in salt tolerance (Bouché et al. 2005). AtCaMBP25 is a small nuclear CaMBP, which plays a negative role in osmotic and salt tolerance (Perruc et al. 2004). In addition to regulation of protein activity, CaM also modifies cellular localization of target proteins. CaM recruits a tomato diacylglycerol kinase (LeDGK) to membranes where its substrate is located (Yang and Poovaiah 2003). As DGK produces phosphatidic acid (PA), involved in abiotic stress signaling (Xiong et al. 2002; Bargmann and Munnik 2006), CaM may play a positive role in stress responses by regulating PA signaling. Finally, CaM stimulates the activity of *Arabidopsis* type IIB  $\text{Ca}^{2+}$ -ATPases, ACA2 and ACA8, by releasing

auto-inhibition (Hwang et al. 2000; Luoni et al. 2006). As ACA4 confers osmo-protection and resistance to salinity when over-expressed in yeast (Geisler et al. 2000), CaM may regulate calcium flux in response to multiple abiotic stresses.

## 2 Calcineurin B-Like Sensors

### 2.1 Structure and Functions of Calcineurin B-Like proteins in Abiotic Stresses

Like CaMs, CBLs are small proteins composed of two globular domains connected by a short linker. Each domain contains two EF-hand motifs harboring variable degrees of conservation compared to canonical sequences in CaMs, suggesting different  $\text{Ca}^{2+}$  capacities and affinities that most likely contribute to response specificity (Nagae et al. 2003). Crystal structure analysis has revealed that CBL2 binds two  $\text{Ca}^{2+}$  ions, while CBL4/SOS3 (salt-overly sensitive 3) binds four  $\text{Ca}^{2+}$  ions (Nagae et al. 2003; Sanchez-Barrena et al. 2005). Upon calcium binding, CBLs undergo conformational changes that allow hydrophobic interactions with other proteins (Sanchez-Barrena et al. 2005). In addition, several CBLs possess a putative myristoylation site that may promote membrane association (Kolukisaoglu et al. 2004). CBL4/SOS3 is myristoylated in vitro and associated with microsomal membranes (Ishitani et al. 2000), while CBL1 and CBL9 are targeted to the plasma membrane (Cheong et al. 2007). Interestingly, calcium binding also induces CBL4/SOS3 dimerization, which could reinforce membrane association (Sanchez-Barrena et al. 2005). Thus, the CBLs, comprising ten members in both *Arabidopsis* and rice (Kolukisaoglu et al. 2004), are calcium sensors that transmit the signal through protein interactions and can regulate the sub-cellular localization of their targets.

Exposure to cold, drought, salinity and ABA, differentially regulates *CBL* gene expression, suggesting a role for CBLs in abiotic stress responses (Baticic and Kudla 2004). SOS3/CBL4 was the first CBL identified by a genetic approach. The loss-of-function mutant is hypersensitive to salinity but displays the wild type response to osmotic stress. The mutant protein exhibits reduced calcium binding (Xiong et al. 2002). This indicates a specific role for SOS3/CBL4 in salt tolerance through calcium sensing. In addition, SOS3 myristoylation is required for salt tolerance, suggesting the importance of membrane association (Ishitani

et al. 2000). Recently, CBL10 has been shown to have overlapping functions with SOS3 in salt tolerance (Quan et al. 2007). Interestingly, CBL1 plays a broader role in regulating plant responses to salt, drought and cold (Albrecht et al. 2003; Cheong et al. 2003). The alteration of gene expression and the stress phenotypes of the mutant *cbll* and *CBL1* over-expressing plants indicate that CBL1 is a positive regulator of drought and salt responses, but a negative regulator of the cold response (Cheong et al. 2003). While CBL1 exhibits ABA-independent functions, the closest related CBL9 acts as a negative regulator of ABA signaling, during germination and early development (Pandey et al. 2004). Surprisingly, unlike the *cbll* and *cb19* single mutants, the *cbllcb19* double mutant displays lower water loss under dehydration conditions due to ABA hypersensitivity for stomata closure (Cheong et al. 2007). Thus, CBLs exhibit complex redundant and specific functions, probably due to different expression patterns, interacting partners and cellular or sub-cellular localizations.

## 2.2 Calcineurin B-Like-Interacting Protein Kinases in Abiotic Stresses

CBLs share high sequence similarity to the regulatory subunit (CNB) of yeast calcineurin (CNA), a protein phosphatase involved in salt tolerance. However, yeast two-hybrid screens identified a family of Ser/Thr protein kinases (CIPKs) as the main plant CBL partner (Luan et al. 2002; Batistic and Kudla 2004; Reddy and Reddy 2004). CIPKs or PKS (SOS2-like protein kinases) belong to the SNF1-related protein kinase 3 (SnRK3) family, which possesses a unique C-terminal domain (Hrabak et al. 2003; Harper et al. 2004). The FISL/NAF domain in the C-terminus of CIPKs is sufficient for interaction with CBLs (Fig. 2), but the N-terminal domain contributes to the specificity of this interaction (Batistic and Kudla 2004). There are 25 and 30 CIPKs in *Arabidopsis* and rice, respectively, and differential CBL-CIPK interactions are detected even with closely related members (Batistic and Kudla 2004; Kolukisaoglu et al. 2004). Although these experiments were performed in the yeast two-hybrid system, they may reflect the formation of distinct CBL-CIPK complexes in plants. Accordingly, CBL-CIPK complexes exhibit different biochemical features in vitro, such as Ca<sup>2+</sup>-dependence of interaction, cofactor and substrate specificity that may reflect different regulatory mechanisms in vivo resulting in

response specificity (Luan et al. 2002; Batistic and Kudla 2004). CBL-CIPK interactions stimulate kinase activity and target the complex to plasma membrane, where CIPKs can phosphorylate specific substrates (Batistic and Kudla 2004; Gong et al. 2004; D'Angelo et al. 2006).

Differential stress induction of CIPK genes has been reported in distinct plant species, suggesting a role for these kinases in abiotic stress responses (Batistic and Kudla 2004). The most studied CIPK protein SOS2/CIPK24 was shown to be specifically involved in salt tolerance. Genetic analyses have demonstrated that the Na<sup>+</sup>/H<sup>+</sup> antiporter SOS1, SOS2/CIPK24 and SOS3/CBL4 function in the same pathway (Xiong et al. 2002). SOS2/CIPK24 is inactivated by an intramolecular interaction, which is released upon binding to SOS3/CBL4 that senses salinity-induced calcium increase. Subsequently, SOS3/CBL4 targets the active kinase to the plasma membrane where it phosphorylates and activates SOS1, leading to Na<sup>+</sup> extrusion (Gong et al. 2004). Recently, CBL10 has also been shown to activate SOS2/CIPK24 and its downstream target SOS1 to trigger salt tolerance. Analysis of mutant phenotypes reveals that CBL10 mainly functions in shoot response to salt toxicity, whereas SOS3 primarily acts in roots (Quan et al. 2007).

The analysis of loss-of-function mutants indicates that CIPK3 is involved in cold and ABA-dependent salt stress responses, and positively regulates the early phase of stress-induced gene expression (Kim et al. 2003). CIPK1 mediates plant responses to osmotic stress, but not cold and salinity (D'Angelo et al. 2006). Interestingly, CIPK1 interacts with both CBL1 and CBL9, and the three loss-of-function single mutants exhibit hypersensitivity to osmotic stress. However, disruption of only CIPK1 or CBL9 impairs ABA responsiveness (Cheong et al. 2003; Pandey et al. 2004; D'Angelo et al. 2006). Thus, CIPK1 may regulate ABA-dependent and ABA-independent plant stress responses through alternative complexes with CBL9 and CBL1, respectively (D'Angelo et al. 2006). As freezing and salt tolerance are not affected in the *cipk1* mutant (D'Angelo et al. 2006), the functions of CBL1 in cold and salt signaling must be mediated by another CIPK. Considering the interactions detected in yeast two-hybrid assays, CBL1 may regulate CIPK24/SOS2 in response to salinity, but the partner in cold signaling remains to be iden-

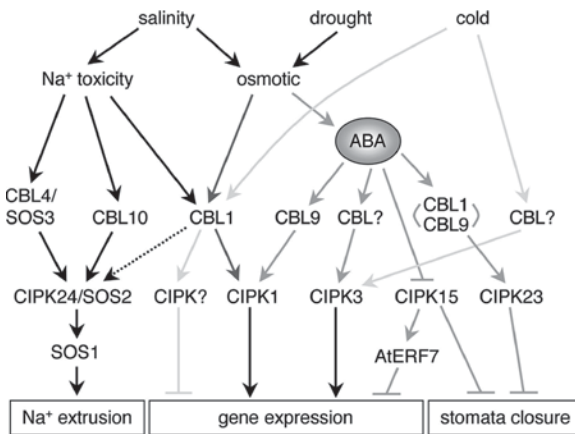

Fig. 4. CBL-CIPK signaling network in abiotic stress responses. Besides the well-studied SOS2/SOS3 pathway required for salt tolerance, other CBLs and CIPKs mediate regulation of gene expression and stomatal movements in ABA-dependent and ABA-independent pathways. While CBL4/SOS3 and CBL10 display overlapping functions to regulate CIPK24/SOS2 in different organs, CBL1 and CBL9 compete for CIPK1 regulation but act synergistically to modulate CIPK23. However, in some cases, only one partner has been shown to be involved in stress responses and specific CBL-CIPK complexes remain to be identified *in vivo*.

tified since CIPK3 does not interact with CBL1 (Kolukisaoglu et al. 2004). Recently, CBL1 and CBL9 were shown to act synergistically to activate CIPK23 and to inhibit ABA-dependent stomatal closure (Cheong et al. 2007). Furthermore, PKS3/CIPK15 was identified as a negative regulator of ABA signaling. In particular, the *pk3* mutant displays ABA hypersensitivity towards stomatal closure, leading to reduced water loss during dehydration (Guo et al. 2002). PKS3/CIPK15 also represses ABA-inducible genes through activation of AtERF7, a transcriptional repressor in ABA signaling (Song et al. 2005). These studies demonstrate that CIPK-CBL complexes form a highly regulated network through competition for partners, allowing a subtle regulation of calcium-dependent plant responses to abiotic stresses (Fig. 4).

## B Sensor Protein Kinases

### 1 Calcium-Dependent Protein Kinases

#### 1.1 Structure and Regulation

##### of Calcium-Dependent Protein Kinases

CDPKs harbor a protein kinase domain linked to a CaM-like domain through a junction

sequence that keeps the kinase inactive via a pseudosubstrate-binding mechanism (Fig. 2). The kinase activation results from intramolecular interaction between the CaM-like domain and the auto-inhibitory junction due to a Ca<sup>2+</sup>-induced conformational change (Cheng et al. 2002; Harper et al. 2004). CDPKs are encoded by multigene families of 34 and 29 members in *Arabidopsis* and rice, respectively (Cheng et al. 2002; Asano et al. 2005). The significance of this multiplicity can be explained by the differences in Ca<sup>2+</sup> activation thresholds, substrate recognition, expression patterns and sub-cellular localization (Cheng et al. 2002; Harper et al. 2004). It is likely that distinct CDPKs can sense and respond to different Ca<sup>2+</sup> signatures. CDPKs display specificities on artificial substrates *in vitro* (Lee et al. 1998) that may reflect substrate specificities *in vivo* (Choi et al. 2005a; Rodriguez Milla et al. 2006).

Apart from Ca<sup>2+</sup> activation, CDPK activity can be further modulated depending on isoforms. The identification of CDPK auto-phosphorylation sites in either the N-terminal variable domain, kinase domain or CaM-like domain suggests that they may differentially affect CDPK localization, activity, Ca<sup>2+</sup> binding or protein interaction (Hegeman et al. 2006). Interestingly, 14-3-3 proteins that regulate enzymes after binding to phosphorylated sites can stimulate AtCPK1 activity (Camoni et al. 1998). Considering the variations in CDPK auto-phosphorylation sites, the 14-3-3 stimulation may represent a specific regulatory mechanism for a subset of CDPKs. CDPK activity is also modulated by phospholipids (Harper et al. 2004). Some of these phospholipids, like PA, act as second messengers (Xiong et al. 2002), which may play their signaling role through CDPK regulation. Generally, these phospholipids function as structural component of membrane and stimulate activity of CDPKs that are more active when associated with a membrane (Li et al. 1998). Importantly, CDPKs have been shown to localize in many different cellular compartments, including the nucleus, cytosol, chloroplast, peroxisome, ER and plasma membrane (Dammann et al. 2003; Harper et al. 2004). Myristoylation, an irreversible protein modification, is required for membrane targeting and insertion of CDPKs (Martin and Busconi 2000). Membrane association can be maintained by additional interactions, either via a cluster of positively charged amino



acids (Chehab et al. 2004) or by reversible palmitoylation (Martin and Busconi 2000). Thus, the unique structure of CDPKs provides an efficient co-targeting of a kinase and its  $\text{Ca}^{2+}$  regulator to coordinate  $\text{Ca}^{2+}$  sensing with cellular responses. It also allowed the co-evolution of kinases with divergent  $\text{Ca}^{2+}$ -binding domains to acquire the ability to respond to different  $\text{Ca}^{2+}$  signals.

### 1.2 Calcium-Dependent Protein Kinases in Abiotic Stress Signaling

Currently, only a few members of the CDPK protein family have been analyzed and shown to be specifically involved in stress responses. Progress has been slow because of the extensive functional redundancy of these proteins (Sheen 1996; Choi et al. 2005a). Expression of many CDPKs can be increased by abiotic stresses (Cheng et al. 2002). Transcriptional induction is consistent with the presence of stress-responsive *cis*-element in rice *CDPK* promoters (Wan et al. 2007) and correlates with enhanced protein levels (Abbasi et al. 2004; Yu et al. 2006). Furthermore, changes in intracellular localization of CDPKs have been observed in response to abiotic stresses. The groundnut AhCPK2 is translocated to the nucleus under hyper-osmotic conditions through an interaction with importins (Raichaudhuri et al. 2006). In the ice plant, McCPK1 moves from the plasma membrane to the nucleus after exposure to low humidity and salt stress (Patharkar and Cushman 2000; Chehab et al. 2004). Interestingly, the pseudo-response regulator transcription factor CSP1, which constitutes an *in vitro* substrate of McCPK1, is able to bind promoters of stress-inducible genes (Patharkar and Cushman 2000). In a maize protoplast transient expression assay, *Arabidopsis* CPK10 and CPK30, among several tested protein kinases, can specifically activate the promoter of the *HVA1* barley gene that is responsive to ABA, cold and salinity (Sheen 1996). Thus, CDPKs play positive roles in abiotic stress responses by inducing the expression of stress-responsive genes in both monocots and dicots.

Using a recombinant peptide substrate of CDPK (LCSP), an increase in a  $\text{Ca}^{2+}$ -dependent kinase activity was reported after oxidative stress in tobacco (Shao and Harmon 2003). Moreover, phosphorylation by a CDPK releases the feedback inhibition of an enzyme (serine acetyltransferase 2;1) involved in the biosynthesis of cysteine. Since

the phosphorylation is induced by oxidative stress *in vivo*, CDPK may play a positive role in an anti-oxidative stress response by providing cysteine for glutathione production (Liu et al. 2006). CDPKs are also involved in cold signaling. In rice, a membrane-associated CDPK is activated after 18–24 h exposure to cold, suggesting a role in an adaptive process rather than in early responses (Martin and Busconi 2001). Similarly, OsCPK7/OsCDPK13 is activated by a 3 h cold treatment (Abbasi et al. 2004) and over-expression of either *OsCPK7/OsCDPK13* or *OsCPK13/OsCDPK7* confers cold tolerance in transgenic rice (Saijo et al. 2000; Abbasi et al. 2004).

Several lines of evidence indicate the involvement of CDPKs in drought responses. First, the dehydration-inducible gene *AtDi19* encodes a nuclear zinc finger protein that is a specific substrate of AtCPK4, 11 and 12 (Rodriguez Milla et al. 2006). Moreover, CDPK may reduce water loss under dehydration conditions by regulating diverse channel activities, such as the spinach aquaporin PM28A (Johansson et al. 1996). In faba bean guard cells, a CDPK phosphorylates the  $\text{K}^+$  inward channel KAT1 *in vitro* (Li et al. 1998), which results in inhibition of the channel activity and contributes to stomatal closure (Berkowitz et al. 2000). In contrast, AtCPK1 activates a vacuolar  $\text{Cl}^-$  channel, resulting in  $\text{Cl}^-$  uptake into the vacuole and stomatal opening (Pei et al. 1996). Drought responses and stomatal movements are regulated by ABA. In the *Arabidopsis cpk3cpk6* double mutant, ABA-induced stomatal closure is reduced, concomitant with an impaired ABA activation of slow-type anion channels and calcium permeable channels (Mori et al. 2006). Thus, AtCPK3 and AtCPK6 are both positive regulators of stomatal ABA signaling. However, their functions may not be redundant since they belong to distinct CDPK subfamilies (Cheng et al. 2002). Significantly, ABA stimulates the activity of the grape berry ACPK1 (Yu et al. 2006), which positively regulates ABA-induced stomatal closure and the expression of stress-responsive genes (Yu et al. 2007). In *Arabidopsis*, AtCPK32 phosphorylates and activates the ABA-responsive transcription factor ABF4, leading to enhanced expression of ABF4 target genes (Choi et al. 2005a). It is likely that multiple CDPKs act through ABF4 and related transcription factors to activate ABA and stress signaling (Sheen 1996; Choi et al. 2005a).



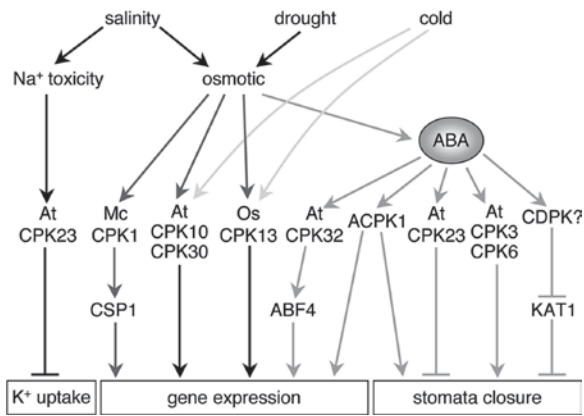

Fig. 5. CDPK signaling network in abiotic stress responses. CDPKs from different plant species regulate physiological responses to abiotic stresses, such as  $K^+$  uptake, gene expression and stomatal aperture. While some transcription factors (CSP1, ABF4) and channels (KAT1) have been identified as CDPK substrates, most of the downstream components in CDPK signaling pathways are still unknown.

In rice, plants over-expressing *OsCPK13/OsCDPK7* exhibit enhanced resistance to drought and salinity, correlated with increased expression of stress-responsive genes (Saijo et al. 2000). A recent study has shown that *AtCPK23*, distinct from *AtCPK10*, 30 and 32 (Cheng et al. 2002), appears to have a negative function in drought and salt responses (Ma and Wu 2007). In addition, CDPK also regulates  $Ca^{2+}$  signatures by inhibiting the  $Ca^{2+}$  pump ACA2 located in the ER (Hwang et al. 2000). Thus, CDPKs mediate abiotic stress responses by regulating stomatal aperture, channel activities and gene expression (Fig. 5).

## 2 Calcium and Calmodulin-Dependent Protein Kinases

CCaMKs have been identified in different plant species, but there is no evidence for their presence in *Arabidopsis* (Harper et al. 2004). CCaMKs possess an N-terminal kinase domain followed by two regulatory domains: a CaM-binding domain which overlaps with an auto-inhibitory region and a visinin-like domain containing 3 EF-hands (Fig. 2) (Sathyanarayanan and Poovaiah 2004). This leads to a complex regulatory mechanism involving both  $Ca^{2+}$  and  $Ca^{2+}/CaM$  binding. In this model, the auto-phosphorylation induced by  $Ca^{2+}$  binding to the visinin-like domain increases CaM affinity, whose subsequent binding releases auto-inhibition and

activates the kinase (Sathyanarayanan and Poovaiah 2004). Moreover, CCaMK activity is differentially modulated by CaM isoforms, adding another layer of regulation (Sathyanarayanan and Poovaiah 2004). In legume plants, CCaMKs play a critical role in Nod factor signaling and gene regulation essential for  $N_2$  fixation (Gleason et al. 2006). So far, only one study reported the involvement of CCaMKs in stress responses. In pea roots, PsCCaMK localizes to the nucleus and its protein level increases after cold and salt stress (Pandey et al. 2002). The dephosphorylated form of the protein p40 binds to the promoter of the stress-induced *AtCaM5*, which may blocks *AtCaM5* expression. As PsCCaMK phosphorylates p40 in vitro, PsCCaMK may release the repression of *AtCaM5* under stress conditions (Pandey et al. 2002).

## 3 Other Calcium-Binding Proteins

Three different types of  $Ca^{2+}$ -regulatory motifs have been characterized: EF-hands, C2 domain and annexin fold. Bioinformatics analysis identified 250 EF-hand-containing proteins in *Arabidopsis*, including some that are known to be involved in abiotic stress responses (Reddy and Reddy 2004).  $Ca^{2+}$  binding has been confirmed for the bHLH transcription factor *AtNIG1*, which localizes to the nucleus, and specifically binds to E-box sequences that are present in the promoter region of many salt stress-inducible genes. Although the effect of  $Ca^{2+}$  binding is unknown, the *Arabidopsis* knockout mutant *atnig1-1* exhibits hypersensitivity to salinity stress, suggesting that *AtNIG1* plays a positive role in salt tolerance (Kim and Kim 2006). Phosphoinositide-specific phospholipase C (PI-PLC) contains a C2 domain and an EF-hand motif, that is required for PLC activity (Otterhag et al. 2001). PI-PLCs are  $Ca^{2+}$ -dependent enzymes that trigger  $IP_3$ -dependent calcium release to modulate stress responses, including gene expression (Xiong et al. 2002; Reddy and Reddy 2004). As *AtPLC2* is predominantly localized in the plasma membrane (Otterhag et al. 2001), PI-PLCs may sense early increases in cytosolic calcium and enhance the signal by inducing further calcium release.

Phospholipase D (PLD)  $\alpha$ ,  $\beta$ ,  $\gamma$ ,  $\delta$  and  $\epsilon$ , which require different calcium concentrations for activity, contain a C2 domain involved in  $Ca^{2+}$ -dependent phospholipid binding (Reddy and Reddy 2004).

PLDs are implicated in ABA signaling and stress tolerance, through the generation of PA, which acts as an important second messenger in plant stress responses or by inducing membrane remodeling (Bargmann and Munnik 2006). Interestingly, PLD $\alpha$ 1 has been shown to mediate stomatal ABA signaling via a bifurcating pathway. On one hand, PA binding to ABI1 inhibits its phosphatase activity and leads to its sequestration to the plasma membrane, which then promotes stomatal closure. On the other hand, PLD $\alpha$ 1 can also interact with the heterotrimeric G protein GPA1, while PA acts upstream of GPA1, leading to activation of the G protein and inhibition of stomatal opening (Mishra et al. 2006). The C2 domain is present in many other proteins whose biological function awaits future investigations (Reddy and Reddy 2004).

Annexins are small proteins that bind phospholipids in a Ca<sup>2+</sup>-dependent manner (Sathyanarayanan and Poovaiah 2004). *Arabidopsis* genome contains eight annexin genes (*AnnAt*), that display differential induction by salinity, dehydration, cold and heat shock (Cantero et al. 2006). The protein levels of AnnAt1 and its association with the plasma membrane are increased by salt stress, and knockout mutants of AnnAt1 and AnnAt4 are hypersensitive to osmotic stress and ABA (Lee et al. 2004). This suggests that annexins may regulate target proteins at the plasma membrane to promote stress tolerance.

#### IV Conclusions

Calcium has emerged as an essential second messenger that mediates responses to developmental and stress stimuli in plants. Different signals have been proposed to elicit specific calcium signatures. Although several calcium channels and transporters have been identified at the molecular level, their specific roles in generating calcium signals in cytosol and sub-cellular compartments in response to stress remain to be elucidated. Understanding how these calcium signals are deciphered and relayed constitutes another challenge. Diverse plant calcium sensors are encoded by large multigene families, which provide robust redundant or unique functions to enhance plant's ability to adapt themselves to constantly changing environmental conditions. Response specificity is believed to occur

through different calcium sensitivities, expression, cellular localizations and substrate regulation. It will be interesting to determine whether CDPKs and CIPKs have distinct or overlapping roles in stress signaling. In addition, cross-talk between Ca<sup>2+</sup>-mediated transduction pathways contribute to highly modulated plant responses. For example, a subset of CDPK and CIPK proteins may also be regulated by CaM (Popescu et al. 2007), and AtCPK1 and CaM have opposite effects in regulating Ca<sup>2+</sup>-ATPase activity of ACA2 (Hwang et al. 2000). Although some protein targets of calcium sensors have been identified, the molecular mechanisms underlying calcium signaling remain to be fully explored. As plant mitogen-activated protein kinase (MAPK) cascades are also key components in stress signaling, the interplays between calcium and MAPK signaling pathways require future investigation (details on some of these aspects have also been presented in Chapter 7 of this book). The interaction observed between the MAPK phosphatase NtMKP1 and a CaM suggests cross-talks between Ca<sup>2+</sup>-dependent and Ca<sup>2+</sup>-independent transduction pathways (Yamakawa et al. 2004). Thus, calcium and its sensors appear to be crucial nodes in the stress signaling networks that are essential in cross-tolerance, which increases plant survival under unfavorable conditions.

#### Acknowledgements

This research has been supported by a Marie Curie International fellowship within the sixth European Community Framework Program to M.B. and by an NSF grant (MCB-0446109) to J.S. We apologize to colleagues whose work was not discussed because of space limitations.

#### References

- Abbasi F, Onodera H, Toki S, Tanaka H, Komatsu S (2004) OsCDPK13, a calcium-dependent protein kinase gene from rice, is induced by cold and gibberellin in rice leaf sheath. *Plant Mol Biol* 55:541–552
- Albrecht V, Weigl S, Blazevic D, D'Angelo C, Batistic O, Kolukisaoglu U, Bock R, Schulz B, Harter K, Kudla J (2003) The calcium sensor CBL1 integrates plant responses to abiotic stresses. *Plant J* 36:457–470
- Allen GJ, Kwak JM, Chu SP, Llopis J, Tsien RY, Harper JF, Schroeder JI (1999) Cameleon calcium indicator reports

- cytoplasmic calcium dynamics in *Arabidopsis* guard cells. *Plant J* 19:735–747
- Allen GJ, Chu SP, Schumacher K, Shimazaki CT, Vafeados D, Kemper A, Hawke SD, Tallman G, Tsien RY, Harper JF, Chory J, Schroeder JI (2000) Alteration of stimulus-specific guard cell calcium oscillations and stomatal closing in *Arabidopsis det3* mutant. *Science* 289:2338–2342
- Asano T, Tanaka N, Yang G, Hayashi N, Komatsu S (2005) Genome-wide identification of the rice calcium-dependent protein kinase and its closely related kinase gene families: comprehensive analysis of the CDPKs gene family in rice. *Plant Cell Physiol* 46:356–366
- Bargmann BO, Munnik T (2006) The role of phospholipase D in plant stress responses. *Curr Opin Plant Biol* 9:515–522
- Batistic O, Kudla J (2004) Integration and channeling of calcium signaling through the CBL calcium sensor/CIPK protein kinase network. *Planta* 219:915–924
- Berkowitz G, Zhang X, Mercie R, Leng Q, Lawton M (2000) Co-expression of calcium-dependent protein kinase with the inward rectified guard cell  $K^+$  channel KAT1 alters current parameters in *Xenopus laevis* oocytes. *Plant Cell Physiol* 41:785–790
- Bouché N, Yellin A, Snedden WA, Fromm H (2005) Plant-specific calmodulin-binding proteins. *Annu Rev Plant Biol* 56:435–466
- Camoni L, Harper JF, Palmgren MG (1998) 14-3-3 proteins activate a plant calcium-dependent protein kinase (CDPK). *FEBS Lett* 430:381–384
- Cantero A, Barthakur S, Bushart TJ, Chou S, Morgan RO, Fernandez MP, Clark GB, Roux SJ (2006) Expression profiling of the *Arabidopsis* annexin gene family during germination, de-etiolation and abiotic stress. *Plant Physiol Biochem* 44:13–24
- Carpaneto A, Ivashikina N, Levchenko V, Krol E, Jeworutzki E, Zhu JK, Hedrich R (2007) Cold transiently activates calcium-permeable channels in *Arabidopsis* mesophyll cells. *Plant Physiol* 143:487–494
- Catala R, Santos E, Alonso JM, Ecker JR, Martinez-Zapater JM, Salinas J (2003) Mutations in the  $Ca^{2+}/H^+$  transporter CAX1 increase CBF/DREB1 expression and the cold-acclimation response in *Arabidopsis*. *Plant Cell* 15:2940–2951
- Chehab EW, Patharkar OR, Hegeman AD, Taybi T, Cushman JC (2004) Auto-phosphorylation and sub-cellular localization dynamics of a salt- and water deficit-induced calcium-dependent protein kinase from ice plant. *Plant Physiol* 135:1430–1446
- Cheng SH, Willmann MR, Chen HC, Sheen J (2002) Calcium signaling through protein kinases: The *Arabidopsis* calcium-dependent protein kinase gene family. *Plant Physiol* 129:469–485
- Cheong YH, Kim KN, Pandey GK, Gupta R, Grant JJ, Luan S (2003) CBL1, a calcium sensor that differentially regulates salt, drought, and cold responses in *Arabidopsis*. *Plant Cell* 15:1833–1845
- Cheong YH, Pandey GK, Grant JJ, Batistic O, Li L, Kim BG, Lee SC, Kudla J, Luan S (2007) Two calcineurin B-like calcium sensors, interacting with protein kinase CIPK23, regulate leaf transpiration and root potassium uptake in *Arabidopsis*. *Plant J* 52:223–239
- Choi HI, Park HJ, Park JH, Kim S, Im MY, Seo HH, Kim YW, Hwang I, Kim SY (2005a) *Arabidopsis* calcium-dependent protein kinase AtCPK32 interacts with ABF4, a transcriptional regulator of abscisic acid-responsive gene expression, and modulates its activity. *Plant Physiol* 139:1750–1761
- Choi MS, Kim MC, Yoo JH, Moon BC, Koo SC, Park BO, Lee JH, Koo YD, Han HJ, Lee SY, Chung WS, Lim CO, Cho MJ (2005b) Isolation of a calmodulin-binding transcription factor from rice (*Oryza sativa* L.). *J Biol Chem* 280:40820–40831
- D'Angelo C, Weinl S, Batistic O, Pandey GK, Cheong YH, Schültke S, Albrecht V, Ehlert B, Schulz B, Harter K, Luan S, Bock R, Kudla J (2006) Alternative complex formation of the  $Ca^{2+}$ -regulated protein kinase CIPK1 controls abscisic acid-dependent and independent stress responses in *Arabidopsis*. *Plant J* 48:857–872
- Dammann C, Ichida A, Hong B, Romanowsky SM, Hrabak EM, Harmon AC, Pickard BG, Harper JF (2003) Sub-cellular targeting of nine calcium-dependent protein kinase isoforms from *Arabidopsis*. *Plant Physiol* 132:1840–1848
- Dominguez DC (2004) Calcium signalling in bacteria. *Mol Microbiol* 54:291–297
- Geisler M, Frangne N, Gomes E, Martinoia E, Palmgren MG (2000) The ACA4 gene of *Arabidopsis* encodes a vacuolar membrane calcium pump that improves salt tolerance in yeast. *Plant Physiol* 124:1814–1827
- Gleason C, Chaudhuri S, Yang T, Munoz A, Poovaiah BW, Oldroyd GE (2006) Nodulation independent of rhizobia induced by a calcium-activated kinase lacking auto-inhibition. *Nature* 441:1149–1152
- Gong D, Guo Y, Schumaker KS, Zhu JK (2004) The SOS3 family of calcium sensors and SOS2 family of protein kinases in *Arabidopsis*. *Plant Physiol* 134:919–926
- Gong M, van der Luit AH, Knight MR, Trewavas AJ (1998) Heat-shock-induced changes in intracellular  $Ca^{2+}$  level in tobacco seedlings in relation to thermo-tolerance. *Plant Physiol* 116:429–437
- Guo Y, Xiong L, Song CP, Gong D, Halfter U, Zhu JK (2002) A calcium sensor and its interacting protein kinase are global regulators of abscisic acid signaling in *Arabidopsis*. *Dev Cell* 3:233–244
- Harper JF, Breton G, Harmon A (2004) Decoding  $Ca^{2+}$  signals through plant protein kinases. *Annu Rev Plant Biol* 55:263–288
- Hegeman AD, Rodriguez M, Han BW, Uno Y, Phillips GN, Hrabak EM, Cushman JC, Harper JF, Harmon AC, Sussman MR (2006) A phyloproteomic characterization of in vitro autophosphorylation in calcium-dependent protein kinases. *Proteomics* 6:3649–3664

- Hepler PK (2005) Calcium: a central regulator of plant growth and development. *Plant Cell* 17:2142–2155
- Hetherington AM, Brownlee C (2004) The generation of  $\text{Ca}^{2+}$  signals in plants. *Annu Rev Plant Biol* 55:401–427
- Hirschi KD (1999) Expression of *Arabidopsis* CAX1 in tobacco: altered calcium homeostasis and increased stress sensitivity. *Plant Cell* 11:2113–2122
- Hrabak EM, Chan CWM, Gribskov M, Harper JF, Choi JH, Halford N, Kudla J, Luan S, Nimmo HG, Sussman MR, Thomas M, Walker Simmons K, Zhu JK, Harmon AC (2003) The *Arabidopsis* CDPK-SnRK superfamily of protein kinases. *Plant Physiol* 132:666–680
- Hua W, Li RJ, Wang L, Lu YT (2004) A tobacco calmodulin-binding protein kinase (NtCBK2) induced by high-salt/GA treatment and its expression during floral development and embryogenesis. *Plant Sci* 166:1253–1259
- Hwang I, Sze H, Harper JF (2000) A calcium-dependent protein kinase can inhibit a calmodulin-stimulated  $\text{Ca}^{2+}$  pump (ACA2) located in the endoplasmic reticulum of *Arabidopsis*. *Proc Natl Acad Sci USA* 97:6224–6229
- Ishitani M, Liu J, Halfter U, Kim CS, Shi W, Zhu JK (2000) SOS3 function in plant salt tolerance requires N-myristoylation and calcium binding. *Plant Cell* 12:1667–1678
- Johansson I, Larsson C, Ek B, Kjellbom P (1996) The major integral proteins of spinach leaf plasma membranes are putative aquaporins and are phosphorylated in response to  $\text{Ca}^{2+}$  and apoplastic water potential. *Plant Cell* 8:1181–1191
- Kaplan B, Davydov O, Knight H, Galon Y, Knight MR, Fluhr R, Fromm H (2006) Rapid transcriptome changes induced by cytosolic  $\text{Ca}^{2+}$  transients reveal ABRE-related sequences as  $\text{Ca}^{2+}$ -responsive cis elements in *Arabidopsis*. *Plant Cell* 18:2733–2748
- Kiegle E, Moore CA, Haseloff J, Tester MA, Knight MR (2000) Cell-type-specific calcium responses to drought, salt and cold in the *Arabidopsis* root. *Plant J* 23:267–278
- Kim J, Kim HY (2006) Functional analysis of a calcium-binding transcription factor involved in plant salt stress signaling. *FEBS Lett* 580:5251–5256
- Kim KN, Cheong YH, Grant JJ, Pandey GK, Luan S (2003) CIPK3, a calcium sensor-associated protein kinase that regulates abscisic acid and cold signal transduction in *Arabidopsis*. *Plant Cell* 15:411–423
- Kim SA, Kwak JM, Jae SK, Wang MH, Nam HG (2001) Over-expression of the AtGluR2 gene encoding an *Arabidopsis* homolog of mammalian glutamate receptors impairs calcium utilization and sensitivity to ionic stress in transgenic plants. *Plant Cell Physiol* 42:74–84
- Knight MR, Campbell AK, Smith SM, Trewavas AJ (1991) Transgenic plant aequorin reports the effects of touch and cold-shock and elicitors on cytoplasmic calcium. *Nature* 352:524–526
- Kolkisaoglu U, Weigl S, Blazevic D, Batistic O, Kudla J (2004) Calcium sensors and their interacting protein kinases: genomics of the *Arabidopsis* and rice CBL-CIPK signaling networks. *Plant Physiol* 134:43–58
- Lee JY, Yoo BC, Harmon AC (1998) Kinetic and calcium-binding properties of three calcium-dependent protein kinase isoenzymes from soybean. *Biochemistry* 37:6801–6809
- Lee S, Lee EJ, Yang EJ, Lee JE, Park AR, Song WH, Park OK (2004) Proteomic identification of annexins, calcium-dependent membrane binding proteins that mediate osmotic stress and abscisic acid signal transduction in *Arabidopsis*. *Plant Cell* 16:1378–1391
- Lee SH, Kim MC, Heo WD, Kim JC, Chung WS, Park CY, Park HC, Cheong YH, Kim CH, Lee SH, Lee KJ, Bahk JD, Lee SY, Cho MJ (1999) Competitive binding of calmodulin isoforms to calmodulin-binding proteins: implication for the function of calmodulin isoforms in plants. *Biochim Biophys Acta* 1433:56–67
- Lee SH, Johnson JD, Walsh MP, Van Lierop JE, Sutherland C, Xu A, Snedden WA, Kosk-Kosicka D, Fromm H, Narayanan N, Cho MJ (2000) Differential regulation of  $\text{Ca}^{2+}$ /calmodulin-dependent enzymes by plant calmodulin isoforms and free  $\text{Ca}^{2+}$  concentration. *Biochem J* 350:299–306
- Lemtiri-Chlieh F, Berkowitz GA (2004) Cyclic adenosine monophosphate regulates calcium channels in the plasma membrane of *Arabidopsis* leaf guard and mesophyll cells. *J Biol Chem* 279:35306–35312
- Li B, Liu HT, Sun DY, Zhou RG (2004)  $\text{Ca}^{2+}$  and calmodulin modulate DNA-binding activity of maize heat shock transcription factor in vitro. *Plant Cell Physiol* 45:627–634
- Li DF, Li J, Ma L, Zhang L, Lu YT (2006) Calmodulin isoform-specific activation of a rice calmodulin-binding kinase conferred by only three amino-acids of OsCaM61. *FEBS Lett* 580:4325–4331
- Li J, Lee YR, Assmann SM (1998) Guard cells possess a calcium-dependent protein kinase that phosphorylates the KAT1 potassium channel. *Plant Physiol* 116:785–795
- Liu F, Yoo BC, Lee JY, Pan W, Harmon AC (2006) Calcium-regulated phosphorylation of soybean serine acetyltransferase in response to oxidative stress. *J Biol Chem* 281:27405–27415
- Liu HT, Li B, Shang ZL, Li XZ, Mu RL, Sun DY, Zhou RG (2003) Calmodulin is involved in heat shock signal transduction in wheat. *Plant Physiol* 132:1186–1195
- Logan DC, Knight MR (2003) Mitochondrial and cytosolic calcium dynamics are differentially regulated in plants. *Plant Physiol* 133:21–24
- Luan S, Kudla J, Rodriguez Concepcion M, Yalovsky S, Gruissem W (2002) Calmodulins and calcineurin B-like proteins: calcium sensors for specific signal response coupling in plants. *Plant Cell* 14(Suppl. S), S389–S400
- Luoni L, Bonza MC, de Michelis MI (2006) Calmodulin/ $\text{Ca}^{2+}$ -ATPase interaction at the *Arabidopsis thaliana* plasma membrane is dependent on calmodulin isoform showing isoform-specific  $\text{Ca}^{2+}$  dependencies. *Physiol Plant* 126:175–186
- Ma SY, Wu WH (2007) AtCPK23 functions in *Arabidopsis* responses to drought and salt stresses. *Plant Mol Biol* 65(4), 511–518



- Martin ML, Busconi L (2000) Membrane localization of a rice calcium-dependent protein kinase (CDPK) is mediated by myristoylation and palmitoylation. *Plant J* 24:429–435
- Martin ML, Busconi L (2001) A rice membrane-bound calcium-dependent protein kinase is activated in response to low temperature. *Plant Physiol* 125:1442–1449
- McCormack E, Braam J (2003) Calmodulins and related potential calcium sensors of *Arabidopsis*. *New Phytol* 159:585–598
- Mishra G, Zhang W, Deng F, Zhao J, Wang X (2006) A bifurcating pathway directs abscisic acid effects on stomatal closure and opening in *Arabidopsis*. *Science* 312:264–266
- Monroy AF, Sarhan F, Dhindsa RS (1993) Cold-induced changes in freezing tolerance, protein phosphorylation, and gene expression – evidence for a role of calcium. *Plant Physiol* 102:1227–1235
- Mori IC, Murata Y, Yang Y, Munemasa S, Wang YF, Andreoli S, Tiriach H, Alonso JM, Harper JF, Ecker JR, Kwak JM, Schroeder JI (2006) CDPKs CPK6 and CPK3 function in ABA regulation of guard cell S-type anion- and Ca<sup>2+</sup>-permeable channels and stomatal closure. *PLoS Biol* 4:1749–1762
- Nagai M, Nozawa A, Koizumi N, Sano H, Hashimoto H, Sato M, Shimizu T (2003) The crystal structure of the novel calcium-binding protein AtCBL2 from *Arabidopsis thaliana*. *J Biol Chem* 278:42240–42246
- Otterhag L, Sommarin M, Pical C (2001) N-terminal EF-hand-like domain is required for phosphoinositide-specific phospholipase C activity in *Arabidopsis thaliana*. *FEBS Lett* 497:165–170
- Pandey GK, Cheong YH, Kim KN, Grant JJ, Li L, Hung W, D'Angelo C, Weinl S, Kudla J, Luan S (2004) The calcium sensor calcineurin B-like 9 modulates abscisic acid sensitivity and biosynthesis in *Arabidopsis*. *Plant Cell* 16:1912–1924
- Pandey S, Tiwari SB, Tyagi W, Reddy MK, Upadhyaya KC, Sopory SK (2002) A Ca<sup>2+</sup>/CaM-dependent kinase from pea is stress regulated and in vitro phosphorylates a protein that binds to AtCaM5 promoter. *Eur J Biochem* 269:3193–3204
- Patharkar OR, Cushman JC (2000) A stress-induced calcium-dependent protein kinase from *Mesembryanthemum crystallinum* phosphorylates a two-component pseudo-response regulator. *Plant J* 24:679–691
- Pauly N, Knight MR, Thuleau P, van der Luit AH, Moreau M, Trewavas AJ, Ranjeva R, Mazars C (2000) Control of free calcium in plant cell nuclei. *Nature* 405:754–755
- Pauly N, Knight MR, Thuleau P, Graziana A, Muto S, Ranjeva R, Mazars C (2001) The nucleus together with the cytosol generates patterns of specific cellular calcium signatures in tobacco suspension culture cells. *Cell Calcium* 30:413–421
- Pei ZM, Ward JM, Harper JF, Schroeder JI (1996) A novel chloride channel in *Vicia faba* guard cell vacuoles activated by the serine/threonine kinase, CDPK. *EMBO J* 15:6564–6574
- Peiter E, Maathuis FJ, Mills LN, Knight H, Pelloux J, Hetherington AM, Sanders D (2005) The vacuolar Ca<sup>2+</sup>-activated channel TPC1 regulates germination and stomatal movement. *Nature* 434:404–408
- Perruc E, Charpentreau M, Ramirez BC, Jauneau A, Galaud JP, Ranjeva R, Ranty B (2004) A novel calmodulin-binding protein functions as a negative regulator of osmotic stress tolerance in *Arabidopsis thaliana* seedlings. *Plant J* 38:410–420
- Popescu SC, Popescu GV, Bachan S, Zhang Z, Seay M, Gerstein M, Snyder M, Dinesh-Kumar SP (2007) Differential binding of calmodulin-related proteins to their targets revealed through high-density *Arabidopsis* protein microarrays. *Proc Natl Acad Sci USA* 104:4730–4735
- Price AH, Taylor A, Ripley SJ, Griffiths A, Trewavas AJ, Knight MR (1994) Oxidative signals in tobacco increase cytosolic calcium. *Plant Cell* 6:1301–1310
- Qi Z, Stephens NR, Spalding EP (2006) Calcium entry mediated by GLR3.3, an *Arabidopsis* glutamate receptor with a broad agonist profile. *Plant Physiol* 142:963–971
- Quan R, Lin H, Mendoza I, Zhang Y, Cao W, Yang Y, Shang M, Chen S, Pardo JM, Guo Y (2007) SCABP8/CBL10, a putative calcium sensor, interacts with the protein kinase SOS2 to protect *Arabidopsis* shoots from salt stress. *Plant Cell* 19:1415–1431
- Raichaudhuri A, Bhattacharyya R, Chaudhuri S, Dasgupta M (2006) Domain analysis of a groundnut calcium-dependent protein kinase: nuclear localization sequence in the junction domain is coupled with nonconsensus calcium binding domains. *J Biol Chem* 281:10399–10409
- Reddy VS, Reddy ASN (2004) Proteomics of calcium-signaling components in plants. *Phytochemistry* 65:1745–1776
- Roberts DM, Rowe PM, Siegel FL, Lukas TJ, Watterson DM (1986) Trimethyllysine and protein function. Effect of methylation and mutagenesis of lysine 115 of calmodulin on NAD kinase activation. *J Biol Chem* 261:1491–1494
- Rodriguez Milla MA, Uno Y, Chang IF, Townsend J, Maher EA, Quilici D, Cushman JC (2006) A novel yeast two-hybrid approach to identify CDPK substrates: characterization of the interaction between AtCPK11 and AtDi19, a nuclear zinc finger protein. *FEBS Lett* 580:904–911
- Saijo Y, Hata S, Kyojuka J, Shimamoto K, Izui K (2000) Over-expression of a single Ca<sup>2+</sup>-dependent protein kinase confers both cold and salt/drought tolerance on rice plants. *Plant J* 23:319–327
- Sanchez-Barrena MJ, Martinez-Ripoll M, Zhu JK, Albert A (2005) The structure of the *Arabidopsis thaliana* SOS3: molecular mechanism of sensing calcium for salt stress response. *J Mol Biol* 345:1253–1264
- Sanders D, Pelloux J, Brownlee C, Harper JF (2002) Calcium at the crossroads of signaling. *Plant Cell* 14(Suppl S), S401–S417
- Sathyanarayanan PV, Poovaiah BW (2004) Decoding Ca<sup>2+</sup> signals in plants. *Crit Rev Plant Sci* 23:1–11
- Scruse-Field SA, Knight MR (2003) Calcium: just a chemical switch? *Curr Opin Plant Biol* 6:500–506

- Shao J, Harmon AC (2003) In vivo phosphorylation of a recombinant peptide substrate of CDPK suggests involvement of CDPK in plant stress responses. *Plant Mol Biol* 53:691–700
- Sheen J (1996) Ca<sup>2+</sup>-dependent protein kinases and stress signal transduction in plants. *Science* 274:1900–1902
- Song CP, Agarwal M, Ohta M, Guo Y, Halfter U, Wang P, Zhu JK (2005) Role of an *Arabidopsis* AP2/EREBP-type transcriptional repressor in abscisic acid and drought stress responses. *Plant Cell* 17:2384–2396
- Subbaiah CC, Bush DS, Sachs MM (1998) Mitochondrial contribution to the anoxic Ca<sup>2+</sup> signal in maize suspension-cultured cells. *Plant Physiol* 118:759–771
- Sze H, Liang F, Hwang I, Curran AC, Harper JF (2000) Diversity and regulation of plant Ca<sup>2+</sup> pumps: insights from expression in yeast. *Annu Rev Plant Mol Plant Physiol* 51:433–462
- Tang RH, Han S, Zheng H, Cook CW, Choi CS, Woerner TE, Jackson RB, Pei ZM (2007) Coupling diurnal cytosolic Ca<sup>2+</sup> oscillations to the CAS-IP<sub>3</sub> pathway in *Arabidopsis*. *Science* 315:1423–1426
- Townley HE, Knight MR (2002) Calmodulin as a potential negative regulator of *Arabidopsis* *COR* gene expression. *Plant Physiol* 128:1169–1172
- van der Luit AH, Olivari C, Haley A, Knight MR, Trewavas AJ (1999) Distinct calcium signaling pathways regulate calmodulin gene expression in tobacco. *Plant Physiol* 121:705–714
- Wan B, Lin Y, Mou T (2007) Expression of rice Ca<sup>2+</sup>-dependent protein kinases (CDPKs) genes under different environmental stresses. *FEBS Lett* 581:1179–1189
- White PJ, Broadley MR (2003) Calcium in plants. *Ann Bot* 92:487–511
- Wood NT, Allan AC, Haley A, Viry-Moussaid M, Trewavas AJ (2000) The characterization of differential calcium signalling in tobacco guard cells. *Plant J* 24:335–344
- Wu Y, Kuzma J, Marechal E, Graeff R, Lee HC, Foster R, Chua NH (1997) Abscisic acid signaling through cyclic ADP-ribose in plants. *Science* 278:2126–2130
- Xiong LM, Schumaker KS, Zhu JK (2002) Cell signaling during cold, drought and salt stress. *Plant Cell* 14(Suppl S), S165–S183
- Yamakawa H, Katou S, Seo S, Mitsuhashi I, Kamada H, Ohashi Y (2004) Plant MAPK phosphatase interacts with calmodulins. *J Biol Chem* 279:928–936
- Yamniuk AP, Vogel HJ (2005) Structural investigation into the differential target enzyme regulation displayed by plant calmodulin isoforms. *Biochemistry* 44:3101–3111
- Yang T, Poovaiah BW (2002) Hydrogen peroxide homeostasis: activation of plant catalase by calcium/calmodulin. *Proc Natl Acad Sci USA* 99:4097–4102
- Yang T, Poovaiah BW (2003) Calcium/calmodulin-mediated signal network in plants. *Trends Plant Sci* 8:505–512
- Yoo JH, Park CY, Kim JC, Heo WD, Cheong MS, Park HC, Kim MC, Moon BC, Choi MS, Kang YH, Lee JH, Kim HS, Lee SM, Yoon HW, Lim CO, Yun DJ, Lee SY, Chung WS, Cho MJ (2005) Direct interaction of a divergent CaM isoform and the transcription factor, MYB2, enhances salt tolerance in *Arabidopsis*. *J Biol Chem* 280:3697–3706
- Yu XC, Li MJ, Gao GF, Feng HZ, Geng XQ, Peng CC, Zhu SY, Wang XJ, Shen YY, Zhang DP (2006) Abscisic acid stimulates a calcium-dependent protein kinase in grape berry. *Plant Physiol* 140:558–579
- Yu XC, Zhu SY, Gao GF, Wang XJ, Zhao R, Zou KQ, Wang XF, Zhang XY, Wu FQ, Peng CC, Zhang DP (2007) Expression of a grape calcium-dependent protein kinase ACPK1 in *Arabidopsis thaliana* promotes plant growth and confers abscisic acid-hypersensitivity in germination, post-germination growth, and stomatal movement. *Plant Mol Biol* 64:531–538

## Stress Signaling III: Reactive Oxygen Species (ROS)

Mikael Brosché<sup>#</sup>, Kirk Overmyer<sup>#</sup>, Michael Wrzaczek<sup>#</sup>,  
and Jaakko Kangasjärvi<sup>\*</sup>

*Plant Biology, Department of Biological and Environmental Sciences,  
University of Helsinki, FI-00014, Helsinki, Finland*

Sajjaliisa Kangasjärvi<sup>#</sup>

*Plant Physiology and Molecular Biology, Department of Biology,  
University of Turku, FI-20014, Turku, Finland*

Summary .....	91
I Introduction .....	92
II ROS Production and Control.....	92
A The Cytosol and ROS Movement.....	92
B Chloroplasts and Photosynthesis.....	93
C Peroxisomes and Photorespiration .....	93
D Mitochondrial Respiration.....	94
E Apoplastic ROS Production.....	94
F Antioxidant Regulation.....	94
III The Perception of ROS .....	95
A Redox Regulation and ROS Perception .....	95
B ROS Downstream Signaling Networks.....	97
IV Insights from Genetic and Genomic Strategies.....	97
A Genomics and Microarrays.....	97
B Transgenic Approaches .....	98
C <sup>1</sup> O <sub>2</sub> Signal Transduction.....	99
V Conclusions.....	99
Acknowledgements .....	99
References .....	100

### Summary

Previously regarded merely as damaging agents, reactive oxygen species (ROS) are now understood as important signal molecules vital to normal plant growth. This tutorial review covers the emerging view of ROS signaling networks from ROS production to specific outputs. The chemical nature of individual reactive oxygen species, their site of the production, control of ROS accumulation via scavenging and detoxification, and the signaling components that interact with ROS are all inputs that are integrated to produce a specific response. ROS perception in plants remains largely undefined. However, a few mechanisms known in plants or suggested in other organisms are discussed. Using genetic and genomic tools, some of the components involved in ROS signal transduction have begun to be delineated.

---

\*Author for correspondence, e-mail: jaakko.kangasjarvi@helsinki.fi

<sup>#</sup>Equal contribution

Transcript profiling in the model plant *Arabidopsis thaliana* has revealed that ROS has a large impact on the transcriptome, and that different ROS species can have common, distinct or even negative interference with each other in regulating gene expression.

Keywords Hydrogen peroxide • ozone • perception • redox regulation • ROS crosstalk • signal transduction

## I Introduction

The production of reactive oxygen species (ROS) is a unifying commonality in a large number of abiotic stresses. For example, the air pollutant ozone reacts with cellular components in the leaf apoplast to produce ROS, which in turn induce the active production of ROS by the plant cell itself, termed as an “oxidative burst”. Plants constantly encounter variations in environmental conditions leading to variations in the availability of nutrients and water, which may lead to formation of ROS in different cellular compartments. For example, a combination of high light and cold may imbalance photosynthetic processes and induce ROS formation in chloroplasts.

ROS include superoxide ( $\text{O}_2^-$ ), hydrogen peroxide ( $\text{H}_2\text{O}_2$ ), hydroxyl radical (OH), singlet oxygen ( $^1\text{O}_2$ ) and the air pollutant ozone ( $\text{O}_3$ ). One type of ROS can be converted into another type, for example,  $\text{O}_3$  breaks down to  $\text{H}_2\text{O}_2$ ,  $\text{O}_2^-$ , and  $^1\text{O}_2$ .  $\text{O}_2^-$  is either spontaneously or enzymatically dismutated to  $\text{H}_2\text{O}_2$  via SOD activity (Foyer et al. 1997) rapidly, which may further react with  $\text{Fe}^{2+}$  to form highly reactive  $\text{OH}$ . The co-accumulation

of  $\text{H}_2\text{O}_2$  and  $\text{O}_2^-$  also promotes  $\text{OH}$  production (Apel and Hirt 2004; Mittler et al. 2004).

The chemical properties and the location of ROS production are important with respect to cellular responses to ROS accumulation (Apel and Hirt 2004). Indeed, not all ROS are equal and each ROS leaves a unique “oxidative footprint” in the cell. The chemical nature of individual reactive oxygen species, their site of production, control of ROS accumulation via scavenging and detoxification, and the signaling components that interact with ROS are all inputs that are integrated to produce a specific response. For example,  $\text{OH}$  readily reacts with all types of cellular components,  $\text{O}_2^-$  reacts primarily with protein Fe-S centers, and  $^1\text{O}_2$  is particularly reactive with double bonds of polyunsaturated fatty acids (Moller et al. 2007).

Given their highly reactive nature, most ROS do not move very far and are likely to react where they are produced. Thus, in most cases the site of production will determine the site of action. Exceptionally,  $\text{H}_2\text{O}_2$  is more stable and capable of long distance diffusion and, in contrast to other types of ROS, capable of crossing membranes. Previously thought to be purely damaging agents due to their presence during stress, ROS are now understood rather as important signaling molecules vital for plant growth and development. Indeed, with this understanding a new concept of oxidative signaling in plants has emerged (Buchanan and Balmer 2005; Foyer and Noctor 2005). The emerging picture of how plants accomplish this is explored in the following pages.

## II ROS Production and Control

### A The Cytosol and ROS Movement

In contrast to copious information concerning ROS production in other sub-cellular compartments, a survey of literature reveals a surprising lack of information on cytosolic ROS production.

---

*Abbreviations:*  $^1\text{O}_2$  singlet oxygen; ABA – abscisic acid; AOX – alternative oxidase; APX – ascorbate peroxidase; AsA – ascorbic acid; CAT – catalase; CRY1 – cryptochrome 1; DHA – dehydroascorbic acid; GPX – glutathione peroxidase; GR – glutathione reductase; GSH – glutathione (reduced); GSSG – glutathione (oxidized);  $\text{H}_2\text{O}_2$  – hydrogen peroxide; HSP – heat shock protein; JA – jasmonic acid; LOX – lipoxygenase; MV – methyl viologen (paraquat); MAPK – mitogen-activated protein kinase; MDHA – monodehydroascorbic acid; OH – hydroxyl radical;  $\text{O}_2^-$  – superoxide;  $\text{O}_3$  – ozone; PCD – programmed cell death; PM – plasma membrane; PP2C – protein phosphatase 2C; PRX – peroxiredoxin; PS I – Photosystem I; PS II – Photosystem II; RBOHs – respiratory burst oxidase homologs; ROS – reactive oxygen species; Rubisco – ribulose-1,5-bisphosphate carboxylase/oxygenase; SAsalicylic acid; SAR – systemic acquired resistance; SOD – superoxide dismutase; TRXthioredoxin



It seems that there is no major direct source of ROS production in the cytosol. However, there is  $H_2O_2$  movement between the cytosol and other compartments, where they are produced (Fig. 1). This movement, previously assumed to be passive diffusion, is facilitated by  $H_2O_2$  specific aquaporins (Bienert et al. 2007). Also, the cytosol is the site of signals regulating apoplastic ROS production on the PM. Thus, the cytosol integrates and transmits ROS signals emanating to and from other compartments.

### B Chloroplasts and Photosynthesis

Photosynthetic electron transfer reactions comprise a significant source of ROS due to formation of highly oxidizing intermediates in light-exposed green tissues. Light stress occurs when photosynthetic light harvesting exceeds the capacity of photosynthetic carbon metabolism, and the photosynthetic electron transfer chain becomes reduced. This in turn promotes enhanced ROS formation and photo-oxidative stress in chloroplasts. In the reaction center of photosystem II (PS II),  $^1O_2$  is formed via energy transfer reactions between excited triplet

chlorophylls and  $O_2$ . This inevitable property of PS II redox chemistry occurs constantly even under relatively low illumination levels and is substantially enhanced under high irradiance levels (Aro et al. 2005; Hideg et al. 2002). Molecular oxygen may also act as an alternative electron acceptor for Photosystem I (PSI), which results in formation of  $^{\cdot}O_2^-$  and  $H_2O_2$  on the stromal side of the thylakoid membrane (Asada 1999).

Accumulation of phototoxic chlorophyll biosynthesis intermediates or degradation products may lead to the generation of ROS in chloroplasts, for example, in the *Arabidopsis* mutant *fluorescent* (*flu*). Also, deficiency in chlorophyllase-1 caused enhanced  $H_2O_2$  production and high-light sensitivity in *Arabidopsis* (Kariola et al. 2005).

### C Peroxisomes and Photorespiration

Photorespiration consumes excess photosynthetic reducing energy and thus alleviates chloroplastic ROS production, at the expense of producing ROS in peroxisomes (Corpas et al. 2001). When carbon metabolism becomes limiting for photosynthesis, the oxygenase activity of Rubisco increases

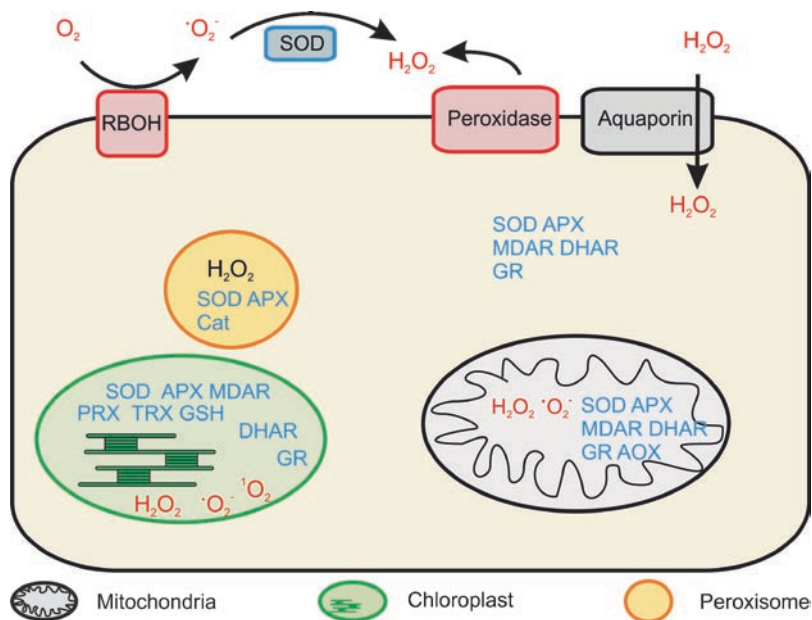

Fig. 1. Sites of reactive oxygen species (ROS) production and enzymatic ROS scavengers. Scavengers are indicated by grey letters. Abbreviations: SOD – superoxide dismutase; APX – ascorbate peroxidase; MDAR – monodehydroascorbate reductase; DHAR – dehydroascorbate reductase; GR – glutathione reductase; CAT – catalase; AOX – alternative oxidase; PRX – peroxiredoxin; TRX – thioredoxin [See Color Plate 2, Fig. 4].

and the resulting glycolate is translocated into peroxisomes and oxidized by glycolate oxidase, producing  $\text{H}_2\text{O}_2$ .

#### D Mitochondrial Respiration

Mitochondria, a major source of ROS in mammalian, yeast and plant cells (Noctor et al. 2007), produce ROS by transfer of electrons to  $\text{O}_2$  at several steps of the electron transport chain. Mitochondria are particularly sensitive to damage by oxidative stress (Bartoli et al. 2004), which can trigger further ROS production and amplify ROS signals. Plant mitochondrial respiration is tightly connected with photosynthetic processes. During photo-oxidative stress and photorespiration, a higher flux of electrons traverses the mitochondrial respiratory chain. This enhances the risk of ROS production and necessitates a bypass of the electron transport chain. Several plant-specific alternative electron or proton transfer components perform this function; such as NADPH dehydrogenases, the uncoupling protein complex (Sweetlove et al. 2006) and alternative oxidase (AOX). These mechanisms bypass in part the electron transport chain, uncoupling electron flow from ATP synthesis while allowing the reduction of  $\cdot\text{O}_2$  to water (Maxwell et al. 1999; Sweetlove et al. 2006).

#### E Apoplastic ROS Production

Many mechanisms have been suggested as a source of extracellular ROS. However, the PM-associated NADPH oxidases, or respiratory burst oxidase homologs (RBOHs), are the most-studied ROS source during stress. Plant NADPH oxidases are multi-protein complexes composed of regulatory subunits and a membrane associated catalytic subunit, which is responsible for the synthesis of  $\cdot\text{O}_2^-$  in the apoplast. Several studies have shown a role of small GTPases in the regulation of ROS production via RBOHs. Expression of a dominant negative mutant of rice RAC1 in tobacco compromised ROS accumulation and multiple forms of pathogen resistance. The related rho family of GTPases, in plants termed ROPs (rho of plants), are also positive regulators of RBOH derived ROS in pathogen responses (Agrawal et al. 2003). Significantly, *Arabidopsis* RopGAP4, a regulator of ROPs, is involved in regulation of  $\text{H}_2\text{O}_2$  production and defenses in anoxia (Baxter-Burrell et al. 2002).

Although first discovered for their role in immunity and cell death, plant RBOHs are involved in abiotic stresses as well (Torres and Dangel 2005). *Arabidopsis RbohD* and *-F* have been implicated in ABA signal transduction especially in stomatal closure (Kwak et al. 2003). Reducing RBOH activity with inhibitors in transgenic plants (or mutants) has shown their contribution to ROS production and resulting defense responses, for example, in tomato, RBOH-derived ROS are required for wound responsive gene-expression (Sagi et al. 2004); while in *Arabidopsis* the *atrbohB* and *-D* mutants exhibited increased sensitivity to heat stress (Larkindale et al. 2005) and exposure to UV-B radiation induced NADPH oxidase activity (Rao and Ormrod 1995). Inhibitor experiments suggested that RBOHs were a source of  $\text{O}_3$ -induced ROS (Overmyer et al. 2003), which was confirmed genetically as *rboh* mutants show reduced  $\text{O}_3$ -induced ROS accumulation and, in some cases reduced  $\text{O}_3$ -induced cell death (Joo et al. 2005).

#### F Antioxidant Regulation

In addition to production, ROS scavenging and detoxification are critical to the control of ROS accumulation and thus the perpetuation or attenuation of ROS signals. Plants have evolved versatile antioxidant systems to ensure tightly regulated ROS levels (Fig. 1). The details of this system are only incompletely handled here, as required to illustrate some of the complexity of ROS signaling control. For more information on these systems consult these excellent reviews (Apel and Hirt 2004; Foyer and Noctor 2005). Components of this system include enzymatic antioxidants (SOD, APX, PRX, GPX, CAT, GRX and TRX) and non-enzymatic scavengers (AsA, GSH, tocopherols, carotenoids and phenolic compounds). GSH, which is oxidized to GSSG, and AsA, which is oxidized to MDHA and DHA constitute the main cellular redox buffers. The various antioxidant agents possess partially overlapping functions, and can functionally compensate for each other. Such functional redundancy was demonstrated, for example, by the upregulation of AsA and GSH levels in tocopherol deficient plants (Kanwischer et al. 2005).

SODs are classified according to their metal co-factor: Cu/ZnSOD, FeSOD and MnSOD and reside in specific sub-cellular compartments

(Mittler et al. 2004). SOD dismutates  $\text{O}_2^-$  into  $\text{H}_2\text{O}_2$ , which is in turn detoxified by APX, PRX, GPX or CAT. APX is dependent on the AsA/GSH cycle, known as the Halliwell-Asada-Foyer cycle which shuttles reducing equivalents from NADPH via GSH to regenerate reduced AsA (Foyer and Noctor 2005). APX isoforms are targeted to cytoplasm, chloroplasts, mitochondria, peroxisomes, glyoxisomes and the ER.

PRXs detoxify peroxides through a thiol-based mechanism and are also involved in signaling. Regeneration of oxidized PRX occurs via the action of various thioredoxins, glutaredoxins and thioredoxin-like proteins (Dietz et al. 2006). Also GPXs, a functionally related group of  $\text{H}_2\text{O}_2$ -detoxifying enzymes, utilize thioredoxins as reducing agents (Iqbal et al. 2006). CAT, a tetrameric iron porphyrin protein located mainly in the peroxisomes, detoxifies  $\text{H}_2\text{O}_2$  into water and  $\text{O}_2$  (Apel and Hirt 2004).

### III The Perception of ROS

#### A Redox Regulation and ROS Perception

ROS perception in plants remains largely undefined. However, the fact that plant cells sense ROS with regard to type, location and amount indicates that sophisticated mechanisms exist that gather and process information about the current ROS and/or antioxidant status and initiate the required changes in transcription, protein expression and metabolism (Table 1). In most cases the direct biochemical means of ROS-perception remain

unknown. However, a few mechanisms are known or suggested, in some cases in other systems.

$\text{H}_2\text{O}_2$  is a mild oxidant, and may thus exert its signaling effects via oxidation of regulatory dithiol groups in signaling proteins (Moller et al. 2007). In mammals, for example, the  $\alpha$ -subunit of heterotrimeric G-proteins  $\text{G}\alpha_i$  and  $\text{G}\alpha_o$  can be directly modified by ROS. The modification of cysteine residues appears to be a requirement of the activation mechanism (Feng et al. 2000). The examples of  $\text{H}_2\text{O}_2$ -mediated modulation of regulatory enzymes in plants include restoration of LHCII kinase activity in vitro (Martinsuo et al. 2003), and  $\text{H}_2\text{O}_2$ -induced conformational changes in small HSPs (Harndahl et al. 1999) in chloroplasts. Similarly, the reversible modulation of ABI2, a protein phosphatase 2C, activity by  $\text{H}_2\text{O}_2$  appears to be important in ABA signaling in guard cells (Meinhard et al. 2002).

In yeast, the Yap1 oxidative stress pathway is an example of redox regulation of a transcription factor (Mason et al. 2006). In plants, an example of ROS perception where transcription factors are involved is the *Arabidopsis* SA signaling protein NPR1 (Despres et al. 2003) which confers redox regulation of DNA binding activity to the transcription factor TGA1. SA promotes ROS accumulation and indirectly induces the reduction of cysteine residues in TGA1. The redox status change does not directly influence the DNA binding activity of TGA1, but interaction with NPR1 enhances the DNA binding of the reduced form of TGA1. NPR1 itself forms cytosolic aggregates held together by intermolecular disulphide bridges. SA enhanced ROS causes relocation of active NPR1 monomers to the nucleus (Fig. 2a).

Table 1. Reactive oxygen species (ROS) perception mechanisms.

Perception Component	Evidence	Mechanism
Protein oxidation	Experimental evidence (e.g., NPR1, TGA1, phosphatases, proteasome, transcription factors)	Protein oxidation could lead to changes in protein localization, stability, enzymatic activity and protein-protein interaction
Lipid peroxidation	Experimental evidence	Oxylipins could be directly toxic or could function as signals
Interaction of proteins with ROS scavengers	Experimental evidence (NDK1 - CAT, TRX)	Activation or inactivation of ROS scavengers may amplify or reduce the ROS signal
Sensing of the cellular REDOX status	Indirect experimental evidence	Some mutants with altered REDOX balance display constitutive expression of defense genes

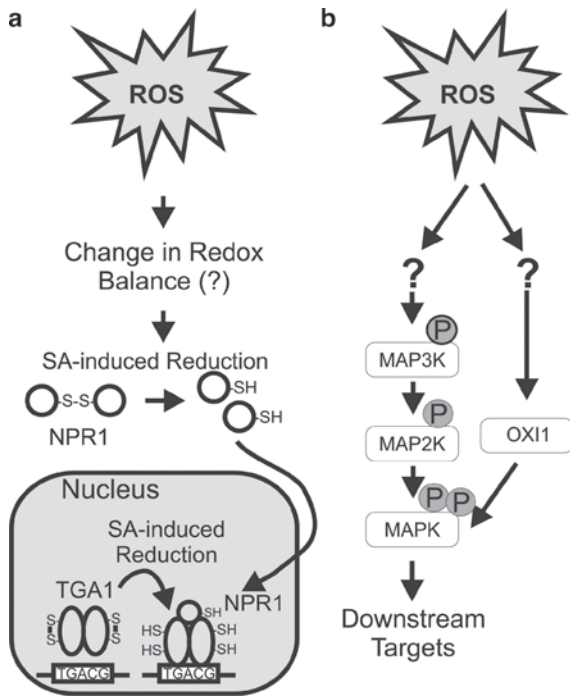

Fig. 2. Examples of reactive oxygen species (ROS) signalling. (a) PR1/TGA1 signalling. ROS-induced SA production causes the reduction of NPR1 and TGA1 to allow complex formation and DNA binding of the proteins. The encircled P indicates phosphorylation events; (b) MAPK signaling pathway. Phosphorylation cascade leads to transcriptional change and subsequently to stress response.

Paradoxically, the reduction of TGA1 and NPR1 occur under oxidative conditions. The TGA1/NPR1 system might be similar to the yeast YAP1 system, which shows a similar mechanism (Despres et al. 2003).

Recently an intriguing idea has emerged; heat shock transcription factors (HSF) could function as  $H_2O_2$  sensors. A promoter element found in many  $H_2O_2$  responsive promoters is the heat shock element (Miller and Mittler 2006). Significantly, several genes in *Arabidopsis* are coregulated by heat stress and  $H_2O_2$  (Vanderauwera et al. 2005). One interpretation of these results is that heat shock induces  $H_2O_2$  as a signaling intermediate. However, in yeast,  $O_2^-$  directly causes a conformational change in the HSFs to the high-activity trimeric form. Similarly, human HSF1 and *Drosophila* HSF sense  $H_2O_2$  and form active trimers in a reversible and redox dependent manner (Miller and Mittler 2006). *In planta* evidence for this hypothesis comes from over-expression of a dominant

negative *Arabidopsis* HSF21 which blocked the expression of some  $H_2O_2$  regulated genes (Davletova et al. 2005a; Miller and Mittler 2006).

In addition to direct ROS mechanisms, indirect alterations in the levels of the antioxidant GSH relay signals lead to outputs such as changes in defense gene expression, as well. The *Arabidopsis rax1* mutant was identified due to its constitutive expression of APX2. It bears a mutation in the chloroplastic  $\gamma$ -glutamylcysteine synthetase, which results in lowered GSH levels (Ball et al. 2004). In non-stressed *rax1* plants, several defense genes have increased expression levels. This indicates that in wild type plants, level of GSH or the ratio of GSH to GSSH, known as the cellular redox balance, acts as a signal modulating the expression of defense genes.

Perception of ROS could also be mediated via the interaction of signaling components with elements in ROS detoxification. The nucleoside diphosphate kinase 1 from *Arabidopsis thaliana*, NDK1, interacts with three catalases (Fukamatsu et al. 2003) and its over-expression increases plant tolerance to paraquat and also to exogenous  $H_2O_2$ .

TRXs are important ROS detoxification mechanisms which can also be involved in ROS sensing. Several TRX isoforms are present in the chloroplast and the cytosol. They can reduce disulphide bonds in proteins and act as a hydrogen donor to reduce peroxiredoxin, which in turn reduces  $H_2O_2$ , lipid peroxides and peroxynitrite (Rouhier and Jacquot 2002). Thioredoxins interact with numerous proteins (Marchand et al. 2006). The modification of enzymatic activities of target proteins suggests novel ROS-sensing functions for the TRX-system beyond mere detoxification. Animal  $Ca^{2+}$  channels of the  $IP_3R$  type 1 are regulated via interaction with a TRX-type protein ERp44. The interaction is dependent on pH,  $Ca^{2+}$  and redox status (Higo et al. 2005). Intriguingly, one of the earliest events upon perception of extracellular ROS in plants is a distinct calcium response (Evans et al. 2005). This  $Ca^{2+}$  fingerprint is specific for different ROS. However, the identities and the regulation of the  $Ca^{2+}$ -channels involved remain unknown.

Both enzymatic and non-enzymatic lipid peroxidation have been previously implicated in ROS perception. Oxylipins resulting from enzymatic oxidation via lipoxygenases (LOX) might function in leaf senescence (Berger et al. 2001).



Oxylipins accumulate during the hypersensitive response after infection with avirulent strains of *Pseudomonas syringae*, while the accumulation in response to disease-causing strains is far less pronounced (Vollenweider et al. 2000). The delivery of typical lipid oxidation molecules induces the expression of GST1 but also causes severe damage of plant cells. This indicates that these resulting oxylipins are not simply toxic substances but are more likely to have additional functions in signaling.

### B ROS Downstream Signaling Networks

MAPKs (Fig. 2b) are well characterized in many cellular responses including disease, abiotic stress and development. Silencing of *Arabidopsis* MPK6 makes plants more susceptible to pathogen infection. Both pathogen infection and O<sub>3</sub> exposure induce the formation of ROS in the apoplastic space. MAPKs are also activated early during the response to O<sub>3</sub> in tobacco and *Arabidopsis* (Samuel et al. 2000; Ahlfors et al. 2004). Evidence from transient over-expression in protoplasts suggests that MAPK kinase kinases (MAPKKKs) can channel oxidative stress for MAP kinase activation in alfalfa (Nakagami et al. 2006). Upon activation by H<sub>2</sub>O<sub>2</sub> the *Medicago sativa* MAPKKK OMTK1 interacts with, and activates the *Medicago* MAPK 3 (MMK3) functioning in the activation of H<sub>2</sub>O<sub>2</sub>-induced cell death. In *Arabidopsis*, the H<sub>2</sub>O<sub>2</sub>-activated kinase oxidative-inducible 1 (OX-I1) is required for the full activation of MPK3 and MPK6 (Rentel et al. 2004). This pathway affects two very different ROS-influenced processes, the resistance to *Peronospora parasitica* and root hair growth.

MAPKs are regulated by protein phosphatases. Phosphatases can be targets of modification by ROS (as exemplified earlier with ABI2). Therefore it is not surprising that alterations in protein phosphatase activity affect ROS-associated MAPK signaling. Silencing of the *Arabidopsis thaliana* dual-specificity MAPK phosphatase MKP2 renders plants hypersensitive to oxidative stress through prolonged activation of AtMPK3 and 6 (Lee and Ellis 2007).

The MAPK module function is not only downstream of ROS. The *Arabidopsis thaliana* MAPKKK and MEKK1 is essential in the regulation

of ROS homeostasis (Nakagami et al. 2006). MPK4 is a likely downstream target of MEKK1. Both integrate ROS homeostasis with hormone signaling and development. A recent report shows DNA binding and the direct interaction of MEKK1 with a transcription factor WRKY53 (Miao et al. 2007), which is involved in the regulation of genes encoding proteins of antioxidative function (Miao et al. 2004). This shortcut could potentially change the view on MAPK signaling.

## IV Insights from Genetic and Genomic Strategies

### A Genomics and Microarrays

The site and type of ROS produced have a critical influence on which changes and the selectivity in gene expression can be detected (Gadjev et al. 2006). During the last few years, several full genome array experiments have been performed using ROS-treatments or plants with altered levels of ROS scavenging enzymes (e.g., O<sub>3</sub>, MV, anti-sense CAT and cytosolic ascorbate peroxidase-knock out plants), and other stresses (Gadjev et al. 2006). From these experiments, it can be shown that ROS induce both a common set of genes independent of the nature of ROS and, in addition, each ROS induces its own set of genes (Gadjev et al. 2006). Furthermore, different treatments leading to the same reactive species in the same location, for example, increased H<sub>2</sub>O<sub>2</sub> in the peroxisome, give similar expression patterns (Gadjev et al. 2006).

Two large scale analyses have recently been performed on ROS and abiotic stress-related full genome array data. One (Kilian et al. 2007) focused mainly on drought, cold and UV-B irradiation stress, while the other (Ma and Bohnert 2007) analyzed more than 30 treatments including abiotic-, oxidative-, biotic- stresses along with hormone and chemical treatments. Both identified a set of genes that might encompass the plant “universal stress response transcriptome” with important functions in various stress responses, analogous to yeast and mammals. The study by Kilian et al. (2007) focused on a very early time-point (30 min after treatment) which explains why their list of up-regulated genes is small ( nine vs. 197 genes in Ma and Bohnert 2007); however four

of these nine genes were common with both datasets. The majority of the genes identified in both datasets are also activated by ROS, which points to a role for ROS as an important initial signal for both early abiotic stress defenses and, in general, as an inducer of universal stress responses. However, ROS are not only a general inducer of stress responses, there is also specificity involved in ROS regulation of abiotic stress, for example, different ROS are generated in cells during various abiotic stresses (Gadjev et al. 2006).

In contrast to the wealth of data on gene expression, comparably little is known about transcription factors or the promoter elements they bind which regulate ROS induced genes. ROS responsive promoter elements can be divided into two classes, that is, elements experimentally verified by methods such as gel shift assays or promoter-reporter gene deletions, and elements enriched in promoters of ROS regulated genes, usually identified through full genome array analysis.

There are few experimentally verified ROS promoter elements: the *Arabidopsis* NRXe2 element (TGACGTCA) which responds to H<sub>2</sub>O<sub>2</sub> (Geisler et al. 2006); the rice co-ordinate regulatory element for antioxidant defense (CORE) which is activated by MV treatment (Tsukamoto et al. 2005); the tobacco activation sequence-1 (as-1)-like element activated by MV treatment (Apel and Hirt 2004); the antioxidant-responsive element in maize [ARE; TGACTCA; (Scandalios 2005)]; and an O<sub>3</sub>-responsive region of grapevine stilbene synthase (Schubert et al. 1997). Dissection of the *HSP70A* promoter in *Chlamydomonas reinhardtii* indicated that <sup>1</sup>O<sub>2</sub> and H<sub>2</sub>O<sub>2</sub> use distinct cis-elements (Shao et al. 2007).

In contrast to these verified promoter elements, many array studies have identified elements enriched in promoters of genes induced by ROS treatments and are likely candidates for regulation of ROS induced genes. This computational approach to find elements involves statistical analyses of promoters from co-regulated genes identified through full genome array analysis using one or more ROS treatments. The analysis can be limited to search for known elements or use a prediction algorithm to find novel elements (Geisler et al. 2006; Tosti et al. 2006). Using this approach, more than 15 promoter elements were significantly enriched in promoters of O<sub>3</sub>-induced genes, for example, the ABRE, ERF and

LS-7-motifs as well as the W-box (Mahalingam et al. 2005; Tosti et al. 2006). Several of these were also regulated by hormones, which supports the role of SA, ABA, and ET in plant ROS responses (Overmyer et al. 2003). One potential problem with this *in silico* approach is the question of their biological significance. However, the availability of improved algorithms with increased accuracy has allowed for selection of elements directly for experimental confirmation (Geisler et al. 2006).

As with promoter elements, there is a lack of experimental verification for transcription factors that regulate ROS induced genes. The expression of more than 500 transcription factors in *Arabidopsis* is altered by ROS treatment (Gadjev et al. 2006) indicating a large impact of ROS on transcriptional regulation. However, only a few transcription factors have an experimentally verified role in ROS-related gene expression regulation. Two *Arabidopsis* transcription factors, C<sub>2</sub>H<sub>2</sub>-EAR zinc finger proteins Zat10 and Zat12, were identified by over-expression *in planta*. These over-expressors displayed constitutively high levels of transcripts for ROS antioxidant enzymes and other defense genes (Davletova et al. 2005b; Mittler et al. 2006). The mutant phenotypes of *Arabidopsis ocp3* include constitutive high H<sub>2</sub>O<sub>2</sub> and expression of H<sub>2</sub>O<sub>2</sub> regulated genes suggesting that OCP3, a homeodomain protein, could be a negative regulator of H<sub>2</sub>O<sub>2</sub> signaling (Coego et al. 2005).

However, direct promoter binding has been shown for only one ROS related transcription factor. The H<sub>2</sub>O<sub>2</sub> inducible *Arabidopsis* WRKY53 binds to the CAT 1, 2 and 3 promoters and promoters of other transcription factors and signaling proteins (Miao et al. 2004). Using genomics tools, such as chromatin immuno-precipitation-DNA microarray, (ChIP-Chip) would be a way to identify and verify both the promoter elements and transcription factors involved in ROS signaling.

## B Transgenic Approaches

Transcriptional analysis of plants deficient in individual antioxidant enzymes has revealed distinct stress responses to accumulation of <sup>1</sup>O<sub>2</sub><sup>-</sup> and H<sub>2</sub>O<sub>2</sub> in chloroplasts and peroxisomes. Tobacco and *Arabidopsis* plants deficient in the peroxisomal CAT 2, which are unable to detoxify

photorespiratory  $\text{H}_2\text{O}_2$ , show distinct sensitivity and cell death upon illumination under high light intensity (Willekens et al. 1997; Vandenabeele et al. 2004). Microarray analysis of *Arabidopsis* CAT2 silenced plants revealed distinct rearrangements in the global pattern of gene expression, demonstrating a central role for peroxisomal  $\text{H}_2\text{O}_2$  in cellular stress signaling (Vandenabeele et al. 2004). Intriguingly, high-light-illuminated plants with 20% residual CAT activity (denoted as CAT2HP1) exhibited distinct down-regulation of a cluster of genes involved in anthocyanin biosynthesis (Vanderauwera et al. 2005). The opposite effect was observed in knock-down Cu/Zn SOD plants, which showed up-regulation of genes related to anthocyanin biosynthesis already under quite optimal growth conditions (Rizhsky et al. 2003). Thus, anthocyanin biosynthesis transcripts are transcriptionally up-regulated in response to  $\cdot\text{O}_2^-$ , while  $\text{H}_2\text{O}_2$  negatively interferes in the expression of these transcripts (Gadjev et al. 2006). This indicates cross-talk and specificity in signaling between different ROS.

### C $^1\text{O}_2$ Signal Transduction

The conditional *flu* mutant can generate  $^1\text{O}_2$  in a controlled and non-invasive manner providing an excellent tool to explore  $^1\text{O}_2$  signaling. The *flu* mutant accumulates a chlorophyll biosynthesis intermediate in the dark, which results in the release of  $^1\text{O}_2$  upon re-illumination. The accumulation of  $^1\text{O}_2$  leads to rapid and selective transcriptional reprogramming, and finally induces PCD in *flu* plants (op den Camp et al. 2003). Notably, the light-dependent release of  $^1\text{O}_2$  alone is not sufficient to induce the PCD response in *flu* seedlings: the *EXECUTER1* gene was found to be required for cell death in re-illuminated *flu* plants (Wagner et al. 2004). Further characterization revealed that activity of the cytoplasmic blue light receptor cryptochrome CRY1 and blue light is also required to trigger cell death. Expression profiling in the *flu* single and *flu cry1* double mutant indicated a subset of  $^1\text{O}_2$ -induced genes which required CRY1 to be activated (Danon et al. 2006). Thus, blue light has the ability to influence  $^1\text{O}_2$  signaling.

The vast majority of genes activated by  $^1\text{O}_2$  in *flu* were different from those induced by treating plants with MV, a herbicide that induces

generation of  $\cdot\text{O}_2^-$  in chloroplasts (op den Camp et al., 2003). Nevertheless,  $\text{H}_2\text{O}_2$  signaling seems to interact with signals that originate from  $^1\text{O}_2$  in chloroplasts. Over-expression of thylakoid APX (tAPX), a scavenger for  $\text{H}_2\text{O}_2$  in *flu* background led to enhanced  $^1\text{O}_2$ -dependent cell death as compared to the parental *flu* plants (Laloi et al. 2007). Moreover, the expression of  $^1\text{O}_2$ -induced genes was enhanced in the *flu tapx-ox* plants. Altogether, these findings lead to a conclusion that  $^1\text{O}_2$  signaling is fine-tuned by antagonistic effects of  $\text{H}_2\text{O}_2$  in chloroplasts.

## V Conclusions

The controlled production and action of ROS is critical to act as an “alarm” signal in the recognition and response to stress. Multiple intracellular sites of ROS formation differ in their capacity for production and chemical identity of ROS. The involvement of ROS in several developmental and inducible processes imply that there must be coordinated function of signaling network(s) that govern ROS-responses and subsequent processes, although detailed descriptions of the mechanisms of such interactions are lacking. The perception of ROS is still almost completely unknown. The subsequent signaling affects several downstream processes, which in turn lead to the induction of stress responsive genes. This ubiquity explains why the role of ROS as second messenger has raised considerable interest in diverse models and processes. Understanding the integration of ROS signaling can provide powerful tools for improving plant growth, productivity and product quality. The future challenge of this central area of plant biology is to elucidate pathway cross-talk and to understand the interaction mechanisms in the whole signal network.

## Acknowledgements

The funding sources acknowledged for this work are: Finnish Academy Centre of Excellence program (2006–2011) and research grant to JK (decision # 121576), Post-doctoral grants to KO (decision # 115034) and MB (decision # 108760). MW is supported by a Helsinki University Post-doctoral grant.

## References

- Agrawal GK, Iwahashi I, Rakwal R (2003) Small GTPase 'Rop': molecular switch for plant defense responses. *FEBS Lett* 546:173–180
- Ahlfors R, Macioszek V, Rudd J, Brosché M, Schlichting R, Scheel D, Kangasjärvi J (2004) Stress hormone-independent activation and nuclear translocation of mitogen-activated protein kinases in *Arabidopsis thaliana* during ozone exposure. *Plant J* 40:512–522
- Apel K, Hirt H (2004) Reactive oxygen species: metabolism, oxidative stress and signal transduction. *Annu Rev Plant Biol* 55:373–399
- Aro EM, Suorsa M, Rokka A, Allahverdiyeva Y, Paakkari V, Saleem A, Battchikova N, Rintamäki E (2005) Dynamics of photosystem II: a proteomic approach to thylakoid protein complexes. *J Exp Bot* 56:347–356
- Asada K (1999) The water-water cycle in chloroplasts: scavenging of active oxygen's and dissipation of excess photons. *Annu Rev Plant Physiol Mol Biol* 50:601–639
- Ball L, Accotto GP, Bechtold U, Creissen G, Funck D, Jimenez A, Kular B, Leyland N, Mejia-Carranza J, Reynolds H, Karpinski S, Mullineaux PM (2004) Evidence for a direct link between glutathione biosynthesis and defense gene expression in *Arabidopsis*. *Plant Cell* 16:2448–2462
- Bartoli CG, Gomez F, Martinez DE, Guaiamet JJ (2004) Mitochondria are the main target for oxidative damage in leaves of wheat (*Triticum aestivum* L.). *J Exp Bot* 55:1663–1669
- Baxter-Burrell A, Yang ZB, Springer PS, Bailey-Serres J (2002) RopGAP4-dependent Rop GTPase rheostat control of *Arabidopsis* oxygen deprivation tolerance. *Science* 296:2026–2028
- Berger S, Weichert H, Porzel A, Wasternack C, Kuhn H, Feussner I (2001) Enzymatic and non-enzymatic lipid peroxidation in leaf development. *Biochim Biophys Acta* 1533:266–276
- Bienert GP, Møller ALB, Kristiansen KA, Schulz A, Møller IM, Schjoerring JK, Jahn TP (2007) Specific aquaporins facilitate the diffusion of hydrogen peroxide across membranes. *J Biol Chem* 282:1183–1192
- Buchanan BB, Balmer Y (2005) Redox regulation: a broadening horizon. *Annu Rev Plant Biol* 56:187–220
- Coego A, Ramirez V, Gil MJ, Flors V, Mauch-Mani B, Vera P (2005) An *Arabidopsis* homeodomain transcription factor, over-expressor of cationic peroxidase-3, mediates resistance to infection by necrotrophic pathogens. *Plant Cell* 17:2123–2137
- Corpas FJ, Barroso JB, Del Rio LA (2001) Peroxisomes as a source of reactive oxygen species and nitric oxide signal molecules in plant cells. *Trends Plant Sci* 6:145–150
- Danon A, Coll NS, Apel K (2006) Cryptochrome-1-dependent execution of programmed cell death induced by singlet oxygen in *Arabidopsis*. *Proc Natl Acad Sci USA* 103:17036–17041
- Davletova S, Rizhsky L, Liang HJ, Zhong SQ, Oliver DJ, Coutu J, Shulaev V, Schlauch K, Mittler R (2005a) Cytosolic ascorbate peroxidase-1 is a central component of the reactive oxygen gene network of *Arabidopsis*. *Plant Cell* 17:268–281
- Davletova S, Schlauch K, Coutu J, Mittler R (2005b) The zinc-finger protein Zat12 plays a central role in reactive oxygen and abiotic stress signaling in *Arabidopsis thaliana*. *Plant Physiol* 139:847–856
- Despres C, Chubak C, Rochon A, Clark R, Bethune T, Desveaux D, Fobert PR (2003) The *Arabidopsis* NPR1 disease resistance protein is a novel cofactor that confers redox regulation of DNA binding activity to the basic domain/leucine zipper transcription factor TGA1. *Plant Cell* 15:2181–2191
- Dietz KJ, Jacob S, Oelze ML, Laxa M, Tognetti V, de Miranda SM, Baier M, Finkemeier I (2006) The function of peroxiredoxins in plant organelle redox metabolism. *J Exp Bot* 57:1697–1709
- Evans NH, McAinsh MR, Hetherington AM, Knight MR (2005) ROS perception in *Arabidopsis thaliana*: the ozone-induced calcium response. *Plant J* 41:615–626
- Feng W, Liu G, Allen PD, Pessah IN (2000) Transmembrane redox sensor of ryanodine receptor complex. *J Biol Chem* 275:35902–35907
- Foyer CH, Noctor G (2005) Redox homeostasis and antioxidant signaling: a metabolic interface between stress perception and physiological responses. *Plant Cell* 17:1866–1875
- Foyer CH, Lopez-Delgado H, Dat JF, Scott IM (1997) Hydrogen peroxide- and glutathione-associated mechanisms of acclimatory stress tolerance and signaling. *Physiol Plant* 100:241–254
- Fukamatsu Y, Yabe N, Hasunuma K (2003) *Arabidopsis* NDK1 is a component of ROS signaling by interacting with three catalases. *Plant Cell Physiol* 44:982–989
- Gadjev I, Vanderauwera S, Gechev TS, Laloi C, Minkov IN, Shulaev V, Apel K, Inzé D, Mittler R, Van Breusegem F (2006) Transcriptomic footprints disclose specificity of reactive oxygen species signaling in *Arabidopsis*. *Plant Physiol* 141:436–445
- Geisler M, Kleczkowski LA, Karpinski S (2006) A universal algorithm for genome-wide *in silico* identification of biologically significant gene promoter putative cis-regulatory-elements; identification of new elements for reactive oxygen species and sucrose signaling in *Arabidopsis*. *Plant J* 45:384–398
- Harndahl U, Hall RB, Osteryoung KW, Vierling E, Bornman JF, Sundby C (1999) The chloroplast small heat shock protein undergoes oxidation-dependent conformational changes and may protect plants from oxidative stress. *Cell Stress Chaperones* 4:129–138
- Hideg É, Barta C, Kalai T, Vass I, Hideg K, Asada K (2002) Detection of singlet oxygen and superoxide with fluorescent sensors in leaves under stress by photo-inhibition or UV radiation. *Plant Cell Physiol* 43:1154–1164
- Higo TW, Hattori MG, Nakamura TPD, Natsume T, Michikawa T, Mikoshiba KIN (2005) Subtype-specific



- and ER lumenal environment-dependent regulation of inositol 1,4,5-trisphosphate receptor type 1 by ERp44complex. *Cell* 120:85–98
- Iqbal A, Yabuta Y, Takeda T, Nakano Y, Shigeoka S (2006) Hydroperoxide reduction by thioredoxin-specific glutathione peroxidase isoenzymes of *Arabidopsis thaliana*. *FEBS J* 273:5589–5597
- Joo JH, Wang SY, Chen JG, Jones AM, Fedoroff NV (2005) Different signaling and cell death roles of heterotrimeric G protein alpha and beta subunits in the *Arabidopsis* oxidative stress response to ozone. *Plant Cell* 17:957–970
- Kanwischer M, Porfiriova S, Bergmuller E, Dormann P (2005) Alterations in tocopherol cyclase activity in transgenic and mutant plants of *Arabidopsis* affect tocopherol content, tocopherol composition and oxidative stress. *Plant Physiol* 137:713–723
- Kariola T, Brader G, Li J, Palva ET (2005) Chlorophyllase 1, a damage control enzyme, affects the balance between defense pathways in plants. *Plant Cell* 17:282–294
- Kilian J, Whitehead D, Horak J, Wanke D, Weigl S, Batistic O, Angelo C, Bornberg-Bauer E, Kudla J, Harter K (2007) The AtGenExpress global stress expression data set: protocols, evaluation and model data analysis of UV-B light, drought and cold stress responses. *Plant J* 50:347–363
- Kwak JM, Mori IC, Pei ZM, Leonhardt N, Torres MA, Dangl JL, Bloom RE, Bodde S, Jones JDG, Schroeder JI (2003) NADPH oxidase AtrbohD and AtrbohF genes function in ROS-dependent ABA signaling in *Arabidopsis*. *EMBO J* 22:2623–2633
- Laloi C, Stachowiak M, Pers-Kameczyc E, Warzych E, Murgia I, Apel K (2007) Cross-talk between singlet oxygen- and hydrogen peroxide-dependent signaling of stress responses in *Arabidopsis thaliana*. *Proc Natl Acad Sci USA* 104:672–677
- Larkindale J, Hall JD, Knight MR, Vierling E (2005) Heat stress phenotypes of *Arabidopsis* mutants implicate multiple signaling pathways in the acquisition of thermo-tolerance. *Plant Physiol* 138:882–897
- Lee JS, Ellis BE (2007) *Arabidopsis* MAPK phosphatase MKP2 positively regulates oxidative stress tolerance and inactivates the MPK3 and MPK6 mitogen-activated protein kinases. *J Biol Chem* 282:25020–25029
- Ma S, Bohnert HJ (2007) Integration of *Arabidopsis thaliana* stress-related transcript profiles, promoter structures and cell-specific expression. *Genome Biol* 8:R49
- Mahalingam R, Shah N, Scrymgeour A, Fedoroff N (2005) Temporal evolution of the *Arabidopsis* oxidative stress response. *Plant Mol Biol* 57:709–730
- Marchand C, Le MP, Meyer Y, Decottignies P (2006) Comparative proteomic approaches for the isolation of proteins interacting with thioredoxin. *Proteomics* 6:6528–6537
- Martinsuo P, Pursiheimo S, Aro EM, Rintamäki E (2003) Dithiol oxidant and disulfide reductant dynamically regulate the phosphorylation of light-harvesting complex II proteins in thylakoid membranes. *Plant Physiol* 133:37–46
- Mason JT, Kim SK, Knaff DB, Wood MJ (2006) Thermodynamic basis for redox regulation of the Yap1 signal transduction pathway. *Biochemistry* 45:13409–13417
- Maxwell DP, Wang Y, McIntosh L (1999) The alternative oxidase lowers mitochondrial reactive oxygen production in plant cells. *Proc Natl Acad Sci USA* 96:8271–8276
- Meinhard M, Rodriguez PL, Grill E (2002) The sensitivity of ABI2 to hydrogen peroxide links the abscisic acid-response regulator to redox signaling. *Planta* 214:775–782
- Miao Y, Laun T, Zimmermann P, Zentgraf U (2004) Targets of the WRKY53 transcription factor and its role during leaf senescence in *Arabidopsis*. *Plant Mol Biol* 55:853–867
- Miao Y, Laun TM, Smykowski A, Zentgraf U (2007) *Arabidopsis* MEKK1 can take a short cut: it can directly interact with senescence-related WRKY53 transcription factor on the protein level and can bind to its promoter. *Plant Mol Biol* 65:63–76
- Miller G, Mittler R (2006) Could heat shock transcription factors function as hydrogen peroxide sensors in plants? *Ann Bot* 98:279–288
- Mittler R, Vanderauwera S, Gollery M, Van Breusegem F (2004) Reactive oxygen gene network of plants. *Trends Plant Sci* 9:490–498
- Mittler R, Kim Y, Song LH, Couto J, Couto A, Ciftci-Yilmaz S, Lee H, Stevenson B, Zhu JK (2006) Gain- and loss-of-function mutations in Zat10 enhance the tolerance of plants to abiotic stress. *FEBS Lett* 580:6537–6542
- Møller IM, Jensen PE, Hansson A (2007) Oxidative modifications to cellular components in plants. *Annu Rev Plant Biol* 58:459–481
- Nakagami H, Soukupova H, Schikora A, Zarsky V, Hirt H (2006) A mitogen-activated protein kinase kinase kinase mediates reactive oxygen species homeostasis in *Arabidopsis*. *J Biol Chem* 281:38697–38704
- Noctor G, De PR, Foyer CH (2007) Mitochondrial redox biology and homeostasis in plants. *Trends Plant Sci* 12:125–134
- op den Camp RG, Przybyla D, Ochsenein C, Laloi C, Kim C, Danon A, Wagner D, Hideg E, Gobel C, Feussner I, Nater M, Apel K (2003) Rapid induction of distinct stress responses after the release of singlet oxygen in *Arabidopsis*. *Plant Cell* 15:2320–2332
- Overmyer K, Brosché M, Kangasjärvi J (2003) Reactive oxygen species and hormonal control of cell death. *Trends Plant Sci* 8:335–342
- Rao MV, Ormrod DP (1995) Impact of Uvb and O-3 on the oxygen-free radical scavenging system in *Arabidopsis thaliana* genotypes differing in flavonoid biosynthesis. *Photochem Photobiol* 62:719–726
- Rentel MC, Lecourieux D, Ouaked F, Usher SL, Petersen L, Okamoto H, Knight H, Peck SC, Grierson CS, Hirt H, Knight MR (2004) OXI1 kinase is necessary for oxidative burst-mediated signalling in *Arabidopsis*. *Nature* 427:858–861

- Rizhsky L, Liang H, Mittler R (2003) The water-water cycle is essential for chloroplast protection in the absence of stress. *J Biol Chem* 278:38921–38925
- Rouhier N, Jacquot JP (2002) Plant peroxiredoxins: alternative hydroperoxide scavenging enzymes. *Photosynth Res* 74:259–268
- Sagi M, Davydov O, Orazova S, Yesbergenova Z, Ophir R, Stratmann JW, Fluhr R (2004) Plant respiratory burst oxidase homologs impinge on wound responsiveness and development in *Lycopersicon esculentum*. *Plant Cell* 16:616–628
- Samuel MA, Miles GP, Ellis BE (2000) Ozone treatment rapidly activates MAP kinase signalling in plants. *Plant J* 22:367–376
- Scandalios JG (2005) Oxidative stress: molecular perception and transduction of signals triggering antioxidant gene defenses. *Braz J Med Biol Res* 38:995–1014
- Schubert R, Fischer R, Hain R, Schreier PH, Bahnweg G, Ernst D, Sandermann H (1997) An ozone-responsive region of the grapevine resveratrol synthase promoter differs from the basal pathogen-responsive sequence. *Plant Mol Biol* 34:417–426
- Shao N, Krieger-Liszkay A, Schroda M, Beck CF (2007) A reporter system for the individual detection of hydrogen peroxide and singlet oxygen: its use for the assay of reactive oxygen species produced *in vivo*. *Plant J* 50:475–487
- Sweetlove LJ, Lytovchenko A, Morgan M, Nunes-Nesi A, Taylor NL, Baxter CJ, Eickmeier I, Fernie AR (2006) Mitochondrial uncoupling protein is required for efficient photosynthesis. *Proc Natl Acad Sci USA* 103:19587–19592
- Torres MA, Dangl JL (2005) Functions of the respiratory burst oxidase in biotic interactions, abiotic stress and development. *Curr Opin Plant Biol* 8:397–403
- Tosti N, Pasqualini S, Borgogni A, Ederli L, Falistocco E, Crispi S, Paolucci F (2006) Gene expression profiles of O<sub>3</sub>-treated *Arabidopsis* plants. *Plant Cell Environ* 29:1686–1702
- Tsukamoto S, Morita S, Hirano E, Yokoi H, Masumura T, Tanaka K (2005) A novel cis-element that is responsive to oxidative stress regulates three antioxidant defense genes in rice. *Plant Physiol* 137:317–327
- Vandenabeele S, Vanderauwera S, Vuylsteke M, Rombauts S, Langebartels C, Seidlitz HK, Zabeau M, Van Montagu M, Inzé D, Van Breusegem F (2004) Catalase deficiency drastically affects gene expression induced by high light in *Arabidopsis thaliana*. *Plant J* 39:45–58
- Vanderauwera S, Zimmermann P, Rombauts S, Vandenabeele S, Langebartels C, Gruijsem W, Inzé D, Van Breusegem F (2005) Genome-wide analysis of hydrogen peroxide-regulated gene expression in *Arabidopsis* reveals a high light-induced transcriptional cluster involved in anthocyanin biosynthesis. *Plant Physiol* 139:806–821
- Vollenweider S, Weber H, Stolz S, Chetelat A, Farmer EE (2000) Fatty acid ketodienes and fatty acid ketotrienes: Michael addition acceptors that accumulate in wounded and diseased *Arabidopsis* leaves. *Plant J* 24:467–476
- Wagner D, Przybyla D, Op den Camp R, Kim C, Landgraf F, Lee KP, Wursch M, Laloi C, Nater M, Hideg É, Apel K (2004) The genetic basis of singlet oxygen-induced stress responses of *Arabidopsis thaliana*. *Science* 306:1183–1185
- Willekens H, Chamnongpol S, Davey M, Schraudner M, Langebartels C, Van Montagu M, Inze D, Van Camp W (1997) Catalase is a sink for H<sub>2</sub>O<sub>2</sub> and is indispensable for stress defense in C3 plants. *EMBO J* 16:4806–4816

## A Biotic or Abiotic Stress?

Alexandre Robert-Seilaniantz, Rajendra Bari, and Jonathan D. G. Jones(\*)  
*The Sainsbury Laboratory, Norwich Research Park, Colney Lane,  
 Norwich, NR4 7UH, UK*

Summary .....	103
I Introduction .....	104
II Biotic Stress Versus Abiotic Stress .....	105
III General Stress Response .....	105
IV ABA and Jasmonic Acid: Usual Suspects for Interaction .....	107
V New Points of Interaction .....	109
A Auxin, Cytokinin and Brassinosteroids: New Stress Hormones? .....	109
1 Auxin .....	109
2 Cytokinin and Brassinosteroids .....	111
B Salicylic Acid .....	112
C DELLA Proteins as Central Integrators? .....	113
VI Conclusions .....	116
Acknowledgements .....	117
References .....	117

### Summary

Throughout their lifespan plants are exposed to numerous biotic and abiotic stresses that may affect their normal growth, development and reproduction. In order to survive, they have evolved elaborate mechanisms to perceive and respond to each type of stress. A complex and still obscure network of interactions between hormones and genes expression allows the plant to fine tune the appropriate response. Each type of stress has received a great deal of attention and many important discoveries allow researchers to begin to unravel each signaling pathway. However, more and more evidence suggest that studying each response in isolation is an oversimplification. Indeed, plants are able to integrate multiple signals and respond to different stresses in a specific manner. Moreover, evidence indicates that each stress/pathway interacts with each other. Recent progress in transcriptome analysis and the construction of large databases centralizing microarray data from different laboratories, allows researchers to carry out comparative approaches. These types of approaches, revealed interesting and important networks. These give us the opportunity to understand the plant responses in a more comprehensive, integrative manner. In this chapter, we describe the role of different phyto-hormones in mediating various biotic and abiotic stress responses and also discuss the possible mechanisms by which they can provide tolerance to those stresses.

**Keywords** Brassinosteroid • cytokinin • DELLA protein • hypersensitive response • integrator • salicylic acid

---

\*Author for correspondence e-mail: Jonathan.Jones@sainsbury-laboratory.ac.uk

## I Introduction

Due to their sessile nature, plants need to adapt to changes in the environment. This plasticity in developmental response allows the plant to survive and cope with changing conditions and the different attacks it may encounter. Such changes in the growth conditions are often referred as stresses. They can be of two types: abiotic and biotic stresses. Abiotic stresses are caused by heat, cold or salt conditions whereas biotic stresses are caused by living organisms. Interestingly, upon any type of stress the plant slows its normal growth rate. Moreover, using genetic screens, researchers identified numerous mutants affected in stress responses and also showing abnormal growth phenotypes. These data indicate that growth and stress are regulated in a

concerted manner and therefore it is difficult to define one without the other. The plant therefore needs to integrate a multitude of positive and negative growth stimuli and induce the correct response. Much progress has been made recently to understand how plants respond to each type of stress and how it affects their development. At the same time, genome wide analysis such as microarrays, next generation sequencing and other large scale analysis, in combination with bioinformatics techniques, allow researchers to unravel more and more complex regulatory networks, to ask questions in a more integrative manner and give an opportunity to compare the plant response not to one stress but to a variety of different stresses. In doing so, we are in a position to begin to understand how the plant integrates responses to stresses (Fig. 1).

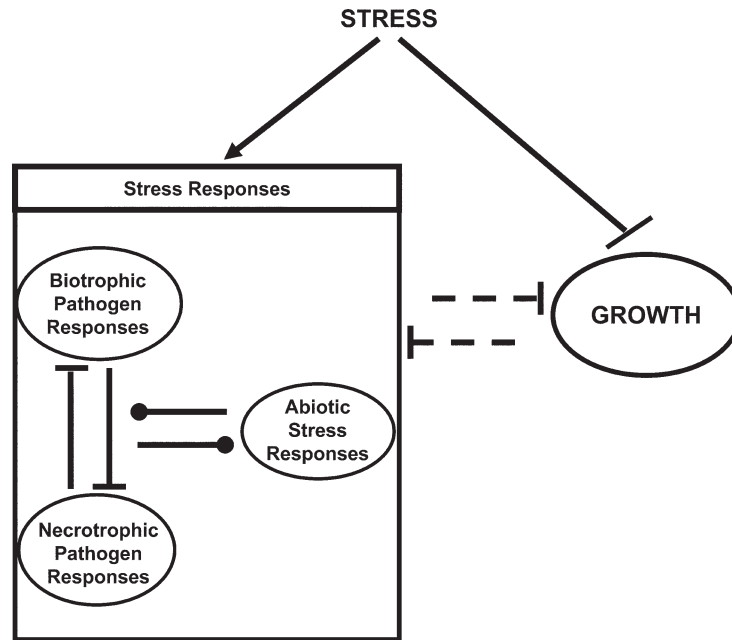

*Fig. 1.* Scheme indicating the general interaction between growth and stress. Stress responses and growth are antagonistic. Upon stress, the plant suppress/pauses (—|) the growth. So far, it is not clear where the pathways promoting growth and stress responses interact. The negative interaction between growth and stress (—|) could be at the stress response level or at the perception level. Similarly, it is not known if the growth promoting pathways have direct effect on the stress responses. The interaction between biotrophic and necrotrophic pathogens is clearly negative. Finally, the interaction between biotic and abiotic stress seem more complex than previously thought. Both positive and negative interaction (—●) have been reported. —>: induction; —|: repression; —|: hypothetical repression; —●: both positive and negative interaction have been reported.

*Abbreviations:* ABRE – abscisic acid responsive elements; AUX – auxin; BAP – 6-benzylaminopurine; BR – brassinosteroid; BXN – bromoxynil; CC-NBS-LRR – coiled-coil-nucleotide-binding site-leucine-rich repeats; ET – ethylene; ET-ACC – ethylene precursor aminocyclopropane-1-carboxylic acid; GA – gibberellic acid; GAI – gibberellic acid

insensitive; GID1gibberellin-insensitive dwarf1; GSH – glutathione; HR – hypersensitive response; IAA – indole-3-acetic acid; JA – jasmonic Acid; MeJA – methyl-jasmonate; PCD – programmed cell death; JAZ – proteins jasmonate ZIM-domain proteins; PRproteins pathogenesis-related proteins; ROS – reactive oxygen species; SA – salicylic acid



## II Biotic Stress Versus Abiotic Stress

Biotic stress is described as a stress produced by a living organism that can harm plants. These living organisms, also known as pathogens, are bacteria, virus, fungi and oomycetes. They can be broadly categorized in two classes depending on their life style: biotrophs and necrotrophs. Biotroph pathogens keep the plant cell alive and absorb nutrients from living tissues. To control these types of pathogens, the plant often induces a programmed cell death that kills the cell in the direct proximity of the microbe, limiting its spread. In contrast, necrotroph pathogens grow on dead tissues, often after inducing cell death. To respond to these two different types of invasion, plants have developed two distinct pathways. Resistance against biotroph pathogens is mediated by a salicylic acid (SA)-dependent pathway. Large genetic screens for either over-producers or mutants in this pathway demonstrated the role of this hormone in controlling the resistance to biotroph pathogens (Alvarez 2000; Kunkel and Brooks 2002; Halim et al. 2006; Robert-Seilaniantz et al. 2007). Interestingly, constant production of SA induces cell death and decreases the stature of the plant in many plants including *Arabidopsis*. Resistance to necrotroph pathogens is mediated by jasmonic acid (JA) and ethylene (ET)-dependent pathways. These two hormones have also a role in plant development. The interaction of JA and ET is not straight forward since both synergistic and antagonistic interactions have been reported (Kunkel and Brooks 2002; Robert-Seilaniantz et al. 2007). However, in the case of biotic stress, these two hormones have a synergistic interaction.

Abiotic stresses are caused by environmental factors such as drought, UV, elevated or depleted salt level. Although the stresses do not seem to be related between each other, the main pathway controlling the response to these stresses is controlled by one single hormone: abscisic acid (ABA). The level of this hormone increases during abiotic stress, especially during drought. Moreover, the change in ABA level is strongly correlated with metabolic change and gene expression. Both types of stresses impact the normal development of the plant. Interestingly, exogenous treatment of ABA results in an increased susceptibility to many pathogens (Koga et al. 2004; Mauch-Mani and Mauch 2005; Robert-Seilaniantz et al. 2007; de Torres-Zabala et al. 2007; Adie et al. 2007).

In a similar manner, application of an abiotic stress before a biotic stress makes the plant more susceptible to the pathogen (Koga and Mori 2004). Therefore, it is currently envisaged that the abiotic stress response is prioritized by the plant over the biotic stress response. However, recent studies demonstrated that the interaction between ABA and biotic stress response is more complex than just negative.

## III General Stress Response

The availability of large microarray datasets allows researchers to do comparative transcriptomics. Recently, Ma and Bohnert (2007, 2008) compared microarray data after different stress treatments. They included both biotic and abiotic stresses, as well as chemical stress. Interestingly, they found that a group of genes are induced in all type of stress. More specifically, it appears that 80% of those genes are regulated under each of the stress they tested. Therefore, they proposed that these genes represent a “universal stress response transcriptome”. Interestingly, it appears that the majority of these genes is conserved and is part of a stress response shared between plants and animals. Gene ontology analysis of this cluster revealed that responses to biotic or abiotic stress are over-represented. Nevertheless, this comparative approach demonstrated that plants respond to stress by regulating a general stress response and later on or at the same time induce a more specific answer to the problem they face. To this extent it would be interesting to understand how the plant reorganizes the transcription of stress-responsive genes towards a specific challenge. Moreover, it would be interesting to see if this general stress cluster is always turned on during the stress or if part of the specific response is to down-regulate the “unnecessary” part of the response. In a different study, Narusaka et al. (2004) investigated the role of Cytochrome P450 enzymes in different biotic and abiotic stresses. Cytochrome P450 are heme-containing enzyme involved in numerous biosynthetic reactions resulting in a wide range of lipophilic molecules, hormones and defense compounds for examples (Donaldson and Luster 1991). Despite their important role, little is known on their regulation during stresses. Narusaka et al. (2004) used a full length cDNA library containing 7,000 independent genes that included

49 cytochrome P450 genes. Their analysis revealed both specific and non-specific expression of P450 genes. Indeed they showed that some of the P450s are induced by both biotic and abiotic stresses. However, none of the genes is induced under every condition. These two studies are quite complementary since the types of stresses they chose are different. Ma and Bohnert (2007) use biotrophic pathogens as their biotic stress, whereas Narusaka et al. (2004) chose *Alternaria brassicicola* and *Alternaria alternata*, two necrotrophic pathogens. It is commonly accepted that necrotrophic pathogens induce abiotic stress during the interaction with the host. Nevertheless, the ability of the two studies to detect genes induced over a large number of stresses argue in favor of a set of genes involved in the general stress response. The two studies presented only one gene in common CYP707A3, a major enzyme for the regulation of ABA level in *Arabidopsis* under dehydration and rehydration. The expression of this gene showed a discrepancy between the two papers. Whereas, Ma and Bohnert (2007) included this gene in the “universal stress cluster” (N12), Narusaka et al. (2004) showed that this gene is induced only by ethylene, abscisic acid, drought, salt and water soaking. Glombitza et al. (2004) used a similar approach to identify secondary metabolism as a point of interaction between biotic and abiotic stress responses. In addition to CYP450, they included in their array glutathione-utilizing enzymes and ABC transporters. Secondary metabolites are induced upon biotic and abiotic stress and their roles have been discussed (Glombitza et al. 2004). The large variation of compounds produced by the plant allowed for a certain plasticity of the responses. Using principal component analysis, the authors clustered the gene responses according to their expression pattern after stress. Their analysis reveals two groups of genes differentially regulated upon every stress they applied. However, the comparison of the two groups revealed that one group is induced by all the stresses and repressed by methyl-jasmonate (MeJA) and ET, whereas the other group is repressed by UV-B and bromoxynil (BXN) treatment. These studies demonstrated that if secondary metabolism is part of the general stress response, the type of metabolite active during each stress may differ. One example is camalexin, which is synthesized through indole-3-acetaldoximide and

requires different CYP450 (Glawischnig 2006; Nafisi et al. 2007). This metabolite is the main phytoalexin in *Arabidopsis*. This molecule is part of the resistance reaction against many fungal pathogens (Nafisi et al. 2007; Ren et al. 2008), but has no effect against the biotroph pathogen *Pseudomonas syringae* pv. *tomato* DC3000 (Nafisi et al. 2007). In addition to its role in biotic stress response, camalexin is induced by abiotic stress such as oxidative stress and chemical stress (Zhao et al. 1998). Despite consensus approaches and despite the fact that most of the studies claim the isolation of a common stress response, the overlap seems rather limited. One possible explanation for the observed difference is the timing. Stress responses induce a large transcriptional reprogramming of the cell. As for any process, the observed response is partly dependent on the design of the experiment and the time of sampling. This could be in contrast with the previously named “general stress response”. However, the observed response is always a combination of both the general and the specific stress response. The mechanism by which the plant produces a specific response is still unclear. One possibility could be to suppress part of a general stress response and induce other genes/components of a stress pathway. Therefore, the timing would dictate, not the induction of the general stress response but the output of the response.

Another response shared between biotic and abiotic stress is reactive oxygen species (ROS). These are important molecules that can be a secondary messenger in many cellular processes, effector of plant defense or byproduct of aerobic metabolism. In every case, cells need to fight the highly toxic nature of these molecules. To control the damage induced by those versatile and important molecules, cells have a tightly controlled detoxifying systems that can balance the level of ROS. Microarray experiments revealed that induction of both production and detoxification is a common response after both biotic and abiotic stresses (Schenk et al. 2000; Kwak et al. 2003; Apel and Hirt 2004; Fujita et al. 2006; Torres et al. 2006; Achard et al. 2008). However, many differences exist in the production and regulation of these ROS. In biotic stress, the pathogen attack will trigger the production of ROS, mostly superoxide and hydrogen peroxide. This production occurs in the apoplast and is

dependent on two NADPH oxidases Atrboh D and AtrbohF (Torres et al. 2006). ROS are also tightly linked with SA. Both molecules are part of a positive feedback loop (Overmyer et al. 2003; Torres et al. 2006). Their role in defense against pathogens is similar and very important. The induction of ROS and the suppression of the detoxifying pathway potentiates the programmed cell death (PCD), making the plant more resistant to biotrophic pathogens. The role of ROS during this stress is not restricted to PCD and/or defense against biotrophs. ROS induces damages directly to the pathogen, reinforces the plant cell wall and plays the role of secondary messenger to prime the neighboring cells (Apel and Hirt 2004; Torres et al. 2006). Recently, Mateo et al. (2006) demonstrated another connection between SA and ROS. Using SA over-producer and mutants, the authors could correlate the level of SA with the level of glutathione (GSH) in leaves. High levels of SA are correlated with high levels of GSH. If GSH is part of the detoxifying mechanism, it is also a marker of oxidative stress. In line with these data, the authors could also observe an increase of ROS in plants with a high level of SA. This relationship between ROS, SA and GSH demonstrates that, more than the level of any single component, the ratio between the components is crucial for the plant response to stress. During abiotic stress, ROS can be the result of perturbation induced by the stress (Apel and Hirt 2004). During aerobic metabolism in leaves, oxygen is constantly produced and detoxified by tightly regulated mechanisms. Any perturbation of the balance between production and detoxification will result in production of ROS. For example, during high light stress, the cell is not able to produce sufficient acceptor for the electrons generated by the photosystems, resulting in an increase in ROS levels (Asada 1999; Bechtold et al. 2008). However, this production is not always a passive process. Active production of ROS by AtrbohD and AtrbohF is required for stomatal closure under drought condition (Kwak et al. 2003; Apel and Hirt 2004; Fujita et al. 2006). In both biotic and abiotic stress, ROS have a role in signal transduction. For example, Takahashi et al. (2004) demonstrated an important overlap between genes induced or repressed by ABA and ROS. In addition, ABA induces production of ROS (Yan et al. 2007). Similarly, correlation between SA and ROS

levels is indicative of a crosstalk (Mateo et al. 2006). More importantly, treatment of plants with SA induces production of ROS (Draper 1997). The reverse is also true since exposure of plants to ozone resulted in an increase of SA (Overmyer et al. 2003). Moreover, the regulation of NPR1, a key component in the SA pathway relies on the redox status of the cell (Mou et al. 2003). The place of ROS in a pathway is therefore difficult to estimate. The consequence of ROS production is different depending on the type of stress. In abiotic stress, production of ROS damages plant cells and its removal is essential for the survival of the plant. However, during biotic stress, ROS not only damages the plant cells but also damages the pathogen and reinforces the passive defense such as the cell wall. Therefore, it is not surprising to see an antagonistic effect of the modification of the ROS production/detoxification on biotic and abiotic stress (Apel and Hirt 2004; Torres et al. 2006). One counter example of this antagonistic effect of ROS on biotic and abiotic stress comes from a more developmental role of these molecules. In the stomata, ROS production is an important inducer of stomatal closure. Closure of stomata is an important response during drought stress (Apel and Hirt 2004; Yan et al. 2007). At the same time stomata are believed to be the point of entry of bacterial pathogens like *Pseudomonas* spp. Melotto et al. (2006) demonstrated that pathogen recognition induced stomatal closure. This closure is dependent on production of ROS (NO). Moreover, the re-opening of this gate is actively induced by the pathogen.

#### IV ABA and Jasmonic Acid: Usual Suspects for Interaction

ABA is a well studied hormone that has roles in both development and stress responses. From a developmental point of view, ABA is required for seed dormancy, fruit abscission, stomatal closure and leaf senescence (Fedoroff 2002; Barrero et al. 2005, 2008). At the same time, ABA is essential for plant responses to abiotic stress such as drought, salt and cold (Verslues and Zhu 2005; Yamaguchi-Shinozaki and Shinozaki 2005; Agarwal et al. 2006; Kariola et al. 2006). Elevated levels of this hormone are required for the stress response. Therefore, mutation or over-expression of

components of the ABA pathway often results in an alteration of abiotic stress tolerance of the plant (Verslues and Zhu 2005; Yamaguchi-Shinozaki and Shinozaki 2005; Agarwal et al. 2006; Kariola et al. 2006). Recently, three different proteins have been proposed to be receptors of ABA (Razem et al. 2006; Shen et al. 2006, Hirayama and Shinozaki 2007; Liu et al. 2007), but the true ABA receptor is still controversial. The mechanism of induction of the signaling pathway is still not clear. ABA has also been involved in the response to biotic stress (Audenaert et al. 2002; Mohr and Cahill 2003, 2006; O'Donnell et al. 2003a, b; Schmelz et al. 2003; Anderson et al. 2004; Koga and Mori 2004; Mauch-Mani and Mauch 2005; Melotto et al. 2006; de Torres-Zabala et al. 2007; Robert-Seilaniantz et al. 2007). PstDC3000 enhances the production of ABA during disease (Truman et al. 2006) suggesting that ABA is a susceptibility factor for this bacterium. In addition, some effectors from this bacterium specifically target this pathway (de Torres-Zabala et al. 2007; Goel et al. 2008). This finding echoes older studies where application of ABA or abiotic stress treatment enhances the susceptibility of rice toward *Magnaporthe grisea* (Koga and Mori 2004) and where the level of ABA was correlated with the susceptibility toward PstDC3000 (Schmelz et al. 2003; O'Donnell et al. 2003a, b) and *Hyaloperonospora arabidopsidis* (Mohr and Cahill 2003). Therefore, ABA seems to act as a negative regulator of the SA pathway. Indeed, the ABA insensitive tomato mutant *sitiens* shows an increase in SA-mediated responses and shows higher resistance toward PstDC3000 and *B. cinerea* (Audenaert et al. 2002). It is important to note that in tomato, *B. cinerea* is controlled by SA-mediated resistance and not ethylene as in *Arabidopsis*. Conceivably, *B. cinerea* has a very short biotrophic phase during which it is susceptible to SA-mediated defense mechanisms. More recently, Mohr and Cahill (2006) demonstrated that ABA suppresses SA and lignin accumulation. Interestingly, ABA can also interfere with the JA/ET pathway. Mutations in *EIN2* confer ethylene insensitivity and show higher susceptibility against a necrotrophic pathogen. In addition to this ethylene phenotype, *ein2* mutants overproduce ABA (Wang et al. 2007b). Interestingly, *ein2* mutants are hypersensitive to both salt and osmotic stress. This increase in susceptibility is

ABA dependent (Wang et al. 2007b). Moreover, *ein2* mutants are resistant to ABA treatment (Beaudoin et al. 2000), indicating that ABA triggered-inhibition requires a functional *ein2* protein. Taken together, these data indicate that EIN2 is at a node between ABA and ethylene. Another example of the negative interaction between ABA and JA/ET signaling is revealed by mutation of *Atmyc2/JIN2*. This transcription factor was originally identified as regulating the ABA signaling pathway. Mutations in this gene also result in elevated induction of JA controlled defense genes such as PDF1.2, causing an elevated resistance toward necrotrophs, and an inhibition of JA controlled wound response genes. This study shows that ABA acts as a negative regulator of JA/ET controlled pathogen responses. Anderson et al. (2004) confirmed these data showing that exogenous application of ABA suppressed JA/ET induction of defense genes. Taken together, these data show that ABA can negatively regulate the plant defense pathway against both necrotrophic and biotrophic pathogens. It raises the possibility that ABA allows the plant to prioritize resistance toward abiotic stress over biotic stress.

JA has also a broad effect on plant physiology. This hormone has been involved in pollen development, root growth, tuberization, pathogen response, wound response, ozone response, and water deficit (Devoto and Turner 2003). Recently, our understanding of the JA signaling pathway has been greatly improved. Jasmonate-isoleucine is now believed to be the active signal and COI1 is the receptor of this signal (Melotto et al. 2008). This discovery explains the important role of JAR1 that conjugates isoleucine on jasmonic acid (Staswick et al. 2002), thus making it active. More importantly, JAZ proteins that negatively regulate JA signaling have been discovered. The mechanism of induction of the JA pathway by JA-isoleucine is similar to the AUX/IAA mechanism (Quint and Gray 2006; Parry and Estelle 2006). JA-isoleucine acts as molecular glue between JAZ protein and COI1. Interaction with COI1 targets the JAZ protein for degradation, allowing the induction of the pathway (Thines et al. 2007; Chini et al. 2007; Staswick 2008). The role of JA in abiotic stress response is largely based on its induction of the antioxidant pathway (Porta et al. 1999; Devoto



and Turner 2003; Sasaki-Sekimoto et al. 2005). A mutation of a JA biosynthetic gene (*opr3*) renders the plant more susceptible to ozone exposure because of the lack of antioxidant gene induction (Sasaki-Sekimoto et al. 2005). Similarly, water stress can increase ROS level in the cell. Therefore, the induction of antioxidants is a necessary response. However, water stress also induces membrane damage. JA also induces lipoxygenases. These enzymes could have a functional role in the response against membrane alteration (Porta et al. 1999). The role of JA in both wounding and pathogen responses are linked. Wounds are induced by wind and herbivores. Increase in JA levels result in induction of multiple toxic secondary metabolites and attraction of herbivore predators (Gols et al. 2003). JA has also a well studied role in plant responses against necrotrophic pathogens. The ability of this hormone to induce ROS detoxifying enzymes allows the plant to create ROS that damage the pathogen without affecting the plant cell. In addition, application of high levels of JA increases the transcription of a number of genes with antimicrobial activity such as PDF1.2 (Penninckx et al. 1996).

ABA and JA have a broad effect throughout plant development. During stress responses, the two signals can be antagonistic (review in Robert-Seilaniantz et al. 2007). One point of interaction is MYC2. In this case, the negative interaction allows the specialization of the JA response towards wound responses over pathogen responses (Anderson et al. 2004). Interestingly, MYC2 is also required for the suppression of SA pathway by JA (Laurie-Berry et al. 2006). This indicates a complex regulation of MYC2 since it has been involved in both negative and positive effects on the JA mediated pathogen response. Recently, Adie et al. (2007) demonstrated another interaction between these two hormones. Using a *Pythium irregulare* and *Arabidopsis* patho-system, they showed that ABA is an essential signal for JA biosynthesis. *P. irregulare* is a necrotrophic pathogen upon whose attack, the plant induces JA pathways. By analysis of the cis-elements of the genes induced during the interaction, they observed an enrichment of abscisic acid responsive elements (ABRE). To test this hypothesis, they challenged different ABA mutants and could show that lack of production or perception of ABA resulted in increased

susceptibility against this pathogen. Interestingly, this observation is not true for every necrotroph pathogen since they tested two other pathogens, *Alternaria brassicicola* and *Botrytis cinerea*. If *A. brassicicola* behaved in a similar manner as *P. irregulare*, ABA mutants were more resistant to *B. cinerea*. These data indicated that each pathogen has specificity in their ability to subdue the plant defenses. At the same time, these data are not surprising since ABA has already been reported to play a role in *B. cinerea* susceptibility (Audenaert et al. 2002). Moreover, *B. cinerea* is able to produce ABA by itself (Hirai et al. 2000; Inomata et al. 2004). Finally, they quantified JA and JA precursor (OPDA) in an ABA biosynthetic mutant (*aba2-12*) and discovered that after infection with *P. irregulare*, no increase of JA or its precursor could be observed in the mutant.

ABA and JA are attractive candidates for hormones that influence responses to biotic and abiotic stresses. Both hormones have important roles in response to the two types of stresses. It is widely accepted that necrotrophic pathogens induce damage which is related to abiotic stress. Nevertheless, recent studies demonstrated an active role, possibly in the fine tuning of the response, of these two hormones in general stress responses.

## V New Points of Interaction

### A Auxin, Cytokinin and Brassinosteroids: New Stress Hormones?

#### 1 Auxin

Recent work from our laboratory provided new insights into the involvement of auxin in plant pathogen interaction. Navarro et al. (2004, 2006) discovered that treatment of the plant with the surrogate PAMP flg22 triggered the induction of microRNA, miR393. Flg22 is a synthetic peptide derived from the flagellum of bacteria. This peptide is recognized by the plant through a direct interaction with a LRR-RLK (FLS2). The interaction of flg22 and FLS2 triggers a resistant reaction and limits the spread of the pathogen (Gomez-Gomez and Boller 2000; Gomez-Gomez et al. 2001; Zipfel et al. 2004). Interestingly, miR393 targets mRNAs for the auxin receptor TIR1 and

several of its paralogs, down-regulating the auxin signaling pathway. In this study, Navarro et al. (2006) demonstrated that inability of the plant to down-regulate the auxin pathway increases the plant susceptibility toward PSTDC3000. In contrast, over-expression of miR393 increased the plant resistance against the same pathogen. Using microarray analysis, Wang et al. (2007a) demonstrated that SA represses auxin signaling. The mechanism they inferred is that by suppressing TIR1 expression, SA stabilized the AUX/IAA proteins that act as negative regulators of the auxin pathway. Indeed, they could demonstrate that treatment of the plants with SA stabilized at least AXR2, one of the AUX/IAA proteins without affecting TIR1 protein stability. Consistent with these data, Llorente et al. (2008) challenged different auxin signaling mutants with *Botrytis cinerea* and *Plectosphaerella cucumerina*. In both cases, they observed an increase in susceptibility. The role of auxin in plant pathogen interactions is not limited to *Arabidopsis* or to dicots. Using the rice *Xanthomonas oryzae* pv. *oryzae* (Xoo) pathosystems, Ding et al. (2008) demonstrated that overexpression of GH3-8 rendered the plant more resistant to Xoo. GH3 proteins are adenylate-forming enzymes that conjugate amino acids to different molecules such as auxin in this case. In *Arabidopsis*, the addition of amino-acid to auxin inactivates the hormone. Therefore, this study showed that as in *Arabidopsis*, low auxin rendered the plant more resistant to a biotrophic bacterial pathogen. Interestingly, the authors suggested a different mechanism. In this case, the increased resistance observed is independent of SA or JA.

The role of the same hormone in abiotic stress tolerance is less understood, but some papers point out that auxin might have a role in abiotic stress responses too. The microRNA miR393 is also induced during abiotic stresses. In 2004, (Sunkar and Zhu 2004) isolated 43 microRNAs and investigated their expression pattern. MiR393 is induced by cold, dehydration, high NaCl and ABA. However, its role in abiotic stress response is still unclear. AtNAC2 is a transcription factor involved in salt stress response and lateral root development (He et al. 2005). This gene is highly induced after salt treatment, ABA, ET (ACC) and auxin. Interestingly, mutations in the ABA signaling pathway did not affect the salt induction of

AtNAC2. However, a mutation in TIR1, one of the auxin receptors, and in *ein2* and *etr1*, two components of the ethylene signaling pathway, reduced this induction. This result indicated that the salt response of AtNAC2 required a functional auxin and/or ethylene signaling pathway. Moreover, this result suggests a positive role of auxin in the induction of this gene in salt stress response. Unfortunately, over-expression or knock out of AtNAC2 does not seem to have any effect on the survival of the plant under high salt conditions. The only phenotype the authors reported was an increase in lateral root production when AtNAC2 is over-expressed, which is consistent with the increase of lateral roots during salt stress in WT plants. AtNAC2 is part of a plant specific gene family. The absence of phenotype observed in the mutant could be explained by redundancy. The role of auxin during abiotic stress is not always positive. Park et al. (2007) recently reported the isolation of WES1-D, a GH3 protein that can conjugate aspartate onto IAA and therefore inactivated the hormone. WES1-D is over-expressed in the mutant due to the presence of a T-DNA containing a 35S enhancer in the vicinity of the gene. The authors could show that in WES1-D plants, the SA pathway was constantly induced and the plant was more resistant to the virulent pathogen PST DC3000. This result echoed previous published results demonstrating that the auxin pathway is a negative regulator of plant defense against biotrophs. Importantly, they also showed that WES1-D is more resistant to many abiotic stresses such as cold, heat and drought.

If the role of auxin as a stress hormone in plants is becoming clearer, it is worth noting that auxin plays a role in stress response in microbes. Many bacteria are able to produce IAA through a tryptophan pathway (Brandl and Lindow 1996, 1998; Glickmann et al. 1998; Valls et al. 2006; Robert-Seilaniantz et al. 2007). The role and the reasons of this production are still poorly understood. However, many bacteria use IAA in pathogenic interactions (Mazzola and White 1994; Glickmann et al. 1998; Schmelz et al. 2003; O'Donnell et al. 2003a; Maor et al. 2004; Robert-Seilaniantz et al. 2007) and induce tumors or hairy roots (Palm et al. 1989; Robinette and Matthyse 1990; Robert-Seilaniantz et al. 2007). One possible explanation is given by Robinette and Matthyse (1990) where they demonstrated that the presence

of auxin production genes in the T-DNA was correlated with inhibition of the hypersensitive response (HR) induced by a non-host pathogen. Similarly, Park et al. (2007) demonstrated that addition of auxin down-regulated the SA signaling pathway. In addition to direct effects on the host physiology, auxin helps the bacteria to survive under stress conditions. On plant leaves, many epiphytic bacteria are able to produce auxin (Brandl and Lindow 1996, 1998; Brandl et al. 2001; Manulis et al. 1998). For *Erwinia herbicola* pv. *gypsophylae*, the production of auxin has been correlated with both disease severity and epiphytic fitness (Manulis et al. 1998). Interestingly, this bacterium has two different pathways for auxin production. Manulis et al. (1998) could demonstrate that one pathway is important for disease severity whereas the other is involved in epiphytic fitness of the bacteria on the leaf surface. Bianco et al. (2006a, b) demonstrated the effect of IAA on *Escherichia coli*. Using in vitro culture, they tested the survival rate of this bacterium after different abiotic stresses. After treatment with IAA, *E. coli* increased its survival rate under heat shock, cold shock, UV irradiation, osmotic shock, acid shock, and oxidative stress, treatment with antibiotics, detergents and dyes. Microarray experiments suggest that a third of the genes with altered expression after IAA treatment are related to cell envelope or adaptation to stress conditions. Furthermore, cells treated with IAA showed an increase in trehalose, lipopolysaccharides and exopolysaccharides.

Work from our laboratory as well as other laboratories demonstrates that auxin plays a negative role in plant defense against biotroph pathogens. At the same time, microbial studies demonstrated that auxin treatment of many microbes result in gene induction and increased stress tolerance. Consistent with this, Brandl et al. (2001) could demonstrate that in *Erwinia herbicola* the induction of the auxin pathway is dependent on the microenvironment at the direct proximity of the bacteria. In this bacterium, the auxin pathway is induced during epiphytic phase on the plant surface and under low water availability. Importantly, mutation of this pathway reduces the epiphytic fitness of *Erwinia herbicola* (Brandl and Lindow 1998). These data raised the hypothesis that the down-regulation of the auxin pathways during plant pathogen interaction could be an

attempt from the plant to decrease the survival rate of the pathogen under the stress condition of the apoplast. Unfortunately, to our knowledge no bacteria affected in the auxin biosynthetic pathway have been isolated so far in the numerous screens performed to isolate less virulent bacteria. One possible explanation is that in addition to producing auxin, many pathogens induce the production of auxin from its host (Schmelz et al. 2003; O'Donnell et al. 2003a; Robert-Seilaniantz et al. 2007).

## 2 Cytokinin and Brassinosteroids

As with auxin, the role of cytokinin in stress responses is not well studied. Nevertheless, some reports implicate this hormone during certain stress. Cytokinin can be produced by microbes (Lichter et al. 1995; Murphy et al. 1997; Walters and McRoberts 2006). Gall-forming bacteria like *Agrobacterium tumefaciens* and *Rhodococcus fascians* produce both auxin and cytokinin (Robinette and Matthysse 1990; Goethals et al. 2001). In addition, many biotrophic but not necrotrophic pathogenic fungi produce cytokinin (Lichter et al. 1995; Murphy et al. 1997; Walters and McRoberts 2006). These data suggest a negative role for cytokinin in resistance against biotroph pathogens. Consistent with this, cytokinin has been involved in suppression of HR in a similar manner to auxin (Robinette and Matthysse 1990). Cytokinin has also been involved in the production of "green islands" in cereals and retardation of senescence after rust fungi infection (Walters et al. 2006, 2008). More recently and surprisingly, Igari et al. (2008) isolated a gain of function mutant of *Arabidopsis* that showed high accumulation of cytokinin. This mutant called UNI-1D carried a mutation in a CC-NBS-LRR protein that rendered this protein constitutively active. In addition to the high accumulation of cytokinin, this mutant has high accumulation of SA and up-regulation of PR proteins. Because high SA makes the plant more resistant to biotroph pathogens, these data are quite unexpected. Therefore, the regulation of interaction between cytokinin and SA seems to be more complex and as for other hormones, positive and negative regulation may characterize their functions.

A common feature of different stresses is that they impair normal growth of the plant. Therefore, one could expect that developmental hormones decrease

during stress. Indeed, the level of cytokinin decreases during water stress as shown in tobacco W38 and in maize (Havlova et al. 2008; Alvarez et al. 2008). According to these two papers, the decrease in cytokinin level is mainly due to the activity of one enzyme: cytokinin oxidase. In maize, this enzyme is induced by cytokinin, ABA and abiotic stress (Alvarez et al. 2008) making a direct link between cytokinin down-regulation and abiotic stress tolerance. Importantly, the negative role of cytokinin on drought stress seems to be limited to the aerial part. In tobacco, Havlova et al. (2008) demonstrated that if a decrease in bioactive cytokinin is observed in leaves during drought stress, under severe drought stress conditions an increase of bioactive cytokinin could be observed in the roots. In addition to the tissue, the type of cytokinin can make a difference. Using maize xylem sap, Alvarez et al. (2008) measured the metabolic and proteomic change during drought stress. As previously described, they observed a decrease in both zeatin and zeatin riboside. However, they also showed that another cytokinin: 6-benzylaminopurine (BAP) increases over the same period. One possible explanation lies in the different effects reported for these two compounds. Zeatin is a positive regulator of stomatal opening. BAP does not have any reported effect on stomata (Pospisilova 2004). The role of BAP may be to delay senescence of the upper leaves. Moreover, high concentrations of BAP also induce proline accumulation which helps to maintain the osmotic pressure during water stress. Consistent with this result, the authors also found an increase in proline.

Brassinosteroids (BR) are naturally occurring steroid hormones with an essential role in plant growth. Their effect on stress tolerance has been observed (review in Krishna 2003) but few reports are available. BR treatment increases plant tolerance to abiotic stress such as high and low temperature, high salt level and drought stress. Kagale et al. (2007) demonstrated that pre-treatment of seedling with BR increased expression of some cold- and drought-responsive genes in *Arabidopsis* and *Brassica napus*. The effect of BR on heat stress is more complex. Dhaubhadel et al. (2002) found that in *Brassica napus*, treatment of the plant with BR increased the transcription of heat shock protein genes. However, Kagale et al. (2007) found that it is not the case in *Arabidopsis*.

The role of BR on biotic stress is also mostly unknown. Treatment of plant with this hormone results in an increased resistance towards a large

variety of biotrophic and hemibiotrophic pathogens (Nakashita et al. 2003; Krishna 2003; Robert-Seilaniantz et al. 2007). Interestingly, this effect seemed to be independent of SA (Nakashita et al. 2003).

The mechanism by which BR promotes stress tolerance is mostly unknown. Most of the reports currently available are based on exogenous application of BR. Jager et al. (2008) investigated the effect of water stress on endogenous BR in pea. They observed a large increase of ABA, as expected, but no significant change in the level of castasterone (an active BR) could be observed. Moreover, mutations in either the perception or biosynthesis of BR did not affect the plant's ability to respond to water stress. Observed effects of BR treatment on stress responses seem to indicate an indirect involvement. The ability of BR to interact with other hormones (Haubrick and Assmann 2006) may be the reason of this effect. More experiments are necessary in order to draw conclusions about the exact role and more importantly by which mechanism BR treatment and/or BR affect plant response to stress.

### B Salicylic Acid

The role of SA in plant pathogen interaction is well studied and many reviews are available (Kunkel and Brooks 2002). Its role in abiotic stress is less studied but not ignored (Metwally et al. 2003; Chini et al. 2004; Gunes et al. 2007; Chen et al. 2007; Seo et al. 2008; Catinot et al. 2008). Work in rice (Chen et al. 2007) and in barley (Metwally et al. 2003) demonstrated a positive role of SA on heavy metal tolerance. However, the mechanism by which SA increases metal tolerance in these two cereals seems to differ. In barley, Metwally et al. (2003) tested cadmium (Cd) stress. In rice, Chen et al. (2007) tested lead (Pb) stress. In both cases, pretreatment of seedlings with SA increased the tolerance of these plants against each metal stress. However, if Chen et al. (2007) could correlate this increased tolerance to the induction of H<sub>2</sub>O<sub>2</sub> detoxifying enzymes, Metwally et al. (2003) found that the SA pretreatment lowered the Cd-dependent increase of antioxidant enzymes. Production of SA is also part of the response to UV (Glombitza et al. 2004). Moreover, Catinot et al. (2008) demonstrated recently in tobacco that this production is dependent on isochorismate synthase as for biotic stress response.



### C *DELLA Proteins as Central Integrators?*

DELLAs are highly conserved protein members of the GRAS family (Harberd 2003). They are postulated to be negative regulators of growth. Therefore, a high level of DELLA protein is correlated with a small plant size whereas suppression of these proteins is correlated with a larger plant size. More specifically, DELLAs act as repressors of the gibberellic acid (GA) signaling pathway. In fact, they are the key regulators of GA signaling. The repressor activity of DELLA proteins is relieved upon GA treatment. GA is perceived by its receptor *GID1* (gibberellin insensitive dwarf 1). DELLA proteins interact with *GID1* in a GA dependent manner. The interaction of *GID1* and DELLA proteins triggers the ubiquitination of DELLAs and their degradation by the proteasome (Harberd 2003; Jiang and Fu 2007; Schwechheimer 2008). If the repressor activity of DELLA is known, the mechanism by which DELLA proteins repressed genes was unclear until recently. Two back to back papers, by De Lucas et al. (2008) and Feng et al. (2008), gave important insights into this mechanism. These two studies isolated DELLA interacting proteins and both teams isolated related proteins, two bHLH transcription factors involved in phytochrome-mediated light signaling: PIF3 and PIF4. De Lucas et al. (2008) found that PIF4 interact with DELLAs, and Feng et al. (2008) found that PIF3 interacts with DELLAs. Importantly, they found that these interactions are dependent on GA. In the absence of hormone, DELLA proteins are in the nucleus and interact with either PIF3 or PIF4. These interactions prevent the proteins from promoting the expression of their target genes. Once GA is present, DELLA proteins are degraded, releasing PIF3/PIF4 from their restraint. Then the phytochrome-mediated light signaling pathway can be induced. Interestingly, PIF4 is proposed to be a negative regulator of the phytochrome pathway (Huq and Quail 2002). The role of PIF3 seems to be more complex (Kim et al. 2003). Both positive and negative regulations have been observed depending on the quality of light. One possible explanation is that once relieved from the DELLA restraint, PIF3 or/and PIF4 induce negative regulator of the phytochrome pathway. At the same time, both transcription factors could

bind cis-acting elements, such as G-Box for PIF4, and repress or activate the expression of the targeted genes. It is worth noticing that the mechanism of de-repression of a hormonal pathway by degradation of a repressor seems conserved between different hormone pathways (Quint and Gray 2006; Katsir et al. 2008).

Growth and stress are often opposed. When the plant is undergoing biotic or abiotic stress, a retardation of development is observed. Similarly, deregulation of the stress responsive pathways often results in dwarfism (e.g., SA pathway). Because DELLA proteins are well studied negative regulators of growth, they are very attractive candidates for a putative integrator of growth and stress signals. Interestingly, a large amount of data demonstrated that these proteins lie at a node of many hormones. The role of GA on DELLA is probably the most important and the most direct. However, auxin, ethylene, cytokinin and ABA (Zentella et al. 2002, 2007; Achard et al. 2003, 2006, 2007b; Fu and Harberd 2003; Weiss and Ori 2007), at least have an effect on these proteins directly or indirectly by acting on GA signaling and/or biosynthesis.

Auxin directly affects the stability of DELLA proteins. Fu and Harberd (2003) demonstrated that auxin is required for the promotion of root elongation by GA. Using genetic and molecular biology tools, they clearly showed that auxin transport is important for the destabilization of DELLA proteins by GA in roots. In addition, they could demonstrate that the negative regulator of auxin signaling pathways, *AUX/IAA* proteins, promoted the stabilization of DELLAs. All together, these experiments demonstrated an intimate relationship between GA and auxin pathways in roots. Moreover, this crosstalk is mediated through two functionally related proteins in the two pathways (*AUX/IAA* and DELLAs). In addition to this direct effect, auxin has an indirect effect on DELLA proteins. Auxin treatment induces GA biosynthetic pathways and down-regulates *GA2ox*, an enzyme involved in the GA deactivation pathway (O'Neill and Ross 2002; Frigerio et al. 2006; Weiss and Ori 2007).

In seedlings, ET stabilized DELLA proteins, having a negative effect on GA signaling (Saibo et al. 2003; Achard et al. 2003; Vriezen et al. 2004). This negative effect is mediated by two important components of the ET signaling

pathway EIN3 and CTR1 (Achard et al. 2003; Vriezen et al. 2004). An antagonistic effect of ET on GA can also be found in mature plants. However, these effects seem to be mediated in a DELLA-independent manner. In mature plants, ET affects the level of bioactive GA (Achard et al. 2007a). Therefore, the effect of ET on DELLA in mature plants is rather indirect. Interestingly, positive effects between ET and GA have also been found. Apical hook formation in dark grown seedlings required both ET and GA. The biosynthetic mutant *gal-3* was not able to form an apical hook after ET treatment. Addition of GA or mutation of DELLA proteins (RGA or GAI) could restore this phenotype (Achard et al. 2003; Vriezen et al. 2004). Similarly, Saibo et al. (2003) demonstrated a synergistic effect between GA and ET. However, the role of DELLA proteins in this positive interaction between GA and ET is still unclear.

Cytokinins and GA are antagonistic (Jasinski et al. 2005; Greenboim-Wainberg et al. 2005; Brenner et al. 2005). This negative interaction has a biological meaning since function of GA and cytokinins are often opposite. The effect of cyto-

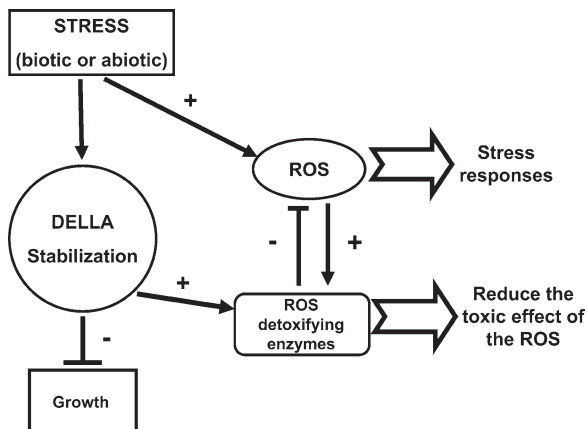

**Fig. 2.** Role of DELLA proteins during stress response. During stress, the plant cell induces the production of ROS. At the same time stresses stabilized DELLA proteins. Stabilization of DELLA proteins will repress the growth of the plant (—) and induce the expression of ROS detoxifying machinery. ROS have a double role during stress response. They act as signalling molecule and therefore promote stress responses. In addition, their toxicity damages the pathogen and the plant cell. The induction of the detoxifying machinery is required for the plant cell survival. +: induction; -: repression.

kinins on DELLA proteins is more indirect. This hormone inhibits the expression of two biosynthetic genes (GA20ox and GA3ox) and promotes the expression of negative regulators (GA2ox that deactivates GA and RGA and GAI that are two of the five DELLA proteins in *Arabidopsis*) (Brenner et al. 2005). Another point of interaction between cytokinins and GA signaling is given by KNOX1. KNOX1 is a transcription factor that promotes meristem function. This protein has a positive role in cytokinin biosynthesis and a negative role in GA biosynthesis (Jasinski et al. 2005).

As for cytokinins, developmental roles of ABA and GA are often antagonistic. Not surprisingly, Achard et al. (2006) demonstrated that ABA treatment stabilized DELLA protein even in the presence of GA. This experiment demonstrated a direct effect of ABA on DELLA proteins. Recently, Zentella et al. (2007) isolated putative DELLA direct targets. One of these targets is XERICICO. XERICICO is an H2-type RING E3 that controls ABA accumulation. The mechanism by which XERICICO controls ABA accumulation is still not clear. If over-expression of this protein induced high level of ABA, no induction of ABA biosynthetic genes could be detected (Zentella et al. 2002, 2007; Ko et al. 2006). Nevertheless, this data demonstrated that ABA antagonized the GA pathway by stabilizing DELLA proteins. Moreover, DELLA proteins seem to induce the expression of a positive regulator of ABA accumulation XERICICO. ABA could also act downstream of DELLA in barley aleurone (Gomez-Cadenas et al. 2001; Gubler et al. 2002). Finally, genetic evidence of the antagonistic effect between GA and ABA have been found. The ABA biosynthetic mutant *aba2* show an increase level of GA (Seo et al. 2006) and the GA biosynthetic mutant accumulates higher level of ABA (Oh et al. 2007).

Although the effects of different hormones on DELLA proteins have been tested, the role of DELLA proteins in response to stress is still not well studied. In 2006, Achard et al. (2006) demonstrated that in addition of ABA, NaCl treatment can stabilize DELLA proteins even in the presence of GA. Similarly, using either deletion mutants belonging to four out of the five DELLA proteins in *Arabidopsis* or gain of function mutants, they demonstrated that high level of DELLA proteins is correlated with salt stress tolerance; whereas

low levels of DELLA protein increase the plant susceptibility to the same stress.

The role of DELLA proteins in plant pathogen interactions is still not understood. However, an indirect effect on DELLA has been observed. *Gibberella fujikuroi*, the causal agent of the ‘bakanae’ disease of rice, produces GA. The GA produced by plant and pathogen is chemically similar and has similar effects on plant physiology. Because pathogens that are deficient in hormone synthesis (e.g., *G. fujikuroi* lacking GA-biosynthetic genes) do not display significant developmental alteration, it is probable that pathogens produce ‘phytohormones’ mainly to modulate the hormonal balance of their host, leading to the suppression of defense responses. Moreover, using GA mutants and over-expressor, Yang et al. (2008) showed that this hormone also affects the outcome of the plant pathogen interaction in rice. In this paper, the authors used elongated uppermost internode (*eui*) mutant and over-expressor plants. *EUI* encode a P450 protein that inactivated GA. Mutation of this gene results in an accumulation of bioactive GA and an elongation of the uppermost internode. In contrast, over-expression of the same gene results in GA deficiency, dwarfism and male sterility (Zhu et al. 2006). When they challenged *eui* rice mutants with either Xoo or *Magnaporthe grisea*, they observed an increase in susceptibility toward these two pathogens. As expected, the over-expression lines on the same gene showed an enhanced resistance against the same pathogens. Importantly, direct treatment of the plant with GA3 enhanced the disease susceptibility, whereas treatment with an inhibitor of GA biosynthesis increased resistance toward Xoo. The quantification of SA and JA revealed a decrease of JA in *eui* mutant and a decrease of SA in over-expressor lines. If the decrease of JA could partially explain the increased resistance against biotroph pathogens, the increased resistance observed in an *eui* over-expressor is independent of the SA.

DELLAs are the key regulators of the GA signaling pathway. Therefore, it is difficult to separate the direct effect of these proteins from the role of GA. Nevertheless, using mutants in four out of the five *Arabidopsis* DELLA proteins, Navarro et al. (2008) and Achard et al. (2008) further unravelled the role of DELLA in stress responses. Navarro et al. (2008) demonstrated that a DELLA quadruple

mutant is more susceptible to the necrotroph pathogen *Alternaria brassicicola* and more resistant to the biotroph pathogen PSTDC3000. Interestingly, Navarro et al. (2008) could correlate the differential response to pathogen with a mis-regulation of both SA and JA. In other words, they showed that in DELLA mutants, the induction of SA is stronger and faster than in the wild type plant. At the same time, the induction of JA is decreased. It is important to mention that no SA responsive genes are constitutively expressed. Therefore, it seems that the role of DELLAs in plant/pathogen interactions is to avoid an over-accumulation of stress-related compounds. In line with this hypothesis, Navarro et al. (2008) showed that infiltration of the virulent pathogen PSTDC3000 induced cell death only in DELLA mutants. Achard et al. (2008) took a different approach and examined microarray data after abiotic stress treatment (NaCl). Their analysis showed mutations of four out of five DELLA proteins decreased anti-oxidant gene induction, allowing the plant to accumulate more ROS. Therefore, Achard et al. (2008) also tested a necrotroph pathogen: *Botrytis cinerea*. As in the study published by Navarro et al. (2008) for *Alternaria brassicicola*, mutation of four DELLA proteins rendered the plant more susceptible to *Botrytis cinerea*. This data is in contradiction with the data published by Yang et al. (2008). In case of Navarro et al. (2008) and Achard et al. (2008), lack of DELLA increased the susceptibility against necrotroph pathogen and increases the resistance against a biotroph pathogen. In case of Yang et al. (2008), high GA promotes DELLA destabilization resulting in an increased susceptibility against biotroph pathogen. Therefore, the role of DELLA and of GA in general in disease resistance is still unclear. One possible explanation is that in rice endogenous SA is a positive regulator of ROS detoxification (Yang et al. 2004).

Altogether, these studies demonstrated that DELLA plays a central role in the “decision process”. These proteins are important negative regulators of plant growth and many stresses are able to stabilize them. In addition, virtually all hormones have direct or indirect impacts on their stability. Finally, DELLAs seems also to be important positive regulator of ROS detoxifying enzymes (Fig. 2). Perhaps, PIF or other HLH proteins are negative regulators of ROS detoxi-

fyng enzymes. Their exact role in stress is still not clear but it seems that DELLA proteins have an important role in balancing the stress response of the plant in both biotic and abiotic stress. The absence of these proteins results in the production of excess of stress signal (ROS) by the plant.

## VI Conclusions

Historically, the stress response was believed to be governed only by the so-called stress hormones (SA, JA, Ethylene and ABA). Even though these hormones have probably the most important effect on the response to stress, other hormones, previously described as developmental hormones (Auxin, GA, BR and Cytokinin), impact the stress response as well. The stress response is integrated and occurs in the entire organism. For example, drought stress is perceived in the roots and results in the closure of the stomata, a reduction of the photosynthesis in the leaves and in a general increase of the root to shoot ratio (Shao et al. 2008). The integration of the response requires the involvement of multiple hormones. Indeed, the plant could be seen as a complex machine where mis-function or alteration of one of its components results in broad set of consequences. Consistent with this view, Nemhauser et al. (2006) demonstrated that virtually all hormones have effects on each other's signalling outputs. Therefore, it is not surprising to see that interference with particular signalling pathways impacts the stress response.

Biotic and abiotic stress responses also interact and these two responses were believed to be antagonistic (Xiong and Yang 2003; Koga and Mori 2004; Mauch-Mani and Mauch 2005; Fujita et al. 2006; Robert-Seilaniantz et al. 2007). Moreover, much evidence shows that abiotic stress is prioritized over biotic stress response. However, the development of transcriptomics and bioinformatics tools demonstrated that the interaction between these two stress responses is more complex than just antagonistic. One possible hypothesis to explain stress responses is that the induction of any particular pathway is the consequence of the integration of different signals.

In contrast, following the conclusion of Nemhauser et al. (2006), stress responses seem to involve induction of a common set of genes by both types of stresses. In addition, specific genes

to each stress are induced either by the same signal or other signals. The combination of general and specific sets of genes could fine tune the response and lead to an appropriate response. It is worth noting that the inputs of different hormones are important to respond to stress in the most effective way. Consistent with that, all the stress hormones (ABA, JA and, to a lesser extent, SA) have a role in both biotic and abiotic stresses. The exact role or mechanism by which each hormone affects each type of stress is still under debate. The occasionally opposing role of hormones on stresses argues in favor of the integration of more than one signal. More than one signal or a sum of positive and negative signals would be a more appropriate view of the stress response.

Finally, the response observed, in any given experiment, often depends on both the timing and the type of tissue used. The complex crosstalk, between biotic and abiotic stresses and/or between hormones that researchers have begun to unravel, should be carefully evaluated over detailed time courses on a well-defined tissue. Plant-pathogen interactions are generally studied in leaves, yet the majority of hormone studies have been carried out on seedlings, roots, internodes or meristems. There is a shortage of information on the effects of most hormones on leaves. Development of techniques allowing a more homogenous tissue testing will probably give the community a clearer picture of the network of interactions.

### Box 6.1 Biotic Stress Pathways

Plant pathogens can be divided into two main categories depending on their lifestyles: biotroph (or hemibiotroph) and necrotroph pathogens. Biotrophic or hemibiotrophic pathogens keep their host alive and uptake nutrient from living tissues. This type of pathogens include *Pseudomonas syringae* and *Hyaloperonospora arabidopsidis* for example. On the other hand, necrotrophic pathogens kill their host plants and uptake nutrient from dead tissues. This type of pathogens include *Alternaria brassicicola* and *Botrytis cinerea*, for example.

To respond to these pathogens, plants have evolved two distinct pathways. The defense



**Box 6.1 (continued)**

responses against biotrophic pathogens are controlled by SA dependent pathway whereas the defense responses against necrotrophic pathogens are controlled by ET and JA dependent pathways. Importantly, those two pathways are antagonistic. Therefore, high resistance to biotrophic pathogen is correlated with high susceptibility to necrotrophic pathogens. Similarly, high resistance to necrotrophic pathogens is correlated with high susceptibility to biotrophic pathogens. This opposition between SA and JA/ET pathways is not only seen on their effect on pathogen responses, but also observed at the expression level of the genes regulated by these hormones.

**Acknowledgements**

We would like to thank members of the Jones laboratory and Mr. Ben Schwessinger for valuable comments on the manuscript. The Sainsbury Lab is funded by the Gatsby Charitable Foundation. A.R.S. and R.J. are funded by grants from the Biotechnology and Biological Sciences Research Council (BBSRC). We apologize to our colleagues whose work could not be cited in this review owing to space limitations.

**References**

- Achard P, Vriegen WH, Van Der Straeten D, Harberd NP (2003) Ethylene regulates *Arabidopsis* development via the modulation of DELLA protein growth repressor function. *Plant Cell* 15:2816–2825
- Achard P, Cheng H, De Grauwe L, Decat J, Schoutteten H, Moritz T, Van Der Straeten D, Peng J, Harberd NP (2006) Integration of plant responses to environmentally activated phytohormonal signals. *Science* 311:91–94
- Achard P, Baghour M, Chapple A, Hedden P, Van Der Straeten D, Genschik P, Moritz T, Harberd NP (2007a) The plant stress hormone ethylene controls floral transition via DELLA-dependent regulation of floral meristem-identity genes. *Proc Natl Acad Sci USA* 104:6484–6489
- Achard P, Liao L, Jiang C, Desnos T, Bartlett J, Fu X, Harberd NP (2007b) DELLAs contribute to plant photomorphogenesis. *Plant Physiol* 143:1163–1172
- Achard P, Renou JP, Berthome R, Harberd NP, Genschik P (2008) Plant DELLAs restrain growth and promote survival of adversity by reducing the levels of reactive oxygen species. *Curr Biol* 18:656–660
- Adie BA, Perez-Perez J, Perez-Perez MM, Godoy M, Sanchez-Serrano JJ, Schmelz EA, Solano R (2007) ABA is an essential signal for plant resistance to pathogens affecting JA biosynthesis and the activation of defenses in *Arabidopsis*. *Plant Cell* 19:1665–1681
- Agarwal PK, Agarwal P, Reddy MK, Sopory SK (2006) Role of DREB transcription factors in abiotic and biotic stress tolerance in plants. *Plant Cell Rep* 25:1263–1274
- Alvarez ME (2000) Salicylic acid in the machinery of hypersensitive cell death and disease resistance. *Plant Mol Biol* 44:429–442
- Alvarez S, Marsh EL, Schroeder SG, Schachtman DP (2008) Metabolomic and proteomic changes in the xylem sap of maize under drought. *Plant Cell Environ* 31:325–340
- Anderson JP, Badruzaufari E, Schenk PM, Manners JM, Desmond OJ, Ehlert C, Maclean DJ, Ebert PR, Kazan K (2004) Antagonistic interaction between abscisic acid and jasmonate-ethylene signaling pathways modulates defense gene expression and disease resistance in *Arabidopsis*. *Plant Cell* 16:3460–3479
- Apel K, Hirt H (2004) Reactive oxygen species: metabolism, oxidative stress and signal transduction. *Annu Rev Plant Biol* 55:373–399
- Asada K (1999) The water-water cycle in chloroplasts: scavenging of active oxygens and dissipation of excess photons. *Annu Rev Plant Physiol Mol Biol* 50:601–639
- Audenaert K, De Meyer GB, Hofte MM (2002) Abscisic acid determines basal susceptibility of tomato to *Botrytis cinerea* and suppresses salicylic acid-dependent signaling mechanisms. *Plant Physiol* 128:491–501
- Barrero JM, Piqueras P, Gonzalez-Guzman M, Serrano R, Rodriguez PL, Ponce MR, Micol JL (2005) A mutational analysis of the ABA1 gene of *Arabidopsis thaliana* highlights the involvement of ABA in vegetative development. *J Exp Bot* 56:2071–2083
- Barrero JM, Rodriguez PL, Quesada V, Alabadi D, Blazquez MA, Boutin JP, Marion-Poll A, Ponce MR, Micol JL (2008) The ABA1 gene and carotenoid biosynthesis are required for late skotomorphogenic growth in *Arabidopsis thaliana*. *Plant Cell Environ* 31:227–234
- Beaudoin N, Serizet C, Gosti F, Giraudat J (2000) Interactions between abscisic acid and ethylene signaling cascades. *Plant Cell* 12:1103–1115
- Bechtold U, Richard O, Zamboni A, Gapper C, Geisler M, Pogson B, Karpinski S, Mullineaux PM (2008) Impact of chloroplastic- and extracellular-sourced ROS on high light-responsive gene expression in *Arabidopsis*. *J Exp Bot* 59:121–133
- Bianco C, Imperlini E, Calogero R, Senatore B, Amoresano A, Carpentieri A, Pucci P, Defez R (2006a) Indole-3-acetic acid improves *Escherichia coli*'s defenses to stress. *Arch Microbiol* 185:373–382
- Bianco C, Imperlini E, Calogero R, Senatore B, Pucci P, Defez R (2006b) Indole-3-acetic acid regulates the central

- metabolic pathways in *Escherichia coli*. *Microbiology* 152:2421–2431
- Brandl MT, Lindow SE (1996) Cloning and characterization of a locus encoding an indolepyruvate decarboxylase involved in indole-3-acetic acid synthesis in *Erwinia herbicola*. *Appl Environ Microbiol* 62:4121–4128
- Brandl MT, Lindow SE (1998) Contribution of indole-3-acetic acid production to the epiphytic fitness of *Erwinia herbicola*. *Appl Environ Microbiol* 64:3256–3263
- Brandl MT, Quinones B, Lindow SE (2001) Heterogeneous transcription of an indole-acetic acid biosynthetic gene in *Erwinia herbicola* on plant surfaces. *Proc Natl Acad Sci USA* 98:3454–3459
- Brenner WG, Romanov GA, Kollmer I, Burkle L, Schmulding T (2005) Immediate-early and delayed cytokinin response genes of *Arabidopsis thaliana* identified by genome-wide expression profiling reveal novel cytokinin-sensitive processes and suggest cytokinin action through transcriptional cascades. *Plant J* 44:314–333
- Catinot J, Buchala A, Abou-Mansour E, Metraux JP (2008) Salicylic acid production in response to biotic and abiotic stress depends on isochorismate in *Nicotiana benthamiana*. *FEBS Lett* 582:473–478
- Chen J, Zhu C, Li LP, Sun ZY, Pan XB (2007) Effects of exogenous salicylic acid on growth and H<sub>2</sub>O<sub>2</sub>-metabolizing enzymes in rice seedlings under lead stress. *J Environ Sci (China)* 19:44–49
- Chini A, Grant JJ, Seki M, Shinozaki K, Loake GJ (2004) Drought tolerance established by enhanced expression of the CC-NBS-LRR gene, ADR1, requires salicylic acid, EDS1 and ABI1. *Plant J* 38:810–822
- Chini A, Fonseca S, Fernandez G, Adie B, Chico JM, Lorenzo O, García-Casado G, López-Vidriero I, Lozano FM, Ponce MR, Micol JL, Solano R (2007) The JAZ family of repressors is the missing link in *Jasmonate signaling*. *Nature* 448:666–671
- de Lucas M, Daviere JM, Rodriguez-Falcon M, Pontin M, Iglesias-Pedraz JM, Lorrain S, Fankhauser C, Blázquez MA, Titarenko E, Prat S (2008) A molecular framework for light and gibberellin control of cell elongation. *Nature* 451:480–484
- de Torres-Zabala M, Truman W, Bennett MH, Lafforgue G, Mansfield JW, Rodriguez Egea P, Bögre L, Grant M (2007) *Pseudomonas syringae* pv. tomato hijacks the *Arabidopsis* abscisic acid signalling pathway to cause disease. *EMBO J* 26:1434–1443
- Devoto A, Turner JG (2003) Regulation of jasmonate-mediated plant responses in *Arabidopsis*. *Ann Bot* 92:329–337
- Dhaubhadel S, Browning KS, Gallie DR, Krishna P (2002) Brassinosteroid functions to protect the translational machinery and heat-shock protein synthesis following thermal stress. *Plant J* 29:681–691
- Ding X, Cao Y, Huang L, Zhao J, Xu C, Li X, Wang S (2008) Activation of the indole-3-acetic acid-amido synthetase GH3-8 suppresses expansin expression and promotes salicylate- and jasmonate-independent basal immunity in rice. *Plant Cell* 20:228–240
- Donaldson RP, Luster DG (1991) Multiple forms of plant cytochromes P-450. *Plant Physiol* 96:669–674
- Draper J (1997) Salicylate, superoxide synthesis and cell suicide in plant defense. *Trends Plant Sci* 2:162–165
- Fedoroff NV (2002) Cross-talk in abscisic acid signaling. *Science STKE* 2002(140):RE10
- Feng S, Martinez C, Gusmaroli G, Wang Y, Zhou J, Wang F, Chen L, Yu L, Iglesias-Pedraz JM, Kircher S, Schäfer E, Fu X, Fan LM, Deng XW (2008) Coordinated regulation of *Arabidopsis thaliana* development by light and gibberellins. *Nature* 451:475–479
- Frigerio M, Alabadi D, Perez-Gomez J, Garcia-Carcel L, Phillips AL, Hedden P, Blázquez MA (2006) Transcriptional regulation of gibberellin metabolism genes by auxin signaling in *Arabidopsis*. *Plant Physiol* 142:553–563
- Fu X, Harberd NP (2003) Auxin promotes *Arabidopsis* root growth by modulating gibberellin response. *Nature* 421:740–743
- Fujita M, Fujita Y, Noutoshi Y, Takahashi F, Narusaka Y, Yamaguchi-Shinozaki K, Shinozaki K (2006) Crosstalk between abiotic and biotic stress responses: a current view from the points of convergence in the stress signaling networks. *Curr Opin Plant Biol* 9:436–442
- Glawischnig E (2006) The role of cytochrome P450 enzymes in the biosynthesis of camalexin. *Biochem Soc Trans* 34:1206–1208
- Glickmann E, Gardan L, Jacquet S, Hussain S, Elasri M, Petit A, Dessaux Y (1998) Auxin production is a common feature of most pathovars of *Pseudomonas syringae*. *Mol Plant Microbe Interact* 11:156–162
- Glombitza S, Dubuis PH, Thulke O, Welzl G, Bovet L, Götz M, Affenzeller M, Geist B, Hehn A, Asnaghi C, Ernst D, Seidlitz HK, Gundlach H, Mayer KF, Martinoia E, Werck-Reichhart D, Mauch F, Schäffner AR (2004) Crosstalk and differential response to abiotic and biotic stressors reflected at the transcriptional level of effector genes from secondary metabolism. *Plant Mol Biol* 54:817–835
- Goel AK, Lundberg D, Torres MA, Matthews R, Akimoto-Tomiya C, Farmer L, Dangel JL, Grant SR (2008) The *Pseudomonas syringae* type III effector HopAM1 enhances virulence on water-stressed plants. *Mol Plant Microbe Interact* 21:361–370
- Goethals K, Vereecke D, Jaziri M, Van Montagu M, Holsters M (2001) Leafy gall formation by *Rhodococcus fascians*. *Annu Rev Phytopathol* 39:27–52
- Gols R, Roosjen M, Dijkman H, Dicke M (2003) Induction of direct and indirect plant responses by jasmonic acid, low spider mite densities or a combination of jasmonic acid treatment and spider mite infestation. *J Chem Ecol* 29:2651–2666
- Gomez-Cadenas A, Zentella R, Walker-Simmons MK, Ho TH (2001) Gibberellin/abscisic acid antagonism in barley aleurone cells: site of action of the protein kinase PKABA1 in relation to gibberellin signaling molecules. *Plant Cell* 13:667–679
- Gomez-Gomez L, Boller T (2000) FLS2: an LRR receptor-like kinase involved in the perception of the bacterial elicitor flagellin in *Arabidopsis*. *Mol Cell* 5:1003–1011

- Gomez-Gomez L, Bauer Z, Boller T (2001) Both the extracellular leucine-rich repeat domain and the kinase activity of FSL2 are required for flagellin binding and signaling in *Arabidopsis*. *Plant Cell* 13:1155–1163
- Greenboim-Wainberg Y, Maymon I, Borochof R, Alvarez J, Olszewski N, Ori N, Eshed Y, Weiss D (2005) Cross talk between gibberellin and cytokinin: the *Arabidopsis* GA response inhibitor SPINDLY plays a positive role in cytokinin signaling. *Plant Cell* 17:92–102
- Gubler F, Chandler PM, White RG, Llewellyn DJ, Jacobsen JV (2002) Gibberellin signaling in barley aleurone cells, control of SLN1 and GAMYB expression. *Plant Physiol* 129:191–200
- Gunes A, Inal A, Alpaslan M, Eraslan F, Bagci EG, Cicek N (2007) Salicylic acid induced changes on some physiological parameters symptomatic for oxidative stress and mineral nutrition in maize (*Zea mays* L.) grown under salinity. *J Plant Physiol* 164:728–736
- Halim VA, Vess A, Scheel D, Rosahl S (2006) The role of salicylic acid and jasmonic acid in pathogen defense. *Plant Biol (Stuttg)* 8:307–313
- Harberd NP (2003) Botany, relieving DELLA restraint. *Science* 299:1853–1854
- Haubrick LL, Assmann SM (2006) Brassinosteroids and plant function: some clues, more puzzles. *Plant Cell Environ* 29:446–457
- Havlova M, Dobrev PI, Motyka V, Storchova H, Libus J, Dobrá J, Malbeck J, Gaudinová A, Vanková R (2008) The role of cytokinins in responses to water deficit in tobacco plants over-expressing trans-zeatin O-glucosyltransferase gene under 35S or SAG12 promoters. *Plant Cell Environ* 31:341–353
- He XJ, Mu RL, Cao WH, Zhang ZG, Zhang JS, Chen SY (2005) AtNAC2, a transcription factor downstream of ethylene and auxin signaling pathways, is involved in salt stress response and lateral root development. *Plant J* 44:903–916
- Hirai N, Yoshida R, Todoroki Y, Ohigashi H (2000) Biosynthesis of abscisic acid by the non-mevalonate pathway in plants, and by the mevalonate pathway in fungi. *Biosci Biotechnol Biochem* 64:1448–1458
- Hirayama T, Shinozaki K (2007) Perception and transduction of abscisic acid signals: keys to the function of the versatile plant hormone ABA. *Trends Plant Sci* 12:343–351
- Huq E, Quail PH (2002) PIF4, a phytochrome-interacting bHLH factor, functions as a negative regulator of phytochrome B signaling in *Arabidopsis*. *EMBO J* 21:2441–2450
- Igari K, Endo S, Hibara K, Aida M, Sakakibara H, Kawasaki T, Tasaka M (2008) Constitutive activation of a CC-NB-LRR protein alters morphogenesis through the cytokinin pathway in *Arabidopsis*. *Plant J* 55(1):14–27
- Inomata M, Hirai N, Yoshida R, Ohigashi H (2004) The biosynthetic pathway to abscisic acid via ionylideneethane in the fungus *Botrytis cinerea*. *Phytochemistry* 65:2667–2678
- Jager CE, Symons GM, Ross JJ, Reid JB (2008) Do brassinosteroids mediate the water stress response? *Physiol Plant* 133:417–425
- Jasinski S, Piazza P, Craft J, Hay A, Woolley L, Rieu I, Phillips A, Hedden P, Tsiantis M (2005) KNOX action in *Arabidopsis* is mediated by coordinate regulation of cytokinin and gibberellin activities. *Curr Biol* 15:1560–1565
- Jiang C, Fu X (2007) GA action: turning on de-DELLA repressing signaling. *Curr Opin Plant Biol* 10:461–465
- Kagale S, Divi UK, Krochko JE, Keller WA, Krishna P (2007) Brassinosteroid confers tolerance in *Arabidopsis thaliana* and *Brassica napus* to a range of abiotic stresses. *Planta* 225:353–364
- Kariola T, Brader G, Helenius E, Li J, Heino P, Palva ET (2006) Early responsive to dehydration, a negative regulator of abscisic acid responses in *Arabidopsis*. *Plant Physiol* 142:1559–1573
- Katsir L, Schilmiller AL, Staswick PE, He SY, Howe GA (2008) COI1 is a critical component of a receptor for jasmonate and the bacterial virulence factor coronatine. *Proc Natl Acad Sci USA* 105:7100–7105
- Kim J, Yi H, Choi G, Shin B, Song PS, Choi G (2003) Functional characterization of phytochrome interacting factor 3 in phytochrome-mediated light signal transduction. *Plant Cell* 15:2399–2407
- Ko JH, Yang SH, Han KH (2006) Upregulation of an *Arabidopsis* RING-H2 gene, XERICO, confers drought tolerance through increased abscisic acid biosynthesis. *Plant J* 47:343–355
- Koga H, Dohi K and Mori M (2004) Abscisic acid and low temperatures suppress the whole plant-specific resistance reaction of rice plants to the infection of *Magnaporthe grisea*. *Physiol Mol Plant Path* 65:3–9
- Krishna P (2003) Brassinosteroid-mediated stress responses. *J Plant Growth Regul* 22:289–297
- Kunkel BN, Brooks DM (2002) Cross talk between signaling pathways in pathogen defense. *Curr Opin Plant Biol* 5:325–331
- Kwak JM, Mori IC, Pei ZM, Leonhardt N, Torres MA, Dangl JL, Bloom RE, Bodde S, Jones JD, Schroeder JI (2003) NADPH oxidase AtrbohD and AtrbohF genes function in ROS-dependent ABA signaling in *Arabidopsis*. *EMBO J* 22:2623–2633
- Lauric-Berry N, Joardar V, Street IH, Kunkel BN (2006) The *Arabidopsis thaliana* jasmonate insensitive 1 gene is required for suppression of salicylic acid-dependent defenses during infection by *Pseudomonas syringae*. *Mol Plant Microbe Interact* 19:789–800
- Lichter A, Barash I, Valinsky L, Manulis S (1995) The genes involved in cytokinin biosynthesis in *Erwinia herbicola* pv. gypsophilae: characterization and role in gall formation. *J Bacteriol* 177:4457–4465
- Liu X, Yue Y, Li B, Nie Y, Li W, Wu WH, Ma L (2007) A G-protein coupled receptor is a plasma membrane receptor for the plant hormone abscisic acid. *Science* 315:1712–1716
- Llorente FMP, Sánchez-Vallet A, López G, Ramos B, Sánchez-Rodríguez C, Jordá L, Parker J, Molina A (2008) Repression of the auxin response pathway increases *Arabidopsis* susceptibility to necrotrophic fungi. *Mol Plant* 1:496–509

- Ma S, Bohnert HJ (2007) Integration of *Arabidopsis thaliana* stress-related transcript profiles, promoter structures and cell-specific expression. *Genome Biol* 8:R49
- Ma S, Bohnert HJ (2008) Gene networks in *Arabidopsis thaliana* for metabolic and environmental functions. *Mol Biosyst* 4:199–204
- Manulis S, Haviv-Chesner A, Brandl MT, Lindow SE, Barash I (1998) Differential involvement of indole-3-acetic acid biosynthetic pathways in pathogenicity and epiphytic fitness of *Erwinia herbicola* pv. *gypsophilae*. *Mol Plant Microbe Interact* 11:634–642
- Maor R, Haskin S, Levi-Kedmi H, Sharon A (2004) *In planta* production of indole-3-acetic acid by *Colletotrichum gloeosporioides* f. sp. *aeschyromene*. *Appl Environ Microbiol* 70:1852–1854
- Mateo A, Funck D, Muhlenbock P, Kular B, Mullineaux PM, Karpinski S (2006) Controlled levels of salicylic acid are required for optimal photosynthesis and redox homeostasis. *J Exp Bot* 57:1795–1807
- Mauch-Mani B, Mauch F (2005) The role of abscisic acid in plant-pathogen interactions. *Curr Opin Plant Biol* 8:409–414
- Mazzola M, White FF (1994) A mutation in the indole-3-acetic acid biosynthesis pathway of *Pseudomonas syringae* pv. *syringae* affects growth in *Phaseolus vulgaris* and syringomycin production. *J Bacteriol* 176:1374–1382
- Melotto M, Underwood W, Koczan J, Nomura K, He SY (2006) Plant stomata function in innate immunity against bacterial invasion. *Cell* 126:969–980
- Melotto M, Mecey C, Niu Y, Chung HS, Katsir L, Yao J, Zeng W, Thines B, Staswick P, Browse J, Howe GA, He SY (2008) A critical role of two positively charged amino acids in the Jas motif of *Arabidopsis* JAZ proteins in mediating coronatine- and jasmonoyl isoleucine-dependent interaction with the COI1 F-box protein. *Plant J* 55:979–988
- Metwally A, Finkemeier I, Georgi M, Dietz KJ (2003) Salicylic acid alleviates the cadmium toxicity in barley seedlings. *Plant Physiol* 132:272–281
- Mohr PG, Cahill DM (2003) Abscisic acid influences the susceptibility of *Arabidopsis thaliana* to *Pseudomonas syringae* pv. *tomato* and *Peronospora parasitica*. *Funct Plant Biol* 30:461–469
- Mohr PG, Cahill DM (2006) Suppression by ABA of salicylic acid and lignin accumulation and the expression of multiple genes, in *Arabidopsis* infected with *Pseudomonas syringae* pv. *tomato*. *Funct Integr Genomics* 7:181–191
- Mou Z, Fan W, Dong X (2003) Inducers of plant systemic acquired resistance regulate NPR1 function through redox changes. *Cell* 113:935–944
- Murphy AM, Pryce-Jones E, Johnstone K, Ashby AM (1997) Comparison of cytokinin production *in vitro* by *Pyrenopeziza brassicae* with other plant pathogens. *Physiol Mol Plant Pathol* 50:53–65
- Nafisi M, Goregaoker S, Botanga CJ, Glawischnig E, Olsen CE, Halkier BA, Glazebrook J (2007) *Arabidopsis* cytochrome P450 monooxygenase 71A13 catalyzes the conversion of indole-3-acetaldoxime in camalexin synthesis. *Plant Cell* 19:2039–2052
- Nakashita H, Yasuda M, Nitta T, Asami T, Fujioka S, Arai Y, Sekimata K, Takatsuto S, Yamaguchi I, Yoshida S (2003) Brassinosteroid functions in a broad range of disease resistance in tobacco and rice. *Plant J* 33:887–898
- Narusaka Y, Narusaka M, Seki M, Umezawa T, Ishida J, Nakajima M, Enju A, Shinozaki K (2004) Crosstalk in the responses to abiotic and biotic stresses in *Arabidopsis*: analysis of gene expression in cytochrome P450 gene superfamily by cDNA microarray. *Plant Mol Biol* 55:327–342
- Navarro L, Zipfel C, Rowland O, Keller I, Robatzek S, Boller T, Jones JD (2004) The transcriptional innate immune response to flg22. Interplay and overlap with Avr gene-dependent defense responses and bacterial pathogenesis. *Plant Physiol* 135:1113–1128
- Navarro L, Dunoyer P, Jay F, Arnold B, Dharmasiri N, Estelle M, Voinnet O, Jones JD (2006) A plant miRNA contributes to antibacterial resistance by repressing auxin signaling. *Science* 312:436–439
- Navarro L, Bari R, Achard P, Lison P, Nemri A, Harberd NP, Jones JD (2008) DELLAs control plant immune responses by modulating the balance of jasmonic acid and salicylic acid signaling. *Curr Biol* 18:650–655
- Nemhauser JL, Hong F, Chory J (2006) Different plant hormones regulate similar processes through largely non-overlapping transcriptional responses. *Cell* 126:467–475
- O'Donnell PJ, Schmelz EA, Moussatche P, Lund ST, Jones JB, Klee HJ (2003a) Susceptible to intolerance—a range of hormonal actions in a susceptible *Arabidopsis* pathogen response. *Plant J* 33:245–257
- O'Donnell PJ, Schmelz E, Block A, Miersch O, Wasternack C, Jones JB, Klee HJ (2003b) Multiple hormones act sequentially to mediate a susceptible tomato pathogen defense response. *Plant Physiol* 133:1181–1189
- O'Neill DP, Ross JJ (2002) Auxin regulation of the gibberellin pathway in pea. *Plant Physiol* 130:1974–1982
- Oh E, Yamaguchi S, Hu J, Yusuke J, Jung B, Paik I, Lee HS, Sun TP, Kamiya Y, Choi G (2007) PIL5, a phytochrome-interacting bHLH protein, regulates gibberellin responsiveness by binding directly to the GAI and RGA promoters in *Arabidopsis* seeds. *Plant Cell* 19:1192–1208
- Overmyer K, Brosche M, Kangasjarvi J (2003) Reactive oxygen species and hormonal control of cell death. *Trends Plant Sci* 8:335–342
- Palm CJ, Gaffney T, Kosuge T (1989) Co-transcription of genes encoding indole-acetic acid production in *Pseudomonas syringae* subsp. *savastanoi*. *J Bacteriol* 171:1002–1009
- Park JE, Park JY, Kim YS, Staswick PE, Jeon J, Yun J, Kim SY, Kim J, Lee YH, Park CM (2007) GH3-mediated auxin homeostasis links growth regulation with stress adaptation response in *Arabidopsis*. *J Biol Chem* 282:10036–10046
- Parry G, Estelle M (2006) Auxin receptors: a new role for F-box proteins. *Curr Opin Cell Biol* 18:152–156



- Penninckx IA, Eggermont K, Terras FR, Thomma BP, De Samblanx GW, Buchala A, Métraux JP, Manners JM, Broekaert WF (1996) Pathogen-induced systemic activation of a plant defense gene in *Arabidopsis* follows a salicylic acid-independent pathway. *Plant Cell* 8:2309–2323
- Porta H, Rueda-Benitez P, Campos F, Colmenero-Flores JM, Colorado JM, Carmona MJ, Covarrubias AA, Rochasosa M (1999) Analysis of lipoxygenase mRNA accumulation in the common bean (*Phaseolus vulgaris* L.) during development and under stress conditions. *Plant Cell Physiol* 40:850–858
- Pospisiłova JBP (2004) Effects of pre-treatments with abscisic acid and/or benzyladenine on gas exchange of French bean, sugar beet and maize leaves during water stress and after rehydration. *BiolPlantarum* 48:395–399
- Quint M, Gray WM (2006) Auxin signaling. *Curr Opin Plant Biol* 9:448–453
- Razem FA, El-Kereamy A, Abrams SR, Hill RD (2006) The RNA-binding protein FCA is an abscisic acid receptor. *Nature* 439:290–294
- Ren D, Liu Y, Yang KY, Han L, Mao G, Glazebrook J, Zhang S (2008) A fungal-responsive MAPK cascade regulates phytoalexin biosynthesis in *Arabidopsis*. *Proc Natl Acad Sci USA* 105:5638–5643
- Robert-Seilaniantz A, Navarro L, Bari R, Jones JD (2007) Pathological hormone imbalances. *Curr Opin Plant Biol* 10:372–379
- Robinette D, Matthyse AG (1990) Inhibition by *Agrobacterium tumefaciens* and *Pseudomonas savastanoi* of development of the hypersensitive response elicited by *Pseudomonas syringae* pv. phaseolicola. *J Bacteriol* 172:5742–5749
- Saibo NJ, Vriezen WH, Beemster GT, Van Der Straeten D (2003) Growth and stomata development of *Arabidopsis* hypocotyls are controlled by gibberellins and modulated by ethylene and auxins. *Plant J* 33:989–1000
- Sasaki-Sekimoto Y, Taki N, Obayashi T, Aono M, Matsumoto F, Sakurai N, Suzuki H, Hirai MY, Noji M, Saito K, Masuda T, Takamiya K, Shibata D, Ohta H (2005) Coordinated activation of metabolic pathways for antioxidants and defense compounds by jasmonates and their roles in stress tolerance in *Arabidopsis*. *Plant J* 44:653–668
- Schenk PM, Kazan K, Wilson I, Anderson JP, Richmond T, Somerville SC, Manners JM (2000) Coordinated plant defense responses in *Arabidopsis* revealed by microarray analysis. *Proc Natl Acad Sci USA* 97:11655–11660
- Schmelz EA, Engelberth J, Alborn HT, O'Donnell P, Sammons M, Toshima H, Tumlinson JH 3rd (2003) Simultaneous analysis of phytohormones, phytotoxins and volatile organic compounds in plants. *Proc Natl Acad Sci USA* 100:10552–10557
- Schwechheimer C (2008) Understanding gibberellic acid signaling – are we there yet? *Curr Opin Plant Biol* 11:9–15
- Seo M, Hanada A, Kuwahara A, Endo A, Okamoto M, Yamauchi Y, North H, Marion-Poll A, Sun TP, Koshiba T, Kamiya Y, Yamaguchi S, Nambara E (2006) Regulation of hormone metabolism in *Arabidopsis* seeds: phytochrome regulation of abscisic acid metabolism and abscisic acid regulation of gibberellin metabolism. *Plant J* 48:354–366
- Seo PJ, Lee AK, Xiang F, Park CM (2008) Molecular and functional profiling of *Arabidopsis* pathogenesis-related genes: insights into their roles in salt response of seed germination. *Plant Cell Physiol* 49:334–344
- Shao HB, Chu LY, Jaleel CA, Zhao CX (2008) Water-deficit stress-induced anatomical changes in higher plants. *CR Biol* 331:215–225
- Shen YY, Wang XF, Wu FQ, Du SY, Cao Z, Shang Y, Wang XL, Peng CC, Yu XC, Zhu SY, Fan RC, Xu YH, Zhang DP (2006) The Mg-chelatase H subunit is an abscisic acid receptor. *Nature* 443:823–826
- Staswick PE (2008) JAZZing up jasmonate signaling. *Trends Plant Sci* 13:66–71
- Staswick PE, Tiryaki I, Rowe ML (2002) Jasmonate response locus JAR1 and several related *Arabidopsis* genes encode enzymes of the firefly luciferase superfamily that show activity on jasmonic, salicylic, and indole-3-acetic acids in an assay for adenylation. *Plant Cell* 14:1405–1415
- Sunkar R, Zhu JK (2004) Novel and stress-regulated microRNAs and other small RNAs from *Arabidopsis*. *Plant Cell* 16:2001–2019
- Takahashi S, Seki M, Ishida J, Satou M, Sakurai T, Narusaka M, Kamiya A, Nakajima M, Enju A, Akiyama K, Yamaguchi-Shinozaki K, Shinozaki K (2004) Monitoring the expression profiles of genes induced by hyperosmotic, high salinity, and oxidative stress and abscisic acid treatment in *Arabidopsis* cell culture using a full-length cDNA microarray. *Plant Mol Biol* 56:29–55
- Thines B, Katsir L, Melotto M, Niu Y, Mandaokar A, Liu G, Nomura K, He SY, Howe GA, Browse J (2007) JAZ repressor proteins are targets of the SCF(COI1) complex during jasmonate signalling. *Nature* 448:661–665
- Torres MA, Jones JD, Dangl JL (2006) Reactive oxygen species signaling in response to pathogens. *Plant Physiol* 141:373–378
- Truman W, de Zabala MT, Grant M (2006) Type III effectors orchestrate a complex interplay between transcriptional networks to modify basal defense responses during pathogenesis and resistance. *Plant J* 46:14–33
- Valls M, Genin S, Boucher C (2006) Integrated regulation of the type III secretion system and other virulence determinants in *Ralstonia solanacearum*. *PLoS Pathog* 2(8):e82
- Verlues PE, Zhu JK (2005) Before and beyond ABA: upstream sensing and internal signals that determine ABA accumulation and response under abiotic stress. *Biochem Soc Trans* 33:375–379
- Vriezen WH, Achard P, Harberd NP, Van Der Straeten D (2004) Ethylene-mediated enhancement of apical hook formation in etiolated *Arabidopsis thaliana* seedlings is gibberellin dependent. *Plant J* 37:505–516
- Walters DR, McRoberts N (2006) Plants and biotrophs: a pivotal role for cytokinins? *Trends Plant Sci* 11:581–586

- Walters DR, McRoberts N, Fitt BD (2008) Are green islands red herrings? Significance of green islands in plant interactions with pathogens and pests. *Biol Rev Camb Philos Soc* 83:79–102
- Wang D, Pajeroska-Mukhtar K, Culler AH, Dong X (2007a) Salicylic acid inhibits pathogen growth in plants through repression of the auxin signaling pathway. *Curr Biol* 17:1784–1790
- Wang Y, Liu C, Li K, Sun F, Hu H, Li X, Zhao Y, Han C, Zhang W, Duan Y, Liu M, Li X (2007b) *Arabidopsis* EIN2 modulates stress response through abscisic acid response pathway. *Plant Mol Biol* 64:633–644
- Weiss D, Ori N (2007) Mechanisms of cross talk between gibberellin and other hormones. *Plant Physiol* 144:1240–1246
- Xiong L, Yang Y (2003) Disease resistance and abiotic stress tolerance in rice are inversely modulated by an abscisic acid-inducible mitogen-activated protein kinase. *Plant Cell* 15:745–759
- Yamaguchi-Shinozaki K, Shinozaki K (2005) Organization of cis-acting regulatory elements in osmotic- and cold-stress responsive promoters. *Trends Plant Sci* 10:88–94
- Yan J, Tsuchihara N, Etoh T, Iwai S (2007) Reactive oxygen species and nitric oxide are involved in ABA inhibition of stomatal opening. *Plant Cell Environ* 30:1320–1325
- Yang Y, Qi M, Mei C (2004) Endogenous salicylic acid protects rice plants from oxidative damage caused by aging as well as biotic and abiotic stress. *Plant J* 40:909–919
- Yang DLQ, Deng YW, Lou YG, Wang MY, Zhou GY, Zhang YY, He ZH (2008) Altered disease development in the eui mutants and eui over-expressors indicates that gibberellins negatively regulate rice basal disease resistance. *Mol Plant* 1:528–537
- Zentella R, Yamauchi D, Ho TH (2002) Molecular dissection of the gibberellin/abscisic acid signaling pathways by transiently expressed RNA interference in barley aleurone cell. *Plant Cell* 14:2289–2301
- Zentella R, Zhang ZL, Park M, Thomas SG, Endo A, Murase K, Fleet CM, Jikumaru Y, Nambara E, Kamiya Y, Sun TP (2007) Global analysis of DELLA direct targets in early gibberellin signaling in *Arabidopsis*. *Plant Cell* 19:3037–3057
- Zhao J, Williams CC, Last RL (1998) Induction of *Arabidopsis* tryptophan pathway enzymes and camalexin by amino acid starvation, oxidative stress and an abiotic elicitor. *Plant Cell* 10:359–370
- Zhu Y, Nomura T, Xu Y, Zhang Y, Peng Y, Mao B, Hanada A, Zhou H, Wang R, Li P, Zhu X, Mander LN, Kamiya Y, Yamaguchi S, He Z (2006) Elongated uppermost internode encodes a cytochrome P450 monooxygenase that epoxidizes gibberellins in a novel deactivation reaction in rice. *Plant Cell* 18:442–456
- Zipfel C, Robatzek S, Navarro L, Oakeley EJ, Jones JD, Felix G, Boller T (2004) Bacterial disease resistance in *Arabidopsis* through flagellin perception. *Nature* 428:764–767

## Protein Kinases and Phosphatases for Stress Signal Transduction in Plants<sup>1</sup>

Lee Chae and Sheng Luan\*

*Department of Plant and Microbial Biology, University of California,  
Berkeley, CA 94720, USA*

Girdhar K Pandey

*Department of Plant Molecular Biology, University of Delhi South Campus,  
Benito Juarez Road, New Delhi-110021, India*

Yong Hwa Cheong

*Department of Bio-Environmental Science, Suncheon National University,  
Suncheon, Jeonnam 540-742, Korea*

Kyung-Nam Kim

*Department of Molecular Biology, Sejong University, Seoul 143-747, Korea*

Summary .....	124
I Introduction.....	125
II Receptor-Like Kinases .....	125
A Gene Families .....	125
B Functions.....	128
1 Disease Resistance.....	128
2 Hormone Signaling.....	130
3 Plant Development.....	131
III Mitogen Activated Protein (MAP) Kinases and MAPK Cascades .....	132
A Gene Families .....	132
1 MAPKs .....	132
2 MAPKKs .....	133
3 MAPKKKs.....	134
B Functions.....	134
1 Disease Resistance.....	134
2 Hormone Signaling.....	137
3 Abiotic Stress Signaling.....	138
IV Calcium-Activated Protein Kinases .....	138
A Gene Families .....	139
1 CDPKs.....	139
2 CRKs .....	140
3 CCaMKs and CaMKs .....	140
4 CIPKs and CBLs .....	140

\* Author for correspondence, e-mail: sluan@nature.berkeley.edu

<sup>1</sup>Lee Chae, Yong Hwa Cheong, Kyung-Nam Kim, and Girdhar K. Pandey have contributed equally to this chapter.

B	Functions of the CBL–CIPK Complexes .....	142
1	Osmotic Stress .....	142
2	Potassium Deficiency .....	143
3	High pH .....	143
4	Salt Stress .....	143
5	Novel Stress-Related Interactions .....	144
V	Protein Phosphatases .....	145
A	Gene Families .....	145
1	Protein Phosphatase P .....	145
2	Protein Phosphatase M .....	147
3	Protein Tyrosine Phosphatases .....	147
B	Functions.....	148
1	Hormone Signaling and Development.....	148
2	MAPK Interactions.....	149
3	Novel Interactions.....	149
VI	Conclusions.....	150
	Acknowledgements .....	150
	References .....	150

## Summary

Adverse environmental conditions that threaten plant growth and development are known as environmental stresses. To survive stress, plants employ a complex set of distinct signaling pathways that trigger stress-specific tolerance or avoidance in the organism as a whole. An important biochemical mechanism for regulating such pathways is reversible protein phosphorylation. In this process, the activity of a pathway is modulated through either the addition or removal of phosphate groups to individual pathway components. Protein kinases and protein phosphatases often act in tandem to perform the phosphorylation and de-phosphorylation process. Here, we'll review recent progress made in understanding several of the large gene families that encode protein kinases and phosphatases involved in stress signaling in plants. In particular, we discuss the receptor-like kinase, mitogen-activated protein kinases, and calcium-regulated protein kinase gene families, as well as the three major phosphatase-related gene families: protein phosphatase P, protein phosphatase M, and protein tyrosine phosphatases.

**Keywords:** development • hormone signaling • kinase • MAPK • phosphatase

*Abbreviations:* AtPTP – tyrosine specific PTP; BR – brassinosteroids; BRI – brassinosteroid insensitive; CaM – calmodulin; CaMKs – CaM-dependent protein kinases; CBLs – calcineurin B-like proteins; CCaMKs – calcium and calmodulin dependent kinase; CDPKs – calcium dependent protein kinases; CHRK1 – chitinase receptor kinase 1; CIPKs – CBL-interacting protein kinases; CLV – 1 clavata 1; dsPTPs – dual specificity phosphatases; EDR1 – enhanced disease resistance; EGF – epidermal growth factor; EMS1 – excess micro-sporocytes; ERK – extracellular signal regulated kinase; EREBPs – ethylene responsive element binding proteins; EXS – extra sporogenous cells; FHA – forkhead-associated domain; FLS-2 – flagellin-sensitive 2; GmNARK – soybean

nodule autoregulator receptor kinase; HAR – hypermodulation aberrant root; HR – hypersensitive response; JA – jasmonic acid; KAPP – kinase associated protein phosphatase; LRR – leucine-rich repeat; MAPK – mitogen-activated protein kinase; NORK – nodulation receptor kinase; OMTK – 1 oxidative stress-activated MAP triple kinase 1; PP2C – 2C-protein phosphatases; POL – poltergeist phosphatase gene; PPM – protein phosphatase M; PPP – protein phosphatase P; PR – pathogen related; PTP – protein tyrosine phosphatase; RLKs – plant receptor-like kinases; ROS – reactive oxygen species; RTKs – receptor tyrosine kinases; SA – salicylic acid; SYMRK – symbiosis receptor-like kinase; TNFR – tumor necrosis factor receptor; WAK – wall associated kinase



## I Introduction

Plants rely on environmental cues to guide their developmental and physiological programs. For example, light quality and duration, ambient temperature, water status, and nutrient availability are just a few of the many signals plants must interpret accurately in order to prosper (Wang et al. 2003). Extreme changes in environmental conditions often threaten plant viability. Such adverse conditions are known as environmental stresses and fall into one of two categories: abiotic stress or biotic stress. Abiotic stresses are chemically or physically derived, and include such conditions as drought, excessive salinity, mineral deficiencies, and heavy metal contamination (Vinocur and Altman 2005). Biotic stresses, such as disease and wounding, are wrought by other organisms, including bacteria, viruses, insects and nematodes (Peck 2003).

As a whole, environmental stresses are a major cause of crop loss worldwide, as well as a fundamental threat to the natural plant life that support so many of the world's ecosystems. For this reason, a critical goal in plant science is to understand how plants sense and combat environmental stresses. On a cellular level, the response to stress involves perceiving the stress signal, relaying the information to the appropriate intracellular targets, and triggering the necessary biophysical and molecular adaptations that result in stress tolerance and avoidance in the organism as a whole. The molecules involved in this process comprise a signal transduction pathway, and research to date has made it clear that plants employ a complex array of such pathways to handle the environmental stresses they encounter.

An important biochemical event involved in many of these pathways is protein phosphorylation. During protein phosphorylation, a protein kinase either activates or de-activates a substrate through the addition of a phosphate group, thereby propagating or regulating a signal. Protein phosphatases reverse the effect by removing the phosphate from the substrate. In this chapter, we focus on the families of protein kinases and phosphatases that provide this core functionality in many stress-related signal transduction pathways in plants. We review the major gene and protein families that encode protein kinases and phosphatases in plants, and how they differ

from other eukaryotic systems. Also, we discuss the results of ongoing research efforts to understand the functionality of these families, as well as the signal transduction pathways in which they participate and their overall involvement in plant stress perception and response.

## II Receptor-Like Kinases

Plant receptor-like kinases (RLKs) are a class of single-pass transmembrane proteins with N-terminal extracellular domains and C-terminal cytoplasmic kinase domains. The configuration of these domains is similar to the domain organization found in mammalian receptor tyrosine kinases (RTKs), which act as cell surface receptors for a wide variety of ligands, including growth factors, hormones and cytokines (Walker and Zhang 1990; Morris and Walker 2003; Johnson and Ingram 2005). Likewise, plant RLKs are speculated to act as cell surface receptors for many plant signaling pathways. However, plant RLKs are serine/threonine kinases, as opposed to the tyrosine-specific kinases found in the mammalian RTKs.

Collectively, RLKs comprise the largest family of receptors in plants. More than 1,100 RLKs have been identified in the rice genome, while the *Arabidopsis* genome contains more than 610 RLK genes. Of the *Arabidopsis* RLKs, 417 appear to encode full-length RLKs consisting of extracellular domains, a transmembrane domain, and a cytoplasmic kinase domain (Fig. 1). The remaining *Arabidopsis* RLKs, the receptor-like cytoplasmic kinases (RLCKs), consist of truncated variants containing a cytoplasmic kinase domain, with some of the variants also harboring a transmembrane region (Shiu and Bleecker 2001; Shiu et al. 2004; Morillo and Tax 2006). The breadth of interesting extracellular sequence motifs found among the RLKs suggests their participation in a host of plant physiological processes, ranging from pathogenesis to development (Shiu and Bleecker 2001; Morris and Walker 2003; Johnson and Ingram 2005; Morillo and Tax 2006).

### A Gene Families

The large number of plant RLKs can be classified into multiple sub-families based on the type of sequence motif found in their extracellular regions, as well as a phylogeny of their kinase

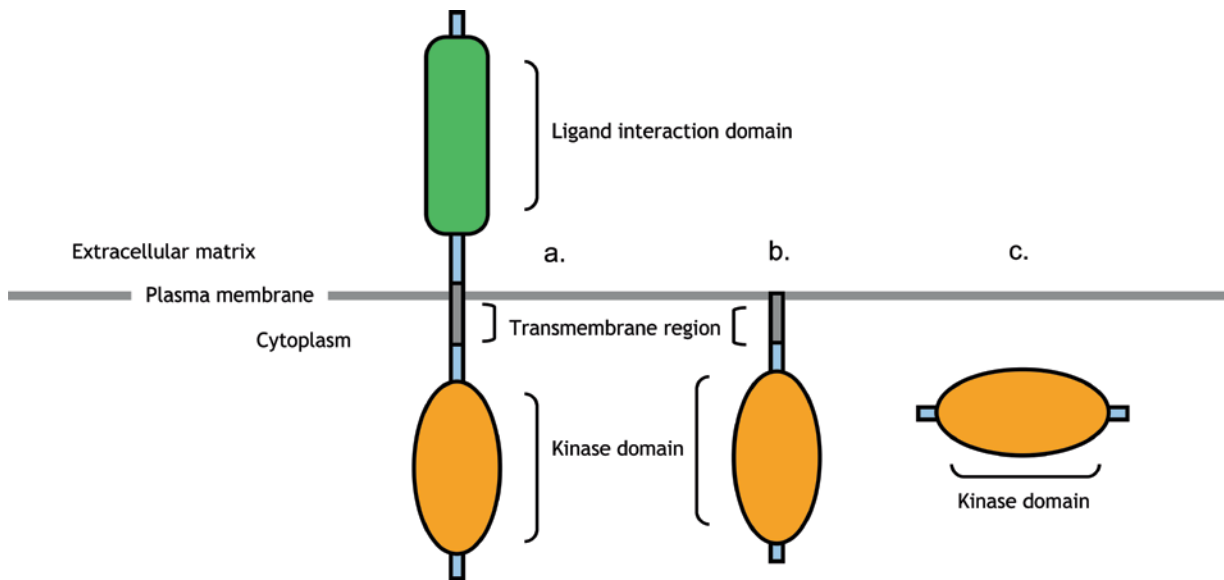

*Fig. 1.* Three major forms of receptor-like kinases. (a) The majority of identified RLKs consist of an intracellular kinase domain, a short, membrane-spanning region, and a putative extracellular domain. Several types of ligand-interaction-related motifs have been found in the sequences encoding the putative extracellular domain; (b) truncated forms of RLKs lacking extracellular regions are likely to be tethered to the cytoplasmic side of the plasma membrane by N-terminal transmembrane domains; (c) several sub-families of RLKs appear to be cytoplasmic kinases.

domains (Table 1) (Shiu and Bleecker 2001; Shiu et al. 2004). The extracellular motif present in the largest number of RLKs is the leucine-rich repeat (LRR) (Shiu and Bleecker 2001; Dievart and Clark 2004). The plant-specific LRR motif is composed of 23–25 amino acids with a conserved consensus sequence of LxxLxxLxLxxNxLt/sgx-IpxxLGx. The LRR-RLKs in *Arabidopsis* have been further classified into 14 sub-families, and the number of LRR domain found in a given member can range from two to 32 (Shiu and Bleecker 2001; Morris and Walker 2003).

While little is known about the function of LRR domains in most of the LRR-RLKs, these domains have been shown to be involved in protein–protein interactions in a number of organisms (Kobe and Deisenhofer 1995; Kobe and Kajava 2001; Kajava and Kobe 2002). Similarly, the LRR domains of plant RLKs may participate in the binding of peptide-based ligands, as seen with the CLAVATA1 (CLV1) RLK, which has been shown to interact with the receptor-like protein CLAVATA2 (CLV2) (Brand et al. 2000; Trotochaud et al. 2000). However, another set of LRR-RLKs, the BRI1-related RLKs, have been shown to bind brassinosteroid (Wang et al. 2001).

*Table 1.* The receptor-like kinases comprise a large, diverse superfamily of proteins in *Arabidopsis*.

Subfamily	Extracellular motif <sup>a</sup>	SP/TM <sup>b</sup>	Members
C-Lectin	C-Lec	1	1
CR4L	TNF	6	8
CRPK1L-1	Unknown <sup>c</sup>	15	15
CRPK1L-2	Unknown	2	2
DUF26	DUF26	40	45
Extensin	Unknown	4	5
L-Lectin	LegB, LegA	31	32
LRK10L-1	Unknown	4	5
LRK10L-2	Unknown	8	8
LRR I	LRR (2–4)	48	50
LRR II	LRR (2–4)	13	14
LRR III	LRR (4–19)	47	47
LRR V	LRR (5–6)	8	9
LRR VI	LRR (2–10)	11	11
LRR VII	LRR (7–25)	10	10
LRR VIII-1	LRR (9–11)	7	8
LRR VIII-2	LRR (8–10)	13	15
LRR IX	LRR (9–10)	4	4
LRR X	LRR (4–30)	15	16
LRR XI	LRR (4–32)	28	28
LRR XII	LRR (19–27)	10	10
LRR XIII	LRR (4–20)	6	7
LRR XIV	LRR (10–18)	3	3

(continued)

Table 1. (continued)

Subfamily	Extracellular motif <sup>a</sup>	SP/TM <sup>b</sup>	Members
LysM	LysM (1–2)	4	4
PERKL	Unknown	16	19
RKF3L	Unknown	2	2
RLCK I	NA	1	3
RLCK II	NA	0	7
RLCK III	NA	0	5
RLCK IV	NA	0	3
RLCK V	NA	11	11
RLCK VI	NA	4	14
RLCK VII	NA	2	46
RLCK VIII	NA	0	11
RLCK IX	Coil, U-Box <sup>d</sup>	1	21
RLCK X	Unknown	2	4
RLCK XI	NA	3	4
SD-1	B-Lec, EGF	31	32
SD-2	B-Lec, EGF	7	7
SD-3	B-Lec	1	1
Thaumatococcus	Thn	3	3
URK I	Unknown	2	2
WAKL	EGF (1–2)	24	25
UC <sup>e</sup>	Unknown	11	14

<sup>a</sup> Sequence motifs found in members of this subfamily, although not all members may have the motif.

<sup>b</sup> Members containing a signal peptide sequence and/or a transmembrane domain. Note that some members encode truncated proteins with only a transmembrane domain and intracellular kinase domain. Some members consist only of an intracellular domain.

<sup>c</sup> No known sequence motifs have been identified.

<sup>d</sup> U-Box motifs have been found in the intracellular, C-terminus region that trails the kinase domain.

<sup>e</sup> Sequences that do not appear to belong to any known subfamily are designated as “Unclassified”.

Source: Shiu et al. 2004.

These results are part of a growing body of experimental evidence that implicate the function of LRR-RLKs in diverse processes, ranging from hormone signaling to plant pathogen recognition to the establishment of symbiotic interactions (Morris and Walker 2003; Tichtinsky et al. 2003; Johnson and Ingram 2005; Belkhadir and Chory 2006). Some well-known examples of LRR-RLKs include brassinosteroid-insensitive1 (BRI1) (Li and Chory 1997), BRI1-associated receptor (BAK1/AtSERK3) (Li et al. 2002; Nam and Li 2002), systemin receptor160 (SR160)/CURL3 (Montoya et al. 2002; Scheer and Ryan 2002), clavata1 (CLV1) (Clark et al. 1993), flagellin-sensitive2 (FLS2) (Gomez-Gomez and Boller 2000), XA21 (Song et al. 1995), erecta

(ER) (Torii et al. 1996), INRPK1 (Bassett et al. 2000), HAESA (Jinn et al. 2000), excess microsporocytes1 (EMS1)/extra sporogenous cells (EXS) (Zhao et al. 2002), AtSERK1 (Hecht et al. 2001), hypernodulation aberrant root1 (HAR1)/soybean nodule autoregulation receptor kinase (GmNARK) (Nishimura et al. 2002; Krusell et al. 2002; Searle et al. 2003) and symbiosis receptor-like kinase (SYMRK)/nodulation receptor kinase (NORK) (Endre et al. 2002; Stracke et al. 2002).

Sugar-binding motifs are also highly prevalent among the plant RLKs. For example, the lectin motif is the second most numerous type of extracellular motif after the LRRs. Among the plant RLKs, three classes of lectin motif have been identified: the legume lectin motif, the agglutinin motif and the C-type lectin motif. Legume lectins were originally found in the seeds of leguminous plants and have been shown to bind complex sugars, including glucose-mannose, galactose-N-acetylgalactosamine, fucose and chitobiose (Sharon and Lis 1990; Herve et al. 1996; Loris et al. 1998). The agglutinin motif is known to bind  $\alpha$ -D-mannose and is found in S-domain-containing RLKs such as SRK (Stein et al. 1991; Hester et al. 1995; Schopfer et al. 1999). Proteins containing C-type lectin motifs are known to bind sugar moieties found on the surfaces of non-self cells (Epstein et al. 1996; Weis and Drickamer 1996; Hawgood and Poulain 2001). However, the specific binding properties of the agglutinin and C-type lectin motifs found in plant RLKs have yet to be fully characterized.

Plant RLKs also contain several other types of sugar-binding motifs. For example, the LysM subfamily of RLKs in *Arabidopsis* contains a lysin motif. From studies of other proteins, the lysin motif has been shown to bind peptidoglycans, such as those found in bacterial cell walls, suggesting the possibility that the lysin motifs in plant RLKs may be involved in bacterial pathogen defense (Bateman and Bycroft 2000). The extracellular domain of tobacco chitinase receptor kinase1 (CHRK1) contains a chitin-binding motif. However, amino acid sequence analysis of CHRK1 reveals the absence of a glutamic acid residue needed for chitinase function and experiments with CHRK1 have yet to reveal any chitin-related biochemical activity (Kim et al. 2000b). Finally, thaumatococcus domains, such as those involved in antifungal and chitinase processes, have been

found in the thaumatin sub-family of *Arabidopsis* RLKs (Wang et al. 1996; Pan et al. 1999).

Other notable extracellular motifs include the pectin-binding motif, epidermal growth factor (EGF) repeats, and the tumor necrosis factor receptor (TNFR) motif. Pectin-binding motifs have been found in the extracellular domains of cell wall-associated kinase (WAK)-type RLKs, which may allow them to bind the pectin found in the middle lamella and primary cell wall (Wagner and Kohorn 2001). EGF repeats, which are also found in animal RTKs, are present in WAK-type and SRK-type RLKs (He et al. 1999b; Handford et al. 1995). The TNFR motif, which is known to be involved in programmed cell death (PCD) in animals, is found in the CRINKLY4-type RLKs (Becraft et al. 1996; Naismith and Sprang 1998).

In contrast to the extracellular domain, the intracellular serine/threonine kinase domains of the plant RLKs are highly conserved with 11 known sub-domains (Walker 1994). Flanking the conserved kinase domain are a juxtamembrane domain and a C-terminal tail domain, both of which display diverse sequence composition among the RLKs. For several RLKs, it has been shown that phosphorylation of the kinase catalytic domain leads to enzymatic activation and receptor kinase activity (Johnson et al. 1996; Huse and Kuriyan 2002). However, phosphorylation of the flanking domains is also a known phenomenon. For example, BRI1 can autophosphorylate at least 12 cytoplasmic residues, five of which are located in the juxtamembrane domain and at least two are found in the C-terminal tail (He et al. 2000; Oh et al. 2000). One explanation for this result is that phosphorylation of the non-catalytic flanking domains may be necessary for RLK autoregulation or to provide phosphorylated residues for the docking of downstream cytoplasmic targets (Pawson 2002).

## B Functions

### 1 Disease Resistance

Plant disease resistance is a complex response that involves two main events. The first event is the recognition of signals from the pathogen. The second event is the activation of defense-related processes, including production of reactive oxygen species (ROS), modifications of the cell

wall, the hypersensitive response (HR) and the synthesis of pathogen-related (PR) proteins and phytoalexins (Yang et al. 1997). Several studies have shown that specific RLKs play an important role in defense-related signal transduction, including Xa21 from rice, LRK10 from wheat and FLS2 and PBS1 from *Arabidopsis*, among others (Morillo and Tax 2006; Nürnberger and Kemmerling 2006).

The rice Xa21 gene is an LRR XII RLK that confers gene-for-gene resistance to specific races of the causal agent of bacterial blight disease, *Xanthomonas oryzae* pv. *oryzae* (Song et al. 1995; Wang et al. 1996; Lee et al. 2006). The discovery of an E3 ubiquitin ligase known as XB3 (XA21-binding protein 3) has shed more light on the role of Xa21 in disease resistance (Wang et al. 2006). XB3 acts as a substrate for the Xa21 kinase domain and contains an ankyrin repeat domain and a RING finger motif. The ankyrin repeat domain appears to be required for the interaction of XB3 with the kinase domain of Xa21, while the RING finger motif is essential for the E3 ubiquitin ligase activity of XB3. Furthermore, transgenic plants with reduced expression of the XB3 gene are compromised in resistance to the avirulent race of *Xanthomonas oryzae* pv. *oryzae* (Wang et al. 2006).

In addition to Xa21, a number of other RLKs appear to provide the ability to detect specific pathogenic signals. For example, the LRR-RLK EF-Tu (EFR) has been identified as a receptor for the bacterial protein EF-Tu, a known elicitor of innate immunity responses in *Arabidopsis* (Zipfel et al. 2006). The LRR-RLK flagellin sensitive 2 (FLS2) has been shown to be involved in the recognition of flagellin, another known bacterial elicitor of plant defense responses (Fig. 2) (Gomez-Gomez and Boller 2000; Gomez-Gomez et al. 2001).

In the case of FLS2, mutations in both the LRR and the kinase domains affected the binding activity to the flagellin peptide flg22 (Gomez-Gomez et al. 2001; Chinchilla et al. 2006). It appears that FLS2-mediated responses may involve a mitogen-activated protein kinase (MAPK) cascade. Asai et al. (2002) showed that FLS2 could both directly and indirectly activate a MAPK cascade involving MEKK1, MKK4/MKK5, and MPK3/MPK6. The activation of the pathway led to the induction of a number of defense genes,



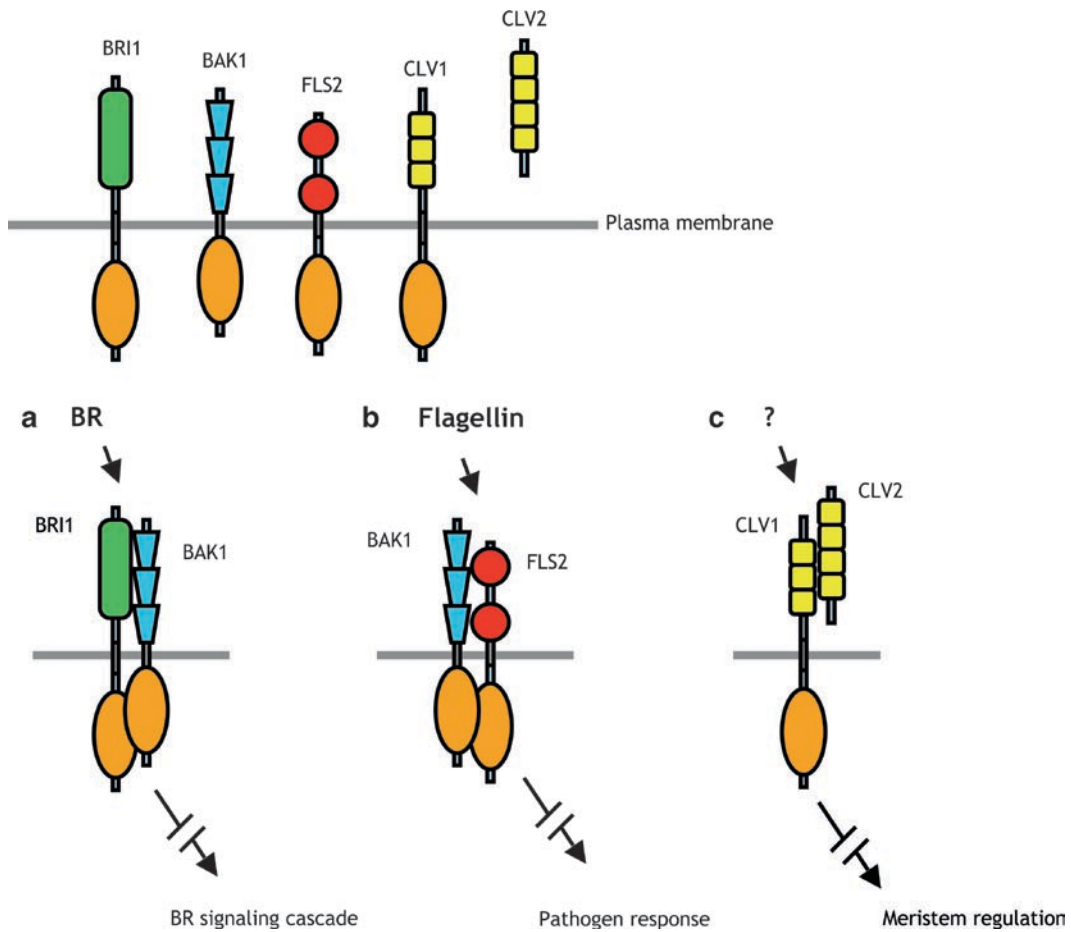

Fig. 2. Examples of RLK activation. RLKs are thought to exist in monomeric state and in the presence of the appropriate ligand, the RLK monomers may homo- or hetero-dimerize to initiate a signaling cascade. (a) The BRI1 RLK interacts with the BAK1 RLK to transduce the signal from the plant steroid known as brassinosteroid; (b) flagellin can act as a signal for a pathogen defense-related pathway involving the RLKs BAK1 and FLS2; (c) CLV1, an RLK, interacts with the receptor-like protein CLV2 during processes involved in meristem regulation.

including PAL1, GST1, PR1, and PR5, as well as the transcription factors WRKY22/WRKY29 and another LRR-RLK receptor, FRK1 (FLG22-induced receptor-like kinase 1). Furthermore, the kinase domain of FLS2 interacts with the *Arabidopsis* kinase-associated protein phosphatase known as KAPP. Over-expression of KAPP led to flagellin-insensitivity in transgenic plants, suggesting that KAPP is a negative regulator of the FLS2 signaling pathway (Gomez-Gomez et al. 1999).

In tomato, the LRR RLKs Pto, Pti and PBS are involved in mediating the defense response to bacterial pathogens (Martin et al. 1993; Zhou et al. 1995, 1997; Swiderski and Innes 2001).

Pto directly interacts with avrPto, a small peptide secreted by the pathogen *Pseudomonas syringae* pv. tomato, thereby triggering defense resistance (Martin et al. 1993; Scofield et al. 1996; Tang et al. 1996). Pti1, Pti4, Pti5, and Pti6 were identified to interact specifically with Pto through yeast two-hybrid screens and are capable of conferring disease resistance (Zhou et al. 1995, 1997). Pti1 is a serine-threonine kinase that is phosphorylated by Pto and is required for the avrPto-Pto mediated hypersensitive response (Zhou et al. 1995). Pti4-6 encodes ethylene responsive element binding proteins (EREBPs) and binds to the promoter regions of genes encoding a large number of pathogenesis-related proteins (Zhou et al. 1997).

In addition to bacterial pathogens, RLKs have been shown to be important in recognizing and responding to fungal pathogens. For example, LRK10 in wheat has been implicated in mediating wheat rust fungal resistance (Feuillet et al. 1997). The rice B-lectin receptor kinase (Pi-d2), which represents a new class of plant resistance gene, confers race-specific resistance to the rice blast fungal pathogen *Magnaporthe grisea* (Chen et al. 2006). It was also reported that an RLK gene in barley, Rpg1, confers resistance to the barley stem rust fungus *Puccinia graminis* sp. *tritici* (Nirmala et al. 2006). Transgenic barley expressing a version of Rpg1 that had a mutated kinase domain was fully susceptible to *Puccinia graminis* sp. *tritici* (Nirmala et al. 2006). Finally, research into the WAK-like RLKs has revealed that several members of this subfamily may be involved in defense responses (He et al. 1996, 1998). For example, a WAK1 antisense line showed increased sensitivity to the salicylic acid analog 2,2-dichloro-isonicotinic acid (INA), suggesting that WAK1 is involved in disease resistance in *Arabidopsis* (He et al. 1998).

## 2 Hormone Signaling

Brassinosteroids (BR) are a class of plant steroid hormone involved in many signaling events related to plant growth, development and environmental responses (Clouse and Sasse 1998; Belkhadir and Chory 2006; Haubrick and Assmann 2006). The *Arabidopsis* BRI1 gene, an LRR X RLK, was identified to encode a transmembrane BR receptor using a genetic screen for BR sensitivity (Clouse et al. 1996; Li and Chory 1997; Wang et al. 2001). Phenotypes for *bri1* mutants include dwarfed height, male sterility, and de-etiolation in the dark (Clouse et al. 1996). BAK1 (also known as AtSERK3), an LRR II RLK, is a genetic and physical interactor with BRI1 (Fig. 2) (Li et al. 2002; Nam and Li 2002). Experimental results suggest that BRI1 phosphorylates BAK1 upon BR binding (Wang et al. 2005). The BRI1-like RLKs BRL1 and BRL3 are so named because of the similarity of their protein sequences to that of BRI1. Each has been shown to be capable of binding BR. In addition, expression of BRL1 and BRL3 using a constitutive promoter or the promoter from BRI1 results in the rescue of weak *bri1* mutant phenotypes. Both BRL1 and BRL3

appear to localize to the plasma membrane and have a role in vascular differentiation (Cano-Delgado et al. 2004; Zhou et al. 2004).

Orthologs of BRI1 have been found in a number of plant species, including tomato (Curl3/SR160/tBRI1), pea (LKA/PsBRI1), cotton (GhBRI1), grape (VvBRI1), rice (OsBRI1) and barley (HvBRI1) (Yamamuro et al. 2000; Montoya et al. 2002; Chono et al. 2003; Nomura et al. 2003; Sun et al. 2004; Nakamura et al. 2006; Symons et al. 2006). Mutations in the barley and rice BRI1 orthologs give classic *bri1* mutant phenotypes, such as dwarfism, BR insensitivity and BR accumulation (Yamamuro et al. 2000; Chono et al. 2003; Nakamura et al. 2006). Interestingly, it has been discovered that the tomato BRI1 homolog, Curl3/SR160/tBRI1, acts as the receptor for systemin, an 18–22 amino acid signaling peptide involved in plant wounding responses and other defense mechanisms (Montoya et al. 2002; Narvaez-Vasquez and Ryan 2002; Scheer and Ryan 2002). Orthologs of the BRI1-like genes have been studied in rice (OsBRL1, OsBRL2, and OsBRL3), with OsBRL1 and OsBRL3 displaying a root-specific expression pattern not observed in *Arabidopsis* (Cano-Delgado et al. 2004; Nakamura et al. 2006).

More recent results provide an emerging picture of BRI1-mediated BR signaling in plants. For example, the genes BRI1-EMS-suppressor 1 (BES1) and brassinazole resistant 1 (BRZ1) appear to act downstream of the BRI1 receptor. BES1 and BRZ1 gene products have N-terminal nuclear localization signals and positively regulate BR signaling (He et al. 2002; Wang et al. 2002; Yin et al. 2002; Vert and Chory 2006). Gain-of-function *bes1-D* mutants display constitutive BR response phenotypes, including the extensive elongation of leaves and stems under light conditions. However, gain-of-function *brz1-D* mutants exhibit a semi-dwarf phenotype due to inhibition of the normal BR signaling pathway (Wang et al. 2002; Yin et al. 2002).

Several studies have reported that brassinosteroid-insensitive2 (BIN2), which encodes a GSK3/Shaggy-like protein kinase, is an upstream repressor of BES1 and BRZ1 (He et al. 2002; Wang et al. 2002; Yin et al. 2002). Gain-of-function *bin2* mutants have a BR-deficient phenotype suppressed by *bes1-D*, indicating that BIN2 may act upstream of BES1 (Yin et al. 2002). Furthermore, both BRZ1 and BES1 contain multiple consensus

phosphorylation sequences (S/TxxxS/T) known to be phosphorylated by GSK3/SHAGGY kinases. BIN2 also directly interacts with BES1 and BRZ1, phosphorylating both proteins *in vitro*. In the absence of BR, constitutively activated BIN2 phosphorylates BES1 and BRZ1, which leads to their degradation. In the presence of BR, activation of the BRI1 complex at the plasma membrane leads to the inhibition of BIN2 kinase activity (Wang et al. 2002; Yin et al. 2002).

### 3 Plant Development

RLKs have been shown to have roles in number of plant developmental processes, including symbiont recognition, cell differentiation, and the regulation of cell division and expansion. For example, an important symbiotic interaction in root nodule development is the infection of legumes by rhizobia. Some LRR-RLK families, including alfalfa nodulation receptor kinase (NORK) (Endre et al. 2002) and symbiosis receptor-like kinase (SYMRK) (Stracke et al. 2002), were shown to be receptors involved in the establishment of rhizobial symbiosis. In addition to these RLKs, LysM motif-containing RLKs are also shown to be required for recognition of rhizobial signals in lotus (Madsen et al. 2003; Radutoiu et al. 2003). The LysM motif is also found in bacterial peptidoglycan-binding proteins and chitinases.

Several RLKs have been identified to regulate growth processes in plant development. The aforementioned BRI1 RLK, the receptor for brassinosteroids in *Arabidopsis*, is an important factor in plant photomorphogenesis (Li and Chory 1997). The carrot RLK known as PSKR binds pentapeptide phyto-sulfokine, which has a demonstrated role in cell de-differentiation and proliferation (Matsubayashi et al. 2002). The RPK1 gene in *Arabidopsis* has been shown to be transcriptionally induced by abscisic acid (ABA), and *rpkl* mutants display an ABA-insensitive phenotype (Osakabe et al. 2005). The EXS/EMS1 gene, an LRR X RLK, is required for the development of the tapetal cell layer, one of the four layers of support cells required for pollen development (Canales et al. 2002; Zhao et al. 2002). Mutations in EXS/EMS1 result in male sterility and a lack of cell expansion in embryos (Canales et al. 2002). Another *Arabidopsis* RLK, SCM/SUB, is necessary for cell patterning during the formation of root hairs in the root epidermis (Kwak et al. 2005).

Several members of the cell wall-associated kinase (WAK) sub-family have been demonstrated to be involved in cell expansion, while many of the WAK genes appear to be induced by pathogens, wounding and other stresses (Anderson et al. 2001; Zhang et al. 2005a; Kohorn et al. 2006). Experiments with the WAK2 gene indicate that this *Arabidopsis* RLK may provide an important link between solute metabolism, turgor pressure and cell expansion. T-DNA-based *wak2* mutants display a growth arrest phenotype that can be suppressed by the expression of a constitutive form of sucrose phosphate synthase. This suppression is also correlated with reduced levels of vacuolar invertase. It is hypothesized that WAK2 may regulate solute metabolism in a way that affects cell turgor and consequently, cell expansion (Kohorn et al. 2006). The WAK-like gene WAKL4 also has a cell expansion-related mutant phenotype. Additionally, Hou et al. (2005) reported that WAKL4 is involved in mineral responses in *Arabidopsis*. The WAKL4 RLK appears to be required for the up-regulation of zinc transporter genes during zinc deficiency and WAKL4 T-DNA insertion lines display a reduction of zinc accumulation in shoots.

Clavata1 (CLV1) is an LRR XI RLK in *Arabidopsis* that regulates organ formation at shoot and flower meristems by promoting the differentiation of stem cells on the meristem flanks (Fig. 2) (Clark et al. 1997). It was also reported that the barley meristem 1–3 (BAM1-3) genes, which are closely related to CLV1, are required for meristem function in *Arabidopsis* (DeYoung et al. 2006). The BAM genes are expressed in apical meristems and are positive regulators of meristem size (DeYoung et al. 2006). Several studies were performed to determine the downstream components of CLV1, revealing that CLV1 may be associated in a complex with Rop, a plant-specific small Rho-related GTPases (Trotochaud et al. 1999).

Two different type-2C protein phosphatases (PP2C), including the kinase associated protein phosphatase (KAPP) and the protein phosphatase poltergeist (POL), negatively regulate the CLV1 pathway (Williams et al. 1997; Stone et al. 1998; Yu et al. 2000, 2003). Over-expression of KAPP, which can bind the kinase domain of several RLKs with forkhead-associated domain (FHA) depending on phosphorylation status, resulted in a *clv1*-like mutant phenotype (Williams et al.

1997; Stone et al. 1998; Shah et al. 2002). In contrast, suppression of KAPP expression reduced the severity of the *clv1* mutation, indicating that KAPP acts as a negative regulator of the CLV1 pathway (Williams et al. 1997; Stone et al. 1998). POL, which is predicted to be nuclear-localized, was also shown to regulate the CLV1 pathway by affecting the activity of WUS, a target protein of the CLV1 pathway (Yu et al. 2000, 2003).

### III Mitogen Activated Protein (MAP) Kinases and MAPK Cascades

Mitogen-activated protein kinases (MAPKs) are serine/threonine-specific kinases that provide fundamental signaling capacity in many signal transduction pathways involved in cell growth, differentiation, and stress response (Lewis et al. 1998; Chang and Karin 2001; Tena et al. 2001). Signaling cascades composed of different types of MAPKs can be found throughout the eukaryotic domain, including animals, yeasts and plants (Herskowitz 1995; Tena et al. 2001; Hamel et al. 2006). These so-called MAPK cascades link upstream receptors to downstream targets via interactions involving MAPKs, MAPK kinases (MAPKKs) and MAPKK kinases (MAPKKKs).

In a typical MAPK cascade, MAPKKs activate MAPKs via dual phosphorylation of conserved threonine and tyrosine residues in the TxY motif, which is located in the activation loop (T-loop) between kinase subdomains VII and VIII. MAPKKs are themselves activated by MAPKKKs through phosphorylation of conserved serine/threonine residues in the S/T-X3-5-S/T motif, also located in the T-loop (Jonak et al. 2002). Generally, MAPKKKs are activated by physically interacting with a receptor and becoming phosphorylated either by the receptor itself or an interlinking upstream protein kinase (Chang and Karin 2001).

In plants, MAPK cascades are associated with various physiological, developmental and hormonal responses. For example, studies have revealed that MAPK cascades are activated by many types of treatments, including pathogen infection, wounding, low temperature, drought, hyper- and hypo-osmolarity, high salinity, touch and reactive oxygen species (Morris 2001; Romeis 2001; Tena et al. 2001; Zhang and Klessig 2001; Chang 2003; Nakagami et al. 2005; Mishra et al.

2006; Zhang et al. 2006). Such cascades have been found in large number throughout a variety of plant species, including *Arabidopsis*, tobacco, *Medicago* and rice (MAPK group 2002; Agrawal et al. 2003; Hamel et al. 2006). In the *Arabidopsis* genome alone, genes encoding 20 MAPKs, 10 MAPKKs and 80 MAPKKKs have been identified (MAPK group 2002; Nakagami et al. 2005; Hamel et al. 2006).

#### A Gene Families

##### 1 MAPKs

To date, all identified plant MAPKs appear to belong to the ERK (extracellular signal-regulated Kinase) sub-family of MAPKs, as no plant representatives of the p38 or JNK (c-Jun N-terminal kinase) sub-families have been found (Jonak et al. 1994). Among the plant MAPKs, the amino acid sequences of the 11 sub-domains comprising the serine/threonine kinase domain are highly conserved (Hanks et al. 1998). However, some plant MAPKs have additional N-terminal and C-terminal domains, which appear to have greater sequence divergence than the kinase catalytic core. Based on their overall deduced amino acid sequences, plant MAPKs can be divided into four sub-families (I–IV) (MAPK group 2002; Agrawal et al. 2003; Hamel et al. 2006).

Group I MAPKs appear to be involved in a variety of environmental and hormonal responses. For example, AtMPK3 and AtMPK6 in *Arabidopsis* are activated by environmental stresses such as pathogen infection, osmotic stress and oxidative stress (Mizoguchi et al. 1996; Ichimura et al. 2000; Kovtun et al. 2000; Nuhse et al. 2000; Desikan et al. 2001; Yuasa et al. 2001; Asai et al. 2002). Similarly, experimental results strongly indicate that tobacco SIPK, which is salicylic acid (SA)-inducible, and alfalfa SIMK and SAMK are involved in both biotic and abiotic stress responses (Munnik et al. 1999; Zhang and Klessig 2001; Zwerger and Hirt 2001). Tobacco WIPK, which shares high sequence similarity with AtMPK3, has been demonstrated to be involved in wound-signal transduction and may directly phosphorylate NtWIF, a transcription factor that activates expression of a number of wound and pathogen response genes (Seo et al. 1995; Yap et al. 2005). Finally, bacterial and fungal pathogens appear to



activate a MEKK1-MKK4/MKK5-MPK3/MPK6 signaling cascade that links the flagellin receptor FLS2 to the transcription factors WRKY22 and WRKY29 in *Arabidopsis* (Asai et al. 2002).

Group II MAPKs are less well-studied than the group I MAPKs, but appear to be involved in both environmental stress responses as well as cell division. For example, the *Arabidopsis mpk4* mutant displays a constitutive systemic-acquired-resistance phenotype (Petersen et al. 2000). Furthermore, MPK4 protein is activated under both biotic- and abiotic-stress related treatments, including low temperature, hyper-osmolarity and wounding (Desikan et al. 2001; Ichimura et al. 2000). In terms of cell division, alfalfa MMK3 and tobacco Ntf6 have been shown to be activated in a cell-cycle-dependent manner and specifically localized in the phragmoplast during telophase (Calderini et al. 1998; Bogre et al. 1999).

Very little is known about the group III MAPKs, which like the group I and II MAPKs, contain a TEY motif in their T-loop. Studies of the group III MAPK known as MPK7 have shown it to be regulated in a circadian-rhythm-dependent manner in *Arabidopsis* (Schaffer et al. 2001).

Group IV MAPKs differ from group's I-III in that they have a TDY motif instead of TEY motif in their T-loop, as well as an extended C-terminal region. Examples of group IV MAPKs include *Arabidopsis* AtMPK8, AtMPK9 and AtMPK15, BWMK1 from rice and TDY1 from alfalfa. Among these, experimental results indicate that BWMK1 and TDY1 are inducible by blast fungus and wounding, respectively (He et al. 1999a; Schoenbeck et al. 1999; Cheong et al. 2003b). In particular, BWMK1 can directly phosphorylate the transcription factor OsEREBP1 (ethylene-responsive element binding protein 1). Once phosphorylated, OsEREBP1 can enhance the binding of a factor to the GCC box element, which is found in the promoters of several fundamental PR genes (Cheong et al. 2003b).

## 2 MAPKKs

Twenty-one MAPKK genes have been identified in plants, including *Arabidopsis* MKK1 (renamed from MEK1) and MKK2-5, alfalfa SIMKK and PRKK, tobacco NtMEK1-2 and SIPKK, tomato LeMEK1, and maize ZmMEK1 (MAPK group 2002; Hamel et al. 2006). Plant MAPKKs have a

phosphorylation site containing the motif S/T-X5-S/T, which differs from their mammalian counterparts. In addition, plant MAPKKs contains a putative N-terminal MAPK-docking domain that is characterized by a cluster of basic and hydrophobic residues (K/R-K/R-K/R-X1-6-LX-L/V/I).

The *Arabidopsis* genome encodes ten MAPKK genes that can be classified into four different groups (A-D) (MAPK group 2002). The group A MAPKKs, MKK1 and MKK2, are thought to be upstream factors for MPK4, based on in vitro kinase assays, yeast two-hybrid analysis and complementation of yeast MAPK cascade mutants (Ichimura et al. 1998; Mizoguchi et al. 1998; Huang et al. 2000; Matsuoka et al. 2002; Meszaros et al. 2006). Analysis of MKK1 using a specific antibody revealed that it can be activated by multiple abiotic stresses (Matsuoka et al. 2002).

*Arabidopsis* MKK2 acts as an upstream activator of MPK6 in addition to MPK4, and appears to mediate cold and salt stress signaling (Teige et al. 2004). MKK2 has been shown to be activated by the stress-inducible MAPK Kinase Kinase known as MEKK1. Plants over-expressing MKK2 exhibited constitutive MPK4 and MPK6 activity, constitutively upregulated expression of stress-induced marker genes, and increased freezing and salt tolerance. In contrast, *mkk2* null mutant plants were impaired in MPK4 and MPK6 activation and were hypersensitive to salt and cold stress (Teige et al. 2004).

Functional evidence has been produced for two other group A MAPKKs, alfalfa PRKK and tobacco NtMEK1. PRKK (pathogen-responsive MAPKK) was shown to transmit pathogen-elicited signals to downstream MAPKs (Cardinale et al. 2002). NtMEK1, which is similar to *Arabidopsis* MKK6, is involved in cell division and in the activation of the tobacco MAPK, known as Ntf6 (Calderini et al. 2001).

The group B MAPKKs, which include *Arabidopsis* MKK3 and tobacco NPK2, have an unusual structural feature consisting of a nuclear transport factor 2 (NTF2) domain in their extended C-terminus region (Quimby et al. 2000). The group C MAPKK, alfalfa SIMKK, has been shown to activate SIMK and mediate both salt and elicitor-induced signals with different substrate specificities (Kiegerl et al. 2000; Cardinale et al. 2002). Transient overproduction of a constitutively active form of tobacco NtMEK2,

another group C MAPKK, caused not only activation of the MAPKs SIPK and WIPK, but also hypersensitive cell death in leaves (Yang et al. 2001). Moreover, stable transformation with *Arabidopsis* MKK4 and MKK5, putative orthologs of tobacco NtMEK2, showed similar effects (Ren et al. 2002). There is no information on the function and production of Group D MAPKKs.

### 3 MAPKKKs

The MAPKKK family forms the largest group of MAPK pathway components found in plants. For example, the *Arabidopsis* genome encodes 80 putative MAPKKK genes. Plant MAPKKKs can be divided into two subfamilies: (1) the MEKK-like protein kinases that are most similar to animal MEKKs, and (2) Raf-like protein kinases (MAPK group 2002). Some prominent examples of MEKK-like protein kinases include OMTK1 (oxidative stress-activated MAP triplekinase 1 from alfalfa; ANP1-3, YDA and AtMEKK1 from *Arabidopsis*, and NPK1 from tobacco (Mizoguchi et al. 1996; Kovtun et al. 2000; Nishihama et al. 2001; Lukowitz et al. 2004; Nakagami et al. 2004). Members of the plant Raf-like protein kinases include EDR1 (enhanced disease resistance 1) and CTR1 (constitutive triple response 1) from *Arabidopsis* (Frye et al. 2001; Kieber et al. 1993).

In terms of functionality, the expression of AtMEKK1 is activated by drought, high salinity and touch (Mizoguchi et al. 1996). Further functional analyses suggest that AtMEKK1 acts as an upstream activator of MKK1, MKK2, MKK4 and MKK5 during pathogen defense and under abiotic stress conditions (Ichimura et al. 1998; Mizoguchi et al. 1998; Asai et al. 2002; Teige et al. 2004).

Tobacco NPK1, an ortholog of ANP1-3, has been shown to be involved in cytokinesis (Nishihama et al. 2001). NPK1 interacts and localizes with its activators NACK1 and NACK2 (both kinesin-like proteins), during M phase, which is required for the intracellular events that lead to cytokinesis (Nishihama et al. 2002). Moreover, a reverse-genetic approach using multiple-knockout mutants of the ANP genes revealed their function as a positive regulator of cytokinesis and a possible negative regulator for stress responses (Krysan et al. 2002). ANPs and NPK1 also function in oxidative-stress-response

signaling and as negative regulators of the auxin-response pathway (Kovtun et al. 1998, 2000). In contrast, *Medicago* OMTK1 was shown to serve as scaffold proteins, assembling specific MAPK pathway components into particular modules (Nakagami et al. 2004).

As for the Raf-like MAPKKKs, EDR1 functions as a negative regulator in pathogen resistance. Mutant *edr1* lines confer resistance to *Erysiphe cichoracearum*, a fungus that causes powdery mildew disease (Frye et al. 2001). Furthermore, kinase-deficient EDR1 over-expression enhances resistance to powdery mildew, indicating that EDR1 is a negative regulator of defense (Tang and Innes 2002). The CTR1 Raf-like MAPKKK acts as a negative regulator in ethylene signaling (Kieber et al. 1993). Mutant *ctr1* plants display a constitutive triple response in the absence of ethylene. It has been hypothesized that in the absence of ethylene, the ethylene receptors ETR1 and ETR2 constitutively activate CTR1 (Kieber et al. 1993).

## B Functions

### 1 Disease Resistance

As noted, a number of plant MAPK-related genes appear to be involved in the defense response against pathogens. Current research has started to establish a more detailed picture of how these elements act together in coordinating such responses (Nakagami et al. 2005; Asai et al. 2002). In *Arabidopsis*, MPK3, MPK4 and MPK6 are all activated by bacterial and fungal PAMPs (pathogen-associated molecular patterns) (Nuhse et al. 2000; Desikan et al. 2001). Additionally, it was discovered that the MEKK1–MKK4/MKK5–MPK3/MPK6 module is a critical signaling pathway linking the flagellin receptor FLS2 to the activation of the WRKY22 and WRKY29 genes (Fig. 3). Furthermore, transient overexpression of the kinase domain from MEKK1 resulted in resistance to bacterial and fungal pathogens in leaves. Similar results were obtained in lines with constitutively active forms of MKK4, MKK5, and WRKY29 (Asai et al. 2002). The MPK6 MAPK appears to be involved specifically in fungal defense, as MPK6-silenced *Arabidopsis* plants displayed resistance to avirulent *Peronospora parasitica* strains and

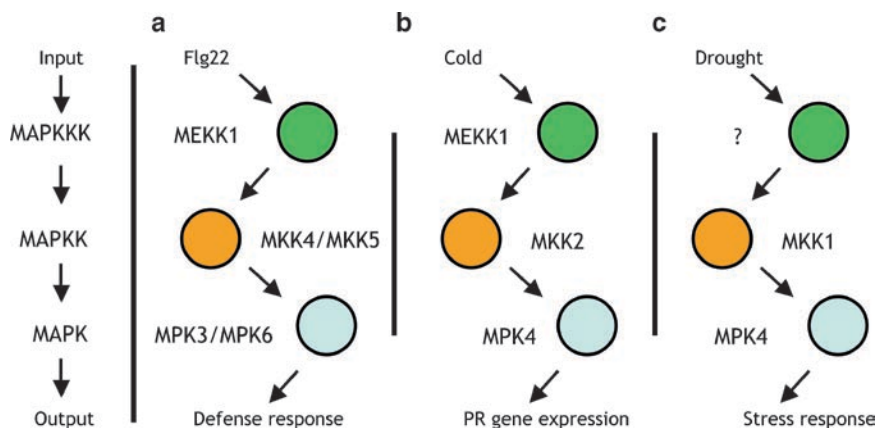

Fig. 3. Mitogen Activated Protein Kinase (MAPK) signaling cascades play pivotal intermediary roles in many plant responses to environmental stress. (a) The MEKK1-MKK4/MKK5-MPK3/MPK6 pathway is known to be involved in transducing the pathogen-related signal initiated by the flagellin peptide, flg22; (b) MEKK1 is also involved in the cold-activated expression of pathogen-resistance genes, through the MEKK1-MKK2-MPK4 pathway; (c) during the response to drought, a MAPK cascade involving MKK1 and MPK4 is constructed, although the identity of the upstream MAPKKK remains unknown [See Color Plate 3, Fig. 5].

both avirulent and virulent *Pseudomonas syringae* strains (Menke et al. 2004).

AtMPK4 appears to function as a pivotal regulator of pathogen defense responses. Experimental evidence has shown MPK4 to negatively regulate the accumulation of salicylic acid (SA) during pathogenesis, but positively regulate the signaling pathway involving jasmonic acid (JA) (Petersen et al. 2000). Mutant *mpk4* plants exhibit increased resistance to virulent pathogens with downstream effects that include elevated salicylic acid levels, the activation of systemic acquired resistance, and constitutive expression of pathogenesis-related genes. MPK4 was also shown to be required for jasmonic acid-mediated gene expression, as the induction of the jasmonic acid-response genes PDF1.2 and THI2.1 was not significantly changed after treatment with methyl jasmonate in *mpk4* mutants (Petersen et al. 2000).

Furthermore, it was recently reported that MP4K regulates SA-dependent and JA/ethylene (ET)-dependent responses via EDS1 and PAD4 (Brodersen et al. 2006). Plant *mpk4* mutants were shown to be defective in defense gene induction in response to ethylene, as well as being more susceptible to *Alternaria brassicicola*, which induces JA/ET defense pathways. Mutations in the defense regulators EDS1 and PAD4 abolish the de-repression of the SA pathway and suppress the inhibition of the JA/ET pathway in *mpk4* mutants. Results indicate that MPK4 negatively

regulates both EDS1 and PAD4 (Brodersen et al. 2006). A downstream substrate of MPK4 has also been identified. MKS1 (MAP kinase substrate 1) was shown to couple MPK4 to the WRKY transcription factors WRKY25 and WRKY33. Overexpression of MKS1 in wild-type plants enhanced the activation of SA-dependent resistance, but did not seem to affect the induction of JA-related defense genes (Andreasson et al. 2005).

Analysis of plants carrying T-DNA knockout alleles indicated that MEKK1 is required for flg22-induced activation of MPK4 but not MPK3 or MPK6 (Meszaros et al. 2006; Suarez-Rodriguez et al. 2007). Interestingly, kinase-impaired version of MEKK1 showed that the kinase activity of MEKK1 may not be required for flg-22-induced MPK4 activation or for other macroscopic FLS2-mediated responses. Mutant *mekk1* lines display a severe dwarf phenotype, constitutive callose deposition and constitutive expression of pathogen response genes, indicating MEKK1 acts upstream of MPK4 as a negative regulator of pathogen-response pathways (Suarez-Rodriguez et al. 2007).

In tobacco, the MAPKs SIPK and WIPK are activated in an N resistance gene-mediated manner upon infection with TMV (tobacco mosaic virus), resulting in HR-like cell death (Zhang and Klessig; 1998, Zhang et al. 2000; Zhang and Liu 2001). Transient expression of SIPK was shown to be sufficient to activate defense gene expression

and to induce HR-like cell death upon activation by its upstream kinase, NtMEK2 (Yang et al. 2001). The NtMEK2–SIPK/WIPK pathway also plays an upstream role in N gene-mediated resistance (Lee et al. 2001; Jin et al. 2003). The increase of SIPK and WIPK activity induced the expression of 3-hydroxy-3-methyl-glutaryl CoA reductase (HMGR), a gene encoding a key enzyme in the phytoalexin biosynthesis pathway (Zhang and Liu 2001). WIPK accumulation and activity were also induced by wounding of tobacco leaves (Seo et al. 1999).

Additionally, Kim and Zhang (2004) reported that the NtMEK2-SIPK/WIPK cascade in tobacco can activate members of the WRKY family of transcription factors, which transcribe a number of disease resistance genes. In tobacco leaves producing constitutively active NtMEK2 protein, the Spm-induced HR marker genes were found to be upregulated (Takahashi et al. 2004). Moreover, it was shown that SIPK can phosphorylate and activate WRKY1 and co-expression of WRKY1 and SIPK showed more rapid cell death than overexpression of either alone (Menke et al. 2005). Furthermore, WIPK may directly phosphorylate a transcription factor, NtWIF, which is involved in the transcription of wound and pathogen response genes (Yap et al. 2005). These results suggest that the NtMEK2-SIPK/WIPK module is specifically involved in pathogen defense in tobacco and controls multiple defense responses to pathogen invasion. Finally, virus-induced gene silencing of MEK1 and NTF6 decreased N-mediated resistance of tobacco to TMV, perhaps by affecting the activity of downstream transcription factors WRKY and MYB (Liu et al. 2003).

In *Nicotiana benthamiana*, a constitutively active form of potato StMEK1 induces the activity of SIPK and WIPK, enhances HR-like cell death, and induces the expression of a ROS-related gene known as respiratory burst oxidase homolog (RBOH) (Yoshioka et al. 2003; Katou et al. 2005). Additionally, transgenic StMEK1 potato plants were resistant to the early blight pathogen *Alternaria solani*, as well as *Phytophthora infestans*, resulting in the induction of defense-related gene expression in transgenic potato leaves (Yamamizo et al. 2006). Furthermore, StMEK1 activated StMPK1, a potato ortholog of SIPK in vitro. Virus-induced gene silencing of NbPPS3, a protein phosphorylated by StMPK1,

significantly delayed StMEK1-induced cell death, suggesting that NbPPS3 is a physiological substrate of StMPK1 and is involved in the StMPK1-mediated signaling pathway leading to HR cell death (Katou et al. 2005).

Many MAPK pathway components also have been identified and studied in rice (Agrawal et al. 2003). Rice OsMAPK5 (alternatively called MSRMPK2, MAPK2, MAP1 or BIMK1), an ortholog of MPK3 in *Arabidopsis*, was activated by several biotic and abiotic stresses, as well as by abscisic acid (Xiong and Yang 2003). RNA-interference lines of OsMAPK5 displayed constitutive PR gene expression and enhanced resistance to fungal and bacterial infection. In addition, the same lines also showed tolerance to drought, salt and cold stress (Xiong and Yang 2003).

Pathogenic signals also activate BWMPK1; rice MAPK that interestingly contains a TDY T-loop motif instead of the more common TEY motif and a long C-terminal domain necessary for kinase activity (He et al. 1999a; Cheong et al. 2003b). As mentioned earlier, BWMPK1 phosphorylates ethylene-responsive element-binding protein 1 and enhances the binding of a factor to the GCC box element found in the promoter regions of several PR genes.

The production of reactive oxygen species is known to occur upon pathogen attack and MAPKs that appear to mediate oxidative stresses have been identified (Apel and Hirt 2004; Pitzschke and Hirt 2006). Tobacco SIPK and WIPK were demonstrated to be activated by a variety of reactive oxygen species (Kumar and Klessig 2000; Samuel et al. 2000). Curiously, tobacco plants either over-expressing SIPK or in which SIPK expression had been suppressed both appeared hypersensitive to ozone, a treatment that is known to cause ROS accumulation in plants (Samuel and Ellis 2002). Also, it was shown that ozone activates MPK3 and MPK6 in *Arabidopsis* (Ahlfors et al. 2004).

The MEK2 pathway in tobacco plants has been linked to ROS generation via the activation of RBOH (respiratory burst oxidase orthologue), which produces ROS in response to fungal infection (Yoshioka et al. 2003). Furthermore, orthologs of tobacco MEK2 in *Arabidopsis*, MKK4 and MKK5, enhanced generation of hydrogen peroxide and cell death when constitutively activated (Ren et al. 2002). Relatedly, it was shown that



the *Arabidopsis* protein kinase OX11 is induced by ROSs and the fungal pathogen *Peronospora parasitica*, and is required for the activation of both MPK3 and MPK6 (Rentel et al. 2004).

Finally, the *Arabidopsis* MAPKKK MEKK1 has been shown to mediate redox homeostasis and itself be regulated by hydrogen peroxide in a proteasome-dependent manner (Nakagami et al. 2006). MEKK1-deficient plants accumulate ROSs and display aberrant regulation of a number of genes involved in cellular redox control. Interestingly, *mpk4* mutant plants showed similar phenotypes as *mekk1* mutant plants, and *mekk1* mutant lines were compromised in ROS-induced MPK4 activation. Thus, MEKK1 appears to be an upstream regulator of MPK4 (Nakagami et al. 2006).

## 2 Hormone Signaling

The hormone abscisic acid (ABA) acts to inhibit growth, promote dormancy and aid abiotic stress tolerance in plants (Giraudat 1995). In *Arabidopsis*, two MAPKs appear to be involved in ABA signaling in seedlings through the activation of the ABA-related transcription factor ABI5 (abscisic acid insensitive 5) (Lu et al. 2002). ABA also appears to elevate transcript, protein, and kinase activity levels of MAPK5 in rice leaves (Xiong and Yang 2003). MAPK5 is known to act as a positive regulator in abiotic stress tolerance and as a negative regulator of PR gene expression and broad-spectrum disease resistance in rice (Xiong and Yang 2003). A MAPK in pea is activated in guard cells by ABA, which is an important factor in guard cell signaling (Burnett et al. 2000; Schroeder et al. 2001). Furthermore, null mutations in the MAPKKK YODA led to excess stomata in *Arabidopsis* leaves, whereas constitutive activation of YODA eliminated stomata (Bergmann et al. 2004). Interestingly, it was reported that MPK4-silenced tobacco plants are hypersensitive to ozone due to an ABA-independent misregulation of stomatal closure, suggesting that MPK4 might function in the early stages of ROS signaling by controlling the entrance gate for environmental ozone uptake (Gomi et al. 2005).

Ethylene, a gaseous plant hormone, is involved in a multitude of physiological and developmental processes, such as the release from dormancy and shoots and root growth and differentiation (Chang 2003). As mentioned, the Raf-like MAPKKK CTR1

acts as a negative regulator of ethylene signaling and may be activated by the ethylene receptors ETR1 and ETR2 (Kieber et al. 1993). Furthermore, it was reported that CTR1 activates a 44 kDa MAPKK in maize protoplast and that ethylene also activates a 47 kDa MAPK protein in *Arabidopsis* (Novikova et al. 2000; Kovtun et al. 1998). Ouaked et al. (2003) also found that the ethylene precursor ACC could activate the kinase activity of SIMK and MMK3 in *Medicago* and MPK6 in *Arabidopsis* via mediation by SIMKK. The over-expression of SIMKK constitutively activated MPK6 and induced the expression of a number of ethylene-related target genes, indicating that the SIMKK-MPK6 pathway is a positive regulator of ethylene responses in *Arabidopsis* (Ouaked et al. 2003).

Liu and Zhang (2004) revealed that the activation of MPK6 induces ethylene biosynthesis in *Arabidopsis* by phosphorylating key enzymes in that process. The activity of MPK6 itself can be induced by active forms of the MAPKKs MKK4 and MKK5. The tobacco NtMEK2-SIPK/WIPK cascade plays a role in the induction of ethylene biosynthesis in response to wounding and viral infection (Kim et al. 2003a). A constitutively active form of NtMEK2 resulted in the rapid activation of endogenous SIPK and a dramatic increase in ethylene production, suggesting that the plant defense responses mediated by the NtMEK2-SIPK/WIPK pathway may rely on ethylene signaling rather than jasmonic acid or methyl jasmonate (Kim et al. 2003a).

Auxin is an essential plant hormone that regulates diverse processes, such as cell division and expansion, embryogenesis, meristem formation, root and leaf patterning, tropism and reproduction. Several lines of evidence implicate the presence of MAPK cascades in a variety of auxin-related pathways. For example, over-expression of the kinase domain from either NPK1 (a tobacco MAPKKK) or ANP1 (an *Arabidopsis* MAPKKK) results in both the suppression of auxin-induced gene expression and the activation of a number of specific stress-response genes (Kovtun et al. 1998, 2000). A MAPK cascade, that plays a role in auxin-induced adventitious rooting, has also been discovered (Pagnussat et al. 2004). Additionally, it was reported that increased expression of the MAPKK MKK7 in *Arabidopsis* causes deficiency in polar auxin transport and

leads to plant architectural abnormalities (Dai et al. 2006). Molecular genetic analysis of the *bud1* (bushy and dwarf1) mutant revealed that increased expression of MKK7 may be the cause for its phenotype, which includes fewer lateral roots, simpler venation patterns and a quicker and greater curvature in its gravitropic response. Over-expression and repression analyses indicate that MKK7 is a negative regulator of polar auxin transport in *Arabidopsis* (Dai et al. 2006).

### 3 Abiotic Stress Signaling

Many MAPKs are activated by abiotic stresses, including osmotic stress, cold, salt, drought, and wounding (Nakagami et al. 2005). In *Arabidopsis*, the MEKK1-MKK2-MPK4/MPK6 module was shown to be involved in cold and salt stress. MKK2 becomes activated by cold and salt stress, and *mkk2* mutants are hypersensitive to these stresses (Fig. 3) (Teige et al. 2004). MEKK1 is also induced by salt, drought, cold and wounding, where its gene products may interact with MKK1, MKK2, and MPK4 in forming a response to these stresses (Mizoguchi et al. 1996; Ichimura et al. 1998). Although MEKK1 can mediate pathogen-associated molecular pattern-induced activation of MPK3 and MPK6 through MKK4 and MKK5 (Asai et al. 2002), it can also activate MPK4 and MPK6 in an MKK2-dependent manner during abiotic stress (Teige et al. 2004). Furthermore, MKK1 appears to be involved in abiotic stress signaling as it is activated by wounding, cold, drought, and salt stress, while also being able to phosphorylate MPK4 (Fig. 3) (Matsuoka et al. 2002; Teige et al. 2004).

In alfalfa, MKK4 (a MAP kinase) gene expression and kinase activity are also activated by cold stress, drought and wounding, but not by heat or salt, in an apparently ABA-independent manner (Jonak et al. 1996; Bogre et al. 1997). In contrast, two other alfalfa MAP kinases, MKK2 and MKK3, were not activated under any of these stresses (Bogre et al. 1997) (The involvement of MAPKs in ABA pathway has been discussed in details in Chapter 3). It was also reported that SIMK (salt stress-inducible MAP kinase) can be activated by high concentrations of NaCl, KCl and sorbitol, and therefore may be involved in hyper-osmotic signaling (Munnik et al. 1999). SIMKK, which interacts with SIMK, was shown to enhance the salt-induced activation of SIMK in vivo, as well as in vitro (Kiegerl et al. 2000).

Finally, SIPK in tobacco has enhanced kinase activity after exposure to salt and osmotic stress, and MPK3 and MPK6 in *Arabidopsis* are also activated under hypo-osmolarity (Mikolajczyk et al. 2000; Droillard et al. 2002).

Ozone, a direct precursor of ROS, is a common response to virtually any biotic and abiotic stress. Ozone triggers a programmed cell death routine that is highly reminiscent of biotic defense programs, including the hyper-sensitive response and the synthesis of PR proteins (Overmyer et al. 2000). MAP kinases in plants have been shown to be activated by exposure to ozone (Samuel et al. 2000). In *Arabidopsis*, ozone exposure activates both MPK3 and MPK6, and leads to their nuclear translocation. RNA-interference lines of MPK3 and MPK6 both displayed phenotypes that included hypersensitivity to ozone (Miles et al. 2005). Additionally, MPK3 appears to be regulated by ozone at the transcriptional and translational levels (Ahlfors et al. 2004). Furthermore, ozone-exposed *red1* (radical-induced cell death 1) mutants showed increased salicylic acid levels and earlier activation of MPK6 compared to wild-type plants (Overmyer et al. 2005). It has also been demonstrated that the tobacco MAPKs SIPK and WIPK are activated by ozone and nitric oxide, although some oxidative stresses preferentially activate SIPK (Kumar and Klessig 2000; Samuel et al. 2000). Both over-expression and suppression of SIPK resulted in hypersensitivity to ozone treatment, and transgenic plants transformed with a constitutively active form of SIPKK, a SIPK-interacting MAPKK, showed enhanced ozone resistance (Samuel and Ellis 2002; Liu et al. 2000b; Miles et al. 2005). The tobacco MAP kinase MPK4 also appears to be involved in ozone response, as MPK4-silenced plants are hypersensitive to ozone.

## IV Calcium-Activated Protein Kinases

Changes in the cytosolic concentration of free calcium ( $Ca^{2+}$ ) precede a wide range of cellular and developmental processes in plants, including responses to biotic and abiotic stresses (Evans et al. 2001; Rudd and Franklin-Tong 2001; White and Broadley 2003). It is intriguing how a simple element like  $Ca^{2+}$  can act as a second messenger in so many different signal transduction pathways, and yet maintain a stimulus-specific response. A key to achieving this specificity appears to be the deceptive complexity of the calcium signal

itself, as well the diversity of proteins that bind calcium in these pathways.

Recent work has shown that in addition to concentration, calcium signals can differ in a number of temporal and spatial parameters including frequency, duration, and the subcellular localization of transient increases in concentration (Evans et al. 2001; Rudd and Franklin-Tong 2001; Sanders et al. 2002). These parameters allow plant cells to generate distinct  $\text{Ca}^{2+}$  “signatures” in response to disparate stimuli. To add further complexity to calcium-based signaling, the proteins that bind calcium to propagate a signal can also possess differential characteristics, such as  $\text{Ca}^{2+}$ -binding affinity, expression pattern, and subcellular localization. In this way, different  $\text{Ca}^{2+}$ -binding proteins can sense different stimulus-specific  $\text{Ca}^{2+}$  signatures and transduce the signal to distinct target proteins, thereby giving rise to the appropriate response.

To date, three major families of  $\text{Ca}^{2+}$  sensors in plants have been studied extensively: calcium-dependent protein kinases (CDPKs), calmodulin (CaM), and calcineurin B-Like proteins (CBLs). This section focuses on these families, as well as CDPK-related protein kinases (CRKs),  $\text{Ca}^{2+}$  and calmodulin-activated kinases (CCaMKs), and CBL-interacting protein kinases (CIPKs) (Fig. 4).

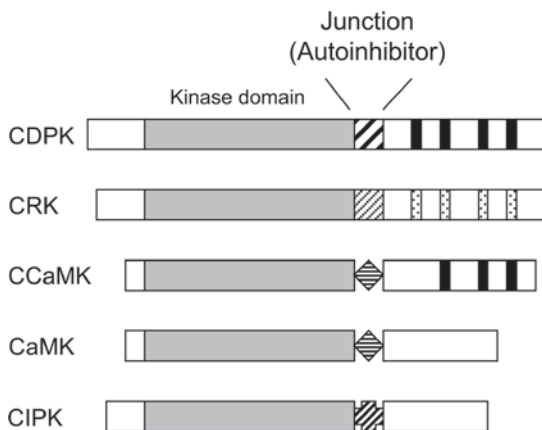

Fig. 4. Schematic diagrams of the protein kinase families regulated by  $\text{Ca}^{2+}$ . The gray and black boxes indicate kinase domains and canonical EF-hand motifs, respectively. The degenerated EF-hand motifs present in the C-terminal region of CRK are represented with the spotted boxes. The CDPK junction sequence carrying the autoinhibitory activity is shown with the hatched box. The CRK domain analogous to the CDPK junction is displayed with the box hatched with thinner lines. The hatched diamond and cross indicate the junction present in CCaMK/CaMK and CIPK, respectively.

## A Gene Families

### 1 CDPKs

Calcium-dependent protein kinases (CDPKs) can be classified as sensor-responders, because they consist of the C-terminal CaM-like  $\text{Ca}^{2+}$  sensor and the N-terminal kinase responder, which are connected by a junction sequence (Sanders et al. 2002). In the resting state, an autoinhibitory motif residing in the junction sequence inhibits CDPK serine/threonine kinase activity by the pseudo-substrate mechanism (Harmon et al. 1994). Upon  $\text{Ca}^{2+}$  binding, however, a CaM-like domain with four EF-hand motifs appears to disrupt the interaction between the autoinhibitor and the kinase region, which results in activation of the kinase activity (Cheng et al. 2002; Hrabak et al. 2003; Harper et al. 2004; Chandran et al. 2006). Although CDPKs have been found in plants and some protozoans, they have not been identified in animals.

A large number of genes constitute the CDPK family in higher plants, with 34 predicted CDPK genes in *Arabidopsis* and 29 in rice (Hrabak et al. 2003; Asano et al. 2005). A comparison of their genomic organization revealed that CDPK gene structure is highly conserved between the two higher plants (Asano et al. 2005). Among the 34 *Arabidopsis* CDPKs, 28 are known to carry the potential N-terminal myristoylation motif (MGXXXS/T) in which a 14-carbon saturated fatty acid, myristate, is covalently attached to a glycine residue (Cheng et al. 2002; Xiong et al. 2002; Hrabak et al. 2003). In addition, these CDPKs also possess a putative palmitoylation site, another type of lipid modification which adds a 16-carbon fatty acid, palmitate, to a cysteine residue through a thioester bond. In the case of rice CDPKs, 15 and 12 genes were respectively predicted to contain potential N-myristoylation and palmitoylation sites, which may mediate the membrane association of their proteins (Asano et al. 2005). In fact, some of the CDPK members from various plants such as potato, rice and *Arabidopsis* were empirically determined to be associated with membranes, including the plasma membrane, endoplasmic reticulum, and mitochondrial outer membrane (Pical et al. 1993; Martin and Busconi 2000; Lu and Hrabak 2002; Dammann et al. 2003). Meanwhile, other CDPK members have been found in various sub-cellular locations

such as the cytosol, nucleus, peroxisomes and oil bodies, among others (Patharkar and Cushman 2000; Yoo et al. 2002; Anil et al. 2003; Dammann et al. 2003; T. Zhang et al. 2005b).

In addition to the differences in sub-cellular localization, individual CDPK members appear to have distinct properties in terms of expression patterns,  $\text{Ca}^{2+}$ -binding affinities, and substrate specificities (Lee et al. 1998; White and Broadley 2003; Harper et al. 2004; Hernandez Sebastia et al. 2004; Rodriguez Milla et al. 2006). These features make it possible for CDPKs to mediate a number of disparate signal transduction pathways, including carbon and nitrogen metabolism, ion and water transport, ethylene synthesis, nodulation, developmental processes, and biotic and abiotic stress responses (Guenther et al. 2003; Hardin et al. 2003; Lee et al. 2003; Hernandez Sebastia et al. 2004; Ludwig et al. 2004; Harper and Harmon 2005; Leclercq et al. 2005; Gargantini et al. 2006). Recently, it has been also demonstrated that one of the CDPK family members phosphorylates NADPH oxidase, thereby regulating the production of reactive oxygen species (Kobayashi et al. 2007).

## 2 CRKs

Plants belonging to angiosperms contain another family of protein kinases called CRK, which stands for CDPK-related protein kinase. The *Arabidopsis* genome was predicted to contain eight CRK genes (Hrabak et al. 2003). Although the kinase domains of the CRK family members are most similar to those of CDPKs, their C-terminal domains differ from each other. CRKs, unlike CDPKs, have degenerated EF-hand motifs in their C-terminal regions, which lack  $\text{Ca}^{2+}$ -binding affinity (Lindzen and Choi 1995; Furumoto et al. 1996; Farmer and Choi 1999). Because CRKs cannot bind with  $\text{Ca}^{2+}$ , it is reasonable to speculate that the kinase activity of CRKs is not regulated directly by  $\text{Ca}^{2+}$ . In fact, in vitro kinase assays using CRKs from carrot and maize have demonstrated that the CRK isoforms are active regardless of  $\text{Ca}^{2+}$ , suggesting that an auto-inhibitory domain is not present in these CRK isoforms (Furumoto et al. 1996; Farmer and Choi 1999). However, it should be noted that some CRK family members can be modulated indirectly by  $\text{Ca}^{2+}$ . For example, two CRK isoforms of tobacco were

activated by association with  $\text{Ca}^{2+}$ -bound CaM (Hua et al. 2003). Interestingly, it appears that not all CaM-binding CRKs are activated by the interaction with  $\text{Ca}^{2+}$ -bound CaM. For example, the kinase activity of rice CRK, OsCBK, was not altered upon binding with  $\text{Ca}^{2+}$ /CaM (Zhang et al. 2002). Further investigation is required to reveal the role and function of the CRK family in plant stress response and development.

## 3 CCaMKs and CaMKs

Another protein kinase family that can bind  $\text{Ca}^{2+}$  is  $\text{Ca}^{2+}$  and calmodulin-activated kinases (CCaMKs). Their structural features contain an N-terminal serine/threonine protein kinase domain and a C-terminal regulatory region harboring a CaM-binding domain and three EF-hand  $\text{Ca}^{2+}$ -binding motifs (Patil et al. 1995; Liu et al. 1998). CCaMKs appear to require both  $\text{Ca}^{2+}$  and CaM for the activation of the kinase activity needed to phosphorylate substrates (Liu et al. 1998). Interestingly, CCaMKs, which have been identified from lily and tobacco, are not found in the *Arabidopsis* genome (Zhang and Lu 2003).

Animal and yeast cells are known to possess CaM-dependent protein kinases (CaMKs), which are activated by their interaction with CaM. In these cases, it appears that  $\text{Ca}^{2+}$ -bound CaM associates with an autoinhibitory domain of CaMK located at the C-terminal end of the kinase domain, which allows for the activation of kinase activity. However, plants do not appear to possess CaMKs, although there is a report that a CaMK-like protein kinase, CB1, was identified from apple (Watillon et al. 1993, 1995). Recent amino acid sequence analysis indicated that CB1, in fact, fits better in the CCaMK group rather than in the CaMK family (Hrabak et al. 2003).

## 4 CIPKs and CBLs

CBL-interacting protein kinases (CIPKs) are a novel family of serine/threonine protein kinases present only in plants. Although CIPKs themselves do not have the ability to directly bind with  $\text{Ca}^{2+}$ , their kinase activity can be modulated by  $\text{Ca}^{2+}$  through the interaction with calcineurin B-like  $\text{Ca}^{2+}$ -binding proteins (CBLs) (Shi et al. 1999; Halfter et al. 2000; Kim et al. 2000a;



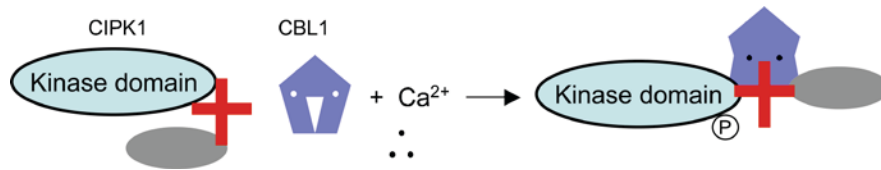

Fig. 5. Hypothetical model for the activation of CIPKs by the  $\text{Ca}^{2+}$ -bound CBLs. Upon  $\text{Ca}^{2+}$  binding, CBL1 (pentagon) undergoes conformational change and can interact with the NAF motif (cross) of CIPK1. The interaction disrupts the autoinhibition of CIPK1, resulting in activation of the kinase activity.

Albrecht et al. 2001; Kolukisaoglu et al. 2004; Jeong et al. 2005). Together, the CIPKs and CBLs appear to comprise a versatile mechanism for sensing and transducing calcium signals in plants (Fig. 5).

CBLs are a family of  $\text{Ca}^{2+}$  sensors that are most similar to the regulatory B subunit of the protein phosphatase calcineurins found in animals (Liu and Zhu 1998; Kudla et al. 1999). As with CaM, CBLs do not harbor intrinsic enzymatic activity of their own. Both *Arabidopsis* and rice appear to contain ten CBL genes each (Luan et al. 2002; Kolukisaoglu et al. 2004; Hwang et al. 2005). Although CBLs were originally predicted to contain three typical EF-hand motifs (Kudla et al. 1999), a non-conventional EF-hand motif present in the N-terminus (EF-1) was later shown to have  $\text{Ca}^{2+}$ -binding activity (Nagae et al. 2003). Since, the amino acid composition of the EF-hand motifs differs among the CBL family members, it is conceivable that each CBL may have a distinct  $\text{Ca}^{2+}$ -binding affinity (Nagae et al. 2003). Along with distinct  $\text{Ca}^{2+}$ -binding affinity, differential expression patterns and sub-cellular localizations of the CBL family members seem to determine which CBL members perceive a specific  $\text{Ca}^{2+}$  signal and relay it to interacting CIPK family members.

The *Arabidopsis* and rice genomes are predicted to encode 25 and 30 CIPK genes, respectively (Kolukisaoglu et al. 2004). Although the kinase domains of CIPKs are most related to those of the yeast SNF1 (sucrose non-fermenting 1) protein kinase and the mammalian AMP-dependent protein kinase, they contain a unique regulatory domain in their C-terminal regions (Shi et al. 1999). Due to this structural feature, the CIPK family has been also assigned to subgroup 3 of the SNF1-related kinase (SnRK3) in plants (Hrabak et al. 2003). The C-terminal regulatory region contains the NAF (or FISL) motif,

a stretch of about 21 amino acids conserved in the CIPK family members, and is both required and sufficient for interaction with CBL family members (Halfter et al. 2000; Kim et al. 2000a; Albrecht et al. 2001).

In vitro interaction assays demonstrated that CBL1 interacts with CIPK1 in a  $\text{Ca}^{2+}$ -dependent manner (Shi et al. 1999). In contrast, the complex formation between CBL4/SOS3 and CIPK24 (also known as SOS2) does not require  $\text{Ca}^{2+}$ , and yet  $\text{Ca}^{2+}$  is still necessary for the CBL4-CIPK24 complex to phosphorylate the synthetic peptide substrate p3 (Halfter et al. 2000). The different  $\text{Ca}^{2+}$  dependencies exhibited by the two CIPK-CBL pairs may be due to the difference in  $\text{Ca}^{2+}$ -binding affinities between CBL1 and CBL4. Regardless, it appears that CIPKs require  $\text{Ca}^{2+}$ -bound CBLs in order to phosphorylate substrates. The crystal structure of CBL2 showed that conformation of  $\text{Ca}^{2+}$ -bound CBL2 is markedly different from the unbound form (Nagae et al. 2003). Taken together, these findings suggest that  $\text{Ca}^{2+}$ -bound CBL undergoes a conformational change that subsequently elicits the structural alteration of the target CIPK, thereby activating the latter's kinase activity.

Studies with CIPK24 indicated that the C-terminal region covering the NAF motif binds to the N-terminal kinase region. Removal of the NAF motif and its downstream sequence resulted in the constitutive activation of its kinase activity (Guo et al. 2001). These findings suggest that the interaction between the kinase domain and the NAF-carrying regulatory domain may prevent the active site from binding with the substrate, and therefore the CIPK kinase is maintained in an inactive form. However, upon interaction with a  $\text{Ca}^{2+}$ -bound CBL partner, the CIPK undergoes a conformational change in which the NAF motif no longer exerts its inhibitory function,

thereby allowing the kinase domain to pursue its phosphorylation activity.

The kinase domain of the CIPK family contains a typical activation loop, a stretch of 30 amino acids bordered with conserved DFG and APA residues, which serves as a phosphorylation target for other protein kinases (Guo et al. 2001). In fact, changing the Ser156, Thr168 or Tyr175 residues to Asp within the activation loop resulted in constitutive activation of the CIPK protein kinase (Gong et al. 2002). It is also noteworthy that a superactive form of CIPK can be created by combining the substitution mutation in the activation loop with the deletion of the C-terminal regulatory domain (Guo et al. 2001). These findings strongly suggest that CIPK enzyme activity is modulated by at least two different molecular mechanisms: Ca<sup>2+</sup>-bound CBL and an as yet unidentified protein kinase.

Judging from the number of genes in the CBL and CIPK families, it is likely that some CBLs would have more than a single interacting CIPK partner. In fact, extensive studies using yeast two-hybrid assays have demonstrated that each of the CBL family members can interact specifically with only a subset of four to five CIPKs at different affinities (Kim et al. 2000a; Luan et al. 2002; Batistic and Kudla 2004; Kolukisaoglu et al. 2004; Jeong et al. 2005). Deletion analyses have provided structural basis for the interaction specificity. CBLs interacted more strongly with the N-terminal deleted CIPK mutants than with their full-length forms, suggesting that the N-terminal sequences upstream of the NAF motif carries inhibitory information to hinder interaction between the C-terminal region and CBL members (Shi et al. 1999; Kim et al. 2000a; Jeong et al. 2005). Further analyses with a series of CIPK5 deletion mutants have determined that the inhibitory information mainly resides in the 99-amino acid region located between the ninth sub-domain and the NAF motif (Kim et al. 2000a). As this region covers the most variable junction sequences in the CIPK family, it may explain why each CIPK member possesses distinct interaction affinities towards different CBL members. Taken together, it seems that the CIPK C-terminal domain carrying the NAF motif provides the structural platform for the actual binding with CBLs, and the variable junction sequence exhibits an inhibitory

effect which dictates the final interaction affinity towards particular CBLs. Such interaction specificity allows selective complex formation between CBLs and CIPKs even if they are present simultaneously in the same space. Thus, it is possible for plant cells to generate a number of distinct CBL-CIPK complexes at the same time, which can respectively play a role in different signaling pathways.

## B Functions of the CBL–CIPK Complexes

The CBL-CIPK Ca<sup>2+</sup>-signaling pathway is currently known to be involved in the response to a variety of external stimuli such as cold, drought, salinity, ABA, gibberellic acid, low K<sup>+</sup> concentration and high pH (Liu and Zhu 1998; Liu et al. 2000a; Cheong et al. 2003a; Kim et al. 2003b; Guo et al. 2004; Pandey et al. 2004; Hwang et al. 2005; Li et al. 2006; Xu et al. 2006; Fuglsang et al. 2007; Quan et al. 2007). Studies with *Arabidopsis* mutants have demonstrated that each pair of the CBL–CIPK complexes appears to execute a specific role in relaying different signals (Fig. 6).

### 1 Osmotic Stress

Several lines of evidence indicate that CIPK1 can form a complex with either CBL1 or its most closely related isoform CBL9, which are localized on the plasma membrane (Shi et al. 1999; Kim et al. 2000a; Albrecht et al. 2001; D'Angelo et al. 2006). In addition, loss-of-function *Arabidopsis* mutants lacking CBL1, CBL9 or CIPK1 exhibited hypersensitivity to high osmotic stress conditions (Pandey et al. 2004; D'Angelo et al. 2006). These findings suggest that the CBL1–CIPK1 and CBL9–CIPK1 complexes are involved in mediating osmotic stress responses, which are known to involve both ABA-dependent and ABA-independent signaling pathways. Interestingly, both the *cbl9* and *cipk1* mutants responded more sensitively to exogenous ABA than did wild type plants, whereas the *cbl1* mutant did not show significant changes in ABA responsiveness (Pandey et al. 2004; D'Angelo et al. 2006). Therefore, it appears that CIPK1 can act as a convergence point for ABA-dependent and ABA-independent osmotic stress responses by forming a complex with either CBL9 or CBL1, respectively.

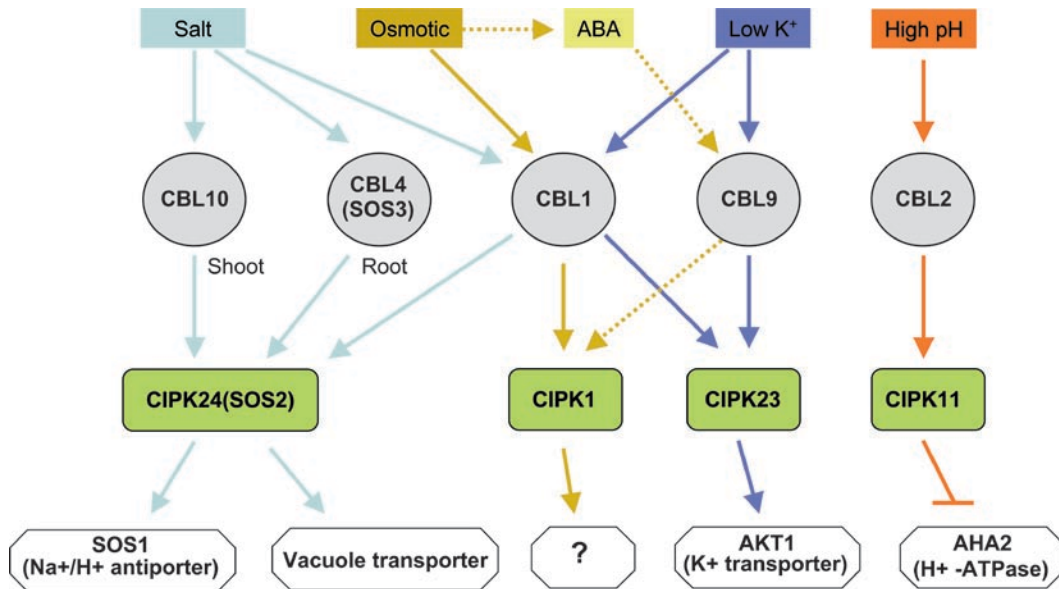

Fig. 6. The Calcineurin B-like protein (CBL) calcium sensor and CBL-interacting protein kinase (CIPK) signaling network is involved in various abiotic stress responses. Based on the results of genetic and molecular analyses, the model depicted was proposed. The different *line colors* indicate different stress signaling pathways [See Color Plate 3, Fig. 6].

## 2 Potassium Deficiency

In addition to osmotic stress, two research groups independently have shown that CBL1 and CBL9 are involved in potassium (K<sup>+</sup>) sensing. Their work has demonstrated that CBL1 and CBL9 can form complexes with CIPK23 in response to low concentrations of K<sup>+</sup> in the soil (Li et al. 2006; Xu et al. 2006). Based on their findings, they proposed a model for the potassium-deficiency response in plants: Low-K<sup>+</sup> conditions trigger changes in the cytosolic concentration of Ca<sup>2+</sup>, which is then sensed by the plasma membrane-localized calcium sensors CBL1 and CBL9. Ca<sup>2+</sup>-bound CBL1 and CBL9 then recruit CIPK23 to the plasma membrane and promote CIPK23 to phosphorylate the C-terminal region of the K<sup>+</sup> transporter AKT1, thereby enhancing its K<sup>+</sup>-transporting activity.

## 3 High pH

Recently, the CBL2–CIPK11 complex has been demonstrated to be involved in regulating the plasma membrane proton pump (PM H<sup>+</sup>-ATPase) (Fuglsang et al. 2007). It appears that CBL2 associates with and activates CIPK11 in the presence of cytosolic Ca<sup>2+</sup> signals elicited

by high external pH conditions. The activated CIPK11 then phosphorylates the Ser-931 residue in the C-terminal regulatory domain of the PM H<sup>+</sup>-ATPase AHA2, which inhibits AHA2 activity by preventing its interaction with an activating 14-3-3 protein.

## 4 Salt Stress

The CBL4–CIPK24 complex has been shown to be specifically involved in mediating Ca<sup>2+</sup> signals induced by salt stress (Halfter et al. 2000; Xiong et al. 2002; Guo et al. 2004). CBL4 and CIPK24 were originally known as SOS3 and SOS2, respectively. The term SOS stands for “salt overly sensitive”, which describes the phenotype of the *Arabidopsis* mutants with reduced salt tolerance (Zhu et al. 1998, see Chapter 11). Later, it was discovered that the genomic loci SOS3 and SOS2, respectively, encode polypeptides belonging to the CBL and CIPK families (Liu and Zhu 1998; Liu et al. 2000a). Subsequent biochemical and genetic analyses revealed that CBL4/SOS3 and CIPK24/SOS2 act together to mediate Ca<sup>2+</sup> signals involved in plant salt tolerance by modulating the phosphorylation activity of CIPK24/SOS2 with CBL4/SOS3 in a Ca<sup>2+</sup>-dependent manner (Halfter et al. 2000). In fact, the CBL4/SOS3–CIPK24/SOS2

complex phosphorylates and activates SOS1, a  $\text{Na}^+/\text{H}^+$  antiporter, in a  $\text{Ca}^{2+}$ -dependent manner. The activated SOS1 protein then functions to get rid of excess  $\text{Na}^+$  in plant cells, thereby conferring salt tolerance (Qiu et al. 2002; Quintero et al. 2002). Recently, Quan et al. (2007) have shown that CBL10 can also interact with CIPK24 in response to the salt stress. Although both CBL4 and CBL10 are involved in the same stress response, they appear to carry out their missions in different organs of *Arabidopsis* plants; CBL4 functions primarily in the root, whereas CBL10 activity is limited mainly to the shoot.

### 5 Novel Stress-Related Interactions

In order to gain further insight into the CBL-CIPK signaling network, it is essential to identify the *in vivo* substrate molecules that are phosphorylated by the CIPK family members. Only three CIPK substrates have been identified from *Arabidopsis* so far. As discussed, they are the membrane-bound proteins SOS1, AKT1 and AHA2 (Qiu et al. 2002; Quintero et al. 2002; Li et al. 2006; J. Xu et al. 2006; Fuglsang et al. 2007). However, according to mutant analyses, the CBL-CIPK  $\text{Ca}^{2+}$  signaling pathway has been shown to regulate the expression of several stress genes, including RD29A/B, Kin1/2, and DREB1A/B (Albrecht et al. 2003; Cheong et al. 2003a; Kim et al. 2003b; Pandey et al. 2004; D'Angelo et al. 2006). For example, *cb11* and *cb19* mutants exhibited altered expression patterns of the stress genes RD29A, RD29B, and Kin1, in response to drought (Albrecht et al. 2003; Cheong et al. 2003a; Pandey et al. 2004; D'Angelo et al. 2006). Because both CBL1 and CBL9 calcium sensors are bound to the plasma membrane and can recruit interacting CIPK partners, these results suggest that the membrane-bound CBL-CIPK complexes generated by cytosolic  $\text{Ca}^{2+}$  signals can communicate with the nucleus, where gene regulation occurs. Although little is known about how the CBL-CIPK complexes deliver cytoplasmic information into the nucleus, it seems reasonable to speculate that CIPK substrates and/or novel interactors might be the signal transducers carrying out this role.

Recently, the protein ECT1 has been predicted to be a novel interactor with CIPK1 due to the presence of an evolutionarily conserved C-terminal

domain, and is speculated to be involved in relaying signals from the membrane-bound CBL1-CIPK1 into the nucleus (Ok et al. 2005). Several lines of evidence provided by Ok et al. (2005) support this idea. First, both yeast two-hybrid and pull-down assays have demonstrated that ECT1 specifically interacts with CIPK1. According to deletion analyses, the CIPK1-ECT1 complex is formed through the direct interaction between the CIPK1 kinase domain and the evolutionarily conserved C-terminal domain of ECT1. However, ECT1 was not phosphorylated by CIPK1 *in vitro* regardless of  $\text{Ca}^{2+}$  and CBL1. Consequently, it seems that the CIPK1-ECT1 association itself would be an important factor in the signal transfer, as in the case of MEK1-MyoD (Perry et al. 2001). In the MEK1-MyoD association, the MEK1 protein kinase is known to repress MyoD activity, not via phosphorylation, but via physically binding to the N-terminal end of MyoD. Currently, however, the possibility that CIPK1 may phosphorylate ECT1 *in vivo* cannot be completely ruled out.

Second, the ECT1 protein can be localized in both the cytoplasm and the nucleus. The conserved C-terminal domain of ECT1 involved in the physical interaction with CIPK1 is also responsible for nuclear localization. Therefore, it is likely that interaction status between CIPK1 and ECT1, which can be affected by the CBL1-CIPK1 association, could exert influence on the subcellular localization of ECT1. Third, further yeast two-hybrid assays have demonstrated that ECT1 possesses auto-activation activity, suggesting that the ECT1 protein lacking the apparent DNA-binding motif may act as transcriptional coactivator. Finally, ECT1-like proteins are found only in eukaryotes such as yeasts, plants, and animals, but not in prokaryotes. Because  $\text{Ca}^{2+}$  acts as a ubiquitous signaling element in eukaryotic cells, such evolutionary conservation suggests that ECT1 may play a critical role in the CBL1-CIPK1  $\text{Ca}^{2+}$  signal transduction pathway.

At the present time, however, there is no solid evidence demonstrating that ECT1 actually receives the signal from the CBL1-CIPK1 complex and delivers it into the nucleus to regulate expression of the stress genes. Further molecular genetic and biochemical analyses will provide useful information necessary for unraveling the biological function of the ECT1 protein, and it will



certainly contribute to our understanding of how the membrane-bound CBL1–CIPK1 complex controls gene expression. Furthermore, because several specific CBL–CIPK complexes have been shown to function in particular stress-signaling pathways, fully elucidating the entire CBL–CIPK interacting network may shed great light on the mechanisms involved in a wide range of plant stress responses (Zhu 2002; Cheong et al. 2003a; Kim et al. 2003b; Guo et al. 2004; Pandey et al. 2004; Li et al. 2006; J. Xu et al. 2006).

## V Protein Phosphatases

Reversible protein phosphorylation is a primary regulatory mechanism in many prokaryotic and eukaryotic signaling pathways, including those involved in metabolism, the cell cycle, organismal growth and development and hormonal and environmental responses (Andreeva and Kutuzov 1999; Chernoff 1999; den Hertog 1999; Iten et al. 1999; Schillace and Scott 1999; Luan 2000, 2003). During phosphorylation, a protein kinase adds a phosphate group to a substrate. Protein phosphatases reverse this process by removing the added phosphate. In many cases, the addition or subtraction of a phosphate group to an enzyme will effectively either activate or deactivate the enzyme. In this manner, protein kinases and phosphatases play a critical role in controlling the activity of an enzyme and as a result, regulating the biochemical process in which the enzyme participates.

Traditionally, kinases are classified by the residues they phosphorylate. Some kinases phosphorylate serine or threonine residues, while others phosphorylate only tyrosine residues. A third class of kinases, known as dual-specificity kinases, can phosphorylate both serine/threonine and tyrosine residues. Despite the differences in the residues they target, most kinases share conserved structural features in their primary sequence (Hanks and Hunter 1995).

Similarly, phosphatases are classified into at least three distinct families. The protein phosphatase P (PPP) family and protein phosphatase M (PPM) family consist of serine/threonine phosphatases. The protein tyrosine phosphatase (PTP) family consists of both tyrosine-specific phosphatases, as well as dual-specificity phosphatases (dsPTPs) (Denu et al. 1996; Tonks and Neel 1996). How-

ever, even within the same family, significant structural diversity can be generated by the presence of unique regulatory and targeting domains or by the attachment of a regulatory subunit to the catalytic subunit. These additional features may localize the protein complex to a specific subcellular compartment, modulate the substrate specificity, or alter catalytic activity. While protein kinases and their functions have a long history of investigation, the number, diversity, and functions of protein phosphatases have become more appreciated in recent years (Luan 2000; Kerk et al. 2002; Luan 2003; Schweighofer et al. 2004; DeLong 2006).

### A Gene Families

#### 1 Protein Phosphatase P

The serine/threonine phosphatases initially were categorized into two groups, PP1 and PP2, based on their substrate specificity and pharmacological properties. The PP2 phosphatases were then further subdivided into three classes based on their dependence on divalent cations. PP2A phosphatases do not require divalent cations, while PP2B phosphatases require calcium, and PP2C phosphatases require magnesium (Luan 2003).

Subsequent sequence and structural analyses of the phosphatases revealed that PP1 phosphatases, as well as the PP2 subgroups PP2A and PP2B, are more closely related to each other than the PP2C phosphatases (Cohen 1989). For this reason, PP1, PP2A and PP2B are now referred to as the protein phosphatase P (PPP) family. PP2C and a few other serine/threonine phosphatases that are magnesium-dependent comprise a separate family of serine/threonine phosphatases, known as the protein phosphatase M (PPM) family (Fig. 7). Although PPP family members share little sequence similarity with PPM family members, the structural folds of the two families are strikingly similar (Luan 2003).

Early work with plant phosphatases included the identification of a multi-gene family in maize encoding PP1. Recombinant maize PP1 was shown to be affected by inhibitors in a similar fashion as its animal counterpart (Smith and Walker 1996). In *Nicotiana tabacum*, three PP1 cDNAs displaying different tissue-specific expression patterns were cloned (Suh et al. 1998). Additionally, a PP1 gene inducible by biotic stress was reported

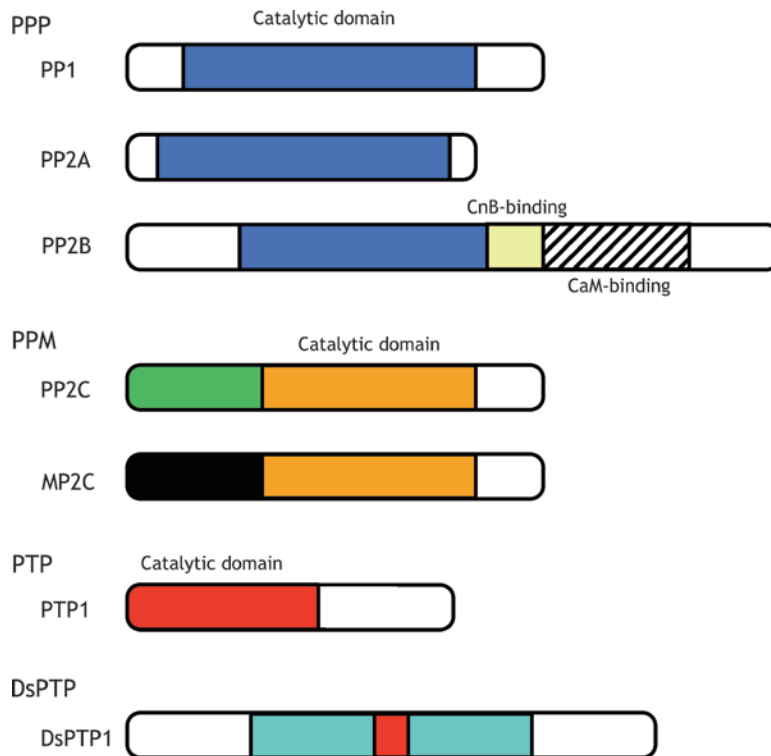

Fig. 7. Domain configurations of the known plant phosphatases. The PPP family members all have a catalytic domain of about 280 amino acids. The sequence of this domain is highly conserved among the members (40–60% identity). The PPM family (formerly PP2C) members have a catalytic domain that is less conserved (20–35% identity). The tyrosine phosphatase family consists of intracellular, single domain phosphatases, such as PTP1, and dual-specificity phosphatases, such as DsPTP1, whose catalytic domain, while shorter than the PTPs, still harbor the signature catalytic motif.

in *Phaseolus vulgaris* (Zimmerlin et al. 1995). In *Arabidopsis*, a family of nine PP1 genes has been identified (Smith and Walker 1993; Lin et al. 1998). Although functional evidence for these PP1 phosphatases has been difficult to obtain, work with a PP1 phosphatase in *Vicia faba* has demonstrated its involvement in stomatal opening during the response to blue light (Takemiya et al. 2006).

Animal PP2A phosphatases usually exist as a heterodimer composed of a catalytic C-subunit and a regulatory A-subunit, or as a heterotrimer with the addition of a regulatory B-subunit (Smith and Walker 1996). Genes encoding PP2A catalytic and regulatory subunits have been identified in plants. For example, PP2A catalytic subunit genes have been found in *Brassica napus*, alfalfa, and *Arabidopsis* (Mackintosh et al. 1990; Pirck et al. 1993; Arino et al. 1993; Casamayor et al. 1994). The deduced amino acid sequences

for these subunits have approximately 80% identity with their animal homologs. In addition, both regulatory A and B subunits have been found in plants, and these subunits share approximately 70% similarity with the animal versions (Garbers et al. 1996; Latorre et al. 1997; Rundle et al. 1995; Slabas et al. 1994; White et al. 2002). Five genes encoding the PP2A catalytic subunit have been identified in rice. Interestingly, these genes are expressed ubiquitously in all tissues, while three of the genes also display differential expression under abiotic stress (Yu et al. 2003, 2005).

Despite the fact that PP2B-like activity has been reported in plants, genes encoding the catalytic subunit of PP2B-type phosphatases have yet to be found in plants (Allen and Sanders 1995; Bethke and Jones 1997; Luan et al. 1993; Pardo et al. 1998). However, a multigene family found in *Arabidopsis* and rice appears to encode a set of proteins that resemble animal PP2B regulatory

B-subunits (Kudla et al. 1999; Luan et al. 2002; Kolukisaoglu et al. 2004). In contrast to phosphatases, these calcineurin B-like proteins (CBLs) target a set of kinases known as CBL-interacting protein kinases (CIPKs) to form a unique plant signaling system involved in abscisic acid and abiotic stress signaling (Kudla et al. 1999; Shi et al. 1999; Luan et al. 2002; Cheong et al. 2003a; Kim et al. 2003b; Kolukisaoglu et al. 2004; Pandey et al. 2004).

## 2 Protein Phosphatase M

The protein phosphatase M family of serine/threonine phosphatases includes the PP2C phosphatases, as well as several serine/threonine phosphatases that depend on magnesium binding for activation. PP2C is the largest group of protein phosphatases in plants, with 76 PP2C genes in *Arabidopsis* alone (Kerk et al. 2002). In contrast, only a few PP2C isoforms have been found in animals. An analysis of the *Arabidopsis* PP2C genes show that the majority of them cluster into ten classes, denoted as groups A through J, with a few singleton genes that did not fall into any distinct class (Schweighofer et al. 2004). Little functional information is available for many of the genes in most of the PP2C groups. Experimental results so far have shown that most of the ABA-associated PP2C genes appear to fall into group A. Members of group B are homologs of an alfalfa PP2C known as MP2C, which has been shown to regulate MAPK signaling. The poltergeist phosphatase gene (POL) in *Arabidopsis* clusters into group C. POL has been shown to be involved in flower development via the CLAVATA pathway. CLAVATA1 is a receptor-like kinase that regulates meristem activity. As mentioned, the functionality found in the remaining PP2C groups remains elusive.

## 3 Protein Tyrosine Phosphatases

As indicated by their name, protein tyrosine phosphatases have the capacity to dephosphorylate tyrosine residues. In animals, reversible tyrosine phosphorylation serves as a common mechanism by which growth factors and cytokines regulate cellular proliferation and differentiation (Darnell 1997; Hunter 2000). Based on phosphoamino-acid specificity, PTPs fall into one of two groups:

tyrosine-specific PTPs and dual-specificity PTPs (DsPTPs) (Fig. 7). The difference between the two groups is that the latter can dephosphorylate phosphoserine/threonine, as well as phosphotyrosine (Stone and Dixon 1994; Tonks and Neel 1996).

The tyrosine-specific PTPs can be further categorized into receptor-like PTPs and intracellular PTPs. The receptor-like PTPs generally have a putative extracellular ligand-binding domain, a single transmembrane region, and one or two cytoplasmic PTP domains. Intracellular PTPs such as PTP1B and SHP1 contain a single catalytic domain and various amino or carboxyl terminal extensions, including SH2 domains that have targeting or regulatory functions. Examples of dual-specificity phosphatases include the MAP kinase phosphatases, the cell cycle regulator cdc25 phosphatases (Dunphy 1994) and the tumor suppressor PTEN (Maehama et al. 2001). All PTPs are characterized by their sensitivity to vanadate, ability to hydrolyze p-nitrophenyl phosphate, insensitivity to okadaic acid, and lack of a metal ion requirement for catalysis.

While it was well established that PTPs play critical signaling roles in animals, a typical tyrosine kinase had not been identified in plants or fungi until relatively recently. The first tyrosine phosphatase, AtPTP1, was characterized in *Arabidopsis* in 1998, and PTPs similar to AtPTP1 subsequently have been found in other plants (Xu et al. 1998; Fordham-Skelton et al. 1999). Similarly, the first dual-specificity phosphatase, AtDsPTP1, was also identified in *Arabidopsis* (Gupta et al. 1998). After the sequencing of the *Arabidopsis* genome, initial sequence searches identified a number of genes that encode proteins with a typical PTP catalytic core motif, although the enzymatic properties of their products must still be determined (Kerk et al. 2002). Compared to the 100 or more PTPs encoded in the human genome, there are only about a half a dozen found in yeast and approximately 20 putative PTPs in *Arabidopsis*. Among these 20 genes, only one encodes a tyrosine-specific PTP (AtPTP1), while the remaining appear to encode DsPTPs (Kerk et al. 2002; <http://nature.berkeley.edu/luanlab/PTPs/List.html>).

Sequence analysis suggests that AtPTP1 is a member of the cytoplasmic PTPs. AtPTP1 contains a typical catalytic core motif in its C-terminal and an N-terminal extension of unknown identity.

It was demonstrated that recombinant AtPTP1 protein specifically dephosphorylates phosphotyrosine but not phosphoserine/threonine in a protein substrate. Like other PTPs, the cysteinyl residue in the signature motif is essential for the catalytic activity of recombinant AtPTP1. Furthermore, specific inhibitors for PTPs, such as vanadate, inhibit AtPTP1 activity (Xu et al. 1998).

The dual-specificity PTP from *Arabidopsis*, AtDsPTP1, is similar to the animal MKPs and is capable of dephosphorylating both phosphotyrosine and phosphoserine/threonine (Gupta et al. 1998). Other than the signature motif in their catalytic core, AtPTP1 and AtDsPTP1 share little sequence similarity.

## B Functions

### 1 Hormone Signaling and Development

A number of plant phosphatases are involved in hormone signaling and developmental processes in plants, including PP2A-, PP2C-, and DsPTP-type phosphatases. In *Arabidopsis*, the RCN1 gene encodes a 65 kDa regulatory A subunit of PP2A, which appears to play a role in the regulation of auxin transport (Garbers et al. 1996). Mutations in RCN1 resulted in a number of alterations, including defects in root curling, hypocotyl hook formation, differential cell elongation, gravitropic response, and basipetal auxin transport (Deruere et al. 1999; Rashotte et al. 2001). Also, auxin transport in the *rcn1* mutant is more sensitive to the polar transport inhibitor naphthylphthalamic acid (Garbers et al. 1996). Assays of protein extracts from *rcn1* mutants link the mutations to reduced PP2A activity (Deruere et al. 1999). Another development-related PP2A phosphatase is encoded by the TON2 gene in *Arabidopsis*. Mutant versions of TON2 display abnormalities in cell shape that result in changes in overall plant morphology (Camilleri et al. 2002).

Several *Arabidopsis* genes encode homologs of the animal DsPTPs known as PTENs (phosphatase and tensin homologs), which have the capacity to act as tumor suppressors (Fruman et al. 1998; Maehama et al. 2001). In contrast to its animal counterparts, *Arabidopsis* PTEN1 appears to be essential for pollen development (Gupta et al. 2002). Experimental results show that AtPTEN1 is specifically expressed in pollen

grains and is required for pollen maturation after cell division (Gupta et al. 2002). Further efforts to identify the physiological substrate of plant PTENs hopefully will shed light on the mechanism underlying PTEN function in plant cells.

Extensive work with several PP2C-type phosphatases has demonstrated their clear involvement in ABA signaling. Two members of the Group A PP2C phosphatases, ABI1 and ABI2, have been identified as negative regulators of the ABA signal transduction pathway (Rodriguez 1998; Sheen 1998; Gosti et al. 1999; Merlot et al. 2001). ABI1 and ABI2 mutants display a number of defects in ABA-related processes, including stomatal regulation, seed dormancy and germination, and drought stress response. Plants in which ABI1 was ectopically expressed displayed ABA-insensitivity while studies of loss-of-function revertants of *abi1-1*, a dominant ABA-insensitive mutant, resulted in ABA-hypersensitive plants (Sheen 1998; Merlot et al. 2001). Additionally, work with ABI1 and ABI2 mutants showed disruptions in ABA-elicited ROS production, as well as ABA-induced calcium channel activation, in guard cells (Allen et al. 1999; Murata et al. 2001). Possible mechanisms by which ABI1 and ABI2 participate in ABA-related signaling have been uncovered through the discovery of their interactions with other proteins. For instance, it appears that ABI2 and to a lesser degree, ABI1, are components of a protein complex that negatively regulates ABA-signaling. The proposed complex involves the protein kinase PKS3/CIPK15 and a Ca<sup>2+</sup>-binding protein known as SCaBP5/CBL1 (Guo et al. 2002). Mutant lines of PKS3/CIPK15 and SCaBP5/CBL1 display an ABA hypersensitive phenotype during seed germination and seedling growth, while mutant ABI1 and ABI2 lines suppress this phenotype. ABI1 has also been shown to interact with an ABA-inducible transcription factor known as ATHB6 and phospholipase D alpha 1-derivative phosphatidic acid (PLD-derived PA), which appears to tether ABI1 to the plasma membrane (Himmelbach et al. 2002; Zhang et al. 2004). One possible model for this interaction is that ABI1 negatively regulates ABA signaling by translocating to the nucleus and activating ATHB6. To prevent this effect, PLD-derived PA restricts the nuclear translocation of ABI1 by binding it to the plasma membrane.



HAB1 (AtP2C-HAB1) is another PP2C-type phosphatase that is involved in ABA signaling. A homolog of ABI1 and ABI2, HAB1 is strongly inducible by ABA and is expressed broadly throughout the plant (Rodriguez 1998; Leonhardt et al. 2004; Saez et al. 2004). Mutant HAB1 lines display an ABA hypersensitive phenotype during seed germination and enhanced ABA-mediated stomatal closure. Overexpression of HAB1 caused ABA insensitivity in both seeds and vegetative tissues, in addition to impaired stomatal closure, enhanced ABA-resistant root growth, and reduced expression of ABA-induced genes. Based on these lines of evidence, HAB1 is a likely negative regulator of ABA signaling. Interestingly, HAB1 and ABI1 double mutant lines had increased responsiveness to ABA, suggesting that the two phosphatases may cooperate in the negative regulation of ABA signaling (Saez et al. 2006).

Another A-type PP2C, AtPP2CA, also appears to regulate ABA signaling. When transiently expressed in protoplasts, AtPP2CA blocks ABA signal transduction (Sheen 1998). In addition, ABA, as well as cold, drought, and salt, induce AtPP2CA expression. Of these, cold and drought-induced expression appears to be ABA dependent, and the drought-induced expression also appears to be ABI1 dependent. Via its catalytic domain, AtPP2CA interacts with the AKT2/AKT3 potassium channel and has been shown to modulate the activity of the channel in mammalian cells and *Xenopus* oocytes (Vranova et al. 2001; Cherel et al. 2002). Like AtPP2CA, AKT2 gene expression is regulated by ABA, and AKT2 and AtPP2CA display similar tissue-specific expression patterns.

Finally, a mutant allele of the dual-specificity phosphatase PHS1, results in a 50% reduction in PHS1 transcript. Analysis of this line has shown phenotypic evidence of the involvement of PHS1 in ABA signaling, including ABA hypersensitivity during germination, reduced stomatal aperture, and inhibition of light-regulated stomatal opening (Quettier et al. 2006).

## 2 MAPK Interactions

In mammals and yeast, phosphatases have been shown to be important components of MAPK-related signaling pathways. Generally, MAP

kinases are activated by the phosphorylation of threonine and tyrosine residues in their kinase activation domains (Ahn et al. 1992). Activated MAP kinases can then propagate a signal through the phosphorylation of downstream signaling components. In many cases, the signaling cascade is deactivated by the dephosphorylation of MAP kinases. Studies have shown that both tyrosine-specific and dual-specificity phosphatases serve to dephosphorylate MAPKs, and thereby act as important regulators of MAPK-based pathways (Keyse 1995, 1998; Wurgler-Murphy and Saito 1997; Zhan et al. 1997).

Experiments in *Arabidopsis* and alfalfa have revealed that a similar relationship between MAPKs and phosphatases exists in plants. Earlier, it had been shown that tyrosine-specific phosphorylation is associated with plant MAPKs (Suzuki and Shinshi 1995). Work with the *Arabidopsis* MAPK known as MPK4 and a protein tyrosine phosphatase, PTP1, provided evidence that the phosphorylated, active form of MPK4 can be reversed through the PTP1-dependent dephosphorylation of MPK4 (Huang et al. 2000). Furthermore, it appears that the activation of several MAPK isoforms is significantly more robust in a *ptp1* knockout mutant than in wild-type plants, whereas overexpression of PTP1 results in delayed activation of these kinases in the transgenic plants (R. Gupta and S. Luan, unpublished data). In alfalfa, a PP2C in known as MP2C was shown to inactivate stress-induced MAPK (SIMK) through the dephosphorylation of the threonine residue of the pTEpY motif of SIMK (Bogre et al. 1997; Meskiene et al. 1998a, b, 2003). Finally, screens for UV-sensitive mutants in *Arabidopsis* led to the identification of a putative DsPTP, named MKP1, as essential for UV resistance. The mutant plants appear to have higher MAPK activity under UV illumination, implicating MKP1 as a negative regulator of MAPKs in UV response (Ulm et al. 2001).

## 3 Novel Interactions

The involvement of tyrosine-specific and dual-specificity phosphatases in plant physiological processes extends beyond MAPK-related signaling cascades. For example, one study found that PTP activity is essential for stomatal closure induced by ABA, external calcium, darkness or

H<sub>2</sub>O<sub>2</sub> (MacRobbie 2002). These inducers most likely regulate stomatal closure by changing intracellular calcium concentrations, which then triggers the activity of potassium channels located in the tonoplast and plasma membrane (Ward et al. 1995; Pei et al. 2000; Sai and Johnson 2002). Several PTP-specific inhibitors were shown to alter potassium efflux from guard cell vacuoles, although plasma membrane fluxes were left unchanged. Interestingly, MAPKs do not appear to be involved in this process, as MAP kinase inhibitors did not alter ABA-induced potassium efflux from the vacuole (MacRobbie 2002).

DSP4, a dual-specificity phosphatase in *Arabidopsis*, has been shown to bind starch and interact with AKIN11, a SNF 1-related kinase (SnRK) (Fordham-Skelton et al. 2002; Kerk et al. 2006). A detailed analysis of a loss-of-function DSP4 mutant provided evidence that it regulates starch degradation in the chloroplast, while itself being regulated by light, pH and redox state (Sokolov et al. 2006). Dual-specificity phosphatases may also be involved in plant cell division. It was shown that a yeast DsPTP known as CDC25 can activate cell division in plant cells, most likely via a plant CDC2 kinase (Zhang et al. 1996). While no plant homologue of yeast CDC25 has been found to date, it may well be that another DsPTP family member provides CDC25 functionality in plants. Another remaining mystery revolves around actin and pro-filin, both of which are non-MAPK targets of tyrosine phosphorylation in plants (Guillen et al. 1999; Kameyama et al. 2000). While it is likely that either tyrosine-specific or dual-specificity phosphatases are involved in regulating phosphorylated actin and pro-filin, specific phosphatases that provide this functionality have yet to be identified.

## VI Conclusions

By controlling the phosphorylation status of other proteins, protein kinases and phosphatases play a fundamental role in coordinating the activity of many known signal transduction pathways in both prokaryotic and eukaryotic organisms. Here, we have reviewed the major gene families known to encode protein kinases and phosphatases involved in stress-related signal transduction in plants. While recent progress has started to link

individual kinases and phosphatases to particular stress pathways, several broad challenges await. Of course, an immediate goal is to map each kinase and phosphatase to individual signaling pathways. Next, it will be important to understand which kinases and phosphatases work together in controlling pathway activity. In order to do so, we need to identify the substrates upon which these enzymes act. To fully understand the biological role of these kinases and phosphatases in a given pathway, we also need to investigate the effects that each phosphorylation event has on signal strength, duration, and specificity. Finally, the ultimate challenge is to fully detail how each network of kinases and phosphatases, substrates, phosphorylation states, and phosphorylation-dependent activity culminate in the ability of a plant to cope with a particular environmental stress.

## Acknowledgements

The work in authors' laboratory is supported by The National Science Foundation, US Department of Agriculture, and by a grant from the Korean Research Foundation (KRF-2006-331-C00261 to Y.H.C.)

## References

- Agrawal GK, Iwahashi H, Rakwal R (2003) Rice MAPKs. *Biochem Biophys Res Commun* 302:171–180
- Ahlfors R, Macioszek V, Rudd J, Brosche M, Schlichting R, Scheel D, Kangasjarvi J (2004) Stress hormone-independent activation and nuclear translocation of mitogen-activated protein kinases in *Arabidopsis thaliana* during ozone exposure. *Plant J* 40:512–522
- Ahn NG, Seger R, Krebs EG (1992) The mitogen-activated protein kinase activator. *Curr Opin Cell Biol* 4:992–999
- Albrecht V, Ritz O, Linder S, Harter K, Kudla J (2001) The NAF domain defines a novel protein-protein interaction module conserved in Ca<sup>2+</sup>-regulated kinases. *EMBO J* 20:1051–1063
- Albrecht V, Weigl S, Blazevic D, D'Angelo C, Batistic O, Kolukisaoglu U, Bock R, Schulz B, Harter K, Kudla J (2003) The calcium sensor CBL1 integrates plant responses to abiotic stresses. *Plant J* 36:457–470
- Allen GJ, Sanders D (1995) Calcineurin, a type 2B protein phosphatase, modulates the Ca<sup>2+</sup>-permeable slow vacuolar ion channel of stomatal guard cells. *Plant Cell* 7:1473–1483

- Allen GJ, Kuchitsu K, Chu SP, Murata Y, Schroeder JI (1999) Arabidopsis *abi1-1* and *abi2-1* phosphatase mutations reduce abscisic acid-induced cytoplasmic calcium rises in guard cells. *Plant Cell* 11:1785–1798
- Anderson CM, Wagner TA, Perret M, He ZH, He D, Kohorn BD (2001) WAKs: cell wall-associated kinases linking the cytoplasm to the extracellular matrix. *Plant Mol Biol* 47:197–206
- Andreasson E, Jenkins T, Brodersen P, Thorgrimsen S, Petersen NH, Zhu S, Qiu JL, Micheelsen P, Rocher A, Petersen M, Newman MA, Bjorn Nielsen H, Hirt H, Somssich I, Mattsson O, Mundy J (2005) The MAP kinase substrate MKS1 is a regulator of plant defense responses. *EMBO J* 24:2579–2589
- Andreeva AV, Kutuzov MA (1999) RdgC/PP5-related phosphatases: novel components in signal transduction. *Cell Signal* 11:555–562
- Anil VS, Harmon AC, Rao KS (2003) Temporal association of Ca<sup>2+</sup>-dependent protein kinase with oil bodies during seed development in *Santalum album* L.: its biochemical characterization and significance. *Plant Cell Physiol* 44:367–376
- Apel K, Hirt H (2004) Reactive oxygen species: metabolism, oxidative stress and signal transduction. *Annu Rev Plant Biol* 55:373–399
- Arino J, Perez-Callejon E, Cunillera N, Camps M, Posas F, Ferrer A (1993) Protein phosphatases in higher plants multiplicity of Type 2a phosphatases in *Arabidopsis thaliana*. *Plant Mol Biol* 21:475–485
- Asai T, Tena G, Plotnikova J, Willmann MR, Chiu WL, Gomez-Gomez L, Boller T, Ausubel FM, Sheen J (2002) MAP Kinase signalling cascade in *Arabidopsis* innate immunity. *Nature* 415:977–983
- Asano T, Tanaka N, Yang G, Hayashi N, Komatsu S (2005) Genome-wide identification of the rice calcium-dependent protein kinase and its closely related kinase gene families: comprehensive analysis of the CDPKs gene family in rice. *Plant Cell Physiol* 46:356–366
- Bassett CL, Nickerson ML, Cohen RA, Rajeevan MS (2000) Alternative transcript initiation and novel post-transcriptional processing of a leucine-rich repeat receptor-like protein kinase gene that responds to short-day photoperiodic floral induction in morning glory (*Ipomoea nil*). *Plant Mol Biol* 43:43–58
- Bateman A, Bycroft M (2000) The structure of a LysM domain from *E. coli* membrane-bound lytic murine transglycosylase D (MltD). *J Mol Biol* 299:1113–1119
- Batistic O, Kudla J (2004) Integration and channeling of calcium signaling through the CBL calcium sensor/CIPK protein kinase network. *Planta* 219:915–924
- Becraft PW, Stinard PS, McCarty DR (1996) CRINKLY4: A TNFR-like receptor kinase involved in maize epidermal differentiation. *Science* 273:1406–1409
- Belkhadir Y, Chory J (2006) Brassinosteroid signaling: a paradigm for steroid hormone signaling from the cell surface. *Science* 314:1410–1411
- Bergmann DC, Lukowitz W, Somerville CR, (2004) Stomatal development and pattern controlled by a MAPKK kinase. *Science* 304:1494–1497
- Bethke PC, Jones RL (1997) Reversible protein phosphorylation regulates the activity of the slow-vacuolar ion channel. *Plant J* 11:1227–1235
- Bogre L, Ligterink W, Meskiene I, Barker PJ, Heberle-Bors E, Huskisson NS, Hirt H (1997) Wounding induces the rapid and transient activation of a specific MAP kinase pathway. *Plant Cell* 9:75–83
- Bogre L, Calderini O, Binarova P, Mattauch M, Till S, Kiegl S, Jonak C, Pollaschek C, Barker P, Huskisson NS, Hirt H, Heberle-Bors E (1999) A MAP Kinase is activated late in plant mitosis and becomes localized to the plane of cell division. *Plant Cell* 11:101–113
- Brand U, Fletcher JC, Hobe M, Meyerowitz EM, Simon R (2000) Dependence of stem cell fate in *Arabidopsis* on a feedback loop regulated by CLV3 activity. *Science* 289:617–619
- Brodersen P, Petersen M, Bjorn Nielsen H, Zhu S, Newman MA, Shokat KM, Rietz S, Parker J, Mundy J (2006) *Arabidopsis* MAP Kinase 4 regulates salicylic acid- and jasmonic acid/ethylene-dependent responses via EDS1 and PAD4. *Plant J* 47:532–546
- Burnett EC, Desikan R, Moser RC, Neill SJ (2000) ABA activation of an MBP kinase in *Pisum sativum* epidermal peels correlates with stomatal responses to ABA. *J Exp Bot* 51:197–205
- Calderini O, Bogre L, Vicente O, Binarova P, Heberle-Bors E, Wilson C (1998) A cell cycle regulated MAP Kinase with a possible role in cytokinesis in tobacco cells. *J Cell Sci* 111:3091–3100
- Calderini O, Glab N, Bergounioux C, Heberle-Bor E, Wilson C (2001) A novel tobacco mitogen-activated protein (MAP) kinase, NtMEK1, activates the cell cycle-regulated p43Ntf6 MAP kinase. *J Biol Chem* 276:18139–18145
- Camilleri C, Azimzadeh J, Pastuglia M, Bellini C, Grandjean O, Bouchez D (2002) The *Arabidopsis* TONNEAU2 gene encodes a putative novel protein phosphatase 2A regulatory subunit essential for the control of the cortical cytoskeleton. *Plant Cell* 14:833–845
- Canales C, Bhatt AM, Scott R, Dickinson H (2002) EXS, a putative LRR receptor kinase, regulates male germline cell number and tapetal identity and promotes seed development in *Arabidopsis*. *Curr Biol* 12:1718–1727
- Cano-Delgado A, Yin Y, Yu C, Vafeados D, Mora-Garcia S, Cheng JC, Nam KH, Li J, Chory J (2004) BRL1 and BRL3 are novel brassinosteroid receptors that function in vascular differentiation in *Arabidopsis*. *Development* 131:5341–5351
- Cardinale F, Meskiene I, Ouaked F, Hirt H (2002) Convergence and divergence of stress-induced mitogen-activated protein kinase signaling pathways at the level of two distinct mitogen-activated protein kinase kinases. *Plant Cell* 14:703–711

- Casamayor A, Perez-Callejon E, Pujol G, Arino J, Ferrer A (1994) Molecular characterization of a fourth isoform of the catalytic subunit of protein phosphatase 2A from *Arabidopsis thaliana*. *Plant Mol Biol* 26:523–528
- Chandran V, Stollar EJ, Lindorff-Larsen K, Harper JF, Chazin WJ, Dobson CM, Luisi BF, Christodoulou J (2006) Structure of the regulatory apparatus of a calcium-dependent protein kinase (CDPK): a novel mode of calmodulin-target recognition. *J Mol Biol* 357:400–410
- Chang C (2003) Ethylene signaling: the MAPK module has finally landed. *Trends Plant Sci* 8:365–368
- Chang L, Karin M (2001) Mammalian MAP kinase signaling cascades. *Nature* 410:37–40
- Chen X, Shang J, Chen D, Lei C, Zou Y, Zhai W, Liu G, Xu J, Ling Z, Cao G, Ma B, Wang Y, Zhao X, Li S, Zhu L (2006) A B-lectin receptor kinase gene conferring rice blast resistance. *Plant J* 46:794–804
- Cheng SH, Willmann MR, Chen HC, Sheen J (2002) Calcium signaling through protein kinases. The *Arabidopsis* calcium-dependent protein kinase gene family. *Plant Physiol* 129:469–485
- Cheong YH, Kim KN, Pandey GK, Gupta R, Grant JJ, Luan S (2003a) CBL1, a calcium sensor that differentially regulates salt, drought and cold responses in *Arabidopsis*. *Plant Cell* 15:1833–1845
- Cheong YH, Moon BC, Kim JK, Kim CY, Kim MC, Kim IH, Park CY, Kim JC, Park BO, Koo SC, Yoon HW, Chung WS, Lim CO, Lee SY, Cho MJ (2003b) BWMK1, a rice mitogen-activated protein kinase, locates in the nucleus and mediates pathogenesis-related gene expression by activation of a transcription factor. *Plant Physiol* 132:1961–1972
- Cherel I, Michard E, Platet N, Mouline K, Alcon C, Sentenac H, Thibaud JB (2002) Physical and functional interaction of the *Arabidopsis* K<sup>+</sup> channel AKT2 and phosphatase AtPP2CA. *Plant Cell* 14:1133–1146
- Chernoff J (1999) Protein tyrosine phosphatases as negative regulators of mitogenic signaling. *J Cell Physiol* 180:173–181
- Chinchilla D, Bauer Z, Regenass M, Boller T, Felix G (2006) The *Arabidopsis* receptor kinase FLS2 binds flg22 and determines the specificity of flagellin perception. *Plant Cell* 18:465–476
- Chono M, Honda I, Zeniya H, Yoneyama K, Saisho D, Takeda K, Takatsuto S, Hoshino T, Watanabe Y (2003) A semi-dwarf phenotype of barley uzu results from a nucleotide substitution in the gene encoding a putative brassinosteroid receptor. *Plant Physiol* 133:1209–1219
- Clark SE, Running MP, Meyerowitz EM (1993) CLAVATA1, a regulator of meristem and flower development in *Arabidopsis*. *Development* 119:397–418
- Clark SE, Williams RW, Meyerowitz EM (1997) The CLAVATA1 gene encodes a putative receptor kinase that controls shoot and floral meristem size in *Arabidopsis*. *Cell* 89:575–585
- Clouse SD, Sasse JM (1998) Brassinosteroids: essential regulators of plant growth and development. *Annu Rev Plant Physiol Plant Mol Biol* 49:427–451
- Clouse SD, Langford M, McMorris TC (1996) A brassinosteroid-insensitive mutant in *Arabidopsis thaliana* exhibits multiple defects in growth and development. *Plant Physiol* 111:671–678
- Cohen P. (1989) The structure and regulation of protein phosphatases. *Annu Rev.; biochem* 58:453–508
- Dai Y, Wang H, Li B, Huang J, Liu X, Zhou Y, Mou Z, Li J (2006) Increased expression of MAP kinase kinase7 causes deficiency in polar auxin transport and leads to plant architectural abnormality in *Arabidopsis*. *Plant Cell* 18:308–320
- Dammann C, Ichida A, Hong B, Romanowsky SM, Hrabak EM, Harmon AC, Pickard BG, Harper JF (2003) Sub-cellular targeting of nine calcium-dependent protein kinase isoforms from *Arabidopsis*. *Plant Physiol* 132:1840–1848
- D'Angelo C, Weinl S, Batistic O, Pandey GK, Cheong YH, Schultke S, Albrecht V, Ehlert B, Schulz B, Harter K, Luan S, Bock R, Kudla J (2006) Alternative complex formation of the Ca-regulated protein kinase CIPK1 controls abscisic acid-dependent and independent stress responses in *Arabidopsis*. *Plant J* 48:857–872
- Darnell JE Jr (1997) STATs and gene regulation. *Science* 277:1630–1635
- den Hertog J (1999) Protein-tyrosine phosphatases in development. *Mech Dev* 85:3–14
- DeLong A. (2006) Switching the flip: protein phosphatase roles in signaling pathways. *Curr Opin Plant Biol* 9:470–7.
- Denu JM, Stuckey JA, Saper MA, Dixon JE (1996) Form and function in protein dephosphorylation. *Cell* 87:361–64
- Deruere J, Jackson K, Garbers C, Soll D, DeLong A (1999) The RCN1-encoded A subunit of protein phosphatase 2A increases phosphatase activity in vivo. *Plant J* 20:389–399
- Desikan R, Hancock JT, Ichimura K, Shinozaki K, Neill SJ (2001) Harpin induces activation of the *Arabidopsis* mitogen-activated protein kinases AtMPK4 and AtMPK6. *Plant Physiol* 126:1579–1587
- DeYoung BJ, Bickle KL, Schrage KJ, Muskett P, Patel K, Clark SE (2006) The CLAVATA1-related BAM1, BAM2 and BAM3 receptor kinase-like proteins are required for meristem function in *Arabidopsis*. *Plant J* 45:1–16
- Dievart A, Clark SE (2004) LRR-containing receptors regulating plant development and defense. *Development* 131:251–261
- Droillard M, Boudsocq M, Barbier-Brygoo H, Lauriere C (2002) Different protein kinase families are activated by osmotic stresses in *Arabidopsis thaliana* cell suspensions – involvement of the MAP kinases AtMPK3 and AtMPK6. *FEBS Lett* 527:43–50
- Dunphy WG. (1994) The decision to enter mitosis. *Trends Cell Biol.* 4:202–7.



- Endre G, Kereszt A, Kevei Z, Mihacea S, Kalo P, Kiss GB (2002) A receptor kinase gene regulating symbiotic nodule development. *Nature* 417:962–966
- Epstein J, Eichbaum Q, Sheriff S, Ezekowitz RA (1996) The collectins in innate immunity. *Curr Opin Immunol* 8:29–35
- Evans NH, McAinsh MR, Hetherington AM (2001) Calcium oscillations in higher plants. *Curr Opin Plant Biol* 4:415–420
- Farmer PK, Choi JH (1999) Calcium and phospholipid activation of a recombinant calcium-dependent protein kinase (DcCPK1) from carrot (*Daucus carota* L.). *Biochem Biophys Acta* 1434:6–17
- Feuillet C, Schachermayr G, Keller B (1997) Molecular cloning of a new receptor-like kinase gene encoded at the Lr10 disease resistance locus of wheat. *Plant J* 11:45–52
- Fordham-Skelton AR, Skipsey M, Eveans IM, Edwards R, Gatehouse JA (1999) Higher plant tyrosine-specific protein phosphatases (PTPs) contain novel amino-terminal domains: expression during embryogenesis. *Plant Mol Biol* 39:593–605
- Fordham-Skelton AP, Chilley P, Lumbreras V, Reignoux S, Fenton TR, Dahm C, Pages M, Gatehouse JA (2002) A novel higher plant protein tyrosine phosphatase interacts with SNF1-related protein kinases via a KIS (kinase interaction sequence) domain. *Plant J* 29:705–715
- Fruman DA, Meyers RE, Cantley LC (1998) Phosphoinositide kinases. *Annu Rev Biochem* 67:481–507
- Frye CA, Tang D, Innes RW (2001) From the cover: negative regulation of defense responses in plants by a conserved MAPKK kinase. *Proc Natl Acad Sci USA* 98:373–378
- Fuglsang AT, Guo Y, Cui TA, Qiu Q, Song C, Kristiansen KA, Bych K, Schulz A, Shabala S, Schumaker KS, Palmgren MG, Zhu JK (2007) Arabidopsis protein kinase PKS5 inhibits the plasma membrane H<sup>+</sup>-ATPase by preventing interaction with 14-3-3 protein. *Plant Cell* 19:1617–1634
- Furumoto T, Ogawa N, Hata S, Izui K (1996) Plant calcium-dependent protein kinase-related kinases (CRKs) do not require calcium for their activities. *FEBS Lett* 396:147–151
- Garbers C, DeLong A, Deruere J, Bernasconi P, Soll D (1996) A mutation in protein phosphatase 2A regulatory subunit A affects auxin transport in *Arabidopsis*. *EMBO J* 15:2115–2124
- Gargantini PR, Gonzalez-Rizzo S, Chinchilla D, Raices M, Giammaria V, Ulloa RM, Frugier F, Crespi MD (2006) A CDPK isoform participates in the regulation of nodule number in *Medicago truncatula*. *Plant J* 48:843–856
- Giraudat J (1995) Abscisic acid signaling. *Curr Opin Cell Biol* 7:232–238
- Gomez-Gomez L, Boller T (2000) FLS2, an LRR receptor-like kinase involved in the perception of the bacterial elicitor flagellin in *Arabidopsis*. *Mol Cell* 5:1003–1011
- Gomez-Gomez L, Felix G, Boller T (1999) A single locus determines sensitivity to bacterial flagellin in *Arabidopsis thaliana*. *Plant J* 18:277–284
- Gomez-Gomez L, Bauer Z, Boller T (2001) Both the extracellular leucine-rich repeat domain and the kinase activity of FLS2 are required for flagellin binding and signaling in *Arabidopsis*. *Plant Cell* 13:1155–1163
- Gomi K, Ogawa D, Katou S, Kamada H, Nakajima N, Saji H, Soyano T, Sasabe M, Machida Y, Mitsuhashi I, Ohashi Y, Seo S (2005) A mitogen-activated protein kinase NtMPK4 activated by SIPKK is required for jasmonic acid signaling and involved in ozone tolerance via stomatal movement in tobacco. *Plant Cell Physiol* 46:1902–1914
- Gong D, Guo Y, Jagendorf AT, Zhu JK (2002) Biochemical characterization of the *Arabidopsis* protein kinase SOS2 that functions in salt tolerance. *Plant Physiol* 130:256–264
- Gonzalez-Garcia MP, Rodriguez D, Nicolas C, Rodriguez PL, Nicolas G, Lorenzo O (2003) Negative regulation of abscisic acid signaling by the *Fagus sylvatica* FsPP2C1 plays a role in seed dormancy regulation and promotion of seed germination. *Plant Physiol* 133:135–144
- Gosti F, Beaudoin N, Serizet C, Webb AAR, Vartanian N, Giraudat J (1999) ABI1 protein phosphatase 2C is a negative regulator of abscisic acid signaling. *Plant Cell* 11:1897–1909
- Guenther JF, Chanmanivone N, Galetovic MP, Wallace IS, Cobb JA, Roberts DM (2003) Phosphorylation of soybean nodulin 26 on serine 262 enhances water permeability and is regulated developmentally and by osmotic signals. *Plant Cell* 15:981–991
- Guillen G, Valdes-Lopez V, Noguez R (1999) Profilin in *Phaseolus vulgaris* is encoded by two genes (only one expressed in root nodules) but multiple isoforms are generated in vivo by phosphorylation on tyrosine residues. *Plant J* 19:497–508
- Guo Y, Halfter U, Ishitani M, Zhu JK (2001) Molecular characterization of functional domains in the protein kinase SOS2 that is required for plant salt tolerance. *Plant Cell* 13:1383–1400
- Guo Y, Xiong L, Song CP, Gong D, Halfter U, Zhu JK (2002) A calcium sensor and its interacting protein kinase are global regulators of abscisic acid signaling in *Arabidopsis*. *Dev Cell* 3:233–244
- Guo Y, Qiu QS, Quintero FJ, Pardo JM, Ohta M, Zhang C, Schumaker KS, Zhu JK (2004) Transgenic evaluation of activated mutant alleles of SOS2 reveals a critical requirement for its kinase activity and C-terminal regulatory domain for salt tolerance in *Arabidopsis thaliana*. *Plant Cell* 16:435–449
- Gupta R, Huang Y, Kieber J, Luan S (1998) Identification of a dual-specificity protein phosphatase that inactivates a MAP Kinase from *Arabidopsis*. *Plant J* 16:581–595
- Gupta R, Ting T, Sokolov L, Johnson SJ, Luan S (2002) AtPTEN1, a tumor suppressor homologue essential for pollen development in *Arabidopsis*. *Plant Cell* 14:2495–2507
- Halfter U, Ishitani M, Zhu JK (2000) The *Arabidopsis* SOS2 protein kinase physically interacts with and is activated

- by the calcium-binding protein SOS3. *Proc Natl Acad Sci USA* 97:3735–3740
- Hamel LP, Nicole MC, Sritubtim S, Morency MJ, Ellis M, Ehltng J, Beaudoin N, Barbazuk B, Klessig D, Lee J, Martin G, Mundy J, Ohashi Y, Scheel D, Sheen J, Xing T, Zhang S, Seguin A, Ellis BE (2006) Ancient signals: comparative genomics of plant MAPK and MAPKK gene families. *Trends Plant Sci* 11:192–198
- Handford ZRP, Mayhew M, Knott V, Brownlee GG, Stuart D (1995) The structure of a Ca<sup>2+</sup>-binding epidermal growth factor-like domain: its role in protein-protein interaction. *Cell* 82:131–141
- Hanks SK, Hunter T (1995) Protein kinases 6- The eukaryotic protein kinase superfamily: kinase (catalytic) domain structure and classification. *FASEB J* 9:576–596
- Hanks SK, Quinn AM, Hunter T (1998) The protein kinase family: conserved features and deduced phylogeny of the catalytic domains. *Science* 241:42–52
- Hardin SC, Tang GQ, Scholz A, Holtgraewe D, Winter H, Huber SC (2003) Phosphorylation of sucrose synthase at serine 170: occurrence and possible role as a signal for proteolysis. *Plant J* 35:588–603
- Harmon AC, Yoo BC, McCaffery C (1994) Pseudosubstrate inhibition of CDPK, a protein kinase with a calmodulin-like domain. *Biochemistry* 33:7278–7287
- Harper JF, Harmon A (2005) Plants, symbiosis and parasites: a calcium signalling connection. *Nat Rev Mol Cell Biol* 6:555–566
- Harper JF, Breton G, Harmon A (2004) Decoding Ca<sup>2+</sup> signals through plant protein kinases. *Annu Rev Plant Biol* 55:263–288
- Haubrick LL, Assmann SM (2006) Brassinosteroids and plant function: some clues, more puzzles. *Plant Cell Environ* 29:446–457
- Hawgood S, Poulain F (2001) The pulmonary collectins and surfactant metabolism. *Annu Rev Physiol* 63:495–519
- He C, Fong SH, Yang D, Wang GL (1999a) BWMK1, a novel MAP kinase induced by fungal infection and mechanical wounding in rice. *Mol Plant Microbe Interact* 12:1064–1073
- He JX, Gendron JM, Yang Y, Li J, Wang ZY (2002) The GSK3-like kinase BIN2 phosphorylates and destabilizes BZR1, a positive regulator of the brassinosteroid signaling pathway in *Arabidopsis*. *Proc Natl Acad Sci USA* 99:10185–10190
- He Z, Wang ZY, Li J, Zhu Q, Lamb C, Ronald P, Chory J (2000) Perception of brassinosteroids by the extracellular domain of the receptor kinase BRI1. *Science* 288:2360–2363
- He ZH, Fujiki M, Kohorn BD (1996) A cell wall associated receptor-like protein kinase. *J Biol Chem* 271:19789–19793
- He ZH, He D, Kohorn BD (1998) Requirement for the induced expression of a cell wall associated receptor kinase for survival during the pathogen response. *Plant J* 14:55–63
- He ZH, Cheeseman I, He D, Kohorn BD (1999b) A cluster of five cell wall associated receptor kinase genes, Wak1–5, are expressed in specific organs of *Arabidopsis*. *Plant Mol Biol* 39:1189–1196
- Hecht V, Vielle-Calzada JP, Hartog MV, Schmidt ED, Boutilier K, Grossniklaus U, de Vries SC (2001) The *Arabidopsis* somatic embryogenesis receptor kinase 1 gene is expressed in developing ovules and embryos and enhances embryogenic competence in culture. *Plant Physiol* 127:803–816
- Hernandez Sebastia C, Hardin SC, Clouse SD, Kieber JJ, Huber SC (2004) Identification of a new motif for CDPK phosphorylation in vitro that suggests ACC synthase may be a CDPK substrate. *Arch Biochem Biophys* 428:81–91
- Herskowitz I (1995) MAP Kinase pathways in yeast: for mating and more. *Cell* 80:187–197
- Herve C, Dabos P, Galaud JP, Rouge P, Lescure B (1996) Characterization of an *Arabidopsis thaliana* gene that defines a new class of putative plant receptor kinases with an extracellular lectin-like domain. *J Mol Biol* 258:778–788
- Hester G, Kaku HG, Goldstein IJ, Wright CS (1995) Structure of mannose-specific snowdrop (*Galanthus nivalis*) lectin in representative of a new plant lectin family. *Nat Struct Biol* 2:472–479
- Himmelbach A, Hoffmann T, Leube M, Höhener B, Grill E (2002) Homeodomain protein ATHB6 is a target of the protein phosphatase ABI1 and regulates hormone responses in *Arabidopsis*. *EMBO J* 21:3029–3038
- Hou X, Tong H, Selby J, Dewitt J, Peng X, He ZH (2005) Involvement of a cell wall-associated kinase, WAKL4, in *Arabidopsis* mineral responses. *Plant Physiol* 139:1704–1716
- Hrabak EM, Chan CW, Gribskov M, Harper JF, Choi JH, Halford N, Kudla J, Luan S, Nimmo HG, Sussman MR, Thomas M, Walker-Simmons K, Zhu JK, Harmon AC (2003) The *Arabidopsis* CDPK-SnRK superfamily of protein kinases. *Plant Physiol* 132:666–680
- Hua W, Liang S, Lu YT (2003) A tobacco (*Nicotiana tabacum*) calmodulin-binding protein kinase, NtCBK2, is regulated differentially by calmodulin isoforms. *Biochem J* 376:291–302
- Huang Y, Li H, Gupta R, Morris PC, Luan S, Kieber JJ (2000) ATMPK4, an *Arabidopsis* homolog of mitogen activated protein kinase, is activated in vitro by AtMEK1 through threonine phosphorylation. *Plant Physiol* 122:1301–1310
- Hunter T (2000) Signaling: 2000 and beyond. *Cell* 100:113–127
- Huse M, Kuriyan J (2002) The conformational plasticity of protein kinases. *Cell* 109:275–282
- Hwang YS, Bethke PC, Cheong YHS, Zhu T, Jones RL (2005) A gibberellin-regulated calcineurin B in rice localizes to the tonoplast and is implicated in vacuole function. *Plant Physiol* 138:1347–1358
- Ichimura K, Mizoguchi T, Irie K, Morris P, Giraudat J, Matsumoto K, Shinozaki K (1998) Isolation of AtMEKK1 (a MAP kinase kinase kinase) – interacting proteins and analysis of a MAP Kinase cascade in *Arabidopsis*. *Biochem Biophys Res Commun* 253:532–543

- Ichimura K, Mizoguchi T, Yoshida R, Yuasa T, Shinozaki K (2000) Various abiotic stresses rapidly activate *Arabidopsis* MAP Kinases AtMPK4 and AtMPK6. *Plant J* 24:655–665
- Ichimura K, Casais C, Peck SC, Shinozaki K, Shirasu K (2006) MEKK1 is required for MPK4 activation and regulates tissue-specific and temperature-dependent cell death in *Arabidopsis*. *J Biol Chem* 281:36969–36976
- Iten M, Hoffmann TM, Grill E (1999) Receptors and signaling components of plant hormones. *J Recept Signal Transduct Res* 19:41–58
- Jeong HJ, Jwa NS, Kim KN (2005) Identification and characterization of protein kinase that interact with the CBL3 calcium sensor in *Arabidopsis*. *Plant Sci* 169:1125–1135
- Jin H, Axtell MJ, Dahlbeck D, Ekwenna O, Zhang S, Staskawicz B, Baker B (2002) NPK1, an MEKK1-like mitogen-activated protein kinase kinase kinase, regulates innate immunity and development in plants. *Dev Cell* 3:291–297
- Jin H, Liu Y, Yang KY, Kim CY, Baker B, Zhang S (2003) Function of a mitogen-activated protein kinase pathway in N gene-mediated resistance in tobacco. *Plant J* 33:719–731
- Jinn TS, Stone JM, Walker JC (2000) HAESA, an *Arabidopsis* leucine-rich repeat receptor kinase, controls floral organ abscission. *Genes Dev* 14:108–117
- Johnson KL, Ingram GC (2005) Sending the right signals: regulating receptor kinase activity. *Curr Opin Plant Biol* 8:648–656
- Johnson LN, Noble MEM, Owen DJ (1996) Active and inactive protein kinases: structural basis for regulation. *Cell* 85:149–158
- Jonak C, Heberle-Bors E, Hirt H (1994) MAP kinases: universal multi-purpose signaling tools. *Plant Mol Biol* 24:407–416
- Jonak C, Kiegerl S, Ligterink W, Barker PJ, Huskisson NS, Hirt H (1996) Stress signaling in plants: a mitogen-activated protein kinase pathway is activated by cold and drought. *Proc Natl Acad Sci USA* 93:11274–11279
- Jonak C, Okresz L, Bogre L, Hirt H (2002) Complexity, cross talk and integration of plant MAP kinase signaling. *Curr Opin Plant Biol* 5:415–424
- Kajava AV, Kobe B (2002) Assessment of the ability to model proteins with leucine-rich repeats in light of the latest structural information. *Protein Sci* 11:1082–1090
- Kameyama K, Kishi Y, Yoshimura M, Kanzawa N, Sameshima M, Tsuchiya T (2000) Tyrosine phosphorylation and plant bending. *Nature* 407:437
- Katou S, Yoshioka H, Kawakita K, Rowland O, Jones JDG, Mori H, Doke N (2005) Involvement of PPS3 phosphorylated by elicitor-responsive mitogen-activated protein kinases in the regulation of plant cell death. *Plant Physiol* 139:1914–1926
- Kerk D, Bulgrein J, Smith DW, Barsam B, Veretnik S et al (2002) The complement of protein phosphatase catalytic subunits encoded in the genome of *Arabidopsis*. *Plant Physiol* 129:908–925
- Kerk D, Conley TR, Rodriguez FA, Tran HT, Nimick M, Muench DG, Moorhead GB (2006) A chloroplast-localized dual-specificity protein phosphatase in *Arabidopsis* contains a phylogenetically dispersed and ancient carbohydrate-binding domain, which binds the polysaccharide starch. *Plant J* 46:400–413
- Keyse SM (1995) An emerging family of dual specificity MAP kinase phosphatases. *Biochim Biophys Acta* 1265:2–3
- Keyse SM (1998) Protein phosphatases and the regulation of MAP kinase activity semin. *Cell Dev Biol* 9:143–152
- Kieber JJ, Rothenberg M, Roman G, Feldmann KA, Ecker JR (1993) CTR1, a negative regulator of the ethylene response pathway in *Arabidopsis*, encodes a member of the raf family of protein kinase. *Cell* 72:427–441
- Kiegerl S, Cardinale F, Siligan C, Gross A, Baudouin E, Liwosz A, Eklof S, Till S, Bogre L, Hirt H, Meskiene I (2000) SIMKK, a mitogen-activated protein kinase (MAPK) kinase, is a specific activator of the salt stress-induced MAPK, SIMK. *Plant Cell* 12:2247–2258
- Kim CY, Zhang S (2004) Activation of a mitogen-activated protein kinase cascade induces WRKY family of transcription factors and defense genes in tobacco. *Plant J* 38:142–151
- Kim CY, Liu Y, Thorne ET, Yang H, Fukushige H, Gassmann W, Hildebrand D, Sharp RE, Zhang S (2003a) Activation of a stress-responsive mitogen-activated protein kinase cascade induces the biosynthesis of ethylene in plants. *Plant Cell* 15:2707–2718
- Kim KN, Cheong YH, Gupta R, Luan S (2000a) Interaction specificity of *Arabidopsis* calcineurin B-like calcium sensors and their target kinases. *Plant Physiol* 124:1844–1853
- Kim KN, Cheong YH, Grant JJ, Pandey GK, Luan S (2003b) CIPK3, a calcium sensor-associated protein kinase that regulates abscisic acid and cold signal transduction in *Arabidopsis*. *Plant Cell* 15:411–423
- Kim YS, Lee JH, Yoon GM, Cho HS, Park SW, Suh MC, Choi D, Ha HJ, Liu JR, Pai HS (2000b) CHRK1, a chitinase-related receptor-like kinase in tobacco. *Plant Physiol* 123:905–915
- Kobayashi M, Ohura I, Kawakita K, Yokota N, Fujiwara M, Shimamoto K, Doke N, Yoshioka H (2007) Calcium-dependent protein kinases regulate the production of reactive oxygen species by potato NADPH oxidase. *Plant Cell* 19:1065–1080
- Kobe B, Deisenhofer J (1995) A structural basis of the interactions between leucine-rich repeats and protein ligands. *Nature* 374:183–186
- Kobe B, Kajava AV (2001) The leucine-rich repeat as a protein recognition motif. *Curr Opin Struct Biol* 11:725–732
- Kohorn BD, Kobayashi M, Johansen S, Riese J, Huang LF, Koch K, Fu S, Dotson A, Byers N (2006) An *Arabidopsis* cell wall-associated kinase required for invertase activity and cell growth. *Plant J* 46:307–316

- Kolkisaoglu U, Weini S, Blazevic D, Batistic O, Kudla J (2004) Calcium sensors and their interacting protein kinases: genomics of the *Arabidopsis* and rice CBL-CIPK signaling networks. *Plant Physiol* 134:43–58
- Kovtun Y, Chiu W, Zeng W, Sheen J (1998) Suppression of auxin signal transduction by a MAPK cascade in higher plants. *Nature* 395:716–720
- Kovtun Y, Chiu W, Tena G, Sheen J (2000) Functional analysis of oxidative stress-activated mitogen-activated protein kinase cascade in plants. *Proc Natl Acad Sci USA* 97:2940–2945
- Krusell L, Madsen LH, Sato S, Aubert G, Genua A, Szczygłowski K, Duc G, Kaneko T, Tabata S, de Bruijn F, Pajuelo E, Sandal N, Stougaard J (2002) Shoot control of root development and nodulation is mediated by a receptor-like kinase. *Nature* 420:422–426
- Krysan PJ, Jester PJ, Gottwald JR, Sussman MR (2002) An *Arabidopsis* mitogen-activated protein kinase kinase gene family encodes essential positive regulators of cytokinesis. *Plant Cell* 14:1109–1120
- Kudla J, Xu Q, Harter K, Gruissem W, Luan S (1999) Genes for calcineurin B-like proteins in *Arabidopsis* are differentially regulated by stress signals. *Proc Natl Acad Sci USA* 96:4718–4723
- Kuhn JM, Boisson-Dernier A, Dizon MB, Maktabi MH, Schroeder JI (2006) The protein phosphatase AtPP2CA negatively regulates abscisic acid signal transduction in *Arabidopsis*, and effects of abh1 on AtPP2CA mRNA. *Plant Physiol* 140:127–139
- Kumar D, Klessig DF (2000) Differential induction of tobacco MAP kinases by the defense signals nitric oxide, salicylic acid, ethylene and jasmonic acid. *Mol Plant Microbe Interact* 13:347–351
- Kwak SH, Shen R, Schiefelbein J (2005) Positional signaling mediated by a receptor-like kinase in *Arabidopsis*. *Science* 307:1111–1113
- Latorre KA, Harris DM, Rundle SJ (1997) Differential expression of three *Arabidopsis* genes encoding the B regulatory subunit of protein phosphatase 2A. *Eur J Biochem* 245:156–163
- Leclercq J, Ranty B, Sanchez-Ballesta MT, Li Z, Jones B, Jauneau A, Pech JC, Latched A, Ranjeva R, Bouzayen M (2005) Molecular and biochemical characterization of LeCRK1, a ripening-associated tomato CDPK-related kinase. *J Exp Bot* 56:25–35
- Lee J, Klessig DF, Nürnberger T (2001) A hairpin binding site in tobacco plasma membranes mediates activation of the pathogenesis-related gene HIN1 independent of extracellular calcium but dependent on mitogen-activated protein kinase activity. *Plant Cell* 13:1079–1093
- Lee JY, Yoo BC, Harmon AC (1998) Kinetic and calcium-binding properties of three calcium-dependent protein kinase isoenzymes from soybean. *Biochemistry* 37:6801–6809
- Lee SS, Cho HS, Yoon GM, Ahn JW, Kim HH, Pai HS (2003) Interaction of NtCDPK1 calcium-dependent protein kinase with NtRpn3 regulatory subunit of the 26S proteasome in *Nicotiana glauca*. *Plant J* 33:825–840
- Lee SW, Han SW, Bartley LE, Ronald PC (2006) Unique characteristics of *Xanthomonas oryzae* pv. *oryzae* AvrXa21 and implications for plant innate immunity. *Proc Natl Acad Sci USA* 103:18395–18400
- Leonhardt N, Kwak JM, Robert N, Waner D, Leonhardt G, Schroeder JI (2004) Microarray expression analyses of *Arabidopsis* guard cells and isolation of a recessive abscisic acid hypersensitive protein phosphatase2C mutant. *Plant Cell* 16:596–615
- Lewis TS, Shapiro PS, Ahn NG (1998) Signal transduction through MAP kinase cascades. *Adv Cancer Res* 74:49–139
- Li J, Chory J (1997) A putative leucine-rich repeat receptor kinase involved in brassinosteroid signal transduction. *Cell* 90:929–938
- Li J, Wen J, Lease KA, Doke JT, Tax FE, Walker JC (2002) BAK1, an *Arabidopsis* LRR receptor-like protein kinase, interacts with BRI1 and modulates brassinosteroid signaling. *Cell* 110:213–222
- Li L, Kim BG, Cheong YH, Pandey GK, Luan S (2006) A Ca<sup>2+</sup> signaling pathway regulates a K<sup>+</sup> channel for low-K response in *Arabidopsis*. *Proc Natl Acad Sci USA* 103:12625–12630
- Lin Q, Li J, Smith RD, Walker JC (1998) Molecular cloning and chromosomal mapping of type one serine/threonine protein phosphatases in *Arabidopsis thaliana*. *Plant Mol Biol* 37:471–481
- Lindzen E, Choi JH (1995) A carrot cDNA encoding an atypical protein kinase homologous to plant calcium-dependent protein kinases. *Plant Mol Biol* 28:785–797
- Liu J, Zhu JK (1998) A calcium sensor homolog required for plant salt tolerance. *Science* 280:1943–1945
- Liu J, Ishitani M, Halfter U, Kim CS, Zhu JK (2000a) The *Arabidopsis thaliana* SOS2 gene encodes a protein kinase that is required for salt tolerance. *Proc Natl Acad Sci USA* 97:3730–3734
- Liu Y, Zhang S (2004) Phosphorylation of 1-aminocyclopropane-1-carboxylic acid synthase by MPK6, a stress-responsive mitogen-activated protein kinase, induces ethylene biosynthesis in *Arabidopsis*. *Plant Cell* 16:3386–3399
- Liu Y, Jin H, Yang KY, Kim CY, Baker B, Zhang S (2003) Interaction between two mitogen-activated protein kinases during tobacco defense signaling. *Plant J* 34:149–160
- Liu Y, Zhang S, Klessig DF (2000b) Molecular cloning and characterization of a tobacco MAP kinase kinase that interacts with SIPK. *Mol Plant Microbe Interact* 13:118–124
- Liu Z, Xia M, Poovaiah BW (1998) Chimeric calcium/calmodulin-dependent protein kinase in tobacco: differential regulation by calmodulin isoforms. *Plant Mol Biol* 38:889–897
- Loris R, Hamelryck T, Bouckaert J, Wyns L (1998) Legume lectin structure. *Biochim Biophys Acta* 1383:9–36
- Lu C, Han MH, Guevara-Garcia A, Fedoroff NV (2002) Mitogen-activated protein kinase signaling in post-germination arrest of development by abscisic acid. *Proc Natl Acad Sci USA* 99:15812–15817
- Lu SX, Hrabak EM (2002) An *Arabidopsis* calcium-dependent protein kinase is associated with the endoplasmic reticulum. *Plant Physiol* 128:1008–1021



- Luan S (2000) Protein phosphatases: structure, regulation and function. *Adv Bot Res* 32:67–107
- Luan S (2003) Protein phosphatases in plants. *Annu Rev Plant Biol.* 54:63–92
- Luan S, Li W, Rusnak F, Assmann SM, Schreiber SL (1993) Immuno-suppressants implicate protein phosphatase regulation of potassium channels in guard cells. *Proc Natl Acad Sci USA* 90:2202–2206
- Luan S, Kudla J, Rodriguez-Concepcion M, Yalovsky S, Gruissem W (2002) Calmodulins and calcineurin B-like proteins: calcium sensors for specific signal response coupling in plants. *Plant Cell* 14(Suppl):S389–S400
- Ludwig AA, Romeis T, Jones JD (2004) CDPK-mediated signalling pathways: specificity and cross-talk. *J Exp Bot* 55:181–188
- Lukowitz W, Roeder A, Parmenter D, Somerville C (2004) A MAPKK kinase gene regulates extra-embryonic cell fate in *Arabidopsis*. *Cell* 116:109–119
- Mackintosh RW, Haycox G, Hardie DG, Cohen PTW (1990) Identification by molecular cloning of two complementary DNA sequences from the plant *Brassica napus* which are very similar to mammalian protein phosphatase-1 and protein phosphatase-2a. *FEBS Lett* 276:1–2
- MacRobbie EAC (2002) Evidence for a role for protein tyrosine phosphatase in the control of ion release from the guard cell vacuole in stomatal closure. *Proc Natl Acad Sci USA* 99:11963–11968
- Madsen EB, Madsen LH, Radutoiu S, Olbryt M, Rakwalska M, Szczyglowski K, Sato S, Kaneko T, Tabata S, Sandal N, Stougaard J (2003) A receptor kinase gene of the LysM type is involved in legume perception of rhizobial signals. *Nature* 425:637–640
- Maehama T, Taylor GS, Dixon JE (2001) PTEN and myotubularin: novel phosphoinositide phosphatases. *Annu Rev Biochem* 70:247–279
- Mansour SJ, Matten WT, Hermann AS, Candia JM, Rong S, Fukasawa K, Vande Woude GF, Ahn NG (1994) Transformation of mammalian cells by constitutively active MAP kinase kinase. *Science* 265:966–970
- MAPK Group (2002) Mitogen-activated protein kinase cascades in plants: a new nomenclature. *Trends Plant Sci* 7:301–308
- Martin GB, Brommonschenkel S, Chunwongse J, Frary A, Ganai MW, Spivey R, Wu T, Earle ED, Tanksley SD (1993) Map-based cloning of a protein kinase gene conferring disease resistance in tomato. *Science* 262:1432–1436
- Martin ML, Busconi L (2000) Membrane localization of rice calcium-dependent protein kinase (CDPK) is mediated by myristoylation and palmitoylation. *Plant J* 24:429–435
- Matsubayashi Y, Ogawa M, Morita A, Sakagami Y (2002) An LRR receptor kinase involved in perception of a peptide plant hormone, phytosulfokine. *Science* 296:1470–1472
- Matsuoka D, Nanmori T, Sato K, Fukami Y, Kikkawa U, Yasuda T (2002) Activation of AtMEK1, an *Arabidopsis* mitogen-activated protein kinase kinase, in vitro and in vivo: analysis of active mutants expressed in *E. coli* and generation of the active form in stress response in seedlings. *Plant J* 29:637–647
- Menke FL, van Pelt JA, Pieterse CM, Klessig DF (2004) Silencing of the mitogen-activated protein kinase MPK6 compromises disease resistance in *Arabidopsis*. *Plant Cell* 16:897–907
- Menke FLH, Kang H, Chen Z, Park JM, Kumar D, Klessig DF (2005) Tobacco transcription factor WRKY1 is phosphorylated by the MAP kinase SIPK and mediates HR-like cell death in tobacco. *Mol Plant Microbe Interact* 18:1027–1034
- Merlot S, Gosti F, Guerrier D, Vavasseur A, Giraudat J (2001) The ABI1 and ABI2 protein phosphatases 2C act in a negative feedback regulatory loop of the abscisic acid signaling pathway. *Plant J* 25:295–303
- Meskiene I, Bögre L, Glaser W, Balog J, Brandstötter M, Zwerger K, Ammerer G, Hirt H (1998a) MP2C, a plant protein phosphatase 2C, functions as a negative regulator of mitogen-activated protein kinase pathways in yeast and plants. *Proc Natl Acad Sci USA* 95:1938–1943
- Meskiene I, Ligterink W BL, Jonak C, Kiegerl S, Balog J, Eklöf S, Ammerer G, Hirt H (1998b) The SAM kinase pathway: an integrated circuit for stress signaling in plants. *J Plant Res* 111:339–344
- Meskiene I, Baudouin E, Schweighofer A, Liwosz A, Jonak C, Rodriguez PL, Jelinek H, Hirt H (2003) The stress-induced protein phosphatase 2C is a negative regulator of a mitogen-activated protein kinase. *J Biol Chem* 278:18945–18952
- Meszáros T, Helfer A, Hatzimasoura E, Magyar Z, Serazetdinova L, Rios G, Bardoczy V, Teige M, Koncz C, Peck S, Bogre L (2006) The *Arabidopsis* MAP kinase kinase MKK1 participates in defence responses to the bacterial elicitor flagellin. *Plant J* 48:485–498
- Mikolajczyk M, Awotunde OS, Muszynska G, Klessig DF, Dobrowolska G (2000) Osmotic stress induces rapid activation of a salicylic acid-induced protein kinase and a homolog of protein kinase ASK1 in tobacco cells. *Plant Cell* 12:165–78
- Miles GP, Samuel MA, Zhang Y, Ellis BE (2005) RNA interference-based (RNAi) suppression of AtMPK6, an *Arabidopsis* mitogen-activated protein kinase, results in hypersensitivity to ozone and misregulation of AtMPK3. *Environ Pollut* 138:230–237
- Mishra NS, Tuteja R, Tuteja N (2006) Signaling through MAP kinase networks in plants. *Arch Biochem Biophys* 452:55–68
- Mizoguchi T, Irie K, Hirayama T, Hayashida N, Yamaguchi-Shinozaki K, Matsumoto K, Shinozaki K (1996) A gene encoding a mitogen-activated protein kinase kinase kinase is induced simultaneously with genes for a mitogen-activated protein kinase and an S6 ribosomal protein kinase by touch, cold and water stress in *Arabidopsis thaliana*. *Proc Natl Acad Sci USA* 93:765–769
- Mizoguchi T, Ichimura K, Shinozaki K (1997) Environmental stress response in plants: the role of mitogen-activated protein kinases. *Trends Biotechnol* 15:15–19

- Mizoguchi T, Ichimura K, Irie K, Morris P, Giraudat J, Matsumoto K, Shinozaki K (1998) Identification of a possible MAP kinase cascade in *Arabidopsis thaliana* based on pairwise yeast two-hybrid analysis and functional complementation tests of yeast mutants. *FEBS Lett* 437:56–60
- Mockaitis K, Howell SH (2000) Auxin induces mitogenic activated protein kinase (MAPK) activation in roots of *Arabidopsis* seedlings. *Plant J* 24:785–796
- Montoya T, Nomura T, Farrar K, Kaneta T, Yokota T, Bishop GJ (2002) Cloning the tomato Curl3 gene highlights the putative dual role of the leucine-rich repeat receptor kinase tBRI1/SR160 in plant steroid hormone and peptide hormone signaling. *Plant Cell* 14:3163–3176
- Morillo SA, Tax FE (2006) Functional analysis of receptor-like kinases in monocots and dicots. *Curr Opin Plant Biol* 9:460–469
- Morris ER, Walker JC (2003) Receptor-like protein kinase: the keys to response. *Curr Opin Plant Biol* 6:339–342
- Morris PC (2001) MAP kinase signal transduction pathways in plants. *New Phytol* 151:67–89
- Munnik T, Meijer HJ (2001) Osmotic stress activates distinct lipid and MAPK signalling pathways in plants. *FEBS Lett* 498:172–178
- Munnik T, Ligterink W, Meskiene II, Calderini O, Beyerly J, Musgrave A, Hirt H (1999) Distinct osmo-sensing protein kinase pathways are involved in signalling moderate and severe hyper-osmotic stress. *Plant J* 20:381–388
- Murata Y, Pei ZM, Mori IC, Schroeder J (2001) Abscisic acid activation of plasma membrane Ca<sup>2+</sup> channels in guard cells requires cytosolic NAD(P)H and is differentially disrupted upstream and downstream of reactive oxygen species production in *abi1-1* and *abi2-1* protein phosphatase 2C mutants. *Plant Cell* 13:2513–2523
- Nagai M, Nozawa A, Koizumi N, Sano H, Hashimoto H, Sato M, Shimizu T (2003) The crystal structure of the novel calcium-binding protein AtCBL2 from *Arabidopsis thaliana*. *J Biol Chem* 278:42240–42246
- Naismith JH, Sprang SR (1998) Modularity in the TNF-receptor family. *Trends Biochem Sci* 23:74–79
- Nakagami H, Kiegerl S, Hirt H (2004) OMTK1, a novel MAPKKK, channels oxidative stress signaling through direct MAPK interaction. *J Biol Chem* 279:26959–26966
- Nakagami H, Pitzschke A, Hirt H (2005) Emerging MAP kinase pathways in plant stress signaling. *Trends Plant Sci* 7:339–346
- Nakagami H, Soukupova H, Schikora A, Zarsky V, Hirt H (2006) A mitogen-activated protein kinase kinase kinase mediates reactive oxygen species homeostasis in *Arabidopsis*. *J Biol Chem* 281:38697–38704
- Nakamura A, Fujioka S, Sunohara H, Kamiya N, Hong Z, Inukai Y, Miura K, Takatsuto S, Yoshida S, Ueguchi-Tanaka M, Hasegawa Y, Kitano H, Matsuoka M (2006) The role of OsBRI1 and its homologous genes, OsBRL1 and OsBRL3, in rice. *Plant Physiol* 140:580–590
- Nam KH, Li J (2002) BRI1/BAK1, a receptor kinase pair mediating brassinosteroid signaling. *Cell* 110:203–212
- Narvaez-Vasquez J, Ryan CA (2002) The systemin precursor gene regulates both defensive and developmental genes in *Solanum tuberosum*. *Proc Natl Acad Sci USA* 99:15818–15821
- Nirmala J, Brueggeman R, Maier C, Clay C, Rostoks N, Kannangara CG, von Wettstein D, Steffenson BJ, Kleinhofs A (2006) Sub-cellular localization and functions of the barley stem rust resistance receptor-like serine/threonine-specific protein kinase Rpg1. *Proc Natl Acad Sci USA* 103:7518–7523
- Nishihama R, Ishikawa M, Araki S, Soyano T, Asada T, Machida Y (2001) The NPK1 mitogen-activated protein kinase kinase kinase is a regulator of cell-plate formation in plant cytokinesis. *Genes Dev* 15:352–363
- Nishihama R, Soyano T, Ishikawa M, Araki S, Tanaka H, Asada T, Irie K, Ito M, Terada M, Banno H, Yamazaki Y, Machida Y (2002) Expansion of the cell plate in plant cytokinesis requires a kinesin-like protein/MAPKKK complex. *Cell* 109:87–99
- Nishimura R, Hayashi M, Wu GJ, Kouchi H, Imaizumi-Anraku H, Murakami Y, Kawasaki S, Akao S, Ohmori M, Nagasawa M, Harada K, Kawaguchi M (2002) HAR1 mediates systemic regulation of symbiotic organ development. *Nature* 420:426–429
- Nomura T, Bishop GJ, Kaneta T, Reid JB, Chory J, Yokota T (2003) The LKA gene is a brassinosteroid insensitive 1 homolog of pea. *Plant J* 36:291–300
- Novikova GV, Moshkov IE, Smith AR, Hall MA (2000) The effect of ethylene on MAPKase-like activity in *Arabidopsis thaliana*. *FEBS Lett* 474:29–32
- Nuhse TS, Peck SC, Hirt H, Boller T (2000) Microbial elicitors induce activation and dual phosphorylation of the *Arabidopsis thaliana* MAPK 6. *J Biol Chem* 275:7521–7526
- Nürnberg T, Kemmerling B (2006) Receptor protein kinases-pattern recognition receptors in plant immunity. *Trends Plant Sci* 11:519–522
- Oh MH, Ray WK, Huber SC, Asara JM, Gage DA, Clouse SD (2000) Recombinant brassinosteroid insensitive 1 receptor-like kinase autophosphorylates on serine and threonine residues and phosphorylates a conserved peptide motif in vitro. *Plant Physiol* 124:751–766
- Ok SH, Jeong HJ, Bae JM, Shin JS, Luan S, Kim KN (2005) Novel CIPK1-associated proteins in *Arabidopsis* contain an evolutionarily conserved C-terminal region that mediates nuclear localization. *Plant Physiol* 139:138–150
- Osakabe Y, Maruyama K, Seki M, Satou M, Shinozaki K, Yamaguchi-Shinozaki K (2005) Leucine-rich repeat receptor-like kinase 1 is a key membrane-bound regulator of abscisic acid early signaling in *Arabidopsis*. *Plant Cell* 17:1105–1119
- Ouaked F, Rozhon W, Lecourieux D, Hirt H (2003) A MAPK pathway mediates ethylene signaling in plants. *EMBO J* 22:1282–1288
- Overmyer K, Tuominen H, Kettunen R, Betz C, Langebartels C, Sandermann H Jr, Kangasjärvi J. (2000) Ozone-sensitive arabidopsis *red1* mutant reveals opposite

- roles for ethylene and jasmonate signaling pathways in regulating superoxide-dependent cell death. *Plant Cell* 22:1849–1862
- Overmyer K, Brosche M, Pellinen R, Kuittinen T, Tuominen H, Ahlfors R, Keinanen M, Saarma M, Scheel D, Kangasjarvi J (2005) Ozone-induced programmed cell death in the *Arabidopsis* radical-induced cell death1 mutant. *Plant Physiol* 137:1092–1104
- Pagnussat GC, Lanteri ML, Lombardo MC, Lamattina L (2004) Nitric oxide mediates the indole acetic acid induction activation of a mitogen-activated protein kinase cascade involved in adventitious root development. *Plant Physiol* 135:279–286
- Pan CH, Lee EA, Chae YA, Kim SI (1999) Purification of chitinolytic protein from *Rehmannia glutinosa* showing N-terminal amino acid sequence similarity to thaumatin-like proteins. *Biosci Biotechnol Biochem* 63:1138–1140
- Pandey GK, Cheong YH, Kim KN, Grant JJ, Li L, Hung W, D'Angelo C, Weint S, Kudla J, Luan S (2004) The calcium sensor calcineurin B-like 9 modulates abscisic acid sensitivity and biosynthesis in *Arabidopsis*. *Plant Cell* 16:1912–1924
- Pardo JM, Reddy MP, Yang S, Maggio A, Huh GH, Matsumoto T, Coca MA, Paino-D'Urzo M, Koiwa H, Yun DJ, Watad AA, Bressan RA, Hasegawa PM (1998) Stress signaling through Ca<sup>2+</sup>/calmodulin-dependent protein phosphatase calcineurin which mediates salt adaptation in plants. *Proc Natl Acad Sci USA* 95:9681–9686
- Patharkar OR, Cushman JC (2000) A stress-induced calcium-dependent protein kinase from *Mesembryanthemum crystallinum* phosphorylates a two-component pseudo-response regulator. *Plant J* 24:679–691
- Patil S, Takezawa D, Poovaiah BW (1995) Chimeric plant calcium/calmodulin-dependent protein kinase gene with a neural visinin-like calcium-binding domain. *Proc Natl Acad Sci USA* 92:4897–4901
- Pawson T (2002) Regulation and targets of receptor tyrosine kinases. *Eur J Cancer* 38:S3–S10
- Peck SC (2003) Early phosphorylation events in biotic stress. *Curr Opin Plant Biol* 6(4):334–333
- Pei ZM, Murata Y BG, Thomine S, Klusener B, Allen GJ, Grill E, Schroeder JI (2000) Calcium channels activated by hydrogen peroxide mediate abscisic acid signalling in guard cells. *Nature* 406:731–734
- Perry RL, Parker MH, Rudnicki MA (2001) Activated MEK1 binds the nuclear MyoD transcriptional complex to repress transactivation. *Mol Cell* 8:291–301
- Petersen M, Brodersen P, Naested H, Andreasson E, Lindhart U, Johansen B, Nielsen HB, Lacy M, Austin MJ, Parker JE, Sharma SB, Klessig DF, Martienssen R, Mattsson O, Jensen AB, Mundy J (2000) *Arabidopsis* MAP kinase 4 negatively regulates systemic acquired resistance. *Cell* 103:1111–1120
- Pical C, Fredlund KM, Petit PX, Sommarin M, Moller IM (1993) The outer membrane of plant mitochondria contains a calcium-dependent protein kinase and multiple phosphoproteins. *FEBS Lett* 336:347–351
- Pirck M, Pay A, Heberle-Bors E, Hirt H (1993) Isolation and characterization of a phosphoprotein phosphatase type 2A gene from alfalfa. *Mol Gen Genet* 240:126–131
- Pitzschke A, Hirt H (2006) Mitogen-activated protein kinases and reactive oxygen species signaling in plants. *Plant Physiol* 141:351–356
- Qiu QS, Guo Y, Dietrich MA, Schumaker KS, Zhu JK (2002) Regulation of SOS1, a plasma membrane Na<sup>+</sup>/H<sup>+</sup> exchanger in *Arabidopsis thaliana*, by SOS2 and SOS3. *Proc Natl Acad Sci USA* 99:8436–8441
- Quan R, Lin H, Mendoza I, Zhang Y, Cao W, Yang Y, Shang M, Chen S, Pardo JM, Guo Y (2007) SCABP8/CBL10, a putative calcium sensor, interacts with the protein kinase SOS2 to protect *Arabidopsis* shoots from salt stress. *Plant Cell* 19:1415–1431
- Quettier AL, Bertrand C, Habricot Y, Miginiac E, Agnes C, Jeannette E, Maldiney R (2006) The phs1–3 mutation in a putative dual-specificity protein tyrosine phosphatase gene provokes hypersensitive responses to abscisic acid in *Arabidopsis thaliana*. *Plant J* 47:711–719
- Quimby BB, Wilson CA, Corbett AH (2000) The interaction between Ran and NTF2 is required for cell cycle progression. *Mol Biol Cell* 11:2617–2629
- Quintero FJ, Ohta M, Shi H, Zhu JK, Pardo JM (2002) Reconstitution in yeast of the *Arabidopsis* SOS signaling pathway for Na<sup>+</sup> homeostasis. *Proc Natl Acad Sci USA* 99:9061–9066
- Radutoiu S, Madsen LH, Madsen EB, Felle HH, Umehara Y, Gronlund M, Sato S, Nakamura Y, Tabata S, Sandal N, Stougaard J (2003) Plant recognition of symbiotic bacteria requires two LysM receptor-like kinases. *Nature* 425:585–592
- Rashotte AM, DeLong A, Muday GK (2001) Genetic and chemical reductions in protein phosphatase activity alter auxin transport, gravity response and lateral root growth. *Plant Cell* 13:1683–1697
- Ren D, Yang H, Zhang S (2002) Cell death mediated by MAPK is associated with hydrogen peroxide production in *Arabidopsis*. *J Biol Chem* 277:559–565
- Rentel MC, Lecourieux D, Ouaked F, Usher SL, Petersen L, Okamoto H, Knight H, Peck SC, Grierson CS, Hirt H, Knight MR (2004) OX11 kinase is necessary for oxidative burst-mediated signalling in *Arabidopsis*. *Nature* 427:858–861
- Rodriguez Milla MA, Uno Y, Chang IF, Townsend J, Maher EA, Quilici D, Cushman JC (2006) A novel yeast two-hybrid approach to identify CDPK substrates: characterization of the interaction between AtCPK11 and AtDi19, a nuclear zinc finger protein. *FEBS Lett* 580:904–911
- Rodriguez PL (1998) Protein phosphatase 2C (PP2C) function in higher plants. *Plant Mol Biol* 38:919–927
- Rodriguez PL, Leube MP, Grill E (1998) Molecular cloning in *Arabidopsis thaliana* of a new protein phosphatase 2C (PP2C) with homology to ABI1 and ABI2. *Plant Mol Biol* 38:879–883
- Romeis T (2001) Protein kinases in the plant defence response. *Curr Opin Plant Biol* 4:407–414

- Rudd JJ, Franklin-Tong VE (2001) Unravelling response-specificity in Ca<sup>2+</sup> signalling pathways in plant cells. *New Phytol* 151:7–33
- Rundle SJ, Hartung AJ, Corum JW, O'Neill M III (1995) Characterization of a cDNA encoding the 55 kDa B regulatory subunit of *Arabidopsis* protein phosphatase 2A. *Plant Mol Biol* 28:257–266
- Saez A, Apostolova N, Gonzalez-Guzman M, Gonzalez-Garcia MP, Nicolas C, Lorenzo O, Rodriguez PL (2004) Gain-of-function and loss-of-function phenotypes of the protein phosphatase 2C HAB1 reveals its role as a negative regulator of abscisic acid signaling. *Plant J* 37:354–369
- Saez A, Robert N, Maktabi MH, Schroeder JI, Serrano R, Rodriguez PL (2006) Enhancement of abscisic acid sensitivity and reduction of water consumption in *Arabidopsis* by combined inactivation of the protein phosphatases type 2C ABI1 and HAB1. *Plant Physiol* 141:1389–1399
- Sai J, Johnson CH (2002) Dark-stimulated calcium ion fluxes in the chloroplast stroma and cytosol. *Plant Cell* 14:1279–1291
- Samuel MA, Ellis BE (2002) Double jeopardy: both over-expression and suppression of a redox-activated plant mitogen-activated protein kinase render tobacco plants ozone sensitive. *Plant Cell* 14:2059–2069
- Samuel MA, Miles GP, Ellis BE (2000) Ozone treatment rapidly activates MAP Kinase signalling in plants. *Plant J* 22:367–376
- Sanders D, Pelloux J, Brownlee C, Harper JF (2002) Calcium at the crossroads of signaling. *Plant Cell* 14(Suppl):S401–S417
- Schaffer R, Landgraf J, Accerbi M, Simon V, Larson M, Wisman E (2001) Microarray analysis of diurnal and circadian-regulated genes in *Arabidopsis*. *Plant Cell* 13:113–123
- Scheer JM, Ryan CA (2002) From the cover: the systemin receptor SR160 from *Lycopersicon peruvianum* is a member of the LRR receptor kinase family. *Proc Natl Acad Sci USA* 99:9585–9590
- Schillace RV, Scott JD (1999) Organization of kinases, phosphatases and receptor signaling complexes. *J Clin Invest* 103:761–765
- Schoenbeck MA, Samac DA, Fedorova M, Gregerson RG, Gantt JS, Vance CP (1999) The alfalfa (*Medicago sativa*) TDY1 gene encodes a mitogen-activated protein kinase homolog. *Mol Plant Microbe Interact* 12:882–893
- Schopfer C, Nasrallah M, Nasrallah J (1999) The male determinant of self-incompatibility in *Brassica*. *Science* 286:1697–1700
- Schroeder JI, Kwak JM, Allen GJ (2001) Guard cell abscisic acid signalling and engineering drought hardiness in plants. *Nature* 410:327–330
- Schweighofer A, Hirt H, Meskiene I (2004) Plant PP2C phosphatases: emerging functions in stress signaling. *Trends Plant Sci* 9:236–243
- Scofield SR, Tobias CM, Rathjen JP, Chang JH, Lavelle DT, Michelmore RW, Staskawicz BJ (1996) Molecular basis of gene-for-gene specificity in bacterial speck disease of tomato. *Science* 274:2063–2065
- Searle IR, Men AE, Laniya TS, Buzas DM, Iturbe-Ormaetxe I, Carroll BJ, Gresshoff PM (2003) Long-distance signaling in nodulation directed by a CLAVATA1-like receptor kinase. *Science* 299:109–112
- Seo S, Okamoto M, Seto H, Ishizuka K, Sano H, Ohashi Y (1995) Tobacco MAP kinase: a possible mediator in wound signal transduction pathways. *Science* 270:1988–1992
- Seo S, Sano H, Ohashi Y (1999) Jasmonate-based wound signal transduction requires activation of WIPK, a tobacco mitogen-activated protein kinase. *Plant Cell* 11:289–298
- Shah K, Russinova E, Gadella TW, Willemse J, De Vries SC (2002) The *Arabidopsis* kinase-associated protein phosphatase controls internalization of the somatic embryogenesis receptor kinase 1. *Genes Dev* 16:1707–1720
- Sharon H, Lis H (1990) Legume lectin: a large family of homologous proteins. *FASEB J* 4:3198–3208
- Sheen J (1998) Mutational analysis of protein phosphatase 2C involved in abscisic acid signal transduction in higher plants. *Proc Natl Acad Sci USA* 95:975–980
- Shi J, Kim KN, Ritz O, Albrecht V, Gupta R, Harter K, Luan S, Kudla J (1999) Novel protein kinases associated with calcineurin B-like calcium sensors in *Arabidopsis*. *Plant Cell* 11:2393–2405
- Shiozaki K, Russell P (1995) Cell-cycle control linked to extracellular environment by MAP kinase pathway in fission yeast. *Nature* 378:739–743
- Shiu SH, Bleecker AB (2001) Plant receptor-like kinase gene family: diversity, function and signaling. *Sci STKE*, RE22
- Shiu SH, Karlowski WM, Pan R, Tzeng YH, Mayer KFX, Li WH (2004) Comparative analysis of the receptor-like kinase family in *Arabidopsis* and rice. *Plant Cell* 16:1220–1234
- Slabas AR, Fordham-Skelton AP, Fletcher D, Martinez-Rivas JM, Swinhoe R CRR, Evans IM (1994) Characterisation of cDNA and genomic clones encoding homologues of the 65 kDa regulatory sub-unit of protein phosphatase 2A in *Arabidopsis thaliana*. *Plant Mol Biol* 26:1125–1138
- Smith RD, Walker JC (1993) Expression of multiple type 1 phosphoprotein phosphatases in *Arabidopsis thaliana*. *Plant Mol Biol* 21:307–316
- Smith RD, Walker JC (1996) Plant protein phosphatases. *Annu Rev Plant Physiol Plant Mol Biol* 47:101–125
- Sokolov LN, Dominguez-Solis JR, Allary AL, Buchanan BB, Luan S (2006) A redox-regulated chloroplast protein phosphatase binds to starch diurnally and functions in its accumulation. *Proc Natl Acad Sci USA* 103, 9732–9737
- Song WY, Wang GL, Chen LL, Kim HS, Pi LY, Holsten T, Gardner J, Wang B, Zhai WX, Zhu LH, Fauquet C, Ronald P (1995) A receptor kinase-like protein encoded by the rice disease resistance gene, Xa21. *Science* 270:1804–1806
- Soyano T, Nishihama R, Morikiyo K, Ishikawa M, Machida Y (2003) NQK1/NtMEK1 is a MAPKK that acts in the NPK1



- MAPKKK-mediated MAPK cascade and is required for plant cytokinesis. *Genes Dev* 17:1055–1067
- Stein JC, Howlett B, Boyes DC, Nasrallah ME, Nasrallah JB (1991) Molecular cloning of a putative receptor protein kinase gene encoded at the self-incompatibility locus of *Brassica oleracea*. *Proc Natl Acad Sci USA* 88:8816–8820
- Stone JM, Trotochaud AE, Walker JC, Clark SE (1998) Control of meristem development by CLAVATA1 receptor kinase and kinase-associated protein phosphatase interactions. *Plant Physiol* 117:1217–1225
- Stone RL, Dixon JE (1994) Protein tyrosine phosphatases. *J Biol Chem* 269:31323–31326
- Stracke S, Kistner C, Yoshida S, Mulder L, Sato S, Kaneko T, Tabata S, Sandal N, Stougaard J, Szczyglowski K, Parniske M (2002) A plant receptor-like kinase required for both bacterial and fungal symbiosis. *Nature* 417:959–962
- Suarez-Rodriguez MC, Adams-Phillips L, Liu Y, Wang H, Su SH, Jester PJ, Zhang S, Bent AF, Krysan PJ (2007) MEKK1 is required for flg22-induced MPK4 activation in *Arabidopsis* plants. *Plant Physiol* 143:661–669
- Suh MC, Cho HS, Kim YS, Liu JR, Lee HS (1998) Multiple genes encoding serine/threonine protein phosphatases and their differential expression in *Nicotiana glauca*. *Plant Mol Biol* 36:315–322
- Sun Y, Fokar M, Asami T, Yoshida S, Allen R (2004) Characterization of the brassinosteroid insensitive 1 genes of cotton. *Plant Mol Biol* 54:221–232
- Suzuki K, Shinshi H (1995) Transient activation and tyrosine phosphorylation of a protein kinase in tobacco cells treated with a fungal elicitor. *Plant Cell* 7:639–647
- Swiderski MR, Innes RW (2001) The *Arabidopsis* PBS1 resistance gene encodes a member of a novel protein kinase sub-family. *Plant J* 26:101–112
- Symons GM, Davies C, Shavrukov Y, Dry IB, Reid JB, Thomas MR (2006) Grapes on steroids - brassinosteroids are involved in grape berry ripening. *Plant Physiol* 140:150–158
- Takahashi Y, Berberich T, Yamashita K, Uehara Y, Miyazaki A, Kusano T (2004) Identification of tobacco HIN1 and two closely related genes as spermine-responsive genes and their differential expression during the Tobacco mosaic virus-induced hypersensitive response and during leaf- and flower-senescence. *Plant Mol Biol* 54:613–622.
- Takemiya A, Kinoshita T, Asanuma M, Shimazaki K (2006) Protein phosphatase 1 positively regulates stomatal opening in response to blue light in *Vicia faba*. *Proc Natl Acad Sci USA* 103:13549–13554
- Tang D, Innes RW (2002) Over-expression of a kinase-deficient form of the EDR1 gene enhances powdery mildew resistance and ethylene-induced senescence in *Arabidopsis*. *Plant J* 32:975–983
- Tang X, Frederick RD, Zhou J, Halterman DA, Jia Y, Martin GB (1996) Initiation of plant disease resistance by physical interaction of avrPto and Pto kinase. *Science* 274:2060–2063
- Teige M, Scheickl E, Eulgem T, Doczi R, Ichimura K, Shinozaki K, Dangl JL, Hirt H (2004) The MKK2 pathway mediates cold and salt stress signaling in *Arabidopsis*. *Mol Cell* 15:141–152
- Tena G, Asai T, Chiu WL, Sheen J (2001) Plant mitogen-activated protein kinase signaling cascades. *Curr Opin Plant Biol* 4:392–400
- Tichtinsky G, Vanoosthuysse V, Cock JM, Gaude T (2003) Making inroads into plant receptor kinase signaling pathways. *Trends Plant Sci* 8:231–237
- Tonks NK, Neel BG (1996) From form to function: signaling by protein tyrosine phosphatases. *Cell* 87:365–368
- Tonks NK, Charbonneau H, Diltz CD, Fischer EH, Walsh KA (1988) Demonstration that the leukocyte common antigen CD 45 is a protein tyrosine phosphatase. *Biochemistry* 27:8695–8701
- Torii KU, Mitsukawa N, Oosumi T, Matsuura Y, Yokoyama R, Whittier RF, Komeda Y (1996) The *Arabidopsis* ERECTA gene encodes a putative receptor protein kinase with extracellular leucine-rich repeats. *Plant Cell* 8:735–746
- Trotochaud AE, Hao T, Guang W, Yang Z, Clark SE (1999) The CLAVATA1 receptor-like kinase requires CLAVATA3 for its assembly into a signaling complex that includes KAPP and a Rho-related protein. *Plant Cell* 11:393–405
- Trotochaud AE, Jeong S, Clark SE (2000) CLAVATA3, a multimeric ligand for the CLAVATA1 receptor-kinase. *Science* 289:613–617
- Ulm R, Revenkova E, di Sansebastiano GP, Bechtold N, Paszkowski J (2001) Mitogen-activated protein kinase phosphatase is required for genotoxic stress relief in *Arabidopsis*. *Genes Dev* 15:699–709
- Vert G, Chory J (2006) Downstream nuclear events in brassinosteroid signalling. *Nature* 441:96–100
- Vinocur B, Altman A (2005) Recent advances in engineering plant tolerance to abiotic stress: achievements and limitations. *Curr Opin Biotechnol* 16(2):123–132
- Vranova E, Tähtiharju S, Sriprang R, Willekens H, Heino P, Palva ET, Inzé D, Van Camp W (2001) The AKT3 potassium channel protein interacts with the AtPP2CA protein phosphatase 2C. *J Exp Bot* 52:181–182
- Wagner TA, Kohorn BD (2001) Wall-associated kinases are expressed throughout plant development and are required for cell expansion. *Plant Cell* 13:303–318
- Walker JC (1994) Structure and function of the receptor-like protein kinases of higher plants. *Plant Mol Biol* 26:1599–1609
- Walker JC, Zhang R (1990) Relationship of a putative receptor protein kinase from maize to the S-locus glycoproteins of *Brassica*. *Nature* 345:743–746
- Wang W, Vinocur B, Altman A (2003) Plant responses to drought, salinity and extreme temperatures: towards genetic engineering for stress tolerance. *Planta* 218(1):1–14
- Wang X, Zafian P, Choudhary M, Lawton M (1996) The PR5K receptor protein kinase from *Arabidopsis thaliana* is structurally related to a family of plant defense proteins. *Proc Natl Acad Sci USA* 93:2598–2602
- Wang X, Li X, Meisenhelder J, Hunter T, Yoshida S, Asami T, Chory J (2005) Autoregulation and homodimerization

- are involved in the activation of the plant steroid receptor BRI1. *Dev Cell* 8:855–865
- Wang YS, Pi LY, Chen X, Chakrabarty PK, Jiang J, De Leon AL, Liu GZ, Li L, Benny U, Oard J, Ronald PC, Song WY (2006) Rice XA21 binding protein 3 is an ubiquitin ligase required for full Xa21-mediated disease resistance. *Plant Cell* 18:3635–3646
- Wang ZY, Seto H, Fujioka S, Yoshida S, Chory J (2001) BRI1 is a critical component of a plasma-membrane receptor for plant steroids. *Nature* 410:38–383
- Wang ZY, Nakano T, Gendron J, He J, Chen M, Vafeados D, Yang Y, Fujioka S, Yoshida S, Asami T, Chory J (2002) Nuclear-localized BZR1 mediates brassinosteroid-induced growth and feedback suppression of brassinosteroid biosynthesis. *Dev Cell* 2:505–513
- Ward JM, Pei ZM, Schroeder JI (1995) Roles of ion channels in initiation of signal transduction in higher plants. *Plant Cell* 7:833–844
- Watillon B, Kettmann R, Boxus P, Burny A (1993) A calcium/calmodulin-binding serine/threonine protein kinase homologous to the mammalian type II calcium/calmodulin-dependent protein kinase is expressed in plant cells. *Plant Physiol* 101:1381–1384
- Watillon B, Kettmann R, Boxus P, Burny A (1995) Structure of a calmodulin-binding protein kinase gene from apple. *Plant Physiol* 108:847–848
- Weis WI, Drickamer K (1996) Structural basis of lectin-carbohydrate recognition. *Annu Rev Biochem* 65:441–473
- White RJ, Davis M, Esmon CA, Myrick TL, Cochran DS, Rundle SJ (2002) Functional analysis of the B0 subunit of *Arabidopsis* protein phosphatase type 2A. *Plant Sci* 162:201–209
- White PJ, Broadley MR (2003) Calcium in plants. *Ann Bot (Lond)* 92:487–511
- Williams RW, Wilson JM, Meyerowitz EM (1997) A possible role for kinase-associated protein phosphatase in the *Arabidopsis* CLAVATA1 signaling pathway. *Proc Natl Acad Sci USA* 94:10467–10472
- Wu Y, Sanchez JP, Lopez-Molina L, Himmelbach A, Grill E, Chua NH (2003) The *abi1-1* mutation blocks ABA signaling downstream of cADPR action. *Plant J* 34:307–315
- Wurgler-Murphy SM, Saito H (1997) Two-component signal transducers and MAPK cascades. *Trends Biochem Sci* 22:172–176
- Xiong L, Yang Y (2003) Disease resistance and abiotic stress tolerance in rice are inversely modulated by an abscisic acid-inducible mitogen-activated protein kinase. *Plant Cell* 15:745–759
- Xiong L, Schumaker KS, Zhu JK (2002) Cell signaling during cold, drought, and salt stress. *Plant Cell* 14(Suppl), S165–S183
- Xu Q, Fu HH, Gupta R, Luan S (1998) Molecular characterization of a tyrosine-specific protein phosphatase encoded by a stress-responsive gene in *Arabidopsis*. *Plant Cell* 10:849–857
- Xu J, Li HD, Chen LQ, Wang Y, Liu LL, He L, Wu WH (2006) A protein kinase, interacting with two calcineurin B-like proteins, regulates K<sup>+</sup> transporter AKT1 in *Arabidopsis*. *Cell* 125:1347–1360
- Yamamoto C, Kuchimura K, Kobayashi A, Katou S, Kawakita K, Jones JDG, Doke N, Yoshioka H (2006) Rewiring mitogen-activated protein kinase cascade by positive feedback confers potato blight resistance. *Plant Physiol* 140:681–692
- Yamamoto C, Ihara Y, Wu X, Noguchi T, Fujioka S, Takatsuto S, Ashikari M, Kitano H, Matsuoka M (2000) Loss of function of rice brassinosteroid insensitive1 homolog prevents internode elongation and bending of the lamina joint. *Plant Cell* 12:1591–1606
- Yang KY, Liu Y, Zhang S (2001) Activation of a mitogen-activated protein kinase pathway is involved in disease resistance in tobacco. *Proc Natl Acad Sci USA* 98:741–746
- Yang Y, Shah J, Klessig DF (1997) Signal perception and transduction in plant defense responses. *Genes Dev* 11:1621–1639
- Yap Y, Kodama Y, Waller F, Chung KM, Ueda H, Nakamura K, Oldsen M, Yoda H, Yamaguchi Y, Sano H (2005) Activation of a novel transcription factor through phosphorylation by WIPK, a wound-induced mitogen-activated protein kinase in tobacco plants. *Plant Physiol* 139:127–137
- Yin Y, Wang ZY, Mora-Garcia S, Li J, Yoshida S, Asami T, Chory J (2002) BES1 accumulates in the nucleus in response to brassinosteroids to regulate gene expression and promote stem elongation. *Cell* 109:181–191
- Yoo BC, Lee JY, Lucas WJ (2002) Analysis of the complexity of protein kinases within the phloem sieve tube system – characterization of *Cucurbita maxima* calmodulin-like domain protein kinase 1. *J Biol Chem* 277:15325–15332
- Yoshida T, Nishimura N, Kitahata N, Kuromori T, Ito T, Asami T, Shinozaki K, Hirayama T (2006) ABA-hypersensitive germination3 encodes a protein phosphatase 2C (AtPP2CA) that strongly regulates abscisic acid signaling during germination among *Arabidopsis* protein-phosphatase 2Cs. *Plant Physiol* 140:115–126
- Yoshioka H, Numata N, Nakajima K, Katou S, Kawakita K, Rowland O, Jones JDG, Doke N (2003) *Nicotiana benthamiana* gp91phox homologs NbrbohA and NbrbohB participate in H<sub>2</sub>O<sub>2</sub> accumulation and resistance to *Phytophthora infestans*. *Plant Cell* 15:706–718
- Yu LP, Simon EJ, Trotochaud AE, Clark SE (2000) POLTERGEIST functions to regulate meristem development downstream of the CLAVATA loci. *Development* 127:1661–1670
- Yu LP, Miller AK, Clark SE (2003) POLTERGEIST encodes a protein phosphatase 2C that regulates CLAVATA pathways controlling stem cell identity at *Arabidopsis* shoots and flower meristems. *Curr Biol* 13:179–188

- Yuasa T, Ichimura K, Mizoguchi T, Shinozaki K (2001) Oxidative stress activates AtMPK6, an *Arabidopsis* homologue of MAP kinase. *Plant Cell Physiol* 42:1012–1016
- Yu RM, Wong MM, Jack RW, Kong RY. (2005) Structure, evolution and expression of a second subfamily of protein phosphatase 2A catalytic subunit genes in the rice plant (*Oryza sativa* L.). *Planta* 222:757–768
- Zhan XL, Deschenes RJ, Guan KL (1997) Differential regulation of FUS3MAP kinase by tyrosine-specific phosphatases PTP2-PTP3 and dualspecificity phosphatase MSG5 in *Saccharomyces cerevisiae*. *Genes Dev* 11:1690–1702
- Zhang K, Letham DS, John PCL (1996) Cytokinin controls the cell cycle at mitosis by stimulating the tyrosine dephosphorylation and activation of p34-cdc2-like H1 histone kinase. *Planta* 200:2–12
- Zhang L, Lu YT (2003) Calmodulin-binding protein kinases in plants. *Trends Plant Sci* 8:123–127
- Zhang L, Liu BF, Liang S, Jones RL, Lu YT (2002) Molecular and biochemical characterization of a calcium/calmodulin-binding protein kinase from rice. *Biochem J* 368:145–157
- Zhang S, Klessig DF (1998) Resistance gene N-mediated de novo synthesis and activation of a tobacco mitogen-activated protein kinase by tobacco mosaic virus infection. *Proc Natl Acad Sci USA* 95:7433–7438
- Zhang S, Klessig DF (2001) MAPK cascades in plant defense signaling. *Trends Plant Sci* 6:520–527
- Zhang S, Liu Y (2001) Activation of salicylic acid-induced protein kinase, a mitogen-activated protein kinase, induces multiple defense responses in tobacco. *Plant Cell* 13:1877–1889
- Zhang S, Liu Y, Klessig DF (2000) Multiple levels of tobacco WIPK activation during the induction of cell death by fungal elicitors. *Plant J* 23:339–347
- Zhang S, Chen C, Li L, Meng L, Singh J, Jiang N, Deng XW, He ZH, Lemaux PG (2005a) Evolutionary expansion, gene structure and expression of the rice wall-associated kinase gene family. *Plant Physiol* 139:1107–1124
- Zhang T, Wang Q, Chen X, Tian C, Wang X, Xing T, Li Y, Wang Y (2005b) Cloning and biochemical properties of CDPK gene OsCDPK14 from rice. *J Plant Physiol* 162:1149–1159
- Zhang T, Liu Y, Yang T, Zhang L, Xu S, Xue L, An L (2006) Diverse signals converge at MAPK cascades in plant. *Plant Physiol Biochem* 44:274–283
- Zhang W, Qin C, Zhao J, Wang X (2004) Phospholipase D alpha 1-derived phosphatidic acid interacts with ABI1 phosphatase 2C and regulates abscisic acid signaling. *Proc Natl Acad Sci USA* 101(25):9508–9513
- Zhao DZ, Wang GF, Speal B, Ma H (2002) The excess microsporocytes1 gene encodes a putative leucine-rich repeat receptor protein kinase that controls somatic and reproductive cell fates in the *Arabidopsis* anther. *Genes Dev* 16:2021–2031
- Zhou A, Wang H, Walker JC, Li J (2004) BRL1, a leucine-rich repeat receptor-like protein kinase, is functionally redundant with BRI1 in regulating *Arabidopsis* brassinosteroid signaling. *Plant J* 40:399–409
- Zhou J, Loh YT, Bressan RA, Martin GB (1995) The tomato gene Pti1 encodes a serine/threonine kinase that is phosphorylated by Pto and is involved in the hypersensitive response. *Cell* 83:925–935
- Zhou J, Tang X, Martin GB (1997) The Pto kinase conferring resistance to tomato bacterial speck disease interacts with proteins that bind a cis element of pathogenesis-related genes. *EMBO J* 16:3207–3218
- Zhu JK (2002) Salt and drought stress signal transduction in plants. *Annu Rev Plant Biol* 53:247–273
- Zhu JK, Liu J, Xiong L (1998) Genetic analysis of salt tolerance in *Arabidopsis* - evidence for a critical role of potassium nutrition. *Plant Cell* 10:1181–1191
- Zimmerlin A, Jupe SC, Bolwell GP (1995) Molecular cloning of the cDNA encoding a stress-inducible protein phosphatase1 (PP1) catalytic subunit from French bean (*Phaseolus vulgaris* L.). *Plant Mol Biol* 28:363–368
- Zipfel C, Kunze G, Chinchilla D, Caniard A, Jones JDG, Boller T, Felix G (2006) Perception of the bacterial PAMP EF-Tu by the receptor EFR restricts *Agrobacterium*-mediated transformation. *Cell* 125:749–760
- Zwinger K, Hirt H (2001) Recent advances in plant MAP kinase signalling. *Biol Chem* 382:1123–1131

## Nitrogen Source Influences Root to Shoot Signaling Under Drought

Jason Q.D. Goodger

*School of Botany, The University of Melbourne, Victoria, Australia, 3010*

Daniel P. Schachtman\*

*Donald Danforth Plant Science Center, 975 N,  
Warson Rd, St. Louis, MO 63132, USA*

Summary .....	165
I Introduction .....	166
II Nitrogen Source and Availability Influences Signaling Under Drought.....	166
A Ammonium and Nitrate Nutrition Methods.....	168
B Ammonium and Nitrate Fertilization Alters Response to Drought .....	168
III Charge Balance in the Xylem Accounts for Changes Induced by Nutrition and Drought .....	169
IV Ammonium and Nitrate Grown Plants: Changes in Xylem Sap Composition.....	170
A Ammonium Nutrition.....	170
B Nitrate Nutrition.....	171
V Conclusions .....	172
Acknowledgements .....	172
References .....	172

### Summary

The translocation of chemical signals within plants is important for plant adaptation to stress, especially abiotic stresses such as drought. As soils become dry, root-sourced signals are transported via the xylem to leaves. Nitrate is thought to play a role in modifying root to shoot signaling under drought. We present new data on experiments that used nitrate and ammonium nutrition to modify xylem sap pH. The changes in xylem sap composition in maize grown under either nitrate or ammonium nutrition were comprehensively measured. Our analysis of these results suggests a new hypothesis in which many of the changes in xylem sap composition are due to charge balance needing to be achieved when different types of solutes are transported into the xylem. These results provide new insight into some of the factors that influence root to shoot signaling under drought.

**Keywords** ABA flux • charge balance • root to shoot signaling • transpiration • water use efficiency

---

\* Author for Correspondence, e-mail: dschachtman@danforthcenter.org



## I Introduction

Plant roots are highly specialized organs that have numerous functions, most of which facilitate a direct interaction between a plant and its environment via the rhizosphere. The most obvious and well-studied functions of roots are anchorage and the acquisition of water and minerals from the soil. The functional relationship between plant roots and the rhizosphere, however, is much more complex; a fact that has often been underappreciated by plant scientists. This complexity is largely due to the highly heterogeneous and dynamic nature of the soil environment in which plant roots function. Consequently, roots have evolved specialized functions to respond to many different environmental stresses, thus enabling them to maintain the supply of required nutrients and water under many conditions. Soil stresses may be abiotic factors such as water deficit, salinity, compaction, hypoxia due to flooding, soil temperature changes and mineral nutrient deficiencies or biotic factors such as herbivory by rhizophages, parasitization by nematodes and infection by fungi and other pathogens. Plant roots have therefore evolved to act as sensors of the soil environment and early warning detectors of the many potential soil stresses. In fact, the identity and mode of action of root-sourced chemical signals in general, is still not fully understood.

Root to shoot signaling under conditions of both mild and severe drought is an important area of research because of its implications for agricultural production and the water use efficiency (WUE) of plants (Davies et al. 2002; Schachtman and Goodger 2008). There have been a number of factors in the xylem sap that have been implicated in root signaling including ABA, pH, nitrate and other unidentified substances. The form of inorganic nitrogen (i.e., nitrate or ammonium) absorbed directly from the rhizosphere can influence plant performance in general and in particular, the susceptibility of a plant to abiotic stress. Nevertheless,

the effects of nitrogen source on root-sourced chemical signals and drought responses have not been studied systematically, despite their potential importance. Therefore we conducted a study varying the form of nitrogen nutrition available to plants whilst subjected to drought stress and assessed their responses by quantifying whole plant physiological parameters and xylem sap composition.

## II Nitrogen Source and Availability Influences Signaling Under Drought

The availability of nitrogen and other minerals is reduced as the soil dries, therefore drought and nutrient deficiency act synergistically in root to shoot signaling and ultimately on plant growth. Nitrogen, a key macronutrient for plants, is obtained via roots from the rhizosphere. Not only is the amount of nitrogen available to plants of critical importance, but the form in which nitrogen is obtained from the rhizosphere is very important as well. The source of inorganic nitrogen supply, whether ammonium or nitrate, influences proton fluxes, ion balance, carbohydrate metabolism and nitrogen assimilation in plants (Chaillou et al. 1991; Taylor and Bloom 1998). The species of nitrogen-containing molecules transported within the xylem stream from roots to shoots is largely determined by the source of inorganic nitrogen nutrition and can alter the xylem and in turn the apoplastic pH (Wilkinson and Davies 2002), thereby influencing nutrient uptake and plant growth (Kosegarten et al. 1999). Ammonium obtained from the soil is assimilated in the roots and is translocated to the shoots in the xylem as amino-nitrogen-compounds such as glutamine, asparagine or both (Arnozis and Findenegg 1986; Allen et al. 1988; van Beusichem et al. 1988; Schobert and Komor 1990). Nitrate obtained from the soil can be assimilated either in the roots or shoots depending on the plant species and environmental conditions (Engels and Marschner 1993). In many species, at least some of the total nitrogen in nitrate-fed plants is transported to the shoot in the form of  $\text{NO}_3^-$ , resulting in a greater demand for charge balance in the xylem sap (Engels and Marschner 1993) as compared to the uncharged amino acids resulting from ammonium assimilation.

---

*Abbreviations:* ABA – abscisic acid; ABA-GE – abscisic acid-glucose ester; ACO – ACC oxidase; ACC – 1-aminocyclopropane-1-carboxylic acid; BAP – 6-benzylaminopurine; DAS – days after sowing; LER – leaf elongation rate; ORC – outward rectifying channel; PRD – partial rootzone drying; WUE – water-use efficiency; Z – zeatin; ZN – zeatin nucleotide; ZR – zeatin riboside

When the water content of the soil decreases so does nitrate availability. Nitrate has also been suggested to be an important component in root to shoot signaling under drought and it is often associated with the alkalization of xylem sap. The absence of any effect of nitrate and ammonium ions on stomata in isolated epidermis contrasts with the significant effects of these same concentrations of ions when applied to whole leaves. These findings suggest an indirect effect of nitrate and ammonium on stomata rather than a direct effect on guard cells. The effect of nitrate or ammonium on apparent stomatal sensitivity to ABA could possibly be due to their effects on the modification of leaf apoplastic pH and the distribution of ABA in the leaf (Jia and Davies 2007).

The role of nitrate in modifying xylem sap pH has been studied and some authors suggest that it is a universal feature in root to shoot signaling of drought stress. Some examples of the effects of nitrate come from recent studies of detached leaves of *Commelina communis* fed with ammonium. These ammonium-fed leaves had increased transpiration rates whereas leaves fed with nitrate had decreased transpiration rates (Jia and Davies 2007). In maize, comparisons were made between plants grown with sufficient and deficient concentrations of nitrate. In water-stressed plants grown with potassium nitrate, transpiration rates were lower than in plants grown only with water (Wilkinson et al. 2007).

In our studies, we used ammonium or nitrate as the sole inorganic nitrogen source to modify sap pH in order to better understand the importance of

sap pH under drought, while at the same time shedding light on the changes occurring in the solute fluxes in xylem sap. A comprehensive approach to quantifying changes in sap solute concentrations was also attempted so as to thoroughly interpret the impact of nitrogen source on root to shoot signaling. Sap was collected at flow rates equivalent to whole plant transpiration in order to avoid dilution effects and data presented as flux rates. Previous studies have mainly shown that nitrate enhances the effects of drought. In our experiments, we also show how sap constituents change and suggest how this may alter sap proton flux and thereby influence the efficacy of ABA signaling. We used different nitrogen sources to change the apoplastic pH instead of comparing nitrogen deficiency to sufficient conditions. This minimized the differences in growth that occur when plants are nitrogen deficient. We found slightly higher growth rates in corn under conditions of ammonium nutrition as compared to nitrate nutrition as well as size variations within each treatment (Table 1). As suggested by Jackson (1997), when marked differences in size exist between plants, sap delivery rates can be refined to take account of the relative plant sizes. We therefore generated shoot dry weight specific delivery rates (e.g., nanomoles solute  $\text{g}^{-1} \text{s}^{-1}$ ) to account for size variability at the time of sap and biomass harvest. Similar refinements have been performed relating xylem sap flow rates to plant shoot fresh weights (Peuke and Jeschke 1993; Peuke et al. 1996, 2002) and plant root fresh weights (Engels and Marschner 1993).

*Table 1.* Plant and soil parameters for maize plants grown with ammonium (A) or nitrate (N) and subjected to well-watered (W) or water-stressed (S) conditions. Mean and SE of the parameters are presented along with 2-way ANOVA  $p$  values, where  $N$  and  $W$  represent nitrogen and water treatment, respectively. Leaf conductance to water is abbreviated as  $g_s$ , leaf extension rate as LER, and dry weight based root to shoot ratio as R:S. Soil water content in three different regions in the pots is shown. Data are from the day of sap and biomass harvest, 6 days after withholding water from the water-stress treatments (23 DAS).

Plant and Soil Parameters	AW		AS		NW		NS		ANOVA $p$ values		
	Mean	SE	Mean	SE	Mean	SE	Mean	SE	$N$	$W$	$N \times W$
$g_s$ ( $\text{mmol m}^{-2} \text{s}^{-1}$ )	116	3.4	97	5.5	103	2.5	83	7.3	0.01	0.00	–
LER ( $\text{mm d}^{-1}$ )	73	3.1	54	3.8	65	4.5	45	4.4	0.04	0.00	–
Shoot ( $\text{g}_{\text{dw}}$ )	2.5	0.2	1.9	0.14	1.7	0.20	1.6	0.2	0.00	–	–
root ( $\text{g}_{\text{dw}}$ )	0.8	0.04	1.0	0.04	0.7	0.03	0.8	0.05	0.00	0.00	–
R:S	0.4	0.02	0.5	0.03	0.4	0.03	0.6	0.04	–	0.00	–
Soil $\text{H}_2\text{O}$ (v/v):											
0–100 mm	24	0.8	19	0.60	22	1.0	19	0.6	–	0.00	–
100–200 mm	30	0.8	29	0.92	31	0.7	28	0.5	–	0.02	–
200–300 mm	47	1.5	40	1.13	44	1.4	40	0.8	–	0.00	–

## A Ammonium and Nitrate Nutrition Methods

We used the following methods in these experiments. Seeds of corn (*Zea mays* L. cv Fr697) were sown into large pots and grown as previously described (Goodger et al. 2005). Plants were randomly assigned to one of two nitrogen (N) fertilization groups, with one group supplied daily with ammonium-only ( $\text{NH}_4$ ) solution and the other group with nitrate-only ( $\text{NO}_3$ ) nutrient solution. The macronutrient composition of the solutions ( $\text{mol m}^{-3}$ ) was as follows: ' $\text{NO}_3$ ' solution:  $\text{KNO}_3$  2.0;  $\text{Ca}(\text{NO}_3)_2$  0.25;  $\text{KH}_2\text{PO}_4$  0.2;  $\text{MgSO}_4$  0.25; ' $\text{NH}_4$ ' solution:  $(\text{NH}_4)_2\text{SO}_4$  0.25;  $\text{CO}(\text{NH}_2)_2$  1.0;  $\text{CaCl}_2$  0.25;  $\text{KH}_2\text{PO}_4$  0.2;  $\text{MgCl}_2$  0.25;  $\text{KCl}$  2.0. The micronutrient composition of both solutions ( $\text{mol m}^{-6}$ ) was the same:  $\text{MnCl}_2$  0.5;  $\text{H}_3\text{BO}_3$  1.0;  $\text{Na}_2\text{MoO}_4$  0.005;  $\text{CoCl}_2$  0.005;  $\text{ZnSO}_4$  0.3;  $\text{CuSO}_4$  0.1;  $\text{FeNaEDTA}$  100. The nitrification inhibitor Dicyandiamide (Sigma, St. Louis, USA; 80  $\text{mol m}^{-6}$ ) was also added to both N solutions and the pH of each solution was adjusted to 5.8 with HCl.

Water was withheld from half of the pots in each N group from 17 days after sowing (DAS) thereby producing four experimental groups:  $\text{NH}_4$  well-watered,  $\text{NO}_3$  well-watered,  $\text{NH}_4$  water-stressed, and  $\text{NO}_3$  water-stressed. Soil moisture content (v/v) was monitored daily on plants from each group using a PR-1 profile probe (Delta-T Devices, Cambridge, UK) as described by Goodger et al. (2005).

Twelve plants from each of the four groups were randomly selected for daily leaf measurements and were also used for pressurized sap extraction and biomass determinations. The length of the expanding sixth leaf from each plant was measured at the same time every day from 17 DAS and used to determine leaf elongation rate (LER;  $\text{mm d}^{-1}$ ). Daily leaf conductance ( $g_s$ ) from 20 DAS was measured on the abaxial surface of fourth leaf (avoiding major veins) for the same plants using an AP4 steady-state porometer (Delta-T Devices, Cambridge, UK). Immediately after sap extraction, roots were removed from the pots and cleaned of soil, and both roots and shoots were dried at  $60^\circ\text{C}$  for 96 h before dry weight (dw) determinations.

Sap was extracted from plants in all four groups 6 days after water was withheld (23 DAS)

as described in Goodger et al. (2005). The rate of exudation from the cut mesocotyl stumps was increased by application of pressure to the roots (ranging from 0.28 to 0.32 MPa) to produce sap exudation rates that were comparable with the rates of sap flow determined by whole plant transpiration measures prior to the harvest. The duration of sap collection was recorded and all sap samples were frozen immediately and stored at  $-80^\circ\text{C}$  until analyzed. The pH of sap samples and the concentration of ABA, cations, anions and organic acids were analyzed as described in Goodger et al. (2005).

## B Ammonium and Nitrate Fertilization Alters Response to Drought

Table 1. highlights the differences observed in leaf conductance, leaf elongation rate and overall biomass accumulation under different treatments. Overall leaf conductance and leaf growth were significantly affected by both water stress and nitrogen treatment. The plants grown on nitrate transpired and grew less than the plants grown under ammonium only conditions. Plants in both treatments responded to drought in terms of decreased conductance and growth as well as by a classical increase in root to shoot ratios. These data provide a framework for interpreting the changes in xylem sap constituents that we observed in Table 2.

The measurement of leaf conductance over time confirmed the endpoint measurements shown in Table 1. The transpiration of plants grown under nitrate nutrition was lower than in plants grown with ammonium (Fig. 1). The lower transpiration and growth under nitrate nutrition confirms results shown by others that nitrate plays a role in sensitization of stomata to ABA (Bahrun et al. 2002; Wilkinson and Davies 2002; Jia and Davies 2007). Maize did not exhibit large differences in the pH of the xylem sap from roots under nitrate or ammonium nutrition, although the sap was slightly more acidic under drought conditions when plants were grown with ammonium. However, when the data were expressed as sap flux per gram shoot biomass, large differences in proton fluxes were detected (Table 2). A multiple regression analysis was performed in order to determine the relationship between sap protons, sap ABA and leaf transpiration in maize

*Table 2.* Flux of xylem sap constituents for maize plants grown with ammonium (A) or nitrate (N) and subjected to well-watered (W) or water-stressed (S) conditions. Mean and SE of the constituents are presented as sap flux per  $g_{dw}$  shoot mass, except for pH which is presented simply as pH units. The units are  $nmol\ s^{-1}\ g^{-1}$  for all constituents except for proton ( $pM\ s^{-1}\ g^{-1}$ ), ABA ( $fmol\ s^{-1}\ g^{-1}$ ). Significant 2-way ANOVA  $p$  values are also presented with  $N$ ,  $W$  and  $N \times W$  representing the nitrogen treatment, water treatment and interaction, respectively.

Sap parameters	AW		AS		NW		NS		ANOVA $p$ values		
	Mean	SE	Mean	SE	Mean	SE	Mean	SE	$N$	$W$	$N \times W$
Proton	6.26	0.55	5.24	0.40	4.65	0.22	2.85	0.23	0.00	0.00	–
ABA	0.59	0.07	2.38	0.48	0.62	0.08	2.16	0.69	–	0.00	–
Malate	1.60	0.22	2.87	0.31	1.64	0.26	4.55	0.65	–	0.00	–
Citrate	0.20	0.03	0.21	0.02	0.28	0.04	0.23	0.04	–	–	–
Succinate	0.16	0.02	0.16	0.02	0.16	0.02	0.22	0.02	–	–	–
Nitrate	0.26	0.03	0.25	0.03	5.04	0.84	0.59	0.18	0.00	0.00	0.00
Chloride	9.93	0.71	10.81	0.78	8.79	1.01	7.43	1.30	0.03	–	–
Phosphate	3.11	0.35	5.11	0.51	3.79	0.45	7.33	0.86	0.02	0.00	–
Sulfate	1.12	0.14	1.35	0.15	2.19	0.10	1.93	0.37	0.00	–	–
Ammonium	0.07	0.01	0.12	0.02	0.09	0.02	0.04	0.01	0.03	–	0.00
Potassium	8.45	0.65	10.55	0.81	11.67	1.12	12.34	1.11	0.01	–	–
Magnesium	0.65	0.07	0.95	0.10	0.94	0.11	1.20	0.16	0.02	0.02	–
Calcium	0.47	0.05	0.65	0.06	0.67	0.07	0.78	0.09	0.02	0.04	–
Sodium	0.02	0.00	0.03	0.01	0.03	0.01	0.06	0.03	–	–	–

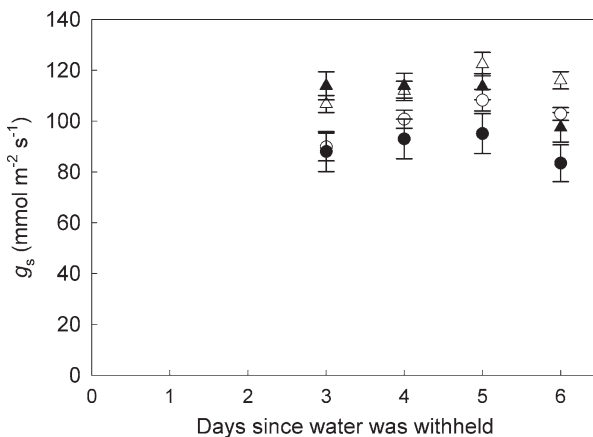

*Fig. 1.* Leaf conductance of plants grown with ammonium (triangle symbols) or nitrate (circle symbols). Water was withheld on day 0 in these experiments from half the plants (filled symbols – water stressed) and the other half remained well watered (open symbols – well watered).

(Fig. 2). This analysis clearly showed that there is a highly significant relationship between pH, leaf conductance and ABA in all the treatments (water stress and nitrogen nutrition).

The ammonium versus nitrate treatments successfully allowed us to manipulate xylem sap proton flux which clearly resulted in changes of stomatal conductance and leaf growth. The next question is how then does nitrogen nutrition

contribute to the changes in proton flux and stomatal responses to drought?

### III Charge Balance in the Xylem Accounts for Changes Induced by Nutrition and Drought

One hypothesis in the literature is that nitrate reduction shifts from shoots to the roots when drought causes a decrease in nitrate availability (Lips 1997; Liu et al. 2005). The switch in nitrate reductase activity would lead to increased hydroxyl ion production and alkalization. In addition, one feature that has been noted for xylem sap, but for which the mechanism is not understood, is that the balance between cations and anions is generally maintained, providing “charge balance” (Jeschke and Hartung 2001). This has been quantified and confirmed in at least one study (Gollan et al. 1992). Using a comprehensive analysis of xylem sap (Goodger et al. 2005), we also found that the relationship between cations and anions in the xylem sap is constant in well-watered and water-stressed plants grown under different nitrogen treatments. Therefore, we put forward the hypothesis that charge balance is a key factor in determining the changes in the xylem sap composition when plants are water stressed or deprived of nitrate. The mechanism behind the



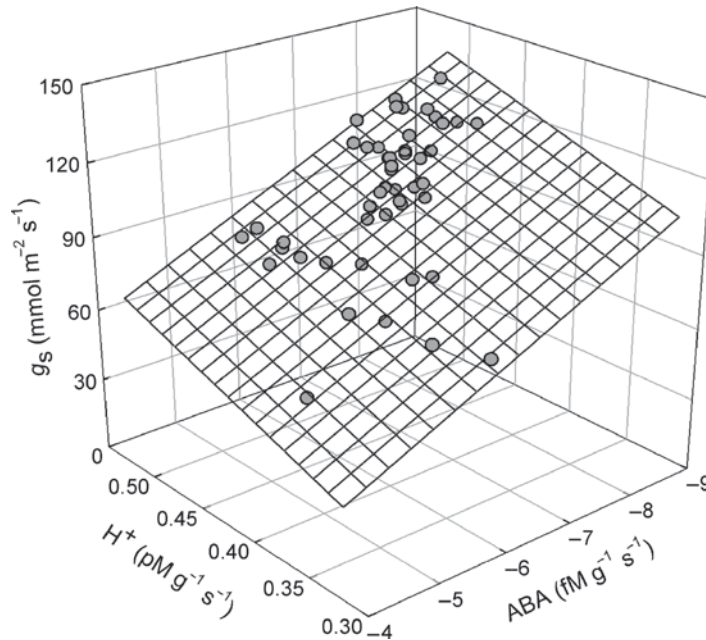

Fig. 2. Maize leaf conductance ( $g_s$ ) decreases as the proton delivery rate per unit shoot biomass decreases per unit ABA. Symbols represent sap collected from 40 maize plants grown under ammonium or nitrate-only fertilization and well-watered or water-stressed conditions to induce a range of sap pH and leaf conductances. Proton and ABA data were linearised using a box-cox transformation to enable a plane regression to be performed. The regression is significant ( $F=23.01$ ,  $P \leq 0.0001$ ;  $r^2=0.51$ ).

maintenance of charge balance could possibly be due to the requirement for charge balance of ion efflux from xylem parenchyma cells but may also involve other cells in the stele. In Fig. 3, the very strong correlation between total anions and total cations shows that in maize this balance is maintained in the face of sap changes induced by both N form and water stress.

Therefore, we suggest that in order to maintain charge balance, biochemical functions in maize roots are redirected for adaptation to different nutrient and moisture conditions and this redirection results in changes in the xylem sap pH or proton flux.

#### IV Ammonium and Nitrate Grown Plants: Changes in Xylem Sap Composition

In this section we briefly outline the changes that are caused by nitrogen source and drought and that lead to changes in xylem sap composition.

##### A Ammonium Nutrition

In plants grown under well-watered conditions and ammonium nutrition, assimilation probably occurs in roots, and nitrogen is transported to the shoots as the electro-neutral amino acid glutamine (Gollan et al. 1992). This is suggested in part by the very low concentrations of ammonium and nitrate even in the sap of plants that are grown only on ammonium (Table 2). These plants have the same levels of ammonium in xylem sap as the nitrate-grown plants. It is also known that glutamine is found in high concentrations in the xylem sap of many plant species (Gollan et al. 1992). In this case, pH does not become more alkaline and the flux of protons is at its highest, and low levels of ABA are insufficient to reduce stomatal conductance.

When ammonium-fed plants are subjected to water stress, ammonium availability decreases and ABA synthesis in the root increases (Sharp et al. 2004). We speculate that increased proton efflux from roots could acidify the rhizosphere

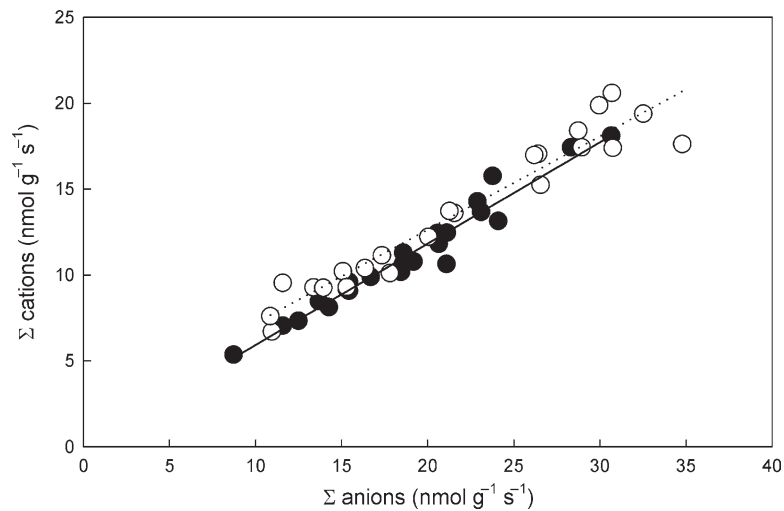

Fig. 3. Sum of anion plotted against the sum of cation flux per shoot mass for ammonium-fed plants (*closed symbols*) and nitrate-fed plants (*open symbols*). Anions are nitrate, chloride, sulfate and phosphate, and the major organic acids malate, succinate and citrate. Cations are ammonium, potassium, sodium, magnesium and calcium. A linear regression performed on the ammonium data is significant (solid line;  $F=493.7$ ,  $p<0.0001$ ) and has a slope of 1.62 and  $r^2=0.96$ . A linear regression performed on the nitrate data is significant (dotted line;  $F=284.5$ ,  $p<0.0001$ ) and has a slope of 1.71 and  $r^2=0.93$ . An analysis performed on the regression lines showed that the slopes are not significantly different ( $F=2.96$ ,  $p=0.1$ ).

to solubilize more  $\text{NH}_4$ . This results in increased  $\text{OH}^-$  in roots which is charge balanced by root-sourced carboxylate production (malate) that increases in the sap under water stress. Malate concentrations in ammonium-grown and drought-stressed maize sap increases (Table 2) and contribute to alkalization of the sap due to a  $\text{pK}_a$  of 5.13. Overall, this results in decreased proton flux which enhances the ABA effect on reducing stomatal conductance relative to the well-watered and ammonium-grown plants.

### B Nitrate Nutrition

Under conditions of nitrate nutrition and well-watered conditions, nitrate is mainly assimilated in the shoot and therefore large quantities of nitrate are transported in xylem from roots to shoot (Table 2). Nitrate alkalizes sap, increasing the efficacy of low concentrations of ABA on guard cells which results in reduced stomatal conductance relative to the well-watered ammonium-grown plants. Plants that are well fertilized with nitrate will tend to show higher xylem and apoplastic pH (Mühling and Läuchli 2001). It has also been shown that nitrate ions fed through

the transpiration stream can alkalize the leaf apoplast (Jia and Davies 2007).

When nitrate-fed plants are subjected to water stress, there is an increase in ABA synthesis and a reduction in nitrate entering the root which leads to a switch in nitrate assimilation to roots. The reduced availability of nitrate and the switch to nitrate reduction in the roots is suggested by the large decrease in the nitrate concentrations of xylem sap in water-stressed plants (Table 2). Where nitrate is reduced in the roots more hydroxyl ions are produced which are converted to  $\text{COO}^-$  (often as malate) and transported to the leaf in the xylem (Table 2). Malate and related compounds alkalize the xylem and/or apoplastic sap to an even greater degree than nitrate (Butz and Long 1979; Engels et al. 1994). Under water stress and nitrate nutrition, transpiration and proton flux were lowest (Tables 1 and 2). The reduced proton flux further enhanced the effects of ABA on stomatal closure. Similarly, Jia and Davies (2007) also discovered that soil drying led to an increase in xylem sap pH and a decrease in nitrate content of xylem sap. In those experiments, the addition of extra nitrate to reduce the soil drying-induced decrease of xylem sap nitrate

content was not able to prevent the pH increase (Jia and Davies 2007). The results from our studies suggest that the soil drying-induced pH increase in tomato was not related to the changes in nitrate content of xylem sap but most likely due to increased malate production and transport in the xylem.

In gramineous plants, such as maize with comparably low concentrations of  $\text{Ca}^{2+}$  and  $\text{Mg}^{2+}$  in the shoot tissue, the negative charge of nitrate in the xylem is presumably counterbalanced mainly by  $\text{K}^+$  (Engels and Kirkby 2001). Increased  $\text{K}^+$  is also observed in nitrate-grown plants and under water stress. The increased  $\text{K}^+$  may be required to balance the charge due to the increased malate flux.

## V Conclusions

Overall, the ABA flux  $\text{g}^{-1}$  is not different between water-stressed plants grown with ammonium or nitrate (Table 2), but stomatal conductance ( $g_s$ ) is lower in nitrate-grown plants (Fig. 1; Table 1). This suggests that other factors such as proton flux account for the differences in the control of transpiration rates and the more rapid response to water stress in the nitrate-grown plants.

## Acknowledgement

Thanks to Christine Ehret for assistance in editing and formatting this chapter. The work was funded by a Plant Genome Program Grant No. (NSF-DBI-0211842) to DPS.

## References

- Allen S, Raven JA, Sprent JI (1988) The role of long-distance transport in intracellular pH regulation in *Phaseolus vulgaris* grown with ammonium or nitrate as nitrogen source or nodulated. *J Exp Bot* 39:513–528
- Arnozis PA, Findenegg GR (1986) Electrical charge balance in the xylem sap of beet and *Sorghum* plants grown with either  $\text{NO}_3^-$  or  $\text{NH}_4^+$  nitrogen. *J Plant Physiol* 125:441–449
- Bahrn A, Jensen CR, Asch F, Mogensen VO (2002) Drought-induced changes in xylem pH, ionic composition and ABA concentration act as early signals in field-grown maize (*Zea mays* L.). *J Exp Bot* 53:251–263
- Butz R, Long R (1979) L-malate as an essential component of the xylem fluid of corn seedling roots. *Plant Physiol* 64:684–689
- Chaillou S, Vessey JK, Morot-Gaudry JF, Raper CDJ, Henry LT, Boutin JP (1991) Expression of characteristics of ammonium nutrition as affected by pH of the root medium. *J Exp Bot* 42:189–196
- Davies WJ, Wilkinson S, Loveys B (2002) Stomatal control by chemical signalling and the exploitation of this mechanism to increase water use efficiency in agriculture. *New Phytol* 153:449–460
- Engels C, Kirkby EA (2001) Cycling of nitrogen and potassium between shoot and roots in maize as affected by shoot and root growth. *J Plant Nutri Soil Sci* 164:183–191
- Engels C, Marschner H (1993) Influence of the form of nitrogen supply on root uptake and translocation of cations in the xylem exudate of maize (*Zea mays* L.). *J Exp Bot* 44:1695–1701
- Engels C, Buerkert B, Marschner H (1994) Nitrogen and sugar concentrations in xylem exudate of field-grown nitrogen at different growth stages and levels of nitrogen fertilization. *Eur J Agron* 3:197–204
- Gollan T, Schurr U, Schulze ED (1992) Stomatal response to drying soil in relation to changes in the xylem sap composition of *Helianthus annuus*. 1. The concentration of cations, anions, amino acids in, and pH of, the xylem sap. *Plant Cell Environ* 15:551–559
- Goodger JQ, Sharp RE, Marsh EL, Schachtman DP (2005) Relationships between xylem sap constituents and leaf conductance of well-watered and water-stressed maize across three xylem sap sampling techniques. *J Exp Bot* 56:2389–2400
- Jackson MB (1997) Hormones from roots as signals for the shoots of stressed plants. *Trends Plant Sci* 2:22–28
- Jeschke WD, Hartung W (2001) Root-shoot interactions in mineral nutrition. *Plant Soil* 226:57–69
- Jia W, Davies WJ (2007) Modification of leaf apoplast pH in relation to stomatal sensitivity to root-sourced abscisic acid signals. *Plant Physiol* 143:68–77
- Kosegarten H, Grolig F, Esch A, Glusenka K, Mengel K (1999) Effects of  $\text{NH}_4^+$ ,  $\text{NO}_3^-$  and  $\text{HCO}_3^-$  on apoplast pH in the outer cortex of root zones of maize, as measured by the fluorescence ratio of fluorescein boronic acid. *Planta* 209:444–452
- Lips SH (1997) The role of inorganic nitrogen ions in plant adaptation processes. *Russian J Plant Physiol* 44:421–431
- Liu FL, Jensen CR, Andersen MN (2005) A review of drought adaptation in crop plants: changes in vegetative and reproductive physiology induced by ABA-based chemical signals. *Aust J Agric Res* 56:1245–1252
- Mühling KH, Läubli A (2001) Influence of chemical form and concentration of nitrogen on apoplastic pH of leaves. *J Plant Nutr* 24:399–411
- Peuke AD, Jeschke WD (1993) The uptake and flow of C, N and ions between roots and shoots in *Ricinus communis*

- L. I. Grown with ammonium or nitrate as nitrogen source. *J Exp Bot* 44:1167–1176
- Peuke AD, Glaab J, Kaiser WM, Jeschke WD (1996) The uptake and flow of C, N and ions between roots and shoots in *Ricinus communis* L. IV. Flow and metabolism of inorganic nitrogen and malate depending on nitrogen and salt treatment. *J Exp Bot* 47:377–385
- Peuke AD, Jeschke WD, Hartung W (2002) Flows of elements, ions and abscisic acid in *Ricinus communis* and site of nitrate reduction under potassium limitation. *J Exp Bot* 53:241–250
- Schachtman DP, Goodger JQD (2008) Chemical root to shoot signaling under drought. *Trends Plant Sci* 577: 1360–1385
- Schobert C, Komor E (1990) Transfer of amino acids and nitrate from roots into xylem of *Ricinus communis* seedlings. *Planta* 181:85–90
- Sharp RE, Poroyko V, Hejlek LG, Spollen WG, Springer GK, Bohnert HJ, Nguyen HT (2004) Root growth maintenance during water deficits: physiology to functional genomics. *J Exp Bot* 55:2343–2351
- Taylor AR, Bloom AJ (1998) Ammonium, nitrate, and proton fluxes along the maize root. *Plant Cell Environ* 21:1255–1263
- van Beusichem ML, Kirkby EA, Baas R (1988) Influence of nitrate and ammonium nutrition on the uptake, assimilation, and distribution of nutrients in *Ricinus communis*. *Plant Physiol* 86:914–921
- Wilkinson S, Davies WJ (2002) ABA-based chemical signalling: the co-ordination of responses to stress in plants. *Plant Cell Environ* 25:195–210
- Wilkinson S, Bacon MA, Davies WJ (2007) Nitrate signalling to stomata and growing leaves: interactions with soil drying, ABA and xylem sap pH in maize. *J Exp Bot* 58:1705–1716



# Part II

## **Stress Regulation of Gene Expression**

## Abiotic Stress Responses: Complexities in Gene Expression

Vaishali Panjabi-Sabharwal, Ratna Karan, Tanveer Khan,  
and Ashwani Pareek\*

*Stress Physiology and Molecular Biology Laboratory,  
School of Life Sciences, Jawaharlal Nehru University,  
New Delhi, 100067, India*

Summary .....	178
I Introduction.....	178
II Signal Transduction Pathways Under Abiotic Stresses.....	179
III Resources for Identification of Novel Genes.....	180
IV Genomics-based Approaches for Understanding the Response of Plants Towards Abiotic Stresses.....	182
A Identification of QTLs for Tolerance to Abiotic Stresses .....	183
B Analysis of Transcript Profiles: Transcriptomics .....	183
1 Transcriptome Analysis using High-Throughput Techniques.....	185
2 Transcriptional Profiling Reveals That Metabolic Re-Adjustment is a Hallmark of Abiotic Stress Response .....	186
C Large Scale Study of Proteins: Proteomics .....	189
D Metabolomics.....	192
V Interactome.....	192
A Interacting Partners of Two Component System.....	192
B High Throughput Yeast Two Hybrid Analysis.....	193
C Prediction of Protein–Protein Interactions Using Bioinformatics and Development of Protein Interactome Databases.....	194
VI Future Prospects .....	194
Acknowledgements .....	195
References .....	195

---

\* Author for Correspondence, e-mail: ashwanip@mail.jnu.ac.in

## Summary

Abiotic stresses are being considered as one of the major threats to agriculture. Studies carried out by plant breeders, as well as molecular biologists, have clearly documented that the response of plants towards these stresses is multigenic in nature. Plants have been documented to have evolved delicate mechanisms to cope with these abuses. The availability of whole genome sequences and tools to analyze regulation of its “member components”, at transcript and protein levels, have revolutionized the way stress biology is being currently studied. These investigations have given an insight into how extracellular signals are perceived and transmitted through signal transduction cascades in a given plant. It has been established that upon receipt and transmission of the stress signal(s), expression of a number of gene is altered, leading to stress adaptation in plant cells. Recently, studies carried out at the genome level, using microarrays, have shown the significance and contribution of these gene regulatory networks in making a given plant “stress tolerant” or “stress sensitive”. Presently, our understanding of the protein–protein interactions, post translational modifications or metabolite fluxes is less developed, as compared to that of transcriptional changes. With the current technological leaps, we hope that these gaps in our knowledge will be filled soon, and thus we will be able to successfully “tame” these abiotic stresses in the future.

**Keywords** Genome • interactome • metabolic profiling • microarrays • proteome • transcriptome

## I Introduction

Plants are exposed to various biotic and abiotic stresses in their natural environment. World-wide, abiotic stress conditions cause a major loss to the agricultural productivity. The wide array of abiotic factors affecting crop productivity includes salinity, drought, submergence, temperature extremes (high and low temperatures) and heavy metals. Almost a third of the total area farmed, is

affected by salt or the associated water logging or alkalinity. The gains in agricultural output provided by the onset of the green revolution have reached their maximum, whereas the world population continues to rise. In this regard, it has been estimated that in order to meet the needs of the growing population, plant productivity needs to be increased by at least 20% in the developed countries and 60% in the developing countries. This increasing demand, coupled with shrink-

---

*Abbreviations:* AREB – ABRE binding protein; ABA – abscisic acid; ABRE – abscisic acid responsive element; AP2 – activator protein-2; AtPID – *Arabidopsis thaliana* protein interactome database; APX – ascorbate peroxidase; CDPK – calcium dependent protein kinase; CE – capillary electrophoresis; cDNA AFLP – cDNA amplified fragment length polymorphism; CRT – C-repeat; CBF – CRT binding factor; Cvt – cytoplasm to vacuole targeting; DRE – dehydration responsive element; DREB – dehydration responsive element binding protein; DDPCR – differential display polymerase chain reaction; DBD – DNA binding domain; ESI-MS – electrospray ionization mass spectrometry; ERFs – ethylene response factors; EREBPs – ethylene responsive element binding proteins; EMS – ethyl methyl sulphonate; ESTs – expressed sequence tags; ECM proteins – extracellular matrix proteins; GC-TOF-MS – gas-chromatograph time of flight mass spectrometry; GC – gas chromatography;

GST – glutathione-S-transferase; GSK – glycogen synthase kinase-shaggy kinase; HLH – helix-loop-helix; HPLC – high performance liquid chromatography; ICP-MS – inductively coupled plasma mass spectrometry; LEA – late embryogenesis abundant proteins; MALDI-TOF – matrix assisted laser desorption-ionization time of flight; MAPK – mitogen activated protein kinase; NAC – NAM, ATAF and CUC transcription factor; NAM – no apical meristem; NMR – nuclear magnetic resonance; ORF – open reading frame; PHD – plant homeo domain; PCR – polymerase chain reaction; PID – protein interaction database; Q-TOF-MS – quadrupole time of flight mass spectrometry; QTL – quantitative trait loci; ROS – reactive oxygen species; RLK – receptor like kinase; SOS – salt overly sensitive; SAGE – serial analysis of gene expression; SNP – single nucleotide polymorphism; SSH – suppression subtractive hybridization; TF – transcription factors; 2-DE – two-dimensional gel electrophoresis

ing resources has fuelled scientific research in elucidating the mechanisms by which plants respond to stress. We expect that the successful application of biotechnology as well as the classical plant breeding methods would lead to the development of stress-tolerant crop plants, which would further lead to enhanced food production.

This chapter is an attempt to present our current understanding related to signaling under stress conditions in plants. We present various technologies which have been utilized in the recent past to explore the gene expression changes in plants under stressful and unfavorable conditions. These interactions appear to be quite complex as revealed by studies targeted towards understanding alterations at transcriptome, proteome and protein–protein interaction levels. Here, we have briefly discussed the interactions among signaling members; further details are available in other chapters of this book.

## II Signal Transduction Pathways Under Abiotic Stresses

Signaling pathways are induced in response to environmental stresses, and recent molecular and genetic studies have revealed that these pathways involve a host of diverse responses (Chinnusamy et al. 2004; Sreenivasulu et al. 2007). A stress response is initiated when a plant recognizes stress at the cellular level. Signal recognition activates signal transduction pathways which result in altered gene expression and metabolism readjustment at this cellular level, some of which get translated to an altered physiological state that results in better acclimatization of the plant towards abiotic stress conditions. Sensors are molecules that perceive the initial stress signal. Sensors initiate (or suppress) a cascade to transmit the signal intracellularly and in many cases, activate nuclear transcription factors to induce the expression of specific sets of genes. Drought, salt and cold stresses have been shown to induce transient  $\text{Ca}^{2+}$  influx into the cell cytoplasm, which arises due to influx of  $\text{Ca}^{2+}$  from the apoplastic space or release from internal stores (Zhu 2002). In plants, the major signaling pathways operative under abiotic stress, which lead to changes in gene expression and ultimately determine the stress response, include (details of these pathways are presented in Text Box 9.1 and also in Chapter 1–5 of this book):

- Gene expression changes that are brought in via the mitogen activated protein kinase (MAPK) pathway (to regulate redox homeostasis)
- Gene expression changes for late embryogenesis abundant proteins (LEA)-type genes (to regulate osmotic homeostasis in the cells)
- Changes in salt overly sensitive (SOS) signaling pathway (to regulate ion homeostasis in the cells)
- Gene alterations as mediated via hormone-signaling pathways

### Box 9.1 The Major Signaling Pathways Operative Under Abiotic Stress in Plants

#### *MAPK Pathway*

The MAPK pathway is activated by ROS and also by receptors/sensors such as protein tyrosine kinases, G-protein coupled receptors or two-component histidine kinases. The oxidative burst, that is, production of reactive oxygen species is one of earliest response of plant to any kind of stress. The reaction of ROS species with plant proteins/lipids can have a detrimental effect on the plant and may eventually lead to its death. Plant cells have, therefore, developed mechanisms to constantly monitor and manage the levels of reactive oxygen species (ROS) accumulating within their cytosol and organelles. One of the earliest responses to ROS perturbations in plants cells is the activation of specific mitogen-activated protein (MAP) kinases, which eventually trigger the synthesis of enzymes involved in oxidative protection. The osmotic adjustment, a hallmark of abiotic stress tolerance in plants, is also mediated by the MAPK signal transduction pathway (Zhu 2002).

#### *LEA Genes*

LEA or late embryogenesis abundant proteins are expressed during cellular desiccation and are accumulated to very high concentrations by the seeds during later stages of embryo development. Water deficit, high osmolarity and low

(continued)



### Box 9.1 (continued)

temperature stress results in the accumulation of a group of LEA proteins (Wang et al. 2003). Such proteins may preserve protein structure and membrane integrity by binding water, preventing protein denaturation or renaturation or protein unfolding and sequestering ions in stressed tissues. LEA proteins and chaperones have shown to be involved in protecting macromolecules like enzymes, lipids and mRNAs from dehydration. The CDPK pathway seems to be involved in increasing the expression of LEA proteins from cellular desiccation.

#### SOS Pathway

SOS signaling appears to be relatively specific for the ionic aspect of salt stress. The targets of this pathway are ion transporters that control ion homeostasis under salt stress (Seki et al. 2003). An early response to sodium stress is a transient increase in the calcium level. The ionic aspect of salt stress is signaled via the SOS pathway, where a calcium responsive SOS3-SOS2 protein kinase complex controls the expression and activity of ion transporters such as SOS1. The  $\text{Ca}^{2+}$  signaling is perceived by the calcineurin-B-like  $\text{Ca}^{2+}$  sensor SOS3, which in turn interacts and activates protein kinase SOS2 by phosphorylation. The activated SOS2 then modulates the activity of plasma membrane localized  $\text{Na}^+/\text{H}^+$  antiporter SOS1.

#### ABA Mediated Pathway

ABA is a phytohormone that is extensively involved in abiotic stress responses towards drought, low temperature, and osmotic stress. In plants, two kinds of cis-acting sequences have been reported to be involved in ABA-mediated gene expression. The first one is the ABA-responsive element (ABRE). It has been shown that the bZIP transcription factors, like ABRE-binding factor (ABF)/ABRE binding protein (AREB), can activate the stress-responsive RD29A promoter through binding to the ABRE motifs (Boudsocq and Lauriere 2005). It has been shown that MYB and MYC

transcription factors are involved in an ABA-dependent pathway, leading to the expression of drought-responsive genes like RD22 (Abe et al. 2003). This ABA-independent expression of stress-responsive genes can occur through dehydration-responsive element (DRE)/C-repeat (CRT) cis-acting elements. The binding factors CBF/DREB1 (CRT-binding factor/DRE-binding factor 1) and DREB2 mediate gene expression in response to cold and drought/salinity, respectively. These aspects of stress signaling have been dealt with detail in Chapter 3.

### III Resources for Identification of Novel Genes

The comparative genomics approach has proven to be a highly valuable tool for unveiling the key genetic contributors to the complex physiological processes, involved in abiotic stress tolerance (Eddy and Storey 2008). Comparative stress genomics essentially means scoring of various commonalities and differences in the expression patterns of different genes among populations that differ in stress tolerance. The identification of various abiotic stress specific changes in gene expression can be achieved by comparing gene expression in non-induced and stress-induced tissues or by comparing genetically different genotypes such as the various contrasting cultivars (Sahi et al. 2003; Kumari et al. 2009). Prokaryotic extremophiles have also been used as a source of useful genes as they can survive under the conditions where other plants cannot (Fig. 1). Similarly, another important target of plant scientists is to create “variability”, as it can serve as a useful tool for studying gene expression. An example of this approach is the identification of SOS pathway and its specific mutants in *Arabidopsis* (Zhang et al. 2004). Among other approaches, availability of contrasting genotypes in crop species has been well exploited and several reports have been published in the past where molecular mechanisms of stress responses have been looked into, using these genotypes. For example, Inan et al. 2004 noted that a fewer number of genes were induced under salt stress in *Thellungiella halophila* (salt cress – a salt tolerant relative of *Arabidopsis*) in contrast to that in *Arabidopsis*. This analysis

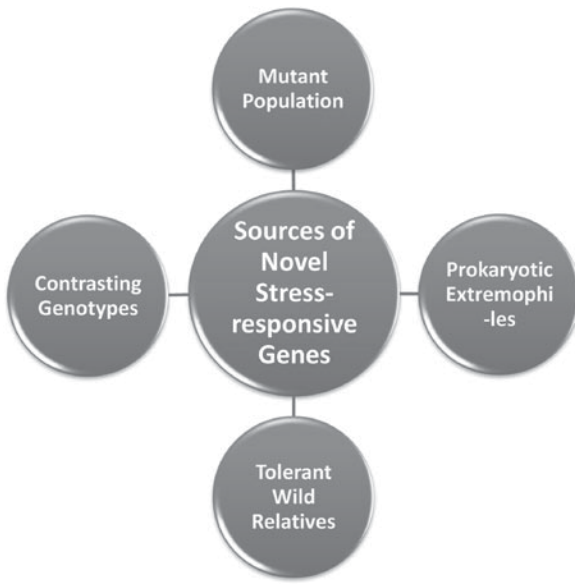

Fig. 1. Sources of genes for raising stress tolerant plants. Stress responsive genes from mutant populations, prokaryotic extremophiles, contrasting genotypes and tolerant wild relatives, can be used to raise stress tolerant plants.

revealed an important aspect of stress tolerance mechanism, where the stress tolerance of salt stress may be due to constitutive over-expression of many genes that function in salt tolerance and are only stress inducible in *Arabidopsis* (Taji et al. 2004). Similarly, global gene expression analyses in rice revealed a strikingly large spectrum of gene expression changes induced by salinity stress in salt sensitive genotypes, as compared to the tolerant lines (Walia et al. 2005, 2007). A total of 164 expressed sequence tags (ESTs) were upregulated

in the tolerant line (FL478) under salinity stress. A nearly equal number of ESTs were found to be significantly down-regulated under salinity stress in FL478. In contrast, a total of 456 probe sets were induced by salinity stress in salt sensitive IR29 and the expression of 184 ESTs was suppressed. However, only eight ESTs were common between the two, that is, FL478 and IR29, during salinity stress (Walia et al. 2005). Similar observations were also made in the case of tomato, where total 11 genes were upregulated and 14 were downregulated in a tolerant genotype (LA2711) in a specific manner, while 43 and 76 genes were upregulated and downregulated, respectively, only in the sensitive genotype (ZS-5). A total of 26 and 31 genes were commonly upregulated and downregulated, respectively, between the two genotypes (Ouyang et al. 2007). Our own work related to the analysis of salinity stress responsive gene alterations in rice and *Brassica*, is also in corroboration with the above observations (Kumari et al. 2009; Kumar et al. 2009; Karan et al. 2009). Thus, increasing evidence has accumulated for a range of plant species, which suggests that constitutive gene expression patterns are major mechanisms responsible for the observed differences in basal stress tolerance of various plants (Fig. 2).

The stress-tolerant genotypes of important plant species may serve as an important gene pool for the identification of useful genes (Kumar et al. 2009). Also, the identification of these genes, which may be involved in the stress response and contribute towards stress tolerance, may prove useful for understanding the underlying molecular mechanisms. With this

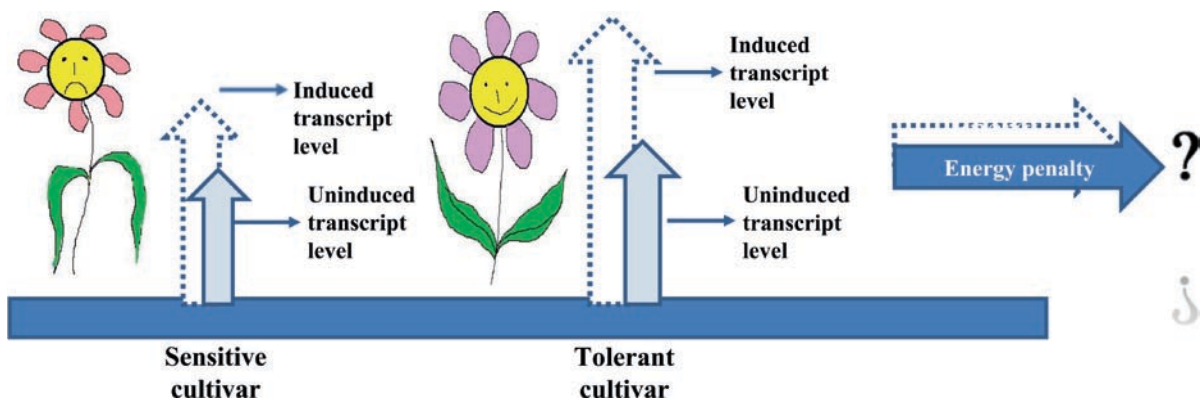

Fig. 2. Preparedness of the tolerant cultivar by maintenance of relatively higher level of transcripts of stress related genes [See Color Plate 4, Fig. 7].

view, major EST sequencing efforts have been initiated for the halophyte *Mesembryanthemum crystallinum* ([www.compbio.dfci.harvard.edu/tgi/gi/mcgi](http://www.compbio.dfci.harvard.edu/tgi/gi/mcgi)). The EST sequencing has also been initiated in the bryophytes *Tortula ruralis* and *Physcomitrella patens*, for the identification of desiccation-tolerance related genes (Oliver et al. 2000).

Besides EST sequencing projects, other approaches are also being used for the identification of useful stress responsive genes. For example, insertional mutagenesis in plants has the advantage of its genome-wide distribution with preferential insertion in genic regions. Saturation mutagenesis has been achieved for both rice and *Arabidopsis* with T-DNA gene insertions covering more than 90% of the genes and they have been widely employed to characterize abiotic stress responsive genes. The retrotransposon *Tos17* has also been used for large scale mutagenesis in case of rice (Hirochika 2001; [www.genoscope.cns.fr/spip/oryza-sativa-retrotransposon-tos17](http://www.genoscope.cns.fr/spip/oryza-sativa-retrotransposon-tos17)). These lines have been used to study the role of stress-responsive rice genes such as metallothioneins (Wong et al. 2004), histidine kinases (Pareek et al. 2006) and OsTPC1 – putative voltage gated  $Ca^{2+}$  permeable channels (Kenji et al. 2004). In rice, random mutants have been generated for cv. IR64 using chemical mutagens (such as EMS) and irradiation by fast neutrons or gamma-rays. These mutants have been used to generate pools for TILLING – a high-throughput technology useful for identifying mutations in selected genes or a variant allele (Till et al. 2007).

#### **IV Genomics-based Approaches for Understanding the Response of Plants Towards Abiotic Stresses**

It has now been clearly established that abiotic stress response is a complex trait governed by multiple genes. During the last 15 years, basic biological research has undergone a major revolution with the main endeavors of scientific research being switched from studying the expression of single genes or proteins to focusing on a large number of genes or gene products simultaneously, enabling genome-wide expression strategies for better understanding of these complex traits. During the first part of the genomics era, researchers

concentrated on accumulating DNA sequence information from a range of model plants, as well as those having economic importance. The first complete genome sequence of a plant, *Arabidopsis thaliana*, was reported in the year 2000 ([www.arabidopsis.org](http://www.arabidopsis.org)). This dicot flowering plant is an important model system for identifying genes and determining their functions. Similarly, the complete genome sequence for rice, one of the world's most important food crops, was reported in the year 2005 (International Rice Genome Sequencing Project 2005; <http://rgp.dna.affrc.go.jp/IRGSP/>). Rice, the model plant for the poaceae family, has important syntenic relationships with the other cereal species (<http://www.gramene.org>). A total of 37,544 non-transposable-element-related protein-coding genes have been identified, out of which 71% have a putative homologue in *Arabidopsis*. Interestingly, 29% of the predicted genes in rice appear in clustered gene families. This suggests the existence of a possible 'regulon' operating in rice, similar to what has been already reported in *Arabidopsis* (Ma and Bohnert 2008). Similarly, the map-based sequence of rice has proven useful for the identification of genes underlying the various agronomic traits. The identification of additional single-nucleotide polymorphisms and simple sequence repeats should accelerate our understanding of stress response in rice.

Since, genomics information has become available for a broad range of organisms, an era has arisen in which the data generated can be used as a resource to answer many biological problems, which may thus provide rapid systematic ways to identify genes for crop improvement. Deriving meaningful knowledge from DNA sequences will define biological research through the coming decades and require the expertise of biologists, chemists, engineers and computational scientists, amongst others. With the whole genome sequences in hand, some research challenges for the future that need to be taken up include – studies on determination of gene number, their exact locations and functions; gene regulation; coordination of gene expression, protein synthesis and post-translational events; interaction of proteins; correlation of single nucleotide polymorphisms (SNPs) (i.e., single-base DNA variations among individuals) with agronomically important traits and their prediction based on gene sequence variation.

High throughput technologies have proven to be extremely useful in addressing the complexities related to gene regulation in plants. These advancements include technologies available for the studies targeting the quantitative trait loci (QTL) analysis, transcript kinetics and proteomics, as well as post-translational modifications. In the next section, we present details for some of these advancements which have enabled us to comment on abiotic stresses in a system biology approach.

#### A Identification of QTLs for Tolerance to Abiotic Stresses

The availability of both *Arabidopsis* and rice genome sequences has led to the identification of thousands of molecular markers, making map-based cloning a viable option for global functional genomics (Jander et al. 2002). The QTL mapping approach has been employed to dissect QTLs controlling the highly complex abiotic-stress tolerance traits. Several QTLs involved in the stress response have been recently reported (Zheng et al. 2003; Lin et al. 2004; Ren et al. 2005; Salvi and Tuberosa 2005). Most of these QTLs have been identified using the positional cloning approach. This strategy allows the use of a phenotype to determine the position of an allele by examining linkage of markers, whose position in the genome is already known. Employing an F2 population, derived from a cross between a salt-tolerant *indica* variety (Nona Bokra) and a susceptible *japonica* variety (Koshihikari), ten QTLs responsible for variation in K<sup>+</sup> and Na<sup>+</sup> content were identified in rice (Lin et al. 2004). One of these QTLs, *SALTOL*, located on the short arm of chromosome 1 was found to explain 40% of the variation in salinity tolerance. High resolution mapping of backcross populations, led to the identification of *SKC1* gene and it was found to code for an HKT-type transporter (Ren et al. 2005).

Submergence of rice (*Oryza sativa*) by flash flooding is a major constraint to rice production in coastal areas. Rice cultivars vary in their capacity to tolerate complete submergence and quantitative trait loci analysis has revealed that a large portion of this variation in submergence tolerance can be explained by just one locus (*Sub1*) on chromosome 9. Two published reports (Xu et al. 2006;

Fukao et al. 2008) suggest that a transcription factor, belonging to the B-2 subgroup of the ethylene response factors (ERFs)/ethylene-responsive element binding proteins (EREBPs)/apetala 2-like proteins (AP2), located within the *Sub1* locus determines submergence tolerance in rice. These genes control highly conserved hormonal, physiological and developmental processes that determine the rate of elongation of the plants when submerged.

#### B Analysis of Transcript Profiles: Transcriptomics

All living organisms have thousands of unique genes encoded in their genome, of which only a small fraction, perhaps 15%, are expressed in any individual cell. Therefore, it is the temporal and spatial regulation in gene expression that determines life processes. Thus, expression profiling has become an important tool to investigate how an organism responds to environmental changes. Plants, being sessile, have the ability to alter their gene expression patterns in response to environmental changes such as temperature, water availability or the presence of deleterious levels of ions, both low and high (Hazen et al. 2003). Sometimes, these transcriptional changes are successful adaptations leading to tolerance, while at other times, the plant ultimately fails to adapt to the new environment and is considered to be sensitive to that condition. Expression profiling can define both tolerant and sensitive responses (Fig. 3). These profiles of plant responses to environmental extremes are expected to lead us to the identification of regulators that will be useful in biotechnological approaches being used to improve stress tolerance, as well as to new tools for studying regulatory genetic circuitry (Pareek et al. 2007).

Certain high-throughput techniques have been employed to identify the gene whose expression at the transcript level is differentially regulated in response to various environmental stresses in higher plants. Such methods (for technical details of these methods, see Text Box 9.2) include differential display polymerase chain reaction (DDPCR), suppression subtractive hybridization (SSH), serial analysis of gene expression (SAGE), DNA-chip, microarray and cDNA-amplified fragment length polymorphism



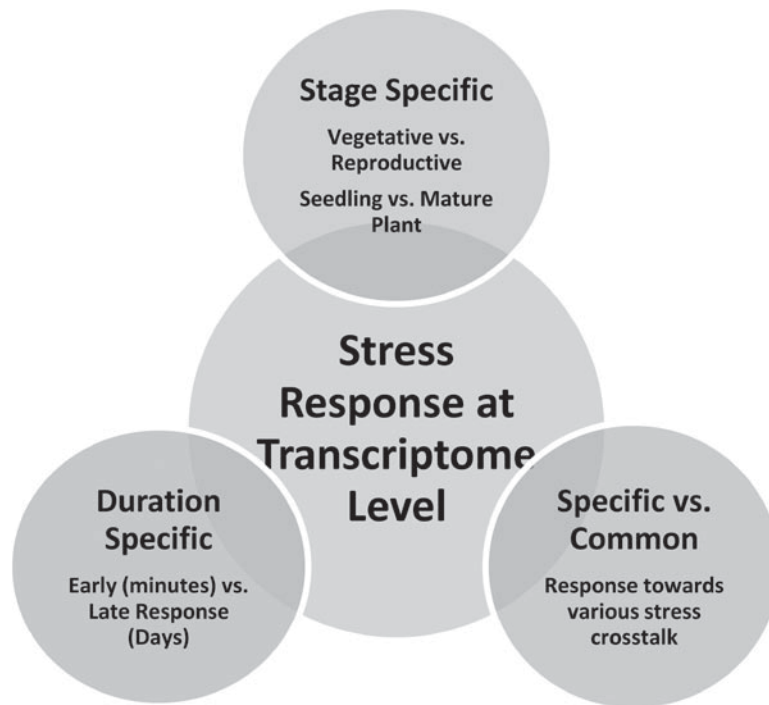

*Fig. 3.* Stress response at transcriptome level. Transcript profile changes during developmental stages of plants and also by the duration of applied stress. Expressions of some genes are specific at a particular stage, while some gene expressions are common during different stages of growth and duration of stress.

### Box 9.2 Recent Techniques Being Used for Analysis of Stress Response in Plants

#### *Transcriptomics*

Transcriptomics is often considered as a step next to genomics in the study of biological systems. The transcriptome is the set of all mRNA molecules, or “transcripts”, produced in one organism or cell type under a given set of conditions. It is more complex than genomics, mostly because an organism’s genome is rather constant (with the exception of mutations), while a transcriptome differs from cell to cell and constantly changes with changing external environmental conditions. Thus, the transcriptome reflects the genes that are being actively expressed at any given time, with the exception of mRNA degradation phenomena such as transcriptional attenuation.

#### *Differential Display PCR*

Different primer combinations (oligo-dTplus primers-T12NA, T12NT, T12NG or T12NC)

are used in a reverse transcriptase RT-PCR to generate cDNAs, from mRNAs expressed in a given cell. By comparing the cDNAs derived from multiple cell types, or from a single cell type under different conditions, it is possible to detect differences in transcription products derived from these diverse conditions. These differentially expressed products are identified on an acrylamide gel, excised, eluted, re-amplified and eventually sequenced.

#### *cDNA AFLP*

The cDNA-AFLP is a RNA finger printing technique used to analyze genes that are differentially expressed in genotypes with contrasting stress tolerance, grown under normal and stress conditions. Here, the double stranded cDNA is digested with two restriction enzymes, adapter molecules are ligated to the cDNAs and PCR amplification is performed with a primer that is complementary to the adapter, but has an additional one to three selective bases.

(continued)

**Box 9.2 (continued)***Subtractive Hybridization*

Suppression subtractive hybridization (SSH) has been a powerful approach to identify and isolate cDNAs of differentially expressed genes. It involves hybridization of cDNA from one population (tester) to an excess of mRNA (cDNA) from another population (driver) and then the separation of the unhybridized fraction (target) from hybridized common sequences is performed, followed by their cloning in a desired vector to generate a subtractive library. These subtraction techniques often involve multiple or repeated subtraction steps and are labor intensive (Diatchenko et al. 1996).

*Microarray*

The DNA chip technology has revolutionized the study of gene expression profiles (Schena et al. 1995) by allowing the entire gene complement of the genome to be studied in a single experiment. This technique makes use of microscopic slides on which specific DNA fragments [cDNA clones, EST clones, anonymous genomic clones or DNA amplified from open reading frames (ORFs)], determined from a database, have been printed at indexed positions using a computer controlled high speed robot.

*SAGE*

This technique was invented to quantify gene expression in yeast (Velculescu et al. 1995) and comprises the production of a short 10–14 nucleotide tag, with each tag representing a unique transcript present in a cell (all possible combination of four bases in a 10 bp sequence, 4<sup>10</sup> gives more than 1 million different sequences). Determination of a tag sequence allows the identification of the corresponding gene, and the frequency of a tag represents the steady state level of the mRNA from which it was derived. The unique advantages of SAGE over alternative techniques for transcript analysis are: high sensitivity; threshold detection of one transcript in three cells (Ishii et al. 2000);

scalability; it can be used on any size of sample, from a few cells upwards; detection of all genes, including those of unknown function; avoidance of amplification bias; data obtained is digital and not derived (e.g., from an analogue fluorescent signal); data is immortal and can be used at any time in a comparative study; data sets generated by one lab can be related directly to those produced by another. To date, however, this technique has found limited utility in the field of plant research.

(cDNA-AFLP). However, genes identified, isolated and cloned by such approaches would need to be functionally-characterized.

### 1 Transcriptome Analysis using High-Throughput Techniques

#### 1.1 Differential Display PCR

Liu and Baird (2003) isolated 17 cDNA clones from sunflower by means of DD-PCR and the genes corresponding to 13 of these cDNAs were confirmed by quantitative RT-PCR, to be expressed differentially in response to osmotic stress. Their expression patterns were further analyzed in leaves of drought-stressed plants, and in roots and shoots of drought- or salinity- stressed seedlings (Liu and Baird 2003).

#### 1.2 cDNA-Amplified Fragment Length Polymorphism (AFLP)

The cDNA-AFLP technique was used to analyze differentially expressed genes in wheat RH8706-49, a salt-stress resistant line (SR) and H8706-34, a salt-stress sensitive line (SS), with or without NaCl stress. A large number of gene fragments related to salt stress were found. Among them, a cDNA encoding glycogen synthase kinase-shaggy kinase (TaGSK1) was shown to be induced by NaCl stress and expressed more strongly in SR than in SS, suggesting that TaGSK1 is involved in its response to salt stress as a part of the signal transduction component (Chen et al. 2003). This technique has also been used to isolate differentially expressed ESTs during cold acclimatization in *Physcomitrella patens* (Sun et al. 2007), drought

responses in *Festuca mairei* (Wang and Bughrara 2007), water-stress tolerance in wild barley (Suprunova et al. 2007), salinity stress in soybean (Aoki et al. 2005) and potato (Hmida-Sayari et al. 2005).

### 1.3 Subtractive Hybridization

A PCR-based subtraction method has been employed for isolation and expression analysis of salt stress-associated ESTs from contrasting rice cultivars (Sahi et al. 2003; Kumari et al. 2009). In order to understand the gene expression patterns and isolate drought induced cDNAs from maize, a subtractive cDNA library was constructed from PEG-treated maize seedlings (Jia et al. 2006). Suppression subtractive hybridization was carried out to identify early salt stress responsive genes in tomato root (Ouyang et al. 2007). This approach has also been employed for studying long-term transcript accumulation during development of dehydration adaptation in *Cicer arietinum* (Boominathan et al. 2004).

### 1.4 Microarray

Gene expression profiling using cDNA microarrays or gene chips is a useful approach for analyzing the expression patterns of genes under abiotic stress conditions of drought, cold and high salinity. The use of microarray to study global gene expression profiling in response to abiotic stress in rice was first reported by Kawasaki et al. (2001). Global gene expression analysis of rice in response to drought and high-salinity stresses in shoot, flag leaf and panicle, has also been performed using microarray (Zhou et al. 2007). Genome-wide transcriptional analysis of salinity stressed rice genotypes, during vegetative and panicle initiation stage, has also been carried out using microarrays (Walia et al. 2005, 2007). Despite the advantage of this precise technique, several problems have arisen and are expected to be resolved in the near future. These include the high cost and identification of appropriate software for analysis of results and standardization of methods to allow comparison between results from different laboratories (Van Hal et al. 2000; Richmond and Somerville 2000).

### 1.5 Serial Analysis of Gene Expression (SAGE)

Among the various techniques used to assess transcript abundance, the most powerful is probably

SAGE. Serial analysis of gene expression was used to profile transcript levels in *Arabidopsis* roots and assess their responses to 2,4,6-trinitrotoluene (TNT) exposure. SAGE libraries representing transcripts from control and TNT-exposed seedlings were constructed, and each was sequenced to a depth of roughly 32,000 tags. More than 19,000 unique tags were identified overall. The second most highly induced tag (showing a 27-fold increase) represented a glutathione S-transferase. Cytochrome P450 enzymes, as well as an ABC transporter and a probable nitroreductase, were highly induced by TNT exposure. Analyses also revealed an oxidative stress response upon TNT exposure (Ekman et al. 2003). The SAGE technology has also been employed to reveal changes in gene expression, in case of *Arabidopsis* leaves and pollen undergoing cold stress (Lee et al. 2001; Jung et al. 2003).

## 2 Transcriptional Profiling Reveals That Metabolic Re-Adjustment is a Hallmark of Abiotic Stress Response

The metabolic readjustment in response to abiotic stress is brought about by a cascade of events, involving perception and transduction of stress signals through a chain of signaling molecules that ultimately affect regulatory elements of stress inducible genes. These signaling molecules further initiate the synthesis of different classes of proteins called effectors which alter the activity of various stress responsive genes and include transcription factors, enzymes, molecular chaperons, ion channels, transporters and scavengers of ROS. Over the last decade, *FunCat* has been established as a robust and stable annotation scheme that offers both meaningful and manageable functional classification of the extensive transcriptome data generated using genome wide approaches. The *FunCat* annotation scheme consists of 28 main categories (Ruepp et al. 2004). These include metabolism, energy, storage protein, cell cycle and DNA processing, transcription, protein synthesis, protein fate, protein with binding function or cofactor requirement, regulation of metabolism and protein function, cellular transport, cellular communication/signal transduction mechanism, cell rescue, defense and virulence, interaction (including systemic) with the environment, transposable elements,

viral and plasmid proteins, cell fate, development (systemic), biogenesis of cellular components, cell type differentiation, tissue differentiation, organ differentiation, subcellular localization, cell type localization, tissue localization, organ localization, classification (not yet clear-cut) and unclassified proteins. A comparative account of various studies, involving genome-wide transcriptome analyses of various abiotic stress responses in plants, indicate that unknown genes form the largest category (upto 30–40%), followed by genes required for metabolism (15%), cell rescue and defense (10%), protein synthesis (10%), signal transduction and cellular communication (8–10%), while those belonging to other functional categories constituted less than 5% of the total transcripts (Table 1).

### 2.1 Kinetics of Gene Expression Pattern: Early versus Late Responses

Plant tolerance towards abiotic stresses is a complex trait controlled by several genes and factors, some of which are induced within 15 min of stress imposition. Although these fast responding genes are few in number, they are critical

for transcriptome reprogramming under abiotic stresses. An instantaneous response (within 15 min) was detected for only 2% of the genes in Pokkali (salt tolerant wild variety of rice), including genes responsible for production of glucose-regulated proteins (GRPs) and calcium dependent protein kinases (CDPKs) (Kawasaki et al. 2001). In another study, it was reported that the early response genes mainly belonged to two functional categories, that is, cellular communication/signal transduction and transcription. The transcription factor (TF)-related factors induced a calmodulin-binding transcription factor, a plant homeo domain (PHD)-finger, a zinc finger, a NAM, ATAF and CUC (NAC) transcription factor and other DNA binding proteins. The cellular communication/signal transduction included kinases such as OsCDPK7 (a positive regulator commonly involved in the tolerance to cold, salt and drought) and some new stress induced kinases (Chao et al. 2005).

An adaptive response of plants to salinity stress is induced after 3–24 h of NaCl stress in rice. This response includes three aspects: ion homeostasis, damage control and growth regulation. At the gene

Table 1. Functional characterization of various stress responsive genes of different plant species (in percent).

Category	Rice (Kumari et al. 2009)	<i>Arabidopsis</i> (Popova et al. 2008)	Grape (Waters et al. 2005)		Maize (Jinping et al. 2006)	Mangrove (Miyama and Hanagata 2007)	Tomato (Ouyang et al. 2007)
	Salt	Salt	Salt	Drought	Drought	Salt	Salt
Unclassified+unknown	31	34.5	36	24	32	30	13
Developmental	1.3	–	1	1	–	–	–
Metabolism	14	20.4	20	15	41	17	25
Energy	13	–	3	2	–	–	6
Transcription	4	3.4	8	6	8	10	23
Cell rescue & defense	6	9	9	8	–	10	6
Cellular communication & signal transduction	4	7.9	6	4	3	8	6
Cellular transport	5	9	6	4	–	9	6
Interaction with environment	1	–	5	5	5	–	2
Protein fate	7	3.4	7	–	–	5	4
Protein synthesis	8	8.5	2	4	8	5	1
Protein with binding function	2	–	3	2	–	–	6
Subcellular- localization	–	–	4	3	–	–	2
Biogenesis of cellular component	0.2	–	–	–	–	1	–
Cell cycle & DNA processing	2	–	4	3	3	–	–
Transposons	5	–	0.1	0.1	–	0.4	–



expression level, these factors are controlled by regulation of genes belonging to four functional categories: cellular transport, cellular rescue and defense, energy and metabolism. After 1 h salt stress treatment, upregulation was detected for 33% of the genes in rice (Kawasaki et al. 2001), which largely included genes involved in protein synthesis (such as ribosomal proteins, elongation factors) and protein modifications (such as protease inhibitors which may be involved in restructuring of protein synthesis apparatus). The genes, which were upregulated within 3–6 h of stress, consisted of those involved in growth such as sucrose synthase 2 and those involved in hormonal induction such as  $\beta$ -glucosidases. Upregulation of the genes involved in defense against ROS, such as glutathione-S-transferase (GST) and ascorbate peroxidase (APX), dominated the transcripts induced 24 h after stress imposition. Study by Chao et al. (2005) showed rapid induction in cell rescue and defense genes in this category, with 76.5% of the genes being upregulated. This rapid response is vital to salt tolerance because high salt can lead to stress damage that quickly becomes irreversible. These genes function in every aspect of damage control or repair, playing important roles in removal of ROS and other stress induced toxins, repair of protein and DNA, protection against enzyme activity and maintenance of osmotic homeostasis. These include antioxidant enzymes (such as glutathione reductase, dehydroascorbate reductase, glutathione peroxidase, enzymes functioning in repair (including heat shock proteins such as DNAJ and Clp proteases), and enzymes maintaining osmotic homeostasis (LEA and trehalose synthesis enzymes). Induction of cellular transport genes is related to ion-homeostasis. Many genes involved in protein degradation, such as proteases, were also induced as an adaptive response to salinity stress.

A rapid down-regulation was observed in photosynthesis and metabolism related genes, reflecting growth inhibition observed in salt stressed plants. Many of these genes encode enzymes that catalyze carbohydrate metabolism, whose down-regulation can contribute to accumulation of protective osmolytes or inhibition of destructive foldases and proteases. A downregulation of the genes involved in biosynthesis and nitrogen fixation was also detected in tomato within 2 h of

salinity stress (Ouyang et al. 2007). Only a few genes showed an increased expression after 7 days of stress, including metallothioneins (Kawasaki et al. 2001; Chao et al. 2005).

A comparison of the early and late response transcripts was conducted for drought stress induced maize seedlings (Zheng et al. 2004). The highly upregulated clones at early time points (0.5 to 1) included dehydration responsive element (DRE) binding factor, protein kinase, protein phosphatase 2C, nucleic acid binding protein, WD domain containing protein, while the late induced transcripts (2–6 h) consisted of GST, ribosomal proteins and glutaredoxin.

## 2.2 Kinetics of Gene Expression Patterns: Developmental Stage/Organ-specific Regulation

Sensitivity of crops to abiotic stresses varies with the growth stage as well. In general, rice plants are highly sensitive to salinity stress at young seedling stages (Flowers and Yeo 1981). From an agronomic point of view, tiller number and number of spikelets per panicle have been reported to be the most salinity sensitive yield components. These components are determined at vegetative and panicle initiation stages, respectively. Centroradialis (CEN), a gene which plays a role in phase transition and panicle morphology, was induced in both the sensitive genotypes, M103 and IR29, in response to salinity (Walia et al. 2005, 2007). One of the most striking stress responses of IR29 during the vegetative stage experiment was the induction of genes involved in the flavonoid pathway which include those encoding for phenylalanine ammonia lyase, chalcone synthase, dihydroflavonol 4-reductase and flavonone 3-hydroxylase. Therefore, up-regulation of the flavonoid pathway, as a response to salinity stress, appears to be a general characteristic of IR29. Rice is more susceptible to damage caused by water deficit at particular growth stage. A given level of drought at the vegetative stage can cause a moderate reduction in yield, but the same stress can eliminate yield entirely if it coincides with pollen meiosis or fertilization (O'Toole and Baldia 1982). The degree of overlap in the expression of stress responsive genes in various rice organs viz flag leaf, panicle and shoot (four-leaf vegetative stage) was studied (Zhou et al. 2007). Limited degree of overlap was detected with only a small number of gene expression

patterns being shared between a pair of organs. The greatest overlap was observed between root and flag leaf under both high salinity and drought conditions. Interestingly, transcription factor genes under these conditions were expressed in an organ-specific manner. Among the 186 induced transcription factor genes, only 12 were found to be expressed in all the three organs following drought or salinity stress.

### 2.3 Cross Talk between Various Abiotic Stress Responses

Based on microarray analysis, Rabbani et al. (2003) identified 36, 62, 57, and 43 genes induced by cold, drought, high salinity and abscisic acid (ABA), respectively, in rice. Fifty-six genes were induced by both drought and high salinity, 25 genes were induced by both drought and cold stress and 22 genes were induced by both cold and high salinity stress. Similarly, 43 genes were up-regulated by both drought and ABA application, whereas only 17 genes were identified as cold- and ABA-inducible genes. More than 98% of the high salinity- and 100% of ABA-inducible genes were also induced by drought stress, which indicates a strong relationship not only between drought and high-salinity responses, but also between drought and ABA responses. These results indicate a greater cross-talk between drought and high salinity stress, as well as between drought and ABA signaling as compared to that between cold and high salinity stress or between cold and ABA signaling. Similar observations were made in *Arabidopsis*, where an overlap was also detected between drought and high salinity responsive gene expression (Shinozaki and Yamaguchi-Shinozaki 1999; Seki et al. 2002). However, contradictory observations were made by Kreps et al. (2002) in cold and high salinity stressed *Arabidopsis* and by Ozturk et al. (2002) in drought and high salinity stressed barley (*Hordeum vulgare*). A comparison between the two abiotic stresses, that is, high salinity and drought, was also carried out in various organs of rice (Zhou et al. 2007). It was observed that almost half of the genes upregulated or down-regulated by drought stress also exhibited a similar expression pattern under high salinity. The remainder of drought responsive genes exhibited different expression patterns under high salinity. The genes specifically induced by drought

stress include DREB1A, LEA protein, WS176, MAP65, no apical meristem (NAM), helix-loop-helix (HLH), G-box binding, zinc finger, activator protein-2 (AP2) transcription factors and some kinases.

### C Large Scale Study of Proteins: Proteomics

The transcriptome analyses of gene expression at the mRNA level have greatly contributed to our understanding of abiotic stress responses in model plants such as *Arabidopsis* and rice. However, the level of mRNA does not always correlate well with level of protein, the key player in the cell. The level of transcription of a gene gives only an approximate estimate of its level of expression into a protein. An mRNA produced in abundance may be degraded rapidly or translated inefficiently, resulting in still lower abundance of protein.

Recent studies have indicated that out of a given pool of mRNA, only a fraction is recruited further into the polyribosome assembly for translation (Bailey-Serres 1999). It is intriguing to study what factors are responsible for this differential recruitment of mRNA into the translational assembly. Many proteins experience post-translational modifications that profoundly affect their activities, for example, some proteins are not active until they become phosphorylated. Methods such as phosphoproteomics and glycoproteomics are used to study post-translational modifications. Further, many transcripts give rise to more than one protein, through alternative splicing or alternative post-translational modifications.

The study of tobacco leaf apoplast proteome, in response to salt stress, identified 20 proteins whose expression changed in response to stress. These included several well-known stress-associated proteins, together with chitinases, germin-like proteins and lipid transfer proteins (Dani et al. 2005). Proteome analysis was performed to study the effect of cold stress on rice anthers at the young microspore stage. Of the total 3,000 proteins, 70 showed differential expression in response to cold stress and 7 of the 18 proteins identified by matrix assisted laser desorption-ionization time of flight mass spectrometry (MALDI-TOF-MS), were observed to be partially degraded, reflecting

the effect of cold stress at the young microspore stage (Imin et al. 2006). Similarly, in an analysis of the rice cold stress proteome, proteins from unstressed seedlings were compared with those from seedlings exposed to temperatures of 15°C, 10°C, and 5°C. Of a total 1,700 protein spots separated by two-dimensional gel electrophoresis (2-DE), 60 proteins were up-regulated due to a decrease in temperature. The identities of 41 of these proteins were established by MALDI-TOF-MS or electrospray ionization tandem mass spectrometry (ESI/MS/MS) and these mainly included chaperones, proteases, detoxifying enzymes and enzymes linked to cell wall biosynthesis, energy pathways and signal transduction. These results emphasize the importance of maintaining protein quality control via chaperones and proteases, together with an increase in cell wall components during the cold stress response (Cui et al. 2005). In addition, a rice proteome database is available, which catalogues information from 23 reference maps of 2-DE analysis of proteins obtained from diverse biological samples. The database contains, in total, 13,129 identified proteins and amino acid sequences of 5,092 proteins (Komatsu 2005).

Protein phosphorylation plays a key role in the process of signal transduction in cells. Since phosphoproteins are present in low abundance, either radiolabeling or enrichment methods are required for their analysis (For a review on technological advancements in the area of phosphoproteomics, see Nita-Lazar et al. 2008). Proteomics approach has been employed to identify the phosphoproteome in rice and *Arabidopsis* (Khan et al. 2005; Kwon et al. 2007). Phosphoproteome in rice was detected by in vitro protein phosphorylation, achieved by incubating the crude protein extract with [ $\gamma$ - $^{32}$ P] ATP followed by 2-DE. Forty-four phosphoproteins were identified by quadrupole time-of-flight mass spectrometer (Q-TOF MS/MS) and MADLI-TOF MS. Amongst these, the largest percentage was involved in signaling (30%). Thirteen of these proteins were regulated differentially by various hormones and stress treatments. In another study, the phosphoproteome of *Arabidopsis* was identified using the enrichment methods. A strategy that replaces the phosphate moieties on serine and threonine residues with a biotin-containing tag, via a series of chemical reactions, was employed.

Ribulose 1,5-bis-phosphate carboxylase/oxygenase (RUBISCO)-depleted protein extracts, prepared from *Arabidopsis* seedlings, were chemically modified for 'biotin-tagging'. The biotinylated (previously phosphorylated) proteins were then selectively isolated by avidin-biotin affinity chromatography, followed by two-dimensional gel electrophoresis (2-DE) and MALDI-TOF MS. This led to the identification of 31 protein spots, representing 18 different proteins, which are implicated in a variety of cellular processes.

In order to gain a better understanding of dehydration response in the food legume, chickpea (*Cicer arietinum* L.), a comparative nuclear proteome analysis was carried out (Pandey et al. 2007). Approximately, 205 protein spots were found to be differentially regulated under dehydration. Mass spectrometry analysis allowed the identification of 147 differentially expressed proteins, presumably involved in a variety of functions including gene transcription and replication, molecular chaperones, cell signaling and chromatin remodeling. In plants, cell wall or extracellular matrix (ECM) serves as the repository for most of the components of the cell signaling process and acts as a frontline defense mechanism. A proteomics approach was employed to identify dehydration-responsive ECM proteins in chickpea (Bhushan et al. 2007). The comparative proteomic analysis led to the identification of 134 differentially expressed proteins that include predicted and novel dehydration-responsive proteins.

### Box 9.3 Tools of Proteomics

Research in proteomics requires resolving proteins on a massive scale. Protein separation can be performed using two-dimensional gel electrophoresis, which usually separates proteins first on the basis of their isoelectric points and then by their molecular weights. Protein spots in a gel can be visualized using a variety of chemical stains or fluorescent markers. Proteins can often be quantified by the intensity of their stain. Once proteins are separated and quantified, they are identified. Individual spots are cut out of the gel and cleaved into peptides

(continued)

**Box 9.3 (continued)**

with proteolytic enzymes. These peptides can then be identified by mass spectrometry, specifically matrix-assisted laser desorption-ionization time-of-flight (MALDI-TOF) mass spectrometry. In this procedure, a peptide is placed on a matrix, which causes it to form crystals. Then the peptide (on the matrix) is ionized with a laser beam and an increase in voltage at the matrix is used to shoot the ions towards a detector, in which the time taken by an ion to reach the detector is recorded as it depends on its mass. Higher the mass, longer the time of flight (TOF) of the ion. High-throughput proteomic techniques are based on mass spectrometry, commonly peptide mass fingerprinting on MALDI-TOF instruments or de novo repeat detection MS/MS on instruments capable of more than one round of mass spectrometry. MS/MS data can be analyzed by simple database searches as is the case for PMFs and additionally, they can be analyzed by de novo sequencing and homology searching in databases such as Mascot, PEAKS OMSSA or SEQUEST. This particular approach allows us to identify even similar (homolog) proteins, for example, across the species in case a protein was derived from an organism with unsequenced genome. Further, ICP-MS combined with MeCAT – metal coded tagging – technology is used for ultrasensitive quantification of proteins and peptides (down to low attomol range).

*Gas Chromatography*

Gas chromatography, in combination with mass spectrometry (GC-MS), is one of the most widely used and powerful methods. It offers very high chromatographic resolution, but requires chemical derivatization for many biomolecules, as only volatile chemicals can be analysed without derivatization. Some large and polar metabolites cannot be analyzed by GC. Compared to GC, HPLC has lower chromatographic resolution, but it does have the advantage that a much wider range of analytes can be potentially measured. Capillary electrophoresis (CE), though less popular than other

techniques, has a higher theoretical separation efficiency than HPLC, and is suitable for use with a wider range of metabolite classes than GC. As for all electrophoretic techniques, it is most appropriate for charged analytes. GC-MS is the most popular combination of the three, and was the first to be developed.

*Nuclear Magnetic Resonance (NMR) Spectroscopy*

It is the only detection technique which does not rely on separation of the analytes, and the sample can thus be recovered for further analyses. All kinds of small molecule metabolites can be measured simultaneously. Practically, however, it is relatively insensitive compared to mass spectrometry-based techniques. Additionally, NMR spectra can be very difficult to interpret for complex mixtures.

*Yeast Two Hybrid System*

The principle of yeast two hybrid system is that a functional transcription factor consists of two different domains: a DNA binding domain (DBD) and a transactivation domain (AD). In the yeast two hybrid system, these two domains are separated and each one is fused to a protein of interest (X and Y, respectively). Physical interaction between DBD-X and AD-Y reconstitutes a transcription factor that can activate the transcription of reporter genes regulated by DBD binding sites.

Since the signaling processes in plants, that initiate cellular responses to abiotic stresses, are believed to be located in the plasma membrane, a sub-cellular proteomics approach was applied to monitor changes in the abundance of plasma membrane-associated proteins in response to salinity stress (Malakshah et al. 2007). The details about the various tools of proteomics are discussed in Text Box 9.3.



## D Metabolomics

The metabolome represents the collection of all metabolites in a biological organism, which are the end products of its gene expression. Thus, while mRNA gene expression data and proteomic analyses do not tell the whole story of what might be happening in a cell, metabolic profiling can give an instantaneous snapshot of the physiology of the cell. The word was coined in analogy with transcriptomics and proteomics as like the transcriptome and the proteome, the metabolome is dynamic, that is, changing from second to second. Although the metabolome can be defined readily enough, it is not currently possible to analyze the entire range of metabolites by a single analytical method. Recent technological advances in mass spectrometry have made possible reliable and highly sensitive measurements of metabolites. A wide range of analytical technologies are now available for the analysis of metabolites.

Metabolomics has been utilized not only to investigate plant metabolism but also to identify unknown gene functions by comparing the profiles between wild-type and genetically altered plants or during developmental changes. The popular metabolomics strategy is to focus on the pattern of metabolite concentrations under a given set of conditions. Such quantitative information on metabolites has been used to either predict gene functions directly involved in metabolic processes or to delineate metabolism and its regulatory networks or to distinguish metabolic phenotypes. Metabolomics is now finding use in the analysis of plants perturbed by abiotic changes. In one such study, metabolite profiling was employed to characterize the freezing tolerance response of *A. thaliana* and understand the function of the cold-response regulatory pathway that is regulated by the CBF transcription factor family. This study showed that the physiological process of cold acclimation significantly influenced the concentration of three-quarters of the >400 metabolite peaks that were detected by gas-chromatograph mass spectrometry (GC-TOF-MS) and that the levels of most of these peaks were influenced by (CBF)-mediated cold response pathway (Cook et al. 2004).

## V Interactome

Proteins are actual molecular entities required for most of the biological processes inside the cell. Proteins function by interacting with other bio-molecules like other proteins, lipids, nucleic acids and several low molecular weight compounds. Biochemical activity inside the cell is mostly carried out by formation of transient or stable protein complexes. It has been found that smaller the number of genes and proteins, less complex is an individual and to make a more complex multicellular organism, there must be complex interactions among the various proteins (Bird 1995; Szathmary et al. 2001; Rubin 2001). Therefore, a comprehensive knowledge of protein interactions is an important source of information to understand the cellular processes on a genome wide level. The collection of all protein interactions in an organism is typically referred to as an interactome (Magdalena 2005). One of the major goals in the post genomic era is to analyze the complete protein linkage map, that is, interactome of an organism, to understand the signaling pathways operative inside the cell, which help it in responding and adapting to the fluctuating environmental conditions. Availability of a huge protein database, its expression and localization has led to the study and prediction of protein-protein interactions by bioinformaticians. These protein-protein interactions have been studied at three levels:

- Simple yeast two hybrid systems to identify the interacting partners
- Use of high throughput yeast two hybrid analysis by tandem affinity purification and tandem mass spectrometry
- Exploiting the available protein database to predict the protein-protein interactions

### A Interacting Partners of Two Component System

As an example, yeast two hybrid system has been used to find out interacting partners of the two component system of eukaryotes (Fig. 4). This signaling pathway involves the transfer of a phosphate group from ATP to the conserved histidine residue of histidine kinase; this phosphate group is further transferred to a conserved aspartate resi-

due of response protein in simple histidine kinase. In sensory hybrid type histidine kinase, the transfer of phosphate group from histidine kinase to response regulator is mediated by histidine-containing phosphotransfer protein (Grefen and Harter 2004). Recently, a detailed interactome map has been generated for the two-component signaling members of *Arabidopsis thaliana* which has given insight as to how TCS members may be operative under diverse signaling cascades in plants (Dortay et al. 2008).

### B High Throughput Yeast Two Hybrid Analysis

Several research projects have been initiated with the goal of comprehensively mapping the networks of protein–protein interactions in yeast and nematode worm (Walhout et al. 2000; Ito et al. 2000). This produced a huge interactome data by high throughput experiments. Mapping of protein–protein interactions using global approaches is a major thrust to understand biological processes of cellular organisms. The yeast two hybrid system is the technique that requires manipulation of DNA to search for

interacting partners. Basic information about large number of genes and gene products is available along with details about their expression, localization and interaction with other proteins. Therefore, to obtain global maps of expression, localization and interaction, the currently available methods need to be converted into standardized functional assays that should be amenable to automation. It will also help in understanding the function of unknown proteins by knowing their interaction with known proteins and by manipulating the DNA to decipher the pathways operative inside the cell. The first genomic analysis using the two-hybrid system was carried out from *Escherichia coli* bacteriophage T7 and a protein linkage map was created (Bartel et al. 1996).

Major challenge at present is to understand the roles of all the predicted ORFs, gene products and how they interact to create a eukaryotic organism. *Saccharomyces cereviceae* genome sequencing has predicted 6,144 ORF. In this direction, a comprehensive analysis of protein–protein interactions in *Saccharomyces cereviceae* was done by array screening (<http://depts.washington.edu./sfields/>) and library screening, by cloning 5,345 ORFs

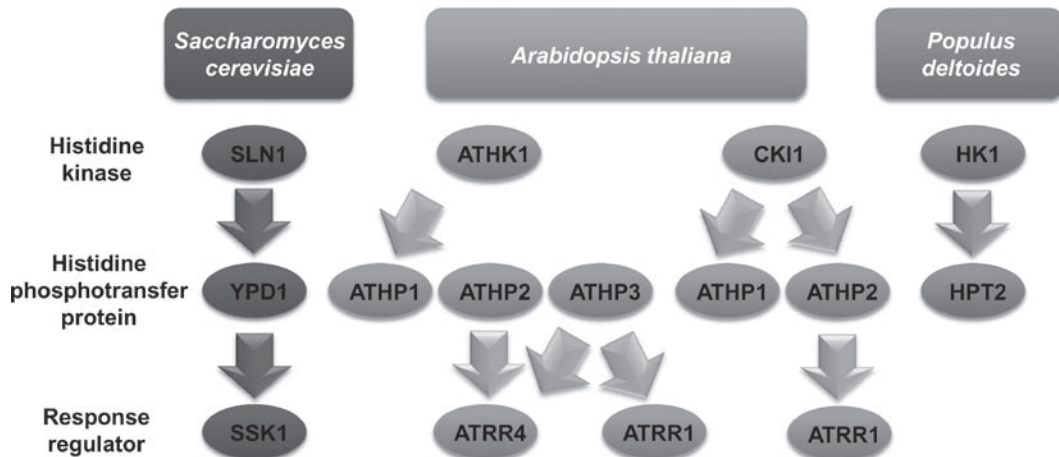

Fig. 4. Schematic representation of interacting partners of two component system. Histidine kinase interacts with histidine phosphotransfer protein, which further interacts with response regulator. In *Saccharomyces cereviceae* (Posas et al. 1996), histidine kinase (SLN1) interacts with histidine phosphotransfer protein (YPD1) and YPD1 interacts with response regulator (SSK1). In *Arabidopsis thaliana*, ATHK1 selectively interacts with ATHP1, not with ATHP2 and ATHP3, whereas ATHP2 and ATHP3 interact redundantly with ATRR4 (Urao et al. 2000). ATHP3 also interacts with ATRR1. In tree plant *Populus deltoides*, HK1 interacts with HPT2 (Chefdor et al. 2006).

out of 6,144 ORFs of *Saccharomyces cereviceae* (Uetz et al. 2000). This analysis revealed the categorization of some functionally unclassified proteins into a biological context. For example, YGR010W and YLR328W (77% identical), the two proteins of unknown function were observed to interact with each other. Both proteins also bind to ornithine amino transferase indicating that they may be involved in arginine metabolism. Data from this study also provided evidence for the link between two proteins involved in autophagy and cytoplasm-to-vacuole targeting (Cvt). Autophagy is a degradation pathway which operates under nutrient stress conditions to non-selectively recycle the cytoplasmic proteins and organelles to their constituent components. A large scale identification of interactions between integral membrane proteins of *Saccharomyces cereviceae* has been done where, among 705 annotated integral membrane proteins, 1,985 putative interactions have been identified by 536 proteins (Miller et al. 2005).

Protein–protein interactions are likely to play an important role in response to abiotic stress. It will help in understanding how cells perceive and transduce stress signals to trigger the genetic system responsible for appropriate plant response. There are a few studies on protein interaction mapping in plants. The interaction map of the *Arabidopsis thaliana*, MADS box transcription factors, has been developed to know the signal transduction cascade and it revealed regulatory loops, providing links between floral organ development and floral induction (DeFolter and Immink 2005). An interactive network of proteins associated with abiotic stress response and development in wheat (*Triticum aestivum*) has been generated (Tardif et al. 2007) using specific protein–protein interaction studies. The interaction comprises of 73 proteins, generating 97 interaction pairs and 21 of these interactions were confirmed by bimolecular fluorescent complementation in *Nicotiana benthamiana*. The interactome also revealed the presence of a “cluster of proteins involved in flowering control”, which gives an insight into the complex relationships among transcription factors known to play a central role in vernalization, flower initiation, abscisic acid signaling, as well as associations with regulatory and signaling proteins involved in abiotic stress.

### C Prediction of Protein–Protein Interactions Using Bioinformatics and Development of Protein Interactome Databases

The sequence based annotations have led to the identification of a number of cellular proteins and their localization inside the cellular compartments. Since, many proteins function by physically interacting with other proteins, proteins of unknown function can also be characterized by identifying the interacting partners within a large network of molecular interactions to understand the complex cellular functions of an organism. Interactomics is increasingly becoming a new tool to comprehensively deduce the network of protein–protein interactions, based on the available published protein–protein interaction literature. High throughput experiments have produced a large scale network of protein–protein interactions in yeast, fruitfly, nematode worm and human (Uetz et al. 2000; Giot et al. 2003; Li et al. 2004; Miller et al. 2005; Gandhi et al. 2006). An interactome of *Arabidopsis thaliana* has been developed by prediction from interacting orthologs in yeast, nematode worm, fruitfly and humans, using bioinformatics, where a total of 1,159 high confidence, 5,913 medium confidence and 12,907 low confidence interactions were identified for 3,617 conserved *Arabidopsis* proteins (Geisler-Lee et al. 2007). Similarly an *Arabidopsis thaliana* protein interaction database (AtPID) has been developed that integrates data from several bioinformatics prediction methods and manually collected information from literature (Cui et al. 2008). In this database, information about 28,062 protein–protein interactions have been included and information about their subcellular location, ortholog maps, domain attributes and gene regulation is also given (<http://atpid.biosino.org/>), which provides a rich source of information for system level understanding of gene function and biological processes in *Arabidopsis thaliana*. The dynamics of interactome network will be considered to address where and when interactions take place and how they are regulated.

## VI Future Prospects

The study of abiotic stress response in plants is not new, but as the newer tools and techniques

are being developed, we are witnessing more and more complexities in these responses. We have moved from an era of single gene analysis to genome level analysis tools. However, as it appears, we need to analyze these complexities brought in at the genome level, transcriptome level, translational level and recently, the interactome levels. Further, these analyses need to be viewed in tissue, time, dose and developmental windows. A wiser approach using a combination of above tools and technologies can pave our way towards understanding the stress response in plants, which at this moment seem to be very complex in nature.

### Acknowledgements

Authors would like to acknowledge the financial support received from Jawaharlal Nehru University, JNU (India), International Foundation of Science, IFS (Sweden), International Atomic Energy Agency, IAEA (Vienna), Department of Science and Technology, DST and Department of Biotechnology, DBT (Government of India). Ratna Karan acknowledges the award of Senior Research Fellowship, SRF from University Grants Commission, UGC (New Delhi, India).

### References

- Abe H, Urao T, Ito T, Seki M, Shinozaki K, Yamaguchi-Shinozaki Y (2003) *Arabidopsis* AtMYC2 (bHLH) and AtMYB2 (MYB) function as transcriptional activators in abscisic acid signaling. *Plant Cell* 15:63–78
- Aoki A, Kanegami A, Mihara M, Kojima T, Shiraiwa M, Takahara H (2005) Molecular cloning and characterization of a novel soybean gene encoding a leucine-zipper-like protein induced to salt stress. *Gene* 356:135–145
- Bailey-Serres J (1999) Selective translation of cytoplasmic mRNAs in plants. *Trends Plant Sci* 4:142–148
- Bartel PL, Roeklein JA, Sengupta D, Fields SA (1996) A protein linkage map of *Escherichia coli* bacteriophage T7. *Nat Genet* 12:72–77
- Bhushan D, Pandey A, Choudhary MK, Datta A, Chakraborty S, Chakraborty N (2007) Comparative proteomics analysis of differentially expressed proteins in chickpea extracellular matrix during dehydration stress. *Mol Cell Proteomic* 6:1868–1884
- Bird AP (1995) Gene number, noise reduction and biological complexity. *Trends Genet* 11:94–100
- Boominathan P, Shukla R, Kumar A, Manna D, Negi D, Verma PK, Chattopadhyay D (2004) Long term transcript accumulation during the development of dehydration adaptation in *Cicer arietinum*. *Plant Physiol* 135:1608–1620
- Boudsocq M, Lauriere C (2005) Osmotic signaling in plants: multiple pathways by emerging kinase families. *Plant Physiol* 138:1185–1194
- Chao DY, Lou YH, Shi M, Lou D, Lin HX (2005) Salt-responsive genes in rice revealed by cDNA microarray analysis. *Cell Res* 15:796–810
- Chefdor F, Be'ne'detti H, Depierreux C, Delmotte F, Morabito D, Carpin S (2006) Osmotic stress sensing in populus: components identification of a phosphorelay system. *FEBS Lett* 58:77–81
- Chen GP, Ma WS, Huang ZJ, Xu T, Xue YB, Shen YZ (2003) Isolation and characterization of TaGSK1 involved in wheat salt tolerance. *Plant Sci* 165:1369–1375
- Chinnusamy V, Schumaker K, Zhu JK (2004) Molecular genetic perspectives on cross-talk and specificity in abiotic stress signalling in plants. *J Exp Bot* 395:225–236
- Cook D, Flower S, Fiehn O, Thomashow MF (2004) A prominent role for the CBF cold response pathway in configuring the low temperature metabolome of *Arabidopsis*. *Proc Natl Acad Sci USA* 101:15243–15248
- Cui J, Li P, Li G, Xu F, Zhao C, Li Y, Yang Z, Wang G, Yu Q, Li Y, Shi T (2008) AtPID: *Arabidopsis thaliana* protein interactome database - an integrative platform for plant systems biology. *Nucleic Acids Res* 36:D999–D1008
- Cui S, Huang F, Wang J, Ma X, Cheng Y, Liu J (2005) A proteomic analysis of cold stress responses in rice seedlings. *Proteomics* 5:3162–3172
- Waters DL, Holton TA, Ablett EM, Lee LS, Henry RJ (2005) cDNA microarray analysis of developing grape (*Vitis vinifera* cv. Shiraz) berry skin. *Funct Integr Genomics* 5:40–58
- Dani V, Simon WJ, Duranti M, Croy RRD (2005) Changes in the tobacco leaf apoplast proteome in response to salt stress. *Proteomics* 5:737–745
- Defolter S, Immink RG (2005) Comprehensive interaction map of the *Arabidopsis* MADS box transcriptions. *Plant Cell* 17:1424–1433
- Diatchenko L, Lau YF, Campbell AP, Chenchik A, Moqadam F, Huang B, Lukyanov S, Lukyanov K, Gurskaya N, Sverdlov ED, Siebert PD (1996) Suppression subtractive hybridization: A method for generating differentially regulated or tissue-specific cDNA probes and libraries. *Proc Natl Acad Sci USA* 93:6025–6030
- Dortay H, Gruhn N, Pfeifer A, Schwerdtner M, Schmulling T, Heyl A (2008) Toward an interaction map of the two-component signaling pathway of *Arabidopsis thaliana*. *J Proteome Res* 7:3649–3660
- Eddy SF, Storey KB (2008) Comparative molecular physiological genomics: heterologous probing of cDNA arrays. *Methods Mol Biol* 410:81–110



- Ekman DR, Lorenz WW, Przybyla AE, Wolfe NL, Dean JFD (2003) SAGE analysis of transcriptome responses in *Arabidopsis* roots exposed to 2,4,6-trinitrotoluene. *Plant Physiol* 133:1397–1406
- Flowers TJ, Yeo AR (1981) Variability in the resistance of sodium chloride salinity within rice (*Oryza sativa* L.) varieties. *New Phytol* 88:363–373
- Fukao T, Harris T, Bailey-Serres J (2008) Evolutionary analysis of the Sub1 gene cluster that confers submergence tolerance to domesticated rice. *Ann Bot* 172:1–8
- Gandhi TK, Zhong J, Mathivanan S, Karthick L, Chandrika KN, Mohan SS, Sharma S, Pinkert S, Nagaraju S, Periaswamy B, Mishra G, Nandakumar K, Shen B, Deshpande N, Nayak R, Sarker M, Boeke JD, Parmigiani G, Schultz J, Bader JS, Pandey A (2006) Analysis of human protein interactome and comparison with yeast, worm and fly interaction datasets. *Nat Genet* 38:285–293
- Geisler-Lee J, O'Toole N, Ammar R, Provart NJ, Millar AH, Geisler M (2007) A predicted interactome for *Arabidopsis*. *Plant Physiol* 145: 317–329
- Giot L, Bader JS, Brouwer C, Chaudhuri A, Kuang B, Li Y, Hao YL, Ooi CE, Godwin B, Vitols E, Vijayadmodar G, Pochart P, Machineni H, Welsh M, Kong Y, Zerhusen B, Malcolm R, Varrone Z, Collis A, Minto M, Burgess S, McDaniel L, Stimpson E, Spriggs F, Williams J, Neurath K, Ioime N, Agee M, Voss E, Furtak K, Renzulli R, Aanensen N, Carrolla S, Bickelhaupt E, Lazovatsky Y, DaSilva A, Zhong J, Stanyon CA, Finley RL Jr, White KP, Braverman M, Jarvie T, Gold S, Leach M, Knight J, Shimkets RA, McKenna MP, Chant J, Rothberg JM (2003) A protein interaction map of *Drosophila melanogaster*. *Science* 302:1727–1736
- Grefen C, Harter K (2004) Plant two-component systems: principles, functions, complexity and cross talk. *Planta* 219:733–742
- Hazen SP, Wu Y, Kreps JA (2003) Gene expression profiling of plant responses to abiotic stresses. *Funct Integr Genomics* 3:105–111
- Hirochika H (2001) Contribution of the *Tos17* retrotransposon to rice functional genomics. *Curr Opin Plant Biol* 4:118–122
- Hmida-Sayari A, Costa A, Leone A, Jaoua S, Gargouri-Bouazid R (2005) Identification of salt stress-induced transcripts in potato leaves by cDNA-AFLP. *Mol Biotechnol* 30:31–40
- Imin N, Kerim T, Weinman JJ, Rolfe BG (2006) Low temperature treatment at the young microspore stage induces protein changes in rice anthers. *Mol Cell Proteomics* 5:274–292
- Inan G, Zhang Q, Li P, Wang Z, Cao Z, Zhang H, Zhang C, Quist TM, Goodwin SM, Zhu JK (2004) Salt cress: a halophyte and cryophyte *Arabidopsis* relative model system and its applicability to molecular genetic analyses of growth and development of extremophiles. *Plant Physiol* 135:1718–1737
- Ishii M, Hashimoto S, Tsutsumi S, Wada Y, Matsushima K, Kodama T, Aburatani H (2000) Direct comparison of GeneChip and SAGE on the quantitative accuracy in transcript profiling analysis. *Genomics* 68:136–143
- Ito T, Tashiro K, Muta S, Ozawa R, Chiba T, Nishizawa M, Yamamoto K, Kuhara S, Sakaki Y (2000) Toward a protein-protein interaction map of the budding yeast: a comprehensive system to examine two-hybrid interactions in all possible combinations between the yeast proteins. *Proc Natl Acad Sci USA* 97:1143–1147
- Jander G, Norris SR, Rounsley SD, Bush Df, Levin IM, Last RL (2002) *Arabidopsis* MAP based cloning in the post genome era. *Plant Physiol* 129:440–450
- Jia J, Fu J, Zheng J, Zhou X, Huai J, Wang J, Wang M, Zhang Y, Chen X, Zhang J, Zhao J, Su Z, Lv Y, Wang G (2006) Annotation and expression profile analysis of 2073 full-length cDNAs from stress-induced maize (*Zea mays* L.) seedlings. *Plant J* 48:710–727
- Jinping J, Fu J, Zheng J, Zhou X, Huai J, Wang J, Wang M, Zhang Y, Chen X, Zhang J, Zhao J, Su Z, Lv Y, Wang G (2006) Annotation and expression profile analysis of 2073 full-length cDNAs from stress-induced maize (*Zea mays* L.) seedlings. *Plant J* 48:710–727
- Jung SH, Lee JY, Lee DH (2003) Use of SAGE technology to reveal changes in gene expression in *Arabidopsis* leaves undergoing cold stress. *Plant Mol Biol* 52:553–567
- Karan R, Singla-Pareek SL, Pareek A (2009) Histidine kinase and response regulator genes as they relate to salinity tolerance in rice. *Funct Integr Genomics*. doi:10.1007/s10142-009-0119-x
- Kawasaki S, Borchert C, Deyholos M, Wang H, Brazille S, Kawai K, Galbraith D, Bohnert HJ (2001) Gene expression profiles during the initial phase of salt stress in rice. *Plant Cell* 13:889–905
- Kenji H, Saito M, Matsuoka H, Iida K, Iida H (2004) Functional analysis of a rice putative voltage-dependent Ca<sup>2+</sup> channel, OsTPC1, expressed in yeast cells lacking its homologous gene CCH1. *Plant Cell Physiol* 45:496–500
- Khan M, Takasaki H, Komatsu S (2005) Comprehensive phosphoproteome analysis in rice and identification of phosphoproteins responsive to different hormones/stresses. *J Proteome Res* 4:1592–1599
- Komatsu S (2005) Rice proteome database: a step toward functional analysis of the rice genome. *Plant Mol Biol* 59:179–190
- Kreps JA, Wu Y, Chang HS, Zhu T, Wang X, Harper JF (2002) Transcriptome changes for *Arabidopsis* in response to salt and cold stress. *Plant Physiol* 130:2129–2141
- Kumar G, Purty RS, Sharma MP, Singla-Pareek SL, Pareek A (2009) Physiological response among *Brassica* species under salinity stress show strong correlation with transcript abundance for SOS pathway related genes. *J Plant Physiol* 166:507–520
- Kumari S, Punjabi VS, Kushwaha H, Sopory SK, Pareek SL, Pareek A (2009) Transcriptome map for seedling stage specific salinity stress response indicates a specific set of genes as candidate for saline tolerance in *Oryza sativa* L. *Funct Integr Genomics* 9:109–123

- Kwon SJ, Choi EY, Seo JB, Park OK (2007) Isolation of *Arabidopsis* phosphoproteome using a biotin-tagging approach. *Mol Cell* 24:268–275
- Lee S, Cohen J, Zhou G, Wang SM (2001) Generation of high-quantity and quality tag/ditag cDNAs for SAGE analysis. *Biotechniques* 31:348–354
- Li S, Armstrong CM, Bertin N, Ge H, Milstein S, Boxem M, Vidalain PQ, Han JD, Chesneau A, Hao T, Goldberg DS, Li N, Martinez M, Rual JF, Lamesch P, Xu L, Tewari M, Wong SL, Zhang LV, Berriz GF, Jacotot L, Vaglio P, Reboul J, Hirozane-Kishikawa T, Li Q, Gabel HW, Elewa A, Baumgartner B, Rose DJ, Yu H, Bosak S, Sequerra R, Fraser A, Mango SE, Saxton WM, Strome S, Van Den Heuvel S, Piano F, Vandenhaute J, Sardet C, Gerstein M, Doucette-Stamm L, Gunsalus KC, Harper JW, Cusick ME, Roth FP, Hill DE, Vidal M (2004) A map of the interactome network of the metazoan *C. elegans*. *Science* 303:540–543
- Lin HX, Zhu MZ, Yano M, Gao JP, Liang ZW, Su WA, Hu XH, Ren ZH, Chao DY (2004) QTLs for Na<sup>+</sup> and K<sup>+</sup> uptake of the shoots and roots controlling rice salt tolerance. *Theor Appl Genet* 108:253–260
- Liu X, Baird WV (2003) Differential expression of genes regulated in response to drought or salinity stress in sunflower. *Crop Sci* 43:678–687
- Ma S, Bohnert HJ (2008) Gene networks for the integration and understanding of gene expression characteristics. *Weed Sci* 56:314–321
- Magdalena S (2005) Network biology: a protein network of one's own protein. *Nat Rev Genet* 6:800
- Malakshah SN, Rezaei MH, Heidari M, Salekdeh GH (2007) Proteomics reveals new salt responsive proteins associated with rice plasma membrane. *Biosci Biotechnol Biochem* 71:2144–2154
- Miller JP, Lo RS, Ben-Haur A, Desmarais C, Stagljar I, Noble WS, Fields S (2005) Large scale identification of yeast integral membrane protein interactions. *Proc Natl Acad Sci USA* 102:12123–12128
- Miyama M, Hanagata N (2007) Microarray analysis of 7029 gene expression patterns in burma mangrove under high salinity stress. *Plant Sci* 172:948–957
- Nita-Lazar A, Saito-Benz H, White FM (2008) Quantitative phosphoproteomics by mass spectrometry: past, present and future. *Proteomics* 8:4433–4443
- Oliver MJ, Velten J, Wood AJ (2000) Bryophytes as experimental models for the study of environmental stress tolerance: *Tortula ruralis* and desiccation-tolerance in mosses. *Plant Ecol* 151:73–84
- O'Toole JC, Baldia EP (1982) Water deficits and mineral uptake in rice. *Crop Sci* 22:1144–1150
- Ouyang B, Yang T, Li H, Zhang L, Zhang Y, Zhang J, Fei Z, Ye Z (2007) Identification of early salt stress response genes in tomato root by suppression subtractive hybridization and microarray analysis. *J Exp Bot* 58:507–520
- Ozturk ZN, Talamé V, Deyholos M, Michalowski CB, Galbraith DW, Gozukirmizi N, Tuberosa R, Bohnert HJ (2002) Monitoring large-scale changes in transcript abundance in drought- and salt-stressed barley. *Plant Mol Biol* 48:551–573
- Pandey A, Chakraborty S, Datta A, Chakraborty N (2007) Proteomics approach to identify dehydration responsive nuclear proteins from chickpea (*Cicer arietinum* L.). *Mol Cell Proteomic* 7:88–107
- Pareek A, Singh A, Kumar M, Kushwaha H, Singla-Pareek S (2006) Whole genome analysis of *Oryza sativa* reveals similar architecture of two-component signaling machinery with *Arabidopsis*. *Plant Physiol* 142:380–397
- Pareek A, Singla-Pareek SL, Sopory SK, Grover A (2007) Analysis of salt stress related transcriptome fingerprints from diverse plant species. In: Varshney RK, Tuberosa R (eds) *Genomics-assisted crop improvement*. Springer Dordrecht, The Netherlands
- Popova OV, Yang O, Dietz KJ, Golldeck D (2008) Differential transcript regulation in *Arabidopsis thaliana* and the halo-tolerant *Lobularia maritime* indicates genes with potential function in plant salt adaptation. *Gene* 423:142–148
- Posas F, Wurgler-Murphy SM, Maeda T, Witten EA, Thai TC, Saito H (1996) Yeast HOG1 MAP kinase cascade is regulated by a multistep phosphorelay mechanism in the SLN1–YPD1–SSK1 “two-component” osmosensor. *Cell* 86:865–875
- Rabbani MA, Maruyama K, Abe H, Khan MA, Katsura K, Ito Y, Yoshiwara K, Seki M, Shinozaki K, Yamaguchi-Shinozaki K (2003) Monitoring expression profiles of rice genes under cold, drought, and high-salinity stresses and abscisic acid application using cDNA microarray and RNA gel-blot analyses. *Plant Physiol* 133:1755–1767
- Ren ZH, Gao JP, Li LG, Cai XL, Huang W, Chao DY, Zhu MZ, Wang ZY, Luan S, Lin HX (2005) A rice quantitative trait locus for salt tolerance encodes a sodium transporter. *Nat Genet* 37:1141–1146
- Richmond T, Somerville S (2000) Chasing the dream: plant EST microarrays. *Curr Opin Plant Biol* 3:108–116
- Rubin GM (2001) The draft sequences: comparing species. *Nature* 409:820–821
- Ruepp A, Zolner A, Maier D, Albermann K, Hani J, Mokrejs M, Tetko I, Guldener U, Mannhaupt G, Munsterkötter M, Mewes MW (2004) The FunCat, a functional annotation scheme for systematic classification of proteins from whole genomes. *Nucleic Acid Res* 32:5539–5545
- Sahi C, Agarwal M, Reddy M, Sopory S, Grover A (2003) Isolation and expression analysis of salt stress-associated ESTs from contrasting rice cultivars using a PCR-based subtraction method. *Theor Appl Genet* 106:620–628
- Salvi S, Tuberosa R (2005) QTL cloning in plants: achievements and perspectives. *Trends Plant Sci* 10:297–304
- Schena M, Shalon D, Davis RW, Brown PO (1995) Quantitative monitoring of gene expression patterns with a complementary DNA microarray. *Science* 270:467–470
- Seki M, Kamei A, Shinozaki KY, Shinozaki K (2003) Molecular responses to drought, salinity and frost: com-

- mon and different paths for plant protection. *Curr Opin Biotech* 114:194–199
- Seki M, Narusaka M, Ishida J, Nanjo T, Fujita M, Oono Y, Kamiya A, Nakajima M, Enju A, Sakurai T, Satou M, Akiyama K, Taji T, Yamaguchi-Shinozaki K, Carninci P, Kawai J, Hayashizaki Y, Shinozaki K (2002) Monitoring the expression profiles of 7000 *Arabidopsis* genes under drought, cold and high-salinity stresses using a full-length cDNA microarray. *Plant J* 31:279–292
- Shinozaki K, Yamaguchi-Shinozaki K (1999) Molecular responses to drought stress. In: Shinozaki K, Yamaguchi-Shinozaki K (eds) *Molecular responses to cold, drought, heat and salt stress in higher plants*. RG Landes, Austin, TX, pp 11–28
- Sreenivasulu N, Sopory SK, Kavi-Kishor PB (2007) Deciphering the regulatory mechanisms of abiotic stress tolerance in plants by genomic approaches. *Gene* 388:1–13
- Sun MM, Li LH, Xie H, Ma RC, He YK (2007) Differentially expressed genes under cold acclimation in *Physcomitrella patens*. *J Biochem Mol Biol* 40:986–1001
- Suprunova T, Krugman T, Distelfeld A, Fahima T, Nevo E, Korol A (2007) Identification of a novel gene (Hsd4) involved in water-stress tolerance in wild barley. *Plant Mol Biol* 64:17–34
- Szathmary E, Jordan F, Pal C (2001) Molecular biology and evolution – can genes explain biological complexity? *Science* 292:1315–1316
- Taji T, Seki M, Satou M, Sakurai T, Kobayashi M, Ishiyama K, Narusaka Y, Narusaka M, Zhu JK, Shinozaki K (2004) Comparative genomics in salt tolerance between *Arabidopsis* and *Arabidopsis*-related halophyte salt cress using *Arabidopsis* microarray. *Plant Physiol* 135:1697–1709
- Tardif G, Kane NA, Adam H, Labrie L, Major G, Gulick P, Sarhan F, Laliberté J-F (2007) Interaction network of proteins associated with abiotic stress response and development in wheat. *Plant Mol Biol* 63:703–718
- Till BJ, Cooper J, Tai TH, Colovit P, Greene EA, Henikoff S, Comai L (2007) Discovery of chemically induced mutants in rice by TILLING. *BMC Plant Biol* 9:7
- Uetz P, Giot L, Cagney G, Mansfield TA, Judson RS, Knight JR, Lockshon D, Narayan V, Srinivasan M, Pochart P, Qureshi-Emili A, Li Y, Godwin B, Conover D, Kalbfleisch T, Vijayadamar G, Yang M, Johnston M, Fields S, Rothberg JM (2000) A comprehensive analysis of protein interactions in *Saccharomyces cerevisiae*. *Nature* 403:623–627
- Urao T, Miyata S, Yamaguchi-Shinozaki K, Shinozaki K (2000) Possible His to Asp phosphorelay signaling in an *Arabidopsis* two-component system. *FEBS Lett* 478:227–232
- Van Hal NLW, Vorst O, Van Houvelingen AMML, Kok EJ, Peijnenburg A, Aharoni A, Van Tunen AJ, Keijzer J (2000) The application of DNA microarrays in gene expression analysis. *J Biotech* 78:271–280
- Velculescu VE, Zhang L, Vogelstein B, Kinzler KW (1995) Serial analysis of gene expression. *Science* 270:484–487
- Walhout AJM, Sordella R, Lu X, Hartley JL, Temple GF, Brasch MA, Thierry-Mieg N, Vidal M (2000) Protein interaction mapping in *C. elegans* using proteins involved in vulval development. *Science* 287:116–122
- Walia H, Wilson C, Condamine P, Liu X, Ismail AM, Zeng L, Wanamaker SI, Mandal J, Xu J, Cui X, Close TJ (2005) Close comparative transcriptional profiling of two contrasting rice genotypes under salinity stress during the vegetative growth stage. *Plant Physiol* 139:822–835
- Walia H, Wilson C, Zeng L, Ismail AM, Condamine P, Close TJ (2007) Genome-wide transcriptional analysis of salinity stressed *japonica* and *indica* rice genotypes during panicle initiation stage. *Plant Mol Biol* 63:609–623
- Wang JP, Bughrara SS (2007) Monitoring of gene expression profiles and identification of candidate genes involved in drought responses in *Festuca mairei*. *Mol Genet Genomics* 277:571–587
- Wang W, Vinocur B, Altman A (2003) Plant responses to drought, salinity and extreme temperatures: towards genetic engineering for stress tolerance. *Planta* 218:1–14
- Wong HL, Sakamoto T, Kawasaki T, Umemura K, Shimamoto K (2004) Down-regulation of metallothionein, a reactive oxygen scavenger, by the small GTPase OsRac1 in rice. *Plant Physiol* 135:1447–1456
- Xu K, Xu X, Fukao T, Canlas P, Maghirang-Rodriguez R, Heuer S, Ismail AM, Bailey-Serres J, Ronald PC, Mackill DJ (2006) *Sub1A* is an ethylene-response-factor-like gene that confers submergence tolerance to rice. *Nature* 442:705–708
- Zhang JZ, Creelman RA, Zhu JK (2004) From laboratory to field – using information from *Arabidopsis* to engineer salt, cold and drought tolerance in crops. *Plant Physiol* 135:615–621
- Zheng BS, Yang L, Zhang WP, Mao CZ, Wu YR, Yi KK, Liu FY, Wu P (2003) Mapping QTLs and candidate genes for rice root traits under different water-supply conditions and comparative analysis across three populations. *Theor Appl Genet* 107:1505–1515
- Zheng J, Zhao J, Tao Y et al (2004) Isolation and analysis of water stress induced genes in maize seedlings by subtractive PCR and cDNA macroarray. *Plant Mol Biol* 55:807–823
- Zhou J, Wang X, Jiao Y, Qin Y, Liu X, He K, Chen C, Ma L, Wang J, Xiong L, Zhang Q, Fan L, Deng XW (2007) Global genome expression analysis of rice in response to drought and high-salinity stresses in shoot, flag leaf and panicle. *Plant Mol Biol* 63:591–608
- Zhu JK (2002) Salt and drought stress signal transduction in plants. *Ann Rev Plant Biol* 53:247–273

# Chapter 10

## Promoters and Transcription Factors in Abiotic Stress-Responsive Gene Expression

Kazuo Nakashima and Kazuko Yamaguchi-Shinozaki\*\*  
*Biological Resources Division, Japan International Research Center  
for Agricultural Sciences (JIRCAS), Ibaraki,  
305-8686, Japan*

*+Laboratory of Plant Molecular Physiology, Graduate School of Agricultural  
and Life Sciences, University of Tokyo, Tokyo,  
113-8657, Japan*

Summary .....	199
I Introduction .....	200
II Significant ABA-Independent Gene Expression Under Abiotic Stress.....	201
A DREB1/CBFs: Major Transcription Factors that Regulate Many Cold-Inducible Genes Involved in Stress Tolerance.....	202
B The DREB/DRE Regulons in Plants Other than Arabidopsis .....	203
C <i>Cis</i> -Acting Regulatory Elements and Transcription Factors that Function Upstream of DREB1/CBF.....	204
D DREB2 Proteins Function in Drought, High Salinity and Heat Stress-Responsive Gene Expression ....	204
III Other ABA-Independent Gene Expression Under Abiotic Stress .....	206
IV ABA-Responsive Gene Expression Under Abiotic Stresses .....	206
V Other Types of ABA-Dependent Gene Expression Under Abiotic Stresses .....	209
VI Conclusions and Future Perspectives .....	210
Acknowledgements .....	211
References .....	211

### Summary

Plant growth and productivity are greatly affected by abiotic stresses such as drought, salinity, high temperature, and low temperature. The expression of a variety of genes that are induced by these stresses has been reported in various plant species. Molecular and genomic analyses have shown that there are several different transcriptional regulatory systems, as well as several different sets of *cis*-acting elements and *trans*-acting factors involved in abiotic stress-responsive gene expression. In this chapter,

---

\*Author for correspondence, e-mail: kazukoys@jircas.affrc.go.jp



we highlight transcriptional regulation of gene expression in response to abiotic stresses, with particular emphasis on the role of transcription factors and *cis*-acting elements in stress-inducible promoters.

**Keywords** abiotic stress • abscisic acid • AREB • DREB/CBF • promoters • transcription factors

## I Introduction

Drought, salinity, high temperature, and low temperature are all environmental conditions that have adverse effects on the growth and productivity of crops plants. Plants have adapted themselves to respond to these stresses at the molecular, cellular, biochemical, as well as at the physiological levels, thus enabling them to survive. Expression of a variety of genes is induced by these abiotic stresses in case of various plants (Ingram and Bartels 1996; Thomashow 1999; Shinozaki et al. 2003). The products of these genes play a role not only in stress tolerance, but also in the regulation of gene expression and signal transduction (Xiong et al. 2002; Shinozaki et al. 2003; Bartels and Sunkar 2005).

The expression patterns of genes induced by environmental stresses such as drought, salinity, and cold in *Arabidopsis* and rice have been earlier analyzed by northern blot analyses and recently by microarray and quantitative real-time polymerase chain reaction (PCR) (Fowler and Thomashow 2002; Kreps et al. 2002; Seki et al. 2002; Rabhani et al. 2003; Vogel et al. 2005). Through this work more than 300 genes have been identified as being stress-inducible. Among these genes, more than half of the drought-inducible genes are also induced by high salinity, indicating the existence of significant cross talk between the

drought and high-salinity responses. By contrast, only 10% of the drought-inducible genes were also induced by cold stress (Seki et al. 2002). The molecular mechanisms regulating gene expression in response to abiotic stresses such as dehydration and cold stresses have been studied by analyzing the *cis*- and *trans*-acting elements during the stresses in *Arabidopsis* (Shinozaki et al. 2003; Yamaguchi-Shinozaki and Shinozaki 2005; Nakashima and Yamaguchi-Shinozaki 2006). Figure 1 shows overall regulatory networks of gene expression and their cascades during drought, high salinity, heat and cold stress responses. Abscisic acid (ABA) is produced under water deficit conditions and plays an important role in the tolerance response of plants to drought and high salinity. Exogenous application of ABA also induces a number of genes that respond to dehydration and cold stress (Zhu 2002; Shinozaki et al. 2003). Several reports have described genes that are induced by dehydration and cold stresses but do not respond to exogenous ABA treatment (Zhu 2002; Shinozaki et al. 2003; Yamaguchi-Shinozaki and Shinozaki 2005). This suggests the existence of ABA-independent, as well as ABA-dependent, signal transduction cascades between the initial stress signal and the expression of specific genes. There are two major *cis*-acting elements – ABRE and DRE/CRT – which function in ABA-dependent and ABA-independent gene expression, respectively, in abiotic stress responses. In addition to these major pathways, many other transcriptional regulatory systems are involved in abiotic stress-responsive gene expression. In this chapter, we focus on transcriptional regulation of gene expression in response to osmotic, heat, and cold stresses, with particular emphasis on the role of transcription factors and *cis*-acting elements in stress-inducible promoters. The signal transduction pathways controlling abiotic stress responses are very complex, and many excellent review articles in this area have recently been published (Chinnusamy et al. 2004; Bartels

---

*Abbreviations:* ABA – abscisic acid; ABF – ABRE-binding factor; ABRE – ABA-responsive element; ANAC *Arabidopsis* NAC; AREB – ABRE-binding protein; bZIP – basic leucine zipper; CBF – C-repeat binding factor; DRE – dehydration responsive element; DREB – DRE-binding protein; ERD – early responsive to dehydration; GFP – green fluorescence protein; HS – heat shock; LEA – late embryogenesis abundant; PCR – polymerase chain reaction; RD – responsive to dehydration; SnRK – sucrose non-fermenting-1-related protein kinase; SUMO – small ubiquitin-related modifier; SNAC – stress-responsive NAC; ZFHD – zinc finger homeo-domain

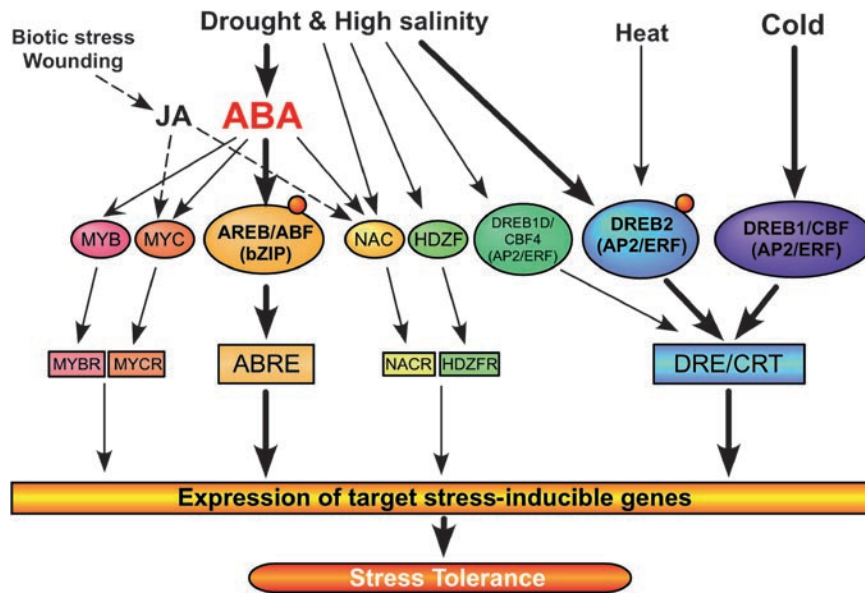

Fig. 1. Transcriptional regulatory networks of *cis*-acting elements and transcription factors involved in abiotic-stress-responsive gene expression in *Arabidopsis*. Transcription factors controlling stress-inducible gene expression are shown in ellipses. *cis*-acting elements involved in stress-responsive transcription are shown in boxes. Small filled circles reveal modification of transcription factors in response to stress signals for their activation, such as phosphorylation [See Color Plate 4, Fig. 8].

and Sunkar 2005; Boudsocq and Lauriere 2005; Sunkar et al. 2007; Tran et al. 2007b; Zhu et al. 2007).

## II Significant ABA-Independent Gene Expression Under Abiotic Stress

The *Arabidopsis RD29A/COR78/LTI78* gene is induced by drought, high salinity, cold and ABA. However, this gene is induced in *aba* or *abi* mutants by both drought and cold stresses, which indicates that it is governed by both ABA-dependent and ABA-independent regulation under drought and cold conditions (Yamaguchi-Shinozaki and Shinozaki 1992). Analyses of this promoter have shown that a 9 bp conserved sequence, TACCGACAT, constitutes a drought response element, termed DRE, which is an essential *cis*-element for regulating *RD29A* induction in the ABA-independent response to dehydration and cold (Yamaguchi-Shinozaki and Shinozaki 1994). DREs are found in the promoter regions of many drought- and cold-inducible genes (Thomashow 1999; Shinozaki and Yamaguchi-Shinozaki 2000). Similar *cis*-acting elements, named C-repeat (CRT) and

low-temperature-responsive element (LTRE), both containing an A/GCCGAC motif that forms the core of the DRE sequence, regulate cold-inducible promoters (Baker et al. 1994; Jiang et al. 1996; Stockinger et al. 1997; Thomashow 1999). The cDNAs encoding DRE/CRT-binding proteins, DREB1/CBF (DRE binding protein 1/C-repeat binding Factor), and DREB2, were isolated using yeast one-hybrid screening (Stockinger et al. 1997; Liu et al. 1998). These proteins contained the conserved DNA-binding domain found in the AP2 and ERF (ethylene-responsive element-binding factor) proteins. These proteins specifically bind to the DRE/CRT sequence and activate the transcription of genes driven by the DRE/CRT sequence (Fig. 2).

In *Arabidopsis*, three genes encoding DREB1/CBF proteins lie in tandem on chromosome 4 in the following order: *DREB1B/CBF1*, *DREB1A/CBF3*, and *DREB1C/CBF2* (Fig. 2; Liu et al. 1998; Shinwari et al. 1998). Expression of the *DREB1/CBF* genes is induced by cold, but not by dehydration and high-salinity stresses. In contrast, expression of the *DREB2* genes, *DREB2A* and *DREB2B*, is induced by dehydration and high-salinity stresses but not by cold stress (Liu et al.

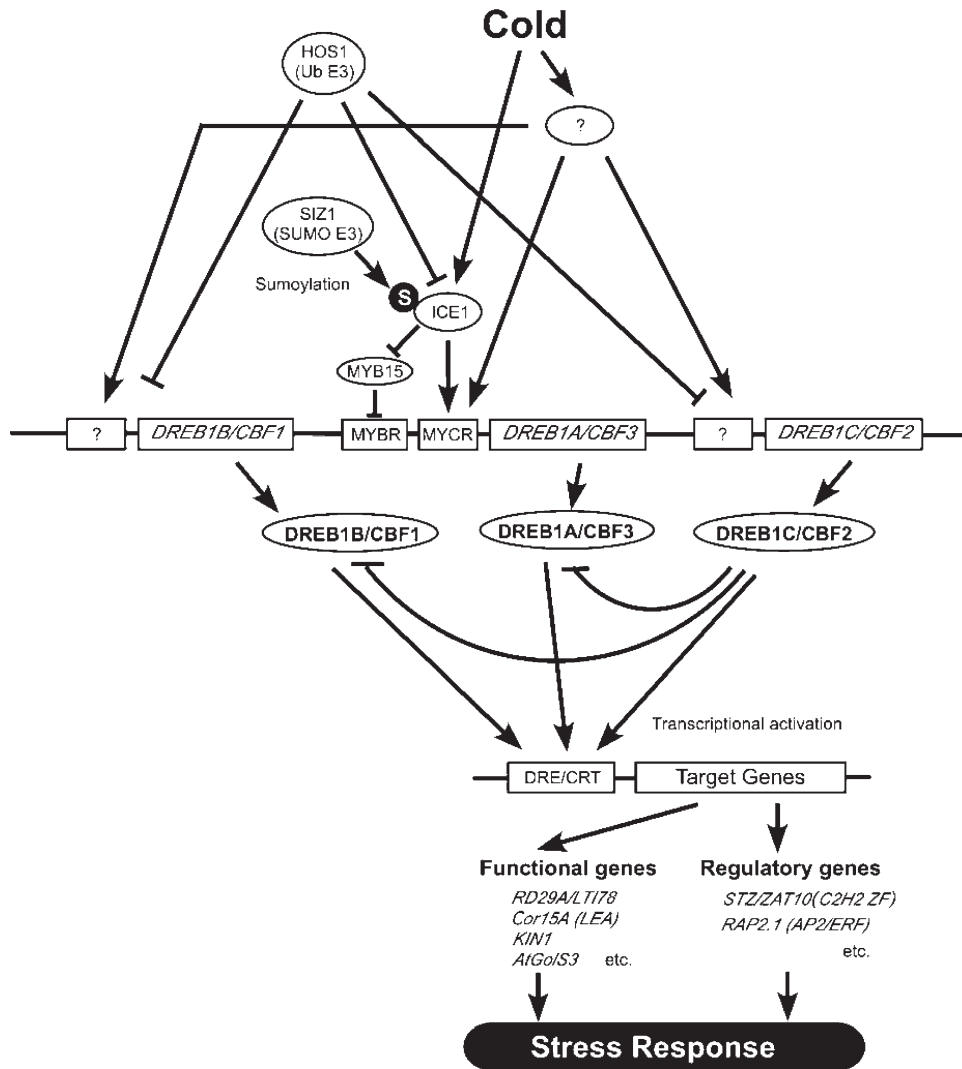

Fig. 2. Transcriptional regulatory networks of DRE/CRT *cis*-acting elements and DREB1/CBF transcription factors involved in cold-stress-responsive gene expression in *Arabidopsis*.

1998; Nakashima et al. 2000). Later, Sakuma et al. (2002) reported three novel DREB1/CBF-related genes and six novel DREB2-related genes that were not expressed at high levels under various stress conditions. The three DREB1 proteins are probably major transcription factors involved in cold-induced gene expression and the DREB2A and DREB2B proteins are involved in high-salinity- and drought-induced gene expression. However, the expression of one of the CBF/DREB1 genes, *CBF4/DREB1D*, is induced by osmotic stress (Haake et al. 2002) and the other two CBF/DREB1 genes, *DDF1/DREB1F* and *DDF2/DREB1E*, are induced by high-salinity

stress (Magome et al., 2004), suggesting the existence of cross-talk between the CBF/DREB1 and the DREB2 pathways.

#### A DREB1/CBFs: Major Transcription Factors that Regulate Many Cold-Inducible Genes Involved in Stress Tolerance

Transgenic *Arabidopsis* plants over-expressing *CBF1/DREB1B* under control of the cauliflower mosaic virus (CaMV) 35S promoter showed a high tolerance to freezing stress (Jaglo-Ottosen et al. 1998). Over-expression of the *DREB1A/CBF3* under the control of the CaMV 35S promoter

also increased the tolerance to drought, high-salinity and freezing stresses (Liu et al. 1998; Kasuga et al. 1999; Gilmour et al. 2000). These transgenic plants also caused growth retardation under normal growth conditions. Use of the stress-inducible *RD29A* promoter instead of the constitutive CaMV 35S promoter for the over-expression of *DREB1A/CBF3* minimizes the negative effects on plant growth (Kasuga et al. 1999).

More than 40 genes downstream of DREB1/CBF have been identified through the use of both cDNA and Gene Chip microarrays (Seki et al. 2001; Fowler and Thomashow 2002; Maruyama et al. 2004; Vogel et al. 2005). Many of their protein products, such as late embryogenesis abundant (LEA) proteins, KIN (cold-inducible) proteins, and osmo-protectant biosynthesis protein, function against stresses and are probably responsible for the stress tolerance of the transgenic plants (Fig. 2). The downstream genes also included genes for transcription factors such as C2H2 zinc-finger-type and AP2/ERF-type transcription factors, suggesting the existence of further regulation of gene expression downstream of the DRE/DREB regulon (Maruyama et al. 2004; Sakamoto et al. 2004). The product of one such downstream gene, STZ, functions as a C2H2 zinc-finger-type transcriptional repressor, and its over-expression retards growth and induces tolerance to drought stress (Sakamoto et al. 2004). The down-regulated target genes of STZ might promote plant tolerance and inhibit plant growth under stress conditions. Conserved sequences in the promoter regions of the genes directly downstream of DREB1A were analyzed and A/GCCGACNT was found in their promoter regions between -51 and -450 as a consensus DRE/CRT (Maruyama et al. 2004). The recombinant DREB1A/CBF3 protein bound to A/GCCGACNT more efficiently than to A/GCCGACNA/G/C. Thus, analysis of promoter regions of direct target genes of a transcription factor allows the accurate elucidation of a *cis*-acting element that functions in plants.

### B The DREB/DRE Regulons in Plants Other than *Arabidopsis*

DRE/CRT functions in gene expression in response to stress in tobacco plants, which suggests the existence of similar regulatory systems in tobacco and most likely also in other crop plants (Yamaguchi-Shinozaki and Shinozaki 1994). The DRE/CRT-related motifs have been reported in

the promoter region of cold-inducible *Brassica napus* and wheat genes (Jiang et al. 1996; Ouellet et al. 1998). However, the orthologous genes of *DREB1/CBF* have been isolated in many plant species such as wheat, *Brassica napus*, rice, barley, maize and cherry (Jaglo et al. 2001; Choi et al. 2002; Gao et al. 2002; Dubouzet et al. 2003; Shen et al. 2003a, b; Vagujfalvi et al., 2003; Xue 2003; Kitashiba et al. 2004; Qin et al. 2004). Over-expression of the *Arabidopsis* *DREB1/CBF* genes in transgenic *B. napus* or tobacco plants induced expression of orthologs of *Arabidopsis* *DREB1/CBF*-targeted genes and increased the freezing and drought tolerance of transgenic plants (Jaglo et al. 2001; Kasuga et al. 2004). Constitutive over-expression of *DREB1B/CBF1* in transgenic tomato increased drought, chilling and oxidative stress tolerance (Hsieh et al. 2002a, b; Zhang et al. 2004).

In rice, four DREB1/CBF homologous genes and one DREB2 homologous gene, *OsDREB1A*, *OsDREB1B*, *OsDREB1C* and *OsDREB1D*, and *OsDREB2A*, respectively, have been isolated (Dubouzet et al. 2003). Over-expression of *OsDREB1A* in transgenic *Arabidopsis* resulted in improved high-salinity and freezing stress tolerance. A DREB1/CBF-type transcription factor, ZmDREB1A, was also identified in maize (Qin et al. 2004). The ZmDREB1A protein was shown to be involved in cold-responsive gene expression, and the over-expression of this gene in *Arabidopsis* resulted in improved stress tolerance to drought and freezing. These transgenic plants also showed growth retardation. These results indicate that similar regulatory systems are conserved in monocots as well as in dicot plants. Pellegrineschi et al. (2004) showed that over-expression of *DREB1A/CBF3* driven by the stress-inducible *RD29A* promoter in transgenic wheat improved drought stress tolerance. Oh et al. (2005) reported that constitutive over-expression of *DREB1A* using the 35S promoter in transgenic rice resulted in increased stress tolerance to drought and high salinity. Ito et al. (2006) generated transgenic rice plants over-expressing the *OsDREB1* or *DREB1* genes. These transgenic rice plants showed not only growth retardation under normal growth conditions but also improved tolerance to drought, high-salt and low-temperature stresses like the transgenic *Arabidopsis* plants over-expressing *OsDREB1* or *DREB1*. They also detected elevated contents of osmo-protectants such as free proline



and various soluble sugars in the transgenic rice as in the transgenic *Arabidopsis* plants. They identified target stress-inducible genes of *OsDREB1A* in the transgenic rice using microarray and RNA gel blot analyses. These genes encode proteins that are thought to function in stress tolerance in the plants. These observations suggest that the DRE/DREB regulon can be used to improve the tolerance of various kinds of agriculturally important crop plants to drought, high-salinity, and freezing stresses by gene transfer.

### C *Cis-Acting Regulatory Elements and Transcription Factors that Function Upstream of DREB1/CBF*

HOS1, ICE1, and MYB15 are direct regulators of *DREB1/CBF* expression (Fig. 2; Agarwal et al. 2006; Chinnusamy et al. 2006; Dong et al. 2006). The HOS1 is a RING-type ubiquitin E3 ligase that negatively regulates cold-induced *DREB1/CBF* expression (Ishitani et al. 1998). ICE1 is a MYC-like basic helix-loop-helix transcription factor that activates *CBF/DREB1* expression in response to low temperatures (Chinnusamy et al. 2003). ICE1 binds to canonical MYC *cis*-elements (CANNTG) in the *DREB1A/CBF3* promoter to induce expression (Chinnusamy et al. 2003; Lee et al. 2005). HOS1 negatively regulates ICE1 function in low temperature adaptation (Dong et al. 2006). HOS1 migrates to the nucleus in response to cold treatment and mediates the ubiquitination and degradation of ICE1 (Lee et al. 2001; Dong et al. 2006). MYB15 binds to *DREB1/CBF* promoter regions and represses expression of *DREB1/CBF* and negatively regulates freezing tolerance (Agarwal et al. 2006). ICE1 also physically interacts with MYB15 and attenuates MYB15 expression. Together, these results indicate that the ubiquitin E3 ligase HOS1, MYC transcription factor ICE1 and MYB transcription factor MYB15 function in a regulatory cascade to modulate expression of *DREB1A/CBF3*, and perhaps *DREB1B/CBF1* and *DREB1C/CBF2*, to control plant responses to low temperatures (Fig. 2).

SUMO (small ubiquitin-related modifier) conjugation to protein substrates (sumoylation) is a reversible post-translational modification that is regulated by environmental stimuli in animals and yeasts (Johnson 2004). The *Arabidopsis* SUMO

E3 ligase SIZ1 participates in responses to phosphate starvation, salicylic acid-mediated signaling in plant defense, and basal thermo-tolerance (Miura et al. 2005; Yoo et al. 2006; Lee et al. 2007). Furthermore, Miura et al. (2007) reported that SIZ1 is a regulator of cold acclimation by controlling ICE1 activity, *DREB1/CBF* expression, particularly *DREB1A/CBF3*, and target gene function. A K393R mutation blocks sumoylation of ICE1, represses expression of *DREB1A/CBF3* and its target genes, and reduces freezing tolerance. They presented evidence that sumoylation of ICE1 represses poly-ubiquitination of the protein that leads to enhanced stability of ICE1 at low temperatures. Sumoylation of ICE1 also represses expression of the negative regulator MYB15. These results indicate that SIZ1-mediated SUMO conjugation/deconjugation of ICE1 is a key process that initiates many changes in gene expression that are required for low temperature tolerance (Fig. 2). However, ICE1 does not regulate the expression of *DREB1B/CBF1* and *DREB1C/CBF2*. Thus, the transcription factors that bind to these *cis*-acting elements remain to be identified.

Novillo et al. (2004) reported that the *cbf2* mutant, in which the *DREB1C/CBF2* gene has been disrupted, has higher capacity to tolerate freezing, dehydration and salt stresses. They found that *DREB1/CBF*-regulated genes showed stronger and more sustained expression in the *cbf2* plants, which results from increased expression of *DREB1A/CBF3* and *DREB1B/CBF1* in the mutant. Thus, *DREB1C/CBF2* functions as a negative regulator of *DREB1A/CBF3* and *DREB1B/CBF1* expression in *Arabidopsis*, indicating complex regulation of *DREB1/CBF* gene expression.

### D *DREB2 Proteins Function in Drought, High Salinity and Heat Stress-Responsive Gene Expression*

The DREB2A protein has a conserved AP2/ERF DNA-binding domain and recognizes the DRE/CRT sequence like DREB1/CBFs (Liu et al. 1998). Among the eight *Arabidopsis* DREB2-type proteins, DREB2A and DREB2B are major transcription factors that function under dehydration and high-salinity stress conditions (Nakashima et al. 2000; Sakuma et al. 2002). However, overexpression of DREB2A in transgenic plants neither

caused growth retardation nor improved stress tolerance, suggesting that the DREB2A protein requires post-translational modification such as phosphorylation for its activation (Liu et al. 1998). Nevertheless, the activation mechanism of the DREB2A protein has not yet been elucidated. Domain analysis of DREB2A using *Arabidopsis* protoplasts revealed that a negative regulatory domain exists in the central region of DREB2A and deletion of this region transforms DREB2A to a constitutive active form. Over-expression of the constitutive active form of DREB2A (DREB2A CA) resulted in growth retardation in transgenic *Arabidopsis* plants (Sakuma et al. 2006a). These transgenic plants revealed significant tolerance to drought stress but only slight tolerance to freezing. Microarray analyses of the transgenic plants revealed that DREB2A regulates expression of many dehydration-inducible genes. However, some genes downstream of DREB2A are not downstream of DREB1A, which also recognizes DRE/CRT but functions in cold-stress-responsive gene expression. The genes downstream of DREB2A play an important role in drought stress tolerance,

but alone are not sufficient to withstand freezing stress. Microarray analysis of transgenic *Arabidopsis* over-expressing DREB2A CA revealed that the over-expression of DREB2A CA induces not only drought- and salt-responsive genes but also heat-shock (HS)-related genes (Fig. 3; Sakuma et al. 2006b). Moreover, we found that transient induction of the DREB2A occurs rapidly by HS stress, and that the sGFP-DREB2A protein accumulates in nuclei of HS-stressed cells. DREB2A up-regulated genes were classified into three groups based on their expression patterns: genes induced by HS, genes induced by drought stress, and genes induced by both HS and drought stress. DREB2A up-regulated genes were down-regulated in *DREB2A* knockout mutants under stress conditions. Thermo-tolerance was significantly increased in plants over-expressing *DREB2A CA* and decreased in *DREB2A* knockout plants. Collectively, these results indicate that DREB2A functions in both water and HS-stress responses. New data showed that HS transcription factor HsfA3 regulates expression of many heat-inducible genes in the transcriptional cascade downstream of the

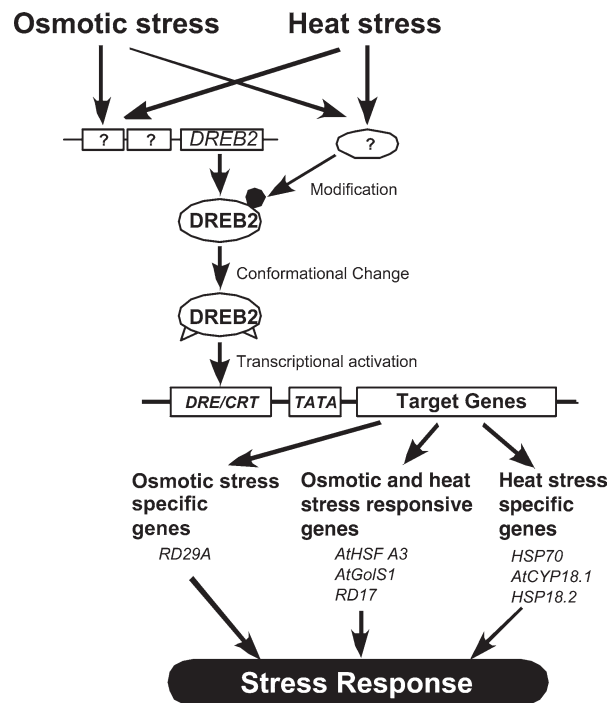

Fig. 3. Transcriptional regulatory networks of DRE/CRT *cis*-acting elements and DREB2 transcription factors involved in drought-, high salinity-, and heat-stress-responsive gene expression in *Arabidopsis*.

DREB2A stress-regulatory system and functions in acquisition of thermo-tolerance under the control of the DREB2A cascade (Schramm et al. 2008; Yoshida et al. 2008). Recently, Qin et al. (2008) isolated *Arabidopsis* DREB2A-INTERACTING PROTEIN1 (DRIP1) and DRIP2, C3HC4 RING domain-containing proteins that interact with the DREB2A protein in the nucleus. They found that DRIP1 and DRIP2 function negatively in the response of plants to drought stress. Moreover, over-expression of full-length DREB2A protein was more stable in *drip1* than in the wild-type background. The results suggest that DRIP1 and DRIP2 act as novel negative regulators in drought-responsive gene expression by targeting DREB2A to 26S proteome proteolysis.

On the other hand, Qin et al. (2007) cloned a DREB2 homolog from maize, ZmDREB2A, whose transcripts were accumulated by cold, dehydration, salt and heat stresses in maize seedlings. Unlike *Arabidopsis* DREB2A, ZmDREB2A produced two forms of transcripts, and quantitative real-time PCR analyses demonstrated that only the functional transcription form of ZmDREB2A was significantly induced by stresses. Moreover, the ZmDREB2A protein exhibited considerably high trans-activation activity compared with DREB2A in *Arabidopsis* protoplasts, suggesting that protein modification is not necessary for ZmDREB2A to be active. Constitutive or stress-inducible expression of ZmDREB2A resulted in an improved drought stress tolerance in *Arabidopsis* plants. Microarray analyses of transgenic *Arabidopsis* plants over-expressing ZmDREB2A revealed that in addition to genes encoding LEA proteins, some genes related to heat shock and detoxification were also upregulated. Furthermore, over-expression of ZmDREB2A also enhanced thermo-tolerance in transgenic plants, implying that ZmDREB2A may play a dual functional role in mediating the expression of genes responsive to both water stress and heat stress.

### III Other ABA-Independent Gene Expression Under Abiotic Stress

There are other ABA-independent pathways in the dehydration stress response. *Early response to dehydration 1* (*ERD1*) encodes a Clp protease regulatory subunit, ClpD (Nakashima

et al. 1997). *ERD1* is not only induced by dehydration, but also upregulated during natural senescence and dark-induced senescence. Promoter analysis of *ERD1* in transgenic plants indicates that the *cis*-acting elements responsible for gene expression during dehydration and etiolation are separately located in two discrete portions of the *ERD1* promoter. Moreover, two different novel *cis*-acting elements, a MYC-like sequence (CATGTG) and a 14 bp rps1 site 1-like sequence, are involved in induction by dehydration stress (Simpson et al. 2003). Three cDNAs encoding NAC-like sequence-binding proteins – ANAC019, ANAC055, and ANAC072 – were isolated by the yeast one-hybrid screening method (Tran et al. 2004). Microarray analysis of transgenic plants over-expressing ANAC019, ANAC055 or ANAC072 revealed that several stress-inducible genes were upregulated in the transgenic plants, and the plants showed significantly increased drought tolerance. However, *ERD1* was not upregulated in the transgenic plants. cDNAs for the transcription factor that binds to the 14 bp rps1 site 1-like sequence was isolated by using one-hybrid screening. These cDNAs encoded zinc-finger homeo-domain (ZFHD) proteins and one of these genes, ZFHD1, was shown to function as a transcriptional activator in response to dehydration stress (Tran et al. 2007a). Overproduction of both the NAC and ZFHD proteins increased expression of *ERD1*, indicating that both *cis*-acting elements are necessary for expression of *ERD1*. The NAC proteins function as transcription activators in cooperation with the ZFHD proteins or alone.

### IV ABA-Responsive Gene Expression Under Abiotic Stresses

Many ABA-inducible genes contain a conserved, ABA-responsive, *cis*-acting element named ABRE (ABA-responsive element; PyACGTGGC) in their promoter regions. The ABRE functions as a *cis*-acting DNA element involved in ABA-regulated gene expression. ABRE is a major *cis*-acting element in ABA-responsive gene expression. For ABA-responsive transcription, a single copy of ABRE is not sufficient. ABRE and coupling elements such as coupling element 1 (CE1) and coupling element three (CE3) constitute

an ABA-responsive complex in the regulation of wheat *HVA1* and *HVA22* genes (Shen and Ho, 1995; Shen et al., 1996). Two ABRE sequences are necessary for the expression of *Arabidopsis RD29B* in seeds and for the ABA-responsive expression of *RD29B* in vegetative tissue (Uno et al. 2000; Nakashima et al. 2006). One of these ABRE sequences might function as a coupling element. Most of the known coupling elements have similarity with ABREs and contain an A/GCGT motif (Hobo et al. 1999b). Many abiotic stress-inducible genes contain DRE/CRT, as well as ABRE in their promoter regions (Yamaguchi-Shinozaki and Shinozaki 1994, 2005). The expression of the promoter region of the *Arabidopsis RD29A* gene is induced by dehydration, high-salinity, low-temperature and ABA treatments and its promoter region contains DRE/CRT sequences and one ABRE sequence. Deletion and base substitution analyses of this region showed that the DRE/CRT sequence can be a coupling element of ABRE. DRE/CRT and ABRE were found to be interdependent in the ABA-responsive expression of the *RD29A* gene in response to ABA in *Arabidopsis* (Narusaka et al. 2003; Nakashima et al. 2006). Either additional copies of the ABRE or coupling elements are necessary for ABA-responsive gene expression.

*Arabidopsis* cDNAs encoding the bZIP transcription factors referred to as ABRE-binding (AREB) proteins or ABRE-binding factors (ABFs) were isolated using the yeast one-hybrid screening method (Choi et al. 2000; Uno et al. 2000). Uno et al. (2000) reported that expression of *AREB1/ABF2*, *AREB2/ABF4*, and *AREB3* was up-regulated by ABA, dehydration and high-salinity stresses. They function as *trans*-acting activators through transient expression studies in protoplasts. Their activities were reduced in the ABA-deficient *aba2* mutant and in the ABA-insensitive *abi1* mutant, but were enhanced in the ABA-hypersensitive *era1* mutant (Koornneef et al. 1984, 1992; Uno et al. 2000). In the *Arabidopsis* genome, 75 distinct bZIP transcription factors exist and 13 members are classified as a homologous sub-family of AREB/ABFs that contain three N-terminal (C1, C2, C3) and one C-terminal (C4) conserved domains (Bensmihen et al. 2002; Jakoby et al. 2002). Most of the AREB/ABF sub-family proteins are involved in ABA-responsive signal transduction pathways

in vegetative tissues or seeds (Choi et al. 2000; Finkelstein and Lynch 2000; Lopez-Molina and Chua 2000; Uno et al. 2000). *Arabidopsis AREB1/ABF2*, *AREB2/ABF4*, and *ABF3* were mainly expressed in vegetative tissues but not in seeds (Choi et al. 2000; Uno et al. 2000; Fujita et al. 2005; Nakashima et al. 2006), whereas *Arabidopsis ABI5* and *EEL* were expressed during seed maturation and/or germination (Finkelstein and Lynch 2000; Lopez-Molina and Chua 2000; Bensmihen et al. 2002; Nakashima et al. 2006). Rice homolog TRAB1 and barley homolog HvABI5 also activate ABA-responsive gene expression in seeds (Hobo et al. 1999a; Casaretto and Ho 2003). It is possible that redundancy and tissue-specific expression of these genes may be important for their function.

Kang et al. (2002) reported that over-expression of *ABF3* and *ABF4/AREB2* resulted in ABA-hypersensitive phenotypes in germination and seedling growth stages in *Arabidopsis*. These transgenic plants also showed improvement of drought stress tolerance and the expression of some ABA-responsive genes, such as LEA class genes (*RD29B*, *RAB18*), cell cycle regulator genes (*ICK1*) and protein phosphatase 2C genes (*ABI1* and *ABI2*), suggesting that AREB/ABF proteins are involved in ABA response and stress tolerance in plants. Moreover, *AREB1/ABF2* was shown to be an essential component of glucose signaling, and its over-expression also improved stress tolerance to drought (Kim et al. 2004). Fujita et al. (2005) reported that over-expression of *AREB1/ABF2* in transgenic plants is not sufficient to activate its downstream genes such as *RD29B*. Domain analysis of *AREB1* using *Arabidopsis* protoplasts revealed that an activation domain exists in the N-terminal region of *AREB1*. To overcome the masked transactivation activity of *AREB1*, a constitutive active form of *AREB1* was created using the N-terminal activation and bZIP DNA-binding domains. Transgenic *Arabidopsis* plants over-expressing the active form of *AREB1* showed ABA hypersensitivity and enhanced drought tolerance, and eight genes in two groups were upregulated: LEA-class genes and ABA- and dehydration-stress-inducible regulatory genes such as linker histone H1 and AAA ATPase. In the promoter region of each gene, two or more ABRE motifs were found. By contrast, an *areb1* null mutant and a dominant loss-of-function



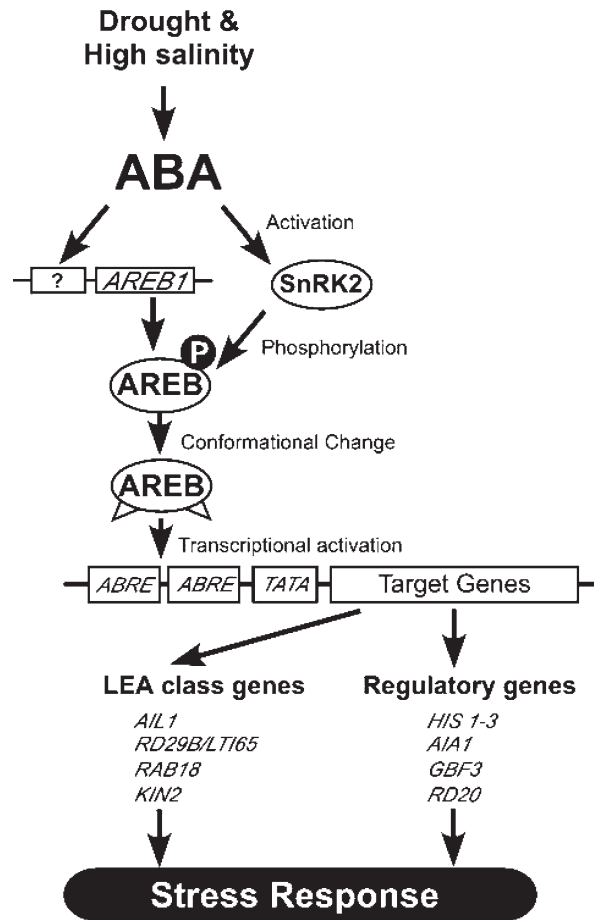

Fig. 4. Transcriptional regulatory networks of ABRE *cis*-acting elements and AREB transcription factors involved in drought- and high salinity-stress-responsive gene expression in *Arabidopsis*.

mutant of AREB1 with a repression domain exhibited ABA insensitivity and some of the upregulated genes were downregulated (Fig. 4; Fujita et al. 2005). Thus, AREBs/ABFs regulate ABA-mediated ABRE-dependent gene expression that enhances drought tolerance in vegetative tissues, and phosphorylation/dephosphorylation plays an important role in the activation of the AREB/ABF proteins.

However, AREB1/ABF2 and AREB2/ABF4 require ABA for their maximum activation, as shown by their low transactivation abilities in protoplasts prepared from the ABA-deficient *aba2* mutant (Uno et al. 2000). ABA-responsive 42 kDa kinase activities phosphorylate conserved regions of AREB/ABFs, which suggests that ABA-dependent phosphorylation may be involved in

activation of the AREB subfamily proteins (Uno et al. 2000). Because AREB1 over-expression could not induce downstream gene expression, activation of AREB1 requires ABA-dependent post-transcriptional modification. ABA activated 42 kDa kinase activity, which, in turn, phosphorylated Ser/Thr residues of R-X-X-S/T sites in the conserved regions of AREB1 (Furihata et al. 2006). Amino acid substitutions of R-X-X-S/T sites to Ala suppressed transactivation activity, and multiple substitution of these sites resulted in almost complete suppression of transactivation activity in transient assays. In contrast, substitution of the Ser/Thr residues to Asp resulted in high transactivation activity without exogenous ABA application. A phosphorylated, transcriptionally active form was achieved by substitution

of Ser/Thr in all conserved R-X-X-S/T sites to Asp. Transgenic plants over-expressing the phosphorylated active form of AREB1 expressed many ABA-inducible genes, such as *RD29B*, without ABA treatment. These results indicate that the ABA-dependent multisite phosphorylation of AREB1 regulates its own activation in plants. Phosphorylation- and dephosphorylation-regulated events play important roles in ABA signaling. Several type-2 SNF1-related protein kinases (SnRK2-type) such as AAPK (ABA activated protein kinase) in *Vicia faba* (Li et al. 2000) and OST1/SRK2E in *Arabidopsis* (Mustilli et al. 2002; Yoshida et al. 2002) were reported as ABA-activated protein kinases, and were shown to mediate the regulation of stomatal aperture and function upstream of ABA-responsive expression. In *Arabidopsis*, nine of ten SnRK2 are activated by hyper-osmolarity and five of the ten SnRK2 are activated by ABA (Boudsocq et al. 2004). Recently, Fujii et al. (2007) showed that two protein kinases, SnRK2.2/SRK2D and SnRK2.3/SRK2I, control responses to ABA in seed germination, dormancy, and seedling growth in *Arabidopsis thaliana*. A *snrk2.2 snrk2.3* double mutant, but not *snrk2.2* or *snrk2.3* single mutants, showed strong ABA-insensitive phenotypes in seed germination and root growth inhibition. Changes in seed dormancy and ABA-induced Pro accumulation consistent with ABA insensitivity were also observed. The *snrk2.2 snrk2.3* double mutant had a greatly reduced level of a 42 kDa kinase activity capable of phosphorylating peptides from AREB/ABF. ABA-induced expression of several genes whose promoters contain an ABRE was reduced in *snrk2.2 snrk2.3*, suggesting that the mechanism of SnRK2.2 and SnRK2.3 action in ABA signaling involves the activation of ABRE-driven gene expression through the phosphorylation of AREB/ABFs. Together, these results demonstrate that SnRK2.2 and SnRK2.3 are redundant but key protein kinases that mediate a major part of ABA signaling in *Arabidopsis*.

In rice, ABRE-binding factor TRAB1 was shown to be phosphorylated rapidly in response to ABA (Kagaya et al. 2002). Ten SnRK2 protein kinases were reported. All family members are activated by hyperosmotic stress and three of them are also activated by ABA (Kobayashi et al. 2004). This rice ABA-activated SnRK2 can phosphorylate TRAB1 (Kobayashi et al. 2005). Thus,

the ABA-activated SnRK2 protein kinases were shown to phosphorylate and activate the AREB/ABF-type proteins in *Arabidopsis* and rice.

## V Other Types of ABA-Dependent Gene Expression Under Abiotic Stresses

ABRE-like motifs are not involved in the ABA regulation of some stress-inducible genes such as *RD22*. Induction of the dehydration-inducible *RD22* is mediated by ABA and requires protein biosynthesis for its ABA-dependent expression (Abe et al. 1997). MYC and MYB recognition sites in the *RD22* promoter function as *cis*-acting elements in the dehydration-inducible expression of *RD22* (Abe et al. 2003). A MYC transcription factor, AtMYC2 (rd22BP1) and a MYB transcription factor, AtMYB2, bind these *cis*-elements in the *RD22* promoter and cooperatively activate the expression of *RD22*. These two transcription factors are synthesized after the accumulation of endogenous ABA, indicating that they play roles in a late stage of the plant's response to different stresses. Transgenic plants overproducing MYC and MYB had higher sensitivity to ABA and revealed osmotic stress tolerance (Abe et al. 2003). Microarray analysis of the transgenic plants indicated the presence of several target genes such as ABA-inducible genes, including an AtADH gene and jasmonic acid (JA)-inducible genes (Abe et al. 2003). By contrast, an AtMYC2 mutant was less sensitive to ABA and showed significantly decreased ABA-induced gene expression of *RD22* and *AtADH1*. Recently, AtMYC2 was also reported as a transcription factor that functions in JA and JA-ethylene-regulated defense responses in *Arabidopsis* (Anderson et al. 2004; Boter et al. 2004; Lorenzo et al. 2004). Cross talk occurs on AtMYC2 between ABA- and JA-responsive gene expressions at the MYC recognition sites in the promoters. In addition, genetic analysis of AtMYC2 suggests that it acts as a negative regulator of blue-light-mediated photomorphogenic growth (Yadav et al. 2005). AtMYC2 might be a common transcription factor of ABA, JA and light-signaling pathways in *Arabidopsis*.

*Arabidopsis RD26* encodes a NAC protein and is induced not only by dehydration but also by ABA. Transgenic plants over-expressing *RD26* were highly sensitive to ABA, whereas *RD26*-

repressed plants were insensitive (M. Fujita et al. 2004). Microarray analysis showed that ABA- and stress-inducible genes were upregulated in *RD26*-overexpressing plants and repressed in *RD26*-repressed plants, indicating that a *cis*-regulatory factor, the NAC recognition site, may function in ABA-dependent gene expression under stress conditions. The *OsNAC6* gene is a member of the NAC transcription factor gene family in rice (Ohnishi et al. 2005; Nakashima et al. 2007). Expression of *OsNAC6* is induced by abiotic stresses, including cold, drought, salinity and ABA. *OsNAC6* gene expression is also induced by JA, wounding and blast disease. A transactivation assay using a yeast system demonstrated that OsNAC6 functions as a transcriptional activator, and transient localization studies with OsNAC6-sGFP fusion protein revealed its nuclear localization. Transgenic rice plants over-expressing *OsNAC6* constitutively exhibited growth retardation and low reproductive yields. These transgenic rice plants showed an improved tolerance to dehydration and high-salt stresses, and also exhibited increased tolerance to blast disease. By utilizing stress-inducible promoters, such as the *OsNAC6* promoter, it is hoped that stress-inducible over-expression of OsNAC6 in rice can improve stress tolerance by suppressing the negative effects of OsNAC6 on growth under normal growth conditions. The results of microarray analysis revealed that many genes that are inducible by abiotic and biotic stresses were upregulated in rice plants over-expressing *OsNAC6*. A transient transactivation assay showed that OsNAC6 activates the expression of at least two genes, including a gene encoding peroxidase. Collectively, these results indicate that OsNAC6 functions as a transcriptional activator in response to abiotic and biotic stresses in plants. Recently, Hu et al. (2006, 2008) reported that over-expression of stress-responsive gene *SNAC1* (*STRESS-RESPONSIVE NAC1*) and *SNAC2/OsNAC6* enhance drought and salt tolerance in transgenic rice without growth retardation. Completion of the rice genome project revealed that the rice genome contains six homologous genes including *OsNAC6* and *SNAC1* (Ooka et al. 2003). Comparative characterizations of gene expression patterns, functional relatedness to growth and tolerance for abiotic- and biotic-stresses, as well as the target genes of these homologous factors remain to be solved.

## VI Conclusions and Future Perspectives

Many plant genes are regulated in response to abiotic stresses, such as dehydration, high-salinity, heat and cold, and their gene products function in stress response and tolerance. In the signal transduction network from perception of stress signals to stress-responsive gene expression, various transcription factors and *cis*-acting elements in the stress-responsive promoters function not only as molecular switches for gene expression but also as terminal points of stress signals in the signaling processes (Fig. 1). Different *cis*-acting elements and transcription factors are involved in the cross talk between different stress signals that regulate gene expression. DRE/CRT functions in cross talk between dehydration/salinity stress response and cold stress response. DREB1/CBF and DREB2 transcription factors function in cross talk between dehydration/salinity stress response, cold stress response, and heat stress response. Combinations of *cis*-acting elements and transcription factors are important to determine cross talk in stress signaling pathways. Temporal and special control of stress-responsive gene expression is regulated by a combination of transcription factors and *cis*-acting elements in stress-inducible promoters. DRE/CRT and ABRE are major *cis*-acting elements in abiotic stress-inducible gene expression. DRE/CRT functions in the early process of stress-responsive gene expression, whereas ABRE functions after the accumulation of ABA during dehydration and high-salinity stress response. There are many ABA-inducible transcription factors that function downstream of ABA responses and stress responses. These transcription factors are involved mainly in late and adaptive processes during stress responses. Negative regulation as well as positive regulation is important for gene expression. The degradation of transcription factor proteins plays an important role in the negative regulation of gene expression. Complex regulation of gene expression may cause complex and flexible responses of plants to abiotic stresses.

Although many kinds of transcriptional factors have been reported to improve stress tolerance (Jaglo-Ottosen et al. 1998; Liu et al. 1998; Kang et al. 2002; Fujita et al. 2005; Furihata et al. 2006; Ito et al. 2006; Sakuma et al. 2006a, b; Nakashima et al. 2007) growth retardation has been commonly

observed in the transgenic plants over-expressing the stress-related transcription factors (Zhang et al. 2004; Nakashima and Yamaguchi-Shinozaki 2005). For example, the DREB1/CBF genes of *Arabidopsis* have been shown to improve abiotic stress tolerance in a number of different species, however, their constitutive over-expression in transgenic plants showed an undesirable dwarf phenotype (Liu et al. 1998; Gilmour et al. 2000). A combination of the *Arabidopsis* DREB1A/CBF3 gene and the stress-inducible RD29A promoter improved environmental stress tolerance in *Arabidopsis* and tobacco by gene transfer (Kasuga et al. 1999, 2004). The *OsNAC6*-over-expressing plants showed growth retardation and lower productivity in rice, although they showed improved stress tolerance (Nakashima et al. 2007). We also showed that stress-inducible promoters, including the LIP9 promoter and especially the *OsNAC6* promoter, effectively over-expressed *OsNAC6* in rice and simultaneously improved stress tolerance without growth retardation effects. Thus, we conclude that both of these stress-inducible promoters can be effectively used in rice to over-express stress-tolerant genes, including *OsNAC6*, as a means to improve stress tolerance by suppressing the negative effects of *OsNAC6* on plant growth. This substantial increased resistance to water stress indicates that a combination of the stress-inducible promoter such as RD29A promoter of *Arabidopsis* and *OsNAC6* promoter of rice and the transcription factors such as DREB1A/CBF3 and AREB1 is useful for improvement of various kinds of transgenic plants that are tolerant to environmental stress. We are currently collaborating with many research groups and we have the common goal to improve stress tolerant crop plants utilizing regulon biotechnology (Nakashima and Yamaguchi-Shinozaki 2005). It is hoped in the future that the collective efforts and results of these collaborative studies will positively contribute to sustainable food production in developing countries and will help to prevent global-scale environmental damage that is resultant from abiotic stress.

## Acknowledgements

Research in our laboratories is supported by the Program for Promotion of Basic Research

Activities for Innovative Biosciences (BRAIN), project grants from the Ministry of Agriculture, Forestry and Fisheries, Japan and Grants-in-Aid from the Ministry of Education, Culture, Sports, Science and Technology of Japan.

## References

- Abe H, Yamaguchi-Shinozaki K, Urao T, Iwasaki T, Hosokawa D, Shinozaki K (1997) Role of *Arabidopsis* MYC and MYB homologs in drought- and abscisic acid-regulated gene expression. *Plant Cell* 9:1859–1868
- Abe H, Urao T, Ito T, Seki M, Shinozaki K, Yamaguchi-Shinozaki K (2003) *Arabidopsis* AtMYC2 (bHLH) and AtMYB2 (MYB) function as transcriptional activators in abscisic acid signaling. *Plant Cell* 15:63–78
- Agarwal M, Hao Y, Kapoor A, Dong CH, Fujii H, Zheng X, Zhu JK (2006) A R2R3 type MYB transcription factor is involved in the cold regulation of CBF genes and in acquired freezing tolerance. *J Biol Chem* 281:37636–37645
- Anderson JP, Badruzaufari E, Schenk PM, Manners JM, Desmond OJ, Ehlert C, Maclean DJ, Ebert PR, Kazan K (2004) Antagonistic interaction between abscisic acid and jasmonate-ethylene signaling pathways modulates defense gene expression and disease resistance in *Arabidopsis*. *Plant Cell* 16:3460–3479
- Baker SS, Wilhelm KS, Thomashow MF (1994) The 5'-region of *Arabidopsis thaliana cor15a* has cis-acting elements that confer cold-, drought- and ABA-regulated gene expression. *Plant Mol Biol* 24:701–713
- Bartels D, Sunkar R (2005) Drought and salt tolerance in plants. *Crit Rev Plant Sci* 24:23–58
- Bensmihen S, Rippa S, Lambert G, Jublot D, Pautot V, Granier F, Giraudat J, Parcy F (2002) The homologous ABI5 and EEL transcription factors function antagonistically to fine-tune gene expression during late embryogenesis. *Plant Cell* 14:1391–1403
- Boter M, Ruiz-Rivero O, Abdeen A, Prat S (2004) Conserved MYC transcription factors play a key role in jasmonate signaling both in tomato and *Arabidopsis*. *Genes Dev* 18:1577–1591
- Boudsocq M, Lauriere C (2005) Osmotic signaling in plants: multiple pathways mediated by emerging kinase families. *Plant Physiol* 138:1185–1194
- Boudsocq M, Barbier-Brygoo H, Lauriere C (2004) Identification of nine sucrose nonfermenting 1-related protein kinases 2 activated by hyperosmotic and saline stresses in *Arabidopsis thaliana*. *J Biol Chem* 279:41758–41766
- Casaretto J, Ho TH (2003) The transcription factors HvABI5 and HvVP1 are required for the abscisic acid induction of gene expression in barley aleurone cells. *Plant Cell* 15:271–284
- Chinnusamy V, Ohta M, Kanrar S, Lee BH, Hong X, Agarwal M, Zhu JK (2003) ICE1: a regulator of cold-induced



- transcriptome and freezing tolerance in *Arabidopsis*. *Genes Dev* 17:1043–1054
- Chinnusamy V, Schumaker K, Zhu JK (2004) Molecular genetic perspectives on cross-talk and specificity in abiotic stress signalling in plants. *J Exp Bot* 55:225–236
- Chinnusamy V, Zhu J, Zhu JK (2006) Gene regulation during cold acclimation in plants. *Physiol Plant* 126:52–61
- Choi H, Hong J, Ha J, Kang J, Kim SY (2000) ABFs, a family of ABA-responsive element binding factors. *J Biol Chem* 275:1723–1730
- Choi DW, Rodriguez EM, Close TJ (2002) Barley *Cbf3* gene identification, expression pattern, and map location. *Plant Physiol* 129:1781–1787
- Dong CH, Agarwal M, Zhang Y, Xie Q, Zhu JK (2006) The negative regulator of plant cold responses, HOS1, is a RING E3 ligase that mediates the ubiquitination and degradation of ICE1. *Proc Natl Acad Sci USA* 103:8281–8286
- Dubouzet JG, Sakuma Y, Ito Y, Kasuga M, Dubouzet EG, Miura S, Seki M, Shinozaki K, Yamaguchi-Shinozaki K (2003) OsDREB genes in rice, *Oryza sativa* L., encode transcription activators that function in drought-, high salt- and cold-responsive gene expression. *Plant J* 33:751–763
- Finkelstein RR, Lynch TJ (2000) The Arabidopsis abscisic acid response gene *ABI5* encodes a basic leucine zipper transcription factor. *Plant Cell* 12:599–609
- Fowler S, Thomashow MF (2002) Arabidopsis transcriptome profiling indicates that multiple regulatory pathways are activated during cold acclimation in addition to the CBF cold response pathway. *Plant Cell* 14:1675–1690
- Fujii H, Verslues PE, Zhu JK (2007) Identification of two protein kinases required for abscisic acid regulation of seed germination, root growth, and gene expression in *Arabidopsis*. *Plant Cell* 19:485–494
- Fujita M, Fujita Y, Maruyama K, Seki M, Hiratsu K, Ohme-Takagi M, Tran LS, Yamaguchi-Shinozaki K, Shinozaki K (2004) A dehydration-induced NAC protein, RD26, is involved in a novel ABA-dependent stress-signaling pathway. *Plant J* 39:863–876
- Fujita Y, Fujita M, Satoh R, Maruyama K, Parvez MM, Seki M, Hiratsu K, Ohme-Takagi M, Shinozaki K, Yamaguchi-Shinozaki K (2005) AREB1 is a transcription activator of novel ABRE-dependent ABA-signaling that enhances drought stress tolerance in *Arabidopsis*. *Plant Cell* 17:3470–3488
- Furihata T, Maruyama K, Fujita Y, Umezawa T, Yoshida R, Shinozaki K, Yamaguchi-Shinozaki K (2006) ABA-dependent multisite phosphorylation regulates the activity of a transcription activator AREB1. *Proc Natl Acad Sci USA* 103:1988–1993
- Gao MJ, Allard G, Byass L, Flanagan AM, Singh J (2002) Regulation and characterization of four CBF transcription factors from *Brassica napus*. *Plant Mol Biol* 49:459–471
- Gilmour SJ, Sebolt AM, Salazar MP, Everard JD, Thomashow MF (2000) Overexpression of the Arabidopsis *CBF3* transcriptional activator mimics multiple biochemical changes associated with cold acclimation. *Plant Physiol* 124:1854–1865
- Haake V, Cook D, Riechmann JL, Pineda O, Thomashow MF, Zhang JZ (2002) Transcription factor CBF4 is a regulator of drought adaptation in Arabidopsis. *Plant Physiol* 130:639–648
- Hobo T, Kowyama Y, Hattori T (1999a) A bZIP factor, TRAB1, interacts with VP1 and mediates abscisic acid-induced transcription. *Proc Natl Acad Sci USA* 96:15348–15353
- Hobo T, Asada M, Kowyama Y, Hattori T (1999b) ACGT-containing abscisic acid response element (ABRE) and coupling element 3 (CE3) are functionally equivalent. *Plant J* 19:679–689
- Hsieh TH, Lee JT, Yang PT, Chiu LH, Charng YY, Wang YC, Chan MT (2002a) Heterology expression of the Arabidopsis C-repeat/dehydration response element binding factor 1 gene confers elevated tolerance to chilling and oxidative stresses in transgenic tomato. *Plant Physiol* 129:1086–1094
- Hsieh TH, Lee JT, Chang YY, Chan MT (2002b) Tomato plants ectopically expressing Arabidopsis CBF1 show enhanced resistance to water deficit stress. *Plant Physiol* 130:618–626
- Hu H, Dai M, Yao J, Xiao B, Li X, Zhang Q, Xiong L (2006) Overexpressing a NAM, ATAF, and CUC (NAC) transcription factor enhances drought resistance and salt tolerance in rice. *Proc Natl Acad Sci USA* 35:12987–12992
- Hu H, You J, Fang Y, Zhu X, Qi Z, Xiong L (2008) Characterization of transcription factor gene SNAC2 conferring cold and salt tolerance in rice. *Plant Mol Biol* 67:169–181
- Ingram J, Bartels D (1996) The molecular basis of dehydration tolerance in plants. *Annu Rev Plant Physiol Plant Mol Biol* 47:377–403
- Ishitani M, Xiong L, Lee H, Stevenson B, Zhu JK (1998) *HOS1*, a genetic locus involved in cold-responsive gene expression in Arabidopsis. *Plant Cell* 10:1151–1161
- Ito Y, Katsura K, Maruyama K, Taji T, Kobayashi M, Seki M, Shinozaki K, Yamaguchi-Shinozaki K (2006) Functional analysis of rice DREB1/CBF-type transcription factors involved in cold-responsive gene expression in transgenic rice. *Plant Cell Physiol* 47:141–153
- Jaglo KR, Kleff S, Amundsen KL, Zhang X, Haake V, Zhang JZ, Deits T, Thomashow MF (2001) Components of the Arabidopsis C-repeat/dehydration-responsive element binding factor cold-response pathway are conserved in *Brassica napus* and other plant species. *Plant Physiol* 127:910–917
- Jaglo-Ottosen KR, Gilmour SJ, Zarka DG, Schabenberger O, Thomashow MF (1998) Arabidopsis CBF1 overexpression induces cor genes and enhances freezing tolerance. *Science* 280:104–106
- Jakoby M, Weisshaar B, Dröge-Laser W, Vicente-Carbajosa J, Tiedemann J, Kroj T, Parcy F, the bZIP Research Group (2002) bZIP transcription factors in *Arabidopsis*. *Trends Plant Sci.* 7:106–111
- Johnson ES (2004) Protein modification by SUMO. *Annu Rev Biochem* 73:355–382

- Jiang C, Iu B, Singh J (1996) Requirement of a CCGAC *cis*-acting element for cold induction of the BN115 gene from winter *Brassica napus*. *Plant Mol Biol* 30:679–684
- Kagaya Y, Hobo T, Murata M, Ban A, Hattori T (2002) Abscisic acid-induced transcription is mediated by phosphorylation of an abscisic acid response element binding factor, TRAB1. *Plant Cell* 14:3177–3189
- Kang JY, Choi HI, Im MY, Kim SY (2002) Arabidopsis basic leucine zipper proteins that mediate stress-responsive abscisic acid signaling. *Plant Cell* 14:343–357
- Kasuga M, Liu Q, Miura S, Yamaguchi-Shinozaki K, Shinozaki K (1999) Improving plant drought, salt and freezing tolerance by gene transfer of a single stress-inducible transcription factor. *Nat Biotechnol* 17:287–291
- Kasuga M, Miura S, Shinozaki K, Yamaguchi-Shinozaki K (2004) A combination of the Arabidopsis DREB1A gene and stress-inducible *rd29A* promoter improved drought- and low-temperature stress tolerance in tobacco by gene transfer. *Plant Cell Physiol* 45:346–350
- Kim S, Kang JY, Cho DI, Park JH, Kim SY (2004) ABF2, an ABRE-binding bZIP factor, is an essential component of glucose signaling and its over-expression affects multiple stress tolerance. *Plant J* 40:75–87
- Kitashiba H, Ishizaka T, Isuzugawa K, Nishimura K, Suzuki T (2004) Expression of a sweet cherry DREB1/CBF ortholog in *Arabidopsis* confers salt and freezing tolerance. *J Plant Physiol* 161:1171–1176
- Kobayashi Y, Yamamoto S, Minami H, Kagaya Y, Hattori T (2004) Differential activation of the rice sucrose nonfermenting1-related protein kinase2 family by hyperosmotic stress and abscisic acid. *Plant Cell* 16:1163–1177
- Kobayashi Y, Murata M, Minami H, Yamamoto S, Kagaya Y, Hobo T, Yamamoto A, Hattori T (2005) Abscisic acid-activated SNRK2 protein kinases function in the gene-regulation pathway of ABA signal transduction by phosphorylating ABA response element-binding factors. *Plant J* 44:939–949
- Koornneef M, Reuling G, Karssen CM (1984) The isolation and characterization of abscisic acid-insensitive mutants of *Arabidopsis thaliana*. *Physiol Plant* 61:377–383
- Koornneef M, Jorna ML, Brinkhorst-van der Swan DLC, Karssen CM (1992) The isolation of abscisic acid (ABA)-deficient mutants by selection of induced revertants in non-germinating gibberellin sensitive lines of *Arabidopsis thaliana* (L.) Heynh. *Theor Appl Genet* 61:383–393
- Kreps JA, Wu Y, Chang HS, Zhu T, Wang X, Harper JF (2002) Transcriptome changes for *Arabidopsis* in response to salt, osmotic, and cold stress. *Plant Physiol* 130:2129–2141
- Lee BH, Henderson DA, Zhu JK (2005) The *Arabidopsis* cold-responsive transcriptome and its regulation by ICE1. *Plant Cell* 17:3155–3175
- Lee H, Xiong L, Gong Z, Ishitani M, Stevenson B, Zhu JK (2001) The *Arabidopsis* *HOS1* gene negatively regulates cold signal transduction and encodes a RING finger protein that displays cold-regulated nucleo-cytoplasmic partitioning. *Genes Dev* 15:912–924
- Lee J, Nam J, Park HC, Na G, Miura K, Jin JB, Yoo CY, Baek D, Kim DH, Jeong JC, Kim D, Lee SY, Salt DE, Mengiste T, Gong Q, Ma S, Bohnert HJ, Kwak SS, Bressan RA, Hasegawa PM, Yun DJ (2007) Salicylic acid-mediated innate immunity in *Arabidopsis* is regulated by SIZ1 SUMO E3 ligase. *Plant J* 49:79–90
- Li J, Wang XQ, Watson MB, Assmann SM (2000) Regulation of abscisic acid-induced stomatal closure and anion channels by guard cell AAPK kinase. *Science* 287:300–303
- Liu Q, Kasuga M, Sakuma Y, Abe H, Miura S, Yamaguchi-Shinozaki K, Shinozaki K (1998) Two transcription factors, DREB1 and DREB2, with an EREBP/AP2 DNA binding domain separate two cellular signal transduction pathways in drought- and low-temperature-responsive gene expression, respectively, in *Arabidopsis*. *Plant Cell* 10:1391–1406
- Lopez-Molina L, Chua NH (2000) A null mutation in a bZIP factor confers ABA-insensitivity in *Arabidopsis thaliana*. *Plant Cell Physiol* 41:541–547
- Lorenzo O, Chico JM, Sanchez-Serrano JJ, Solano R (2004) *JASMONATE-INSENSITIVE1* encodes a MYC transcription factor essential to discriminate between different jasmonate-regulated defense responses in *Arabidopsis*. *Plant Cell* 16:1938–1950
- Magome H, Yamaguchi S, Hanada A, Kamiya Y, Oda K (2004) *Dwarf and delayed-flowering 1*, a novel *Arabidopsis* mutant deficient in gibberellin biosynthesis because of over-expression of a putative AP2 transcription factor. *Plant J* 37:720–729
- Maruyama K, Sakuma Y, Kasuga M, Ito Y, Seki M, Goda H, Shimada Y, Yoshida S, Shinozaki K, Yamaguchi-Shinozaki K (2004) Identification of cold-inducible downstream genes of the *Arabidopsis* DREB1A/CBF3 transcriptional factor using two microarray systems. *Plant J* 38:982–993
- Miura K, Rus A, Sharkhuu A, Yokoi S, Karthikeyan AS, Raghothama KG, Baek D, Koo YD, Jin JB, Bressan RA, Yun DJ, Hasegawa PM (2005) The *Arabidopsis* SUMO E3 ligase SIZ1 controls phosphate deficiency responses. *Proc Natl Acad Sci USA* 102:7760–7765
- Miura K, Jin JB, Lee J, Yoo CY, Stirn V, Miura T, Ashworth EN, Bressan RA, Yun DJ, Hasegawa PM (2007) SIZ1-mediated sumoylation of ICE1 controls *CBF3/DREB1A* expression and freezing tolerance in *Arabidopsis*. *Plant Cell* 19:1403–1414
- Mustilli AC, Merlot S, Vavasseur A, Fenzi F, Giraudat J (2002) *Arabidopsis* OST1 protein kinase mediates the regulation of stomatal aperture by abscisic acid and acts upstream of reactive oxygen species production. *Plant Cell* 14:3089–3099
- Nakashima K, Yamaguchi-Shinozaki K (2005) Molecular studies on stress-responsive gene expression in *Arabidopsis* and improvement of stress tolerance in crop plants by regulon biotechnology. *Jpn Agr Res Q* 39:221–222
- Nakashima K, Yamaguchi-Shinozaki K (2006) Regulons involved in osmotic stress-responsive and cold stress-responsive gene expression in plants. *Physiol Plantarum* 126:62–71

- Nakashima K, Kiyosue T, Yamaguchi-Shinozaki K, Shinozaki K (1997) A nuclear gene, *erd1*, encoding a chloroplast-targeted Clp protease regulatory subunit homolog is not only induced by water stress but also developmentally upregulated during senescence in *Arabidopsis thaliana*. *Plant J* 12:851–861
- Nakashima K, Shinwari ZK, Sakuma Y, Seki M, Miura S, Shinozaki K, Yamaguchi-Shinozaki K (2000) Organization and expression of two *Arabidopsis* DREB2 genes encoding DRE-binding proteins involved in dehydration and high-salinity-responsive gene expression. *Plant Mol Biol* 42:657–665
- Nakashima K, Fujita Y, Katsura K, Maruyama K, Narusaka Y, Seki M, Shinozaki K, Yamaguchi-Shinozaki K (2006) Transcriptional regulation of ABI3- and ABA-responsive genes including *RD29B* and *RD29A* in seeds, germinating embryos, and seedlings of *Arabidopsis*. *Plant Mol Biol* 60:51–68
- Nakashima K, Tran LS, Van Nguyen D, Fujita M, Maruyama K, Todaka D, Ito Y, Hayashi N, Shinozaki K, Yamaguchi-Shinozaki K (2007) Functional analysis of a NAC-type transcription factor OsNAC6 involved in abiotic and biotic stress-responsive gene expression in rice. *Plant J* 51:617–630
- Narusaka Y, Nakashima K, Shinwari ZK, Sakuma Y, Furihata T, Abe H, Narusaka M, Shinozaki K, Yamaguchi-Shinozaki K (2003) Interaction between two *cis*-acting elements, ABRE and DRE, in ABA-dependent expression of *Arabidopsis rd29A* gene in response to dehydration and high-salinity stresses. *Plant J* 34:137–148
- Novillo F, Alonso JM, Ecker JR, Salinas J (2004) CBF2/DREB1C is a negative regulator of CBF1/DREB1B and CBF3/DREB1A expression and plays a central role in stress tolerance in *Arabidopsis*. *Proc Natl Acad Sci USA* 101:3985–3990
- Oh SJ, Song SI, Kim YS, Jang HJ, Kim SY, Kim M, Kim YK, Nahm BH, Kim JK (2005) *Arabidopsis* CBF3/DREB1A and ABF3 in transgenic rice increased tolerance to abiotic stress without stunting growth. *Plant Physiol* 138:341–351
- Ohnishi T, Sugahara S, Yamada T, Kikuchi K, Yoshiba Y, Hirano HY, Tsutsumi N (2005) OsNAC6, a member of the NAC gene family, is induced by various stresses in rice. *Genes Genet Syst* 80:135–139
- Ooka H, Satoh K, Doi K, Nagata T, Otomo Y, Murakami K, Matsubara K, Osato N, Kawai J, Carninci P, Hayashizaki Y, Suzuki K, Kojima K, Takahara Y, Yamamoto K, Kikuchi S (2003) Comprehensive analysis of NAC family genes in *Oryza sativa* and *Arabidopsis thaliana*. *DNA Res* 20:239–247
- Ouellet F, Vazquez-Tello A, Sarhan F (1998) The wheat *wcs120* promoter is cold-inducible in both monocotyledonous and dicotyledonous species. *FEBS Lett* 423:324–328
- Pellegrineschi A, Reynolds M, Pacheco M, Brito RM, Almeraya R, Yamaguchi-Shinozaki K, Hoisington D (2004) Stress-induced expression in wheat of the *Arabidopsis thaliana* DREB1A gene delays water stress symptoms under greenhouse conditions. *Genome* 47:493–500
- Qin F, Sakuma Y, Li J, Liu Q, Li YQ, Shinozaki K, Yamaguchi-Shinozaki K (2004) Cloning and functional analysis of a novel DREB1/CBF transcription factor involved in cold-responsive gene expression in *Zea mays* L. *Plant Cell Physiol* 45:1042–1052
- Qin F, Kakimoto M, Sakuma Y, Maruyama K, Osakabe Y, Tran LS, Shinozaki K, Yamaguchi-Shinozaki K (2007) Regulation and functional analysis of ZmDREB2A in response to drought and heat stresses in *Zea mays* L. *Plant J* 50:54–69
- Qin F, Sakuma Y, Tran LS, Maruyama K, Kidokoro S, Fujita Y, Fujita M, Umezawa T, Sawano Y, Miyazono KI, Tanokura M, Shinozaki K, Yamaguchi-Shinozaki K (2008) *Arabidopsis* DREB2A-interacting proteins function as RING E3 ligases and negatively regulate plant drought stress-responsive gene expression. *Plant Cell* 20:1693–1707
- Rabbani MA, Maruyama K, Abe H, Khan MA, Katsura K, Ito Y, Yoshiwara K, Seki M, Shinozaki K, Yamaguchi-Shinozaki K (2003) Monitoring expression profiles of rice genes under cold, drought, and high-salinity stresses and abscisic acid application using cDNA microarray and RNA gel-blot analyses. *Plant Physiol* 133:1755–1767
- Sakamoto H, Maruyama K, Sakuma Y, Meshi T, Iwabuchi M, Shinozaki K, Yamaguchi-Shinozaki K (2004) *Arabidopsis* Cys2/His2-type zinc-finger proteins function as transcription repressors under drought-, cold- and high-salinity-stress conditions. *Plant Physiol* 136:2734–2746
- Sakuma Y, Liu Q, Dubouzet JG, Abe H, Shinozaki K, Yamaguchi-Shinozaki K (2002) DNA-binding specificity of the ERF/AP2 domain of *Arabidopsis* DREBs, transcription factors involved in dehydration- and cold-inducible gene expression. *Biochem Biophys Res Commun* 290:998–1009
- Sakuma Y, Maruyama K, Osakabe Y, Qin F, Seki M, Shinozaki K, Yamaguchi-Shinozaki K (2006a) Functional analysis of an *Arabidopsis* transcription factor, DREB2A, involved in drought-responsive gene expression. *Plant Cell* 18:1292–1309
- Sakuma Y, Maruyama K, Qin F, Osakabe Y, Shinozaki K, Yamaguchi-Shinozaki K (2006b) Dual function of an *Arabidopsis* transcription factor DREB2A in water-stress-responsive and heat-stress-responsive gene expression. *Proc Natl Acad Sci USA* 103:18822–18827
- Schramm F, Larkindale J, Kiehlmann E, Ganguli A, English G, Vierling E, von Koskull-Döring P (2008) A cascade of transcription factor DREB2A and heat stress transcription factor HsfA3 regulates the heat stress response of *Arabidopsis*. *Plant J* 53:264–274
- Seki M, Narusaka M, Abe H, Kasuga M, Yamaguchi-Shinozaki K, Carninci P, Hayashizaki Y, Shinozaki K (2001) Monitoring the expression pattern of 1300 *Arabidopsis* genes

- under drought and cold stresses by using a full-length cDNA microarray. *Plant Cell* 13:61–72
- Seki M, Narusaka M, Ishida J, Nanjo T, Fujita M, Oono Y, Kamiya A, Nakajima M, Enju A, Sakurai T, Satou M, Akiyama K, Taji T, Yamaguchi-Shinozaki K, Carninci P, Kawai J, Hayashizaki Y, Shinozaki K (2002) Monitoring the expression profiles of 7000 *Arabidopsis* genes under drought, cold and high-salinity stresses using a full-length cDNA microarray. *Plant J* 31:279–292
- Shen Q, Ho TH (1995) Functional dissection of an abscisic acid (ABA)-inducible gene reveals two independent ABA-responsive complexes each containing a G-box and a novel *cis*-acting element. *Plant Cell* 7:295–307
- Shen Q, Zhang P, Ho TH (1996) Modular nature of abscisic acid (ABA) response complexes: composite promoter units, which are necessary and sufficient for ABA induction of gene expression in barley. *Plant Cell* 8:1107–1119
- Shen YG, Zhang WK, He SJ, Zhang JS, Liu Q, Chen SY (2003a) An EREBP/AP2-type protein in *Triticum aestivum* was a DRE-binding transcription factor induced by cold, dehydration and ABA stress. *Theor Appl Genet* 106:923–930
- Shen YG, Zhang WK, Yan DQ, Du BX, Zhang JS, Liu Q, Chen SY (2003b) Characterization of a DRE-binding transcription factor from a halophyte *Atriplex hortensis*. *Theor Appl Genet* 107:155–61
- Shinozaki K, Yamaguchi-Shinozaki K (2000) Molecular responses to dehydration and low temperature: differences and cross-talk between two stress signaling pathways. *Curr Opin Plant Biol* 3:217–223
- Shinozaki K, Yamaguchi-Shinozaki K, Seki M (2003) Regulatory network of gene expression in the drought and cold stress responses. *Curr Opin Plant Biol* 6:410–417
- Shinwari ZK, Nakashima K, Miura S, Kasuga M, Seki M, Yamaguchi-Shinozaki K, Shinozaki K (1998) An *Arabidopsis* gene family encoding DRE/CRT binding proteins involved in low-temperature-responsive gene expression. *Biochem Biophys Res Commun* 250:161–170
- Simpson SD, Nakashima K, Narusaka Y, Seki M, Shinozaki K, Yamaguchi-Shinozaki K (2003) Two different novel *cis*-acting elements of *erd1*, a *clpA* homologous *Arabidopsis* gene function in induction by dehydration stress and dark-induced senescence. *Plant J* 33:259–270
- Stockinger EJ, Gilmour SJ, Thomashow MF (1997) *Arabidopsis thaliana* *CBF1* encodes an AP2 domain-containing transcription activator that binds to the C-repeat/DRE, a *cis*-acting DNA regulatory element that stimulates transcription in response to low temperature and water deficit. *Proc Natl Acad Sci USA* 94:1035–1040
- Sunkar R, Chinnusamy V, Zhu J, Zhu JK (2007) Small RNAs as big players in plant abiotic stress responses and nutrient deprivation. *Trends Plant Sci* 12:301–309
- Thomashow MF (1999) Plant cold acclimation: freezing tolerance genes and regulatory mechanisms. *Annu Rev Plant Physiol Plant Mol Biol* 50:571–599
- Tran LS, Nakashima K, Sakuma Y, Simpson SD, Fujita Y, Maruyama K, Fujita M, Seki M, Shinozaki K, Yamaguchi-Shinozaki K (2004) Isolation and functional analysis of *Arabidopsis* stress-inducible NAC transcription factors that bind to a drought-responsive *cis*-element in the *early responsive to dehydration stress 1* promoter. *Plant Cell* 16:2482–2498
- Tran LS, Nakashima K, Sakuma Y, Osakabe Y, Qin F, Simpson SD, Maruyama K, Fujita Y, Shinozaki K, Yamaguchi-Shinozaki K (2007a) Co-expression of the stress-inducible zinc finger homeodomain ZFHD1 and NAC transcription factors enhances expression of the *ERD1* gene in *Arabidopsis*. *Plant J* 49:46–63
- Tran LS, Nakashima K, Shinozaki K, Yamaguchi-Shinozaki K (2007b) Plant gene networks in osmotic stress response: from genes to regulatory networks. *Methods Enzymol* 428:109–128
- Uno Y, Furihata T, Abe H, Yoshida R, Shinozaki K, Yamaguchi-Shinozaki K (2000) *Arabidopsis* basic leucine zipper transcription factors involved in an abscisic acid-dependent signal transduction pathway under drought and high-salinity conditions. *Proc Natl Acad Sci USA* 97:11632–11637
- Vagujfalvi A, Galiba G, Cattivelli L, Dubcovsky J (2003) The cold-regulated transcriptional activator Cbf3 is linked to the frost-tolerance locus Fr-A2 on wheat chromosome 5A. *Mol Genet Genomics* 269:60–67
- Vogel JT, Zarka DG, Van Buskirk HA, Fowler SG, Thomashow MF (2005) Roles of the CBF2 and ZAT12 transcription factors in configuring the low temperature transcriptome of *Arabidopsis*. *Plant J* 41:195–211
- Xiong L, Schumaker KS, Zhu JK (2002) Cell signaling during cold, drought, and salt stress. *Plant Cell* 14(Suppl.):S165–S183
- Xue GP (2003) The DNA-binding activity of an AP2 transcriptional activator HvCBF2 involved in regulation of low-temperature responsive genes in barley is modulated by temperature. *Plant J* 33:373–383
- Yadav V, Mallappa C, Gangappa SN, Bhatia S, Chattopadhyay S (2005) A basic helix-loop-helix transcription factor in *Arabidopsis*, MYC2, acts as a repressor of blue light-mediated photomorphogenic growth. *Plant Cell* 17:1953–1966
- Yamaguchi-Shinozaki K, Shinozaki K (1992) A novel *Arabidopsis* DNA binding protein contains the conserved motif of HMG-box proteins. *Nucleic Acids Res* 20:6737
- Yamaguchi-Shinozaki K, Shinozaki K (1994) A novel *cis*-acting element in an *Arabidopsis* gene is involved in responsiveness to drought, low temperature or high-salt stress. *Plant Cell* 6:251–264
- Yamaguchi-Shinozaki K, Shinozaki K (2005) Organization of *cis*-acting regulatory elements in osmotic- and cold-stress-responsive promoters. *Trends Plant Sci* 10:88–94
- Yoo CY, Miura K, Jin JB, Lee J, Park HC, Salt DE, Yun DJ, Bressan RA, Hasegawa PM (2006) SIZ1 small ubiquitin-like



- modifier E3 ligase facilitates basal thermotolerance in *Arabidopsis* independent of salicylic acid. *Plant Physiol* 142:1548–1558
- Yoshida T, Sakuma Y, Todaka D, Maruyama K, Qin F, Mizoi J, Kidokoro S, Fujita Y, Shinozaki K, Yamaguchi-Shinozaki K (2008) Functional analysis of an *Arabidopsis* heat-shock transcription factor HsfA3 in the transcriptional cascade downstream of the DREB2A stress-regulatory system. *Biochem Biophys Res Commun* 368:515–521
- Yoshida R, Hobo T, Ichimura K, Mizoguchi T, Takahashi F, Aronso J, Ecker JR, Shinozaki K (2002) ABA-activated SnRK2 protein kinase is required for dehydration stress signaling in *Arabidopsis*. *Plant Cell Physiol* 43:1473–1483
- Zhang JZ, Creelman RA, Zhu JK (2004) From laboratory to field: Using information from *Arabidopsis* to engineer salt, cold and drought tolerance in crops. *Plant Physiol* 135:615–621
- Zhu J, Dong CH, Zhu JK (2007) Interplay between cold-responsive gene regulation, metabolism and RNA processing during plant cold acclimation. *Curr Opin Plant Biol* 10:290–295
- Zhu JK (2002) Salt and drought stress signal transduction in plants. *Annu Rev Plant Biol* 53:247–273

# Chapter 11

## Epigenetic Regulation: Chromatin Modeling and Small RNAs

Viswanathan Chinnusamy

*Water Technology Centre, Indian Agricultural Research Institute, New Delhi, India*

Jian-Kang Zhu\*

*Department of Botany and Plant Sciences, University of California, 2150 Batchelor Hall,  
Riverside, CA 92521, USA*

Summary .....	218
I Introduction .....	219
II Epigenetics .....	219
A Chromatin Modeling.....	220
1 Histone Code .....	220
2 DNA Methylation .....	223
3 Interaction Between Histone Code and DNA Methylation.....	228
III Abiotic Stress-Induced Epigenetic Changes.....	230
A Abiotic Stress-Induced Changes in Histone Code .....	230
B Regulation of DNA Methylation by Abiotic Stresses .....	233
C siRNAs in Abiotic Stresses .....	234
D Transgeneration Stress Memory .....	234
IV Conclusions and Perspectives.....	235
Acknowledgements .....	236
References .....	236

---

\*Author for correspondence, e-mail: [jian-kang.zhu@ucr.edu](mailto:jian-kang.zhu@ucr.edu)

## Summary

Epigenetic mechanisms, namely histone modifications and DNA methylation induced changes in the chromatin, give rise to epigenomes, which add diversity and complexity to the genome of organisms. Epigenetic modifications play a pivotal role in genomic imprinting, paramutation, defense against transposon proliferation and regulation of gene expression. Specific combinations of histone N-tail modifications can be considered a histone code, which determines the chromatin structure and thus regulates transcription. Cytosine methylation of DNA is a ubiquitous epigenetic mark in diverse species. Asymmetric methylation is re-established after every mitosis cycle, whereas symmetric methylation can be maintained through mitosis and may even be transmitted through meiosis. Abiotic stresses and plant hormones induce epigenetic changes, which can lead to altered gene expression and recombination. ABA induces chromatin remodeling by histone H3 acetylation and methylation to regulate gene expression and abiotic stress-induced growth arrest. Submergence-stress induces the expression of alcohol dehydrogenase (*ADH1*) and pyruvate decarboxylase (*PDC1*) genes in rice through histone H3 trimethylation and acetylation. Further, *Arabidopsis* HOS15, a component of the chromatin repression complex involved in histone deacetylation, plays a key role in freezing stress tolerance. Besides these histone modifications, abiotic stresses also induce a change in DNA methylation. Cold, osmotic, salt, heavy-metal stresses and plant hormones can induce DNA demethylation or hypermethylation at specific loci. Abiotic stresses and plant hormones may also induce the transposition of transposons through DNA hypomethylation. Small RNAs can guide posttranscriptional or transcriptional gene silencing. Stresses like UV-C radiation or the biotic factor – flagellin induces a high frequency of somatic homologous recombination in *Arabidopsis* and this change is transmitted meiotically across generations probably through epigenetic processes such as DNA hypomethylation. Stress memory, through the epigenetic process, might help plants more effectively combat subsequent incidences of stresses within a generation and might confer an adaptive advantage when meiotically inherited. Further studies on abiotic stress regulated epigenetic processes will help to better understand abiotic stress tolerance of plants.

**Keywords** abiotic stress • demethylation • DNA methylation • histone modification • SiRNAs • stress memory

---

**Abbreviations:** ADH – alcohol dehydrogenase ; ChIP – chromatin immunoprecipitation ; CMTs – chromomethylases ; DCL1 – dicer-like-1 ; ddm1 – decreased DNA methylation-1 ; DNMT – de novo DNA methyltransferase ; DRM – domains rearranged methylase ; FLC – flowering locus ; HATs – histone acetyltransferases ; HDACs – histone deacetylases ; hos – high expression of osmotically responsive genes ; HP1 – heterochromatin Protein-1 ; HYL1 – hyponastic leaves-1 ; MALDI-TOF – matrix-assisted laser desorption ionization-time of flight mass spectrometry ; MARH – mono-ADP-ribose-protein hydrolase ; MART – mono-ADP-ribosyl transferase ; MeDIP – methylated DNA immuno-precipitation ; MIR – miRNA genes ; MSAP – methylation-sensitive amplified polymorphism ; MS-HRM – methylation sensitive-high resolution melting ; MSP – methylation specific PCR ; MS-SnuPE – methylation

sensitive-single nucleotide primer extension ; MS-SSCA – methylation-sensitive single-strand conformation analysis ; NAT – natural *cis*-antisense ; nat-siRNAs – NAT-generated siRNAs ; P5CDH – pyrroline-5-carboxylate dehydrogenase ; Pc-G/Trx-G – polycomb-trithorax group protein ; PDC – pyruvate decarboxylase ; RdDM – RNA-directed DNA methylation ; RDRs – RNA-dependent RNA polymerases ; RISC – RNA-induced silencing complex ; RITS – RNA interference (RNAi)-induced transcriptional silencing ; ROS1 – repressor of silencing-1 ; rts1 – RNA-mediated transcriptional silencing-1 ; SAM – S-adenosyl-L-methionine ; SGS3 – suppressor of gene silencing-3 ; sil1 – modifiers of silencing-1 ; siRNA – small interfering RNA ; SUMO – small ubiquitin-related modifier ; ta-siRNAs – trans-acting siRNAs ; TBL1 – transducin beta-like protein-1 ; TGS – transcriptional gene silencing

## I Introduction

Environmental factors such as water, temperature, light and nutrients are necessary for plant growth and development. Scarcity or excess of these factors lead to stress in plants. Some environmental factors, which are not necessary for plant growth and development, also become stressful to plants when their level exceeds a certain critical amount. These factors include UV-B radiation, unfavorable soil conditions such as soil salinity, alkalinity, sodicity, acidity and toxic metals, poor-quality irrigation and air pollutants (e.g., ozone). The term abiotic stress encompasses stress caused by the environmental factors. Abiotic stresses adversely affect survival and reproduction of plants, thus limiting the temporal and spatial distribution of plant species. These stresses exert evolutionary pressure on plants, and plants have evolved genetic and epigenetic mechanisms to combat abiotic stresses. Genetic mechanisms contributing to abiotic stress resistance such as stress escape, avoidance and tolerance have been studied extensively.

Significant progress has been made in understanding the molecular genetic basis of abiotic stress tolerance (Chinnusamy et al. 2004, 2007; Yamaguchi and Blumwald 2005; Bohnert et al. 2006; Yamaguchi-Shinozaki and Shinozaki 2006; Sunkar et al. 2007; Zhu et al. 2007a). However, the study of epigenetic mechanisms in abiotic stress resistance of plants is in its infancy. Genome imprinting in mammals and plants (Scott and Spielman 2006; Feil and Berger 2007), transcriptional gene silencing (TGS) induced by transgenes in animals and plants (Vaucheret and Fagard 2001; Gong et al. 2002; Morris et al. 2004), paramutation in plants and mice (Alleman et al. 2006; Rassoulzadegan et al. 2006), and X-chromosome inactivation in animals (Chow et al. 2005) are some of the well-known examples of epigenetic phenomena. This chapter aims to introduce epigenetic mechanisms and their potential role in abiotic stress tolerance in plants.

## II Epigenetics

Waddington (1939) introduced the term epigenetics (“*epi*,” means “besides,” “upon” or “over”, i.e., the existence of phenomena beyond genetics), derived from epigenesis, which encompasses the

mysterious workings of Nature that allow structure to form *de novo* from the apparent structureless mass that results from the union of egg and sperm. Since then, the concept of epigenetics has undergone several changes. After 6 decades, epigenetics was redefined as “the study of the changes in gene expression that occur in organisms with differentiated cells, and the mitotic inheritance of given patterns of gene expression” and “the study of nuclear inheritance that is not based on differences in DNA sequences” (Holliday 1994). By the end of the twentieth century, epigenetics was defined as the study of changes in gene function that are mitotically and/or meiotically heritable and that do not entail a change in DNA sequence (Wu and Morris 2001). However, the debate is still continuing as whether to relax the stringency of requiring heritability in the definition. An epigenetic event is defined as the structural adaptation of chromosomal regions to register, signal or perpetuate altered activity states. This definition includes chromosomal marks that are transient, as in the case of DNA repair or cell-cycle phases and stable changes maintained across multiple cell generations (Bird 2007).

The genome size and number of protein coding genes are not directly related to the complexity of organisms. Epigenetics adds diversity and complexity to the genome of organisms. Epigenetic process is one of the crucial mechanisms of clonal expansion of single cells to diverse cell types. One genome present in an embryo gives rise to many epigenomes, which results in a multitude of cell fates during development. Genomes are responsive to and regulated by hybridization, polyploidization, developmental and environmental cues through epigenetic processes such as DNA methylation, histone modification, small RNAs and transposable element activity. These epigenetic modifications change the expression but not the transmission of alleles (Jenuwein and Allis 2001). Epigenetics deals with phenotypes due to the modification of a function of a genetic locus without a change in DNA nucleotide sequence. In mammals, epigenetic mechanisms mediated by DNA methylation and the Polycomb-trithorax group (Pc-G/Trx-G) protein complexes meet the criteria of heritable epigenetic variation, whereas in the case of histones, the issue of heritability has yet to be resolved (Bird 2002). Plants also possess the homologs of the Pc-G/Trx complex that regulate epigenetic processes.



Recent advances in molecular and biochemical studies led to the identification of two epigenetic mechanisms that mediate a change in the properties of a genetic locus without modifying nucleotide sequences. These mechanisms are chromatin modeling/remodeling and small interfering RNA (siRNA)-mediated transcriptional gene silencing (TGS).

### A Chromatin Modeling

Chromatin is an organized package of DNA and histone proteins in eukaryotic chromosomes. Chromatin structure is dynamic and is modified during various physiological processes. The basic unit of chromatin is the nucleosome, which consists of about 200 bp DNA, a histone-core complex (H2A, H2B, H3 and H4) and the linker histone H1. The histone-core complex is an octamer consisting of an H3<sub>2</sub>-H4<sub>2</sub> tetramer associated with two H2A-H2B dimers. The complex is wrapped by 146 bp DNA, and the linker DNA associated with H1 varies in length from 8 to 114 bp. The N-terminal regions (20–35 residues) of core histones protrude from the nucleosome bead. The N-terminal tails of core histones are basic in nature (contain positively charged lysine residues), which interact with negatively charged DNA and/or other nucleosomal proteins. The N-terminal tails of core histones undergo various post-translational modifications. Similarly, the cytosine base of DNA also undergoes methylation and demethylation. Thus, chromatin structure depends on post-translational modifications of histones and DNA methylation. A change in chromatin structure achieved by the action of ATP-dependent remodeling complexes is called “chromatin remodeling”. Histone and DNA modifications are critical in chromatin folding (i.e., chromatin modeling and remodeling) and thus determine the functional state of chromatin. Depending on packaging, chromatin is classified into euchromatin and heterochromatin. Euchromatin is a lightly packed structure that allows active transcription, whereas heterochromatin is a tightly packed structure that does not permit transcription (Khorasanizadeh 2004).

#### 1 Histone Code

In *Arabidopsis*, about 50 genes encoding histones (5 H1, 13 H2A, 11 H2B, 13 H3 and 8 H4)

have been identified. Further, the N-tails of the histone core offer about 240 positions for post-translational modifications. The N-tails of H2A, H2B, H3 and H4 undergo post-translational modifications such as acetylation, methylation, glycosylation, phosphorylation, ADP-ribosylation, carbonylation, sumoylation and ubiquitination (Fuchs et al. 2006). These histone variations and post-translational modifications offer enormous combinatorial possibilities for nucleosome assemblies. In plants, histone H1 variants have been studied (Li et al. 1999; Ng et al. 2006), but very little is known about the role of the variants of core-histones. Histone post-translational modifications lead to alterations in chromatin structure and affinity for chromatin-associated proteins and thus regulate the access of underlying DNA to transcription machinery. Since modifications of N-tails of histones extend the information potential of the DNA code and gene regulation, specific combinations of these histone amino-terminal modifications can be considered a “histone code”. The various modifications within one histone and in different histone molecules might be interdependent and can influence each other in synergistic or antagonistic ways. Histone code might act as a “binary switch” (neighboring modifications acting together) or “modification cassettes” (depending upon the modification, modifiable amino acid residues in linear strings can have different biological functions). Thus, histone code determines the expression of the genetic code (Jenuwein and Allis 2001).

#### 1.1 Acetylation

Acetylation occurs on lysine ( $\epsilon$ -amino group) residues of N-tails of H2A (K 4, 5, 7), H2B (K 5, 11, 12, 15, 16, 20), H3 (K 4, 9, 14, 18, 23, 27) and H4 (K 5, 8, 12, 16) (Peterson and Laniel 2005). Histone acetyltransferases (HATs) transfer an acetyl group from acetyl-coenzyme A (acetyl-CoA) to the  $\epsilon$ -amino group of certain lysine side chains within a histones' basic N-terminal tail region (Sterner and Berger 2000). *Arabidopsis* genome encodes 12 HATs belonging to the GCN5-related N-terminal acetyltransferase (GNAT)-MYST family, the p300/CREB-binding protein (CBP) co-activator family and the family related to mammalian TAF<sub>II</sub>250 (Pandey et al. 2002). Lysine acetylation is a reversible process and the acetyl

group is removed from the histone N-tail by histone deacetylases (HDACs) (Khorasanizadeh 2004). *Arabidopsis* genome encodes 16 HDACs belonging to three major families, namely the reduced potassium dependency3 (RPD3)/histone deacetylase1 (HDA1) superfamily, the silent information regulator 2 (SIR2) families and the plant-specific HD2 family (Pandey et al. 2002). The HAT activity of conserved transcriptional regulator GCN5 provides the molecular link between acetylation and transcriptional activation (Brownell et al. 1996). Chromatin-associated proteins with bromodomains (~100-amino acid conserved sequence) recognize acetyllysines of histone N termini (Owen et al. 2000). Acetylation of H3 and H4 tails leads to recruitment of bromodomain-containing transcription complexes (Agalioti et al. 2002). In yeast, the “SAGA” (Spt-Ada-Gcn5-HAT) complex containing GCN5 preferentially modifies nucleosomal histones H3 and H2B (Roth et al. 2001). Acetylation results in recruitment of the ATP-dependent SWI/SNF chromatin-remodeling complex, which “loosens” nucleosomes to let transcription factors gain access to their targets within chromatin. Transcriptional activation appears to be the result of neutralization of the positive charge of the tail region due to acetylation of lysine or recruitment of transcriptional activators with bromodomains. Conversely, deacetylation of histone results in a non-permissive chromatin conformation that prevents transcription (Grant 2001). Genetic screens for release of transgene silencing showed that *hda6* mutation results in loss of transcriptional silencing of repetitive transgenes and endogenous target genes. This finding suggests that HDACs are required for maintenance of transcriptional gene silencing (Probst et al. 2004).

## 1.2 Methylation

Methylation occurs on lysine ( $\epsilon$ -amino group) and arginine (guanidino group) residues of histone tails. It increases the basicity of the side chain of histone N-tails. Mono-, di- and tri-methylation of lysine and mono- and di-methylation of arginine are common in the N-tails of H2A, H2B, H3 and H4. Methylation of histone is linked to transcriptional activation or repression, depending upon the histone, the methylated residue or level (mono-, di- and tri-methylation) of methylation

(Shilatifard 2006). Histone methyltransferases catalyze the methylation of the lysine side chain in the histone N-tail. Histone methyltransferases contain a SET domain (130 amino acids that fold into three discrete  $\beta$  sheet regions flanked by  $\alpha$  helices) and use S-adenosyl-L-methionine (SAM) as a co-factor. Proteins with chromodomain recognize and bind to methyllysines with the highest affinity for trimethyllysine and lowest for monomethyllysine (Khorasanizadeh 2004). Lysine methylation occurs on K4, K9, K27 and K36 of H3, and K20 of H4 (Lachner et al. 2003). Tri-methylation of H3-K4 is associated with transcriptional activation (Santos-Rosa et al. 2002). Conversely, H3-K9 methylation can trigger DNA methylation in *Arabidopsis* (Jackson et al. 2002) and results in silenced chromatin domains (Noma et al. 2001). The arginine in the N termini of histones H3 and H4 also undergoes methylation, which results in transcription activation (Wang et al. 2001). Proteins with the protein-R-methyltransferase (PRMT) domain transfer the methyl group from SAM to the guanidino group of arginines to produce mono-methylarginine or di-methylarginine.

## 1.3 Phosphorylation

Phosphorylation of serine and threonine (hydroxyl group) residues in the N-tail of H2A, H2B, H3 and H4 regulates chromatin structure, activation of transcription, apoptosis and DNA damage repair. Histone phosphorylation is catalyzed by kinases, whereas the enzymes in the protein phosphatase 1 (PP1) family catalyze dephosphorylation. Members of the plant aurora kinase (Ser/Thr kinase) family catalyze histone H3 phosphorylation (Houben et al. 2007). An increase in negative charge due to phosphorylation of N-tails of histones leads to chromatin decondensation. Phosphorylation of Ser10 and Ser28 in H3 activates transcription. Ser10 phosphorylation inhibits K9 methylation and recruits HAT, which catalyzes K9 and K14 acetylation of histone H3 (Jenuwein and Allis 2001). Phosphorylation increases lysine acetylation capacity and might neutralize the effect of lysine methylation when phosphoserines occur adjacent to methyllysines in histone tails (Fischle et al. 2003; Khorasanizadeh 2004), and thus might activate transcription. In *Drosophila*, phosphorylation of Ser10 of H3 activates

transcription during heat shock response (Nowak and Corces 2000).

#### 1.4 ADP-Ribosylation

Mono-ADP-ribosylation occurs on an arginine (guanidino group) residue of H2A, H2B, H3 and H4, and on a glutamic acid (carboxyl group) residue of H1, H2A and H2B in mammalian cells. Mono-ADP-ribosyl transferase (MART) family proteins catalyze the transfer of ADP-ribose moiety of NAD<sup>+</sup> to a specific amino acid of an acceptor protein. The mono-ADP-ribose-protein hydrolase (MARH) family proteins specifically hydrolyze ADP-ribose-arginine bonds to release the free mono-ADP-ribose and regeneration of the guanidino group of arginine. Histones also appear to undergo poly-ADP-ribosylation. However, the effect of mono- or poly-ADP-ribosylation on chromatin structure is not well characterized (Hassa et al. 2006).

#### 1.5 Biotinylation

The vitamin biotin is covalently linked to H1, H2A, H2B, H3 and H4 in a process called biotinylation. Enzymatic biotinylation of synthetic peptides and mass spectrometric studies led to the identification of biotinylation sites on H2A (K9, K13, K125, K127, and K129), H3 (K4, K9, and K18) and H4 (K8 and K12). In the two-step biotinylation reaction, biotinidase (histone biotinyl transferase) cleaves the biocytin (biotin- $\epsilon$ -lysine) and biotinyl-thioester intermediate (cysteine-bound biotin) forms at or near the active site of biotinidase. This biotinyl moiety is then transferred to the  $\epsilon$ -amino group of lysine in histones. Both biotinylation and debiotinylation of histones are probably catalyzed by biotinidase, depending on the microenvironment in chromatin, posttranslational modifications and alternative splicing of biotinidase. Histone biotinylation appears to be important for heterochromatin structures, gene silencing, and chromatin condensation during mitosis and DNA repair. Histone modifications such as acetylation and phosphorylation decrease biotinylation of adjacent lysine residues. In contrast, biotinylation is enhanced by dimethylation of arginine residues (Kothapalli et al. 2005). Similar to K9-dimethylated histone H3, the known marker for heterochromatin, K12 biotinylated H4 is also found to be enriched in heterochromatin. Conversely, depletion of K12 biotinylation of H4

in the interleukin-2 gene promoter results in transcriptional activation in humans. These results suggest that biotinylation of histone leads to suppression of gene expression (Camporeale et al. 2007). Interestingly, biotinylation appears to regulate the stress response in *Drosophila*. Growing *Drosophila* on biotin-deficient diet for 12 generations followed by normal diet for two generations resulted in increased heat stress resistance and lifespan, potentially through epigenetic modification (Smith et al. 2007).

#### 1.6 Ubiquitination

Regulated proteolysis plays a crucial role in cellular functions during growth and development. Ubiquitin is covalently attached to a target protein through an isopeptide bond between its C-terminal glycine and the  $\epsilon$ -amino group of a lysine residue on the acceptor protein by an ubiquitin E3-ligase. Ubiquitin E3-ligases provide substrate specificity to the 26S proteasome degradation pathway through recognition of substrate for polyubiquitination. In yeast, H2B K123 ubiquitination is required for dimethylation of H3 K4 or K79. Lysine residues of histones H2A (K119) and H2B (K120, K123) are ubiquitinated. Ubiquitination of lysine in histones plays a crucial role in positive regulation of transcription (Y. Zhang 2003). A suppressor screen for *ros1* (repressor of silencing-1) led to the identification of the *sup32-1* mutant, in which silencing of the *RD29A::LUC* transgene and endogenous *RD29A* gene was partially released due to reduction in CpNpG and CpNpNp methylation in the gene promoters. The *SUP32* locus encodes an Ubiquitin-specific protease (UBP26), which specifically cleaves ubiquitin C-terminal glycine from covalently attached proteins. In plants, H2B is mono-ubiquitinated. UB26/SUP32 de-ubiquitinates H2B and de-ubiquitination of H2B is necessary for H3K9 dimethylation, which directs CpNpG and CpNpNp methylation. These results show that H2B de-ubiquitination by UB26 is required for heterochromatic H3 methylation and DNA methylation (Sridhar et al. 2007).

#### 1.7 Sumoylation

Sumoylation is a post-translational protein modification in which small ubiquitin-related modifier (SUMO) proteins are conjugated to

protein substrates in a process depending on SUMO E3-ligases, whereas desumoylation is the removal of SUMO proteins from their target proteins by SUMO proteases. Sumoylation protects target proteins against proteasomal degradation because it prevents ubiquitination (Ulrich 2005). In humans and yeast, sumoylation occurs on lysine residues of H2A (K136), H2B (K6/K7, K16/K17), H3 and H4 (all five Ks). Sumoylation of H4 appears to play an important role in transcriptional repression (Shiio and Eisenman 2003). In yeast, substitution mutation of sumoylation sites in histones increases transcription, whereas SUMO-histone fusion represses transcription. Sumoylation of histone blocks acetylation and ubiquitination. Transcriptional repression might be caused by prevention of lysine acetylation due to its sumoylation or recruitment of HDACs, which deacetylate neighboring acetyllysine (Nathan et al. 2006).

## 2 DNA Methylation

Cytosine methylation of DNA is a ubiquitous epigenetic mark well studied across various species. DNA methylation is the major mechanism of heritable epigenetic modification. Methylation occurs on the 5' position of cytosine in DNA. 5-methylcytosine accounts for as high as 30% of the total cytosine content in plants as compared to only 4% in mammals (Finnegan et al. 1998). In animals, the most common methylation is 5' cytosine methylation in CpG sites (Bird 2002). In plants, cytosine methylation of DNA occurs at symmetric CpG and CpNpG sites (where N is any nucleotide) and asymmetric CpHpH sites [where, H is Adenine (A), Cytosine (C), or Thymine (T)]. Asymmetric methylation is re-established in every generation, whereas symmetric methylation is transmitted through meiosis (Martienssen and Colot 2001). In both plants and animals, heterochromatin, repetitive sequences and transposons are rich in methylated cytosine. Methylation of transposons keeps them in an inactive state, and erasure of methylation results in activation of transposons. Similarly, methylation of genes results in gene silencing (Martienssen and Colot 2001; Bird 2002). Cytosine methyltransferases catalyze the transfer of an activated methyl group from S-adenosyl methionine to the 5' position of the cytosine ring. New cytosine methylation marks on DNA

are created by de novo DNA methyltransferases, whereas maintenance of DNA methyltransferase propagates the symmetric methylation marks on the parental DNA. After each round of DNA replication, the parental DNA contains the methylated cytosine, and the daughter strand lacks cytosine methylation. Hemi-methylated daughter DNA is fully methylated by a maintenance DNA methyltransferase, which provides a mechanism to maintain DNA methylation and heterochromatin after each round of DNA replication (Finnegan et al. 1998; Martienssen and Colot 2001; Bird 2002; Chan et al. 2005).

In mammalian cells, the methyltransferases DNMT3A and DNMT3B are involved in de novo methylation, whereas DNMT1 acts as the maintenance methyltransferase. The *Arabidopsis* genome encodes at least ten DNA methyltransferases, which can be grouped into three classes. The first class, MET family methyltransferase homologues to vertebrate DNMT1, serve as maintenance methyltransferases. Molecular genetic analysis revealed that MET1 is a major maintenance methyltransferase in *Arabidopsis*. Mutants of the *MET1* gene (*decreased DNA methylation-2* mutants) showed reduced methylation of repeat DNA sequences. Three *MET1*-related genes, *MET2a*, *MET2b*, and *MET3*, have been identified in *Arabidopsis*, but their role in DNA methylation is not known. *Arabidopsis* MET1 methylates cytosines in CpG sequences. The second class of *Arabidopsis* DNA methyltransferases are the chromomethylases (CMTs), which are unique to plants. CMTs preferentially methylate cytosines in CpNpG sequences and are involved in DNA methylation in heterochromatin. The third class of methyltransferases in *Arabidopsis* is the domains rearranged methylase class (DRM; the canonical methyltransferase motifs are organized in a novel order), which is mostly related to DNMT3. Loss-of-function mutations in de novo synthesis as well as maintenance of methyltransferases, resulted in release of transcriptional gene silencing and various developmental alterations (Martienssen and Colot 2001; Bird 2002; Chan et al. 2005).

Erasure of the DNA methylation pattern is a crucial process for the dynamic epigenome. Epigenetic marks in some of the loci need to be erased when the cell type changes from one tissue to another tissue. In contrast to the methylation mechanisms, the DNA demethylation mechanisms are less understood. The bifunctional



DNA glycosylase/lyase repressor of silencing-1 (ROS1) actively removes DNA methylation by a base-excision repair mechanism in *Arabidopsis*. The loss-of-function mutations of *ROS1* result in DNA hypermethylation and enhance transcriptional gene silencing (Gong et al. 2002). Transgenic plants over-expressing *ROS1* showed erasure of cytosine methylation in CpG, CpNpG and CpHpHp sequences, reduced level of DNA methylation and increased level of target gene expression (Agius et al. 2006). ROS1 plays a crucial role in pruning the DNA methylation pattern, and thus has a key role in the plasticity of the epigenome (Zhu et al. 2007c). Analysis of *Arabidopsis* mutants of demeter (DME), a protein similar to ROS1, revealed that DME is necessary for endosperm gene imprinting and seed viability in *Arabidopsis* (Choi et al. 2002). Genome-tiling microarray analysis of *ros1*, *dml2* (demeter-like-2) and *dml3* mutants and wild-type *Arabidopsis* revealed additional target genes of the demethylases (Penterman et al. 2007). Maintenance of DNA methylation at CG sequences is responsible for the formation of stable epialleles that are heritable across generations. In comparison, histone modifications and CpNpG and CpNpNp DNA methylation are involved in dynamic regulation of transcription in response to developmental and environmental cues and thus may carry epigenetic memory in the short and medium term within one generation (Vaillant and Paszkowski 2007).

## 2.1 Box Essay: Analysis of DNA Methylation

DNA methylation is a hallmark of epigenetic changes. DNA methylation (5-methylcytosine) can be detected and quantified by using one or more of the following methods. Histone modifications can be detected by using antibodies specific to different modified histones.

### 2.1.1 Methylation-Specific Restriction Analysis

Use of methylation-sensitive restriction enzymes is a classical method of DNA methylation analysis. Restriction enzymes which show DNA methylation sensitive restriction and have CG in their recognition sequences are employed in this

protocol. The restriction enzymes *HpaII* and *MspI* recognize the CCGG sequence. *HpaII* can not cut cytosine methylated DNA (C<sup>m</sup>CGG), while *MspI* can cut this sequence. These two enzymes can be used to distinguish methylated from unmethylated CCGG sequences. The enzymes have limited applications because not all CpG methylation sites are located within CCGG sequences. Further, non-CpG methylation including CpHpG and CpHpH methylation cannot be detected by these enzymes. After restriction digestion of genomic DNA, PCR-based methylation analysis of genomic DNA can be done. Another methylation specific restriction endonuclease *McrBC* recognizes Pu<sup>m</sup>C [N<sub>40-3000</sub>] Pu<sup>m</sup>C and cleaves only methylated DNA. The optimal distance between Pu<sup>m</sup>C pairs is 55–103 bp, with detectable cleavage observed at spacing of 32 bp to 2 kb (Stewart and Raleigh 1998).

### 2.1.2 Methylated DNA Immunoprecipitation (MeDIP)

Methylated DNA immunoprecipitation (MeDIP/mCHIP) can be done by using a monoclonal antibody that specifically recognizes 5-methylcytosine (Keshet et al. 2006). In this method, genomic DNA is randomly sheared (300–1,000 bp) by sonication and immunoprecipitated with a monoclonal antibody specific for 5-methylcytosine. Unbound DNA and enriched 5mC containing DNA fraction can be compared by PCR or microarray analysis. The depleted and methylated DNA enriched (MeDIP fraction) fractions are labeled and hybridized to whole-genome tiling microarrays (Zhang et al. 2006).

### 2.1.3 Bisulfite Method

Genomic DNA is isolated, sheared or digested into fragments with restriction enzymes and denatured to give a single stranded DNA fragment. Bisulfite treatment of DNA, at low pH (dilute sulfuric acid) and 55°C, converts cytosine residues to uracil (Frommer et al. 1992). Although 5-methylcytosine can be deaminated by bisulfite into thymine, the reaction rate for cytosine to uracil is very fast as compared with 5-methylcytosine to thymine. Thus, during bisulfite conversion, only cytosine is converted into uracil (Munson et al. 2007). After bisulfite treatment, cytosine residues

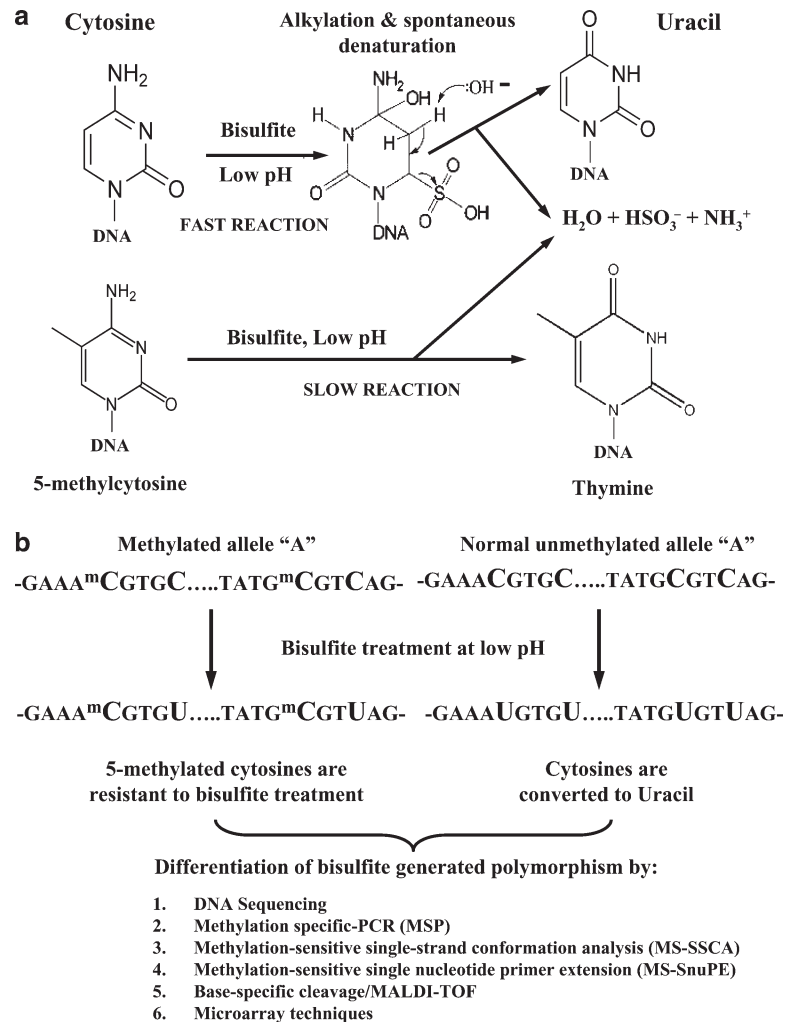

Fig. 1. Bisulfite method of DNA methylation analysis. (a) Bisulfite converts cytosine to uracil; (b) genomic DNA sequence depending upon methylation status gives rise to different sequences after bisulfite treatment.

will be converted into uracil and 5-methylcytosine will remain the same (Fig. 1). Bisulfite treatment converts unmethylated cytosine to uracil, which can no longer pair with the unmodified guanine in the opposite strands, so the two DNA strands are no longer complementary. The bisulfite treated DNA is neutralized, desalted, and dissolved in water or a buffer to detect bisulfite generated polymorphism by any of the following methods. After bisulfite treatment, methylated allele and its corresponding unmethylated allele will have different nucleotide sequence, which can be detected by direct DNA sequencing, pyrosequencing, methylation specific PCR (MSP), methylation sensitive-high resolution melting (MS-HRM),

methylation sensitive-single nucleotide primer extension (MS-SnuPE), base-specific cleavage reaction combined with MALDI-TOF mass spectrometry, methylation sensitive single-strand conformation analysis (MS-SSCA) and microarray. Details of these methods are presented in Text Box 11.1. Some of the limitations of bisulfite sequencing are incomplete conversion of unmethylated cytosines (resulting in false positives), degradation of DNA (at sites of protonated bases in DNA glycosyl bond to undergo hydrolysis that leads to chain breakage) and incomplete desulfonation of pyrimidine residues which might inhibit DNA polymerases in subsequent applications. Hence, adequate care must be taken during bisulfite

## Box 11.1 Sequencing Methods for Detecting Methylated Alleles

### *Direct DNA Sequencing*

Strand-specific and bisulfite-specific PCR primers flanking the methylation site are used to amplify bisulfite treated DNA strands. In PCR amplified DNA sequence, adenines will be complementary to the unmethylated cytosines (as there will be uracil after bisulfite conversion), while guanines will be complementary to the 5-methylcytosines. PCR product is cloned and sequenced by the dideoxy chain termination method (Sanger et al. 1977).

### *Pyrosequencing*

Pyrosequencing is also known as sequencing by synthesis. During DNA synthesis, DNA polymerase incorporates dNTPs into nucleic acid chain, releasing pyrophosphates (PPi). For each dNTP polymerized in a growing DNA chain, a PPi is released. The amount of dNTP incorporated is quantitatively proportional to the amount of PPi released by the polymerase. Pyrosequencing technique is based on the detection of released PPi, which is subsequently converted to ATP in the presence of adenosine phosphosulfate (APS) by ATP sulfurylase. This ATP powers the luciferase enzyme to oxidize luciferin to oxyluciferin with the emission of light ( $\lambda = 560$  nm) (Ronaghi et al. 1996, 1998). Single stranded short DNA fragments are taken in the reaction vessel (wells of microtiter plate). In pyrosequencing vessel, any one of the dTTP, dCTP, dGTP and  $\alpha$ -S-dATP (luciferase can use dATP but not  $\alpha$ -S-dATP) is added at a time. The commonly used pyrosequencing enzymes are the Klenow fragment of *Escherichia coli* DNA Pol I, ATP sulfurylase (*Saccharomyces cerevisiae*) and the luciferase (*Photinus pyralis*). The overall reaction takes place within 3–4 s at room temperature. One pmol of DNA synthesis yields  $6 \times 10^{11}$  ATP molecules which, in turn, is used by luciferase to generate  $>6 \times 10^9$  photons. The amount of photons emitted is detected by a photodiode/photomultiplier tube/charge-coupled device camera (CCD). Unincorporated dNTPs are degraded by a nucleotide degrading enzyme apyrase (isolated) from potato, before addition of the next nucleotide. Apyrase degrades dNTP into dNMP and 2 Pi (Ronaghi et al. 1996, 1998). Pyrogram intensity is kept at least at ten units for a peak corresponding to single nucleotide incorporation. Degree of methylation in DNA at each CpG methylation site can be determined from the ratio of T and C after pyrosequencing (Dupont et al. 2004; Tost and Gut 2007).

### *Methylation-Specific PCR (MSP)*

Bisulfite converted DNA can be used as template in PCR with methylation-specific primers (include sequences complementary to 5-methylcytosines) or unmethylation-specific primers (include sequences complementary to thymines converted from unmethylated cytosines). Depending upon the amplification by the methylation-specific or unmethylation-specific primers, the methylation status of CpG sequences is determined (Herman et al. 1996). As an increase in CpG in the primers increases the specificity of MSP, it is particularly useful to analyze specific alleles with high CpG methylation density. MSP can be combined with real-time quantitative PCR and melting curve analysis.

### *Methylation-Sensitive Single-Strand Conformation Analysis (MS-SSCA)*

Single-stranded DNA fragments of identical size but different sequences differentially migrate in non-denaturing gel electrophoresis. This principle is used in the single strand conformation polymorphism analysis (SSCA) for single-nucleotide polymorphism (SNP). This method can be employed to distinguish bisulfite-treated and PCR-amplified DNA sequences with the CpG methylation sites (Bianco et al. 1999).

**Box 11.1** (continued)*Methylation-Sensitive High Resolution Melting Analysis (MS-HRM)*

High resolution melting (HRM) analysis is a real-time PCR-based technique to distinguish SNPs. Since the bisulfite converted methylated DNA and unmethylated DNA differ in their sequences, PCR products from these DNA templates differ markedly in their melting profiles. An intercalating fluorescent dye is used to bind the double stranded DNA of PCR amplicons, and then the temperature of the reaction vessel is increased to melt the DNA. Change in fluorescence is monitored precisely as a DNA duplex melts. MS-HRM can be used for estimation of the methylation level by comparing the melting profiles of unknown PCR products to the melting profiles of PCR products derived from standards with a known unmethylated to methylated template ratio. This method quantifies methylation in the whole amplified region (Wojdacz and Dobrovic 2007).

*Methylation-Sensitive Single Nucleotide Primer Extension (MS-SnuPE)*

Single nucleotide primer extension (SnuPE) method designed originally to analyze single-nucleotide polymorphism can be used with bisulfite-converted DNA as template to detect DNA methylation. Genomic DNA is treated with bisulfite to convert unmethylated Cytosine to Uracil while leaving 5-methylcytosine unaltered. Bisulfite converted DNA is used as a template for strand-specific PCR and PCR amplicon from the region of interest is then subjected to methylation sensitive-SNuPE. PCR primers are designed to hybridize immediately upstream (5') of the cytosine being investigated for methylation. After the primer has annealed to its target sequence, a single nucleotide extension reaction is performed in the presence of a DNA polymerase and an appropriate <sup>32</sup>P-labeled dNTP, i.e., <sup>32</sup>P-dCTP (will be incorporated in methylated sites) or <sup>32</sup>P-dTTP (will be incorporated in unmethylated sites). Reaction products are subjected to electrophoresis on polyacrylamide gels for visualization and quantitation by phosphorimage analysis. The band signal intensity in the C lanes (<sup>32</sup>P-dCTP) represents the relative amount of 5-mCytosine present at each CpG site. The percentage of methylation at each monitored site is therefore equivalent to C/(C + T) (Gonzalzo and Liang 2007). In addition to the radioactive dNTP method, matrix assisted laser desorption ionization-time of flight (MALDI-TOF) mass spectrometry analysis or ion pair-reverse phase-high performance liquid chromatography (IP-RP-HPLC) can also be used to distinguish primer extension products.

*Base-Specific Cleavage Reaction Combined with MALDI-TOF Mass Spectrometry*

Bisulfite treated DNA is used as template to PCR amplify the region of interest by using primers located outside of the CpG islands. One primer is tagged with a T7 promoter sequence. The PCR product is used for in vitro transcription by using T7R and DNA polymerase. The resulting single stranded RNA is subsequently cleaved by base specific (3' to either rUTP or rCTP) endoribonuclease, RNase A. The cleavage products are analyzed by MALDI-TOF MS. A characteristic mass signal pattern is obtained depending on the cleavage scheme, as follows: (a) methylation can result in new cleavage sites and thus new, shorter products; (b) methylation can convert an existing cleavage site into a non-cleavable site and, thus results in a new, longer product; and (c) methylation can generate a sequence change in an existing cleavage product that does not affect cleavage but generates a mass shift (Ehrich et al. 2005; Coolen et al. 2007).

(continued)



**Box 11.1** (continued)*Microarray-Based Methods*

Several methods based on microarrays have been developed to study DNA methylation. In methylation-specific oligonucleotide (MSO) microarray, the bisulfite-modified DNA is used as template for PCR amplification resulting in conversion of unmethylated cytosine, but not methylated cytosine, into thymine within CpG islands of interest. PCR products from methylated and unmethylated alleles are fluorescently labeled separately and hybridized to an oligonucleotide (19–23 nucleotides in length) arrays designed using oligonucleotide pairs targeting CpG sites. The quantitative differences in hybridization are determined by fluorescence analysis (Gitan et al. 2002). As an alternative to bisulfite treatment, methylation sensitive restriction digestion of genomic DNA can be used to enrich methylated and unmethylated fractions. For enriching the unmethylated fraction, genomic DNA is cleaved by methylation sensitive restriction enzyme, followed by CpG specific adaptor ligation. These products are then cleaved by CpG specific cleavage by *McrBC*, which results in intact DNA borderd with adaptors in case no CpG is in that sequence or results in cleavage of DNA with CpG sequence. PCR amplification by using adaptor specific primers results in enrichment of unmethylated DNA fraction. To enrich methylated DNA fraction, genomic DNA is cleaved by *TasI* or *Csp6I*, followed by adaptor ligation. These products are cleaved with methylation sensitive restriction enzymes and then PCR-amplified by using adaptor specific primers. The enriched DNA (methylated and unmethylated) fractions are labeled with fluorescent dyes (Cy3 and Cy5) separately and hybridized to oligonucleotide microarrays (Schumacher et al. 2006). In another method, genomic DNA is sheared by nebulization and divided into equal parts. One part is then subjected to *McrBC* (prefers methylated DNA as substrate) digestion. *McrBC* treated and un-treated genomic DNA fractions are fractionated separately on gels and >1 kb fragments are recovered and labeled with fluorescent dyes (Cy5 for undigested and Cy3 for *McrBC* digested DNA). These samples are mixed equally and hybridized to tiling microarrays. A sequence that is methylated will give a Cy5/Cy3 ratio >1, as untreated DNA will retain all methylated DNA, while methylated DNA cleaved with *McrBC* will have less DNA (Lippman et al. 2005).

conversion and subsequent detection methods (Munson et al. 2007).

### 3 Interaction Between Histone Code and DNA Methylation

The combination of histone modification and DNA methylation patterns determines the expression state of chromatin. In plants, dimethylation of H3K4 combined with hypomethylation of DNA is associated with active transcription. Conversely, transcriptional repression occurs due to dimethylation of K9 and K27 of H3 accompanied by DNA hypermethylation. Histone modifications can affect DNA methylation and vice versa.

The Kryptonite mutant was identified as a suppressor of gene silencing at the superman (*SUP*) locus in *Arabidopsis*. Kryptonite encodes

a methyltransferase gene specific to methylation of histone H3K9. Loss-of-function kryptonite mutants resemble the chromomethylase3 (*cmt3*) mutant and show loss of cytosine methylation at CpNpG sites. CMT3 was found to interact with heterochromatin protein-1 (HP1), which in turn interacts with methylated histones. Thus, CpNpG DNA methylation is controlled by histone H3K9 methylation (Jackson et al. 2002).

Genetic screening for mutants, having decreased DNA methylation, led to the isolation of *ddm1* (decreased DNA methylation-1) in *Arabidopsis*. *DDM1* encodes a SNF2/SWI2-like ATP-dependent chromatin remodeling enzyme, which indirectly maintains DNA methylation in transposon and other sequences. Loss-of-function *ddm1* mutants of *Arabidopsis* exhibited loss of DNA methylation and a modification in

H3 methylation pattern. In *ddm1* mutants, H3K9 methylation is replaced by H3K4 methylation (Gendrel et al. 2002).

Histone ubiquitination and acetylation have also been found to influence DNA methylation. H2B deubiquitination by UBP26 is required for heterochromatic H3 methylation and DNA methylation (Sridhar et al. 2007). Analysis of *Arabidopsis* HDA6 mutant alleles *axe1* (auxin gene expression-1), *rts1* (RNA-mediated transcriptional silencing-1) and *sil1* (modifiers of silencing-1) showed that histone deacetylation is required for enhanced DNA methylation and transcriptional gene silencing (Murfett et al. 2001; Aufsatz et al. 2002; Probst et al. 2004). Besides the influence of histone modification on DNA methylation, one kind of histone modification can also affect the other kind of histone modification. Knockout mutants of *Arabidopsis* *HDA6* exhibited loss of promoter cytosine methylation, replacement of H3K9 dimethylation with H3K4 trimethylation, and increased H3K9 acetylation, H3K14 acetylation, and H4 tetra-acetylation. These changes resulted in derepression of silenced *rRNA* genes. Thus, erasure of histone acetylation by HDA6 regulates rRNA gene silencing through concerted histone and DNA modifications (Earley et al. 2006). Further, transgenic downregulation of maize *HDA101* (a RPD3-type *HDAC* gene) affects histone modifications, other than acetylation, including dimethylation of H3 at K4 and K9 and phosphorylation of H3 at Ser10 (Rossi et al. 2007). Histone modification-guided DNA methylation provides a mechanism for the epigenetic inheritance of histone code.

### 3.1 Small RNAs

Small non-coding RNAs of ~21 to 24 nt in length, namely microRNAs (miRNAs) and siRNAs, are ubiquitous repressors of gene expression in animals and plants. The biogenesis pathways of these two types of small RNAs are distinct. miRNAs, which are synthesized from single-stranded primary miRNA (pri-miRNA) transcripts, which further are transcribed from miRNA genes (*MIR* genes) by RNA polymerase II. The pri-miRNA transcript forms a secondary structure of an imperfectly paired hairpin, which is cleaved by a ribonuclease III-like enzyme called dicer-like-1 (DCL1) protein to produce an miRNA-miRNA\* duplex of ~21 nt in the nucleus. A nuclear dsRNA-binding protein, hyponastic Leaves-1 (HYL1), helps DCL1 recognize and accurately

cleave pri-miRNA. Hua enhancer-1 (HEN1), a nuclear methyltransferase, methylates the 2'-OH group of 3-terminal nucleotides in the miRNA-miRNA\* duplex, which is then exported from the nucleus into cytoplasm by hasty (HST), a member of the importin  $\beta$ /karyopherin nucleocytoplasmic transporters. In the cytosol, the miRNA-miRNA\* duplex is unwound into a single-stranded mature miRNA by an unknown helicase (Jones-Rhoades et al. 2006; Mallory and Vaucheret 2006).

siRNAs are synthesized from long double-stranded RNAs (dsRNAs) of endogenous or exogenous origin. The endogenous sources of dsRNAs are miRNA-directed cleavage products of non-coding single-stranded RNAs, mRNAs transcribed from natural *cis*-antisense (NAT) gene pairs, mRNAs of heterochromatin, DNA repeats and transposons. The exogenous sources of dsRNAs are transgenes and viral pathogen infection. dsRNA intermediates are generated during the replication of RNA viruses by viral RNA-dependent RNA polymerases (RDRs). Plant RDRs also generate dsRNAs from single-stranded RNAs. Biogenesis of different classes of siRNAs is carried out by specific combinations of RDR-DCL proteins. The siRNAs produced by miRNA-directed cleavage of mRNAs are called trans-acting siRNAs (ta-siRNAs). The synthesis of ta-siRNAs involves miRNA-directed cleavage of target mRNAs and recognition of cleaved single-stranded mRNA by suppressor of gene silencing3 (SGS3), a coiled-coil protein with a zinc finger domain and synthesis of complementary RNA strands by RDR6 (suppressor of gene silencing-2, silencing defective-1). Then the formed dsRNAs are cleaved by DCL4 to produce ta-siRNAs. The siRNAs synthesized from the mRNAs encoded by a NAT gene pair are called NAT-generated siRNAs (NAT-siRNAs). Genome analyses and expression profiling have revealed that thousands of NAT gene pairs generate complementary mRNAs, which may form dsRNAs. These dsRNAs are processed by DCL2, RDR6, SGS3, and a plant-specific RNA polymerase IV, NRPD1A (large subunit of Pol IVa), to generate a 24-nt nat-siRNA, which directs the biogenesis of 21-nt nat-siRNAs by DCL1. The third type of siRNAs is synthesized by NRPD1A, RDR2 and DCL3 by processing RNAs from transposons, 5S rRNA genes and DNA repeats (Xie et al. 2004; Borsani et al. 2005; Yoshikawa et al. 2005; Jones-Rhoades et al. 2006; Mallory and Vaucheret 2006; Ronemus et al. 2006).

Small RNAs cause posttranscriptional gene silencing by cleavage or translational repression of complementary target mRNAs or transcriptional gene silencing (TGS) (Bartel 2004; Bao et al. 2004; Chan et al. 2005). Single-stranded small RNAs are incorporated into RNA-induced silencing complex (RISC) or RNA interference (RNAi)-induced transcriptional silencing (RITS) complex. Both of these silencing complexes contain argonaute (AGO) family proteins with two conserved domains, namely the PAZ (an RNA-binding domain) and PIWI (similar to RNase H enzyme) domains (Bartel 2004; Jones-Rhoades et al. 2006; Mallory and Vaucheret 2006; Matzke et al. 2007). The siRNA-RITS mediates transcriptional silencing of the loci from which the siRNAs are derived. Transcriptional silencing is imposed by chromatin remodeling and DNA methylation (Chan et al. 2004; Lippman et al. 2004; Jones-Rhoades et al. 2006; Mallory and Vaucheret 2006). Although a miRNA has also been shown to cause DNA methylation (Bao et al. 2004), most miRNAs and trans-acting siRNAs do not appear to cause RNA-directed DNA methylation (RdDM) (Zhang et al. 2006).

The siRNA pathway of TGS through chromatin modification in *Arabidopsis* requires DCL3, ARGONAUTE-4 (AGO4), RDR2, and nuclear Pol IV. Plants encode two functionally diverse forms of Pol IV, namely Pol IVa and Pol IVb. The largest subunits of Pol IVa and Pol IVb are encoded by *NRPD1a* and *NRPD1b*, respectively, and the second-largest-subunit is encoded by *NRPD2a*. Loss-of-function mutants of *Arabidopsis Pol IV*, *RDR2*, *DCL3* or *AGO4*, cause decreased cytosine methylation and reduced siRNA accumulation (Xie et al. 2004; Herr et al. 2005; Kanno et al. 2005; Onodera et al. 2005). AGO proteins are a vital component of RdDM complexes. In addition, the chromatin remodeler DRD1 (defective in RNA-directed DNA methylation-1), and the de novo cytosine methyltransferase DRM2 are required for RdDM in *Arabidopsis*. Maintenance of the heterochromatic state appears to depend on locus-specific transcription by Pol IVa, followed by siRNA biogenesis and assembly of AGO4- and NRPD1b-containing silencing complexes (Pontes et al. 2006). The SWI/SNF-like chromatin remodelling protein DRD1 cooperates with Pol IVb to facilitate RdDM and silencing of homologous DNA (Huetzel et al. 2006). AGO6 is required for siRNA accumulation and DNA methylation in some loci as

well. A suppressor screen for the DNA demethylase *ros1* mutant led to the identification of a key role of AGO6 in RdDM in *Arabidopsis*. Suppression of the transcriptional silencing phenotype of the *ros1-1* mutant was stronger with *ago4-1* than with *ago6-1*. The CpNpG and asymmetric methylation levels were lower in the *ago6-1* and *ago4-1* mutants than in the wild type (Zheng et al. 2007).

### III Abiotic Stress-Induced Epigenetic Changes

Studies with flax (*Linum usitatissimum*) in the 1960s demonstrated that environmental factors such as nutrients can induce heritable changes in the plant genome, and these changes are stably inherited by the progeny for several generations. *Nicotiana rustica* also showed heritable variation in response to a single generation of growth under special nutrient conditions (Durrant 1962; Hill 1965). Research during the last 2 decades unraveled the epigenetic mechanisms such as histone codes, DNA methylation and small RNAs as regulators of phenotypes of organisms that are not caused by changes in the DNA sequence. The following section discusses emerging evidence of chromatin modeling/remodeling induced by environmental stresses and inheritance of stress-induced epigenetic memory through mitosis and meiosis and its role in abiotic stress tolerance.

#### A Abiotic Stress-Induced Changes in Histone Code

Histone variants play an important role in chromatin remodeling. Expression analysis of histone genes revealed that linker histone H1-3 variant was induced by water stress, whereas expression of H1-1, H1-2 and H4 was unaffected by water stress in *Arabidopsis*. Also, drought-inducible H1-1 of *Arabidopsis* showed sequence similarities to a drought-inducible linker histone, H1-D, of *Lycopersicon pennellii* (Ascenzi and Gantt 1997). However, transgenic analysis of H1-3 overexpression or antisense revealed no phenotypic differences under drought (Ascenzi and Gantt 1999). The tomato H1 variant H1-S was shown to be induced by drought through an ABA dependent pathway (Bray et al. 1999; Scippa et al. 2000). H1-S antisense tomato transgenic plants showed about 37% higher stomatal conductance, transpiration

and photosynthetic rate than the wild type, however relative water content (RWA) was similar in wild-type and transgenic plants. Thus, drought stress-induced H1-S appears to regulate stomatal conductance in tomato (Scippa et al. 2004).

The plant-stress hormone ABA plays a crucial role in seed development by inducing storage reserve accumulation, dormancy and desiccation tolerance. Phaseolin (*phas*) expression is induced during seed embryogenesis but is silent in vegetative tissues. The repressive chromatin structure of the *phas* promoter is related to the repressed state of *phas* in leaves. Induction of *phas* expression is correlated with disruption of chromatin structure during embryogenesis. The expression of *Phaseolus vulgaris* ABI3-like factor (*PvALF*), a putative seed-specific *phas* activator, and ABA are required for the remodeling of chromatin architecture over the TATA box region of the *phas* promoter (Li et al. 1999). *PvALF* potentiates chromatin by mediating acetylation of H3-K9 and H4-K12, whereas ABA induction of *phas* is associated with acetylation of H3-K14 and methylation of H3-K4 (Ng et al. 2006). Thus, chromatin remodeling in a euchromatin region by ABA could play a crucial role in gene expression. ABA induces the expression of many stress-responsive genes, so chromatin remodeling might be involved in the expression of some ABA-mediated stress-responsive genes.

*Arabidopsis* seed germination can be arrested or delayed after imbibition (within 48 h) by osmotic stress or exogenous ABA. This germination arrest is accompanied by induction and maintenance of *ABI3* and *ABI5* expression and increased osmotolerance. The *PIKLE* (*PKL*) gene in *Arabidopsis* encodes a putative SWI/SNF-class chromatin-remodeling factor of the CHD3 type (harboring a chromodomain, an SNF2-related helicase/ATPase domain, a DNA binding domain and a PHD zinc finger). In animals, *PKL*-related genes are involved in chromatin remodeling and transcriptional repression (Ogas et al. 1999). In *Arabidopsis*, *PKL* expression is induced by imbibition to repress the embryonic traits (Henderson et al. 2004; Li et al. 2005). Pickle (*pk1*) mutants showed expression of *LEC1* and *FUS3* upon seed imbibition, which is otherwise repressed at that time (Ogas et al. 1999). Further, *pk1* mutants exhibit hypersensitive germination responses to ABA and persistent

high expression of *ABI3* and *ABI5* on ABA stimulation. Chromatin immuno-precipitation (ChIP) studies comparing dimethylation levels of K9 or K27 of H3 between wild-type and *pk1* seeds treated or not with ABA revealed ABA-treated *pk1* mutant seeds with 2- to 2.5-fold lower H3-K9 and H3-K27 methylation levels at *ABI3* and *ABI5* promoters than wild-type plants. Hence, *PKL* appears to repress *ABI3* and *ABI5* expression through chromatin remodeling (Perruc et al. 2007).

In addition to histone methylation, histone acetylation plays a role in mediating ABA sensitivity during germination. An APETALA2/EREBP-type transcription factor, *AtERF7*, interacts with the *Arabidopsis* homolog of a human global corepressor of transcription, *AtSin3*, which in turn interacts with *HDA19*. *HDA19* and *AtSin3* enhance the transcriptional repression activity of *AtERF7*. *AtERF7* and *AtSin3* RNAi transgenic plants showed increased sensitivity to ABA during germination. Thus, an ERF transcriptional repressor might repress the transcription through modification of histone acetylation status (Song et al. 2005).

Abiotic stress-induced histone modification (H3K4 methylation and H3 acetylation) associated with expression of submergence-inducible *ADH1* and *PDC1* gene loci in rice were examined under submergence stress. The K4 residues of H3 on the coding region of both *ADH1* and *PDC1* changed from a dimethylated to a trimethylated state during the first phase, which was accompanied by transcriptional activation. Acetylation of H3 increased throughout the stress period. Treating rice seedlings with trichostatin A, an HDAC inhibitor, increased H3 acetylation, as well as transcription of *ADH1* and *PDC1*. However, these chromatin modifications were recovered to the basal level after aeration (Tsuji et al. 2006).

Reprogramming growth and development in response to abiotic stress is the key to survival and reproduction of plants. Adjustment of growth processes is one of the critical responses of plants to environmental stresses. The temporary growth arrest under abiotic stress is regulated by chromatin remodeling. In *Arabidopsis*, over-expression of the SNF2/brahma-type *AtCHR12* chromatin-remodeling gene led to growth arrest of primary buds and reduced growth of the primary stem under non-stress conditions. This effect was more



pronounced under drought and heat stresses. In contrast, the *AtCHR12*-knockout mutant showed less growth arrest than the wild type under moderate stress (Mlynárová et al. 2007).

A *RD29A::LUC* reporter-facilitated genetic screen identified the mutant *hos15-1* (for high expression of osmotically responsive genes), which shows super-induction of *RD29A::LUC* in response to exogenous ABA, cold and salt stresses. During germination, *hos15-1* mutants exhibit hypersensitivity to inhibition by ABA or NaCl, and mutant plants are more sensitive to freezing stress. In contrast to the super-induction of the stress-responsive gene *RD29A*, the expression of the key flowering-regulatory genes *SOC* and *FT* is downregulated in *hos15-1* mutants, which results in late flowering of *hos15-1*. *HOS15* encodes a protein similar to the human WD-40 repeat protein TBL1 (transducin beta-like protein-1). TBL1 interacts with histone and is a component of the chromatin repression complex involved in histone deacetylation. In *Arabidopsis*, *HOS15* interacts with histone H4. The level of acetylated histone H4 is higher in *hos15* mutants than in the wild type. Further, the *RD29A* promoter is associated with a substantially higher level of acetylated histone H4 in the *hos15* mutant than in wild type under cold stress conditions. Consistent with this, the induction of the *RD29A* gene is higher in the *hos15* mutant than in the wild type under cold stress. Thus, *HOS15* plays a crucial role in regulating stress tolerance and flowering through chromatin remodeling in *Arabidopsis* (Zhu et al. 2007b).

Mutations in the *Arabidopsis* RPD3/HDA1-type HDAC (HDA6), affect transgene expression, DNA methylation, as well as regulation of rRNA genes (Probst et al. 2004). In *Arabidopsis*, the silencing of promoters requires components of the RNAi machinery and promoter dsRNA to induce cytosine methylation and histone deacetylation catalysed by the RPD3-type histone deacetylase AtHDA6 (Aufsatz et al. 2002, 2007). The *AtRPD3A::β*-glucuronidase reporter gene was induced by wounding, *Alternaria brassicicola* pathogen infection, and the plant hormones jasmonic acid and ethylene. Transgenic plants over-expressing *AtRPD3A* (=HDA19) exhibited decreased histone acetylation levels, whereas *HDA19*-RNAi plants showed increased levels. Consistent with this, the expression of ethylene response factor-1 and pathogenesis-related

genes (basic chitinase and  $\beta$ -1,3-glucanase) was upregulated in *35S:HDA19* plants, but downregulated in *HDA19*-RNAi plants. These results showed that chromatin remodeling and gene expression in response to biotic stress and hormones is regulated through HDAs in *Arabidopsis* (Zhou et al. 2005).

Expression analysis of HDAC genes of rice showed that the level of several HDACs is influenced by plant hormones as well as abiotic stresses. The expression of *HDA705*, *HDT701*, and *HDT702* is affected by salicylic acid, jasmonic acid or ABA. *HDT701*, *HDT702*, *SRT701* and *SRT702* are repressed by ABA. *SRT701* and *SRT702* are repressed by ABA, cold, mannitol and salt stresses. In addition, cold stress decreased the expression of *HDA712*, whereas mannitol induced the expression of *HDT701* and high salt stress induced the expression of *HDT701* and *HDA714*. The stress-responsive expression pattern of these HDACs suggests that they may play a role in chromatin modeling in response to environmental stresses (Fu et al. 2007). ABA represses the expression of *AtHD2C*, and over-expression of *AtHD2C* resulted in lower transpiration and greater tolerance to salt and drought stresses than the wild type. The expression of ABA-responsive genes *RD29B* and *RAB18* was increased, whereas that of *ABI2*, *SKOR*, *KAT1* and *KAT2* was decreased in transgenic plants constitutively over-expressing *AtHD2C* (Sridha and Wu 2006). These results show that abiotic stress and hormone responses are modulated by acetylation and deacetylation of histones.

In yeast, Gcn5, a component of transcriptional adaptor complexes ADA and SAGA, regulates gene expression under normal and stress conditions. Yeast *ada2* and *gcn5* null mutants are sensitive to low- and high-temperature stresses (Marcus et al. 1994). Since the transcriptional activation activity of *AtCBF1* (C-repeat binding factor-1) expressed in yeast was greatly impaired in yeast mutants *ada2*, *ada3*, or *gcn5*, the role of their homologs in *Arabidopsis* was examined. AtADA2 and GCN5 were found to interact in vitro with CBF1, which suggests that CBF1 might induce transcription of cold-responsive genes through the recruitment of the ADA/SAGA-like complexes (Stockinger et al. 2001). Loss-of-function mutants of *Arabidopsis* *ADA2b* and *GCN5* exhibited pleiotropic effects on plant

growth and development and cold stress response. Interestingly, nonacclimated *ada2b-1* (but not *gcn5-1*) mutant plants were more freezing tolerant than nonacclimated wild-type plants. These results suggest that ADA2b might play a role in repressing the freezing tolerance mechanism (Vlachonasios et al. 2003). *Arabidopsis gcn5* mutants showed reduced light-inducible expression, whereas histone deacetylase *hd1/hda19* mutants showed an opposite effect. *gcn5* mutants showed reduced acetylation of histones H3 and H4, whereas *hd1* increased acetylation in promoter regions. Thus, light-regulated gene expression is mediated by *GCN5*, *TAF1* and *HD1* through acetylation of specific histone Lys residues (Benhamed et al. 2006).

### B Regulation of DNA Methylation by Abiotic Stresses

DNA methylation and demethylation play a key role in gene expression. Genome-wide high-resolution mapping of DNA methylation in *Arabidopsis* showed that peri-centromeric heterochromatin, repetitive sequences and regions producing siRNAs are heavily methylated. Approximately 33% of expressed genes contain methylation within transcribed regions, whereas only 5% of genes show methylation within promoter regions. Genes methylated in transcribed regions show a high level of constitutive expression, and promoter-methylated genes show tissue-specific expression (Zhang et al. 2006). Further studies in *Arabidopsis* revealed that short methylated genes are poorly expressed, but loss of methylation in the body of a gene leads to enhanced transcription (Zilberman et al. 2007). Mechanical stress to young internodes of *Bryonia dioica* induced ethylene accumulation and a rapid and transient decrease of cytosine methylation in DNA, as well as growth inhibition (Galaud et al. 1993). Growth inhibition caused by decreased DNA methylation under mechanical stress may be mediated by SNF2/Brahma-type AtCHR12 chromatin-remodeling protein as in drought and heat stress (Mlynárová et al. 2007).

To examine the effect of cold stress on the genome-wide methylation pattern, maize seedlings were subjected to cold stress for 6 days and recovered for a week. At the end of the recovery period, cold induced demethylation of a 1.8 kb

DNA fragment, designated *ZmMII*, was observed in root tissues. *ZmMII* contained a partial coding sequence of a putative protein and part of a retrotransposon. Maize seedlings grown at 23°C showed about 38% methylation of cytosine residues in *ZmMII*. Cold stress for 5 days reduced the methylation level to 24.7%, which further declined to 22.5% when cold-treated seedlings were returned to 23°C and grown for an additional 7 days. Expression analysis revealed that *ZmMII* was induced only under cold stress. Methylation mapping showed that cold stress induced demethylation in the DNA of the nucleosome core, but the linker region was unaltered. Interestingly, cold-induced hypomethylation was not reversed, even 7 days after bringing plants back to normal temperature (Steward et al. 2002). Heavy-metal ( $\text{Ni}^{2+}$ ,  $\text{Cd}^{2+}$  and  $\text{Cr}^{6+}$ ) stress induces specific DNA demethylation in roots of a metal-sensitive plant, *Trifolium repens* L., and a metal-tolerant plant, *Cannabis sativa* L (Aina et al. 2004). Stress-induced demethylation in root tissues cannot be inherited to the next generation but can be inherited through mitotic divisions, which might allow plants to survive during ensuing stress events.

Differential display of transcripts in wild-type and antisense *NtMET1* (type I DNA methyltransferase) tobacco plants led to identification of 31 genes, which are induced due to hypomethylation in *NtMET1* antisense plants (Wada et al. 2004). One of these genes was a glycerophosphodiesterase-like protein (*NtGPDL*), which is also responsive to aluminium stress. Bisulfite methylation mapping showed that the promoter region was unmethylated, but the coding sequence is methylated at CG sites under non-stress conditions. Aluminium, salt and cold stresses induced demethylation of the coding sequence within 1 h, followed by upregulation of *NtGPDL* in leaves. These treatments appear to induce oxidative stress, which might cause demethylation, because paraquat treatment efficiently induced the same demethylation at coding regions. Abiotic stress-induced cytosine demethylation might result in chromatin remodeling and thus enhance transcription (Choi and Sano 2007). In contrast to the demethylation induced by cold and heavy metal stresses, in tobacco cell-suspension culture, osmotic and salt stresses induced DNA hypermethylation in two heterochromatic loci, which was reversible when cells were returned to

non-stress media (Kovarik et al. 1997). Water-deficit stress also induced specific cytosine hypermethylation (CCGG) in the pea genome (Labra et al. 2002).

DNA methylation is also induced by interplant competition in the field. High-planting-density stress-induced DNA methylation is greater in a high density-sensitive genotype as compared with a high density-tolerant maize genotype (Tani et al. 2005). In high density-tolerant maize hybrids, the proportion of allelic additively expressed genes is higher than in high density-sensitive hybrids. A high proportion of additively expressed genes is positively associated with hybrid yield and heterosis (Guo et al. 2006).

### C siRNAs in Abiotic Stresses

Several endogenous siRNAs identified from stress-treated *Arabidopsis* plants include P78-C02, complementary to At2g27152 (AAO3, a drought stress-inducible ABA biosynthesis enzyme); P52-B05, complementary to a putative lipoxygenase; and P96-F02, complementary to the overlapping region between the 3' end of the *cis*-NAT gene pair *P5CDH* (pyrroline-5-carboxylate dehydrogenase) and *SRO5* (similar to *radicle induced cell death-1*) (Sunkar and Zhu 2004). In the *P5CDH* and *SRO5 cis*-NAT gene pair, *P5CDH* is constitutively expressed, whereas *SRO5* is induced by NaCl. Thus, exposure to salt stress results in complementary pairing of *P5CDH* and *SRO5* mRNAs in their 3' end. This double-stranded RNA is processed by a siRNA biogenesis pathway mediated by DCL2, RDR6, SGS3, and NRPD1A to produce a 24-nt *SRO5-P5CDH* nat-siRNA. The 24-nt nat-siRNA guides the cleavage of the *P5CDH* transcript to further produce a 21-nt *P5CDH* nat-siRNA by DCL1. These nat-siRNAs all guide cleavage of *P5CDH* mRNAs, leading to decreased proline degradation and proline accumulation. The *SRO5* protein mediates ROS detoxification under salt stress (Borsani et al. 2005). Many of the approximately 2,000 genes in convergent overlapping pairs in *Arabidopsis* are regulated by various environmental or hormonal stimuli (Girke and Zhu, unpublished data). These genes may also be regulated by nat-siRNAs, similar to the *P5CDH-SRO5* gene pair. However, whether stress-inducible siRNAs have any role in RdDM is not known.

Retrotransposons are a major constituent of the plant genome. These transposons are normally silent but are activated by biotic and abiotic stresses. *Tnt1* retrotransposons are activated in response to various stresses in tobacco and tomato (Grandbastien et al. 2005). One of the members of the long terminal repeat (LTR) retrotransposon family, *TLC1*, is activated and expressed under high salt stress and wounding. As well as stresses, the plant hormones ethylene, methyl jasmonate, salicylic acid and 2,4-dichlorophenoxyacetic acid also induce expression of the *TLC1* family in vivo (Tapia et al. 2005). Cold stress activates transposons through epigenetic changes. In *Antirrhinum majus*, the transposition of *Tam3* is strongly suppressed during growth at 25°C because of the hypermethylated state. Methylcytosine impairs the binding ability of the *Tam3* transposase (TPase). Cold stress (15°C) induces hypomethylation of the *Tam-3* transposon. Growth at low temperatures promotes TPase binding to *Tam3*. TPase also binds to *Tam3* immediately after DNA replication. Binding of TPase to *Tam3* decreases *Tam3*-DNA methylation, which permits low temperature-dependent transposition (Hashida et al. 2006). A change in the epigenetic state of transposons induced by abiotic stresses might provide promoter/enhancer activities for adjacent genes (Kashkush et al. 2002).

### D Transgeneration Stress Memory

Mitotic and meiotic inheritance of the epigenetic marks induced by abiotic stresses has not been studied well. Abiotic and biotic stresses induce changes in the genome (Ries et al. 2000; Lucht et al. 2002; Kovalchuk et al. 2003; Arnholdt-Schmitt 2004; Cullis 2005). To study the inheritance of stress-induced changes in the genome, the progenies of *Arabidopsis* plants treated with UV-C radiation or flagellin (an elicitor of plant defense) were examined. These stress treatments are known to cause a high frequency of somatic homologous recombination. The untreated progenies of stress-treated parents exhibited a hyper-recombination state. This trait is dominant and transmitted through both the maternal and the paternal crossing partner (Molinier et al. 2006). The molecular basis of stress memory was examined in tobacco. Infection of tobacco by the tobacco mosaic virus (TMV) resulted in the

production of a signal that led to systemic changes in the frequency of the somatic and meiotic recombination rates. The progeny of infected plants showed hypomethylation in several leucine-rich repeat (LRR)-containing loci, hypermethylation in actin loci and no change in methylation in the loci of repetitive elements or 5.8S rRNA. The frequency of recombination is expected to be low in hypermethylated loci and high in hypomethylated loci. Consistent with the methylation pattern, the progeny of infected plants showed a higher frequency of rearrangements in loci carrying the homology to the LRR region of the gene resistant to TMV (*N*-gene), but the stability of repetitive-element loci and 5.8S ribosomal RNA loci was not affected. This evidence shows that stress-induced epigenetic changes in the genome can be stably inherited (Boyko et al. 2007).

The adaptive value of induced genome change was examined in rice. Rice progeny obtained from 5-aza-deoxycytidine (inhibitor of cytosine methylation)-treated seeds (after ten generations) were screened to identify genomic regions with changed methylation status by the methylation-sensitive amplified polymorphism (MSAP) and bisulfite mapping methods. In one of the hypomethylation lines (line-2), methylation was completely erased in a Xa21-like protein gene, *Xa21G*. In wild-type plants, the *Xa21G* promoter was methylated, and the gene had no detectable expression. In line-2, *Xa21G* was expressed constitutively and conferred resistance to *Xanthomonas oryzae* pv. *oryzae*, race PR2 (Akimoto et al. 2007). This study showed that changes in DNA methylation can be stably inherited and some of which might enhance the fitness of plants to adverse environmental conditions.

In contrast to the transgeneration epigenetic memory, a well-studied cold-induced epigenetic memory, “vernalization,” is erased during seed formation in each generation. Vernalization is the acquisition of the competence to flower by prior exposure of the apical meristem of plants to low temperatures in winter. Winter-habit plants (e.g., winter wheat, barley, oat, rye and oilseed rape) have a vernalization requirement, which prevents premature transition to the reproductive phase before the threat of freezing stress during winter has passed. Thus, the vernalization requirement allows plants to overwinter as seedlings and ensures that reproductive development and seed

production occurs under the optimal environmental conditions. Once the vernalization signal is perceived by the apical meristem, the message is persistent for a long time (often months) before the transition of the meristem from vegetative to floral growth. Cold stress acclimation occurs faster than vernalization in winter plants. Vernalization down-regulates the expression of flowering locus C (*FLC*), a MADS-box protein that maintains the vegetative state of the growing apex of plants, and subsequently, *FLC* is maintained in a repressed state in aerial tissues through epigenetic mechanisms (Parcy 2005; Sung and Amasino 2005). Transcriptome analysis revealed that cold stress upregulates the expression of genes involved in epigenetic regulation, examples of which are *NRPD1a*, DNA binding bromodomain-containing protein, the GCN5-related *N*-acetyltransferase (*GNAT*) family histone acetyltransferase 5 (*HAC5*), and histone deacetylase (Lee et al. 2005). Whether these proteins induce epigenetic changes in cold stress-responsive genes is not known. Many perennial trees, that do not require vernalization, time their flowering to avoid unfavorable environmental conditions. Whether these plants remember environment cues through epigenetic mechanisms is not known.

#### IV Conclusions and Perspectives

Epigenetic mechanisms namely histone amino-tail modifications and cytosine DNA methylation play a pivotal role in genomic imprinting, paramutation, genome defense and regulation of gene expression. The N-termini of nucleosomal core-histones undergo posttranslational modifications such as acetylation, methylation, glycosylation, phosphorylation, ADP-ribosylation, carbonylation, sumoylation and ubiquitination, and specific combinations of these modifications can be considered a “histone code”. Histone code determines the chromatin structure and thus regulates transcription. In plants, cytosine methylation of DNA occurs at symmetric CpG and CpNpG sites as well as asymmetric CpHpH sites. Asymmetric cytosine methylation has to be re-established in every cell generation, whereas symmetric cytosine methylation can be maintained and may be transmitted through meiosis. Small RNAs cause post-transcriptional gene silencing by guiding the cleavage or translational



repression of complementary target mRNAs or transcriptional gene silencing (TGS).

Plant hormones and abiotic stresses have been found to induce histone modification and chromatin remodeling, leading to altered gene expression. ABA induces chromatin remodeling to induce genes involved in storage protein accumulation in *Phaseolus vulgaris*. Submergence stress-induced histone H3 trimethylation and acetylation in the alcohol dehydrogenase (*ADH1*) and pyruvate decarboxylase (*PDC1*) loci are correlated with transcriptional activation in rice. Further, the SNF2/Brahma-type chromatin-remodeling protein CHR12 appears to play a key role in temporary growth arrest of *Arabidopsis* under abiotic stress. Abiotic stresses and plant hormones also induce the expression of histone deacetylases which lead to deacetylation of histones in some genetic loci and thus, repression of these loci might be important in abiotic stress tolerance of plants. Constitutive overexpression of *AtHD2C* resulted in lower transpiration and greater tolerance to salt and drought stresses than the wild type. Further, HOS15, a chromatin repression complex protein involved in histone deacetylation in *Arabidopsis* is crucial for freezing stress tolerance, as *hos15* mutant plants exhibit hypersensitivity to freezing.

Abiotic stresses also induce DNA methylation and demethylation to regulate gene expression. Mechanical stress to young internodes of *Bryonia dioica* induced ethylene accumulation and a rapid and transient decrease of cytosine methylation in DNA, as well as growth inhibition. Abiotic stresses such as cold, salt and heavy metal induce hypomethylation of specific genomic loci, often accompanied by an increase in gene expression of the hypomethylated loci. Further, hypomethylation of DNA induced by high salt, cold and plant hormones (ethylene, methyl jasmonate and salicylic acid) enhances transposition of transposons, which might provide promoter/enhancer activities for adjacent genes. In contrast to the demethylation, abiotic stresses also induce specific cytosine hypermethylation in plant.

UV-C and biotic stresses induce a high frequency of somatic homologous recombination in *Arabidopsis* and tobacco. This trait is meiotically transmitted across generation. Transgenerational stress memory appears to be mediated by epigenetic hypomethylation of the genome. Abiotic stresses often occur in cycles during a plant grow-

ing season. Stress memory transmitted mitotically through the epigenetic process might help plants effectively combat subsequent incidences of stress. Since somatic tissues can give rise to reproductive cells in plants, genomic changes induced in the vegetative cells may be transmitted to progeny. Stress-induced changes in the epigenetic state may be inherited across generations to confer an adaptive advantage. Often farmers use seeds harvested during the previous year to raise their new crop. Trans-generational stress memory might be advantageous or disadvantageous depending upon the environment. One of the impacts of stress on crops is growth and yield reduction. Stress memory might help the plant to better adapt to stress in the ensuing season. However, even if the crop is not encountering stress in the ensuing season, it may yield less due to the stress memory. Stress memory also has implications for breeding for stress environments and *in situ* conservation of plant species. Abiotic stress-induced histone and DNA modifications have been observed in several cases, but their inheritance (mitotic and meiotic) and trans-generational impacts need further studies. Comparative studies on abiotic stress responsive epigenomes and transcriptomes will enhance our understanding of abiotic stress responses of plants.

## Acknowledgements

The work in J.-K.Z's. lab was supported by National Institute of Health grants R01GM070795 and R01GM059138.

## References

- Agalioti T, Chen G, Thanos D (2002) Deciphering the transcriptional histone acetylation code for a human gene. *Cell* 111:381–392
- Agius F, Kapoor A, Zhu JK (2006) Role of the *Arabidopsis* DNA glycosylase/lyase ROS1 in active DNA demethylation. *Proc Natl Acad Sci USA* 103:11796–11801
- Aina R, Sgorbati S, Santagostino A, Labra M, Ghiani A, Citterio S (2004) Specific hypomethylation of DNA is induced by heavy metals in white clover and industrial hemp. *Physiol Plant* 121:472–480
- Akimoto K, Katakami H, Kim HJ, Ogawa E, Sano CM, Wada Y, Sano H (2007) Epigenetic inheritance in rice plants. *Ann Bot (Lond)* 100:205–217

- Alleman M, Sidorenko L, McGinnis K, Seshadri V, Dorweiler JE, White J, Sikkink K, Chandler VL (2006) An RNA-dependent RNA polymerase is required for par- amutation in maize. *Nature* 442:295–298
- Arnholdt-Schmitt B (2004) Stress-induced cell reprogram- ing: A role for global genome regulation? *Plant Physiol* 136:2579–2586
- Ascenzi R, Gantt JS (1997) A drought-stress-inducible his- tone gene in *Arabidopsis thaliana* is a member of a dis- tinct class of plant linker histone variants. *Plant Mol Biol* 34:629–641
- Ascenzi R, Gantt JS (1999) Molecular genetic analysis of the drought-inducible linker histone variant in *Arabidop- sis thaliana*. *Plant Mol Biol* 41:159–169
- Aufsatz W, Mette MF, Van Der Winden J, Matzke M, Matzke AJ (2002) HDA6, a putative histone deacetylase needed to enhance DNA methylation induced by double-stranded RNA. *EMBO J* 21:6832–6841
- Aufsatz W, Stoiber T, Rakic B, Naumann K (2007) *Arabi- dopsis* histone deacetylase 6: a green link to RNA silenc- ing. *Oncogene* 26:5477–5488
- Bao N, Lye KW, Barton MK (2004) MicroRNA binding sites in *Arabidopsis* class III HD-ZIP mRNAs are required for methylation of the template chromosome. *Dev Cell* 7:653–662
- Bartel DP (2004) MicroRNAs: genomics, biogenesis, mech- anism and function. *Cell* 116:281–297
- Benhamed M, Bertrand C, Servet C, Zhou DX (2006) *Ara- bidopsis* GCN5, HD1 and TAF1/HAF2 interact to regu- late histone acetylation required for light-responsive gene expression. *Plant Cell* 18:2893–2903
- Bianco T, Hussey D, Dobrovic A (1999) Methylation-sensitive, single-strand conformation analysis (MS-SSCA): a rapid method to screen for and analyze methylation. *Hum Mutat* 4:289–293
- Bird A (2002) DNA methylation patterns and epigenetic memory. *Genes Dev* 16:6–21
- Bird A (2007) Perceptions of epigenetics. *Nature* 447:396–398
- Bohnert HJ, Gong Q, Li P, Ma S (2006) Unraveling abiotic stress tolerance mechanisms – getting genomics going. *Curr Opin Plant Biol* 9:180–188
- Borsani O, Zhu J, Verslues PE, Sunkar R, Zhu JK (2005) Endogenous siRNAs derived from a pair of natural *cis*- antisense transcripts regulate salt tolerance in *Arabidop- sis*. *Cell* 123:1279–1291
- Boyko A, Kathiria P, Zemp FJ, Yao Y, Pogribny I, Kovalchuk I (2007) Transgenerational changes in the genome stability and methylation in pathogen-infected plants: virus-induced plant genome instability. *Nucleic Acids Res* 35:1714–1725
- Bray EA, Shih T-Y, Moses MS, Cohen A, Imai R, Plant AL (1999) Water-deficit induction of a tomato H1 histone requires abscisic acid. *Plant Growth Regul* 29:35–46
- Brownell JE, Zhou J, Ranalli T, Kobayashi R, Edmond- son DG, Roth SY, Allis CD (1996) *Tetrahymena* histone acetyltransferase A: a homolog to yeast Gcn5p linking histone acetylation to gene activation. *Cell* 84:843–851
- Camporeale G, Oommen AM, Griffin JB, Sarath G, Zempleni J (2007) K12-biotinylated histone H4 marks heterochro- matin in human lymphoblastoma cells. *J Nutr Biochem* doi:10.1016/j.jnutbio.2006.12.014
- Chan SW, Zilberman D, Xie Z, Johansen LK, Carrington JC, Jacobsen SE (2004) RNA silencing genes control de novo DNA methylation. *Science* 303:1336
- Chan SW, Henderson I, Jacobsen SE (2005) Gardening the genome: DNA methylation in *Arabidopsis thaliana*. *Nat Rev Genet* 6:351–360
- Chinnusamy V, Schumaker K, Zhu JK (2004) Molecular genetic perspectives on cross-talk and specificity in abi- otic stress signalling in plants. *J Exp Bot* 55:225–236
- Chinnusamy V, Zhu J, Zhu JK (2007) Cold stress regulation of gene expression in plants. *Trends Plant Sci* 12:444–451
- Choi CS, Sano H (2007) Abiotic-stress induces demethyla- tion and transcriptional activation of a gene encoding a glycerophosphodiesterase-like protein in tobacco plants. *Mol Gen Genom* 277:589–600
- Choi Y, Gehring M, Johnson L, Hannon M, Harada JJ, Gold- berg RB, Jacobsen SE, Fischer RL (2002) Demeter, a DNA glycosylase domain protein, is required for endosperm gene imprinting and seed viability in *Arabidopsis*. *Cell* 110:33–42
- Chow J, Yen Z, Ziesche S, Brown C (2005) Silencing of the mammalian X chromosome. *Annu Rev Genomics Hum Genet* 6:69–92
- Coolen MW, Statham AL, Gardiner-Garden M, Clark SJ (2007) Genomic profiling of CpG methylation and allelic specificity using quantitative high-throughput mass spec- trometry: critical evaluation and improvements. *Nucleic Acids Res* 35(18):e119
- Cullis CA (2005) Mechanisms and control of rapid genomic changes in flax. *Ann Bot (Lond)* 95:201–206
- Dupont JM, Tost J, Jammes H, Gut IG (2004) de novo quan- titative bisulfite sequencing using the pyrosequencing technology. *Anal Biochem* 333:119–127
- Durrant A (1962) The environmental induction of heritable change in *Linum*. *Heredity* 17:27–61
- Earley K, Lawrence RJ, Pontes O, Reuther R, Enciso AJ, Silva M, Neves N, Gross M, Viegas WJ, Pikaard CS (2006) Erasure of histone acetylation by *Arabidopsis* HDA6 mediates large-scale gene silencing in nucleolar domi- nance. *Genes Dev* 20:1283–1293
- Ehrich M, Nelson MR, Stanssens P, Zabeau M, Liloglou T, Xinarianos G, Cantor CR, Field JK, van den Boom D (2005) Quantitative high-throughput analysis of DNA methylation patterns by base-specific cleavage and mass spectrometry. *Proc Natl Acad Sci USA* 102:15785–15790
- Feil R, Berger F (2007) Convergent evolution of genomic imprinting in plants and mammals. *Trends Genet* 23:192–199
- Finnegan EJ, Genger RK, Peacock WJ, Dennis ES (1998) DNA methylation in plants. *Annu Rev Plant Physiol Plant Mol Biol* 49:223–247
- Fischle W, Wang Y, Allis LD (2003) Binary switches and modification cassettes in histone biology and beyond. *Nature* 425:475–479

- Frommer M, McDonald LE, Millar DS, Collis CM, Watt F, Grigg GW, Molloy PL, Paul CL (1992) A genomic sequencing protocol that yields a positive display of 5-methylcytosine residues in individual DNA strands. *Proc Natl Acad Sci USA* 89:1827–1831
- Fu W, Wu K, Duan J (2007) Sequence and expression analysis of histone deacetylases in rice. *Biochem Biophys Res Commun* 356:843–850
- Fuchs J, Demidov D, Houben A, Schubert I (2006) Chromosomal histone modification patterns – from conservation to diversity. *Trends Plant Sci* 11:199–208
- Galaud JP, Gaspar T, Boyer N (1993) Inhibition of internode growth due to mechanical stress in *Bryonia dioica*: relationship between changes in DNA methylation and ethylene metabolism. *Physiol Plantarum* 87:25–30
- Gendrel AV, Lippman Z, Yordan C, Colot V, Martienssen RA (2002) Dependence of heterochromatic histone H3 methylation patterns on the *Arabidopsis* gene *DDMI*. *Science* 297:1871–1873
- Gitan RS, Shi H, Chen CM, Yan PS, Huang TH (2002) Methylation-specific oligonucleotide microarray: a new potential for high-throughput methylation analysis. *Genome Res* 12:158–164
- Gong Z, Morales-Ruiz T, Ariza RR, Roldan-Arjona T, David L, Zhu JK (2002) *ROS1*, a repressor of transcriptional gene silencing in *Arabidopsis*, encodes a DNA glycosylase/lyase. *Cell* 111:803–814
- Gonzalogo ML, Liang G (2007) Methylation-sensitive single-nucleotide primer extension (Ms-SNuPE) for quantitative measurement of DNA methylation. *Nat Protoc* 2:1931–1936
- Grandbastien MA, Audeon C, Bonnivard E, Casacuberta JM, Chalhouh B, Costa APP, Le QH, Melayah D, Petit M, Poncet C, Tam SM, Van Sluys MA, Mhiri C (2005) Stress activation and genomic impact of *Tnt1* retrotransposons in Solanaceae. *Cytogenetic Genome Res* 110:229–241
- Grant PA (2001) A tale of histone modifications. *Genome Biol* 2: reviews 0003.1–0003.6
- Guo M, Rupe MA, Yang X, Crasta O, Zinselmeier C, Smith OS, Bowen B (2006) Genome-wide transcript analysis of maize hybrids: allelic additive gene expression and yield heterosis. *Theor Appl Genet* 113:831–845
- Hashida SN, Uchiyama T, Martin C, Kishima Y, Sano Y, Mikami T (2006) The temperature-dependent change in methylation of the *Antiirhinum* transposon *Tam3* is controlled by the activity of its transposase. *Plant Cell* 18:104–118
- Hassa PO, Haenni SS, Elser M, Hottiger MO (2006) Nuclear ADP-ribosylation reactions in mammalian cells: where are we today and where are we going? *Microbiol Mol Biol Rev* 70:789–829
- Henderson JT, Li HC, Rider SD, Mordhorst AP, Romero-Severson J, Cheng JC, Robey J, Sung ZR, de Vries SC, Ogas J (2004) *PICKLE* acts throughout the plant to repress expression of embryonic traits and may play a role in gibberellin dependent responses. *Plant Physiol* 134:995–1005
- Herman JG, Graff JR, Myöhänen S, Nelkin BD, Baylin SB (1996) Methylation-specific PCR: a novel PCR assay for methylation status of CpG islands. *Proc Natl Acad Sci USA* 93:9821–9826
- Herr AJ, Jensen MB, Dalmay T, Baulcombe DC (2005) RNA polymerase IV directs silencing of endogenous DNA. *Science* 308:118–120
- Hill J (1965) Environmental induction of heritable changes in *Nicotiana rustica*. *Nature* 207:732–734
- Holliday R (1994) Epigenetics: an overview. *Dev Genet* 15:453–457
- Houben A, Demidov D, Caperta AD, Karimi R, Agueci F, Vlasenko L (2007) Phosphorylation of histone H3 in plants – a dynamic affair. *Biochim Biophys Acta* 1769:308–315
- Huetzel B, Kanno T, Daxinger L, Aufsatz W, Matzke AJM, Matzke M (2006) Endogenous targets of RNA-directed DNA methylation and Pol IV in *Arabidopsis*. *EMBO J* 25:2828–2836
- Jackson JP, Lindroth AM, Cao X, Jacobsen SE (2002) Control of CpNpG DNA methylation by the kryptonite histone H3 methyltransferase. *Nature* 416:556–560
- Jenuwein T, Allis CD (2001) Translating the histone code. *Science* 293:1074–1080
- Jones-Rhoades MW, Bartel DP, Bartel B (2006) MicroRNAs and their regulatory roles in plants. *Annu Rev Plant Biol* 57:19–53
- Kanno T, Huetzel B, Mette MF, Aufsatz W, Jaligot E, Daxinger L, Kreil DP, Matzke M, Matzke AJ (2005) Atypical RNA polymerase subunits required for RNA-directed DNA methylation. *Nat Genet* 37:761–765
- Kashkush K, Feldman M, Levy AA (2002) Transcriptional activation of retrotransposons alters the expression of adjacent genes in wheat. *Nat Genet* 33:102–106
- Keshet I, Schlesinger Y, Farkash S, Rand E, Hecht M, Segal E, Pikarski E, Young RA, Niveleau A, Cedar H, Simon I (2006) Evidence for an instructive mechanism of de novo methylation in cancer cells. *Nat Genet* 38:149–153
- Khorasanizadeh S (2004) The nucleosome: from genomic organization to genomic regulation. *Cell* 116:259–272
- Kothapalli N, Camporeale G, Kueh A, Chew YC, Oommen AM, Griffin JB, Zemleni J (2005) Biological functions of biotinylated histones. *J Nutr Biochem* 16:446–448
- Kovalchuk I, Kovalchuk O, Kalck V, Boyko V, Filkowski J, Heinlein M, Hohn B (2003) Pathogen-induced systemic plant signal triggers DNA rearrangements. *Nature* 423:760–762
- Kovarik A, Koukalová B, Bezdek M, Opatrn Z (1997) Hypermethylation of tobacco heterochromatic loci in response to osmotic stress. *Theor Appl Genet* 95:301–306
- Labra M, Ghiani A, Citterio S, Sgorbati S, Sala F, Vannini C, Ruffini-Castiglione M, Bracale M (2002) Analysis of cytosine methylation pattern in response to water deficit in pea root tips. *Plant Biol (Stuttg)* 4:694–699
- Lachner M, O’Sullivan RJ, Jenuwein T (2003) An epigenetic road map for histone lysine methylation. *J Cell Sci* 116:2117–2124

- Lee BH, Henderson DA, Zhu JK (2005) The *Arabidopsis* cold-responsive transcriptome and its regulation by ICE1. *Plant Cell* 17:3155–3175
- Li GF, Bishop KJ, Chandrasekharan MB, Hall TC (1999)  $\beta$ -Phaseolin gene activation is a two-step process: PvALF-facilitated chromatin modification followed by abscisic acid-mediated gene activation. *Proc Natl Acad Sci USA* 96:7104–7109
- Li HC, Chuang K, Henderson JT, Rider SD Jr, Bai Y, Zhang H, Fountain M, Gerber J, Ogas J (2005) PICKLE acts during germination to repress expression of embryonic traits. *Plant J* 44:1010–1022
- Lippman Z, Gendrel AV, Black M, Vaughn MW, Dedhia N, McCombie WR, Lavine K, Mittal V, May B, Kasschau KD, Carrington JC, Doerge RW, Colot V, Martienssen R (2004) Role of transposable elements in heterochromatin and epigenetic control. *Nature* 430:471–476
- Lippman Z, Gendrel AV, Colot V, Martienssen R (2005) Profiling DNA methylation patterns using genomic tiling microarrays. *Nat Methods* 2:219–224
- Lucht JM, Mauch-Mani B, Steiner HY, Metraux JP, Ryals J, Hohn B (2002) Pathogen stress increases somatic recombination frequency in *Arabidopsis*. *Nat Genet* 30:311–314
- Mallory AC, Vaucheret H (2006) Functions of microRNAs and related small RNAs in plants. *Nat Genet* 38:S31–S36
- Marcus GA, Silverman N, Berger SL, Horiuchi J, Guarente L (1994) Functional similarity and physical association between GCN5 and ADA2: Putative transcriptional adaptors. *EMBO J* 13:4807–4815
- Martienssen RA, Colot V (2001) DNA methylation and epigenetic inheritance in plants and filamentous fungi. *Science* 293:1070–1074
- Matzke M, Kanno T, Huettel B, Daxinger L, Matzke AJM (2007) Targets of RNA-directed DNA methylation. *Curr Opin Plant Biol* 10:1–8
- Mlynárová L, Nap JP, Bisseling T (2007) The SWI/SNF chromatin-remodeling gene *AtCHR12* mediates temporary growth arrest in *Arabidopsis thaliana* upon perceiving environmental stress. *Plant J* 51:874–885
- Molinier J, Ries G, Zipfel C, Hohn B (2006) Transgenerational memory of stress in plants. *Nature* 442:1046–1049
- Morris KV, Chan SWL, Jacobsen SE, Looney DJ (2004) Small interfering RNA-induced transcriptional silencing in human cells. *Science* 305:1289–1292
- Munson K, Clark J, Lamparska-Kupsik K, Smith SS (2007) Recovery of bisulfite-converted genomic sequences in the methylation-sensitive qPCR. *Nucleic Acids Res* 35:2893–2903
- Murfett J, Wang XJ, Hagen G, Guilfoyle TJ (2001) Identification of *Arabidopsis* histone deacetylase *HDA6* mutants that affect transgene expression. *Plant Cell* 13:1047–1061
- Nathan D, Ingvarsdottir K, Sterner DE, Bylebyl GR, Dokmanovic M, Dorsey JA, Whelan KA, Krsmanovic M, Lane WS, Meluh PB, Johnson ES, Berger SL (2006) Histone sumoylation is a negative regulator in *Saccharomyces cerevisiae* and shows dynamic interplay with positive-acting histone modifications. *Genes Dev* 20:966–976
- Ng DWK, Chandrasekharan MB, Hall TC (2006) Ordered histone modifications are associated with transcriptional poising and activation of the phaseolin promoter. *Plant Cell* 18:119–132
- Noma K, Allis CD, Grewal SI (2001) Transitions in distinct histone H3 methylation patterns at the heterochromatin domain boundaries. *Science* 293:1150–1155
- Nowak SJ, Corces VG (2000) Phosphorylation of histone H3 correlates with transcriptionally active loci. *Genes Dev* 14:3003–3013
- Ogas J, Kaufmann S, Henderson J, Somerville C (1999) PICKLE is a CHD3 chromatin-remodeling factor that regulates the transition from embryonic to vegetative development in *Arabidopsis*. *Proc Natl Acad Sci USA* 96:13839–13844
- Onodera Y, Haag JR, Ream T, Costa Nunes P, Pontes O, Pikaard CS (2005) Plant nuclear RNA polymerase IV mediates siRNA and DNA methylation-dependent heterochromatin formation. *Cell* 120:613–622
- Owen DJ, Ornaghi P, Yang JC, Lowe N, Evans PR, Ballario P, Neuhaus D, Filetici P, Travers AA (2000) The structural basis for the recognition of acetylated histone H4 by the bromodomain of histone acetyltransferase *gcn5p*. *EMBO J* 19:6141–6149
- Pandey R, Müller A, Napoli CA, Selinger DA, Pikaard CS, Richards EJ, Bender J, Mount DW, Jorgensen RA (2002) Analysis of histone acetyltransferase and histone deacetylase families of *Arabidopsis thaliana* suggests functional diversification of chromatin modification among multicellular eukaryotes. *Nucleic Acids Res* 30:5036–5055
- Parcy F (2005) Flowering: a time for integration. *Int J Dev Biol* 49:585–593
- Penterman J, Zilberman D, Huh JH, Ballinger T, Henikoff S, Fischer RL (2007) DNA demethylation in the *Arabidopsis* genome. *Proc Natl Acad Sci USA* 104:6752–6757
- Perruc E, Kinoshita N, Lopez-Molina L (2007) The role of chromatin-remodeling factor PKL in balancing osmotic stress responses during *Arabidopsis* seed germination. *Plant J* 52:927–936
- Peterson CP, Laniel MC (2005) Histones and histone modifications. *Curr Biol* 14:R546–R551
- Pontes O, Li CF, Nunes PC, Haag J, Ream T, Vitins A, Jacobsen SE, Pikaard CS (2006) The *Arabidopsis* chromatin-modifying nuclear siRNA pathway involves a nucleolar RNA processing center. *Cell* 126:79–92
- Probst AV, Fagard M, Proux F, Mourrain P, Boutet S, Earley K, Lawrence RJ, Pikaard CS, Murfett J, Furner I, Vaucheret H, Mittelsten-Scheid O (2004) *Arabidopsis* Histone Deacetylase HDA6 is required for maintenance of transcriptional gene silencing and determines nuclear organization of rDNA repeats. *Plant Cell* 16:1021–1034
- Rassoulzadegan M, Grandjean V, Gounon P, Vincent S, Gillot I, Cuzin F (2006) RNA-mediated non-mendelian



- inheritance of an epigenetic change in the mouse. *Nature* 441:469–474
- Ries G, Heller W, Puchta H, Sandermann H, Seidlitz HK, Hohn B (2000) Elevated UV-B radiation reduces genome stability in plants. *Nature* 406:98–101
- Ronaghi M, Karamohamed S, Pettersson B, Uhlen M, Nyren P (1996) Real-time DNA sequencing using detection of pyrophosphate release. *Anal Biochem* 242:84–89
- Ronaghi M, Uhlen M, Nyren P (1998) A sequencing method based on real-time pyrophosphate. *Science* 281:363–365
- Ronemus M, Vaughn MW, Martienssen RA (2006) MicroRNA-targeted and small interfering RNA-mediated mRNA degradation is regulated by argonaute, dicer and RNA-dependent RNA polymerase in *Arabidopsis*. *Plant Cell* 18:1559–1574
- Rossi V, Locatelli S, Varotto S, Donn G, Pirona R, Henderson DA, Hartings H, Motto M (2007) Maize histone deacetylase hda101 is involved in plant development, gene transcription and sequence-specific modulation of histone modification of genes and repeats. *Plant Cell* 19:1145–1162
- Roth SY, Denu JM, Allis CD (2001) Histone acetyltransferases. *Annu Rev Biochem* 70:81–120
- Sanger F, Nicklen S, Coulson AR (1977) DNA sequencing with chain-terminating inhibitors. *Proc Natl Acad Sci USA* 74:5463–5467
- Santos-Rosa H, Schneider R, Bannister AJ, Sherriff J, Bernstein BE, Emre NC, Schreiber SL, Mellor J, Kouzarides T (2002) Active genes are tri-methylated at K4 of histone H3. *Nature* 419:407–411
- Schumacher A, Kapranov P, Kaminsky Z, Flanagan J, Assadzadeh A, Yau P, Virtanen C, Winegarden N, Cheng J, Gingeras T, Petronis A (2006) Microarray-based DNA methylation profiling: technology and applications. *Nucleic Acids Res* 34:528–542
- Scippa GS, Griffiths A, Chiatante D, Bray EA (2000) The H1 histone variant of tomato, H1-S, is targeted to the nucleus and accumulates in chromatin in response to water-deficit stress. *Planta* 211:173–181
- Scippa GS, Di Michele M, Onelli E, Patrignani G, Chiatante D, Bray EA (2004) The histone-like protein H1-S and the response of tomato leaves to water deficit. *J Exp Bot* 55:99–109
- Scott RJ, Spielman M (2006) Genomic imprinting in plants and mammals: how life history constrains convergence. *Cytogenet Genome Res* 113:53–67
- Shiio Y, Eisenman RN (2003) Histone sumoylation is associated with transcriptional repression. *Proc Natl Acad Sci USA* 100:13225–13230
- Shilatifard A (2006) Chromatin modifications by methylation and ubiquitination: implications in the regulation of gene expression. *Annu Rev Biochem* 75:243–269
- Smith EM, Hoi JT, Eissenberg JC, Shoemaker JD, Neckameyer WS, Ilvarsonn AM, Harshman LG, Schlegel VL, Zempleni J (2007) Feeding *Drosophila* a biotin-deficient diet for multiple generations increases stress resistance and lifespan and alters gene expression and histone biotinylation patterns. *J Nutr* 137:2006–2012
- Song CP, Agarwal M, Ohta M, Guo Y, Halfter U, Wang P, Zhu JK (2005) Role of an *Arabidopsis* AP2/EREBP-type transcriptional repressor in abscisic acid and drought stress responses. *Plant Cell* 17:2384–2396
- Sridha S, Wu K (2006) Identification of AtHD2C as a novel regulator of abscisic acid responses in *Arabidopsis*. *Plant J* 46:124–133
- Sridhar VV, Kapoor A, Zhang K, Zhu J, Zhou T, Hasegawa PM, Bressan RA, Zhu JK (2007) Control of DNA methylation and heterochromatic silencing by histone H2B deubiquitination. *Nature* 447:735–738
- Sterner DE, Berger SL (2000) Acetylation of histones and transcription-related factors. *Microbiol Mol Biol Rev* 64:435–459
- Steward N, Ito M, Yamaguchi Y, Koizumi N, Sano H (2002) Periodic DNA methylation in maize nucleosomes and demethylation by environmental stress. *J Biol Chem* 277:37741–37746
- Stewart FJ, Raleigh EA (1998) Dependence of McrBC cleavage on distance between recognition elements. *Biol Chem* 379:611–616
- Stockinger EJ, Mao Y, Regier MK, Triezenberg SJ, Thomashow MF (2001) Transcriptional adaptor and histone acetyltransferase proteins in *Arabidopsis* and their interactions with CBF1, a transcriptional activator involved in cold regulated gene expression. *Nucleic Acids Res* 29:1524–1533
- Sung S, Amasino RM (2005) Remembering winter: toward a molecular understanding of vernalization. *Annu Rev Plant Biol* 56:491–508
- Sunkar R, Zhu JK (2004) Novel and stress-regulated microRNAs and other small RNAs from *Arabidopsis*. *Plant Cell* 16:2001–2019
- Sunkar R, Chinnusamy V, Zhu J, Zhu JK (2007) Small RNAs as big players in plant abiotic stress responses and nutrient deprivation. *Trends Plant Sci* 12:301–309
- Tani E, Polidoros AN, Naniou-Obeidat I, Tsaftaris AS (2005) DNA methylation patterns are differentially affected by planting density in maize inbreds and their hybrids. *Maydica* 50:19–23
- Tapia G, Verdugo I, Yañez M, Ahumada I, Theoduloz C, Cordero C, Poblete F, González E, Ruiz-Lara S (2005) Involvement of ethylene in stress-induced expression of the *TLCl.1* retro-transposon from *Lycopersicon chilense* Dun. *Plant Physiol* 138:2075–2086
- Tost J, Gut IG (2007) DNA methylation analysis by pyrosequencing. *Nat Protoc* 2:2265–2275
- Tsuji H, Saika H, Tsutsumi N, Hirai A, Nakazono M (2006) Dynamic and reversible changes in histone H3-Lys4 methylation and H3 acetylation occurring at submergence-inducible genes in rice. *Plant Cell Physiol* 47:995–1003
- Ulrich HD (2005) Mutual interactions between the SUMO and ubiquitin systems: A plea of no contest. *Trends Cell Biol* 15:525–532

- Vaillant I, Paszkowski J (2007) Role of histone and DNA methylation in gene regulation. *Curr Opin Plant Biol* 10:528–533
- Vaucheret H, Fagard M (2001) Transcriptional gene silencing in plants: targets, inducers and regulators. *Trends Genet* 17:29–35
- Vlachonasios KE, Thomashow MF, Triezenberg SJ (2003) Disruption mutations of ADA2b and GCN5 transcriptional adaptor genes dramatically affect *Arabidopsis* growth, development and gene expression. *Plant Cell* 15:626–638
- Wada Y, Miyamoto K, Kusano T, Sano H (2004) Association between up-regulation of stress-responsive genes and hypomethylation of genomic DNA in tobacco plants. *Mol Genet Genom* 271:658–666
- Waddington CH (1939) An introduction to modern genetics. Allen and Unwin, London
- Wang H, Huang ZQ, Xia L, Feng Q, Erdjument-Bromage H, Strahl BD, Briggs SD, Allis CD, Wong J, Tempst P, Zhang Y (2001) Methylation of histone H4 at arginine 3 facilitating transcriptional activation by nuclear hormone receptor. *Science* 293:853–857
- Wojdacz TK, Dobrovic A (2007) Methylation sensitive-high resolution melting (MS-HRM): a new approach for sensitive and high-throughput assessment of methylation. *Nucleic Acids Res* 35:e41
- Wu Ct, Morris JR (2001) Genes, genetics and epigenetics: a correspondence. *Science* 293:1103–1105
- Xie Z, Johansen LK, Gustafson AM, Kasschau KD, Lellis AD, Zilberman D, Jacobsen SE, Carrington JC (2004) Genetic and functional diversification of small RNA pathways in plants. *PLoS Biol* 2:642–652
- Yamaguchi T, Blumwald E (2005) Developing salt-tolerant crop plants: challenges and opportunities. *Trends Plant Sci* 10:615–620
- Yamaguchi-Shinozaki K, Shinozaki K (2006) Transcriptional regulatory networks in cellular responses and tolerance to dehydration and cold stresses. *Annu Rev Plant Biol* 57:781–803
- Yoshikawa M, Peragine A, Park MY, Poethig RS (2005) A pathway for the biogenesis of trans-acting siRNAs in *Arabidopsis*. *Genes Dev* 19:2164–2175
- Zhang X, Yazaki J, Sundaresan A, Cokus S, Chan SW, Chen H, Henderson IR, Shinn P, Pellegrini M, Jacobsen SE, Ecker JR (2006) Genome-wide high-resolution mapping and functional analysis of DNA methylation in *Arabidopsis*. *Cell* 126:1189–1201
- Zhang Y (2003) Transcriptional regulation by histone ubiquitination and deubiquitination. *Genes Dev* 17:2733–2740
- Zheng X, Zhu J, Kapoor A, Zhu JK (2007) Role of *Arabidopsis* AGO6 in siRNA accumulation, DNA methylation and transcriptional gene silencing. *EMBO J* 26:1691–1701
- Zhou C, Zhang L, Duan J, Miki B, Wu K (2005) Histone deacetylase19 is involved in jasmonic acid and ethylene signaling of pathogen response in *Arabidopsis*. *Plant Cell* 17:1196–1204
- Zhu J, Dong CH, Zhu JK (2007a) Interplay between cold-responsive gene regulation, metabolism and RNA processing during plant cold acclimation. *Curr Opin Plant Biol* 10:290–295
- Zhu J, Jeong J, Zhu Y, Sokolchik I, Miyazaki S, Zhu JK, Hasegawa PM, Bohnert HJ, Shi H, Yun DJ, Bressan RA (2007b) Involvement of *Arabidopsis* HOS15 in histone deacetylation and cold tolerance. *Proc Natl Acad Sci USA* 105:494–4950
- Zhu J, Kapoor A, Sridhar VV, Agius F, Zhu JK (2007c) The DNA glycosylase/lyase ROS1 functions in pruning DNA methylation patterns in *Arabidopsis*. *Curr Biol* 17:54–59
- Zilberman D, Gehring M, Tran RK, Ballinger T, Henikoff S (2007) Genome-wide analysis of *Arabidopsis thaliana* DNA methylation uncovers interdependence between methylation and transcription. *Nat Genet* 39:61–69

# Part III

## Physiology and Metabolism

## Ion Homeostasis

Anna Amtmann\*

*Plant Science Group, Faculty of Biomedical and Life Science, University  
of Glasgow, Glasgow G128Q, UK*

Roger Leigh

*School of Agriculture, Food and Wine, Waite Campus, University of Adelaide,  
PMB 1, Glen Osmond, South Australia-5152Australia*

Summary .....	245
I Introduction .....	246
II The Need for Ion Homeostasis in Salt Tolerance .....	246
III Essential Components and Parameters of an 'Ion Homeostat' .....	247
A Models for Plant Ion Homeostasis .....	247
B Driving Force and Fluxes .....	250
IV Strategies for Na <sup>+</sup> Homeostasis .....	251
A Cellular Na <sup>+</sup> Homeostasis .....	251
B Tissue Na <sup>+</sup> Homeostasis .....	253
V Transporters Involved in Na <sup>+</sup> Homeostasis .....	253
A Transporters Involved in Cellular Na <sup>+</sup> Uptake .....	253
B Transporters Involved in Cellular Na <sup>+</sup> Export .....	255
C Transporters Involved in Na <sup>+</sup> Compartmentalization .....	255
D Transporters Involved in Long Distance Transport of Na <sup>+</sup> .....	256
VI Conclusions and Outlook .....	257
Acknowledgements .....	259
References .....	259

### Summary

Ion concentrations in cell compartments and tissues are maintained within particular limits that are optimal for plant performance. In this chapter we recapitulate the general processes that are needed for a functional ion homeostat and propose models of how these may apply to the regulation of ion concentrations in single cells and multicellular tissues. The role of K<sup>+</sup> and Na<sup>+</sup> homeostasis in the response of plants to salinity is then discussed, with particular emphasis on how cytoplasmic Na<sup>+</sup> accumulation is minimized. The relative importance of Na<sup>+</sup> exclusion, extrusion, and compartmentalization are considered. Finally the molecular mechanisms underlying these three strategies are described and their potential role in one model of tissue Na<sup>+</sup> homeostasis in salt-grown plants is discussed.

**Keywords:** Ion homeostasis • ion transport • salinity • salt tolerance • telescope model • mineral nutrition

---

\*Author for correspondence, e-mail: a.amtmann@bio.gla.ac.uk



## I Introduction

Ion homeostasis describes the capacity of living organisms to control the concentration of an ion within a defined space despite fluctuating concentrations in the environment. This is an essential aspect of plant function with ion concentrations being regulated for a variety of reasons including providing optimum ionic conditions for enzyme activities, maintenance of turgor pressure around particular values, and signalling. Examples of ion homeostasis include maintenance of vacuolar  $K^+$  concentrations at around 200 mM in barley shoots (Leigh and Johnston 1983; Walker et al. 1996), regulation of cytosolic  $K^+$  concentrations at 100 mM in both roots and shoots except in  $K$ -deficient conditions (Walker et al. 1996; Cuin et al. 2003), the maintenance of steady cytoplasmic  $P_i$  concentrations despite fluctuating concentrations in the vacuole (Lee and Ratcliffe 1983), and the rapid restoration of cytosolic free-calcium ion concentrations  $[Ca^{2+}]_{\text{cyt}}$  after perturbation in signalling (Sanders et al. 2002). Here we discuss in particular the need for ion homeostasis in salt tolerance of plants because preventing large accumulations of  $Na^+$  in plant tissues and sub-cellular compartments is a key aspect of the ability of plants to grow in adverse, salty conditions. We describe the general principles of ion homeostasis, the evidence for  $Na^+$  homeostasis in salt-grown plants, and current knowledge about the transporters that contribute to this.

## II The Need for Ion Homeostasis in Salt Tolerance

Regulation of  $[Ca^{2+}]_{\text{cyt}}$  is one of the best understood examples of ion homeostasis because it has been studied extensively due to the universal role of cytosolic  $Ca^{2+}$  as a second messenger. Transient

elevation of  $[Ca^{2+}]_{\text{cyt}}$  is part of nearly all plant stress responses and this role depends on quick restoration of a low concentration after a transient  $Ca^{2+}$  influx. A number of transport proteins in the plasma membrane and the endo-membranes are involved in  $[Ca^{2+}]_{\text{cyt}}$ -homeostasis. Rapid  $Ca^{2+}$  influx into the cytosol from the apoplast or intracellular organelles is mediated by  $Ca^{2+}$ -channels, which are membrane proteins that allow transport of  $Ca^{2+}$  down their electrochemical gradient. These channels are regulated by voltage and are often activated by  $Ca^{2+}$ , thereby creating a positive feedback loop that leads to  $Ca^{2+}$ -induced  $Ca^{2+}$  release (Bewell et al. 1999; Sanders et al. 2002). Subsequent removal of  $Ca^{2+}$  from the cytosol requires active transport, mediated by  $Ca^{2+}$ -ATPases (Axelsen and Palmgren 2001). These are activated by  $Ca^{2+}$ -binding proteins such as calmodulin, thereby creating a negative feedback loop, which is typical for homeostatic systems (Harper 2001).

Apart from the ubiquitous relevance of  $[Ca^{2+}]_{\text{cyt}}$ -homeostasis for plant stress signalling, homeostasis of sodium ( $Na^+$ ) and potassium ( $K^+$ ) ions is of particular importance for plant salt tolerance (Amtmann et al. 2004). The need for  $K^+$ / $Na^+$  homeostasis under salt stress is indicated by the fact that high concentrations of  $Na^+$  in the cytoplasm are toxic for metabolically active cells, and that  $Na^+$  toxicity is closely related to disruption of essential  $K^+$  functions.  $K^+$  is not only the most important osmoticum in plants – a function in which it can partly be replaced by  $Na^+$  or other solutes, but also provides a beneficial physico-chemical environment for proteins, and more specifically acts as co-factor for a number of enzymes (Leigh and Wyn Jones 1984). By contrast,  $Na^+$  in high concentrations generally destabilises proteins and specifically out-competes  $K^+$  at enzyme interaction sites without being able to replace it as a co-factor (Serrano 1996; Serrano et al. 1999). In unicellular systems, such as yeast or cultured rice cells, a decrease of the  $K^+/Na^+$  ratio to a value below three appears to be toxic (Amtmann et al. 2001; Obata et al. 2007).

At the whole-plant level  $K^+/Na^+$  ratios seem to be more tightly controlled in some cells than others. Using multi-barrelled ion selective electrodes, Miller and co-workers demonstrated not only homeostatic maintenance of cytoplasmic  $K^+$  in barley root cells, when challenged with varying

---

*Abbreviations:* ABA – abscisic acid; AKT1 – *Arabidopsis*  $K^+$  transporter-type channels; CBLs – calcineurin B-like proteins; CaM – calmodulin; CHX – cation exchangers; CIPK – CBL-interacting protein kinase; CNGC – cyclic-nucleotide gated channel; GLR – glutamate receptor; HAK/HKT – high-affinity  $K^+$  transporter type transporters;  $K^+$  – potassium ions; KEA –  $K^+$  exchange anti-porter; KUP –  $K^+$  uptake permease; NHX1 –  $Na^+/H^+$  exchanger;  $Na^+$  – sodium ions; SKOR1 – stellar  $K^+$  outward rectifying channel

external  $K^+$  concentrations (Walker et al. 1996), but also maintenance of higher cytoplasmic  $K^+/Na^+$  ratios in a salt-tolerant variety (Gerbel) compared to a salt-sensitive variety (Triumph), when challenged with high external  $Na^+$  concentrations (Carden et al. 2003). The latter experiments also indicated that the contribution of the individual ions to the high cytoplasmic  $K^+/Na^+$  ratio in Gerbel root cells changed over time with maintenance of low  $Na^+$  during early stages of the stress being replaced by maintenance of high  $K^+$  during later stages.

The dogma of cytoplasmic  $K^+$  and  $K^+/Na^+$  homeostasis in plant cells has recently been challenged by Kronzucker and colleagues, who found not only that cytoplasmic  $K^+$  concentrations varied considerably in different nutritional conditions but also that low cytoplasmic  $K^+/Na^+$  ratios did not impact on plant performance under salt stress (Kronzucker et al. 2003, 2006). In these studies, cytoplasmic  $K^+$  and  $Na^+$  concentrations were determined by compartmental analysis of isotope fluxes ( $^{42}K$  and  $^{22}Na$ ) from roots of barley seedlings. Apart from the fact that the assignment of flux components to cellular compartments is difficult when dealing with multicellular tissues, the apparently contradicting results from Carden et al. (2003) and Kronzucker et al. (2006), could be reconciled if one allows for prioritisation of  $K^+/Na^+$  homeostasis in some cell types over others. Thus, the microelectrodes were localised in cortical root cells while the fast ‘cytoplasmic’ component of isotope efflux, used in calculations by Kronzucker and colleagues, is likely to reflect epidermal cells. There is indeed good evidence for differential prioritisation of different cell types with respect to  $K^+/Na^+$  homeostasis in leaves. It might be argued that considerable changes in cytoplasmic  $K^+$  and/or  $K^+/Na^+$  ratio only occur if the homeostatic system of a particular cell is over-stretched, and that the plant will strive to restrict such changes to metabolically less active cell types by prioritising allocation of  $K^+$  and  $Na^+$  at the tissue and whole-plant level.

In accordance with the general opinion in the plant science community, this review considers  $K^+/Na^+$  homeostasis, both at the cellular and at the tissue level, a basic feature of plants and an essential requirement for plant salt tolerance. However, it needs to be remembered that  $K^+/Na^+$  homeostasis in different cell types still

remains to be better underscored with experimental data.

### III Essential Components and Parameters of an ‘Ion Homeostat’

#### A Models for Plant Ion Homeostasis

By analogy with a thermostat that keeps our living rooms at a constant temperature, several components are required and several parameters have to be considered when constructing a device for ion homeostasis (‘homeostat’; Fig. 1). Components include a *sensor* that measures the *actual ion concentration* of the space and compares it with a given *set point* (the *desired ion concentration*),

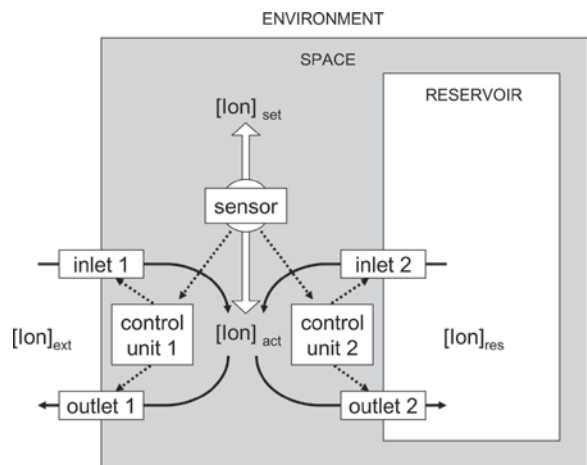

Fig. 1. General model of an ion homeostat. The homeostat aims to maintain a certain ion concentration,  $[Ion]$ , in the controlled space (grey) despite fluctuations of  $[Ion]$  in the environment,  $[Ion]_{ext}$ . Components of the homeostat are a *sensor*, a *control unit*, an *inlet* and an *outlet* for passage of the ion into or out of the space, respectively. The sensor compares the actual ion concentration in the space,  $[Ion]_{act}$ , with the desired concentration,  $[Ion]_{set}$ , and passes the information on to a control unit, which regulates the ion flow into and out of the space through inlet and outlet, respectively (indexed 1). Ion influx or efflux changes  $[Ion]_{act}$  in the direction of  $[Ion]_{set}$  until the sensor reports that it has been reached. Depending on the speed of sensor and control unit, oscillations of  $[Ion]_{act}$  around the set point may occur. An extended version of the homeostat makes use of an internal reservoir, which in addition to the environment can be used to store or supply ions. Inlet and outlet of the reservoir (indexed 2) are controlled by a second control unit, which is again informed by the sensor on  $[Ion]_{act} - [Ion]_{set}$ . Ion flow is indicated by solid arrows, regulation by dashed arrows.

an *inlet* and an *outlet* for ions that can be used to increase or decrease the ion concentration in the space, and a *control unit* that regulates the ion flux through inlet and outlet. The latter is under the command of the sensor thereby forming a regulatory feedback loop. Parameters that have to be considered for efficient running of the homeostat are:

- The actual ion concentration of the space.
- The set point.
- The volume of the space.
- The driving forces for the movement of ions into and out of the space.
- The rates of flux through the inlet and outlet.
- The delay of the control unit.

The relative sizes of these parameters will define the quality of the device, which is the variation of the actual ion concentration around the set point. One way of improving the homeostatic system is to include an ion reservoir that can be used as an overflow if the ion concentration exceeds the set point, and as a ion supply if the ion concentration falls below the set point. This reservoir requires its own control unit, inlet and outlet, and its efficient control requires consideration of parameters analogous to the ones described above (Fig. 1).

How do these components and parameters translate into biological entities? Clearly, some assignments are easier than others; in the case of cellular homeostasis ‘space’ can be translated

into ‘cytoplasm’, ‘environment’ into ‘apoplast’, ‘reservoir’ into ‘vacuole’ (and possibly other single membrane organelles), ‘inlet and outlet’ into ‘transporters’ providing influx and efflux pathways for the ions across the plasma membrane and the tonoplast. Chloroplasts and mitochondria could be considered to represent ‘sub-cellular homeostats’ in themselves. The biological correspondents for ‘sensor’ and ‘control unit’ are more complex. Sensors for cytoplasmic ion concentrations could be proteins that interact with others upon binding of the relevant ion. No regulatory proteins are known that directly bind  $K^+$  or  $Na^+$ . Instead,  $Ca^{2+}$ -binding proteins such as calmodulin and calcineurin B-like proteins (CBLs) can act as sensors and create a link between the external concentrations of  $K^+$  and  $Na^+$  and their transporters via a cytoplasmic  $Ca^{2+}$  signal (Liu and Zhu 1998; Yamaguchi et al. 2005; Li et al. 2006; Xu et al. 2006). Ion sensors can also be intrinsic parts of ion transporters. For example, interaction with extracellular  $K^+$  of the sixth transmembrane-spanning domain of the  $K^+$ -efflux channel SKOR1 results in channel closure (Johansson et al. 2006). A sensor for  $Na^+$  remains to be discovered. In the case of  $K^+$ , homeostatic maintenance of cytoplasmic concentrations of around 100 mM over a wide range of external  $K^+$  concentrations has been measured (Walker et al. 1996), but there is no such information for  $Na^+$ . It is possible that the control unit for  $Na^+$  homeostasis works under the premise of keeping cytoplasmic  $Na^+$  as low

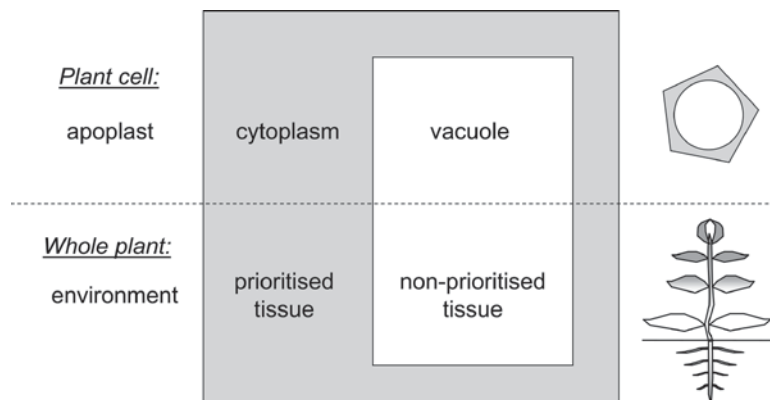

Fig. 2. Biological ion homeostats. The figure depicts biological equivalents of ion homeostats at the level of a single plant cell (*upper part*) and the whole plant (*lower part*). In the cellular model the cytoplasm can be considered a controlled space, the vacuole serves as reservoir and the apoplast is the environment. In the whole plant model the ion concentration is more tightly controlled in some tissues (prioritised, *grey*) than in others (non-prioritised, *white*). Thus, prioritised tissues are the controlled space of the homeostat, while non-prioritised tissues take the role of the reservoir.

as possible, and that a set point only exists for the  $K^+/Na^+$  concentration ratio. ‘Control units’ for ion homeostasis are composed of a complex network of regulatory proteins and ligands. Some of these, including protein kinases and cyclic nucleotides, have been identified and will be described below, but many others remain to be found.

While the plant cell can easily be depicted as a homeostatic system, ion homeostasis at the tissue and whole-plant level is more difficult to conceptualise. In many cases, ion allocation between roots and shoots is at the centre of such consideration and one could depict roots and shoots as two distinct spaces linked by xylem and phloem as ion inlets and outlets. Albeit intuitive from the anatomical point of view, such scheme runs into difficulty when assigning ‘space’, ‘environment’ and ‘reservoir’ as both parts of the plant have mixed properties. In other words, it is not clear which one is prioritised with respect to the control of  $K^+$  and  $Na^+$  concentrations. Although exclusion of  $Na^+$  from the shoot is often considered beneficial under salt stress, a recent compilation of shoot  $Na^+$  concentrations in different plant species, varieties and mutants, argued against a correlation between shoot  $Na^+$  concentration and salt tolerance (Moller and Tester 2007). Furthermore, the shoot itself contains different tissues, which are of greater or lesser importance for plant development (meristem vs. differentiated tissue) or metabolism (younger vs. older leaves or mesophyll vs. epidermis). We therefore propose here a concept in which the entire plant is divided into *prioritised* and *non-prioritised* tissue, representing ‘space’ and ‘reservoir’ respectively (Fig. 2). From an experimental point of view the challenge is then to assign different tissues to these two categories depending on their capacity to maintain constant ion concentrations in the face of varying apoplastic concentrations. To date we still lack experimental information on the homeostatic properties of many tissues but one good example is the differential ion distribution between leaf mesophyll (prioritised) and leaf epidermal cells (non-prioritised) (Fricke et al. 1996; Karley et al. 2000a, b; Cuin et al. 2003; Volkov et al. 2004). Other examples are exclusion of  $Na^+$  from fruits and younger leaves (prioritised) at the cost of older leaves (non-prioritised) (Nakamura et al. 1996; Zhang and Blumwald 2001). Control systems for whole-plant homeostasis employ hormones such as ABA (Zhu et al.

2007; Tran et al. 2007; Hirayama and Shinozaki 2007), but may also make use of metabolites such as glutamate, polyamines and sugars (Dennison and Spalding 2000; Lacombe et al. 2001; Cuin and Shabala 2005, 2007, Amtmann et al. 2005; Ge et al. 2008; Armengaud et al. 2009).

In a third model, which we term the ‘telescope model’, we place a cellular homeostat inside the homeostatic context of the whole plant (Fig. 3). While discussing only two levels of homeostatic control (cell and organism), this model can be extended to an unlimited number of levels (‘telescope’), whereby the distinction between levels should be based on prioritisation of homeostatic control rather than anatomy. By analogy with a telescope where a new segment is extended, when the limits of extensibility of previous segments have been reached, remaining homeostatic capacity of a higher order level can be exploited when the homeostatic capacity of the lower levels is exhausted. In the two-level model shown in Fig. 3, cytoplasm and vacuoles of many individual cells are combined into one cellular homeostat but treated separately depending on whether they are situated in a prioritised or non-prioritised tissue environment. The underlying argument is that all plant cells operate a cellular homeostat and make use of the reservoir function of their vacuoles for as long as possible. The difference between the non-prioritised and the prioritised cellular homeostat is that the former experiences a larger load with ions (for example  $Na^+$ ) or a more severe loss of ions (for example  $K^+$ ) during long-term stress. The cause for such difference could lie in the environment (different delivery of ions to different tissues), or in the membrane properties of the cells (different ion uptake or leakage = Karley et al. 2000a, b). As a result, the homeostatic control of non-prioritised cells ‘collapses’ earlier (or at a milder stress) than that of prioritised cells. Breakdown of ion homeostasis does not necessarily imply cell death but will certainly impact on metabolism and other parameters such as the membrane potential. It is possible that some of these changes, for example, metabolites released into the apoplast, could act as signals to inform prioritised tissues of ion status of non-prioritised tissues (Amtmann et al. 2005, Cuin and Shabala 2007; Armengaud et al. 2009).

Clearly, the ‘telescope’ model can only serve as a prototype, as it over-simplifies the complexity of the system (e.g., the difference between



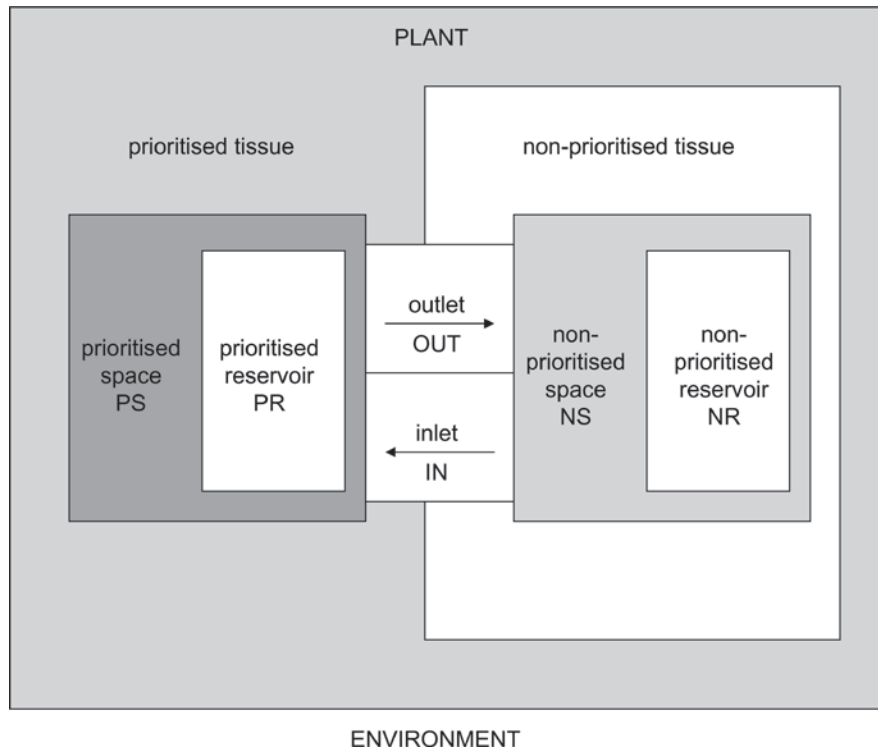

*Fig. 3.* Integrative model combining cellular and whole-plant homeostasis ('telescope model'). In this two-level model, cellular homeostats are placed in a whole-plant context that is itself homeostatic. Thus, changes in the cell environment will be more or less demanding for the cellular homeostats depending on whether they are part of a non-prioritised or prioritised tissue, because these tissues experience differential ion load (depletion). Note that, like a telescope, the scheme can be extended to consider multiple levels spanning from the single cell to the whole plant. The depicted cellular homeostats are collectives of many individual cells, and connected by pathways, which in many cases will be equivalent to long-distance (vascular) transport systems. In a first approach, the shoot could be considered prioritised and the root non-prioritised tissue, in which case the inlet would be equivalent to the xylem and the outlet to the phloem. However, the model allows a more refined separation of individual tissue types. For example, certain shoot cell types (e.g., those situated in older leaves and epidermis) can be included in the non-prioritised collective while specific parts of the root may prove to be prioritised. The model calls for a kinetic analysis of ion contents in different tissues and cell types in response to rapid changes in the environment. The predicted dynamic behaviour of the two-level telescope model system under ion stress is shown in Fig. 5.

prioritised and non-prioritised spaces may be continuous rather than distinct, and some tissues can equilibrate with the outer environment of the plant while others cannot). Nevertheless, the concept is useful for assigning molecular entities to defined functions within a homeostatic system, and to evaluate the relative importance of different transport pathways at a given stage of stress. It also helps us to pinpoint parameters that have to be measured to understand the dynamics and limitations of plant stress adaptation.

### *B Driving Force and Fluxes*

Unlike animal cells that operate a primary  $\text{Na}^+/\text{K}^+$  ATPase in their plasma membrane, which

exchanges  $\text{Na}^+$  for  $\text{K}^+$ , plant cells operate a primary  $\text{H}^+$ -ATPase that extrudes protons, thereby creating a very negative membrane potential (in the range of  $-180$  mV) and a pH gradient (approximately two pH units) across the plasma membrane. Although cells often depolarise (become electrically less negative) under salt stress, the residual negative membrane potential still provides a strong driving force for cation movement into the cells. According to the Nernst equation, a membrane potential of  $-120$  mV allows 100-fold accumulation of  $\text{Na}^+$  in the cytoplasm without the need for additional energy. A high extracellular  $\text{Na}^+$  concentration (approximately 550 mM in sea water and 100 mM in saline soils) further increases the driving force for  $\text{Na}^+$  influx by a factor of at

least 10. Taken together, in a saline environment, cells are subjected to a driving force of approximately  $-180$  mV or ( $-17$  kJ/mol) for entry of  $\text{Na}^+$ , which theoretically allows passive accumulation of  $\text{Na}^+$  inside the cell to concentrations of 100 M. Even in salt-tolerant plants, such as *Suaeda maritima*,  $\text{Na}^+$  concentrations rarely exceed 500 mM in the vacuole and are much lower in the cytosol (Gorham et al. 1983). Consequently, there must be an export of  $\text{Na}^+$ , which requires energy. Higher plants achieve active  $\text{Na}^+$  extrusion with the help of a  $\text{Na}^+/\text{H}^+$  antiporter, which couples the efflux of  $\text{Na}^+$  to an influx of protons. Since saline conditions are often accompanied by neutral to alkaline pH, these transporters cannot necessarily take advantage of the proton motive force established by the  $\text{H}^+$ -ATPase without exploiting the membrane potential. In these conditions  $\text{Na}^+/\text{H}^+$  antiport across the plasma membrane requires an overall positive charge moving into the cytoplasm, which can be provided by a coupling stoichiometry of at least two protons per  $\text{Na}^+$  ion. Movement of  $\text{K}^+$  across the plasma membrane underlies the same rules as detailed above for  $\text{Na}^+$ , but under saline conditions the external  $\text{K}^+$  concentration is approximately tenfold lower than the  $\text{Na}^+$  concentration, and the cytoplasmic set point is relatively high (around 100 mM). Hence, in saline conditions, the driving force for  $\text{K}^+$  uptake is approximately 100 times lower than that for  $\text{Na}^+$ . An exemplary list of driving forces for  $\text{K}^+$  and  $\text{Na}^+$  movement based on measured values of ion concentrations and membrane potentials from two barley varieties was provided by Carden et al. (2003).

Driving forces are important from an energetic point of view, because they tell us whether transport of an ion in a certain direction is passive (i.e., energetically downhill) or requires energy and, if so, how much. However, they do not provide information on how fast the ions accumulate. The time factor is crucial for salt tolerance, as it integrates the uptake of potentially toxic ions with growth. For example, if  $\text{Na}^+$  influx is large compared to the speed with which growth enlarges the available reservoirs,  $\text{Na}^+$  may accumulate to toxic concentrations in the cell cytoplasm, which, in turn, will further slow down growth. Conversely, if growth is faster than  $\text{Na}^+$  influx,  $\text{Na}^+$  can be easily accommodated in the vacuoles. Flux depends on both

the driving force and the permeability of the membrane for the ion, the latter being the sum of the ion permeability of all relevant transport proteins present in the membrane.  $\text{Na}^+$  and  $\text{K}^+$  are primarily taken up into cells by ion channels, which generally exhibit much higher transport rates than co-transport systems (e.g.,  $\text{H}^+$ -linked  $\text{Na}^+$  transporters) or pumps (e.g.,  $\text{H}^+$ -ATPases). Millions of ions per second pass through ion channels, compared to thousands or hundreds through co-transporters and pumps. The relative  $\text{K}^+/\text{Na}^+$  permeability of the membrane as a whole and of individual transporters in the membrane, therefore, plays an important role in plant salt tolerance. Furthermore, in saline conditions  $\text{Na}^+$  and  $\text{K}^+$  concentrations are in the mM range both outside and inside the cell, and thus the respective fluxes are high. In this respect,  $\text{K}^+/\text{Na}^+$  homeostasis is very different from  $\text{Ca}^{2+}$  homeostasis, which deals with a much larger driving force but comparatively smaller fluxes (Amtmann and Sanders 1999). In summary,  $\text{K}^+/\text{Na}^+$  homeostasis under saline conditions presents plants with both an energetic and a kinetic problem. In the following text we will describe different strategies of plants to achieve  $\text{K}^+/\text{Na}^+$  homeostasis during salt stress. We will concentrate on  $\text{Na}^+$  but consider  $\text{K}^+$ , as and when the need arises.

## IV Strategies for $\text{Na}^+$ Homeostasis

### A Cellular $\text{Na}^+$ Homeostasis

Plants use three strategies for maintaining low  $\text{Na}^+$  concentrations inside their cells:

- $\text{Na}^+$  exclusion
- $\text{Na}^+$  extrusion
- $\text{Na}^+$  compartmentalization

Each of these strategies has certain advantages and disadvantages for the plant. Sodium exclusion describes the capacity of a cell to restrict unidirectional  $\text{Na}^+$  influx. The obvious advantage of this strategy is that it minimizes the energy required for active export of  $\text{Na}^+$  back out of the cell. The main problem is to restrict  $\text{Na}^+$  uptake while maintaining uptake capacity for other beneficial ions, in particular  $\text{K}^+$ . Due to the physico-chemical similarity between  $\text{K}^+$  and  $\text{Na}^+$ , the evolutionary

opportunities to design transport proteins, that effectively discriminate between these two ions, are limited. Inward rectifying  $K^+$  channels of the Shaker family are probably the most selective  $K^+$ -transporters, exhibiting a  $K^+$  permeability up to 50-times greater than that for  $Na^+$  (Véry and Sentenac 2002). This means that if these channels are the main pathway for uptake of  $K^+$  and  $Na^+$ , 50-times more  $K^+$  will be taken up from solutions containing equimolar  $K^+$  and  $Na^+$ . Conversely, if the cell is exposed to a solution that contains 50 times more  $Na^+$  than  $K^+$  (e.g., sea water or any aqueous dilution of it), the channels will transport similar amounts of  $K^+$  and  $Na^+$  (assuming independent ion permeation through the channel; Amtmann and Sanders 1999). However, these channels are not the only pathways for uptake of ions and other channels may be far less selective. For instance, plants possess non-selective cation channels, which do not discriminate between monovalent, or even divalent, cations (Demidchik et al. 2002; Demidchik and Maathuis 2007).

Much research has been directed towards understanding the role of non-selective cation channels in plant salt tolerance (Demidchik et al. 2002; Demidchik and Maathuis 2007), and there is some indication that salt-tolerant plants down-regulate these pathways (Wang et al. 2006; Volkov and Amtmann 2006). However, even in the complete absence of non-selective channels, a certain amount of  $Na^+$  leaks into the cells through  $K^+$  channels or other transporters. Efforts to engineer  $K^+$  transporters with increased  $K^+/Na^+$  selectivity, although partly successful (Uozumi et al. 1995; Gassmann et al. 1996; Mäser et al. 2002), clearly have their limits. A potential pitfall of  $Na^+$  exclusion, even if it could be achieved through protein engineering, is that it deprives the plant of its cheapest osmoticum,  $Na^+$ , under saline conditions, and hence other solutes would have to be taken up or produced metabolically to adjust the osmotic pressure of the cell sap and overcome the increased osmotic pressure in the soil solution (Bartels and Sunkar 2005).

Extrusion of accumulated  $Na^+$  is another means to limit net  $Na^+$  influx. The main disadvantage of  $Na^+$  extrusion is its energetic cost. Active  $Na^+$  export in vascular plants is achieved by  $Na^+/H^+$  antiporter that exploits the proton motive force across the plasma membrane. Consequently, *A. thaliana* plants, disrupted in either the antiporter or the

proton pump, show salt-hypersensitive phenotypes (Shi et al. 2000; Vitart et al. 2001). Sodium ion extrusion is a useful means for avoiding  $Na^+$  build-up in root cells as ions extruded to the root apoplast will readily equilibrate with the soil solution. By contrast, the strategy is less effective in leaf cells as it can result in high apoplastic  $Na^+$  concentrations, which will not only increase the driving force for  $Na^+$  uptake but also create an osmotic problem (Oertli 1968; Flowers et al. 1991). Therefore, cellular homeostasis of  $Na^+$  in the leaves mainly relies on sequestration (or compartmentalization) of  $Na^+$  into the vacuole.

Vacuoles occupy up to 90% of the cell volume. Being largely metabolically inactive they provide a 'dumping' ground for many substances that could interfere with cellular metabolism. Accumulation of  $Na^+$  in vacuoles requires energy, but due to a small membrane potential difference across the tonoplast (approximately  $\pm 10$  mV with respect to the cytoplasm; Carden et al. 2003); the energy expenditure is mainly determined by the  $Na^+$  concentration difference between the cytosol and the vacuole. Uptake of  $Na^+$  into the vacuole is powered by a pH gradient established through the combined action of the V-type  $H^+$ -ATPase and the  $H^+$ -PPase (Davies et al. 1992; Sze et al. 1999; Gaxiola et al. 1999, 2001, 2002), and involves  $Na^+/H^+$  antiporters at the plasma membrane (Barkla et al. 1994; Apse et al. 1999; Blumwald 2000; Zhang and Blumwald 2001; Zhang et al. 2001; Apse and Blumwald 2002; Apse et al. 2003). Although this strategy consumes energy, it has the obvious advantage that  $Na^+$  accumulation in the vacuole provides a means for cellular osmotic adjustment during salt stress. However, its ultimate suitability for limiting  $Na^+$  accumulation in the cytoplasm is limited by the maximum concentration that can be accumulated in the vacuole and the volume of vacuolar space available. Thus, it will only be effective in salt stress adaptation if  $Na^+$  influx into the vacuole is accompanied by continuous expansion of the vacuolar space through growth. In addition, accumulation of high concentrations of  $Na^+$  salts in the vacuole must be accompanied by osmotic adjustment in the cytosol, otherwise the cytosol will be dehydrated by water flow into the vacuole. This is often achieved by the accumulation of so-called "compatible solutes" such as glycine betaine or proline in the cytoplasm (Wyn Jones

et al. 1977). These solutes are not disruptive to protein function and can be accumulated to high concentrations without being detrimental (Wyn Jones and Pollard 1983).

### B Tissue $\text{Na}^+$ Homeostasis

Salt toxicity appears first in the leaves and plant salt sensitivity is often, although not always, correlated with leaf  $\text{Na}^+$  levels (Volkov et al. 2004; Wang et al. 2006; Volkov and Amtmann 2006; Moller and Tester 2007; Munns and Tester 2008).  $\text{Na}^+$  homeostasis at the tissue level therefore, puts the shoot in the position of the regulated space in which there needs to be limitations on the concentration of  $\text{Na}^+$  accumulated if detrimental effects are to be avoided. Thus, strategies analogous to those involved in cellular homeostasis must be operating to limit  $\text{Na}^+$  accumulation in the shoot.

Exclusion of  $\text{Na}^+$  from the shoot occurs at the level of net xylem loading, which is the result of release of  $\text{Na}^+$  from root stellar cells into the xylem, and retrieval of  $\text{Na}^+$  from the root xylem. Since the inside of the xylem is generally more electrically positive and more acidic than the cytoplasm of xylem parenchyma cells,  $\text{Na}^+$  uptake into the xylem is active and mediated by  $\text{Na}^+/\text{H}^+$  antiport (Baker and Hall 1988; Munns and Tester 2008). Conversely,  $\text{Na}^+$  retrieval is a passive process unless  $\text{Na}^+$  concentrations in the xylem are very low. As in the case of cellular homeostasis any mechanism resulting in the exclusion of  $\text{Na}^+$  from the shoot needs to ensure maintenance of  $\text{K}^+$  transport. Hence,  $\text{Na}^+$  retrieval from the xylem has to be highly selective for  $\text{Na}^+$  over  $\text{K}^+$ .

Extrusion of  $\text{Na}^+$  from the leaf can be achieved either by its relocation into the root via the phloem, or by active secretion into the environment by specialised cells or organs (salt bladders and salt glands). The latter are common features in halophytic plants, but have limited potential for engineering salt tolerant crops as they are structurally and functionally complex. Manipulation would require interference in developmental pathways that is beyond current capabilities. Little is known about re-translocation of  $\text{Na}^+$  in the phloem, but, at least in *A. thaliana*, its contribution to redistribution of  $\text{Na}^+$  in the root is relatively small (Hall et al. 2006; Davenport et al. 2007).

Storage of  $\text{Na}^+$  in certain areas within the shoot, that are relatively metabolically inert, is the tissue-level equivalent to cellular  $\text{Na}^+$  compartmentalization in the vacuole. This mechanism would be additional to general sequestration of  $\text{Na}^+$  in vacuoles of all leaf cells, which is even more crucial in the shoots than in the roots. The sacrifice/of certain cells for usage as  $\text{Na}^+$  ‘reservoirs’ provides additional capacity for keeping  $\text{Na}^+$  away from metabolically crucial cells. In leaves of salt-treated barley plants, both epidermal and mesophyll cells experience an increase in  $\text{Na}^+$ , and a decrease in  $\text{K}^+$  concentrations, but the changes are more pronounced in epidermal cells than in mesophyll cells (Fricke et al. 1996). Similarly, triple-barellled microelectrode measurements found preferential allocation of  $\text{K}^+$  to the cytoplasm of mesophyll cells in case of salt-stressed barley (Cuin et al. 2003). A comparison between *A. thaliana*, and its salt-tolerant relative *T. halophila*, revealed preferential allocation of  $\text{K}^+$  in leaf mesophyll cells of *T. halophila*, which does not occur in *A. thaliana* (Volkov et al. 2004). In summary, the more tolerant species (barley and *T. halophila*) seem to use differential allocation of  $\text{K}^+$  and  $\text{Na}^+$  between different leaf cell types to achieve higher  $\text{K}^+/\text{Na}^+$  ratios in the mesophyll cells. Furthermore, in barley,  $\text{Na}^+$  is preferentially accumulated in older leaves as compared to younger leaves (Nakamura et al. 1996), a mechanism that not only protects younger leaves from  $\text{Na}^+$  overload but also provides a means for disposal of  $\text{Na}^+$  through leaf shedding. An efficient barrier against  $\text{Na}^+$  also seems to operate at the level of fruits. Thus, tomato plants over-expressing the vacuolar  $\text{Na}^+/\text{H}^+$  antiporter NHX1 showed increased  $\text{Na}^+$  levels in the leaves but not in the fruits (Zhang and Blumwald 2001). Both of these processes are likely to be based on localised  $\text{Na}^+$  retrieval from the xylem within the shoot.

## V Transporters Involved in $\text{Na}^+$ Homeostasis

### A Transporters Involved in Cellular $\text{Na}^+$ Uptake

The study of  $\text{Na}^+$  exclusion requires analysis of transporters that potentially mediate  $\text{Na}^+$  uptake. As discussed earlier, even highly selective  $\text{K}^+$



channels will theoretically allow some  $\text{Na}^+$  uptake if the external  $\text{Na}^+$  concentration is much higher than the external  $\text{K}^+$  concentration. There is, however, some evidence that the  $\text{K}^+$  uptake channel in *A. thaliana*, AKT1, is blocked by cytoplasmic  $\text{Na}^+$  (Qi and Spalding 2004), which would disable this pathway once cytoplasmic  $\text{Na}^+$  concentrations reaches a certain level. Whether under these conditions high-affinity  $\text{K}^+$  transporters (e.g., KUP/HAK and HKT gene families) provide a means for  $\text{K}^+$  uptake remains to be shown, but many of these are also blocked by  $\text{Na}^+$  (Rubio et al. 1995; Spalding et al. 1999; Rodriguez-Navarro 2000). Experiments using the patch clamp electro-physiological technique with protoplasts from mature *A. thaliana* roots (Volkov and Amtmann 2006) or expression of AKT1 in heterologous systems (Gaymard et al. 1996), did not provide evidence for  $\text{Na}^+$  inhibition of  $\text{K}^+$  flow through AKT1 and the significance of  $\text{Na}^+$  blockage of the channel, therefore, remains an open question.

Patch clamp studies have provided ample evidence for the existence of non-selective cation channels in the plasma membrane of plant root cells, in addition to  $\text{K}^+$ -selective channels (White and Lemitiri-Clieh 1995; Amtmann et al. 1997; Roberts and Tester 1997; Tyerman et al. 1997; Demidchik and Tester 2002; Volkov and Amtmann 2006). Non-selective channels are mostly voltage-independent and thus mediate inward currents over a wide range of membrane voltages, in particular at membrane potentials where  $\text{K}^+$  channels are closed (Amtmann and Sanders 1999). The physiological function of the non-selective channels is unclear, with suggestions for their functions including the involvement in  $\text{NH}_4^+$ ,  $\text{Ca}^{2+}$  and  $\text{K}^+$  uptake (White 1996; Volkov and Amtmann 2006; Demidchik and Maathuis 2007). However, the potential danger they represent under saline conditions as a pathway for  $\text{Na}^+$  influx is generally accepted (Tester and Davenport 2003). This  $\text{Na}^+$  influx makes the membrane potential less negative, thus restricting the capacity of the cell for  $\text{K}^+$  uptake because  $\text{K}^+$ -specific channels close at these voltages.

Comparative patch clamp and isotope flux analysis of root protoplasts from *A. thaliana* and *T. halophila* have provided quantitative evidence that restriction of  $\text{Na}^+$  uptake through non-selective voltage-independent pathways

contributes to salt tolerance (Wang et al. 2006; Volkov and Amtmann 2006; Amtmann 2009). Thus, both voltage-independent  $\text{Na}^+$  inward currents and unidirectional  $^{22}\text{Na}$  flux into root cells were approximately two times smaller in *T. halophila* than in *A. thaliana*. Calculations showed that the measured difference in root  $\text{Na}^+$  influx between the two species could account for lower net  $\text{Na}^+$  uptake into leaves of *T. halophila* without any requirement for enhanced  $\text{Na}^+$  efflux. Indeed,  $^{22}\text{Na}$  flux experiments indicated that unidirectional  $\text{Na}^+$  efflux from the roots was smaller in *T. halophila* than in *A. thaliana*. These findings not only emphasise the importance of  $\text{Na}^+$  uptake pathways in the roots for net  $\text{Na}^+$  uptake into the shoot, but also indicate that by diminishing the need for active  $\text{Na}^+$  export, this strategy might put the salt-tolerant species at an energetic advantage.

Unfortunately, identification of the genes underlying voltage-independent  $\text{Na}^+$  currents has proven difficult, although there are a number of potential candidates. Members of the cyclic-nucleotide gated channel (CNGC) family and the glutamate receptor (GLR) family have been considered prime candidates (Lacombe et al. 2001; Davenport 2002; Talke et al. 2003). A role for CNGCs was supported by the observation that  $\text{Na}^+$  inward currents in *A. thaliana* seedlings were inhibited by cyclic GMP (cGMP) and that treatment of the seedlings with cGMP enhanced their salt tolerance (Maathuis and Sanders 2001). However, salt-related phenotypes of transgenic plants with altered expression of CNGCs and GLRs are scarce, probably due to functional redundancy within the large gene families. For example, only a minor increase in salt tolerance and a transient decrease in  $\text{Na}^+$  influx were found in *engc3* knockout mutants (Gobert et al. 2006). Members of both channel families have also proven rather recalcitrant to analysis in heterologous expression systems, but the CNGCs characterised in *Xenopus* oocytes, to date, appear to be activated rather than inhibited by cyclic nucleotides (CNs) (Leng et al. 1999; Leng et al. 2002). Furthermore, most of the observed non-selective currents are not affected by CNs or glutamate. The molecular nature of these currents, therefore, remains a mystery.

Members of the HKT (high affinity  $\text{K}^+$  transporter) family have also been implicated in  $\text{Na}^+$

influx into root cells. For example, *TaHKT2;1*, mediates high affinity  $K^+$  uptake when expressed in *Xenopus* oocytes, which is dependent on the presence of low concentrations of  $Na^+$  in the external medium, suggesting a  $K^+/Na^+$  co-transport mechanism (Rubio et al. 1995). At high  $Na^+$  concentrations,  $Na^+$  out-competes  $K^+$  at the  $K^+$ -binding site and under these conditions *TaHKT1* acts as a  $Na^+/Na^+$  co-transport system mediating low-affinity  $Na^+$  uptake (Gassmann et al. 1996). Both transport modes have since been found for HKT1 homologues in other species (Uozumi et al. 2000; Horie et al. 2001; Liu et al. 2001; Su et al. 2003). The observation that *hkt1* knockout in *A. thaliana* suppresses the *sos1* phenotype supports the notion that HKT1 is involved in  $Na^+$  uptake into roots (Rus et al. 2001). More recently, it was shown that *OsHKT2;1* mediates high-affinity influx of  $Na^+$  into rice roots in low salt conditions, but is quickly down-regulated in high-salt conditions (Horie et al. 2007). Hence, this transporter may provide  $Na^+$  as an alternative osmoticum when  $K^+$  availability is low but its regulation protects plants from  $Na^+$  accumulation in high salinity conditions. HKT genes share a common phylogeny with Shaker-type ion channels, and it is therefore possible that they display channel-type features (Mäser et al. 2002). Unfortunately, to date there is no detailed pharmacological description of HKT1-mediated currents that would allow comparison with voltage-independent currents measured in root protoplasts. However, it should be noted that unequivocal evidence for single channel gating events of voltage-independent 'channels' is also still elusive.

### B Transporters Involved in Cellular $Na^+$ Export

More than 50 genes in *A. thaliana* encode proteins with resemblance to bacterial and fungal antiporters (Mäser et al. 2001). Three gene families in *A. thaliana* have putative functions in active transport of  $K^+$  and/or  $Na^+$ , i.e.,  $K^+$  Exchange Antiporters (KEA), Cation exchangers, (CHX) both members of the CPA2 multigene family, and NHX ( $Na^+$  exchangers) belonging to the CPA1 family of antiporters (Mäser et al. 2001).

Export of  $Na^+$  from root cells is generally assumed to proceed through the  $Na^+/H^+$  antiporter SOS1 (*AtNHX7*), a member of the NHX fam-

ily, which was identified by a forward screen for salt over-sensitivity of *A. thaliana* seedlings (Wu et al. 1996; Shi et al. 2000). SOS1 is predicted to have 12 transmembrane spanning domains and a long C-terminus, which is located in the cytoplasm where it interacts with various regulators (Shi et al. 2000). SOS1 is the target of a regulatory system that is gaining increasing importance in ion transport regulation during plant ionic stress, involving a calcineurin B-like protein (CBL), which recognises a rise in cytoplasmic  $Ca^{2+}$  and a CBL-interacting protein kinase (CIPK), which modulates the activity of a transporter. The  $Ca^{2+}$ -dependent CBL-CIPK interaction recruits the CIPK to the plasma membrane where it activates its target by phosphorylation (Halfter et al. 2000; Quintero et al. 2002; Quan et al. 2007). The SOS pathway involves SOS2 (CIPK24) as the CIPK regulating SOS1. Depending on the tissue, SOS2 interacts with SOS3 (CBL4, in roots) or with CBL10 (in shoots; Quan et al. 2007). An analogous pathway involving CIPK23 and CBL1 (or CBL9) has recently been discovered to regulate the  $K^+$ -uptake channel AKT1 in *A. thaliana* (Xu et al. 2006; Li et al. 2006). Activation of AKT1 through the  $Ca^{2+}$ -dependent CBL/CIPK pathway is not only essential for  $K^+$ -uptake in low  $K^+$  conditions (*cipk23* mutants phenocopy *akt1* mutants), but could also be a means for increasing the overall  $K^+/Na^+$  permeability of the root cells under salt stress (Amtmann and Sanders 1999; Obata et al. 2007). CBLs and CIPKs form a large network with many possible interactions between individual members of both families (Lee et al. 2007), but cellular expression patterns and targets remain to be characterised. In the case of SOS2, additional targets include the vacuolar antiporters NHX1 and CAX1 (Qiu et al. 2004; Cheng et al. 2004).

### C Transporters Involved in $Na^+$ Compartmentalization

*AtNHX1*, also a member of the *A. thaliana* NHX family, is located in the tonoplast and has a role in sequestering  $Na^+$  into the vacuole (Apse et al. 1999). Experiments measuring pH-dependent acridine orange fluorescence in vacuoles isolated from *NHX1* over-expressing *A. thaliana* plants revealed that NHX mediates electro-neutral  $Na^+/H^+$  exchange (Apse et al. 1999). As

with SOS1, a topology of 12 transmembrane spanning domains and a long C-terminus is predicted from the sequence of NHX1. However, hemagglutinin tagging of hydrophilic regions in NHX1 showed that only nine hydrophobic regions span the entire membrane. This suggests a structure in which the N-terminus is located in the cytoplasm and the C-terminus in the vacuole (Yamaguchi et al. 2003). Interestingly, truncation of the C-terminus differentially affects transport rates of  $\text{Na}^+/\text{H}^+$  and  $\text{K}^+/\text{H}^+$ , thus pointing to the possibility that the selectivity of NHX1 is regulated from the vacuolar side. Additional experiments have raised the surprising possibility that this regulation might involve calmodulin (CaM) in the vacuole (Yamaguchi et al. 2003, 2005). Yeast two-hybrid assays showed that a CaM-like protein, AtCaM15, interacts in a  $\text{Ca}^{2+}$ - and pH-dependent manner with the C-terminus of AtNHX1. CaM binding to NHX1 decreases  $V_{\max}$  of  $\text{Na}^+/\text{H}^+$  antiport without changing  $V_{\max}$  of  $\text{K}^+/\text{H}^+$  antiport. Hence, regulation of NHX1 by vacuolar CaM might provide a molecular switch between  $\text{K}^+$  and  $\text{Na}^+$  transport.

Over-expression of *NHX1* in *A. thaliana* as well as *Brassica napus* and *Lycopersicon esculentum* increases salt tolerance of mature plants (Apse et al. 1999; Zhang et al. 2001; Zhang and Blumwald 2001). It is surprising that salt-tolerance can be achieved through increased vacuolar compartmentalization alone, without the necessity to restrict root  $\text{Na}^+$  uptake or to enhance active  $\text{Na}^+$  extrusion. As discussed above,  $\text{Na}^+$  compartmentalization is limited by the overall vacuolar volume of leaf cells and one would, therefore, predict that salt tolerance in *NHX1* over-expressing plants would be closely related to growth and transpiration rates as well as development. Such relationships need further investigation in various environments and agricultural settings before *NHX1* over-expression can be considered a general cure for salt-sensitivity in crops.

Two further members of the *Arabidopsis* *NHX* family (*NHX2* and *NHX5*) were identified on the basis of sequence similarity to *NHX1* and analysed with respect to  $\text{Na}^+$  transport and transcriptional regulation by salt (Yokoi et al. 2002). Like *NHX1* they are expressed in roots and shoots, localise to the tonoplast and suppress  $\text{Na}^+$ - and  $\text{Li}^+$ -sensitive phenotypes in

yeast. They differ, however, in transcriptional regulation. Whereas, *NHX1* and *NHX2* are up-regulated by osmotic stress ( $\text{Na}^+$  and sorbitol) in an abscisic acid (ABA)-dependent fashion, *NHX5* responds only to ionic stress ( $\text{Na}^+$ ) and this response is ABA-independent (Yokoi et al. 2002). In summary, it appears that many *NHX*-type transporters are involved in active  $\text{Na}^+$  extrusion from the cytoplasm but differ from each other with respect to membrane location and regulation.

#### D Transporters Involved in Long Distance Transport of $\text{Na}^+$

Several types of transporters have been implicated in long-distance transport of  $\text{Na}^+$  between roots and shoots. SOS1, discussed above as mediating  $\text{Na}^+$  export from epidermal root cells, is also strongly expressed in xylem parenchyma cells. Interestingly, the effect of *sos1* knockout on shoot  $\text{Na}^+$  concentration depends on the amount of external  $\text{Na}^+$  (Shi et al. 2002). Under high-salt conditions (100 mM NaCl) *sos1* plants show increased  $\text{Na}^+$  levels in the shoot, whereas in low-salt conditions (25 mM NaCl), the case is opposite. This has been explained with a function of SOS1 in xylem  $\text{Na}^+$  loading under low-salt conditions and in  $\text{Na}^+$ -retrieval from the xylem under high-salt conditions (Shi et al. 2002). Whether there is an electrochemical basis for such dual mechanism remains to be investigated by measuring electrochemical gradients for  $\text{Na}^+$  and  $\text{H}^+$  across the xylem parenchyma plasma membrane in the specific conditions. A member of the CHX family has also been implicated in xylem loading. CHX21 localises to the root endodermis, and its knockout leads to decreased  $\text{Na}^+$  levels both in the xylem and in the leaves (Hall et al. 2006).

Increasing evidence points to a role of HKT genes in  $\text{Na}^+$  retrieval from the xylem. While Berthomieu et al. (2003) suggested a role for *AtHKT1;1* in phloem loading (in the shoots) and unloading (in the roots) Sunarpi et al. (2005), localised *AtHKT1;1* to the plasma membrane of leaf xylem parenchyma cells and measured increased  $\text{Na}^+$  levels in shoot xylem in *hkt1;1* mutants. They concluded that *AtHKT1;1* retrieves  $\text{Na}^+$  from the xylem in shoots, and that any observed effect on phloem  $\text{Na}^+$  content is secondary.

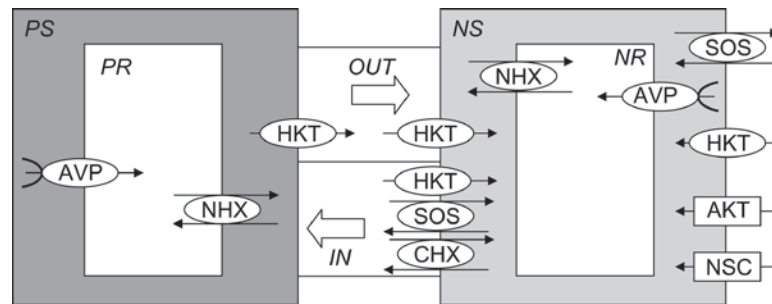

Fig. 4. Tentative assignment of plant transporter families to the telescope model. For simplicity only the cellular components of the model presented in Fig. 12.3 are shown. PS, PR, NS and NR stand for prioritised space, prioritised reservoir, non-prioritised space and non-prioritised reservoir, IN and OUT for inlet and outlet (see Fig. 3). Both K<sup>+</sup>-selective (e.g., AKT1) and non-selective channels (NSC) provide pathways for Na<sup>+</sup> uptake into cells but there is some evidence that their relative abundance differs between prioritised and non-prioritised tissues (e.g., leaf epidermis and mesophyll). Members of the HKT gene family have been implicated in Na<sup>+</sup> uptake into root epidermal cells but their main importance lies in the retrieval of Na<sup>+</sup> from the xylem (IN), although a function in loading and un-loading of the phloem (OUT) has also been proposed. Active export of Na<sup>+</sup> from cells is mediated by SOS1, which, together with a member of the CHX family, also provides a means for regulating long-distance Na<sup>+</sup> flux in the xylem. Compartmentalization of Na<sup>+</sup> into the vacuolar reservoirs by NHX1 homologues occurs in both prioritised and non-prioritised tissues, and is supported by the action of proton pumps such as the H<sup>+</sup>-PPase, AVP1. For details and references see main text.

Radiotracer flux experiments further supported a role of *AtHKT1;1* in Na<sup>+</sup> retrieval from the xylem (Davenport et al. 2007). In addition to reverse genetics approaches with *hkt* knockout mutants, QTL analyses of wheat accessions provided further evidence for the involvement of HKT1 genes in root-shoot Na<sup>+</sup> homeostasis. Mapping of a K<sup>+</sup>/Na<sup>+</sup> discrimination locus (*Kna1*) (Gorham et al. 1997) in bread wheat suggested *TaHKT1;5* as the gene determining this locus (Byrt et al. 2007). A closely related gene *TmHKT1;4* is present in the genome area underlying a K<sup>+</sup>/Na<sup>+</sup> discrimination locus (*Nax1*) in durum wheat (James et al. 2006; Huang et al. 2006). In both cases, low Na<sup>+</sup> shoot levels in the respective lines are likely to be the result of Na<sup>+</sup> retrieval from the root xylem.

The way these different types of transporters might fit into the telescope model of ion homeostasis in tissues (Fig. 3) is shown in Fig. 4. The picture represents a scenario in which prioritised cells (shown on the left side of Fig. 4) are protected against Na<sup>+</sup> overload through: (a) retrieval of Na<sup>+</sup> from the inlet by HKT1, SOS1 and CHX21-type transporters, and (b) absence of significant Na<sup>+</sup> uptake pathways (e.g., non-selective channels or HKT1-type transporters). The cells can cope with the remaining Na<sup>+</sup> through sequestration in their vacuoles by NHX1-type transporters in conjunction with the H<sup>+</sup>-PPase (AVP1-type). The non-prioritised cell (shown on

the right side of Fig. 4) is subject to higher load Na<sup>+</sup> and consequently homeostasis will break down earlier despite energy-consuming active export through SOS1-type antiporters. This scenario is only one possible interpretation of the collated data, and much more detailed experimental data will be required to consolidate the specific role of individual transporters within a homeostatic system.

## VI Conclusions and Outlook

Control of ion concentrations (homeostasis) is a fundamental feature of living organisms. While cellular Ca<sup>2+</sup> homeostasis provides the basis for Ca<sup>2+</sup>-signals in response to many biotic and abiotic stimuli, homeostasis of K<sup>+</sup> and Na<sup>+</sup>, both at the cellular and at the tissue level, is particularly important for plant salt tolerance. Homeostatic systems are equipped with defined components and are determined by a number of parameters. Intensive research in the area of plant salt tolerance has identified many transport pathways and the underlying genes as potential components of a Na<sup>+</sup> homeostat, and has characterised some of the regulatory elements controlling them. However, there is still a profound void in our understanding of how these different pathways are connected and how the different control units are integrated



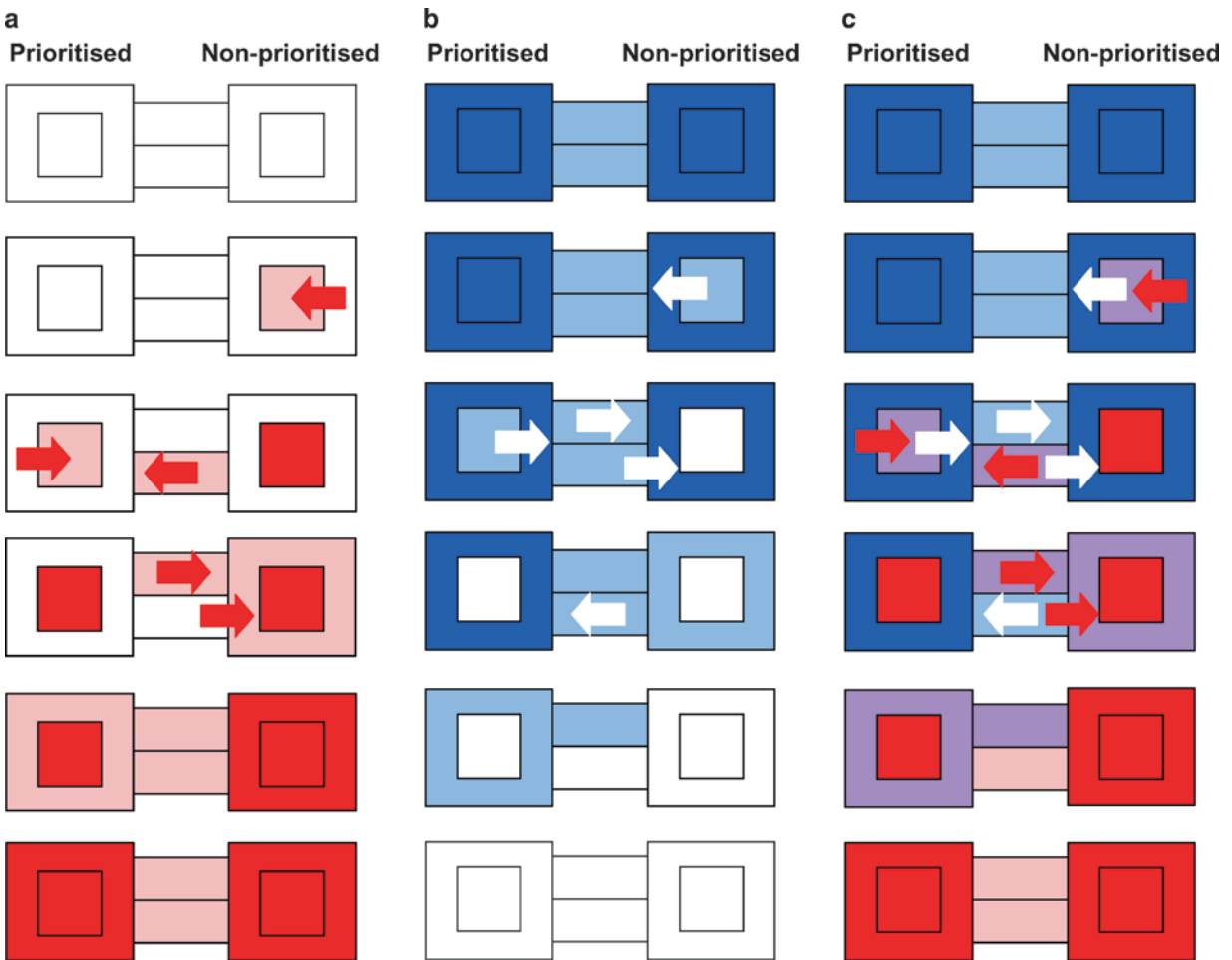

**Fig. 5.** (a) Predicted dynamic behaviour of the telescope model during salt stress; (b)  $K^+$ -deficiency stress; (c) and combined stress. For simplicity only the collective cellular components of the model, presented in Fig. 12.3, are shown. Stress progresses from top to bottom either in time or strength. Colours indicate high (red for  $Na^+$  and blue for  $K^+$ ), low (white) or changing ion concentrations (pink for  $Na^+$  accumulation, light blue for  $K^+$  depletion). Arrows indicate the movement of  $Na^+$  (red) and  $K^+$  (white) that is most crucial for the homeostatic behaviour of the system at a given stage of the stress. C is a simple overlay of A and B with  $K^+/Na^+$  ratios being high (blue), low (red) or intermediate (purple). During early (mild) stress, homeostasis is achieved by making use of cellular reservoirs in non-prioritised tissues. If the stress persists cellular reservoirs in prioritised tissues are exploited to maintain homeostasis in both tissue types. Only when both resources are exhausted cellular spaces will start changing. However, homeostatic control at the whole-plant level assures that this happens first in non-prioritised tissues [See Color Plate 5, Fig. 9].

at the whole-plant level. We are also still lacking essential information on some of the basic parameters such as cytoplasmic  $Na^+$  concentrations, and electric potentials of phloem and xylem. With information on individual genes rapidly increasing it will be important to integrate this information into sound conceptual models that allow us to interpret, predict and test their roles within the homeostatic system.

Considering the predicted dynamic behaviour of a model that combines cellular with tissue

homeostasis (Fig. 5) it is clear that at different stages of the stress (e.g., salinity or  $K^+$  deficiency), some pathways are more crucial for homeostasis than others. Much of the reported controversy concerning the functions of individual transporters (e.g., HKT1 and SOS1) may in fact be resolved by considering the specific homeostatic status of the respective transgenic plants in the applied condition. In addition to steady-state measurements under a range of conditions it will be necessary to explore the dynamic behaviour of systems that

lack or over-express these genes over an extended course of stress and in response to varying stress doses. Whether a particular salt treatment is 'physiological' or not has been frequently discussed, but it is clear that in order to understand the functional components of a homeostat we have to disturb it and test its limits. Approached in a dynamic and systematic manner, plant salt tolerance will continue to be an exciting area of research, likely to reveal many novel aspects of fundamental biological functions and biological engineering with potential benefits in agricultural production in sub-optimal salinized soils.

## Acknowledgements

We are grateful to Mike Blatt for fruitful discussion. Research in the laboratory of A. Amtmann is supported by the Biotechnology and Biological Sciences Research Council (BBSRC), the Leverhulme Trust and FBLS.

## References

- Amtmann A (2009) Learning from evolution: *Thellungiella* generates new knowledge on essential and critical components of abiotic stress tolerance in plants. *Mol Plant* 2:3–12
- Amtmann A, Sanders D (1999) Mechanisms of Na<sup>+</sup> uptake by plant cells. *Adv Bot Res* 29:75–112
- Amtmann A, Laurie S, Leigh R, Sanders D (1997) Multiple inward channels provide flexibility in Na<sup>+</sup>/K<sup>+</sup> discrimination at the plasma membrane of barley suspension culture cells. *J Exp Bot* 48:481–497
- Amtmann A, Fischer M, Marsh EL, Stefanovic A, Sanders D, Schachtman DP (2001) The wheat cDNA LCT1 generates hypersensitivity to sodium in a salt-sensitive yeast strain. *Plant Physiol* 126:1061–1071
- Amtmann A, Armengaud P, Volkov V (2004) Potassium nutrition and salt stress. In: Blatt MR (ed) *Membrane transport in plants*. Blackwell Publishing, Oxford, pp 293–339
- Amtmann A, Hammond JP, Armengaud P, White PJ (2005) Nutrient sensing and signalling in plants: potassium and phosphorus. In: Callow JA (ed) *Advances in botanical research incorporating advances in plant pathology*, vol. 43. Academic Press, New York, pp 209–257
- Apse MP, Blumwald E (2002) Engineering salt tolerance in plants. *Curr Opin Biotech* 13:146–150
- Apse MP, Aharon GS, Snedden WA, Blumwald E (1999) Salt tolerance conferred by over-expression of a vacuolar Na<sup>+</sup>/H<sup>+</sup> antiporter in *Arabidopsis*. *Science* 285:1256–1258
- Apse MP, Sottosanto JB, Blumwald E (2003) Vacuolar cation/H<sup>+</sup> exchange, ion homeostasis and leaf development are altered in a T-DNA insertional mutant of AtNHX1, the *Arabidopsis* vacuolar Na<sup>+</sup>/H<sup>+</sup> antiporter. *Plant J* 36:229–239
- Armengaud P, Sulpice R, Miller AJ, Stitt M, Anna Amtmann A, Gibon Y (2009) Multi-level analysis of primary metabolism provides new insights into the role of potassium nutrition for glycolysis and nitrogen assimilation in *Arabidopsis thaliana* roots. *Plant Physiol* 150:772–785
- Axelsen KB, Palmgren MG (2001) Inventory of the superfamily of P-type ion pumps in *Arabidopsis*. *Plant Physiol* 126:696–706
- Baker DA, Hall JL (1988) *Solute transport in plant cells and tissues*. Longman Scientific and Technical, Harlow, Essex, UK
- Barkla BJ, Apse MP, Manolson MF, Blumwald E (1994) The plant vacuolar Na<sup>+</sup>/H<sup>+</sup> antiport. *Symp Soc Exp Biol* 48:141–153
- Bartels D, Sunkar R (2005) Drought and salt tolerance in plants. *Crit Rev Plant Sci* 24:23–58
- Berthomieu P, Conejero G, Nublat A, Brackenbury WJ, Lambert C, Savio C, Uozumi N, Oiki S, Yamada K, Cellier F, Gosti F, Simonneau T, Essah PA, Tester M, Very AA, Sentenac H, Casse F (2003) Functional analysis of AtHKT1 in *Arabidopsis* shows that Na<sup>+</sup> recirculation by the phloem is crucial for salt tolerance. *EMBO J* 22:2004–2014
- Bewell MA, Maathuis FJM, Allen GJ, Sanders D (1999) Calcium-induced calcium release mediated by a voltage-activated cation channel in vacuolar vesicles from red beet. *FEBS Lett* 458:41–44
- Blumwald E (2000) Sodium transport and salt tolerance in plants. *Curr Opin Cell Biol* 12:431–434
- Byrt CS, Platten JD, Spielmeyer W, James RA, Lagudah ES, Dennis ES, Tester M, Munns R (2007) HKT1;5-like cation transporters linked to Na<sup>+</sup> exclusion loci in wheat, Nax2 and Kna1. *Plant Physiol* 143:1918–1928
- Carden DE, Walker DJ, Flowers TJ, Miller AJ (2003) Single-cell measurements of the contributions of cytosolic Na<sup>+</sup> and K<sup>+</sup> to salt tolerance. *Plant Physiol* 131:676–683
- Cheng NH, Pittman JK, Zhu JK, Hirschi KD (2004) The protein kinase SOS2 activates the *Arabidopsis* H<sup>+</sup>/Ca<sup>2+</sup> antiporter CAX1 to integrate calcium transport and salt tolerance. *J Biol Chem* 279:2922–2926
- Cuin TA, Shabala S (2005) Exogenously supplied compatible solutes rapidly ameliorate NaCl-induced potassium efflux from barley roots. *Plant Cell Physiol* 46:1924–1933
- Cuin TA, Shabala S (2007) Amino acids regulate salinity-induced potassium efflux in barley root epidermis. *Planta* 225:753–761
- Cuin TA, Miller AJ, Laurie SA, Leigh RA (2003) Potassium activities in cell compartments of salt-grown barley leaves. *J Exp Bot* 54:657–661
- Davenport R (2002) Glutamate receptors in plants. *Ann Bot* 90:549–557
- Davenport R, Munoz-Mayor A, Jha D, Essah PA, Rus A, Tester M (2007) The Na<sup>+</sup> transporter AtHKT1;1 controls

- retrieval of  $\text{Na}^+$  from the xylem in *Arabidopsis*. *Plant Cell Environ* 30:497–507
- Davies JM, Poole RJ, Rea PA, Sanders D (1992) Potassium-transport into plant vacuoles energized directly by a proton-pumping inorganic pyrophosphatase. *Proc Natl Acad Sci USA* 89:11701–11705
- Demidchik V, Maathuis FJM (2007) Physiological roles of nonselective cation channels in plants: from salt stress to signalling and development. *New Phytol* 175:387–404
- Demidchik V, Tester M (2002) Sodium fluxes through nonselective cation channels in the plasma membrane of protoplasts from *Arabidopsis* roots. *Plant Physiol* 128:379–387
- Demidchik V, Davenport RJ, Tester M (2002) Non-selective cation channels in plants. *Annu Rev Plant Biol* 53: 67–107
- Dennison KL, Spalding EP (2000) Glutamate-gated calcium fluxes in *Arabidopsis*. *Plant Physiol* 124:1511–1514
- Flowers TJ, Hajibagheri MA, Yeo AR (1991) Ion accumulation in the cell-walls of rice plants growing under saline conditions – evidence for the Oertli hypothesis. *Plant Cell Environ* 14:319–325
- Fricke W, Leigh RA, Tomos AD (1996) The intercellular distribution of vacuolar solutes in the epidermis and mesophyll of barley leaves changes in response to  $\text{NaCl}$ . *J Exp Bot* 47:1413–1426
- Gassmann W, Rubio F, Schroeder JI (1996) Alkali cation selectivity of the wheat root high-affinity potassium transporter HKT1. *Plant J* 10:869–882
- Gaxiola RA, Rao R, Sherman A, Grisafi P, Alper SL, Fink GR (1999) The *Arabidopsis thaliana* proton transporters, AtNhx1 and Avp1, can function in cation detoxification in yeast. *Proc Natl Acad Sci USA* 96:1480–1485
- Gaxiola RA, Li J, Undurraga S, Dang LM, Allen GJ, Alper SL, Fink GR (2001) Drought- and salt-tolerant plants result from over-expression of the AVP1  $\text{H}^+$ -pump. *Proc Natl Acad Sci USA* 98:11444–11449
- Gaxiola RA, Fink GR, Hirschi KD (2002) Genetic manipulation of vacuolar proton pumps and transporters. *Plant Physiol* 129:967–973
- Gaymard F, Cerutti M, Horeau C, Lemaillet G, Urbach S, Ravallec M, Devauchelle G, Sentenac H, Thibaud JB (1996) The baculovirus/insect cell system as an alternative to *Xenopus* oocytes – first characterization of the AKT1  $\text{K}^+$  channel from *Arabidopsis thaliana*. *J Biol Chem* 271:22863–22870
- Ge LF, Chao DY, Shi M, Zhu MZ, Gao JP, Lin HX (2008) Over-expression of the trehalose-6-phosphate phosphatase gene OsTPP1 confers stress tolerance in rice and results in the activation of stress responsive genes. *Planta* 228:191–201
- Gobert A, Park G, Amtmann A, Sanders D, Maathuis FJM (2006) *Arabidopsis thaliana* Cyclic Nucleotide Gated Channel 3 forms a non-selective ion transporter involved in germination and cation transport. *J Exp Bot* 57:791–800
- Gorham J, Jones RGW (1983) Solute distribution in *Suaeda maritima*. *Planta* 157:344–349
- Gorham J, Bridges J, Dubcovsky J, Dvorak J, Hollington PA, Luo MC, Khan JA (1997) Genetic analysis and physiology of a trait for enhanced  $\text{K}^+/\text{Na}^+$  discrimination in wheat. *New Phytol* 137:109–116
- Halfter U, Ishitani M, Zhu JK (2000) The *Arabidopsis* SOS2 protein kinase physically interacts with and is activated by the calcium-binding protein SOS3. *Proc Natl Acad Sci USA* 97:3735–3740
- Hall D, Evans AR, Newbury HJ, Pritchard J (2006) Functional analysis of CHX21: a putative sodium transporter in *Arabidopsis*. *J Exp Bot* 57:1201–1210
- Harper JF (2001) Dissecting calcium oscillators in plant cells. *Trends Plant Sci* 6:395–397
- Hirayama T, Shinozaki K (2007) Perception and transduction of abscisic acid signals: keys to the function of the versatile plant hormone ABA. *Trends Plant Sci* 12:343–351
- Horie T, Yoshida K, Nakayama H, Yamada K, Oiki S, Shimmyo A (2001) Two types of HKT transporters with different properties of  $\text{Na}^+$  and  $\text{K}^+$  transport in *Oryza sativa*. *Plant J* 27:129–138
- Horie T, Costa A, Kim TH, Han MJ, Horie R, Leung HY, Miyao A, Hirochika H, An G, Schroeder JI (2007) Rice OsHKT2;1 transporter mediates large  $\text{Na}^+$  influx component into  $\text{K}^+$ -starved roots for growth. *EMBO J* 26: 3003–3014
- Huang SB, Spielmeier W, Lagudah ES, James RA, Platten JD, Dennis ES, Munns R (2006) A sodium transporter (HKT7) is a candidate for Nax1, a gene for salt tolerance in durum wheat. *Plant Physiol* 142:1718–1727
- James RA, Davenport RJ, Munns R (2006) Physiological characterization of two genes for  $\text{Na}^+$  exclusion in durum wheat, Nax1 and Nax2. *Plant Physiol* 142:1537–1547
- Johansson I, Wulfetange K, Poree F, Michard E, Gajdanowicz P, Lacombe B, Sentenac H, Thibaud JB, Mueller-Roeber B, Blatt MR, Dreyer I (2006) External  $\text{K}^+$  modulates the activity of the *Arabidopsis* potassium channel SKOR via an unusual mechanism. *Plant J* 46:269–281
- Karley AJ, Leigh RA, Sanders D (2000a) Differential ion accumulation and ion fluxes in the mesophyll and epidermis of barley. *Plant Physiol* 122:835–844
- Karley AJ, Leigh RA, Sanders D (2000b) Where do all the ions go? The cellular basis of differential ion accumulation in leaf cells. *Trends Plant Sci* 5:465–470
- Kronzucker HJ, Szczerba MW, Britto DT (2003) Cytosolic potassium homeostasis revisited:  $\text{K-42}$ -tracer analysis in *Hordeum vulgare* L. reveals set-point variations in  $\text{K}^+$ . *Planta* 217:540–546
- Kronzucker HJ, Szczerba MW, Moazami-Goudarzi M, Britto DT (2006) The cytosolic  $\text{Na}^+:\text{K}^+$  ratio does not explain salinity-induced growth impairment in barley: a dual-tracer study using  $\text{K-42}$  and  $\text{Na-24}$ . *Plant Cell Environ* 29:2228–2237
- Lacombe B, Becker D, Hedrich R, DeSalle R, Hollmann M, Kwak JM, Schroeder JI, Le Novere N, Nam HG, Spalding EP, Tester M, Turano FJ, Chiu J, Coruzzi G (2001) The identity of plant glutamate receptors. *Science* 292:1486–1487

- Lee RB, Ratcliffe RG (1983) phosphorus-nutrition and the intracellular distribution of inorganic phosphate in pea root tips - a quantitative study using P-31-NMR. *J Exp Bot* 34:1222–1244
- Lee SC, Lan WZ, Kim BG, Li LG, Cheong YH, Pandey GK, Lu GH, Buchanan BB, Luan S (2007) A protein phosphorylation/dephosphorylation network regulates a plant potassium channel. *Proc Natl Acad Sci USA* 104:15959–15964
- Leigh RA, Johnston AE (1983) Towards a better understanding of critical nutrient concentrations in crops. *J Science Food Agriculture* 34:265–266
- Leigh RA, Wyn Jones RG (1984) A hypothesis relating critical potassium concentrations for growth to the distribution and functions of this ion in the plant-cell. *New Phytol* 97:1–13
- Leng Q, Mercier RW, Yao W, Berkowitz GA (1999) Cloning and first functional characterization of a plant cyclic nucleotide-gated cation channel. *Plant Physiol* 121:753–761
- Leng Q, Mercier RW, Hua BG, Fromm H, Berkowitz GA (2002) Electrophysiological analysis of cloned cyclic nucleotide-gated ion channels. *Plant Physiol* 128:400–410
- Li L, Kim BG, Cheong YH, Pandey GK, Luan S (2006) A  $Ca^{2+}$  signaling pathway regulates a  $K^{+}$  channel for low-K response in *Arabidopsis*. *Proc Natl Acad Sci USA* 103:12625–12630
- Liu J, Zhu JK (1998) A calcium sensor homolog required for plant salt tolerance. *Science* 280:1943–1945
- Liu W, Fairbairn DJ, Reid RJ, Schachtman DP (2001) Characterization of two HKT1 homologues from *Eucalyptus camaldulensis* that display intrinsic osmosensing capability. *Plant Physiol* 127:283–294
- Maathuis FJ, Sanders D (2001) Sodium uptake in *Arabidopsis* roots is regulated by cyclic nucleotides. *Plant Physiol* 127:1617–1625
- Mäser P, Thomine S, Schroeder JI, Ward JM, Hirschi K, Sze H, Talke IN, Amtmann A, Maathuis FJ, Sanders D, Harper JF, Tchiew J, Gribskov M, Persans MW, Salt DE, Kim SA, Guerinet ML (2001) Phylogenetic relationships within cation transporter families of *Arabidopsis*. *Plant Physiol* 126:1646–1667
- Mäser P, Hosoo Y, Goshima S, Horie T, Eckelman B, Yamada K, Yoshida K, Bakker EP, Shinmyo A, Oiki S, Schroeder JI, Uozumi N (2002) Glycine residues in potassium channel-like selectivity filters determine potassium selectivity in four-loop-per-subunit HKT transporters from plants. *Proc Natl Acad Sci USA* 99:6428–6433
- Moller IS, Tester M (2007) Salinity tolerance of *Arabidopsis*: a good model for cereals? *Trends Plant Sci* 12:534–540
- Munns R, Tester M (2008) Mechanisms of salinity tolerance. *Ann Rev Plant Biol* 59:651–681
- Nakamura T, Ishitani M, Harinasut P, Nomura M, Takabe T (1996) Distribution of glycine betaine in old and young leaf blades of salt-stressed barley plants. *Plant Cell Physiol* 37:873–877
- Obata T, Kitamoto HK, Nakamura A, Fukuda A, Tanaka Y (2007) Rice shaker potassium channel OsKAT1 confers tolerance to salinity stress on yeast and rice cells. *Plant Physiol* 144:1978–1985
- Oertli JJ (1968) Extracellular salt accumulation a possible mechanism of salt injury in plants. *Agrochimica* 12:461–469
- Qi Z, Spalding EP (2004) Protection of plasma membrane  $K^{+}$  transport by the salt overly sensitive1  $Na^{+}/H^{+}$  antiporter during salinity stress. *Plant Physiol* 136:2548–2555
- Qiu QS, Guo Y, Quintero FJ, Pardo JM, Schumaker KS, Zhu JK (2004) Regulation of vacuolar  $Na^{+}/H^{+}$  exchange in *Arabidopsis thaliana* by the salt-overly-sensitive (SOS) pathway. *J Biol Chem* 279:207–215
- Quan RD, Lin HX, Mendoza I, Zhang YG, Cao WH, Yang YQ, Shang M, Chen SY, Pardo JM, Guo Y (2007) SCABP8/CBL10, a putative calcium sensor, interacts with the protein kinase SOS2 to protect *Arabidopsis* shoots from salt stress. *Plant Cell* 19:1415–1431
- Quintero FJ, Ohta M, Shi HZ, Zhu JK, Pardo JM (2002) Reconstitution in yeast of the *Arabidopsis* SOS signaling pathway for  $Na^{+}$  homeostasis. *Proc Natl Acad Sci USA* 99:9061–9066
- Roberts SK and Tester M (1997) A patch clamp study of  $Na^{+}$  transport in maize roots. *J Exp Bot* 48:431–440
- Rodriguez-Navarro A (2000). Potassium transport in fungi and plants. *Biochim Biophys Acta* 1469:1–30
- Rubio F, Gassmann W, Schroeder JI (1995) Sodium-driven potassium uptake by the plant potassium transporter Hkt1 and mutations conferring salt tolerance. *Science* 270:1660–1663
- Rus A, Yokoi S, Sharkhuu A, Reddy M, Lee BH, Matsumoto TK, Koiwa H, Zhu JK, Bressan RA, Hasegawa PM (2001) AtHKT1 is a salt tolerance determinant that controls  $Na^{+}$  entry into plant roots. *Proc Natl Acad Sci USA* 98:14150–14155
- Sanders D, Pelloux J, Brownlee C, Harper JF (2002) Calcium at the crossroads of signaling. *Plant Cell* 14:401–417
- Serrano R (1996) Salt tolerance in plants and microorganisms: toxicity targets and defense responses. *Int Rev Cytol* 165:1–52
- Serrano R, Mulet JM, Rios G, Marquez JA, de Larrinoa IF, Leube MP, Mendizabal I, Pascual-Ahuir A, Proft M, Ros R, Montesinos C (1999) A glimpse of the mechanisms of ion homeostasis during salt stress. *J Exp Bot* 50:1023–1036
- Shi H, Ishitani M, Kim C, Zhu JK (2000) The *Arabidopsis thaliana* salt tolerance gene SOS1 encodes a putative  $Na^{+}/H^{+}$  antiporter. *Proc Natl Acad Sci USA* 97:6896–6901
- Shi H, Quintero FJ, Pardo JM, Zhu JK (2002) The putative plasma membrane  $Na^{+}/H^{+}$  antiporter SOS1 controls long-distance  $Na^{+}$  transport in plants. *Plant Cell* 14:465–477
- Spalding EP, Hirsch RE, Lewis DR, Qi Z, Sussman MR, Lewis BD (1999) Potassium uptake supporting plant growth in the absence of AKT1 channel activity: inhibition by ammonium and stimulation by sodium. *J Gen Physiol* 113:909–918
- Su H, Balderas E, Vera-Estrella R, Golldack D, Quigley F, Zhao CS, Pantoja O, Bohnert JH (2003) Expression of



- the cation transporter MchKT1 in a halophyte. *Plant Mol Biol* 52:967–980
- Sunardi HT, Motoda J, Kubo M, Yang H, Yoda K, Horie R, Chan WY, Leung HY, Hattori K, Konomi M, Osumi M, Yamagami M, Schroeder JI, Uozumi N (2005) Enhanced salt tolerance mediated by AtHKT1 transporter-induced Na<sup>+</sup> unloading from xylem vessels to xylem parenchyma cells. *Plant J* 44:928–938
- Sze H, Li XH, Palmgren MG (1999) Energization of plant cell membranes by H<sup>+</sup>-pumping ATPases: regulation and biosynthesis. *Plant Cell* 11:677–689
- Talke IN, Blaudez D, Maathuis FJ, Sanders D (2003) CNGCs: prime targets of plant cyclic nucleotide signaling? *Trends Plant Sci* 8:286–293
- Tester M, Davenport R (2003) Na<sup>+</sup> tolerance and Na<sup>+</sup> transport in higher plants. *Ann Bot* 91:503–527
- Tran LSP, Urao T, Qin F, Maruyama K, Kakimoto T, Shinozaki K, Yamaguchi-Shinozaki K (2007) Functional analysis of AHK1/ATHK1 and cytokinin receptor histidine kinases in response to abscisic acid, drought and salt stress in *Arabidopsis*. *Proc Natl Acad Sci USA* 104:20623–20628
- Tyerman SD, Skerrett M, Garrill A, Findlay GP, Leigh RA (1997) Pathways for the permeation of Na<sup>+</sup> and Cl<sup>-</sup> into protoplasts derived from the cortex of wheat roots. *J Exp Bot* 48:459–480
- Uozumi N, Gassmann W, Gao YW, Schroeder JI (1995) Identification of strong modifications in cation selectivity in an *Arabidopsis* inward rectifying potassium channel by mutant selection in yeast. *J Biol Chem* 270:24276–24281
- Uozumi N, Kim EJ, Rubio F, Yamaguchi T, Muto S, Tsuboi A, Bakker EP, Nakamura T, Schroeder JI (2000) The *Arabidopsis* HKT1 gene homolog mediates inward Na<sup>+</sup> currents in *Xenopus laevis* oocytes and Na<sup>+</sup> uptake in *Saccharomyces cerevisiae*. *Plant Physiol* 122:1249–1259
- Véry AA, Sentenac H (2002) Cation channels in the *Arabidopsis* plasma membrane. *Trends Plant Sci* 7:168–175
- Vitart V, Baxter I, Doerner P, Harper JF (2001) Evidence for a role in growth and salt resistance of a plasma membrane H<sup>+</sup>-ATPase in the root endodermis. *Plant J* 27:191–201
- Volkov V, Amtmann A (2006) *Thellungiella halophila*, a salt-tolerant relative of *Arabidopsis thaliana*, has specific root ion-channel features supporting K<sup>+</sup>/Na<sup>+</sup> homeostasis under salinity stress. *Plant J* 48:342–353
- Volkov V, Wang B, Dominy PJ, Fricke W, Amtmann A (2004) *Thellungiella halophila*, a salt-tolerant relative of *Arabidopsis thaliana*, possesses effective mechanisms to discriminate between potassium and sodium. *Plant Cell Environ* 27:1–14
- Walker DJ, Leigh RA, Miller AJ (1996) Potassium homeostasis in vacuolate plant cells. *Proc Natl Acad Sci USA* 93:10510–10514
- Wang B, Davenport RJ, Volkov V, Amtmann A (2006) Low unidirectional sodium influx into root cells restricts net sodium accumulation in *Thellungiella halophila*, a salt-tolerant relative of *Arabidopsis thaliana*. *J Exp Bot* 57:1161–1170
- White PJ (1996) The permeation of ammonium through a voltage-independent K<sup>+</sup> channel in the plasma membrane of rye roots. *J Membr Biol* 152:89–99
- White PJ, Lemtiri-Clich F (1995) Potassium current across the plasma membrane of protoplast derived from rye roots: a patch clamp study. *J Exp Bot* 46:497–511
- Wu SJ, Ding L, Zhu JK (1996) SOS1, a genetic locus essential for salt tolerance and potassium acquisition. *Plant Cell* 8:617–627
- Wyn Jones RG, Storey R, Leigh RA, Ahmad N, Pollard A (1977) A hypothesis on cytoplasmic osmoregulation. In: Marre E, Ciferri O (eds) Regulation of cell membrane activities in plants. North Holland Biomedical Press, Amsterdam, pp 121–136
- Wyn Jones RJ, Pollard A (1983) Proteins, enzymes and inorganic ions. In: Lauchli A, Pirson A (eds) Encyclopedia of plant physiology. Springer, Berlin, pp 528–562
- Xu J, Li HD, Chen LQ, Wang Y, Liu LL, He L, Wu WH (2006) A protein kinase, interacting with two calcineurin B-like proteins, regulates K<sup>+</sup> transporter AKT1 in *Arabidopsis*. *Cell* 125:1347–1360
- Yamaguchi T, Apse MP, Shi H, Blumwald E (2003) Topological analysis of a plant vacuolar Na<sup>+</sup>/H<sup>+</sup> antiporter reveals a luminal C terminus that regulates antiporter cation selectivity. *Proc Natl Acad Sci USA* 100:12510–12515
- Yamaguchi T, Aharon GS, Sottosanto JB, Blumwald E (2005) Vacuolar Na<sup>+</sup>/H<sup>+</sup> antiporter cation selectivity is regulated by calmodulin from within the vacuole in a Ca<sup>2+</sup>- and pH-dependent manner. *Proc Natl Acad Sci USA* 102:16107–16112
- Yokoi S, Quintero FJ, Cubero B, Ruiz MT, Bressan RA, Hasegawa PM, Pardo JM (2002) Differential expression and function of *Arabidopsis thaliana* NHX Na<sup>+</sup>/H<sup>+</sup> antiporters in the salt stress response. *Plant J* 30:529–539
- Zhang HX, Blumwald E (2001) Transgenic salt-tolerant tomato plants accumulate salt in foliage but not in fruit. *Nat Biotech* 19:765–768
- Zhang HX, Hodson JN, Williams JP, Blumwald E (2001) Engineering salt-tolerant *Brassica* plants: characterization of yield and seed oil quality in transgenic plants with increased vacuolar sodium accumulation. *Proc Natl Acad Sci USA* 98:12832–12836
- Zhu SY, Yu XC, Wang XJ, Zhao R, Li Y, Fan RC, Shang Y, Du SY, Wang XF, Wu FQ, Xu YH, Zhang XY, Zhang DP (2007) Two calcium-dependent protein kinases, CPK4 and CPK11, regulate abscisic acid signal transduction in *Arabidopsis*. *Plant Cell* 19:3019–3036

## Glutathione Homeostasis: Crucial for Abiotic Stress Tolerance in Plants

Bhumesh Kumar, Sneh Lata Singla-Pareek, and Sudhir K. Sopory\*  
*Plant Molecular Biology, International Center for Genetic Engineering  
and Biotechnology, Aruna Asaf Ali Marg, New Delhi-110067, India*

Summary .....	263
I Introduction.....	264
II Regulation of Biosynthesis, Turnover and Compartmentation of Glutathione .....	265
III Uptake and Transport of Glutathione.....	266
IV Quantification of Redox Status and its Modulation by Abiotic Stresses.....	267
V Changes in Glutathione Homeostasis in Plants Under Abiotic Stresses .....	267
A Salt Stress .....	268
B Water Deficit .....	270
C Low Temperature.....	270
D Ozone Toxicity .....	271
E Heavy Metals Toxicity .....	272
VI Protein Oxidation Under Abiotic Stresses .....	273
VII Glutathione as Signaling Molecule and Role of Glutaredoxins.....	273
VIII Crosstalk and Interaction with Other Biomolecules .....	276
IX Conclusions and Perspectives.....	278
Acknowledgements .....	278
References .....	278

### Summary

Glutathione is a non-protein low molecular weight tripeptide that plays an important role in cell function and metabolism. The cellular glutathione/glutathione disulfide redox buffer provides homeostasis by maintaining the redox state of other thiol compounds, avoiding their unnecessary oxidation and thus keeping them in the reduced state. Besides involvement in ascorbate-glutathione cycle, glutathione is also critical for the detoxification of xenobiotics, sequestration of heavy metals and other processes involved in environmental stress tolerance. Involvement of glutathione in post-translational modification by the process of glutathionylation prevents proteins from oxidation. The reversible formation of a mixed disulfide between glutathione and cysteine residue on the target protein brings about conformational

---

\*Author for correspondence, e-mail, [sopory@icgeb.res.in](mailto:sopory@icgeb.res.in)

changes and alters the activity of several important proteins through signaling cascade. The precise mechanisms involved in the formation of mixed-disulfides *in vivo* are largely unknown especially in higher plants. Glutaredoxins catalyze the reverse reaction of glutathionylation which is known as deglutathionylation. Environmental stresses affect the redox status of the cell which 'in turn' triggers signaling cascade pathway(s) leading to the altered physiology of the plants. In this chapter, an attempt has been made to highlight the involvement of glutathione in redox regulation and its crosstalk with other pathways particularly under environmental stresses in plants.

**Keywords** Abiotic stress • glutathione • glutathionylation • protein oxidation • reactive oxygen species • redox homeostasis

## I Introduction

Environmental stresses impose a serious threat to agricultural production globally and development of crops which are tolerant to these unfavorable factors is the need of the hour. The generation of reactive oxygen species (ROS) such as superoxide ( $\text{O}_2^-$ ), hydrogen peroxide ( $\text{H}_2\text{O}_2$ ) and hydroxyl radicals ( $\text{OH}^\cdot$ ) under stress conditions results in DNA damage, protein degradation and lipid peroxidation, thus adversely affecting cellular metabolism. Plants have evolved a complex antioxidant system to prevent the harmful effects of ROS. The titer of ROS in any cellular component is governed by the antioxidant system comprising the ascorbate-glutathione cycle, superoxide dismutase and other antioxidant enzymes (Noctor and Foyer 1998).

Glutathione is a major water-soluble non-protein thiol compound present in plant tissues; it accounts for 1–2% of the total sulfur compounds.

---

*Abbreviations:* GUS – beta-glucuronidase; BSO – buthionine sulfoximine; CaM – calmodulin; CuZnSOD – CuZn superoxide dismutase; 2-Cys-Prxs – 2-cysteine peroxiredoxin; DNA – deoxyribonucleic acid; DTT – 1, 4-dithiothreitol; GRX – glutaredoxin; GS – glutathione conjugates; GSSG – glutathione disulfide (oxidized); GPX – glutathione-dependent peroxidase; GSH – glutathione (reduced); GR – glutathione reductase; GST – glutathione-S-transferase; GFP – green fluorescent protein; MAPK – mitogen-activated protein kinase; NAD – nicotinamide adenine dinucleotide; NADP – nicotinamide adenine dinucleotide phosphate; PMSR – protein methionine sulfoxide reductase; NADPH – reduced nicotinamide adenine dinucleotide phosphate; Srx – sulphiredoxin; TRX – thioredoxin; 5'-UTR – 5'- untranslated region; YFP – yellow fluorescent protein

It can be considered as a storage and transportable form of reduced sulfur, and is known to act as a redox sensor for environmental stress. Reduced glutathione (GSH) protects plant cells from the oxidative damage based on its redox buffering action and abundance in the cell. Involvement of GSH in the ascorbate-glutathione cycle results in its conversion to the disulfide form (GSSG), especially when plants are subjected to environmental stress that alters glutathione biosynthesis. Therefore, glutathione (GSH/GSSG) homeostasis provides a useful link between environmental stress factors and mechanisms involved in physiological and molecular adaptation processes in plants. It is also implicated in the sequestration of xenobiotics and heavy metals, regulation of cell division, induction of antioxidant defense, redox sensing signaling and regulation of chloroplast gene transcription etc. (Meyer and Hell 2005). Increase in cellular GSH level, by improving GSH biosynthetic capacity or through manipulation of glutathione reductase (GR) activity that converts GSSG back into GSH, has been shown to enhance resistance to oxidative stress as well as to abiotic stresses in plants (Zhu et al. 1999; Singla-Pareek et al. 2006). Another important aspect of GSH is its interaction with other important biomolecules like ascorbic acid and hydrogen peroxide in signaling events. Foyer et al. (1997) and Morita et al. (1999) suggested that  $\text{H}_2\text{O}_2$  alone or with GSH may act as an intercellular and systemic signaling system to achieve tolerance to environmental stresses. In this chapter, a comprehensive account of the role(s) of GSH in abiotic stress tolerance, with an emphasis on signaling events and coordination at various levels, is presented.

## II Regulation of Biosynthesis, Turnover and Compartmentation of Glutathione

Biosynthesis of GSH is a two-step enzymatic reaction, first conjugation of cysteine and glutamate is catalyzed by  $\gamma$ -glutamylcysteine synthetase ( $\gamma$ -ECS) to form  $\gamma$ -glutamylcysteine ( $\gamma$ -EC). In the second step, addition of glycine to  $\gamma$ -EC to form the tripeptide GSH is catalyzed by GSH synthetase (GSH-S). The activity of  $\gamma$ -ECS limits the rate of GSH synthesis in plants under most of the unfavorable conditions. It has been shown that mutation in the  $\gamma$ -ECS gene substantially lowered tissue GSH concentration (Xiang et al. 2001). Under normal condition, the dipeptide  $\gamma$ -EC is present at very low levels as it is utilized further by GSH-S to produce GSH. However, in plants over-expressing  $\gamma$ -ECS, it was found that the level of  $\gamma$ -EC increased greatly and such a situation can be attributed to insufficient availability of glycine (Noctor et al. 1997). In fact, a shift in the regulation from  $\gamma$ -ECS to GSH-S was found when glycine was abundant in  $\gamma$ -ECS over-expressing plants (Noctor et al. 2000). This suggests that the over-expression of both the enzymes together can increase the potential for constitutive enhancement of tissue GSH as compared to that achieved by  $\gamma$ -ECS over-expression alone. Thorough examination of the available evidence suggests that the most important factors controlling plant GSH are the activity of  $\gamma$ -ECS and the availability of cysteine. This contention is very well supported by the observation of a coordinated regulation of synthesis of cysteine and GSH (Noctor et al. 1997; Xiang et al. 2001).

Biosynthesis of GSH is influenced by various abiotic stresses. The transcript level of  $\gamma$ -ECS and GSH-S increased by treatment with heavy metals like cadmium in *Brassica juncea* (Schäfer et al. 1998) and by cadmium and copper in *Arabidopsis* (Xiang and Oliver 1998). Transcripts of  $\gamma$ -ECS accumulated in response to chilling in maize (Gomez et al. 2004) while ozone toxicity and catalase deficiency (which led to build up of photorespiratory  $H_2O_2$ ) resulted in a significant increase in  $\gamma$ -ECS and GSH-S transcripts (Harada et al. 2000). Along with the control at transcription level, GSH synthesis may be up-regulated by oxidation-induced increase at the translational level. The 5'-UTR of the  $\gamma$ -ECS gene was found

to interact with a repressor-binding protein, that was released upon the addition of  $H_2O_2$  (Xiang and Bertrand 2000). This mechanism could be of immense significance as all the environmental stress factors invariably trigger the production of ROS, thus the above role of  $H_2O_2$  in removing repressor-binding protein from the 5'-UTR of the  $\gamma$ -ECS gene certainly provides a lead in dissection of the signaling events under abiotic stresses. In mammals, a smaller regulatory subunit in  $\gamma$ -ECS acts to increase the catalytic potential of the larger catalytic subunit by increasing the  $K_i$  for GSH and decreasing the  $K_m$  for glutamate, thus, alleviating feedback control and allowing the enzyme to operate effectively under in vivo conditions (Huang et al. 1993). This observation initiated the speculation concerning the presence of a regulatory subunit in plants also; however, no conclusive evidence has been produced indicating the existence of a regulatory subunit. As in mammals, another level of control may occur through phosphorylation of  $\gamma$ -ECS (Sun et al. 1996) but again no such evidence is available in plants. Inhibition of  $\gamma$ -ECS by dithiols in tobacco and *Arabidopsis* (Jez et al. 2004) points out that transient oxidation of an inhibited enzyme could be one way in which GSH synthesis is kick-started in oxidative conditions; however, it remains to be established whether thiol-disulphide exchange is important mechanism in regulating the in vivo activity of the  $\gamma$ -ECS.

The enzymes of GSH biosynthetic pathway are nuclear encoded and may or may not contain target sequences for chloroplasts in green tissue. Their sub-cellular localization varies from species to species (Hell and Bergmann 1990). Presently, there is no evidence for the presence of GSH biosynthesis enzymes in mitochondria and it appears that the mitochondrial GSH is synthesized in the cytoplasm; however, crucial transport steps and proteins involved in the migration of GSH to mitochondria are unknown. Detailed analysis of the 5'ends of GSH1 and GSH2 mRNAs demonstrated the sub-cellular targeting of the proteins encoded by different transcript types. GSH1 transcript analysis revealed two mRNA populations with short and long 5'-UTRs and both having the entire target peptide sequence. Transient transformation experiments with reporter gene fusions, bearing long or short 5'-UTRs, indicated an exclusive targeting of GSH1 to the plastids. However, two



transcripts of *GSH-S* varying in length, which encode two different protein products were targeted to plastids and cytosol (Wachter et al. 2005). The cytosolic enzyme is translated from shorter transcripts lacking the chloroplast target sequence. This study also indicates the possibility of metabolite transport across the compartments. Import of light and ATP independent GSH in wheat chloroplasts (Noctor et al. 2002) suggested that it may be 'in part' due the activity of an exchange transporter which transports cytosolic GSH to chloroplasts in exchange with  $\gamma$ -EC. This contention is further strengthened by the presence of high concentration of GSH in the chloroplast which could at least partially be dependent on the import of GSH from the cytosol. The contribution of the two compartments to GSH synthesis may vary during development, between different cell types, as a function of physiological status, nature and magnitude of various abiotic stress factors (Noctor et al. 2002 and references therein). A transporter with high specificity to GSH has been cloned from *Arabidopsis* and transcripts of this transporter were shown to be induced by xenobiotic exposure; however, no such induction was observed by  $H_2O_2$  or cadmium treatment (Cagnac et al. 2004). Clearly, more work is needed to understand the regulation of GSH transport and compartmentation in response to stress.

Homeostasis of GSH is not only dependent on the synthesis, but also on the turnover of the glutathione pool. During light periods, higher GSH content was observed in spruce needles as compared to that in the dark period which was ascribed either to its degradation during the night (Schupp and Rennenberg 1988) or higher availability of free glycine synthesized through photorespiration (Noctor et al. 1997). Further, this contention is supported by a marked accumulation of  $\gamma$ -EC, the immediate precursor of GSH, concomitant with a decline of GSH during the dark period in poplar plants (Noctor et al. 1997). Long-term incubation of cells or plants with BSO (buthionine sulfoximine), a potent and highly specific inhibitor of  $\gamma$ -glutamylcysteine synthetase, lowers the level of GSH (Hartmann et al. 2004). Electrophilic xenobiotics also deplete glutathione pool by utilizing it in the detoxification reaction catalyzed by GSTs forming glutathione conjugates (Edwards et al. 2000). These conjugates are further sequestered into the vacuole by the action of ABC-transporters

(ATP-binding cassette transporters) and degraded within the vacuole leading to a gradual accumulation of the cysteine (Rea et al. 1998; Meyer and Fricker 2002). Degradation of GSH by a carboxypeptidase has been shown in tobacco (Steinkamp and Rennenberg 1985). In soybean, the initial step of GSH degradation is catalyzed by a  $\gamma$ -glutamyl transpeptidase (Bergmann and Rennenberg 1993). Two different membrane associated  $\gamma$ -glutamyl transpeptidase were analyzed from tomato and found to be active as hydrolases at low pH (Martin and Slovin 2000). Four isoenzymes of  $\gamma$ -glutamyl transpeptidase were reported in *Arabidopsis*; however, only one *AtGGT1* was found to be associated with plasma membrane (Storozhenko et al. 2002).

### III Uptake and Transport of Glutathione

Feeding experiment with radio-labeled GSH ( $^{35}S$ -GSH) was performed with a 1-year-old single spruce needle as well as a 4–5 year old trees and translocation of the radiotracer was investigated after 3 h incubation in light. In both sets of experiment, 3–16% of the applied radioactivity was taken up by the needle resulting in 54–77% export to the preferential sinks, that is the current year's sprouts. These results suggest that GSH can readily be exchanged between phloem and xylem in both directions (Schneider et al. 1994). Elevated GSH content was observed in all tissues when GSH ( $1 \text{ mmol l}^{-1}$ ) was supplied to the roots of 12 days old bean seedlings. GSH content increased 22 fold in the roots, fivefold in leaves and 3.5-fold in apex after 4 h treatment. This shows that the translocation of GSH occurs through xylem to the above ground parts and also to the underground root system (Tausz et al. 2004).

Transport of GSH across the cell membranes is another aspect drawing attention of the researchers. A yeast (*Saccharomyces cerevisiae*) mutant (*hgt1*) which is deficient in GSH transport was used to characterize a GSH transporter cDNA (*OsGT1*) from rice (*Oryza sativa*). Complementation of *hgt1* mutant with *OsGT1* cDNA restored growth on a medium containing GSH as the sole sulfur source. The strain expressing *OsGT1* mediated [ $^3H$ ]GSH uptake which was significantly competed not only by unlabeled GSSG

and GS conjugates but also by some amino acids and peptides, pointing to a wide substrate specificity and suggesting that OsGT1 may be involved in the retrieval of GSSG, GS conjugates, and nitrogen-containing peptides from the cell wall (Zhang et al. 2004). Molecular cloning, physical mapping and heterologous expression of *AtMRP2* from *A. thaliana* which encodes a multispecific ABC transporter competent in the transport of both GS conjugates and chlorophyll catabolites has been achieved (Lu et al. 1998). Incubation of wheat chloroplasts with <sup>35</sup>S-labelled GSH resulted in time-dependent uptake that was linear for at least 15 min (Noctor et al. 2000). Uptake kinetics obtained from this study suggested that at least two systems are able to take up GSH across the chloroplast envelope, one showing high affinity but lower saturation capacity while another system exhibits lower affinity and higher capacity. These results also suggested that the two forms of glutathione (GSH, GSSG) can be transported by a common system, although GSH appears to be preferred one.

#### IV Quantification of Redox Status and its Modulation by Abiotic Stresses

Maintenance of intracellular redox status seems to be essential for DNA synthesis, gene expression, enzymatic activity and other processes. Thiol-containing molecules, such as GSH, thioredoxins, glutaredoxins and peroxiredoxins play an important role in redox homeostasis. Mechanism of the functional redox homeostasis can be explored separately at the chloroplast, mitochondria and cytoplasm level as the amount as well as redox state of the glutathione pools can be different in sub-cellular compartments (Bergmann and Rennerberg 1993). Sub-cellular compartments other than the vacuole are considered to be functional sites having both GSH and GSSG, thus providing a cellular glutathione redox buffer. Despite limitations in determining the absolute volume of a cell and heterogeneity of the cells within a tissue, efforts are being made to find a suitable system for the quantification and localization of GSH. Use of GSH-specific fluorescent labeling with monochlorobimane, which forms a GSH-S-bimane conjugate and allows the measurement of fluorescence intensity by laser scanning microscopy

techniques (Meyer et al. 2001; Hartmann et al. 2004) can be a convenient method for quantifying the glutathione status in plant tissues.

In addition to the GSH quantification, dependency of the glutathione redox system on pH affects the quantification of redox potential and redox state in separate compartments (Schafer and Buettner 2001). Light-induced changes of stromal pH alter the redox system in chloroplasts. This problem becomes even more complicated by the fact that GSH level itself exhibits diurnal fluctuations because of light dependent changes like availability of glycine, which originates from photorespiration and/or on the developmental state of cells (Ogawa et al. 2004). To overcome these problems, modified redox sensitive probes GFP and YFP, which contain two cysteine residues artificially incorporated into protein barrel, have been used and proved to be powerful tools to monitor the redox changes in single cells or even organelles under any given condition (Hanson et al. 2004). These redox-sensitive probes can interact and form a disulfide bridge depending on the redox potential.

#### V Changes in Glutathione Homeostasis in Plants Under Abiotic Stresses

Environmental stresses increase the production of ROS. To cope with the excess oxidative load, plants have developed antioxidant defense systems involving both enzymatic and non-enzymatic mechanisms (Dionisio-Sese and Tobita 1998). A modulation in the activity of antioxidant enzymes and changes in ascorbate and GSH concentrations in response to environmental stresses can lead to enhanced tolerance against abiotic stresses. Antioxidant defense reactions, which use GSH as an electron donor for the regeneration of ascorbate from its oxidized form 'dehydroascorbate' is considered as the main pathway of superoxide and H<sub>2</sub>O<sub>2</sub> removal in the chloroplast. It is argued that changes in the turnover rate of this cycle and altered redox ratio of dehydroascorbate/ascorbate and/or reduced to oxidized glutathione (GSH/GSSG) would be suitable stress markers in plants (Tausz et al. 2004). Glutathione levels have been reported to fluctuate upon stress exposure and so also the GSH/GSSG redox state which may change to be more oxidized, or reduced, or

remain unchanged. Although lot of work on the response of glutathione to environmental stresses has been done and reviewed (Tausz et al. 2004; Meyer and Hell 2005), yet, a firm conclusion is still awaited. Integration of physiological, biochemical and molecular approaches would allow some deeper insights towards the precise roles and mechanism(s) of GSH involved in resistance to abiotic stresses. In the following sections, we have summarized the efforts made by various research groups involved in the plant GSH research with special reference to the abiotic stress including salt stress, drought, chilling and heavy metal toxicity.

### A Salt Stress

Since salinity is increasing globally at an alarming rate, threatening the agricultural production, research for salinity tolerance of cultivated plants seems to be urgently needed. Molecular studies have shown the up-regulation of cysteine synthesis in *Arabidopsis* in response to salinity (Romero et al. 2001), suggesting a definite role of thiols in salinity resistance. In the roots of salt sensitive species of tomato, decreased activities of the antioxidant enzymes along with the lower content of the antioxidants ascorbate and GSH and their redox states were observed, while the reverse was evident in salt tolerant species (Shalata et al. 2001). A higher GSH content in salt-resistant cultivars as compared to susceptible ones has been reported in rice (Vaidyanathan et al. 2003) and in *Arachis hypogaea* L. (Jain et al. 2002). Transgenic tobacco plants over-expressing GST and GPX exhibited improved seed germination and seedling growth under salt stress associated with several other changes including higher levels of GSH and ascorbate and higher activity of monodehydroascorbate reductase as compared to wild-type seedlings (Roxas et al. 2000). These results indicate that the increased GSH-dependent peroxidase scavenging activity and the associated changes in GSH and ascorbate metabolism lead to reduced oxidative damage in the transgenic plants and contribute to increased salt tolerance. A threefold increase in cysteine and GSH content was observed in wild-type plants of *Brassica napus* exposed to salt stress, whereas, transgenic plants with a high potential to sequester sodium into the vacuoles did not show this effect indicating the presence of a mechanism which is devoid

of glutathione metabolism (Ruiz and Blumwald 2002). High concentrations of glutathione along with high GSH/GSSG redox potential has been suggested to confer better antioxidative protection and might be considered an acclimation against the stress factor (Tausz et al. 2004).

Differences in GSH biosynthesis and its turnover were observed in *Lycopersicon esculentum* and its salt-tolerant wild relative *L. pennellii* (Mittova et al. 2003). The salt-tolerant species was able to increase GSH synthesis and maintain favorable GSH/GSSG redox state within 15 days in response to NaCl, while such a response was lacking in salt sensitive cultivated species. These changes were associated with higher activities of GST and GPX in *L. pennellii* as compared to *L. esculentum* suggesting a definite involvement of GSH-related metabolic pathways in salt resistance in tomato. Higher activity of glutathione reductase in the tolerant cultivar of wheat as compared to its susceptible counterpart was observed under long-term sodium chloride exposure (Sairam et al. 2005) again suggesting that better maintenance of GSH/GSSG ratio confers tolerance against salt stress. ROS-mediated membrane lipid peroxidation in the root of *A. thaliana* was fluorescently visualized in untransformed and GST over-expressing plants. Degree of lipid peroxidation decreased upto 46% in transgenic as compared to wild type plants under 100 mM NaCl stress suggesting that introduction/over-expression of a GST gene may have reduced the amount of ROS thus having a role in tolerance mechanism (Katsuhara et al. 2005). Role of GSH in conferring salt tolerance is being tested in authors' laboratory in tomato. Exogenous application of GSH partially ameliorates harmful effects of salt stress at an early stage as well as at the fruiting stage (Fig. 1; Kumar and Sopory, unpublished). Four days of NaCl treatment to 21-day old tomato plants led to stunted growth; however in the presence of GSH, growth of these plants was observed almost upto the control level (Fig. 1a). Another problem commonly noticed under salt stress is shedding of flowers which resulted in non-fruiting; even a single fruit could not be seen in salt treated plants. However, some healthy fruits were seen when GSH was applied along with the salt treatment (Fig. 1b). The above results are encouraging and further efforts are being made to establish the role of GSH in signaling events including the transcriptional and post-



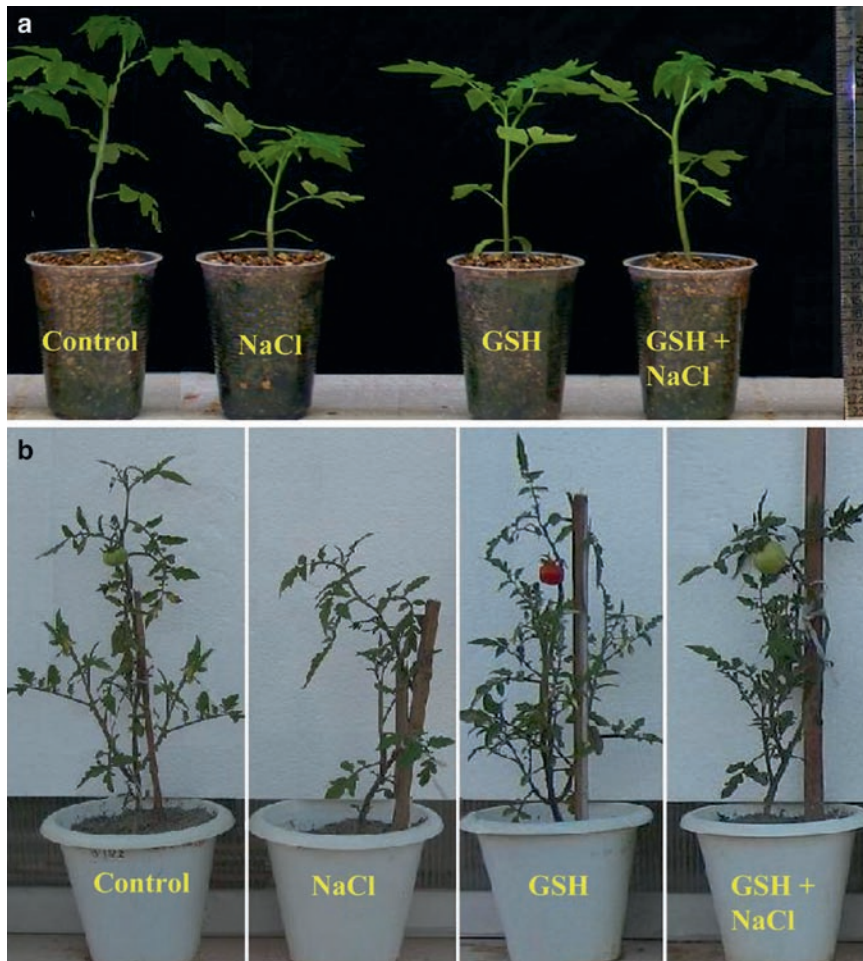

Fig. 1. Salinity stress and reduced glutathione (GSH). Effect of exogenous application of NaCl (200 mM) and/or GSH (2 mM) on tomato plants as seen on (a) growth and (b) fruiting of plants in pot culture. (Kumar, Singla-Pareek and Sopory Unpublished) [See Color Plate 6, Fig. 11]

translational modifications with an emphasis on glutathionylation of target proteins.

A different approach has been suggested by Singla-Pareek et al. (2003) which again showed the involvement of GSH in salt tolerance. Tobacco plants were transformed for glyoxalase pathway by over-expressing two important genes (*glyI* and *glyII*) together. The double transgenic lines always showed a better response than either of the single gene-transformed lines and wild type plants under salinity stress. Comparison of various growth parameters and seed production demonstrated that there is hardly any yield penalty in the double transgenic plants under non-stress conditions and that these plants suffered only 5% loss in total productivity when grown in 200 mM NaCl. These findings established the significance

of GSH as it is involved in glyoxalase pathway and the potential of manipulation of glyoxalase pathway for increased salinity tolerance without affecting yield in crop plants.

GPXs are family of isozymes that utilize GSH to reduce various peroxides including hydrogen peroxide. In recent years, number of GPXs genes have been identified from plant species including rice, cotton, tomato, tobacco and barley. Avsian-Kretchmer et al. (2004) showed induction of *gpx1* by salt and oxidative stress in citrus and concluded that salt induces oxidative stress and produced  $H_2O_2$  in the intercellular space which further participate in signal transduction pathway and, in turn, activates the *gpx1* promoter. These evidences point to a putative signaling role of glutathione system to achieve salt tolerance in crop plants.



## B Water Deficit

Evolutionary control to regulate the water deficit in plant is associated with closure of stomata in order to reduce water loss; however, it also restricts the entry of CO<sub>2</sub> into the chloroplasts. It results in the inhibition of dark reaction and creates the condition of photo-oxidative stress which disrupts normal plant functions in the presence of excess photon energy. Hence, attention is being paid to the role of antioxidants defense in drought resistance including the glutathione metabolism. Glutathione homeostasis and its relationship to protein synthesis during drought and subsequent rehydration have been examined in the drought-tolerant moss, *Tortula ruralis*. During slow development of water deficit, there is a small decrease in total glutathione pool but the amount of GSSG increased and these changes revert back to normal completely upon rehydration of slowly dried moss (Dhindsa 1991). However, a quick but short-term drought treatment increased GSH concentrations and GR activity in wheat leaves (Bartoli et al. 1999), while severe drought caused an oxidation of the glutathione pool in barley leaves (Smirnoff 1993). *Vigna cutjang* seedlings when subjected to water stress resulted in increased glycolate oxidase activity, H<sub>2</sub>O<sub>2</sub> and proline content associated with a decreased catalase activity and ascorbic acid and lowered leaf water potential. Pretreatment with cysteine and GSH conferred resistance and indicated that GSH makes the plant tolerant against water stress by modulating the endogenous levels of H<sub>2</sub>O<sub>2</sub> and ascorbic acid in stressed tissue (Mukherjee and Choudhuri 1983). In pine trees, mild drought resulted in a slight decrease in the GSH/GSSG ratio only for 2 days suggesting existence of a possible signal cascade for longer-term acclimation processes (Tausz et al. 2001).

Comparative studies between susceptible and resistant intra- or inter-specific crop cultivars have also emphasized on the significance of GSH. Two wheat cultivars with varying drought tolerance when subjected to water stress for 1 month showed a decline in total GSH concentrations and elevation in GSH/GSSG ratio (Loggini et al. 1999). Susceptible cultivar showed increased activities of GSH-related enzymes as compared to the tolerant one. After rehydration, the GSH/GSSG redox state recovered quickly, but GSH concentrations remained lower.

An important point that emerged from the study is that the resistant cultivar did not show increase in enzyme activities because it maintained higher constitutive levels enough to resist the stress factor, whereas in the susceptible cultivar defense mechanism is induced to cope the stress factor. It was also found that total GSH concentrations in flag leaves of wheat increased upon drought stress to a water potential level below -3.0 MPa in the susceptible cultivar and not in resistant one (Herbinger et al. 2002). In contrast to these observations, Lascano et al. (2001) found no significant variations among four different wheat cultivars after 1 month of drought exposure in the field; however, total glutathione concentrations elevated significantly in the two most drought-resistant cultivars during re-watering. Authors therefore suggesting that responsiveness of GSH synthesis upon osmotic stress can serve as a screening criterion for the selection of cultivars (Lascano et al. 2001). The reasons for differences in results could be due to the magnitude of stress which never seems to be exactly equal in the studies on drought. Also in different situations, alternative protective systems could play important roles and could share the oxidative load. Drought-induced increase in zeaxanthin, which is involved in dissipation of excess photon energy (Herbinger et al. 2002) and quenching of energy via photorespiration (Noctor et al. 2002) has been demonstrated to be an alternative mode of oxidative load sharing. Thus, depending upon the existence and the degree of operation of these alternative pathways, responsiveness of the glutathione system may vary from species to species and even within species. Another factor to account for the differences when comparing different species is the responsiveness of stomata which may vary in species. This contributes to a significant variation in inhibiting dark reactions of photosynthesis. Similarly, the light harvesting capacity of different crop species should be taken into account which otherwise may be a source of variation in species response.

## C Low Temperature

Crop plants usually face problem of low temperature especially at high altitudes. This low temperature stress in association with high irradiance favors photo-oxidative stress in plants.

GSH is reported to be involved in the protection of plants from low temperature. Total glutathione level increased in white pine (Anderson et al. 1992) and alpine plants (Wildi and Lutz 1996) when exposed to low temperature and was ascribed to the role of GSH as an antioxidant to protect against low temperature-induced injuries. A positive correlation was observed between chilling tolerance of maize cultivars and GSH concentrations along with GR activities under stress conditions (Leipner et al. 1999). Chilling susceptible cucumber seedlings when exposed to low temperature (5°C) at irradiance of 1,000 mmol m<sup>-2</sup>s<sup>-1</sup>, total glutathione levels were depleted immediately and GSSG became the predominant form after 10 h of exposure, while such changes were not evident in the chilling tolerant cultivars (Wise and Naylor 1987). Total glutathione levels were depleted in *L. esculentum* drastically than wild genotype *L. hirsutum* after chilling treatment at 2°C for 72 h (Walker and McKersie 1993). At low, nonfreezing, temperatures the higher GSH content and GSH/GSSG ratio in tolerant genotypes of sorghum (Badiani et al. 1997) as compared to their sensitive counterparts were observed indicating the role of GSH in chilling tolerance. Low temperature treatment increased the GR activity in crop species like maize and is attributed to the fact that GR reduced the oxidized GSSG to GSH thus improve GSH/GSSG ratio and maintain the redox potential in favorable state (Pinhero et al. 1997). Poplar plants with high foliar GSH pools and also over-expressing chloroplast targeted GR had increased tolerance against low temperature-induced photoinhibition (Foyer et al. 1995). A different approach was used by Kocsy et al. (2001) where GSH levels were increased in a chilling-sensitive maize genotype using herbicide safeners, and decreased by the application of BSO (inhibitor of GSH synthesis) and suggested that genetic or chemical manipulation of GSH level may contribute to chilling tolerance in maize seedling at least in controlled conditions. In contrast, chlorosis or necrosis in tobacco plants over-expressing  $\gamma$ -ECS and containing increased GSH levels was observed and such injuries were ascribed as a result of oxidation of the  $\gamma$  EC pool (Creissen et al. 1999). Exogenous application of GSH could not improve chilling tolerance of rice leaves in the short-term (2 h) treatment which experienced even stronger

photoinhibition. This situation was explained by the authors as the inhibition of photo-protective xanthophyll cycle by the GSH (Xu et al. 2000).

Correlation between chilling stress and free radical scavenging and their relationship with the process of acclimation has been in focus of the molecular biologists. The promoter of cytosolic CuZnSOD gene was isolated from *Nicotiana glauca* and fused to the GUS reporter gene and expression was studied in transgenic plants (H rouart et al. 1993). The expression of the CuZnSOD gene is induced by sulfhydryl compounds such as GSH, cysteine and DTT, whereas the GSSG and oxidized cysteine had no effect. A dual role of GSH has been suggested here, as GSH directly acts as an antioxidant and simultaneously activates the CuZnSOD gene during oxidative stress. Genetic manipulation leading to an increase in the activities of glutathione-ascorbate cycle enzymes in cotton plants resulted in better resistance to chilling-related photo-oxidative stress and such improved resistance was in fact due to higher efficiency of the ascorbate-glutathione cycle and ‘in turn’ the efficient detoxification of ROS (Payton et al. 2001). However, manipulations of single GSH-related components of the antioxidant systems may not necessarily improve the resistance of plants, but may even lead to increased susceptibility due to interactions with other components of the defense system (Creissen et al. 1999). Thus, careful consideration of the whole system and integration of the physiological parameters like  $F_v/F_m$  ratio along with the possible interactions with other metabolic pathways seem to be the ultimate need.

#### D Ozone Toxicity

Ozone is considered as a predominant phytotoxic environmental stress factor which alters the expression of several genes including those encoding for proteins involved in antioxidant defense mechanisms. Ozone disturbs glutathione homeostasis and triggers a number of changes including cytosolic Ca<sup>2+</sup> level (Clayton et al. 1999). In *Arabidopsis* seedlings, these changes were associated with the alterations in cellular redox state contributed by GSH and ascorbate rather than their total concentration (Evans et al. 2005). However, ozone induced changes in cytosolic Ca<sup>2+</sup> is a very fast response and appears

within the first minute of the treatment, whereas other major changes in the redox state of the glutathione pool appear later. Thus, the delayed changes in the cellular redox status can be used to modify signaling or metabolic processes further downstream to the  $\text{Ca}^{2+}$  response. It was found that MAPK activity was induced by necrosis-inducing concentrations of ozone (Samuel et al. 2000) and may also involve the  $\text{H}_2\text{O}_2$ -induced signaling as it is required for successful transmission of redox cues after pathogen attack (Grant et al. 2000). Full activation of MAPKs 3 and 6 requires the serine/threonine protein kinase OXI1 which is involved in ROS sensing and can be induced by  $\text{H}_2\text{O}_2$ -generating stimuli (Rentel et al. 2004). Earlier, OXI1 has been shown to be involved in ROS mediated basal resistance of *Arabidopsis* to *Peronospora parasitica* and in root hairs growth and formation of  $\text{H}_2\text{O}_2$  (Foreman et al. 2003). Thus, OXI1 seems to be an important component of the signal transduction pathway linking oxidative burst signals to diverse downstream responses (Rentel et al. 2004).

### E Heavy Metal Toxicity

Glutathione plays an indispensable role in protecting plants from heavy metals toxicity. Phytochelatin synthase (PCS) catalyzes synthesis of phytochelatin (PC) from its immediate precursor 'GSH' in the presence of metal ions. PCs play a pivotal role in sequestering heavy metal ions by binding them and transporting them into the vacuole and thus avoid toxic effects on metabolism. Grill et al. (1989) discovered and characterized PCS protein from *Silene cucubalus* cell suspension cultures that catalyzes the transfer of the  $\gamma$ -glutamylcysteine dipeptide moiety of GSH to an acceptor GSH molecule or to a growing chain of  $[\text{Glu}(-\text{Cys})]_n$ -Gly oligomers, thus synthesizing PCs. *Arabidopsis* plants treated with cadmium or copper showed increased transcription of the PCS genes and also the genes encoded for  $\gamma$ -ECS and GSH-S, as well as GR and such a response was very specific for those metals whose sequestration is mediated through PCs, while other toxic and non-toxic metals did not alter mRNA levels of PCS (Xiang and Oliver 1998). PCS has also been found to hydrolyze GSH/GS-conjugated xenobiotics. As a structural variation, in the cyanobacterium *Nostoc*, the enzyme (NsPCS) contains only

the catalytic domain of the eukaryotic PCS and act as a GSH hydrolase and secondly as a peptide ligase (Denis et al. 2005).

Excess of toxic metal ions in soil results in stunted plant growth, root damage, chlorosis and necrosis, and also affect key physiological attributes of crop plants. Since last decade, ample attention has been paid to *Brassica juncea* as a heavy metal-accumulator with a high biomass production, which makes it a suitable plant for phytoremediation strategies. Efforts have also been made to increase biosynthesis of GSH in *B. juncea* and transgenic approaches have shown that in this species ectopic expression  $\gamma$ -ECS enzyme resulted in higher Cd sequestration (Zhu et al. 1999). A cDNA namely *BjPCS1* was isolated and cloned from *B. juncea* and its CLUSTAL analysis revealed a close relationship with PCS proteins from *A. thaliana* and *Thlaspi caerulescens*. Expression of *BjPCS1* in *E. coli* and biochemical characterization of recombinant protein showed PCS activity in vitro that was activated by 50  $\mu\text{M}$  Cu and 200  $\mu\text{M}$  Cd upto a similar extent (Heiss et al. 2003). Further, immunoblot analysis directed against recombinant BjPCS1 showed constitutive PCS expression during plant development and the expression was higher in the roots, internodes and petioles in comparison with the leaf tissue. Another cDNA clone *LjPCS1* encoding a protein with PCS activity was isolated from lotus (*Lotus japonicus*) showing high homology to homophytochelatin synthase (hPCS) of *Glycine max* (Loscos et al. 2006).

The transgenic tobacco plants overexpressing glyoxalase I and II (glyI and glyII) flowered and set viable seeds successfully in 5 mM  $\text{ZnCl}_2$  without any yield loss (Singla-Pareek et al. 2006). Zn accumulation was highest in roots while it was negligible in transgenic seeds. Increase in the level of PCs and maintenance of glutathione homeostasis in transgenic plants during exposure to excess zinc are the possible mechanisms for the observed tolerance. On the basis of two strategies namely phytochelation and glyoxalase engineering, GSH emerged out as one of the key molecule. As the synthesis of PCs invariably required GSH, its direct role can be easily speculated in heavy metal sequestration into the vacuole thus providing an avoidance mechanism of heavy metal toxicity. Secondly, being a substrate for glyI enzyme, GSH can also play critical role in detoxification

of methylglyoxal which was found to be synthesized when plants are subjected to various abiotic stresses including heavy metal toxicity.

## VI Protein Oxidation Under Abiotic Stresses

Oxidative cell environment favours oxidation of thioether bond of methionine and converts it into methionine sulfoxide which can be reduced back by the action of protein methionine sulfoxide reductase (PMSR) thus eliminating the oxidative damage. PMSR is involved in protection against oxidative stress and its over-expression in *Arabidopsis* showed better stress tolerance (Bechtold et al. 2004). It is known that methionine residues within protein undergo oxidation in the presence of excess oxidative load. These oxidized methionine residues thus can lead to certain changes in protein characteristics resulting in stress responses. Plants have developed strategies to cope up with these unfavorable conditions by keeping the methionine residues in the reduced state. PMSR along with thioredoxin and thioredoxin reductase plays a crucial role in maintaining the redox balance. Fig. 2 summarizes the steps involved in oxidation of methionine residues of proteins and their reduction back to native state.

Like methionine, cysteine residues within proteins can also undergo oxidation. Peroxiredoxins (Prxs), the functionally specialized proteins, are abundant but less efficient peroxidases located in distinct cell compartments including the chloroplasts and mitochondria. These proteins contain a cysteinyl residue in catalytic center that reduces diverse peroxides and is regenerated via intramolecular or intermolecular thiol-disulfide reactions and finally by electron donors such as thioredoxins, sulphiredoxin and glutaredoxins. Peroxiredoxins show a complex regulation by endogenous and environmental stimuli at both the transcript and protein levels. In addition to their role in antioxidant defense, in photosynthesis, respiration and stress response, they may also be involved in modulating redox signaling during development and adaptation (Dietz et al. 2006). The mechanism of oxidation of protein bound cysteine residues occurs via two main pathways in plants. One is common to most of the proteins while the other appears to be

specific for Prxs. Fig. 3 illustrates both the pathways simultaneously.

Recently, Rey et al. (2007) suggested that 2-cysteine peroxiredoxins (2-Cys-Prxs) are antioxidant proteins involved in the reduction of peroxides through a thiol-based mechanism. In plants, 2-Cys-Prxs constitute the most abundant Prxs and are located in chloroplasts. During catalysis, these proteins are inactivated by the substrate-dependent oxidation of the catalytic cysteine to the sulfinic acid (-SO<sub>2</sub>H) form, and are reactivated by reduction by sulphiredoxin (Srx), an enzyme recently identified in yeast and mammalian cells. A unique Srx gene has been characterized in *A. thaliana* (*AtSrx*) and analysis of the *AtSrx* knockout (*AtSrx*-) mutant lines revealed that substrate-mediated inactivation of plant 2-Cys-Prxs was reversed by Srx and suggested that the 2-Cys-Prx redox status and sulphiredoxin are part of a signaling mechanism participating in plant responses to oxidative stress (Rey et al. 2007). Cysteine sulfinic acid cannot be reduced back to cysteine sulfenic acid in proteins other than peroxiredoxins because the sulphiredoxin is specific only for peroxiredoxins (Woo et al. 2005). Protein degradation seems to be certain for proteins other than peroxiredoxins, which leads to formation of cysteine sulfinic acid or to free cysteic acid and metabolized further in order to regenerate cysteine for new protein synthesis. However, situation can be modified by the diversion of the normal pathway of protein oxidation at the very first step of oxidation (cysteine sulfenic acid) as illustrated in the Fig. 3 and will be emphasized in the succeeding section. A functional strategy to divert the protein oxidation pathway in favorable direction needs to be worked out and if it is so, then GSH again is expected to emerge as a key player.

## VII Glutathione as Signaling Molecule and Role of Glutaredoxins

GSH and H<sub>2</sub>O<sub>2</sub> alone or in combination may act as an intercellular and systemic signaling system to achieve tolerance to environmental stresses (Foyer et al. 1997; Morita et al. 1999). The significance of GSH is further strengthened by its possible involvement in redox signaling processes including protein glutathionylation and impact



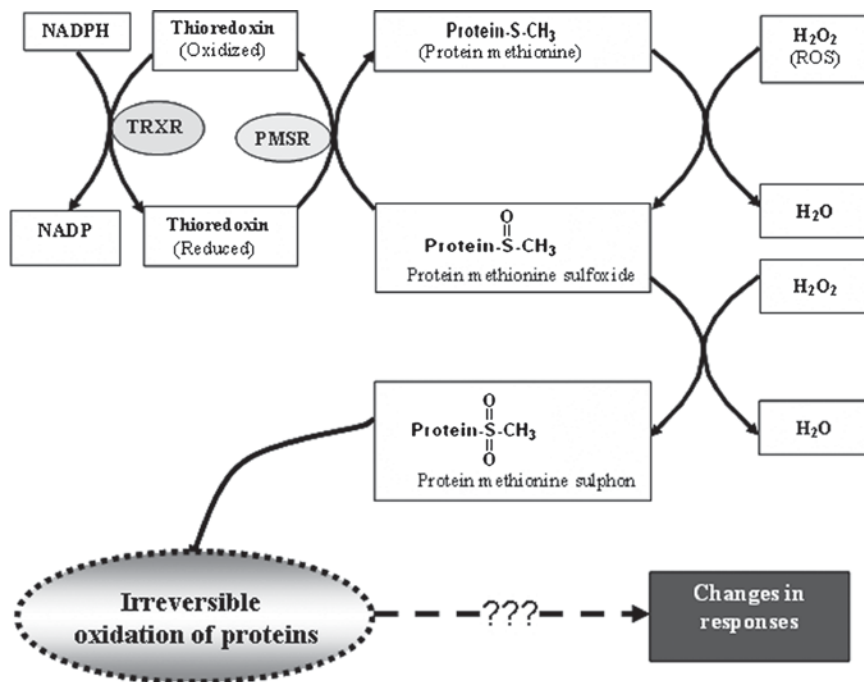

Fig. 2. Mechanism of oxidation of protein-bound methionine residues under oxidative conditions and steps involved in the reduction of the oxidized methionine in plant cells (Enzymes: Protein methionine sulfoxide reductase [PMSR]; Thioredoxin reductase [TRXR]).

over transcription factors (Meyer and Hell 2005 and references therein). Adverse environmental conditions disturb the cellular redox homeostasis and influence transcription factors and expression of genes involved in the protection of plants against abiotic stresses. The whole sequence of events involving the role of GSH is summarized in Fig. 4.

The first oxidation step forming cysteine sulphenic acid (Cys-SOH) is reversible and can be explored for redox signaling purpose while further oxidation to cysteine sulfinic acid (Cys-SO<sub>2</sub>H) and cysteine sulfonic acid (Cys-SO<sub>3</sub>H) are irreversible steps and make the protein prone to oxidative damage. GSH status mediates the transmission of oxidative stress signals regulating the oxidative status of the cells. In this process specific proteins such as glutaredoxins (GRXs) are expected to play an important role. It has been suggested that GSSG-driven or enzyme-catalyzed 'protein glutathionylation' can be reversed by glutaredoxins (Lemaire 2004). GRXs which are small thermo-stable oxidoreductases play key roles in maintaining the cellular redox balance (Gelhaye et al. 2005). GRXs can reduce protein sulfur by

the formation of mixed disulfides between GSH and proteins by a dithiol mechanism. Like thioredoxins, GRXs may operate as dithiol reductants and thus may be involved in other cellular functions such as formation of deoxyribonucleotides for DNA synthesis (by reducing the essential enzyme ribonucleotide reductase), the generation of reduced sulfur (via 3'-phosphoadenylylsulfate reductase), signal transduction and the defense against oxidative stress (Fernandes and Holmgren 2004). Genomic analysis of plant GRXs revealed three major classes of GRXs, the CPYP type, the CGFS type and the CC type harboring a CCMS/C motif which seems to be specific to higher plants (Lemaire 2004). Isolation and characterization of gene *ROXY1* (a member of the CC type group) was done by Xing et al. (2005) and it was suggested that *ROXY1* required for normal petal development in *A. thaliana*. Action of this gene seems to be highly localized in the second whorl of the flower indicating the involvement of GRXs in plants. Higher abundance and diversity of GRXs in *Populus trichocarpa* (36 genes) compared to *A. thaliana* (31 genes) and *O. sativa* (27 genes) suggest species specific roles of GRXs.

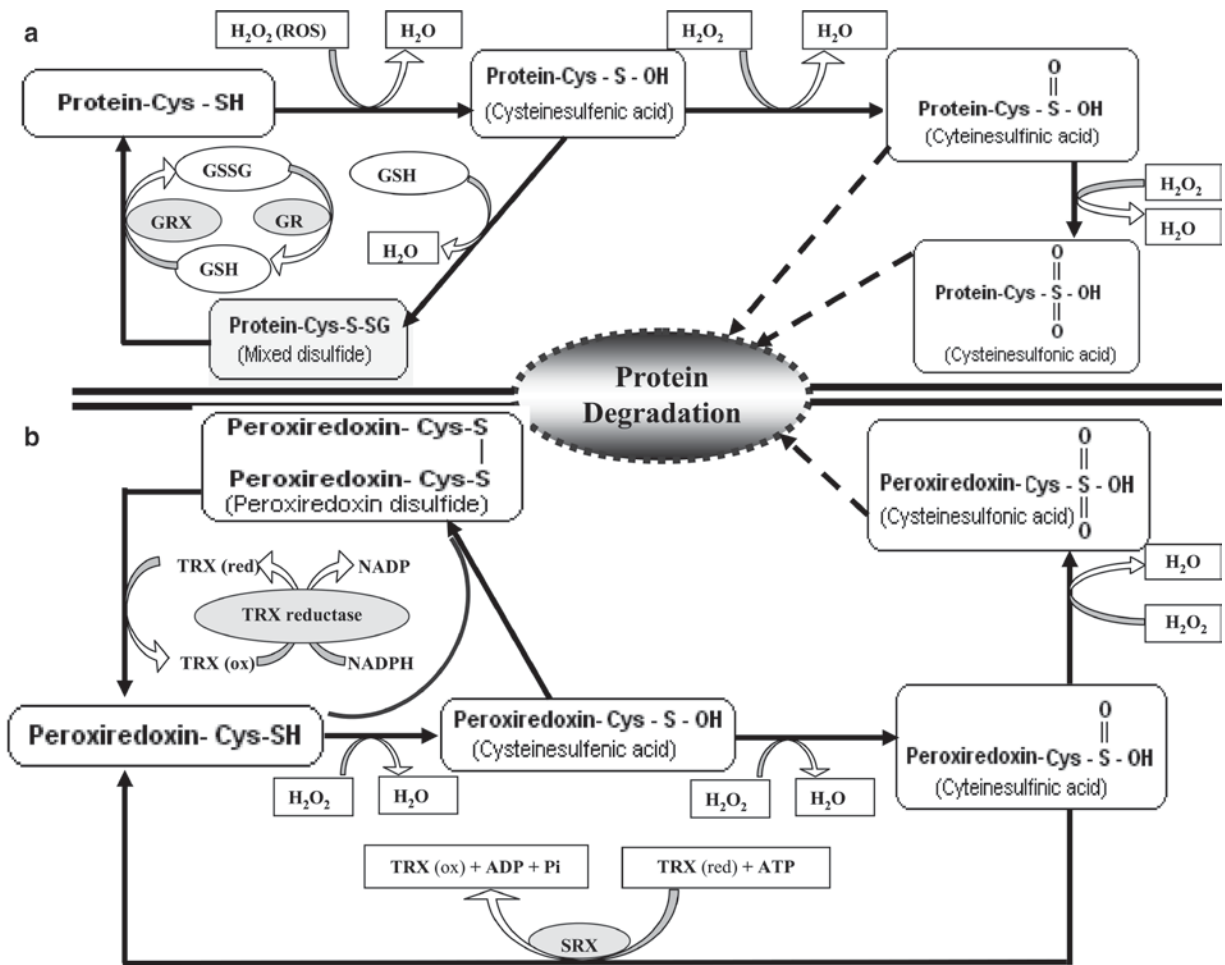

Fig. 3. Mechanism of oxidation of cysteine-SH under oxidative conditions and possible reactions involved in reduction of the oxidized cysteine in plant cells (a) oxidation of cysteine-SH groups in proteins; (b) oxidation of cysteine-SH groups in peroxiredoxins (glutaredoxin [GRX]; glutathione reductase [GR]; thioredoxin [TRX]; sulphiredoxin [SRX]).

Participation of these proteins in the electron transfer in biochemical reactions is independent of the  $NAD(P)^+/NAD(P)H$  system. Such a function of GRXs has been described for the oxidative degradation of dihydroliipoamide in *E. coli* (Porras et al. 2002) in which electrons are being transferred to GSSG as the final acceptor. GRXs have been reported to be localized in almost all the functional cell compartments *viz.* cytosol, endoplasmic reticulum, mitochondria and chloroplasts suggesting the involvement of GRXs in important cell functions (Meyer and Hell 2005). Additional putative functions can be assigned for plant GRXs based on their targets and in the light

of existence of hybrid proteins containing GRX modules in their N- or C-terminal part (Rouhier et al. 2004). GSH-dependent dehydroascorbate reductase and a type II peroxidase like glutathione peroxidase have been suggested to be target proteins of the GRXs in plants which further signify the potential of these proteins in detoxification of ROS in plants (Rouhier et al. 2004). To unravel the plant GRXs completely, some intensive and elaborative work needs to be done and available GRX mutants may be a good starting platform to get detailed and specific identification of specific cellular functions in plants especially related to environmental stress tolerance.

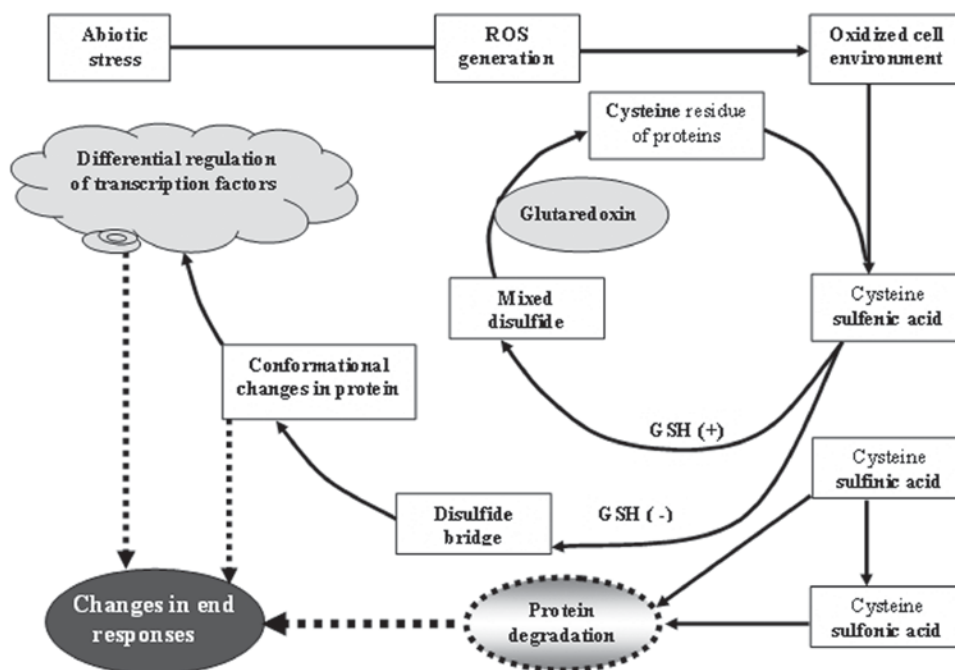

Fig. 4. A line diagram showing the sequence of events during protein oxidation and role of GSH in prevention of protein oxidation.

## VIII Crosstalk and Interaction with Other Biomolecules

Increasing evidences suggest that redox based reactions are involved in the basic metabolic pathways that convert and distribute energy for growth and maintenance. Under adverse conditions plant cells can decipher signals from the redox changes and accordingly regulate gene expression and functions. GSH is an important biomolecule that contributes to a large extent to the cellular redox status. Thus attention has been paid to GSH and its interaction with other components. Utilization of NADPH for the reduction of GSSG in GR driven reaction became more important under environmental stress conditions especially when plants are in a state of excess energy. Interaction between NADP, GSH and protein thiol/disulphide status at regulatory level can be seen in chloroplast and possibly in other cellular compartments also. When light is abundant, increase in  $[NADPH]/[NADP^+]$  results in the reduction of disulphide via the ferredoxin-thioredoxin system which bring back the active state (removal of disulphide bridge) of metabolic enzymes that

use NADPH, as well as  $NADP^+$ -malate dehydrogenase involved in exporting NADPH-reducing equivalents to the cytosol. On the other hand, absence of light creates more oxidizing stromal environment resulting in down regulation of the above mentioned enzymes and generation of NADPH by carbohydrate oxidation (Scheibe et al. 2005). In order to achieve a redox mediated control over metabolic pathways, a dynamic redox exchange between different compartments might exist in plant cells. Several shuttle mechanisms for exchange of NAD(H) or NADP(H) have been suggested (Scheibe et al. 2005). Exchange of ascorbate-reducing equivalents may occur at tonoplast and plasma membrane involving monodehydroascorbate reduction by cytochrome b561 (Preger et al. 2004). Such proteins are expected to play an important role in the regulation of the apoplasmic redox state by co-operation of plasma membrane-bound monodehydroascorbate reductase and ascorbate/monodehydroascorbate/dehydroascorbate exchangers (Berczi and Moller 2000; Pignocchi and Foyer 2003).

Thiol-disulphide exchange is one of the important mechanisms involved in sensing redox

status of cells. Several thioredoxin-interacting proteins have been identified by proteomic studies (Buchanan and Balmer 2005). Chloroplastic thioredoxin system uses ferredoxin in redox exchange reactions, while cytosolic and mitochondrial thioredoxins are linked to NADPH (Buchanan and Balmer 2005). The exact nature, extent and physiological impact of the redox regulatory mechanism and contribution in environmental stress tolerance in plants are still far from completion in vivo and at whole plant level.

Specific proteins in plants can undergo post-translational modification in response to cellular redox changes. Protein oxidation, S-glutathionylation and S-nitrosylation are different post-translational modifications observed in plants under stress conditions (Ito et al. 2003; Dixon et al. 2005). Among these, glutathionylation of proteins has been in focus recently due to its involvement in ROS-catalyzed modification of the cysteine thiol by incorporation of a glutathione moiety (Fig. 2). Protein glutathionylation was studied in *Arabidopsis* in details using 2-D gel electrophoresis and MALDITOF mass spectrometry (Dixon et al. 2005). A total of 79 polypeptides were identified that underwent direct thiolation or making complex with thiolated polypeptides. The mechanism of thiolation of dehydroascorbate reductase (*AtDHAR1*), zeta class GST (*AtGSTZ1*), nitrilase (*AtNit1*), alcohol dehydrogenase (*AtADH1*) and methionine synthase (*AtMetS*) was studied using the respective purified recombinant proteins and it was found that *AtDHAR1*, *AtGSTZ1* and *AtNit1* underwent direct glutathionylation with GSSG-biotin through modification of active site cysteine residues. However, such a direct modulation could not be observed in case of *AtADH1* and *AtMetS* which required the presence of unidentified *Arabidopsis* proteins. Post-translational modification of proteins by GSH requires involvement of GRXs or similar proteins. Glutathionylation appears to affect the activity of chloroplastic thioredoxin (TRX f) and other chloroplastic enzymes and thus constitute a regulatory mechanism of photosynthetic metabolism under oxidative stress in plants (Lemaire et al. 2007; Hisabori et al. 2007). Glutathionylation of TRX f activates target enzymes like fructose-1, 6-bisphosphatase and glyceraldehyde-3-phosphate dehydrogenase (Michelet et al. 2005). If glutathionylation of TRX f happens to

be dependent on GSSG in vivo, then there must be a definite crosstalk in different signaling cascades. Lower GSH/GSSG in chloroplast inhibits the use of NADPH by thioredoxin-mediated pathways, thus increasing the availability of NADPH for enzymes such as GR. In addition, two Calvin cycle enzymes (aldolase and triose phosphate isomerase) have been found to be targets for glutathionylation (Ito et al. 2003). Despite the evidences available, further work is required to elucidate the importance of protein glutathionylation in redox signaling processes operating in plants.

Calcium is involved in most of the cellular signaling processes and interacts with ROS through CaM (Evans et al. 2005). Some important clues can be extracted from observations like modulation of K<sup>+</sup>-channel activity in oocytes (Ciorba et al. 1997) and activity of Ca<sup>2+</sup> pumps in human cells (Gao et al. 1998) by ROS. CaM has a definite role in Ca<sup>2+</sup> dependent signaling as evident from numerous studies. Oxidation of methionine and cysteine residues within CaM may be an important link between ROS- and Ca<sup>2+</sup>-signaling and thus involvement of GSH (Meyer and Hell 2005 and references therein). However, such a mechanism is yet to be investigated in plants. GSH may participate in early signal transduction events by activating Ca<sup>2+</sup>-dependent protein kinases and function in the integration of multiple abiotic and biotic stimuli (Gomez et al. 2004). Analysis of transcript of the *rax-1* mutant showed that GSH deficiency was associated with decreased expression of vacuolar CAX1-like Ca<sup>2+</sup>/H<sup>+</sup> antiporter (Ball et al. 2004) which further interact with several protein partners including CXIP1, a redox protein that is a type of glutaredoxins (Cheng and Hirschi 2003; Lemaire 2004). In a pioneer study on barley, vacuolar ATPase activity underwent inactivation by H<sub>2</sub>O<sub>2</sub> and can be reactivated by GSH (Tavakoli et al. 2001). These results support the hypothesis that tuning of vacuolar ATPase activity can be mediated by redox control depending on the metabolic requirements. Functionally, interactions between Ca<sup>2+</sup> and ROS signaling systems can be both stimulatory and inhibitory, depending on the type of target proteins, the ROS species, the dose, duration of exposure, and the cell contexts (Yan et al. 2006). The above evidences together, indicate a possible interplay among various signaling pathways and regulation of the metabolic events seems to be under tight



control of more than one controlling pathways depending upon the cellular and environmental conditions.

## IX Conclusions and Perspectives

Oxidative stress is associated with all the environmental stresses in plants and poses a serious threat by disturbing their normal growth, development and physiology. Glutathione plays important roles in defense against oxidative stress and remains in focus for engineering to enhance stress resistance in plant. Available literature suggests that glutathione is an important contributor to the intracellular redox potential and influences setting thresholds for cellular signaling. Since oxidant scavenging pathway is present in different cellular components including peroxisomes, chloroplasts, mitochondria and cytoplasm, it is likely that a dynamic mechanism exist which facilitate GSH transport across these compartments. Interaction of GSH with other signaling cascade seems to exist and such an interaction possibly involves redox mediated signal transduction. Oxidation of thiol groups in proteins especially the methionine and cysteine residues suggests that they are open and easy target of oxidative attack. The cellular GSH-GSSG redox buffer provides homeostasis by maintaining the redox state of thiol compounds thus avoiding their unnecessary oxidation and keeping them in the reduced state. Post-translational modification of proteins by the process of glutathionylation prevents proteins from oxidation. The reversible formation of a mixed disulfide between glutathione and sulfur containing amino acid residues on the target proteins brings about conformational changes which can changes then trigger the signaling cascade leading to the altered responses. Glutaredoxins catalyze the reverse reaction of glutathionylation which is known as deglutathionylation, thus the operation of the glutathionylation/deglutathionylation system provide a safeguard to the protein oxidation and keeping them in active state. However, during this process, several other cellular changes take place depending on the situation; these initiate other signaling cascades which ultimately decide the fate of cell/tissue under question and such changes need to be investigated at a higher scale of specificity to obtain a deeper insight into the

problem. More work needs to be done to unravel the entire scenario and to pinpoint the precise role of glutathione in redox mediated signaling and its crosstalk with other pathways especially under environmental stresses in plants.

## Acknowledgements

The research in the laboratory of SKS and SLS-P is supported by ICGEB, Department of Biotechnology (DBT), Department of Science and Technology (DST), Government of India. Grants under the SBIRI program, and the 'Innovative Young Biotechnologist Award (IYBA)' from DBT are gratefully acknowledged by SLS-P. BK acknowledges grant from DST under the 'Fast-Track Young Scientist' scheme.

## References

- Anderson JV, Chevone BI, Hess JL (1992) Seasonal variation in the antioxidant system of eastern white pine needles. *Plant Physiol* 98:501–508
- Avsian-Kretchmer O, Gueta-Dahan Y, Lev-Yadun S, Gollop R, Ben-Hayyim G (2004) The salt-stress signal transduction pathway that activates the *gpx1* promoter is mediated by intracellular H<sub>2</sub>O<sub>2</sub>, different from the pathway induced by extracellular H<sub>2</sub>O<sub>2</sub>. *Plant Physiol* 135:1685–1696
- Badiani M, Paolacci AR, Fusari A, D'Ovidio R, Scandalios JG, Porceddu E, Sermanni GG (1997) Non-optimal growth temperatures and antioxidants in the leaves of *Sorghum bicolor* (L.) Moench: II. Short-term acclimation. *J Plant Physiol* 151:409–421
- Ball L, Accotto G, Bechtold U, Creissen G, Funck D, Jimenez A, Kular B, Leyland N, Mejia-Carranza J, Reynolds H, Karpinski S, Mullineaux PM (2004) Evidence for a direct link between glutathione biosynthesis and stress defense gene expression in *Arabidopsis*. *Plant Cell* 16:2448–2462
- Bartoli CG, Simontacchi M, Tambussi E, Beltrano J, Montaldi E, Puntarulo S (1999) Drought and watering-dependent oxidative stress: effect on antioxidant content in *Triticum aestivum* L. leaves. *J Exp Bot* 50:375–383
- Bechtold U, Murphy DJ, Mullineaux PM (2004) *Arabidopsis* peptide methionine sulfoxide reductase2 prevents cellular oxidative damage in long nights. *Plant Cell* 16:908–919
- Berczi A, Moller IM (2000) Redox enzymes in the plant plasma membrane and their possible roles. *Plant Cell Environ* 23:1287–1302
- Bergmann L, Rennenberg H (1993) Glutathione metabolism in plants. In: De Kok LJ, Stulen I, Rennenberg H, Brunold C, Rausser WE (eds) Sulfur nutrition and assimilation in

- higher plants: regulatory, agricultural and environmental aspects. SPB Academic Publishing, The Hague, The Netherlands, pp 102–123
- Buchanan BB, Balmer Y (2005) Redox regulation: a broadening horizon. *Annu Rev Plant Biol* 56:187–220
- Cagnac O, Bourbonloux A, Chakrabarty D, Zhang MY, Delrot S (2004) AtOPT6 transports glutathione derivatives and is induced by primisulfuron. *Plant Physiol* 135:1378–1387
- Cheng NH, Hirschi KD (2003) Cloning and characterization of CXIP1, a novel PICOT domain-containing *Arabidopsis* protein that associates with CAX1. *J Biol Chem* 278:6503–6509
- Ciorba MA, Heinemann SH, Weissbach H, Brot N, Hoshi T (1997) Modulation of potassium channel function by methionine oxidation and reduction. *Proc Natl Acad Sci USA* 94:9932–9937
- Clayton H, Knight MR, Knight H, McAinsh MR, Hetherington AM (1999) Dissection of the ozone induced calcium signature. *Plant J* 17:575–579
- Creissen G, Firmin J, Fryer M, Kular B, Leyland N, Reynolds H, Pastori G, Wellburn F, Baker N, Wellburn A, Mullineaux P (1999) Elevated glutathione biosynthetic capacity in the chloroplasts of transgenic tobacco plants paradoxically causes increased oxidative stress. *Plant Cell* 11:1277–1292
- Denis V, Pascal A, David P (2005) A papain-like enzyme at work: native and acyl-enzyme intermediate structures in phytochelatin synthesis. *Proc Natl Acad Sci USA* 102:18848–18853
- Dhindsa R (1991) Drought stress, enzymes of glutathione metabolism, oxidation injury and protein synthesis in *Tortula ruralis*. *Plant Physiol* 95:648–651
- Dietz KJ, Jacob S, Oelze ML, Laxa M, Tognetti V, Miranda SMN, Baier M, Finkemeier I (2006) The function of peroxiredoxins in plant organelle redox metabolism. *J Exp Bot* 57:1697–1709
- Dionisio-Sese ML, Tobita S (1998) Antioxidant responses of rice seedlings to salinity stress. *Plant Sci* 135:1–9
- Dixon DP, Skipsey M, Grundy NM, Edwards R (2005) Stress-induced protein S-glutathionylation in *Arabidopsis*. *Plant Physiol* 138:2233–2244
- Edwards R, Dixon D, Walbot V (2000) Plant glutathione S-transferases: enzymes with multiple functions in sickness and in health. *Trends Plant Sci* 5:193–198
- Evans NH, McAinsh MR, Hetherington AM, Knight MR (2005) ROS perception in *Arabidopsis thaliana*: the ozone-induced calcium response. *Plant J* 41:615–626
- Fernandes A, Holmgren A (2004) Glutaredoxins: glutathione-dependent redox enzymes with functions far beyond a simple thioredoxin backup system. *Antioxid Redox Signal* 6:63–74
- Foreman J, Demidchik V, Bothwell JH, Mylona P, Miedema H, Torres MA, Linstead P, Costa S, Brownlee C, Jones JD, Davies JM, Dolan L (2003) Reactive oxygen species produced by NADPH oxidase regulate plant cell growth. *Nature* 27:442–446
- Foyer CH, Souriau N, Perret S, Lelandais M, Kunert KJ, Pruvost C, Jouanin L (1995) Overexpression of glutathione reductase but not glutathione synthetase leads to increases in antioxidant capacity and resistance to photoinhibition in poplar trees. *Plant Physiol* 109:1047–1057
- Foyer CH, Lopez-Delgado H, Dat JF, Scott IM (1997) Hydrogen peroxide and glutathione associated mechanisms of acclimatory stress tolerance and signaling. *Physiol Plant* 100:241–254
- Gao J, Yin DH, Yao YH, Sun HY, Qin ZH, Schoneich C, Williams TD, Squier TC (1998) Loss of conformational stability in CaM upon methionine oxidation. *Biophys J* 74:1115–1134
- Gelhaye E, Rouhier N, Navrot N, Jacquot J (2005) The plant thioredoxin system. *Cell Mol Life Sci* 62:24–35
- Gomez L, Vanacker H, Buchner P, Noctor G, Foyer CH (2004) The intercellular distribution of glutathione synthesis and its response to chilling in maize. *Plant Physiol* 134:1662–1671
- Grant JJ, Yun BY, Loake GJ (2000) Oxidative burst and cognate redox signaling reported by luciferase imaging: Identification of a redox signaling network that functions independently of ethylene, SA and Me-JA but is dependent on MAPKK activity. *Plant J* 24:569–582
- Grill ES, Loeffler E, Winnacker L, Zenk MH (1989) Phytochelatin, the heavy-metal-binding peptides of plants, are synthesized from glutathione by a specific  $\gamma$ -glutamylcysteine dipeptide transpeptidase (phytochelatin synthase). *Proc Natl Acad Sci USA* 86:6838–6842
- Hanson GT, Aggeler R, Oglesbee D, Cannon M, Capaldi RA, Tsien RY, Remington SJ (2004) Investigating mitochondrial redox potential with redox-sensitive green fluorescent protein indicators. *J Biol Chem* 279:13044–13053
- Harada E, Kusano T, Sano H (2000) Differential expression of genes encoding enzymes involved in sulfur assimilation pathways in response to wounding and jasmonate in *Arabidopsis thaliana*. *J Plant Physiol* 156:272–276
- Hartmann T, Honicke P, Wirtz M, Hell R, Rennenberg H, Kopriva S (2004) Regulation of sulphate assimilation by glutathione in poplars (*Populus tremula* P. alba) of wild type and overexpressing  $\gamma$ -glutamylcysteine synthetase in the cytosol. *J Exp Bot* 55:837–845
- Heiss S, Wachter A, Bogs J, Cobbett C, Rausch T (2003) Phytochelatin synthase (PCS) protein is induced in *Brassica juncea* leaves after prolonged Cd exposure. *J Exp Bot* 54:1833–1839
- Hell R, Bergmann L (1990)  $\gamma$ -Glutamylcysteine synthetase in higher plants: catalytic properties and subcellular localization. *Planta* 180:603–612
- Herbinger K, Tausz M, Wonisch A, Soja G, Sorger A, Grill D (2002) Complex interactive effects of drought and ozone stress on the antioxidant defense systems of two wheat cultivars. *Plant Physiol Biochem* 40:691–696

- Hérouart D, Van Montagu M, Inzé D (1993) Redox-activated expression of the cytosolic copper/zinc superoxide dismutase gene in *Nicotiana*. *Proc Natl Acad Sci USA* 90:3108–3112
- Hisabori T, Motohashi K, Hosoya-Matsuda N, Ueoka-Nakanishi H, Romano PGN (2007) Towards a functional dissection of thioredoxin networks in plant cells. *Photochem Photobiol* 83:145–151
- Huang CS, Chang LS, Anderson ME, Meister A (1993) Catalytic and regulatory properties of the heavy subunit of rat kidney  $\gamma$ -glutamylcysteine synthetase. *J Biol Chem* 268:19675–19680
- Ito H, Iwabuchi M, Ogawa K (2003) The sugar-metabolic enzymes aldolase and triose-phosphate isomerase are targets of glutathionylation in *Arabidopsis thaliana*: detection using biotinylated glutathione. *Plant Cell Physiol* 44:655–660
- Jain M, Choudhary D, Kale RK, Bhalla-Sarin N (2002) Salt and glyphosate-induced increase in glyoxalase I activity in cell lines of groundnut (*Arachis hypogea*). *Physiol Plant* 114:499–505
- Jez JM, Cahoon RE, Chen S (2004) *Arabidopsis thaliana* glutamate-cysteine ligase: functional properties, kinetic mechanism, and regulation of activity. *J Biol Chem* 279:33463–33470
- Katsuhara M, Otsuka T, Ezaki B (2005) Salt stress-induced lipid peroxidation is reduced by glutathione S-transferase, but this reduction of lipid peroxides is not enough for a recovery of root growth in *Arabidopsis*. *Plant Sci* 169:369–373
- Kocsy G, von Ballmoos P, Rueggsegger A, Szalai G, Galiba G, Brunold C (2001) Increasing the glutathione content in a chilling-sensitive maize genotype using safeners increased protection against chilling-induced injury. *Plant Physiol* 127:1147–1156
- Lascano HR, Antonicelli GE, Luna CM, Melchiorre MN, Gomez LD, Racca RW, Trippi VS, Casano LM (2001) Antioxidant system response of different wheat cultivars under drought: field and *in vitro* studies. *Aust J Plant Physiol* 28:1095–1102
- Leipner J, Fracheboud Y, Stamp P (1999) Effect of growing-season on the photosynthetic apparatus and leaf antioxidative defenses in two maize genotypes of different chilling tolerance. *Environ Exp Bot* 42:129–139
- Lemaire SD (2004) The glutaredoxin family in oxygenic photosynthetic organisms. *Photosynth Res* 79:305–318
- Lemaire SD, Michelet L, Zaffagnini M, Massot V, Issakidis-Bourguet E (2007) Thioredoxins in chloroplasts. *Curr Genet* 51:343–365
- Loggini B, Scartazza A, Brugnoli E, Navari-Izzo F (1999) Antioxidative defense system, pigment composition, and photosynthetic efficiency in two wheat cultivars subjected to drought. *Plant Physiol* 119:1091–1099
- Loscos J, Naya L, Ramos J, Clemente MR, Matamoros MA, Becana M (2006) A reassessment of substrate specificity and activation of phytochelatin synthases from model plants by physiologically-relevant metals. *Plant Physiol* 140:1213–1221
- Lu YP, Li ZS, Drozdowicz YM, Hortensteiner S, Martinoia E, Rea PA (1998) AtMRP2, an *Arabidopsis* ATP binding cassette transporter able to transport glutathione S-conjugates and chlorophyll catabolites: functional comparisons with AtMRP1. *Plant Cell* 10:267–282
- Martin MN, Slovin JP (2000) Purified  $\gamma$ -glutamyl transpeptidases from tomato exhibit high affinity for glutathione and glutathione S-conjugates. *Plant Physiol* 122:1417–1426
- Meyer AJ, Fricker MD (2002) Control of demand-driven biosynthesis of glutathione in green *Arabidopsis* suspension culture cells. *Plant Physiol* 130:1927–1937
- Meyer AJ, Hell R (2005) Glutathione homeostasis and redox-regulation by sulfhydryl groups. *Photosynth Res* 86:435–457
- Meyer AJ, May MJ, Fricker M (2001) Quantitative *in vivo* measurement of glutathione in *Arabidopsis* cells. *Plant J* 27:67–78
- Michelet L, Zaffagnini M, Marchand C, Collin V, Decottignies P, Tsan P, Lancelin JM, Trost P, Miginiac-Maslow M, Noctor G, Lemaire SD (2005) Glutathionylation of chloroplast thioredoxin f is a redox signaling mechanism in plants. *Proc Natl Acad Sci USA* 102:16478–16483
- Mitova V, Theodoulou FL, Kiddle G, Gomez L, Volokita M, Tal M, Foyer CH, Guy M (2003) Coordinate induction of glutathione biosynthesis and glutathione-metabolizing enzymes is correlated with salt tolerance in tomato. *FEBS Lett* 554:417–421
- Morita S, Kaminaka H, Masumura T, Tanaka K (1999) Induction of rice cytosolic ascorbate peroxidase mRNA by oxidative stress: the involvement of hydrogen peroxide in oxidative stress signaling. *Plant Cell Physiol* 40:417–422
- Mukherjee SP, Choudhuri MA (1983) Implications of water stress-induced changes in the levels of endogenous ascorbic acid and hydrogen peroxide in *Vigna* seedlings. *Physiol Plant* 58:166–170
- Noctor G, Foyer CH (1998) Ascorbate and glutathione: keeping active oxygen under control. *Annu Rev Plant Physiol Plant Mol Biol* 49:249–279
- Noctor G, Arisi ACM, Jouanin L, Valadier M-H, Roux Y, Foyer CH (1997) The role of glycine in determining the rate of glutathione synthesis in poplar: possible implications for glutathione production during stress. *Physiol Plant* 100:255–263
- Noctor G, Veljovic-Jovanovic S, Foyer CH (2000) Peroxide processing in photosynthesis: antioxidant coupling and redox signaling. *Proc Royal Soc London B* 355:1465–1475
- Noctor G, Veljovic-Jovanovic S, Driscoll S, Novitskaya L, Foyer CH (2002) Drought and oxidative load in the leaves of C-3 plants: a predominant role for photorespiration? *Ann Bot* 89:841–850
- Ogawa K, Hatano-Iwasaki A, Yanagida M, Iwabuchi M (2004) Level of glutathione is regulated by ATP-depend-

- ent ligation of glutamate and cysteine through photosynthesis in *Arabidopsis thaliana*: mechanism of strong interaction of light intensity with flowering. *Plant Cell Physiol* 45:1–8
- Payton P, Webb R, Kornyejev D, Allen R, Holaday AS (2001) Protecting cotton photosynthesis during moderate chilling at high light intensity by increasing chloroplastic antioxidant enzyme activity. *J Exp Bot* 52:2345–2354
- Pignocchi C, Foyer CH (2003) Apoplastic ascorbate metabolism and its role in the regulation of cell signaling. *Curr Opin Plant Biol* 6:379–389
- Pinhero RG, Rao MV, Paliyath G, Murr DP, Fletcher RA (1997) Changes in activities of antioxidant enzymes and their relationship to genetic and paclobutrazol-induced chilling tolerance of maize seedlings. *Plant Physiol* 114:695–704
- Porrás P, Pedrajas J, Martínez-Galisteo E, Padilla C, Johansson C, Holmgren A, Barcena J (2002) Glutaredoxins catalyze the reduction of glutathione by dihydrolipoamide with high efficiency. *Biochem Biophys Res Commun* 295:1046–1051
- Preger V, Scagliarini S, Pupillo P, Trost P (2004) Identification of an ascorbate-dependent cytochrome *b* of the tonoplast membrane sharing biochemical features with members of the cytochrome *b561* family. *Planta* 220:365–375
- Rea PA, Li ZS, Lu YP, Drozdowicz YM, Martinoia E (1998) From vacuolar GS-X pumps to multispecific ABC transporters. *Annu Rev Plant Physiol Plant Mol Biol* 49:727–760
- Rentel MC, Lecourieux D, Ouaked F, Usher SL, Petersen L, Okamoto H, Knight H, Peck SC, Grierson CS, Hirt H, Knight MR (2004) OX11 kinase is necessary for oxidative burst-mediated signaling in *Arabidopsis*. *Nature* 427:858–861
- Rey P, Bécuwe N, Barrault MB, Rumeau D, Havaux M, Biteau B, Toledano MB (2007) The *Arabidopsis thaliana* sulfiredoxin is a plastidic cysteine-sulfinic acid reductase involved in the photooxidative stress response. *Plant J* 49:505–514
- Romero LC, Dominguez-Solis JR, Gutierrez-Alcala G, Gotor C (2001) Salt regulation of O-acetylserine(thiol) lyase in *Arabidopsis thaliana* and increased tolerance in yeast. *Plant Physiol Biochem* 39:643–647
- Rouhier N, Gelhaye E, Jacquot J (2004) Plant glutaredoxins: still mysterious reducing systems. *Cell Mol Life Sci* 61:1266–1277
- Roxas VP, Lodhi SA, Garrett DK, Mahan JR, Allen RD (2000) Stress tolerance in transgenic tobacco seedlings that overexpress glutathione S-transferase/glutathione peroxidase. *Plant Cell Physiol* 41:1229–1234
- Ruiz JM, Blumwald E (2002) Salinity-induced glutathione synthesis in *Brassica napus*. *Planta* 214:965–969
- Sairam RK, Srivastava GC, Agarwal S, Meena RC (2005) Differences in antioxidant activity in response to salinity stress in tolerant and susceptible wheat genotypes. *Biol Plant* 49:85–91
- Samuel MA, Miles GP, Ellis BE (2000) Ozone treatment rapidly activates MAPK signaling in plants. *Plant J* 22:367–376
- Schafer FQ, Buettner GR (2001) Redox environment of the cell as viewed through the redox state of the glutathione disulfide/glutathione couple. *Free Radic Biol Med* 30:1191–1212
- Schäfer HJ, Haag-Kerwer A, Rausch T (1998) cDNA cloning and expression analysis of genes encoding GSH synthesis in roots of the heavy-metal accumulator *Brassica juncea* L.: evidence for Cd-induction of a putative mitochondrial  $\gamma$ -glutamylcysteine synthetase isoform. *Plant Mol Biol* 37:87–97
- Scheibe R, Backhausen J, Emmerlich V (2005) Strategies to maintain redox homeostasis during photosynthesis under changing conditions. *J Exp Bot* 56:1481–1489
- Schneider A, Scbatten T, Rennenberg H (1994) Exchange between phloem and xylem during long distance transport of glutathione in spruce trees (*Picea abies* [Karst.] L.). *J Exp Bot* 45: 457–462
- Schupp R, Rennenberg H (1988) Diurnal changes in the glutathione content of spruce needles (*Picea abies* L.). *Plant Sci* 57:113–117
- Shalata A, Mittova V, Volokita M, Guy M, Tal M (2001) Response of the cultivated tomato and its wild salt-tolerant relative *Lycopersicon pennellii* to salt-dependent oxidative stress: the root antioxidative system. *Physiol Plant* 112:487–494
- Singla-Pareek SL, Reddy MK, Sopory SK (2003) Genetic engineering of the glyoxalase pathway in tobacco leads to enhanced salinity tolerance. *Proc Natl Acad Sci USA* 100:14672–14677
- Singla-Pareek SL, Yadav SK, Pareek A, Reddy MK, Sopory SK (2006) Transgenic tobacco overexpressing glyoxalase pathway enzymes grow and set viable seeds in Zinc-spiked soils. *Plant Physiol* 140:613–623
- Smirnov N (1993) The role of active oxygen in the response of plants to water deficit and desiccation. *New Phytol* 125:27–58
- Schneider A, Scbatten T, Rennenberg H (1994) Exchange between phloem and xylem during long distance transport of glutathione in spruce trees (*Picea abies* [Karst.] L.). *J Exp Bot* 45:457–462
- Steinkamp R, Rennenberg H (1985) Degradation of glutathione in plant cells: evidence against the participation of a  $\gamma$ -glutamyltranspeptidase. *Z Naturf* 40c:29–33
- Storozhenko S, Belles-Boix E, Babiychuk E, Herouart D, Davey MW, Slooten L, Van Montagu M, Inze D, Kushnir S (2002)  $\gamma$ -glutamyl transpeptidase in transgenic tobacco plants: cellular localization, processing and biochemical properties. *Plant Physiol* 128:1109–1119
- Sun WM, Huang ZZ, Lu SC (1996) Regulation of  $\gamma$ -glutamylcysteine synthetase by protein phosphorylation. *Biochem J* 320:321–328
- Tausz M, Wonisch A, Peters J, Jimenez MS, Morales D, Grill D (2001) Short-term changes in free-radical scavengers and chloroplast pigments in *Pinus canariensis* needles as affected by mild drought stress. *J Plant Physiol* 158:213–219



- Tausz M, Sircelj H, Grill D (2004) The glutathione system as a stress marker in plant ecophysiology: is a stress-response concept valid? *J Exp Bot* 55:1955–1962
- Tavakoli N, Kluge C, Golldack D, Mimura T, Dietz KJ (2001) Reversible redox control of plant vacuolar H<sup>+</sup>-ATPase activity is related to disulfide bridge formation in subunit E as well as subunit A. *Plant J* 28:51–59
- Vaidyanathan H, Sivakumar P, Chakrabarty R, Thomas G (2003) Scavenging of reactive oxygen species in NaCl-stressed rice (*Oryza sativa* L.) – differential response in salt-tolerant and sensitive varieties. *Plant Sci* 165:1411–1418
- Wachter A, Wolf S, Steininger H, Bogs J, Rausch T (2005) Differential targeting of GSH1 and GSH2 is achieved by multiple transcription initiation: implications for the compartmentation of glutathione biosynthesis in the brassicaceae. *Plant J* 41:15–30
- Walker MA, McKersie BD (1993) Role of the ascorbate-glutathione antioxidant system in chilling resistance of tomato. *J Plant Physiol* 141:234–239
- Wildi B, Lutz C (1996) Antioxidant composition of selected high alpine plant species from different altitudes. *Plant Cell Environ* 19:138–146
- Wise RR, Naylor AW (1987) Chilling-enhanced photo-oxidation: the peroxidative destruction of lipids during chilling injury to photosynthesis and ultra structure. *Plant Physiol* 83:272–277
- Woo L, Jeong HA, Chang W, Park T-S, Park KW, Yang JS, Rhee SG (2005) Reduction of cysteine sulfinic acid by sulfiredoxin is specific to 2-cys peroxiredoxins. *J Biol Chem* 280:3125–3128
- Xiang C, Bertrand D (2000) Glutathione synthesis in *Arabidopsis*: multilevel controls coordinate responses to stress. In: Brunold C, Rennenberg H, De Kok LJ, Stulen I, Davidian JC (eds) Sulfur nutrition and sulfur assimilation in higher plants. Paul Haupt, Bern, Switzerland, pp 409–412
- Xiang C, Oliver DJ (1998) Glutathione metabolic genes coordinately respond to heavy metals and jasmonic acid in *Arabidopsis*. *Plant Cell* 10:1539–1550
- Xiang C, Werner BL, Christensen EM, Oliver DJ (2001) The biological functions of glutathione revisited in *Arabidopsis* transgenic plants with altered glutathione levels. *Plant Physiol* 126:564–574
- Xing S, Rosso MG, Zachgo S (2005) ROXY1, a member of the plant glutaredoxin family, is required for petal development in *Arabidopsis thaliana*. *Development* 132:1555–1565
- Xu CC, Li L, Kuang T (2000) The inhibited xanthophyll cycle is responsible for the increase in sensitivity to low temperature photoinhibition in rice leaves fed with glutathione. *Photosynth Res* 65:107–114
- Yan Y, Wei CL, Zhang WR, Cheng HP, Liu J (2006) Cross-talk between calcium and reactive oxygen species signaling. *Acta Pharmacol Sinica* 27:821–826
- Zhang MY, Bourbouloux A, Cagnac O, Srikanth CV, Rentsch D, Bachhawat AK, Delrot S (2004) A novel family of transporters mediating the transport of glutathione derivatives in plants. *Plant Physiol* 134:482–491
- Zhu YL, Pilon-Smits EA, Tarun AS, Weber SU, Jouanin L, Terry N (1999) Cadmium tolerance and accumulation in Indian mustard is enhanced by over expressing  $\gamma$ -glutamylcysteine synthetase. *Plant Physiol* 121:1169–1178

# Chapter 14

## Water Balance and the Regulation of Stomatal Movements

Christophe Belin and Sébastien Thomine  
*Institut des Sciences du Végétal, Centre National de la Recherche Scientifique,  
91198 Gif-sur-Yvette, France*

Julian I. Schroeder\*  
*Division of Biological Sciences, Cell and Developmental Biology Section,  
University of California, San Diego, La Jolla, CA 92093-0116, USA*

Summary .....	284
I Introduction .....	284
II How Does Water Balance Affect Stomatal Movements? .....	285
A Water Balance Sensing and Information Transfer to Stomata .....	285
1 Stomatal Response to Limited Water Availability in Soils .....	285
2 Stomatal Response to Decreased Relative Air Humidity .....	287
B Regulation of Active ABA Concentrations by Water Balance .....	287
1 ABA Metabolism .....	287
2 ABA Transport and Sequestration .....	288
III Mechanism of Stomatal Movements and Its Regulation by Water Balance .....	288
A Cellular and Molecular Mechanisms of Stomatal Movements .....	288
1 Changes in Guard Cell Turgor are Responsible for Stomatal Movements .....	288
2 Channels and Transporters: Important Effectors Mediating Stomatal Movements .....	290
3 Reorganization of Membranes and Cytoskeleton .....	291
B Signal Transduction Processes Controlling Stomatal Aperture .....	292
1 Abscisic Acid Signal Transduction Mechanisms in Guard Cells .....	292
2 Guard Cell Signal Transduction Network .....	295
3 Other Stomatal Closing Stimuli Cross-Talk Through the Guard Cell Signaling Network .....	295
IV Genes and Promoters of Interest to Manipulate Stomatal Function in Crop Plants .....	297
V Conclusion .....	297
Acknowledgements .....	298
References .....	298

---

Author for Correspondence, e-mail: [Julian@biomail.ucsd.edu](mailto:Julian@biomail.ucsd.edu)

## Summary

Stomata form a crucial interface between plants and the atmosphere and are essential to the control of water balance in plants. Prolonged soil dehydration or a drop in atmospheric relative humidity lead to a decrease in biomass production, plant water loss and eventually death. For plants to survive, it is essential that stomata close in response to drought conditions. The phytohormone abscisic acid (ABA) has been shown to play a central role in this process. The first part of this chapter reviews the mechanisms by which drought is translated into signals that lead to stomatal closure, and especially the building up of bioactive ABA concentrations in and around guard cells. The second part introduces the biophysical and metabolic mechanisms used by guard cells to control stomatal aperture. Furthermore, we illustrate how these mechanisms are the target of a signal transduction network integrating drought with other environmental signals. Finally, the third part briefly proposes that stomata represent a putative target to engineer desiccation avoidance in plants.

**Keywords** stomata • ABA • drought avoidance • ion channels • osmotic pressure • signaling • water efficiency

## I Introduction

Drought is an important stress which threatens plant survival especially in arid or semi-arid and Mediterranean-like climates. Prolonged soil dehydration or a drop in atmospheric relative humidity lead to a decrease in biomass production, plant water loss and eventually death. To overcome drought stress, plants have evolved a number of adaptive responses including, e.g., shortening of the life cycle leading to early production of seeds,

modifications of root architecture and morphology and accumulation of solutes.

One of the fastest responses to alterations in water balance is the closing of stomatal pores at the surface of leaves. Stomata are formed by two kidney shaped guard cells which determine the size of the pore. Stomata control gas exchange between airspaces inside leaves and the surrounding atmosphere. CO<sub>2</sub> influx into leaves through stomatal pores affects photosynthetic efficiency while water vapor exchange is central to the maintenance of plant water balance. Gas exchange through stomata may be regulated at different levels. Stomatal density and morphology may vary between plants. Molecular mechanisms regulating stomatal development have been recently reviewed (Bergmann and Sack 2007). Identification of the HIC pathway provided the first evidence for a genetic mechanism through which stomatal density can be regulated by environmental cues, such as carbon dioxide partial pressure (Gray et al. 2000) and this topic has been reviewed recently (Barton 2007; Gray 2007). This chapter will not review the mechanisms controlling stomatal development. It will focus on the mechanisms regulating stomatal aperture under environmental conditions that challenge plant water balance. These conditions include soil dehydration triggering a decrease in water potential in the roots relative to the leaves, as well as a drop in atmospheric relative humidity

---

*Abbreviations:* AAO – ascorbate oxidase; ABA – abscisic acid; ABC – ATP-binding cassette transporters; ABI – ABA insensitive; AHG – ABA hypersensitive germination; AtBG – *Arabidopsis thaliana* β-glucosidase; AtKC*Arabidopsis thaliana* K<sup>+</sup> rectifying channel; cADPR – cyclic ADP-ribose; CDPK – calcium dependent protein kinase; FV – fast vacuolar; GCR2 – G-protein coupled receptor; GORK – guard cell outward rectifying K<sup>+</sup> channel; GPA – G protein alpha subunit; GTG – GPCR type G protein; HABI – homologue to ABI1 protein phosphatase; HIC – high carbon dioxide signaling pathway; IP – phosphoinositides; KAT – ketoacyl-coenzyme A thiolase; MPK – mitosis associated protein kinase; NCED – 9-*cis*-epoxycarotenoid dioxygenase enzymes; PEPC – phospho enol pyruvate carboxylase; PLC – phospholipase C; PLD – phospholipase D; PP2C – protein phosphatases type 2C; RNAi – RNA interference; RPK – receptor-like protein kinase; R-type channels – rapid-type anion channels; S-type channels – slow-type anion channels; SV – slow vacuolar; TPC – two pore channel; VK – K<sup>+</sup>-selective vacuolar

resulting in a drop in the water potential in the surrounding atmosphere relative to the inside of the leaves. For plants to survive it is essential that stomata close in response to drought conditions. The phytohormone abscisic acid (ABA) has been shown to play a central role in this process. However in the context of natural competition, plants need to optimize photosynthesis and stomata have to integrate different environmental parameters such as light, CO<sub>2</sub> concentration and pathogen attack together with drought signals and to react timely and locally to environmental changes to finely tune gas exchange.

In this chapter, we will first review the mechanisms by which drought is translated into signals that lead to stomatal closure, and especially the building up of bioactive ABA concentrations in the vicinity of guard cells. We will then introduce the biophysical and metabolic mechanisms that are used by guard cells to control stomatal aperture. We will furthermore outline how these mechanisms are the target of a signal transduction network integrating drought with other environmental parameters. Finally, we will consider how the basic knowledge available may be harnessed to improve crop plant productivity under challenging hydration conditions.

## II How Does Water Balance Affect Stomatal Movements?

### *A Water Balance Sensing and Information Transfer to Stomata*

Water balance can be disturbed by alteration of water supply, through a decrease in water availability in soils due to drought, cold or saline stress, and/or modifications of the evaporative demand, which depends on relative atmospheric humidity. Stomata are able to sense and respond to these changes in environmental conditions to avoid water deficiency in the plant. ABA is an important signal by which plants can transmit information to stomata. Some studies have also revealed the existence of both ABA-dependent and ABA-independent pathways in response to osmotic stresses (Shinozaki and Yamaguchi-Shinozaki 1996). Nevertheless, genetic studies of plants mutants that display enhanced water loss have clearly indicated a major role for abscisic

acid synthesis and signaling for drought-induced stomatal movements. Moreover, genetic evidence linking changes in atmospheric humidity to ABA signaling has recently been reported (Xie et al. 2006). In this section, we attempt to give a state-of-the-art description of water balance sensing and signaling (Fig. 1).

### *1 Stomatal Response to Limited Water Availability in Soils*

#### 1.1 An Early Root-to-Shoot Signal

Decrease in soil water availability leads to root dehydration. Studies have revealed that the resulting drop in the root water potential ( $\Psi_r$ ) is able to trigger stomatal responses before shoot water potential declines (Gowing et al. 1990). Split-root experiments have shown that stomata can close in response to exposure of one half of the roots to water stress, whereas water status in shoots is still unchanged. This supports the existence of a chemical or physical signal coming from roots submitted to water stress, as soon as the soil water potential decreases by only a few kPa (for review, see Davies et al. 2002).

#### 1.2 ABA Is the Main Signal

ABA plays a central role in this long-distance signaling process (Gowing et al. 1990; 1993). Indeed, mutants affected in ABA biosynthesis (Koornneef et al. 1982; Leon-Kloosterziel et al. 1996; Marin et al. 1996) or plants expressing an antibody raised against ABA (Artsaenko et al. 1995) are unable to close their stomata and share a severe wilted phenotype in response to water deficit. Application of exogenous ABA can rescue this phenotype. Moreover, many studies have reported the relation between ABA content of roots or xylem and soil water status (Zhang and Davies 1990). Thus, the increase in ABA biosynthesis and the transfer of ABA to the xylem in roots have been proposed to mediate plant responses to water limitation in soils. However, despite a physiological contribution of this process, ABA concentrations in roots or xylem are not always correlated to the soil water status. A recent publication reported a good correlation between ABA concentrations in target tissues (i.e., stomata) and soil water status, with only limited and delayed changes in ABA contents in the root vasculature (Christmann et al. 2005). This study used ABA-induced promoter::Luciferase reporter plants to



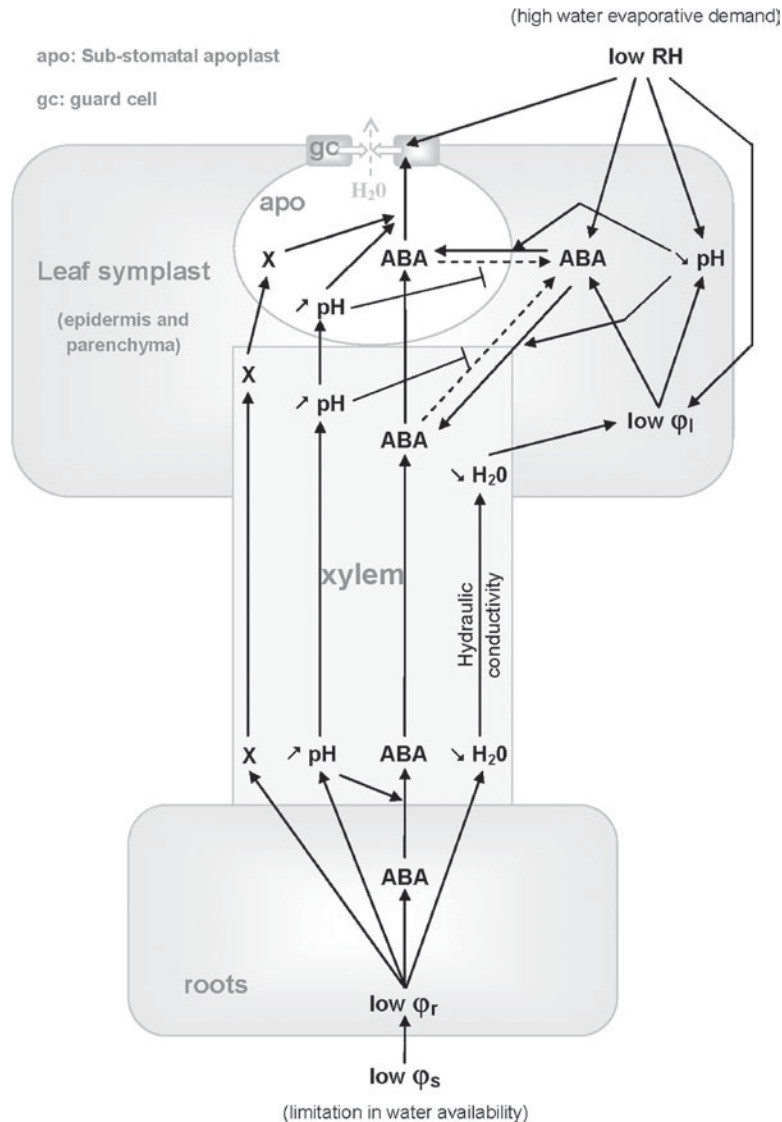

Fig. 1. ABA is the central signal which triggers stomatal closure in response to water stress. This figure represents all proposed pathways leading to stomatal closure in response to water stress. X: other substances of which the concentration in xylem sap is regulated in response to water deprivation (e.g., calcium, potassium, nitrates, other hormones); RH: relative humidity;  $\Psi_s$ ,  $\Psi_r$  and  $\Psi_l$ : water potential of soil, roots and leaves, respectively.

estimate where and when ABA is synthesized in response to root dehydration. The authors showed rapid and large increases in ABA in *Arabidopsis* shoots, suggesting that a primary site for ABA synthesis lies in the shoots in response to root dehydration (Christmann et al. 2005).

### 1.3 The Hydraulic Signal

The finding that ABA is synthesized in leaves in response to root dehydration (Christmann et al. 2005), has been further strengthened using

a combination of ABA reporter constructs and grafting roots of ABA biosynthesis mutants to wild-type shoots (Christmann et al. 2007). This study provides evidence for a model in which, upon root dehydration, leaves sense the drop in hydraulic pressure leading to ABA synthesis in leaves (Fig. 1). Thus, when deficits in soil water availability triggers a decrease in the water potential of leaves ( $\Psi_l$ ), ABA is de novo synthesized within leaves and may function together with the

apparently more limited levels of ABA that are transferred from roots to shoots.

**1.4 Additional Root-Sourced Chemical Signals Implicated in Stomatal Responses to Soil Water Status**  
Water stress has been shown to trigger other chemical signals generated in roots and transmitted through the xylem. Among them, xylem sap alkalization has been reported to be another important root-derived signal which is often correlated to soil water status and stomatal movements (Hartung and Radin, 1989; Gollan et al., 1992; Wilkinson et al., 1998). However, some studies have shown that xylem sap alkalization can trigger stomatal closure only when ABA is present in the xylem (Wilkinson and Davies, 1997). This suggests that the root-sourced ABA and pH interact to signal a limitation in soil water availability. Changes in inorganic ions (e.g., nitrate, calcium, potassium) and other phytohormones (e.g., cytokinins) have also been observed in response to soil drying (Radin et al., 1982; Incoll and Jewer, 1987; Stoll et al., 2000; Wilkinson et al., 2001). These signals may contribute to modulation of the ABA-sensitivity of guard cells.

## 2 Stomatal Response to Decreased Relative Air Humidity

Responses to decrease in Relative Humidity (RH) in the air surrounding leaves have been less extensively studied than responses to changes in soil water status (e.g., soil drying). A dry atmosphere, and thus increased water evaporation from leaves, triggers stomata to close to prevent excessive water loss (Buckley 2005). However, several mechanisms have been proposed to explain how stomata could sense these changes (Fig. 1).

A recent study has provided genetic evidence that ABA is involved in the response to decreased air humidity: *aba2* and *ost1* mutations, respectively affecting ABA biosynthesis and transduction, were isolated in this genetic screen based on a stomatal insensitivity to an imposed drop in atmospheric relative humidity (Xie et al. 2006). In contrast, an earlier study reported that other mutants affected in ABA biosynthesis (*aba1*) and transduction (*abi1-1* and *abi2-1*) displayed wild type responses to reduced relative air humidity (Assmann et al. 2000). Taken together, these data provide evidence from a genetic screen that

responses to a decrease in atmospheric humidity are mediated by ABA and that additional signals may also mediate stomatal closing. Thus recent studies are suggesting new functions and mechanisms by which ABA signaling contributes to responses to soil drought and a drop in atmospheric relative humidity.

## B Regulation of Active ABA Concentrations by Water Balance

### 1 ABA Metabolism

Endogenous ABA levels fluctuate in response to changes in environmental conditions that threaten the water balance of plants. Endogenous ABA levels are controlled by mechanisms of ABA biosynthesis, degradation and conjugation. These mechanisms have been extensively reviewed (Nambara and Marion-Poll 2005). ABA is a sesquiterpenoid molecule synthesized in the cytosol from the xanthoxin C<sub>15</sub> precursor via the production of abscisic aldehyde. This xanthoxin is produced by the cleavage of carotenoids (9-*cis*-epoxycarotenoids) in the chloroplast. ABA can be inactivated by hydroxylation or by conjugation with glucose derivatives, which allows to store inactive ABA pools (mainly ABA glucosylesters) in the vacuole or the apoplast.

Synthesis of xanthoxin is mediated by the family of 9-*cis*-epoxycarotenoid dioxygenase enzymes (NCED), which are encoded by five genes in *Arabidopsis*. *AtNCED3* plays a crucial role in ABA-mediated responses to drought (Iuchi et al. 2001). Indeed, *AtNCED3* is rapidly up-regulated in response to drought stress. Moreover, the ABA levels and the resistance to drought are severely affected in the loss-of-function *nced3* mutant. A recent study has shown that other genes involved in ABA biosynthesis (like *ABA1*, *ABA3* or *AAO3*) can also be up-regulated by osmotic stress, but to a lesser extent (Barrero et al. 2006). Finally, a positive feedback control by ABA on its own biosynthesis, via the induction of the same genes (*NCED3* and, to a lesser extent, *ABA1*, *ABA3*, *AAO3*), also participates in the control of ABA levels.

Water balance also controls ABA catabolism. Indeed, *CYP707A3* mRNA is strongly induced by rehydration after dehydration stress

(Kushiro et al. 2004; Umezawa et al. 2006). This enzyme belongs to the CYP707A sub-family of cytochrome P<sub>450</sub> which catalyze the 8'-hydroxylation of ABA to form phaseic acid, the main pathway responsible for ABA degradation.

Finally, a recent study has indicated a role for a  $\beta$ -glucosidase (AtBG1) in plant tolerance to abiotic stresses (Lee et al. 2006). AtBG1 hydrolyzes ABA glucosylesters allowing rapid enhancement of bioactive ABA levels upon decrease in leaf water potential (Lee et al. 2006). Water balance thus controls bioactive ABA levels by regulating its biosynthesis, degradation and conjugation.

## 2 ABA Transport and Sequestration

Some studies have indicated that ABA levels in the xylem sap of well-watered plants would often be sufficient to maintain stomata continuously closed if they were directly exposed to such concentrations (Trejo et al. 1993, 1995). This suggested that ABA concentrations may be actively reduced between the xylem and guard cells through "filtration" by leaf cells (Trejo et al. 1995). Indeed, cytosolic pH inside leaf cells is about 1.5 units more alkaline than the pH of the cell wall or the xylem. As a weak acidic molecule, ABA is under a protonated form in the cell wall and can enter leaf cells via diffusion, where it is de-protonated maintaining a gradient favoring ABA influx. ABA is thus sequestered and eventually degraded in leaf cells (Trejo et al. 1993; Daeter and Hartung 1995).

During drought stress, the xylem and leaf apoplast become more alkaline. Under these conditions, ABA removal from the leaf apoplast by leaf cells is strongly reduced (Jia and Zhang 1997; Sauter et al. 2001). More ABA can thus reach the apoplast surrounding guard cells. In addition, local de novo ABA biosynthesis and ABA deconjugation triggered by leaf dehydration may bypass leaf filtration.

Altogether, alterations in the water balance lead to building up of elevated ABA concentrations in the vicinity of guard cells. The following section describes the mechanism of stomatal movements and highlights the signaling network through which ABA and other signals are integrated by guard cells to control plant transpiration.

## III Mechanism of Stomatal Movements and Its Regulation by Water Balance

### A Cellular and Molecular Mechanisms of Stomatal Movements

#### 1 Changes in Guard Cell Turgor are Responsible for Stomatal Movements

Stomata are turgor-responsive valves in the leaf epidermis in plants. The lack of plasmodesmata in mature guard cells enables rapid modifications of cell turgor (Wille and Lucas 1984). Moreover, the kidney-like shape, the thickening of cell walls, as well as the radial orientation of cellulose fibrils enable specific deformations of the pair of guard cells surrounding each stomatal pore in response to turgor variations to regulate the pore aperture (Franks et al. 1998).

Stomatal movements are due to the regulation of guard cell turgor via the control of osmolyte concentrations in their cytosol (Fischer 1968; Pandey et al. 2007). During stomatal opening, accumulation of osmotically active solutes leads to an increase in the osmotic potential and a decrease in water potential in guard cells. A massive influx of water into the guard cell compensates this water potential decrease, leading to an increase of turgor and the swelling of guard cells. Conversely, decreasing osmolyte concentrations leads to a massive water efflux from guard cells, which results in the reduction of guard cells turgor and closure of stomata (Fig. 2). All fluxes are coupled between tonoplast and plasma membrane since osmolytes and water are mainly sequestered in the vacuole.

A variety of osmolytes, mainly inorganic ions and carbohydrate compounds (Raschke 1979; Talbott and Zeiger 1996), may be responsible for the regulation of guard cell turgor. Their relative importance has been reported to depend on plant species, physiological status and the time of day. Several monovalent cations can affect guard cells osmotic potential but K<sup>+</sup> is the most relevant as it accumulates at high concentrations in guard cells, which leads to stomatal opening (Humble and Raschke 1971; MacRobbie and Lettau 1980). K<sup>+</sup> uptake is mainly responsible for the rapid increase of turgor and stomatal opening during the "morning" phase of the day (Humble and Raschke 1971; Talbott and Zeiger 1996). The potassium

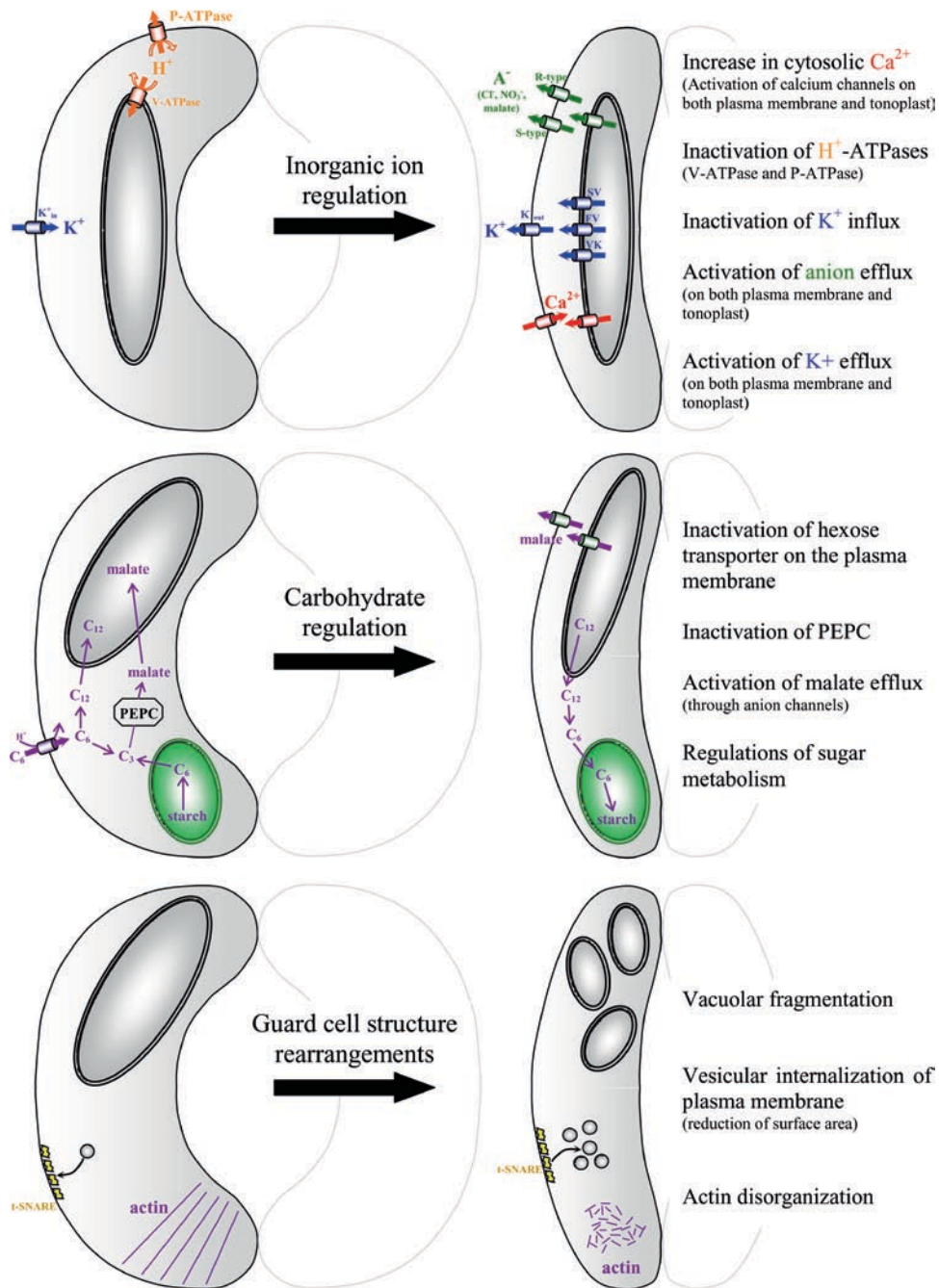

Fig. 2. Mechanisms of Abscisic Acid (ABA)-induced stomatal closure. The regulation of inorganic ion concentration and carbohydrate content in guard cells triggers the decrease in osmotic pressure and a massive water efflux. Concomitantly, structural rearrangements facilitate stomatal closure [See Color Plate 7, Fig. 13].

influx is electrically neutralized by the extrusion of protons and the uptake of anions, essentially malate, Cl<sup>-</sup> and nitrate. Finally, accumulation of sugars (glucose, fructose, sucrose) in guard cells, has been reported in a few studies, especially

during the “light phase” of the day, to complete or maintain K<sup>+</sup>-induced turgor (Talbot and Zeiger 1998). Sugars may be extruded from guard cells during stomatal closure. Further studies into the contributions of sugars would be of interest.



## 2 Channels and Transporters: Important Effectors Mediating Stomatal Movements

Ion channels and transporters are major players in ion and osmolyte fluxes mediating stomatal movements (Schroeder et al. 2001a, b; Pandey et al. 2007) (Fig. 2). Guard cells constitute an excellent system for electrophysiological studies as they are isolated from the symplasmic network. Numerous studies on several model plant species (*Arabidopsis thaliana* and *Vicia faba*) have provided an understanding of the molecular mechanisms that mediate ion fluxes during stomatal movements. Here, we focus on the main effectors participating in stomatal closure in response to ABA.

### 2.1 Anion Channels Triggered by ABA

ABA activates plasma membrane anion channels which trigger anion efflux and depolarization. Two types of anion channels have been characterized: “slow (S)-type” anion channel activation is slow, prolonged and exhibits a weak voltage-dependence allowing anion efflux in a broad voltage range (Schroeder and Hagiwara 1989; Schroeder and Keller 1992). “Rapid (R)-type” anion channels are subject to fast, transient and voltage-dependent activation (Keller et al. 1989; Schroeder and Keller 1992). Physiological, pharmacological and genetic studies have suggested that anion channels are a rate-limiting mechanism in the mediation of stomatal closing (Pandey et al. 2007). Several studies have shown that S-type anion channels in guard cells from different species are activated by ABA, cytosolic  $\text{Ca}^{2+}$  and phosphorylation events (Schmidt et al. 1995; Pei et al. 1997; Leonhardt et al. 1999; Raschke et al. 2003; Roelfsema et al. 2004; Mori et al. 2006). Recent studies have shown that R-type anion channels are also activated by abscisic acid (Raschke et al. 2003; Roelfsema et al. 2004).

Mutants in the *SLAC1* gene display strongly impaired response to a range of stomatal closing stimuli, ABA, high  $\text{CO}_2$ , calcium and  $\text{O}_3$ . *SLAC1* encodes a membrane protein with homology to dicarboxylate transporters; *slac1* mutant guard cells completely lack S-type anion currents but display wild type R-type anion currents. *SLAC1* likely encodes slow anion channel (Negi et al. 2008; Vahisalu et al. 2008). Previous pharmacological work suggested that ATP-binding cassette (ABC) transporters could function in S-type

channel activity or regulation (Leonhardt et al. 1999). A recent study showed that the ABC transporter AtMRP5 is plasma membrane-localized and functions in regulation of S-type anion channels and  $\text{Ca}^{2+}$  channels in guard cells (Suh et al. 2007).

### 2.2 Proton Pumps

Proton pumps ( $\text{H}^+$ /ATPases) mediate proton extrusion from guard cells. Proton pumping is activated by blue light to initiate stomatal opening (Assmann et al. 1985; Shimazaki et al. 1986). Abscisic acid causes inhibition of proton pumping (Shimazaki et al. 1986) which facilitates membrane depolarization leading to stomatal closure (Goh et al. 1996). The importance of proton pump inhibition by ABA has recently been supported by genetic data from dominant mutations (Merlot et al. 2007): *Arabidopsis ost2* mutants, which carry mutations in the *AHA1* gene leading to constitutive activation of *AHA1*  $\text{H}^+$ -ATPase, are unable to close their stomata in response to ABA. Note that, given the complex network of signal transduction mechanisms in guard cells (Israelsson et al. 2006), it is likely that inhibition of proton pumping and anion channel activation represent some of the rate-limiting mechanisms in stomatal closing (Schroeder et al. 2001a, b; Merlot et al. 2007).

### 2.3 Potassium Channels

Potassium selective channels have been characterized as mechanisms that contribute to potassium uptake during stomatal opening and potassium release during stomatal closing (Schroeder et al. 1987). Two major classes of potassium channels have been characterized in the plasma membrane of guard cells (Schroeder et al. 1987). Inward-conducting  $\text{K}^+$  channels allow  $\text{K}^+$  influx inside guard cells when proton pump drives the plasma membrane to negative potential. Inward  $\text{K}^+$  channels are inhibited after ABA treatment and cytosolic  $\text{Ca}^{2+}$  elevation (Schroeder and Hagiwara 1989; Blatt and Armstrong 1993; Grabov and Blatt 1999). Outwardly-rectifying potassium channels are, in turn, activated by plasma membrane depolarization (Schroeder et al. 1987) which is observed after ABA treatment (Roelfsema et al. 2004).

Genes encoding plasma membrane inward-rectifying potassium channels were first described in plants prior to animal channels (Anderson et al.

1992; Schachtman et al. 1992; Sentenac et al. 1992). Several members of the “shaker” family of inward  $K^+$  channels (KAT1, KAT2, AKT1, AKT2/3, AtKC1) have been suggested to heteromerize in the plasma membrane of Arabidopsis guard cells to generate inward potassium currents (Anderson et al. 1992; Sentenac et al. 1992; Pilot et al. 2001; Szyroki et al. 2001). In contrast, depolarization activated outwardly rectifying  $K^+$  channel activity in the plasma membrane of guard cells is encoded by a single gene named *GORK* (Ache et al. 2000; Hosy et al. 2003). Although much work has focused on the two classes of inward and outward  $K^+$  channels in guard cells, additional types of  $K^+$  channels or transporters may play important roles in guard cells (Very and Sentenac 2003).

#### 2.4 Effectors of Osmotic Fluxes Across the Tonoplast

Tonoplast channels and transporters are important to regulate guard cell osmotic potential. Tracer flux analyses have shown significant  $Cl^-$  accumulation in guard cell vacuoles (MacRobbie 1983). CDPK activated  $Cl^-$  and malate channels from *Arabidopsis* guard cell vacuoles display voltage regulation in favor of a role in osmotic anion uptake during stomatal opening (Pei et al. 1996; Hafke et al. 2003). However, research is needed to determine the transport mechanisms for  $Cl^-$  and malate release from vacuoles during stomatal closing, which energetically may not be mediated by channels.

Three types of channels which allow  $K^+$  fluxes across the tonoplast have been characterized: “slow vacuolar” (SV), “fast vacuolar” (FV) and “ $K^+$ -selective Vacuolar” (VK) channels (Hedrich and Neher 1987; Ward and Schroeder 1994; Allen and Sanders 1996). SV channels are non-selective cation channels activated by cytosolic calcium, their regulation by membrane potential would favor potassium influx into the vacuole (Ward and Schroeder 1994).

SV channels were demonstrated to be calcium permeable (Ward and Schroeder 1994) and have also been proposed to also allow brief transient efflux of cations, including  $Ca^{2+}$ , from vacuoles, during channel deactivation. Data suggest that the voltage activation range of SV channels can be shifted towards vacuolar efflux (Scholz-Starke et al. 2005). Recently, the Arabidopsis TPC1 (“Two Pore Channel” 1) was shown to be required

for SV channel activity (Peiter et al. 2005). External  $Ca^{2+}$ -induced stomatal closure, but not ABA induced stomatal closure is impaired in *tpc1* knock-out plants.

In contrast to SV channels, FV channels display instantaneous activation and are inactivated by elevated cytosolic  $Ca^{2+}$  concentrations. The molecular identification of FV channel would be needed to better understand their function in guard cell osmoregulation.

VK channels are highly potassium selective and activated by elevated cytosolic calcium (Ward and Schroeder 1994). They have been proposed to mediate  $K^+$  efflux from the vacuole during stomatal closure (Ward and Schroeder 1994). Recently, a member of the Arabidopsis “two pore channel” family (TPK1) was shown to encode VK channel activity (Gobert et al. 2007). Interestingly, guard cells from *tpk1* knock-out mutants display a defect in ABA-induced stomatal closing consistent with their proposed role in  $K^+$  release.

#### 2.5 Carbohydrate Regulation

Carbohydrates such as sucrose, glucose or fructose can also be important osmolytes, particularly during light-induced stomatal opening or to maintain stomatal aperture in the afternoon (Fig. 2). The poor photosynthetic activity of guard cells suggests that these carbohydrates should be mainly imported from the apoplast or derived from starch (Vavasseur and Raghavendra 2005). In Arabidopsis, *AtSPT1* is specifically expressed in guard cells and encodes a monosaccharide- $H^+$  symporter which shares many properties with the hexose proton symporter described in pea (Ritte et al. 1999; Stadler et al. 2003). Carbohydrate metabolism was also implicated in the regulation of osmotically active sugar concentration during stomatal movements. Some studies have revealed the importance of starch breakdown for stomatal opening under blue light (Vavasseur and Raghavendra 2005). Moreover, specific regulation of PEPC could be implicated in the increase of malate in guard cells of open stomata (Du et al. 1997).

### 3 Reorganization of Membranes and Cytoskeleton

Important structural changes of guard cells occur concomitantly with the osmotic mechanisms presented above and are critical for stomatal

movements (Fig. 2). Guard cell volume is reduced by about 40% when stomata close. This is accompanied by a reduction of the membrane area via vesicle internalization (Shope et al. 2003). Plasma membrane rearrangements are also important for modulating distribution of channels described above, as shown for KAT1 potassium channels (Hurst et al. 2004; Sutter et al. 2007). t-SNAREs are implicated in vesicular trafficking and membrane fusions (Jahn and Sudhof 1999). Accordingly, mutants affected in t-SNARE syntaxins in tobacco (*Nt-SYR1*) and *Arabidopsis* (*OSM1/SYP61*) display greatly disturbed guard cell K<sup>+</sup> and Cl<sup>-</sup> current regulation in response to ABA, and alteration in ABA-induced stomatal closure, respectively (Leyman et al. 1999; Zhu et al. 2002). This supports the importance of plasma membrane reorganization in guard cell ABA responses. In addition, vacuolar organization is modified during guard cells shrinking (Gao et al. 2005; Tanaka et al. 2007).

Cytoskeleton rearrangements also occur during stomatal movements. In *Commelina communis*, radial-oriented actin filaments visible in turgid guard cells are fragmented in response to ABA (Eun et al. 2001). Moreover, the Rho-GTPase RAC1, which controls actin modifications, acts as a negative regulator of ABA signaling in guard cells (Lemichiez et al. 2001). Inactivation of RAC1 is required for ABA induced stomatal closure. Changes in microtubules organization also accompany stomatal movements but it is still unclear if these changes are required for ABA response (Yu et al. 2001; Lahav et al. 2004).

## B Signal Transduction Processes Controlling Stomatal Aperture

### 1 Abscisic Acid Signal Transduction Mechanisms in Guard Cells

Cell biological and more recently genetic approaches have revealed a complex signaling network connecting ABA perception to stomatal closing mostly via the modulation of ion channel activities (Schroeder et al. 2001a, b; Pandey et al. 2007).

#### 1.1 Abscisic Acid Perception

Recent research has identified four types of ABA receptors involved in the regulation of stomatal movements: GCR2, a putative G-protein coupled

receptor localized on the plasma membrane (Liu et al. 2007), GTG1 and GTG2, redundant bifunctional proteins containing a G protein coupled receptor and a G protein domain (Pandey et al. 2009), ABAR, the H-subunit of Mg chelatase localized in chloroplasts (Shen et al. 2006) and the PYR-PYL/RCAR multigene family belonging to the START family of bacterial toxin receptors (Ma et al. 2009; Park et al. 2009). Most of these have been reported to bind ABA with high affinity and high specificity. Mutations in these receptors have been reported to result in decreased ABA sensitivity of stomatal movements. Note that the role of GCR2 protein as G protein coupled ABA receptors is controversial and ABA insensitive phenotypes were not reproduced by others (Gao et al. 2007; Guo et al. 2008). Further research is needed to test models of ABA signal transduction proposed by these recent studies.

In addition, a receptor kinase like protein, RPK1, has been shown to positively regulate ABA signaling (Osakabe et al. 2005). This protein is localized at the plasma membrane. However, no evidence that it binds ABA is available and disruption of the *RPK1* gene was reported to result in a moderate decrease in ABA sensitivity.

#### 1.2 Genetic Screens Identify Kinases and Phosphatases

Initial screens for mutations conferring ABA insensitivity identified the *abi1-1* and *abi2-1* dominant mutations that confer strong ABA insensitivity in several major ABA responses (Koornneef et al. 1984). *ABI1* and *ABI2* encode protein phosphatases type 2C (PP2C) and point to the importance of phosphorylation/dephosphorylation processes in ABA signal transduction (Leung et al. 1994, 1997; Meyer et al. 1994). Loss-of-function mutations in the corresponding genes increase guard cell ABA sensitivity (Gosti et al. 1999; Merlot et al. 2001). Recently, other PP2C, HAB1/PP2C-HA and AHG3, have been shown to negatively regulate guard cell responses to ABA (Leonhardt et al. 2004; Saez et al. 2004; Kuhn et al. 2006; Robert et al. 2006). Additive effects of inactivation of multiple PP2Cs indicate that they cooperate to negatively regulate ABA signaling in guard cells (Merlot et al. 2001; Saez et al. 2006). Interestingly, PYR-PYL/RCAR ABA receptors physically interact with HAB1, ABI1 and ABI2 PP2C in the presence of ABA

and down regulate their activity (Ma et al. 2009; Park et al. 2009).

Biochemical studies, mutant screen based on thermal imaging of leaves and reverse genetics have identified *Arabidopsis* OST1/Srk2e/SnRK2-6 and its *Vicia faba* orthologue AAPK as a major positive regulator in ABA signal transduction in guard cells (Li and Assmann 1996; Mori and Muto 1997; Li et al. 2000; Mustilli et al. 2002; Yoshida et al. 2002). OST1 is a SnRK2 type protein kinase activated by ABA and *ost1* mutant stomata are insensitive to ABA. Mass spectrometric and mutational analyses have revealed several phosphorylation sites important for OST1 activity in guard cells (Belin et al. 2006; Boudsocq et al. 2007). Interaction and truncation studies indicate a regulatory function of the C-terminal domain of OST1 and its involvement in the binding of ABI1 phosphatase (Belin et al. 2006; Yoshida et al. 2006). AKIP1, an RNA binding protein, was identified as a direct target of AAPK in *Vicia faba* guard cells (Li et al. 2002). In contrast, in *Arabidopsis*, the AKIP homologue, UBA2, relocalizes to nuclear speckles in response to ABA independently of OST1 phosphorylation (Riera et al. 2006).

Reverse genetic studies have revealed the involvement of other kinases and phosphatases in the control of stomatal responses to ABA. SnRK3 type kinases are involved in the negative control of ABA sensitivity in guard cells. Inactivation of PKS3 SnRK3 kinase or of its interacting calcium binding protein ScaBP5 results in ABA hypersensitivity of stomatal closure (Guo et al. 2002; Kim et al. 2003). A recent report demonstrated that two calcium dependent kinases, CPK3 and CPK6, function as positive regulators of ABA signaling in guard cells. Combined inactivation of *CPK3* and *CPK6* genes results in a reduction in ABA and  $\text{Ca}^{2+}$  activation of S-type anion channels, in impairment in ABA activation of  $\text{Ca}^{2+}$  permeable channels and in a decreased ABA sensitivity of stomatal closure (Mori et al. 2006). In addition, stomatal movements and slow anion channels are sensitive to inhibitors of protein phosphatases type 1 and 2A (Schmidt et al. 1995; Grabov et al. 1997; Pei et al. 1997). Disruption of RCN1, a PP2A regulatory subunit, leads to a reduction of ABA activation of anion channels and ABA-induced stomatal closing (Kwak et al. 2002). Finally, MAP kinases also function in

ABA signaling. Targeted silencing of the *MPK3* gene in guard cells decreases stomatal closure triggered by ABA and reactive oxygen species (Gudesblat et al. 2007).

### 1.3 Intracellular Calcium

ABA triggers a rapid increase in cytosolic free calcium  $[\text{Ca}]_i$  (McAinsh et al. 1990). Furthermore, experimentally imposing  $[\text{Ca}]_i$  increases induced stomatal closure (Gilroy et al. 1990; Allen et al. 2001). Abscisic acid activates a hyperpolarization-dependent  $\text{Ca}^{2+}$  permeable conductance in *Vicia faba* and *Arabidopsis thaliana* guard cells (Hamilton et al. 2000; Pei et al. 2000; Murata et al. 2001). This  $\text{Ca}^{2+}$  conductance activated by reactive oxygen species (ROS) in *Arabidopsis thaliana*, is modulated by phosphorylation in *Vicia faba* and ABA activation is disrupted in the *abi1-1* and *abi2-1* mutants (Pei et al. 2000; Murata et al. 2001; Kohler and Blatt 2002).

Calcium release from internal stores also contributes to ABA-induced  $[\text{Ca}]_i$  elevation. Intracellular signals triggered by ABA, such as cADPR, phosphoinositides (IP3/IP6) and NO, activate endomembrane  $\text{Ca}^{2+}$  release pathways (Allen and Sanders 1994; Staxen et al. 1999; MacRobbie 2000; Garcia-Mata et al. 2003; Lemtiri-Chlieh et al. 2003).

A number of studies have shown that ABA does not generally cause detectable increases in cytosolic  $\text{Ca}^{2+}$  (Schroeder and Hagiwara 1990; Gilroy et al. 1991; Allan et al. 1994; Romano et al. 2000; Kwak et al. 2003; Levchenko et al. 2005; Marten et al. 2007). These findings have led to a model in which calcium-dependent mechanisms of stomatal closure are paralleled by a calcium-independent pathway. The relative contributions of ABA-induced  $\text{Ca}^{2+}$ -dependent and  $\text{Ca}^{2+}$ -independent stomatal closing pathways have recently been quantified and known mutations were shown to affect  $\text{Ca}^{2+}$ -dependent stomatal closing (Siegel et al. 2009).

Longer term recordings of  $[\text{Ca}^{2+}]_i$  have shown that ABA regulates repetitive  $\text{Ca}^{2+}$  transients in guard cells (Allen et al. 1999). Repetitive calcium transients are correlated with plasma membrane calcium permeable currents (Schroeder and Hagiwara 1990) and their maintenance requires PLC activity (Staxen et al. 1999). Application of sphingosine-1 phosphate is sufficient to trigger calcium oscillations in guard cells (Ng et al. 2001).



Analyses using experimentally imposed calcium transients showed that all imposed  $[Ca^{2+}]_i$  transients above a threshold amplitude are sufficient to induce a fast  $Ca^{2+}$  “reactive” stomatal closure response independent of the  $Ca^{2+}$  transient durations analyzed (Allen et al. 2001). Moreover, a defined range of  $Ca^{2+}$  oscillations is able to inhibit the re-opening of stomata state despite imposing stomatal opening stimuli, thus maintaining stomata in a long-term “programmed” closed state (Allen et al. 2001; Li et al. 2004).

Guard cells of the *gca2* mutant produce abnormal high frequency short calcium oscillations in response to ABA and elevated  $CO_2$  and display insensitivity to both stimuli (Allen et al. 2001; Young et al. 2006). These rapid  $Ca^{2+}$  spikes are likely due to hyperpolarized membrane potentials (Grabov and Blatt, 1998; Klusener et al. 2002; Young et al. 2006). This raises the question of why these  $[Ca^{2+}]_i$  spikes observed in the absence of a stomatal closing stimulus do not cause rapid  $Ca^{2+}$  reactive stomatal closing (Allen et al. 2001; Klusener et al. 2002; Young et al. 2006). A  $Ca^{2+}$  sensitivity priming hypothesis was proposed in which  $Ca^{2+}$  sensors are in an in-activated (de-primed) state and physiological stimuli would prime specific  $Ca^{2+}$  sensors (Israelsson et al. 2006; Young et al. 2006; Siegel et al. 2009).  $Ca^{2+}$  sensitivity priming could allow  $[Ca^{2+}]_i$  elevations to activate selectively specific downstream responses (Israelsson et al. 2006; Young et al. 2006). According to this hypothesis, stomatal closing stimuli, ABA and  $CO_2$ , prime  $Ca^{2+}$  sensors, so that they can respond to the prevailing  $[Ca^{2+}]_i$  elevations, thus allowing  $Ca^{2+}$  reactive stomatal closure. In agreement with this hypothesis, the ability of  $[Ca^{2+}]_i$  elevation to activate S-type anion channels and to down-regulate inward-rectifying  $K^+$  channel can be “turned on or off” depending on ABA pre-exposure and experimental conditions (Allen et al. 2002; Siegel et al. 2009).

#### 1.4 Reactive Oxygen Species and Redox Control

Redox control has emerged as a central component in guard cell signaling. Several studies have shown that ABA induces an increase in ROS formation in guard cells (Pei et al. 2000; Zhang et al. 2001). *Arabidopsis thaliana* NADPH oxidase *AtrbohD* and *F* have been shown to contribute to ABA induced ROS formation in guard cells and to function in ABA activation of ROS-induced  $Ca^{2+}$

channels (Kwak et al. 2003). Accordingly, ABA-induced stomatal closure is partially impaired in an *rbohD rbohF* double mutant. Direct application of  $H_2O_2$  induces stomatal closure (Allen et al. 2000; Pei et al. 2000; Zhang et al. 2001; Bright et al. 2006). ABA induced ROS formation impinges on a general redox control mediated by glutathione peroxidase and diurnal regulation of stomatal aperture mediated by ascorbic acid (Chen and Gallie 2004; Miao et al. 2006). ABA also induces the formation of nitric oxide (Neill et al. 2002). A recent report suggests that NO acts downstream of  $H_2O_2$  in ABA induced stomatal closure (Bright et al. 2006). In turn, NO controls a subset of ABA responses including the activation of cADPR controlled internal calcium release and  $K$  channels regulation (Garcia-Mata et al. 2003; Sokolovski and Blatt 2004).

#### 1.5 pH

ABA induces a rapid increase of guard cell cytosolic pH (Irving et al. 1992; Suhita et al. 2004). The mechanism responsible for the pH changes is not yet identified. Cytosolic alkalinization has been shown to up regulate outward  $K^+$  channels mediating potassium efflux from guard cells (Blatt and Armstrong 1993; Grabov and Blatt 1997). Activation of slow anion channels also involves a pH dependent component (Li et al. 2000).

#### 1.6 Lipid Derived Signaling Intermediates

ABA can trigger increases in several lipid derived second messengers: the phosphoinositides IP3 and IP6, phosphatidic acid and sphingosin-1-phosphate (Jacob et al. 1999; Staxen et al. 1999; Lemtiri-Chlieh et al. 2000; Ng et al. 2001; Coursol et al. 2003). Accordingly, inactivation of phospholipase C partially inhibits stomatal responses to ABA (Staxen et al. 1999; Hunt et al. 2003; Mills et al. 2004). PLC activity is required for ABA mediated calcium signaling and IP3 activates calcium permeable channels in the vacuolar membrane of guard cells (Allen and Sanders 1994). Moreover, IP6 mediates calcium release from internal stores and inhibits plasma membrane potassium inward channels (Lemtiri-Chlieh et al. 2000, 2003). In addition, specific disruption of *PLD $\alpha$ 1* blocks ABA induced stomatal closure and ABA mediated inhibition of stomatal opening (Sang et al. 2001; Zhang et al. 2004). *PLD $\alpha$ 1* initiates a bifurcating pathway targeting the

protein phosphatase 2C ABI1 and the G protein  $\alpha$  subunit GPA1 (Mishra et al. 2006). Accordingly, phosphatidic acid application on guard cells leads to stomatal closure (Jacob et al. 1999). Finally, ABA treatment leads to activation of sphingosine kinase, the enzyme responsible for the formation of sphingosine 1 phosphate (Coursol et al. 2003, 2005). S1P treatment is sufficient to trigger calcium oscillations in guard cells and induces stomatal closure (Ng et al. 2001; Coursol et al. 2003).

### 1.7 G Proteins

Pharmacological evidence first demonstrated the role of trimeric G proteins in ABA regulation of  $K^+$  inward currents (Fairley-Grenot and Assmann 1991). The *Arabidopsis thaliana* genome encodes only one G protein alpha subunit GPA1. In addition, the pharmacological data may be accounted for by the newly discovered GTG proteins which include a G protein domain (Pandey et al. 2009). Disruption of GPA1 leads to ABA insensitivity of stomatal closure and stomatal opening by preventing ABA inhibition of  $K_{in}$  currents and ABA activation of slow anion currents (Wang et al. 2001). GPA1 appears to interact with two G protein coupled membrane receptors GCR1 and GCR2 (Pandey and Assmann 2004; Liu et al. 2007). GCR1 receptor acts as a negative regulator of ABA signaling; *gcr1* mutant guard cells are hypersensitive to ABA (Pandey and Assmann 2004). Disruption of *GPA1* confers S1P insensitivity (Coursol et al. 2003) while disruption of *GCR1* confers S1P hypersensitivity (Pandey and Assmann 2004).

## 2 Guard Cell Signal Transduction Network

Abscisic acid signal transduction components assemble into a complex network (Hetherington and Woodward 2003; Israelsson et al. 2006). This network together with other specific signaling components allows guard cells to produce an integrated response to a variety of signals that modulate stomatal aperture, such as ABA, light,  $CO_2$ , apoplastic calcium, pathogen derived molecules and pollutants. Figure 3 provides a simplified model illustrating parallel signaling modules acting in  $Ca^{2+}$ -dependent and  $Ca^{2+}$ -independent pathways. Extensive reconstruction of the ABA signal transduction network leading to stomatal

closure has already been described and used to design a model (Li et al. 2006).

In addition, mutant screens for altered ABA sensitivity have identified several genes coding for proteins involved in RNA metabolism and transcription factors (Kuhn and Schroeder 2003). Interestingly, RNA metabolism proteins, as well as ABA itself, may control the expression of ABA signal transduction components. For example, the negatively regulating PP2C, HAB1 / PP2C-HA, is strongly induced by ABA in guard cells (Leonhardt et al. 2004). Mutation in the *ABH1* gene encoding a nuclear RNA CAP binding protein down-regulates *PP2CA* expression (Hugouvieux et al. 2001). Such regulation may confer plasticity to the ABA transduction network to adapt to changing environmental conditions.

### 3 Other Stomatal Closing Stimuli Cross-Talk Through the Guard Cell Signaling Network

Many signals and stresses, such as ABA, light,  $CO_2$ , apoplastic calcium, pathogen derived molecules and pollutants influence stomatal aperture and need to cross talk through the guard cell signaling network. Here, we have selected external calcium and  $CO_2$  signaling pathways to illustrate the common and specific components used by different signals inducing stomatal closure.

#### 3.1 Extracellular Calcium

Increases in extracellular calcium trigger stomatal closure (McAinsh et al. 1995). Extracellular calcium may act as signal allowing guard cells to monitor transpiration flux as it accumulates in the cell wall when the transpiration rate is decreased (Tang et al. 2007). Recently, a plastidial  $Ca^{2+}$  sensor, CAS1, has been identified (Han et al. 2003; Nomura et al. 2008; Weinl et al. 2008). Inactivation of CAS1 results in stomatal insensitivity to extracellular  $Ca^{2+}$ . Recent work suggests that extracellular calcium contributes to mediation of diurnal calcium oscillations by stimulating phosphoinositide turnover (Tang et al. 2007). External calcium triggers  $[Ca^{2+}]_i$  oscillations with dose dependent duration and frequencies (McAinsh et al. 1995). In contrast, in the *det3* mutant, which is impaired in V-type proton ATPase activity, external calcium application generates long lasting  $[Ca^{2+}]_i$  elevation (Allen et al. 2000). Interestingly, ABA-induced calcium oscillations and stomatal closure are not altered in *det3*. Moreover, in *tpc1*

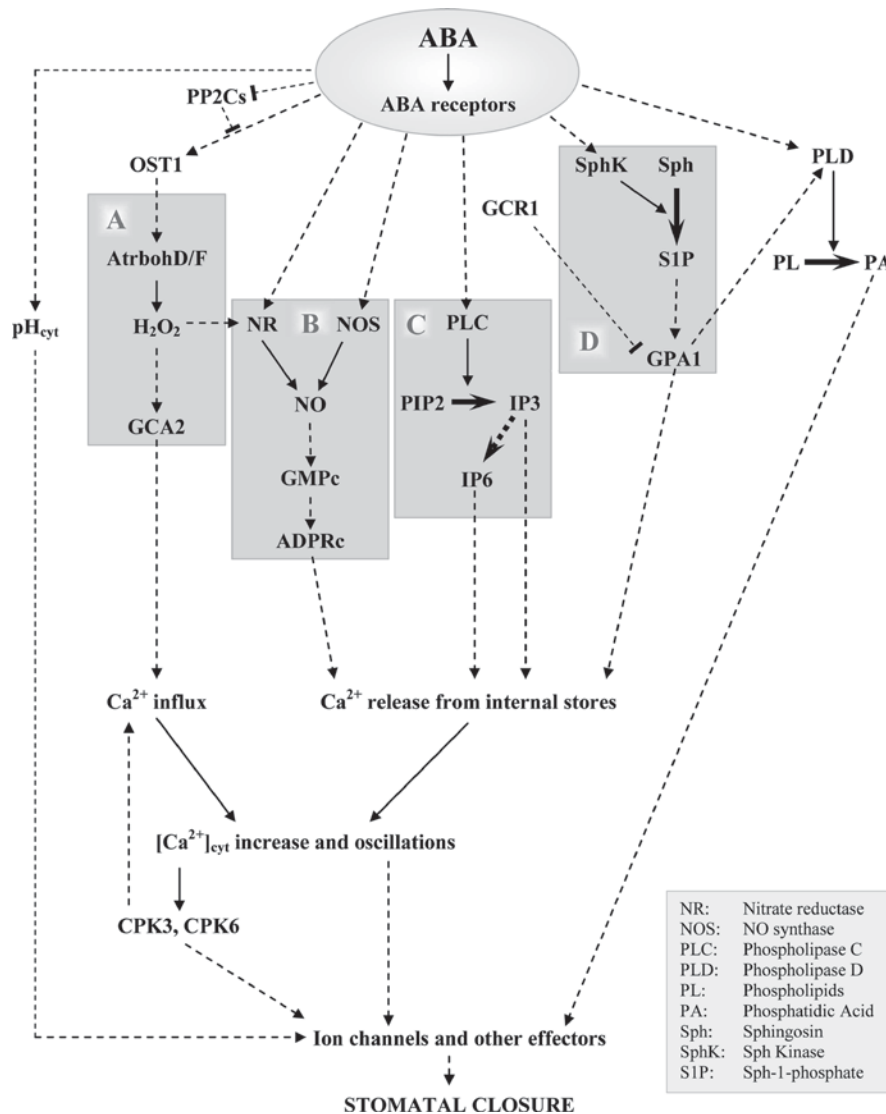

Fig. 3. The network of “signaling modules” as a model of ABA signaling pathway. This figure illustrates a simplified modular view of ABA signaling. All dashed lines in this model represent interactions between ABA perception, the proposed modules (boxes A–D), and other components described in the pathway and the effectors of the response.

knockout mutant lacking slow vacuolar currents, stomatal response to external calcium is impaired (Peiter et al. 2005). Extracellular calcium thus shares some transduction components, such as calcium oscillations and phosphoinositides with ABA, while it uses an apparent specific perception system (CAS1) and a separate pathway to generate intracellular calcium signals.

### 3.2 Carbon Dioxide Signaling

Stomata need to adjust their aperture with changing atmospheric CO<sub>2</sub> partial pressure to optimize

photosynthesis efficiency. An increase in pCO<sub>2</sub> induces a reduction in stomatal aperture (Morrison 1985). This response is associated with intracellular calcium increases (Webb et al. 1996; Young et al. 2006). Interestingly, the *gca2* mutation impairs both high CO<sub>2</sub>- and ABA-induced stomatal closure (Allen et al. 2001; Young et al. 2006). In contrast, *ost1*, *abi1* and *abi2* mutants that fail to close in response to ABA remain sensitive to pCO<sub>2</sub> increases (Leymarie et al. 1998; Mustilli et al. 2002). A genetic screen for mutations

altering guard cell sensitivity identified a novel protein kinase, HT1, which specifically controls stomatal movements in response to CO<sub>2</sub>, but not blue light or ABA responses (Hashimoto et al. 2006). Strong recessive *ht1* mutations cause a constitutive high CO<sub>2</sub> response, showing that the HT1 kinase is a central negative regulator of CO<sub>2</sub>-induced stomatal closing (Hashimoto et al. 2006).

Some signaling components are specific for a given signal while others are shared between several signals. However, each signal likely uses a unique combination of network components to produce an adapted response and to cross talk with other signals.

#### IV Genes and Promoters of Interest to Manipulate Stomatal Function in Crop Plants

Stomatal closure in response to alteration of plant water balance in the roots or in the leaves represents one of the earliest responses to drought. As it prevents further alterations of water balance, stomatal closure represents a drought avoidance response. Compared to drought resistance involving the synthesis of osmolytes, such as proline or stress tolerance proteins (Seki et al. 2007), drought avoidance through closure of stomata is energetically cost effective for the plant and reversible. In case of prolonged acute drought, stomatal closure may not be sufficient to ensure plant survival, but transitory drought periods that typically cause agricultural losses could be ameliorated through stomatal engineering (Schroeder et al. 2001a, b).

Abscisic acid hypersensitivity leads to improved drought avoidance while ABA insensitivity leads to increased sensitivity to drought periods resulting in wilting and leaf death. ABA exerts control on both stomatal closure and general drought resistance mechanisms (Seki et al. 2007). To specifically alter stomatal movements, it would be essential to target effectors specifically to the guard cells using appropriate promoters. For example, the promoters of the *KATI* and *OST1* genes, which are specifically expressed in guard cells, represent useful tools to target such specific expression (Nakamura et al. 1995; Mustilli et al. 2002; Belin et al. 2006), but the

*KATI* promoter is relatively weak. A strong guard cell promoter was identified by transcriptomic studies comparing gene expression in guard cells, mesophyll cells and other tissues at the genomic scale (Leonhardt et al. 2004; Yang et al. 2008). In addition to guard cell-targeted expression, it is also advantageous to target ABA regulated expression. Such regulation would allow increased drought tolerance after a first exposure to drought stress or tunable expression as drought stress increases.

The work summarized in the previous parts of this chapter has identified numerous genes that may be useful to engineer stomatal movements. Mutations in negative regulators of ABA guard cell response, such as ABH1 or ERA1, confer ABA hypersensitivity and increased drought avoidance in *Arabidopsis* (Pei et al. 1998; Hugouvieux et al. 2001). Conditional inactivation of *ERA1* by RNAi under the control of drought induced *rd29A* promoter was shown to improve canola plant tolerance to drought without any decrease in yield under well watered conditions (Wang et al. 2005). This study provides a proof of concept that drought tolerance in field crops may be achieved through manipulating ABA signaling.

#### V Conclusions

Stomata form a crucial interface between plants and the atmosphere and are essential to the control of water balance in plants. Stomata represent a putative target to engineer drought avoidance in plants with minimal alterations of yield. Guard cells have been developed as an excellent model to analyze transduction networks and a good candidate system for testing quantitative and predictive modeling of signal transduction. Many components have already been identified. In the future, it will be essential to evaluate quantitatively the relative contribution of each component under different environmental conditions. This should allow determination of key targets in a given environment as well as the identification of components that are specific to one signal, such as HT1 for CO<sub>2</sub> or OST1 for ABA (Mustilli et al. 2002; Hashimoto et al. 2006). In addition it will be important to determine at the molecular level how the components of the network interact with each other and further identify unknown players in this network.



## Acknowledgements

Research in the author's laboratories was supported by the Centre National de la Recherche Scientifique (CB and ST), a PhD fellowship from the Ministère de la Recherche et des Nouvelles Technologies to CB and National Institutes of Health (R01GM060396), National Science Foundation (MCB 0417118-0918220) and Department of Energy (DE-FG02-03ER15449) grants to J.I.S.

## References

- Ache P, Becker D, Ivashikina N, Dietrich P, Roelfsema MR, Hedrich R (2000) GORK, a delayed outward rectifier expressed in guard cells of *Arabidopsis thaliana*, is a K<sup>+</sup>-selective, K<sup>+</sup>-sensing ion channel. *FEBS Lett* 486:93–98
- Allan AC, Fricker MD, Ward JL, Beale MH, Trewavas AJ (1994) Two transduction pathways mediate rapid effects of abscisic acid in *Commelina* guard cells. *Plant Cell* 6:1319–1328
- Allen GJ, Sanders D (1994) Two voltage-gated, calcium release channels co reside in the vacuolar membrane of broad bean guard cells. *Plant Cell* 6:685–694
- Allen GJ, Sanders D (1996) Control of ionic currents in guard cell vacuoles by cytosolic and luminal calcium. *Plant J* 10:1055–1069
- Allen GJ, Kuchitsu K, Chu SP, Murata Y, Schroeder JI (1999) *Arabidopsis* *abi1-1* and *abi2-1* phosphatase mutations reduce abscisic acid-induced cytoplasmic calcium rises in guard cells. *Plant Cell* 11:1785–1798
- Allen GJ, Chu SP, Schumacher K, Shimazaki CT, Vafeados D, Kemper A, Hawke SD, Tallman G, Tsien RY, Harper JF, Chory J, Schroeder JI (2000) Alteration of stimulus-specific guard cell calcium oscillations and stomatal closing in *Arabidopsis det3* mutant. *Science* 289:2338–2342
- Allen GJ, Chu SP, Harrington CL, Schumacher K, Hoffmann T, Tang YY, Grill E, Schroeder JI (2001) A defined range of guard cell calcium oscillation parameters encodes stomatal movements. *Nature* 411:1053–1057
- Allen GJ, Murata Y, Chu SP, Nafisi M, Schroeder JI (2002) Hypersensitivity of abscisic acid-induced cytosolic calcium increases in the *Arabidopsis* farnesyl transferase mutant *era1-2*. *Plant Cell* 14:1649–1662
- Anderson JA, Huprikar SS, Kochian LV, Lucas WJ, Gaber RF (1992) Functional expression of a probable *Arabidopsis thaliana* potassium channel in *Saccharomyces cerevisiae*. *Proc Natl Acad Sci USA* 89:3736–3740
- Artsaenko O, Peisker M, zur Nieden U, Fiedler U, Weiler EW, Muntz K, Conrad U (1995) Expression of a single-chain Fv antibody against abscisic acid creates a wilted phenotype in transgenic tobacco. *Plant J* 8:745–750
- Assmann SM, Simoncini L, Schroeder JI (1985) Blue light activates electrogenic ion pumping in guard cell protoplasts of *Vicia faba*. *Nature* 318:285–287
- Assmann SM, Snyder JA, Lee YRJ (2000) ABA-deficient (*aba1*) and ABA-insensitive (*abi1-1*, *abi2-1*) mutants of *Arabidopsis* have a wild-type stomatal response to humidity. *Plant Cell Environ* 23:387–395
- Barrero JM, Rodriguez PL, Quesada V, Piqueras P, Ponce MR, Micol JL (2006) Both abscisic acid (ABA)-dependent and ABA-independent pathways govern the induction of NCED3, AAO3 and ABA1 in response to salt stress. *Plant Cell Environ* 29:2000–2008
- Barton MK (2007) Making holes in leaves: promoting cell state transitions in stomatal development. *Plant Cell* 19:1140–1143
- Belin C, de Franco PO, Bourbousse C, Chaignepain S, Schmitter JM, Vavasseur A, Giraudat J, Barbier-Brygoo H, Thomine S (2006) Identification of features regulating OST1 kinase activity and OST1 function in guard cells. *Plant Physiol* 141:1316–1327
- Bergmann DC, Sack FD (2007) Stomatal development. *Annu Rev Plant Biol* 58:163–181
- Blatt MR, Armstrong F (1993) K<sup>+</sup> channels of stomatal guard cells: abscisic-acid evoked control of the outward rectifier mediated by cytoplasmic pH. *Planta* 191:330–341
- Boudsocq M, Droillard MJ, Barbier-Brygoo H, Lauriere C (2007) Different phosphorylation mechanisms are involved in the activation of sucrose non-fermenting 1 related protein kinases 2 by osmotic stresses and abscisic acid. *Plant Mol Biol* 63:491–503
- Bright J, Desikan R, Hancock JT, Weir IS, Neill SJ (2006) ABA-induced NO generation and stomatal closure in *Arabidopsis* are dependent on H<sub>2</sub>O<sub>2</sub> synthesis. *Plant J* 45:113–122
- Buckley TN (2005) The control of stomata by water balance. *New Phytol* 168:275–292
- Chen Z, Gallie DR (2004) The ascorbic acid redox state controls guard cell signaling and stomatal movement. *Plant Cell* 16:1143–1162
- Christmann A, Hoffmann T, Teplova I, Grill E, Muller A (2005) Generation of active pools of abscisic acid revealed by in vivo imaging of water-stressed *Arabidopsis*. *Plant Physiol* 137:209–219
- Christmann A, Weiler EW, Steudle E, Grill E (2007) A hydraulic signal in root-to-shoot signalling of water shortage. *Plant J* 52:167–174
- Coursol S, Fan LM, Le Stunff H, Spiegel S, Gilroy S, Assmann SM (2003) Sphingolipid signalling in *Arabidopsis* guard cells involves heterotrimeric G proteins. *Nature* 423:651–654
- Coursol S, Le Stunff H, Lynch DV, Gilroy S, Assmann SM, Spiegel S (2005) *Arabidopsis* sphingosine kinase and the effects of phytosphingosine-1-phosphate on stomatal aperture. *Plant Physiol* 137:724–737
- Daeter W, Hartung W (1995) Stress-dependent redistribution of abscisic acid (ABA) in *Hordeum vulgare* L. leaves: the

- role of epidermal ABA metabolism, tonoplastic transport and the cuticle. *Plant Cell Environ* 18:1367–1376
- Davies WJ, Wilkinson S, Loveys B (2002) Stomatal control by chemical signalling and the exploitation of this mechanism to increase water use efficiency in agriculture. *New Phytol* 153:449–460
- Du Z, Aghoram K, Outlaw WH Jr (1997) In vivo phosphorylation of phosphoenolpyruvate carboxylase in guard cells of *Vicia faba* L. is enhanced by fusicoccin and suppressed by abscisic acid. *Arch Biochem Biophys* 337:345–350
- Eun SO, Bae SH, Lee Y (2001) Cortical actin filaments in guard cells respond differently to abscisic acid in wild-type and *abi1-1* mutant in *Arabidopsis*. *Planta* 212:466–469
- Fairley-Grenot K, Assmann SM (1991) Evidence for G-protein regulation of inward  $K^+$  channel current in guard cells of fava bean. *Plant Cell* 3:1037–1044
- Fischer RA (1968) Stomatal opening: role of potassium uptake by guard cells. *Science* 160:784–785
- Franks PJ, Cowan IR, Farquhar GD (1998) A study of stomatal mechanics using the cell pressure probe. *Plant Cell Environ* 21:94–100
- Gao XQ, Li CG, Wei PC, Zhang XY, Chen J, Wang XC (2005) The dynamic changes of tonoplasts in guard cells are important for stomatal movement in *Vicia faba*. *Plant Physiol* 139:1207–1216
- Gao Y, Zeng Q, Guo J, Cheng J, Ellis BE, Chen JG (2007) Genetic characterization reveals no role for the reported ABA receptor, GCR2, in ABA control of seed germination and early seedling development in *Arabidopsis*. *Plant J* 52:1001–1013
- Garcia-Mata C, Gay R, Sokolovski S, Hills A, Lamattina L, Blatt MR (2003) Nitric oxide regulates  $K^+$  and  $Cl^-$  channels in guard cells through a subset of abscisic acid-evoked signaling pathways. *Proc Natl Acad Sci USA* 100:11116–11121
- Gilroy S, Read ND, Trewavas AJ (1990) Elevation of cytoplasmic calcium by caged calcium or caged inositol triphosphate initiates stomatal closure. *Nature* 346:769–771
- Gilroy S, Fricker MD, Read ND, Trewavas AJ (1991) Role of calcium in signal transduction of *Commelina* guard cells. *Plant Cell* 3:333–344
- Gobert A, Isayenkov S, Voelker C, Czempinski K, Maathuis FJ (2007) The two-pore channel *TPK1* gene encodes the vacuolar  $K^+$  conductance and plays a role in  $K^+$  homeostasis. *Proc Natl Acad Sci USA* 104:10726–10731
- Goh CH, Kinoshita T, Oku T, Shimazaki K (1996) Inhibition of blue light-dependent  $H^+$  pumping by abscisic acid in *Vicia* guard-cell protoplasts. *Plant Physiol* 111:433–440
- Gollan T, Schurr U, Schulze, E.D. (1992) Stomatal response to drying soil in relation to changes in the xylem sap composition of *Helianthus annuus*. I. The concentration of cations, anions, amino acids in, and pH of the xylem sap. *Plant Cell Environ*. 15:551–559
- Gosti F, Beaudoin N, Serizet C, Webb AA, Vartanian N, Giraudat J (1999) ABI1 protein phosphatase 2C is a negative regulator of abscisic acid signaling. *Plant Cell* 11:1897–1910
- Gowing DJG, Davies WJ, Jones HG (1990) A positive root-sourced signal as an indicator of soil drying in apple, *Malus X domestica* Borkh. *J Exp Bot* 41:1535–1540
- Gowing DJG, Jones HG, Davies WJ (1993) Xylem-transported abscisic acid: the relative importance of its mass and its concentration in the control of stomatal aperture. *Plant Cell Environ* 16:453–459
- Grabov A, Blatt MR (1997) Parallel control of the inward-rectifier  $K^+$  channel by cytosolic free  $Ca^{2+}$  and pH in *Vicia* guard cells. *Planta* 201:84–95
- Grabov A, Blatt MR. (1998) Membrane voltage initiates  $Ca^{2+}$  waves and potentiates  $Ca^{2+}$  increases with abscisic acid in stomatal guard cells. *Proc Natl Acad Sci U S A* 95:4778–4783
- Grabov A, Blatt MR (1999) A steep dependence of inward-rectifying potassium channels on cytosolic free calcium concentration increase evoked by hyperpolarization in guard cells. *Plant Physiol* 119:277–288
- Grabov A, Leung J, Giraudat J, Blatt MR (1997) Alteration of anion channel kinetics in wild-type and *abi1-1* transgenic *Nicotiana benthamiana* guard cells by abscisic acid. *Plant J* 12:203–213
- Gray JE (2007) Plant development: three steps for stomata. *Curr Biol* 17:R213–215
- Gray JE, Holroyd GH, van der Lee FM, Bahrami AR, Sijmons PC, Woodward FI, Schuch W, Hetherington AM (2000) The HIC signalling pathway links  $CO_2$  perception to stomatal development. *Nature* 408:713–716
- Gudesblat GE, Iusem ND, Morris PC (2007) Guard cell-specific inhibition of *Arabidopsis* MPK3 expression causes abnormal stomatal responses to abscisic acid and hydrogen peroxide. *New Phytol* 173:713–721
- Guo J, Zeng Q, Emami M, Ellis BE, Chen JG (2008) The GCR2 gene family is not required for ABA control of seed germination and early seedling development in *Arabidopsis*. *PLoS ONE* 3:e2982
- Guo Y, Xiong L, Song CP, Gong D, Halfter U, Zhu JK (2002) A calcium sensor and its interacting protein kinase are global regulators of abscisic acid signaling in *Arabidopsis*. *Dev Cell* 3:233–244
- Hafke JB, Hafke Y, Smith JA, Luttge U, Thiel G (2003) Vacuolar malate uptake is mediated by an anion-selective inward rectifier. *Plant J* 35:116–128
- Hamilton DW, Hills A, Kohler B, Blatt MR (2000)  $Ca^{2+}$  channels at the plasma membrane of stomatal guard cells are activated by hyperpolarization and abscisic acid. *Proc Natl Acad Sci USA* 97:4967–4972
- Han S, Tang R, Anderson LK, Woerner TE, Pei ZM (2003) A cell surface receptor mediates extracellular  $Ca^{2+}$  sensing in guard cells. *Nature* 425:196–200
- Hartung, W, Radin, J.W. (1989) Abscisic acid in the mesophyll apoplast and in the root xylem sap of water-stressed plants: the significance of pH gradients. *Curr Top Plant Biochem Physiol* 8:110–124

- Hashimoto M, Negi J, Young J, Israelsson M, Schroeder JI, Iba K (2006) *Arabidopsis* HT1 kinase controls stomatal movements in response to CO<sub>2</sub>. *Nat Cell Biol* 8:391–397
- Hedrich R, Neher E (1987) Cytoplasmic calcium regulates voltage-dependent ion channels in plant vacuoles. *Nature* 329:833–836
- Hetherington AM, Woodward FI (2003) The role of stomata in sensing and driving environmental change. *Nature* 424:901–908
- Hosy E, Vavasseur A, Mouline K, Dreyer I, Gaymard F, Poree F, Boucherez J, Lebaudy A, Bouchez D, Very AA, Simonneau T, Thibaud JB, Sentenac H (2003) The *Arabidopsis* outward K<sup>+</sup> channel GORK is involved in regulation of stomatal movements and plant transpiration. *Proc Natl Acad Sci USA* 100:5549–5554
- Hugouvieux V, Kwak JM, Schroeder JI (2001) An mRNA cap binding protein, ABH1, modulates early abscisic acid signal transduction in *Arabidopsis*. *Cell* 106:477–487
- Humble GD, Raschke K (1971) Stomatal opening quantitatively related to potassium transport: evidence from electron probe analysis. *Plant Physiol* 48:447–453
- Hunt L, Mills LN, Pical C, Leckie CP, Aitken FL, Kopka J, Mueller-Roeber B, McAinsh MR, Hetherington AM, Gray JE (2003) Phospholipase C is required for the control of stomatal aperture by ABA. *Plant J* 34:47–55
- Hurst AC, Meckel T, Tayefeh S, Thiel G, Homann U (2004) Trafficking of the plant potassium inward rectifier KAT1 in guard cell protoplasts of *Vicia faba*. *Plant J* 37:391–397
- Incoll, L.D, Jewer, P.C. (1987) Cytokinins and stomata. In Zeiger, E., Farquhar, G.D. and Cowan, I.R. (eds.), Stomatal function. Stanford University Press, Stanford, Calif
- Irving HR, Gehring CA, Parish RW (1992) Changes in cytosolic pH and calcium of guard cells precede stomatal movements. *Proc Natl Acad Sci USA* 89:1790–1794
- Israelsson M, Siegel RS, Young J, Hashimoto M, Iba K, Schroeder JI (2006) Guard cell ABA and CO<sub>2</sub> signaling network updates and Ca<sup>2+</sup> sensor priming hypothesis. *Curr Opin Plant Biol* 9:654–663
- Iuchi S, Kobayashi M, Taji T, Naramoto M, Seki M, Kato T, Tabata S, Kakubari Y, Yamaguchi-Shinozaki K, Shinozaki K (2001) Regulation of drought tolerance by gene manipulation of 9-cis-epoxycarotenoid dioxygenase, a key enzyme in abscisic acid biosynthesis in *Arabidopsis*. *Plant J* 27:325–333
- Jacob T, Ritchie S, Assmann SM, Gilroy S (1999) Abscisic acid signal transduction in guard cells is mediated by phospholipase D activity. *Proc Natl Acad Sci USA* 96:12192–12197
- Jahn R, Sudhof TC (1999) Membrane fusion and exocytosis. *Annu Rev Biochem* 68:863–911
- Jia W, Zhang J (1997) Comparison of exportation and metabolism of xylem-delivered ABA in maize leaves at different water status and xylem sap pH. *Plant Growth Regul* 21:43–49
- Keller BU, Hedrich R, Raschke K (1989) Voltage-dependent anion channels in the plasma membrane of guard cells. *Nature* 341:450–453
- Kim KN, Cheong YH, Grant JJ, Pandey GK, Luan S (2003) CIPK3, a calcium sensor-associated protein kinase that regulates abscisic acid and cold signal transduction in *Arabidopsis*. *Plant Cell* 15:411–423
- Klusener B, Young JJ, Murata Y, Allen GJ, Mori IC, Hugouvieux V, Schroeder JI (2002) Convergence of calcium signaling pathways of pathogenic elicitors and abscisic acid in *Arabidopsis* guard cells. *Plant Physiol* 130:2152–2163
- Kohler B, Blatt MR (2002) Protein phosphorylation activates the guard cell Ca<sup>2+</sup> channel and is a prerequisite for gating by abscisic acid. *Plant J* 32:185–194
- Koornneef M, Jorna ML, Brinkhorst-van der Swan DLC, Karssen CM (1982) The isolation of abscisic acid (ABA) deficient mutants by selection of induced revertants in non-germinating gibberellin sensitive lines of *Arabidopsis thaliana* (L.) Heynh. *Theor Appl Genet* 61:385–393
- Koornneef M, Reuling G, Karssen CM (1984) The isolation and characterization of abscisic acid-insensitive mutants of *Arabidopsis thaliana*. *Physiol Plantarum* 61:377–383
- Kuhn JM, Schroeder JI (2003) Impacts of altered RNA metabolism on abscisic acid signaling. *Curr Opin Plant Biol* 6:463–469
- Kuhn JM, Boisson-Dernier A, Dizon MB, Maktabi MH, Schroeder JI (2006) The protein phosphatase AtPP2CA negatively regulates abscisic acid signal transduction in *Arabidopsis*, and effects of *abh1* on AtPP2CA mRNA. *Plant Physiol* 140:127–139
- Kushiro T, Okamoto M, Nakabayashi K, Yamagishi K, Kitamura S, Asami T, Hirai N, Koshiba T, Kamiya Y, Nambara E (2004) The *Arabidopsis* cytochrome P450 CYP707A encodes ABA 8'-hydroxylases: key enzymes in ABA catabolism. *EMBO J* 23:1647–1656
- Kwak JM, Moon JH, Murata Y, Kuchitsu K, Leonhardt N, DeLong A, Schroeder JI (2002) Disruption of a guard cell-expressed protein phosphatase 2A regulatory subunit, RCN1, confers abscisic acid insensitivity in *Arabidopsis*. *Plant Cell* 14:2849–2861
- Kwak JM, Mori IC, Pei ZM, Leonhardt N, Torres MA, Dangel JL, Bloom RE, Bodde S, Jones JD, Schroeder JI (2003) NADPH oxidase *AtrbohD* and *AtrbohF* genes function in ROS-dependent ABA signaling in *Arabidopsis*. *EMBO J* 22:2623–2633
- Lahav M, Abu-Abied M, Belausov E, Schwartz A, Sadot E (2004) Microtubules of guard cells are light sensitive. *Plant Cell Physiol* 45:573–582
- Lee KH, Piao HL, Kim HY, Choi SM, Jiang F, Hartung W, Hwang I, Kwak JM, Lee IJ, Hwang I (2006) Activation of glucosidase via stress-induced polymerization rapidly increases active pools of abscisic acid. *Cell* 126:1109–1120
- Lemichez E, Wu Y, Sanchez JP, Mettouchi A, Mathur J, Chua NH (2001) Inactivation of AtRac1 by abscisic acid is essential for stomatal closure. *Genes Dev* 15:1808–1816

- Lentiri-Chlieh F, MacRobbie EA, Brearley CA (2000) Inositol hexakisphosphate is a physiological signal regulating the K<sup>+</sup>-inward rectifying conductance in guard cells. *Proc Natl Acad Sci USA* 97:8687–8692
- Lentiri-Chlieh F, MacRobbie EA, Webb AA, Manison NF, Brownlee C, Skepper JN, Chen J, Prestwich GD, Brearley CA (2003) Inositol hexakisphosphate mobilizes an endomembrane store of calcium in guard cells. *Proc Natl Acad Sci USA* 100:10091–10095
- Leon-Kloosterziel KM, Gil MA, Ruijs GJ, Jacobsen SE, Olszewski NE, Schwartz SH, Zeevaart JA, Koornneef M (1996) Isolation and characterization of abscisic acid-deficient *Arabidopsis* mutants at two new loci. *Plant J* 10:655–661
- Leonhardt N, Vavasseur A, Forestier C (1999) ATP binding cassette modulators control abscisic acid-regulated slow anion channels in guard cells. *Plant Cell* 11:1141–1152
- Leonhardt N, Kwak JM, Robert N, Waner D, Leonhardt G, Schroeder JI (2004) Microarray expression analyses of *Arabidopsis* guard cells and isolation of a recessive abscisic acid hypersensitive protein phosphatase 2C mutant. *Plant Cell* 16:596–615
- Leung J, Bouvier-Durand M, Morris PC, Guerrier D, Chefdor F, Giraudat J (1994) *Arabidopsis* ABA response gene ABI1: features of a calcium-modulated protein phosphatase. *Science* 264:1448–1452
- Leung J, Merlot S, Giraudat J (1997) The *Arabidopsis* abscisic acid-insensitive2 (ABI2) and ABI1 genes encode homologous protein phosphatases 2C involved in abscisic acid signal transduction. *Plant Cell* 9:759–771
- Levchenko V, Konrad KR, Dietrich P, Roelfsema MR, Hedrich R (2005) Cytosolic abscisic acid activates guard cell anion channels without preceding Ca<sup>2+</sup> signals. *Proc Natl Acad Sci USA* 102:4203–4208
- Leyman B, Geelen D, Quintero FJ, Blatt MR (1999) A tobacco syntaxin with a role in hormonal control of guard cell ion channels. *Science* 283:537–540
- Leymarie J, Vavasseur A, Lasceve G (1998) CO<sub>2</sub> sensing in stomata of *abi1-1* and *abi2-1* mutants of *Arabidopsis thaliana*. *Plant Physiology Biochem* 36:539–543
- Li J, Assmann SM (1996) An abscisic acid-activated and calcium-independent protein kinase from guard cells of fava bean. *Plant Cell* 8:2359–2368
- Li J, Wang XQ, Watson MB, Assmann SM (2000) Regulation of abscisic acid-induced stomatal closure and anion channels by guard cell AAPK kinase. *Science* 287:300–303
- Li J, Kinoshita T, Pandey S, Ng CK, Gygi SP, Shimazaki K, Assmann SM (2002) Modulation of an RNA-binding protein by abscisic-acid-activated protein kinase. *Nature* 418:793–797
- Li S, Assmann SM, Albert R (2006) Predicting essential components of signal transduction networks: a dynamic model of guard cell abscisic acid signaling. *PLoS Biol* 4:e312
- Li Y, Wang GX, Xin M, Yang HM, XJ W, Li T (2004) The parameters of guard cell calcium oscillation encodes stomatal oscillation and closure in *Vicia faba*. *Plant Sci* 166:415–421
- Liu X, Yue Y, Li B, Nie Y, Li W, Wu WH, Ma L (2007) A G-protein-coupled receptor is a plasma membrane receptor for the plant hormone abscisic acid. *Science* 315:1712–1716
- Ma Y, Szostkiewicz I, Korte A, Moes D, Yang Y, Christmann A, Grill E (2009) Regulators of PP2C phosphatase activity function as abscisic acid sensors. *Science* 324:1064–1068
- MacRobbie EAC (1983) Effects of light/dark on cation fluxes in guard cells of *Commelina communis* L. *J Exp Bot* 34:1695–1710
- MacRobbie EA (2000) ABA activates multiple calcium fluxes instrumental guard cells, triggering potassium (rubidium) release. *Proc Natl Acad Sci USA* 97:12362–12368
- MacRobbie EAC, Lettau J (1980) Ion content and aperture in ‘isolated’ guard cells of *Commelina communis* L. *J Memb Biol* 53:199–205
- Marin E, Nussaume L, Quesada A, Gonneau M, Sotta B, Huguency P, Frey A, Marion-Poll A (1996) Molecular identification of zeaxanthin epoxidase of *Nicotiana glauca*, a gene involved in abscisic acid biosynthesis and corresponding to the ABA locus of *Arabidopsis thaliana*. *EMBO J* 15:2331–2342
- Marten H, Konrad KR, Dietrich P, Roelfsema MR, Hedrich R (2007) Ca<sup>2+</sup>-dependent and -independent abscisic acid activation of plasma membrane anion channels in guard cells of *Nicotiana glauca*. *Plant Physiol* 143:28–37
- McAinsh MR, Brownlee C, Hetherington AM (1990) Abscisic acid-induced elevation of guard cell cytosolic Ca<sup>2+</sup> precedes stomatal closure. *Nature* 343:186–188
- McAinsh MR, Webb A, Taylor JE, Hetherington AM (1995) Stimulus-induced oscillations in guard cell cytosolic free calcium. *Plant Cell* 7:1207–1219
- Merlot S, Gosti F, Guerrier D, Vavasseur A, Giraudat J (2001) The ABI1 and ABI2 protein phosphatases 2C act in a negative feedback regulatory loop of the abscisic acid signalling pathway. *Plant J* 25:295–303
- Merlot S, Leonhardt N, Fenzi F, Valon C, Costa M, Piette L, Vavasseur A, Genty B, Boivin K, Muller A, Giraudat J, Leung J (2007) Constitutive activation of a plasma membrane H<sup>+</sup>-ATPase prevents abscisic acid-mediated stomatal closure. *EMBO J* 26:3216–3226
- Meyer K, Leube MP, Grill E (1994) A protein phosphatase 2C involved in ABA signal transduction in *Arabidopsis thaliana*. *Science* 264:1452–1455
- Miao Y, Lv D, Wang P, Wang XC, Chen J, Miao C, Song CP (2006) An *Arabidopsis* glutathione peroxidase functions as both a redox transducer and a scavenger in abscisic acid and drought stress responses. *Plant Cell* 18:2749–2766
- Mills LN, Hunt L, Leckie CP, Aitken FL, Wentworth M, McAinsh MR, Gray JE, Hetherington AM (2004) The effects of manipulating phospholipase C on guard cell ABA-signalling. *J Exp Bot* 55:199–204



- Mishra G, Zhang W, Deng F, Zhao J, Wang X (2006) A bifurcating pathway directs abscisic acid effects on stomatal closure and opening in *Arabidopsis*. *Science* 312:264–266
- Mori IC, Muto S (1997) Abscisic acid activates a 48 kilodalton protein kinase in guard cell protoplasts. *Plant Physiol* 113:833–839
- Mori IC, Murata Y, Yang Y, Munemasa S, Wang YF, Andreoli S, Tiriach H, Alonso JM, Harper JF, Ecker JR, Kwak JM, Schroeder JI (2006) CDPKs CPK6 and CPK3 function in ABA regulation of guard cell S-type anion- and Ca<sup>2+</sup>-permeable channels and stomatal closure. *PLoS Biol* 4:e327
- Morison JIL (1985) Sensitivity of stomata and water use efficiency to high CO<sub>2</sub>. *Plant Cell Environ* 8:467–474
- Murata Y, Pei ZM, Mori IC, Schroeder J (2001) Abscisic acid activation of plasma membrane Ca<sup>2+</sup> channels in guard cells requires cytosolic NAD(P)H and is differentially disrupted upstream and downstream of reactive oxygen species production in *abi1-1* and *abi2-1* protein phosphatase 2C mutants. *Plant Cell* 13:2513–2523
- Mustilli AC, Merlot S, Vavasseur A, Fenzi F, Giraudat J (2002) *Arabidopsis* OST1 protein kinase mediates the regulation of stomatal aperture by abscisic acid and acts upstream of reactive oxygen species production. *Plant Cell* 14:3089–3099
- Nakamura RL, McKendree WL, Hirsch RE, Sedbrook JC, Gaber RF, Sussman MR (1995) Expression of an *Arabidopsis* potassium channel gene in guard cells. *Plant Physiol* 109:371–374
- Nambara E, Marion-Poll A (2005) Abscisic acid biosynthesis and catabolism. *Annu Rev Plant Biol* 56:165–185
- Negi J, Matsuda O, Nagasawa T, Oba Y, Takahashi H, Kawai-Yamada M, Uchimiya H, Hashimoto M, Iba K (2008) CO<sub>2</sub> regulator SLAC1 and its homologues are essential for anion homeostasis in plant cells. *Nature* 452:483–486
- Neill SJ, Desikan R, Clarke A, Hancock JT (2002) Nitric oxide is a novel component of abscisic acid signaling in stomatal guard cells. *Plant Physiol* 128:13–16
- Ng CK, Carr K, McAinsh MR, Powell B, Hetherington AM (2001) Drought-induced guard cell signal transduction involves sphingosine-1-phosphate. *Nature* 410:596–599
- Nomura H, Komori T, Kobori M, Nakahira Y, Shiina T (2008) Evidence for chloroplast control of external Ca<sup>2+</sup>-induced cytosolic Ca<sup>2+</sup> transients and stomatal closure. *Plant J* 53:988–998
- Osakabe Y, Maruyama K, Seki M, Satou M, Shinozaki K, Yamaguchi-Shinozaki K (2005) Leucine-rich repeat receptor-like kinase 1 is a key membrane-bound regulator of abscisic acid early signaling in *Arabidopsis*. *Plant Cell* 17:1105–1119
- Pandey S, Assmann SM (2004) The *Arabidopsis* putative G protein-coupled receptor GCR1 interacts with the G-protein alpha subunit GPA1 and regulates abscisic acid signaling. *Plant Cell* 16:1616–1632
- Pandey S, Zhang W, Assmann SM (2007) Roles of ion channels and transporters in guard cell signal transduction. *FEBS Lett* 581:2325–2336
- Pandey S, Nelson DC, Assmann SM (2009) Two novel GPCR-type G proteins are abscisic acid receptors in *Arabidopsis*. *Cell* 136:136–148
- Park SY, Fung P, Nishimura N, Jensen DR, Fujii H, Zhao Y, Lumba S, Santiago J, Rodrigues A, Chow TF, Alfred SE, Bonetta D, Finkelstein R, Provart NJ, Desveaux D, Rodriguez PL, McCourt P, Zhu JK, Schroeder JI, Volkman BF, Cutler SR (2009) Abscisic acid inhibits type 2C protein phosphatases via the PYR/PYL family of START proteins. *Science* 324:1068–1071
- Pei ZM, Ward JM, Harper JF, Schroeder JI (1996) A novel chloride channel in *Vicia faba* guard cell vacuoles activated by the serine/threonine kinase, CDPK. *EMBO J* 15:6564–6574
- Pei ZM, Kuchitsu K, Ward JM, Schwarz M, Schroeder JI (1997) Differential abscisic acid regulation of guard cell slow anion channels in *Arabidopsis* wild-type and *abi1* and *abi2* mutants. *Plant Cell* 9:409–423
- Pei ZM, Ghassemian M, Kwak CM, McCourt P, Schroeder JI (1998) Role of farnesyl transferase in ABA regulation of guard cell anion channels and plant water loss. *Science* 282:287–290
- Pei ZM, Murata Y, Benning G, Thomine S, Klusener B, Allen GJ, Grill E, Schroeder JI (2000) Calcium channels activated by hydrogen peroxide mediate abscisic acid signalling in guard cells. *Nature* 406:731–734
- Peiter E, Maathuis FJM, Mills LN, Knight H, Pelloux J, Hetherington AM, Sanders D (2005) The vacuolar Ca<sup>2+</sup>-activated channel TPC1 regulates germination and stomatal movement. *Nature* 434:404–408
- Pilot G, Lacombe B, Gaymard F, Cherel I, Boucherez J, Thibaud JB, Sentenac H (2001) Guard cell inward K<sup>+</sup> channel activity in *Arabidopsis* involves expression of the twin channel subunits KAT1 and KAT2. *J Biol Chem* 276:3215–3221
- Radin, J.W., Parker, L.L., Guinn, G. (1982) Water relations of cotton plants under nitrogen deficiency. V. Environmental control of abscisic acid accumulation and stomatal sensitivity to abscisic acid. *Plant Physiol* 70:1066–1070
- Raschke K (1979) Movements of stomata. In: Hale W, Feinleib E (eds) *Encyclopedia of plant physiology*. Springer-Verlag, Berlin, pp 384–441
- Raschke K, Shabahang M, Wolf R (2003) The slow and the quick anion conductance in whole guard cells: their voltage-dependent alternation, and the modulation of their activities by abscisic acid and CO<sub>2</sub>. *Planta* 217:639–650
- Riera M, Redko Y, Leung J (2006) *Arabidopsis* RNA-binding protein UBA2a relocates into nuclear speckles in response to abscisic acid. *FEBS Lett* 580:4160–4165
- Ritte G, Rosenfeld J, Rohrig K, Raschke K (1999) Rates of sugar uptake by guard cell protoplasts of *Pisum sativum* L. Related to the solute requirement for stomatal opening. *Plant Physiol* 121:647–656

- Robert N, Merlot S, N'Guyen V, Boisson-Dernier A, Schroeder JI (2006) A hypermorphic mutation in the protein phosphatase 2C HAB1 strongly affects ABA signaling in *Arabidopsis*. FEBS Lett 580:4691–4696
- Roelfsema MR, Levchenko V, Hedrich R (2004) ABA depolarizes guard cells in intact plants, through a transient activation of R- and S-type anion channels. Plant J 37:578–588
- Romano LA, Jacob T, Gilroy S, Assmann SM (2000) Increases in cytosolic Ca<sup>2+</sup> are not required for abscisic acid inhibition of inward K<sup>+</sup> currents in guard cells of *Vicia faba*. Planta 11:309–317
- Saez A, Apostolova N, Gonzalez-Guzman M, Gonzalez-Garcia MP, Nicolas C, Lorenzo O, Rodriguez PL (2004) Gain-of-function and loss-of-function phenotypes of the protein phosphatase 2C HAB1 reveal its role as a negative regulator of abscisic acid signalling. Plant J 37:354–369
- Saez A, Robert N, Maktabi MH, Schroeder JI, Serrano R, Rodriguez PL (2006) Enhancement of abscisic acid sensitivity and reduction of water consumption in *Arabidopsis* by combined inactivation of the protein phosphatases type 2C ABI1 and HAB1. Plant Physiol 141:1389–1399
- Sang Y, Zheng S, Li W, Huang B, Wang X (2001) Regulation of plant water loss by manipulating the expression of phospholipase Da. Plant J 28:135–144
- Sauter A, Davies WJ, Hartung W (2001) The long-distance abscisic acid signal in the droughted plant: the fate of the hormone on its way from root to shoot. J Exp Bot 52:1991–1997
- Schachtman DP, Schroeder JI, Lucas WJ, Anderson JA, Gaber RF (1992) Expression of an inward-rectifying potassium channel by the *Arabidopsis* KAT1 cDNA. Science 258:1654–1658
- Schmidt C, Schelle I, Liao YJ, Schroeder JI (1995) Strong regulation of slow anion channels and abscisic acid signaling in guard cells by phosphorylation and dephosphorylation events. Proc Natl Acad Sci USA 92:9535–9539
- Scholz-Starke J, Gambale F, Carpaneto A (2005) Modulation of plant ion channels by oxidizing and reducing agents. Arch Biochem Biophys 434:43–50
- Schroeder JI, Hagiwara S (1989) Cytosolic calcium regulates ion channels in the plasma membrane of *Vicia faba* guard cells. Nature 338:427–430
- Schroeder JI, Hagiwara S (1990) Repetitive increases in cytosolic Ca<sup>2+</sup> of guard cells by abscisic acid activation of non-selective Ca<sup>2+</sup> permeable channels. Proc Natl Acad Sci USA 87:9305–9309
- Schroeder JI, Keller BU (1992) Two types of anion channel currents in guard cells with distinct voltage regulation. Proc Natl Acad Sci USA 89:5025–5029
- Schroeder JI, Raschke K, Neher E (1987) Voltage dependence of K<sup>+</sup> channels in guard-cell protoplasts. Proc Natl Acad Sci USA 84:4108–4112
- Schroeder JI, Allen GJ, Hugouvieux V, Kwak JM, Waner D (2001a) Guard cell signal transduction. Annu Rev Plant Physiol Plant Mol Biol 52:627–658
- Schroeder JI, Kwak JM, Allen GJ (2001b) Guard cell abscisic acid signalling and engineering drought hardiness in plants. Nature 410:327–330
- Seki M, Umezawa T, Urano K, Shinozaki K (2007) Regulatory metabolic networks in drought stress responses. Curr Opin Plant Biol 10:296–302
- Sentenac H, Bonneaud N, Minet M, Lacroute F, Salmon JM, Gaymard F, Grignon C (1992) Cloning and expression in yeast of a plant potassium ion transport system. Science 256:663–665
- Shen YY, Wang XF, Wu FQ, Du SY, Cao Z, Shang Y, Wang XL, Peng CC, Yu XC, Zhu SY, Fan RC, Xu YH, Zhang DP (2006) The Mg-chelatase H subunit is an abscisic acid receptor. Nature 443:823–826
- Shimazaki K, Iino M, Zeiger E (1986) Blue light-dependent proton extrusion by guard-cell protoplasts of *Vicia faba*. Nature 319:324–326
- Shinozaki K, Yamaguchi-Shinozaki K (1996) Molecular responses to drought and cold stress. Curr Opin Biotech 7:161–167
- Shope JC, DeWald DB, Mott KA (2003) Changes in surface area of intact guard cells are correlated with membrane internalization. Plant Physiol 133:1314–1321
- Siegel RS, Xue S, Murata Y, Yang Y, Nishimura N, Wang A, Schroeder JI. (2009) Calcium elevation-dependent and attenuated resting calcium-dependent abscisic acid induction of stomatal closure and abscisic acid-induced enhancement of calcium sensitivities of S-type anion and inward-rectifying K channels in *Arabidopsis* guard cells. Plant J. 59:207–220
- Sokolovski S, Blatt MR (2004) Nitric oxide block of outward-rectifying K<sup>+</sup> channels indicates direct control by protein nitrosylation in guard cells. Plant Physiol 136:4275–4284
- Stadler R, Buttner M, Ache P, Hedrich R, Ivashikina N, Melzer M, Shearson SM, Smith SM, Sauer N (2003) Diurnal and light-regulated expression of AtSTP1 in guard cells of *Arabidopsis*. Plant Physiol 133:528–537
- Staxen II, Pical C, Montgomery LT, Gray JE, Hetherington AM, McAinsh MR (1999) abscisic acid induces oscillations in guard-cell cytosolic free calcium that involve phosphoinositide-specific phospholipase C. Proc Natl Acad Sci USA 96:1779–1784
- Stoll, M., Loveys, B. and Dry, P. (2000) Hormonal changes induced by partial rootzone drying of irrigated grapevine. J Exp Bot 51:1627–1634
- Suh SJ, Wang YF, Frelet A, Leonhardt N, Klein M, Forestier C, Mueller-Roeber B, Cho MH, Martinoia E, Schroeder JI (2007) The ATP binding cassette transporter AtMRP5 modulates anion and calcium channel activities in *Arabidopsis* guard cells. J Biol Chem 282:1916–1924
- Suhita D, Raghavendra AS, Kwak JM, Vavasseur A (2004) Cytoplasmic alkalization precedes reactive oxygen species production during methyl jasmonate- and abscisic acid-induced stomatal closure. Plant Physiol 134:1536–1545

- Sutter JU, Sieben C, Hartel A, Eisenach C, Thiel G, Blatt MR (2007) Abscisic acid triggers the endocytosis of the *Arabidopsis* KAT1 K<sup>+</sup> channel and its recycling to the plasma membrane. *Curr Biol* 17:1396–1402
- Szyroki A, Ivashikina N, Dietrich P, Roelfsema MR, Ache P, Reintanz B, Deeken R, Godde M, Felle H, Steinmeyer R, Palme K, Hedrich R (2001) KAT1 is not essential for stomatal opening. *Proc Natl Acad Sci USA* 98:2917–2921
- Talbott LD, Zeiger E (1996) Central roles for potassium and sucrose in guard-cell osmo-regulation. *Plant Physiol* 111:1051–1057
- Talbott LD, Zeiger E (1998) The role of sucrose in guard cell osmo-regulation. *J Exp Bot* 49:329–337
- Tanaka Y, Kutsuna N, Kanazawa Y, Kondo N, Hasezawa S, Sano T (2007) Intra-vacuolar reserves of membranes during stomatal closure: the possible role of guard cell vacuoles estimated by 3-D reconstruction. *Plant Cell Physiol* 48:1159–1169
- Tang RH, Han S, Zheng H, Cook CW, Choi CS, Woerner TE, Jackson RB, Pei ZM (2007) Coupling diurnal cytosolic Ca<sup>2+</sup> oscillations to the CAS-IP3 pathway in *Arabidopsis*. *Science* 315:1423–1426
- Trejo CL, Clephan AL, Davies W (1995) How do stomata read abscisic acid signals? *Plant Physiol* 109:803–811
- Trejo CL, Davies WJ, Ruiz L (1993) Sensitivity of stomata to abscisic acid (an effect of the mesophyll). *Plant Physiol* 102:497–502
- Umezawa T, Okamoto M, Kushihiro T, Nambara E, Oono Y, Seki M, Kobayashi M, Koshihara T, Kamiya Y, Shinozaki K (2006) CYP707A3, a major ABA 8'-hydroxylase involved in dehydration and rehydration response in *Arabidopsis thaliana*. *Plant J* 46:171–182
- Vahisalu T, Kollist H, Wang YF, Nishimura N, Chan WY, Valerio G, Lamminmaki A, Brosche M, Moldau H, Desikan R, Schroeder JI, Kangasjarvi J (2008) SLAC1 is required for plant guard cell S-type anion channel function in stomatal signaling. *Nature* 452:487–491
- Vavasseur A, Raghavendra AS (2005) Guard cell metabolism and CO<sub>2</sub> sensing. *New Phytol* 165:665–682
- Very AA, Sentenac H (2003) Molecular mechanisms and regulation of K<sup>+</sup> transport in higher plants. *Annu Rev Plant Biol* 54:575–603
- Wang XQ, Ullah H, Jones AM, Assmann SM (2001) G protein regulation of ion channels and abscisic acid signaling in *Arabidopsis* guard cells. *Science* 292:2070–2072
- Wang Y, Ying J, Kuzma M, Chalifoux M, Sample A, McArthur C, Uchacz T, Sarvas C, Wan J, Dennis DT, McCourt P, Huang Y (2005) Molecular tailoring of farnesylation for plant drought tolerance and yield protection. *Plant J* 43:413–424
- Ward JM, Schroeder JI (1994) Calcium-activated K<sup>+</sup> channels and calcium-induced calcium release by slow vacuolar ion channels in guard cell vacuoles implicated in the control of stomatal closure. *Plant Cell* 6:669–683
- Webb AAR, McAinsh MR, Mansfield TA, Hetherington AM (1996) Carbon dioxide induces increases in guard cell cytosolic free calcium. *Plant J* 9:297–304
- Weinl S, Held K, Schlucking K, Steinhorst L, Kuhlert S, Hippler M, Kudla J (2008) A plastid protein crucial for Ca<sup>2+</sup>-regulated stomatal responses. *New Phytol* 179:675–686
- Wilkinson S, Clephan, A.L. and Davies, W.J. (2001) Rapid low temperature-induced stomatal closure occurs in cold-tolerant *Commelina communis* leaves but not in cold-sensitive tobacco leaves, via a mechanism that involves apoplastic calcium but not abscisic acid. *Plant Physiol* 126:1566–1578
- Wilkinson, S., Corlett, J.E., Oger, L. and Davies, W.J. (1998) Effects of xylem pH on transpiration from wild-type and flacca tomato leaves. A vital role for abscisic acid in preventing excessive water loss even from well-watered plants. *Plant Physiol* 117:703–709
- Wilkinson S., Davies W.J. (1997) Xylem Sap pH Increase: A Drought Signal Received at the Apoplastic Face of the Guard Cell That Involves the Suppression of Saturable Abscisic Acid Uptake by the Epidermal Symplast. *Plant Physiol* 113:559–573
- Wille AC, Lucas WJ (1984) Ultrastructural and histochemical studies on guard cells. *Planta* 160:129–142
- Xie X, Wang Y, Williamson L, Holroyd GH, Tagliavia C, Murchie E, Theobald J, Knight MR, Davies WJ, Leyser HM, Hetherington AM (2006) The identification of genes involved in the stomatal response to reduced atmospheric relative humidity. *Curr Biol* 16:882–887
- Yang Y, Costa A, Leonhardt N, Siegel RS, Schroeder JI (2008) Isolation of a strong *Arabidopsis* guard cell promoter and its potential as a research tool. *Plant Methods* 4:6
- Yoshida R, Hobo T, Ichimura K, Mizoguchi T, Takahashi F, Aronso J, Ecker JR, Shinozaki K (2002) ABA-activated SnRK2 protein kinase is required for dehydration stress signaling in *Arabidopsis*. *Plant Cell Physiol* 43:1473–1483
- Yoshida R, Umezawa T, Mizoguchi T, Takahashi S, Takahashi F, Shinozaki K (2006) The regulatory domain of SRK2E/OST1/SnRK2.6 interacts with ABI1 and integrates abscisic acid (ABA) and osmotic stress signals controlling stomatal closure in *Arabidopsis*. *J Biol Chem* 281:5310–5318
- Young JJ, Mehta S, Israelsson M, Godoski J, Grill E, Schroeder JI (2006) CO<sub>2</sub> signaling in guard cells: calcium sensitivity response modulation, a Ca<sup>2+</sup>-independent phase and CO<sub>2</sub> insensitivity of the *gca2* mutant. *Proc Natl Acad Sci USA* 103:7506–7511
- Yu R, Huang RF, Wang XC, Yuan M (2001) Microtubule dynamics are involved in stomatal movement of *Vicia faba* L. *Protoplasma* 216:113–118
- Zhang J, Davies WJ (1990) Changes in the concentration of ABA in xylem sap as a function of changing soil water status can account for changes in leaf conductance and growth. *Plant Cell Environ* 13:277–285
- Zhang W, Qin C, Zhao J, Wang X (2004) Phospholipase Dα1-derived phosphatidic acid interacts with ABI1 phosphatase

- 2C and regulates abscisic acid signaling. Proc Natl Acad Sci USA 101:9508–9513
- Zhang X, Zhang L, Dong F, Gao J, Galbraith DW, Song CP (2001) Hydrogen peroxide is involved in abscisic acid-induced stomatal closure in *Vicia faba*. Plant Physiol 126:1438–1448
- Zhu J, Gong Z, Zhang C, Song CP, Damsz B, Inan G, Koiwa H, Zhu JK, Hasegawa PM, Bressan RA (2002) OSM1/SYP61: a syntaxin protein in *Arabidopsis* controls abscisic acid-mediated and non-abscisic acid-mediated responses to abiotic stress. Plant Cell 14:3009–3028



# Chapter 15

## Responses to Macronutrient Deprivation

Arthur R. Grossman\*, David Gonzalez-Ballester, Nakako Shibagaki,  
Wirulda Pootakham, and Jeffrey Moseley  
*Department of Plant Biology, The Carnegie Institution, 260 Panama Street,  
Stanford, CA 94305, USA*

W. Pootakham  
*Department of Biological Sciences, Stanford University,  
Stanford, CA 94305, USA*

Summary .....	308
I Introduction.....	309
II Nitrogen Uptake and Assimilation .....	309
A Nitrogen in the Environment.....	309
B Transport of Nitrogen-Containing Compounds .....	310
C Regulation of Transport .....	313
D <i>Chlamydomonas</i> Nitrate and Nitrite Reductase .....	314
E Glutamine Synthetase .....	315
III Responses to Sustained Nitrogen Starvation.....	316
IV Sulfur Uptake and Assimilation.....	316
A Sulfur in the Environment .....	316
B Sulfate Acquisition and Transport .....	317
1 Hydrolysis .....	317
2 Transport Across the Plasma Membrane.....	318
3 Transport into the Chloroplast.....	319
C Reductive Assimilation .....	320
V Control of Sulfur Starvation Responses .....	322
A Specific and General Responses .....	322
B Genes Responsive to Sulfur Deprivation.....	322
C Genes Controlling Sulfur Deprivation Responses .....	323
D Sequence of Regulatory Events.....	325
VI Phosphate Uptake and Assimilation.....	327
A Phosphate in the Environment .....	327
B Phosphatases.....	328
C Phosphate Transport .....	328
D Polyphosphate Synthesis and Mobilization .....	329
E Nucleic Acids .....	329
F Phospholipids .....	330
G Phosphorus Deficiency and Photosynthesis.....	330

\* Author for Correspondence, e-mail: arthurg@stanford.edu

VII	Control of Phosphorus Starvation Responses .....	330
A	Mutant Isolation .....	330
1	PSR1 (Regulator in <i>Chlamydomonas reinhardtii</i> Associated with Phosphate Stress Response) ...	331
2	Low Phosphorus Bleaching Strains .....	332
B	PSR1-Dependent Gene Expression .....	332
1	Phosphatases .....	332
2	Transporters .....	333
3	Other Genes .....	333
4	“Electron Valves” .....	333
C	Sequence of Regulatory Events .....	334
VIII	Conclusions .....	334
	Acknowledgements .....	335
	References .....	335

## Summary

Photosynthetic organisms have developed elaborate mechanisms to acquire macronutrients and to adjust to conditions in which those nutrients become limiting to growth. Some of the responses of photosynthetic organisms to macronutrient limitation may be specific for a particular nutrient and involve the development of various mechanisms to scavenge the limiting nutrient from the external milieu, which may require elevated synthesis of high affinity transport systems, the redistribution of internal nutrient stores and the synthesis of hydrolytic enzymes that release the nutrient from organic substrates in the soil. Other responses may be of a more general nature, occurring during a number of different nutrient limitation conditions, and involve modifying the biosynthetic machinery of the cell, including the photosynthetic apparatus. In this review we focus on the acquisition of the macronutrients nitrogen, sulfur and phosphorus from the environment, and the ways in which the unicellular green alga *Chlamydomonas reinhardtii* acclimates to changes in its nutrient environment.

**Keywords:** ammonium • assimilation • macronutrients • nitrate nutrient deprivation • phosphate • phosphorus • sulfur • transport

*Abbreviations:* AAP – *Arabiopsis* amino acid permease; ABC transporter ATP binding cassette transporter; AMP – adenosine monophosphate; AMT – ammonium transporter; AphVIII – gene encoding a protein that confers resistance to paromomycin; APK – adenosine 5'-phosphosulfate kinase; APR – adenosine 5'-phosphosulfate reductase; APS – adenosine 5'-phosphosulfate; ARG7 – gene encoding an enzyme in the pathway for arginine biosynthesis (argininosuccinate lyase); ARS – arylsulfatase; ars11 – mutant in a serine threonine kinase associated with control of the responses of *Chlamydomonas reinhardtii* to sulfur deprivation; ASL – gene encoding O-acetylserine (thiol) lyase; ASQD – 2'-O-acyl-sulfoquinovosodiacylglycerol; ATS – gene encoding ATP sulfurylase; CpDNA – chloroplast DNA; CpRNA – chloroplast RNA; CysT – membrane component of ABC transporter for sulfate; DMS – dimethylsulfide; DMSP – dimethyl sulfonio-propionate; DRA – chloride/bicarbonate antiporter; ECP – extracellular polypeptide; EST – expressed sequence tag; FAR – regulatory locus involved in the utilization of nitrogen in *Chlamydomonas reinhardtii*;

Fd – ferredoxin; FNR – Fd-NADP-oxidoreductase; GOGAT – glutamine-2-oxoglutarate amino-transferase; GS – glutamine synthetase; GSH – glutathione; HANiT – high affinity nitrite transporter; HANT – high affinity nitrate transporter; hf-2 – high fluorescence mutant deficient for sulfolipids; HYDA – hydrogenase proteins; IMP – inosine monophosphate; IRL protein – isoflavone reductase-like protein in maize that has few sulfur amino acids; LANT – low affinity nitrate transporter; LHC – light harvesting complex; LHCSR2 – light harvesting complex protein, stress related; LHT – lysine histidine transporter; LOV domain – domain that can be involved in sensing light, oxygen and voltage; LPB1 – low phosphate bleaching phenotype; MYB domain – derived from myeloblastosis and often in regulatory proteins; NAR – nitrite–nitrate transporter genes; NIA1 – nitrate reductase gene; NII1 – nitrite reductase gene; NIT – nitrate assimilation/regulation loci in *Chlamydomonas reinhardtii*; NiR – nitrite reductase; NR – nitrate reductase; NRG – regulatory locus involved in the utilization of nitrogen in *Chlamydomonas reinhardtii*; NRT – nitrate transporter genes;

## I Introduction

Nutrients have several structural, functional and regulatory roles in organisms. While some nutrients are required at high levels, and are generally considered macronutrients, others are needed in much lower amounts and are considered micronutrients. The macronutrients for which both acquisition and assimilation have been examined in some detail are nitrogen (N), phosphorus (P) and sulfur (S). These nutrients may be limiting in the environment, especially N and P, and organisms have not only evolved a number of different strategies for increasing the efficiency of nutrient acquisition and assimilation, but have also developed mechanisms to re-distribute these nutrients in the cell. Global cycles depicting the flow of N, P and S within the environment are given in Figs. 1, 2, and 3. This chapter discusses utilization of these nutrients in photosynthetic organisms and the various strategies adopted by these organisms to cope with changing exogenous nutrient conditions, with an emphasis on studies

that have been performed with the unicellular model alga *Chlamydomonas reinhardtii*.

## II Nitrogen Uptake and Assimilation

All organisms require high levels of N, especially for the synthesis of proteins, nucleic acids and various N-containing metabolites. While some prokaryotic organisms can fix dinitrogen (present in the atmosphere), most organisms take up either nitrate/nitrite (compounds that need to be reduced in the cell) or ammonia/urea (organic sources of N)

### A Nitrogen in the Environment

Frequently, the growth of an organism in the natural environment is limited by N availability. In the oligotrophic oceans, the levels of both N and iron (Fe) are extremely low. Low N availability is also an issue in agricultural settings, and fields are often supplemented with fertilizers containing

---

OAS – O-acetylserine; OASTL – O-acetylserine (thiol) lyase; OPH – O-phosphohomoserine; PAPS – 3'-phosphoadenosine 5'-phosphosulfate; PAS domain – protein domain involved in sensing and protein-protein interaction named from Per (period circadian protein), Arnt (Ah receptor nuclear translocator protein) and Sim (single-minded protein); PC – phosphatidylcholine; PE – phosphatidylethanolamine; PG – phosphatidylglycerol; PHO2 – phosphate regulatory E2 ubiquitin conjugase; PHOX – protein associated with extracellular phosphatase activity in *Chlamydomonas reinhardtii* and *Volvox carteri*; PHR1 – involved in phosphorus deprivation responses in *Arabidopsis thaliana*; Pi – inorganic phosphate; P<sub>i</sub> – phosphatidylinositol; PNP – polynucleotide Phosphate; PNPase/polynucleotide phosphorylase; PQ – plastoquinone pool; PTA – phosphate transporter, type A class; PTB – phosphate transporter, type B class; QA and QB primary and secondary acceptors of photosystem II, respectively; RH – rhesus protein; ROS – reactive oxygen species; PSR1 – regulator in *Chlamydomonas reinhardtii* associated with phosphate stress response; RuBP – ribulose-1,5-bisphosphate; SABC – nucleotide binding protein of ABC type transporter; SAC1 – transporter-like proteins associated with control of the responses of *Chlamydomonas reinhardtii* to sulfur deprivation; sac1 – mutant in the gene encoding SAC1; SAC3/SNRK2.2 – serine threonine kinase associated with control of the responses of *Chlamydomonas*

*reinhardtii* to sulfur deprivation; sac3 – mutant in the gene encoding SAC3; SAM – S-adenosylmethionine; SAT – serine acetyltransferase; SBDP – selenium binding protein; SBP – substrate binding protein of ABC type transporter; *SERAT* – gene encoding serine acetyltransferase; SGTE3 – ubiquitin ligase similar to Skp1-Cullin-F-box protein (SCF) ubiquitin ligases; SIR – sulfite reductase; SIZ1 – sap interacting zinc finger protein which is plant SUMO E3 ligase; SLC26 – family of anion transporters that include the sulfate transporters; SLT – sulfate transporter (animal type); SNRK – SNF-related kinase; SpoIIAA – antisigma factor antagonist in *Bacillus subtilis* with similarity to STAS domain; SQD1 – UDP-sulfoquinovose synthase; *sqd1* – mutant in the gene encoding SQD1; SQDG – sulfoquinovosodiacylglycerol; STAS – domain found attached to certain anion transporters such as the sulfate transporter that has homology to an antisigma factor antagonist in *Bacillus subtilis*; sulfate transporter and sigma factor domain; Sul – sulfate transporter in yeast; SULP – component of chloroplast sulfate transporter in *Chlamydomonas reinhardtii*; SULTR – sulfate transporters (plant type); SUMO – small ubiquitin-like modifier; TMD – trans-membrane domain; Trk – domain of unknown function found associated with some transporters; UDP – uridine diphosphate; VTC – vacuolar transport chaperone; X-SO<sub>4</sub><sup>2-</sup> – 5-bromo-4-chloro-3-indolyl sulfate

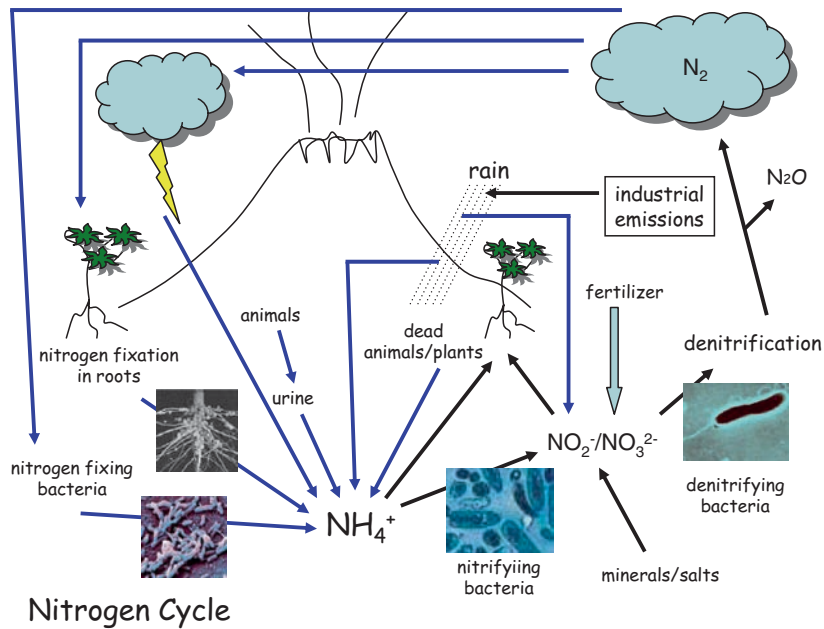

Fig. 1. Nitrogen cycle. Generally,  $NO_3^{2-}$  is the major form of nitrogen in the environment; although  $NH_4^+$  and  $NO_2^-$  can be present at significant levels as well (high  $NH_4^+$  levels are often toxic to organisms). As indicated,  $NH_4^+$  can be generated from  $N_2$  through the action of animal metabolism, lightning, volcanic activity and  $N_2$  fixation. The fixation of  $N_2$  can be performed by either free-living bacteria or bacteria associated with the nodules of leguminous plants.  $NH_4^+$  can be oxidized through the action of nitrifying bacteria, which use ammonia monooxygenase to oxidize ammonia to hydroxylamine ( $NH_2OH$ ) and then nitrite oxidoreductase to oxidize  $NO_2^-$  to  $NO_3^{2-}$ . Oxides of nitrogen can be converted to  $N_2$  by denitrification, an anaerobic process performed by specific bacteria (Modified from <http://telstar.ote.cmu.edu/enviro/m3/s4/graphics/embedded/nitronodules.gif>; [http://www.markergene.com/WebNewsletter7.4\\_files/image007.gif](http://www.markergene.com/WebNewsletter7.4_files/image007.gif); <http://www.anoxkaldnes.com/Bilder/jpg/RD7.jpg>; [http://staffwww.fullcoll.edu/tmorris/elements\\_of\\_ecology/images/bacteria\\_denitrifying.jpg](http://staffwww.fullcoll.edu/tmorris/elements_of_ecology/images/bacteria_denitrifying.jpg)) [See Color Plate 8, Fig. 14].

high N concentrations. The N applied to agricultural lands often leaches from soils, contaminating neighboring aquatic ecosystems, which can cause eutrophication and the destruction of much of the animal life in that ecosystem. Some plants develop partnerships with microbes to satisfy their need for N. Leguminous plants participate in symbiotic associations with the diazotrophic or nitrogen-fixing, soil bacterium *Rhizobium*. The bacteria enter the plant host through root hairs, penetrate deep into the cortical tissue, where they proliferate and form specialized structures called nodules (Jones et al. 2007). The nodules are anaerobic factories for the fixation of molecular nitrogen ( $N_2$ ). Nodule development involves a series of physical, metabolic and regulatory interactions between the bacterium and the plant. N-limitation in plants that do not form nodules will often elicit changes in the root architecture; the root to shoot ratio increases and lateral root branches shorten

relative to nutrient-sufficient plants. Elevated levels of  $NO_3^{2-}$  inhibit root growth relative to shoot growth (Scheible et al. 1997; Zhang et al. 1999). Indeed, the internal level of nitrogenous metabolites and/or the N:C ratio may serve as a systemic signal that alters root development (Scheible et al. 1997).

### B Transport of Nitrogen-Containing Compounds

Numerous transport systems have been characterized that are specific for different N compounds. The biosynthesis of these transporters and their accumulation in membranes is often controlled by levels of both intracellular and extracellular N-containing compounds. Microorganisms, algae and plants can actively transport and utilize  $NH_4^+$ ,  $NO_3^{2-}$ ,  $NO_2^-$ , urea and some amino acids. The most abundant source of N in the environment is



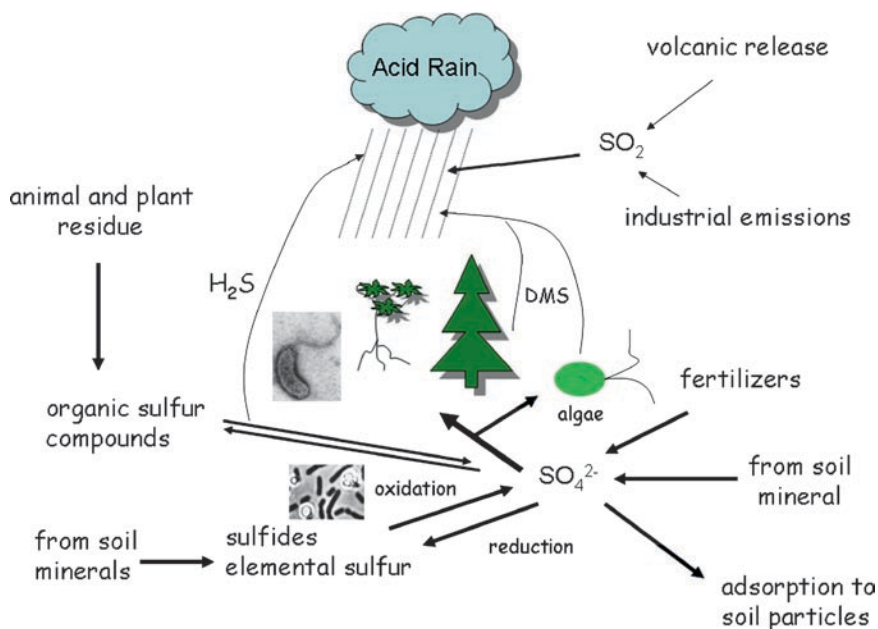

Fig. 2. Sulfur cycle. The most abundant form of sulfur in the environment is  $\text{SO}_4^{2-}$ , although certain environments can have high levels of sulfides ( $\text{H}_2\text{S}$ ) and elemental sulfur ( $\text{S}^0$ ).  $\text{SO}_4^{2-}$  can be reduced by plants and bacteria in a reductive assimilatory process (to make cysteine methionine and glutathione). The formation of  $\text{H}_2\text{S}$  often occurs as a result of bacterial break down of organic matter in the absence of oxygen (major process in swamps and sewers). DMSP or dimethylsulfoniopropionate  $[(\text{CH}_3)_2\text{S}^+\text{CH}_2\text{CH}_2\text{COO}^-]$ , is produced by marine phytoplankton, seaweeds and some terrestrial and aquatic vascular plants. There are two major volatile breakdown products of DMSP, methanethiol ( $\text{CH}_3\text{SH}$ ), which can be assimilated by bacteria into protein and DMS or dimethyl sulfide ( $\text{CH}_3\text{SCH}_3$ ), which is released into the atmosphere and plays a key role in cloud formation; methanethiol can also be converted to DMS. Furthermore, a number of bacteria and archaea can oxidize inorganic sulfur compounds such as  $\text{H}_2\text{S}$  (toxic to most organisms) and  $\text{S}^0$  and use the electrons for growth (Modified from <http://www.bio.ku.dk/nuf/images/C.limicola.LM.jpg>; <http://www.princeton.edu/~chm333/2004/Bioremediation/images/Desulfovibrio>) [See Color Plate 9, Fig. 15].

typically  $\text{NO}_3^{2-}$  (Marschner 1995), and multiple transporters in plants and algae are devoted to capturing both  $\text{NO}_3^{2-}$  and  $\text{NO}_2^-$ . On the other hand,  $\text{NH}_4^+$  is metabolically less expensive relative to  $\text{NO}_3^{2-}$  since it does not have to be reduced prior to incorporation into amino acids and nitrogenous bases. Many microbes can use  $\text{NH}_4^+$  as a sole N source, although it is not a sufficient N source for most plants and the administration of  $\text{NH}_4^+$  to plants as a sole N source can cause stunted plant growth.  $\text{NO}_3^{2-}$  appears to prevent stunting by affecting the cellular concentration of plant hormones, including cytokinins and abscisic acid (Peuke et al. 1998; Walch-Liu et al. 2000), suggesting that  $\text{NO}_3^{2-}$  is not only a dominant source of N, but that it may also function in regulating hormone production.

Based on analyses of the draft genome sequence (Merchant et al. 2007), there are ten putative  $\text{NH}_4^+$  transporters (encoded by eight ammonium transporter genes designated *AMT* and two *RH*-like genes) in *Chlamydomonas*. *AMT* genes were previously identified in *Chlamydomonas* (Gonzalez-Ballester et al. 2004), and of the organisms with characterized full genomes, only rice has more. The functions of some of these transporters have been examined at the biochemical and genetic levels (Fernández and Galvan 2007). Mutants defective for  $\text{NH}_4^+$  transport were selected based on their resistance to methyl-ammonium, and the lesions in the mutant strains were mapped to two nuclear loci. One locus identified a gene encoding a constitutively expressed, low-affinity *AMT*-type transporter with high maximum uptake velocity,

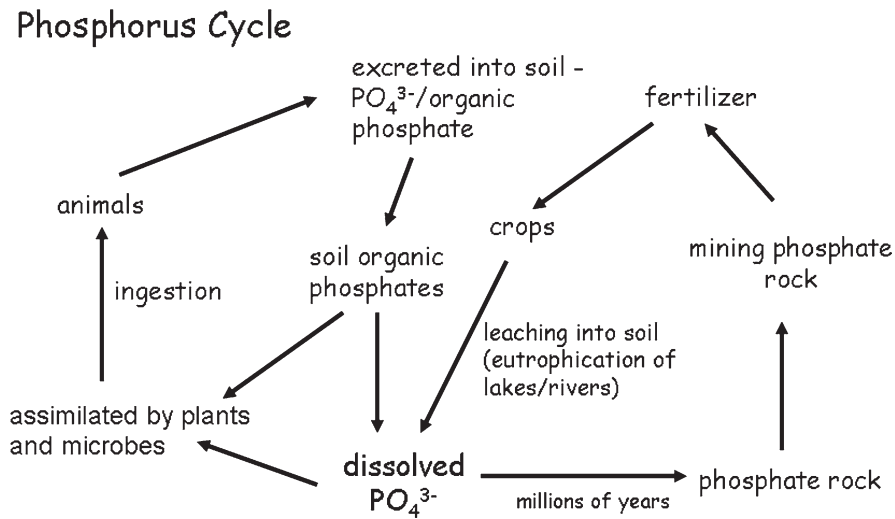

Fig. 3. Phosphorus cycle. A major source of bioavailable phosphorus is  $\text{H}_2\text{PO}_4^-$ , which comes from the weathering of terrestrial,  $\text{PO}_4^{3-}$ -containing minerals, primarily apatite  $[\text{Ca}_5(\text{PO}_4)_3\text{OH}]$ . Other sources include  $\text{PO}_4^{3-}$  in the form of insoluble aluminum and iron oxides, that is adsorbed to soil particles and that is covalently bound to organic molecules. Plants, microbes and fungi secrete organic acids and enzymes to mobilize environmental  $\text{PO}_4^{3-}$ . Once  $\text{PO}_4^{3-}$  becomes bioavailable, it is rapidly taken up by plants, microbes and algae, which are in turn consumed by grazers. Phosphorus is returned to the environment as organic phosphates upon excretion, death and decay of organisms.  $\text{PO}_4^{3-}$ -rich rocks are formed over millennia by sedimentation of calcium  $\text{PO}_4^{3-}$  salts that may originate from the skeletons and shells of oceanic organisms. Tectonically uplifted phosphorite deposits are mined for use as fertilizer. The excessive use of fertilizer can lead to the leaching of  $\text{PO}_4^{3-}$  from agricultural environments, causing the eutrophication of rivers and lakes.

while the other identified an  $\text{NH}_4^+$ -repressible, high-affinity *AMT* with low maximum uptake velocity. These results suggest that low-affinity systems function under N-replete conditions, while high-affinity systems become active when the concentration of  $\text{NH}_4^+$  in the environment becomes limiting (Franco et al. 1988). In general, the large number of *Chlamydomonas* *AMTs*, as well as the generally high membership in other families of macronutrient transporters (Moseley et al. 2006; Gonzalez-Ballester and Grossman 2008) may reflect severe competition for limiting resources in the soil environments in which *Chlamydomonas* grows. A detailed genetic and biochemical analysis of all putative *AMTs* is required to confirm their function. Indeed, two of the putative  $\text{NH}_4^+$  transporters of *Chlamydomonas*, that group with animal-type transporters and resemble the mammalian RH proteins (blood group Rhesus polypeptides), may function in transporting inorganic carbon rather than  $\text{NH}_4^+$  (Soupeine et al. 2004; Kustu and Inwood 2006).

The dominant N-containing compound available for transport in most soil environments is  $\text{NO}_3^{2-}$ . Plants not only maintain near constant cytoplasmic  $\text{NO}_3^{2-}$  levels (Miller and Smith 1996), but also store it in the vacuole where it can be recruited when environmental N becomes scarce (van der Leij et al. 1998). An energy-dependent transport process moves  $\text{NO}_3^{2-}$  from the extracellular space in plant roots into epidermal and cortical cells. The  $\text{NO}_3^{2-}$  is then transported through endodermal cells, loaded into xylem vessels and trafficked to the leaves, where it is reduced to  $\text{NO}_2^-$  in the cytoplasm and is then further reduced to  $\text{NH}_4^+$  in the chloroplast. The  $\text{NH}_4^+$  is predominantly incorporated into glutamine by the enzyme glutamine synthetase, and the ferredoxin-dependent glutamate synthetase or glutamine-2-oxoglutarate aminotransferase (GOGAT) catalyze transamination of an amino group from glutamine to 2-oxoglutarate to form two molecules of glutamate. Glutamate is used for the synthesis of aspartate and alanine,

and both glutamate and aspartate can serve as amino donors for the biosynthesis of other amino acids and various N-containing compounds.

There are over ten genes encoding polypeptides involved in the uptake and assimilation of  $\text{NO}_3^{2-}/\text{NO}_2^-$ , many of which are clustered on the *Chlamydomonas* genome (Quesada et al. 1993, 1998; Fernández and Galvan 2007). One locus contains the genes encoding transport systems I and II (*NRT2;1*, *NRT2;2*, *NAR2* genes), the nitrate (*NIA1*) and nitrite (*NIII*) reductases and a chloroplast nitrite transporter (*NARI.1*) (Fernández and Galvan 2007). Transport system I, encoded by *NRT2;1/NAR2*, catalyzes high affinity transport of both  $\text{NO}_3^{2-}$  (high affinity nitrate transport or HANT) and  $\text{NO}_2^-$  (high affinity nitrite transport or HANiT) while system II, encoded by *NRT2;2/NAR2*, exhibits monospecific HANT activity. Both systems require the *NAR2* gene product, a polypeptide that may associate with *NRT2;1* and *NRT2;2* as a critical structural element of the transporters (Quesada and Fernández 1994; Quesada et al. 1994; Galván et al. 1996). This hypothesis is supported by the finding that electrogenic  $\text{NO}_3^{2-}$  transport into *Xenopus* oocytes occurs only when the oocytes harbor both the *NRT2;1* and *NAR2* polypeptides (Zhou et al. 2000). A second locus contains system III; this system is encoded by *NRT2;3* and is independent of *NAR2*. System III has both HANiT and low-Affinity  $\text{NO}_3^{2-}$  transporter (LANT) activities (Rexach et al. 1999). All of the genes contained in the loci described above accumulate to high levels when cells are maintained in  $\text{NO}_3^{2-}$ , while much lower levels are observed in cells maintained on  $\text{NH}_4^+$ . Another transport activity has been designated system IV, which encodes both HANT and HANiT activities and is probably encoded by *NRT2;4* (Rexach et al. 1999). In addition to *NARI.1*, five more *NARI* genes have been identified (Mariscal et al. 2006). Most of these genes are regulated by the nitrogen/carbon status of the cells, and *NARI.2* has been suggested to be the chloroplast  $\text{NO}_2^-/\text{HCO}_3^-$  transporter (Rexach et al. 2000).

In addition to  $\text{NH}_4^+$ ,  $\text{NO}_3^{2-}$ , and  $\text{NO}_2^-$ , *Chlamydomonas* utilizes N from urea as well as from certain nitrogenous bases. Purines (Pineda and Cardenas 1996) and urea (Kirk and Kirk 1978) can both support the growth of *Chlamydomonas* in the absence of other N sources. Plant roots have active uptake systems for most amino

acids, which would supply them with significant N when the plants are growing in soils rich in organic matter. Genes encoding these transporters in *Arabidopsis* have been cloned (Fischer et al. 1998) and many are tissue specific, suggesting a role in moving amino acids between plant tissue types and having broad substrate specificities (Fischer et al. 1995, 1998). AAP3 (*Arabidopsis* amino acid permease) is specific to *Arabidopsis* roots (Fischer et al. 1995) and probably facilitates amino acid transport into the phloem (Okumoto et al. 2004), while LHT1 (lysine histidine transporter) may function in taking up amino acids by roots and in supplying leaf mesophyll cells with amino acids from the xylem (Hirner et al. 2006). Other plant transporters move small oligopeptides across membranes (Rentsch et al. 1998; Koh et al. 2002; Stacey et al. 2002), but their specific role in N metabolism may not be clear. In contrast, *Chlamydomonas* does not readily take up most amino acids, with the exception of arginine (Kirk and Kirk 1978). However, when N limited, this alga synthesizes an extracellular L-amino acid oxidase (Piedras et al. 1992; Vallon et al. 1993) that catalyzes the release of  $\text{NH}_4^+$  via deamination of amino acids in its immediate environment.

### C Regulation of Transport

In *Arabidopsis* there are over 50 putative  $\text{NO}_3^{2-}$  transporters of 2 types, NRT1 and NRT2. Most of the NRT1 proteins are low affinity transporters while all NRT2 proteins are high affinity transporters (Miller et al. 2007; Tsay et al. 2007). Some members of the NRT1 family are dipeptide transporters that are active with a broad spectrum of di/tripeptides. Furthermore, most NRT proteins are expressed in a tissue specific manner and are controlled by various metabolites (Miller et al. 2007; Tsay et al. 2007). Both N and C metabolites regulate the assimilation of  $\text{NO}_3^{2-}$ . For example,  $\text{NH}_4^+$  and/or  $\text{NH}_4^+$  metabolites strongly suppress  $\text{NO}_3^{2-}$  assimilation in plants (Stitt 1999; Stitt and Krapp 1999; Forde 2000). This conclusion is supported by the finding that tobacco plants with elevated expression of nitrate reductase (NR) accumulate increased concentrations of glutamine and exhibit depressed rates of  $\text{NO}_3^{2-}$  uptake relative to plants with normal levels of NR expression (Gojon et al. 1998). Furthermore, accumulation of *AtNRT1;1* and *AtNRT2;1* mRNAs is stimulated by  $\text{NO}_3^{2-}$

(Filleur and Daniel-Vedele 1999; Lejay et al. 1999), and an *Arabidopsis* mutant lacking NR accumulates high levels of both  $\text{NO}_3^{2-}$  and *AtNRT1;1* and *AtNRT2;1* transcripts. These findings reflect the inability of the mutant plant to generate high intracellular levels of reduced N metabolites to feedback suppress expression of the *NRT* genes. In accord with this hypothesis, elevated  $\text{NH}_4^+$  and glutamine levels cause reduced expression of *AtNRT2;1* (Zhou et al. 1999) and its homologs in various plants (Quesada et al. 1997; Amarasinghe et al. 1998). The root *AtNRT2;1* mRNA accumulates under low N conditions, correlating with the appearance of high-affinity  $\text{NO}_3^{2-}$  uptake; again, elevated mRNA levels may be a consequence of lower levels of reduced N metabolites which releases *AtNRT2.1* from feedback inhibition. Furthermore, expression of *AtNRT1.1* and *AtNRT2.1* are under diurnal control, with peak mRNA abundance just prior to the dark period and lowered abundance as the plants enter the dark period (Lejay et al. 1999). Exogenous sucrose prevents the decline in mRNA during the dark period (Lejay et al. 1999), suggesting that C metabolite levels influence  $\text{NO}_3^{2-}$  uptake and that the circadian pattern of *NRT* gene expression may result from changes in intracellular C and N metabolite levels (e.g., ratio of N to C metabolites).

Interestingly, *NRT1.1* appears to be a dual affinity transporter; the affinity state depends upon the phosphorylation state of the protein (Liu and Tsay 2003). The protein switches from low to high affinity transport by phosphorylation of threonine 101. This transporter may also be a critical component of the  $\text{NO}_3^{2-}$  sensing mechanism of the plant (Remans et al. 2006).

#### D *Chlamydomonas Nitrate and Nitrite Reductase*

Most reducing equivalents used for the conversion of  $\text{NO}_3^{2-}$  to  $\text{NH}_4^+$  are generated by photosynthetic electron transport. While the reduction of  $\text{NO}_3^{2-}$  via NR occurs in the cytoplasm of plant and algal cells,  $\text{NO}_2^-$  is reduced in the chloroplast and the electron donor for the  $\text{NO}_2^-$  reductase (NiR) reaction is reduced ferredoxin (Fd). In non-photosynthetic tissue, NADPH, generated via the oxidative pentose phosphate pathway (Jin et al. 1998; Redinbaugh and Campbell 1998), allows the reduc-

tion of Fd and the conversion of  $\text{NO}_3^{2-}$  to  $\text{NH}_4^+$ .  $\text{NO}_3^{2-}$  induces the expression of genes encoding Fd (Matsumura et al. 1997), Fd-NADP-oxidoreductase or ferredoxin:NADP(+) oxidoreductase (FNR) (Aoki and Ida 1994; Ritchie et al. 1994) and 6-phosphogluconate dehydrogenase; the latter is an integral component of the oxidative pentose phosphate pathway (Redinbaugh and Campbell 1998). The cluster of genes encoding the  $\text{NO}_3^{2-}/\text{NO}_2^-$  assimilation proteins of *Chlamydomonas* also contains the structural genes encoding NR (*NIA1*) (Fernández et al. 1989), which has a functional molybdopterin cofactor (Fernández et al. 1998), and NiR (*NIII*) with a siroheme and  $[\text{Fe}_4\text{S}_4]$  cluster that functions as a redox center (Campbell and Kinghorn 1990).

Like the control of genes encoding the  $\text{NO}_3^{2-}/\text{NO}_2^-$  transporters, N metabolites are key regulators of NR and NiR. The regulation of N assimilation genes in *Chlamydomonas* is depicted in Fig. 4. The addition of  $\text{NH}_4^+$  to  $\text{NO}_3^{2-}$ -grown *Chlamydomonas* cells triggers a rapid decrease in NR activity, reflecting both enzyme inactivation, which leads to more rapid degradation (Franco et al. 1987), and inhibition of de novo synthesis (Guerrero et al. 1981; Fernández and Cardenas 1989). Analyses of a *Chlamydomonas* strain expressing *NIA1* from the *cabII-1* gene promoter also suggest the occurrence of posttranscriptional mechanisms of control (Navarro et al. 1996). Furthermore, constitutive *NIA1* expression in *Chlamydomonas* caused altered regulation of the  $\text{NO}_3^{2-}/\text{NO}_2^-$  transporters, supporting the idea that N metabolites downstream of NR are important for modulating  $\text{NO}_3^{2-}$  and  $\text{NO}_2^-$  acquisition (Navarro et al. 1996). Light also plays a central role in controlling  $\text{NO}_3^{2-}$  assimilation and the uptake of a number of anions (Quiñones and Aparicio 1990; Aparicio and Quinones 1991). NR activation occurs in blue light (Kamiya 1988; Aparicio and Quinones 1991), with blue light also being required for the biosynthesis of NiR in the green alga *Monorhaphidium braunii* (Quiñones and Aparicio 1990). There is also a blue light requirement for the biosynthesis of NR and a  $\text{NO}_2^-$  transport system following the transfer of *Chlamydomonas* cells from medium in which the sole N source was  $\text{NH}_4^+$  to  $\text{NO}_2^-$ -containing medium devoid of  $\text{NH}_4^+$  (Quiñones et al. 1999).

Several *Chlamydomonas* mutants lacking NR activity have been isolated and placed into three



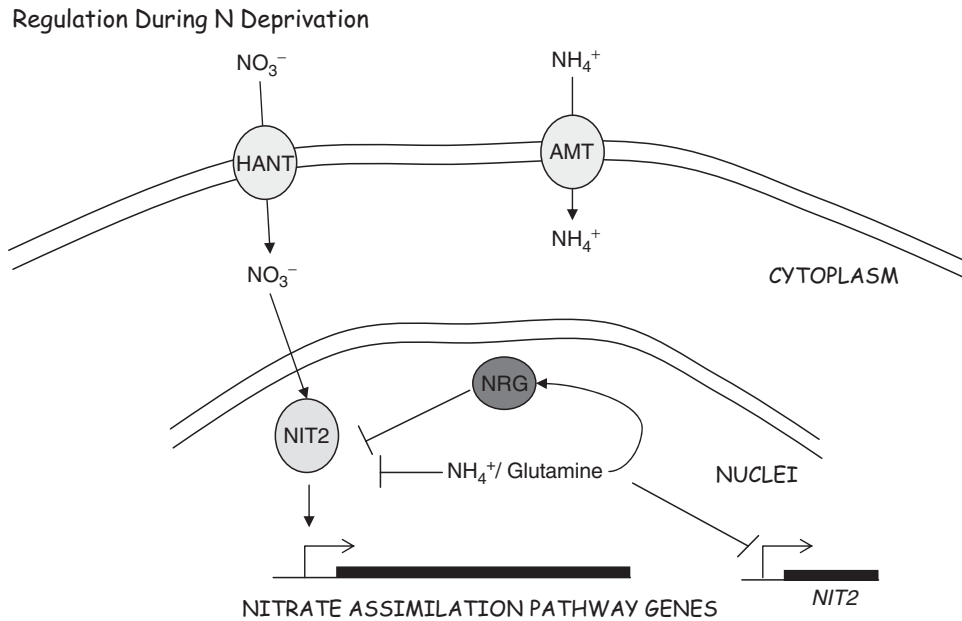

Fig. 4. Model depicting N-starvation responses. NIT2 is the master regulatory protein that controls expression of most genes involved in the  $\text{NO}_3^{2-}$  uptake and assimilation. The activation of specific promoters by NIT2 requires some intracellular  $\text{NO}_3^{2-}$ . When  $\text{NO}_3^{2-}$  is not included in the growth medium (below micromolar concentrations), the high affinity nitrate transporters (HANT) can provide trace amounts of  $\text{NO}_3^{2-}$ , which are usually enough to activate transcription from NIT2-sensitive promoters. The accumulation of NIT2 mRNA and activity is blocked by  $\text{NH}_4^+$ /glutamine and/or the products of the negative regulatory genes (NRG), which have not been defined. In the presence of both  $\text{NO}_3^{2-}$  and  $\text{NH}_4^+$ , the  $\text{NO}_3^{2-}$  assimilatory pathway is repressed.

categories: (a) those with lesions in the *NIA1* gene; (b) those unable to synthesize a functional molybdopterin cofactor; and (c) those aberrant for *NIT2*, which encodes a positive regulator for the  $\text{NO}_3^{2-}$  assimilation genes (Fernández et al. 1986). The *Chlamydomonas NIT2* gene was identified in a strain in which the gene was inactivated by the transposon *Gulliver* (Schnell and Lefebvre 1993). High *NIT2* transcript levels are observed in cells exposed to N-free medium while low levels are associated with cells grown on  $\text{NH}_4^+$ . Other loci that participate in the control of  $\text{NO}_3^{2-}$ / $\text{NO}_2^-$  assimilation are *NRG1*, *NRG2* (Prieto et al. 1996), and *FAR1* (Zhang and Lefebvre 1997), although their locations on the genome have not been determined. Mutants with lesions in the *NRG* and *FAR1* genes are defective for  $\text{NH}_4^+$  repression of  $\text{NO}_3^{2-}$  transport. The screening of thousands of insertional mutants has enabled the identification of more loci involved in the negative signal mediated by  $\text{NH}_4^+$  (Gonzalez-Ballester et al. 2005). Transformants of interest were identified based on their inability to repress the *NIA1* promoter in

the presence of  $\text{NH}_4^+$ . The sequences flanking the insertions were determined in some of the mutant strains and the genes disrupted were identified. Further analysis is required to determine the role of these loci in the signaling mechanism that controls  $\text{NH}_4^+$  repression.

### E Glutamine Synthetase

The assimilation of  $\text{NH}_4^+$  into organic compounds mostly occurs as a consequence of the activity of the GS/GOGAT system (Lam et al. 1996). GS or glutamine synthetase catalyzes the formation of glutamine through amination of glutamate, while glutamine-2-oxoglutarate amidotransferase or GOGAT catalyzes the reductive amination of 2-oxoglutarate to form glutamate, using the amide of glutamine as the N donor. Vascular plants have distinct GS isoenzymes, and in most cases GS1 is present in the cytoplasm of leaf cells and cells of non-photosynthetic tissue, while GS2 is located in chloroplasts (Guiz et al. 1979; Mann et al. 1979). The cytoplasmic and chloroplastic

GS isoforms identified in *Chlamydomonas* are similar to those of vascular plants (Chen and Silflow 1996). *Chlamydomonas* and vascular plants have two classes of GOGAT. The reductant used by one is NADH while the other uses reduced Fd (Galván et al. 1984; Marquez et al. 1984). The Fd-GOGAT is plastid-localized (Lea et al. 1990; Sechley et al. 1992) and in case of vascular plants it can account for greater than 90% of total GOGAT activity in leaves and over 60% in roots (Somerville and Ogren 1980; Suzuki and Rothstein 1997).

### III Responses to Sustained Nitrogen Starvation

During N starvation, *Chlamydomonas* cells bleach and exhibit altered metabolic activities, which includes a reduction in photosynthetic activity reflecting a loss of electron transport components such as the light-harvesting proteins and components of the cytochrome  $b_6/f$  complex (Plumley and Schmidt 1989). These responses are discussed more with respect to S and P deprivation. The cells also make proteins that facilitate scavenging of N from the environment; these proteins include N transporters (Fernández and Galvan 2007) and an extracellular L-amino acid oxidase (Vallon et al. 1993). However, sustained N deprivation in *Chlamydomonas* drives the cells into the process of gametogenesis. Vegetatively growing cells differentiate into motile gametes, and the mating type '+' and mating type '-' gametes fuse to form a zygote. The zygote represents a stage in the algal life cycle with limited metabolic activity and that can maintain viability over long periods of time under harsh environmental conditions, conditions that could include a scarcity of nutrients. Expression studies have demonstrated that a variety of genes become active as the cells develop into gametes (Merchan et al. 2001). Much of the work on gametogenesis and the mating behavior of *Chlamydomonas* has been summarized by Beck and colleagues (Huang and Beck 2003) and Goodenough et al. (2007; Lin and Goodenough 2007). Various environmental factors influence gametogenesis and zygote formation. Light is particularly important for nearly all aspects of the mating process. Light has been shown to be critical for the formation

of gametes, the reactivation of gametes after they have been kept for an extended period of time in the dark, and the germination of zygotes. Photophysiological analyses have demonstrated that blue light is critical for these processes and that the particular photoreceptor responsible for these responses is phototropin (Huang and Beck 2003; Ermilova et al. 2004). Phototropin has been studied extensively in plants where it functions to control processes including phototropism (Briggs and Huala 1999), the opening and closing of stomata (Kinoshita et al. 2003) and chloroplast movement (Kagawa et al. 2001; Kagawa and Wada 2002; Suetsugu and Wada 2007). This photoreceptor signals through an autophosphorylation that is triggered by the absorption of light by flavin chromophores that are associated with two LOV (light, oxygen, voltage) domains; the LOV domains are specialized PAS (Per, Arnt, Sim) domains (Christie et al. 2002). Interestingly, while phototropin-controlled responses in vascular plants are not generally associated with changes in gene expression and chloroplast development, the phototropin of *Chlamydomonas* has been linked to light-induced changes in the levels of transcripts encoding both light harvesting proteins and enzymes critical for chlorophyll and carotenoid biosynthesis (Im et al. 2006).

### IV Sulfur Uptake and Assimilation

Sulfur (S) is an essential macronutrient present in proteins, lipids, redox molecules such as glutathione, heavy metal binding phytochelatins and signaling molecules (Meister and Anderson 1983; Gupta et al. 1990; Schultze et al. 1992). Furthermore, there are very few S storage molecules due to which most organisms do not have a way to store large amounts of S, making it important for organisms to be sensitive to both internal and external concentration of S.

#### A Sulfur in the Environment

Available S can be scarce in some natural and agricultural settings, limiting plant productivity (Mahler and Maples 1986, 1987; Warman and Sampson 1994; Marschner 1995); severe S limitation can result in stunting of plants and a marked reduction in seed quality and yield.

In some instances S limitation has negative secondary consequences. For example, wheat fields with low available S accumulated glutamine and asparagine in the seed, which can be converted to a carcinogenic acrylamide during processing (Muttucumaru et al. 2006). In the recent past, high levels of S compounds have accumulated in some soils as a consequence of exposure to pollutants (e.g., acid rain) or treatment with fertilizers contaminated with  $\text{SO}_4^{2-}$  salts (Cole and Johnson 1977; Johnson et al. 1982; David et al. 1988; MacDonald et al. 1991). More recently, most contamination has been eliminated from fertilizers and acid rain occurrences are less frequent. Interestingly,  $\text{SO}_4^{2-}$  uptake can be important for survival of plants in soils with elevated levels of heavy metals (Nocito et al. 2006), possibly a consequence of elevated synthesis of specific thiols. This finding suggests that it may be beneficial to engineer modifications (both level of expression and kinetic features) of  $\text{SO}_4^{2-}$  transport systems into plants as part of a broad strategy for phytoremediation of metal contaminated soils.

Certain S-containing organic compounds produced by photosynthetic organisms are volatile and readily enter the biosphere. One such compound, dimethylsulfide (DMS), is generated at high rates by marine algae (Lovelock 1972; Andreae and Raemdonch 1983), primarily from the enzymatic cleavage of dimethylsulfoniopropionate (DMSP) (see Fig. 2). DMS has been estimated to be responsible for as much as 50% of global, biogenic S input into the atmosphere. The oxidation products of DMS can nucleate the formation of clouds over the oceans (Lovelock 1972; Habicht et al. 2002; Lomans et al. 2002), which strongly influences the earth's climate (Charlson et al. 1987). Atmospheric DMS would be oxidized, mostly through the generation of  $\text{OH}^-$  radicals which can be formed by UV-driven photodissociation of ozone to  $\text{SO}_2$  (Charlson et al. 1987; Kieber et al. 1996; Andreae and Crutzen 1997). The atmospheric  $\text{SO}_2$  can form  $\text{SO}_4^{2-}$  particles which behave as cloud condensation nuclei. The cloud cover generated by DMS emission lowers the light intensities that reach the ocean surface. Furthermore, rainfall from the clouds formed will return certain elements to the oceans, including N, which is often scarce in marine environments. This feedback system demonstrates a link between light and nutrients and how the

spectrum of metabolites produced by algae may result in changes in atmospheric conditions that influence the number of quanta that reach the ocean surfaces.

## B Sulfate Acquisition and Transport

The  $\text{SO}_4^{2-}$  anion, generally the most abundant S form in soils, can be taken up by plants and microbes, activated, and used for the sulfation of molecules such as lipids, polysaccharides and proteins. Activated  $\text{SO}_4^{2-}$  can also be reduced and incorporated into various compounds, including the amino acids cysteine and methionine and the antioxidant glutathione (Leustek and Saito 1999; Saito 2000).

### 1 Hydrolysis

Much of the  $\text{SO}_4^{2-}$  that enters the rhizosphere is not readily available to soil organisms as a consequence of leaching of the  $\text{SO}_4^{2-}$  through the soil matrix and tight adsorption onto the surface of soil particles. Also, a significant amount of the  $\text{SO}_4^{2-}$  released from organisms following their death may be covalently bonded to organic molecules in the form of  $\text{SO}_4^{2-}$  esters and, to a much lesser extent, as sulfonates (C-S bonds). These S-containing organic compounds can cycle into the available S pool through the action of hydrolytic enzymes that are mostly synthesized and released into the environment by microorganisms, and include aryl- and alkyl-sulfatases and sulfonatases, which cleave  $\text{SO}_4^{2-}$  from organic S-compounds. The synthesis of sulfatases is usually controlled by the level of available  $\text{SO}_4^{2-}$  in the environment. *Chlamydomonas* synthesizes cell-wall-associated arylsulfatases (ARS) that accumulate when the cells are deprived of S (Schreiner et al. 1975; de Hostos et al. 1988; de Hostos et al. 1989). The major, stable, extracellular ARS has at least three O-linked oligosaccharides and is translated as a precursor with a signal sequence that is removed as the protein is exported from the cell (de Hostos et al. 1988). The extracellular ARS location allows the enzyme to access soluble  $\text{SO}_4^{2-}$  esters in the immediate vicinity of the cell, releasing free  $\text{SO}_4^{2-}$  for assimilation. Characterization of the ARS polypeptide (de Hostos et al. 1988) led to the cloning and sequencing of

two *ARS* genes, *ARS1* and *ARS2* (de Hostos et al. 1989; Ravina et al. 2002); these genes are contiguous on the genome and arranged in a tail-to-tail orientation. However, the full *Chlamydomonas* genome sequence has identified several other putative *ARS* genes, many of which are linked, often as clusters of three genes in which two of the three are in very close proximity (Gonzalez-Ballester and Grossman 2008). This organization suggests a common evolutionary origin and that the clustered genes may have maintained similar regulatory features. It is not clear if the different *ARS* genes are distinct with respect to substrate specificity, subcellular localization or catalytic properties, and it is also not known how these genes, other than *ARS1* and *ARS2*, respond during exposure of cells to S deprivation (de Hostos et al. 1989; Ravina et al. 2002). While all of the putative *ARS* genes encode proteins with a canonical sulfatase signature, the *ARS1* and *ARS2* polypeptides are the most similar to each other (98.5% identity).

## 2 Transport Across the Plasma Membrane

*Chlamydomonas* has a number of different energy-dependent  $\text{SO}_4^{2-}$  transporters (Yildiz et al. 1994) that have different kinetic characteristics. Whole genome sequence analyses coupled to expressed sequence tag (EST) information has identified six putative eukaryotic-type  $\text{SO}_4^{2-}$  transporters encoded on the *Chlamydomonas* genome. Three of these transporters are of the plant type ( $\text{H}^+/\text{SO}_4^{2-}$  co-transporters) and have been designated SULTR1, SULTR2, and SULTR3. The most divergent of these  $\text{H}^+/\text{SO}_4^{2-}$  co-transporters is SULTR3. All of these transporters have a STAS domain, a C-terminal regulatory domain present on most transporters in the SLC26A family of anion transporters. Several  $\text{H}^+/\text{SO}_4^{2-}$  co-transporters have been identified in vascular plants including *Stylosanthes hamata* (Smith 1995), *Arabidopsis thaliana* (Takahashi et al. 1997, 2000), barley (Smith et al. 1997; Vidmar et al. 1999), *Brassica oleracea* (Buchner et al. 2004) and *Lycopersicon esculentum* (Howarth et al. 2003). Some of these transporters have been shown to have  $\text{SO}_4^{2-}$  transport function based on their ability to rescue the methionine-dependent phenotype of a yeast mutant null for the major  $\text{SO}_4^{2-}$  transporters, *Sul1*

and *Sul2*. The genes encoding most *Arabidopsis*  $\text{SO}_4^{2-}$  transporters have been cloned, characterized, and the individual genes have been shown to be expressed in specific tissue types, such as roots or leaves, or for the encoded protein to function in specific membranes. Some of these transporters are associated with the plant plasmamembrane of root hairs, epidermal and cortical cells (Shibagaki et al. 2002; Yoshimoto et al. 2002), while others are associated with the tonoplast (Kataoka et al. 2004b) and the vasculature (Kataoka et al. 2004a). Expression of at least some of the genes encoding these  $\text{SO}_4^{2-}$  transporters is controlled at both transcriptional and post-transcriptional levels (Yoshimoto et al. 2007).

Like most nutrient transporters in eukaryotes, the  $\text{H}^+/\text{SO}_4^{2-}$  transporters are each comprised of 10–14 predicted transmembrane domains (TMD), that represent a duplication of usually six TMDs in which one set of the six is oriented in the opposite direction relative to the other (generating a palindrome-like orientation) along the polypeptide chain. These transporters also contain a C-terminal domain that protrudes into the cytoplasm of the cell that has been designated the sulfate transporter and anti sigma antagonist domain (STAS) (Aravind and Koonin 2000). The STAS domain has also been identified as a component of other polypeptides, including one with characteristics of a photoreceptor (Crosson et al. 2003). Interestingly, there are both sequence (Duncan et al. 1996) and structural (Rost et al. 1997) similarities between the STAS domain and the *Bacillus subtilis* anti-sigma factor antagonist SpoIIAA (required for sporulation in *B. subtilis*). SpoIIAA is a regulator of *B. subtilis* sporulation. During its interaction with SpoIIAB (anti-sigma factor), it undergoes a cycle of phosphorylation-dephosphorylation that controls the heterologous protein-protein interaction and is part of the regulatory mechanism that modulates the activity of the sigma factor (Ho et al. 2003). Furthermore, the STAS domain appears to be critical for the normal function of many anion transporters. In plants it has been shown that the STAS domain is critical for both the activity and biogenesis of  $\text{SO}_4^{2-}$  transporters (Shibagaki and Grossman 2004, 2006; Rouached et al. 2005), while the STAS sequence is also critical for human DRA  $\text{Cl}^-/\text{HCO}_3^-$  antiporter function (Chernova et al.



2003). Lesions in the STAS sequences of human anion transporters can result in various diseases including diastrophic dysplasia and Pendred's syndrome (Superti-Furga et al. 1996; Everett et al. 1997; Everett and Green 1999; Usami et al. 1999; Ko et al. 2002). Furthermore, like the anti-sigma factor antagonist protein of bacteria (Duncan et al. 1996), nucleotide triphosphates bind to the STAS domain (Najafi et al. 1996) and may modulate its function via a phosphorylation-dephosphorylation cycle (Rouached et al. 2005).

The three animal-like,  $\text{Na}^+/\text{SO}_4^{2-}$  co-transporters encoded on the *Chlamydomonas* genome are designated SLT1, SLT2, and SLT3. The genes for two of these transporters, *SLT2* and *SLT3*, are arranged in tandem and in the same orientation on the genome. Interestingly, these putative transporters also have significant sequence similarity to the sulfur acclimation regulatory element SAC1, which controls many of the responses of *Chlamydomonas* to S-deprivation conditions (Davies et al. 1996). While the  $\text{Na}^+/\text{SO}_4^{2-}$  transporters do not have a STAS domain, they contain TrkA-C domains. The Trk sequences have been associated with potassium transport and may bind  $\text{NAD}^+$ , but no definitive physiological or regulatory function has been assigned to these domains at this point (Tucker and Fadool 2002; Kraegeloh et al. 2005)

While neither functionality nor cellular localizations for the *Chlamydomonas* putative  $\text{SO}_4^{2-}$  transporters have been conclusively demonstrated, recent work shows that the levels of the *SLT* and *SULTR* mRNAs can be dramatically altered by S availability. Furthermore, *SULTR2* and *SLT2* proteins accumulate to high levels in the membranes when the cells are starved for S (Pootakham and Grossman 2009). Changes in levels of both transcripts and proteins associated with  $\text{SO}_4^{2-}$  transport activity in *Chlamydomonas* is in accord with analyses of transporter activity as the cells transition from S-replete to S-starvation conditions. Initial studies defining the kinetics of  $\text{SO}_4^{2-}$  transport into *Chlamydomonas* cells have demonstrated that the maximum velocity ( $V_{max}$ ) and the substrate concentration at which  $\text{SO}_4^{2-}$  transport was at half-maximum velocity ( $K_{1/2}$ ) changed significantly when S-replete cells were transferred to medium devoid of S; there was a tenfold increase in the  $V_{max}$  for  $\text{SO}_4^{2-}$ , while

the  $K_{1/2}$  decreased by approximately sevenfold (Yildiz et al. 1994). Initial changes in transport characteristics and the levels of the specific transport proteins could be detected within an hour of transferring cells from S-replete to S-deprivation conditions and were blocked when cycloheximide, an inhibitor of translation on 80S cytoplasmic ribosomes, was included in the medium at the time of cells transfer; chloramphenicol, an inhibitor of translation on 70S chloroplast ribosomes, had little effect on the development of transporter activity. Hence, the development of new transport activities following S deprivation requires translation on 80S cytoplasmic ribosomes, and correlates with changes in the levels of transporter proteins (Pootakham and Grossman 2009).

### 3 Transport into the Chloroplast

Once in the cytoplasm,  $\text{SO}_4^{2-}$  must enter the plastid to be reduced by electrons generated by photosynthetic electron transport. Initially, a single *Chlamydomonas* gene designated *SULP* (sulfate transporter plastid) was identified that was hypothesized to encode a subunit of a putative  $\text{SO}_4^{2-}$  transporter associated with chloroplasts (Chen et al. 2003; Chen and Melis 2004). The *SULP* protein is predicted to be a transmembrane protein with strong similarity to CysT, which is the hydrophobic, integral membrane component of a bacterial ABC transporter. Both *SULP* mRNA and protein increase when *Chlamydomonas* cells are deprived of S, and a *sulP* antisense strain exhibited reduced  $\text{SO}_4^{2-}$  uptake capacity, lower levels of photosynthetic activity (measured as light-saturated rates of  $\text{O}_2$  evolution and photosystem II and RuBP carboxylase activity), and signs of S deficiency even when a moderate concentration of  $\text{SO}_4^{2-}$  was included in the medium (Chen and Melis 2004; Chen et al. 2005). In this study, no *sulP* antisense transformants with a large reduction in the level of *SULP* transcripts were isolated, suggesting that a complete loss of gene activity results in lethality and that this transporter represents the major path for  $\text{SO}_4^{2-}$  import into *Chlamydomonas* chloroplasts.

Other genes encoding putative components of the chloroplast  $\text{SO}_4^{2-}$  transporter have now been identified (Melis and Chen 2005). These include genes for a second transmembrane protein

(SULP2), a stromal-targeted nucleotide binding protein (SABC) and a substrate binding protein (SBP). The SULP and SULP2 polypeptides each contain seven transmembrane domains with one or two large hydrophilic loops that protrude into the cytosol of the cell. Genes encoding similar subunits of a putative bacterial type  $\text{SO}_4^{2-}$  transporter have been identified on the nuclear genome of the diatom *Thalassiosira pseudonana* (Armbrust et al. 2004), on chloroplast genomes of the liverwort *Marchantia polymorpha* (Accession X04465) (Ohyama et al. 1988) and the hornwort *Anthoceros formosae* (accession AB086179) (Kugita et al. 2003), and on both plastid and nuclear genomes of the red alga *Cyanidioschyzon merolae* (accessions AY286123 and AB002583) (Ohta et al. 2003). Indeed, genes encoding potential bacterial-type  $\text{SO}_4^{2-}$  transporter subunits have been identified on chloroplast genomes of several algae including *Nephroselmis olivacea* (Turmel et al. 1999), *Mesostigma viride* (Lemieux et al. 2000), *Zygnema circumcarinatum* (Accession Ay958086) (Turmel et al. 2005), *Chara vulgaris* (Turmel et al. 2006) and *Chlorella vulgaris* C-27 (Accession AB001684) (Wakasugi et al. 1997). These findings imply that the transport of  $\text{SO}_4^{2-}$  into algal chloroplasts requires a bacterial-type ABC (ATP binding cassette) transporter, and that genes encoding the various subunits of this transporter are often located on the plastid genome. However, in a number of cases, genes encoding some of the subunits have been transferred from the genome of the original endosymbiont to the nuclear genome of the original host. It will be of interest to determine how the nuclear- and plastid-encoded subunits of chloroplast envelope  $\text{SO}_4^{2-}$  transporter are coordinately regulated and to explore the evolutionary histories of the different subunits among different photosynthetic organisms.

### C Reductive Assimilation

Most  $\text{SO}_4^{2-}$  that is transported across the plasmamembrane is activated by ATP sulfurylase (gene and protein designation ATS), yielding the product adenosine 5'-phosphosulfate (APS). Plants contain both chloroplast and cytosolic forms of ATS (Schürmann and Brunold 1980; Lunn et al. 1990; Rotte and Leustek, 2000). The first isolation of a plant ATS gene was from potato (Klonus et al. 1994). In *Arabidopsis* there are three puta-

tive plastidic and one putative cytosolic ATS isoform (Leustek et al. 1994; Murillo and Leustek 1995; Logan et al. 1996; Hatzfeld et al. 2000). *Chlamydomonas* appears to have an *ATS1* and *ATS2* gene (Yildiz et al. 1996), both of which encode proteins with a potential transit peptide. These findings suggest that the activation of  $\text{SO}_4^{2-}$  is exclusively in *Chlamydomonas* chloroplasts, although biochemical confirmation of this conclusion is required. The *ATS1* transcript has been shown to increase in abundance during S starvation (Yildiz et al. 1996; Ravina et al. 2002), which is supported by microarray data (Zhang et al. 2004).

APS generated by the ATS reaction can serve as substrate for  $\text{SO}_4^{2-}$  reduction or undergo a further phosphorylation by APS kinase (phosphosulfate kinase; gene and protein designation APK) to yield 3'-phosphoadenosine 5'-phosphosulfate (PAPS) (Arz et al. 1994; Lee and Leustek 1998). The enzyme APS sulfotransferase or reductase (APR, gene designation *APR1*) (Gutierrez-Marcos et al. 1996; Setya et al. 1996; Ravina et al. 2002) catalyzes the reduction of the  $\text{SO}_4^{2-}$  associated with APS to sulfite. These reductases are present in plastids (Rotte and Leustek 2000), and the source of reductant for the enzyme is probably reduced glutathione (Bick et al. 1998; Prior et al. 1999). APR mRNA increases in response to S starvation, suggesting that a key juncture for the control of S assimilation occurs at the point at which APS interacts with either APS kinase or APR (Gutierrez-Marcos et al. 1996). There appears to be single *APR* and *APK* genes in *Chlamydomonas*, based on the full genome sequence. The product of the kinase reaction, PAPS, can serve as a substrate for sulfotransferases involved in sulfation of various metabolites including flavanols, choline and glucosides (Varin et al. 1997).  $\text{SO}_3^{2-}$  generated in the APR reaction is reduced to sulfide by plastid  $\text{SO}_3^{2-}$  reductase (gene and protein designation SIR), using reduced ferredoxin as the electron donor (Yonekura-Sakakibara et al. 2000). *SIR* genes have been identified in plants (Bruhl et al. 1996; Bork et al. 1998; Yonekura-Sakakibara et al. 2000) and in *Chlamydomonas*; there is elevated accumulation of *SIR* mRNA in response to S deprivation (Zhang et al. 2004). Based on the full genome sequence, there are multiple *SIR* genes in *Chlamydomonas*, probably two ferredoxin types and one bacterial type

(*SIR1*, *SIR2* and *SIR4*). Once sulfide is generated, it combines with O-acetylserine (OAS) to form cysteine, in a reaction catalyzed by O-acetylserine (thiol) lyase (protein OASTL, gene *ASL*). The OASTL enzyme has been localized to the cytosol, chloroplast and mitochondrion in *Arabidopsis* (Lunn et al. 1990). In plants the *ASL* gene family encodes specific OASTL isoforms (Romer et al. 1992; Saito et al. 1992; Youssefian et al. 1993; Saito et al. 1994; Gotor et al. 1997; Hesse et al. 1999). The *Chlamydomonas* genome has four putative *ASL* genes (with two transcripts from one of the genes) and at least one that is responsive to S-deprivation (Ravina et al. 1999). While at least one OASTL isoform is predicted to be chloroplast localized and another mitochondria localized, no biochemistry has been done to confirm the putative locations.

Serine acetyltransferase (protein SAT; gene *SERAT*) functions in the cytosol, chloroplast and mitochondrion of plants to catalyzes the formation of OAS (Ruffet et al. 1995), the substrate for OASTL. The cytosolic isozyme of SAT is controlled by feedback inhibition by micromolar concentrations of cysteine (Saito et al. 1995; Noji et al. 1998, 2001; Noji and Saito 2002). In watermelon plants, S starvation causes a small increase in the level of the *SERAT* transcript that encodes the plastid isoform of SAT (Saito et al. 1997). The SAT is part of the cysteine synthase complex, which includes SAT, OASTL and four molecules of pyridoxal 5'-phosphate (Bogdanova and Hell 1997; Droux et al. 1998). Control of cysteine synthase activity defines a critical juncture in the formation of S-containing amino acids. *Arabidopsis* has five *SERAT* genes encoding proteins that differ in abundance, and changes in levels of *SERAT* transcripts can be triggered by S starvation. Furthermore, *Arabidopsis* SAT proteins exhibit different sensitivities to L-cysteine and have been localized to different cellular compartments (Kawashima et al. 2005). *Chlamydomonas* has at least two *SERAT* genes, with both encoding proteins containing putative presequences that probably target the protein to the chloroplast. The transcript from at least one of these genes appears to increase in response to S starvation (Ravina et al. 2002).

Methionine is synthesized from cysteine and O-phosphohomoserine (OPH) by three consecutive reactions catalyzed by cystathionine

$\gamma$ -synthase, cystathionine  $\beta$ -lyase and methionine synthase (Ravanel et al. 1998a, b). Cystathionine  $\gamma$ -synthase, which catalyzes cystathionine formation (Wallsgrave et al. 1983; Ravanel et al. 1995a, b), is chloroplast localized and its activity is controlled by OPH and S-adenosylmethionine (SAM) availability. However, OPH can serve as substrate for both cystathionine  $\gamma$ -synthase and threonine synthase, with S conditions determining the metabolic fate of OPH. During S-replete growth the levels of SAM are high and the activity of threonine synthase would be favored over that of cystathionine  $\gamma$ -synthase (Curien et al. 1998). During S deprivation, the SAM concentration in the cell is diminished, the activity of threonine synthase declines and more of the OPH is converted to methionine via the cystathionine  $\gamma$ -synthase reaction (Ravanel et al. 1998a, b). Interestingly, the mRNA encoding *Arabidopsis* cystathionine  $\gamma$ -synthase is controlled at the level of stability; methionine or a methionine metabolite triggers destabilization of the transcript (Chiba et al. 1999). *Chlamydomonas* has a single cystathionine  $\gamma$ -synthase gene. Cystathionine  $\beta$ -lyase, which generates homocysteine from cystathionine (Wallsgrave et al. 1983; Droux et al. 1995), is single copy in *Arabidopsis*, and the encoded enzyme has properties similar to that of the bacterial enzyme and is likely targeted to the chloroplast (Droux et al. 1995; Ravanel et al. 1995a, b, 1996, 1998a, b). A single gene for cystathionine  $\beta$ -lyase has been identified on the *Chlamydomonas* genome. The methylation of homocysteine by methionine synthase generates methionine. There are two methionine synthase genes in *E. coli*; one encodes a cobalamin (vitamin B<sub>12</sub>)-dependent enzyme while the other encodes a cobalamin-independent enzyme. Animals have maintained the cobalamin-dependent form while plants have the cobalamin-independent form. Interestingly, *Chlamydomonas* has both forms and expression of the cobalamin-independent form may be controlled by a riboswitch mechanism in which cobalamin binds the transcript, leading to translation arrest (Croft et al. 2005, 2006; Grossman et al. 2007).

Algal and plant cells also synthesize glutathione (GSH =  $\gamma$ -Glu-Cys-Gly), a dominant non-protein thiol (Rennenberg 1982). GSH serves as a major antioxidant (Noctor et al. 1998; Foyer and Fletcher 2001) and may also be important

in regulating the uptake of  $\text{SO}_4^{2-}$  by plant roots (Herschbach and Rennenberg 1994; Lappartient and Touraine 1996; Hartmann et al. 2004). GSH is a redox buffer in cells (Foyer and Halliwell 1976; Law et al. 1983; Kunert and Foyer 1993; Meister 1994), serves as a substrate for GSH-S-transferases which function in the detoxification of xenobiotics (Marrs 1996), and serves as a precursor in the synthesis of phytochelatins, small peptides that enable plants to cope with environmental contamination by heavy metals (Rauser 1987; Scheller et al. 1987; Grill et al. 1989). The synthesis of GSH, which is catalyzed by  $\gamma$ -glutamylcysteine synthetase and GSH synthetase, occurs in plastids. Functional complementation of *E. coli* mutants facilitated the isolation of *Arabidopsis* genes encoding  $\gamma$ -glutamylcysteine synthetase and GSH synthetase (May and Leaver 1994; Rawlins et al. 1995). *Chlamydomonas* has a single gene encoding GSH synthetase.

## V Control of Sulfur Starvation Responses

Most organisms exhibit a suite of responses when their growth becomes nutrient limited. These responses highlight a number of strategies that enable the cells to adjust to changing S levels.

### A Specific and General Responses

The nutrient limitation responses have been divided into two classes, those that are 'specific' and those that are 'general'. General responses represent changes in cell growth/division and metabolism that accompany conditions that severely limit the growth potential of the cells. These responses include the cessation of cell division, the accumulation of storage carbohydrates and the modulation of cellular metabolism. Of all of these responses, that of photosynthesis has been most extensively studied. During nutrient limitation (S, P and N) the photosynthetic activity in *Chlamydomonas* declines through a variety of mechanisms (Plumley and Schmidt 1989; Peltier and Schmidt 1991; Wykoff et al. 1998). Mutant strains unable to suppress photosynthetic electron transport in response to nutrient limitation die rapidly (Davies et al. 1996), suggesting that modulation of photosynthetic electron flow is critical

for survival as the growth potential of the cell declines. Furthermore, reduced photosynthetic activity can lead to the development of anoxia in the cultures, which can trigger fermentation metabolism and expression of the two iron-only hydrogenases that catalyze  $\text{H}_2$  production (Forestier et al. 2003). This finding is being exploited by several researchers to study biocatalytic  $\text{H}_2$  production in *Chlamydomonas* cultures depleted for S (Zhang and Melis 2002; Fouchard et al. 2005; Ghirardi et al. 2007; Melis 2007). Developing a better understanding of the consequences of S deprivation and anoxia (Mus et al. 2007) are providing new insights into metabolisms that facilitate the generation of  $\text{H}_2$ .

Specific nutrient-deprivation responses are those that are associated exclusively with deprivation for a single nutrient. For S deprivation, they are mostly associated with activities that promote scavenging of extracellular S and the recycling of intracellular S. These responses involve the production of specific  $\text{SO}_4^{2-}$  transporters and hydrolytic enzymes that cleave esterified  $\text{SO}_4^{2-}$  from organic compounds in the environment, intracellular recycling of S-containing compounds (Ferreira and Teixeira 1992), and replacement of proteins with a high S amino acid content with functionally analogous proteins containing few S amino acids; such proteins include the isoflavone reductase-like protein IRL of maize (Petrucco et al. 1996), the extracellular polypeptides, designated ECPs, of *Chlamydomonas* (Takahashi et al. 2001) and the  $\beta$ -conglycinin storage protein of soybean (Naito et al. 1994; Kim et al. 1999). While high levels of S metabolites block  $\text{SO}_4^{2-}$  assimilation, S deprivation triggers increased assimilatory activity (Bolchi et al. 1999; Lappartient et al. 1999; Lee and Leustek 1999). This agrees with findings demonstrating glutathione repression of genes encoding a number of enzymes of the S assimilation pathway (Lappartient et al. 1999), and that OAS stimulated S assimilation in both bacteria (Kredich 1992) and plants (Smith et al. 1997; Koprivova et al. 2000; Kopriva 2006).

### B Genes Responsive to Sulfur Deprivation

Numerous *Chlamydomonas* genes with unknown function respond to S deprivation (Zhang et al. 2004, 2008); many are associated with elevated



transcript levels when the cells experience S deprivation. Genes of known function that are upregulated during S deprivation encode proteins involved in hydrolyzing  $\text{SO}_4^{2-}$  from organic compounds (*ARS1*, *ARS2*), transporters of  $\text{SO}_4^{2-}$  (*SULTR2*, *SLT1* and *SLT2*) and enzymes needed for the assimilation of  $\text{SO}_4^{2-}$  into amino acids (*ATS*, *APR*, *ASL* and *SERAT*) (Ravina et al. 2002; Davies et al. 1994; Zhang et al. 2004; Eberhard et al. 2006; Gonzalez-Ballester and Grossman, 2008). In addition, two prominent extracellular polypeptides, ECP76 (76 kDa) and ECP88 (88 kDa), are synthesized in response to S deprivation (Takahashi et al. 2001). The genes encoding these polypeptides are rapidly activated following the imposition of S-limitation. Furthermore, ECP76 and ECP88 mRNAs are rapidly degraded (half-life of <10 min) following addition of  $\text{SO}_4^{2-}$  to S-deprived cells (Takahashi et al. 2001). The amino acid sequences of ECP76 and ECP88 have features that resemble cell wall proteins, but between them (mature polypeptides) there is only a single S-containing amino acid. Hence, the protein-rich *Chlamydomonas* cell wall is likely tailored for conservation of S-containing amino acids during S deprivation. These cell wall-associated changes may also reflect conditions in which the cells are no longer elongating and dividing (e.g., changes in extensibility and elasticity of the wall).

Microarray studies with a ~3,000 element cDNA array demonstrated that levels of transcripts from over 140 genes in wild-type cells increased by four-fold or more following elimination of S from the medium while approximately 40 transcripts decreased to below 25% of the level observed in nutrient-replete cells (Zhang et al. 2004). Many of the transcripts that were elevated during S deprivation were previously demonstrated to encode S deprivation-induced proteins (e.g., ARS, ECP76,  $\text{SO}_4^{2-}$  assimilation proteins). However, others encoded novel polypeptides of the light harvesting family (e.g., LHCSR2), enzymes involved in scavenging reactive oxygen species and putative regulatory elements.

### C Genes Controlling Sulfur Deprivation Responses

The responses elicited in *Chlamydomonas* during S-starvation require efficient mechanisms for

sensing S availability and activating a signaling pathway(s). Recent studies in plants have identified a transcription factor that appears to bind the promoters of genes that become active as the organism becomes S starved (Maruyama-Nakashita et al. 2006); but there is a dearth of information concerning the responses of vascular plants to S deprivation.

The acclimation of *Chlamydomonas* to S deprivation exhibits at least two regulatory tiers; one that is elicited rapidly following the imposition of S deprivation and the other that is observed at a somewhat later time. These two tiers are also distinguished by the finding that the first is independent of protein synthesis while the second is protein synthesis dependent. The transcripts that most rapidly accumulate following the imposition of S deprivation encode the  $\text{SO}_4^{2-}$  transporters while those that accumulate later encode ARS, the ECPs, enzymes of the  $\text{SO}_4^{2-}$  assimilatory pathway and SBDP. Furthermore, a number of regulatory elements in *Chlamydomonas* have been demonstrated to be critical for the acclimation of cells to S starvation. Identification of regulatory elements was facilitated by strategies in which thousands of insertional mutants were screened for their ability to acclimate to S deprivation conditions based on ARS activity (assayed by hydrolysis of the colorimetric reagent 5-bromo-4-chloro-3-indolyl  $\text{SO}_4^{2-}$ , also called X- $\text{SO}_4^{2-}$ ) (Davies et al. 1994, 1996; Pollock et al. 2005; Gonzalez-Ballester et al. 2008). Some mutant strains were unable to synthesize ARS following S deprivation, others produced low level ARS activity and still others synthesized ARS constitutively (the activity was observed in cells maintained on  $\text{SO}_4^{2-}$ -containing medium). Potential mutants were examined for co-segregation of the mutant phenotype with the 'tag' (either the *ARG7* or *aphVIII* gene for paramomycin resistance), and for those in which the mutant phenotype was a consequence of the insertion, the disrupted gene was identified and in a number of cases, rescue of the mutant phenotype by the wild-type gene was established.

The first S acclimation mutant isolated was designated *sac1* (S acclimation). This mutant does not synthesize active ARS, exhibits abnormal  $\text{SO}_4^{2-}$  uptake in response to S deprivation, and exhibits no or very low induction of most genes associated with  $\text{SO}_4^{2-}$  acquisition and assimilation (Davies et al. 1996; Yildiz et al. 1996; Takahashi

et al. 2001; Ravina et al. 2002; Zhang et al. 2004). Furthermore, transcripts from genes associated with photosynthetic electron transport and the amelioration of damaging effects elicited by reactive oxygen species (ROS) are elevated during S deprivation, and appear to be SAC1 regulated. Other transcripts under the control of SAC1 are involved in restructuring of the photosynthetic apparatus during S deprivation. For example, the *LHCSR2* transcript (member of *LHC* gene family; protein ID 184731) which accumulates during high light and other stress conditions (Savard et al. 1996), is also elevated during acclimation of the cells to S deprivation (Zhang et al. 2004). Furthermore, transcripts encoding two putative chloroplast chaperones show a marked increase in accumulation in the *sac1* mutant, which may reflect an extreme stress response associated with cells that are unable to acclimate to changing S conditions; *sac1* mutant cells die within 2d of being placed into medium devoid of S (Davies et al. 1996). This death response is associated with Photosystem II electron flow, suggesting that modification of photosynthetic electron transport during S deprivation is critical for cell survival. An inability to modify the photosynthetic machinery would cause hyper-reduction of the electron transport chain (e.g., PQ pool), which could promote ROS generation and as a consequence, extensive cellular damage.

The SAC1 protein is strikingly similar to  $\text{Na}^+/\text{SO}_4^{2-}$  transporters (*SLT* genes) which are found in animal cells (Davies and Grossman 1998; Pootakham and Grossman 2009), but it appears to have a regulatory function. A similar situation has been reported for Snf3p, which is a yeast hierarchical regulator that resembles the hexose transporter (Ozcan et al. 1996, 1998; Rodriguez et al. 2003). These observations raise the possibility that polypeptides that originally functioned to bind and transport specific substrates into the cell may have evolved into regulatory elements critical for sensing extracellular or intracellular  $\text{SO}_4^{2-}$  levels. The binding of  $\text{SO}_4^{2-}$  to these molecules would trigger a signal transduction cascade that could both modulate nutrient acquisition activities and tune metabolism to the cell's growth potential.

Like many of the animal type  $\text{Na}^+/\text{SO}_4^{2-}$  transporters, SAC1 contains TrkA-C domains. These domains occur in many proton channel proteins as one or two tandem repeats, and are proposed

to facilitate homodimer formation that establishes a cleft between two lobes of the transport complex (Anantharaman et al. 2001; Barabote et al. 2006; Nanatani et al. 2007). For SAC1, two TrkA-C domains are positioned in the central region of the protein, associated with a soluble loop that protrudes into the cytoplasm of the cell. They could play a role in sensing or transducing intracellular signals. The SLT transport proteins of *Chlamydomonas*, like SAC1, have TrkA-C domains, but they have four tandem TrkA-C repeats rather than two.

A second mutant that has been characterized is designated *sac3*. This mutant exhibits low-level constitutive ARS activity in S-replete medium, but like wild-type cells, accumulates increased ARS activity following its transfer to medium devoid of S. Furthermore, low level accumulation of transcripts from S-responsive genes during nutrient-replete growth, conditions under which these transcripts are not normally detected, is observed in the *sac3* mutant. The levels of these transcripts can be further elevated when the cells are deprived of S. These results suggest that the SAC3 protein is necessary for repression of *ARS* and other genes that are normally only activated following exposure of the cells to S-deprivation. SAC3 may also positively regulate  $\text{SO}_4^{2-}$  transport activity (post-transcriptionally) (Davies et al. 1999), and allow for a decrease in chloroplast transcriptional activity during S starvation, possibly a consequence of inactivation of the chloroplast RNA polymerase sigma factor SIG1 (Irihimovitch and Stern 2006). The *SAC3* gene encodes a putative serine-threonine kinase that belongs to the plant specific SNRK2 family (Boudsocq et al. 2007; Fujii et al. 2007); the SAC3 protein has been renamed SNRK2.2.

Recently a new mutagenesis (lesions caused by insertion of the *aphVIII* gene; transformants selected for paromomycin resistance) was performed to identify strains defective for the synthesis of active ARS during S deprivation. This mutagenesis yielded several new strains null for ARS activity (Pollock et al. 2005). Two allelic mutants, *ars11* and *ars44*, had insertions in a gene encoding a serine-threonine protein kinase which, like SNRK2.2, is a member of the SNRK2 family of plant kinases and has been designated SNRK2.1. The *ars11* mutant has a phenotype that

is similar to that of *sac1*; there is essentially no activation of S-deprivation responsive genes following transfer of the cells to S-depleted medium, but the phenotype is even more severe than that of *sac1*. The *ars44* mutant exhibits a phenotype that is less severe than that of either *ars11* or *sac1* (e.g., low level ARS activity is observed in S-deprived cells). The phenotypic difference between *ars11* and *ars44* can be explained by the site at which the *AphVIII* gene inserted into the *SNRK2.1* gene. For the *ars11* mutant, the genetic marker inserted into exon 6, which resulted in a null phenotype (truncated mRNA), while for the *ars44* mutant the genetic marker inserted into intron 7 and a wild-type, full-length transcript could be detected, although it is present at much lower levels than in parental cells. These findings demonstrate a major role of *SNRK2.1* in the control of S-deprivation responses in *Chlamydomonas*, and the importance of a phosphorylation cascade(s) in the responses of the cell to nutrient deprivation (Gonzalez-Ballester et al. 2008).

Another mutant, designated *ars401*, also exhibits essentially no ARS activity during S-starvation. This strain is interrupted for a gene encoding a putative guanylyl cyclase (*ars401*). There are over 50 putative guanylyl-adenylyl cyclases encoded on the *Chlamydomonas* genome (Merchant et al. 2007), and up to this point cyclic nucleotides have only been linked to mating processes (Pasquale and Goodenough 1987). A mutant affected in a member of the E3 ubiquitin ligase complex (Skp1/Cullin/F-box protein-type, similar to SGT-1), which is involved in protein degradation, also makes little active ARS when transferred to medium lacking S; the mutant has been complemented with a cDNA encoding the interrupted, SGT-1-like protein. For some of the other mutants that have been isolated (Pollock et al. 2005), both linkage and complementation analyses are still required. Double mutant analyses will help determine possible epigenetic relationships among the different genes identified by the screen. While the genetic screens have been very fruitful in the identification of key proteins required for acclimation of *Chlamydomonas* to S deprivation, only a few of the mutants are represented by multiple alleles, suggesting that other genes important for normal S-deprivation responses in *Chlamydomonas* remain to be identified.

## D Sequence of Regulatory Events

Below we summarize information concerning the regulation of S-deprivation responses into a potential sequence of regulatory events that accompany the acclimation of *Chlamydomonas* cells to S deprivation; this is also summarized in a model shown in Fig. 5.

- a. S-deprivation conditions are perceived by SAC1, on the cytoplasmic membranes of the cell. Deprivation may be sensed from outside the cell, inside the cell or both. Some evidence suggests that there must be an internal signal that triggers activation of S-deprivation responses (Moseley et al. 2009), but does not exclude the importance of external signals.
- b. SAC1 interacts either directly or indirectly with *SNRK2.1* (possibly through *SNRK2.2*) to trigger a phosphorylation cascade that would activate genes associated with S deprivation. The first genes to be activated are those encoding the transporters, *SULTR2* and *SLT1* and *SLT2*. Within this same time frame, the transcripts for other putative transporters are down-regulated (e.g., *SULTR1* and *SLT3*); these transporters are likely to have low affinity characteristics that are most appropriate when there is an abundance of  $\text{SO}_4^{2-}$  in the environment. Other genes, including some regulatory elements, may be activated immediately following the imposition of stress conditions as well. The transcription factor directly involved in promoter binding during the first tier of regulation has not been identified (although there are some candidates among our collection of insertion mutants defective for ARS expression).
- c. Protein synthesis that occurs soon after S deprivation is required for controlling genes that are activated slightly later in the S-deprivation-acclimation program. The genes that become active during this second tier of regulation include *ARS1*, *ARS2*, *ECP76*, *ECP88*, *SBDP* and a number of genes involved in the assimilation of  $\text{SO}_4^{2-}$ . Activation could be elicited through a novel transcription factor and/or may require the  $\text{SO}_4^{2-}$  transporter proteins that are synthesized during the first tier of the regulatory process; e.g. one of the newly synthesized transporters may serve to signal the system that  $\text{SO}_4^{2-}$  is still limiting, although this conjecture is highly speculative.
- d. The signaling associated with the second tier of gene activation may be amplified through the action of cyclic nucleotides, and the *SNRK2.2* protein kinase may also be modified such that repression of gene

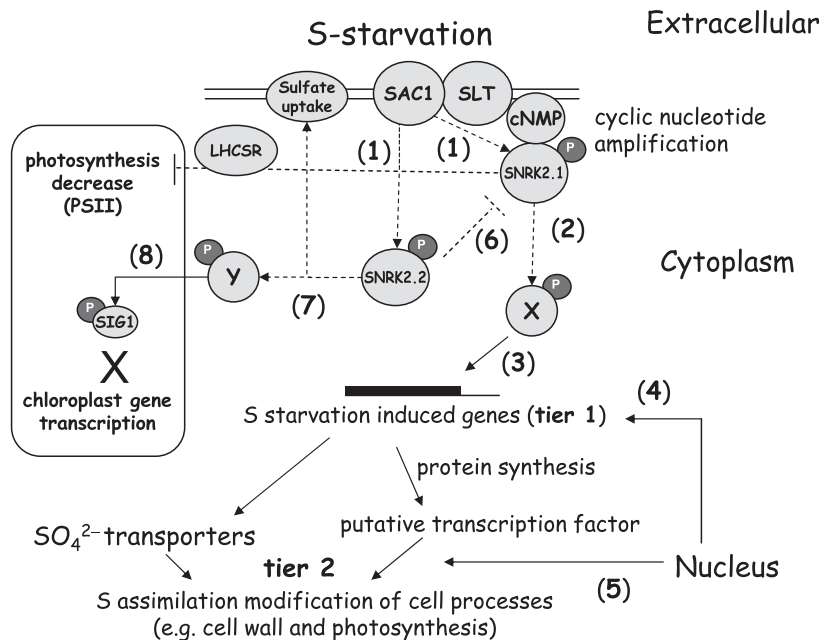

**Fig. 5.** Model depicting S-deprivation responses. The S status of the environment is sensed by SAC1. SAC1 interacts with SNRK2.1 (1) either directly or indirectly (possibly through SNRK2.2), triggering a phosphorylation cascade (2). The process also involves a guanylyl/adenylyl cyclase (cNMP), which may serve as an amplifier of the reaction. Other proteins, such as the SLT and/or SULTR transporters may interact also with SAC1 in the plasma membrane to control both transport and signaling through SNRK2.1. Once SNRK2.1 is activated, it may phosphorylate an unidentified transcription factor (X), which elicits elevated or depressed activity from S-responsive genes (3), including those encoding the  $\text{SO}_4^{2-}$  transporters. Proteins synthesized during this first 'tier' (4) of regulation are required for the activation of genes during a second tier (5) of regulation (which may require a second transcription factor and/or signaling through one of the newly synthesized transporters). Second tier regulation involves activation of genes encoding enzymes of the  $\text{SO}_4^{2-}$  assimilation pathway and proteins required for restructuring of metabolic processes (e.g. LHCSR). However, the activity of SNRK2.1 may not be totally dependent on SAC1. SNRK2.2 may inhibit SNRK2.1 during S-replete conditions (e.g., through a second phosphorylation of a specific site on SNRK2.1), which completely suppresses S-responsive gene expression. In addition, during S-starvation conditions, SNRK2.2 might signal to a putative plastid kinase (6) that in turn activates a system involved in proteolysis of SIG1 (the sigma factor required for plastid RNA polymerase function) (7) and also either directly or indirectly modulate  $\text{SO}_4^{2-}$  transport activity through post-transcriptional processes.

expression through SNRK2.2 is eliminated (possibly through interaction with SAC1). These events would fully activate all of the genes associated with S deprivation, including those that trigger modification of the photosynthetic apparatus and modulation of the metabolism of the cell. Furthermore, SNRK2.2 also either directly or indirectly causes a loss of chloroplast sigma factor activity, which leads to a marked decrease in the level of chloroplast transcripts.

While there is considerable evidence to support the hypothetical scheme proposed above, the evidence is mostly genetic and there are still numerous unresolved questions. For example, while SNRK2.1 and SNRK2.2 are required for activation and repression of the S-deprivation

responsive genes, respectively, we have still not identified specific regulatory elements that bind to the DNA to activate and repress transcription. While it is likely that the sensory molecule in the system is SAC1, we still do not know whether it senses the S status of the system by interaction with  $\text{SO}_4^{2-}$  from the outside, reduced S metabolites from inside (e.g., via the TrkA-C domains) or both. The *sac1* and *snrk2.1* (*ars11*) mutants are defective in the induction of  $\text{SO}_4^{2-}$  transport activity (the levels of transcripts encoding the transporters remain low), demonstrating that they are needed for the first tier of regulation. It is not clear whether they are required for second tier regulation since second tier regulation will be aberrant



if the cells cannot synthesize the appropriate complement of proteins during the first tier. Furthermore, P and S metabolism in vascular plants (Wang et al. 2002), yeast (O'Connell and Baker 1992) and *Chlamydomonas* (Moseley et al. 2006, Moseley et al. 2009) appear to intersect, suggesting that dynamic regulatory networks integrate nutrient stress responses (and most likely responses to other conditions that limit cell growth). Establishing these links and the specific factors that facilitate the integration would be important for understanding the dynamic homeostasis of the cell as it experiences fluctuating environmental conditions.

## VI Phosphate Uptake and Assimilation

P is present in cells mostly as free or esterified phosphate ( $\text{PO}_4^{3-}$  throughout) and is integral to nucleic acids and phospholipids, can bond to proteins and modify their function, and is a key element of the energy currency (e.g., ATP) of the cell. This nutrient has been of major interest to both ecologists and farmers.

### A Phosphate in the Environment

Bioavailability of P often limits the growth of organisms in both the natural environment and agricultural settings. Therefore,  $\text{PO}_4^{3-}$  is included in fertilizers at high levels. However, this 'supplementary'  $\text{PO}_4^{3-}$  can be damaging to the environment since it can leach from soil, contaminating nearby lakes and rivers, leading to eutrophication and anoxia, which in turn can cause the death of aquatic animal life (Wetzel 1983). A more thorough understanding of  $\text{PO}_4^{3-}$  utilization by plants and microbes will be critical for developing future agricultural practices.

P is an abundant element in the earth's crust with many soils having a  $\text{PO}_4^{3-}$  content of between 0.5 and 1.5 mM. The various P compounds cycle in the environment (Fig. 3). However,  $\text{PO}_4^{3-}$  is frequently present as insoluble  $\text{Fe}^{3+}$ ,  $\text{Al}^{3+}$ , and  $\text{Ca}^{2+}$  salts that cannot be readily used by the biota. Furthermore, the pH and anion exchange characteristics of soils and the abundance of specific ligands associated with soil particles affect  $\text{PO}_4^{3-}$  bioavailability. A significant amount of  $\text{PO}_4^{3-}$

may be esterified to organic molecules, which would also make this nutrient difficult to access. Therefore, it is not uncommon to find plants and microbes in a state of P limitation (e.g., growth is limited by P availability). These organisms have evolved mechanisms that enable them to efficiently scavenge the  $\text{PO}_4^{3-}$  from their surroundings and to modify their metabolism to limit P utilization.

In a broad sense, organisms exhibit two classes of responses to limited P availability, the P-specific responses and the more global responses (Davies and Grossman 1998; Wykoff et al. 1998; Grossman and Takahashi 2001; Moseley and Grossman 2009). The former facilitate mobilization and acquisition from extracellular and intracellular P sources and include the synthesis of extracellular phosphatases with broad substrate specificity and high-affinity  $\text{PO}_4^{3-}$  transporters (Quisel et al. 1996; Shimogawara et al. 1999; Moseley et al. 2006). In addition, roots of numerous plants associate with mycorrhizal fungi, which enhance  $\text{PO}_4^{3-}$  mobilization from the soil and movement into the root system (Karandashov and Bucher 2005). Other plants, including those from the *Brassicaceae* or mustard family, do not form mycorrhizal associations but may acidify the soil and synthesize an array of  $\text{PO}_4^{3-}$  'accessing' enzymes (i.e., phytases and phosphatases), as well as systems for the efficient uptake of  $\text{PO}_4^{3-}$  (Poirier et al. 1991; Delhaize and Randall 1995; Gilbert et al. 1999; Li et al. 2002; Veljanovski et al. 2006). The global responses help sustain cell viability by coordinating the rate of cell growth and metabolism, as discussed for the S-deprivation responses, with reduced P availability.

*Chlamydomonas* exhibits a suite of responses upon exposure to P deprivation. These responses include the secretion of periplasmic phosphatases, which cleave  $\text{PO}_4^{3-}$  from organic  $\text{PO}_4^{3-}$  esters in the immediate environment, the mobilization of internal polyphosphate stores (possibly from excess nucleic acid in the cell), the activation of high-affinity  $\text{PO}_4^{3-}$  uptake systems and the substitution of glycolipids and sulfolipids for phospholipids. Furthermore, growth and division of the cell slows and then stops, metabolic processes may become diminished, and mechanisms may be established that allow cells to cope with the potential production of ROS. The ability to cope with ROS is especially critical for photosynthetic

organisms, where the potential to absorb light energy by pigment molecules such as chlorophyll under conditions in which that energy cannot be efficiently used for photochemistry and CO<sub>2</sub> fixation would lead to the accumulation of triplet-excited chlorophyll which could interact with oxygen to form singlet oxygen. Singlet oxygen could interact with membranes and proteins and severely disrupt cellular functions.

## B Phosphatases

Algae such as *Chlamydomonas* synthesize various phosphatases including acid phosphatases (Matagne and Loppes 1975; Matagne et al. 1976), neutral phosphatase and alkaline phosphatases, some of which are derepressed upon P starvation (Lien and Knutsen 1973; Loppes 1976b; Loppes et al. 1977; Loppes and Deltour 1981). Mutants with aberrant phosphatase activity have been isolated (Loppes and Matagne 1973; Matagne and Loppes 1975; Loppes 1976a; Loppes et al. 1977; Loppes and Deltour 1981) and the subcellular locations of some determined (Matagne et al. 1976; Patni et al. 1977; Quisel et al. 1996). Quisel et al. (1996) characterized extracellular phosphatases that accumulate upon exposure of *Chlamydomonas* to P limitation. The majority of the derepressible, extracellular phosphatase activity (~90% of total activity) has broad substrate specificity with an alkaline pH optimum, is Ca<sup>2+</sup>-dependent and inhibited by low Zn<sup>2+</sup> concentrations, and is associated with a ~190 kDa polypeptide. A second extracellular phosphatase (~10% of total) of 73 kDa that can slowly hydrolyze IMP and AMP is probably a neutral phosphatase (Dumont et al. 1990). There is also a third extracellular activity that is in low abundance (<5% of the total) (Quisel et al. 1996), that cannot use IMP or AMP as a substrate. The 190 kDa phosphatase of *Chlamydomonas* is the analog of the 160 kDa, extracellular phosphatase designated PHOX in *Volvox carteri* (Hallmann 1999), a multicellular alga closely related to *Chlamydomonas*.

P Starvation elicits elevated synthesis of intracellular and/or extracellular phosphatases in most organisms including the aquatic macrophyte *Spirodela oligorrhiza* (Nakazato et al. 1997), the intensely characterized plant *Arabidopsis* (Trull et al. 1997), and crop plants including radish, cabbage, wheat, rice, tomato, sugar beet, potato

and maize (Juma and Tabatabai 1988; Lee 1988; Goldstein et al. 1989; Duff et al. 1991; Sachay et al. 1991; Tadano et al. 1993). RNases may also increase during P deprivation, allowing for mobilization of PO<sub>4</sub><sup>3-</sup> from both extracellular and intracellular RNA pools. The death and decay of living matter make nucleic acids important sources of soil P, while the turnover of intracellular RNAs (e.g., rRNA) could be critical during conditions of both P limitation and cell senescence (Green 1994). Tomato plants synthesize at least four RNases in response to P starvation (Jost et al. 1991), of which three are probably vacuolar and function in recycling PO<sub>4</sub><sup>3-</sup> from cellular RNA. The fourth appears to be periplasmic (Nürnbergberger et al. 1990). The RNase genes of *Arabidopsis* have also been characterized (Taylor and Green 1991; Taylor et al. 1993; Bariola et al. 1994).

## C Phosphate Transport

PO<sub>4</sub><sup>3-</sup> transport into *Chlamydomonas* cells grown in replete and P-deficient medium has been characterized (Shimogawara et al. 1999). P starvation of this alga elicits a tenfold increase in the V<sub>max</sub> for Pi transport. Two distinct kinetic components associated with PO<sub>4</sub><sup>3-</sup> uptake were identified; the K<sub>m</sub> for one component (low affinity) is approximately 10 μM while that for the other (high affinity) is 0.1–0.3 μM. While the low affinity component dominates under nutrient-replete conditions, after 24 h of P starvation essentially all uptake occurs via the high affinity system. Recent work has led to the identification of many of the genes encoding PO<sub>4</sub><sup>3-</sup> transporters in *Chlamydomonas*.

P limitation can also elicit an elevation in the V<sub>max</sub> (not necessarily the K<sub>m</sub>) for PO<sub>4</sub><sup>3-</sup> uptake into plant roots (Bielecki 1973; Drew et al. 1984; Lefebvre and Clarkson 1984; Schjorring and Jensen 1984; McPharlin and Bielecki 1987; Jungk et al. 1990; Lefebvre et al. 1990; Bielecki and Laluchli 1992; Shimogawara and Usuda 1995). The uptake of PO<sub>4</sub><sup>3-</sup> by plants is metabolically-driven and could result in xylem sap PO<sub>4</sub><sup>3-</sup> reaching concentrations that are 400 times that of the soil solution. Many genes encoding plant PO<sub>4</sub><sup>3-</sup> transporters have been characterized (Muehhal and Raghothama 1999; Raghothama 2000a, b; Smith et al. 2000; Baek et al. 2001), although most plants exploit their associations

with mycorrhizal fungi to more efficiently access soil  $\text{PO}_4^{3-}$  (Alloush et al. 2000; Yao et al. 2001).

#### D Polyphosphate Synthesis and Mobilization

*Chlamydomonas* cells contain very little free  $\text{PO}_4^{3-}$ , with most residing in the chloroplast (Hebeler et al. 1992). P in the form of polyphosphate, a linear polymer of orthophosphate (Hebeler et al. 1992; Siderius et al. 1996), is a dominant form of stored P in *Chlamydomonas*. Polyphosphate polymers can contain hundreds of  $\text{PO}_4^{3-}$  residues. They may function in several cellular processes including buffering of the cytoplasmic pH, osmoregulation (Weiss et al. 1991; Leitao et al. 1995), and modulation of translation (McInerney et al. 2006). Most polyphosphate in *Chlamydomonas* are  $\text{Ca}^{2+}$ ,  $\text{Mg}^{2+}$  and  $\text{Zn}^{2+}$  salts that are housed in electron dense bodies present in the cytoplasm (Siderius et al. 1996). Werner et al. (2007) demonstrated that the amount of polyphosphate present in the cell wall is modulated during the cell cycle, with peak abundance during cytokinesis. P-replete growth favors the rapid incorporation of  $\text{PO}_4^{3-}$  into polyphosphates (Hebeler et al. 1992). However, when *Chlamydomonas* cells are starved for P, cellular polyphosphate levels rapidly decline to below detection, with a concomitant decline in the levels of ATP,  $\text{PO}_4^{3-}$  and sugar phosphates (Hebeler et al. 1992). Very little is known about the biochemistry of polyphosphate synthesis in *Chlamydomonas*, although the alga possesses an actin-related polyphosphate kinase that appears to be similar to one characterized in *Neurospora crassa* (Gomez-Garcia and Kornberg 2004). Furthermore, vacuolar transport chaperones (VTC) implicated in the maintenance of normal polyphosphate levels in *Saccharomyces cerevisiae* (Ogawa et al. 2000; Auesukaree et al. 2004) have been identified, based on gene sequences, in *Chlamydomonas*. In a preliminary study, a *Chlamydomonas* strain mutated for the VTC4 homologue was shown to be unable to accumulate normal amounts of polyphosphate (D. Gonzalez-Ballester and R. Gomez-Garcia, unpublished). Finally, Ruiz et al. (2001) have shown that polyphosphate bodies are associated with a proton-pumping pyrophosphatase and a  $\text{H}^+$ /ATPase, both of which may play important

roles in maintaining the acidic environment of the vacuole.

#### E Nucleic Acids

Significant re-allocation of  $\text{PO}_4^{3-}$  pools in both the cytoplasm and chloroplasts may be triggered by P-deprivation. Chloroplast transcripts have been shown to increase in abundance during P-starvation as a consequence of down-regulation of a chloroplast polynucleotide phosphorylase (PNPase). This enzyme, critical for the degradation of chloroplast RNA (cpRNA) (Kudla et al. 1996; Lisitsky et al. 1997; Nishimura et al. 2004), catalyzes polymerization of poly(A) tails onto cpRNA fragments generated by endonucleolytic cleavage, binds the newly synthesized poly(A) sequences and then degrades the entire RNA fragment. The poly(A) tails destabilize cpRNA transcripts (Slomovic et al. 2006), which contrasts with 3' polyadenylation stabilization of nuclear-synthesized transcripts. However, RNA degradation by PNPase is phosphorylytic rather than hydrolytic, and thus  $\text{PO}_4^{3-}$  is consumed in the reaction. Following P-starvation the abundance of the PNPase protein declines significantly, which results in decreased degradation of cpRNA (Yehudai-Resheff et al. 2007). The  $\text{PO}_4^{3-}$  required for the degradation process would be conserved for other essential processes in chloroplasts (e.g., ATP synthesis via cyclic electron transfer). Down-regulation of polynucleotide phosphate PNPase activity during P deprivation is at least partly controlled by the transcription factor PSR1. In a *psr1* mutant the PNPase protein level remains high during P-starvation, which results in cpRNA degradation that is even more pronounced than in P-replete, wild-type cells (Yehudai-Resheff et al. 2007).

In contrast to the maintenance of high levels of cpRNA during P-deprivation, the level of cpDNA declines (Yehudai-Resheff et al. 2007). Chloroplasts of nutrient-replete *Chlamydomonas* cells contain 80–100 copies of the 203 kb, circular cpDNA. However, it is likely that only a few copies of the genome suffice to maintain adequate chloroplast transcript levels when the cells are starved for P. The low cpDNA copy number occurs because of elevated degradation of the DNA and mobilization of nucleotides generated, or reduced DNA synthesis as the cells continue to

divide (there are three or four cell divisions after  $\text{PO}_4^{3-}$  is eliminated from the growth medium). In either case, the cells would be able to conserve P for processes essential to sustain viability during P deprivation.

### F Phospholipids

P-starvation of *Chlamydomonas* elicits changes in the lipid composition of the cell membranes (Riekhof et al. 2003). The membranes of *Chlamydomonas* contain the phospholipids phosphatidylglycerol (PG), phosphatidylethanolamine (PE) and phosphatidylinositol (PI) but lack phosphatidylcholine (PC) (Riekhof et al. 2003). P-starvation elicits a decline in the phospholipid composition of the membranes and a concurrent increase in levels of sulfoquinovosyldiacylglycerol (SQDG), and the novel sulfolipid, 2'-O-acyl-sulfoquinovosyldiacylglycerol (ASQD); the latter contains a higher ratio of unsaturated to saturated fatty acids than SQDG. Fractionation experiments with  $^{35}\text{S}$ -labeled lipids have demonstrated that there is a constant ASQD:SQDG ratio of 1:20 in P-replete and P-deprived cells, suggesting that the level of ASQD increases in concert with SQDG during P deprivation. The replacement of phospholipids with sulfolipids during P-deprivation preserves the anionic character of the membranes and allows for alternative uses of the  $\text{PO}_4^{3-}$ . The importance of these changes is reflected in the finding that the *sqd1* mutant of *Chlamydomonas* grows poorly under P-deficient conditions. Since SQD1 (UDP-sulfoquinovose synthase) represents the sole activity that can catalyze the synthesis of UDP-sulfoquinovose (from UDP-glucose and sulfite), a strain null for *SQD1* is completely devoid of sulfolipids. Sulfolipids are also important for optimal photosynthetic function in P-replete cells (Minoda et al. 2002; Riekhof et al. 2003), which is highlighted by the finding that the sulfolipid-deficient mutant *hf-2* has impaired photoautotrophic growth and photosystem II activity, even under nutrient-replete conditions (Sato et al. 1995a, b; Minoda et al. 2002).

### G Phosphorus Deficiency and Photosynthesis

Wykoff et al. (1998) demonstrated that *Chlamydomonas* undergoes a suite of responses

during P deprivation that lead to down-regulation of photosynthesis, which in turn reduces the potential for photodamage under conditions in which the absorbed light energy cannot be used for growth. As already mentioned, N and S starvation induce a similar set of changes in photosynthetic activity, but the changes are much more rapid in -S and -N medium than in -P medium reflecting the limited availability of internal S compared to P and the high cellular demand for N. The efficiency of light energy utilization is severely reduced after 4 days of P starvation, and the maximal  $\text{O}_2$ -evolution rate declines to ~25% of the initial rate. This decline has been attributed to an approximate 30% decrease in the amount of functional photosystem II and an increase in the proportion of photosystem II centers that are not competent for electron transfer from  $Q_A$  to  $Q_B$  ( $Q_B$  non-reducing centers). In addition, the P-starved cells exhibited non-photochemical quenching, which reduced the quantum efficiency of photosynthesis even at low light intensities. Activation of the xanthophyll cycle in P-starved *Chlamydomonas* leads to increased dissipation of absorbed light energy as heat, and the movement of light-harvesting antennae from photosystem II to photosystem I (state transition; cells transition from state 1 to state 2), which diverts excitation energy away from photosystem II (the photosystem I reaction center can act as a quencher). Furthermore, cyclic electron flow around photosystem I appears to be promoted during P-stress, presumably to maintain the  $\Delta\text{pH}$  necessary for non-photochemical quenching, and to enable production of ATP for the maintenance of cellular processes (Wykoff et al. 1998).

## VII Control of Phosphorus Starvation Responses

Understanding the biochemical responses of *Chlamydomonas* to P-deprivation has allowed us to develop specific screens for strains unable to acclimate to -P conditions.

### A Mutant Isolation

To identify *Chlamydomonas* regulatory proteins associated with P starvation responses, mutants were identified based on a screen for aberrant lev-



els of alkaline phosphatase activity or a greater tendency of the cells to bleach during P deprivation. One class of mutants exhibited decreased levels of alkaline phosphatase activity in response to P deprivation, a second class exhibited constitutive low level alkaline phosphatase activity (designated *psr*: phosphorus starvation response) (Shimogawara et al. 1999), while a third class did not readily bleach after the cells were placed in medium devoid of P (designated *lpb*; low phosphate bleaching) (Chang et al. 2005). The *psr1-1* and *psr1-2* mutants synthesize little extracellular phosphatase activity upon P starvation while the *psr2* mutant has low level, constitutive extracellular phosphatase activity in cultures maintained on complete medium (Shimogawara et al. 1999). The *lpb1-1* and *lpb1-2* mutants are significantly more susceptible to bleaching than wild-type cells following the imposition of P deprivation (Chang et al. 2005).

### 1 *PSR1* (Regulator in *Chlamydomonas reinhardtii* Associated with Phosphate Stress Response)

The *psr1* mutant was isolated as a strain unable to accumulate extracellular phosphatases in response to P starvation and could not access extracellular, esterified  $\text{PO}_4^{3-}$ , and therefore could not grow using glucose-1-phosphate as their sole source of P. This contrasts with the near normal growth rates of wild-type cells on medium in which glucose-1-phosphate was the sole P source. Isolation and characterization of the *PSR1* gene (Wykoff et al. 1999) revealed a deduced protein sequence of 762 amino acids with a MYB DNA binding domain (Lipsick 1996), suggesting that *PSR1* is a regulatory element that binds DNA and controls gene expression during P starvation. A similar Myb-containing protein in *Arabidopsis* that controls P-deprivation responses was designated *PHR1* (phosphate starvation response 1) (Rubio et al. 2001). The *Arabidopsis phr1* mutant cannot activate P starvation-responsive genes (Rubio et al. 2001; Bari et al. 2006) and, like *PSR1* in *Chlamydomonas*, the *PHR1* protein has been localized to the nucleus. Furthermore, it was shown to binds to an imperfect palindromic DNA sequence conserved in the promoters of P starvation-responsive genes (Rubio et al. 2001). Both *PSR1* and *PHR1* also have a coiled-coil domain thought to promote protein dimerization.

The coiled-coil domain of *PHR1* is required for sequence-specific binding to the DNA (Rubio et al. 2001). One difference between *PHR1* and *PSR1* is that the latter contains three glutamine-rich regions near the C terminus of the protein. These regions have been associated with positive regulatory activity of eukaryotic transcription factors (Pabo and Sauer 1992), and are potentially critical for *PSR1* function. While there are homologues of *PHR1* in other vascular plants, all of the plant proteins lack the glutamine-rich domains of the *Chlamydomonas* protein, which raises the possibility that a co-activator protein works in conjunction with *PHR1* to control plant P-deprivation-responsive gene expression.

Growth of *Chlamydomonas* cells for 4–8 h in medium lacking P elicited an increase in the *PSR1* transcript level, with a subsequent decline relative to the level observed in nutrient-replete cells after 24 h of starvation (Wykoff et al. 1999). Elevated *PSR1* transcript levels precede the induction of several P-starvation responsive genes, including those encoding high-affinity  $\text{PO}_4^{3-}$  transport systems and the extracellular phosphatase (Quisel et al. 1996; Shimogawara et al. 1999). *PSR1* protein levels increased by over tenfold after 1 day of P starvation (Wykoff et al. 1999) and most of the protein appears to be nuclear localized. Although *PSR1* does not have a recognizable nuclear-localization sequence, it does have a helix-loop-helix dimerization motif that has been associated with nuclear localization (Yoneda et al. 1999). It is possible that *PSR1* interacts with a nuclear-targeted protein that serves to carry the putative transcriptional activator into the nucleus. Since the same percentage of *PSR1* remains in the cytoplasm of starved and nonstarved cells (1–5% of total *PSR1*), translocation into the nucleus is not likely to be a key regulatory event in controlling P-starvation responses. This contrasts with the situation for yeast where the targeting of a transcription factor to the nucleus is critical for regulation during P deprivation (Komelli and O'Shea 1999).

There is still little known about regulatory processes that function both upstream and downstream of *PSR1*. It has been suggested that post-translational processes participate in the control of P-deprivation responses in plants (Miura et al. 2005), and sumoylation of *PHR1* was demonstrated in vitro. Furthermore, the *Arabidopsis siz1*

mutant, which is devoid of the E3 SUMO (small ubiquitin-like modifier) ligase designated sap interacting zinc finger protein, has a P-starvation root morphology, exhibits increased expression of some P-starvation responsive genes during P-replete growth, and is unable to induce the P-responsive genes during P-deprivation (Miura et al. 2005). Nevertheless, *in vivo* sumoylation of PHR1 has not been demonstrated, and it is possible that P starvation phenotypes in the *siz1* mutant are an indirect effect of the lesion. Furthermore, PSR1 lacks the consensus sumoylation sites present in PHR1 and these sites are not well conserved even among PHR1 plant homologues.

The extent of conservation between the *Chlamydomonas* and vascular plant P-deficiency-responsive signal transductions systems, beyond the similarities between PSR1 and PHR1, is not known. Recently it was demonstrated that PHR1 is required for induction of the *Arabidopsis* microRNA miR399 during P-starvation (Bari et al. 2006). The microRNA causes a reduction in the abundance of the *PHO2* transcript via a complementary interaction with sequences present in the 5' UTR of the *PHO2* transcript (Fujii et al. 2005; Chiou et al. 2006). *PHO2* encodes an E2 ubiquitin conjugase that represses expression of P starvation-inducible genes. Interestingly, *pho2* mutants accumulate high levels of leaf  $\text{PO}_4^{3-}$  and exhibit constitutively high expression of PHR1-dependent, P-starvation-induced genes (Delhaize and Randall 1995; Dong et al. 1998; Bari et al. 2006). While grafting experiments have demonstrated that *pho2* mutant roots are necessary and sufficient to cause increased shoot  $\text{PO}_4^{3-}$  accumulation (Bari et al. 2006), it is not known whether activation of PHR1-dependent gene expression in *pho2* mutants is caused by local P-deficiency in roots brought about by the inability of the plant to properly distribute  $\text{PO}_4^{3-}$ , or whether mutant plants maintain constitutive expression by not suppressing the activity of a positive regulatory element. Although no microRNAs with sequence similarity to miR399 have been identified on the *Chlamydomonas* genome, recent work has demonstrated that *Chlamydomonas* expresses a wide variety of miRNAs, with one potentially targeting the coding regions of genes for putative  $\text{PO}_4^{3-}$  transporters (Molnar et al. 2007; Zhao et al. 2007).

## 2 Low Phosphorus Bleaching Strains

The *lpb1* mutants (Chang et al. 2005) revealed another component of the P-starvation acclimation response that is distinct from responses controlled by PSR1. While P-deficiency-responsive gene expression occurs normally in P-starved *lpb1* mutant cells, the cultures rapidly bleach and die following the imposition of P-deprivation. The mutant phenotype was rescued by the *LPB1* gene, which encodes a polypeptide of 1,064 amino acids and possesses a domain with limited similarity to nucleotide-diphospho-sugar transferases, and a "P-loop" nucleotide-binding domain common to nucleotide triphosphate hydrolases. Homologues of LPB1 are present on the genomes of many plants and, according to programs that predict sub-cellular protein localization, LPB1 is likely to be in the chloroplast. The precise function of LPB1 has not been determined, although the presence of the nucleotide-diphospho-sugar transferase domain suggests a role in sugar or polysaccharide metabolism (Chang et al. 2005).

## B PSR1-Dependent Gene Expression

### 1 Phosphatases

Although sequence-specific DNA-binding has not been demonstrated for PSR1, potential target genes of this regulatory factor have been identified based on altered transcript abundance in P-deficient relative to P-replete cells, and loss of differential gene expression in *psr1* mutant strains (Moseley et al. 2006; Moseley and Grossman 2009). As expected, PSR1 is required for activation of phosphatase and other genes important for  $\text{PO}_4^{3-}$  assimilation during P-starvation. The *Volvox carteri* *PHOX* gene encodes an extracellular  $\text{Ca}^{2+}$ -dependent phosphatase (Hallmann 1999), which is similar, based on antibody reactions and amino-terminal sequencing, to the 190 kDa extracellular phosphatase that accumulates in *Chlamydomonas* when the cells are starved for P (Quisel et al. 1996). Both the transcript encoding the 190 kDa protein and the protein are not expressed in the *psr1* mutant during P deprivation (Moseley et al. 2006). A transcript encoding a putative phosphatase with some features similar to that of the purple acid phosphatases of *Arabidopsis* also shows a marked, PSR1-dependent

increase upon P-starvation (Moseley et al. 2006) and may also be secreted based on target P analysis. However, it is not known whether this gene encodes either of the minor inducible extracellular phosphatases previously characterized (Quisel et al. 1996).

## 2 Transporters

Analyses of *Chlamydomonas* genome sequences suggest that the development of high-affinity  $\text{PO}_4^{3-}$ -uptake that accompanies P deprivation involves changes in the activation state of a combination of genes encoding putative  $\text{PO}_4^{3-}$  transporters. Ten homologues of the yeast high-affinity  $\text{Na}^+/\text{PO}_4^{3-}$  symporter PHO89 are found on the *Chlamydomonas* genome, and the transcripts for at least four  $\text{PO}_4^{3-}$  transporters of the type B class (PTB) increase during P-starvation and are under PSR1 control (Kobayashi et al. 2003; Moseley et al. 2006). The expansion of this gene family is likely recent, as six PTB genes are found in two gene clusters (Moseley et al. 2006; Moseley and Grossman 2009). There are also four genes encoding Pi transporters of the type A class (PTA). These transporters are homologous to the yeast high-affinity  $\text{H}^+/\text{PO}_4^{3-}$  cotransporter encoded by PHO84. Of the PTA genes, only the PTA4 transcript increases during P deprivation, but the increase is not entirely dependent on PSR1. The levels of the PTA2 and PTA3 transcripts are little affected by P-deprivation, and the PTA3 and PTA4 mRNAs increase 25- and 5-fold, respectively, in cells starved for manganese. These results raise the possibility that PTA3 and PTA4 potentially function in  $\text{Mn}^{2+}/\text{PO}_4^{3-}$  co-transport (Fristedt et al. 1999; Jensen et al. 2003; Allen et al. 2007). Therefore, the elevated levels of PTA3 and PTA4 during P deprivation may reflect a reduced rate of uptake of the  $\text{Mn}^{2+}$  counter-ion. Interestingly, Mn-deficient cells have reduced intracellular P content, although they show no signs of P-deficiency-responsive gene expression (Allen et al. 2007).

The PTA2, PTA3 and PTA4 proteins are highly similar and tandemly arranged on the genome, suggesting a recent expansion of this gene family (Moseley et al. 2006). In contrast, there is a marked decline in the level of the PTA1 transcript following exposure of cells to P-starvation, and this decline does not occur in a *psr1* mutant

(Moseley et al. 2006). These characteristics suggest that PTA1 may be a low-affinity  $\text{PO}_4^{3-}$ -uptake system operating in P-replete cells. There is nothing currently known about the localization of any of the  $\text{PO}_4^{3-}$  transporters.

## 3 Other Genes

There are other genes linked to P metabolism that are differentially regulated during P starvation, many of which are under the control of PSR1. For example, the PSR1-regulated *CAX1* gene encodes a putative  $\text{H}^+/\text{Ca}^{2+}$  antiporter (Hanikenne et al. 2005); the protein product may be involved in regulating intracellular  $\text{Ca}^{2+}$  levels when  $\text{Ca}^{2+}$  is released from polyphosphate bodies (Moseley et al. 2006). The *VTC1* gene, also upregulated during P deprivation, encodes a homologue of yeast vacuolar transport chaperones that is associated with polyphosphate metabolism (Ogawa et al. 2000; Auesukaree et al. 2004). Furthermore, down-regulation of the *PNP* gene, which encodes the chloroplast PNPase, also appears to be under PSR1 control since no down-regulation is observed in *psr1* mutant strains (Yehudai-Resheff et al. 2007).

## 4 "Electron Valves"

PSR1 also appears to be critical for regulating a class of genes associated with 'electron valve' function. These genes encode activities that allow efficient dissipation of excitation energy from photosynthetic and respiratory electron transfer chains, which would prevent the potential production of harmful ROS under conditions that limit cellular growth and division. Transcripts from genes encoding both plastid and mitochondrial alternative oxidases increase in wild-type, P-deficient cells, but not in the *psr1* mutant. There is also an increase in transcripts encoding enzymes that function in starch synthesis and degradation, and fermentation metabolism (pyruvate-formate lyase and alcohol dehydrogenase); the oxygen level of cultures may decline significantly during P deprivation. Interestingly, some elevation in the level of the *HYDA2* transcript (but not that of *HYDA1*), which encodes a *Chlamydomonas* Fe-hydrogenase, is observed during P-starvation. Electrons used for the synthesis of  $\text{H}_2$  can

come from NADPH produced during fermentation (Atteia et al. 2006; Mus et al. 2007) or from reduced ferredoxin produced as a consequence of photosystem I activity (Benemann et al. 1973). Activation of genes encoding electron valve functions probably reflects the need to “bleed-off” electrons from photosynthetic electron transport when the rate of linear electron flow is limited by the rate at which reducing equivalents can be consumed; nutrient deprivation results in decreased CO<sub>2</sub> fixation and a decline in other anabolic activities. PSR1 may directly control genes encoding some electron valve polypeptides since their transcripts do not accumulate to high levels in the *psr1* mutant during P starvation, or alternatively, the *psr1* mutants may develop a different metabolic homeostasis as a consequence of its inability to properly acclimate to P-starvation conditions. It is clear that the physiological state of *psr1* mutant cells during P deprivation is different from that of wild-type cells as a number of additional “stress” genes are activated in the former.

### C Sequence of Regulatory Events

A speculative model depicting how PSR1 might regulate PO<sub>4</sub><sup>3-</sup> metabolism is presented in Fig. 6. Under nutrient-replete conditions, PSR1 is present, but at low levels and in an inactive state, which is controlled by external and/or internal sensors of the cellular P-status. For example, the *PTC1* gene product, which hasn't been characterized in *Chlamydomonas*, may serve as a sensor of external PO<sub>4</sub><sup>3-</sup> levels, similar to the homologous protein in yeast. Under conditions of high external PO<sub>4</sub><sup>3-</sup>, PTC1 would negatively regulate PSR1 activity. Alternatively, PSR1 might be sensitive to levels of intracellular PO<sub>4</sub><sup>3-</sup> or to the activity of the PO<sub>4</sub><sup>3-</sup> transporters. During P-starvation PSR1 is activated by a still undefined mechanism, and may temporally regulate transcription of specific genes as a consequence of binding to P starvation-activated promoters with different affinities. Early in the acclimation process the *PSR1* gene itself would be activated (although it not known if PSR1 is autoregulated), while the promoters of genes encoding components of the low affinity PO<sub>4</sub><sup>3-</sup>-uptake system would be repressed. As active PSR1 protein accumulates, it would bind the lower-affinity promoters (e.g., promoters of

genes encoding Na<sup>+</sup>/PO<sub>4</sub><sup>3-</sup> transporters, inducible phosphatases and electron valve functions). After 24 h of P deprivation, cell growth rates decline along with the level of the PSR1 transcript and transcripts from PO<sub>4</sub><sup>3-</sup> transporter and phosphatase genes. These results indicate that the cells may no longer need to synthesize additional phosphatases and transporters and other regulatory processes critical for the later stages of acclimation may begin to develop. For example, energy initially used for biosynthetic processes involved in scavenging external nutrient sources may be redirected towards metabolic systems that promote conservation and redistribution of internal nutrient sources, which would include a reduction in cpRNA as a consequence of degradation by PNPase and replacement of phospholipids with other anionic and neutral lipids. The various mechanisms that down-regulate photosynthesis also appear to become activated following ~24 h of P-starvation. Other models involving additional regulatory elements can also be envisioned. For example, as in the plant systems, miRNAs and proteolysis may play a role in regulating *PSR1*-dependent gene expression, although evidence for such pathways have yet to be discovered.

## VIII Conclusions

Genetic and molecular characteristics coupled with genome-wide analyses have made *Chlamydomonas* a strong photosynthetic eukaryote for elucidating many biological processes, including the ways in which photosynthetic organisms sense and respond to their nutrient environment. Comparative genomic analyses are providing clues concerning similarities and differences in the regulatory circuits associated with the acclimation of various organisms to nutrient deprivation, while genome-wide methods for examining gene expression are suggesting how organisms adjust their metabolism as nutrients become limiting. However, an understanding of nutrient limitation will require a broader analysis of the metabolic and physiological consequences of depleting an organism for a given nutrient, and the ways in which the different nutrient-starvation responses overlapping and integrate into the general metabolic processes of the cell.



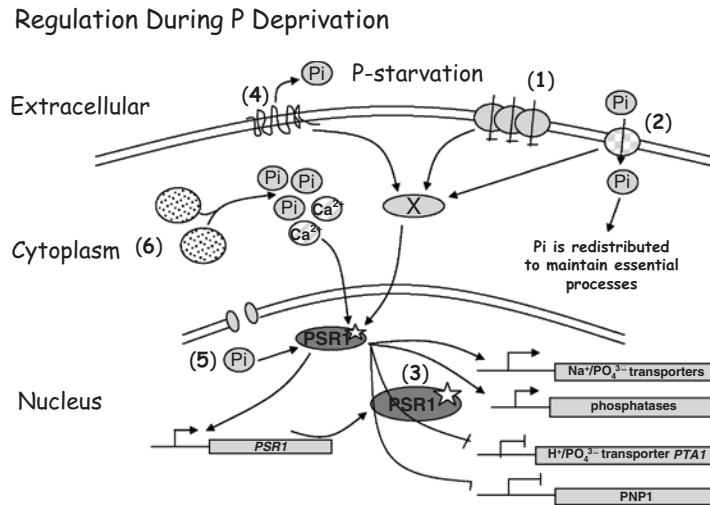

Fig. 6. Model depicting P-deprivation responses. When P becomes limiting in the growth medium, the  $\text{PO}_4^{3-}$  (Pi in figure)-uptake activity of the low affinity transporter (1) declines, but transport through the high-affinity system (2) is maintained. The declining  $\text{PO}_4^{3-}$  levels in the cell and/or transport of  $\text{PO}_4^{3-}$  exclusively through the high affinity system may provide a signal, designated X in this figure, that is transmitted to PSR1 in the nucleus and that enables PSR1 to activate transcription; the signal that alters PSR1 activity can even be just below the normal intracellular levels of  $\text{PO}_4^{3-}$ . Alteration of PSR1 during P deprivation is indicated with a star. PSR1 mRNA and protein abundance increases within 2 h of the transfer of cells to P-deficient medium (3), and this increased expression precedes activation of the  $\text{Na}^+/\text{PO}_4^{3-}$  transporter and the inducible phosphatase genes, and repression of PTA1 and PNP. Temporal difference in the expression of genes following the imposition of  $\text{PO}_4^{3-}$  deprivation may reflect the affinity of the individual promoters for PSR1. An alternative model is that the signal to activate PSR1 is transmitted when Pi dissociates from an external sensor (4); PSR1 might also respond to changes in the nuclear Pi concentration (5) as acclimation proceeds, cytoplasmic poly(P) is degraded, which buffers the cytoplasmic  $\text{PO}_4^{3-}$  concentration until the poly(P) stores are depleted (6); other mechanisms involving microRNA control and sumoylation may occur in vascular plants.

## Acknowledgements

Some of this work was supported by United States Department of Agriculture grant 2002-35301-12178 and National Science Foundation grants MCB 0235878 and MCB 0824469, all awarded to A.R.G. David Gonzalez Ballester was supported by the Ministerio de Educación y Ciencia (Spain).

## References

- Allen MD, Kropat J, Tottey S, Del Campo JA, Merchant SS (2007) Manganese deficiency in *Chlamydomonas* results in loss of Photosystem II and MnSOD function, sensitivity to peroxides, and secondary phosphorus and iron deficiency. *Plant Physiol* 143:263–277
- Allouh GAZ, Zeto SK, Clark RB (2000) Phosphorus source, organic matter and arbuscular mycorrhiza effects on growth and mineral acquisition of chickpea grown in acidic soil. *J Plant Nutr* 23:1351–1369
- Amarasinghe BHRR, deBruxelles GL, Braddon M, Onyeocha I, Forde BG, Udvardi MK (1998) Regulation of GmNRT2 expression and nitrate transport activity in roots of soybean (*Glycine max*). *Planta* 206:44–52
- Anantharaman V, Koonin EV, Aravind L (2001) Regulatory potential, phyletic distribution and evolution of ancient, intracellular small-molecule-binding domains. *J Mol Biol* 307:1271–1292
- Andreae MO, Crutzen PJ (1997) Atmospheric aerosols: biogeochemical sources and role in atmospheric chemistry. *Science* 276:1052–1058
- Andreae MO, Raemdonch H (1983) Dimethyl sulfide in the surface ocean and the marine atmosphere - a global view. *Science* 221:744–747

- Aoki H, Ida S (1994) Nucleotide sequence of a rice root ferredoxin-NADP<sup>+</sup> reductase cDNA and its induction by nitrate. *Biochem Biophys Res Commun* 1183:553–556
- Aparicio PJ, Quinones MA (1991) Blue light, a positive switch signal for nitrate and nitrite uptake by the green alga *Monoraphidium braunii*. *Plant Physiol* 95:374–378
- Aravind L, Koonin EV (2000) The STAS domain – a link between anion transporters and antisigma-factor antagonists. *Curr Biol* 10:R53–55
- Armbrust EV, Berges JA, Bowler C, Green BR, Martinez D, Putnam NH, Zhou S, Allen AE, Apt KE, Bechner M, Brzezinski MA, Chaal BK, Chiovitti A, Davis AK, Demarest MS, Detter JC, Glavina T, Goodstein D, Hadi MZ, Hellsten U, Hildebrand M, Jenkins BD, Jurka J, Kapitonov VV, Kroger N, Lau WW, Lane TW, Larimer FW, Lippmeier JC, Lucas S, Medina M, Montsant A, Obornik M, Parker MS, Palenik B, Pazour GJ, Richardson PM, Rynearson TA, Saito MA, Schwartz DC, Thamatrakoln K, Valentin K, Vardi A, Wilkerson FP, Rokhsar DS (2004) The genome of the diatom *Thalassiosira pseudonana*: ecology, evolution and metabolism. *Science* 306:79–86
- Arz HE, Gisselmann G, Schiffmann S, Schwenn JD (1994) A cDNA for adenylyl sulfate (APS)-kinase from *Arabidopsis thaliana*. *Biochim Biophys Acta* 1218:447–452
- Atteia A, van Lis R, Gelius-Dietrich G, Adrait A, Garin J, Joyard J, Rolland N, Martin W (2006) Pyruvate formate-lyase and a novel route of eukaryotic ATP synthesis in *Chlamydomonas* mitochondria. *J Biol Chem* 281:9909–9918
- Auesukaree C, Homma T, Tochio H, Shirakawa M, Kaneko Y, Harashima S (2004) Intracellular phosphate serves as a signal for the regulation of the PHO pathway in *Saccharomyces cerevisiae*. *J Biol Chem* 279:17289–17294
- Baek SH, Chung IM, Yun SJ (2001) Molecular cloning and characterization of a tobacco leaf cDNA encoding a phosphate transporter. *Mol Cells* 11:1–6
- Barabote RD, Tamang DG, Abeywardena SN, Fallah NS, Fu JY, Lio JK, Mirhosseini P, Pezeshk R, Podell S, Salampeyy ML, Thever MD, Saier MH Jr (2006) Extra domains in secondary transport carriers and channel proteins. *Biochim Biophys Acta* 1758:1557–1579
- Bari R, Datt Pant B, Stitt M, Scheible WR (2006) PHO2, microRNA399 and PHR1 define a phosphate-signaling pathway in plants. *Plant Physiol* 141:988–999
- Bariola PA, Howard CJ, Taylor CB, Verburg MT, Jaglan VD, Green PJ (1994) The *Arabidopsis* ribonuclease gene *RNS1* is tightly controlled in response to phosphate limitation. *Plant J* 6:673–685
- Benemann JR, Berenson JA, Kaplan NO, Kamen MD (1973) Hydrogen evolution by a chloroplast-ferredoxin-hydrogenase system. *Proc Natl Acad Sci USA* 70:2317–2320
- Bick JA, Aslund F, Chen Y, Leustek T (1998) Glutaredoxin function for the carboxyl terminal domain of the plant-type 5'-adenylylsulfate (APS) reductase. *Proc Natl Acad Sci USA* 95:8404–8409
- Bielecki RL (1973) Phosphate pools, phosphate transport, and phosphorus availability. *Annu Rev Plant Physiol Plant Mol Biol* 24:225–252
- Bielecki RL, Laluchli A (1992) Phosphate uptake, efflux and deficiency in the water fern, *Azolla*. *Plant Cell Environ* 15:665–673
- Bogdanova N, Hell R (1997) Cysteine synthesis in plants: protein-protein interactions of serine acetyltransferase from *Arabidopsis thaliana*. *Plant J* 11:251–262
- Bolchi A, Petrucco S, Tenca P, Foroni C, Ottonello S (1999) Coordinate modulation of maize sulfate permease and ATP sulfurylase mRNAs in response to variations in sulfur nutritional status: stereospecific down-regulation by L-cysteine. *Plant Mol Biol* 39:527–537
- Bork C, Schwenn JD, Hell R (1998) Isolation and characterization of a gene for assimilatory sulfite reductase from *Arabidopsis thaliana*. *Gene* 212:147–153
- Boudsocq M, Droillard MJ, Barbier-Brygoo H, Lauriere C (2007) Different phosphorylation mechanisms are involved in the activation of sucrose non-fermenting 1 related protein kinases 2 by osmotic stresses and abscisic acid. *Plant Mol Biol* 63:491–503
- Briggs WR, Huala E (1999) Blue-light photoreceptors in higher plants. *Annu Rev Cell Dev Biol* 15:33–62
- Bruhl A, Haverkamp T, Gisselmann G, Schwenn JD (1996) A cDNA clone from *Arabidopsis thaliana* encoding plastidic ferredoxin: sulfite reductase. *Biochim Biophys Acta* 1295:119–124
- Buchner P, Stuijver CE, Westerman S, Wirtz M, Hell R, Hawkesford MJ, De Kok LJ (2004) Regulation of sulfate uptake and expression of sulfate transporter genes in *Brassica oleracea* as affected by atmospheric H<sub>2</sub>S and pedospheric sulfate nutrition. *Plant Physiol* 136:3396–3408
- Campbell WH, Kinghorn JR (1990) Functional domains of assimilatory nitrate reductases and nitrite reductases. *Trends Biochem Sci* 15:315–319
- Chang CW, Moseley JL, Wykoff D, Grossman AR (2005) The LPB1 gene is important for acclimation of *Chlamydomonas reinhardtii* to phosphorus and sulfur deprivation. *Plant Physiol* 138:319–329
- Charlson RJ, Lovelock JE, Andreae MO, Warren SG (1987) Oceanic phytoplankton, atmospheric sulphur, cloud albedo and climate. *Nature* 326:655–661
- Chen HC, Melis A (2004) Localization and function of SulP, a nuclear-encoded chloroplast sulfate permease in *Chlamydomonas reinhardtii*. *Planta* 220:198–210
- Chen Q, Silflow CD (1996) Isolation and characterization of glutamine synthetase genes in *Chlamydomonas reinhardtii*. *Plant Physiol* 112:987–996
- Chen HC, Yokthongwattana K, Newton AJ, Melis A (2003) SulP, a nuclear gene encoding a putative chloroplast-targeted sulfate permease in *Chlamydomonas reinhardtii*. *Planta* 218:98–106
- Chen HC, Newton AJ, Melis A (2005) Role of SulP, a nuclear-encoded chloroplast sulfate permease, in sulfate

- transport and H2 evolution in *Chlamydomonas reinhardtii*. *Photosynth Res* 84:289–296
- Chernova MN, Jiang L, Shmukler BE, Schweinfest CW, Blanco P, Freedman SD, Stewart AK, Alper SL (2003) Acute regulation of the SLC26A3 congenital chloride diarrhoea anion exchanger (DRA) expressed in *Xenopus* oocytes. *J Physiol* 549:3–19
- Chiba Y, Ishikawa M, Kijima F, Tyson RH, Kim JH, Yamamoto A, Nambara E, Leustek T, Wallsgrove RM, Naito S (1999) Evidence for autoregulation of cystathionine  $\gamma$ -synthase mRNA stability in *Arabidopsis*. *Science* 286:1371–1374
- Chiou TJ, Aung K, Lin SI, Wu CC, Chiang SF, Ci Su (2006) Regulation of phosphate homeostasis by microRNA in *Arabidopsis*. *Plant Cell* 18:412–421
- Christie JM, Swartz TE, Bogomolni RA, Briggs WR (2002) Phototropin LOV domains exhibit distinct roles in regulating photoreceptor function. *Plant J* 32:205–219
- Cole DW, Johnson DW (1977) Atmospheric sulfate additions and cation leaching in a Douglas fir ecosystem. *Water Resources Res* 13:313–317
- Croft MT, Lawrence AD, Raux-Deery E, Warren MJ, Smith AG (2005) Algae acquire vitamin B12 through a symbiotic relationship with bacteria. *Nature* 438:90–93
- Croft MT, Warren MJ, Smith AG (2006) Riboswitch regulated gene expression in *Chlamydomonas reinhardtii* is involved in symbiotic interactions with bacteria. In: 12th International Conference on the Cell and Molecular Biology of *Chlamydomonas*, Portland, OR
- Crosson S, Rajagopal S, Moffat K (2003) The LOV domain family: photoresponsive signaling modules coupled to diverse output domains. *Biochemistry* 42:2–10
- Curien G, Job D, Douce R, Dumas R (1998) Allosteric activation of *Arabidopsis* threonine synthase by S-adenosylmethionine. *Biochemistry* 37:13212–13221
- David MB, Grigal DF, Ohmann LF, Gertner GZ (1988) Sulfur, carbon, and nitrogen relationships in forest soils across the northern Great Lakes States as affected by atmospheric deposition and vegetation. *Can J Forest Res* 18:1386–1391
- Davies J, Yildiz F, Grossman AR (1996) Sac1, a putative regulator that is critical for survival of *Chlamydomonas reinhardtii* during sulfur deprivation. *EMBO J* 15:2150–2159
- Davies JD, Grossman AR (1998) Responses to deficiencies in macronutrients. In: Rochaix JD, Goldschmidt-Clermont M, Merchant S (eds) *The Molecular Biology of Chlamydomonas*. Kluwer, Dordrecht, pp 613–635
- Davies JP, Yildiz F, Grossman AR (1994) Mutants of *Chlamydomonas reinhardtii* with aberrant responses to sulfur deprivation. *Plant Cell* 6:53–63
- Davies JP, Yildiz FH, Grossman AR (1999) Sac3, an Snf1-like serine/threonine kinase that positively and negatively regulates the responses of *Chlamydomonas* to sulfur limitation. *Plant Cell* 11:1179–1190
- de Hostos EL, Togasaki RK, Grossman AR (1988) Purification and biosynthesis of a derepressible periplasmic arylsulfatase from *Chlamydomonas reinhardtii*. *J Cell Biol* 106:29–37
- de Hostos EL, Schilling J, Grossman AR (1989) Structure and expression of the gene encoding the periplasmic arylsulfatase of *Chlamydomonas reinhardtii*. *Mol Gen Genet* 218:229–239
- Delhaize E, Randall PJ (1995) Characterization of a phosphate-accumulator mutant of *Arabidopsis thaliana*. *Plant Physiol* 107:207–213
- Dong B, Rengel Z, Delhaize E (1998) Uptake and translocation of phosphate by *pho2* mutant and wild-type seedlings of *Arabidopsis thaliana*. *Planta* 205:251–256
- Drew MC, Saker LR, Barber SA, Jenkins W (1984) Changes in the kinetics of phosphate and potassium absorption in nutrient-deficient barley roots measured by a solution-depletion technique. *Planta* 160:490–499
- Droux M, Ravel S, Douce R (1995) Methionine biosynthesis in higher plants – purification and characterization of cystathionine  $\beta$ -lyase from spinach chloroplasts. *Arch Biochem Biophys* 316:585–595
- Droux M, Ruffet ML, Douce R, Job D (1998) Interactions between serine acetyltransferase and O-acetylserine(thiol) lyase in higher plants. *Eur J Biochem* 255:235–245
- Duff SMG, Lefebvre DD, Plaxton WC (1991) Purification, characterization and sub-cellular localization of an acid phosphatase from *Brassica nigra* suspension cells - Comparison with phosphoenolpyruvate phosphatase. *Arch Biochem Biophys* 286:226–232
- Dumont F, Loppes R, Kremers P (1990) New polypeptides and in-vitro translatable mRNAs are produced by phosphate-starved cells of the unicellular alga *Chlamydomonas reinhardtii*. *Planta* 182:610–616
- Duncan L, Alper S, Losick R (1996) SpoIIAA governs the release of the cell-type specific transcription factor sigma F from its anti-sigma factor SpoIIAB. *J Mol Biol* 260:147–164
- Eberhard S, Jain M, Im CS, Pollock S, Shrager J, Lin Y, Peek AS, Grossman AR (2006) Generation of an oligonucleotide array for analysis of gene expression in *Chlamydomonas reinhardtii*. *Curr Genet* 49:106–124
- Ernilova EV, Zalutskaya ZM, Huang K, Beck CF (2004) Phototropin plays a crucial role in controlling changes in chemotaxis during the initial phase of the sexual life cycle in *Chlamydomonas*. *Planta* 219:420–427
- Everett LA, Green ED (1999) A family of mammalian anion transporters and their involvement in human genetic diseases. *Hum Mol Genet* 8:1883–1891
- Everett LA, Glaser B, Beck JC, Idol JR, Buchs A, Heyman M, Adawi F, Hazani E, Nassir E, Baxevanis AD, Sheffield VC, Green ED (1997) Pendred syndrome is caused by mutations in a putative sulphate transporter gene (PDS). *Nat Genet* 17:411–422
- Fernández E, Cardenas J (1989) Genetic and regulatory aspects of nitrate assimilation in algae. Oxford University Press, Oxford, pp 101–124
- Fernández E, Galvan A (2007) Inorganic nitrogen assimilation in *Chlamydomonas*. *J Exp Bot* 58:2279–2287

- Fernández E, Franco AR, Córdoba F, Cárdenas J (1986) Regulation of nitrate reductase levels in *Chlamydomonas reinhardtii*. *Cienc Biol (Coimbra)* 11:171–174
- Fernández E, Schnell R, Ranum LPW, Hussey SC, Silflow CD, Lefebvre PA (1989) Isolation and characterization of the nitrate reductase structural gene of *Chlamydomonas reinhardtii*. *Proc Natl Acad Sci USA* 86:6449–6453
- Fernández E, Galvan A, Quesada A (1998) Nitrogen assimilation and its regulation. In: Rochaix JD, Goldschmidt-Clermont M, Merchant SS (eds) *Molecular biology of Chlamydomonas: chloroplast and mitochondria*, pp 637–659
- Ferreira RMB, Teixeira ARN (1992) Sulfur starvation in *Lemna* leads to degradation of ribulose-bisphosphate carboxylase without plant death. *J Biol Chem* 267:7253–7257
- Filleur S, Daniel-Vedele F (1999) Expression analysis of a high-affinity nitrate transporter isolated from *Arabidopsis thaliana* by differential display. *Planta* 207:461–469
- Fischer WN, Kwart M, Hummel S, Frommer WB (1995) Substrate specificity and expression profile of amino acid transporters (AAPS) in *Arabidopsis*. *J Biol Chem* 270:16315–16320
- Fischer WN, Andre B, Rentsch D, Krollkiewicz S, Tegeder M, Breitzkreuz K, Frommer WB (1998) Amino acid transport in plants. *Trends Plant Sci* 3:188–195
- Forde BG (2000) Nitrate transporters in plants: structure, function and regulation. *Biochem Biophys Res Commun* 1465:219–235
- Forestier M, King P, Zhang L, Posewitz M, Schwarzer S, Happe T, Ghirardi ML, Seibert M (2003) Expression of two [Fe]-hydrogenases in *Chlamydomonas reinhardtii* under anaerobic conditions. *Eur J Biochem* 270:2750–2758
- Fouchard S, Hemschemeier A, Caruana A, Pruvost J, Legrand J, Happe T, Peltier G, Cournac L (2005) Autotrophic and mixotrophic hydrogen photoproduction in sulfur-deprived *chlamydomonas* cells. *Appl Environ Microbiol* 71:6199–6205
- Foyer CH, Fletcher JM (2001) Plant antioxidants: colour me healthy. *Biologist (London)* 48:115–120
- Foyer CH, Halliwell B (1976) The presence of glutathione and glutathione reductase in chloroplasts: a proposed role in ascorbic acid metabolism. *Planta* 133:21–25
- Franco AR, Cardenas J, Fernandez E (1987) Involvement of reversible inactivation in the regulation of nitrate reductase enzyme levels in *Chlamydomonas reinhardtii*. *Plant Physiol* 84:665–669
- Franco AR, Cardenas J, Fernandez E (1988) Regulation by ammonium of nitrate and nitrite assimilation in *Chlamydomonas reinhardtii*. *Biochem Biophys Res Commun* 951:98–103
- Fristedt U, van Der Rest M, Poolman B, Konings WN, Persson BL (1999) Studies of cytochrome c oxidase-driven H<sup>+</sup>-coupled phosphate transport catalyzed by the *Saccharomyces cerevisiae* Pho84 permease in coreconstituted vesicles. *Biochemistry* 38:16010–16015
- Fujii H, Chiou TJ, Lin SI, Aung K, Zhu JK (2005) A miRNA involved in phosphate-starvation response in *Arabidopsis*. *Curr Biol* 15:2038–2043
- Fujii H, Verslues PE, Zhu JK (2007) Identification of two protein kinases required for abscisic acid regulation of seed germination, root growth and gene expression in *Arabidopsis*. *Plant Cell* 19:485–494
- Galván A, Marquez AJ, Vega JM (1984) Purification and molecular properties of ferredoxin-glutamate synthase from *Chlamydomonas reinhardtii*. *Planta* 162:180–187
- Galván A, Quesada A, Fernandez E (1996) Nitrate and nitrite are transported by different specific transport systems and by a bispecific transporter in *Chlamydomonas reinhardtii*. *J Biol Chem* 271:2088–2092
- Ghirardi ML, Posewitz MC, Maness PC, Dubini A, Yu J, Seibert M (2007) Hydrogenases and hydrogen photoproduction in oxygenic photosynthetic organisms. *Annu Rev Plant Biol* 58:71–91
- Gilbert GA, Knight JD, Vance CP, Allen DL (1999) Acid phosphatase activity in phosphorous-deficient white lupin roots. *Plant Cell Environ* 22:801–810
- Gojon A, Dapoigny L, Lejay L, Tillard P, Ruyff TW (1998) Effects of genetic modification of nitrate reductase expression on (no3)-N-15 uptake and reduction in *Nicotiana* plants. *Plant Cell Environ* 21:43–53
- Goldstein AH, Baertlein DA, Danon A (1989) Phosphate starvation stress as an experimental system for molecular analysis. *Plant Mol Biol Rep* 7:7–16
- Gomez-Garcia MR, Kornberg A (2004) Formation of an actin-like filament concurrent with the enzymatic synthesis of inorganic polyphosphate. *Proc Natl Acad Sci USA* 101:15876–15880
- Gonzalez-Ballester D, Grossman AR (2009) Sulfur: from acquisition to assimilation. In: Stern D, Harris EH, Witman GB (eds) *The Chlamydomonas Sourcebook*. Academic Press, Amsterdam, pp 159–187
- Gonzalez-Ballester D, Camargo A, Fernandez E (2004) Ammonium transporter genes in *Chlamydomonas*: the nitrate-specific regulatory gene Nit2 is involved in Amt1; 1 expression. *Plant Mol Biol* 56:863–878
- Gonzalez-Ballester D, de Montaigu A, Higuera JJ, Galvan A, Fernandez E (2005) Functional genomics of the regulation of the nitrate assimilation pathway in *Chlamydomonas*. *Plant Physiol* 137:522–533
- Gonzalez-Ballester D, Pollock P, Pootakham W, Grossman AR (2008) The central role of a SNRK2 kinase in sulfur deprivation responses. *Plant Physiol* 147:216–227
- Goodenough U, Lin H, Lee JH (2007) Sex determination in *Chlamydomonas*. *Semin Cell Dev Biol* 18:350–361
- Gotor C, Cejudo FJ, Baroso C (1997) Tissue-specific expression of AtCys-3A gene encoding the cytosolic isoform of O-acetylserine(thiol)lyase in *Arabidopsis*. *Plant J* 11:347–352
- Green PJ (1994) The ribonucleases of higher plants. *Annu Rev Plant Physiol Plant Mol Biol* 45:421–445



- Grill E, Löffler S, Winnacker EL, Zenk MH (1989) Phytochelatins, the heavy-metal-binding peptides of plants, are synthesized from glutathione by a specific  $\gamma$ -glutamylcysteine dipeptidyl transpeptidase (phytochelatin synthetase). *Proc Natl Acad Sci USA* 86:6838–6842
- Grossman A, Takahashi H (2001) Macronutrient utilization by photosynthetic eukaryotes and the fabric of interactions. *Annu Rev Plant Physiol Plant Mol Biol* 52: 163–210
- Grossman AR, Croft M, Gladyshev VN, Merchant SS, Posewitz MC, Prochnik S, Spalding MH (2007) Novel metabolism in *Chlamydomonas* through the lens of genomics. *Curr Opin Plant Biol* 10:190–198
- Guerrero MG, Vega JM, Losada M (1981) The assimilatory nitrate reducing system and its regulation. *Annu Rev Plant Physiol* 32:169–204
- Guiz C, Hirel B, Shedlofsky G, Gadal P (1979) Occurrence and influence of light on the relative proportions of 2 glutamine synthetases in rice leaves. *Plant Sci* 15: 271–277
- Gupta AS, Alscher RG, McCune DF (1990) Ozone exposure, glutathione levels and photosynthesis in hybrid poplar. In: H Rennenberg, C Brunold, LJ Dekoli, I Stulen (eds) Sulfur nutrition and sulfur assimilation in higher plants. SPB Academic Publications, the Hague, the Netherlands, pp 195–197
- Gutierrez-Marcos J, Roberts M, Campbell E, Wray J (1996) Three members of a novel small gene-family from *Arabidopsis thaliana* able to complement functionally an *Escherichia coli* mutant defective in PAPS reductase activity encode proteins with a thioredoxin-like domain and “APS reductase” activity. *Proc Natl Acad Sci USA* 93:13377–13382
- Habicht KS, Gade M, Thamdrup B, Berg P, Canfield DE (2002) Calibration of sulfate levels in the archaean oceans. *Science* 298:2372–2374
- Hallmann A (1999) Enzymes in the extracellular matrix of *Volvox*: an inducible, calcium-dependent phosphatase with a modular composition. *J Biol Chem* 274: 1691–1697
- Hanikenne M, Kramer U, Demoulin V, Baurain D (2005) A comparative inventory of metal transporters in the green alga *Chlamydomonas reinhardtii* and the red alga *Cyanidioschizon merolae*. *Plant Physiol* 137:428–446
- Hartmann T, Honicke P, Wirtz M, Hell R, Rennenberg H, Kopriva S (2004) Regulation of sulphate assimilation by glutathione in poplars (*Populus tremula* x *P. alba*) of wild type and overexpressing gamma-glutamylcysteine synthetase in the cytosol. *J Exp Bot* 55:837–845
- Hatzfeld Y, Lee S, Lee M, Leustek T, Saito K (2000) Functional characterization of a gene encoding a fourth ATP sulfurylase isoform from *Arabidopsis thaliana*. *Gene* 248:51–58
- Hebeler M, Hentrich S, Mayer A, Leibfritz D, Grimme LH (1992) Phosphate regulation and compartmentation in *Chlamydomonas reinhardtii* studied by in vivo <sup>31</sup>P-NMR. In: Murat N (ed) *Research in Photosynthesis*. Kluwer, the Netherlands, pp 717–720
- Herschbach C, Rennenberg H (1994) Influence of glutathione (GSH) on net uptake of sulfate and sulfate transport in tobacco plants. *J Exp Bot* 45:1069–1076
- Hesse H, Lipke J, Altmann T, Hofgen R (1999) Molecular cloning and expression analysis of mitochondrial and plastidic isoforms of cysteine synthase [O-acetylserine(thio) lyase] from *Arabidopsis thaliana*. *Amino Acids* 16: 113–131
- Hirner A, Ladwig F, Stransky H, Okumoto S, Keinath M, Harms A, Frommer WB, Koch W (2006) *Arabidopsis* LHT1 is a high-affinity transporter for cellular amino acid uptake in both root epidermis and leaf mesophyll. *Plant Cell* 18:1931–1946
- Ho MS, Carniol K, Losick R (2003) Evidence in support of a docking model for the release of the transcription factor sigma F from the antisigma factor SpoIIAB in *Bacillus subtilis*. *J Biol Chem* 278:20898–20905
- Howarth JR, Fourcroy P, Davidian JC, Smith FW, Hawkesford MJ (2003) Cloning of two contrasting high-affinity sulfate transporters from tomato induced by low sulfate and infection by the vascular pathogen *Verticillium dahliae*. *Planta* 218:58–64
- Huang K, Beck CF (2003) Phototropin is the blue-light receptor that controls multiple steps in the sexual life cycle of the green alga *Chlamydomonas reinhardtii*. *Proc Natl Acad Sci USA* 100:6269–6274
- Im CS, Eberhard S, Huang K, Beck C, Grossman AR (2006) Phototropin involvement in expression of genes encoding chlorophyll and carotenoid biosynthesis enzymes and LHC apoproteins in *Chlamydomonas reinhardtii*. *Plant J* 48:1–16
- Irihimovitch V, Stern DB (2006) The sulfur acclimation SAC3 kinase is required for chloroplast transcriptional repression under sulfur limitation in *Chlamydomonas reinhardtii*. *Proc Natl Acad Sci USA* 103:7911–7916
- Jensen LT, Ajua-Alemanji M, Culotta VC (2003) The *Saccharomyces cerevisiae* high affinity phosphate transporter encoded by PHO84 also functions in manganese homeostasis. *J Biol Chem* 278:42036–42040
- Jin T, Huppe HC, Turpin DH (1998) In vitro reconstitution of electron transport from glucose-6-phosphate and NADPH to nitrite. *Plant Physiol* 117:303–309
- Johnson DW, Turner J, Kelly JM (1982) The effects of acid rain on forest nutrient status. *Water Res* 18:449–461
- Jones KM, Kobayashi H, Davies BW, Taga ME, Walker GC (2007) How rhizobial symbionts invade plants: the *Sinorhizobium-Medicago* model. *Nat Rev Microbiol* 5:619–633
- Jost W, Bak H, Blund K, Terpstra P, Beintema JJ (1991) Amino acid sequence of an extracellular, phosphate-starvation-induced ribonuclease from cultured tomato (*Lycopersicon esculentum*) cells. *Eur J Biochem* 198:1–6
- Juma NG, Tabatabai MA (1988) Comparison of kinetic and thermodynamic parameters of phosphomonoesterases

- of soils and corn and soybean roots. *Soil Biol Biochem* 20:533–540
- Jungk A, Asher CJ, Edwards DG, Meyers D (1990) Influence of phosphate status on phosphate uptake kinetics of maize (*Zea mays*) and soybean (*Glycine max*). *Plant Soil* 124:175–182
- Kagawa T, Wada M (2002) Blue light-induced chloroplast relocation. *Plant Cell Physiol* 43:367–371
- Kagawa T, Sakai T, Suetsugu N, Oikawa K, Ishiguro S, Kato T, Tabata S, Okada K, Wada M (2001) *Arabidopsis* NPL1: a phototropin homolog controlling the chloroplast high-light avoidance response. *Science* 291:2138–2141
- Kamiya A (1988) Blue light-induced in vivo absorbance changes and in vitro activation of nitrate reductase in nitrate-starved *Chlorella* mutant. *Plant Cell Physiol* 29:489–496
- Karandashov V, Bucher M (2005) Symbiotic phosphate transport in arbuscular mycorrhizas. *Trends Plant Sci* 10:22–29
- Kataoka T, Hayashi N, Yamaya T, Takahashi H (2004a) Root-to-shoot transport of sulfate in *Arabidopsis* - Evidence for the role of SULTR3;5 as a component of low-affinity sulfate transport system in the root vasculature. *Plant Physiol* 136:4198–4204
- Kataoka T, Watanabe-Takahashi A, Hayashi N, Ohnishi M, Mimura T, Buchner P, Hawkesford MJ, Yamaya T, Takahashi H (2004b) Vacuolar sulfate transporters are essential determinants controlling internal distribution of sulfate in *Arabidopsis*. *Plant Cell* 16:2693–2704
- Kawashima CG, Berkowitz O, Hell R, Noji M, Saito K (2005) Characterization and expression analysis of a serine acetyltransferase gene family involved in a key step of the sulfur assimilation pathway in *Arabidopsis*. *Plant Physiol* 137:220–230
- Kieber DJ, Jiao J, Kiene RP, Bates TS (1996) Impact of dimethylsulfide photochemistry on methyl sulfur cycling in the equatorial Pacific Ocean. *J Geophys Res* 101:3715–3722
- Kim H, Hirai MY, Hayashi H, Chino M, Naito S, Fujiwara T (1999) Role of O-acetyl-L-serine in the coordinated regulation of the expression of a soybean seed storage-protein gene by sulfur and nitrogen nutrition. *Planta* 209:282–289
- Kinoshita T, Emi T, Tominaga M, Sakamoto K, Shigenaga A, Doi M, Shimazaki K (2003) Blue-light- and phosphorylation-dependent binding of a 14–3–3 protein to phototropins in stomatal guard cells of broad bean. *Plant Physiol* 133:1453–1463
- Kirk DL, Kirk MM (1978) Carrier-mediated uptake of arginine and urea by *Chlamydomonas reinhardtii*. *Plant Physiol* 61:556–560
- Klonus D, Höfgen R, Willmitzer L, Riesmeier J (1994) Isolation and characterization of two cDNA clones encoding ATP-sulfurylases from potato by complementation of a yeast mutant. *Plant J* 6:105–112
- Ko SB, Shcheynikov N, Choi JY, Luo X, Ishibashi K, Thomas PJ, Kim JY, Kim KH, Lee MG, Naruse S, Muallem S (2002) A molecular mechanism for aberrant CFTR-dependent HCO<sub>3</sub><sup>-</sup> transport in cystic fibrosis. *EMBO J* 21:5662–5672
- Kobayashi I, Fujiwara S, Shimogawara K, Kaise T, Usuda H, Tsuzuki M (2003) Insertional mutagenesis in a homologue of a Pi transporter gene confers arsenate resistance on *Chlamydomonas*. *Plant Cell Physiol* 44:597–606
- Koh S, Wiles AM, Sharp JS, Naider FR, Becker JM, Stacey G (2002) An oligopeptide transporter gene family in *Arabidopsis*. *Plant Physiol* 128:21–29
- Komelli A, O'Shea EK (1999) Roles of phosphorylation sites in regulatin activity of the transcription factor Pho4. *Science* 284:977–980
- Kopriva S (2006) Regulation of sulfate assimilation in *Arabidopsis* and beyond. *Ann Bot (Lond)* 97:479–495
- Koprivova A, Suter M, den Camp RO, Brunhold C, Kopriva S (2000) Regulation of sulfate assimilation by nitrogen in *Arabidopsis*. *Plant Physiol* 122:737–746
- Kraegeloh A, Amendt B, Kunte HJ (2005) Potassium transport in a halophilic member of the bacteria domain: identification and characterization of the K<sup>+</sup> uptake systems TrkH and TrkI from *Halomonas elongata* DSM 2581T. *J Bacteriol* 187:1036–1043
- Kredich N (1992) The molecular basis for positive regulation of cys promoters in *Salmonella typhimurium* and *Escherichia coli*. *Mol Microbiol* 6:2747–2753
- Kudla J, Hayes R, Gruijssem W (1996) Polyadenylation accelerates degradation of chloroplast mRNA. *EMBO J* 15:7137–7146
- Kugita M, Kaneko A, Yamamoto Y, Takeya Y, Matsumoto T, Yoshinaga K (2003) The complete nucleotide sequence of the hornwort (*Anthoceros formosae*) chloroplast genome: insight into the earliest land plants. *Nucleic Acids Res* 31:716–721
- Kunert KJ, Foyer C (1993) Thiol/disulfide exchange in plants. In: de Kik LJ, Stulen I, Rennenberg H, Brunold C, Rauser WE (eds) Sulfur nutrition and sulfur assimilation in higher plants. SPB Academic, the Hague, the Netherlands, pp 139–151
- Kustu S, Inwood W (2006) Biological gas channels for NH<sub>3</sub> and CO<sub>2</sub>: evidence that Rh (Rhesus) proteins are CO<sub>2</sub> channels. *Transfus Clin Biol* 13:103–110
- Lam HM, Coschigano KT, Oliveira IC, Melo-Oliveira R, Coruzzi GM (1996) The molecular genetics of nitrogen assimilation into amino acids in higher plants. *Annu Rev Plant Physiol* 47:569–593
- Lappartient AG, Touraine B (1996) Demand-driven control of root ATP sulfurylase activity and SO<sub>4</sub><sup>-</sup> uptake in intact canola: the role of phloem-translocated glutathione. *Plant Physiol* 111:147–157
- Lappartient AG, Vidmar JJ, Leustek T, Glass ADM, Touraine B (1999) Inter-organ signaling in plants: regulation of ATP sulfurylase and sulfate transporter genes expres-

- sion in roots mediated by phloem-translocated compound. *Plant J* 18:89–95
- Law MY, Charles SA, Halliwell B (1983) Glutathione and ascorbic acid in spinach (*Spinacia oleracea*) chloroplasts: the effect of hydrogen peroxide and of paraquat. *Biochem J* 210:899–903
- Lea PJ, Robinson SA, Stewart GR (1990) The enzymology and metabolism of glutamine, glutamate, and asparagine. In: Mifflin BJ, Lea PJ (eds) *The biochemistry of plants: a comprehensive treatise*. Academic Press, New York, pp 121–160
- Lee RB (1988) Phosphatase influx and extracellular phosphatase activity in barley roots and rose cells. *New Phytol* 109:141–148
- Lee S, Leustek T (1998) APS kinase from *Arabidopsis thaliana*: genomic organization, expression and kinetic analysis of the recombinant enzyme. *Biochem Biophys Res Commun* 247:171–175
- Lee S, Leustek T (1999) The effect of cadmium on sulfate assimilation enzymes in *Brassica juncea*. *Plant Sci* 141:201–207
- Lefebvre DD, Clarkson DT (1984) Characterization of orthophosphate absorption by pea root protoplasts. *J Exp Bot* 35:1265–1276
- Lefebvre DD, Duff SMG, Fife CA, Julien-Inalsingh C, Plaxton WC (1990) Response to phosphate deprivation in *Brassica nigra* suspension cells: enhancement of intracellular, cell surface and secreted phosphatase activities compared to increases in Pi-absorption rate. *Plant Physiol* 93:504–511
- Leitao JM, Lorenz B, Bachinski N, Wilhelm C, Muller WEG, Schroder HC (1995) Osmotic-stress-induced synthesis and degradation of inorganic polyphosphates in the alga *Phaeodactylum tricorutum*. *Mar Ecol Prog Ser* 121:279–288
- Lejay L, Tillard P, Lepetit M, Olive FD, Filleur S, Daniel-Vedele F, Gojon A (1999) Molecular and functional regulation of two NO<sub>3</sub><sup>-</sup> uptake systems by N- and C-status of *Arabidopsis* plants. *Plant J* 18:509–519
- Lemieux C, Otis C, Turmel M (2000) Ancestral chloroplast genome in *Mesostigma viride* reveals an early branch of green plant evolution. *Nature* 403:649–652
- Leustek T, Saito K (1999) Sulfate transport and assimilation in plants. *Plant Physiol* 120:637–643
- Leustek T, Murillo M, Cervantes M (1994) Cloning of a cDNA encoding ATP sulfurylase from *Arabidopsis thaliana* by functional expression in *Saccharomyces cerevisiae*. *Plant Physiol* 105:897–902
- Li D, Zhu H, Liu K, Liu X, Leggewie G, Udvardi M, Wang D (2002) Purple acid phosphatases of *Arabidopsis thaliana* - Comparative analysis and differential regulation by phosphate deprivation. *J Biol Chem* 277:27772–27781
- Lien T, Knutsen G (1973) Phosphate as a control factor in cell division of *Chlamydomonas reinhardtii*, studies in synchronous culture. *Exptl Cell Res* 78:79–88
- Lin H, Goodenough UW (2007) Gametogenesis in the *Chlamydomonas reinhardtii* minus mating type is controlled by two genes, MID and MTD1. *Genetics* 176:913–925
- Lipsick JS (1996) One billion year of Myb. *Oncogene* 13:223–235
- Lisitsky I, Kotler A, Schuster G (1997) The mechanism of preferential degradation of polyadenylated RNA in the chloroplast – The exoribonuclease 100RNP/polynucleotide phosphorylase displays high binding affinity for poly(A) sequence. *J Biol Chem* 272:17648–17653
- Liu KH, Tsay YF (2003) Switching between the two action modes of the dual-affinity nitrate transporter CHL1 by phosphorylation. *EMBO J* 22:1005–1013
- Logan HM, Cathala N, Grignon C, Davidian JC (1996) Cloning of a cDNA encoded by a member of the *Arabidopsis thaliana* ATP sulfurylase multigene family: Expression studies in yeast and in relation to plant sulfur nutrition. *J Biol Chem* 271:12227–12233
- Lomans BP, van der Drift C, Pol A, Op den Camp HJ (2002) Microbial cycling of volatile organic sulfur compounds. *Cell Mol Life Sci* 59:575–588
- Loppes R (1976a) Genes involved in the regulation of the neutral phosphatase in *Chlamydomonas reinhardtii*. *Mol Gen Genet* 148:315–321
- Loppes R (1976b) Release of enzymes by normal and wall-free cells of *Chlamydomonas*. *J Bacteriol* 128:114–116
- Loppes R, Deltour R (1981) A pleiotropic mutant of *Chlamydomonas reinhardtii* showing cell wall abnormalities and altered phosphatase activities. *Plant Sci Lett* 21:193–197
- Loppes R, Matagne RF (1973) Acid phosphatase mutants in *Chlamydomonas*: isolation and characterization by biochemical, electrophoretic and genetic analysis. *Genetics* 75:593–604
- Loppes R, Braipson J, Matagne RF, Sassen A, Ledoux L (1977) Regulation of the neutral phosphatase in *Chlamydomonas reinhardtii*: an immunogenetic study of wild-type and mutant strains. *Biochem Genet* 15:1147–1157
- Lovelock JE (1972) Gaia as seen through the atmosphere. *Atmos Environ* 6:579–580
- Lunn JE, Droux M, Martin J, Douce R (1990) Localization of ATP sulfurylase and O-acetyl(thiol)lyase in spinach leaves. *Plant Physiol* 94:1345–1352
- MacDonald NW, Burton AJ, Jurgensen MF, McLaughlin JW, Mroz GD (1991) Variation in forest soil properties along a Great Lakes air pollution gradient. *Soil Sci Soc Am J* 55:1709–1715
- Mahler RJ, Maples RL (1986) Responses of wheat to sulfur fertilization. *Commun Soil Sci Plant Anal* 17:975–988
- Mahler RJ, Maples RL (1987) Effect of sulfur additions on soil and the nutrition of wheat. *Commun Soil Sci Plant Anal* 18:653–673

- Mann AF, Fentem PA, Stewart GR (1979) Identification of 2 forms of glutamine synthetase in barley (*Hordeum vulgare*). *Biochem Biophys Res Commun* 88:515–521
- Mariscal V, Moulin P, Orsel M, Miller AJ, Fernandez E, Galvan A (2006) Differential regulation of the *Chlamydomonas* *Nar1* gene family by carbon and nitrogen. *Protist* 157:421–433
- Marquez AG, Galvan F, Vega JM (1984) Purification and characterization of the NADH-glutamate synthase from *Chlamydomonas reinhardtii*. *Plant Sci* 34:305–314
- Marrs KA (1996) The functions and regulation of glutathione S-transferases in plants. *Annu Rev Plant Physiol* 47:127–158
- Marschner H (1995) Mineral nutrition of higher plants, 2nd edn. Academic Press, London
- Maruyama-Nakashita A, Nakamura Y, Tohge T, Saito K, Takahashi H (2006) *Arabidopsis* SLIM1 is a central transcriptional regulator of plant sulfur response and metabolism. *Plant Cell* 18:3235–3251
- Matagne RF, Loppes R (1975) Isolation and study of mutants lacking a derepressible phosphatase in *Chlamydomonas reinhardtii*. *Genetics* 80:239–250
- Matagne RF, Loppes R, Deltour R (1976) Phosphatases of *Chlamydomonas reinhardtii*: Biochemical and cytochemical approach with specific mutants. *J Bacteriol* 126:937–950
- Matsumura T, Sakakibara H, Nakano R, Kimata Y, Sugiyama T, Hase T (1997) A nitrate-inducible ferredoxin in maize roots – genomic organization and differential expression of two non-photosynthetic ferredoxin isoproteins. *Plant Physiol* 114:653–660
- May MJ, Leaver CJ (1994) *Arabidopsis thaliana*  $\Psi$ -glutamylcysteine synthase is structurally unrelated to mammalian, yeast and *Escherichia coli* homologs. *Proc Natl Acad Sci USA* 91:10059–10063
- McInerney P, Mizutani T, Shiba T (2006) Inorganic polyphosphate interacts with ribosomes and promotes translation fidelity *in vitro* and *in vivo*. *Mol Microbiol* 60:438–447
- McPharlin IR, Bielecki RL (1987) Phosphate uptake by *Spirodela* and *Lemna* during early phosphorus deficiency. *Aust J Plant Physiol* 14:561–572
- Meister A (1994) Glutathione-ascorbic acid antioxidant system in animals. *J Biol Chem* 269:9397–9400
- Meister A, Anderson ME (1983) Glutathione. *Annu Rev Biochem* 52:711–760
- Melis A (2007) Photosynthetic  $H_2$  metabolism in *Chlamydomonas reinhardtii* (unicellular green algae). *Planta* 226:1075–1086
- Melis A, Chen HC (2005) Chloroplast sulfate transport in green algae—genes, proteins and effects. *Photosynth Res* 86:299–307
- Merchan F, van den Ende H, Fernandez E, Beck CF (2001) Low-expression genes induced by nitrogen starvation and subsequent sexual differentiation in *Chlamydomonas reinhardtii*, isolated by the differential display technique. *Planta* 213:309–317
- Merchant SS, Prochnik SE, Vallon O, Harris EH, Karpowicz SJ, Witman GB, Terry A, Salamov A, Fritz-Laylin LK, Marechal-Drouard L, Marshall WF, Qu LH, Nelson DR, Sanderfoot AA, Spalding MH, Kapitonov VV, Ren Q, Ferris P, Lindquist E, Shapiro H, Lucas SM, Grimwood J, Schmutz J, Cardol P, Cerutti H, Chanfreau G, Chen CL, Cognat V, Croft MT, Dent R, Dutcher S, Fernandez E, Fukuzawa H, Gonzalez-Ballester D, Gonzalez-Halphen D, Hallmann A, Hanikenne M, Hippler M, Inwood W, Jabbari K, Kalanon M, Kuras R, Lefebvre PA, Lemaire SD, Lobanov AV, Lohr M, Manuell A, Meier I, Mets L, Mittag M, Mittelmeier T, Moroney JV, Moseley J, Napoli C, Nedelcu AM, Niyogi K, Novoselov SV, Paulsen IT, Pazour G, Purton S, Ral JP, Riano-Pachon DM, Riekhof W, Rymarquis L, Schroda M, Stern D, Umen J, Willows R, Wilson N, Zimmer SL, Allmer J, Balk J, Bisova K, Chen CJ, Elias M, Gendler K, Hauser C, Lamb MR, Ledford H, Long JC, Minagawa J, Page MD, Pan J, Pootakham W, Roje S, Rose A, Stahlberg E, Terauchi AM, Yang P, Ball S, Bowler C, Dieckmann CL, Gladyshev VN, Green P, Jorgensen R, Mayfield S, Mueller-Roeber B, Rajamani S, Sayre RT, Brokstein P, Dubchak I, Goodstein D, Hornick L, Huang YW, Jhaveri J, Luo Y, Martinez D, Ngau WC, Otilar B, Poliakov A, Porter A, Szajkowski L, Werner G, Zhou K, Grigoriev IV, Rokhsar DS, Grossman AR (2007) The *Chlamydomonas* genome reveals the evolution of key animal and plant functions. *Science* 318:245–250
- Miller AJ, Smith SJ (1996) Nitrate transport and compartmentation in cereal roots. *J Exp Bot* 47:843–854
- Miller AJ, Fan X, Orsel M, Smith SJ, Wells DM (2007) Nitrate transport and signalling. *J Exp Bot* 58:2297–2306
- Minoda A, Sato N, Nozaki H, Okada K, Takahashi H, Sonoike K, Tsuzuki M (2002) Role of sulfoquinovosyl diacylglycerol for the maintenance of photosystem II in *Chlamydomonas reinhardtii*. *Eur J Biochem* 269:2353–2358
- Miura K, Rus A, Sharkhuu A, Yokoi S, Karthikeyan AS, Raghothama KG, Baek D, Koo YD, Jin JB, Bressan RA, Yun D-J, Hasegawa PM (2005) The *Arabidopsis* SUMO E3 ligase SIZ1 controls phosphate deficiency responses. *Proc Natl Acad Sci USA* 102:7760–7765
- Molnar A, Schwach F, Studholme DJ, Thuenemann EC, Baulcombe DC (2007) miRNAs control gene expression in the single-cell alga *Chlamydomonas reinhardtii*. *Nature* 447:1126–1129
- Moseley JL, Grossman AR (2009) Phosphorus limitation from the physiological to the genomic. In: EH Harris, D Stern, GB Witman (eds) *The Chlamydomonas Sourcebook*. Academic Press, Amsterdam, pp 189–215
- Moseley JL, Chang CW, Grossman AR (2006) Genome-based approaches to understanding phosphorus deprivation responses and PSR1 control in *Chlamydomonas reinhardtii*. *Eukaryot Cell* 5:26–44
- Moseley J, Gonzalez-Ballester D, Pootakham W, Bailey S, Grossman AR (2009) Genetic interactions between regulators of *Chlamydomonas* phosphorus and sulfur deprivation responses. *Genetics* 181:889–905



- Muchhal US, Raghothama KG (1999) Transcriptional regulation of plant phosphate transporters. *Proc Natl Acad Sci USA* 96:5868–5872
- Murillo M, Leustek T (1995) Adenosine-5'-triphosphate sulfurylase from *Arabidopsis thaliana* and *Escherichia coli* are functionally equivalent but structurally and kinetically divergent: nucleotide sequence of two adenosine-5'-triphosphate sulfurylase cDNAs from *Arabidopsis thaliana* and analysis of a recombinant enzyme. *Arch Biochem Biophys* 323:195–204
- Mus F, Dubini A, Seibert M, Posewitz MC, Grossman AR (2007) Anaerobic acclimation in *Chlamydomonas reinhardtii*: anoxic gene expression, hydrogenase induction and metabolic pathways. *J Biol Chem* 282:25475–25486
- Muttucumar N, Halford NG, Elmore JS, Dodson AT, Parry M, Shewry PR, Mottram DS (2006) Formation of high levels of acrylamide during the processing of flour derived from sulfate-deprived wheat. *J Agric Food Chem* 54:8951–8955
- Naito S, Yokota-Hirai M, Chino M, Komeda Y (1994) Expression of soybean (*Glycine max* L. Merr.) seed storage protein gene in transgenic *Arabidopsis thaliana* and its response to nutritional stress and to abscisic acid mutations. *Plant Physiol* 104:497–503
- Najafi SM, Harris DA, Yudkin MD (1996) The SpoIIAA protein of *Bacillus subtilis* has GTP-binding properties. *J Bacteriol* 178:6632–6634
- Nakazato H, Okamoto T, Ishikawa M, Okuyama H (1997) Purification and characterization of phosphate inducibly synthesized in *Spirodela oligorrhiza* grown under phosphate deficient conditions. *Plant Physiol* 35:437–446
- Nanatani K, Fujiki T, Kanou K, Takeda-Shitaka M, Umeyama H, Ye L, Wang X, Nakajima T, Uchida T, Maloney PC, Abe K (2007) Topology of AspT, the aspartate: alanine antiporter of *Tetragenococcus halophilus*, determined by site-directed fluorescence labeling. *J Bacteriol* 189:7089–7097
- Navarro MT, Prieto R, Fernandez E, Galvan A (1996) Constitutive expression of nitrate reductase changes the regulation of nitrate and nitrite transporters in *Chlamydomonas reinhardtii*. *Plant J* 9:819–827
- Nishimura Y, Kikis EA, Zimmer SL, Komine Y, Stern DB (2004) Antisense transcript and RNA processing alterations suppress instability of polyadenylated mRNA in *Chlamydomonas* chloroplasts. *Plant Cell* 16:2849–2869
- Nocito FF, Lancilli C, Crema B, Fourcroy P, Davidian JC, Sacchi GA (2006) Heavy metal stress and sulfate uptake in maize roots. *Plant Physiol* 141:1138–1148
- Noctor G, Arisi AC, Jouanin L, Kunert KJ, Rennenberg H, Foyer C (1998) Glutathione: biosynthesis, metabolism and relationship to stress tolerance explored in transgenic plants. *J Exp Bot* 49:623–647
- Noji M, Saito K (2002) Molecular and biochemical analysis of serine acetyltransferase and cysteine synthase towards sulfur metabolic engineering in plants. *Amino Acids* 22:231–243
- Noji M, Inoue K, Kimura N, Gouda A, Saito K (1998) Isoform-dependent differences in feedback regulation and subcellular localization of serine acetyltransferase involved in cysteine biosynthesis from *Arabidopsis thaliana*. *J Biol Chem* 273:32739–32745
- Noji M, Takagi Y, Kimura N, Inoue K, Saito M, Horikoshi M, Saito F, Takahashi H, Saito K (2001) Serine acetyltransferase involved in cysteine biosynthesis from spinach: molecular cloning, characterization and expression analysis of cDNA encoding a plastidic isoform. *Plant Cell Physiol* 42:627–634
- Nürnberg T, Abel S, Jost W, Glund K (1990) Induction of an extracellular ribonuclease in cultured tomato cells upon phosphate starvation. *Plant Physiol* 92:970–976
- O'Connell KF, Baker RE (1992) Possible cross-regulation of phosphate and sulfate metabolism in *Saccharomyces cerevisiae*. *Genetics* 132:63–73
- Ogawa N, DeRisi J, Brown PO (2000) New components of a system for phosphate accumulation and polyphosphate metabolism in *Saccharomyces cerevisiae* revealed by genomic expression analysis. *Mol Biol Cell* 11:4309–4321
- Ohta N, Matsuzaki M, Misumi O, Miyagishima SY, Nozaki H, Tanaka K, Shin IT, Kohara Y, Kuroiwa T (2003) Complete sequence and analysis of the plastid genome of the unicellular red alga *Cyanidioschyzon merolae*. *DNA Res* 10:67–77
- Ohyama K, Fukuzawa H, Kohchi T, Sano T, Sano S, Shirai H, Umesono K, Shiki Y, Takeuchi M, Chang Z, Aota S, Inokuchi H, Ozeki H (1988) Structure and organization of *Marchantia polymorpha* chloroplast genome. I. Cloning and gene identification. *J Mol Biol* 203:281–298
- Okumoto S, Koch W, Tegeder M, Fischer WN, Biehl A, Leister D, Stierhof YD, Frommer WB (2004) Root phloem-specific expression of the plasma membrane amino acid proton co-transporter AAP3. *J Exp Bot* 55:2155–2168
- Ozcan S, Dover J, Rosenwald AG, Wolf S, Johnston M (1996) Two glucose transporters in *Saccharomyces cerevisiae* are glucose sensors that generate a signal for induction of gene expression. *Proc Natl Acad Sci USA* 93:12428–12432
- Ozcan S, Dover J, Johnston M (1998) Glucose sensing and signaling by two glucose receptors in the yeast *Saccharomyces cerevisiae*. *EMBO J* 17:2566–2573
- Pabo CO, Sauer RT (1992) Transcription factors: structural families and principles of DNA recognition. *Annu Rev Biochem* 61:1053–1095
- Pasquale SM, Goodenough UW (1987) Cyclic AMP functions as a primary sexual signal in gametes of *Chlamydomonas reinhardtii*. *J Cell Biol* 105:2279–2292
- Patni NJ, Dhawale SW, Aaronson S (1977) Extracellular phosphatases of *Chlamydomonas reinhardtii* and their regulation. *J Bacteriol* 130:205–211
- Peltier G, Schmidt GW (1991) Chlororespiration: an adaptation to nitrogen deficiency in *Chlamydomonas reinhardtii*. *Proc Natl Acad Sci USA* 88:4791–4795

- Petrucchio S, Bolchi A, Foroni C, Percudani R, Rossi GL, Ottonello S (1996) A maize gene encoding as NADPH binding enzyme highly homologous to isoflavone reductase is activated in response to sulfur starvation. *Plant Cell Environ* 8:69–80
- Peuke AD, Jeschke WD, Hartung W (1998) Foliar application of nitrate or ammonium as sole nitrogen supply in *Ricinus communis*. II. The flows of cations, chloride and abscisic acid. *New Phytol* 140:625–636
- Piedras P, Pineda M, Muñoz J, Cardenas J (1992) Purification and characterization of an L-amino-acid oxidase from *Chlamydomonas reinhardtii*. *Planta* 188:13–18
- Pineda M, Cardenas J (1996) Transport and assimilation of purines in *Chlamydomonas reinhardtii*. *Scientia Marina* 60:195–201
- Plumley FG, Schmidt GW (1989) Nitrogen-dependent regulation of photosynthetic gene expression. *Proc Natl Acad Sci USA* 86:2678–2682
- Poirier Y, Thoma S, Somerville C, Schiefelbein J (1991) A mutant in *Arabidopsis* deficient in xylem loading of phosphate. *Plant Physiol* 97:1087–1093
- Pollock SV, Pootakham W, Shibagaki N, Moseley JL, Grossman AR (2005) Insights into the acclimation of *Chlamydomonas reinhardtii* to sulfur deprivation. *Photosynth Res* 86:475–489
- Pootakham W, Grossman AR (2009) The sulfate transporters of *Chlamydomonas reinhardtii* and their regulation. In Preparation
- Prieto R, Dubus A, Galvan A, Fernandez E (1996) Isolation and characterization of two new negative regulatory mutants for nitrate assimilation in *Chlamydomonas reinhardtii* obtained by insertional mutagenesis. *Mol Gen Genet* 251:461–471
- Prior A, Uhrig JF, Heins L, Wiesmann A, Lilliq CH, Stolz C, Soll J, Schwenn JD (1999) Structural and kinetic properties of adenylylsulfate reductase from *Catheranthus roseus* cell cultures. *Biochem Biophys Res Commun* 1430:25–38
- Quesada A, Fernández E (1994) Expression of nitrate assimilation related genes in *Chlamydomonas reinhardtii*. *Plant Mol Biol* 24:185–194
- Quesada A, Galván A, Schnell R, Lefebvre PA, Fernández E (1993) Five nitrate assimilation-related loci are clustered in *Chlamydomonas reinhardtii*. *Mol Gen Genet* 240:387–394
- Quesada A, Galván A, Fernández E (1994) Identification of nitrate transporter genes in *Chlamydomonas reinhardtii*. *Plant J* 5:407–419
- Quesada A, Krapp A, Trueman LJ, Daniel-Vedele F, Fernández E, Forde BG, Caboche M (1997) PCR-identification of a *Nicotiana plumbaginifolia* cDNA homologous to the high-affinity nitrate transporters of the crnA family. *Plant Mol Biol* 34:265–274
- Quesada A, Gomez I, Fernández E (1998) Clustering of the nitrite reductase gene and a light-regulated gene with nitrate assimilation loci in *Chlamydomonas reinhardtii*. *Planta* 206:259–265
- Quiñones MA, Aparicio PJ (1990) Flavin type action spectrum of nitrate utilization by *Monoraphidium braunii*. *Photobiochem Photobiophys* 51:689–692
- Quiñones MA, Galván A, Fernández E, Aparicio PJ (1999) Blue-light requirement for the biosynthesis of an NO<sub>2</sub><sup>-</sup> transport system in the *Chlamydomonas reinhardtii* nitrate transport mutant S10. *Plant Cell Environ* 22:1169–1175
- Quisel J, Wykoff D, Grossman AR (1996) Biochemical characterization of the extracellular phosphatases produced by phosphorus-deprived *Chlamydomonas reinhardtii*. *Plant Physiol* 111:839–848
- Raghothama KG (2000a) Phosphate transport and signaling. *Curr Opin Plant Biol* 3:182–187
- Raghothama KG (2000b) Phosphorus acquisition; plant in the driver's seat. *Trends Plant Sci* 5:412–413
- Rausser WE (1987) Changes in glutathione content of maize seedlings exposed to cadmium. *Plant Sci* 51:171–175
- Ravel S, Droux M, Douce R (1995a) Methionine biosynthesis in higher plants. Purification and characterization of cystathionine  $\gamma$ -synthase from spinach chloroplasts. *Arch Biochem Biophys* 316:572–584
- Ravel S, Ruffet ML, Douce R (1995b) Cloning of an *Arabidopsis thaliana* cDNA encoding cystathionine  $\beta$ -lyase by functional complementation in *Escherichia coli*. *Plant Mol Biol* 29:875–882
- Ravel S, Job D, Douce R (1996) Purification and properties of cystathionine  $\beta$ -lyase from *Arabidopsis thaliana* overexpressed in *Escherichia coli*. *Biochem J* 320:383–392
- Ravel S, Gakiere B, Job D, Douce R (1998a) Cystathionine  $\gamma$ -synthase from *Arabidopsis thaliana*: purification and biochemical characterization of the recombinant enzyme overexpressed in *Escherichia coli*. *Biochem J* 331:639–648
- Ravel S, Gakiere B, Job D, Douce R (1998b) The specific features of methionine biosynthesis and metabolism in plants. *Proc Natl Acad Sci USA* 95:7805–7812
- Ravina CG, Barroso C, Vega JM, Gotor C (1999) Cysteine biosynthesis in *Chlamydomonas reinhardtii* – molecular cloning and regulation of O-acetylserine(thiol)lyase. *Eur J Biochem* 264:848–853
- Ravina CG, Chang CI, Tsakraklides GP, McDermott JP, Vega JM, Leustek T, Gotor C, Davies J (2002) Transcriptional and post-transcriptional control of cysteine biosynthesis in *Chlamydomonas reinhardtii*. *Plant Physiol* 130:2076–2084
- Rawlins MR, Leaver CJ, May MJ (1995) Characterization of an *Arabidopsis thaliana* cDNA encoding glutathione synthetase. *FEBS Lett* 376:81–86
- Redinbaugh MG, Campbell WH (1998) Nitrate regulation of the oxidative pentose phosphate pathway in maize (*Zea mays* L.) root platis: induction of 6-phosphogluconate dehydrogenase activity, protein and transcript levels. *Plant Sci* 134:129–140

- Remans T, Nacry P, Pervent M, Filleur S, Diatloff E, Mounier E, Tillard P, Forde BG, Gojon A (2006) The *Arabidopsis* NRT1.1 transporter participates in the signaling pathway triggering root colonization of nitrate-rich patches. *Proc Natl Acad Sci USA* 103:19206–19211
- Rennerberg H (1982) Glutathione metabolism and possible biological role in higher plants. *Phytochem* 21:2771–2781
- Rentsch D, Boorer KJ, Frommer WB (1998) Structure and function of plasma membrane amino acid, oligopeptides and sucrose transporters from higher plants. *J Memb Biol* 162:177–190
- Rexach J, Montero B, Fernandez E, Galvan A (1999) Differential regulation of the high affinity nitrite transport systems III and IV in *Chlamydomonas reinhardtii*. *Plant Cell Environ* 12:1441–1453
- Rexach J, Fernandez E, Galvan A (2000) The *Chlamydomonas reinhardtii* *Nar1* gene encodes a chloroplast membrane protein involved in nitrite transport. *Plant Cell Environ* 12:1441–1453
- Riekhof WR, Ruckle ME, Lydic TA, Sears BB, Benning C (2003) The sulfolipids 2'-O-acyl-sulfoquinovosyldiacylglycerol and sulfoquinovosyldiacylglycerol are absent from a *Chlamydomonas reinhardtii* mutant deleted in SQD1. *Plant Physiol* 133:864–874
- Ritchie SW, Redinbaugh MG, Shiraishi N, Vrba JM, Campbell WH (1994) Identification of a maize root transcript expressed in the primary response to nitrate: characterization of a cDNA with homology to ferredoxin-NADP oxidoreductase. *Plant Mol Biol* 26:679–690
- Rodriguez C, Sanz P, Gancedo C (2003) New mutations of *Saccharomyces cerevisiae* that partially relieve both glucose and galactose repression activate the protein kinase Snf1. *FEMS Yeast Res* 3:77–84
- Romer S, Dharlingue A, Camara B, Schantz R, Kuntz M (1992) Cysteine synthase from *Capsicum annuum* chromoplasts: characterization and cDNA cloning of an up-regulated enzyme during fruit development. *J Biol Chem* 267:17966–17970
- Rost B, Schneider R, Sander C (1997) Protein fold recognition by prediction-based threading. *J Mol Biol* 270:471–480
- Rotte C, Leustek T (2000) Differential subcellular localization and expression of ATP sulfurylase and 5'-adenylylsulfate reductase during ontogenesis of *Arabidopsis* leaves indicates that cytosolic and plastid forms of ATP sulfurylase may have specialized functions. *Plant Physiol* 124:715–724
- Rouached H, Berthomieu P, El Kassis E, Cathala N, Catherine V, Labesse G, Davidian JC, Fourcroy P (2005) Structural and functional analysis of the C-terminal STAS (sulfate transporter and anti-sigma antagonist) domain of the *Arabidopsis thaliana* sulfate transporter SULTR1.2. *J Biol Chem* 280:15976–15983
- Rubio V, Linhares F, Solano R, Martin AC, Iglesias J, Leyva A, Paz-Ares J (2001) A conserved MYB transcription factor involved in phosphate starvation signaling both in vascular plants and in unicellular algae. *Genes Dev* 15:2122–2133
- Ruffet M-L, Lebrun M, Droux M, Douce R (1995) Sub-cellular localization of serine acetyltransferase from *Pisum sativum* and characterization of an *Arabidopsis thaliana* putative cytosolic isoform. *Eur J Biochem* 227:500–509
- Ruiz FA, Marchesini N, Seufferheld M, Govindjee, Docampo R (2001) The polyphosphate bodies of *Chlamydomonas reinhardtii* possess a proton-pumping pyrophosphatase and are similar to acidocalcisomes. *J Biol Chem* 276:46196–46203
- Sachay JE, Wallace RL, Johns MA (1991) Phosphate stress response in hydroponically grown maize. *Plant Soil* 132:85–90
- Saito K (2000) Regulation of sulfate transport and synthesis of sulfur-containing amino acids. *Curr Opin Plant Biol* 3:188–195
- Saito K, Miura N, Yamazaki M, Hirano H, Murakoshi I (1992) Molecular cloning and bacterial expression of cDNA encoding a plant cysteine synthase. *Proc Natl Acad Sci USA* 89:8078–8082
- Saito K, Tatsuguchi K, Takagi Y, Murakoshi I (1994) Isolation and characterization of cDNA that encodes a putative mitochondrion-localizing isoform of cysteine synthase [O-acetylserine(thiol)lyase] from *Spinacia oleracea*. *J Biol Chem* 269:28187–28192
- Saito K, Yokoyama H, Noji M, Murakoshi I (1995) Molecular cloning and characterization of a plant serine acetyltransferase playing a regulatory role in cysteine biosynthesis from watermelon. *J Biol Chem* 270:16321–16326
- Saito K, Inoue K, Fukushima R, Noji M (1997) Genomic structure and expression analyses of serine acetyltransferase gene in *Citrullus vulgaris* (watermelon). *Gene* 189:57–63
- Sato N, Sonoike K, Tsuzuki M, Kawaguchi A (1995a) Impaired Photosystem II in a mutant of *Chlamydomonas reinhardtii* defective in sulfoquinovosyl diacylglycerol. *Eur J Biochem* 234:16–23
- Sato N, Tsuzuki M, Matsuda Y, Ehara T, Osafune T, Kawaguchi A (1995b) Isolation and characterization of mutants affected in lipid metabolism of *Chlamydomonas reinhardtii*. *Eur J Biochem* 230:987–993
- Savard F, Richard C, Guertin M (1996) The *Chlamydomonas reinhardtii* LI818 gene represents a distant relative of the cabII genes that is regulated during the cell cycle and in response to illumination. *Plant Mol Biol* 32:461–473
- Scheible WR, Lauerer M, Schulze ED, Caboche M, Stitt M (1997) Accumulation of nitrate in the shoot acts as a signal to regulate shoot-root allocation in tobacco. *Plant J* 11:671–691
- Scheller HV, Huang B, Hatch E, Goldsbrough PB (1987) Phytochelatin synthesis and glutathione levels in response to heavy metals in tomato cells. *Plant Physiol* 85:1031–1035

- Schjorring JK, Jensen P (1984) Phosphorus nutrition of barley, buckwheat and rape seedlings. II. Influx and efflux of phosphorus by intact roots of different P status. *Physiol Plantarum* 61:584–590
- Schnell RA, Lefebvre PA (1993) Isolation of the *Chlamydomonas* regulatory gene *NIT2* by transposon tagging. *Genetics* 134:737–747
- Schreiner O, Lien T, Knutsen G (1975) The capacity for arylsulfatase synthesis in synchronous and synchronized cultures of *Chlamydomonas reinhardtii*. *Biochim Biophys Acta* 384:180–193
- Schultze M, Quiclet-Sire B, Kondorosi E, Virelizer H, Glushka JN, Endre G, Gero SD, Kondorosi A (1992) *Rhizobium meliloti* produces a family of sulfated lipooligosaccharides exhibiting different degrees of plant host specificity. *Proc Natl Acad Sci USA* 89:192–196
- Schürmann P, Brunold C (1980) Formation of cysteine from adenosine 5'-phosphosulfate (APS) in extracts from spinach chloroplasts. *Z. Pflanzenphysiol* 100:257–268
- Sechley KA, Yamaya T, Oaks A (1992) Compartmentation of nitrogen assimilation in higher plants. *Int Rev Cytol* 134:85–163
- Setya A, Murillo M, Leustek T (1996) Sulfate reduction in higher plants: molecular evidence for a novel 5'-adenylsulfate reductase. *Proc Natl Acad Sci USA* 93:13383–13388
- Shibagaki N, Grossman AR (2004) Probing the function of STAS domains of the *Arabidopsis* sulfate transporters. *J Biol Chem* 279:30791–30799
- Shibagaki N, Grossman AR (2006) The role of the STAS domain in the function and biogenesis of a sulfate transporter as probed by random mutagenesis. *J Biol Chem* 281:22964–22973
- Shibagaki N, Rose A, McDermott JP, Fujiwara T, Hayashi H, Yoneyama T, Davies JP (2002) Selenate-resistant mutants of *Arabidopsis thaliana* identify Sultr1;2, a sulfate transporter required for efficient transport of sulfate into roots. *Plant J* 29:475–486
- Shimogawara K, Usuda H (1995) Uptake of inorganic phosphate by suspension-cultured tobacco cells: kinetics and regulation of Pi starvation. *Plant Cell Physiol* 36:341–351
- Shimogawara K, Wykoff DD, Usuda H, Grossman AR (1999) *Chlamydomonas reinhardtii* mutants abnormal in their responses to phosphorus deprivation. *Plant Physiol* 120:1–10
- Siderius M, Musgrave A, van den Ende H, Koerten H, Cambier P, van der Meer P (1996) *Chlamydomonas eugametos* (Chlorophyta) stores phosphate in polyphosphate bodies together with calcium. *J Phycol* 32:402–409
- Slomovic S, Portnoy V, Liveanu V, Schuster G (2006) RNA polyadenylation in prokaryotes and organelles; different tails tell different tales. *Crit Rev Plant Sci* 25:65–77
- Smith FW, Rae AL, Hawkesford MJ (2000) Molecular mechanisms of phosphate and sulphate transport in plants. *Biochem Biophys Res Commun* 1465:236–245
- Smith FW, Hawkesford MJ, Ealing PM, Clarkson DT, Vanden Berg PJ, Belcher AR, Warrilow AG (1997) Regulation of expression of a cDNA from barley roots encoding a high affinity sulphate transporter. *Plant J* 12:875–884
- Smith H (1995) Physiological and ecological function within the phytochrome family. *Annu Rev Plant Physiol Plant Mol Biol* 46:289–315
- Somerville CR, Ogren WL (1980) Inhibition of photosynthesis in *Arabidopsis* mutants leaf glutamate synthase activity. *Nature* 286:257–259
- Soupe E, Inwood W, Kustu S (2004) Lack of the Rheus protein Rh1 impairs growth of the green alga *Chlamydomonas reinhardtii* at high CO<sub>2</sub>. *Proc Natl Acad Sci USA* 101:7787–7792
- Stacey G, Koh S, Granger C, Becker JM (2002) Peptide transport in plants. *Trends Plant Sci* 7:257–263
- Stitt M (1999) Nitrate regulation of metabolism and growth. *Curr Opin Plant Biol* 2:178–186
- Stitt M, Krapp A (1999) the interaction between elevated carbon dioxide and nitrogen nutrition: the physiological and molecular background. *Plant Cell Environ* 22:583–621
- Suetsugu N, Wada M (2007) Chloroplast photorelocation movement mediated by phototropin family proteins in green plants. *J Biol Chem* 388:927–935
- Superti-Furga A, Rossi A, Steinmann B, Gitzelmann R (1996) A chondrodysplasia family produced by mutations in the diastrophic dysplasia sulfate transporter gene: genotype/phenotype correlations. *Am J Med Genet* 63:144–147
- Suzuki A, Rothstein SJ (1997) Structure and regulation of ferredoxin-dependent glutamate synthase from *Arabidopsis thaliana*: cloning of cDNA, expression in different tissues of wild-type and *gltS* mutant strains and light induction. *Eur J Biochem* 243:708–718
- Tadano T, Ozawa K, Sakai H, Osaki M, Matsui H (1993) Secretion of acid phosphatase by the roots of crop plants under phosphorus-deficient conditions and some properties of the enzyme secreted by lupin roots. *Plant Soil* 155–156:95–98
- Takahashi H, Yamazaki M, Sasakura N, Watanabe A, Leustek T, de Almeida Engler J, Engler G, Van Montagu M, Saito K (1997) Regulation of sulfur assimilation in higher plants: a sulfate transporter induced in sulfate starved roots plays a central role in *Arabidopsis thaliana*. *Proc Natl Acad Sci USA* 94:11102–11107
- Takahashi H, Watanabe-Takahashi A, Smith F, Blake-Kalff M, Hawkesford MJ, Saito K (2000) The roles of three functional sulphate transporters involved in uptake and translocation of sulphate in *Arabidopsis thaliana*. *Plant J* 23:171–182
- Takahashi H, Braby CE, Grossman AR (2001) Sulfur economy and cell wall biosynthesis during sulfur limitation of *Chlamydomonas reinhardtii*. *Plant Physiol* 127:665–673
- Taylor CB, Green PJ (1991) Genes with homology to fungal and S-gene RNases are expressed in *Arabidopsis thaliana*. *Plant Physiol* 96:980–984



- Taylor CB, Bariola PA, del Cardayré SB, Raines RT, Green PJ (1993) RNS2: a senescence-associated RNase of *Arabidopsis* that diverged from the S-RNases before speciation. *Proc Natl Acad Sci USA* 90:5118–5122
- Trull MC, Guiltinan MJ, Lynch JP, Deikman J (1997) The response of wild-type and ABA mutant of *Arabidopsis thaliana* to phosphorous starvation. *Plant Cell Environ* 20:85–92
- Tsay YF, Chiu CC, Tsai CB, Ho CH, Hsu PK (2007) Nitrate transporters and peptide transporters. *FEBS Lett* 581:2290–2300
- Tucker K, Fadool DA (2002) Neurotrophin modulation of voltage-gated potassium channels in rat through TrkB receptors is time and sensory experience dependent. *J Physiol* 542:413–429
- Turmel M, Otis C, Lemieux C (1999) The complete chloroplast DNA sequence of the green alga *Nephroselmis olivacea*: insights into the architecture of ancestral chloroplast genomes. *Proc Natl Acad Sci USA* 96:10248–10253
- Turmel M, Otis C, Lemieux C (2005) The complete chloroplast DNA sequences of the charophycean green algae *Staurastrum* and *Zygnema* reveal that the chloroplast genome underwent extensive changes during the evolution of the Zygnematales. *BMC Biol* 3:22
- Turmel M, Otis C, Lemieux C (2006) The chloroplast genome sequence of *Chara vulgaris* sheds new light into the closest green algal relatives of land plants. *Mol Biol Evol* 23:1324–1338
- Usami S, Abe S, Weston MD, Shinkawa H, Van Camp G, Kimberling WJ (1999) Non-syndromic hearing loss associated with enlarged vestibular aqueduct is caused by PDS mutations. *Hum Genet* 104:188–192
- Vallon O, Bulte L, Kuras R, Olive J, Wollman FA (1993) Extensive accumulation of an extracellular L-amino-acid oxidase during gametogenesis of *Chlamydomonas reinhardtii*. *Eur J Biochem* 215:351–360
- van der Leij M, Smith SJ, Miller AJ (1998) Remobilization of vacuolar stored nitrate in barley root cells. *Planta* 205:64–72
- Varin L, Marsolais F, Richard M, Rouleau M (1997) Biochemistry and molecular biology of plant sulfotransferases. *FASEB J* 11:517–525
- Veljanovski V, Vanderbeld B, Knowles VL, Snedden WA, Plaxton WC (2006) Biochemical and molecular characterization of AtPAP26, a vacuolar purple acid phosphatase up-regulated in phosphate-deprived *Arabidopsis* suspension cells and seedlings. *Plant Physiol* 142:1282–1293
- Vidmar JJ, Schjoerring JK, Touraine B, Glass ADM (1999) Regulation of the *hvs1* gene encoding a high-affinity sulfate transporter from *Hordeum vulgare*. *Plant Mol Biol* 40:883–892
- Wakasugi T, Nagai T, Kapoor M, Sugita M, Ito M, Ito S, Tsudzuki J, Nakashima K, Tsudzuki T, Suzuki Y, Hamada A, Ohta T, Inamura A, Yoshinaga K, Sugiura M (1997) Complete nucleotide sequence of the chloroplast genome from the green alga *Chlorella vulgaris*: the existence of genes possibly involved in chloroplast division. *Proc Natl Acad Sci USA* 94:5967–5972
- Walch-Liu P, Neumann D, Bangerth F, Engels C (2000) Rapid effects of nitrogen form on leaf morphogenesis in tobacco. *J Exp Bot* 51:227–237
- Wallsgrrove RM, Lea PJ, Mifflin BJ (1983) Intracellular localization of aspartate kinase and the enzymes of threonine and methionine biosynthesis in green leaves. *Plant Physiol* 71:780–784
- Wang YH, Garvin DF, Kochian LV (2002) Rapid induction of regulatory and transporter genes in response to phosphorus, potassium and iron deficiencies in tomato roots: evidence for cross talk and root/rhizosphere-mediated signals. *Plant Physiol* 130:1361–1370
- Warman PR, Sampson HG (1994) Effect of sulfur additions on the yield and elemental composition of canola and spring wheat. *J Plant Nutr* 17:1817–1825
- Weiss M, Bental M, Pick U (1991) Hydrolysis of polyphosphates and permeability changes in response to osmotic shocks in cells of the halotolerant alga *Dunaliella*. *Plant Physiol* 97:1241–1248
- Werner TP, Amrhein N, Freimoser FM (2007) Inorganic polyphosphate occurs in the cell wall of *Chlamydomonas reinhardtii* and accumulates during cytokinesis. *BMC Plant Biol* 7:51
- Wetzel RG (1983) *Limnology* (2nd edn). Saunders College Publishing, Philadelphia, PA
- Wykoff D, Davies J, Grossman A (1998) The regulation of photosynthetic electron transport during nutrient deprivation in *Chlamydomonas reinhardtii*. *Plant Physiol* 117:129–139
- Wykoff D, Grossman A, Weeks DP, Usuda H, Shimogawara K (1999) Psr1, a nuclear localized protein that regulates phosphorus metabolism in *Chlamydomonas*. *Proc Natl Acad Sci USA* 96:15336–15341
- Yao Q, Li XL, Feng G, Christie P (2001) Mobilization of sparingly soluble inorganic phosphates by external mycelium of an arbuscular mycorrhizal fungus. *Plant Soil* 230:279–285
- Yehudai-Resheff S, Zimmer SL, Komine Y, Stern DB (2007) Integration of chloroplast nucleic acid metabolism into the phosphate deprivation response in *Chlamydomonas reinhardtii*. *Plant Cell* 19:1023–1038
- Yildiz FH, Davies JP, Grossman AR (1994) Characterization of sulfate transport in *Chlamydomonas reinhardtii* during sulfur-limited and sulfur-sufficient growth. *Plant Physiol* 104:981–987
- Yildiz FH, Davies JP, Grossman AR (1996) Sulfur availability and the *SAC1* gene control adenosine triphosphate sulfurylase gene expression in *Chlamydomonas reinhardtii*. *Plant Physiol* 112:669–675
- Yoneda Y, Hieda M, Nagoshi E, Miyamoto Y (1999) Nucleocytoplasmic protein transport and recycling of Ran. *Cell Struct Funct* 24:425–433
- Yonekura-Sakakibara K, Onda Y, Ashikari T, Tanaka Y, Kusumi T, Hase T (2000) Analysis of reductant supply

- systems for ferredoxin-dependent sulfite reductase in photosynthetic and nonphotosynthetic organs of maize. *Plant Physiol* 122:887–894
- Yoshimoto N, Takahashi H, Smith WS, Yamaya T, Saito K (2002) Two distinct high affinity sulfate transporters with different inducibilities mediate uptake of sulfate in *Arabidopsis* roots. *Plant J* 29:465–473
- Yoshimoto N, Inoue E, Watanabe-Takahashi A, Saito K, Takahashi H (2007) Posttranscriptional regulation of high-affinity sulfate transporters in *Arabidopsis* by sulfur nutrition. *Plant Physiol* 145:378–388
- Youssefian S, Nakamura M, Sano H (1993) Tobacco plants transformed with the O-acetylserine(thiol)lyase gene of wheat are resistant to toxic levels of hydrogen sulphide gas. *Plant J* 4:759–769
- Zhang D, Lefebvre PA (1997) FAR1, a negative regulatory locus required for the repression of the nitrate reductase gene in *Chlamydomonas reinhardtii*. *Genetics* 146: 121–133
- Zhang L, Melis A (2002) Probing green algal hydrogen production. *Philos Trans R Soc Lond B Biol Sci* 357:1499–1507; discussion 1507–1411
- Zhang H, Jennings A, Barlow PW, Forde BG (1999) Dual pathways for regulation of root branching by nitrate. *Proc Natl Acad Sci USA* 96:6529–6534
- Zhang Z, Shrager J, Jain M, Chang CW, Vallon O, Grossman AR (2004) Insights into the survival of *Chlamydomonas reinhardtii* during sulfur starvation based on microarray analysis of gene expression. *Eukaryot Cell* 3:1331–1348
- Zhao T, Li G, Mi S, Li S, Hannon GJ, Wang XJ, Qi Y (2007) A complex system of small RNAs in the unicellular green alga *Chlamydomonas reinhardtii*. *Genes Dev* 21:1190–1203
- Zhou D, Okamoto M, Vidmar JJ, Glass ADM (1999) Regulation of a putative high-affinity nitrate transporter (nrt2;1At) in roots of *Arabidopsis thaliana*. *Plant J* 17:563–568
- Zhou JJ, Fernandez E, Galvan A, Miller AJ (2000) A high affinity nitrate transport system from *Chlamydomonas* requires two gene products. *FEBS Lett* 466:225–227

# Chapter 16

## Osmolyte Regulation in Abiotic Stress

Arun Lahiri Majumder, Sonali Sengupta, and Lily Goswami  
*Plant Molecular and Cellular Genetics, Bose Institute,  
P-1/12, C I T Scheme VII M, Kolkata 700 054, India*

Summary .....	350
I Introduction.....	350
II Osmolytes and their Types.....	350
A Glycine Betaine .....	351
B Ectoine.....	353
C Trehalose .....	353
D Proline .....	353
E Myo-inositol and Methylated Inositols.....	353
III Regulation of Osmolyte Concentration in Plants: Cell and Organ Level.....	354
A Regulation of Proline Metabolism Under Stress.....	354
B Glycine Betaine in Stress Regulation .....	356
C Myo-Inositol and Its Role in Stress Tolerance .....	356
IV Role of Compatible Solutes/Osmolytes in Other Organisms and Animal Cells .....	358
A Organic Osmolytes in Renal Cells.....	358
B Organic Osmolytes in External Epithelial cells .....	360
C Organic Osmolytes in Brain cells .....	360
V Mechanism of Action of Osmolytes.....	361
A Osmolytes as Chaperones .....	362
B Osmolytes in Stabilization of Proteins .....	363
VI Unique Osmolytes: Glucosylglycerol/Diphosphoinositols .....	364
VII Transgenics with Compatible Solutes for Salinity Stress Tolerance .....	365
VIII Conclusions .....	367
References .....	367

---

\*Author for Correspondence, e-mail: alahirimajumder@yahoo.com

## Summary

To withstand osmotic stress induced by salinity, drought or extreme temperatures, all organisms have evolved a machinery to synthesize metabolites, termed “compatible solutes” or “osmo-protectants”, which help in raising the osmotic pressure and thereby maintaining both the turgor pressure and the driving gradient for water uptake. In addition, these compounds also help in maintaining the structural integrity of enzymes, membranes and other cellular components during the stress regime. Of special importance among these metabolites is nitrogen containing compounds (e.g., quaternary amino compounds and proline) and hydroxyl compounds (e.g., polyols and oligosaccharides). These compounds are distributed throughout the biological kingdom and are generally products of stress-induced pathway extensions, although normal metabolites such as inositols may also act as osmolytes. Chemically, different osmolytes function through a common mechanism of stabilization of proteins under stress or by osmotic adjustments, and these mechanisms seem to be universal among the biological system. Over-expression of genes for the synthesis of different osmolytes in transgenics enables the plants to cope better with the stress due to higher accumulation of the concerned osmolytes. However, in several cases, such as trehalose and inositol, the accumulation is far below the required amount and it is conjectured that these metabolites might function in a manner unrelated to their osmolyte role and are hence more involved in the general growth and development of the plants under abiotic stress conditions.

**Keywords** inositol • osmolyte • osmoprotectants • regulation • stress • sugar alcohols

## I Introduction

Among the various abiotic stresses in nature, water stress exists in the form of drought, salinity and temperature stress. Globally, drought and salinity play major roles in the reduction of crop productivity (Greenway and Munns 1980; Hasegawa et al. 2000; Zhu 2001), while in nature such abiotic stresses actually co-occur, resulting in a compound effect. Drought stress is mainly accompanied by high temperature stress and salinity stress is often associated with low tem-

perature and drought stress. The common effect that all these factors impose on plants is the high osmotic stress.

To withstand osmotic stresses, plants have evolved a machinery to synthesize and accumulate “compatible solutes” or “osmo-protectants”, which help in raising the osmotic pressure and thereby maintain both turgor pressure, as well as the driving gradient for water uptake. In addition, these compounds also help in maintaining the structural integrity of enzymes, membranes and other cellular components during the stress regime.

---

*Abbreviations:* BADH – betaine aldehyde dehydrogenase; CDH – choline dehydrogenase; CMO – choline monoxygenase; COX – choline oxidase; DAPDC – diaminopimelate decarboxylase; DMSP – dimethylsulfoniopropionate; GB – glycine betaine; GG – glucosylglycerol; GIPLs – glycoinositolphospholipids; GPC – glycerophosphocholine; GSA – glutamic-semialdehyde; LPG – lipophosphoglycan; MDCK – Madin-Darby canine kidney cells; mPPG – membrane bound proteophosphoglycan; NHK – normal human keratinocytes; PCO – photosynthetic carbon oxidation; P5C – pyrroline-5-carboxylate; P5CDH – P5C dehydrogenase; P5CR – P5C reductase; P5CS – P5C synthase; ProDH – proline dehydrogenase; QACs – quaternary ammonium compounds; SAM – S-adenosylmethionine; TPP – trehalose-6-phosphate phosphatase; TPS – trehalose-6-phosphate synthase

## II Osmolytes and their Types

Osmolytes can be defined as low molecular weight organic compounds that are used by cells to maintain turgor pressure and cell volume, especially under water stressed conditions. Major osmolytes include amino acids, polyols, sugars and methylamines. They are also termed as “compatible solutes”, because they remain ‘compatible’ with the intracellular machinery of a cell even at high concentrations, in contrast to salt ions which disturb the cellular metabolism of a cell under such adverse conditions.



In addition, under stress conditions, these compounds also play an important role in maintaining the structural integrity of enzymes, membranes, hormones and other cellular components.

A major category of organic osmotic solutes consists of simple sugars (mainly fructose and glucose), sugar alcohols (glycerol and methylated inositols) and complex sugars (trehalose, raffinose and fructans); others include quaternary amino acid derivatives (proline, glycine betaine,  $\beta$ -alanine betaine, proline betaine), tertiary amines (ectoine; 1,4,5,6-tetrahydro-2-methyl-4-carboxypyrimidine) and sulfonium compounds (choline o-sulfate, dimethyl sulfonium propionate).

The accumulation of compatible solutes in response to osmotic stress is ubiquitously present in diverse organisms, from bacteria to plants and animals. Various compatible osmolytes can greatly reduce stress damage to bacteria, animal and plant cells (Greenway and Munns 1980; Hasegawa et al. 2000).

Chemically, osmo-protectants or osmolytes can be broadly classified into three types: betaines (fully N-methylated amino acid derivatives) and related compounds [dimethylsulfoniopropionate (DMSP) and choline-o-sulfate]; certain amino acids (proline and ectoine); polyols (*myo*-inositol, pinitol and other methylated inositols) and non-reducing sugars (trehalose). In plant cells, osmo-protectants are mainly restricted to the cytosol, chloroplast and other cytoplasmic compartments (that together constitute 20% or less of the mature cell volume, while the other 80% is constituted by the large central vacuole). These concentrations play crucial roles in maintaining the cell turgor pressure and producing the driving gradient for water uptake under stress conditions (Rhodes and Samaras 1994). Among the different osmo-protectants, proline, glycine betaine and mannitol occur commonly in plants, while DMSP, choline-o-sulfate, D-ononitol and trehalose occur not so often in plants. Ectoine, on the other hand, is found uniquely in bacteria. Some of the common osmolytes and their pathways of synthesis are presented in Fig. 1.

### A Glycine Betaine

Quaternary ammonium compounds (QACs) are an important class of osmo-protectants found in plants, bacteria, marine algae and animals,

while glycine betaine is one of the commonest QACs found in the biological kingdom. It occurs in higher plants as well as in bacteria and other organisms. It is synthesized from either choline or glycine via two distinct pathways, i.e., dehydrogenation of choline or N-methylation of glycine.

In *Escherichia coli*, a membrane-bound, electron transfer-linked choline dehydrogenase (CDH) oxidizes choline to betaine aldehyde. The aldehyde is then oxidized to glycine betaine by a NAD-linked betaine aldehyde dehydrogenase (BADH) (Andresen et al. 1988). In contrast, *Arthrobacter globiformis* and a closely related strain *Arthrobacter pascens* requires only one enzyme, choline oxidase (COX) (Ikuta et al. 1977). In plants, however, the first oxidation is mediated by a ferredoxin-dependent choline mono-oxygenase (CMO) (Rathinasabapathi et al. 1997), and the second by BADH (Rathinasabapathi et al. 1994). Both plant enzymes are chloroplastic (Fig. 2). All these enzymes have also been used to engineer tobacco and other plants that lack glycine betaine, generally by placing the transgenes under the control of CaMV 35S promoter, and in most cases an increase in stress tolerance has also been reported.

In plants belonging to plumbaginaceae, well known for their stress tolerance, other QACs are preferred over glycine betaine. In addition to the pathway for synthesis of glycine betaine, plants of this family can synthesize other QACs like choline o-sulfate and the betaines of alanine, proline and hydroxyproline, using the common substrate choline selectively under different stress conditions. These osmolytes might have different roles in such conditions. In particular, choline-o-sulfate is suggested to be involved in sulfate detoxification along with its role as an osmo-protectant. The idea behind this notion is that the salt glands of these plants can excrete out chloride but not sulfate, which can lead to sulfate toxication. But the conjugation of sulfate with choline, as in choline-o-sulfate, may lead to the removal of this excess sulfate and convert it into a useful compatible solute (Hanson and Burnet, 1994).

$\beta$ -alanine betaine has also been preferred over glycine betaine in the course of evolution (Hanson and Gage 1991; Hanson and Burnet 1994). The reason behind this preference might be the independence from choline availability in the

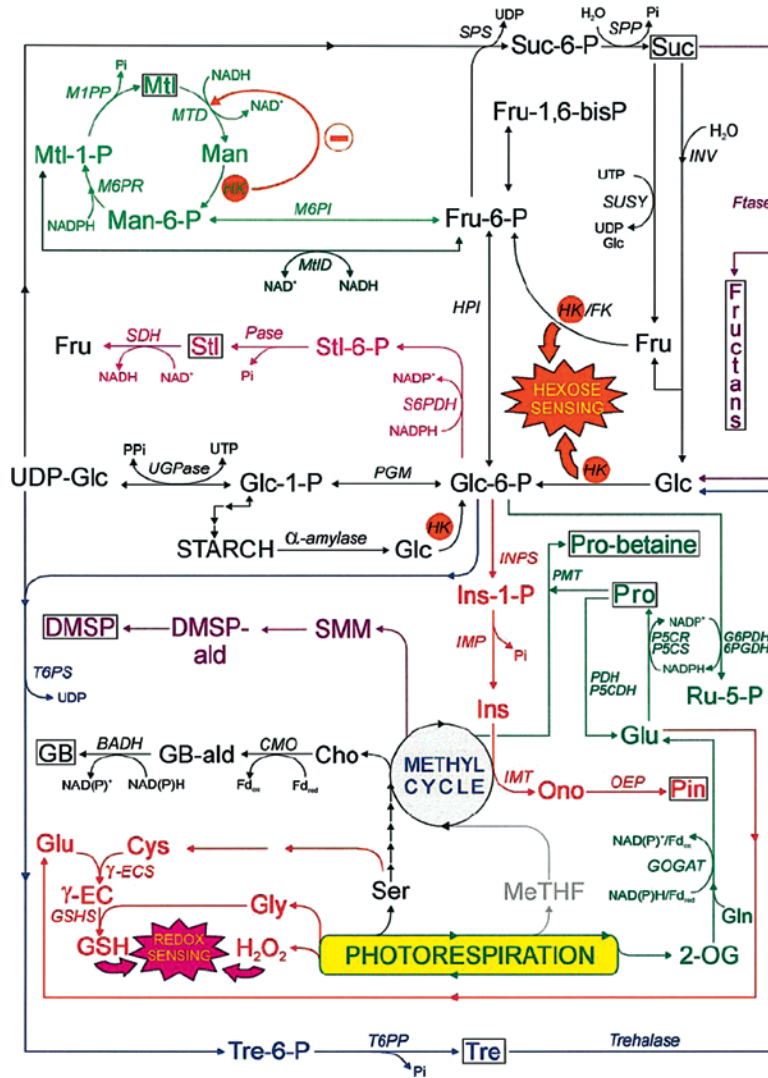

Fig. 1. Various osmolytes and their pathway of synthesis (Adapted from Hare et al. 1997).

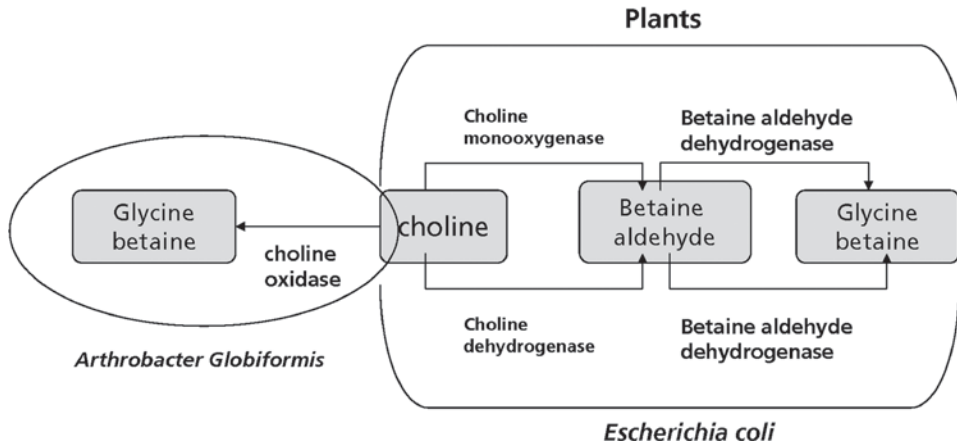

Fig. 2. Different pathways for synthesis of glycine betaine.

synthesis of this QAC. Moreover, the synthesis of  $\beta$ -alanine betaine does not require oxygen. This fact can be used to hypothesize it to be suitable for osmo-protection under oxygen depleted conditions like saline and hypoxic conditions (Hanson and Burnet, 1994; Rathinasabapathi et al. 2000). It is also known to have cholesterol-reducing effects (Abe and Kaneda 1973).

### B Ectoine

Ectoine (1,4,5,6-Tetrahydro-2-methyl-4-pyrimidinocarboxylic acid) was first identified in *Ectothiorhodospira halochloris*, and is found in a wide range of gram-negative and gram-positive bacteria. It is generally found in *Halomonas elongata* and other halophilic bacteria and is synthesized from aspartate semialdehyde in three steps (Ono et al. 1999) and the three genes involved in this synthesis are ectA, ectB and ectC. In the gram-positive moderate halophile *Marinococcus halophilus*, ectA codes for L-2,4-diaminobutyric acid acetyltransferase, ectB for L-2,4-diaminobutyric acid transaminase and ectC for L-ectoine synthase. When these three genes encoding the enzymes of ectoine synthesis were cloned in a single construct driven by the constitutive CaMV 35S promoter and introduced into cultured tobacco cells, transformed cell lines synthesized low levels of ectoine and showed a diminutive increase in resistance to osmotic stress imposed with mannitol (Nakayama et al. 2000). Functional expression of the genes in *E. coli*, however, resulted in increased cytoplasmic ectoine concentration in response to salt-growth (Louis and Galinski 1997).

### C Trehalose

Trehalose is a non-reducing disaccharide of glucose that mainly acts as a compatible solute and plays a significant role as an osmo-protectant in stabilizing dehydrated enzymes, membrane lipids and biological structures during desiccation. In bacteria and yeast, trehalose is synthesized in two steps: the first step synthesizes trehalose-6-phosphate from glucose-6-phosphate and uridine diphosphoglucose, catalyzed by trehalose-6-phosphate synthase (TPS), and the second by trehalose-6-phosphate phosphatase (TPP) to produce free trehalose. The enzyme trehalase breaks it down to two molecules of glucose.

Trehalose is accumulated in many bacteria, fungi, invertebrates and in a few resurrection plants, a group of extreme desiccation-tolerant plants, which can tolerate complete dehydration and spring back to life upon rehydration (Crowe et al. 1992; Welsh and Herbert 1999; Argüelles 2000). In addition to its assumed role as an osmolyte or osmo-protectant, recent studies point towards its more specific role in plant growth and development (Grennan 2007).

### D Proline

Proline is a compatible solute involved in scavenging free radicals and stabilizing sub-cellular structures (Smirnoff and Cumbes 1989). In plants, proline accumulates either through an increase in its synthesis or through an inhibition of its degradation (Delauney and Verma 1993; Yoshida et al. 1997). Proline is synthesized from glutamate via glutamic-semialdehyde (GSA) and D1-pyrroline-5-carboxylate (P5C). P5C synthase (P5CS) catalyzes the conversion of glutamate to P5C, followed by P5C reductase (P5CR), which reduces P5C to proline. Proline is also metabolized to glutamate in a feedback manner via P5C and GSA with proline dehydrogenase (ProDH), followed by P5C dehydrogenase (P5CDH). Proline accumulation is a well documented response to osmotic stress in plants (Singh et al. 1972). Although, all studies are focused on the ability of proline to be involved in osmo-tolerance, its specific role in plants remains largely unclear.

### E Myo-inositol and Methylated Inositols

Inositols are 6-carbon cyclohexane hexitols representing any one of eight diastereoisomeric structures and exist in nine stereoisomeric forms. Myo-inositol is a meso compound with a plane of symmetry that rotates the structure about C2 and C5, which are fixed positions. While, the remaining four carbon atoms consist of two prochiral pairs, C1=C3 and C4=C6. Different methyl-inositols having various chemical structures are derived through methyl transferases of different specificities (Fig. 3).

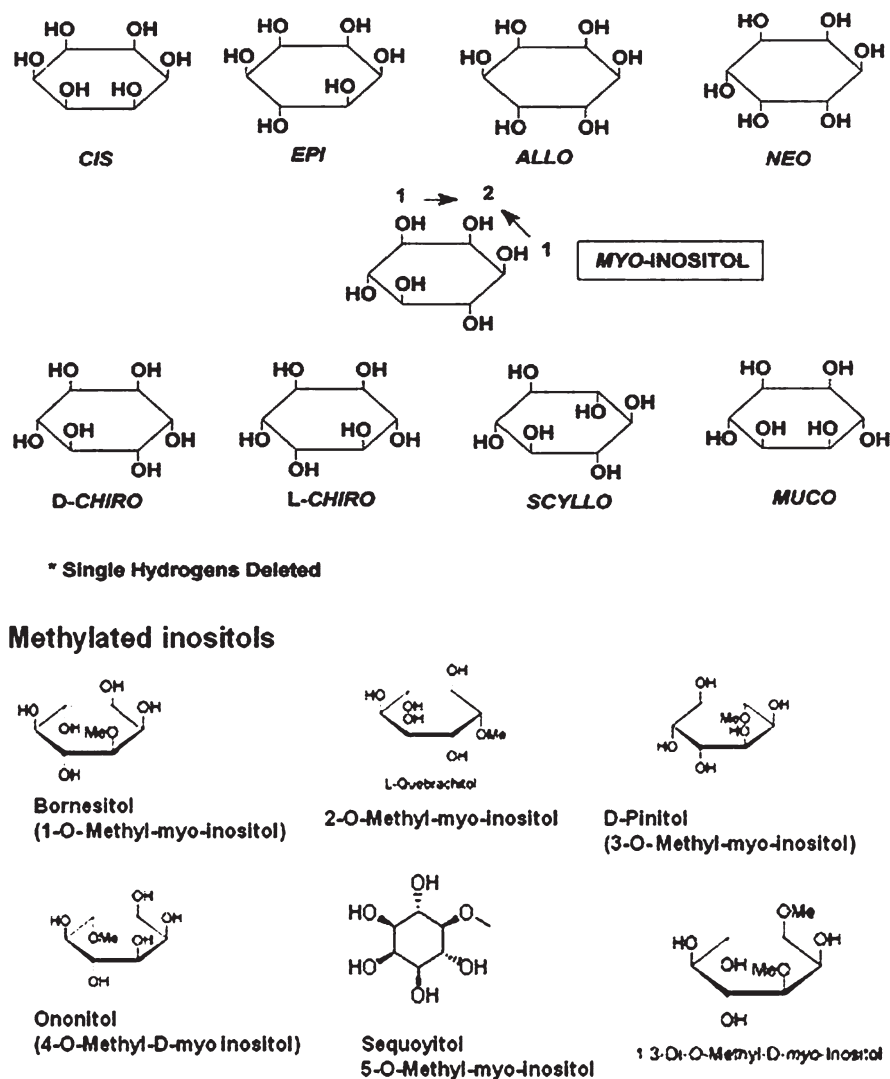

Fig 3. Isomeric inositols and methylated inositols.

### III Regulation of Osmolyte Concentration in Plants: Cell and Organ Level

On exposure to osmotic stress, as a result of drought, high salinity and low temperature, plants also frequently accumulate a range of metabolically benign compatible solutes or osmolytes to maintain the turgor pressure and display other protective effects on macromolecules present in dehydrating cells. The solutes accumulated vary between species and include proline, betaines, dimethylsulfoniopropionate (DMSP), polyols (mannitol, sorbitol, pinitol), trehalose and fructans. Over the past several years, a number of transgenic plants have been produced

in which over-accumulation occurs (e.g., proline) or in which the ability to accumulate osmolytes not previously present has been introduced. The results suggest that they can improve plant growth during osmotic stress even at osmotically-insignificant levels. In plants, osmolytes might serve as valuable storage compounds for reducing power and a source of carbon and/or nitrogen upon relief from stress.

#### A Regulation of Proline Metabolism Under Stress

Since primary capture of photon energy is insensitive to stress, plants under adverse conditions



are frequently exposed to light intensities in excess of those that can be used for carbon assimilation. If the regeneration of  $\text{NADP}^+$  is limited under conditions of continued photon absorption, redox imbalance is likely to result in photo-inhibition and enhanced use of  $\text{O}_2$  instead of  $\text{NADP}^+$ , as the electron acceptor in the process of photosynthesis. Thus, in addition to any biophysical protective effects of free proline, which may also be of importance, it has been proposed that a stress-induced increase in the transfer of reducing equivalents to proline, by D1-pyrroline-5-carboxylate (P5C) synthetase and P5C reductase, may also be a protective mechanism as shifts in cellular redox potential accompany all biotic and abiotic stresses, including those that do not cause cellular dehydration (Hare and Cress 1997). This may assist in counteracting photo-inhibitory damage under adverse conditions. A cycle of proline synthesis and degradation might be responsible for sensitive regulation of cellular redox potential in the cytosol or plastid.

Onset of severe dehydration in *Arabidopsis* is associated with induction of both proline dehydrogenase and P5C synthetase, with no net accumulation of free proline, which corroborates the notion that cycling between proline and its precursors may be an important homeostatic mechanism to forestall redox imbalance, associated with small water deficits of the order of those experienced on a daily basis. Thus, enhanced flux through this substrate cycle may confer a yield advantage, at least under modest stress, although uncoupling of the process under severe stress might overwhelm the benefit. Interestingly, an isoform of P5C dehydrogenase, most abundant in exponentially growing *Nicotiana plumbaginifolia* cells, displayed significantly greater specific activity when the culture medium was supplemented with NaCl, even though proline accumulation was noted.

Patterns of accumulation of transcript encoding P5C reductase in *Arabidopsis* and transcription of the same gene, suggest an important role for proline synthesis in the rapidly dividing cells. In case of *Arabidopsis*, P5C synthetase is encoded by two differentially regulated genes. Divergence of the biochemical function(s) of P5C synthetase isoforms, which have also been observed in alfalfa (GenBank entries X98421; X98422) and tomato, is indicated by the observation that expression of

the *AtP5CS1* gene occurs in differentiated tissues, but cannot be detected in dividing cell cultures in the absence of a stress stimulus. The recently identified *AtP5CS2* gene from *Arabidopsis* is solely responsible for the abundant synthesis of P5C synthetase mRNA in rapidly dividing cell cultures. Interestingly, the G-glutamyl kinase activity of one tomato P5C synthetase isoform is 70–250 times more sensitive to feedback inhibition by proline, than the recombinant P5C synthetase characterized from *Vigna aconitifolia*.

P5C, an intermediate in proline biosynthesis and catabolism, can selectively increase the expression of at least three osmotically regulated genes in rice (*Oryza sativa* L.). Their findings suggest that a signal derived from the proline biosynthetic and catabolic pathways, possibly the redox potential of the pyridine nucleotide pools, may control gene expression in response to osmotic stress. Plants that were treated with P5C or 3,4-dihydroproline consumed less  $\text{O}_2$ , had reduced NADPH levels and increased NADH levels, and accumulated many osmolytes associated with osmotically stressed rice.

It has been implied that in response to osmotic stress, proline accumulation is regulated at the transcriptional level for both biosynthesis activation through P5CS and catabolism repression through PDH. In the model legume plant *M. truncatula*, three cDNAs encoding D1-pyrroline-5-carboxylate synthetase (P5CS1, P5CS2; EC not assigned) and ornithine d-amino-transferase (OAT; EC 2.6.1.13) were isolated. The two P5CS genes showed differing transcript level regulation according to the organs and in response to osmotic stress. MtP5CS1 steady-state transcript levels, in the different plant organs, were correlated with proline levels but transcript abundance was unaffected by osmotic stresses. MtP5CS2 transcripts were poorly detected in all organs but were strongly accumulated in shoots of salt-stressed plants. Specifically different roles of MtP5CS1 and MtP5CS2 as a housekeeping isoform and as a stress specific isoform, respectively, were suggested. MtOAT transcripts were predominantly detected in roots and shoots of unstressed plants, while salt-stress treatment induced the accumulation of MtOAT transcripts in the whole plant, whatever the developmental stage. In salt-stressed roots, a positive correlation was found between proline and MtOAT transcript accumulation.

These results suggest that both ornithine and glutamate biosynthesis pathways contribute to the osmotic stress-induced proline accumulation in *M. truncatula* (Armengauda et al. 2004).

### B Glycine Betaine in Stress Regulation

Glycine betaine synthesis in the chloroplast stroma proceeds by a two-step oxidation of choline via the unstable intermediate betaine aldehyde [choline is oxidized by choline mono-oxygenase (CMO) to betaine aldehyde, which is converted to glycine-betaine by BADH] and can accumulate to high levels (>20 mM on a tissue water basis) in some plants, like spinach and sugar beet, under osmotic stress. High rates of glycine betaine synthesis must increase the demand for its ultimate precursor, i.e., serine. In the presence of light, the photosynthetic carbon oxidation (PCO) cycle provides substantial amounts of serine in the leaves of C3 plants. While in photosynthetic tissues, non-photorespiratory routes for the production of serine are of minor significance compared to the activity of the PCO cycle during the day. Light is also essential for the salt-responsive increase in three cytosolic S-adenosylmethionine (SAM) dependent N-methylation reactions involved in choline synthesis in case of spinach (Weretilnyk et al. 1995). Despite an ability to down-regulate choline synthesis, glycine betaine deficiency in maize (*Zea mays*) was associated with accumulation of serine and a significant expansion of the free choline pool.

Two *Sorghum bicolor* cDNA clones BADH1 and BADH15 are known to be induced under water deficit and their expression coincided with the accumulation of glycine betaine. The accumulation of this compatible solute significantly contributed to an increased osmotic potential and allowed a maximal osmotic adjustment of 0.405 MPa (Hare et al. 1998; Kotchoni and Bartels 2003).

### C Myo-Inositol and Its Role in Stress Tolerance

Throughout the biological kingdom, *myo*-inositol is synthesized by a two-step pathway. The first step in *myo*-inositol biosynthesis is the conversion of D-glucose-6-P to 1L-MI-1-P, which is catalyzed by an evolutionarily conserved L-*Myo*-inositol 1-phosphate synthase (MIPS; EC 5.5.1.4),

followed by its specific dephosphorylation to free *myo*-inositol by the Mg<sup>++</sup> dependent L-*Myo*-inositol 1-phosphate phosphatase (EC 3.1.3.25) (Loewus and Loewus 1983; Majumder et al. 1997, 2003). Production of other stereo-forms of inositol, after proper metabolic processing, leads to a large variety of functions, all of which require the presence of this unique cyclitol.

MIPS exists in two forms, i.e., cytosolic and chloroplastic. Although the cytosolic form of MIPS has been reported from a wide range of plant and animal sources, the chloroplastic form of the enzyme has so far been demonstrated only in pea (Imhoff and Bourdu 1973), *Vigna radiata* and *Euglena gracilis* (Adhikari et al. 1987), and *Oryza sativa* (RayChaudhuri and Majumder 1996).

The structural gene *INO1*, responsible for production of MIPS, was first isolated from the yeast *Saccharomyces cerevisiae* (Donahue and Henry 1981). Now more than 60 genes homologous to *INO1* and belonging to a number of other organisms, notably higher plants, fungi, protozoa, eubacteria, archaea and parasites, have been reported (Majumder et al. 2003). Different authors have designated the gene differently, e.g., *tur1* in *Spirodela polyrrhiza* (Smart and Fleming 1993), *Caln1* in *Candida albicans* (Klig et al. 1994), *c-ino1* in *Citrus paradisi* (Abu-Abied and Holland 1994) and *INPS1* in *Mesembryanthemum crystallinum* (Ishitani et al. 1996). The first plant gene for MIPS to be isolated and characterized was *tur1*, a cDNA from the duckweed, *Spirodela polyrrhiza*. This gene was found to be spatially upregulated during an ABA-induced morphogenic response (Smart and Fleming 1993). Transgenic *Arabidopsis* plants over-expressing the *tur1* cDNA from *S. polyrrhiza* were also generated (Smart and Flores 1997), and it successfully contained elevated MIPS activity showing almost a fourfold increase in endogenous *myo*-inositol. Salt-tolerant varieties of rice grown in a NaCl environment exhibited a photo-responsive enhancement of chloroplast and cytosolic MIPS activity (Raychaudhuri and Majumder 1996). This observation led to the conclusion that there is a possible role of free *myo*-inositol, as an osmolyte, in the chloroplast through coordinated activation or induced expression of MIPS and *myo*-inositol monophosphatase.

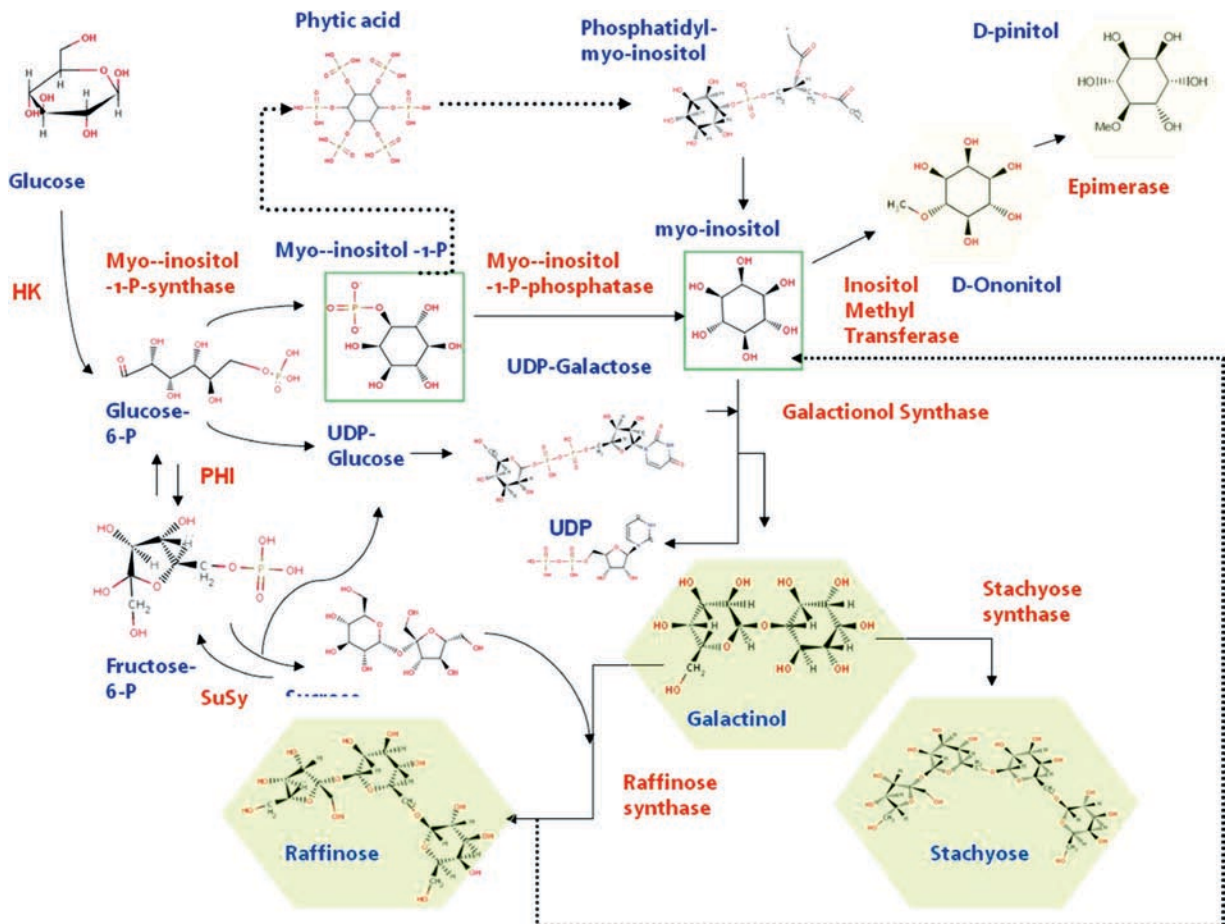

Fig. 4. Inositol utilization in synthesis of various osmolytes.

Extension of the *myo*-inositol pathway to other metabolites of importance and to stress regulation, such as methyl-inositols or galactinols and RFOs, is presented in Fig. 4. Stress-related responses involving inositol or *o*-methyl inositol have been extensively studied and it has been observed that the inositols and their *o*-methyl ethers contribute to osmotic regulation in a broad variety of naturally occurring plants that have been exposed to stressful abiotic environments (Timmerman et al. 1983). In the halophytic ice plant *Mesembryanthemum crystallinum*, a model plant for studies involving induced crassulacean metabolism, it was found that the plants irrigated with 400 mM sodium chloride accumulated pinitol which constituted over two-thirds of the soluble carbohydrate fraction and approximately 10% of the dry weight (Paul and Cockburn 1989). The osmotic

adjustment of this plant was thus credited to its high level of pinitol.

Analysis of an *INO1*-like transcript, termed INPS1 from salt-stressed ice plant revealed a diurnal fluctuating increase in its mRNA during the light period. During salt growth, a coordinated transcriptional regulation of *INPS1* and the *IMT1* gene, encoding *myo*-inositol-*o*-methyltransferase, was discernible enabling the system to drive the generated *myo*-inositol pool towards production of pinitol via ononitol (Ishitani et al. 1996). D-pinitol is considered to be the principal osmo-regulator in this case. However, similar experiments with *Arabidopsis thaliana* failed to demonstrate this effect indicating the absence of any stress mediated induction of MIPS mRNA in *Arabidopsis* and similar observations were made by Smart and Flores (1997). Transgenic tobacco

plants introgressed with *IMT1*, were found to accumulate ononitol and provided better protection under drought and salt-stress conditions than the wild-type plants (Sheveleva et al. 1997). It was later discovered that there is an increased phloem transport of *myo*-inositol, associated with increased transport of  $\text{Na}^+$  and inositol, to leaves of the ice plant under stressed conditions (Nelson et al. 1998). It was also found that the seedlings of ice plants, which are salt sensitive, developed patterns of gene expression and polyol accumulation as observed in mature salt-tolerant plants and that in *myo*-inositol enhanced  $\text{Na}^+$  uptake and its transport (Nelson et al. 1999). From all this data it was proposed that a  $\text{Na}^+$ -*myo*-inositol symport probably existed that promoted  $\text{Na}^+$  uptake in the ice plant.

A unique salt-tolerant MIPS coding gene (*PcINO1*) has been isolated from the halophytic wild rice *Porteresia coarctata* and studied extensively (Majee et al. 2004). The *PcINO1* protein differs from the corresponding *OsINO1* protein from the domesticated rice, *Oryza sativa* in a 37 amino acid stretch which has been shown to be responsible for the salt-tolerant character of the *PcINO1* protein (Ghosh Dastidar et al. 2006). Introgression of the *PcINO1* gene in evolutionarily diverse organisms, including higher plants, has been shown to confer salt-tolerance to the transgenic systems concomitant with higher accumulation of inositol (Das-Chatterjee et al. 2006).

Conversion of *myo*-inositol to galactinol or to other raffinose series oligosaccharides (Fig. 4) under abiotic stress was studied in *Arabidopsis*. Seven galactinol synthase genes (*GolS*) were isolated and their transgenic over-expression concomitant with accumulation of galactinol, stachose or raffinose was correlated with adaptation during drought, salinity or cold stress (Taji et al. 2002). These results point towards the important osmo-protectant role of these compounds during abiotic stress.

#### IV Role of Compatible Solutes/Osmolytes in Other Organisms and Animal Cells

In *Lysteria monocytogenes* – a food-borne pathogen (capable of surviving in extreme conditions such as high salinity as well as low temperature); glycine betaine plays a major role in assisting the

organisms to thrive under such stressed conditions. Later, many other osmolytes were also found to be involved in such machinery. These include proline betaine, acetylcarnitine, gamma-butyrobetaine and 3-dimethylsulfonylpropionate (Bayles and Wilkinson 2000).

Yeast also utilizes the osmotic cushion provided by these osmolytes under environmental fluctuations. In the stress tolerant yeasts, like *Zygosaccharomyces rouxii* and *Pichia sorbitophila*, and the less tolerant *Saccharomyces cerevisiae*, it was found that all these cells released glycerol during hypo-osmotic stress. *Z. rouxii* was specifically observed to release arabinol, while *P. sorbitophila* released erythritol as well as arabinol in addition to glycerol. Since, the extracellular amounts of the osmolytes increase with increased stress, it was concluded that the osmolytes released were not metabolized. This pointed towards the typical role of osmolytes in sustaining the cell volume and maintaining turgor pressure in the osmotically stressed cells. This also signifies the role of channel proteins that help in the transport of these osmolytes. Thus, the exact mechanism at molecular level still needs to be studied in great details (Kayingo et al. 2001).

Nitrogen fixing rhizosphere bacteria *Azospirillum* also exploits osmolytes for survival under high concentrations of sodium chloride, sucrose or polyethylene glycol. In both *A. brasilense* and *A. halopraeferens*, the compatible solute was trehalose glutamate, while *A. halopraeferens* additionally uses glycine betaine. A new bacterium from this genus (strains BE and TC) isolated from rhizosphere of rice were found to be salt tolerant and showed production of ectoine during osmotic stress (Hartmann et al. 1991).

*Cryptococcus neoformans*, which is an opportunistic and encapsulated basidiomycetes yeast, uses inositol as the sole source of carbon. The inositol synthetic and catabolic pathways are regulated in opposition, i.e., repressing conditions for one are inducing conditions for the other. This inositol catabolism has been suggested to be a virulence factor contributing to capsule formation or composition (Molina et al. 1999).

#### A Organic Osmolytes in Renal Cells

Renal cells comprise major sites of action of osmolytes. Kidney cells are bound to face high



osmotic stresses due to the presence of high concentrations of NaCl and urea in blood and interstitial fluid in renal medulla. They protect their cells by the accumulation of organic osmolytes.

Five major osmolytes control the osmotic balance of renal medullary cells: glycerophosphocholine (GPC), inositol, sorbitol, betaine and taurine (Garcia-Perez and Burg, 1991). It is assumed that they serve as compatible solutes whose variable accumulation maintains cell volume and electrolyte content in the face of varying hypertonicity. Madin-Darby canine kidney cells (MDCK) accumulate these osmolytes through specific Na<sup>+</sup>-coupled transporters when cultured in a hypertonic medium. *Myo*-inositol is the only osmolyte found in considerable amounts in the cortex, outer medulla and inner medulla of kidney and is solely used for maintenance of the osmotic balance (Yamauchi et al. 1996). In *Leishmania mexicana*, several *myo*-inositol containing GPI-anchored molecules like the proteins Leishmanolysin (gp63), gp46/PSA2 or membrane bound proteophosphoglycan (mPPG), as well as lipophosphoglycan (LPG), and a group of glycoinositolphospholipids (GIPLs), have been shown to be present on the surface of *Leishmania* and have been implicated in its virulence to the mammalian host and the vector sandfly (Ilg 2002).

The compatible osmolytes hypothesis predicts that by accumulating such organic solutes, rather than NaCl or KCl, cells can safely adapt to hypertonicity. However, the total concentration of these solutes seems to act as the main factor controlling the osmoticum of renal cells and not specific properties of the individual solutes. There is evidence that renal cells show coordinated regulation of organic osmolytes. At a given tonicity, renal cells minimize changes in the total concentration of compatible osmolytes by altering relative amounts of osmolytes, and this control occurs via regulation of the same processes that are activated to accumulate the organic osmolytes in response to hypertonicity.

Hypertonicity increases transcription of the aldose reductase and betaine transporter genes, ultimately elevating cell sorbitol and betaine. Inhibition of aldose reductase, to prevent accumulation of sorbitol, along with increased expression of betaine transporter gene(s), results in a higher concentration of betaine in cells. Conversely, when cell betaine was tentatively altered by

changing its concentration in the medium, aldose reductase transcription changes reciprocally, resulting in compensating changes in cell sorbitol. Hypertonicity increases GPC by inhibiting GPC:choline phosphodiesterase (GPC:PDE), an enzyme that degrades GPC. When cell betaine or inositol is increased, by raising its concentration in the medium, GPC:PDE activity rises, hence reducing cell GPC (Burg 1996). The amino acid taurine (2-aminoethanesulfonic acid), an important osmolyte in kidney, is of particular interest in that its body pool size is governed by renal transport activity. In many tissues, taurine is found as a major free intracellular amino acid. High intracellular taurine concentrations in tissues, reported to have limited capacity for taurine biogenesis, indicate that taurine is probably taken up against a concentration gradient from extracellular fluid. In the kidney, most filtered taurine is reabsorbed in the proximal tubule by a sodium- and chloride-coupled transporter (Matsell et al. 1997). The sodium and chloride requirement of the taurine transporter reflect a postulated stoichiometry of 2 Na<sup>+</sup>: 1 Cl<sup>-</sup>: 1 taurine. Such coupling explains intracellular accumulation of taurine against a steep concentration gradient. The activity of the co-transporter in the brush border of the proximal tubule contributes to whole-body homeostasis of taurine, activity increases in animals fed diets deficient in taurine- and sulfur-containing amino acids. Expression of this co-transporter is again restricted to the Loop of Henle and the glomerular epithelia and its mRNA expression, which increases in vitro in response to a hyperosmolar medium (500 LM raffinose), as demonstrated in MDCK cells.

As suggested that there is a common factor or event in the response to hypertonicity that regulates the accumulation of osmolytes, so that the impaired accumulation of one is compensated by another, the maintenance of high levels of taurine transporter activity in hypertonic cells is related to *myo*-inositol concentration in cell. Cells grown in *myo*-inositol-deficient medium show increased uptake of taurine reflecting such an interaction between the accumulation of taurine and *myo*-inositol. There is a growing body of evidence firmly establishing a major role for taurine in cellular adaptation to osmotic stress by modulating cell volume. Exposure of a variety of cultured cells to a hypotonic solution results in cellular

extrusion of taurine, a process which contributes to regulatory volume decrease. Conversely, exposure of cells to hypertonic media results in cellular uptake of taurine, an important mechanism in regulatory volume increase (Uchida et al. 1991; Matsell et al. 1997).

Thus, although the different renal organic osmolytes are chemically distinct and are accumulated by diverse mechanisms, the level of each is regulated by the others and total osmolyte concentration is maintained. A likely explanation is that all respond to a common signal that is unrelated to the specific properties of each. The signal most likely is intracellular ionic strength. Upon exposure to hypertonicity, before organic osmolytes have accumulated, the intracellular ionic strength should rise in parallel to the osmolality. Then, as organic osmolytes accumulate, the intracellular ionic strength should decrease, diminishing the signal for organic osmolyte accumulation (Burg 1996).

### *B Organic Osmolytes in External Epithelial cells*

Osmolytes do not only serve a role in cell volume homeostasis, but also protect other cell types by virtue of their capacity to stabilize proteins against osmotic shock and hyperoxidation. Endogenous protection strategies of the human skin cells specially that of epidermal keratinocytes, the primary cellular targets for environmental hassle, also include modulation of osmolyte transportation. Primary normal human keratinocytes (NHK) express mRNA specific for the betaine/GABA transporter, for the sodium-dependent *myo*-inositol transporter and for the TAUT (taurine transporter). In comparison to normoosmotic (305 mOsmol/L) controls, a threefold to fivefold induction of mRNA expression for the betaine/GABA-, the sodium-dependent *myo*-inositol and the TAUT was observed within 6–24 h after hyperosmotic exposure (405 mOsmol/L). Expression of osmolyte transporters was associated with an increased uptake of radiolabeled osmolytes. Conversely, hypoosmotic (205 mOsmol/L) stimulation induced significant efflux of these osmolytes. Exposure to ultraviolet B (290–315 nm) or ultraviolet A (340–400 nm) radiation, which are major sources of oxidative stress in skin, significantly stimulated osmolyte uptake.

Increased osmolyte uptake was associated with upregulation of mRNA steady-state levels for osmolyte transporters in irradiated cells.

These studies demonstrate that NHK possess an osmolyte strategy, which is important for their capacity to maintain cell volume homeostasis and seems to be part of their response to UV radiation (Warskulat et al. 2004).

### *C Organic Osmolytes in Brain cells*

In the brain the maintenance of volume of neuronal cells and glial cells is very important for signal processing and transmission. Obvious enough, the mechanism of regulation to osmotic stress is also well developed in the brain, the most complex animal organ, despite the blood-brain barrier which prevents rapid changes in plasma osmolality. Brain cells respond to increased osmolality of the extracellular fluid by accumulating inorganic electrolytes and nonperturbing organic osmolytes to limit the extent of brain cell shrinkage. *Myo*-inositol, glutamate, glutamine and taurine are the major osmolytes in the brain.

Plasma osmolality, a major determinant of total body water homeostasis, is measured by the number of solute particles present in 1 kg of plasma calculated in mmol per L. Total body sodium is primarily extracellular, and any increase results in increased tonicity, causing increased water reabsorption. Brain cell swelling due to osmotic imbalance and subsequent increase in cell volume is a severe disease called Hyponatremia. Hyponatremia exerts most of its clinical effects on the brain and is commonly defined as a serum sodium concentration 135 meq/L. An acute onset (usually in <24 h) of hyponatremia causes severe, and sometimes fatal, cerebral edema. Given time, the brain adapts to hyponatremia, permitting survival despite extraordinarily low serum sodium concentrations. Adaptation to severe hyponatremia is critically dependent on the loss of organic osmolytes from brain cells. These intracellular, osmotically active solutes contribute substantially to the osmolality of cell water and do not adversely affect cell functions when their concentration changes. The adaptation that permits survival in patients with severe, chronic (>48 h duration) hyponatremia also makes the brain vulnerable to injury (osmotic demyelination) if the electrolyte disturbance is corrected too rapidly.

The re-uptake of organic osmolytes after correction of hyponatremia is slower than the loss of organic osmolytes during the adaptation to hyponatremia. Areas of the brain that remain most depleted of organic osmolytes are the most severely injured by rapid correction. The brain's re-uptake of *myo*-inositol, one of the most abundant osmolytes, occurs much more rapidly in a uremic environment, and patients with uremia are less susceptible to osmotic demyelination. In an experimental model of chronic hyponatremia, exogenous administration of *myo*-inositol speeds the brain's reuptake of the osmolyte and reduces osmotic demyelination and mortality caused by rapid correction (Richard et al. 2006).

Rapid up-regulation of  $\text{Na}^+/\textit{myo}$ -inositol co-transporter (SMIT) mRNA expression was observed in response to acute hypermatremic stimulation which suggests that *myo*-inositol plays a major role as an osmolyte in the brain. *Myo*-inositol concentration was also reported to be increased significantly in the brain during chronic hypematremia.

Genes involved in the accumulation of taurine, taurine transporter and consensus for mammalian osmotic response elements, taurine biosynthetic enzymes, may be upregulated in brain when the plasma was made hyperosmotic through salt-loading like the genes involved in the accumulation of other osmolytes, sorbitol, *myo*-inositol and betaine. The upregulation of the taurine transporter gene appears induced by hyposmolar stress and energy deprivation, and taurine biosynthetic enzymes appear thus to be encoded by putative osmo-sensitive genes. Taurine related genes may possess in their 5' flanking region an osmotic responsive element similar to that previously identified in the established osmo-sensitive genes coding for aldose reductase, *myo*-inositol and betaine transporter. However the actual upregulation of each of these putative or established osmo-sensitive genes shows specific features as to its amplitude, time course and regional occurrence. This indicates that in brain cells there are other factors which selectively modulate or repress the hyperosmolarity-induced upregulation of these genes that remain to be identified.

Rapid up-regulation of  $\text{Na}^+/\textit{myo}$ -inositol co-transporter (SMIT) mRNA expression was observed in response to acute hypermatremic stimulation which suggests that *myo*-inositol

plays a major role as an osmolyte in the brain. *Myo*-inositol concentration was also reported to be increased significantly in the brain during chronic hypermatremia.

## V Mechanism of Action of Osmolytes

Increased concentration of salts in the cytosol may change the hydration sphere of macromolecules and thus affect their conformation or charge interactions. Osmotic adjustment is a process of active accumulation of compatible solutes under water deficit conditions. Osmolytes stabilize proteins and membranes against the denaturing effect of high concentration of salts and other harmful effects (Fig. 5). The physico-chemical basis of this protective effect involves the exclusion of osmo-protectant molecules from the hydration sphere of proteins. This creates a situation in which native proteins are thermodynamically favored because they present the least possible surface area to the water. In contrast salt enter the hydration sphere and interact directly with protein surfaces, favoring unfolding. Typically, compatible solutes are hydrophilic and they could substitute for water at the surface of proteins, protein complexes, or membranes. Hence, they may be considered to serve as osmoprotectants in this case (Shinozaki and Yamaguchi-Shinozaki 1999). However, there may be more than one function for a particular compatible solute, and different compatible solutes appear to have different functions (Shen et al. 1997). In this way compatible solutes are important for maintaining the conformation of macromolecule (Bohnert and Shen 1999).

An important feature of osmo-protectants is that they are not species-specific. This raises an idea that the skill of overproduction of osmolytes under stressed conditions from one stress tolerant plant can be transferred to another which inherently lacks ability to synthesize that particular osmolyte under stressed conditions. This makes engineering of plants for stress tolerance through osmolyte production an important and beneficial approach. In fact, engineering of such metabolic pathways for a number of compatible solutes show that transgenic plants display increased resistance to drought-stress, high salinity and cold stress (Chen and Murata 2002).

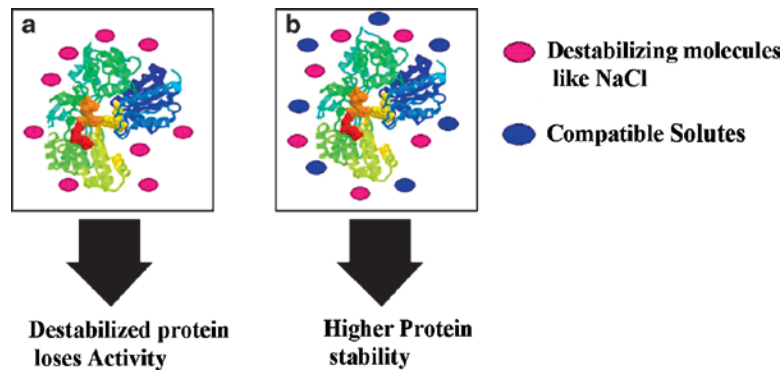

Fig. 5. Diagram illustrating the function of compatible solutes. (a) Lack of compatible solutes results in the preferential binding of destabilizing molecules like NaCl to the protein surface, leading to degradation; (b) Presence of compatible solutes preferentially excludes the binding of destabilizing molecules and stabilizes native protein conformation (Modified from Mundree et al. 2002) [See Color Plate 5, Fig. 10].

### A Osmolytes as Chaperones

The term “molecular chaperones” means the specific proteins that assist other proteins (nascent polypeptide chains) to achieve proper folding and thus restore their normal activity. There are many kinds of chaperones like the heat shock proteins. The main function of these chaperones is to help in the refolding of the proteins that are prone to coagulation or unfolding, under severe heat stress. The other important function of chaperones is to help in proper folding of the newly made proteins after they move out from the ribosome. Many also help in transport across membranes like in mitochondria and endoplasmic reticulum. In other words, chaperones lead to protein stability under stress conditions, be it proper folding of the proteins or by stabilization of the protein through cushioning of the stress (high salt and temperature).

Several kinds of osmolytes have been tested for their ability to stabilize proteins under stress conditions. They usually act by reducing the exposure of hydrophobic surface of the proteins. They also increase the stability of native proteins and assist in the proper refolding of unfolded polypeptides (due to stress or other natural conditions). As a result, osmolytes are often referred to as “chemical chaperones”.

A good example is the simple prokaryote, *Escherichia coli*. When *E. coli* is preadapted to high salinity, it is observed that the level of glycine betaine increases rapidly. Further studies showed that glycine betaine helps in preventing protein aggregation under temperature stress. The proteins that could not be protected under thermal stress in *E. coli* cells were observed to be well protected against aggregation in the pre-adapted cells. In vitro studies on the effects of four osmolytes, namely glycine betaine, glycerol, proline and trehalose illustrated that these osmolytes assisted in folding activities of either individual or combinations of chaperones like GroEL, DnaK and ClpB. These chaperones not only are involved in refolding of nascent polypeptides but also in refolding of thermally denatured proteins. Thus, during combined salt and heat stresses, cells can increase protein stability and chaperone-mediated disaggregation by adjusting the intracellular levels of different osmolytes (Diamant et al. 2001).

Additionally, in another study of *E. coli*, a conditional lysine mutant was developed where the growth of the mutant could be restored by the addition of lysine in the growth media. The most interesting observation was that the growth of the mutant could also be reinstated by the osmoprotectants like glycine betaine (GB) in the minimal medium.



The mutation was done in the *lysA* gene coding for diaminopimelate decarboxylase (DAPDC), enzyme catalyzing the conversion of meso-diaminopimelate to L-lysine. Glycine betaine was found to help in the proper folding of the mutant protein. It induced the transition of the inactive form to an active form of the enzyme and therefore displayed properties similar to those of chaperones (Bourot et al. 2000).

In addition to *E. coli*, in *Lysteria monocytogenes*, a food-borne pathogen that proliferates even at refrigeration temperatures and causes listeriosis, osmolytes like glycine betaine serve important roles. Glycine betaine was proven to provide cryo-protection to this organism. At 7°C, the organism had a significant increase in colony formation in the presence of glycine betaine in comparison to control conditions (Ko et al. 1994).

Thus, the role of glycine betaine in conferring protection to the proteins under the two extreme temperature stresses (heat and cold) may be due to its ability to maintain the proteins in their native conformation or by preventing the coagulation of proteins under such temperature stresses.

There are many other experiments that focus on the role of osmolytes as chaperones. For instance, ribonuclease A was checked for their stability in the presence of different osmolytes (glycine, sarcosine, N,N-dimethylglycine and betaine) under thermal stress. It was found that the presence of osmolytes (8.2 M sarcosine) led to the increase of thermal unfolding transition temperature ( $T_m$ ), up to 22°C and stabilization free energy increase of 7.2 kcal/mol at 65°C. On further calculations, it was found that such increase in  $T_m$  and free energy lead to almost 45,000-fold increase in the stability of the native form of the studied protein over that in the absence of sarcosine under similar conditions. Therefore, this is another method by which naturally occurring osmolytes mediate stabilization of proteins under thermal stress (Santoro et al. 1992).

In cystic fibrosis, cystic fibrosis trans-membrane conductance regulator protein is improperly folded due to certain mutations in the gene. As a result, this protein is retained in the endoplasmic reticulum and does not get transferred to plasma membrane where it normally functions.

Interestingly, it was observed that this unfolding of the protein could be corrected by osmolytes like glycerol and trimethylamine N-oxide, thus acting as chemical chaperones.

Proline is another familiar osmolyte that is well studied. It also acts as a thermo-protectant in *E. coli*. In *dnaK*-deficient mutant, elevated levels of proline were found to shield the cells at 42°C, in vivo. Not only this, presence of high concentration of proline reduced the protein aggregation in the mutant at 42°C as analyzed by two-dimensional gel electrophoresis. Like DnaK, proline was also observed to protect citrate synthase against thermo-denaturation and also helped in its renaturation after denaturing it with urea. Thus, proline could compensate for the mutation in such an important chaperone, truly following its role as a chemical chaperone (Chattopadhyay et al. 2004).

### B Osmolytes in Stabilization of Proteins

Osmolytes have also been known to be involved in the stabilization of proteins. In 1985, a work done by Arakawa and Timasheff showed studies with lysozyme interactions and stability with different osmolytes like L-proline, L-serine,  $\gamma$ -aminobutyric acid, sarcosine, taurine,  $\alpha$ -alanine,  $\beta$ -alanine, glycine, betaine and trimethylamine N-oxide. The results showed that these substances stabilize the protein structure against thermal denaturation and are excluded from the protein domain, leading to their direct binding to proteins. The mechanism that underlies the ability to stabilize is the preferential hydration as the strong polarity of these compounds enhances the cohesive force of water (Arakawa and Timasheff 1985). In another investigation by Shimizu and Boons (2004), the study showed that protein stability is enhanced by the addition of osmolytes like sugars and polyols. The reason and the mechanism of protein stability enhancement were found to be the preferential hydration parameter calculated based on Kirkwood-Buff theory. In this calculation, a statistical analysis was carried out and it was concluded that for osmolytes, hydration plays an important role (Shimizu and Smith 2004).

Osmolytes are often referred to as chemical chaperones due to their role in folding and

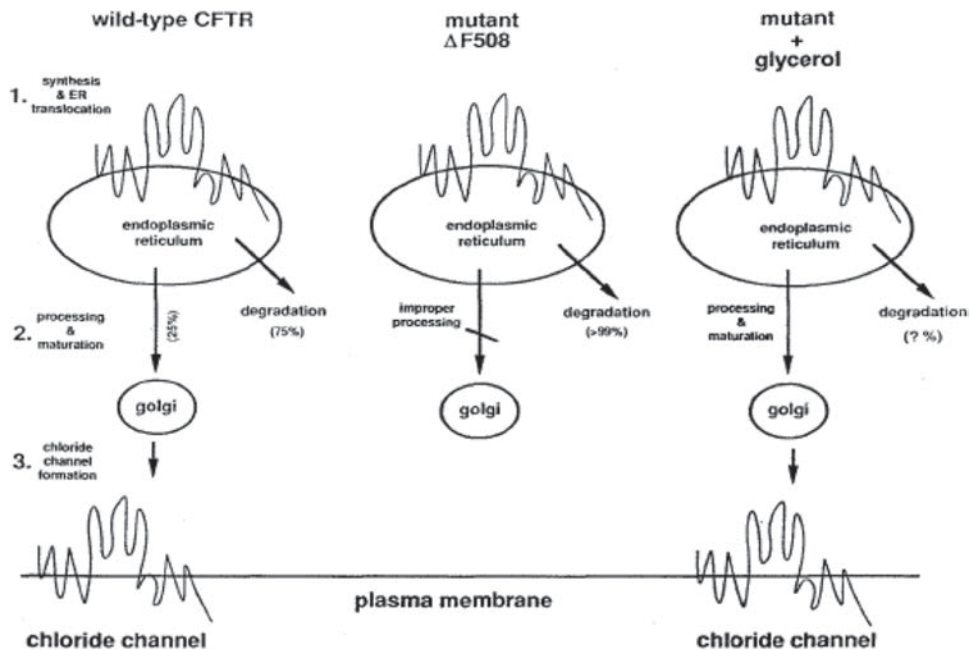

*Fig. 6.* Chemical chaperones, like glycerol, correct the processing defect associated with  $\Delta F508$  CFTR protein. Wild type CFTR: the wild-type cystic fibrosis transmembrane conductance regulator (CFTR) protein is synthesized and inserted into the membrane of the endoplasmic reticulum (ER). Although still not fully understood, only about 25% of the newly synthesized wild-type protein moves to the golgi complex on its way to the plasma membrane where it functions as a cAMP-dependent chloride channel. The remainder of the wild type protein (approx 75%) is degraded. Mutant  $\Delta F508$ : the newly synthesized  $\Delta F508$  CFTR mutant also is observed to be inserted into the membrane of the ER. In contrast to the wild-type protein, however, little or none of the protein is ever observed to move to the golgi complex as it is most likely being retained at the ER via the actions of the HSP73 and calnexin chaperones. Over a period of time, the mutant protein is degraded. These cells fail to exhibit cAMP-mediated chloride transport. Mutant + glycerol: incubation of cells expressing the  $\Delta F508$  CFTR protein in the presence of 0.5–1.25 M glycerol results in a portion of the mutant protein undergoing proper processing, including movement through golgi complex and localization to the plasma membrane. Like the situation with the wild type protein, a significant portion of the newly synthesized protein even in the presence of glycerol, likely is targeted to degradation. Cells expressing the mutant protein in the presence of glycerol now exhibit cAMP-stimulated chloride transport (Adapted from Welch and Brown 1996).

unfolding of proteins leading to their stability. The term “molecular chaperones” means the specific proteins that assist other proteins (nascent polypeptide chains) to achieve proper folding and thus, restore their normal activity. There are many kinds of chaperones like the heat shock proteins. The main function of these chaperones is to help in the refolding of the proteins that are prone to coagulation or unfolding, under severe heat stress. The other important function of chaperones is to help in proper folding of the newly made proteins after they move out from the ribosome. Many also help in transport across membranes like in mitochondria and endoplasmic reticulum. In other words, chaperone leads to protein stability under stress conditions, be it proper folding of

the proteins or cushioning of the stress (high salt and temperature) by stabilization of the protein (Fig. 6).

## VI Unique Osmolytes: Glucosylglycerol/ Diphosphoinositols

The cyanobacterium *Synechocystis* sp. strain PCC 6803 is able to acclimate to levels of salinity ranging from freshwater to twice the seawater concentrations of salt by accumulating the compatible solute glucosylglycerol (GG). Expression of the *ggs* gene coding for the key enzyme (glucosylglycerol-phosphate synthase) in GG synthesis is quite interesting. Under control conditions, the Ggs protein is stable, so that weak constitutive

Table 1. Key events involved in cooperation of transcriptional and biochemical control for salt-dependent regulation of GG synthesis in control, salt-shocked and salt-acclimated cells of *Synechocystis* (Marin et al. 2002; Ferjani et al. 2003)

Cells	Transcriptional control		Biochemical control		GG synthesis
	<i>ggpS</i> mRNA level	GgpS protein level	Ion concentration	GgpS activity	
Control	Weak, constitutive expression, $\sigma^F$ independent	Constitutive level, very stable protein	Low	Completely inactive	Switched off
Salt shocked	Stress proportional, $\sigma^F$ dependent transient increase, transient mRNA stabilization	Linear protein accumulation, up to tenfold increase	Transiently high	Completely active	Linear accumulation, maximal rate
Salt acclimated	Salt proportional, $\sigma^F$ dependent increase	Salt proportional, increased level	Salt proportional, weakly increased	Partially active	Salt proportional

transcription of the *ggpS* gene resulted in significant protein content. However, the enzyme activity was biochemically switched off and no GG was detectable. After a salt shock, an immediate increase in mRNA content proportional to the salt content occurred, while the GgpS protein and GG contents rose in a linear manner. Furthermore, the stability of the *ggpS* mRNA increased transiently. In salt-acclimated cells expression of the *ggpS* gene, the GgpS protein content, and the amount of accumulated GG depended linearly on the external salt concentration. The 5' end of the *ggpS* transcript revealed a long UTR and a putative typical cyanobacterial promoter, which did not show any obvious salt-regulatory element. Fascinatingly, the alternative  $\sigma$  factor  $\sigma^F$  was found to be involved in salt-dependent regulation of *ggpS*, since in a  $\sigma^F$  mutant induction of this gene was strongly reduced. Thus of GgpS activity is regulated in both product activity and expression level in *Synechocystis* sp. strain PCC 6803 and that too by stress (Marin et al. 2002). The interaction of the two regulatory levels is shown in Table 1.

## VII Transgenics with Compatible Solutes for Salinity Stress Tolerance

One approach to improve stress tolerance in crops is to transfer the candidate genes responsible for

the adaptive traits from the tolerant organism to the sensitive crop plants. It has been established that many of the osmo-protectants enhance stress tolerance of the plants when expressed as transgene products (Bohnert and Jensen 1996; Zhu 2001).

However, this process has not been much successful using conventional means like plant breeding because such techniques are highly time consuming and less efficient. This is for the reason that the traits are poorly described genetically and also because of the transfer of unwanted genes during conventional crossing procedures. However, genetic transformation technology enables us to achieve gene transfer in a precise and, to some extent, predictable manner. There lie many instances where such gene transfer in plants has led to considerable stress tolerance.

Because compatible solutes are non-toxic, the ability to inter-change these compounds in between different species as a strategy to develop stress tolerant crops has held much interest. Table 2 shows that genetically engineered overproduction of compatible solutes in transgenic plants like *Arabidopsis*, rice, wheat and *Brassica* achieve an enhanced stress tolerance as measured by germination, seedling growth, survival, recovery, Photosystem II yield and seed production. These aspects have also been covered in details under Chapter 19.

Table 2. Salt-stress tolerance of transgenic plants over-producing compatible osmolytes

Gene and source	Transgenic plants	Stress tolerant traits	Reference
<i>Mannitol</i>			
<i>E. coli mt1D</i> (mannitol-1-phosphate dehydrogenase)	Tobacco	Fresh weight, plant height and flowering under salinity stress	Tarczynski et al. (1993)
<i>E. coli mt1D</i>	<i>Arabidopsis</i>	Germination at 400 mM NaCl	Thomas et al. (1995)
<i>E. coli mt1D</i>	Tobacco	Salt-stress tolerance; mannitol; contributed only to 30–40% of the osmotic adjustment	Karakas et al. (1997)
<i>E. coli mt1D</i>	Wheat ( <i>Triticum aestivum</i> L.)	Only 8% biomass reduction when compared to 56% reduction in control plants in 150 mM NaCl stress	Abebe et al. (2003)
<i>D-ononitol</i>			
<i>IMT1</i> (myo-inositol <i>O</i> -methyl transferase) of common ice plant	Tobacco	Drought and salinity stress	Sheveleva et al. (1997)
<i>Sorbitol</i>			
<i>Stpd1</i> (sorbitol-6-phosphate dehydrogenase) of apple driven by CaMV 35S promoter	Japanese persimmon	Tolerance in Fv/Fm ratio under NaCl stress	Gao et al. (2001)
<i>Glycine betaine</i>			
<i>Arthrobacter globiformis Coda</i> (choline oxidase)	<i>Arabidopsis</i>	Germination at 300 mM NaCl; seedling growth at 200 mM NaCl; retention of PSII activity at 400 mM NaCl	Hayashi et al. (1997)
<i>A. globiformis Coda</i> targeted to the chloroplasts or cytosol	Rice	Faster recovery after 150 mM NaCl stress	Sakamoto et al. (1998); Mohanty et al. (2002)
<i>A. globiformis Coda</i>	<i>Brassica juncea</i> L.	Germination in 100–150 mM NaCl; seedling growth in 200 mM NaCl	Prasad et al. (2000)
<i>E. coli</i> choline dehydrogenase ( <i>betA</i> ) and betaine aldehyde dehydrogenase ( <i>betB</i> ) genes	Tobacco	Biomass production of greenhouse grown plants under salt stress; faster recovery from photo	Holmstrom et al. (2000)
<i>Atriplex hortensis</i> betaine aldehyde dehydrogenase ( <i>BADH</i> ) gene under maize ubiquitin promoter	Wheat ( <i>Triticum aestivum</i> L.)	Seedling growth in 0.7% (120 mM) NaCl	Guo et al. (2001)
Barley peroxisomal <i>BADH</i> gene	Rice	Stability in chlorophyll fluorescence under 100 mM NaCl stress; accumulates less Na and Cl <sup>-</sup> but maintained K <sup>+</sup> uptake	Kishitani et al. (2000)
<i>Proline</i>			
<i>Vigna aconitifolia</i> L. <i>P5CS</i> pyrroline-5-carboxylate synthetase gene	Tobacco	Root growth; flower development	Kishor et al. (1995)
<i>Vigna aconitifolia</i> L. <i>P5CS</i> gene under barley HVA22 promoter	Rice	Faster recovery after a short period of salt stress	Zhu et al. (1998)
Mutated gene of <i>Vigna aconitifolia</i> L. <i>P5CS</i> which encode <i>P5CS</i> enzyme that lacks end product (proline)	Tobacco	Improved seedlings tolerance and low free radical levels at 200 mM NaCl inhibition	Hong et al. (2000)
Antisense proline dehydrogenase gene	<i>Arabidopsis</i>	Tolerant to high salinity (600 mM NaCl); constitutive freezing tolerance (-7°C)	Nanjo et al. (1999)
<i>Trehalose</i>			
<i>E. coli otsA</i> (trehalose-6-phosphate synthase) and <i>otsB</i> (trehalose-6-phosphate phosphatase) bi-functional fusion gene ( <i>TPSP</i> ) under the control of ABA responsive promoter or Rubisco small subunit ( <i>rbcS</i> ) promoter	Rice	Root and shoot growth at 4 wk of 100 mM NaCl stress; survival under prolonged salt stress; maintenance of high K <sup>+</sup> /Na <sup>+</sup> ratio; Low Na accumulation in the shoot; maintained high PSII activity and soluble sugar levels	Garg et al. (2002)
<i>E. coli TPSP</i> under maize ubiquitin promoter	Rice	Better seedling growth and PSII yield under salt, drought and cold stresses	Jang et al. (2003)



## VIII Conclusions

The inherent capability of organisms to choose a particular metabolite from osmotic adjustment during abiotic stress resides primarily on the individuals metabolic make-up. This phenomenon is exemplified in the variety of osmolytes known to do a common biological function of osmo-protection by way of stabilization of macromolecular structure or as an osmoticum. While synthesis of such compounds is generally accompanied by extension of normal metabolic pathways, which are presumably induced during stress (such as proline, glycine betaine, pinitol and trehalose), identification of such a role for the ubiquitous inositol itself, produced even under control conditions is a more recent finding. Additionally, many a times the amount required for osmotic adjustment under increased salinity, drought or water deficit conditions falls far below the required amount raising the possibility of an alternate role for such compounds in conferring stress tolerance. Linking for such a role has been provided by analysis of the trehalose and inositol overproducing transgenic systems. Future research in this direction would become an important aspect of osmolyte mediated abiotic stress amelioration process.

## References

- Abe S, Kaneda T (1973) Studies on the effect of marine products on cholesterol metabolism in rats: VIII. The isolation of hypocholesterolemic substance from green laver. *Bull Jpn Soc Sci Fish* 39:383–389
- Abebe T, Guenzi AC, Martin B, Cushman JC (2003) Tolerance of mannitol accumulating transgenic wheat to water stress and salinity. *Plant Physiol* 131:1748–1755
- Abu-Abied M, Holland D (1994) Two newly isolated genes from citrus exhibit different pattern of diurnal expression and light response. *Plant Mol Biol* 26:165–173
- Adhikari J, Majumder AL, Bhaduri TJ, Dasgupta S, Majumder AL (1987) Chloroplast as a locale of L-myo-inositol 1-phosphate synthase. *Plant Physiol* 85:611–614
- Andresen PA, Kaasen I, Styrvoid OB, Boulnois G, Strøm AR (1988) Molecular cloning, physical mapping and expression of the bet genes governing the osmoregulatory choline-glycine betaine pathway of *Escherichia coli*. *J Gen Microbiol* 134:1737–1746
- Arakawa T, Timasheff SN (1985) The stabilization of proteins by osmolytes. *Biophys J* 47:411–414
- Argüelles JC (2000) Physiological roles of trehalose in bacteria and yeasts: a comparative analysis. *Arch Microbiol* 174:217–224
- Armengauda P, Thieryc L, Buhota N, Marchb GG, Savoure A (2004) Transcriptional regulation of proline biosynthesis in *Medicago truncatula* reveals developmental and environmental specific features. *Physiol Plant* 120:442–450
- Bayles DO, Wilkinson BJ (2000) Osmoprotectants and cryoprotectants for *Listeria monocytogenes*. *Lett Appl Microbiol* 30:23–27
- Bohnert HJ, Jensen RG (1996) Strategies for engineering water-stress tolerance in plants. *Trends Biotechnol* 14:89–97
- Bohnert HJ, Shen B (1999) Transformation and compatible solutes. *Sci Hort* 78:237–260
- Bourot S, Sire O, Trautwetter A, Touze T, Wu LF, Blanco C, Bernard T (2000) Glycine betaine-assisted protein folding in a lysA mutant of *Escherichia coli*. *J Biol Chem* 275:1050–1056
- Burg MB (1996) Coordinate regulation of organic osmolytes in renal cells. *Kidney Int* 49:1684–1685
- Chattopadhyay MK, Kern R, Mistou M, Dandekar AM, Uratsu SL, Richarme G (2004) The chemical chaperone proline relieves the thermosensitivity of a dnaK deletion mutant at 42°C. *J Bacteriol* 186:8149–8152
- Chen TH, Murata N (2002) Enhancement of tolerance of abiotic stress by metabolic engineering of betaines and other compatible solutes. *Curr Opin Plant Biol* 5:250–257
- Crowe JH, Hoekstra FA, Crowe LM (1992) Anhydrobiosis. *Annu Rev Physiol* 54:579–599
- Das-Chatterjee A, Goswami L, Maitra S, Dastidar KG, Ray S, Majumder AL (2006) Introgression of a novel salt-tolerant L-myo-inositol 1-phosphate synthase from *Porteresia coarctata* (Roxb.) Tateoka (PcINO1) confers salt tolerance to evolutionary diverse organisms. *FEBS Lett* 580:3980–3988
- Delauney AJ, Verma DPS (1993) Proline biosynthesis and osmoregulation in plants. *Plant J* 4:215–223
- Diamant S, Eliahu N, Rosenthal D, Goloubinoff P (2001) Chemical chaperones regulate molecular chaperones in vitro and in cells under combined salt and heat stresses. *J Biol Chem* 276:39586–39591
- Donahue TF, Henry SA (1981) Myo-Inositol-1-phosphate synthase: characteristics of the enzyme and identification of its structural gene in yeast. *J Biol Chem* 256:7077–7085
- Ferjani A, Mustardy L, Sulpice R, Marin K, Suzuki I, Hagemann M, Murata N (2003) Glucosylglycerol, a compatible solute, sustains cell division under salt stress. *Plant Physiol* 131:1628–1637
- Gao M, Tao R, Miura K, Dandekar AM, Sugiura A (2001) Transformation of Japanese persimmon (*Diospyros kaki* Thunb.) with apple cDNA encoding NADP-dependent sorbitol-6-phosphate dehydrogenase. *Plant Sci* 160:837–845

- Garcia-Perez A, Burg MB (1991) Role of organic osmolytes in adaptation of renal cells to high osmolality. *J Membr Biol* 119:1–13
- Garg AK, Kim JK, Owens TG, Ranwala AP, Choi YD, Kochian LV, Wu RJ (2002) Trehalose accumulation in rice plants confers high tolerance levels to different abiotic stresses. *Proc Natl Acad Sci USA* 99: 15898–15903
- Ghosh Dastidar K, Maitra S, Goswami L, Roy D, Das KP, Majumder AL (2006). An insight into the molecular basis of salt tolerance of L-myo-inositol 1-P synthase (PcINO1) from *Porteresia coarctata* (Roxb.) Tateoka, a halophytic wild rice. *Plant Physiol* 140:1279–1296
- Greenway H, Munns R (1980) Mechanisms of salt tolerance in non-halophytes. *Annu Rev Plant Physiol* 31:149–190
- Grennan AK (2007) The role of trehalose biosynthesis in plants. *Plant Physiol* 144:3–5
- Guo Y, Halfter U, Ishitani M, Zhu JK (2001) Molecular characterization of functional domains in the protein kinase SOS2 that is required for plant salt tolerance. *Plant Cell* 13:1383–1400
- Hanson AD, Burnet M (1994) Evolution and metabolic engineering of osmoprotectant accumulation in higher plants. In: Cherry JH (ed) *Cell biology: biochemical and cellular mechanisms of stress tolerance in plants*. NATO ASI Series H. Springer, Berlin, pp 291–302
- Hanson AD, Gage DA (1991) Identification and determination by fast atom bombardment mass spectrometry of the compatible solute choline-*o*-sulphate in *Limonium* sp. and other halophytes. *Aust J Plant Physiol* 18:317–327
- Hare PD, Cress WA (1997) Metabolic implications of stress induced proline accumulation in plants. *Plant Growth Regul* 21:79–102
- Hare PD, Cress WA, Staden JV (1998) Dissecting the roles of osmolyte accumulation during stress. *Plant Cell Environ* 21:535–553
- Hartmann A, Prabhu SR, Galinski EA (1991) Osmotolerance of diazotrophic rhizosphere bacteria. *Plant Soil* 137:105–109
- Hasegawa PM, Bressan RA, Zhu JK, Bohnert HJ (2000) Plant cellular and molecular responses to high salinity. *Annu Rev Plant Physiol Plant Mol Biol* 51:463–499
- Hayashi H, Alia Mustardy L, Deshniem P, Ida M, Murata N (1997) Transformation of *Arabidopsis thaliana* with the *codA* gene for choline oxidase; accumulation of glycinebetaine and enhanced tolerance to salt and cold stress. *Plant J* 12:133–142
- Holmstrom KO, Somersalo S, Mandal A, Palva TE, Welin B (2000) Improved tolerance to salinity and low temperature in transgenic tobacco producing glycinebetaine. *J Exp Bot* 51:177–185
- Hong Z, Lakkineni K, Zhang K, Verma DPS (2000) Removal of feedback inhibition of D1-pyrroline-5-carboxylate synthetase results in increased proline accumulation and protection of plants from osmotic stress. *Plant Physiol* 122:1129–1136
- Ikuta S, Imamura S, Misaki H, Horiuti Y (1977) Purification and characterization of choline oxidase from *Arthrobacter globiformis*. *J Biochem* 82:1741–1749
- Ilg T (2002) Generation of myo-inositol-auxotrophic *Leishmania mexicana* mutants by targeted replacement of the myo-inositol-1-phosphate synthase gene. *Mol Biochem Parasitol* 120:151–156
- Imhoff V, Bourdu R (1973) Formation d'inositol par les chloroplastes de pois. *Phytochemistry* 12:331–336
- Ishitani M, Majumder AL, Bornhouser A, Michalowski CB, Jensen RG, Bohnert HJ (1996) Coordinate transcriptional induction of myo-inositol metabolism during environmental stress. *Plant J* 9:537–548
- Jang IC, Oh SJ, Seo JS, Choi WB, Song SI, Kim CH, Kim YS, Seo HS, Choi YD, Nahm BH, Kim JK (2003) Expression of a bifunctional fusion of the *Escherichia coli* genes for trehalose-6-phosphate synthase and trehalose-6-phosphate phosphatase in transgenic rice plants increases trehalose accumulation and abiotic stress tolerance without stunting growth. *Plant Physiol* 131:516–524
- Karakas B, Ozias-Akins P, Stushnoff C, Suefferheld M, Rieger M (1997) Salinity and drought tolerance in mannitol-accumulating transgenic tobacco. *Plant Cell Environ* 20:609–616
- Kayingo G, Kilian SG, Prior BA (2001) Conservation and release of osmolytes by yeasts during hypo-osmotic stress. *Arch Microbiol* 177:29–35
- Kishitani S, Takanami T, Suzuki M, Oikawa M, Yokoi S, Ishitani M, Alvarez-Nakase AM, Takabe TT (2000) Compatibility of glycinebetaine in rice plants: evaluation using transgenic rice plants with a gene for peroxisomal betaine aldehyde dehydrogenase from barley. *Plant Cell Environ* 23:107–114
- Kishor KPB, Hong Z, Miao GH, Hu CAA, Verma DPS (1995) Over-expression of D1-pyrroline-5-carboxylate synthetase increases proline production and confers osmotolerance in transgenic plants. *Plant Physiol* 108: 1387–1394
- Klig LS, Zobel PA, Devry CG, Losberger C (1994) Yeast sequencing reports: comparison of INO1 gene sequences and products in *Candida albicans* and *Saccharomyces cerevisiae*. *Yeast* 10:789–800
- Ko R, Smith LT, Smith GM (1994) Glycine betaine confers enhanced osmotolerance and cryotolerance on *Listeria monocytogenes*. *J Bacteriol* 176:426–431
- Kotchoni SO, Bartels D (2003) Water stress induces the up-regulation of a specific set of genes in plants: aldehyde dehydrogenases as an example. *Bulg J Plant Physiol (special issue)*:37–51
- Loewus FA, Loewus MW (1983) Myo-inositol: its biosynthesis and metabolism. *Annu Rev Plant Physiol* 34: 137–161
- Louis P, Galinski EA (1997) Characterization of genes for the biosynthesis of compatible solute ectoine from *Marinococcus halophilus* and osmoregulated expression in *Escherichia coli*. *Microbiology* 143:1141–1149

- Majumder AL, Johnson MD, Henry SA (1997) 1L-*myo*-inositol-1-phosphate synthase. *Biochim Biophys Acta* 1348:245–256
- Majumder AL, Chatterjee A, GhoshDastidar K, Majee M (2003) Diversification and evolution of L-*myo*-Inositol 1-phosphate synthase. *FEBS Lett* 553:3–10
- Majee M, Maitra S, Ghosh Dastidar K, Pattnaik S, Chatterjee A, Hait N, Das KP, Majumder AL (2004) A novel salt-tolerant L-*myo*-inositol 1-phosphate synthase from *Porteresia coarctata* Tateoka, a halophytic wild rice: Molecular cloning, bacterial overexpression, characterization and functional introgression into tobacco conferring salt-tolerance phenotype. *J Biol Chem* 279:28539–28552
- Marin K, Huckauf J, Fulda S, Hagemann M (2002) Salt-dependent expression of glucosylglycerol-phosphate synthase, involved in osmolyte synthesis in the cyanobacterium *Synechocystis* sp. strain PCC 6803. *J Bacteriol* 184:2870–2877
- Matsell DG, Bennett T, Han X, Budreau AM, Chesney RW (1997) Regulation of the taurine transporter gene in the S3 segment of the proximal tubule. *Kidney Int* 52:748–754
- Mohanty A, Kathuria H, Ferjani A, Sakamoto A, Mohanty P, Murata N, Tyagi AK (2002) Transgenics of an elite indica rice variety Pusa Basmati 1 harbouring the *codA* gene are highly tolerant to salt stress. *Theor Appl Genet* 106:51–57
- Molina Y, Ramos SE, Douglass T, Klig LS (1999) Inositol synthesis and catabolism in *Cryptococcus neoformans*. *Yeast* 15:1657–1667
- Mundree GS, Baker B, Mowla S, Peters S, Marais S, Willigen CV, Govender K, Maredza A, Muyanga S, Farrant JM, Thomson JA (2002) Physiological and molecular insights into drought tolerance. *Afr J Biotechnol* 1: 28–38
- Nakayama H, Yoshida K, Ono H, Murooka Y, Shinmyo A (2000) Ectoine, the compatible solute of *Halomonas elongata*, confers hyperosmotic tolerance in cultured tobacco cells. *Plant Physiol* 122:1239–1247
- Nanjo T, Kobayashia M, Yoshiba Y, Kakubaric Y, Shinozaki K, Shinozaki K (1999) Antisense suppression of proline degradation improves tolerance to freezing and salinity in *Arabidopsis thaliana*. *FEBS Lett* 461:205–210
- Nelson DE, Koukoumanos M, Bohnert HJ (1999) Myo-inositol-dependent sodium uptake in the ice plant. *Plant Physiol* 119:165–172
- Nelson DE, Rammesmayr G, Bohnert HJ (1998) Regulation of cell specific inositol metabolism and transport in plant salinity tolerance. *Plant Cell* 10:753–764
- Ono H, Sawada K, Khunajakr N, Tao T, Yamamoto M, Hiramoto M, Shinmyo A, Takano M, Murooka Y (1999) Characterization of biosynthetic enzymes for ectoine as a compatible solute in a moderately halophilic eubacterium, *Halomonas elongata*. *J Bacteriol* 181:91–99
- Paul MJ, Cockburn W (1989) Pinitol, a compatible solute in *Mesembryanthemum crystallinum* L. *J Exp Bot* 40: 1093–1098
- Prasad KV, Sharmila P, Pardha Saradhi P (2000) Enhanced tolerance of transgenic Brassica juncea to choline confirms successful expression of the bacterial *codA* gene. *Plant Sci* 159:233–242
- Rathinasabapathi B, Burnet M, Russell BL, Gage DA, Liao PC, Nye GJ, Scott P, Golbeck JH, Hanson AD (1997) Choline monooxygenase, an unusual iron-sulfur enzyme catalyzing the first step of glycine betaine synthesis in plants: prosthetic group characterization and cDNA cloning. *Proc Natl Acad Sci USA* 94:3454–3458
- Rathinasabapathi B, McCue KF, Gage DA, Hanson AD (1994) Metabolic engineering of glycine betaine synthesis: plant betaine aldehyde dehydrogenases lacking typical transit peptides are targeted to tobacco chloroplasts where they confer betaine aldehyde resistance. *Planta* 193:155–162
- Rathinasabapathi B, Sigua C, Ho J, Gage DA (2000) Osmoprotectant  $\beta$ -alanine betaine synthesis in the plumbaginaceae: S-adenosyl-L-methionine dependent N-methylation of  $\beta$ -alanine to its betaine is via N-methyl and N, N-dimethyl  $\beta$ -alanines. *Physiol Plant* 109: 225–231
- Raychaudhuri A, Majumder AL (1996) Salinity-induced enhancement of L-*myo*-inositol 1-phosphate synthase in rice (*Oryza sativa* L.). *Plant Cell Environ* 19: 1437–1442
- Rhodes D, Samaras Y (1994) Genetic control of osmoregulation in plants. In: Strange SK (ed) Cellular and molecular physiology of cell volume regulation. CRC Press, Boca Raton, FL, pp 347–361
- Richard H, Sterns MD, Stephen M (2006) Brain volume regulation in response to hypo-osmolality and its correction – hyponatremia: new understanding, new therapy. *Am J Med* 119:S12–S16
- Sakamoto A, Alia A, Murata N, Murata A (1998) Metabolic engineering of rice leading to biosynthesis of glycinebetaine and tolerance to salt and cold. *Plant Mol Biol* 38:1011–1019
- Santoro M, Liu Y, Khan S, Hou L, Bolen DW (1992) Increased thermal stability of proteins in the presence of naturally occurring osmolytes. *Biochemistry* 31: 5278–5283
- Shen B, Jensen RG, Bohnert HJ (1997) Increased resistance to oxidative stress in transgenic plants by targeting mannitol biosynthesis to chloroplasts. *Plant Physiol* 113:1177–1183
- Sheveleva E, Chmara W, Bohnert HJ, Jensen RG (1997) Increased salt and drought tolerance by D-ononitol production in transgenic *Nicotiana tabacum* L. *Plant Physiol* 115:1211–1219
- Shimizu S, Boon CL (2004) The Kirkwood-Buff theory and the effect of cosolvents on biochemical reactions. *J Chem Phys* 121:9147–9155
- Shimizu S, Smith DJ (2004) Preferential hydration and the exclusion of cosolvents from protein surfaces. *J Chem Phys* 121:1124–1154

- Shinozaki K, Yamaguchi-Shinozaki K (eds) (1999) Molecular responses to cold, drought, heat and salt stress in higher plants. R.G. Landes Company, Austin, TX, pp 169
- Singh TN, Aspinall D, Paleg LG (1972) Proline accumulation and varietal adaptability to drought in barley: a potential metabolic measure of drought resistance. *Nature* 236:188–190
- Smart CC, Fleming AJ (1993) A plant gene with homology to D-*myo*-inositol-phosphate synthase is rapidly and specially upregulated during an abscisic acid induced response in *Spirodela polyrrhiza*. *Plant J* 4:279–293
- Smart CC, Flores S (1997) Overexpression of D-*myo* inositol-3-phosphate synthase leads to elevated levels of *myo*-inositol in *Arabidopsis*. *Plant Mol Biol* 33:811–820
- Smirnoff N, Cumbes QJ (1989) Hydroxyl radical scavenging activity of compatible solutes. *Phytochemistry* 28:1057–1060
- Taji T, Ohsumi C, Iuchi S, Seki M, Kasuga M, Kobayashi M, Yamaguchi-Shinozaki K, Shinozaki K (2002) Important roles of drought- and cold-inducible genes for galactinol synthase in stress tolerance in *Arabidopsis thaliana*. *Plant J* 29:417–426
- Tarczynski MC, Jensen RG, Bohnert HJ (1993) Stress protection of transgenic tobacco by production of the osmolyte mannitol. *Science* 259:508–510
- Thomas JC, Sepahi M, Arendall B, Bohnert HJ (1995) Enhancement of seed germination in high salinity by engineering mannitol expression in *Arabidopsis thaliana*. *Plant Cell Environ* 18:801–806
- Timmerman BN, Steelink C, Loewus FA (eds) (1983) Phytochemical adaptations to stress, *Recent Adv Phytochemistry*, p 18. Plenum Press, New York
- Uchida S, Nakanishi T, Kwon HM, Preston AS, Handler JS (1991) Taurine behaves as an osmolyte in Madin-Darby canine kidney cells: protection by polarized, regulated transport of taurine. *J Clin Invest* 88:656–662
- Warskulat U, Reinen A, Grether-Beck S, Krutmann J, Haussinger D (2004) The osmolyte strategy of normal human keratinocytes in maintaining cell homeostasis. *J Invest Dermatol* 123:516–521
- Welch WJ, Brown CR (1996) Influence of molecular and chemical chaperones on protein folding. *Cell Stress Chaperones* 1:109–115
- Welsh DT, Herbert RA (1999) Osmotically induced intracellular trehalose, but not glycine betaine accumulation promotes desiccation tolerance in *Escherichia coli*. *FEMS Microbiol Lett* 174:57–63
- Weretilnyk EA, Smith DD, Wilch GA, Summers PS (1995) Enzymes of choline synthesis in spinach: response of phosphobase N-methyltransferase activities to light and salinity. *Plant Physiol* 109:1085–1091
- Yamauchi A, Sugiura T, Ito T, Miyai A, Horio M, Imai E, Kamada T (1996) Na<sup>+</sup>/Myo-inositol transport is regulated by basolateral tonicity in Madin-Darby canine kidney cells. *J Clin Invest* 97:263–267
- Yoshihara Y, Kiyosue T, Nakashima K, Yamaguchi-Shinozaki K, Shinozaki K (1997) Regulation of levels of proline as an osmolyte in plants under water stress. *Plant Cell Physiol* 38:1095–1102
- Zhu B, Su J, Chang M, Verma DPS, Fan YL, Wu R (1998) Overexpression of a  $\Delta 1$ -pyrroline-5-carboxylate synthetase gene and analysis of tolerance to water- and salt-stress in transgenic rice. *Plant Sci* 139:41–48
- Zhu JK (2001) Plant salt tolerance. *Trends Plant Sci* 6:66–71



# Chapter 17

## Programmed Cell Death in Plants

Avijit Das

*Division of Biochemistry, Central Rice Research Institute,  
Cuttack 753 006, Orissa, India*

Maki Kawai-Yamada

*Institute of Molecular and Cellular Biosciences, University of Tokyo,  
1-1-1, Yayoi, Bunkyo-ku, Tokyo 113-0032, Japan  
Core Research for Evolutional Science and Technology (CREST) Project,  
Japan Science and Technology Agency (JST), Office of Basic Research, 5, Sanbancho,  
Chiyoda-ku, Tokyo 102-0075, Japan  
Department of Environmental Science and Technology, Saitama University,  
255 Shimo-Okubo, Sakura-ku, Saitama 338-8570, Japan*

Hirofumi Uchimiya\*

*Institute of Molecular and Cellular Biosciences, University of Tokyo,  
1-1-1, Yayoi, Bunkyo-ku, Tokyo 113-0032, Japan  
Iwate Biotechnology Center, Kitakami, Iwate 024-0003, Japan*

Summary .....	372
I Introduction .....	372
II Anatomy of Cell Death .....	373
III Biochemistry of Cell Death .....	374
IV Role of Vacuole .....	375
V Role of Mitochondrion .....	375
VI Role of Chloroplast .....	376
VII Signals in Cell Death .....	377
VIII Cell Death Regulator .....	378
IX Conclusions .....	379
References .....	379

---

\* Author for Correspondence, e-mail: [uchimiya@iam.u-tokyo.ac.jp](mailto:uchimiya@iam.u-tokyo.ac.jp)

## Summary

Throughout the life cycle of plants, programmed cell death (PCD) is involved in a wide range of developmental processes and responses against abiotic or biotic stresses. PCD is an active form of cellular suicide controlled by a network of genes. Such phenomenon is associated with recovery of cellular compounds and sustaining plant life. Basic morphological and biochemical features of PCD are believed to be conserved in both plants and animals. Nevertheless, recent studies demonstrate an involvement of organelles such as vacuole and chloroplast in plant cell death regulation, indicating that plants evolved own cell death machinery. Reactive oxygen species (ROS) generated by biotic and abiotic stresses act as a signal that induces plant PCD. This article describes some of the fundamental characteristics of plant PCD and raises points that may lead to a better understanding and novel strategies for plant molecular breeding.

**Keywords:** Aerenchyma • apoptosis • mitochondria • oxidative stress • programmed cell death • reactive oxygen species

## I Introduction

In multicellular organisms, specific cells commit suicide to achieve and maintain homeostasis by specifically ordered metabolic changes during normal development, environmental stress, or pathogen attack. This functionally conserved and gene-directed cell death process is known as programmed cell death (PCD). The phenomenon depends on active participation of the dying cells, and could be regulated by genetically controlled, well-orchestrated cell suicide machinery. The common process in such instances comprise one or more phenotypes such as cytoplasmic shrinkage, membrane blebbing, loss of cell-to-cell contact, DNA fragmentation and disassembly of the nuclei (Lam et al. 2001; Lam 2004). Today, ample evidence can be presented to support that cell death during plant development and environmental challenges involves PCD (Fig. 1).

PCD occurs in numerous vegetative as well as reproductive phases of plant development, including senescence of leaves (Gan and Amasino 1997), development of tracheary elements (Zhang et al. 2002), timely death of petals after fertilization (Havel and Durzan 1996), post-embryonic decay of aleurone layers (Wang et al. 1996b), root cap development (Moller and McPherson 1998), somatic as well as zygotic embryogenesis (Giuliani et al. 2002) and sex determination (De Long et al. 1993). A number of abiotic stresses such as salinity, extreme temperatures, excess light and UV radiation lead to production of ROS (Dhariwal et al. 1998). Reactive oxygen species (ROS) generated by biotic and abiotic stimuli act as molecules that function at the early stage of signal transduction, stress adaptation and PCD. Signaling responses of ROS include activation of MAPK related to hypersensitive response – HR (Hancock et al. 2002). Exogenously supplied ROS, such as H<sub>2</sub>O<sub>2</sub>, also induces cell death in soybean (Levine et al. 1994), tobacco (Houot et al. 2001), and *Arabidopsis* (Tiwari et al. 2002), which includes cell shrinkage, DNA fragmentation and chromatin condensation.

The cell death process can be divided into three phases: an induction phase, the nature of which depends on the specific death-inducing signals; an effector phase, during which the cells commit to die; and a degradation phase, where the biochemical and morphological features of cell collapse can be observed (Martins and Earnshaw 1997).

---

*Abbreviations:* CaM – calmodulin; CERK – ceramide kinase; ER – endoplasmic reticulum; HR – hypersensitive response; LRR – leucine-rich repeat; MAPKs – mitogen activated protein kinases; MTP – mitochondrial-permeability transition pore; NBS – nucleotide binding site; PCD – programmed cell death; PK – protein kinase; PS – phosphatidyl serine; ROS – reactive oxygen species; SERCA – sarco endoplasmic reticulum Ca<sup>2+</sup> ATPase; TM – transmembrane-domain; TMV – tobacco mosaic virus; TNF – tumour necrosis factor; VPE – vacuolar processing enzyme

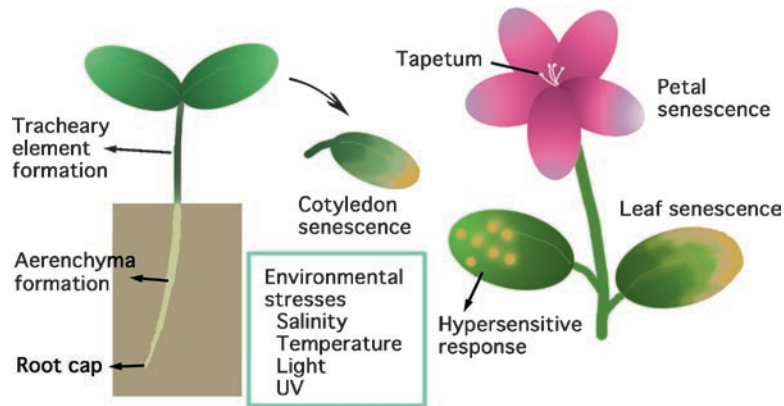

Fig. 1. PCD occurs in plant life cycle. PCD is involved in many phases through vegetative and reproductive development and response to environmental stresses [See Color Plate 6, Fig. 12].

In plants, some PCD resembles either a common form seen in animals called apoptosis or it resembles a morphologically distinct form of cell death (Pennel and Lamb 1997). However, distinctive characteristics of plant cells including the existence of a cell wall imply that there are dissimilarities in the execution of PCD. The cell wall precludes phagocytosis, establishing a different mechanism for corpse management. Similarly, the vacuole can be transformed into a hydrolytic compartment with hydrolases and toxin profiles (Paris et al. 1996) that degrade the components of dying cell after collapse of the vacuole.

## II Anatomy of Cell Death

Plant cells are characterized by the presence of cell wall. The cell wall may or may not be degraded along with the protoplast, depending on the type of PCD (Jones 2001). During tracheary element differentiation, the primary wall and a rigid secondary wall are required for cell function and are not hydrolyzed, except for portion of the primary wall between the adjacent tracheary elements that is degraded to form perforations (Nakashima et al. 2000). In most other forms of developmental PCD, collapsed primary cell walls are left behind, whereas nutrients from dismantled protoplast are recycled (He and Kermode 2003). When the HR is induced by pathogen invasion, the protoplast dies, leaving collapsed or crushed primary cell

wall behind (Mittler and Lam 1997). Lysogenic aerenchyma formation involves death and often complete lysis of cells, with the disappearance of all cell components, including the cytoplasm and cell walls (Kozela and Regan 2003). Because plants do not have macrophages, dying cells must degrade their materials by themselves. In the case of rice seminal roots, the gas-space caused by lysigenous cell death expands radially, leaving behind structures derived from cell wall (Fig. 2). The first cell to collapse is located at a specific cell position in mid cortex (Kawai et al. 1998), and such lysigenous aerenchyma formation is regulated by ethylene (He et al. 1996). Furthermore, stresses such as NaCl treatment affect the cortical cell death and cell proliferation in roots of rice (Samarajeewa et al. 1999).

One of the common features of animal cells undergoing apoptosis is development of membrane asymmetry. Exposure of phosphatidyl serine (PS) on the outer and inner surface of plasma membrane triggers such phenomenon. Externalized PS appears to serve as an important signal for recognition and elimination of apoptotic cells by macrophages (Ceccatelli et al. 2004). Similar membrane asymmetry has also been observed in plants during PCD. In tobacco, changes in PS asymmetry, analyzed by measuring Annexin V bound to the cell membrane, were detected by a number of chemical agents (O'Brien et al. 1998). Similar findings were also reported in apple suspension cells under a low oxygen culture (Xu et al. 2004). However,

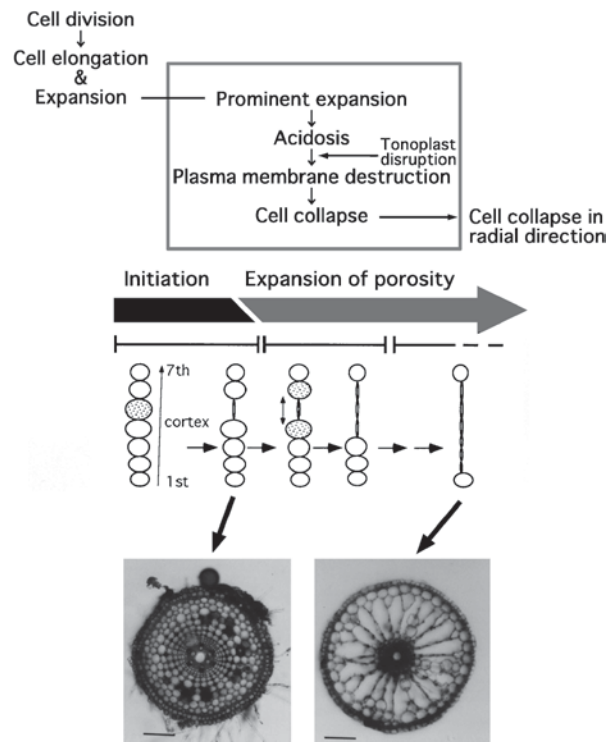

*Fig. 2.* Aerenchyma formation in rice roots follows a well designated cell fate. Lysigenous gas-space formation initiates at specific position of the mid cortex and expand toward basal portion of rice seminal root. In the neighborhood of the meristematic region, cell enlargement occurs. Cells in the mid cortex expand greatly, followed by acidification. Some cells in the mid cortex lose turgor pressure due to tonoplast disruption, followed by the loss of plasma-membrane integrity. Cells appear somewhat concave, lose contact with neighboring cells and collapse. Once cell collapse begins, neighboring cells die. The cavity then expands radially. Bar = 0.1 mm.

the physiological role of PS exposure in plants is still unknown.

### III Biochemistry of Cell Death

Much of the evidence for the concept of apoptosis in plants is derived from the observation of DNA fragmentation in cells entering the cell death phase. In animals, the cleavage of DNA has been found to occur at the inter-nucleosomal sites resulting in DNA fragments of 180 bp (Walker and Sikorska 1994). This form of DNA fragmentation can be detected by molecular detection of DNA ladders (multimers of 180 bp) on agarose gels. DNA laddering has been observed in plant tissues responding to fungal infection or phytotoxin exposure (Ryerson and Heath 1996; Wang et al. 1996a), in senescing carpels (Orza'ez and Granell 1997), in hormone treated aleurone

cells (Wang et al. 1996b), and in cells or tissues responding to abiotic stress treatments (Wang et al. 1996a). Using TUNEL assay, which detects PCD *in situ*, fragmented DNAs were detected in senescent leaves (Yen and Yang 1998), in tracheary element differentiation (Mittler and Lam 1995) and in senescent coleoptile (Kawai and Uchimiya 2000). Nuclear shrinkage is also presented as other apoptotic features in plant (Katsuhara and Kawasaki 1996; Orza'ez and Granell 1997).

Endonucleases responsible for plant cell death have been characterized. Ito and Fukuda (2000) identified ZEN1 as a key nuclease responsible for nuclear degradation during the terminal stages of tracheary element differentiation. ZEN1 is a  $Zn^{2+}$ -requiring nuclease and its activity is insulated in the vacuole.

In animal apoptosis, caspases, cytosolic family of cysteine proteases that specifically cleave adjacent to an aspartate residue, have pivotal



roles in execution of cell death (Thornberry et al. 1997). They are synthesized as inactive proenzymes and are activated by directed proteolytic removal of N-terminal peptide (Grutter 2000). In general, apoptotic cell death involves a sequence of caspase activation events in which initiator caspases such as Casp 8 and 9 activate downstream caspases (Casp 3, 6, 7) which in turn process a variety of target proteins eventually leading to the apoptotic phenotype (Woltering et al. 2002). Although the existence of caspase orthologs in plants is controversial, cysteine protease or caspase activity has been reported in plant systems undergoing PCD (Collazo et al. 2006). Uren et al. (2000) distinguished two families of caspase-like proteins, one from animals and slime mold and the other from plants, fungi, and protozoa. These are designated as paracaspases and metacaspases, respectively. The mcII-Pa protein, one of the metacaspase in *Picea abies* expressing in embryonic tissues is committed to PCD in embryogenesis (Suarez et al. 2004). Plant cell death can be suppressed using synthetic or natural caspase inhibitors. For example, VEIDase activity (equivalent to human caspase 6) was known as the main caspase-like activity in embryogenesis in *Picea abies* (Bozhkov et al. 2004). Expression of antiapoptotic baculovirus p35 gene, a caspase inhibitor in mammalian system, blocks PCD in tomato (Lincoln et al. 2002). Furthermore, caspase activities are detected in tobacco after invasion by pathogens (del Pozo and Lam 1998), in tomato after chemical-induced apoptosis (De Jong et al. 2000) and in *Arabidopsis* after treatment with nitric oxide (Clarke et al. 2000).

Recently, vacuolar processing enzyme (VPE) was identified as a plant caspase. VPE-deficient plants showed inhibited cell death in HR and in embryogenesis (Hara-Nishimura et al. 2005). Although VPE is not homologically related to the caspase family or metacaspase family, it shares similar enzymatic properties with caspase 1. Unlike animal apoptosis, plants might have evolved a cell death system that is, in some case, mediated by VPE.

#### IV Role of Vacuole

Cells destined to die are disposed off by the hydrolytic enzymes sequestered in the vacuoles (Jones 2001). The hydrolases sequestered in the

vacuole are released when the vacuole collapses. This collapse is an irreversible step towards death which results in the immediate cessation of cytoplasmic streaming and requires a calcium flux (Jones 2000, 2001).

This execution process is based on the integration of various signals such as auxins, cytokinins, ethylene and elicitors (Jones 2001). In tracheary elements differentiation, auxin and cytokinins induce the de novo synthesis of vacuole sequestered nucleases and proteases, leading to complete degradation of cellular content leaving behind the extracellular matrix and the secondary cell wall built before death (Gunawardena et al. 2004). During the formation of lysigenous aerenchyma, induced by ethylene, the dead cells are removed and the cell wall hydrolases, such as cellulase are induced to fulfill the need to remove not only the protoplasm but the extracellular matrix as well, resulting in gas space formation (Schussler and Longstreth 2000). Vacuolar hydrolytic enzymes are released into the cytosol to attack various organelles, leading to cell death (Fukuda 2004). The caspase 1-like cysteine protease, VPE, in plant is also localized in the vacuole (Hara-Nishimura et al. 2005). VPE deficiency suppresses vacuolar collapse leading to cell death, suggesting that VPE functions as a key molecule in vacuolar collapse-triggered cell death.

#### V Role of Mitochondrion

Mitochondria are major sites of energy conversion and carbon metabolism in the cell. Mitochondria play a central role in integrating signals, regulator and adaptor molecules for regulation and execution of mammalian cell death. Mitochondria can trigger apoptosis from diverse stimuli through the opening of mitochondrial permeability transition pore (MTP), which allows release of the apoptosis-inducing factor and translocation of cytochrome *c* into the cytosol (Green and Reed 1998). In *Arabidopsis* cells, oxidative stress increases mitochondrial electron transport, resulting in amplification of H<sub>2</sub>O<sub>2</sub> production, depletion of ATP and cell death. The increased generation of H<sub>2</sub>O<sub>2</sub> also caused the opening of MTP and the release of cytochrome *c* from mitochondria (Tiwari et al. 2002). The release of cytochrome *c* and cell death was prevented by a serine/cysteine protease inhibitor. ROS-treated plant mitochondria

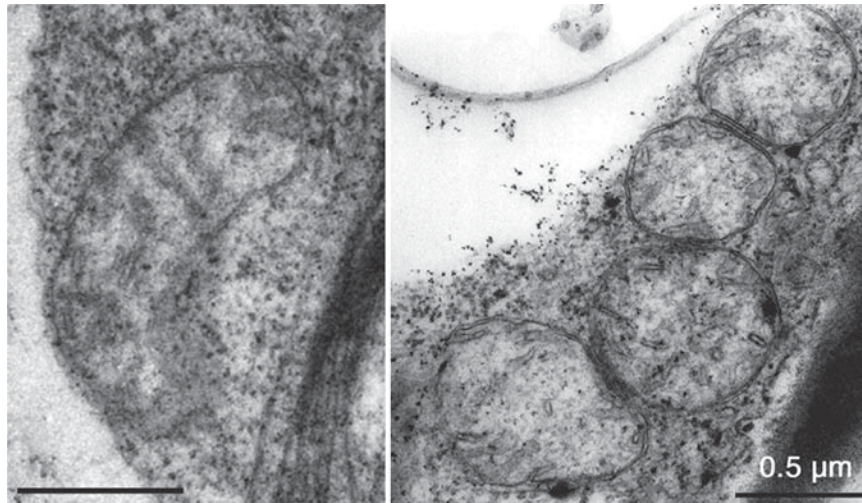

Fig. 3. Morphological changes in mitochondria during ROS-induced plant cell death. Mitochondria were observed by electron microscope at 0 (control, *left*) or 3 days (*right*) after cell death induction (Partially modified from Yoshinaga et al. 2005a).

showed morphological change from bacillus-like shape to a round shape (Fig. 3). Furthermore, the mitochondrial size decreased by half under ROS stress (Yoshinaga et al. 2005a, b). Mitochondrial fission proteins (Dnm1, Mdv1, Fis1) regulate cell death in animal and yeast cells by leading the mitochondrial fragmentation (Fannjiang et al. 2004; Karbowski et al. 2004). Such morphological changes suppress energy production of mitochondria and execute plant cell death.

In comparison to animal cells, plant mitochondrion has some unique components that alter mitochondrial functions towards PCD. One of these components is mitochondrial alternative oxidase (AOX) that functions as a part of an alternative electron pathway. This enzyme has been identified in *Arabidopsis* as an early induced gene in HR (Lancommme and Roby 1999). An over-expression of AOX in transgenic tobacco plants carrying the R gene resulted in reduced HR lesions following viral infection (Ordog et al. 2002). Furthermore, the treatment of tobacco cells with inhibitors of the cytochrome *c* pathway (Cys and antimycin A) was accompanied by a strong induction of the AOX capacity and the prevention of cell death (Vanlerberghe et al. 2002).

The host-selective toxin victorin, produced by *Cochliobolus victoriae* causes Victoria blight of oat. Victorin binds to P protein of the glycine decarboxylase (GD) complex localized in

the mitochondrial matrix (Wolpert et al. 1994), inhibits GD activity, and induces apoptosis-like responses such as chromatin condensation and DNA laddering (Navarre and Wolpert 1995; Yao et al. 2001; Guo and Crawford 2005).

Furthermore, Kim et al. (2006) showed that virus-induced gene silencing (VIGS) of mitochondrial hexokinase caused necrotic lesion of leaves in *Nicotiana benthamiana*. These cells also showed nuclear condensation and DNA fragmentation, which are morphological markers of PCD. These findings suggest a pivotal role of mitochondria in the regulation of plant cell death.

## VI Role of Chloroplast

Light requirement for PCD has often been associated with the production of ROS during photosynthesis (Martienssen 1997). Seo et al. (2000) demonstrated that the DS9 gene encoding FtsH protein in chloroplast is involved in the cell death regulation in tobacco mosaic virus (TMV)-mediated HR. Transgenic tobacco over-expressing DS9 stimulated HR cell death. In contrast, DS9 deficient plant displays less necrotic lesions. *Arabidopsis* mutant *psi2* (phytochrome signaling) showed light dependent super-induction of the pathogen-related protein PR-1a and developed spontaneous necrotic lesions in the absence of pathogen infection (Genoud et al. 1998). The PSI2

product negatively regulates photo-transduction pathways downstream of both phyA and phyB.

The lesion initiation 1 (*len1*) mutant of *Arabidopsis*, having the defective chloroplast chaperonin (Cpn60), developed lesions on its leaves in a light dependent manner. The *len1* leaves had a wrinkled irregular surface and displayed lesion formation when they were grown under short-day conditions. Under long-day conditions, the lesion formation was suppressed (Ishikawa et al. 2003). In addition, *lls1* (lethal leaf spot 1) mutant in maize is also characterized by the light-dependent formation of necrotic spots (Gray et al. 2002). The *Lls1* gene encodes a protein possessing Rieske-type Fe-sulfur center domain. In *acd2 Arabidopsis* mutant, the photo-activation of the red chlorophyll catabolite triggers free radical production and subsequent cell death (Mach et al. 2001). These results clearly support the notion that light energy is used directly or indirectly to produce cell death mediators such as ROS or phototoxic chlorophyll intermediates, triggering the death.

## VII Signals in Cell Death

Signals that initiate the process of cell death are passed on inside the cell through a number of cascades (Fig. 4). These signals, especially ROS signal

is believed to be mediated through alterations in  $\text{Ca}^{2+}$ -fluxes, redox changes, ATP depletion, membrane vulnerability, ion leakage and disruptions to cellular function. For example, the altered NAD(P)H pool may confer the prevention of ROS-induced cell death (Hayashi et al. 2005).

The death receptors belong to the tumour necrosis factor (TNF) receptor super family or to the Fas receptors in animals and proteins encoded by R genes in plants (Kam 2000). The R genes are activated through specific interactions with avirulence proteins generated only by certain types of pathogens. The R genes encode several classes of proteins possessing domains of nucleotide binding sites (NBS), leucine-rich repeats (LRR), transmembrane domains (TM), and serine threonine protein kinases (PK). The majority of these proteins have the NBS-LRR structure and are believed to be functionally confined to disease resistance. This class of R proteins may be further subdivided depending on the presence or absence of an N-terminal Toll/IL-1 receptor (TIR) domain. The NBS domain shows homology to regions found in the pro-apoptotic regulator Apaf-1 (Van der Biezen and Jones 1998). Apaf-1 and these proteins also share a similar structural organization. Thus, the common nucleotide binding (NBS) domain shared by these proteins links an effector domain (CARD in Apaf-1

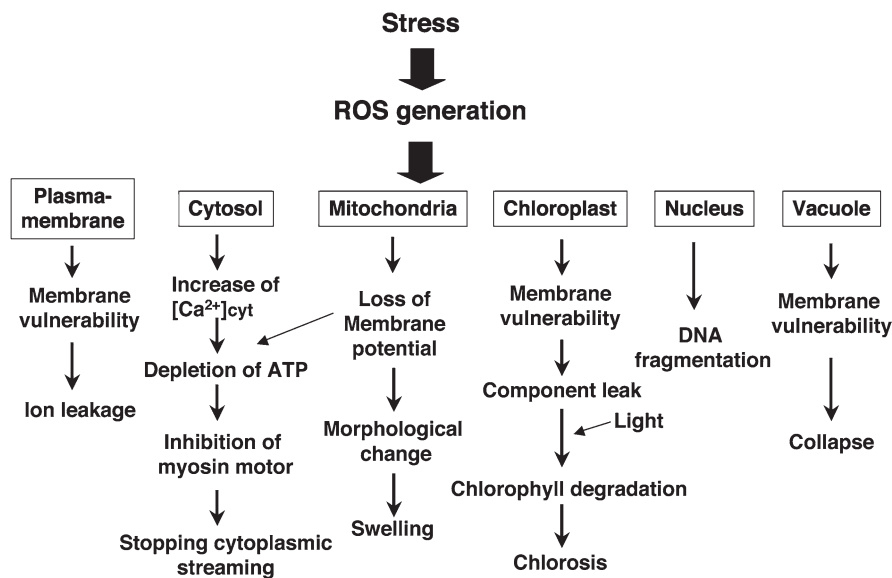

Fig. 4. Biological processes leading to oxidative stress-induced cell death. Abiotic and biotic stresses lead to ROS accumulation, which triggers orchestrated events in plant cells.

and TIR in these proteins) to a C-terminal domain likely to be involved in protein-protein interactions [WD domains in Apaf-1 and LRR domain in R proteins] and both are involved in cell death (Inohara et al. 1999).

As in the case of animals, following the receipt of a stimulus plant death receptors are activated, which in turn affect a number of signal pathways by protein phosphorylation, lipid-mediated signaling and a modification in ion fluxes. Mitogen-activated protein kinase (MAPK) cascades have become one of the most widely studied pathways of phosphorylation signaling related to PCD. Two *Arabidopsis* MAPKKs, AtMEK4 and AtMEK5, are functionally interchangeable with tobacco NtMEK2 in activating the downstream MAPKs. In the case of transient transformation experiments, performed in tobacco, the active forms of AtMEK4 and AtMEK5 activate endogenous tobacco SIPK and WIPK. These two MAPKKs, as well as tobacco NtMEK2 also activate two endogenous MAPKs, followed by the HR-like cell death (Ren et al. 2002). Oxidative stress-activated MAP triple kinase 1 (OMTK1) can specifically activate the downstream MAP kinase MMK3, which can also be activated by ethylene and elicitors, thus serving as a convergence point of the cell death network (Nakagami et al. 2004).

The activity of protein kinases is simultaneously regulated by cofactors and second messengers such as calcium. A MAPK phosphatase gene (NtMKP1), ortholog of *Arabidopsis* MKP1, was isolated as a candidate gene for a calmodulin (CaM)-binding protein from tobacco. In transgenic tobacco over-expressing NtMKP1, the wound-induced activation of SIPK, salicylic acid-induced MAPK and WIPK were inhibited. These results suggest that plant CaMs are involved in these stress-activated MAPK cascades via NtMKP1 (Yamakawa et al. 2004).

Sphingolipids are essential components of eukaryotic membranes that not only serve as modulators of extracellular interactions and cell surface receptors but also have critical functions as intracellular signaling messengers. The sphingolipid pathway generates three signaling metabolites known to function in intracellular signaling i.e., ceramide, sphingosine and sphingosine-1-phosphate. These metabolites play important roles in cell growth and differentiation (Hannun and Obeid 2002; Liang et al. 2003).

Ceramide signaling pathway serves as a critical second-messenger system and has been studied in detail to understand apoptosis during degenerative and proliferative disease expressions in animal systems. The balance between the bioactive sphingolipid ceramide and its phosphorylated derivatives modulate PCD in animals as well as plants (Hannun and Obeid 2002). As second messengers, sphingolipids and sphingoid bases regulate cell behavior at many levels, including cell-to-cell communication, growth factor receptors, growth, differentiation and transformation (Ng and Hetherington 2001). The interplay between sphingolipid metabolite sphingosine-1-phosphate and heterotrimeric G-proteins represents an evolutionary conserved signal transduction mechanism in plants (Coursol et al. 2003). *Arabidopsis* ceramide kinase (CERK) mutant, called *acd5*, accumulated CERK substrates, and showed apoptosis-like phenotype (Liang et al. 2003). Acid tolerance response 1 (*Atr1*) mutants, tolerant to AAL toxin, are also resistant to H<sub>2</sub>O<sub>2</sub>-induced death, suggesting the involvement of ROS in sphingolipid metabolism for regulation of cell death (Gechev and Hille 2005).

## VIII Cell Death Regulator

Bax, known as a mammalian proapoptotic protein, causes cell death when expressed in plants and yeast (Madeo et al. 1999; Baek et al. 2004; Yoshinaga et al. 2005a, b). Using such heterologous system, candidates of plant cell death regulators were isolated (Kawai-Yamada et al. 2005a, b). Bax inhibitor-1 (BI-1) is one such death suppressor that is conserved in metazoans and plants (Xu and Reed 1998; Lam et al. 2001; Chae et al. 2003; Hückelhoven 2004). Plant BI-1 genes isolated from rice (Kawai et al. 1999), *Arabidopsis* (Kawai et al. 1999; Sanchez et al. 2000; Yu et al. 2002), tobacco (Bolduc and Brisson 2003), *Brassica* (Bolduc and Brisson 2003) and barley (Hückelhoven et al. 2001) have been intensively studied in yeast, plant and mammalian system. The BI-1 protein has six or seven transmembrane domains and is localized in the endoplasmic reticulum (ER) membrane (Xu and Reed 1998; Kawai-Yamada et al. 2001; Bolduc et al. 2003). Plant cells over-expressing AtBI-1 demonstrated cell death suppression in response to Bax-, salicylic acid-,



		Charge of replaced amino acid	Score for coiled-coil	Cell death suppression
AtBI-1	NSADKEEKKKRRRN	+	0.88	+
AtBI28	NSADKEEEEEEN	-	0.99	+
AtBI29	NSADKEEQQQNNN	non	0.84	+
AtBI30	NSADKEEIIIGGN	non	0.01	-
AtBI31	NSAKKKKKKRRRN	+	0.80	+
AtBI32	NSANNQKKKKRRRN	non	0.72	+

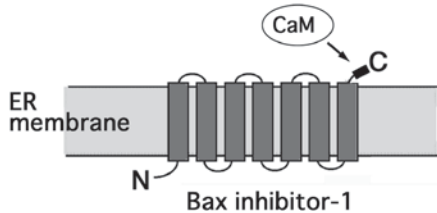

Fig. 5. The C-terminal region of AtBI-1 is essential for the cell death inhibition. The C-terminal 14 amino acids of AtBI (original) were replaced in mutants (AtBI-28-32). The score for the coiled-coil structure and the ability for cell death suppression are indicated. The AtBI30 mutant lacking coiled-coil structure failed to inhibit cell death, suggesting that the C-terminal region is essential for the inhibition of cell death through protein-protein interaction (Ihara-Ohori et al. 2007)

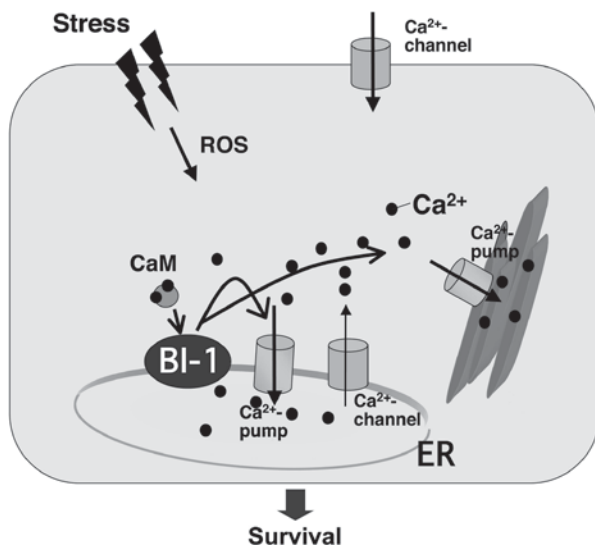

Fig. 6. Proposed model of calcium flux and BI-1. BI-1 may regulate calcium flux at ER in response to stresses, leading to inhibition of cell death in plant cells. ROS stimulation caused by various stress conditions induces an increase of  $[Ca^{2+}]_{cyt}$  through  $Ca^{2+}$ -channels. In contrast, the  $Ca^{2+}$ -pump uptake calcium into internal stores such as endoplasmic reticulum (ER) and golgi to prevent elevation of  $[Ca^{2+}]_{cyt}$ . Regulation of intracellular  $Ca^{2+}$  homeostasis is crucial for suppressing cell death. The CaM-binding BI-1 may regulate  $Ca^{2+}$  flux at ER. BI, Bax inhibitor-1, CaM, calmodulin

elicitor-, and  $H_2O_2$ -induced cell death (Kawai-Yamada et al. 2001; Matsumura et al. 2003; Kawai-Yamada et al. 2004). AtBI-1 may act down-stream of ROS generation (Kawai-Yamada et al. 2004). The C-terminal mutant of AtBI-1, lacking a coiled-coil structure, fails to inhibit cell death (Fig. 5). Recently, calmodulin was isolated as an interactant of C-terminal region of AtBI-1 (Ihara-Ohori et al. 2007). Calmodulin binding to AtBI-1 modulates calcium flux in plant cells. The AtBI-1 over-expressing or knock-down plants demonstrated an altered sensitivity against CPA (inhibitor of SERCA type  $Ca^{2+}$ -ATPases) and ion stresses, suggesting that AtBI-1 plays a role in ion homeostasis in case of plant cell death regulation (Fig. 6).

## IX Conclusions

Cell death in multicellular organisms is aimed at the removal of unuseful cells and is essential to the development and maintenance of organism. Despite the recent progress in our understanding of plant cellular events, numerous uncertainties remain. ROS accumulation in response to various biotic and abiotic stresses has been implicated in programmed cell death. The ROS cause oxidative damage to membrane lipids, proteins and nucleic acids in cells and these intracellular changes are believed to trigger-off a variety of responses in plant cells. The ROS signal is believed to be mediated through alterations in  $Ca^{2+}$ -fluxes, redox changes, ATP depletion, membrane vulnerability, ion leakage and disruptions to cellular functioning.

Further work in this field, such as the analysis of  $Ca^{2+}$  and redox signaling, are likely to elucidate the associated molecular mechanisms responsible for regulating plant cell death and survival under various stresses. Such studies may provide new strategies to develop crop resistant to biotic and abiotic stresses (Dhariwal et al., 1998; Dhariwal and Uchimiya, 1999).

## References

- Baek D, Nam J, Koo YD, Kim DH, Lee J, Jeong JC, Kwak SS, Chung WS, Lim CO, Bahk JD, Hong JC, Lee SY, Kawai-Yamada M, Uchimiya H, Yun DJ (2004) Bax-induced cell death of *Arabidopsis* is mediated through

- reactive oxygen-dependent and -independent processes. *Plant Mol Biol* 56:15–27
- Bolduc N, Brisson LF (2003) Antisense down regulation of NtBI-1 in tobacco BY-2 cells induces accelerated cell death upon carbon starvation. *FEBS Lett* 532:111–114
- Bolduc N, Ouellet M, Pitre F, Brisson LF (2003) Molecular characterization of two plant BI-1 homologues which suppress Bax-induced apoptosis in human 203 cells. *Planta* 216:377–386
- Bozhkov PV, Filonova LH, Suarez MF, Helmersson A, Smertenko AP, Zhivotovsky B, Von Arnold S (2004) VEIDase is a principal caspase-like activity involved in plant programmed cell death and essential for embryonic pattern formation. *Cell Death Differ* 11:175–182
- Ceccatelli S, Tamm C, Sleeper E, Orrenius S (2004) Neural stem cells and cell death. *Toxicol Lett* 149:59–66
- Chae HJ, Ke N, Kim HR, Chen S, Godzik A, Dickman M, Reed JC (2003) Evolutionarily conserved cytoprotection provided by Bax inhibitor-1 homolog from animals, plants and yeast. *Gene* 323:101–113
- Clarke A, Desikan R, Hurst RD, Hancock JT, Neil SK (2000) NO way back: nitric oxide and programmed cell death in *Arabidopsis thaliana* suspension cultures. *Plant J* 24:667–677
- Collazo C, Osmani C, Orlando B (2006) Programmed cell death in plants resembles apoptosis in animals. *Biotechnology Aplicada* 23:1–10
- Coursol S, Fan L-M, Le Stunff H, Spiegel S, Gilroy S, Assmann SM (2003) Sphingolipid signaling in *Arabidopsis* guard cells involves heterotrimeric G proteins. *Nature* 423:651–654
- De Jong AJ, Hoeberichts FA, Yakimova ER, Maximova E, Woltering EJ (2000) Chemical-induced apoptotic cell death in tomato cells: involvement of caspase-like proteases. *Planta* 211:656–662
- De Long A, Calderon-Urrea A, Dellaport SL (1993) Sex determination gene Tasselseed2 of maize encodes a short-chain alcohol dehydrogenase required for stage-specific floral organ abortion. *Cell* 74:717–768
- Del Pozo O, Lam E (1998) Caspases and programmed cell death in the hypersensitive response of plants to pathogens. *Curr Biol* 8:1129–1132
- Dhariwal HS, Uchimiya H (1999) Genetic engineering for disease and pest resistance in plants. *Plant Biotechnol* 16:255–261
- Dhariwal HS, Kawai M, Uchimiya H (1998) Genetic engineering for abiotic stress tolerance in plants. *Plant Biotechnol* 15:1–10
- Fannjiang Y, Cheng WC, Lee SJ, Qi B, Pevsner J, McCaffery JM, Hill RB, Basanez G, Hardwick JM (2004) Mitochondrial fission proteins regulate programmed cell death in yeast. *Genes Dev* 18:2785–2797
- Fukuda H (2004) Signals that control plant vascular cell differentiation. *Nat Rev Mol Cell Biol* 5:379–391
- Gan S, Amasino RM (1997) Making sense of senescence: Molecular genetic regulation and manipulation of leaf senescence. *Plant Physiol* 113:313–319
- Gechev TS, Hille J (2005) Hydrogen peroxide as a signal controlling plant programmed cell death. *J Cell Biol* 168:17–20
- Genoud T, Millar AJ, Nishizawa N, Kay SA, Schafer E, Nagatani A, Chua NH (1998) An *Arabidopsis* mutant hypersensitive to red and far-red light signals. *Plant Cell* 10:889–904
- Giuliani C, Consonni G, Gavazzi G, Colombo M, Dolfini S (2002) Programmed cell death during embryogenesis in maize. *Ann Bot* 90:287–292
- Gray J, Janick-Buckner D, Buckner B, Close PS, Johal GS (2002) Light-dependent death of maize *lls1* cells is mediated by mature chloroplasts. *Plant Physiol* 130:1894–1907
- Green DR, Reed JC (1998) Mitochondria and apoptosis. *Science* 281:1309–1312
- Grutter MG (2000) Caspases: key players in programmed cell death. *Curr Opin Struct Biol* 10:649–655
- Gunawardena A, Greenwood JS, Dengler N (2004) Programmed cell death remodels lace plant leaf shape during development. *Plant Cell* 16:70–73
- Guo FQ, Crawford NM (2005) *Arabidopsis* nitric oxide synthase1 is targeted to mitochondria and protects against oxidative damage and dark-induced senescence. *Plant Cell* 17:3436–3450
- Hancock JT, Desikan R, Clarke A, Hurst RD, Neill SJ (2002) Cell signaling following plant/pathogen interactions involves the generation of reactive oxygen and reactive nitrogen species. *Plant Physiol Biochem* 40:611–617
- Hannun YA, Obeid LM (2002) The ceramide centric universe of lipid-mediating cell regulation: Stress encounters of the lipid kind. *J Biol Chem* 277:25847–25850
- Hara-Nishimura I, Hatsugai N, Nakane S, Kuroyanagi M, Nishimura M (2005) Vacuolar processing enzyme: an executor of plant cell death. *Curr Opin Plant Biol* 8:404–408
- Havel L, Durzan DJ (1996) Apoptosis during diploid parthenogenesis and early somatic embryogenesis of Norway spruce. *Int J Plant Sci* 157:8–16
- Hayashi M, Takahashi H, Tamura K, Huang J, Yu LH, Kawai-Yamada M, Tezuka T, Uchimiya H (2005) Enhanced dihydroflavonol-4-reductase activity and NAD homeostasis leading to cell death tolerance in transgenic rice. *Proc Natl Acad Sci USA* 102:7020–7025
- He CJ, Morgan PW, Drew MC (1996) Transduction of an ethylene signal is rewired for cell death and lysis in the root cortex of maize during aerenchyma formation induced by hypoxia. *Plant Physiol* 112:463–472
- He X, Kermode AR (2003) Nuclease activities and DNA fragmentation during programmed cell death of megagametophyte cells of white spruce (*Picea glauca*) seeds. *Plant Mol Biol* 51:509–521
- Houot V, Etienne P, Petitot AS, Barbier S, Blein JP, Sudy L (2001) Hydrogen peroxide induces programmed cell death features in cultured tobacco BY-2 cells in a dose-dependent manner. *J Exp Bot* 52:1721–1730

- Hückelhoven R (2004) BAX inhibitor-1, an ancient cell death suppressor in animals and plants with prokaryotic relatives. *Apoptosis* 9:299–307
- Hückelhoven R, Dechert C, Kogel KH (2001) Differential expression of putative cell death regulator genes in near isogenic, resistant and susceptible barley lines during interaction with powdery mildew fungus. *Plant Mol Biol* 47:739–748
- Ihara-Ohori Y, Nagano M, Muto S, Uchimiya H, Kawai-Yamada M (2007) Cell death suppressor *Arabidopsis* Bax inhibitor-1 is associated with calmodulin binding and ion homeostasis. *Plant Physiol* 143:1–11
- Inohara N, Koseki T, del Paso L, Hu Y, Yee C, Chen S, Cario R, Merino J, Liu D, Ni A, Nuñez J (1999) Nod 1, an Apaf-1-like activator of caspase 9 and nuclear factor-kappa B. *J Biol Chem* 274:14560–14567
- Ishikawa A, Tanaka H, Nakai M, Asahi T (2003) Deletion of a chaperonin 60 beta gene leads to cell death in the *Arabidopsis* lesion initiation 1 mutant. *Plant Cell Physiol* 44:255–261
- Ito J, Fukuda H (2000) ZEN1 is a key enzyme in the degradation of nuclear DNA during programmed cell death of tracheary elements. *Plant Cell* 14:3201–3211
- Jones A (2000) Does the plant mitochondrion integrate cellular stress and regulate programmed cell death? *Trends Plant Sci* 5:1360–1385
- Jones AM (2001) Programmed cell death in development and defense. *Plant Physiol* 125:94–99
- Kam PCA (2000) Apoptosis: mechanisms and clinical implications. *Anaesthesia* 55:1081–1093
- Karbowski M, Arnoult D, Chen H, Chan DC, Smith CL, Youle RJ (2004) Quantitation of mitochondrial dynamics by photolabeling of individual organelles shows that mitochondrial fusion is blocked during the Bax activation phase of apoptosis. *J Cell Biol* 164:493–499
- Katsuhara M, Kawasaki T (1996) Salt stress induced nuclear and DNA degradation in meristematic cells of barley roots. *Plant Cell Physiol* 37:169–173
- Kawai M, Uchimiya H (2000) Coleoptile senescence in rice. *Ann Bot* 86:405–414
- Kawai M, Samarajeewa PK, Barrero RA, Nishiguchi M, Uchimiya H (1998) Cellular dissection of the degradation pattern of cortical cell death during aerenchyma formation of rice roots. *Planta* 204:277–287
- Kawai M, Pan L, Reed JC, Uchimiya H (1999) Evolutionally conserved plant homologue of the Bax-induced cell death in yeast. *FEBS Lett* 64:143–147
- Kawai-Yamada M, Jin L, Yoshinaga K, Hirata A, Uchimiya H (2001) Mammalian Bax-induced plant cell death can be down regulated by over-expression of *Arabidopsis* Bax inhibitor-1 (AtBI-1). *Proc Natl Acad Sci USA* 98:12295–12300
- Kawai-Yamada M, Ohori Y, Uchimiya H (2004) Dissection of *Arabidopsis* Bax inhibitor-1 suppressing Bax, hydrogen peroxide and salicylic acid-induced cell death. *Plant Cell* 16:21–32
- Kawai-Yamada M, Saito Y, Jin L, Ogawa T, Kim KM, Yu LH, Tone Y, Hirata A, Umeda M, Uchimiya H (2005a) A novel *Arabidopsis* gene causes Bax-like lethality in *Saccharomyces cerevisiae*. *J Biol Chem* 280:39468–39473
- Kawai-Yamada M, Yoshinaga K, Ogawa T, Ihara-Ohori Y, Uchimiya H (2005b) Oxidative stress and plant cell death suppressors. *Plant Biotechnol* 22:419–422
- Kim M, Lim JH, Ahn CS, Park K, Kim GT, Kim WT, Pai HS (2006) Mitochondria-associated hexokinases play a role in the control of programmed cell death in *Nicotiana benthamiana*. *Plant Cell* 18:2341–2355
- Kozela C, Regan S (2003) How plants make tubes? *Trends Plant Sci* 8:159–164
- Lam E (2004) Controlled cell death: plant survival and development. *Nat Rev Mol Cell Biol* 5:305–315
- Lam E, Kato N, Lawton M (2001) Programmed cell death, mitochondria and the plant hypersensitive response. *Nature* 411:848–853
- Lancomme C, Roby D (1999) Identification of new early markers of the hypersensitive response in *Arabidopsis thaliana*. *FEBS Lett* 459:149–153
- Levine A, Tenhaken R, Dixon R, Lamb C (1994) H<sub>2</sub>O<sub>2</sub> from the oxidative burst orchestrates the plant hypersensitive disease resistance response. *Cell* 79:583–593
- Liang H, Yao N, Song JT, Luo S, Lu H, Greenberg T (2003) Ceramides modulate programmed cell death in plants. *Genes Dev* 17:2636–2641
- Lincoln JE, Michael C, Overduin B, Smith K, Bostock R, Gilchrist DG (2002) Expression of antiapoptotic baculovirus p35 gene in tomato blocks programmed cell death and provide broad-spectrum resistance to disease. *Proc Natl Acad Sci USA* 99:15217–15221
- Mach JM, Castillo AR, Hoogstraten R, Greenberg JT (2001) The *Arabidopsis*-accelerated cell death gene ACD2 encodes red chlorophyll catabolite reductase and suppresses the spread of disease symptoms. *Proc Natl Acad Sci USA* 98:771–776
- Madeo F, Fröhlich E, Ligr M, Grey M, Sigrist SJ, Wolf DH, Fröhlich KU (1999) Oxygen stress: a regulator of apoptosis in yeast. *J Cell Biol* 145:757–767
- Martienssen R (1997) Cell death: fatal induction in plants. *Curr Biol* 7:R534–R537
- Martins LM, Earnshaw WC (1997) Apoptosis: Alive and kicking in 1997. *Trends Cell Biol* 7:111–114
- Matsumura H, Nirasawa S, Kiba A, Urasaki N, Saitoh H, Ito M, Kawai-Yamada M, Uchimiya H, Terauchi R (2003) Over-expression of Bax-inhibitor suppresses the fungal elicitor-induced cell death in rice (*Oryza sativa* L.) cells. *Plant J* 33:425–434
- Mittler R, Lam E (1995) *In situ* detection of nDNA fragmentation during the differentiation of tracheary elements in higher plants. *Plant Physiol* 108:489–493
- Mittler R, Lam E (1997) Pathogen-induced programmed cell death in tobacco. *Plant Mol Biol* 34:209–221
- Moller SG, McPherson MJ (1998) Developmental expression and biochemical analysis of the *Arabidopsis* atao1

- gene encoding an H<sub>2</sub>O<sub>2</sub>-generating diamine oxidase. *Plant J* 13:781–791
- Nakagami H, Kiegerl S, Hirt H (2004) OMTK1, a novel MAPKKK, channels oxidative stress signaling through direct MAPK interaction. *J Biol Chem* 279:26959–26966
- Nakashima J, Takabe M, Fukuda H (2000) Autolysis during *in vitro* tracheary element differentiation: formation and location of the perforation. *Plant Cell Physiol* 4: 1267–1271
- Navarre DA, Wolpert TJ (1995) Inhibition of the glycine decarboxylase multienzyme complex by the host-selective toxin victorin. *Plant Cell* 7:463–471
- Ng CKY, Hetherington AM (2001) Sphingolipid-mediated signaling in plants. *Ann Bot* 88:95–965
- Ordog SH, Higgins VJ, Vanlerberghe GC (2002) Mitochondrial alternative oxidase is not a critical component of plant viral resistance but may play a role in the hypersensitive response. *Plant Physiol* 129:1858–1865
- Orza'ez D, Granell A (1997) DNA fragmentation is regulated by ethylene during carpel senescence in *Pisum sativum*. *Plant J* 11:137–144
- O'Brien IE, Baguley BC, Murray BG, Morris BA, Ferguson IB (1998) Early stages in the apoptotic pathway in plant cells are reversible. *Plant J* 3:803–814
- Paris N, Stanley CM, Jones RL, Rogers JC (1996) Plant cells contain two functionally distinct vacuolar compartments. *Cell* 85:563–572
- Pennell RI, Lamb C (1997) Programmed cell death in plants. *Plant Cell* 9:1157–1168
- Ren D, Yang H, Zhang S (2002) Cell death mediated by MAPK is associated with hydrogen peroxide production in *Arabidopsis*. *J Chem Biol* 4:559–565
- Ryerson DE, Heath MC (1996) Cleavage of nuclear DNA into oligonucleosomal fragments during cell death induced by fungal infection or by abiotic treatments. *Plant Cell* 8:393–402
- Samarajeeva PK, Barrero RA, Umeda-Hara C, Kawai M, Uchimiya H (1999) Cortical cell death, cell proliferation, macromolecular movements and rTip1 expression pattern in roots of rice (*Oryza sativa* L.) under NaCl stress. *Planta* 207:354–361
- Sanchez P, de Torres-Zabala M, Grant M (2000) AtBI-1, a plant homologue of Bax inhibitor-1, suppresses Bax-induced cell death in yeast and is rapidly up-regulated during wounding and pathogen challenge. *Plant J* 21:393–399
- Schussler EE, Longstreth DJ (2000) Changes in cell structure during the formation of root aerenchyma in *Sagittaria lancifolia* (Alismataceae). *Am J Bot* 87:12–19
- Seo S, Okamoto M, Iwai T, Iwano M, Fukui K, Isogai A, Nakajima N, Ohashi Y (2000) Reduced levels of chloroplast FtsH protein in tobacco mosaic virus-infected tobacco leaves accelerate the hypersensitive reaction. *Plant Cell* 12:917–932
- Suarez MF, Filonova LH, Smertenko A, Savenkov EI, Clapham DH, von Arnold S, Zhivotovsky B, Bozhkov PV (2004) Metacaspase-dependent programmed cell death is essential for plant embryogenesis. *Curr Biol* 14:R339–R340
- Thornberry NA, Rosen A, Nicholson DW (1997) Control of apoptosis by proteases. *Adv Pharmacol* 41:155–177
- Tiwari BS, Belenghi B, Levine A (2002) Oxidative stress increased respiration and generation of reactive oxygen species, resulting in ATP depletion, opening of mitochondrial permeability transition, and programmed cell death. *Plant Physiol* 128:1271–1281
- Uren AG, O'Rourke K, Aravind L, Pisabarro MT, Seshagiri S, Koonin EV, Dixit VM (2000) Identification of paracaspases and metacaspases: two ancient families of caspase-like proteins, one of which plays a key role in MALT lymphoma. *Mol Cell* 6:961–967
- Van der Biezen EA, Jones JD (1998) The NBARC domain: a novel signaling motif shared by plant resistance gene products and regulators of cell death in animals. *Curr Biol* 8:226–267
- Vanlerberghe GC, Robson CA, Yip JYH (2002) Induction of mitochondrial alternative oxidase in response to a cell signal pathway down-regulating the cytochrome *c* pathway prevents programmed cell death. *Plant Physiol* 129:1829–1842
- Walker PR, Sikorska M (1994) Endonuclease activities, chromatin structure and DNA degradation in apoptosis. *Biochem Cell Biol* 72:615–623
- Wang H, Li J, Bostock RM, Gilchrist DG (1996a) Apoptosis: a functional paradigm for programmed plant cell death induced by a host-selective phytotoxin and invoked during development. *Plant Cell* 8:375–391
- Wang M, Oppedijk BJ, Lu X, Van Duijn V, Schilperoord RA (1996b) Apoptosis in barley aleurone during germination and its inhibition by abscisic acid. *Plant Mol Biol* 32:1125–1134
- Wolpert TJ, Navarre DA, Moore DL, Macko V (1994) Identification of the 100 kD victorin binding protein from oats. *Plant Cell* 6:1145–1155
- Woltering EJ, Van der Bent A, Hoeberichts A (2002) Do plant caspases exist? *Plant Physiol* 130:1764–1769
- Xu CJ, Chen KS, Ferguson IB (2004) Programmed cell death feature in apple suspension cells under low oxygen culture. *J Zhejiang Univ Sci* 5:137–143
- Xu Q, Reed JC (1998) Bax inhibitor-1, a mammalian apoptosis suppressor identified by functional screening in yeast. *Mol Cell* 1:337–346
- Yamakawa H, Katou S, Seo S, Mitsuhara I, Kamada H, Ohashi Y (2004) Plant mitogen activated protein kinase phosphatase interacts with calmodulins. *J Biol Chem* 279:928–936
- Yao N, Tada Y, Park P, Nakayashiki H, Tosa Y, Mayama S (2001) Novel evidence for apoptotic cell response and differential signals in chromatin condensation and DNA cleavage in victorin-treated oats. *Plant J* 28:13–26
- Yen CH, Yang CH (1998) Evidence for programmed cell death during leaf senescence in plants. *Plant Cell Physiol* 39:922–927



- Yoshinaga K, Arimura S, Hirata A, Niwa Y, Yun DJ, Tsutsumi N, Uchimiya H, Kawai-Yamada M (2005a) Mammalian Bax initiates plant cell death through organelle destruction. *Plant Cell Rep* 24:408–417
- Yoshinaga K, Arimura S, Niwa Y, Tsutsumi N, Uchimiya H, Kawai-Yamada M (2005b) Mitochondrial behavior in the early stages of ROS stress leading to cell death in *Arabidopsis thaliana*. *Ann Bot* 96:337–342
- Yu LH, Kawai-Yamada M, Naito M, Watanabe K, Reed JC, Uchimiya H (2002) Induction of mammalian cell death by a plant Bax inhibitor. *FEBS Lett* 512:308–312
- Zhang XG, Cote GG, Crain RC (2002) Involvement of phosphoinositide turnover in tracheary element differentiation in *Zinnia elegans* L. cells. *Planta* 215:312–318

# Part IV

## Overcoming Stress

## Varietal Improvement for Abiotic Stress Tolerance in Crop Plants: Special Reference to Salinity in Rice

Rakesh Kumar Singh\*, Edilberto Redoña, and Luzminda Refuerzo  
*Plant Breeding, Genetics and Biotechnology Division,  
International Rice Research Institute, Los Baños, Philippines*

Summary .....	388
I Introduction .....	389
II The Need for Abiotic Stress-Tolerant Cultivars.....	389
III Past Breeding Efforts .....	390
IV Limits of Plant Stress Tolerance .....	392
A Intercrop Variability.....	392
B Intracrop Variability (Intervarietal/Genotypic Tolerance).....	392
V Breeding Salinity Tolerance with High Yield.....	393
VI The Concept of Heritability.....	394
VII Genetics of Salt Tolerance.....	396
A Inheritance Studies .....	396
B Association Studies.....	396
C Gene Action and Heritability .....	397
D Combining Ability Analysis.....	397
E Heterosis .....	397
VIII Breeding Methodology.....	398
A Conventional Approaches .....	398
1 Selection and Introduction.....	398
2 Pedigree Method .....	398
3 Modified Bulk Pedigree Method.....	398
4 Shuttle Breeding.....	398
5 Mutation Breeding .....	398
6 Diallel Selective Mating System Supplemented by MAS.....	399
B DSMS Methodology.....	399
C Non-conventional Approaches .....	401
1 F <sub>1</sub> Anther Culture Technique.....	401
2 MAS and Transgenics .....	401
IX Screening Methodology .....	401
A Screening Techniques .....	401
1 In-situ Field Evaluation .....	401
2 Screening in Microplots.....	401
3 Screening in Pots .....	402
4 Salinity Screening in Solution Culture .....	402
5 Screening in Trays.....	403
B Screening Criteria.....	403
1 Morphological Parameters .....	404
2 Germination Parameters.....	404

---

\* Author for Correspondence, e-mail: r.k.singh@cgiar.org

3	Plant Survival.....	404
4	Injury Score .....	404
5	Phenotypic Expression .....	404
6	Growth Parameters.....	404
7	Grain Yield .....	404
8	Stability of Traits over Environments .....	404
9	Mean Tolerance Index (MTI) .....	404
10	Associated Traits.....	405
11	Physiological and Biochemical Parameters.....	405
C	Selection Pressure .....	405
X	Breeding Strategy to Enhance Salinity Tolerance Through Pyramiding of Mechanisms.....	405
XI	Testing Approaches for Varietal Adaptability .....	406
A	Station Trials.....	406
B	Target Area-Based/Network Approach.....	406
C	Farmer's Participatory Approach.....	406
XII	Factors Affecting Salt Tolerance .....	408
A	Agronomic Factors .....	408
B	Climatic Factors.....	408
C	Soil Texture and Structure .....	409
D	Rainfall .....	409
XIII	Collaborative Research .....	409
XIV	Rice Varieties Developed for Salt Tolerance.....	410
XV	Impact of Salt-Tolerant Rice Varieties.....	411
A	Direct Impact .....	411
B	Indirect Impact.....	411
XVI	Conclusions.....	411
XVII	Recommendations and Future Lines of Research.....	412
	References .....	412

## Summary

Abiotic stresses are both serious in magnitude and widespread in occurrence and thus pose major hurdles to attaining higher crop productivity. In rice, salinity follows only drought stress in both extent and gravity. Tapping the potential of large salt-affected areas to increase rice production would contribute to food security and alleviate poverty in unfavorable rice growing environments where most resource poor farmers live. However, this would necessitate the development of salt tolerant varieties and their widespread adoption by farmers. Past progress in breeding new salt-tolerant varieties has been slow due to obvious reasons. Moreover, abiotic stresses seldom occur singly and are more severe when occur jointly. Progress, however, is being made in developing new salt tolerant genotypes using both conventional and non-conventional breeding methodologies. Robust screening techniques have been developed, the screening criteria and selection pressure are well elucidated, the genetics of salt tolerance are better understood and suitable genetic donors have been identified. Component traits for salinity tolerance are being pyramided, and recurrent selection methods such as the diallel selective mating are being employed to increase the frequency of the desired alleles in breeding populations specifically designed for deployment in specific target environments. Modern tools and techniques such as molecular marker-assisted selection is also being integrated into conventional breeding programs to increase the pace and efficiency of the varietal development process. Proven mechanisms of international collaboration are being harnessed to generate reliable research outputs while novel technology development and promotion approaches are employed to improve adoption levels and impact of new varieties. Various examples on these developments are provided in this chapter.

Keywords: breeding strategy • germplasm exchange • *Oryza sativa* • salt-stress • salinity screening



## I. Introduction

Plant abiotic stresses are external and nonliving factors that have harmful effects on plants. A non-living factor must exert influence on the normal range of environmental variation to adversely and significantly affect the plant performance or the physiology of the organism (Vinebrooke et al. 2004). Abiotic stresses are the most harmful factors affecting the growth and productivity of crops worldwide (Gao et al. 2007; Witcombe et al. 2008), resulting in a yield reduction ranging from 10% to 100% (Wang et al. 2007). They are most harmful when occurring together with other abiotic stresses (Mittler 2006) and their effect in yield will only worsen with the climatic changes expected in the future (Lane and Jarvis 2007).

The most important abiotic stresses affecting crop plants are drought, salinity and alkalinity, floods or excess water, extreme temperatures, mineral toxicities and deficiencies, high or low pH, poor edaphic conditions and high winds causing rapid dehydration during seed germination. Distinct varietal differences for each of these stresses have been reported for most crops, particularly for rice (Akbar and Yabuno 1972; Ikehasi and Ponnampereuma 1978; Mahadevappa et al. 1979; Fageria and Barbosa 1982; Camargo 1984; Yeo and Flowers 1984; Fageria 1985; Yeo et al. 1990; Yeo 1992; Zeng et al. 2002; Singh et al. 2002; Yeo and Flowers 2006; Rahman et al. 2007).

Abiotic stresses tend to be complex. Drought stress, for example, has no generally accepted definition because of its location- and land-use-specificity. Agricultural drought, for instance, may be different from hydrological drought (Bonacci 1993; Lilley and Ludlow 1996). At its simplest level, drought is the shortage of water in the system

*Abbreviations:* CEC – cation exchange capacity; CSSRI – Central Soil Salinity Research Institute; DS – dry season; DSMS – diallel selective mating system; EBT/P – ear bearing tillers per plant; ECe – Electrical Conductivity of saturated soil extract; ESP – exchangeable sodium percentage; HYVs – high-yielding varieties; INGER – International Network for Genetic Evaluation of Rice; IRRI – International Rice Research Institute; MAGIC – multiparent advanced generation intercrosses; MAS – marker-assisted selection; MTI – mean tolerance index; QTLs – quantitative trait loci; PVS – participatory varietal selection; RH – relative humidity; RI – response index; SES – standard evaluation system; SRI – stress resistance index; WS – wet season

concerned. Excess water-related stresses, on the other hand encompass rainfed lowland, deep water, submerged, floating, and tidal wetland conditions. Salinity relates with excess of the soluble salts in soil that are mostly chloride and sulfates of sodium. Soils with more than 4 dSm<sup>-1</sup> are categorized as saline soils. Major mineral toxicities or deficiencies such as those involving iron, boron, zinc, phosphorus, and sulfur seldom occur in isolation. How to combat this complex problem? In this review, we limit the discussion to salinity stress, one of the major abiotic stresses, with special reference to the development of rice (*Oryza sativa* L.) varieties to cope-up with the salinity problem.

## II The Need for Abiotic Stress-Tolerant Cultivars

Population growth has been the major driver behind efforts to increase the productivity of crop cultivars. During the nineteenth and twentieth centuries, world population increased at high rates, nearing 1.7 billion by 1900 and reaching 6 billion by 2000. It is expected to rise to nearly 8 billion by 2025 and 9.3 billion, or 150% of today's total, by 2050 (US Census Bureau 1998). Increased crop productivity would have to come from the world's arable land, which has not increased to a similar proportion as world population. From 1.277 billion ha in 1960, arable land increased to only 1.345 billion ha in 1980 and to just 1.397 billion ha in 2000. Because of urbanization and water scarcity, the expansion of land use for food production has almost stagnated and has shown a downward trend for many important crops with high input requirements, including rice. Although world cereal production increased from 876.8 million tons in 1960 to 2.06 billion tons in 2000 (FAO 2006) and rice production increased about three times from 200 million tons in 1960 to about 600 million tons in 2000, land cultivated for rice has not increased substantially (Maclean et al. 2002). Thus, the challenge to produce more food for a rapidly increasing population using either the same or shrinking cultivated area is an uphill task.

About 90% of the world's rice is produced in Asia – the continent where the crop is the most important staple food, which is home to most of the world's poor and has one of the world's highest population growth rates. The possibilities

for rice area expansion in most Asian countries, however, are almost exhausted. To produce more rice, three options remain: expand irrigated areas or favorable environments with high productivity, increase the productivity of rice in unfavorable ecosystems, and harness unfavorable areas with potential for food production. The first option is quite unlikely due to the increasing competition for irrigation water from urban and industrial users. For both of the last two options, the availability of high-yielding and abiotic stress-tolerant crop varieties becomes imperative. Hence, breeding efforts for abiotic stress-tolerant cultivars need to be initiated, strengthened, and sustained.

Estimates of salt-affected areas range from 0.34 to 1.2 billion ha globally (Massoud 1974; Ponnampuruma 1984; Tanji 1990; FAO Database 2008). Salt stress seldom, however, occurs in isolation and is always coupled with mineral deficiencies and toxicities, which compound the problem (Gregorio et al. 2002; Singh et al. 2004; Ismail et al. 2007). Examples of associated soil stresses are Zn deficiency, Fe toxicity, P deficiency and submergence. Thus, in breeding rice for saline environments, multiple abiotic stress tolerance must be considered. Fortunately, rice has enormous variability for tolerance towards most abiotic stresses.

Rice is the only economic crop that can grow well in waterlogged environments while tolerating salinity up to a certain extent. The crop can be grown in coastal belts that are always prone to inundation by sea water during high tides, resulting in salinization. Under these conditions, only salt- and submergence-tolerant crops are economically viable farming options. In tropical and subtropical areas, only rice adapts and grows well. Soil sodicity is the other kind of soil problem in which high salt concentration is compounded by low infiltration rate and poor hydraulic conductivity. This brings about water stagnation on the soil surface, which in turn does not allow any crop except rice to survive. Hence, rice is recommended as the first crop to be planted during reclamation of sodic soils.

The enormous potential negative impact of climate change on the world's major food crops, including rice, is also increasingly recognized. Global temperatures, for example, are estimated to rise between 1.1°C and 6.4°C during the next century (IPCC 2007), threatening rice production

in some of the most productive rice areas of the world, such as those in India and Pakistan. These increased temperatures will also disrupt weather patterns, leading to increasingly regular occurrence of floods, drought, and salinity. Melting ice caps and glaciers, for example, are expected to cause a rise in sea level (National Geographic Channel 2008; Wassmann et al. 2004; Mellouland and Collin 2006), leading to increased coastal salinity and further yield reduction, even in previously favorable areas. This may imperil the food security for millions of people, mostly the resource-poor.

### III Past Breeding Efforts

The contribution of modern plant breeding to food security and poverty alleviation is well recognized. The development and dissemination of high-yielding rice varieties (HYVs) that were semi-dwarf, N-responsive, and resistant to biotic and abiotic stresses in the 1960s, for example, triggered the green revolution in India that increased rice production at an annual rate of 2.4% (Singh 1999). Evenson and Gollin (1997) noted that, if not for the development of HYVs, between 1975 and 1995, rice prices would have increased by 41%, rice imports by 8%, and malnutrition by 1.5–2%, and millions of hectares of forests and fragile ecosystems would have been converted into rice areas. Moreover, the shift from traditional to modern varieties by farmers increased their rice yields by 2.1 t ha<sup>-1</sup>, on average, and resulted in an annual benefit estimated at US\$10.8 billion (Hossain et al. 2002).

The varietal development program for salt tolerance in rice has progressed very slowly worldwide because: (a) the ecosystem involves a very harsh and wide-ranging environment – from barren sodic to coastal saline soils with huge temporal and spatial variability; (b) the genotype × environment (G × E) interaction is high, making the assessment of the true worth of a genotype very difficult; (c) precise and repeatable phenotyping or screening facilities are lacking; (d) knowledge about the mechanisms for salt tolerance is lacking or at best limited; and (e) the human and logistical resources allocated for salinity research are limited due to low prioritization relative to other ecosystems.

*Table 1.* Traditional landraces and subsequent selections adapted to salt-affected soils in India.

Landraces	Selection (local variety)	State	Area of adaptation
Jhona	Jhona 349	Punjab	Sodic soils of Punjab and Haryana
Chaul local	T 21	Uttar Pradesh	Sodic soils of Uttar Pradesh
Kashi	Lakra or T 22A	Uttar Pradesh	Sodic soils of Uttar Pradesh
Kalambank	SR 26B	Orissa	Coastal saline soils of east coast
Local collections	SR 8	Orissa	Coastal saline soils of Orissa
Local collections	Raspanjore	Orissa	Coastal saline soils of Orissa
Budda Mologolakulu	MCM 2	Andhra Pradesh	Coastal saline soils of Andhra Pradesh
Local collections	Kalar samba	Tamil Nadu	Coastal saline and sodic soils of Tamil Nadu
Local collections	Kallimadyan	Tamil Nadu	Coastal saline and sodic soils of Tamil Nadu
Local Rata	Kala Rata 1-24	Maharashtra	Coastal saline soils of Maharashtra
Local Rata	Bhura Rata 4-10	Maharashtra	Coastal saline soils of Maharashtra
Patnai	Patnai 23	West Bengal	Coastal saline soils of West Bengal
Patnai	Patnai 298	West Bengal	Coastal saline soils of West Bengal
Damodar	CSR1	West Bengal	Coastal saline soils of West Bengal
Dasal	CSR2	West Bengal	Coastal saline soils of West Bengal
Getu	CSR3	West Bengal	Coastal saline soils of West Bengal
Benisail	Matla	West Bengal	Coastal saline soils of West Bengal
Nona Bokra	Hamilton	West Bengal	Coastal saline soils of West Bengal
Local collections	Velki (Bhaluki)	West Bengal	Coastal saline soils of West Bengal & Orissa
Local collections	Rupsal	West Bengal	Coastal saline soils of West Bengal
Nonasail	CSR 6	West Bengal	Coastal saline soils of Orissa and WB
Arya	Arya 33	Karnataka	Saline and sodic soils of Karnataka
Karekagga	Ankola	Karnataka	Saline and sodic soils of Karnataka
Local collections	Pokkali	Kerala	Coastal saline soils of Kerala
Chettivirippu	Mo 1	Kerala	Coastal saline soils of Kerala
Kalladachampavu	Mo 2	Kerala	Coastal saline soils of Kerala
Kunjathikkara	Mo 3	Kerala	Coastal saline soils of Kerala
Chottupokkali	Vytila 1	Kerala	Coastal saline soils of Kerala
Local collections	Korgut	Goa	Coastal saline soils of Goa
Local collections	Azgo	Goa	Coastal saline soils of Goa

Taking the example of India, the development of salt-tolerant rice varieties dates back to the 1940s when varieties such as Pokkali and Jhona 359 were developed through systematic selection under coastal saline and inland saline-sodic soils, respectively. Most of the earlier varieties, however, were selections from the locally adapted cultivars that had been grown for ages in the target environments. A majority of these were from the coastal belt, where the salinity problem was both endemic and perpetual and where farmers did not have too many options except to grow rice out of compulsion. A few examples of the early selections from the local types/landraces are given in Table 1. More recently, some of these selections were released by different states although most

of them remained as selections with very specific and small growing areas.

Crosses made involving some salt-tolerant landraces or their selections before 1970s have led to development of varieties. However, the resulting varieties were not accepted by farmers at large, because of their insufficient level of salt tolerance and/or poor/unacceptable grain quality. Moreover, the linkage drag involved in the use of local traditional types with very tall stature, non-responsiveness to fertilizer, and poor grain quality in these crosses was large (Table 2). Lately, however, several national rice research programs have successfully developed better adapted and high yielding salt-tolerant rice varieties.

Table 2. Salt-tolerant rice varieties evolved through recombination before the 1970s

Variety	Parentage	Institution
PVR 1	MTU 1/SR 26B	Rice Research Station, Peravoorani, Tamil Nadu
MCM 1	CO 18/Kuthir	Rice Research Station, Machlipatnam, Andhra Pradesh
MK47-22	Malkudai/KR 1-24	Kharland Research Station, Panvel, Maharashtra
SR 3-9	KR 1-4/Zinnya 149	Kharland Research Station, Panvel, Maharashtra
MR 18	SR 26B/Wannar-1	Rice Research Station, Mandya, Karnataka

#### IV Limits of Plant Stress Tolerance

Plant stress tolerance varies greatly within and between different plant families and crops.

##### A Intercrop Variability

Some plant families have more salt-tolerant species than others. For example, the family *Chenopodiaceae* has many salt-tolerant species (*Salicornia* and sugarbeet), whereas the family *Leguminosae* comprises mostly salt-sensitive pulses. The *Graminea* family, one of the most important for human existence, also has many salt-tolerant genera. Maas and Hoffman (1977) categorized rice as a moderately salt-sensitive crop and explained its degree of tolerance based on salinity response curve. This response curve was proposed for the yield vs. salinity response and represented by two linear lines. One is a

tolerance plateau with a slope of zero and other a concentration dependent line whose slope ( $b$ ) indicates the yield reduction (%) per unit increase in salinity. The first part i.e. tolerance plateau indicates the threshold salinity ( $a$ ) in  $\text{dSm}^{-1}$  and the second part, for soil salinities ( $\text{EC}_e$ ) exceeding the threshold of any given crop, indicates about the relative yield ( $Y_r$ ) with the help of a simple linear equation i.e.  $Y_r = 100 - b(\text{EC}_e - a)$ . In many laboratories, a 50% reduction in productivity over non-stress is also considered as the limit of tolerance for salinity and alkalinity for different crops. This yardstick has been used extensively in field and artificially created controlled environments in pots and microplots (Mishra 1996) to determine crop salt tolerance. The tolerance limits of some important crops are shown diagrammatically in Fig. 1.

##### B Intracrop Variability (Intervarietal/Genotypic Tolerance)

Success of any breeding program mainly depends upon the range of intracrop variability available for the desired trait. Response to selection and genetic advance is possible only if considerable variability exists. Maas and Hoffman (1977) divided different crops into four categories (tolerant, moderately tolerant, moderately sensitive and sensitive) based on the performance of one or a few genotypes/varieties. They did not evaluate the variability existing within a crop to determine the threshold value, slope, and relative salt tolerance. For example, rice has tremendous variability for salinity as well as sodicity; hence, to categorize the whole crop with enormous variability as a sensitive crop may not be a truly meaningful inference since rice gene banks hold

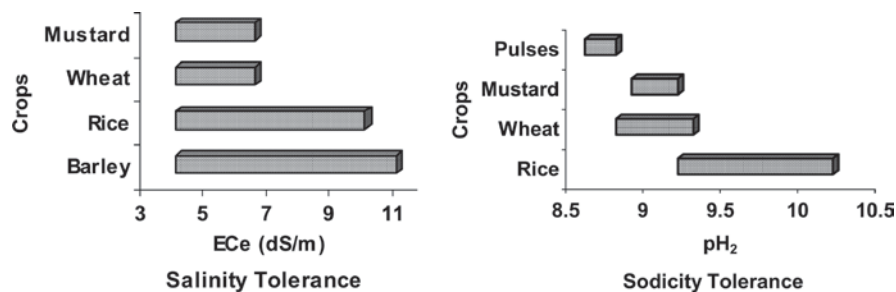

Fig. 1. Range of variability for salinity/sodicity tolerance in important crops (Adapted from Mishra 1996).



tens of thousands of accessions from around the world having huge variability in stress tolerance. Indeed, the threshold limit that is defined as the lowest stress level at which a significant yield reduction starts depends upon the inherent tolerance of the genotype. It would be quite different for two genotypes with contrasting traits such as rice varieties Pokkali (highly tolerant to salinity) and IR29 (extremely sensitive to salinity). Rice has the maximum range of genetic variability for alkalinity tolerance, whereas barley has the maximum range for salinity tolerance (Fig. 1).

## V Breeding Salinity Tolerance with High Yield

A successful breeding program should have: (a) a wide spectrum of genetic variability for the desired trait (good donors), and (b) a robust, repeatable, and reliable screening technique. Though screening

techniques usually vary with growth stage and the type of stress imposed, an ideal technique should be rapid, reproducible, easy to use, and affordable. In most breeding programs, tolerance to salinity and other abiotic stresses is considered as a single trait, which should not be so. Indeed, a phenotype with tolerance or sensitivity is the overall manifestation of the sum of the different tolerance mechanisms operating in the genotype. Invariably, however, the component traits responsible for stress tolerance, such as  $\text{Na}^+$  exclusion, tissue tolerance, or  $\text{K}^+$  uptake, are quantitative traits governed by many genes. It is difficult to pool even two polygenic traits together and the integration of a set of quantitative traits ( $\text{Na}^+$  exclusion and  $\text{K}^+$  uptake) with another set of quantitative traits (grain yield components) into one background is a real challenge for plant breeders, as depicted in Fig. 2. The major hurdles to surmounting this challenge are: (a) the lack of a proper mechanistic understanding for each trait;

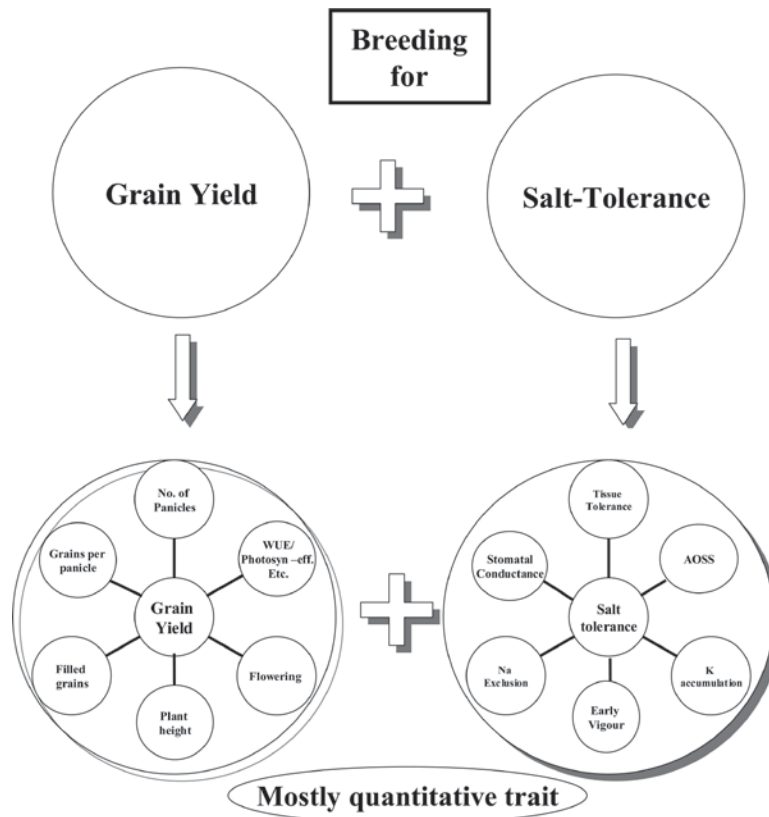

Fig. 2. The challenge of integrating quantitatively inherited characters into one genetic background.

Table 3. Probability of the desired recombinants

Generation	Number of gene(s) responsible for a trait (n)/genotypic classes			
	1	2	5	10
F <sub>2</sub>	1:2:1	1:2:1:2:4:2:1:2:1	243 classes	59,049 classes
F <sub>3</sub>	3:2:3	3:2:3:6:4:6:3:2:3		
F <sub>4</sub>	7:2:7	7:2:7:14:4:14:7:2:7		
F <sub>5</sub>	15:2:15	15:2:15:30:4:30:15:2:15		
F <sub>6</sub>	31:2:31	31:2:31:62:4:62:31:2:31		
P*	1/4	1/16	1/1,024	1/1,084,576

\*P is the probability of getting the desired homozygote at all the loci in the smallest perfect population in F<sub>2</sub> (1/4<sup>n</sup>).

If trait A = 5 loci, desired recombinant probability = 1/1,024.

If trait B = 10 loci, desired recombinant probability = 1/1,084,576.

Probability of getting both desired recombinants in one background = 1/1,024 × 1/1,084,576 = 1/1,110,605,824 (>1 billion).

and (b) the lack of precise screening techniques for all the component traits.

The question is how to obtain a desirable genotype? What would be the probability to obtain such a genotype? If one gene is controlling the trait, then the probability of obtaining the desired genotype would be one out of four in the minimum perfect population. As the number of genes controlling the trait increases, this probability declines sharply. A trait controlled by two genes will have a probability of one out of 16 to get the desired recombinant. Similarly, traits governed by five and ten genes would need a minimum perfect population of 1,024 and >1 million, respectively, to get just one desired genotype with all the positive alleles (Table 3). Let us take one hypothetical example considering two quantitative traits for which one contributing trait conferring salinity tolerance (such as Na<sup>+</sup> exclusion) is governed by five genes and another trait, such as K<sup>+</sup> uptake, is governed by ten genes. The probability of getting the most desirable genotype with all 15 positive alleles would be one out of >1 billion, thus requiring a plant population that would be almost impossible to handle and from which to select that one individual, in practical terms. The area required for a population of this size, for example, would be around 4,442 ha at a plant-to-plant spacing of 20 × 20 cm. Because of such a low probability of selecting the desired recombinant with all 15 positive alleles, recurrent selection is followed. This involves sequential mating of selected individuals to increase the probability of obtaining the desired recombinant at one in

a few thousand rather than one in a billion or more plants.

Another complexity associated with breeding for quantitative characters is the rate of approach to homozygosity, which is reduced by an increase in the number of loci involved in the inheritance of a trait. It takes more generations of selfing to obtain homozygous lines if more loci are involved. Most plants reach homozygosity by the F<sub>7</sub>–F<sub>9</sub> generation if a few loci are involved, while it takes up to F<sub>12</sub>–F<sub>14</sub> generations of selfing for homozygous lines to be obtained when more loci are involved, as seen in Table 4.

## VI The Concept of Heritability

Before discussing heritability and breeding methodology, it is important to return to the most basic yet most important concepts of genotype and phenotype in plant breeding, which date back to Johanssen (1903).

Heritability revolves around two basic points:

- Genes cannot push a trait to develop unless the appropriate environment is provided, i.e., genes for biotic and abiotic stresses will not express unless the genotype is exposed to the appropriate stress environment.
- No amount of manipulation of an environment can cause a phenotype to develop unless the necessary genes are present, e.g., a rice variety with genes for a white stigma cannot be converted into a variety with a purple stigma by changing its growing environment or nutrition or both.

Table 4. Approach to homozygosity with different numbers of loci underlying a trait(s)

Values of homozygosity ( $P$ ) = $[1 - (1/2)^{g-1}]$ for representative generations (g) and representative numbers of loci													
Generations (g = 0 in $F_1$ and g = 13 in $F_{14}$ )													
Loci	$F_2$	$F_3$	$F_4$	$F_5$	$F_6$	$F_7$	$F_8$	$F_9$	$F_{10}$	$F_{11}$	$F_{12}$	$F_{13}$	$F_{14}$
1	0.50	0.75	0.88	0.94	0.97	0.98	0.99	–	–	–	–	–	–
2	0.25	0.56	0.77	0.88	0.94	0.97	0.98	0.99	–	–	–	–	–
3	0.125	0.42	0.70	0.77	0.91	0.95	0.98	0.99	–	–	–	–	–
5	0.0313	0.24	0.51	0.72	0.85	0.92	0.96	0.98	0.99	–	–	–	–
10	–	0.06	0.26	0.52	0.77	0.85	0.92	0.96	0.98	0.99	–	–	–
20	–	–	0.07	0.28	0.53	0.73	0.86	0.92	0.96	0.96	0.99	–	–
50	–	–	–	0.04	0.20	0.46	0.68	0.82	0.90	0.95	0.98	0.99	–
100	–	–	–	–	0.04	0.20	0.46	0.68	0.82	0.90	0.95	0.98	0.99
150	–	–	–	–	0.01	0.05	0.31	0.56	0.74	0.86	0.93	0.97	0.99

“–” indicates frequency <0.01 or >0.99.

Source: Allard (1999).

Table 5. Relationship used to explain the estimation of heritability.

Increase in the number of variables	Resources required	Precision of heritability estimates increased by adding one additional variable
Replication (r)	Relatively less	Little increase
Location (L)	Relatively more	High
Year (Y)	Higher	Very high

Heritability is of two kinds:

- Broad-sense heritability or the ratio of genotypic vs. phenotypic variance =  $\sigma_G^2/\sigma_P^2$  and denoted by  $H$ .
- Narrow-sense heritability or the ratio of additive vs. phenotypic variance =  $\sigma_A^2/\sigma_P^2$  and denoted by  $h^2$ .

Heritability is responsible for the resemblance among relatives due to the transmission of traits from parents to offspring and also for accuracy of the prediction of the genetic gain from the selection. However, heritability estimates are always based on the target population in both space and time, and the environment where it is estimated. These estimates can be biased upward because of:

- Genetic factors: it is difficult to separate out the epistatic (non-allelic) factors (e.g., additive  $\times$  additive) from the allelic interactions
- Environmental factors: it is difficult to separate out the environmental effects from the true genetic effects and plant breeders try to minimize errors by replicating (r) the materials and growing them at different locations (L) and/or for several seasons/years (Y)

Therefore, the precision for the estimation of the heritability of a trait could be improved by increasing the number of replications, locations, and/or years of testing so that the total genetic variance can be partitioned into variances due to genotype, variances due to environmental factors (L, Y), and genotype  $\times$  environmental interactions ( $G \times L$ ;  $G \times Y$ ;  $G \times L \times Y$ ). Although it is theoretically possible to keep increasing these environmental factors by partitioning the total variance to improve precision of the estimates of true genetic worth, this is difficult to do in practice since each additional replication, location, and year correspondingly increases the experimental costs. Thus, to get more reliable estimates of the heritability, a compromise between resources and the experimental parameters needs to be made. Since salinity is highly variable in the soil because of the dynamic state of soluble salts, more blocks at different locations over the years in accordance with a judicious use of available resources are recommended for the precise estimation of heritability. This can be explained through the relationship explained in Table 5.

Many researchers prefer the concept of genetic advance under selection ( $G_s$ ) over heritability as a genetic parameter because it gives the estimates of attainable progress in practical units of measurement (such as kg/year). Genetic advance depends upon broad-sense heritability (H), phenotypic variance and standardized selection differential (k). The selection differential is a constant factor derived from the selection intensity applied to a normally distributed population, that is,  $k = 2.64$ , if 1% of plants are selected from the population and  $k = 2.06$  and  $1.76$  for 5% and 10% selection intensity, respectively.

The interrelationships of these parameters can be expressed as follows:

- $G_s = k \cdot \sqrt{\sigma_p^2} \cdot H$  = selection differential  $\times$  phenotypic standard deviation  $\times$  heritability
- $G_s = k \cdot \sqrt{\sigma_p^2} \cdot \sigma_g^2 / \sigma_p^2 = k \cdot \sigma_p \cdot \sigma_g^2 / \sigma_p^2$
- $G_s = k \cdot \sigma_g \cdot \sqrt{H}$  = selection differential  $\times$  genotypic standard deviation  $\times$  square root of heritability

It is evident that to obtain accurate heritability estimates in abiotic stress tolerance breeding, precise phenotyping is required to reliably select the tolerant plants from the population for selective intermating following recurrent selection.

## VII Genetics of Salt Tolerance

### A Inheritance Studies

The first reports on inheritance of salt tolerance came from Akbar And Yabuno (1972, 1975, 1977), in which it was inferred that inheritance of panicle sterility under salinity stress is controlled by a small number of dominant genes, but their studies were not extended to later-segregating generations. Most inheritance studies indicated a normal distribution of the trait in different populations, indicating its polygenic inheritance. Moeljopawiro and Ikehashi (1981) did one of the earliest studies in rice using two crosses between two moderately tolerant parents and between two tolerant parents rather than the contrasting parents. They found a low genetic response to selection as indicated by a low but significant repeatability of 0.20–0.25. A high degree of environmental fluctuations was also noticed. Another inherit-

ance study for salinity tolerance in rice by Mishra et al. (1998) also inferred polygenic inheritance. They phenotyped  $F_1$  and bulked  $F_3$  generations of three crosses between two tolerant parents (CSR10 and CSR11) and two sensitive parents (Basmati 370 and Pakistani basmati) under an artificially created saline soil environment (ECe 10 dSm<sup>-1</sup>) in lysimeters. All the  $F_3$  plants, scored based on the IRRI SES at the adult stage, showed continuous variation, with little skewness, suggesting the role of a few major genes along with numerous minor genes in the inheritance of salinity tolerance. It was also inferred that the salinity tolerance trait also lacked maternal influence. A similar inheritance study for sodicity tolerance was conducted involving the same populations. Results indicated that sodicity tolerance is also a polygenic trait acting both additively and with interactions between the alleles at some loci (Singh et al. 2001).

### B Association Studies

Association studies are important for indirect selection for a desired trait(s) using associated traits if phenotyping of the latter is relatively easy. The association could mainly be due to two reasons: either the traits are closely linked or the gene has pleiotropic effects. Salt stress affects most growth parameters; therefore, by selecting the most closely associated trait, a desirable genotype can be selected. An altered effect due to salt stress is much more evident in salt-sensitive genotypes than in tolerant ones. Therefore, traits such as the proportion of filled/unfilled grains, degree of deviation for grains per panicle, spikelet fertility, plant height, fertile tillers and flowering in comparison to non-stress are good indicators for selecting tolerant genotypes. In one association study on 15  $F_1$  populations, grain yield was highly and positively correlated with filled grains per plant, filled grains per panicle, panicle weight, K content, and 100-grain weight but had a strong negative correlation with percent spikelet sterility and reproductive-stage salinity tolerance score, which is highly desirable (Mishra 1994). Gupta (1999) also studied the relationship between eight traits (plant height, days to 50% flowering, EBT/P, number of filled grains per plant, grain yield per plant, Na<sup>+</sup>, K<sup>+</sup>, and Na<sup>+</sup>/K<sup>+</sup>



ratio) under salt-stress environments. The role of  $\text{Na}^+$  and  $\text{K}^+$  became apparent from the study as grain yield correlated negatively with Na content as well as  $\text{Na}^+/\text{K}^+$  ratio, whereas it had a positive correlation with  $\text{K}^+$  content under both alkali and saline soil conditions.

### C Gene Action and Heritability

Initial diallel studies on salinity tolerance in rice revealed the presence of both additive and non-additive gene action for almost all the characters associated with salt tolerance (Akbar et al. 1985; Moeljopawiro and Ikehishi 1981; Gregorio and Senadhira 1993; Mishra et al. 1996). Gupta (1999) reported genetic parameters following Hayman's method for various traits under saline and sodic environments in rice in a  $6 \times 6$   $F_1$  diallel. Almost all the studied traits showed significance of additive as well as non-additive gene action. The average dominance was within the range of complete dominance to overdominance as degree of dominance was mostly more than one (Table 6).

There are different reports on narrow-sense heritability estimates. Gregorio and Senadhira (1993) reported high environmental effects with low narrow-sense heritability estimates for low  $\text{Na}^+/\text{K}^+$  ratio in a  $9 \times 9$  diallel in rice. However Mishra et al. (1990) and Gupta (1999) reported a high magnitude of narrow-sense heritability for  $\text{Na}^+/\text{K}^+$  ratio for both alkali (0.658) and saline soils (0.630) and for grain yield (0.547 in alkali soils and 0.569 in saline soils) (Table 6). If the narrow-sense heritability is low, early-generation population size should be large; replications and locations over years should be increased, if possible, to screen the right genotypes; and

selection should be done in the later generations. However, if the trait associated with salt tolerance has high narrow-sense heritability, then early selection could be practiced.

### D Combining Ability Analysis

Gregorio and Senadhira (1993) showed the significance of both general combining ability (gca) and specific combining ability (sca) for salinity tolerance in rice. They also found that moderately tolerant plants (IR4595-4-1-13 and IR9884-54-3-1E-P1) were the best combiners for salt-tolerant progenies. They also found significant reciprocal effects that indicate the role of maternal inheritance. Mishra (1991) reported that salt-tolerant rice varieties CSR10 and CSR1 were good combiners for salt-tolerance contributing traits. Gupta (1999) also reported the preponderance of both gca and sca effects, but their ratio (Table 6) suggested a higher degree of dominance variance.

### E Heterosis

To exploit hybrid vigor in rice, heterosis on the order of 20–50% over the best variety (standard variety) could compensate for the cost of hybrid seed. Hybrid rice appears to be an alternative for favorable environments for a further breakthrough in yield potential. Moreover, at IRRI, hybrids have been observed to also perform far better under moderate stress because of hybrid vigor. A few reports, especially from Egypt, have substantiated the heterosis concept in saline soils (Virmani 2002). Another study undertaken by Gupta (1999) at the Central Soil Salinity

Table 6. Estimate of genetic parameters for various traits under saline and sodic soil environments in a  $6 \times 6$  diallel.

Genetic parameters	Genetic estimates							
	No of filled grains/panicle		Spikelet sterility		Grain yield/plant		Na/K ratio	
	Saline	Sodic	Saline	Sodic	Saline	Sodic	Saline	Sodic
Degree of dominance ( $(H_1/D)^{1/2}$ )	1.584	1.226	2.234	1.178	1.538	1.288	1.540	0.952
Heritability in narrow sense ( $h_{ns}^2$ )	0.573	0.567	0.474	0.629	0.569	0.547	0.630	0.658
GCA/SCA	0.449	0.417	0.192	0.686	0.440	0.372	0.564	0.759

Source: Adapted from Gupta (1999).

Research Institute (CSSRI) in India showed significant heterosis over the mid- and better parent for almost all characters studied. Grain yield is the prime concern of breeders. Out of 15  $F_1$  crosses, Pokkali  $\times$  IR28 (79.87%), CSR10  $\times$  IR28 (67.18%), CSR13  $\times$  IR28 (54.58%), and CSR1  $\times$  IR28 (48.56%) had a positive and significant heterotic response over the mid-parent, whereas Pokkali  $\times$  IR28 (49.31%) exhibited heterosis over the better parent in alkali soil. On the other hand, the crosses CSR13  $\times$  IR28 (35.17%) and CSR10  $\times$  CSR13 (26.72%) gave heterotic responses over the mid-parent and only one cross, CSR10  $\times$  CSR13 (24.53%), performed better than the better parent in saline soil.

## VIII Breeding Methodology

### A Conventional Approaches

#### 1 Selection and Introduction

Breeding for any trait starts with the assembly of genetic variation through the collection and evaluation of the available germplasm. If the desired variability is not available within a locality or species, introduction of the exotic germplasm can be resorted to. This classical approach is still very relevant in all breeding strategies. Few varieties with salinity tolerance have been developed worldwide using selection and introduction approaches. The salt-tolerant rice varieties Damodar (CSR 1), Dasal (CSR 2), and Getu (CSR 3) were pure-line selections from local salt-tolerant traditional cultivars prevailing in the Sunderban areas in West Bengal. Similarly, Jhona 349, SR26B, Bhura rata 4-10, Patnai 23, Hamilton, and Vytilla 1 were also very site-specific selections from landraces.

In the mid-1970s, attempts were made to transfer the salinity tolerance from highly tolerant traditional varieties such as Pokkali and Nona Bokra to an improved genetic background but the recombinants generated were either not equally tolerant or carried many linked undesirable traits from donors. However, with the development of better screening techniques in the late 1980s, many salt-tolerant rice varieties in improved backgrounds were developed in different countries following recombination breeding (Gregorio et al. 2002) as discussed in subsequent sections.

#### 2 Pedigree Method

This is a classical method in which the lineage of the plant selection in the segregating generation is maintained until it is stabilized in the  $F_7$  or  $F_8$  generation. But, due to cumbersome procedures and the involvement of more resources, breeders are modifying this method and not adhering to it strictly.

#### 3 Modified Bulk Pedigree Method

A combination of pedigree and bulk breeding methods, this is almost as effective as the pedigree method, with relatively less use of resources. It has flexibility and is useful for less heritable traits, with the individual  $F_2$  plants harvested in bulk up to the  $F_4$  or  $F_5$  generations, followed by panicle selection and handling of the population as in the pedigree method. However, for highly heritable traits, the individual plants are selected in the earlier generations ( $F_2$  or  $F_3$ ), followed by bulking for a few generations and ultimately single-plant or panicle selection in the  $F_5$  or  $F_6$  generation. The schematic diagrams for the modified bulk pedigree method applied for salt tolerance breeding at IRRRI are shown in Fig. 3.

#### 4 Shuttle Breeding

Since most abiotic stresses are very location-specific, the varieties developed need to fulfill specific plant-type requirements. In the shuttle breeding approach, prebreeding or advanced breeding materials are evaluated at different locations for their adaptability and the best adapted materials are again crossed and evaluated at different target sites in replicated trials. The latter step functions like the multilocation testing of advanced breeding materials. The salt-tolerant rice varieties CSR23 and CSR27 were developed through a shuttle breeding approach under an ICAR-IRRI collaborative project for salt tolerance (Mishra 1994).

#### 5 Mutation Breeding

This method was followed for the development of the first salt-tolerant rice variety, CSR10. The female parent of variety M40-431-24-114 was derived from  $\gamma$  ray-irradiated (10 kR)  $F_1$  seed of the cross CSR1/IR8. This female parent was crossed with Jaya and the progeny was handled as in the pedigree method.

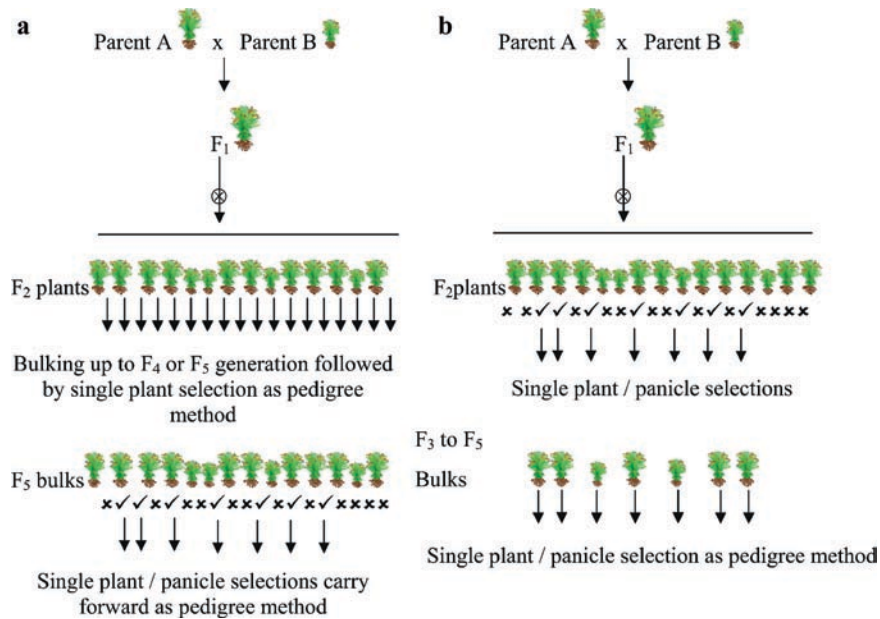

Fig. 3. Diagrammatic presentation of the modified bulk method (a) for low-heritability traits and (b) high-heritability traits.

### 6 Diallel Selective Mating System Supplemented by MAS

The biggest bottleneck in breeding for self-pollinated crops is the narrow genetic background in the resulting progenies as breeders can exercise parental control on only two individuals for a single cross, on three for a three-way cross, and at the most four for a double cross. To increase parental control, broaden the genetic base, and break up linkage blocks, IRRI is employing a diallel selective mating system (DSMS), which is modified from the DSMS suggested by Jensen (1970). This modified DSMS becomes a permanent breeding scheme for developing multiple abiotic stress-tolerant genotypes with wide adaptability (Fig. 4). Basically, it is a type of recurrent selection scheme in which only the desired alleles (selected genotypes) are advanced further for selective intermating. The philosophy behind this scheme is the “recurrent selection of the desired genotypes” and “intensive crossing among the selected genotypes” so that the probability of getting the desired recombinant genotypes becomes high. The major goals of this long-term breeding strategy are to develop genetic materials with multiple abiotic stress tolerance, break up

the very tight linkage blocks common in self-pollinated crops such as rice, maximize the chances that only the desired gene frequencies are forwarded to subsequent generations, tap germplasm donors available at IRRI from different geographical niches, and enable large-scale validation and use of marker-aided selection (MAS) in combination with conventional breeding. The target areas envisaged for the materials generated are submergence-prone coastal saline soils, inland salt-affected soils, Fe-toxic soils and Zn-deficient soils (Singh et al. 2006).

#### B DSMS Methodology

Donors identified for tolerance to various stresses along with good plant and grain types are used in breeding. To accommodate more diverse genotypes in the cross, a partial diallel method or cyclical crossing could be used in basic parental series ( $1 \times 2, 2 \times 3, \dots, n \times 1$ ). Although it is difficult to make many crosses in a self-pollinated crop such as rice, with the good crossing facilities at IRRI, half diallel sets without reciprocals [ $n \times (n - 1)/2$ ] can be generated to accommodate more parents in comparison to the use of a complete

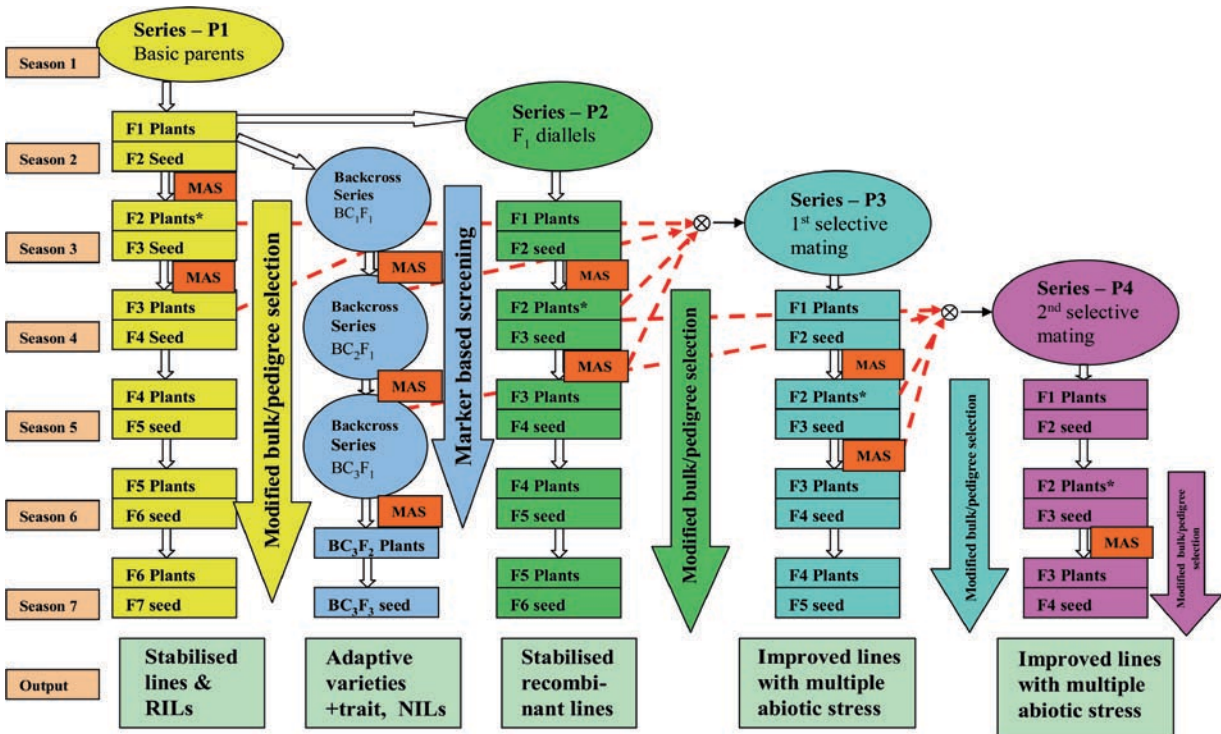

Fig. 4. Schematic diagram of the modified diallel selective mating system (DSMS) involving marker-assisted selection (MAS) (Adapted from Singh et al. 2008) [See Color Plate 10, Fig. 16].

diallel cross. Care should be exercised not to make more than 15 parental combinations; otherwise, the number of crosses to make would be astronomically high, from 105 (in a six-parent complete diallel) to 220 (in a seven-parent complete diallel) and so on, because, in an  $F_1$  diallel series, this would be difficult to manage. The segregating generations are screened for the various traits depending upon their donor parents and the most tolerant and desirable types are identified either through phenotyping or marker-aided selection before flowering, followed by intermating of the selected genotypes. This gives rise to the first selective intermating series. Similarly, the second selective intermating series could be generated depending upon the availability of resources. These selective mating series allow the advancement of only the desirable recombinants for them to be recombined again. In this dynamic series, one cycle follows another. One more cycle can also be added to develop specialized stocks such as mapping populations and also to add value to

well-adapted mega-varieties or varieties planted on more than a million hectares.

The modifications made to the original scheme include the (a) application of MAS in the  $F_2/F_3$  generations for specific traits; (b) introduction of an additional backcross series to convert mega-varieties/adapted varieties into improved versions with tolerance of abiotic stress; and (c) use of a modified bulk-pedigree method instead of mass selection to advance the generations.

Since IRRRI has standardized the MAS screening technique using flanking markers tightly linked to the submergence tolerance gene (*SUB1*) and *QTL* for salinity tolerance at the seedling stage (qSALTOL), it is now routinely used for the selection of desirable recombinants for selective mating (Singh et al. 2008a). However, phenotypic selection using natural or artificial stress is employed for other traits. The use of MAS will be extended to other traits such as reproductive-stage tolerance for salinity, Zn deficiency and Fe toxicity once major QTLs for these traits are identified.



## C Non-conventional Approaches

### 1 $F_1$ Anther Culture Technique

$F_1$  anther culture has the twin advantages of increasing speed and improving breeding efficiency. Thus, it has become an effective tool to attain homozygosity of recombinants within the shortest possible time. Following a conventional cross, it takes a minimum of four to five years before complete or 100% homozygosity is reached, as only two generations can usually be advanced in a single year. The use of anther culture overcomes this problem by regenerating  $F_1$  pollen into homozygous plants. The technique also offers the opportunity to screen haploid materials at the stage of tissue culture. This allows recessive mutants to be identified and a variety of selection pressures can be imposed. This approach was used at IRRI to develop salt-tolerant homozygous recombinants from diverse cross combinations. Anther culture derivatives generated at IRRI were also evaluated under the ICAR-IRRI collaborative network in India by CSSRI, which led to the identification of the promising rice varieties IR51500-AC-17, IR51485-AC-1, and AC6534-4 for salinity, AC6533-3 for sodicity, and AC6534-1 for dual tolerance (Singh et al. 1992; Singh and Mishra 1995). IR51500-AC-17 and AC6534-1 were developed and named as CSR 21 (IET no. 13558) and CSR 28 (IET no. 13560), respectively, in India. A breeding line derived from the anther culture of the cross IR51500 (IR51500-AC11-1) was also developed at IRRI (IRRI 113) and released as variety PSB Rc50 in the Philippines for saline-prone areas.

### 2 MAS and Transgenics

Both these techniques and their utilization in generating stress tolerant plants have been discussed in details in Chapters 19 and 20.

## IX Screening Methodology

### A Screening Techniques

#### 1 In-situ Field Evaluation

Field screening is the most ideal method for identifying adapted and tolerant genotypes because

salt tolerance is a complex phenomenon. However, spatial variability in the field makes escape possible and, hence, field screening becomes less reliable if proper care is not taken. Therefore, extensive field testing for soil salinity gradient and appropriate blocking with a sufficient number of replications are the best ways to minimize experimental error. To reduce the effect of spatial variability, genotypes are usually screened using two to five rows, 6–20 m long, with space planting, depending upon the type and generation stage of the material. This allows maximum possible exposure of all genotypes to varying soil sodicity conditions. The layout for such a test involving many genotypes generally follows an incomplete block design, alpha lattice or augmented design in which a set of check varieties is replicated many times. This increases the potential number of test varieties, thus allowing the screening of a large number of genotypes at the same time. The use of more checks improves data processing and analyses and, ultimately, the selection of tolerant lines. Selected genotypes are then further evaluated in on-station trials that use bigger plots for evaluating their yield potential.

#### 2 Screening in Microplots

Soil heterogeneity and spatial variability could mask the true response of genotypes, thus the need to measure genotypic response in a dependable way. This can be achieved using microplots (also called lysimeters), which are like mini-fields in dug-out concrete tanks filled with artificially prepared or natural soil transported from affected areas and with varying amounts of desired salinity and sodicity. This kind of facility has been built at CSSRI, Karnal, India, using brick-mortar-concrete materials measuring 2 m × 2 m or 6 m × 3 m with a depth of about 0.8 m and 1 m, respectively. These microplots are filled with artificially prepared soil that is uniform throughout the profile. Desired levels of sodicity ( $\text{pH}_{1,2} = 9.0, 9.6,$  and  $9.9$ ) and salinity ( $\text{ECe } 5\text{--}6$  and  $8\text{--}9 \text{ dSm}^{-1}$ ) are maintained in these microplots in a manner similar to field conditions minus the soil heterogeneity ( $\text{pH}_{1,2}$  denotes the pH of the mix of one part soil and two parts distilled water, hereinafter denoted as pH). These microplots are used to screen mostly early segregating populations and also stabilized populations in addition to genetic studies.

### 3 Screening in Pots

For more precise studies of individual plant response under constant stress, round porcelain or plastic pots of 20–30 cm diameter, with a capacity of 4 or 16 kg soil and a provision to allow or prevent leaching from the bottom portion, are used. Genetic and physiological studies on salt tolerance that require precision are mostly done in pots using either sand or soil culture.

### 4 Salinity Screening in Solution Culture

The solution culture technique is used in two ways: first, for screening up to seedling stage; second, for screening up to maturity. In the first category, 7-day-old seedlings grown on non-stress modified Yoshida culture solution (Table 7) are transferred to the desired level of stress, either in a breadbox-type container with perforated lids or in perforated styrofoam with nylon mesh (Fig. 5). This modified culture solution has  $\text{KH}_2\text{PO}_4$  and  $\text{K}_2\text{HPO}_4$  in place of  $\text{NaH}_2\text{PO}_4$ , as sodium salt within culture solution may increase the Na ion concentration (Yoshida et al. 1976; T.J. Flowers, personal communication, 2007).

In the IRRI phytotron, 4-day-old germinated seeds are treated with 100–120 mM salinity (usually NaCl) to select tolerant genotypes. IR-66946-3R-178-1-1 (FL478) and IR29 are usually used as tolerant and sensitive checks, respectively (Gregorio et al. 1997). However, at other places where the temperature and humidity cannot be maintained very well, initial saliniza-

Table 7. Rice culture solution as modified from the Yoshida et al. (1976) solution.

Stock	Reagent	g L <sup>-1</sup>	g 10 <sup>-1</sup>
1	$\text{NH}_4\text{NO}_3$	91.4	914
2	$\text{K}_2\text{SO}_4$	97.8	978
3			
(a)	$\text{KH}_2\text{PO}_4$	29.0	290
(b)	$\text{K}_2\text{HPO}_4$	8.0	80
4	$\text{CaCl}_2 \cdot 6\text{H}_2\text{O}$	175	1750
5	$\text{MgSO}_4 \cdot 7\text{H}_2\text{O}$	324	3240
6	Minor nutrients		
(a)	$\text{MnCl}_2 \cdot 4\text{H}_2\text{O}$	1.5	15.0
(b)	$(\text{NH}_4)_6\text{Mo}_7\text{O}_{24} \cdot 4\text{H}_2\text{O}$	0.074	0.7
(c)	$\text{H}_3\text{BO}_3$	0.93	4
(d)	$\text{ZnSO}_4 \cdot 7\text{H}_2\text{O}$	0.035	9.30
(e)	$\text{CuSO}_4 \cdot 5\text{H}_2\text{O}$	0.03	0.35
7	FeNaEDTA <sup>a</sup>	10.5	0.30
8	$\text{FeSO}_4$ (made fresh)	2.5	25.0

<sup>a</sup>Replace regularly.

Source: Adapted from Singh and Mishra (2004).

tion is done with 50 mM NaCl (equivalent to about 5 dSm<sup>-1</sup>) in culture solution for 3 days followed by an increase in stress up to 70–100 mM (approx 7–10 dSm<sup>-1</sup>). This may vary and should be standardized before experimentation depending upon the requirement and ambient conditions for screening. After 10–15 days, treated seedlings are used for morphological, physiological, or biochemical analyses. However, for the adult-plant tolerance screening, 2–3 week-old seedlings are transplanted in 1/2 kg capacity soil-filled pots and irrigated through an automated circulatory irrigation system. The plants are irrigated from the lower tank through a timer-controlled pump.

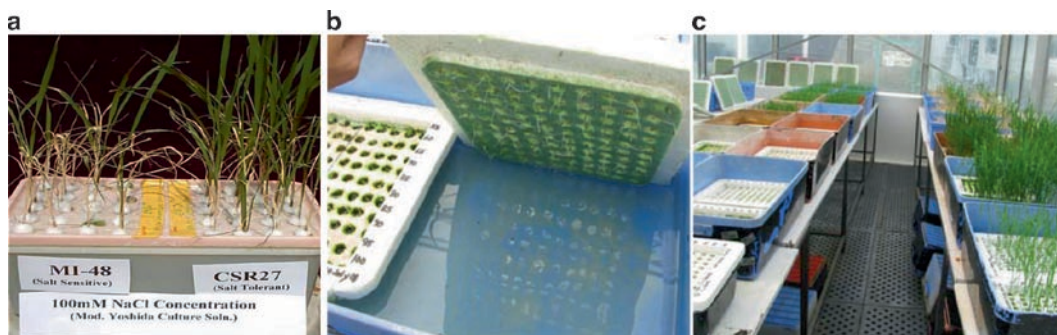

Fig. 5. Nutrient culture solution based on seedling stage screening system for salinity tolerance in rice: (a) breadbox with perforated lid (b) floats with holes and nylon mesh (c) pregerminated seeds are placed in floats [See Color Plate 10, Fig. 17].

This technique is used successfully for screening, generation advancement, and genetic and physiological studies. The schematic diagram and the actual system for solution culture screening up to adult-plant stage for salinity appear in Fig. 6 (Singh et al. 2004).

After proper establishment of seedlings, NaCl-based salinity could be raised to 50 mM in culture solution stored in a tank underneath. An automated circulatory irrigation system maintains the exact desired salinity level in the rhizosphere. Similarly, perforated pots filled with fertilized soil are also used for adult-plant screening and are kept in tanks filled with water having the desired level of salinity (Gregorio et al. 1997).

Things kept in mind when growing seedlings on non-stress modified Yoshida culture solution:

- Use 1.25 mL each stock solution per liter of culture solution
- Adjust pH 4.5 with nitric acid before adding minor nutrients
- A total of seven stock solutions
- FeNaEDTA solution: make regularly and keep in a dark bottle
- If plants are chlorotic, add 1.25 mL  $\text{FeSO}_4$  (as of no. 8) and ensure that pH is 4.5, or you can also spray leaves with 0.5% solution of  $\text{FeSO}_4$  (pH 4.4) with wetting agent or surfactant

## 5 Screening in Trays

For large-scale screening of varieties at germination/seedling stage, shallow wooden, plastic, or metal germination trays, with or without polythene sheet lining on the inner surface and filled with salt-affected soil, are used. These trays are most convenient for controlling salinity, sodicity and moisture. They allow a simulation of germination response in the field, giving not only a quantitative indication of relative germination and survival rates but also the relative delay in germination under salinity and sodicity stresses.

### B Screening Criteria

The screening criteria for salinity tolerance depend on plant growth stage. Some are limited to the germination stage only, whereas many can go up to the adult-plant stage. Germination-stage screening involves only about a week of study, a seedling-stage study takes about 3–4 weeks and an adult-plant study depends upon the maturity duration of the plant. Therefore, the techniques to be employed for screening and evaluation would depend upon the type and stage of the materials in addition to the research objectives.

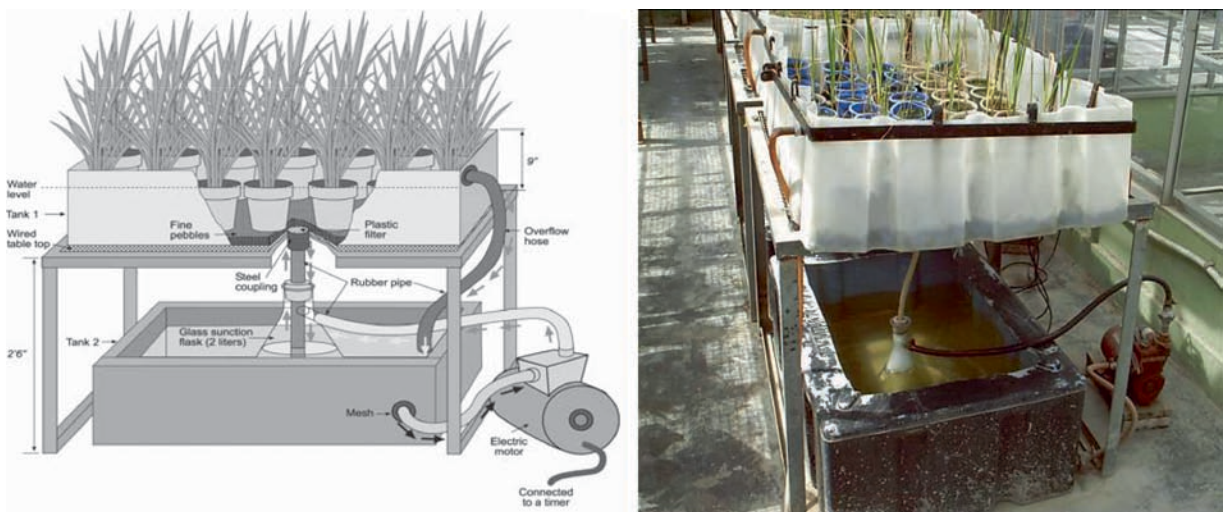

Fig. 6. Line diagram and actual system for adult-plant screening (Adapted from Singh and Mishra 2004).

### 1 Morphological Parameters

Though no single definitive morphological marker is available for salt tolerance or sensitivity in any crop, a combination of criteria can provide a good indication of how different crop species respond to salt stress. Therefore, several parameters are used in combination to ensure effective and reproducible screening. The most important screening parameters are seedling vigor and survival, phenotypic acceptability score using the standard evaluation system (SES) of IRRI (1996), mean tolerance index and grain yield, among others.

### 2 Germination Parameters

Germination percentage and coleoptile and radicle lengths under varying degrees of salt stress for different crops are good indicators of salt tolerance at the initial stages of plant growth. Extensive studies have been conducted in rice that found higher soil exchangeable sodium percentage (ESP) and salinity to delay or reduce germination.

### 3 Plant Survival

This is mainly limited to seedling-stage studies but has also been used to some degree in some adult-plant studies. Under moderate stress, plant survival is not a problem, but under higher stress it is a good selection criterion.

### 4 Injury Score

Individual plants or a group of genotypes are usually scored on a 1–5 or 1–9 scale where lower values denote tolerance and higher scores indicate sensitivity of the genotypes. In rice, IRRI's (1996) SES score for salt injury is the most preferred screening and phenotyping system, as follows:

- Score 1 (highly tolerant) – Normal plant growth, only the old leaves show white tips with no symptoms on young leaves
- Score 3 (tolerant) – Near normal growth, but only leaf tips burn, a few older leaves become partially whitish
- Score 5 (moderately tolerant) – Growth severely retarded, most old leaves severely injured, a few young leaves elongating

- Score 7 (sensitive) – Complete cessation of growth, most leaves dried, only a few young leaves still green
- Score 9 (highly sensitive) – Almost all plants dead or dying

### 5 Phenotypic Expression

Excessive tip burning, especially in younger leaves, spikelet sterility, and stunted growth are considered for the overall phenotypic expression of a genotype under a stress environment.

### 6 Growth Parameters

Salt stress severely affects dry and fresh weights of roots and shoots. However, genotypic differences have been observed in the degree of reduction occurring for these parameters.

### 7 Grain Yield

In the absence of any simple and reliable selection criteria, a 50% reduction in grain yield of genotypes under salt stress relative to normal (non-stress) conditions has been considered as the critical limit for selection/rejection of genotypes. This is a major criterion for screening and evaluation of advanced breeding materials (Mishra and Bhattacharya 1980; Mishra 1996).

### 8 Stability of Traits over Environments

Genotypes with a high mean, near to unit regression value ( $b_i$ ), and uniformity of regression ( $S_{di}^2$ ) under multiple-stress environments are judged as the most suitable, stable and adaptable for sustainable productivity in problem soils. A high mean yield is a fundamental selection criterion for all varieties, whereas selection based on unit regression value and least deviation from regression indicates stability of performance across a range of environments (Singh and Mishra 1997).

### 9 Mean Tolerance Index (MTI)

This is the product of the stress resistance index (SRI) and the response index (RI) of a genotype, where SRI is the performance of a genotype for a trait averaged over all stress environments and relative to the performance under corresponding



non-stress environments, and RI is the mean of the genotype for the trait under all stress environments divided by the mean performance of all genotypes over all stress locations (Rana 1986).

### 10 Associated Traits

Association studies reveal that the number of productive tillers, grains per panicle, and panicle length, among other traits, are positively correlated with grain yield in rice. Selection for traits with strong positive correlations with yield under salt stress automatically identifies high-yielding genotypes under stress conditions.

### 11 Physiological and Biochemical Parameters

Extremely high salt concentration kills the plant but moderate salt stress results in growth differences among crop varieties because of changes in major metabolic activities. Breeding crop varieties for problem soils such as those with salinity very often creates conditions in which visible/morphological traits do not provide sufficient information for effective selection of desired segregants and potential donor materials. Salt tolerance is a complex phenomenon because it involves combinations of different independent and/or interdependent mechanisms and pathways. A tolerant genotype can be expected to have more than one adaptation. A vast number of indigenous and exotic germplasm materials have been screened for the selection of potential donors for different physiological mechanisms responsible for salt tolerance. Many physiological parameters could be taken as robust and reliable screening criteria, but the most important ones are cation ( $\text{Na}^+$  and  $\text{K}^+$ ) uptake,  $\text{Na}^+/\text{K}^+$  ratio, and tissue tolerance. Tissue tolerance is measured in terms of  $\text{LC}_{50}$ , which is the concentration of sodium (in  $\text{mmol g}^{-1}$  ethanol-insoluble dry wt.) in the leaf tissue that causes a 50% loss of chlorophyll (Yeo and Flowers 1983). Similarly, an accumulation or increase in the amount of certain amino acids, sugars, and other osmotically active organic substances in plants in response to salt stress is an indication of altered nitrogen and carbohydrate metabolism. We are not going into the details of the physiological and biochemical mechanisms as that is beyond the scope of this chapter and these are also discussed elsewhere in the book.

### C Selection Pressure

The effect of salt stress on the plant depends on the growth stage, degree of stress, and environmental conditions. Rice is particularly sensitive to salt stress during the seedling and flowering stages. Extremely high salt stress or above-optimal salt conditions cause severe damage to plants or even plant death at these stages, whereas moderate salt stress affects the rate of plant growth and reduces most growth and yield parameters, such as tillering, stunting, spikelet sterility, florets per panicle, and 1,000-grain weight, and leads to leaf scorching, etc. Minimal salt stress sometimes does not visibly differentiate tolerant and sensitive plants, but this is important for studies on protein and enzyme alterations. Moderate ( $4\text{--}8 \text{ dSm}^{-1}$ ) and high ( $8\text{--}12 \text{ dSm}^{-1}$ ) salt stresses are most important depending upon the requirement and objective of the experiment. For example, an electrical conductivity of the soil or solution culture of about  $6\text{--}8 \text{ dSm}^{-1}$  is considered moderately saline while  $8\text{--}12 \text{ dSm}^{-1}$  as high stress for rice at seedling-stage screening. It is good to screen at higher ( $>8 \text{ dSm}^{-1}$ ) salinity for adult plant screening but if the screening is for throughout plant growth, it should be kept at the moderate level. But, all these levels vary with external environmental conditions like temperature and RH.

### X Breeding Strategy to Enhance Salinity Tolerance Through Pyramiding of Mechanisms

Salinity tolerance is the overall manifestation of the sum of component traits that are controlled by many physiochemical and biochemical pathways. If tolerance is to be enhanced, the contributing mechanisms need to be pooled together into one genetic background without incurring a significant penalty. To achieve this, the first step would be to group genotypes based on the presence of the predominant physiological mechanisms responsible for salinity tolerance such as tissue tolerance,  $\text{Na}^+$  exclusion,  $\text{K}^+$  uptake, and  $\text{Cl}^-$  exclusion. The second step would be to intercross the parents from different groups rather than from within a group. This will result in genotypes with a high degree of expression of the contrasting salinity tolerance mechanism being recombined for enhanced

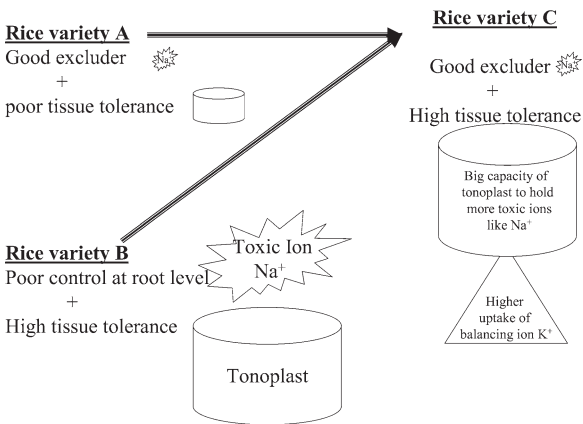

Fig. 7. Recombining different salt tolerance mechanisms to enhance salt tolerance.

salt tolerance in their offspring. The segregants should be screened for the desired recombinants with two or more tolerance mechanisms (Fig. 7). For example, if we have two varieties, one that uptakes toxic ion ( $\text{Na}^+$ ) in less amount such as CSR10 but has less capacity to hold more  $\text{Na}^+$  within the plant and another variety that has more capacity to hold the  $\text{Na}^+$  but has a daily toxic ion uptake that is too much like that of Swarna such that it dies very quickly when its tonoplast is filled to capacity quickly, then, ideally, the most desired variety should have a limited daily  $\text{Na}^+$  uptake and also a high capacity to hold more sodium in the tonoplast along with a balancing effect of  $\text{K}^+$  ions. This condition is certain to raise the limit of salt tolerance in the plant. IRRI has already developed such pyramided lines with a desired combination of extreme phenotypes. The ideal recombinant should be able to withstand high concentrations of tissue  $\text{Na}^+$  (tissue tolerant), have a minimum level of per-day uptake of  $\text{Na}^+$  (it takes more days to reach  $\text{LC}_{50}$  stage), possess a high uptake of  $\text{K}^+$  per day, have good initial vigor, and be agronomically superior with high yield potential.

## XI Testing Approaches for Varietal Adaptability

### A Station Trials

When the selected breeding materials become almost homozygous, they are tested in replicated trials on a large-plot basis and, where possible, at

many locations. Multilocation testing allows the true overall genetic worth of the genotypes to be assessed, an important final step before nomination of elite entries to coordinated national trials that become the basis for releasing varieties for different agro-climatic zones.

### B Target Area-Based/Network Approach

The variability and complexity of adverse soils, which are often compounded by climatic hazards, are associated with nutritional toxicities or deficiencies, and are influenced by the interactions of soil and environmental factors. Thus, target sites or hot spots are first identified and subsequently used for screening. As target sites are specific in terms of the required genetic material, especially in rice, well-adapted genetic material for those specific environments needs to be selected, tested, and bred, preferably for that target environment only. This network approach is followed in evaluating advanced breeding lines and populations from national or international networks such as the International Network for Genetic Evaluation of Rice or INGER. The major theme of the network approach is the sharing of resources for screening (in terms of their *in situ* stress conditions) to identify the best adapted materials for target areas. These are then advanced and used in breeding programs of network members to develop target-specific as well as widely adapted genotypes.

### C Farmer's Participatory Approach

Thousands of rice varieties have been developed but only a handful remain in large-scale cultivation due to non- or low-acceptance by farmers. Therefore, farmers need to become a part of the varietal development process in order to consider their preferences, which are crucial for the large-scale adoption of new varieties. Based on this concept, participatory varietal selection (PVS) has become a very popular mode of pre-testing elite materials prior to their release to ensure their eventual large-scale adoption. Plant breeders often consider yield, the ability to withstand salinity, flowering duration, and height as important traits to incorporate into varieties for salt-affected areas. However, farmers may have other important considerations and often there is a mismatch between the varieties that farmers need and the varieties that scientists offer. For example, two

PVS trials and voting of farmers on the best varieties were conducted in the wet and dry seasons of 2006 by CRRI, Cuttack, India, in coastal saline areas where electrical conductivity ranged from 8 to 13 dSm<sup>-1</sup> and in the WS of 2005 by CSSRI-RRS, Lucknow, India, in sodic soils having pH of approximately 10.3. The PVS trial in the deltaic region of Orissa in Ersama Block of Jagatsinghpur District, India, included six promising rice varieties in the WS that were evaluated by 27 farmers, and another set of five promising varieties in the DS evaluated by 22 farmers. Farmer's choices in some cases were the same as researchers' choices but the rankings differed (Table 8). For example, in the WS, Lunishree, though having good yield and salinity tolerance, was not preferred by a majority of the farmers because of its lodging tendency and difficulty in threshing. Nearly 80% of the farmers selected SR 26B and Patnai 23 but only a few selected the three CRRI lines despite their good plant type and high yield potential. In the DS, almost all the farmers preferred IR72046-B-R-3-3-1, while 80% or more of the farmers selected

Annapurna and IR72593-B-19-2-3-1. Annapurna has red kernel but has good eating quality. Canning 7 also has good yield potential but was not rated high because of its grain-shattering habit. Farmers' preferences based on their own selection indices were quite close to the researchers' preferences in coastal saline soils but the similarity was very poor under sodic soils. However, rank correlations ( $r_s$ ) for all preferences under coastal saline and sodic soils were statistically non-significant (Table 8). This shows poor association between what researchers think and what farmers perceive. Farmers' perceptions, as assessed through PVS, therefore, are a valuable input for breeding suitable materials, which is particularly important for the fragile salt-affected ecologies because of the heterogeneity of choices of farmers, who usually live in remote areas. These results on the mismatch of the rankings given to genotypes by farmers and researchers support the important role that PVS can play in ensuring better adaptability of new varieties (Singh et al. 2008b).

Table 8. Farmer's versus researcher's ranking of preferences for different salt-tolerant varieties.

Varieties used in PVS	Varietal ranking		Rank correlation $r_s$	Table value at $n - 2$ df	
	Farmers	Researchers		5%	1%
Location: Ersama Block, Jagatsinghpur Distict, Orissa, India					
2006 wet season					
SR26B	1	1	0.771 <sup>a</sup>	0.811	0.917
Patnai 23	2	3			
Lunishree	3	2			
CR2096-71-2	4	5			
CR2069-16-1	5	6			
CR2093-7-1	6	4			
2006 dry season					
IR72046-B-R-3-3-3-1	1	1	0.70 <sup>a</sup>	0.878	0.959
Annapurna	2	3			
IR72593-B-19-2-3-1	3	4			
CSR4	4	2			
Canning 7	5	5			
Location: Mataria Village, Unnao District, Uttar Pradesh, India					
2005 Kharif – WS		25% Gypsum requirement plots			
2K219	1	2	0.018 <sup>a</sup>	0.754	0.874
CSR30	2	6			
2K262	3	3			
IRRI-2K8	4	5			
CSR23	5	4			
CSR27	6	7			
CSR36	7	1			

<sup>a</sup>ns is non-significant.

Source: Adapted from Singh et al. (2008b).

## XII Factors Affecting Salt Tolerance

### A Agronomic Factors

Many agronomic factors besides genetic potential affect the salt tolerance of plants. These include water regime, water quality, fertility level, land leveling, sowing/transplanting methods, crop rotation and ontogenic drift. Here, we describe only ontogenic drift as other factors are beyond the scope of the chapter.

**Ontogenic Drift:** This is the change in genotypic expression with plant development. Rice is considered as a salt-sensitive crop, with a salinity threshold of as low as 3 dSm<sup>-1</sup> (Maas and Hoffman 1977). But this sensitivity varies with plant growth stage. As depicted in Fig. 8, rice is relatively tolerant during germination, becomes very sensitive during the early seedling stage, gains tolerance during the active tillering stage, but becomes sensitive during panicle initiation, anthesis, and fertilization, and then becomes relatively more tolerant at maturity (Makihara et al. 1999; Singh et al. 2004; Rao et al. 2008). Thus, the seedling and reproductive stages are the most vulnerable to salt stress and plants experience greater damage from salt stress mostly in these specific stages. Studies have shown that a very poor correlation exists between tolerance at the seedling stage and that during reproduction (Table 9), suggesting that tolerance at these two stages is regulated by a different set of genes (Mishra 1994; Moradi et al. 2003). The vegetative stage is less affected by both saline

Table 9. Association of salinity tolerance score at different growth stages with grain yield in rice.

Association between	Correlation coefficient	
	Glasshouse studies	Field studies
Vegetative-stage tolerance vs. grain yield	-0.58 <sup>a</sup>	-0.022 <sup>a</sup>
Reproductive-stage tolerance vs. grain yield	-0.97*	-0.82*
Vegetative-stage vs. reproductive-stage tolerance	0.59 <sup>a</sup>	0.34 <sup>a</sup>

<sup>a</sup> non-significant

\*Highly significant at p = 0.01.

Source: Adapted from Mishra (1996).

and sodic stress than the reproductive stage (Rao et al. 2008). The reproductive stage is crucial as it ultimately determines grain yield; however, the importance of the seedling stage is no less as it affects crop establishment.

### B Climatic Factors

Temperature and relative humidity (RH) are the most important climatic factors affecting salt tolerance. Temperature regime greatly influences the growth duration and growth pattern of almost all crop plants under normal soil conditions. Crop plants have critical temperatures for different stages. Temperatures higher than the critical temperature greatly affect plant growth, especially under salt stress. Under high-temperature conditions, for example, plant transpiration increases to maintain the plant's

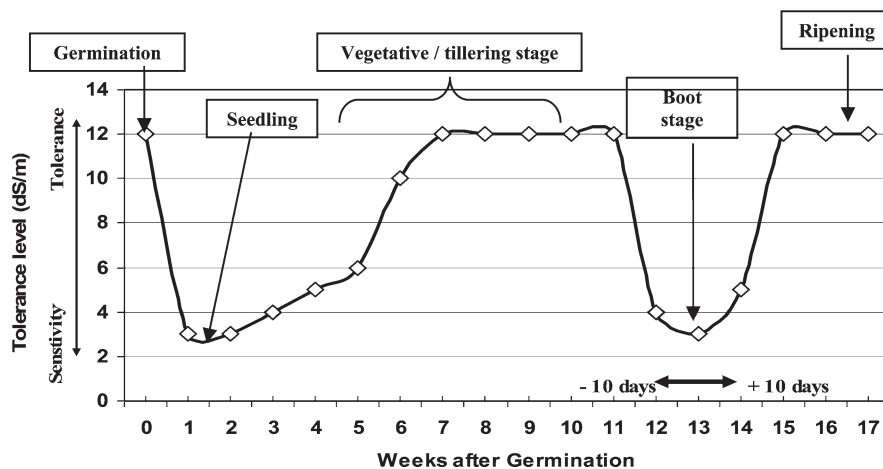

Fig. 8. Rice growth stages vis-à-vis salt tolerance (Adapted from Singh et al. 2008a).



internal temperature and, in the process, more salt enters into plant tissues at a rapid pace. Over accumulation of salts ultimately leads to severe injury or death of the plant. Therefore, a tolerant plant under a normal temperature regime may behave as sensitive under a hot and dry environment. RH, on the other hand, also plays an important role under salt stress. Dry weather and very low humidity increase the evapo-transpiration rate of plants while the reverse is true with high humidity. Similar to the conditions under high temperature, very low humidity in a stress environment is detrimental to plant growth because of higher ion uptake (Singh et al. 2005).

### C Soil Texture and Structure

Soil texture and structure greatly affect the expression of plant traits. A genotype can behave differently with its inherent salt tolerance in different soil textural classes at a particular stress level. Heavy clay soils impose more stress on a plant than sandy soils even if the ESP of both soil types is the same. In other words, a genotype that can tolerate 35 ESP in silty-loam soil will show sensitivity or poor tolerance in clay soils, while it would perform better under sandy soils at the same ESP. Moreover, the stress in clay soils will be more detrimental and long lasting than in light-textured soils because of the higher cation exchange capacity (CEC) and smaller pore size of clay soils.

### D Rainfall

A good rainfall lowers salt stress in the soil to a certain extent. Soluble salts are washed out in saline soils and sodic soils and stress also become less severe due to the dilution effect from good-quality rainwater. A crop such as rice that favors water stagnation is benefited most by a well-distributed rainfall pattern. However, more rains for crops such as wheat even under reclaimed sodic soils greatly affect the crop as the infiltration rate is lower in such soils and water stagnation for even just a few days damages the wheat crop severely. Some recent experiments at CSSRI, Karnal, on the development of wheat varieties for better tolerance of waterlogging have identified promising materials that can withstand 5–10 days of water stagnation without much effect on yield.

## XIII Collaborative Research

Collaborative research on abiotic stresses has been traditionally done through the International Network for Genetic Evaluation of Rice (INGER), a 33-year-old partnership among varietal improvement programs of rice-growing countries around the world and International Agricultural Research Centers (IARCs) such as IRRI, the Africa Rice Center (WARDA) and the Centro Internacional de Agricultura Tropical (CIAT). Established in 1975 as the International Rice Testing Program, or IRTP, INGER is a proven global platform for the multilateral exchange, evaluation, and use of elite rice breeding and genetic resources and related information. From the very beginning, INGER has been useful for testing breeding lines from various programs in as many as 85 countries. Evaluation is done through predefined experimental sets or nurseries that are distributed yearly to cooperating scientists for evaluation. Several nurseries deal with abiotic stresses (Table 10) and covers salinity tolerance screening at the International Rice Soil Stress Tolerance Observational Nursery (IRSSTON). The best nursery entries are selected either for direct use and release as varieties or for use as parental donors in their own breeding programs. Up to 2007, 667 INGER

Table 10. INGER nurseries for abiotic stresses/unfavorable ecosystems composed in 2006-2007.

Sl no	Nursery	2006	2007
1	International Boro Rice Observational Nursery (IRBON)	x	x
2	International Temperate Rice Observational Nursery (IRTON)	x	x
3	International Rainfed Lowland Rice Observational Nursery (IRLON)	x	x
4	International Upland Rice Observational Nursery (IURON)	x	x
5	Aerobic Rice Observational Nursery (AERON)	x	x
6	International Rice Cold Tolerance Nursery (IRCTN)	–	x
7	International Rice Soil Stress Tolerance Observational Nursery (IRSSTON)	x	x
8	International Rice Drought Tolerance Nursery (IRDTN)	–	x
9	International Rice Heat Tolerance Nursery (HeatTol)		x

Source: Adapted from Toledo et al. (2007).

entries were released directly in 62 countries using the INGER mechanism (Toledo et al. 2007). Those found promising at specific locations were used in making thousands of crosses, hundreds of derivatives of which were also released as varieties in various countries. The 47 rice varieties released in Bangladesh since 1970, for example, have 33 INGER entries from six countries in

their pedigrees, whereas 14 INGER introductions from eight countries have been used as parents of varieties released in Malaysia (Redoña et al. 2008). The promising entries selected for the salinity tolerance nursery from 2003 to 2005, for example, are presented in Table 11.

Table 11. Outstanding entries in the IRSSTON nursery, 2004–2005.

Year	Location	Entry	Origin	
2004	Sakha, Egypt	IR51500-AC11-1	IRRI	
		IR59418-7B-27-3	IRRI	
		IR59418-7B-28-2	IRRI	
		IR61246-3B-20-2-2-2	IRRI	
		IR61919-3B-14-3	IRRI	
		IR63295-AC212-2	IRRI	
		IR63307-4B-24-2	IRRI	
		Sakha 104	Egypt	
		Karnal, India	IR51500-AC11-1	IRRI
			IR52713-2B-8-2B-1-2	IRRI
	IR58427-5B-15		IRRI	
	IR58443-6B-10-3		IRRI	
	IR61919-3B-14-3		IRRI	
	IR64197-3B-14-2		IRRI	
	IR64197-3B-8-2		IRRI	
	IR64419-3B-1-1		IRRI	
	IR64419-3B-12-2		IRRI	
	IR64419-3B-3-2		IRRI	
	IR64419-3B-4-3	IRRI		
	IR64426-4B-11-1	IRRI		
IR64426-4B-13-1	IRRI			
IR64426-4B-17-2	IRRI			
PR26016-B-B-B	Philippines			
2005	Cuttack, India	IR65180-4B-14-2	IRRI	
		IR68654-3B-9-1	IRRI	
		IR70870-B-P-3-2	IRRI	
		IR63731-1-1-4-3-2-2	IRRI	
	Canning, India	IR65180-4B-11-2	IRRI	
		IR65192-4B-4-2	IRRI	
	Kumarganj, India	Nona Bokra	India	
		IR61925-3B-1-1	IRRI	
		IR65192-3B-1-1-3	IRRI	
		IR65192-4B-3-2	IRRI	
IR65192-4B-4-2		IRRI		
IR95199-4B-10-1-2		IRRI		
IR65796-24-2-2	IRRI			
IR65796-3B-12-1-3	IRRI			

Source: Adapted from INGER Reports.

#### XIV Rice Varieties Developed for Salt Tolerance

The first systematic attempt to breed salt-tolerant varieties in the early 1980s initiated by CSSRI, Karnal, India, resulted in the development of the first high-yielding, salt-tolerant, and early-maturing rice variety, CSR10. It was released in 1989 by the Central Varietal Release Committee (CVRC) for sodic and inland saline soils of India. This variety can withstand highly deteriorated sodic ( $\text{pH}_2$  9.8–10.2) and inland saline soil ( $\text{ECe}$  6–10  $\text{dSm}^{-1}$ ) conditions under a transplanted irrigated management system (Mishra et al. 1992). However, because of its short stature, it is not suited for coastal saline soils where water stagnation is a problem. Its yield potential is 5–6  $\text{t ha}^{-1}$  under normal soil and 3–4  $\text{t ha}^{-1}$  under highly deteriorated salt-affected soils. Under moderate stress, it can yield from 4 to 5  $\text{t ha}^{-1}$  (Dagar et al 2001; Flowers et al. 2000). After its successful release and adoption, many new varieties with better agronomic characteristics were released in different countries (Table 12).

Table 12. Rice varieties released for commercial cultivation in salt-affected soils.

Country	Variety name/designation
Philippines	IRRI 112 as PSBRc48 (Hagonoy), IRRI 113 as PSBRc50 (Bicol), IRRI 124 as PSBRc84 (Sipocot), IRRI 125 as PSBRc86 (Matnog), IRRI 126 as PSBRc88 (Naga), IRRI 128 as NSICRc106, IRRI 147 as NSICRc 182 (Salinas1)
India	CSR10, CSR13, CSR23, CSR27, CSR30 (Yamini), CSR36 (Naina); Lunishree; Vytilla 1, Vytilla 2, Vytilla 3, Vytilla 4, Vytilla 5, Vytilla 6; Panvel 1, Panvel 2, Panvel 3; Sumati, Jarava; Bhutnath; Usar dhan 1, Usar dhan 2, Usar dhan 3
Bangladesh	BRRi dhan 40, BRRi dhan 41, BRRi dhan 47
Vietnam	OM576, OM2717, OM2517, OM3242, AS996
Egypt	Giza 177, Giza 178, Sakha 104, Sakha 111

## **XV Impact of Salt-Tolerant Rice Varieties**

### *A Direct Impact*

The development of improved salt-tolerant materials directly benefits farmers in salt-affected lands by increasing their harvest. Tolerant varieties increase food production even from fields with poor to zero productivity, thereby improving the economy and well-being of the poor farmers/landowners in addition to generating employment opportunities for the local population during the crop season. This ultimately results in improved status of the state's and country's granaries. However, it is difficult to estimate and quantify the direct impact of salt-tolerant varieties per se. Their adoption, popularity, and impact could be measured indirectly from farmer seed demand data in the breeder/foundation/certified seed production chain. CSSRI, Karnal, has shown the impact of its salt-tolerant varieties on food production under a World Bank – supported land reclamation project in India. More than 200,000 ha have been reclaimed and brought back into production through a land development corporation in Uttar Pradesh, India which used salt-tolerant rice varieties as one of the key components of the reclamation package (UPLDC 1995; UPBSN 1999).

### *B Indirect Impact*

Several laboratories and research institutions are using the knowledge emanating from both basic and applied research techniques on salinity. The screening techniques in artificially created environments have become standardized and the proven methodology to breed high-yielding salt-tolerant varieties in different crop plants has been adopted by most stress breeding and physiology laboratories. Many laboratories are now using the database generated on the genetic donors for the various stresses that previously was not available anywhere for reference data. In this manner, new users and researchers do not need to start afresh for the identification and use of donors.

Another notable impact of breeding for salt tolerance is the return of unproductive and barren lands or lands with very low productivity into the rice production chain. Consider two scenarios: first, a new high-yielding variety replaces another

old variety and increases yield from 5 to 6 t ha<sup>-1</sup> with a yield advantage of 1 t ha<sup>-1</sup> only; second, unproductive barren land is cultivated using a salt-tolerant rice variety with no or a small amount of chemical amendment, which yields about 3 t ha<sup>-1</sup> in the first year and more in subsequent years. Comparing the two scenarios, the productivity is more in the first scenario but the yield advantage is about thrice that in the second scenario in addition to more land being put into cultivation. Therefore, the long-term impact of salt-tolerant rice varieties is tremendous for productivity, environment, employment generation, and food security. It is advantageous for both the vertical and horizontal expansion of food production from unfavorable rice-growing environments.

## **XVI Conclusions**

Although progress has been attained in developing rice varieties tolerant of abiotic stresses in general, and of salinity in particular, much has yet to be done to fully exploit the productivity increases to be gained through breeding. For this, the future looks promising. First, research has shown that genetic variation exists in rice germplasm for the key abiotic stresses that could be exploited through breeding. Second, screening and phenotyping techniques have been developed that allow for a more precise estimation of the true genetic worth of both donors and breeding products in terms of tolerance of abiotic stresses. Third, modern tools such as molecular markers and techniques such as marker-aided selection as well as more innovative but conventional diallel selective mating system that allows for a more systematic creation or assembly of the desired genetic variability on which to practice directional selection to obtain desirable genotypes in a precise and rapid manner. Fourth, new varietal release systems are being adopted in countries such as India that facilitate the testing and release of MAS-developed products, particularly those involving simple value addition in which single genes or a few genes are integrated into widely adapted genetic backgrounds. These improved systems should allow the fast-tracking of the release of promising breeding lines derived from backcross breeding programs currently under way at IRRI and in various national programs. Finally, newly developed technology promotion

strategies such as participatory varietal selection and those that welcome the involvement of farmers in the design and implementation of breeding programs should increase the likelihood of adoption for the new stress-tolerant varieties in the future. Pyramiding abiotic stress tolerance with biotic stress tolerance, yield, and grain quality should bring breeders closer to the coveted goal of producing the ultimate rice ideotypes. Sharing these new and much improved varieties among breeders and countries will also be facilitated by the new rules implemented under the International Treaty on Plant Genetic Resources for Food and Agriculture that counts 118 countries (FAO 2008) as parties, thereby maximizing their impact in rice-producing countries, particularly among resource-poor farmers.

## XVII Recommendations and Future Lines of Research

- Development and standardization of high-throughput screening for many other abiotic stress conditions such as reproductive-stage salinity tolerance, Zn-deficiency tolerance, Fe-toxicity and -deficiency tolerance, P-deficiency tolerance, high- and low-temperature tolerance, and acidity and sodicity tolerance. As in salinity tolerance at the rice seedling stage, the screening techniques to be developed should be simple, inexpensive, reproducible, and capable of high throughput.
- Identification of suitable donors for tolerance of different abiotic stresses and grouping these donors based on their predominant inherent tolerance mechanisms. This would facilitate the pyramiding of tolerance genes underlying different tolerance mechanisms into a common genetic background.
- Since most abiotic stresses are stage specific, robust molecular markers that allow for the early selection of tolerant genotypes could be of immense help as they are stage and environment independent and also co-dominant (microsatellite markers), thus differentiating the homozygotes and heterozygotes. Identification of such markers will increase the efficiency and pace of varietal development.
- Since tolerance is highly affected by environmental factors, variation in external factors must be considered when developing

abiotic stress-tolerant genotypes. Efforts to reduce this variation using appropriate experimental designs and similar management techniques should be made to increase the precision of the selection process.

- All the information about the screening protocols, donors, markers, and availability of improved material and the process to acquire germplasm should be consolidated for open access and sharing through a web site for potential users from across the globe. This will reduce redundancy in abiotic stress research, promote collaboration, and hence save resources, particularly in developing countries.
- Mechanisms and platforms for the open and rational access to improved germplasm generated by both the public and private sector should be developed, supported, and sustained by the scientific community for the faster development and deployment of new varieties and their widespread on-farm use to increase farm productivity, particularly for resource-poor farmers.

## References

- Akbar M, Yabuno T (1972) Breeding for saline resistant varieties of rice. I. Variability for salt tolerance among some rice varieties. *Jpn J Breed* 22:277–284
- Akbar M, Yabuno T (1975) Breeding for saline resistant varieties of rice. III. Response of  $F_1$  hybrids to salinity in reciprocal crosses between Jhona 349 and Magnolia. *Jpn J Breed* 25:215–220
- Akbar M, Yabuno T (1977) Breeding for saline resistant varieties of rice. IV. Inheritance of delayed type panicle sterility induced by salinity. *Jpn J Breed* 27:237–240
- Akbar M, Khush GS, Hillerislambers D (1985) Genetics of salt tolerance. In: Rice genetics. IRRI, Los Bafios, Philippines, pp 399–409
- Allard RW (1999) Principles of plant breeding, 2nd edn. Wiley, New York, p 178
- Bonacci O (1993) Hydrological identification of drought. *Hydrol Processes* 7:249–262
- Camargo CEO (1984) Tolerance of rice cultivars in seedling stage to different levels of iron in nutrient solution. *Bragantia* 43:369–380
- Dagar JC, Sharma HB, Shukla YK (2001) Raised and sunken bed techniques for agroforestry on alkali soils of northwest India. *Land Degrad Dev* 12:107–118
- Evenson RE, Gollin D (1997) Genetic resources, international organizations and improvement in rice varieties. *Econ Dev Cult Change* 45:471–500



- Fageria NK (1985) Salt tolerance of rice cultivars. *Plant Soil* 88:237–243
- Fageria NK, Barbosa FMP (1982) Screening rice cultivars for low level of phosphorus tolerance. *Rev Bras Cinec Solo* 6(2):146–151
- Flowers TJ, Koyama ML, Flowers SA, Sudhakar C, Singh KP, Yeo AR (2000) QTL: their place in engineering tolerance of rice to salinity. *J Exp Bot* 51:99–106
- Food and Agriculture Organization (FAO) (2006) FAOstat – agriculture database. <http://faostat.fao.org/site/567/default.aspx> (July 30, 2008)
- Food and Agriculture Organization (FAO) (2008). The International Treaty on Plant Genetic Resources for Food and Agriculture (ITPGRFA). [www.planttreaty.org/](http://www.planttreaty.org/) (July 30, 2008)
- Food and Agriculture Organization. Database <http://apps.fao.org/page/collections?subset=agriculture> (July 31, 2008)
- Gao JP, Chao DY, Lin HX (2007) Understanding abiotic stress tolerance mechanisms: recent studies on stress response in rice. *J Integr Plant Biol* 49(6):742–750
- Gregorio GB, Senadhira D (1993) Genetic analysis of salinity tolerance in rice (*Oryza sativa* L.). *Theor Appl Genet* 86:333–338
- Gregorio GB, Senadhira D, Mendoza RD (1997) Screening rice for salinity tolerance. IRRI Discussion Paper Series No 22. IRRI, Metro Manila, Philippines, p 30
- Gregorio GB, Senadhira D, Mendoza RD, Manigbas NL, Roxas JP, Guerta CQ (2002) Progress in breeding in salinity tolerance and associated abiotic stresses in rice. *Field Crops Res* 76:91–101
- Gupta D (1999) Genetics of salt tolerance and ionic uptake in rice (*Oryza sativa* L.). Ph.D thesis. BRA University, Agra, India, p 112
- Hossain M, Gollin D, Cabanilla V, Cabrera E, Jonson N, Khush GS, McLaren G (2002) International research and genetic improvement in rice – evidence from Asia and Latin America. In: Evenson RE, Gollin D (eds) *Crop variety improvement and its effect on productivity: the impact of international agricultural research*. CABI, United Kingdom, pp 71–107
- Ikehasi H, Ponnampereuma FN (1978) Varietal tolerance of rice to adverse soils. In: *Soils and Rice*. IRRI, Philippines, pp 801–803
- Ismail AM, Heuer S, Thomson MJ, Wissuwa M (2007) Genetic and genomic approaches to develop rice germplasm for problem soils. *Plant Mol Biol* 65:547–570
- IPCC (Intergovernmental Panel on Climate Change) (2007) *Climate Change 2007: the physical science basis (summary for policymakers)*. IPCC Secretariat, WMO, Geneva, Switzerland, p 21
- IRRI (1996) Standard evaluation system for rice, 4th edn. IRRI, Philippines
- Jensen NF (1970) A diallel selective mating system for cereal breeding. *Crop Sci* 10:629–635
- Johannsen W (1903) Om arvelighed i samfund og i rene linier. Oversigt over det. Royal Danish Academy of Sciences and Letters. *Forhandling* 3:247–270
- Lane A, Jarvis A (2007) Changes in climate will modify the geography of crop suitability: agricultural biodiversity can help with adaptation. *SAT eJournal* 4(1):1–12
- Lilley JM, Ludlow MM (1996) Expression of osmotic adjustment and dehydration tolerance in diverse rice lines. *Field Crops Res* 48:185–197
- Maas EV, Hoffman GJ (1977) Crop salt tolerance: Current assessment. *ASCEJ Irrig Drain Div* 103:115–134
- Maclean JL, Dawe DC, Hardy B, Hettel GP (eds) (2002) *Rice almanac*. Los Baños (Philippines): International Rice Research Institute, Bouaké (Côte d'Ivoire): West Africa Rice Development Association, Cali (Colombia): International Center for Tropical Agriculture, Rome (Italy): Food and Agriculture Organization, p 253
- Mahadevappa MM, Ikehashi HP, Ponnampereuma FN (1979) The contribution of varietal tolerance for problem soils to yield stability in rice. IRRI Paper Series No 43:1–15
- Makihara D, Makoto T, Miho M, Yoshihiko H, Toshiro K (1999) Effect of salinity on the growth and development of rice (*Oryza sativa* L.) varieties. *Jpn J Trop Agric* 43:285–294
- Massoud FI (1974) Salinity and alkalinity. In: *A world assessment of soil degradation: An International Programme of Soil Conservation (Report of an Expert Consultation on Soil Conservation)*. FAO UNEP, Rome, pp 16–17
- Melloulou A, Collin M (2006) Hydrogeological changes in coastal aquifers due to sea level rise. *Ocean Coastal Manage* 49:281–297
- Mishra B (1991) Combining ability and heterosis for yield and yield components related to reproductive stage salinity and sodicity tolerance in rice, *Oryza sativa* L. International Rice Research Institute, Rice Genetics II, Manila, Philippines, p 761
- Mishra B (1994) Breeding for salt tolerance in crops. In: Rao et al. (eds) *Salinity management for sustainable agriculture: 25 years of research at CSSRI*. Central Soil Salinity Research Institute, Karnal, India, pp 226–259
- Mishra B (1996) Highlights of research on crops and varieties for salt affected soils. Technical Bulletin Published by CSSRI, Karnal, p 28
- Mishra B, Bhattacharya RK (1980) Limits of varietal tolerances to sodicity in rice. In: *Proceedings of International Symposium on Salt-Affected Soils*. CSSRI, Karnal, India, pp 502–507
- Mishra B, Akbar M, Seshu DV (1990) Genetic studies on salinity tolerance in rice towards better productivity in salt-affected soils. *Rice Research Seminar: July 12, 1990*, IRRI, Philippines
- Mishra B, Singh RK, Bhattacharya RK (1992) CSR10, a newly released dwarf rice for salt affected soils. *Int Rice Res Newsl* 17:19
- Mishra B, Akbar M, Seshu DV, Senadhira D (1996) Genetics of salinity tolerance and ionic uptake in rice. *Int Rice Res Newsl* 21:38–39

- Mishra B, Singh RK, Jetly V (1998) Inheritance pattern of salinity tolerance in rice. *J Genet Breed (Rome)* 52:325–331
- Mittler R (2006) Abiotic stress, the field environment and stress combination. *Trends Plant Sci* 11:15–19
- Moeljopawiro S, Ikehashi H (1981) Inheritance of salt tolerance in rice. *Euphytica* 30:291–300
- Moradi F, Ismail AM, Gregorio GB, Egdane JA (2003) Salinity tolerance of rice during reproductive development and association with tolerance at the seedling stage. *Ind J Plant Physiol* 8:105–116
- National Geographic Channel (2008) Six degrees could change the world. [www.youtube.com/watch?v=\\_s3ZK4-cEX4&feature=related](http://www.youtube.com/watch?v=_s3ZK4-cEX4&feature=related) (July 31, 2008)
- Ponnamperuma FN (1984) Role of cultivar tolerance in increasing rice production on saline lands. In: Staples RC, Toenniessen GH (eds) *Salinity tolerance in plants: strategies for crop improvement*. Wiley, New York, pp 255–271
- Rahman ML, Chu SH, Choi MS, Qiao YL, Jiang W, Piao R, Khanam S, Cho YI, Jeung JU, Jena KK, Koh HJ (2007) Identification of QTLs for some agronomic traits in rice using an introgression line from *Oryza minuta*. *Mol Cells* 24:16–26
- Rana RS (1986) Genetic evaluation and utilization: adverse soil tolerance. *Int Rice Res Newsl* 11(5):10
- Rao PS, Mishra B, Gupta SR, Rathore A (2008) Reproductive stage tolerance to salinity and alkalinity stresses in rice genotypes. *Plant Breed* 127:256–261
- Redoña ED, Nazareno FG, Laza MA, Toledo MCU (2008) Global rice germplasm exchange and impact on rice varietal development, p 76. *Abstr International Congress of Genetics*, Berlin, Germany
- Singh RK (1999) Genetic resources and the role of international collaboration in rice breeding. *Genome* 42:635–641
- Singh RK, Mishra B (1995) Screening  $F_1$  anther culture derivatives of rice for salt tolerance. In: Sharma B et al. (eds) *Genetic research and education: current trends and the next fifty years*. Indian Society of Genetics and Plant Breeding New Delhi. *Ind J Genet Plant Breed (special issue)*:509–513
- Singh RK, Mishra B (1997) Stable genotypes of rice for sodic soils. *Indian J Genet* 57:431–438
- Singh RK, Mishra B (2004) Role of Central Soil Salinity Research Institute in Genetic Improvement of Rice in India. In: Sharma SD and Prasad Rao U (eds) *Genetic improvement of rice varieties of India. Today and Tomorrow Printers and Publishers*, New Delhi, pp 189–242
- Singh RK, Mishra B, Senadhira D (1992) Promising salt tolerant  $F_1$  anther culture derivatives (ACDs). *Int Rice Res Newsl* 17:17
- Singh RK, Mishra B, Jetly V (2001) Segregations for alkalinity tolerance in three rice crosses. *SABRAO J* 33:31–34
- Singh RK, Mishra B, Chauhan MS, Yeo AR, Flowers SA, Flowers TJ (2002) Solution culture for screening rice varieties for sodicity tolerance. *J Agric Sci* 139:327–333
- Singh RK, Singh KN, Mishra B, Sharma SK, Tyagi NK (2004) Harnessing plant salt tolerance for overcoming sodicity constraints: an Indian experience. *Advances in sodic land reclamation*, pp 81–120. Concept Paper for the International Conference on “Sustainable Management of Sodic Soils”. February. Lucknow, India, pp 9–14
- Singh RK, Adorada DL, Magsino C, Roque Z, Tamayo N and Gregorio GB (2005) Temperature and relative humidity affect salinity tolerance in rice, page L-2. 10th International Congress of SABRAO, Tsukuba, Japan, 22-23 August. Abstract Proceeding
- Singh RK, Gregorio GB, Ismail AM (2008a) Breeding rice varieties with tolerance to salt stress. *J Indian Soc Coastal Agric Res* 26:16–21
- Singh RK, Redona E, Gregorio GB, Salam AM, Islam R, Singh DP, Sen P, Saha S, Mahata KR, Sharma SG, Pandey MP, Sajise AG, Mendoza R, Toledo MC, Dante A, Ismail AM, Paris T, Haeefe S, Thomson M, Zolviniski S, Singh YP, Nayak AK, Singh RB, Mishra VK, Sharma DK, Gautam RK, Ram PC, Singh PN, Verma OP, Singh A, Lang NT (2008b) Right rice in the right place: systematic exchange and farmer-centered evaluation of rice germplasm for salt-affected areas. In: Hoanh CT, Szuster B, Kam SP, Noble A, Ismail AM (eds) *Tropical deltas and coastal zones: community. Environment and Food Production at the Land-Water Interface*, CABI, Wallingford, UK
- Tanji KK (1990) Agricultural salinity assessment and management. In: Tanji KK (ed) *Manuals and Reports on Engineering Practice No 71*. American Society of Civil Engineers, New York, pp 1–17
- Toledo MCU, Alejar GPM, Nazareno FG, Redoña ED (2007) Sharing the world’s elite rice breeding and genetic resources. *Phillip J Crop Sci* 32(Suppl 1):126–127
- UPBSN (1999) Status Report: UP sodic lands reclamation project, p 53. UP Bhumi Sudhar Nigam (erstwhile UPLDC), Lucknow, India
- UPLDC (1995) Status Report: UP sodic lands reclamation project. Part I, UP Land Development Corporation, Lucknow, India 78 p
- US Census Bureau (1998) [www.census.gov/ipc/www/wp98001.html](http://www.census.gov/ipc/www/wp98001.html) (July 30, 2008)
- Vinebrooke RD, Cottingham KL, Norberg J, Scheffer M, Dodson SI, Maberly SC, Ulrich S (2004) Impacts of multiple stressors on biodiversity and ecosystem functioning: the role of species co-tolerance. *OIKOS* 104:451–457
- Virmani SS (2002) Progress and issues in development and use of hybrid rice in the tropics. [www.fao.org/docrep/006/y4751e/y4751e0g.htm](http://www.fao.org/docrep/006/y4751e/y4751e0g.htm) (July 31, 2008)
- Wang W, Vinocur B, Altman A (2007) Plant responses to drought, salinity and extreme temperatures towards genetic engineering for stress tolerance. *Planta* 218:1–14

- Wassmann F, Hien NX, Hoanh CT, Tuong TP (2004) Sea level rise affecting the Vietnamese Mekong Delta: water elevation in the flood season and implications for rice production. *Clim Change* 66:89–107
- Witcombe JR, Hollington PA, Howarth CJ, Reader S, Steele KA (2008) Breeding for abiotic stresses for sustainable agriculture. *Philos Trans R Soc Lon B Biol Sci* 363:703–716
- Yeo AR (1992) Variation and inheritance of sodium transport in rice. *Plant Soil* 146:109–116
- Yeo AR, Flowers TJ (1983) Varietal differences in the toxicity of sodium ions in rice leaves. *Physiol Plant* 59:189–195
- Yeo AR, Flowers TJ (1984) Mechanisms of salinity resistance in rice and their role as physiological criteria in plant breeding. In: Staples RC, Toenniessen GH (eds) *Salinity tolerance in plants: strategies for crop improvement*. Wiley, New York, pp 151–170
- Yeo AR, Flowers TJ (2006) Salinity resistance in rice (*Oryza sativa* L.) and a pyramiding approach to breeding varieties for saline soils. *Funct Plant Biol* 13:161–174
- Yeo AR, Yeo ME, Flowers SA, Flowers TJ (1990) Screening of rice (*Oryza sativa* L.) genotypes for physiological characters contributing to salinity resistance, and their relationship to overall performance. *Theor Appl Genet* 79:377–384
- Yoshida S, Forno DA, Cock JH, Gomez KA (1976) *Laboratory manual for physiological studies of rice*, 3rd edn. International Rice Research Institutes, Manila, Philippines, p 61
- Zeng L, Shannon MC, Grieve CM (2002) Evaluation of salt tolerance in rice genotypes by multiple agronomic parameters. *Euphytica* 127:235–245

# Chapter 19

## Transgenic Approaches

Anil K. Singh, Sudhir K. Sopory, Ray Wu<sup>#</sup>, and Sneh L. Singla-Pareek\*  
*Plant Molecular Biology,  
International Center for Genetic Engineering and Biotechnology,  
Aruna Asaf Ali Marg, New Delhi, 110 067, India*

<sup>#</sup>*Department of Molecular Biology and Genetics, Cornell University,  
316 Biotechnology Building, Ithaca, NY 14853, USA*

Summary .....	418
I Introduction .....	418
II Transgenic Approaches for Producing Abiotic Stress Tolerant Plants .....	419
A Engineering Genes for Stress Signaling.....	419
1 Sensors of Stress Signal .....	419
2 Downstream Signaling Cascades.....	420
B Engineering Genes of Transcriptional Regulation.....	422
1 Zinc Finger Proteins.....	423
2 Ethylene Responsive Element Binding Proteins (EREBPs) .....	424
3 Dehydration Responsive Element Binding Proteins/C-Repeat Binding Factors .....	425
4 MYB and MYC Transcription Factors.....	426
5 NAC Proteins .....	426
6 Other Transcription Factors and DNA/RNA Binding Proteins .....	427
C Engineering Genes for Redox Regulation .....	427
D Engineering Genes for Osmotic Regulation .....	429
E Engineering Genes for Cellular Protection .....	434
F Engineering Genes for Ionic Balance .....	435
III Future Perspectives .....	438
Acknowledgements .....	438
References .....	438

---

\*Author for Correspondence, e-mail: [sneh@icgeb.res.in](mailto:sneh@icgeb.res.in)



## Summary

The everyday deteriorating environmental factors such as extremes of temperature (high and low), water availability (drought and flooding), ion or physiological pH (salinity and alkalinity), UV light and anoxia pose deleterious effects on the survival and overall yield of the plants. Since, the abiotic stresses are multigenic as well as quantitative in nature, it is far more difficult to understand the response of the plants towards these stresses. Intensive efforts are being made worldwide employing physiological, biochemical and molecular tools to raise plants with improved suitability towards environmental stresses. With the advances in recent years towards identifying the genes that are regulated under stress, and sequencing of the whole plant genomes, research is being taken up actively to understand the molecular basis of abiotic stress responses and to manipulate these processes via genetic engineering. Employing transgenic technology, functional validation of various target genes, involved in diverse processes such as signal transduction, transcriptional regulation, ion homeostasis and antioxidant defense for various abiotic stresses has been attempted in various model systems. Some of these efforts have been extended to crop plants such as rice, maize, *Brassica*, wheat etc. This chapter presents a brief description of the transgenic studies that have been attempted with a view to understand the role of various genes which were indicated to be important, and transfer of some of these genes to crop plants for enabling them to survive under stress conditions.

**Keywords** ionic balance • osmotic regulation • redox • signaling cascade • stress tolerance • transgenic plant • transcription factor

## I Introduction

During their life cycle, plants are exposed to various unfavorable environmental conditions, such as drought, salinity, chilling, freezing, high temperature, flooding, high light and nutrient limitation, collectively known as abiotic stresses. Any of these stresses can adversely affect the growth and development, reduce productivity and in extreme

conditions cause the death of the plant (Levitt 1980). Because of their sessile nature, plants must endure abiotic stresses and consequently evolve a variety of strategies to acclimatize to these environmental variations. However, genotypic differences do exist among plant species in terms of tolerance against these abiotic stresses. Morphological, physiological, biochemical and molecular alterations in response to stress factors enable some plant species to sustain growth and development under stress conditions. Unfortunately, this is not the case for all the plants and in particular most of the agricultural crops, which countless people depend for survival. This situation is likely to worsen in view of climate change and global warming resulting in high temperature, drought and increased sea levels. Thus, efforts have been made to develop crop varieties that can not only withstand abiotic stresses, but can also maintain optimum yield levels. Screening of pre-existing genotypes in stressful environment has been attempted to explore the natural genetic variability. Conventional breeding approaches have been used to develop crop plants with improved abiotic stress tolerance, but with limited success only (Richards 1996). However, with the available

---

*Abbreviations:* ADC – arginine decarboxylase; AFP – antifreeze protein; AOX – alternative oxidase; CaM – calmodulin; CaN – calcineurin; CAT – catalase; CBF – CCAAT-binding factor; CDPK – calcium-dependent protein kinase; COD – choline oxidase; DHAR – dehydroascorbate reductase; DREB – dehydration-responsive element binding protein; EREBP – ethylene-responsive element binding protein; ERF – ethylene-responsive factor; GB – glycine betaine; Gly – glyoxalase; GPX – glutathione peroxidase; GSH – glutathione; GST – glutathione-S-transferase; LEA – late embryogenesis abundant protein; MAPK – mitogen activated protein kinase; ODC – ornithine decarboxylase; P5CS –  $\Delta^1$ -pyrroline-5-carboxylate synthetase; PA – polyamine; ROS – reactive oxygen species; SAMDC – S-adenosylmethionine decarboxylase; SOD – superoxide dismutase; SOS – salt overly sensitive; TF – transcription factor; UDP – uridine diphosphate; ZFP – zinc finger protein

knowledge obtained through genome level studies, and advent of biotechnological tools and techniques, generation of transgenic plants with improved tolerance to abiotic stresses has brought some hope for sustainable agriculture under harsh environmental conditions. In this chapter, we briefly describe the current status of various strategies, particularly the genetic engineering of regulatory genes including transcription factors, osmoprotectants, reactive oxygen species (ROS) scavengers, ion transporters and water channels, detoxification enzymes and stress associated proteins, for imparting abiotic stress tolerance in plants.

## II Transgenic Approaches for Producing Abiotic Stress Tolerant Plants

Many plants have multiple physiological, biochemical and molecular mechanisms that enable them to tolerate environmental stresses. Understanding of these mechanisms and their engineering using molecular biology and genomic approaches provides enormous possibilities for improving abiotic stress tolerance in plants. Several efforts in this direction have been carried out in many laboratories targeting manipulation of genes belonging to diverse categories. Recently, a number of reviews have been compiled on the elucidation of stress tolerance mechanisms and use of transgenic technology for developing abiotic stress tolerant crop plants (Singla-Pareek et al. 2001; Zhu 2001, 2002; Bajaj and Mohanty 2005; Rodriguez et al. 2005; Vinocur and Altman 2005; Yamaguchi and Blumwald 2005; Sahi et al. 2006; Gao et al. 2007; Vij and Tyagi, 2007; Singh et al. 2008). In addition to using the potential of known genes for developing stress tolerant transgenic plants, detailed analysis towards understanding of abiotic stress tolerance mechanisms using molecular biology and genomics approaches is also required.

### A Engineering Genes for Stress Signaling

Environmental stresses disrupt virtually all aspects of plant physiology and metabolism which may lead to death of the plant. Abiotic stress tolerance depends on prevention or alleviation of cellular damage, re-establishment of homeostatic conditions

under stressful environment and resumption of growth (Zhu 2001). Plants being sessile in nature cannot escape the adverse environmental conditions, therefore they have evolved mechanisms to perceive stress signal and to switch on the protective machinery resulting in proper physiological morphological, biochemical and molecular changes. At the molecular level, the perception of extra-cellular stimuli and the activation of protective machinery require a complex interplay of signaling cascades (Xiong and Yang 2003).

### 1 Sensors of Stress Signal

The first step in switching on any molecular response is the perception of stress and then to relay information about it through a signal transduction pathway. To perceive the initial stress signal, a sensor molecule is required that initiates (or suppress) a cascade to transmit the signal intracellularly and in many cases, activate nuclear transcription factors to induce the expression of specific sets of genes. Specificity in signaling is easy to envision if each stress signal has a sensor that can specifically transduce the signal to cellular targets. At present only few stress sensors have been identified and there is limited information to assess whether crosstalk occurs at the sensor level (Chinnusamy et al. 2004). The two-component sensor-response regulator systems involving histidine kinases that were initially identified in prokaryotes for the perception of various environmental signals also exist in eukaryotes, including plants. When the extracellular sensor domain perceives a signal, the cytoplasmic histidine residue is autophosphorylated and the phosphoryl moiety is then passed to an aspartate receiver in a response regulator, which may constitute part of the sensor protein or a separate protein. The sensors may couple with a downstream mitogen-activated protein kinase (MAPK) cascade or directly phosphorylate specific targets to initiate cellular responses. Upon receiving a signal from membrane receptors, cells often utilize multiple phosphoprotein cascades to transduce and amplify the information (Rodriguez et al. 2005; Pareek et al. 2006).

The transmembrane two-component histidine kinases, HIK33 in cyanobacterium and DesK in *Bacillus subtilis* have been suggested as thermosensors (Suzuki et al. 2000; Aguilar et al. 2001).

In plants, no molecule has been identified as a thermo-sensor as yet (Samach and Wigge 2005). In yeast, an osmosensory histidine kinase SLN1 senses osmotic stress and activates the HOG1 (high-osmolarity glycerol response 1) MAPK cascade (Maeda et al. 1994). An *Arabidopsis* histidine kinase (*AtHK1*) cDNA has been identified based on stress inducibility of its transcript and ability to complement *sln1-ts*, a yeast mutant defective in osmosensing. The histochemical analysis of  $\beta$ -glucuronidase activity driven by *AtHK1* promoter further indicated that this gene is transcriptionally upregulated in response to changes in external osmolarity. This study demonstrated *AtHK1* as candidate osmosensor (Urao et al. 1999). Recently, microarray analysis of the *ahk1* mutant revealed down regulation of many stress- and/or ABA-inducible genes, such as *AREB1*, *ANAC* and *DREB2A* transcription factors and their downstream genes, suggesting that AHK1 functions upstream of these genes and positively controls stress responses through both ABA-dependent and ABA-independent signaling pathways (Tran et al. 2007).

Heat shock transcription factors (Hsfs) have been shown to act as direct sensors of ROS in mammals, *Drosophila* and yeast. In plants, promoter of the central  $H_2O_2$ -scavenging enzyme, cytosolic ascorbate peroxidase 1 (Apx1) as well as promoters of many defense genes and transcription factors involved in  $H_2O_2$  signaling and defense, contain Hsf binding motif (Mittler and Zilinskas 1992; Rizhsky et al. 2004; Davletova et al. 2005a). Further, studies have supported the hypothesis that Hsfs could function as  $H_2O_2$  sensors in plants (Miller and Mittler 2006).

Some receptor-like kinases (RLKs) have been implicated in abiotic stress responses. Transgenic analysis has shown that wound, salt and osmotic stresses induce a putative membrane-localized receptor-like protein C7 (*NtC7*) in tobacco. *NtC7* has been shown to exhibit an important role in osmotic stress tolerance (Tamura et al. 2003). Determination of the in vivo role of higher plant putative sensory kinases and the identification of signaling intermediates and their targets will be required to determine whether sensor kinase signaling is specific or involves crosstalk between different stress signaling pathways (Chinnusamy et al. 2004).

## 2 Downstream Signaling Cascades

Various components of abiotic stress signal transduction pathway have been identified and studied (Zhu 2001, 2002; Xiong et al. 2002; Apel and Hirt 2004) and these can be grouped into three major signaling types: (a) osmotic/oxidative stress signaling that uses MAPK modules, which involve the production of ROS scavenging enzymes and antioxidant compounds for redox regulation as well as osmolytes for osmotic regulation; (b)  $Ca^{2+}$  dependent signaling involving  $Ca^{2+}$  binding protein that lead to the activation of late embryogenesis abundant (LEA) type genes involving the production of stress responsive proteins mostly of undefined functions and (c)  $Ca^{2+}$  dependent salt overly sensitive (SOS) signaling for maintaining ion balance (Rodriguez et al. 2005) (Fig. 1). Potential of engineering these signaling pathway components for achieving abiotic stress tolerance has been shown using various plant species.

### Protein Kinases

MAP-kinase cascades transfer information from sensors to cellular responses in all eukaryotes including plants. This phosphorylation cascade typically consists of three functionally interlinked protein kinases: a MAP kinase kinase kinase (MAPKKK), a MAP kinase kinase (MAPKK) and a MAP kinase (MAPK). In this phosphorylation module, a MAPKKK phosphorylates and activates a particular MAPKK, which in turn phosphorylates and activates a MAPK. Activated MAPK is imported into the nucleus where it phosphorylates and activates specific downstream signaling components such as transcription factors (Khokhlatchev et al. 1998). In plants, several components of the MAPK cascade have been identified and characterized and shown to be involved in stress signaling, including cold, drought, salinity, wounding, heavy metal, jasmonic acid, oxidative stress and plant-pathogen interaction (Sanan-Mishra et al. 2006). Hydrogen peroxide ( $H_2O_2$ ) has been shown to activate a specific *Arabidopsis* MAPKKK (ANP1), which initiates a phosphorylation cascade involving two stress-responsive MAPKs, *AtMPK3* and *AtMPK6*. Constitutively expressed *ANP1* mimics the  $H_2O_2$  effect and initiates the MAPK cascade that induces specific stress responsive genes. Transgenic tobacco plants, constitutively over-expressing tobacco *NPK1*, an

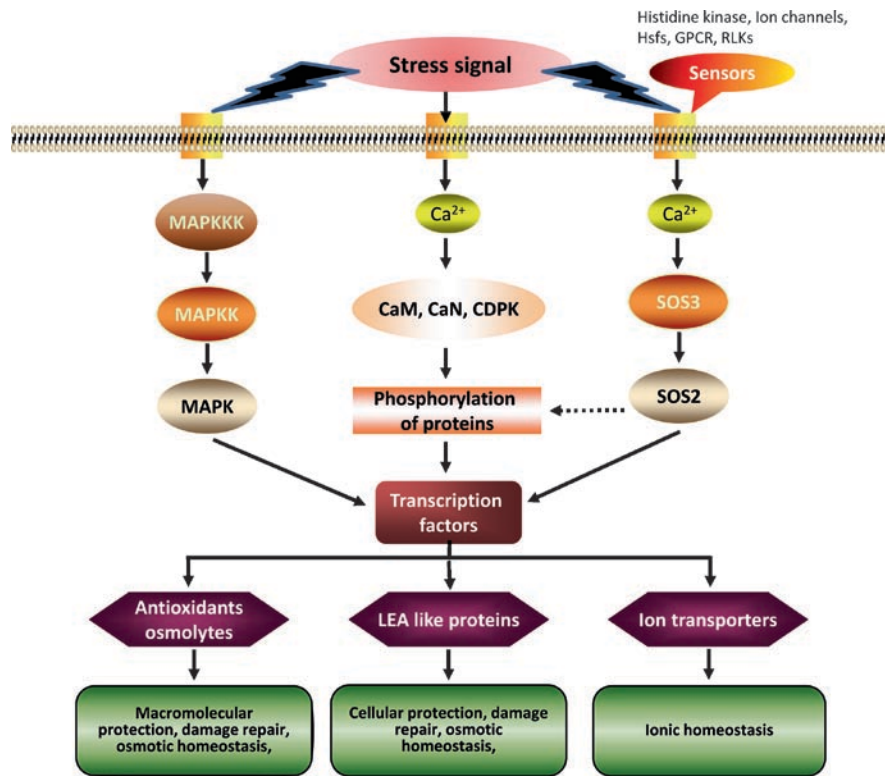

*Fig. 1.* Signal transduction pathways involved in abiotic stress responses. Stress signal is perceived through sensor(s) and the signal is transduced to the intracellular targets. Hyperosmolarity caused due to salinity and drought stress activates MAPK cascade which serves as a link between upstream receptors and downstream signaling components such as transcription factors to induce cellular response. Abiotic stress signal also initiates  $\text{Ca}^{2+}$  signal that causes activation of  $\text{Ca}^{2+}$ -binding proteins, such as CaM, CaN and CDPK. These  $\text{Ca}^{2+}$ -binding proteins phosphorylate and activate the transcription factors, which mediate cellular responses.  $\text{Ca}^{2+}$  signal also induce SOS signaling pathway which is required for ion homeostasis [See Color Plate 11, Fig. 18].

orthologue of *ANP1*, display enhanced tolerance to multiple environmental stresses such as, heat, freezing, drought and salt (Kovtun et al. 2000). Further, constitutive over-expression of *NPK1* has been shown to confer freezing tolerance in maize, which is otherwise a frost sensitive species (Shou et al. 2004). In another study, the *Arabidopsis* MAP kinase kinase 2 (*MKK2*) and the downstream MAPKs, *MPK4* and *MPK6* were isolated. *Arabidopsis* plants, over-expressing *MKK2* exhibited constitutive *MPK4* and *MPK6* activity and conferred freezing and salt tolerance (Teige et al. 2004).

Calcium-dependent protein kinase (CDPK) plays important role in  $\text{Ca}^{2+}$  dependent signaling. CDPKs are activated by the binding of  $\text{Ca}^{2+}$  to their calmodulin-like domain, but are not stimulated by calmodulin. A rice gene encoding CDPK (*OsCDPK7*) was over-expressed in rice under

the control of *CaMV35S* promoter and found that transgenic plants were more tolerant to salt, drought and cold than the non-transgenic plants (Saijo et al. 2000). The rice CDPK13 (*OsCDPK13*) has been reported to be involved in cold stress response in rice (Abbasi et al. 2004). Transgenic rice plants over-expressing *OsCDPK13* were shown to have higher cold tolerance than non-transgenic plants (Komatsu et al. 2007).

#### Calcium-Dependent Proteins

$\text{Ca}^{2+}$  has been established as an important secondary messenger in all eukaryotic cells in triggering physiological changes in response to external stimuli, especially in mediating environmental stress signal perception and transduction in plants (Poovaiah and Reddy 1987; Yang and Poovaiah 2003). An unique combination of  $\text{Ca}^{2+}$ -binding proteins must be activated to respond to a specific



cytosolic free  $\text{Ca}^{2+}$  ( $[\text{Ca}^{2+}]_c$ ) perturbation. These ( $[\text{Ca}^{2+}]_c$ ) sensors include calmodulin (CaM), CaM-like proteins, calcineurin B-like (CBL) proteins and  $\text{Ca}^{2+}$ -dependent protein kinases (CDPKs). These proteins bind  $\text{Ca}^{2+}$  using a helix-loop-helix structure termed 'EF hand', which binds a single  $\text{Ca}^{2+}$  molecule with high affinity (White and Broadley 2003).

CaM is the best characterized  $\text{Ca}^{2+}$  binding protein and its role in  $\text{Ca}^{2+}$  signal transduction has been widely investigated (Reddy 2001; Snedden and Fromm 2001). Recently, one of the isoforms of CaM was found to bind to a transcription factor MYB2, enhancing its DNA binding activity. Over-expression of this isoform of CaM in *Arabidopsis* conferred salt tolerance by up-regulation of transcription of the MYB2 regulated genes including  $\Delta^1$ -pyrroline-5-carboxylate synthetase1 (*P5CS1*), a rate-limiting enzyme in proline biosynthesis (Yoo et al. 2005).

Another  $\text{Ca}^{2+}$  binding protein, Calcineurin (CaN) has been shown to have multiple functions in cells including regulation of ion homeostasis. CaN is a  $\text{Ca}^{2+}$  and calmodulin-dependent serine/threonine phosphatase (PP2B) that is an integral intermediate of a salt stress signal transduction pathway in yeast, which affects NaCl tolerance through the regulation of  $\text{Na}^+$  influx and efflux (Mendoza et al. 1996). A truncated form of the catalytic subunit and the regulatory subunit of yeast CaN were co-expressed in transgenic tobacco plants to reconstitute, in vivo, a constitutively active phosphatase. Transgenic lines expressing activated CaN exhibited substantial NaCl tolerance (Pardo et al. 1998). Recently, in rice a truncated form of the catalytic subunit of mouse CaN was expressed and found that transgenic plants had higher salt tolerance than the non-transgenic plants. Protective mechanism of CaN against salinity stress was through inhibition of  $\text{Na}^+$  accumulation in root cells (Ma et al. 2005).

#### SOS Signaling

The calcium dependent salt overly sensitive (SOS) signaling pathway is specific for the ionic aspect of salt stress. Salt stress elicits a cytosolic calcium signal, which is perceived by SOS3 (a myristoylated calcium-binding protein) and translates it to downstream responses. SOS3 interacts with and activates SOS2 (a serine/threonine protein kinase).

SOS2 and SOS3 regulate the expression level of SOS1, a salt tolerance effector gene encoding a plasma membrane  $\text{Na}^+/\text{H}^+$  antiporter (Zhu 2002) (Fig. 2). SOS1 itself can slightly increase the salt tolerance of a yeast mutant strain lacking all endogenous  $\text{Na}^+$ -ATPase and  $\text{Na}^+/\text{H}^+$  antiporters (Shi et al. 2002). Over-expression of SOS1 (Shi et al. 2002) and activated form of SOS2 (Guo et al. 2004a) conferred improved salt tolerance to transgenic *Arabidopsis* plants. Katiyar-Agarwal et al. (2006) have shown that SOS1 interacts with RCD1 (radical-induced cell death) and functions in oxidative stress tolerance in *Arabidopsis*. Recently, SOS1 signaling pathway in rice has been identified and characterized. Rice CBL protein-interacting protein kinase, *OsCIPK24* and *OsCBL4* were found to act coordinately to activate *OsSOS1* in yeast cells and they could be exchanged with their *Arabidopsis* counterparts to form heterologous protein kinase modules that activated both *OsSOS1* and *AtSOS1* and suppressed the salt sensitivity of *sos2* and *sos3* mutants of *Arabidopsis*. This study showed that SOS salt tolerance pathway also operates in rice and it shares a high degree of structural and functional conservation between rice and *Arabidopsis* (Martinez-Atienza et al. 2007). A *Populus euphratica* SOS1 (*PeSOS1*) has been identified and its expression suppressed the salt sensitivity of a salt sensitive mutant of the EP432 strain of *E. coli*, which lacks the activity of the two  $\text{Na}^+/\text{H}^+$  antiporters *EcNhaA* and *EcNhaB* (Wu et al. 2007b).

#### B Engineering Genes of Transcriptional Regulation

The transcriptional rate of any target gene is enhanced or repressed by binding of the transcription factors (TFs) that are sequence-specific DNA-binding proteins to specific promoter regions (i.e. cis-acting elements) upon activation or de-activation of upstream signaling cascades (Fig. 3). TFs thus constitute master control elements of dynamic transcriptional networks. In plants, TFs have been employed to manipulate various types of metabolic, developmental and stress response pathways. In this section we have discussed the reports targeting over-expression of the transcription factors to enhance abiotic stress tolerance in plants.

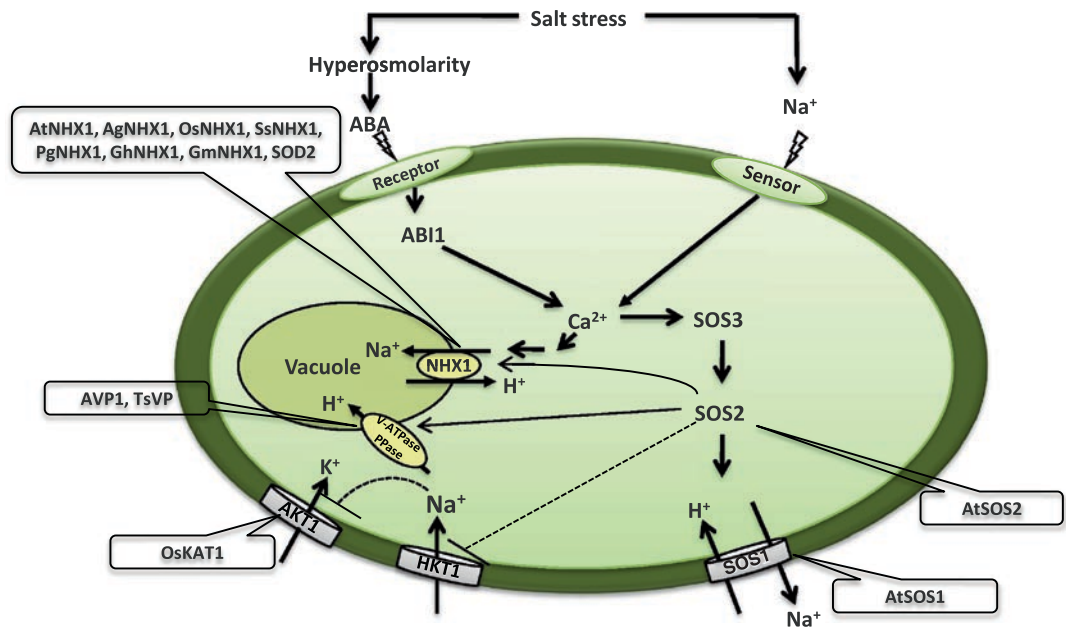

Fig. 2. Regulation of ionic balance in plant cell through  $\text{Ca}^{2+}$  mediated signal transduction pathways. Excessive  $\text{Na}^+$  and hyperosmolarity are perceived by unknown sensors. Hyperosmolarity causes induction of ABA synthesis which up-regulates the expression of *NHX1* mediated by *ABI1* and  $\text{Ca}^{2+}$ .  $\text{Na}^+$  stress initiates a  $\text{Ca}^{2+}$  signal that activates the SOS3-SOS2 protein kinase pathway, which stimulates the activity of a plasma membrane  $\text{Na}^+/\text{H}^+$  antiporter SOS1. SOS3-SOS2 complex may also mediate the regulation of activities of other transporters involved in ion homeostasis, such as vacuolar  $\text{H}^+$ -ATPase, vacuolar pyrophosphatase (PPase), vacuolar  $\text{Na}^+/\text{H}^+$  exchanger and plasma membrane  $\text{K}^+$  and  $\text{Na}^+$  transporters. Genes coding for ion transporters, which have been over-expressed in transgenic plants are shown in dialogue boxes.

### 1 Zinc Finger Proteins

Zinc-finger proteins (ZFPs) play important role in growth and development in both animals and plants. The term 'zinc-finger' represents the sequence motifs in which cysteines and/or histidines coordinate zinc atom(s) to form local peptide structures that are required for their specific functions. Cys2/His2 (C2H2)-type ZFPs, which contain the EAR transcriptional repressor domain, are thought to play a key role in regulating the defense response of plants to biotic and abiotic stress conditions. Winicov and Bastola (1999) have reported that over-expression of *Alfin1* gene, which codes for a novel member of the ZFP family confers salt tolerance to the transgenic Alfalfa plants. A cold-inducible cDNA encoding (C2H2)-type ZFP, *SCOF-1* was isolated from soybean and its constitutive over-expression induced cold-regulated (COR) gene expression and

enhanced cold tolerance of non-acclimated transgenic *Arabidopsis* and tobacco plants (Kim et al. 2001). A petunia gene *ZPT2-3* encoding C2H2-type ZFP, when constitutively over-expressed in petunia, conferred dehydration tolerance in transgenic plants (Sugano et al. 2003). An intronless gene *OSISAP1* from rice encoding a zinc-finger protein, which is inducible by different types of stresses, namely cold, desiccation, salt, submergence and heavy metals as well as injury was isolated and characterized. Over-expression of this gene in tobacco conferred cold, dehydration and salt tolerance at the seed germination/seedling stages (Mukhopadhyay et al. 2004). Sakamoto et al. (2004) analyzed the function of gene encoding four different ZPT2 (C2H2 type ZFP) related proteins (AZF1, AZF2, AZF3 and STZ) and reported that these proteins act as transcriptional repressor that down-regulate the trans-activation activity of other transcription factors. Transgenic

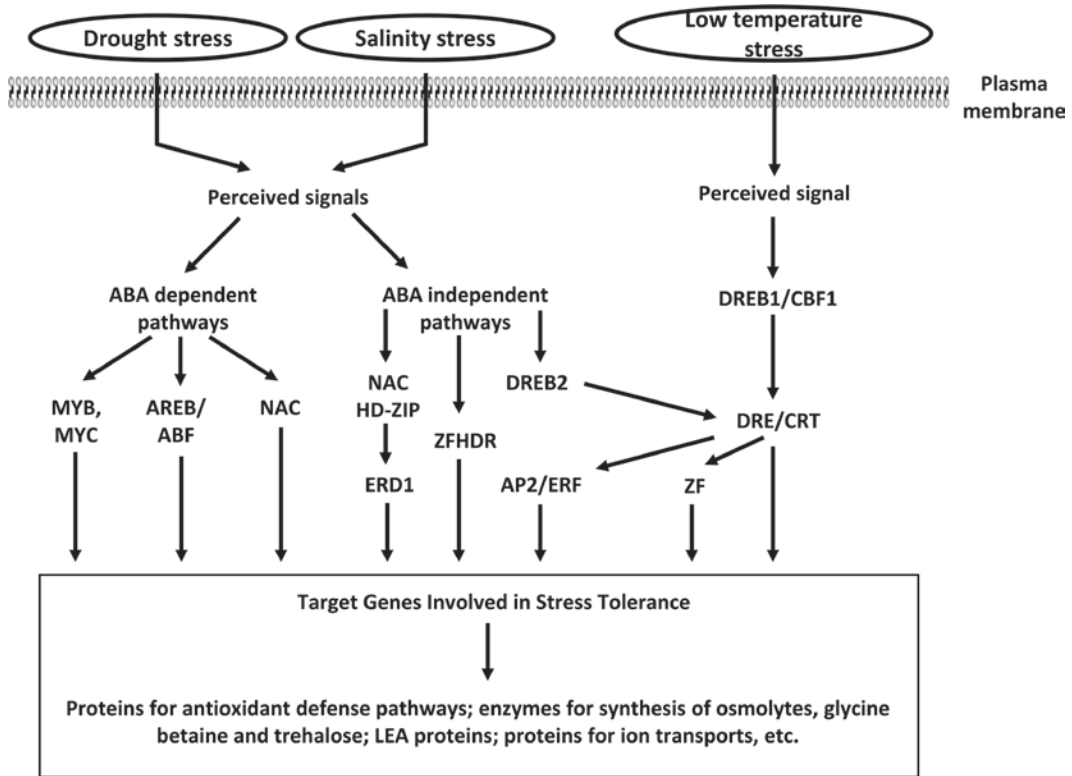

Fig. 3. Conceptual network of signal transduction pathways involved in salinity, drought and low temperature stresses in plants. Stress signal is perceived by sensors and transduced to the cellular targets. Salinity and drought stress signal transduction involve ABA-dependent and ABA-independent pathways, which affect the expression of transcription factors. Transcription factors bind to cis-acting elements and enhance or repress the transcription of their target genes.

*Arabidopsis* plants over-expressing STZ showed growth retardation and tolerance to drought stress. These results suggest that AZF2 and STZ function as transcriptional repressors to increase stress tolerance following growth retardation. The zinc-finger protein *Zat12* responds to a large number of biotic and abiotic stresses. Transcriptional profiling of *Zat12* over-expressing plants and wild-type plants subjected to  $H_2O_2$  stress revealed that constitutive expression of *Zat12* in *Arabidopsis* resulted in the enhanced expression of oxidative- and light stress responsive transcripts, suggesting that *Zat12* plays a central role in reactive oxygen and abiotic stress signaling in *Arabidopsis* (Davletova et al. 2005b). The constitutive expression of C2H2-type ZFPs enhanced tolerance to abiotic stresses, however the growth of transgenic plants was suppressed. The role of EAR motif in C2H2-type ZFP, *Zat7* was determined by Ciftci-Yilmaz et al. (2007). Transgenic

*Arabidopsis* plants constitutively expressing the *Zat7* exhibited suppressed growth and were more tolerant to salinity stress. A deletion or a mutation of the EAR-motif of *ZAT7* abolishes salinity tolerance without affecting growth suppression. These results demonstrate that the EAR-motif of *Zat7* is directly involved in enhancing the tolerance of transgenic plants to salinity stress. In contrast, the EAR-motif does not appear to be involved in growth suppression of transgenic plants. Further analysis of *Zat7* using RNA interference (RNAi) lines suggests that *Zat7* functions in *Arabidopsis* to suppress a repressor of defense responses.

## 2 Ethylene Responsive Element Binding Proteins (EREBPs)

EREBPs contain a highly conserved basic DNA-binding domain (AP2/ERF domain) comprising 58 or 59 amino acids. The AP2/ERF domain

recognizes and binds to *cis*-elements such as the DRE/CRT element and GCC-box (Gutterson and Reuber 2004). A salt-inducible transcript, with significant sequence homology with an *EREBP/AP2* DNA binding motif from oilseed rape plant was isolated. With this cDNA fragment as a probe, cDNA clone *Tsi1* (Tobacco stress-induced gene1) was isolated from a tobacco cDNA library. Transgenic plants over-expressing *Tsi1* exhibited higher expression of several pathogenesis-related (PR) genes under normal conditions, resulting in improved tolerance to salt and pathogens (Park et al. 2001). Osmotin promoter binding protein 1 (*OPBP1*), an AP2/EREBP-like transcription factor of tobacco was isolated using yeast one-hybrid system. Transgenic tobacco plants over-expressing *OPBP1* gene accumulated high levels of *PR-1a* and *PR-5d* and exhibited enhanced resistance to infection by *Pseudomonas syringae*, and *Phytophthora parasitica* pathogens alongwith higher degree of tolerance to salt stress (Guo et al. 2004b). An *Arabidopsis* EREBP (*AtEBP*) gene was isolated and its over-expression in transgenic tobacco plants suppressed Bax-induced cell death. Furthermore, tobacco BY-2 cells over-expressing *AtEBP* conferred resistance to H<sub>2</sub>O<sub>2</sub> and heat treatments (Ogawa et al. 2005). Recently, an *EREBP1* gene from potato (*StEREBP1*) was over-expressed in transgenic potato plants and shown that transgenic plants had higher degree of cold and salt stress tolerance than non-transgenic plants (Lee et al. 2007a). These studies suggest that EREBP1 is a functional transcription factor that seems to be involved in two separate signal transduction pathways under abiotic and biotic stresses.

Ethylene-responsive factors (ERFs) are plant-specific transcription factors and play important roles in regulating gene expression under abiotic and biotic stresses. There is increasing evidence that ERF proteins integrate the interaction of different signal transduction pathways under biotic and abiotic stress conditions. A cDNA, designated as jasmonate and ethylene-responsive factor (*JERF1*) from tomato was over-expressed in tobacco and it was found that transgenic plants exhibited higher expression of GCC-box-containing genes such as osmotin, GLA, Prb-1b and CHN50 under normal growth conditions, and subsequently resulted in enhanced tolerance to salt stress (Zhang et al. 2004). Similarly, tomato

*TERF1* (Huang et al. 2004) and *JERF3* (Wang et al. 2004a), ERF-like protein of hot pepper (*CaERFLP1*) (Lee et al. 2004a), wheat ERF1 (*TaERF1*) (Xu et al. 2007), and barley ERF (*HvRAF*) (Jung et al. 2007) also bind to GCC box and DRE. Their over-expression in transgenic plants activated the expression of GCC box-containing PR genes and exhibited higher tolerance to salt stress than non-transgenic plants. Wu et al. (2007a) have shown that *JERF1* interact with multiple *cis*-acting elements and activate the expression of stress responsive and ABA biosynthesis-related genes, consequently enhancing ABA biosynthesis, and ultimately enhancing the tolerance and growth of the transgenic tobacco plants under high salinity and low temperature. Recently, a *HARDY* (HRD) gene, which codes for an AP2/ERF-like transcription factor has been identified from a gain-of-function *Arabidopsis* mutant. Expression of *HRD* gene in rice improved water use efficiency, and these drought-tolerant, low-water-consuming rice plants exhibit increased shoot biomass under well irrigated conditions and an adaptive increase in root biomass under drought stress (Karaba et al. 2007). These results suggest that *ERFs* modulate osmotic tolerance by activation of downstream gene expression through interaction with the GCC box and/or DRE and could be potential candidate genes for engineering biotic and abiotic stress tolerance in plants.

### 3 Dehydration Responsive Element Binding Proteins/C-Repeat Binding Factors

The DRE (dehydration-responsive element)/CRT (C-repeat) was identified as a *cis*-acting element regulating gene expression in response to dehydration (salt, drought and cold stresses) in *Arabidopsis* (Yamaguchi-Shinozaki and Shinozaki 1994). TFs DREB1/CBF1-3, CBF4 and DREB2, have been shown to bind to DRE/CRT elements (Stockinger et al. 1997; Liu et al. 1998; Haake et al. 2002; Yamaguchi-Shinozaki and Shinozaki 2005). To augment abiotic stress tolerance in plants, various *DREB* genes have been over-expressed in a wide range of plants (Agarwal et al. 2006). However over-expression of *DREB/CBF* from wheat (Shen et al. 2003) and *Arabidopsis* (Lee et al. 2004b) was attempted in rice, but the level of stress tolerance could not be achieved and transgenic plants showed growth retardation



under normal conditions. This phenotype could be corrected and abiotic stress tolerance achieved in rice by over-expressing *Arabidopsis* *CBF3/DREB1* and *ABF3* gene under the control of constitutive maize ubiquitin promoter (Oh et al. 2005). Recently, several transgenic rice lines were generated over-expressing *OsDREB1A* and *OsDREB1B* from rice and *DREB1A*, *DREB1B* and *DREB1C* from *Arabidopsis* under the control of constitutive ubiquitin promoter. The transgenic plants were more tolerant to salt, low temperature and drought conditions, but their growth was retarded under normal conditions. However, stress inducible expression of the transgene recovered normal vegetative growth, which suggests that fine-tuning of expression of these genes is required (Ito et al. 2006).

#### 4 MYB and MYC Transcription Factors

Among many genes involved in transcriptional regulation in plants, *CI* gene from maize was the first to be isolated and extensively characterized. The maize *CI* gene regulates the expression of structural genes that are involved in the biosynthesis of anthocyanin during seed development, and it encodes a putative protein with the conserved DNA binding domain of the c-myc proto-oncogene (Paz-Ares et al. 1987). It has been reported that both the rd22BP1 (MYC) and AtMYB2 (MYB) proteins function as transcriptional activators in the dehydration- and ABA-inducible expression of the *rd22* gene (Abe et al. 1997). Transgenic *Arabidopsis* over-expressing *AtMYC2* and/or *AtMYB2* cDNAs have higher sensitivity to ABA and their microarray analysis revealed that several ABA-inducible genes were up-regulated in transgenic plants. Transgenic plants had reduced electrolyte leakage than non-transgenic plants under increasing concentrations of mannitol and exhibited improved abiotic stress tolerance (Abe et al. 2003). A *BOS1* (BOTRYTIS SUSCEPTIBLE1) gene, coding for *R2R3MYB* transcription factor protein was isolated from *Arabidopsis* on the basis of a T-DNA insertion allele that resulted in increased susceptibility to Botrytis infection. Strikingly *bos1* (mutant) plants showed impaired tolerance to water deficit, salinity and oxidative stress, suggesting that *BOS1* mediates responses to signals, possibly mediated by reactive oxygen intermediates from

both biotic and abiotic stress agents (Mengiste et al. 2003). A MYB transcription factor-coding gene *CpMYB10* was isolated from a resurrection plant *Craterostigma plantagineum* and its over-expression in *Arabidopsis* led to desiccation and salt tolerance in transgenic plants (Villalobos et al. 2004). An *Arabidopsis* *AtMYB60* gene coding for R2R3MYB protein has been reported to be the first transcription factor involved in the regulation of stomatal movements, which is specifically expressed in guard cells and its expression is negatively modulated during drought. A null mutation in *AtMYB60* results in the constitutive reduction of stomatal opening and in decreased wilting under water stress conditions (Cominelli et al. 2005). Over-expression of *Arabidopsis* *MYB2* gene in *japonica* rice under the control of ABA-inducible promoter conferred salt stress tolerance in transgenic rice plants (Malik and Wu 2005).

#### 5 NAC Proteins

The NAC domain was first characterized from consensus sequences from petunia NAM and from *Arabidopsis* ATAF1, ATAF2, and CUC2 (Aida et al. 1997). Fujita et al. (2004) reported that *Arabidopsis* *RD26* cDNA, which was originally identified from dehydrated plants, encode a NAC protein. Transgenic *Arabidopsis* plants over-expressing *RD26* were highly sensitive to ABA, while *RD26* repressed plants were insensitive. Microarray analysis showed that ABA- and stress-inducible genes were up-regulated in the *RD26* over-expressing plants and down-regulated in the *RD26* repressed plants. A rice NAC gene *SNAC1* (stress-responsive NAC1), which was induced by drought and salinity predominantly in guard cells was over-expressed in transgenic rice plants, which exhibited significantly improved drought resistance under field conditions and strong tolerance to salt stress (Hu et al. 2006). Recently, abiotic stress inducible rice NAC gene (*OsNAC6*) was identified and its over-expression in rice conferred tolerance to dehydration and high salt stress in transgenic plants (Nakashima et al. 2007). Microarray analysis of *OsNAC6* over-expressing transgenic rice plants revealed that many genes that are inducible by abiotic and biotic stresses were up-regulated. These results suggest that *OsNAC6* functions as a transcriptional

activator in response to abiotic and biotic stresses in plants.

### 6 Other Transcription Factors and DNA/RNA Binding Proteins

Besides members of above mentioned transcription factor families, several other TF-encoding genes have also been over-expressed to achieve abiotic stress tolerance in plants. Use of different ABA mutants has defined the presence of distinct ABA-mediated and ABA-independent pathways controlling the expression of several stress responsive genes. Ectopic expression of a seed specific transcriptional activator- *ABI3* gene confers the enhanced ability to accumulate seed-specific transcripts (such as *RAB18* and *LTI78*) in response to ABA, and also influences some ABA mediated vegetative responses in *Arabidopsis* plants. The enhanced expression of these genes in the transgenic plants was correlated with increased tolerance to freezing stress as well as enhanced responsiveness to ABA (Tamminen et al. 2001). Over-expression of ABRE binding factors *ABF3* and *ABF4* in transgenic *Arabidopsis* plants results in ABA hypersensitivity and other ABA-associated phenotype. In addition, the transgenic plants exhibited reduced transpiration and enhanced drought tolerance (Kang et al. 2002). A novel pathogen-induced gene encoding the RAV (related to ABI3/VP1) TF, *CARAV1* was isolated from pepper leaves and its ectopic expression in transgenic *Arabidopsis* plants conferred tolerance to osmotic stress caused by high salinity and dehydration (Sohn et al. 2006). An *Arabidopsis* multiprotein bridging factor 1a (*MBF1a*) transcriptional coactivator gene was cloned from maize kernel cDNA library. Constitutive expression of *MBF1a* in *Arabidopsis* led to elevated salt tolerance in transgenic lines (Kim et al. 2007). Recently, a TF from the nuclear factor Y (NF-Y) family from *Arabidopsis* has been identified (AtNF-YB1), which acts through a previously undescribed mechanism to confer improved performance in *Arabidopsis* under drought conditions. In the same study an orthologue of maize TF, ZmNF-YB2 is also shown to have an equivalent activity. Transgenic maize plants over-expressing *ZmNF-YB2* showed tolerance to water limiting conditions (Nelson et al. 2007).

DNA helicases which are the motor proteins catalyzing the unwinding of duplex DNA in an ATP-dependent manner have also been shown to be associated with abiotic stresses. Plant DNA helicase (PDH 45) was shown to be induced in pea seedlings in response to high salt and its over-expression under constitutive CaMV35S promoter in tobacco conferred enhanced salinity tolerance (Sanan-Mishra et al. 2005). The exact mechanism of PDH 45-mediated salinity tolerance is not yet understood. However, based on its properties it was suggested that there may be two sites of action: (a) it may act at the translation level to enhance or stabilize protein synthesis, or (b) it may associate with DNA multisubunit protein complexes to alter the gene expression.

With the availability of whole genome sequences of *Arabidopsis* and rice several novel stress-responsive transcription factors have also been identified which could provide new opportunities to study the regulation of gene expression in plants under stress conditions (Iida et al. 2005; Wu et al. 2006; Gao et al. 2006b; Riano-Pachon et al. 2007).

### C Engineering Genes for Redox Regulation

A wide range of environmental stresses cause enhanced production of reactive oxygen species (ROS) such as superoxide, hydrogen peroxide, and hydroxyl radicals within several sub-cellular compartments of the plant cell. ROS can be extremely reactive and oxidize biological molecules such as DNA, proteins and lipids (Breusegem et al. 2001). For redox regulation and to protect cells under stress conditions, plants induce antioxidant system involving ROS scavenging enzymes (SOD, CAT, peroxidase and glutathione peroxidase), detoxifying lipid peroxidation products (glutathione S-transferase, phospholipid-hydroperoxide, glutathione peroxidase, and ascorbate peroxidase) and a network of low molecular mass antioxidants (ascorbate, glutathione, phenolic compounds and tocopherols). In addition, a whole array of enzymes is needed for the regeneration of the active forms of the antioxidants (monodehydroascorbate reductase, dehydroascorbate reductase and glutathione reductase) (Blokchina et al. 2003).

Transgenic plants over-expressing genes encoding any of these antioxidants have been found to exhibit enhanced abiotic stress tolerance. Enhanced formation of ROS under stress conditions induces both protective responses and cellular damage. In the ROS scavenging process, SOD is the first line of defense, which converts superoxide radical to  $H_2O_2$  (Scandalios 1993). Over-expression of various isoforms of *SOD* has been attempted and found to act as a safeguard against high temperature (Gupta et al. 1993a), low temperature (Gupta et al. 1993b; McKersie et al. 1993, 1999, 2000), salt (Tanaka et al. 1999; Badawi et al. 2004; Wang et al. 2004b; Prashanth et al. 2007), drought (McKersie et al. 1996; Badawi et al. 2004; Wang et al. 2005a), oxidative stress (Bowler et al. 1991; Slooten et al. 1995; Van Camp et al. 1996; McKersie et al. 2000) and ozone induced cellular damage (Van Camp et al. 1994; Pitcher and Zilinskas 1996) in various plant species. These reports suggest SOD as a potential candidate gene to engineer plants for multiple stress tolerance.

The intracellular level of  $H_2O_2$  is regulated mainly by catalase and peroxidase enzymes (Willekens et al. 1995). A maize catalase gene (*Cat2*) was over-expressed in tobacco and it was found that transgenic plants were more tolerant to methyl viologen-induced oxidative stress (Polidoros et al. 2001). Subsequently over-expression of catalase gene from wheat (*CAT*) (Matsumura et al. 2002) and *E. coli* (*katE*) (Nagamiya et al. 2007) has been shown to confer chilling and salt stress tolerance, respectively in transgenic rice plants. In response to environmental stresses, increased activity of ascorbate peroxidase (APX) has been reported in different plant species which suggests its possible role in eliminating  $H_2O_2$  from cells. Over-expression of APX in various plant species has been done to achieve tolerance against oxidative stress (Wang et al. 1999), high temperature (Shi et al. 2001; Wang et al. 2006), low temperature (Wang et al. 2005b), drought (Yan et al. 2003) and salt (Wang et al. 2005b) stresses. Glutathione peroxidase (GPX) is the principal cellular enzyme capable of repairing membrane lipid peroxidation and is generally considered to be the main line of enzymatic defense against oxidative membrane damage (Kühn and Borchert 2002). Transgenic tobacco plants over-expressing

a cDNA encoding an enzyme with GST and GPX activity grew significantly faster than control seedlings when exposed to chilling or salt stress (Roxas et al. 1997, 2000). Transgenic tobacco plants over-expressing *Chlamydomonas* GPX-like protein in the cytosol or chloroplasts were shown to exhibit increased tolerance to oxidative stress caused by application of methyl viologen under moderate light intensity, chilling stress under high light intensity or salt stress (Yoshimura et al. 2004). Subsequently, a cDNA encoding for GPX-like protein (GPX-2) of *Synechocystis* PCC 6803 was over-expressed in *Arabidopsis* and it was shown that transgenic plants had more tolerance to the oxidative stress caused by the treatment of  $H_2O_2$ , Fe ions, methyl viologen and environmental stresses such as, chilling, high salinity, and drought (Gaber et al. 2006). Glutathione-S-transferase (GST) has been associated with detoxification of xenobiotics, limiting oxidative damage and other stress responses in plants. Over-expression of GST has been shown to confer tolerance against UV radiation (Liu and Li 2002), oxidative stress (Yu et al. 2003; Gong et al. 2005; Katsuhara et al. 2005) and salinity (Qi et al. 2004) in transgenic plants as compared to the non-transgenic plants.

It has been well established that glutathione (GSH) plays an important role in redox regulation in plants. An increase in glutathione synthesis as well as GSH/GSSG ratio has been shown to be critical for tolerance against stress conditions (Tausz et al. 2004). The glyoxalase pathway which involves glyoxalase I (*gly I*) and glyoxalase II (*gly II*) enzymes has been shown to be required for glutathione-based detoxification of a cytotoxic molecule, methylglyoxal (MG). The first evidence that over-expression of *gly I* can confer stress tolerance to the transgenic tobacco plants came through the studies from our own group (Veena et al. 1999 and Sopory, 1999). Subsequently, transgenic tobacco plants over-expressing *gly I* and *gly II* were developed and showed that transgenic plants had much higher salinity tolerance and heavy metal tolerance than non-transgenic plants (Singla-Pareek et al. 2003, 2006). Recently, over-expression of rice *gly II* gene in rice has been attempted and shown that it conferred tolerance to toxic levels of methylglyoxal and NaCl as compared with non-transgenic plants (Singla-Pareek et al. 2007).

Ascorbate is also an important antioxidant in association with other components of the antioxidant system and protects plants against oxidative damage (Smirnoff and Pallanca 1996). During the process of antioxidation, ascorbate itself is oxidized to dehydroascorbate, which is reduced to regenerate ascorbate in a reaction catalyzed by dehydroascorbate reductase (DHAR). Therefore, DHAR enzyme is assumed to be critical for ascorbate recycling. Over-expression of DHAR provided abiotic stress tolerance in transgenic tobacco (Kwon et al. 2003; Eltayeb et al. 2007) and *Arabidopsis* (Ushimaru et al. 2006) plants.

During the last decade, evidences have accumulated that alternative oxidase (AOX) is crucial in controlling the reduction state of the ubiquinone pool and helps reducing the production of ROS in the mitochondria of plant cells. The finding that tobacco culture cell mitochondria with an anti-sense construct of AOX show elevated basal ROS formation, which is further enhanced in the presence of the ETC inhibitor antimycin A, directly supported the role of AOX in alleviating ROS formation (Maxwell et al. 1999). Over-expression of AOX from *Arabidopsis* (*AtAOX1a*) (Fiorani et al. 2005; Umbach et al. 2005) and wheat (*WAOX1a*) (Sugie et al. 2006) in transgenic *Arabidopsis* plants conferred tolerance against low temperature-induced ROS production. These studies support the hypothesis that AOX alleviates oxidative stress when the cytochrome pathway of respiration is inhibited under abiotic stress conditions.

Several studies have now indicated that pyramiding of enzymes involved in antioxidant defense pathway could be a useful strategy to develop transgenic plants, which might be tolerant to multiple stresses, because of their ability to scavenge ROS efficiently. Zhao and Zhang (2006) have developed transgenic rice plants expressing glutathione S-transferase (*GST*) and catalase from *Suaeda salsa*. Transgenic plants exhibited higher tolerance against salt and oxidative stresses. In other reports, simultaneous expression of both *Cu/Zn-SOD* and *APX* in chloroplasts of potato (Tang et al. 2006) and tall fescue plants (Lee et al. 2007b) under the control of the oxidative stress-inducible promoter, sweet potato peroxidase anionic 2 (SWPA2) conferred tolerance against oxidative stress to the transgenic plants. Similarly, Lu et al. (2007)

developed transgenic *Arabidopsis* plants over-expressing two rice cytosolic APXs (*OsAPXa* and *OsAPXb*) and reported that transgenic plants exhibited increased tolerance to salt stress than wild type plants. In another recent report, simultaneous over-expression of three genes of antioxidant defense pathway viz., *Cu/Zn-SOD*, *APX* and *DHAR* in chloroplast of tobacco plants was found to exhibit very high tolerance to oxidative stress induced by paraquat and salinity stress than wild type plants (Lee et al. 2007c).

#### D Engineering Genes for Osmotic Regulation

Accumulation of osmotically active biomolecules in response to osmotic stress caused due to environmental factors such as salinity and drought is one of the major protective mechanisms, which plants have evolved to combat the stresses. Plants accumulate osmotically active compounds called osmolytes that serve as osmoprotectants and stabilize biomolecules under stress conditions. These compounds can also be referred as compatible solutes because they do not apparently interfere with the normal cellular metabolism. Over-production of various osmolytes has been tested in various plants to achieve abiotic stress tolerance.

Glycine betaine (*N,N,N*-trimethylglycine hereafter GB) which is a quaternary ammonium compound occurs naturally in a wide range of plants, animals and microorganisms (Rhodes and Hanson 1993). A major role of GB is to protect membranes and macromolecules from the damaging effects of stress. In most organisms, GB is synthesized as a result of two-step oxidation of choline via betaine aldehyde, a toxic intermediate. In higher plants, GB biosynthetic pathway involves choline monoxygenase (CMO) and betaine aldehyde dehydrogenase (BADH) enzymes (Weigel et al. 1986; Brouquisse et al. 1989). Whereas, in mammalian cells and microorganisms such as *E. coli*, GB is synthesized by choline dehydrogenase (CDH) in combination with BADH (Wilken et al. 1970; Landfald and Strom 1986). In contrast to each of these two pathways that involved two enzymes, the biosynthesis of GB is catalysed by a single enzyme choline oxidase (COD) in certain microorganisms such as the soil bacterium *Arthrobacter globiformis*



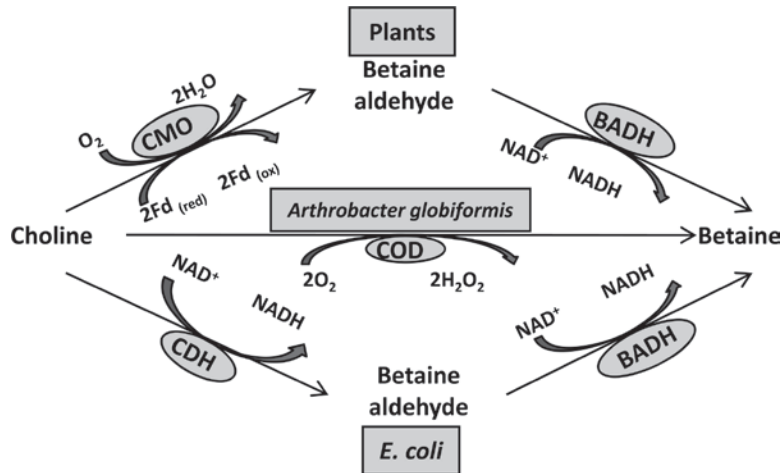

Fig. 4. Glycine betaine biosynthetic pathways in plants, *E. coli* and *Arthrobacter globiformis*. In plants and *E. coli*, betaine is synthesized from choline in a two step pathway. These steps are catalyzed by CMO and BADH enzymes in plants, while, by CDH and BADH in *E. coli*. In *Arthrobacter globiformis* betaine is synthesized via a single step reaction catalyzed by COD enzyme. Genes coding for each of the four enzymes have been over-expressed in plants to manipulate abiotic stress tolerance, however, *codA*, which code for COD enzyme has most widely been used for raising abiotic stress tolerant transgenic plants.

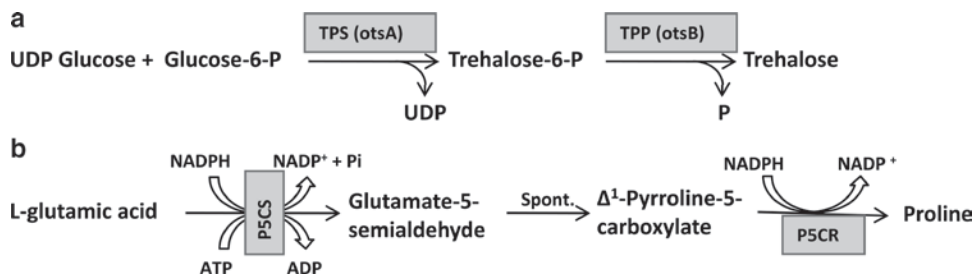

Fig. 5. (a) Biosynthetic pathway of trehalose. Trehalose is synthesized from UDP glucose and Glucose-6-P in a two step pathway catalyzed by TPS (otsA) and TPP (otsB) enzymes, (b) Biosynthetic pathway of proline. Proline is synthesized from L-glutamic acid in a three step pathway. P5CS is the rate limiting enzyme of this pathway and gene coding for this enzyme has been over-expressed in plants to develop abiotic stress tolerant transgenic plants.

(Ikuta et al. 1977) (Fig. 4). To achieve tolerance against various abiotic stresses, over-expression of *CMO* (Shirasawa et al. 2006), *BADH* (Moghaieb et al. 2000; Kumar et al. 2004; Yang et al. 2005), *CDH* (Lilius et al. 1996; Quan et al. 2004) has been carried out in several plant species. Over-expression of *codA* gene encoding COD has been most widely attempted to develop abiotic stress tolerant transgenic plants, including *Arabidopsis* (Hayashi et al. 1997; Alia et al. 1998a,b; Huang et al. 2000; Sakamoto et al. 2000; Sulpice et al. 2003), *Brassica* (Huang et al. 2000; Prasad and Pardha-Saradhi 2004), rice (Sakamoto et al. 1998; Mohanty et al. 2002; Su et al. 2006) tobacco (Huang et al. 2000; He et al. 2001; Parvanova

et al. 2004), and tomato (Park et al. 2004). However, recently it has been reported that GB accumulation is more effective in chloroplasts than in cytosol for protecting transgenic tomato plants against abiotic stresses (Park et al. 2007).

In organisms ranging from bacteria to higher plants, there is a strong correlation between increased cellular proline levels and the capacity to survive osmotic stress due to water deficit and high salinity. Proline is synthesized from glutamate via two intermediates- glutamic- $\gamma$ -semialdehyde and  $\Delta^1$ -pyrroline-5-carboxylate. The first step is catalyzed by  $\Delta^1$ -pyrroline-5-carboxylate synthetase (P5CS), and is rate limiting (Delauney and Verma 1993) (Fig. 5a). Over-expression of

*P5CS* has been reported in tobacco (Kavi Kishor et al. 1995; Parvanova et al. 2004), potato (Hamida-Sayari et al. 2005), petunia (Yamada et al. 2005), citrus (Molinari et al. 2004), sugarcane (Molinari et al. 2007), wheat (Sawahel and Hassan 2002) and rice (Zhu et al. 1998; Su and Wu 2004) plants. These transgenic plants were shown to exhibit improved performance under various abiotic stresses.

Trehalose, a non-reducing disaccharide of glucose plays an important role as an abiotic stress protectant in a large number of organisms, including bacteria, yeast and invertebrates. Trehalose stabilizes dehydrated enzymes, proteins and lipid membranes and protects biological structures from damage during desiccation. Most plant species accumulate only a low level of trehalose, with the exception of highly desiccation-tolerant resurrection plant, *Selaginella lepidophylla* (Wingler et al., 2002). In bacteria and yeast, trehalose is synthesized in a two-step reaction: trehalose-6-phosphate is first formed from UDP-glucose and glucose-6-phosphate in a reaction catalyzed by trehalose-6-phosphate synthase (TPS). Trehalose-6-phosphate is then converted to trehalose by trehalose-6-phosphate phosphatase (TPP) (Goddijn and van Dun 1999) (Fig. 5b). Goddijn et al. (1997) have engineered trehalose biosynthesis in tobacco and potato by introducing *otsA* and *otsB* genes from *E. coli* and found that transgenic plants accumulate very low amounts of trehalose in their leaves. This was attributed to high activity of trehalase, an enzyme, which hydrolyzes trehalose to two molecules of glucose. Accumulation of trehalose by introducing yeast *TPS1* gene in transgenic potato plants leads to drought tolerance (Yeo et al. 2000). The first successful report where engineering of trehalose biosynthesis was shown to confer salinity and drought stress tolerance in crop plant rice came from the studies by Garg et al. (2002). They have expressed *E. coli* trehalose biosynthesis genes *otsA* and *otsB* as a fusion gene under the control of either tissue-specific or stress-dependent promoters and found that several independent transgenic lines exhibited sustained plant growth, less photo-oxidative damage, and more favorable mineral balance under salt, drought, and low temperature stress conditions. In a similar report *otsA* and *otsB* genes were expressed as fusion gene in rice under the control of maize

ubiquitin promoter and shown that transgenic plants exhibited drought and salinity stress tolerance (Jang et al. 2003). Recently, yeast *TPS* and *TPP* genes were expressed in *Arabidopsis* plants either under the control of *Arabidopsis* RuBisCO promoter (AtRbcS1A) giving constitutive production or under the control of drought-inducible *Arabidopsis* AtRAB18 promoter or under the control of AtRbcS1A promoter together with a chloroplastic transit peptide in front of the coding sequence of *ScTPS1* and showed that all three strategies resulted in transgenic plants with increased drought tolerance without growth aberrations, suggesting that growth aberrations and improved drought tolerance can be uncoupled (Karim et al. 2007).

Polyamines (PAs) are low-molecular weight polycations which function as one of the most important nitrogenous osmolytes during osmotic stress. The key enzymes in polyamine biosynthesis are arginine decarboxylase (ADC), ornithine decarboxylase (ODC) and S-adenosylmethionine decarboxylase (SAMDC) (Fig. 6). Over-production of polyamines was achieved by the over-expression of *ADC* (Capell et al. 1998, 2004; Roy and Wu 2001), *ODC* (Minocha and Sun 1997) and *SAMDC* (Roy and Wu 2002; Waie and Rajam 2003) in different plant species and it was shown that transgenic plants had higher abiotic stress tolerance as compared to non-transgenic plants. Over-expression of spermidine synthase from *Cucurbita ficifolia* in *Arabidopsis* leads to enhanced tolerance to various stresses including chilling, freezing, salinity, hyperosmosis, drought and paraquat toxicity (Kasukabe et al. 2004). In the polyamine biosynthesis pathway there is a metabolic competition for S-adenosylmethionine as a precursor between polyamine and ethylene biosynthesis. Antisense-expression of cDNAs for senescence-related 1-aminocyclopropane-1-carboxylic acid (ACC) synthase (*CAS*) and ACC oxidase (*CAO*), isolated from carnation was carried out in transgenic tobacco plants, which exhibited tolerance against oxidative stress, high salinity, acid stress (pH 3.0) and ABA treatment (Wi and Park 2002).

Osmotin and osmotin-like proteins have been shown to be associated with osmotic stress and plant pathogen defense. A genomic clone that contains two genes encoding osmotin-like proteins (*OSML13* and *OSML81*) and arranged in

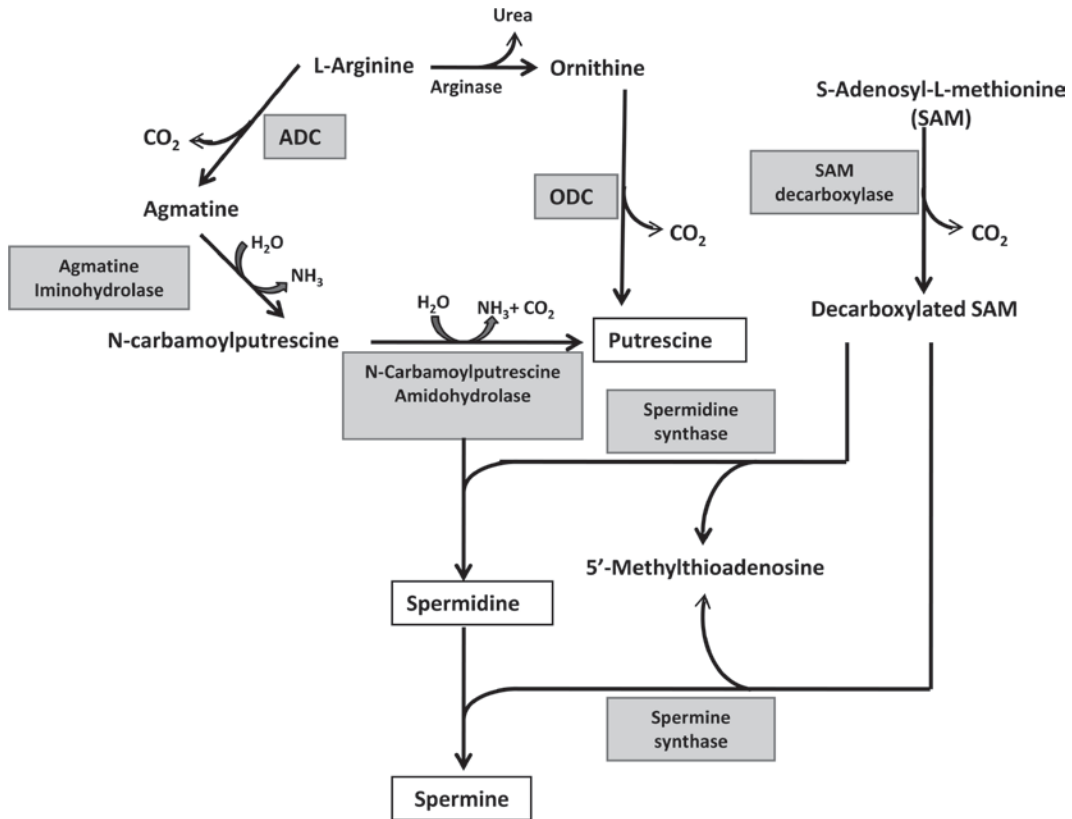

Fig. 6. Biosynthetic pathway of polyamines viz. putrescine, spermidine and spermine. In most plants, ADC is more active than ODC. Genes coding for the enzymes, which have been marked in oval have been overexpressed in plants to develop abiotic stress tolerant transgenic plants.

the same transcriptional orientation has been isolated from potato. These genes were shown to be induced by ABA, NaCl, salicylic acid, wounding and fungal infection (Zhu et al. 1995). Transgenic potato plants constitutively overexpressing *pA13*, encoding for an osmotin-like protein showed an increased tolerance to the late blight fungus *Phytophthora infestans*, but does not give freezing tolerance (Zhu et al. 1996). However, Barthakur et al. (2001) have shown that over-expression of osmotin in transgenic tobacco induces accumulation of proline and confers osmotic stress tolerance. Constitutive over-expression of osmotin in olive tree conferred tolerance against cold stress by affecting programmed cell death and cytoskeleton organization (D'Angeli and Altamura 2007).

The accumulation of polyols, either straight chain metabolites such as mannitol and sorbitol

or cyclic polyols such as *myo*-inositol and its methylated derivatives such as ononitol and pinitol is correlated with salinity and drought tolerance in many lower and higher plants and animals (Bohnert and Jensen 1996). Polyols act as osmolytes by facilitating the retention of water and allowing sequestration of sodium to the vacuole or apoplast. They might also protect cellular structures by scavenging active oxygen through their interaction with membranes, protein complexes or enzymes (Bohnert et al. 1995).

The *E. coli* gene, *mtlD* coding for mannitol-phosphate-dehydrogenase was engineered for expression in higher plants. Over-expression of *mtlD* gene in tobacco plants resulted in accumulation of mannitol in cytoplasm, which conferred high salinity and drought tolerance in transgenic plants (Tarczynski et al. 1992, 1993; Karakas et al. 1997). Moreover, targeting *mtlD*

gene in chloroplasts of transgenic tobacco plants resulted in increased resistance to methyl viologen-induced oxidative stress (Shen et al. 1997). *Arabidopsis* plants over-expressing *mtlD* gene, accumulated mannitol, when *MtlD*-expressing seeds and control seeds were imbibed with solutions containing NaCl (range 0–400 mM), transgenic seeds containing mannitol germinated in medium supplemented with up to 400 mM NaCl, whereas control seeds ceased germination at 100 mM NaCl (Thomas et al. 1995). Subsequently, *mtlD* has been expressed in eggplant (Prabhavathi et al. 2002), wheat (Abebe et al. 2003), petunia (Chiang et al. 2005), loblolly pine (Tang et al. 2005) and *Populus* (Hu et al. 2005), and the transgenic plants accumulated mannitol and conferred tolerance against various abiotic stresses. Mannitol is also synthesized via the action of mannose-6-phosphate reductase (M6PR) in salt tolerant plant species celery (*Apium graveolens* L.). Over-expression of celery *M6PR* in *Arabidopsis* resulted in accumulation of mannitol in transgenic plants. In the presence of NaCl, transgenic plants showed a high level of salt tolerance, i.e. growing, completing normal development, flowering, and producing seeds in soil irrigated with 300 mM NaCl in the nutrient solution (Zhifang and Loescher 2003), and also protects photosynthesis against salt-related damage to chloroplasts (Sickler et al. 2007). Thus, mannitol accumulation in transgenic plants enhances tolerance to high salt and water deficit stress primarily through osmotic adjustment and also improves tolerance to stress through scavenging of hydroxyl radicals and stabilization of macromolecular structures.

L-*myo*-inositol and its derivatives are commonly associated with cell signaling and membrane biogenesis, but they also participate in stress responses in plants and animals, particularly to salt stress (Nelson et al. 1998). The primary enzyme for the synthesis of L-*myo*-inositol 1-phosphate from glucose 6-phosphate is L-*myo*-inositol-1-phosphate synthase (MIPS) through an internal oxidation-reduction reaction. A *PINO1* gene encoding the MIPS protein was cloned from the wild halophytic rice *Porteresia coarctata* and characterized (Majee et al. 2004). Introgression of *PINO1* in transgenic tobacco led to increased inositol production compared with unstressed control and transgenic plants were able to grow in 200–300 mM NaCl conditions with retention

of ~40–80% of the photosynthetic competence. Moreover, introgression of the same *PcINO1* gene has been shown to confer salt tolerance to the evolutionary divergent organisms, including unicellular prokaryote, *E. coli*, unicellular non-photosynthetic eukaryote, *Schizosaccharomyces pombe*, a monocot crop, rice (*Oryza sativa*) and a dicot crop mustard (*Brassica juncea*) (Das-Chatterjee et al. 2006). In some salt tolerant plant species, inositol provides the substrate for the production of the cyclic sugar alcohols, pinitol and D-ononitol, which accumulate and help to lower the cytoplasmic osmotic potential and to balance sodium accumulation in the vacuole. Tobacco plants transformed with *IMT1*, encoding *myo*-inositol-O-methyl transferase resulted in accumulation of D-ononitol and could tolerate salt as well as drought stress much better than the control plants (Sheveleva et al. 1997). In another study, Sheveleva et al. (2000) developed a cross between transgenic tobacco expressing *mtlD* in chloroplasts and *IMT1* in cytosol, which led to the expression of two genes, *mtlD* and *IMT1*. Plants expressing both the genes accumulated mannitol and D-ononitol in amounts comparable to those following the single gene transfers and showed phenotypically normal growth during the vegetative stage.

Ectoine (1,4,5,6-tetrahydro-2-methyl-4-pyrimidine carboxylic acid) was identified as a compatible solute in *Ectothiorhodospira halochloris*, an extremely halophilic phototrophic eubacterium (Galinski et al. 1985). The usefulness of ectoine as an enzyme protectant against heat, freezing, and drying has been demonstrated (Lippert and Galinski 1992). The biosynthetic pathway of ectoine comprises of three steps enzymatic reactions involving *ectA*, *ectB* and *ectC* genes encoding L-2,4-diaminobutyric acid acetyltransferase, L-2,4-diaminobutyric acid transaminase and L-ectoine synthase, respectively. To investigate the function of ectoine as a compatible solute in plant cells, the three genes were individually placed under the control of CaMV35S promoter and introduced together in cultured tobacco cells. The transgenic cells accumulated small quantity of ectoine and showed increased tolerance to hyperosmotic shock (900 mOsm) (Nakayama et al. 2000). The transgenic cells also showed normal growth pattern under hyperosmotic conditions in which growth of the untransformed cells



was delayed indicating that ectoine accumulation results in hyperosmotic tolerance. Recently, ectoine biosynthetic genes (ect. A,B,C) from *Halomonas elongata* were introduced into the tobacco plant and it was found that ectoine accumulation in transgenic plants improved salt tolerance in two ways. First, ectoine improved root function, which enabled roots to take up water consistently and supply to shoots under saline conditions. Second, ectoine enhanced nitrogen supply to leaves by increasing transpiration and by protecting Rubisco proteins from deleterious effects of salt, thereby improving the rate of photosynthesis (Moghaieb et al. 2006).

### *E Engineering Genes for Cellular Protection*

Antifreeze proteins (AFPs) bring about lowering of freezing point by inhibiting binding of additional water molecules to ice crystals. When an antifreeze gene analogue was expressed in yeast, enhanced survival after freezing was observed (McKown and Warren 1991). A carrot AFP gene coding for leucine-rich-repeat protein was over-expressed in tobacco and shown that AFP protein accumulated in apoplast and inhibited ice recrystallization (Worrall et al. 1998). Meyer et al. (1999) have also shown that when carrot AFP gene was over-expressed in *Arabidopsis*, AFP gets accumulated in apoplast and modifies ice crystal morphology. However, a type II fish AFP gene over-expression in transgenic tobacco was shown to inhibit ice recrystallization, but had no effect on frost resistance as compared to non-transgenic plants (Kenward et al. 1999). A synthetic gene based on the primary sequence of the mature budworm AFP (*sbwAFP*) was over-expressed in transgenic tobacco plants and AFP protein accumulation inhibited ice recrystallization and increased thermal hysteresis (Holmberg et al. 2001). Tomczak et al. (2002) have reported that during chilling to nonfreezing temperatures, the alpha-helical AFP type I from polar fish inhibits electrolyte leakage across model membranes containing an unsaturated chloroplast galactolipid. The mechanism involves binding of the AFP to the lipid bilayer, which increases the phase transition temperature of the membranes and alters the molecular packing of the acyl chains, which might result in the reduced membrane permeability.

An insect AFP gene was over-expressed in *Arabidopsis*, but transgenic plants did not demonstrate improved ability to survive freezing when compared to the wild type. However, when cooled under four different regimes, transgenic plants froze at significantly lower temperatures than wild type (Huang et al. 2002). Recently, a codon optimized AFP gene was expressed in the transgenic wheat plants with apoplast targeted signal peptide and the transgenic plants exhibited high levels of antifreeze activity and significant freezing protection at temperatures as low as  $-7^{\circ}\text{C}$  (Khanna and Daggard 2006).

Late embryogenesis abundant (LEA) proteins have been implicated in many stress responses in plants. LEA proteins are ubiquitously present in plants, which get accumulated during the late stage of seed formation and in vegetative tissues under drought, heat, cold, and salt stress conditions or with abscisic acid (ABA) application (Sivamani et al. 2000). LEA proteins are associated with tolerance to water stress resulting from desiccation and cold shock. Recently, LEA proteins have been shown to act as molecular chaperons or space fillers to prevent cellular collapse at low water potential. This capacity of LEA proteins is probably attributable in part to their structural plasticity, as they are largely lacking in secondary structure in the fully hydrated state, but can become more folded during water stress and/or through association with membrane surfaces (Goyal et al. 2005; Tunnacliffe and Wise 2007). Pathways leading to the activation of LEA-type genes including the dehydration responsive element (DRE)/C-repeat (CRT) class of stress-responsive genes may be different from the pathways regulating osmolyte production. The activation of LEA-type genes may actually represent damage repair pathways (Xiong and Zhu 2002). LEA proteins were first characterized in cotton (Dure and Galau 1981; Dure and Chlan 1981). Subsequently, many LEA proteins and their genes have been characterized from different plant species (Dure 1992). The *HVA1* gene was first isolated from the aleurone layers of barley seeds as an ABA-inducible gene (Hong et al. 1988). Since then, diverse plant species have been transformed with barley *HVA1* and transgenic plants were shown to confer tolerance against water deficiency and salt stress in *japonica* rice cv Nipponbare (Xu et al. 1996; Babu et al. 2004), *indica* rice cv Pusa Basmati 1

(Rohila et al. 2002), wheat (Sivamani et al. 2000), oat (Oraby, et al. 2005), creeping bentgrass (Fu et al. 2007), and mulberry (Lal et al. 2007). Moreover, several other LEA protein genes have also been reported to augment abiotic stress tolerance in a range of plant species. Wheat *LEA* genes, PMA80 and PMA1959 have also been shown to confer dehydration tolerance in transgenic rice (Cheng et al. 2002). A group 3 *LEA* gene from *Brassica napus* has been reported to confer water deficit and salt tolerance in transgenic radish (*Raphanus sativus* L.) (Park et al. 2005a). A cold-responsive (Cor) *LEA* gene from wheat (*WCOR15*) has been shown to contribute positively to the development of freezing tolerance in the transgenic tobacco plants (Shimamura et al. 2006). Recently, it has been shown that group 2 *LEA* gene, *Rab16a* from the *indica* rice Pokkali when over-expressed in tobacco confer salinity tolerance (RoyChoudhury et al. 2007). In another recent report, a rice *LEA* protein gene *OsLEA3-1* was identified and its promoter was isolated from upland rice *IRAT109*, which exhibits strong activity under drought and salt stress conditions. Three expression plasmids consisting of full-length cDNA driven by the *OsLEA3-1* (*OsLEA3-H*), the CaMV35S promoter (*OsLEA3-S*), and the rice Actin1 promoter (*OsLEA3-A*) were transformed into the drought-sensitive *japonica* rice cv Zhonghua 11. Transgenic rice plants, developed by the transformation with *OsLEA3-H* and *OsLEA3-S* constructs had higher grain yield than the wild type under drought stress in field conditions (Xiao et al. 2007). Analyses of two barley genes, *HVA1* and *HVA22*, indicate that their response to ABA relies on the interaction of two *cis*-acting elements in their promoters, viz an ABA response element (ABRE) and a coupling element (CE). Together, they form an ABA response promoter complex (ABRC). Comparison of promoters of barley *HVA1* and its rice orthologue indicates that the structure and sequence of their ABRCs are highly similar (Ross and Shen 2006). These studies clearly show the ability of *LEA* genes to confer water deficiency tolerance in plants. Moreover, their promoters could also be used to regulate the drought-inducible expression of transgenes in transgenic technology.

Another group of *LEA* proteins is dehydrins (DHNs), which are group II *LEA* proteins. DHNs are highly hydrophilic and thermostable and are

proposed to act as structure stabilizers and have detergent and chaperone like properties. DHNs are localized in the different cell compartments, such as nucleus, cytoplasm, mitochondria, vacuole and plasma membrane (Borovskii et al. 2002; Rorat 2006). Spinach genes *CAP160* and *CAP85* (Kaye et al. 1998) and citrus dehydrin gene (Hara et al. 2003), members of the *LEA*/dehydrin superfamily, were introduced into tobacco and plants expressing the proteins were evaluated for freezing-stress tolerance and found that transgenic plants had lower levels of electrolyte leakage than wild type plants. To elucidate the contribution of DHNs to freezing stress tolerance in *Arabidopsis*, transgenic plants over-expressing multiple *DHN* genes were generated. Double gene plasmids for expression of *RAB18* and *COR47* (pTP9) or *LTI29* and *LTI30* (pTP10) were made and over-expression of chimeric genes in *Arabidopsis* resulted in accumulation of the corresponding dehydrins to levels similar or higher than in cold-acclimated wild-type plants. Transgenic plants showed improved survival when exposed to freezing stress compared to the control plants (Puhakainen et al. 2004). Recently, a wheat *DHN5* gene, which is induced by salt and ABA was over-expressed in *Arabidopsis* and found that transgenic plants exhibited stronger growth under high concentration of NaCl or water deprivation, and showed a faster recovery after mannitol treatment (Brini et al. 2007a). These studies suggest that dehydrin facilitates plant cold acclimation by acting as a radical scavenging protein to protect membrane systems under cold stress.

### F Engineering Genes for Ionic Balance

Under salinity stress, another strategy for achieving greater tolerance is to help plants re-establish ionic balance. It is important to prevent Na<sup>+</sup> accumulation to a high level in the cytoplasm or in organelles other than the vacuole, since excess Na<sup>+</sup> inhibits many cellular activities (Zhu 2001). It has been reported that in salt-tolerant plants, the compartmentalization of Na<sup>+</sup> into vacuoles through the operation of a vacuolar Na<sup>+</sup>/H<sup>+</sup> antiporter provides an efficient mechanism to prevent the deleterious effects of Na<sup>+</sup> accumulated in the vacuole to drive water into the cells (Glenn et al. 1999). It has been reported that endogenous levels of Na<sup>+</sup>/H<sup>+</sup> antiporter remain low in salt sensitive

plants such as rice even when subjected to salt stress (Fukuda et al. 1998). The *Arabidopsis thaliana* genome-sequencing project has allowed the identification of a plant gene (*AtNHX1*) homologous to the *Saccharomyces cerevisiae* *Nhx1* and its over-expression in *Arabidopsis* promotes sustained growth and development in soil watered with up to 200 mM sodium chloride (Apse et al. 1999). Subsequently, over-expression of *AtNHX1* has been shown to confer enhanced salt tolerance in tomato (Zhang and Blumwald 2001), *Brassica* (Zhang et al. 2001), wheat (Xue et al. 2004), maize (Xiao-Yan et al. 2004) and cotton (He et al. 2005). Over-expression of *Atriplex gmelini* *NHX* (*AgNHX1*) (Ohta et al. 2002), rice *NHX* (*OsNHX1*) (Fukuda et al. 2004), *Suaeda salsa* *NHX* (*SsNHX1*) (Zhao et al. 2006a), and *Pennisetum glaucum* *NHX* (*PgNHX1*) (Verma et al. 2007) in rice; *Gossypium hirsutum* *NHX* (*GhNHX1*) (Wu et al. 2004) and *Glycine max* *NHX* (*GmNHX1*) (Li et al. 2006) in tobacco; *Pennisetum glaucum* *NHX* (*PgNHX1*) in *Brassica* (Rajagopal et al. 2007), *Triticum aestivum* *NHX* (*TaNHX1*) in *Arabidopsis* (Brini et al. 2007b) have been attempted and found that transgenic plants exhibited higher salt tolerance than non-transgenic plants. Beside *NHX*, over-expression of a plasma membrane  $\text{Na}^+/\text{H}^+$  antiporter *SOD2* from yeast (*Schizosaccharomyces pombe*) increased salt tolerance in transgenic rice (Zhao et al. 2006b).

An alternative strategy to generate salt tolerant plants is the introduction of halotolerance genes involved in the regulation of ion homeostasis such as *HAL1*, *HAL2* and *HAL3* from yeast. Over-expression of *HAL1* in melon (Bordas et al. 1997), tomato (Gisbert et al. 2000; Zhang et al. 2001a), *Arabidopsis* (Yang et al. 2001) and watermelon (Ellul et al. 2003) has been shown to confer salt tolerance in transgenic plants. In addition, measurement of the intracellular  $\text{K}^+$  to  $\text{Na}^+$  ratios showed that transgenic plants were able to retain more  $\text{K}^+$  and less  $\text{Na}^+$  than the control plants under salt stress. Similarly, over-expression of *HAL2* gene in tomato improved the root development on  $\text{NaCl}$ -supplemented medium (Arrillaga et al. 1998).

During salt and drought stress, plants tend to maintain their turgor pressure at low water potentials by increasing the number of solute molecules in the cell. A vacuolar  $\text{H}^+$ -pyrophosphatase

encoded by a single gene (*AVP1*) was identified from *Arabidopsis*. Heterologous expression of this plant *AVP1* in yeast restored salt tolerance to a salt sensitive mutant (Gaxiola et al. 1999). Transgenic *Arabidopsis* plants, over-expressing *AVP1*, were more tolerant to high concentrations of  $\text{NaCl}$  and to water deprivation as compared to the wild type plants. These tolerant phenotypes were associated with increased internal stores of solutes (Gaxiola et al. 2001). *AVP1* has also been shown to control auxin transport and consequently auxin-dependent development. *AVP1* over-expression in transgenic *Arabidopsis* plants resulted in increased cell division at the onset of organ formation, hyperplasia and increased auxin transport (Li et al. 2005). Over-expression of *AVP1* in tomato resulted in: (a) greater pyrophosphatase-driven cation transport into root vacuolar fractions, (b) increased root biomass and (c) enhanced recovery of plants from imposed soil water deficit stress. More robust root systems allowed transgenic plants to take up more water during water deficit stress (Park et al. 2005b). Recently,  $\text{H}^+$ -pyrophosphatase gene from *Thellungiella halophila* (*TsVP*) has been identified and its over-expression in tobacco has been shown to accumulate 25% more solutes than the wild type plants without  $\text{NaCl}$  stress and 20–32% more  $\text{Na}^+$  under salt stress conditions. Although transgenic tobacco lines accumulated more  $\text{Na}^+$  in leaf tissues, the malondialdehyde content and cell membrane damage were less than those of the wild type under salt stress conditions. Presumably, compartmentalization of  $\text{Na}^+$  in vacuoles reduces its toxic effects on plant cells (Gao et al. 2006a). These results support the hypothesis that over-expression of vacuolar  $\text{H}^+$ -PPase causes the accumulation of  $\text{Na}^+$  in vacuoles, instead of in the cytoplasm and avoids the toxicity of excessive  $\text{Na}^+$  in plant cells.

A high affinity potassium transporter gene *HKT1* was isolated from wheat roots and initial heterologous expression studies in yeast suggested that it mediates  $\text{H}^+$ -coupled high affinity  $\text{K}^+$  uptake (Schachtman and Schroeder 1994). However, subsequent studies showed that *HKT1*-mediated  $\text{K}^+$  transport was energized through coupling to  $\text{Na}^+$  rather than  $\text{H}^+$  (Rubio et al. 1995; Gassman et al. 1996). A potential role of *HKT1* in  $\text{Na}^+$ , rather than  $\text{K}^+$  transport, was further substantiated by work on the *Arabidopsis* *HKT1*

orthologue expressed in oocyte (Uozumi et al. 2000), which showed that *AtHKT1* selectively transport  $\text{Na}^+$  but not  $\text{K}^+$ . Berthomieu et al. (2003) have isolated two allelic mutants of *Arabidopsis* displaying sodium over-accumulation in shoots, *sas2-1* and *sas2-2*, and identified their corresponding gene, *AtHKT1*. Functional analyses indicated that the *AtHKT1* is involved in  $\text{Na}^+$  recirculation from shoots to roots and that this process plays a crucial role in plant tolerance to salinity. Further, Sunarpi et al. (2005) showed that *AtHKT1* is targeted to the plasma membrane in xylem parenchyma cells of leaves. *AtHKT1* disruption alleles caused large increases in the  $\text{Na}^+$  content of the xylem sap and conversely reduced the  $\text{Na}^+$  content of the phloem sap. The *athkt1* mutant alleles had a smaller and inverse influence on the  $\text{K}^+$  content compared with the  $\text{Na}^+$  content of the xylem, suggesting that  $\text{K}^+$  transport may be indirectly affected. These findings show that *AtHKT1* selectively unloads  $\text{Na}^+$  directly from xylem vessels to xylem parenchyma cells. *AtHKT1* mediates osmolality balance between xylem vessels and xylem parenchyma cells under saline conditions. Thus, *AtHKT1* reduces the sodium content in xylem vessels and leaves, thereby playing a central role in protecting plant leaves from salinity stress. A rice homolog of shaker family  $\text{K}^+$  channel *KAT1* (*OsKAT1*) has been identified from full-length cDNA expression library of *japonica* rice cv. Nipponbare. *OsKAT1* was shown to suppress the salt-sensitive phenotype of yeast mutant, which lacks a major component of  $\text{Na}^+$  efflux. Over-expression of *OsKAT1* in rice conferred salt stress tolerance in transgenic rice (Obata et al. 2007).

Aquaporins are water channel proteins of intracellular membranes and plasma membranes that play a crucial role in plant water relations. Since several abiotic stresses such as, drought, salinity and freezing, manifest themselves via altering water status of plant cells and are linked by the fact that they all result in cellular dehydration, the role of aquaporins during abiotic stress conditions seems to be crucial. To elucidate the significance of aquaporins in the physiology of water transport in multicellular organisms, a tobacco plasma membrane aquaporin *NtAQPI* was expressed in anti-sense orientation and transgenic plants were compared with the wild type plants. It was shown that plants impaired in *NtAQPI*

expression showed reduced root hydraulic conductivity and lower water stress tolerance, which suggested the importance of symplastic aquaporin-mediated water transport in whole-plant water relations (Siefritz et al. 2002). The extent to which aquaporins contribute to plant water status under favorable growth conditions and abiotic stress was determined by Aharon et al. (2003). They constitutively over-expressed the *Arabidopsis* plasma membrane aquaporin, PIP1b in transgenic tobacco plants and showed that under favorable growth conditions, its over-expression significantly increased plant growth rate, transpiration rate, stomatal density and photosynthetic efficiency. Contrastingly, PIP1b over-expression had no beneficial effect under salt stress, whereas during drought stress it had a negative effect, causing faster wilting. This suggested that aquaporins might not have any beneficial effect under salt stress, and may in fact be deleterious during drought stress. Similarly, transgenic rice plants over-expressing barley *HvPIP2;1* exhibited increased radial hydraulic conductivity of roots as well as increased mass ratio of shoots to root, whereas under salt stress conditions growth reduction was greater in transgenic plants than in non-transgenic plants (Katsuhara et al. 2003). However, Lian et al. (2004) observed that upland rice and lowland rice had different expression pattern for aquaporin *RWC3* during water deficit at both mRNA and protein levels. To further understand the role of *RWC3* in drought tolerance in rice, *RWC3* was over-expressed in lowland rice, under the control of a stress-inducible SWPA2 promoter. The lowland rice plants over-expressing *RWC3* had better water status under water deficit conditions suggesting that *RWC3* probably adjusted the water movement across plasma membrane during water deficit for drought avoidance. In another study, transgenic *Arabidopsis* plants over-expressing an aquaporin from *Panax ginseng*, *PgTIP1* were shown to possess increased plant growth as determined by the biomass production, and leaf and root morphology under favorable growth conditions. Moreover, under salt stress conditions transgenic plants exhibited superior growth and seed germination. Transgenic plants were more tolerant to water stress but, their cold acclimation ability was lower than non-transgenic plants (Peng et al. 2007). Recently, transgenic *Arabidopsis* and



tobacco plants, constitutively over-expressing *Arabidopsis PIP1;4* or *PIP2;5* were developed and it was found that there were no significant differences in growth rates and water transport between transgenic and non-transgenic plants, when grown under favorable growth conditions. In contrast, the transgenic plants displayed a rapid water loss under dehydration stress, which resulted in retarded germination and seedling growth under drought stress, whereas under cold stress transgenic plants exhibited enhanced water flow and improved germination (Jang et al. 2007). These studies demonstrated various physiological functions of aquaporins under favorable and stress conditions. The challenge in the coming years will be to integrate this knowledge in the plants to make them stress tolerant.

Calcium exchanger 1 (CAX1) was the first plant gene encoding a  $\text{Ca}^{2+}/\text{H}^{+}$  antiporter to be cloned. It was identified by screening a cDNA library from *Arabidopsis* for clones able to complement a yeast mutant defective in vacuolar  $\text{Ca}^{2+}$  transport (Hirschi et al. 1996). Transgenic tobacco plants over-expressing *CAX1* displayed symptoms of  $\text{Ca}^{2+}$  deficiency, including hypersensitivity to ion imbalance, such as increased magnesium and potassium concentrations, and to cold shock (Hirschi 1999). Catalá et al. (2003) have identified two T-DNA insertion mutants, *cax1-3* and *cax1-4*, that display reduced tonoplast  $\text{Ca}^{+}/\text{H}^{+}$  antiport activity. The mutants showed no significant differences with respect to the wild type when analyzed for dehydration, high salt, chilling or constitutive freezing tolerance. However, they exhibited increased freezing tolerance after cold acclimation, demonstrating that CAX1 plays an important role in this adaptive response. This phenotype correlates with the enhanced expression of *CBF/DREB1* genes and their corresponding targets in response to low temperature. This showed that CAX1 ensures the development of cold acclimation response in *Arabidopsis* by controlling the induction of CBF/DREB1 and downstream genes. A soybean CAX1 (*GmCAX1*) expresses in all tissues of the soybean plant, when it was over-expressed in *Arabidopsis* transgenic plants accumulated less  $\text{Na}^{+}$ ,  $\text{K}^{+}$  and  $\text{Li}^{+}$  and were more tolerant to elevated  $\text{Li}^{+}$  and  $\text{Na}^{+}$  levels during germination when compared with the controls. These data suggested that CAX1 might be beneficial for regulation of ion homeostasis and thus confer salt tolerance (Luo et al. 2005).

### III Future Perspectives

It is clear that scientists have had a great deal of interest in understanding the mechanism of abiotic stress and producing transgenic plants with improved abiotic stress tolerance. Even though extensive amounts of knowledge have accumulated during the last 10 years, the fact that these transgenic plants with improved performance towards abiotic stresses are yet to reach the farmer's field is still baffling plant scientists. Is it that we still need to identify and validate 'better' candidate genes that can significantly improve the tolerance as well as yield of the transgenic plant under stress conditions? Under field conditions, plants can be exposed to multiple stresses simultaneously, thus identification of those genes which could confer multiple stress tolerance becomes more important. Since abiotic stress tolerance of plants is a complex trait and involves multiple physiological and biochemical mechanisms, future work for improvement of plant stress tolerance should involve pyramiding of multiple genes. This can be done either by combining genes involved in single protective pathway or by combining genes involved in diverse protective pathways. Furthermore, development of strong stress regulated promoters to direct the expression of the transgene would be of additional importance and benefit. Continued efforts addressing the above mentioned challenges are needed to reach the final goal of generating transgenic plants, especially crop plants that are highly tolerant to different abiotic stresses.

### Acknowledgements

The work in the laboratory of SKS and SLS-P is supported by grants from ICGEB and Department of Biotechnology, Department of Science and Technology, Government of India. We thank Prof. R.C. Pant for critically reading this manuscript. We apologize to all colleagues whose work could not be cited due to space restriction.

### References

- Abbasi F, Onodera H, Toki S, Tanaka H, Komatsu S (2004) OsCDPK13, a calcium-dependent protein kinase gene from rice, is induced by cold and gibberellin in rice leaf sheath. *Plant Mol Biol* 55:541–552

- Abe H, Yamaguchi-Shinozaki K, Urao T, Lwasaki T, Hosokawa D, Shinozaki K (1997) Role of *Arabidopsis* MYC and MYB homologs in drought- and abscisic acid-regulated gene expression. *Plant Cell* 9:1859–1868
- Abe H, Urao T, Ito T, Seki M, Shinozaki K, Yamaguchi-Shinozaki K (2003) *Arabidopsis* AtMYC2 (bHLH) and AtMYB2 (MYB) function as transcriptional activators in abscisic acid signaling. *Plant Cell* 15:63–78
- Abebe T, Guenzi AC, Martin B, Cushman JC (2003) Tolerance of mannitol-accumulating transgenic wheat to water stress and salinity. *Plant Physiol* 131:1748–1755
- Agarwal PK, Agarwal P, Reddy MK, Sopory SK (2006) Role of DREB transcription factors in abiotic and biotic stress tolerance in plants. *Plant Cell Rep* 25:1263–1274
- Aguilar PS, Hernandez-Arriaga AM, Cybulski LE, Erazo AC, deMendoza D (2001) Molecular basis of thermosensing: a two-component signal transduction thermometer in *Bacillus subtilis*. *EMBO J* 20:1681–1691
- Aharon R, Shahak Y, Wininger S, Bendov R, Kapulnik Y, Galili G (2003) Overexpression of a plasma membrane aquaporin in transgenic tobacco improves plant vigor under favorable growth conditions but not under drought or salt stress. *Plant Cell* 15:439–447
- Aida M, Ishida T, Fukaki H, Fujisawa H, Tasaka M (1997) Genes involved in organ separation in *Arabidopsis*: an analysis of the *cup-shaped cotyledon* mutant. *Plant Cell* 9:841–857
- Alia, Hayashi, H, Chen THH, Murata N (1998a) Transformation with a gene for choline oxidase enhances the cold tolerance of *Arabidopsis* during germination and early growth. *Plant Cell Environ* 21:232–239
- Alia HH, Sakamoto A, Murata N (1998b) Enhancement of the tolerance of *Arabidopsis* to high temperatures by genetic engineering of the synthesis of glycinebetaine. *Plant J* 16:155–161
- Apel K, Hirt H (2004) Reactive oxygen species: metabolism, oxidative stress, and signal transduction. *Annu Rev Plant Biol* 55:373–399
- Apse MP, Aharon GS, Snedden WA, Blumwald E (1999) Salt tolerance conferred by overexpression of a vacuolar Na<sup>+</sup>/H<sup>+</sup> antiporter in *Arabidopsis*. *Science* 285:1256–1258
- Arrillaga I, Gil Mascarell R, Gisbert C, Sales E, Montesinos C, Serrano R, Moreno V (1998) Expression of the yeast *HAL2* gene in tomato increases the *in vitro* salt tolerance of transgenic progenies. *Plant Sci* 136:219–226
- Babu R, Zhang J, Blum A, Ho D, Wu R, Nguyen HT (2004) HVA1, a LEA gene from barley confers dehydration tolerance in transgenic rice (*Oryza sativa* L.) via cell membrane protection. *Plant Sci* 166:855–862
- Badawi GH, Yamauchi Y, Shimada E, Sasaki R, Kawano N, Tanaka K, Tanaka K (2004) Enhanced tolerance to salt stress and water deficit by overexpressing superoxide dismutase in tobacco (*Nicotiana tabacum*) chloroplasts. *Plant Sci* 166:919–928
- Bajaj S, Mohanty A (2005) Recent advances in rice biotechnology-towards genetically superior transgenic rice. *Plant Biotech J* 3:275–307
- Barthakur S, Babu V, Bansal KC (2001) Overexpression of osmotin induces proline accumulation and confers tolerance to osmotic stress in transgenic tobacco. *J Plant Biotech* 10:31–37
- Berthomieu P, Conéjéro G, Nublat A, Brackenbury WJ, Lambert C, Savio C, Uozumi N, Oiki S, Yamada K, Cellier F, Gosti F, Simonneau T, Essah PA, Tester M, Véry AA, Sentenac H, Casse F (2003) Functional analysis of AtHKT1 in *Arabidopsis* shows that Na<sup>+</sup> recirculation by the phloem is crucial for salt tolerance. *EMBO J* 22:2004–2014
- Blokhina O, Virolainen E, Fagerstedt KV (2003) Antioxidants oxidative damage and oxygen deprivation stress: a review. *Ann Bot* 91:179–194
- Bohnert HJ, Jensen RG (1996) Strategies for engineering water stress tolerance in plants. *Trends Biotechnol* 14:89–97
- Bohnert HJ, Nelson DE, Jensen RG (1995) Adaptations to environmental stresses. *Plant Cell* 7:1099–1111
- Bordas M, Montesinos C, Dabauza M, Salvador A, Roig LA, Serrano R, Moreno V (1997) Transfer of the yeast salt tolerance gene *HAL1* to *Cucumis melo* L. cultivars and *in vitro* evaluation of salt tolerance. *Transgenic Res* 6:41–50
- Borovskii GB, Stupnikova IV, Antipina AI, Vladimirova SV, Voinikov VK (2002) Accumulation of dehydrin-like proteins in the mitochondria of cereals in response to cold, freezing, drought and ABA treatment. *BMC Plant Biol* 2:5
- Bowler C, Slooten L, Vandenbranden S, Rycke RD, Botterman J, Sybesma C, Montagu MV, Inze D (1991) Manganese superoxide dismutase can reduce cellular damage mediated by oxygen radicals in transgenic plants. *EMBO J* 10:1723–1732
- Brusegem FV, Vranova E, Dat JF, Inze D (2001) The role of active oxygen species in plant signal transduction. *Plant Sci* 161:405–414
- Brini F, Hanin M, Lumbreras V, Amara I, Khoudi H, Harsairi A, Pagès M, Masmoudi K (2007a) Overexpression of wheat dehydrin DHN-5 enhances tolerance to salt and osmotic stress in *Arabidopsis thaliana*. *Plant Cell Rep* 26:2017–2026
- Brini F, Hanin M, Mezghani I, Berkowitz GA, Masmoudi K (2007b) Overexpression of wheat Na<sup>+</sup>/H<sup>+</sup> antiporter *TNXX1* and H<sup>+</sup>-pyrophosphatase *TVPI* improve salt- and drought-stress tolerance in *Arabidopsis thaliana* plants. *J Exp Bot* 58:301–308
- Brouquisse R, Weigel P, Rhodes D, Yocum CF, Hanson AD (1989) Evidence for a ferredoxin-dependent choline monooxygenase from spinach chloroplast stroma. *Plant Physiol* 90:322–329
- Capell T, Escobar C, Lui H, Burtin D, Lepri O, Christou P (1998) Over-expression of the oat arginine decarboxylase cDNA in transgenic rice (*Oryza sativa* L.) affects normal development patterns *in vitro* and results in putrescine accumulation in transgenic plants. *Theor Appl Genet* 97:246–254

- Capell T, Bassie L, Christou P (2004) Modulation of the polyamine biosynthetic pathway in transgenic rice confers tolerance to drought stress. *Proc Natl Acad Sci USA* 101: 9909–9914
- Catalá R, Santos E, Alonso JM, Ecker JR, Martínez-Zapater JM, Salinas J (2003) Mutations in the  $\text{Ca}^{2+}/\text{H}^{+}$  transporter CAX1 increase CBF/DREB1 expression and the cold-acclimation response in *Arabidopsis*. *Plant Cell* 15: 2940–2951
- Cheng Z, Jayprakash T, Huang X, Wu R (2002) Wheat LEA genes, PMA80 and PMA1959, enhance dehydration tolerance of transgenic rice (*Oryza sativa* L.). *Mol Breed* 16:71–82
- Chiang YC, Stushnoff C, McSay AE, Jones ML, Bohnert HJ (2005) Overexpression of mannitol-1-phosphate dehydrogenase increases mannitol accumulation and adds protection against chilling injury in petunia. *J Am Soc Hort Sci* 130:605–610
- Chinnusamy V, Schumaker K, Zhu JK (2004) Molecular genetic perspectives on cross-talk and specificity in abiotic stress signalling in plants. *J Exp Bot* 55:225–236
- Ciftci-Yilmaz S, Morsy MR, Song L, Coutu A, Krizek BA, Lewis MW, Warren D, Cushman J, Connolly EL, Mittler R (2007) The EAR-motif of the Cys2/His2-type zinc finger protein Zat7 plays a key role in the defense response of *Arabidopsis* to salinity stress. *J Biol Chem* 282: 9260–9268
- Cominelli E, Galbiati M, Vavasseur A, Conti L, Sala T, Vuylsteke M, Leonhardt N, Dellaporta SL, Tonelli C (2005) A guard-cell-specific MYB transcription factor regulates stomatal movements and plant drought tolerance. *Curr Biol* 15:1196–1200
- D'Angeli S, Altamura MM (2007) Osmotin induces cold protection in olive trees by affecting programmed cell death and cytoskeleton organization. *Planta* 225:1147–1163
- Das-Chatterjee A, Goswami L, Maitra S, Dastidar KG, Ray S, Majumder AL (2006) Introgression of a novel salt-tolerant L-myo-inositol 1-phosphate synthase from *Porteresia coarctata* (Roxb.) Tateoka (PcINO1) confers salt tolerance to evolutionary diverse organisms. *FEBS Lett* 580:3980–3988
- Davletova S, Rizhsky L, Liang H, Shengqiang Z, Oliver DJ, Coutu J, Shulaev V, Schlauch K, Mittler R (2005a) Cytosolic ascorbate peroxidase 1 is a central component of the reactive oxygen gene network of *Arabidopsis*. *Plant Cell* 17:268–281
- Davletova S, Schlauch K, Coutu J, Mittler R (2005b) The zinc-finger protein Zat12 plays a central role in reactive oxygen and abiotic stress signaling in *Arabidopsis*. *Plant Physiol* 139:847–856
- Delauney AJ, Verma DPS (1993) Proline biosynthesis and osmoregulation in plants. *Plant J* 4:215–223
- Dure L (1992) The LEA proteins of higher plants. In: Verma DPS (ed) *Control of plant gene expression*. CRC Press, Boca Raton, FL, pp 325–335
- Dure L, Chlan C (1981) Developmental biochemistry of cotton seed embryogenesis and germination: XII. Purification and properties of principal storage proteins. *Plant Physiol* 68b:180–186
- Dure L, Galau GA (1981) Developmental biochemistry of cotton seed embryogenesis and germination: XIII. Regulation of biosynthesis of principal storage proteins. *Plant Physiol* 68:187–194
- Ellul P, Ríos G, Atarés A, Roig LA, Serrano R, Moreno V (2003) The expression of the *Saccharomyces cerevisiae* HAL1 gene increases salt tolerance in transgenic watermelon [*Citrullus lanatus* (Thunb.) Matsun. & Nakai.]. *Theor Appl Genet* 107:462–469
- Eltayeb AE, Kawano N, Badawi GH, Kaminaka H, Sanekata T, Shibahara T, Inanaga S, Tanaka K (2007) Overexpression of monodehydroascorbate reductase in transgenic tobacco confers enhanced tolerance to ozone, salt and polyethylene glycol stresses. *Planta* 225:1255–1264
- Fiorani F, Umbach AL, Siedow JN (2005) The alternative oxidase of plant mitochondria is involved in the acclimation of shoot growth at low temperature. A study of *Arabidopsis* AOX1a transgenic plants. *Plant Physiol* 139:1795–1805
- Fu D, Huang B, Xiao Y, Muthukrishnan S, Liang GH (2007) Overexpression of barley hva1 gene in creeping bentgrass for improving drought tolerance. *Plant Cell Rep* 26:467–477
- Fujita M, Fujita Y, Maruyama K, Seki M, Hiratsu K, Ohme-Takagi M, Tran LS, Yamaguchi-Shinozaki K, Shinozaki K (2004) A dehydration-induced NAC protein, RD26, is involved in a novel ABA-dependent stress-signaling pathway. *Plant J* 39:863–876
- Fukuda A, Yazaki Y, Ishikawa T, Koike S, Tanaka Y (1998)  $\text{Na}^{+}/\text{H}^{+}$  antiporter in tonoplast vesicles from rice roots. *Plant Cell Physiol* 39:196–201
- Fukuda A, Nakamura A, Tagiri A, Tanaka H, Miyao A, Hirochika H, Tanaka Y (2004) Function, intracellular localization and the importance in salt tolerance of a vacuolar  $\text{Na}^{+}/\text{H}^{+}$  antiporter from rice. *Plant Cell Physiol* 45:146–159
- Gaber A, Yoshimura K, Yamamoto T, Yabuta Y, Takeda T, Miyasaka H, Nakano Y, Shigeoka S (2006) Glutathione peroxidase-like protein of *Synechocystis* PCC 6803 confers tolerance to oxidative and environmental stresses in transgenic *Arabidopsis*. *Physiol Plant* 128:251–262
- Galinski EA, Pfeiffer HP, Truper HG (1985) 1, 4, 5, 6-Tetrahydro-2-methyl-4-pyrimidine carboxylic acid. A novel cyclic amino acid from halophilic phototrophic bacteria of the genus *Ectothiorhodospira*. *Eur J Biochem* 149: 135–139
- Gao F, Gao Q, Duan X, Yue G, Yang A, Zhang J (2006a) Cloning of an  $\text{H}^{+}$ -PPase gene from *Thellungiella halophila* and its heterologous expression to improve tobacco salt tolerance. *J Exp Bot* 57:3259–3270
- Gao G, Zhong Y, Guo A, Zhu Q, Tang W, Zheng W, Gu X, Wei L, Luo J (2006b) DRTF: a database of rice transcription factors. *Bioinformatics* 22:1286–1287

- Gao JP, Chao DY, Lin HX (2007) Understanding abiotic stress tolerance mechanisms: recent studies on stress response in rice. *J Integr Plant Biol* 49:742–750
- Garg AK, Kim JK, Owens TG, Ranwala AP, Choi YD, Kochian LV, Wu R (2002) Trehalose accumulation in rice plants confers high tolerance levels to different abiotic stresses. *Proc Natl Acad Sci USA* 99:15898–15903
- Gassman W, Rubio F, Schroeder JI (1996) Alkali cation selectivity of the wheat root high-affinity potassium transporter HKT1. *Plant J* 10:869–882
- Gaxiola RA, Rao R, Sherman A, Grisafi P, Alper SL, Fink GR (1999) The *Arabidopsis thaliana* proton transporters, AtNhx1 and Avp1, can function in cation detoxification in yeast. *Proc Natl Acad Sci USA* 96:1480–1485
- Gaxiola RA, Li J, Undurraga S, Dang LM, Allen GJ, Alper SL, Fink GR (2001) Drought- and salt-tolerant plants result from overexpression of the AVP1 H<sup>+</sup>-pump. *Proc Natl Acad Sci USA* 98:11444–11449
- Gisbert C, Rus AM, Bolarin MC, López-Coronado JM, Arrillaga I, Montesinos C, Caro M, Serrano R, Moreno V (2000) The yeast HAL1 gene improves salt tolerance of transgenic tomato. *Plant Physiol* 123:393–402
- Glenn EP, Brown JJ, Blumwald E (1999) Salt tolerance and crop potential of halophytes. *Crit Rev Plant Sci* 18: 227–256
- Goddijn OJM, Verwoerd TC, Voogd E, Krutwagen RW, de Graaf PT, van Dun K, Poels J, Ponstein AS, Damm B, Pen J (1997) Inhibition of trehalase activity enhances trehalose accumulation in transgenic plants. *Plant Physiol* 113:181–190
- Goddijn OJM, van Dun K (1999) Trehalose metabolism in plants. *Trends Plant Sci* 4:315–319
- Gong H, Jiao Y, Hu WW, Pua EC (2005) Expression of glutathione S-transferase and its role in plant growth and development in vivo and shoot morphogenesis in vitro. *Plant Mol Biol* 57:53–66
- Goyal K, Walton LJ, Tunnacliffe A (2005) LEA proteins prevent protein aggregation due to water stress. *Biochem J* 388:151–157
- Guo Y, Qiu QS, Quintero FJ, Pardo JM, Ohta M, Zhang C, Schumaker KS, Zhu JK (2004a) Transgenic evaluation of activated mutant alleles of SOS2 reveals a critical requirement for its kinase activity and C-terminal regulatory domain for salt tolerance in *Arabidopsis thaliana*. *Plant Cell* 16:435–449
- Guo ZJ, Chen XJ, Wu XL, Ling JQ, Xu P (2004b) Overexpression of the AP2/EREBP transcription factor OPBP1 enhances disease resistance and salt tolerance in tobacco. *Plant Mol Biol* 55:607–618
- Gupta AS, Heinen JI, Holaday S, Burket JJ, Allen RD (1993a) Increased resistance to oxidative stress in transgenic plants that overexpress chloroplastic Cu/Zn superoxide dismutase. *Proc Natl Acad Sci USA* 90:1629–1633
- Gupta AS, Robert P, Webb A, Holaday S, Allen RD (1993b) Overexpression of superoxide dismutase protects plants from oxidative stress. *Plant Physiol* 103:1067–1073
- Gutterson N, Reuber TL (2004) Regulation of disease resistance pathways by AP2/ERF transcription factors. *Curr Opin Plant Biol* 7:465–471
- Haake V, Cook D, Riechmann JL, Pineda O, Thomashow MF, Zhang JZ (2002) Transcription factor CBF4 is a regulator of drought adaptation in *Arabidopsis*. *Plant Physiol* 130:639–648
- Hamida-Sayari A, Gargouri-Bouزيد R, Bidani A, Jaoua L, Savoure A, Jaoua S (2005) Overexpression of  $\Delta^1$ -pyrroline-5-carboxylate synthetase increases proline production and confers salt tolerance in transgenic potato plants. *Plant Sci* 169:746–752
- Hara M, Terashima S, Fukaya T, Kuboi T (2003) Enhancement of cold tolerance and inhibition of lipid peroxidation by citrus dehydrin in transgenic tobacco. *Planta* 217: 290–298
- Hayashi H, Alia ML, Deshnum P, Ida M, Murata N (1997) Transformation of *Arabidopsis thaliana* with the codA gene for choline oxidase: accumulation of glycinebetaine and enhanced tolerance to salt and cold stress. *Plant J* 12:133–142
- He C, Yan J, Shen G, Fu L, Holaday AS, Auld D, Blumwald E, Zhang H (2005) Expression of an *Arabidopsis* vacuolar sodium/proton antiporter gene in cotton improves photosynthetic performance under salt conditions and increases fiber yield in the field. *Plant Cell Physiol* 46:1848–1854
- He PM, Zhang DB, Liang WQ, Yao QH, Zhang RX (2001) Expression of choline oxidase gene (codA) enhances salt tolerance of the tobacco. *Sheng Wu Hua Xue Yu Sheng Wu Wu Li Xue Bao (Shanghai)* 33:519–524
- Hirschi KD (1999) Expression of *Arabidopsis* CAX1 in tobacco: altered calcium homeostasis and increased stress sensitivity. *Plant Cell* 11:2113–2122
- Hirschi KD, Zhen RG, Cunningham KW, Rea PA, Fink GR (1996) CAX1, an H<sup>+</sup>/Ca<sup>2+</sup> antiporter from *Arabidopsis*. *Proc Natl Acad Sci USA* 93:8782–8786
- Holmberg N, Farrés J, Bailey JE, Kallio PT (2001) Targeted expression of a synthetic codon optimized gene, encoding the spruce budworm antifreeze protein, leads to accumulation of antifreeze activity in the apoplasts of transgenic tobacco. *Gene* 275:115–124
- Hong B, Uknes SJ, Ho THD (1988) Cloning and characterization of a cDNA encoding a mRNA rapidly-induced by ABA in barley aleurone layers. *Plant Mol Biol* 11:495–506
- Hu H, Dai M, Yao J, Xiao B, Li X, Zhang Q, Xiong L (2006) Overexpressing a NAM, ATAF, and CUC (NAC) transcription factor enhances drought resistance and salt tolerance in rice. *Proc Natl Acad Sci USA* 103:12987–12992
- Hu L, Lu H, Liu Q, Chen X, Jiang X (2005) Overexpression of mtLD gene in transgenic *Populus tomentosa* improves salt tolerance through accumulation of mannitol. *Tree Physiol* 25:1273–1281
- Huang J, Hirji R, Adam L, Rozwadowski KL, Hammerlindl JK, Keller WA, Selvaraj G (2000) Genetic engineering of glycine betaine production toward enhancing stress



- tolerance in plants: metabolic limitations. *Plant Physiol* 122:747–756
- Huang T, Nicodemus J, Zarka DG, Thomashow MF, Wisniewski M, Duman JG (2002) Expression of an insect (*Dendroides canadensis*) antifreeze protein in *Arabidopsis thaliana* results in a decrease in plant freezing temperature. *Plant Mol Biol* 50:333–344
- Huang Z, Zhang Z, Zhang X, Zhang H, Huang D, Huang R (2004) Tomato TERF1 modulates ethylene response and enhances osmotic stress tolerance by activating expression of downstream genes. *FEBS Lett* 573:110–116
- Iida K, Seki M, Sakurai T, Satou M, Akiyama K, Toyoda T, Konagaya A, Shinozaki K (2005) RARTF: database and tools for complete sets of *Arabidopsis* transcription factors. *DNA Res* 12:247–256
- Ikuta S, Imamura S, Misaki H, Horiuti Y (1977) Purification and characterization of choline oxidase from *Arthrobacter globiformis*. *J Biochem* 82:1741–1749
- Ito Y, Katsura K, Maruyama K, Taji T, Kobayashi M, Seki M, Shinozaki K, Yamaguchi-Shinozaki K (2006) Functional analysis of rice DREB1/CBF-type transcription factors involved in cold-responsive gene expression in transgenic rice. *Plant Cell Physiol* 47:141–153
- Jang IC, Oh SJ, Seo JS, Choi WB, Song SI, Kim CH, Kim YS, Seo HS, Choi YD, Nahm NM, Kim JK (2003) Expression of a bifunctional fusion of the *Escherichia coli* genes for trehalose-6-phosphate synthase and trehalose-6-phosphate phosphatase in transgenic rice plants increases trehalose accumulation and abiotic stress tolerance without stunting growth. *Plant Physiol* 131:516–524
- Jang JY, Lee SH, Rhee JY, Chung GC, Ahn SJ, Kang H (2007) Transgenic *Arabidopsis* and tobacco plants overexpressing an aquaporin respond differently to various abiotic stresses. *Plant Mol Biol* 64:621–632
- Jung J, Won SY, Suh SC, Kim H, Wing R, Jeong Y, Hwang I, Kim M (2007) The barley ERF-type transcription factor HvRAF confers enhanced pathogen resistance and salt tolerance in *Arabidopsis*. *Planta* 225:575–588
- Kang JY, Choi H, Im M, Kim SY (2002) *Arabidopsis* basic leucine zipper proteins that mediate stress-responsive abscisic acid signaling. *Plant Cell* 14:343–357
- Karaba A, Dixit S, Greco R, Aharoni A, Trijatmiko KR, Marsch-Martinez N, Krishnan A, Nataraja KN, Udayakumar M, Pereira A (2007) Improvement of water use efficiency in rice by expression of HARDY, an *Arabidopsis* drought and salt tolerance gene. *Proc Natl Acad Sci USA* 104:15270–15275
- Karakas B, Ozias-Akins P, Stushnoff C, Suefferheld M, Rieger M (1997) Salinity and drought tolerance of mannitol-accumulating transgenic tobacco. *Plant Cell Environ* 20:609–616
- Karim S, Aronsson H, Ericson H, Pirhonen M, Leyman B, Welin B, Mäntylä E, Palva ET, Van Dijk P, Holmström KO (2007) Improved drought tolerance without undesired side effects in transgenic plants producing trehalose. *Plant Mol Biol* 64:371–386
- Kasukabe Y, He L, Nada K, Misawa S, Ihara I, Tachibana S (2004) Overexpression of spermidine synthase enhances tolerance to multiple environmental stresses and up-regulates the expression of various stress-regulated genes in transgenic *Arabidopsis thaliana*. *Plant Cell Physiol* 45:712–722
- Katiyar-Agarwal S, Zhu J, Kim K, Agarwal M, Fu X, Huang A, Zhu JK (2006) The plasma membrane Na<sup>+</sup>/H<sup>+</sup> antiporter SOS1 interacts with RCD1 and functions in oxidative stress tolerance in *Arabidopsis*. *Proc Natl Acad Sci USA* 103:18816–18821
- Katsuhara M, Koshio K, Shibasaki M, Hayashi Y, Hayakawa T, Kasamo K (2003) Over-expression of a barley aquaporin increased the shoot/root ratio and raised salt sensitivity in transgenic rice plants. *Plant Cell Physiol* 44:1378–1383
- Katsuhara M, Otsuka T, Ezaki B (2005) Salt stress-induced lipid peroxidation is reduced by glutathione S-transferase, but this reduction of lipid peroxides is not enough for a recovery of root growth in *Arabidopsis*. *Plant Sci* 169:369–373
- Kavi Kishor PB, Hong Z, Miao GH, Hu CAA, Verma DPS (1995) Overexpression of  $\Delta^1$ -pyrroline-5-carboxylate synthetase increases proline production and confers osmotolerance in transgenic plants. *Plant Physiol* 108:1387–1394
- Kaye C, Neven L, Hofig A, Li QB, Haskell D, Guy C (1998) Characterization of a gene for spinach CAP160 and expression of two spinach cold-acclimation proteins in tobacco. *Plant Physiol* 116:1367–1377
- Kenward KD, Brandle J, McPherson J, Davies PL (1999) Type II fish antifreeze protein accumulation in transgenic tobacco does not confer frost resistance. *Transgenic Res* 8:105–117
- Khanna HK, Daggard GE (2006) Targeted expression of redesigned and codon optimised synthetic gene leads to recrystallisation inhibition and reduced electrolyte leakage in spring wheat at sub-zero temperatures. *Plant Cell Rep* 25:1336–1346
- Khokhlatchev AV, Canagarajah B, Wilsbacher J, Robinson M, Atkinson M, Goldsmith E, Cobb MH (1998) Phosphorylation of the MAP kinase ERK2 promotes its homodimerization and nuclear translocation. *Cell* 93:605–615
- Kim JC, Lee SH, Cheong YH, Yoo CM, Lee SI, Chun HJ, Yun DJ, Hong JC, Lee SY, Lim CO, Cho MJ (2001) A novel cold-inducible zinc finger protein from soybean, SCOF-1, enhances cold tolerance in transgenic plants. *Plant J* 25:247–259
- Kim MJ, Lim G, Kim E, Ko C, Yang K, Jeong J, Lee M, Kim CS (2007) Abiotic and biotic stress tolerance in *Arabidopsis* overexpressing the Multiprotein bridging factor 1a (MBF1a) transcriptional coactivator gene. *Biochem Biophys Res Commun* 354:440–446
- Komatsu S, Yang G, Khan M, Onodera H, Toki S, Yamaguchi M (2007) Over-expression of calcium-dependent protein kinase 13 and calreticulin interacting protein 1 con-

- fers cold tolerance on rice plants. *Mol Genet Genomics* 277:713–723
- Kovtun Y, Chiu WL, Tena G, Sheen J (2000) Functional analysis of oxidative stress-activated mitogen-activated protein kinase cascade in plants. *Proc Natl Acad Sci USA* 97:2940–2945
- Kühn H, Borchert A (2002) Regulation of enzymatic lipid peroxidation: the interplay of peroxidizing and peroxide reducing enzymes. *Free Radic Biol Med* 33:154–172
- Kumar S, Dhingra A, Daniell H (2004) Plastid-expressed betaine aldehyde dehydrogenase gene in carrot cultured cells, roots and leaves confers enhanced salt tolerance. *Plant Physiol* 136:2843–2854
- Kwon SY, Choi SM, Ahn YO, Lee HS, Lee HB, Park YM, Kwak SS (2003) Enhanced stress-tolerance of transgenic tobacco plants expressing a human dehydroascorbate reductase gene. *J Plant Physiol* 160:347–353
- Lal S, Gulyani V, Khurana P (2007) Overexpression of HVA1 gene from barley generates tolerance to salinity and water stress in transgenic mulberry (*Morus indica*). *Transgenic Res* 17:651–663
- Landfald B, Strom AR (1986) Choline-glycine betaine pathway confers a high level of osmotic tolerance in *Escherichia coli*. *J Bacteriol* 165:849–855
- Lee HE, Shin D, Park SR, Han SE, Jeong MJ, Kwon TR, Lee SK, Park SC, Yi BY, Kwon HB, Byun MO (2007a) Ethylene responsive element binding protein 1 (StEREBP1) from *Solanum tuberosum* increases tolerance to abiotic stress in transgenic potato plants. *Biochem Biophys Res Commun* 353:863–868
- Lee JH, Hong JP, Oh SK, Lee S, Choi D, Kim WT (2004a) The ethylene-responsive factor like protein 1 (CaERFLP1) of hot pepper (*Capsicum annuum* L.) interacts *in vitro* with both GCC and DRE/CRT sequences with different binding affinities: possible biological roles of CaERFLP1 in response to pathogen infection and high salinity conditions in transgenic tobacco plants. *Plant Mol Biol* 55:61–81
- Lee SC, Huh KW, An K, An G, Kim SR (2004b) Ectopic expression of a cold-inducible transcription factor, CBF1/DREB1b, in transgenic rice (*Oryza sativa* L.). *Mol Cells* 18:107–114
- Lee SH, Ahsan N, Lee KW, Kim DH, Lee DG, Kwak SS, Kwon SY, Kim TH, Lee BH (2007b) Simultaneous overexpression of both Cu/Zn superoxide dismutase and ascorbate peroxidase in transgenic tall fescue plants confers increased tolerance to a wide range of abiotic stresses. *J Plant Physiol* 164:1626–1638
- Lee YP, Kim SH, Bang JW, Lee HS, Kwak SS, Kwon SY (2007c) Enhanced tolerance to oxidative stress in transgenic tobacco plants expressing three antioxidant enzymes in chloroplasts. *Plant Cell Rep* 26:591–598
- Levitt J (1980) Responses of plants to environmental stresses, vol 1. Academic Press, New York
- Li J, Yang H, Peer WA, Richter G, Blakeslee J, Bandyopadhyay A, Titapiwantakun B, Undurraga S, Khodakovskaya M, Richards EL, Krizek B, Murphy AS, Gilroy S, Gaxiola R (2005) Arabidopsis H<sup>+</sup>-PPase AVP1 regulates auxin-mediated organ development. *Science* 310:121–125
- Li WYF, Wong FL, Tsai SN, Phang TH, Shao G, Lam HM (2006) Tonoplast-located GmCLC1 and GmNHX1 from soybean enhance NaCl tolerance in transgenic bright yellow (BY)-2 cells. *Plant Cell Environ* 29:1122–1137
- Lian HL, Yu X, Ye Q, Ding X, Kitagawa Y, Kwak SS, Su WA, Tang ZC (2004) The role of aquaporin RWC3 in drought avoidance in rice. *Plant Cell Physiol* 45:481–489
- Lilius G, Holmberg N, Bulow L (1996) Enhanced NaCl stress tolerance in transgenic tobacco expressing bacterial choline dehydrogenase. *Biotechnology* 14:177–180
- Lippert K, Galinski EA (1992) Enzyme stabilization by ectoine-type compatible solutes: protection against heating, freezing and drying. *App Microbiol Biotechnol* 37:61–65
- Liu Q, Kasuga M, Sakuma Y, Abe H, Miura S, Yamaguchi-Shinozaki K, Shinozaki K (1998) Two transcription factors, DREB1 and DREB2, with an EREBP/AP2 DNA binding domain separate two cellular signal transduction pathways in drought- and low-temperature-responsive gene expression, respectively, in *Arabidopsis*. *Plant Cell* 10:1391–1406
- Liu XF, Li JY (2002) Characterization of an ultra-violet inducible gene that encodes glutathione S-transferase in *Arabidopsis thaliana*. *Yi Chuan Xue Bao* 29:458–460
- Lu Z, Liu D, Liu S (2007) Two rice cytosolic ascorbate peroxidases differentially improve salt tolerance in transgenic *Arabidopsis*. *Plant Cell Rep* 26:1909–1917
- Luo GZ, Wang HW, Huang J, Tian AG, Wang YJ, Zhang JS, Chen SY (2005) A putative plasma membrane cation/proton antiporter from soybean confers salt tolerance in *Arabidopsis*. *Plant Mol Biol* 59:809–820
- Ma X, Qian Q, Zhu D (2005) Expression of a calcineurin gene improves salt stress tolerance in transgenic rice. *Plant Mol Biol* 58:483–495
- Maeda T, Wurgler-Murphy SM, Saito H (1994) A two-component system that regulates an osmosensing MAP kinase cascade in yeast. *Nature* 369:242–245
- Majee M, Maitra S, Dastidar KG, Pattnaik S, Chatterjee A, Hait NC, Das KP, Majumder AL (2004) A novel salt-tolerant L-myo-inositol-1-phosphate synthase from *Porteresia coarctata* (Roxb.) Tateoka, a halophytic wild rice: molecular cloning, bacterial overexpression, characterization, and functional introgression into tobacco-conferring salt tolerance phenotype. *J Biol Chem* 279:28539–28552
- Malik V, Wu R (2005) Transcription factor AtMyb2 increased salt-stress tolerance in rice (*Oryza sativa* L.). *Rice Genet Newslett* 22:63
- Martinez-Atienza J, Jiang X, Garcíadeblas B, Mendoza I, Zhu JK, Pardo JM, Quintero FJ (2007) Conservation of the salt overly sensitive pathway in rice. *Plant Physiol* 143:1001–1012
- Matsumura T, Tabayashi N, Kamagata Y, Souma C, Saruyama H (2002) Wheat catalase expressed in transgenic rice can improve tolerance against low temperature stress. *Physiol Plant* 116:317–327

- Maxwell DP, Wang Y, McIntosh L (1999) The alternative oxidase lowers mitochondrial reactive oxygen production in plant cells. *Proc Natl Acad Sci USA* 96:8271–8276
- McKersie BD, Chen Y, deBeus M, Bowley SR, Bowler C, Inzé D, D'Halluin K, Botterman J (1993) Superoxide dismutase enhances tolerance of freezing stress in transgenic alfalfa (*Medicago sativa* L.). *Plant Physiol* 103:1155–1163
- McKersie BD, Bowley SR, Harjanto E, Leprince O (1996) Water-deficit tolerance and field performance of transgenic alfalfa overexpressing superoxide dismutase. *Plant Physiol* 111:1177–1181
- McKersie BD, Bowley SR, Jones KS (1999) Winter survival of transgenic alfalfa overexpressing superoxide dismutase. *Plant Physiol* 119:839–848
- McKersie BD, Murnaghan J, Jones KS, Bowley SR (2000) Iron-superoxide dismutase expression in transgenic alfalfa increases winter survival without a detectable increase in photosynthetic oxidative stress tolerance. *Plant Physiol* 122:1427–1437
- McKown RL, Warren GJ (1991) Enhanced survival of yeast expressing an antifreeze gene analogue after freezing. *Cryobiology* 28:474–482
- Mendoza I, Quintero FJ, Bressan RA, Hasegawa PM, Pardo JM (1996) Activated calcineurin confers high tolerance to ion stress and alters the budding pattern and cell morphology of yeast cells. *J Biol Chem* 271:23061–23067
- Mengiste T, Chen X, Salmeron J, Dietrich R (2003) The BOTRYTIS SUSCEPTIBLE1 gene encodes an R2R3MYB transcription factor protein that is required for biotic and abiotic stress responses in *Arabidopsis*. *Plant Cell* 15:2551–2565
- Meyer K, Keil M, Naldrett MJ (1999) A leucine-rich repeat protein of carrot that exhibits antifreeze activity. *FEBS Lett* 447:171–178
- Miller G, Mittler R (2006) Could heat shock transcription factors function as hydrogen peroxide sensors in plants? *Ann Bot* 98:279–288
- Minocha SC, Sun DY (1997) Stress tolerance in plants through transgenic manipulation of polyamine biosynthesis. *Plant Physiol Supp* 114:297
- Mittler R, Zilinskas BA (1992) Molecular cloning and characterization of a gene encoding pea cytosolic ascorbate peroxidase. *J Biol Chem* 267:21802–21807
- Moghaieb RE, Tanaka N, Saneoka H, Hussein HA, Yousef SS, Ewada MA, Aly MAM, Fujita K (2000) Expression of betaine aldehyde dehydrogenase gene in transgenic tomato hairy roots leads to the accumulation of glycine betaine and contributes to the maintenance of osmotic potential under salt stress. *Soil Sci Plant Nutr* 46:873–883
- Moghaieb RE, Tanaka N, Saneoka H, Murooka Y, Ono H, Morikawa H, Nakamura A, Nguyen NT, Suwa R, Fujita K (2006) Characterization of salt tolerance in ectoine-transformed tobacco plants (*Nicotiana tabacum*): photosynthesis, osmotic adjustment, and nitrogen partitioning. *Plant Cell Environ* 29:173–182
- Mohanty A, Kathuria H, Ferjani A, Sakamoto A, Mohanty P, Murata N, Tyagi AK (2002) Transgenics of an elite *indica* rice variety Pusa Basmati-1 harbouring the *codA* gene are highly tolerant to salt stress. *Theor Appl Genet* 106:51–57
- Molinari HBC, Marura CJ, Filhoa JCB, Kobayashib AK, Pileggic M, Júniora RPL, Pereirad LFP, Vieiraa LGE (2004) Osmotic adjustment in transgenic citrus rootstock Carrizo citrange (*Citrus sinensis* Osb. x *Poncirus trifoliata* L. Raf.) overproducing proline. *Plant Sci* 167:1375–1381
- Molinari HBC, Marur CJ, Daros E, de Campos MKF, de Carvalho JFRP, Filho JCB, Pereira LFP, Vieira LGE (2007) Evaluation of the stress-inducible production of proline in transgenic sugarcane (*Saccharum spp.*): osmotic adjustment, chlorophyll fluorescence and oxidative stress. *Physiol Plant* 130:218–229
- Mukhopadhyay A, Vij S, Tyagi AK (2004) Overexpression of a zinc-finger protein gene from rice confers tolerance to cold, dehydration, and salt stress in transgenic tobacco. *Proc Natl Acad Sci USA* 101:6309–6314
- Nagamiya K, Motohashi T, Nakao K, Prodhan SH, Hattori E, Hirose S, Ozawa K, Ohkawa Y, Takabe T, Takabe T, Komamine A (2007) Enhancement of salt tolerance in transgenic rice expressing an *Escherichia coli* catalase gene, katE. *Plant Biotech Rep* 1:49–55
- Nakashima K, Tran LS, Van Nguyen D, Fujita M, Maruyama K, Todaka D, Ito Y, Hayashi N, Shinozaki K, Yamaguchi-Shinozaki K (2007) Functional analysis of a NAC-type transcription factor *OsNAC6* involved in abiotic and biotic stress-responsive gene expression in rice. *Plant J* 51:617–630
- Nakayama H, Yoshida K, Ono H, Murooka Y, Shinmyo A (2000) Ectoine, the compatible solute of *Halomonas elongata*, confers hyperosmotic tolerance in cultured tobacco cells. *Plant Physiol* 122:1239–1247
- Nelson DE, Rammesmayer G, Bohnert HJ (1998) Regulation of cell-specific inositol metabolism and transport in plant salinity tolerance. *Plant Cell* 10:753–764
- Nelson DE, Repetti PP, Adams TR, Creelman RA, Wu J, Warner DC, Anstrom DC, Bensen RJ, Castiglioni PP, Donnarummo MG, Hinchey BS, Kumimoto RW, Maszle DR, Canales RD, Krolkowski KA, Dotson SB, Gutterson N, Ratcliffe OJ, Heard JE (2007) Plant nuclear factor Y (NF-Y) B subunits confer drought tolerance and lead to improved corn yields on water-limited acres. *Proc Natl Acad Sci USA* 104:16450–16455
- Obata T, Kitamoto HK, Nakamura A, Fukuda A, Tanaka Y (2007) Rice shaker potassium channel OsKAT1 confers tolerance to salinity stress on yeast and rice cells. *Plant Physiol* 144:1978–1985
- Ogawa T, Pan L, Kawai-Yamada M, Yu LH, Yamamura S, Koyama T, Kitajima S, Ohme-Takagi M, Sato F, Uchimiya H (2005) Functional analysis of *Arabidopsis* ethylene-responsive element binding protein conferring resistance to Bax and abiotic stress-induced plant cell death. *Plant Physiol* 138:1436–1445

- Oh SJ, Song SI, Kim YS, Jang HJ, Kim SY, Kim M, Kim YK, Nahm BH, Kim JK (2005) *Arabidopsis* CBF3/DREB1A and ABF3 in transgenic rice increased tolerance to abiotic stress without stunting growth. *Plant Physiol* 138:341–351
- Ohta M, Hayashia Y, Nakashima A, Hamada A, Tanaka A, Nakamura T, Hayakawa T (2002) Introduction of a Na<sup>+</sup>/H<sup>+</sup> antiporter gene from *Atriplex gmelini* confers salt tolerance to rice. *FEBS Lett* 532:279–282
- Oraby HF, Ransom CB, Kravchenko AN, Sticklen MB (2005) Barley HVA1 gene confers salt tolerance in R3 transgenic oat. *Crop Sci* 45:2218–2227
- Pardo JM, Reddy MP, Yang S, Maggio A, Huh GH, Matsumoto T, Coca MA, Paino-D'Urzo M, Koiwa H, Yun DJ, Watad AA, Bressan RA, Hasegawa PM (1998) Stress signaling through Ca<sup>2+</sup>/calmodulin-dependent protein phosphatase calcineurin mediates salt adaptation in plants. *Proc Natl Acad Sci USA* 95:9681–9686
- Pareek A, Singh A, Kumar M, Kushwaha HR, Lynn AM, Singla-Pareek SL (2006) Whole-genome analysis of *Oryza sativa* reveals similar architecture of two-component signaling machinery with *Arabidopsis*. *Plant Physiol* 142:380–397
- Park BJ, Liu Z, Kanno A, Kameya T (2005a) Transformation of radish (*Raphanus sativus* L.) via sonication and vacuum infiltration of germinated seeds with *Agrobacterium* harboring a group 3 LEA gene from *B. napus*. *Plant Cell Rep* 24:494–500
- Park EJ, Jeknić Z, Sakamoto A, DeNoma J, Yuwansiri R, Murata N, Chen TH (2004) Genetic engineering of glycinebetaine synthesis in tomato protects seeds, plants, and flowers from chilling damage. *Plant J* 40:474–487
- Park EJ, Jeknić Z, Pino MT, Murata N, Chen TH (2007) Glycinebetaine accumulation is more effective in chloroplasts than in the cytosol for protecting transgenic tomato plants against abiotic stress. *Plant Cell Environ* 30:994–1005
- Park JM, Park CJ, Lee SB, Ham BK, Shin R, Paek KH (2001) Overexpression of the tobacco Tsi1 gene encoding an EREBP/AP2-type transcription factor enhances resistance against pathogen attack and osmotic stress in tobacco. *Plant Cell* 13:1035–1046
- Park S, Li J, Pittman JK, Berkowitz GA, Yang H, Undurraga S, Morris J, Hirschi KD, Gaxiola RA (2005b) Up-regulation of a H<sup>+</sup>-pyrophosphatase (H<sup>+</sup>-PPase) as a strategy to engineer drought-resistant crop plants. *Proc Natl Acad Sci USA* 102:18830–18835
- Parvanova D, Ivanov S, Konstantinova T, Karanov E, Atanasov A, Tsvetkov TS, Alexieva V, Djilianov D (2004) Transgenic tobacco plants accumulating osmolytes show reduced oxidative damage under freezing stress. *Plant Physiol Biochem* 42:57–63
- Paz-Ares J, Ghosal D, Wienand U, Peterson PA, Saedler H (1987) The regulatory c1 locus of *Zea mays* encodes a protein with homology to myb proto-oncogene products and with structural similarities to transcriptional activators. *EMBO J* 6:3553–3558
- Peng Y, Lin W, Cai W, Arora R (2007) Overexpression of a *Panax ginseng* tonoplast aquaporin alters salt tolerance, drought tolerance and cold acclimation ability in transgenic *Arabidopsis* plants. *Planta* 226:729–740
- Pitcher LH, Zilinskas BA (1996) Overexpression of copper/zinc superoxide dismutase in the cytosol of transgenic tobacco confers partial resistance to ozone-induced foliar necrosis. *Plant Physiol* 110:583–588
- Polidoros AN, Mylona PV, Scandalios JG (2001) Transgenic tobacco plants expressing the maize Cat2 gene have altered catalase levels that affect plant-pathogen interactions and resistance to oxidative stress. *Transgenic Res* 10:555–569
- Poovaliah BW, Reddy AS (1987) Calcium messenger system in plants. *CRC Crit Rev Plant Sci* 6:47–103
- Prabhavathi V, Yadav JS, Kumar PA, Rajam MV (2002) Abiotic stress tolerance in transgenic eggplant (*Solanum melongena* L.) by introduction of bacterial mannitol phosphohydrogenase gene. *Mol Breed* 9:137–147
- Prasad KVS, Pardha-Saradhi P (2004) Enhanced tolerance to photoinhibition in transgenic plants through targeting of glycine betaine biosynthesis into the chloroplasts. *Plant Sci* 166:1197–1212
- Prashanth SR, Sadhasivam V, Parida A (2007) Overexpression of cytosolic copper/zinc superoxide dismutase from a mangrove plant *Avicennia marina* in indica Rice var Pusa Basmati-1 confers abiotic stress tolerance. *Transgenic Res* 17:281–291
- Puhakainen T, Hess MW, Mäkelä P, Svensson J, Heino P, Palva ET (2004) Overexpression of multiple dehydrin genes enhances tolerance to freezing stress in *Arabidopsis*. *Plant Mol Biol* 54:743–753
- Qi YC, Zhang SM, Wang LP, Wang MD, Zhang H (2004) Overexpression of GST gene accelerates the growth of transgenic *Arabidopsis* under salt stress. *Zhi Wu Sheng Li Yu Fen Zi Sheng Wu Xue Xue Bao* 30:517–522
- Quan R, Shang M, Zhang H, Zhao Y, Zhang J (2004) Engineering of enhanced glycine betaine synthesis improves drought tolerance in maize. *Plant Biotech J* 2:477–486
- Rajagopal D, Agarwal P, Tyagi W, Singla-Pareek SL, Reddy MK, Sopory SK (2007) *Pennisetum glaucum* Na<sup>+</sup>/H<sup>+</sup> antiporter confers high level of salinity tolerance in transgenic *Brassica juncea*. *Mol Breed* 19:137–151
- Reddy AS (2001) Calcium: silver bullet in signaling. *Plant Sci* 160:381–404
- Rhodes D, Hanson AD (1993) Quaternary ammonium and tertiary sulfonium compounds in higher plants. *Ann Rev Plant Physiol Plant Mol Biol* 44:357–384
- Riano-Pachon DM, Ruzicic S, Dreyer I, Mueller-Roeber B (2007) PlnTFDB: an integrative plant transcription factor database. *BMC Bioinfo* 8:42
- Richards RA (1996) Defining selection criteria to improve yield under drought. *Plant Growth Regul* 20:57–166
- Rizhsky L, Davletova S, Liang H, Mittler R (2004) The zinc finger protein Zat12 is required for cytosolic ascorbate per-



- oxidase 1 expression during oxidative stress in *Arabidopsis*. *J Biol Chem* 279:11736–11743
- Rodriguez M, Canales E, Borrás-Hidalgo O (2005) Molecular aspects of abiotic stress in plants. *Biotechnol Appl* 22:1–10
- Rohila JS, Jain RK, Wu R (2002) Genetic improvement of basmati rice for salt and drought tolerance by regulated expression of a barley *HVA1* cDNA. *Plant Sci* 163:525–532
- Rorat T (2006) Plant dehydrins-tissue location, structure and function. *Cell Mol Biol Lett* 11:536–556
- Ross C, Shen QJ (2006) Computational prediction and experimental verification of HVA1-like abscisic acid responsive promoters in rice (*Oryza sativa*). *Plant Mol Biol* 62:233–246
- Roxas VP, Smith RK, Allen ER, Allen RD (1997) Overexpression of glutathione S-transferase/glutathione peroxidase enhances the growth of transgenic tobacco seedlings during stress. *Nat Biotech* 15:988–991
- Roxas VP, Lodhi SA, Garrett DK, Mahan JR, Allen RD (2000) Stress tolerance in transgenic tobacco seedlings that overexpress glutathione S-transferase/glutathione peroxidase. *Plant Cell Physiol* 41:1229–1234
- Roy M, Wu R (2001) Arginine decarboxylase transgene expression and analysis of environmental stress tolerance in transgenic rice. *Plant Sci* 160:869–875
- Roy M, Wu R (2002) Overexpression of S-adenosylmethionine decarboxylase gene in rice increases polyamine level and enhances sodium chloride-stress tolerance. *Plant Sci* 163:987–992
- RoyChoudhury A, Roy C, Sengupta DN (2007) Transgenic tobacco plants overexpressing the heterologous LEA gene Rab16A from rice during high salt and water deficit display enhanced tolerance to salinity stress. *Plant Cell Rep* 26:1839–1859
- Rubio F, Gassmann W, Schroeder JI (1995) Sodium-driven potassium uptake by the plant potassium transporter HKT1 and mutations conferring salt tolerance. *Science* 270:1660–1663
- Sahi C, Singh A, Kumar K, Blumwald E, Grover A (2006) Salt stress response in rice: genetics, molecular biology, and comparative genomics. *Funct Integr Genomics* 6:263–284
- Saijo Y, Hata S, Kyozuka J, Shimamoto K, Izui K (2000) Overexpression of a single Ca<sup>2+</sup>-dependent protein kinase confers both cold and salt/drought tolerance on rice plants. *Plant J* 23:319–327
- Sakamoto A, Alia, Murata N (1998) Metabolic engineering of rice leading to biosynthesis of glycine betaine and tolerance to salt and cold. *Plant Mol Biol* 38:1011–1019
- Sakamoto A, Valverde R, Alia CTHH, Murata N (2000) Transformation of *Arabidopsis* with the *codA* gene for choline oxidase enhances freezing tolerance of plants. *Plant J* 22:449–453
- Sakamoto H, Maruyama K, Sakuma Y, Meshi T, Iwabuchi M, Shinozaki K, Yamaguchi-Shinozaki K (2004) Arabidopsis Cys2/His2-type zinc-finger proteins function as transcription repressors under drought, cold and high-salinity stress conditions. *Plant Physiol* 136:2734–2746
- Samach A, Wigge PA (2005) Ambient temperature perception in plants. *Curr Opin Plant Biol* 8:483–486
- Sanan-Mishra N, Pham XH, Sopory SK, Tuteja N (2005) Pea DNA helicase 45 overexpression in tobacco confers high salinity tolerance without affecting yield. *Proc Natl Acad Sci USA* 102:509–514
- Sanan-Mishra N, Tuteja R, Tuteja N (2006) Signaling through MAP kinase networks in plants. *Arch Biochem Biophys* 452:55–68
- Sawahel WA, Hassan AH (2002) Generation of transgenic wheat plants producing high levels of the osmoprotectant proline. *Biotechnol Lett* 4:721–725
- Scandalios JG (1993) Oxygen stress and superoxide dismutases. *Plant Physiol* 101:7–12
- Schachtman DP, Schroeder JI (1994) Structure and transport mechanism of a high-affinity potassium uptake transporter from higher plants. *Nature* 370:655–658
- Shen B, Jensen RG, Bohnert HJ (1997) Increased resistance to oxidative stress in transgenic plants by targeting mannitol biosynthesis to chloroplasts. *Plant Physiol* 113:1177–1183
- Shen YG, Zhang WK, He SJ, Zhang JS, Liu Q, Chen SY (2003) An EREBP/AP2-type protein in *Triticum aestivum* was a DRE-binding transcription factor induced by cold, dehydration and ABA stress. *Theor Appl Genet* 106:923–930
- Sheveleva EV, Chmara W, Bohnert HJ, Jensen RG (1997) Increased salt and drought tolerance by D-ononitol production in transgenic *Nicotiana tabacum* L. *Plant Physiol* 115:1211–1219
- Sheveleva EV, Jensen RG, Bohnert HJ (2000) Disturbance in the allocation of carbohydrates to regenerative organs in transgenic *Nicotiana tabacum* L. *J Exp Bot* 51:115–122
- Shi H, Quintero FJ, Pardo JM, Zhu JK (2002) The putative plasma membrane Na<sup>+</sup>/H<sup>+</sup> antiporter SOS1 controls long-distance Na<sup>+</sup> transport in plants. *Plant Cell* 14:465–477
- Shi WM, Muramoto Y, Ueda A, Takabe T (2001) Cloning of peroxisomal ascorbate peroxidase gene from barley and enhanced thermotolerance by overexpressing in *Arabidopsis thaliana*. *Gene* 273:23–27
- Shimamura C, Ohno R, Nakamura C, Takumi S (2006) Improvement of freezing tolerance in tobacco plants expressing a cold-responsive and chloroplast-targeting protein WCOR15 of wheat. *J Plant Physiol* 163:213–219
- Shirasawa K, Takabe T, Takabe T, Kishitani S (2006) Accumulation of glycinebetaine in rice plants that overexpress choline monoxygenase from spinach and evaluation of their tolerance to abiotic stress. *Ann Bot* 98:565–571
- Shou H, Bordallo P, Fan JB, Yeakley JM, Bibikova M, Sheen J, Wang K (2004) Expression of an active tobacco mitogen-activated protein kinase kinase kinase enhances freezing tolerance in transgenic maize. *Proc Natl Acad Sci USA* 101:3298–3303

- Sickler CM, Edwards GE, Kiirats O, Zhifang G, Loescher WH (2007) Response of mannitol-producing *Arabidopsis thaliana* to abiotic stress. *Func Plant Biol* 34:382–391
- Siefritz F, Tyree MT, Lovisolo C, Schubert A, Kaldenhoff R (2002) PIP1 plasma membrane aquaporins in tobacco: from cellular effects to function in plants. *Plant Cell* 14:869–876
- Singh AK, Ansari MW, Pareek A, Singla-Pareek SL (2008) Raising salinity tolerant rice: recent progress and future perspectives. *Physiol Mol Biol Plants* 14:137–154
- Singla-Pareek SL, Reddy MK, Sopory SK (2001) Transgenic approach towards developing abiotic stress tolerance in plants. *Proc Ind Nat Sci Acad* 67:265–284
- Singla-Pareek SL, Reddy MK, Sopory SK (2003) Genetic engineering of the glyoxalase pathway in tobacco leads to enhanced salinity tolerance. *Proc Natl Acad Sci USA* 100:14672–14677
- Singla-Pareek SL, Yadav SK, Pareek A, Reddy MK, Sopory SK (2006) Transgenic tobacco overexpressing glyoxalase pathway enzymes grow and set viable seeds in zinc-spiked soils. *Plant Physiol* 140:613–623
- Singla-Pareek SL, Yadav SK, Pareek A, Reddy MK, Sopory SK (2007) Enhancing salt tolerance in a crop plant by overexpression of glyoxalase II. *Transgenic Res* 17:171–180
- Sivamani E, Bahieldin A, Wraith JM, Al-Niemi T, Dyer WE, Ho THD, Qu R (2000) Improved biomass productivity and water use efficiency under water deficit conditions in transgenic wheat constitutively expressing the barley HVA1 gene. *Plant Sci* 155:1–9
- Slooten L, Capiou K, Van Camp W, Montagu MV, Sybesma C, Inzé D (1995) Factors affecting the enhancement of oxidative stress tolerance in transgenic tobacco overexpressing manganese superoxide dismutase in the chloroplasts. *Plant Physiol* 107:737–750
- Smirnoff N, Pallanca JE (1996) Ascorbate metabolism in relation to oxidative stress. *Biochem Soc Trans* 24:472–478
- Snedden WA, Fromm H (2001) Calmodulin as a versatile calcium signal transducer in plants. *New Phytol* 151:35–66
- Sohn KH, Lee SC, Jung HW, Hong JK, Hwang BK (2006) Expression and functional roles of the pepper pathogen-induced transcription factor RAV1 in bacterial disease resistance, and drought and salt stress tolerance. *Plant Mol Biol* 61:897–915
- Stockinger EJ, Gilmour SJ, Thomashow MF (1997) *Arabidopsis thaliana* CBF1 encodes an AP2 domain-containing transcriptional activator that binds to the C-repeat/DRE, a cis-acting DNA regulatory element that stimulates transcription in response to low temperature and water deficit. *Proc Natl Acad Sci USA* 94:1035–1040
- Su J, Wu R (2004) Stress-inducible synthesis of proline in transgenic rice confers faster growth under stress conditions than that with constitutive synthesis. *Plant Sci* 166:941–948
- Su J, Hirji R, Zhang L, He C, Selvaraj G, Wu R (2006) Evaluation of the stress-inducible production of choline oxidase in transgenic rice as a strategy for producing the stress-protectant glycine betaine. *J Exp Bot* 57:1129–1135
- Sugano S, Kaminaka H, Rybka Z, Catala R, Salinas J, Matsui K, Ohme-Takagi M, Takatsuji H (2003) Stress-responsive zinc finger gene ZPT2–3 plays a role in drought tolerance in petunia. *Plant J* 36:830–841
- Sugie A, Naydenov N, Mizuno N, Nakamura C, Takumi S (2006) Overexpression of wheat alternative oxidase gene Waox1a alters respiration capacity and response to reactive oxygen species under low temperature in transgenic *Arabidopsis*. *Genes Genet Syst* 81:349–354
- Sulpice R, Tsukaya H, Nonaka H, Mustardy L, Chen THH, Murata N (2003) Enhanced formation of flowers in salt-stressed *Arabidopsis* after genetic engineering of the synthesis of glycine betaine. *Plant J* 36:165–176
- Sunarpi HT, Motoda J, Kubo M, Yang H, Yoda K, Horie R, Chan WY, Leung HY, Hattori K, Konomi M, Osumi M, Yamagami M, Schroeder JI, Uozumi N (2005) Enhanced salt tolerance mediated by AtHKT1 transporter-induced Na unloading from xylem vessels to xylem parenchyma cells. *Plant J* 44:928–938
- Suzuki I, Kanesaki Y, Mikami K, Kanehisa M, Murata N (2000) Cold-regulated genes under control of the cold sensor Hik33 in *Synechocystis*. *Mol Microbiol* 40:235–244
- Tamminen I, Makela P, Heino P, Palva ET (2001) Ectopic expression of ABI3 gene enhances freezing tolerance in response to abscisic acid and low temperature in *Arabidopsis thaliana*. *Plant J* 25:1–8
- Tamura T, Hara K, Yamaguchi Y, Koizumi N, Sano H (2003) Osmotic stress tolerance of transgenic tobacco expressing a gene encoding a membrane-located receptor-like protein from tobacco plants. *Plant Physiol* 131:454–462
- Tanaka Y, Hibino T, Hayashi Y, Tanaka A, Kishitani S, Takabe T, Yokota S, Takabe T (1999) Salt tolerance of transgenic rice overexpressing yeast mitochondrial Mn-SOD in chloroplasts. *Plant Sci* 148:131–138
- Tang L, Kwon SY, Kim SH, Kim JS, Choi JS, Cho KY, Sung CK, Kwak SS, Lee HS (2006) Enhanced tolerance of transgenic potato plants expressing both superoxide dismutase and ascorbate peroxidase in chloroplasts against oxidative stress and high temperature. *Plant Cell Rep* 25:1380–1386
- Tang W, Peng X, Newton RJ (2005) Enhanced tolerance to salt stress in transgenic loblolly pine simultaneously expressing two genes encoding mannitol-1-phosphate dehydrogenase and glucitol-6-phosphate dehydrogenase. *Plant Physiol Biochem* 43:139–146
- Tarczynski MC, Jensen RG, Bohnert HJ (1992) Expression of a bacterial mtLD gene in transgenic tobacco leads to production and accumulation of mannitol. *Proc Natl Acad Sci USA* 89:2600–2604
- Tarczynski MC, Jensen RG, Bohnert HJ (1993) Stress protection of transgenic tobacco by production of the osmolyte mannitol. *Science* 259:508–510
- Tausz M, Sircelj H, Grill D (2004) The glutathione system as a stress marker in plant ecophysiology: is a stress-response concept valid? *J Exp Bot* 55:1955–1962

- Teige M, Scheikl E, Eulgem T, Dóczy R, Ichimura K, Shinozaki K, Dangel JL, Hirt H (2004) The MKK2 pathway mediates cold and salt stress signaling in *Arabidopsis*. *Mol Cells* 15:141–152
- Thomas JC, Sepahi M, Arendall B, Bohnert HJ (1995) Enhancement of seed germination in high salinity by engineering mannitol expression in *Arabidopsis thaliana*. *Plant Cell Environ* 18:801–806
- Tomczak MM, Hinch DK, Estrada SD, Wolkers WF, Crowe LM, Feeney RE, Tablin F, Crowe JH (2002) A mechanism for stabilization of membranes at low temperatures by an antifreeze protein. *Biophys J* 82:874–881
- Tran LSP, Urao T, Qin F, Maruyama K, Kakimoto T, Shinozaki K, Yamaguchi-Shinozaki K (2007) Functional analysis of AHK1/ATHK1 and cytokinin receptor histidine kinases in response to abscisic acid, drought, and salt stress in *Arabidopsis*. *Proc Natl Acad Sci USA* 104:20623–20628
- Tunnacliffe A, Wise MJ (2007) The continuing conundrum of the LEA proteins. *Naturwissenschaften* 94:791–812
- Umbach AL, Fiorani F, Siedow JN (2005) Characterization of transformed *Arabidopsis* with altered alternative oxidase levels and analysis of effects on reactive oxygen species in tissue. *Plant Physiol* 139:1806–1820
- Uozumi N, Kim EJ, Rubio F, Yamaguchi T, Muto S, Tsuboi A, Bakker EP, Nakamura T, Schroeder JI (2000) The *Arabidopsis* HKT1 gene homolog mediates inward Na<sup>+</sup> currents in *Xenopus laevis* oocytes and Na<sup>+</sup> uptake in *Saccharomyces cerevisiae*. *Plant Physiol* 122:1249–1259
- Urao T, Yakubov B, Satoh R, Yamaguchi-Shinozaki K, Seki M, Hirayama T, Shinozaki K (1999) A transmembrane hybrid-type histidine kinase in *Arabidopsis* functions as an osmosensor. *Plant Cell* 11:1743–1754
- Ushimaru T, Nakagawa T, Fujioka Y, Daicho K, Naito M, Yamauchi Y, Nonaka H, Amako K, Yamawaki K, Murata N (2006) Transgenic *Arabidopsis* plants expressing the rice dehydroascorbate reductase gene are resistant to salt stress. *J Plant Physiol* 163:1179–1184
- Van Camp W, Willekens H, Bowler C, Van Montagu M, Inzé D, Reupold-Popp R, Sandman H Jr, Langebartel SC (1994) Elevated levels of superoxide dismutase protect transgenic plants against ozone damage. *Biotechnology* 12:165–168
- Van Camp W, Capiou K, Van Montagu M, Inzé D, Slooten L (1996) Enhancement of oxidative stress tolerance in transgenic tobacco plants overproducing Fe-superoxide dismutase in chloroplasts. *Plant Physiol* 112:1703–1714
- Veena, Reddy VS, Sopory SK (1999) Glyoxalase I from *Brassica juncea*: molecular cloning, regulation and its over-expression confer tolerance in transgenic tobacco under stress. *Plant J* 17:385–395
- Verma D, Singla-Pareek SL, Rajagopal D, Reddy MK, Sopory SK (2007) Functional validation of a novel isoform of Na<sup>+</sup>/H<sup>+</sup> antiporter from *Pennisetum glaucum* for enhancing salinity tolerance in rice. *J Biosci* 32:621–628
- Vij S, Tyagi AK (2007) Emerging trends in the functional genomics of the abiotic stress response in crop plants. *Plant Biotechnol J* 5:361–380
- Villalobos MA, Bartels D, Iturriaga G (2004) Stress tolerance and glucose insensitive phenotypes in *Arabidopsis* overexpressing the CpMYB10 transcription factor gene. *Plant Physiol* 135:309–324
- Vinocur B, Altman A (2005) Recent advances in engineering plant tolerance to abiotic stress: achievements and limitations. *Curr Opin Biotech* 16:123–132
- Waie B, Rajam MV (2003) Effect of increased polyamine biosynthesis on stress responses in transgenic tobacco by introduction of human S-adenosylmethionine gene. *Plant Sci* 164:727–734
- Wang FZ, Wang QB, Kwon SY, Kwak SS, Su WA (2005a) Enhanced drought tolerance of transgenic rice plants expressing a pea manganese superoxide dismutase. *J Plant Physiol* 162:465–472
- Wang H, Huang Z, Chen Q, Zhang Z, Zhang H, Wu Y, Huang D, Huang R (2004a) Ectopic overexpression of tomato JERF3 in tobacco activates downstream gene expression and enhances salt tolerance. *Plant Mol Biol* 55:183–192
- Wang J, Zhang H, Allen RD (1999) Overexpression of an *Arabidopsis* peroxisomal ascorbate peroxidase gene in tobacco increases protection against oxidative stress. *Plant Cell Physiol* 40:725–732
- Wang Y, Ying Y, Chen J, Wang X (2004b) Transgenic *Arabidopsis* overexpressing Mn-SOD enhanced salt-tolerance. *Plant Sci* 167:671–677
- Wang Y, Wisniewski M, Meilan R, Cui M, Fuchigami L (2006) Transgenic tomato (*Lycopersicon esculentum*) overexpressing cAPX exhibits enhanced tolerance to UV-B and heat stress. *J Appl Hort* 8:87–90
- Wang YJ, Wisniewski M, Wisniewski M, Meilan R, Cui MG, Webb R, Fuchigami L (2005b) Overexpression of cytosolic ascorbate peroxidase in tomato (*Lycopersicon esculentum* L.) confers tolerance to chilling and salt stress. *J Am Soc Hort Sci* 130:167–173
- Weigel P, Weretilnyk EA, Hanson AD (1986) Betaine aldehyde oxidation by spinach chloroplasts. *Plant Physiol* 82:753–759
- White PJ, Broadley MR (2003) Calcium in plants. *Ann Bot* 92:487–511
- Wi SJ, Park KY (2002) Antisense expression of carnation cDNA encoding ACC synthase or ACC oxidase enhances polyamine content and abiotic stress tolerance in transgenic tobacco plants. *Mol Cells* 13:209–220
- Wilken DR, McMacken ML, Rodriguez A (1970) Choline and betaine aldehyde oxidation by rat liver mitochondria. *Biochim Biophys Acta* 216:305–317
- Willekens H, Inzé D, Van Montagu M, Van Camp W (1995) Catalase in plants. *Mol Breed* 1:207–228
- Wingler A, Fritzius T, Wiemken A, Boller T, Aeschbacher RA (2002) Trehalose induced the ADP-glucose pyrophosphorylase gene, ApL3, and starch synthesis in *Arabidopsis*. *Plant Physiol* 124:105–114

- Winicov I, Bastola DR (1999) Transgenic overexpression of the transcription factor Alfin1 enhances expression of the endogenous MsPRP2 gene in alfalfa and improves salinity tolerance of the plants. *Plant Physiol* 120:473–480
- Worrall D, Elias L, Ashford D, Smallwood M, Sidebottom C, Lillford P, Telford J, Holt C, Bowles D (1998) A carrot leucine-rich-repeat protein that inhibits ice recrystallization. *Science* 282:115–117
- Wu CA, Yang GD, Meng QW, Zheng CC (2004) The cotton *GhNHX1* gene encoding a novel putative tonoplast Na<sup>+</sup>/H<sup>+</sup> antiporter plays an important role in salt stress. *Plant Cell Physiol* 45:600–607
- Wu CQ, Hu HH, Zeng Y, Liang DC, Xie KB, Zhang JW, Chu ZH, Xiong LZ (2006) Identification of novel stress-responsive transcription factor genes in rice by cDNA array analysis. *J Integr Plant Biol* 48:1216–1224
- Wu L, Chen X, Ren H, Zhang Z, Zhang H, Wang J, Wang XC, Huang R (2007a) ERF protein JERF1 that transcriptionally modulates the expression of abscisic acid biosynthesis-related gene enhances the tolerance under salinity and cold in tobacco. *Planta* 226:815–825
- Wu Y, Ding N, Zhao X, Zhao M, Chang Z, Liu J, Zhang L (2007b) Molecular characterization of PeSOS1: the putative Na<sup>+</sup>/H<sup>+</sup> antiporter of *Populus euphratica*. *Plant Mol Biol* 65:1–11
- Xiao B, Huang Y, Tang N, Xiong L (2007) Over-expression of a LEA gene in rice improves drought resistance under the field conditions. *Theor Appl Genet* 115:35–46
- Xiao-Yan Y, Fang YA, Wei ZK, Ren ZJ (2004) Production and analysis of transgenic maize with improved salt tolerance by the introduction of AtNHX1 gene. *Acta Bot Sinica* 46:854–861
- Xiong L, Zhu JK (2002) Molecular and genetic aspects of plant responses to osmotic stress. *Plant Cell Environ* 25:131–139
- Xiong L, Yang Y (2003) Disease resistance and abiotic stress tolerance in rice are inversely modulated by an abscisic acid-inducible mitogen-activated protein kinase. *Plant Cell* 15:745–759
- Xiong L, Schumaker KS, Zhu JK (2002) Cell signaling during cold, drought, and salt stress. *Plant Cell* 14:165–183
- Xu D, Duan X, Wang B, Hong B, Ho THD, Wu R (1996) Expression of a late embryogenesis abundant protein gene, HVA7, from barley confers tolerance to water deficit and salt stress in transgenic rice. *Plant Physiol* 110:249–257
- Xu ZS, Xia LQ, Chen M, Cheng XG, Zhang RY, Li LC, Zhao YX, Lu Y, Ni ZY, Liu L, Qiu ZG, Ma YZ (2007) Isolation and molecular characterization of the *Triticum aestivum* L. ethylene-responsive factor 1 (TaERF1) that increases multiple stress tolerance. *Plant Mol Biol* 65:719–732
- Xue ZY, Zhi DY, Xue GP, Zhang H, Zhao YX, Xia GM (2004) Enhanced salt tolerance of transgenic wheat (*Triticum aestivum* L.) expressing a vacuolar Na<sup>+</sup>/H<sup>+</sup> antiporter gene with improved yields in saline soils in the field and a reduced level of leaf Na<sup>+</sup>. *Plant Sci* 167:849–859
- Yamada M, Morishita H, Urano K, Shiozaki N, Yamaguchi-Shinozaki K, Shinozaki K, Yoshida Y (2005) Effects of free proline accumulation in petunias under drought stress. *J Exp Bot* 56:1975–1981
- Yamaguchi T, Blumwald E (2005) Developing salt-tolerant crop plants: challenges and opportunities. *Trends Plants Sci* 10:615–620
- Yamaguchi-Shinozaki K, Shinozaki K (1994) A novel cis-acting element in an *Arabidopsis* gene is involved in responsiveness to drought, low-temperature, or high-salt stress. *Plant Cell* 6:251–264
- Yamaguchi-Shinozaki K, Shinozaki K (2005) Organization of cis-acting regulatory elements in osmotic- and cold-stress-responsive promoters. *Trends Plant Sci* 10:88–94
- Yan J, Wang J, Tissue D, Holaday S, Allen R, Zhang H (2003) Protection of photosynthesis and seed production under water-deficit conditions in transgenic tobacco plants that over-express *Arabidopsis* ascorbate peroxidase. *Crop Sci* 43:1477–1483
- Yang SX, Zhao YX, Zhang Q, He YK, Zhang H, Luo D (2001) HAL1 mediate salt adaptation in *Arabidopsis thaliana*. *Cell Res* 11:142–148
- Yang T, Poovaiah BW (2003) Calcium/calmodulin-mediated signal network in plants. *Trends Plant Sci* 8:505–512
- Yang X, Liang Z, Lu C (2005) Genetic engineering of the biosynthesis of glycinebetaine enhances photosynthesis against high temperature stress in transgenic tobacco plants. *Plant Physiol* 138:2299–2309
- Yeo ET, Kwon HB, Han SE, Lee JT, Ryu JC, Byu MO (2000) Genetic engineering of drought resistant potato plants by introduction of the trehalose-6-phosphate synthase (TPS1) gene from *Saccharomyces cerevisiae*. *Mol Cells* 10:263–268
- Yoo JH, Park CY, Kim JC, Heo WD, Cheong MS, Park HC, Kim MC, Moon BC, Choi MS, Kang YH, Lee JH, Kim HS, Lee SM, Yoon HW, Lim CO, Yun DJ, Lee SY, Chung WS, Cho MJ (2005) Direct interaction of a divergent CaM isoform and the transcription factor, MYB2, enhances salt tolerance in *Arabidopsis*. *J Biol Chem* 280:3697–3706
- Yoshimura K, Miyao K, Gaber A, Takeda T, Kanaboshi H, Miyasaka H, Shigeoka S (2004) Enhancement of stress tolerance in transgenic tobacco plants overexpressing *Chlamydomonas* glutathione peroxidase in chloroplasts or cytosol. *Plant J* 37:21–33
- Yu T, Li YS, Chen XF, Hu J, Chang X, Zhu YG (2003) Transgenic tobacco plants overexpressing cotton glutathione S-transferase (GST) show enhanced resistance to methyl viologen. *J Plant Physiol* 160:1305–1311
- Zhang H, Huang Z, Xie B, Chen Q, Tian X, Zhang X, Zhang H, Lu X, Huang D, Huang R (2004) The ethylene-, jasmonate-, abscisic acid- and NaCl-responsive tomato transcription factor JERF1 modulates expression of GCC box-containing genes and salt tolerance in tobacco. *Planta* 220:262–270
- Zhang HX, Blumwald E (2001) Transgenic salt-tolerant tomato plants accumulate salt in foliage but not in fruit. *Nat Biotech* 19:765–768



- Zhang HX, Hodson JN, Williams JP, Blumwald E (2001a) Engineering salt-tolerant *Brassica* plants: characterization of yield and seed oil quality in transgenic plants with increased vacuolar sodium accumulation. *Proc Natl Acad Sci USA* 98:12832–12836
- Zhao F, Zhang H (2006) Salt and paraquat stress tolerance results from co-expression of the *Suaeda salsa* glutathione S-transferase and catalase in transgenic rice. *Plant Cell Tissue Org Cult* 86:349–358
- Zhao F, Wang Z, Zhang Q, Zhao Y, Zhang H (2006a) Analysis of the physiological mechanism of salt-tolerant transgenic rice carrying a vacuolar Na<sup>+</sup>/H<sup>+</sup> antiporter gene from *Suaeda salsa*. *J Plant Res* 119:95–104
- Zhao F, Guo S, Zhang H, Zhao Y (2006b) Expression of yeast *SOD2* in transgenic rice results in increased salt tolerance. *Plant Sci* 170:216–224
- Zhifang G, Loescher WH (2003) Expression of a celery mannose-6-phosphate reductase in *Arabidopsis thaliana* enhances salt tolerance and induces biosynthesis of both mannitol and a glucosyl-mannitol dimer. *Plant Cell Environ* 26:275–283
- Zhu B, Chen TH, Li PH (1995) Activation of two osmotin-like protein genes by abiotic stimuli and fungal pathogen in transgenic potato plants. *Plant Physiol* 108:929–937
- Zhu B, Chen TH, Li PH (1996) Analysis of late-blight disease resistance and freezing tolerance in transgenic potato plants expressing sense and antisense genes for an osmotin-like protein. *Planta* 198:70–77
- Zhu B, Su J, Chang M, Verma DPS, Fan YL, Wu R (1998) Overexpression of a  $\Delta^1$ -pyrroline-5-carboxylate synthetase gene and analysis of tolerance to water- and salt-stress in transgenic rice. *Plant Sci* 139:41–48
- Zhu JK (2001) Cell signaling under salt, water and cold stresses. *Curr Opin Plant Biol* 4:401–406
- Zhu JK (2002) Salt and drought stress signal transduction in plants. *Annu Rev Plant Biol* 53:247–273

# Chapter 20

## Marker Assisted Breeding

Michael J. Thomson, Abdelbagi M. Ismail\*, Susan R. McCouch,  
and David J. Mackill

*MJT, AMI, DJM: International Rice Research Institute (IRRI),  
DAPO Box 7777, Metro Manila,  
Philippines*

*SRM: Department of Plant Breeding and Genetics, Cornell University,  
162 Emerson Hall, Ithaca, NY 14853-1901, USA*

Summary .....	452
I Introduction .....	452
II Molecular Markers as Tools for Dissecting Quantitative Traits .....	453
A Dissecting Complex Traits Using QTL Mapping.....	454
B Gene Discovery: Genomics and Positional Cloning.....	454
C Strategies for Marker-Assisted Selection.....	455
III Case Studies from a Model Crop: MAS for Abiotic Stress Tolerance in Rice .....	457
A Flooding.....	458
B Salinity.....	458
C Phosphorus Deficiency.....	460
D Drought.....	461
IV Future Perspectives.....	462
A Association Mapping for Abiotic Stress Tolerance.....	462
B Variety Development and Gene Deployment .....	463
C Bioinformatics Supporting Molecular Breeding.....	464
1 Integrating Marker Genotype and Plant Phenotype Data.....	464
2 Using a Gene and Plant Ontology.....	464
3 Databases for the Next Generation of Plant Breeders .....	465
V Conclusions.....	465
Acknowledgements .....	466
References .....	466

---

\* Author for Correspondence, e-mail: [abdelbagi.ismail@cgiar.org](mailto:abdelbagi.ismail@cgiar.org)

## Summary

Recent advances in understanding molecular and physiological mechanisms of abiotic stress responses, along with breakthroughs in molecular marker technologies, have enabled the dissection of the complex traits underlying stress tolerance in crop plants. Quantitative trait loci (QTLs) controlling different abiotic stress traits form the basis for a precise marker-assisted backcrossing (MABC) strategy to rapidly transfer tolerance loci into high-yielding, but stress-sensitive varieties. Case studies are presented to demonstrate the progress and potential for MABC programs to develop rice varieties with increased tolerance to flooding, salinity, phosphorus deficiency and drought, amongst others. Future opportunities exist for employing association genetics for more efficient allele mining for abiotic stress tolerance from germplasm collections, as well as leveraging the power of bioinformatics and genomics data for more efficient trait dissection and use in breeding. Plant breeders now have a wealth of information and tools available to tackle these serious constraints posed by abiotic stresses, with the promise of delivering stable, high yielding varieties, able to thrive in the increasingly degrading soils and the ominously changing environment.

**Keywords** abiotic stresses • association mapping • *Oryza sativa* L. • QTLs • rice

## I Introduction

As reviewed in previous chapters, abiotic stress responses consist of complex and dynamic systems which allow plants to deal with the manifold stresses encountered in variable environments. The pattern of plant diversity across the various ecosystems around the world represents the consequences of adaptation of each plant species interacting with its environment over a period of time. Out of this assortment of diversity, few

selected species have undergone the process of domestication, whereby intense selection pressure was imposed for traits important to humans. While domestication brought about larger fruits, non-shattering grains, and higher harvest index, each species was constrained by the innate responses for dealing with various abiotic stresses. However natural and artificial selection still played a notable role during this domestication, particularly for adaptation to various environmental perturbations. At the same time, the production environment was altered to allow more stable crop production through land leveling, tillage, irrigation, weeding, soil amendments and mitigation strategies, designed to limit stress-induced yield losses. The fact that landraces of most crops are relatively tolerant to a wide array of abiotic stresses demonstrates the success of early plant selectors; however, it is due to recent advances in genetics and molecular biology technology that plant breeders have begun to develop new strategies for developing tolerant, high yielding varieties of various crops.

The ability of crop plants to succeed in stress-prone environments is becoming increasingly important with the need to

- Produce more food from marginal resources as a response to increasing human population pressure
- Allow crops to adjust to the adverse global climate changes

---

*Abbreviations:* AGI – *Arabidopsis* Genome Initiative; BAC – bacterial artificial chromosome; CSSLs – chromosomal segment substitution lines; EPSO – European Plant Science Organization; ERF – ethylene responsive factors; FNP – functional nucleotide polymorphism; HKT – transporters high-affinity K<sup>+</sup> transporter; IRGSP – International Rice Genome Sequencing Project; IRIS – International Rice Information System; LD – linkage disequilibrium; LOD – scores logarithm of the odds ratio; MABC – marker-assisted backcrossing; MAS – marker-assisted selection; NILs – near-isogenic lines; OsHKT8 – *Oryza sativa* cation transporter HKT8; PUP1 – phosphorus uptake 1; QTLs – quantitative trait loci; RFLPs – restriction fragment length polymorphism; RILs – recombinant inbred lines; ROS – reactive oxygen species; SOS – salt overly sensitive; SSR – simple sequence repeat; SNP – single nucleotide polymorphism; SKC1 – shoot potassium content 1; SUB1 – submergence 1

- Improve the lives of the poorest farmers who depend on stable yields in marginal environments
- Produce higher yields on shrinking resources such as water and agricultural lands, which are rapidly degrading

Fortunately, within major crop species, potential donors exist in the available germplasm pool for tolerance to most abiotic stresses, although with varying degrees of accessibility. Many traditional landraces have higher levels of adaptation to stresses as compared to modern high yielding varieties, but they also have many undesirable traits and lower yields. Wild crop relatives may even have higher tolerance, but also pose greater problems in their use for breeding. Plant breeders have faced difficulties in transferring abiotic stress tolerance from exotic germplasm because of negative linkage drag and also due to the polygenic nature of many abiotic stress tolerance traits. Furthermore, breeding programs need to take into account that crops often face multiple abiotic stresses over the course of a growing season, such as an early drought followed by flooding later in the season, and salinity stress followed by drought as in many coastal and inland areas. These stresses could even occur simultaneously, like P- and Zn-deficiencies and Fe- and Al-toxicities often found in acid and alkaline soils (Ismail et al. 2007). These challenges have forced breeders to search for innovative strategies to make further progress on the seemingly intractable problems that have continued to hinder conventional breeding efforts.

Recent advances in understanding the molecular mechanisms of abiotic stress responses, along with the breakthroughs in molecular marker technologies, have now enabled the dissection of complex traits underlying many types of stress tolerance in crop plants. The process of genetic linkage mapping as applied towards polygenic traits has led to the identification of quantitative trait loci (QTLs) that control complex traits in plants. Furthermore, by using natural genetic variation to investigate the elaborate systems plants have evolved to deal with a host of abiotic stresses, geneticists can now identify superior tolerance alleles and transfer these alleles into high yielding, stress sensitive varieties. These advances have paved the way towards a marker-assisted breeding approach that employs the latest

technologies to further improve the performance of varieties and elite breeding lines developed through conventional crossing. While transgenic technologies will ultimately play an important role in developing abiotic stress tolerant plants, a marker-assisted approach provides a useful alternative when the required traits are available within the species gene pool, and especially in situations where genetically modified organisms face difficulties in approval and are yet to be widely accepted.

In this chapter, we will cover the use of molecular markers as tools for dissecting the complex traits associated with tolerance of abiotic stresses in major crop plants through QTL mapping, gene discovery and marker-assisted selection (MAS). We will then provide several case studies of how these techniques are currently being employed in the case of rice, to enhance tolerance towards abiotic stresses, including salinity, flooding, phosphorus deficiency, and drought. Lastly, we will provide some thoughts on how future advances, such as bioinformatics and association genetics, might empower marker-assisted breeding techniques for developing high yielding, stress-tolerant varieties in a more efficient way.

## II Molecular Markers as Tools for Dissecting Quantitative Traits

Plant adaptation to variable environments is reflected by an interrelated set of complex physiological and morphological traits, each with an intricate regulatory system. By integrating physiological and genetic strategies, we can obtain a deeper understanding of the underlying molecular mechanisms, which opens the way towards a more targeted breeding approach for higher stress tolerance in crop plants. The breakthrough that has made this approach possible was the introduction of easy-to-use DNA markers that brought QTL mapping into the mainstream, making it possible to efficiently map the genetic loci controlling complex traits. This was made possible through genetic linkage analysis, allowing the construction of linkage maps, and the identification of QTLs controlling particular traits based on statistical methods that help establish the association between molecular markers and phenotypic data.



## A Dissecting Complex Traits Using QTL Mapping

Although the theoretical underpinnings of modern QTL mapping were introduced earlier in the twentieth century, the method was limited in application due to the dependence on morphological markers to tag genes (Sax 1923; Thoday 1961). It was not until the introduction of molecular markers, starting with isozymes, that QTL mapping could provide comprehensive coverage of the genome in scanning the loci that control complex traits (Tanksey 1993). Once DNA markers such as RFLPs and SSRs became widely available for most plant species, QTL mapping was quickly adopted. To date, there are over 10,000 mapped QTLs reported for rice and maize in the Gramene database ([www.gramene.org](http://www.gramene.org)). One of the key advantages of QTL mapping is the ability to map genes underlying many different traits and trait components using the same mapping population and the same genetic linkage map. For abiotic stress tolerance, it becomes possible to test different physiological components and compare the QTL locations for these with the QTLs for tolerance or yield under stress to identify the causal factors. Furthermore, use of permanent mapping populations, such as recombinant inbred lines (RILs) or chromosomal segment substitution lines (CSSLs) enables testing stress tolerant traits in replicated experiments across different environments, which can help differentiate the QTLs based on their effectiveness at different stress levels. Once important QTL targets are identified, i.e., large-effect QTLs from the donor that provide increased stress tolerance, these can be captured as single introgressions in a set of near-isogenic lines (NILs), which can help unravel the complexity of different traits by limiting the variation between lines to focus only on the locus of interest. The NILs then provide the foundation for further physiological characterization, fine-mapping, and ultimately cloning of the QTL to identify the causal gene.

## B Gene Discovery: Genomics and Positional Cloning

Not long after QTL mapping became commonplace, another breakthrough arrived that brought genetic mapping to the DNA sequence level, i.e.,

the first high-quality complete sequencing of a plant, *Arabidopsis* (*Arabidopsis* Genome Initiative 2000), which was followed soon after by the complete sequencing of rice (International Rice Genome Sequencing Project 2005). Having the complete DNA sequence was an instant boon to genetic mapping as it presented an opportunity to make a universal consensus map that can bring together genetic mapping data from disparate sources into a single physical map based on the DNA sequence. This eliminated problems with ambiguous marker orders and variable map distances, and allowed previously mapped genes, QTLs, and markers to be integrated regardless of the original mapping population. In addition, it provided many new markers across the genome, which is essential for fine-mapping. For example, the rice microsatellite map grew from 500 simple sequence repeat (SSR) markers using conventional techniques (Temnykh et al. 2001); to 2,740 SSRs using limited sequence data (McCouch et al. 2002); to 18,828 SSRs using the complete rice genome sequence (International Rice Genome Sequencing Project 2005). In the future, single nucleotide polymorphism (SNP) markers will further increase the number of available markers and will enable more cost-effective high-throughput genotyping techniques (Box 20.1). This wealth in the number of markers is also helpful when screening large numbers of background markers to offset low polymorphism rates, when dealing with closely related parents.

### Box 20.1 How Will New Marker Technologies Impact Marker-Assisted Breeding?

*Present Technology:* Currently, SSRs are predominantly being used to map and introgress agronomically important QTLs into popular varieties using MABC. However, their use is still limited by the lack of sufficient polymorphism particularly within related genotypes, labor requirements and cost of application. In addition, SSR markers have a low potential for multiplexing and require lengthy periods of time to genotype many markers (as during the initial background selection in the marker-assisted backcrossing protocol; see Fig. 1). This results in a short window of time available to obtain the necessary data to select which individuals to backcross.

**Box 20.1 (continued)**

*Future Technology:* New marker technologies, such as single nucleotide polymorphism (SNP) markers, promise to greatly increase the number of available markers and the speed of genotyping while lowering the cost per data point. For example, Illumina SNP-bead arrays can be used to simultaneously genotype 1,536 SNP markers across the genome for each DNA sample.

*Impact:* SNP markers will enable genome-wide screens of thousands of markers simultaneously, which will allow all donor introgressions to be quickly identified during the background selection steps in the marker-assisted backcrossing protocol (see Fig. 1). This information will allow more selective genotyping in subsequent steps, since only the known introgressions need to be tracked. Likewise, the high resolution SNP genome scans can be used for the final step to confirm the background conversion to the recurrent parent.

*Outlook:* As new marker technologies bring down the cost per data point, it makes more sense to integrate high resolution genome scans into marker-assisted breeding programs to increase the overall efficiency by reducing the time spent on marker genotyping and providing more robust data with fewer errors and more confidence in the location of the donor introgressions. These improvements will likely result in more effective use of markers in breeding for abiotic stress tolerance in major crop plants.

These advances have improved the efficiency of fine-mapping and have made cloning a QTL, to isolate the casual gene, much easier in *Ara-bidopsis* (Lukowitz et al. 2000; Jander et al. 2002) and in rice (Ashikari and Matsuoka 2006), in spite of the challenges still existing (Salvi and Tuberosa 2005). Most of the QTLs cloned to date were associated with morphological attributes such as plant height, fruit characteristics or flowering time (Paran and Zamir 2003), and similar approaches can be used successfully to identify genes controlling key steps for other physiological traits. Several major QTLs associated with tolerance of abiotic stresses have been identified and fine-mapped in rice, with the first examples of map-based cloning being the salinity

tolerance QTL *SKC1* (Ren et al. 2005) and the submergence tolerance QTL *SUB1* (Xu et al. 2006). The fine-mapping and cloning of QTLs has also given more confidence in the results of the primary QTL studies, which have proven to be highly accurate upon retrospect (Price 2006). Once a QTL is cloned, knowledge of the underlying sequence allows further probing into allelic variation at the causal gene level, which can help identify the functional nucleotide polymorphism (FNP) that controls the change in phenotype. The FNP can then be used to develop a functional or perfect marker that directly assesses the desired phenotype at the molecular level. For example, the cloning of the fragrance gene led to a perfect marker for aroma in rice at an 8 bp deletion (Bradbury et al. 2005), and the cloning of the gene for red pericarp in rice led to the identification of a 14 bp deletion that has been developed into a marker for red rice (Sweeney et al. 2006). These functional markers can have several advantages in marker-assisted breeding, especially as they will always co-segregate with the desired phenotype, eliminating the danger of recombination between the linked markers and the target gene. This also allows for rapid diagnosis of the allele state at that gene across diverse germplasm accessions (Andersen and Lubberstedt 2003; Mackill and McNally 2005). In a number of cases, however, the FNP may be elusive, especially if multiple sequence changes can result in the same phenotype. In this case, the FNP marker may work well with a particular source of the gene, but may not work across all germplasm accessions that have the trait.

**C Strategies for Marker-Assisted Selection**

The recent advances in genomics have paved the way for clear and reliable methods for MAS in plants: from QTL identification, NIL development and fine-mapping to transferring the QTL into popular varieties using a precise marker-assisted backcrossing (MABC) strategy (Mackill 2006; Collard et al. 2005; Collard and Mackill 2008; Collard et al. 2008). MABC involves the manipulation of genomic regions involved in the expression of particular traits of interest through DNA markers, and combines the power of a conventional backcrossing program with the ability to differentiate parental chromosomal segments.

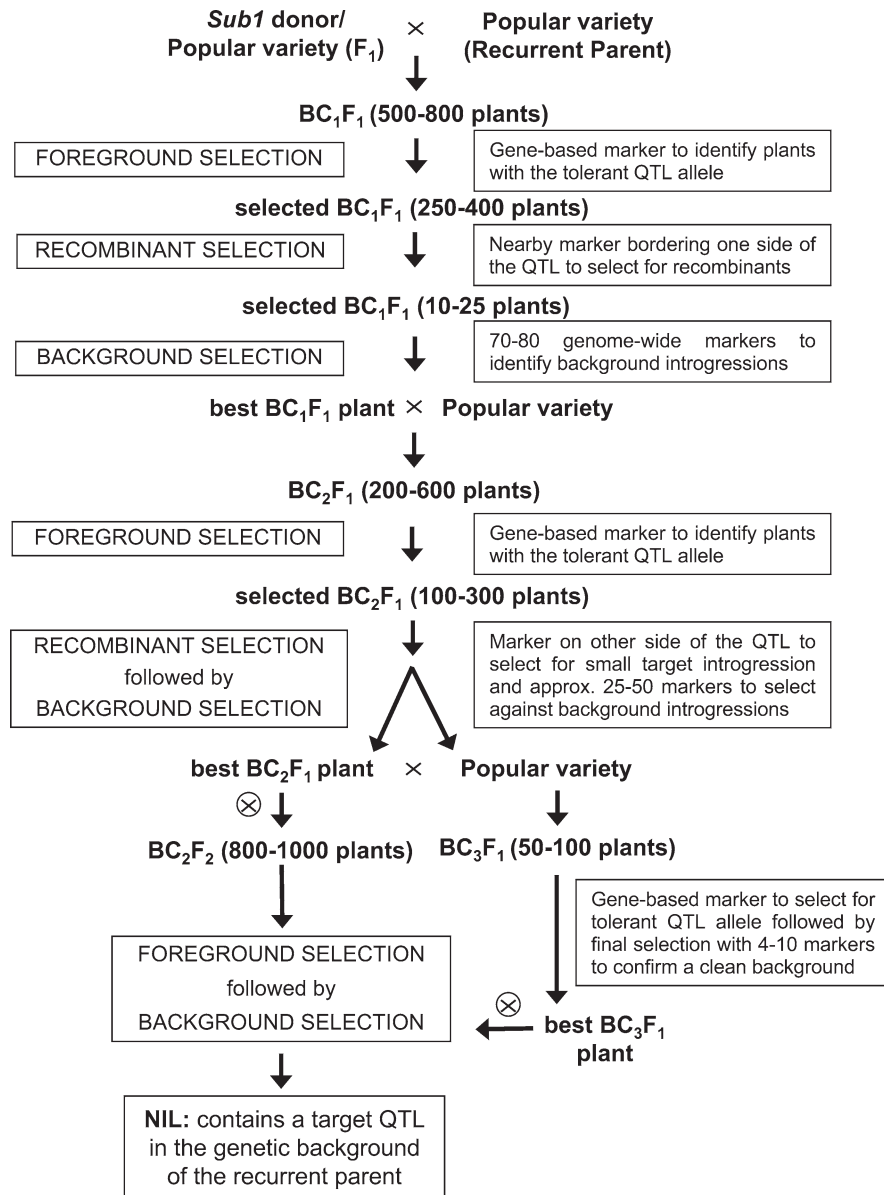

Fig. 1. Example of the marker-assisted backcrossing scheme used to transfer the *SUB1* QTL for submergence tolerance into six mega-varieties, showing recommended numbers of plants and markers for each step to develop a *Sub1*-converted near-isogenic line (NIL), at either the BC<sub>2</sub>F<sub>2</sub> or BC<sub>3</sub>F<sub>2</sub> generation, depending on the number of background introgressions remaining at the BC<sub>2</sub>F<sub>1</sub> generation and the size of the target introgression desired (Neeraja et al. 2007; E. Septiningsih, unpublished).

The efficiency of a MABC program depends on a number of factors, including the size and reliability of the target QTL effect, the precision of the target gene/QTL fine-map, the rate of polymorphism when identifying background markers, as well as the cost, speed, and failure rate of the markers employed in each customized MABC system. For each set of parents and for each target QTL, a cus-

tomized MABC package needs to be developed with optimized foreground markers to select the QTL target, recombinant markers flanking the locus of interest to reduce linkage drag and an evenly-spaced set of polymorphic background markers across the genome to select the recurrent parent background (Neeraja et al. 2007; Col-lard and Mackill 2008). QTL mapping has been

progressing at an accelerating pace over the past decade, but few products using this technology have been released to farmers. Constraints to the use of marker-assisted selection for quantitative traits include:

- Poor resolution of QTLs on the genetic map
- Small effects of many QTLs
- Interaction of QTLs with environment or genetic background
- Poor selection of appropriate parents for mapping populations
- The expense of genotyping, limiting the number of samples that can be processed

If these constraints are carefully addressed, breeders would be much more likely to use MABC to develop stress-tolerant varieties.

The proper selection of QTL targets, combined with the development of an optimized MABC package consisting of tested markers and appropriate donors, is essential for the successful implementation of MABC for any breeding targets. The selection of the QTL target and appraisal for its usefulness in a MABC program needs to weigh the benefits of a marker-assisted program versus conventional selection. For example, often trait components can be used directly for selection in plant breeding depending on their degree of association with plant adaptability or yield under specific environments, the cost and precision of their assessment and their interaction with the environment. The genetic control of these traits can be affected by factors such as the number of genes involved, extent of association with undesirable pleiotropic effects, or adverse genetic linkage. Traits such as yield, nutrient acquisition and tolerance of abiotic stresses consist of several underlying components that need to be combined to achieve higher performance. At present, inadequate progress has been made in using these physiological criteria for the large-scale breeding needed to combine multiple traits of importance, and their use has been essentially limited to the identification of parental lines. The value of using markers as a surrogate for direct selection of stress tolerance components or yield under stress will often depend on how difficult are the phenotyping techniques and the amount of replicated trials required versus how reliable are the linked markers in predicting the phenotype after its transfer to a recipient variety. Practically,

it is advisable to introgress QTLs of important agronomic or adaptive values into varieties that are well known to farmers and are covering large areas. This will ensure that the new varieties will be used immediately by farmers, millers and marketing channels, who are usually cautious when taking on new varieties (Mackill 2006). Provided that popular varieties normally have limited lifespan, MABC also needs to be integrated with conventional breeding to incorporate useful QTLs into elite breeding lines.

So far, the greatest success in MABC for improving tolerance of biotic and abiotic stresses has been achieved with QTLs proven to provide high levels of tolerance in many different genetic backgrounds and environments (Collard and Mackill 2008; Collard et al. 2008). A good example in cereals is the introgression of *SUB1*, the major QTL for submergence tolerance, into several popular rice varieties (Xu et al. 2006; Neeraja et al. 2007). Future breeding objectives, however, may require more complex situations, such as the pyramiding of multiple QTLs having more subtle effects that are effective during different developmental stages, or the combining of QTLs for different abiotic stress tolerance into the same genetic background. Up to now, MABC has been successful in transferring traits whose expression is controlled by a single gene or by a gene that controls most of the phenotypic variance of the trait. However, the effective use of MABC in combining several genomic regions which control a single trait or a few independent traits required for a desired phenotype still awaits further development of more efficient technologies and innovative strategies. An example of a successful approach used in the transfer of a single QTL into several popular rice varieties is presented in Fig. 1.

### III Case Studies from a Model Crop: MAS for Abiotic Stress Tolerance in Rice

Abiotic stresses seem to offer unique opportunities for the application of markers because of the identification of major QTLs coupled with the progress made in understanding the biology of tolerance to these stresses and the availability of efficient phenotyping systems, which hold promise for tackling such challenging traits. The most common stresses adversely affecting rice



production are excess or deficiency of water, extremes of temperature, and mineral deficiencies or toxicities. We will briefly review the progress made in several key stresses that limit rice production worldwide.

### A Flooding

Excess water stress is a serious problem for rice in flood-prone areas, with damage resulting from water logging during germination, and partial or even complete submergence for varying durations during the growing season. Various tolerance traits are necessary for high and stable productivity in these areas. Direct seeding of rice is increasingly being practiced in both rain-fed and irrigated areas because of labor shortage for transplanting. However, poor crop establishment remains a major obstacle facing its large-scale adoption in areas where flooding is anticipated due to rain or uneven leveling. Using a backcross population developed from a tolerant landrace “Khao Hlan On”, and a sensitive variety IR64, six QTLs were detected, two each on chromosomes 1, 7 and 9, explaining 7–31% of the phenotypic variation, and with LOD scores in the range of about 5–20 (Angaji et al. 2009). Current efforts focus on fine-mapping a few of these QTLs for exploitation through MABC (E. Septiningsih, unpublished).

Complete submergence affects more than 10 million hectares of rice lands in Asia. This stress received considerable attention in the past few decades, and a few tolerant landraces were identified that can withstand inundation for up to 2 weeks. The physiological bases of tolerance were also extensively studied, and among the traits identified (as critical for tolerance) are high energy reserves, limited underwater growth and retention of chlorophyll (Jackson and Ram 2003; Ella et al. 2003; Sarkar et al. 2006). The Indian cultivar FR13A is the most widely used source of submergence tolerance, and a major QTL, designated *SUB1*, was identified that controls most of the submergence tolerance of this genotype (Xu and Mackill 1996). FR13A also has additional QTLs that contribute to its tolerance (Nandi et al. 1997; Toojinda et al. 2003). *SUB1* was subsequently fine-mapped and cloned, and three genes encoding putative ethylene responsive factors (ERF), *SUB1A*, *SUB1B*, and *SUB1C*, were identified. *SUB1A* was recognized as the

primary contributor to submergence tolerance (Xu et al. 2006). Cloning of *SUB1* provided an excellent opportunity to gain a better understanding of the molecular mechanisms and to unravel the pathways underlying submergence tolerance, and it also helped in designing precise gene-based markers for more accurate genotyping. *SUB1* has been successfully introgressed through MABC into a popular high-yielding variety, *Swarna*, within a 2-year time frame (Neeraja et al. 2007). “Swarna-Sub1”, the first example of a submergence tolerant mega variety, is being evaluated in submergence-prone areas of India and Bangladesh. In the absence of submergence, there were no significant differences in agronomic performance, grain yield or quality between *Swarna* and *Swarna-Sub1* (Sarkar et al. 2006; Neeraja et al. 2007), but a substantial enhancement of survival (Fig. 2a) and two to three-fold increase in yield over the intolerant parent was observed after submergence for 12–17 day period during vegetative stage in the field (Singh et al. 2009). Due to its large effect in providing tolerance, this QTL is an excellent candidate for the application of MAS, and progress has been made to successfully convert several popular rice varieties to submergence tolerant varieties using marker-assisted backcrossing with *SUB1* (Septiningsih et al. 2009).

The *SUB1* QTL provides a marked improvement of submergence tolerance in all genetic backgrounds and environments tested so far. Yet, the level of tolerance is still below that of the original donor FR13A. There is a need to identify and combine additional genes from FR13A and probably from additional donors, including those that confer rapid recovery after submergence, along with *SUB1*. Varieties that combine tolerance to submergence during germination as well as the vegetative stage, together with tolerance to partial long-term stagnant flooding, would have a major advantage for achieving higher and more stable productivity in flood-prone areas. Molecular markers specific to *SUB1* and to QTLs associated with tolerance of anaerobic conditions during germination are currently being used to select new lines combining both traits.

### B Salinity

Salt stress negatively affects growth and productivity of most crop plants and recent research



*Fig. 2. (a)* Performance of *Sub1* introgression lines under field conditions. Fourteen day old seedlings were transplanted in the field and completely submerged 14 days later, for 17 days. Photo was taken about 2 months after desubmergence. (1) IR64, (2) IR64-Sub1, (3) Samba Mahshuri, (4) Samba Mahshuri-Sub1, (5) IR42 (sensitive check) and (6) IR49830 (tolerant, used as *SUB1* donor) (Photo courtesy of IRRI); *(b)* a rice farmer and his wife showing the performance of their local variety (*right*) and an improved salt tolerant breeding line (*left*) in a highly alkaline soil in Faizabad district, Uttar Pradesh, India (Photo by A. Ismail taken on Oct. 7, 2007) [See Color Plate 12, Fig. 19].

has started to unravel the complexities of the traits involved in its tolerance, such as control of sodium transport,  $\text{Na}^+$  and  $\text{K}^+$  ion homeostasis, and salt response signaling (Zhu 2003; Horie and Schroeder 2004). The fundamental knowledge of salt response mechanisms in plants forms the basis for developing strategies to improve salt tolerance in crop species such as rice (Sahi et al. 2006; Ismail et al. 2007). Although rice is relatively salt-sensitive, it is the only cereal that can grow on many salt-affected soils because it can survive recurrent floods in coastal areas and can thrive in standing water that can help leach salts from top soils in inlands. Tolerance of salt stress in rice is complex and varies with the stage of development, being relatively tolerant during germination, active tillering and towards matu-

rity, but sensitive during the early vegetative and reproductive stages (also see Chapter 18). Salinity tolerance at these two sensitive stages is only weakly associated (Moradi et al. 2003). Hence, discovering and combining suitable tolerance traits at both stages is essential for developing resilient salt-tolerant cultivars. Despite this complexity of traits associated with salinity tolerance in rice, substantial progress has been made in developing salt tolerant breeding lines that are being evaluated and selected in farmers fields (Fig. 2b), some of which have been also released as varieties.

Tolerance during the early vegetative stage involves a number of contributing traits, including salt exclusion and control of ion homeostasis, higher tissue tolerance by compartmentalizing

salt into vacuoles, responsive stomata that close faster upon exposure to salt stress, up-regulation of antioxidant systems for protection against reactive oxygen species (ROS) generated during stress, and vigorous growth to dilute salt concentration in plant tissue, amongst others (Yeo and Flowers 1986; Moradi and Ismail 2007). During the reproductive stage, tolerant genotypes tend to exclude salt from flag leaves and developing panicles (Yeo and Flowers 1986; Moradi et al. 2003). Developing tolerant varieties will entail combining these various component traits into a high yielding genetic background, which is hard to achieve through conventional methods. The recent advances in understanding the physiological and molecular bases of tolerance are providing better tools to overcome these hurdles and can substantially enhance progress by enabling more precise genetic manipulation.

Recently, sodium transporters have been shown to play key roles in maintaining ion homeostasis in plants under salt stress, through several mechanisms that remove sodium from the cytoplasm by either compartmentalizing it into vacuoles or extruding it out of the cell (Horie and Schroeder 2004). The salt overly sensitive (*SOS*) pathway is well characterized in *Arabidopsis* as being involved in signal perception and ion homeostasis under salt stress (Zhu 2003). Recently, the role of this system in controlling salt stress in case of rice has been further elucidated (Martinez-Atienza et al. 2007). *SOS* pathway genes have also been identified in *Brassica* (Kumar et al. 2009). In addition, the HKT family of transporters has been shown to play important roles in sodium and potassium uptake as well as homeostasis in a number of plant species including rice (Horie et al. 2001; Gollack et al. 2002). Recently, cloning of the rice QTL *SKCI*, originally detected by its effect on  $K^+$  concentration, identified the causal gene as the sodium transporter *OsHKT8* (Ren et al. 2005).

Several mapping studies identified QTLs associated with salinity tolerance in rice. For example, a study employing the tolerant *Indica* landrace *Nona Bokra* with the susceptible japonica Koshihikari, identified several large-effect QTLs, including the *SKCI* QTL and a QTL for shoot  $Na^+$  concentration on chromosome 7 (Lin et al. 2004). Similarly, a RIL population between the highly tolerant landrace *Pokkali* and sensitive IR29 identified a major QTL, designated *Saltol*, on chromosome 1, which accounts for about 45%

of the variation for seedling and shoot  $Na^+/K^+$  ratio (Bonilla et al. 2002). While the salt-tolerant landraces *Pokkali* and *Nona Bokra* were routinely used in the past for breeding, the level of tolerance attained by new lines is always below that of the traditional donors (Gregorio et al. 2002), and the existing tolerant varieties seem to be superior in only a few of the traits known to be associated with tolerance. Combining superior alleles underlying these traits could potentially result in higher levels of tolerance, a task difficult to achieve through conventional methods. More recently, the application of QTL mapping provided the means to genetically dissect tolerance traits into discrete QTLs that can then be pyramided into high-yielding rice varieties using DNA markers. By integrating physiological trait dissection with these genetic and genomic tools, a more complete picture of the complex mechanisms of salt tolerance in rice is beginning to emerge. These advances in turn provide the foundation for efficient deployment of tolerance QTLs through MAS.

Near-isogenic lines have been developed for *Saltol*, which is the major QTL on chromosome 1. The locus is currently being fine-mapped and annotated for further candidate gene analysis and more precise gene-specific markers are being developed. A MABC strategy for *Saltol* was developed and is currently being used to incorporate the *Pokkali* allele into popular salt stress-sensitive varieties. Furthermore, other QTLs were identified on chromosomes 3, 4, 10 and 12 for salinity tolerance at the seedling stage. Genetic stocks of RILs and backcross populations were developed to allow further analysis of these QTLs to evaluate their usefulness in breeding. Mapping populations are being developed to identify QTLs associated with tolerance during the reproductive stage, to ultimately combine tolerance at both stages for more stable performance in salt affected areas. After identifying a number of QTLs controlling different mechanisms and providing tolerance at different stages, MABC can be used to develop rice varieties adapted to any specific target conditions based on the extent and time of stress, during the season when stress is anticipated.

### C Phosphorus Deficiency

After nitrogen, phosphorus is the most important inorganic plant nutrient but the least available in most soils because of its tendency for tight



binding. As a consequence, phosphorus deficiency is widespread in many rice-growing areas, particularly where farmers do not have access to phosphate fertilizers and, in most cases, because these soils have high P-fixing capacity. Breeding efficient cultivars capable of effectively mining the large pool of P already fixed in most soils will help increase and sustain yields in low-input agricultural systems, particularly for cereal crops.

Two QTL mapping studies have been reported in rice. Wissuwa et al. (1998) used a backcross inbred population, with the recurrent parent *Nipponbare* (*japonica*, sensitive) and the landrace Kasalath (*indica*, tolerant). They detected a major QTL on chromosome 12 for P uptake, P-use efficiency, shoot dry weight, and tiller number. For P uptake, this QTL had a LOD score of 10.7 and explained about 28% of the phenotypic variation. Ni et al. (1998), using RILs from the cross of IR20 (tolerant) with IR55178-3B-9-3 (sensitive), found a similarly strong QTL in the same location. They measured P uptake efficiency as relative tillering ability, relative shoot dry weight, and relative root dry weight. Moreover, an intermediate QTL on chromosome 6 and several other minor QTLs were mapped to several chromosomes. The QTL on chromosome 6 accounted for 25–34% of the variance for the above traits in the Ni et al. (1998) study, but has much less effect ( $R^2 = 9.8\%$ ) in the field study of Wissuwa et al. (1998). Subsequent studies focused on the major QTL for phosphorus uptake, located on chromosome 12, designated “*PUP1*”. Wissuwa and Ae (2001a) transferred this QTL by three backcrosses into the *japonica* variety Nipponbare. The resulting lines containing the tolerant allele showed a 170% increase in P uptake and 250% increase in yield when grown under low-P conditions. The NILs with the *PUP1* allele from Kasalath had increased root growth under low-P conditions, but the differences in root growth and P uptake were not observed under anaerobic soil conditions (Wissuwa and Ae 2001b). This QTL explained close to 80% of the phenotypic variation in a secondary mapping population (Wissuwa et al. 2002). Additional cycles of fine mapping further reduced the *PUP1* interval to about 145 kb (Heuer et al. 2009). Subsequent sequencing of the corresponding chromosomal region in the donor parent “Kasalath” showed that *PUP1* locus in Kasalath is much larger (278 kb), with large numbers of transposon- and retro-transposon-related

elements (Heuer et al. 2009). None of the genes annotated in the *PUP1* locus were found to be related to previously known genes involved in P uptake or metabolism, and detailed analyses of the putative candidate genes are currently ongoing. A marker assisted backcrossing system was developed and is being used to transfer this QTL into three popular upland rice varieties that were sensitive to phosphorus deficiency, particularly in acid soils (A. Ismail, M. Wissuwa, S. Heuer, unpublished). The significance of this QTL in enhancing P-uptake efficiency will further be validated after completing the development of these near isogenic lines.

### D Drought

Drought is the most widespread and damaging of abiotic stresses, but improving the drought tolerance of rice has been hindered by the low level of genetic variability and the complex inheritance of the trait. One of the most serious constraints to improving drought tolerance is the difficulty of accurately measuring the level of tolerance. Stress symptoms such as leaf death and rolling are the easiest to measure, but these traits are not always related to yield under stress or to yield in the target environment, which would include yield under stress as well as yield potential without stress. Molecular approaches to drought tolerance have been widely applied to rice, beginning with QTL analysis. Numerous QTLs were identified for secondary traits that are expected to be associated with drought response, such as root characteristics (depth, volume, thinness, penetration ability), leaf rolling and death, membrane stability, and osmotic adjustment (Lafitte et al. 2006). However, very few studies have mapped QTLs related to the actual objective of enhanced yield under drought.

Babu et al. (2003) found important QTLs related to grain yield under stress on chromosomes 4 and 12. More recently, two major QTLs for yield under drought were mapped. Bernier et al. (2007) identified a major QTL (*qt12.1*) for drought tolerance in a Vandana × Way Rarem mapping population. This QTL improves yield under drought by 47%, and explained more than 50% of the genetic variance. Furthermore, this QTL co-localized with *PUP1*, the P uptake QTL on chromosome 12. Fine-mapping of this locus is currently ongoing to establish whether the drought QTL is



pleiotropic with *PUP1* or whether the two are just closely linked. Understanding this association is important because the *PUP1* locus was found to enhance root growth and is effective only in aerobic soils. A second major QTL was mapped on chromosome 4 from an IR55419-04 (tolerant) × Way Rarem mapping population (A. Kumar et al., unpublished). This QTL is currently being fine mapped at IRRI. Both QTLs hold greater promise as targets for marker-assisted breeding to enhance drought tolerance in rice.

## IV Future Perspectives

### A Association Mapping for Abiotic Stress Tolerance

Association or linkage disequilibrium (LD) mapping represents an alternative approach to identifying genes or genomic regions associated with quantitative phenotypic variation (Buckler and Thornsberry 2002; Gupta et al. 2005). Similar to QTL mapping, association mapping exploits natural diversity and recombination within a population to correlate polymorphisms with measurable phenotypic variations. However, in contrast to linkage or QTL mapping, which depends on recombination events generated over a fixed number of generations following a bi-parental cross, association mapping exploits larger number of historical recombination events in a population or diverse set of lines over the course of evolution.

Linkage disequilibrium mapping has several advantages over traditional QTL mapping approaches (Thornsberry et al. 2001). First, it can survey the range of allelic variation present in a natural population, and is not restricted to a set of alleles found in the two progenitors of a mapping population. Second, by relying on historical recombination, it is often possible to localize QTLs in a genome to a higher degree of resolution than is possible with the same number of individuals using traditional QTL linkage analysis. Third, the technique can be used without developing new mapping populations. Thus, LD mapping can potentially achieve higher resolutions with greater efficiency than linkage-based QTL mapping techniques by taking advantage of both the array of molecular diversity within a species and the large amounts of historical recombina-

tion that has occurred within and between populations during evolution. It is these features that have convinced geneticists and breeders to focus attention on LD mapping as an efficient strategy for identifying genes associated with traits of interest, including abiotic stress resistance, based on an exploration of the rich collection of rice genetic resources.

To undertake an association mapping experiment, a collection of accessions is genotyped for markers that span either the entire genome, or a genomic region of interest (Wilson et al. 2004; Szalma et al. 2005). The markers are then tested against a specific phenotype to determine whether a statistical correlation exists between marker genotypes and a particular trait. A significant association between marker(s) and trait may arise either because the nucleotide polymorphism causes the phenotypic difference, or because the marker is in LD with the causal or functional polymorphism (Thornsberry et al. 2001).

The resolution of an association mapping experiment depends on the extent of LD, which is the correlation between polymorphic loci within the test population (Flint-Garcia et al. 2003). When a mutation arises in a population, it is automatically associated or comes in “disequilibrium” with all the alleles present in the genome of the individual that gave rise to the mutation. If the mutation persists during evolution, associations with other alleles are gradually eroded by segregation and recombination, so that over a period of time, the mutation remains in LD only with alleles which are closely-linked to it physically (Hartl and Clark 1997).

The distance over which LD persists in a species or population determines the number and density of markers required for association mapping, with large variations observed both within and between genomes. The first study on LD in rice reported an LD decay of ~70 to 100 kb around the bacterial blight resistance locus, *xa5*, in the *aus* sub-population (Garris et al. 2003). More recent studies confirmed that LD generally decays at the rate of ~50 to 100 kb in landraces of *indica*, while it decays more slowly in *japonica* (~150 kb in *tropical japonica* and >500 kb in *temperate japonica*; Mather et al. 2007; Rakshit et al. 2007). LD generally extends over significantly larger distances in elite varieties than in landraces (Morrell et al. 2005; Remington et al.

2001; Tenaillon et al. 2001) due to inbreeding, selection, bottlenecks and population admixtures (Nordborg and Tavare 2002; Weir 1996).

The different rates of LD decay in different sub-populations of rice offer opportunities to consciously move between low and high-resolution mapping. In the first instance, the use of breeding lines and elite varieties with extensive LD means that a modest number of markers would be sufficient to identify region(s) of the genome containing a gene or QTL (Agrama et al. 2007; Zhang et al. 2005). While the LD mapping resolution using elite germplasm may not be significantly better than QTL mapping, it does, nonetheless, provide an opportunity to identify associations between a phenotype and a larger set of alleles. In contrast, the use of wild species or landrace varieties that exhibit more rapid LD decay require a larger number of markers to define the recombination profiles of the accessions and provide significantly higher LD mapping resolution. In cases where LD decay is very rapid it may not be cost-effective to saturate the entire genome with closely linked markers. In these situations, markers are targeted to a candidate gene or QTL region across the association mapping panel in an effort to narrow down the interval containing the target gene(s) (Garris et al. 2003; Kruglyak 1999; Olsen et al. 2006; Sweeney et al. 2007).

Association mapping is most productive when used in association with QTL mapping. Together, these approaches provide rice researchers with numerous possibilities for establishing meaningful associations between phenotypes and genes. There are currently efforts underway to develop a group of recombinant inbred populations for QTL analysis, along with an immortal association mapping panel that will offer the genetics and breeding community many opportunities to explore genetic diversity and the basis of phenotypic variation in rice. The association mapping panel will consist of several thousand diverse, purified genetic stocks of wild, landrace and elite rice accessions, and this collection can be expanded at will. Purification of the lines is required to ensure good quality and reproducibility of the genotyping and phenotyping effort that provides the data for association analysis. Use of genetically identical material will enable the rice research community to leverage its collective strengths to phenotype the lines in a distributed

manner, focusing on specific sub-populations and traits that are most interesting or important to a given group of researchers in different institutions and environments. The lines will be genotyped in a central facility and both the genotypic data and the purified seed stocks will be made publicly available. Using this coordinated approach, abiotic stress tolerance can be rigorously evaluated on a common set of materials over years and environments, and data collected by different groups of researchers can be analyzed together. This would provide new opportunities to unravel the relationship between genotype and phenotype, and will deepen our understanding of the diverse genetic mechanisms that allow plants to respond to a wide range of environmental stresses.

Based on estimates of LD, it is suggested that polymorphic markers will be needed approximately every 50 kb to cover the genome for association mapping in *O. sativa*. If this is true, then ~8,000 well-distributed polymorphic markers would provide a good chance of performing genome-wide association mapping in case of *O. sativa*. However, to have a reasonable chance of finding polymorphic markers across the different subpopulations, and to take advantage of the more rapid LD decay in some regions of the genome, it is recommended that a set of ~24,000 to 40,000 well-distributed markers be developed for association mapping in rice. A fixed genotyping array consisting of 44,100 SNP markers is currently under development for rice ([www.ricediversity.org](http://www.ricediversity.org)).

### *B Variety Development and Gene Deployment*

As plant breeders have achieved great success in developing high-yielding varieties, it has become increasingly difficult to significantly improve on these varieties for the basic agronomic traits of interest. Mega varieties that are widely grown and liked by farmers have been ensconced in the agricultural system and it is increasingly difficult to displace them due to their suite of desirable features. These varieties not only have high grain yield, but often have improved quality traits meaning that they can be easily sold and marketed, ensuring farmers of consistent demand. Furthermore, the seed systems in rice-growing countries cannot easily cope with multiple varieties

and this means that only one or a few varieties are easily available to the farmers. This situation explains why the varietal upgrade path through marker-assisted backcrossing is a reasonable one that is likely to achieve more impact through rapid adoption of improved varieties.

As discussed above, this approach is most effective when major QTLs are available for the traits of interest, and this has been the case for several abiotic stresses. Nevertheless a similar approach could be feasible for smaller QTLs. Even a relatively small-effect QTL could have a big impact if deployed over a large area. One of the advantages of the MABC approach is that linkage drag can be minimized through the use of recombinant selection with flanking markers (Collard and Mackill 2008). When multiple QTLs are being transferred, this could make a substantial difference in the ability to retain the desirable features of the mega variety. A wider use of this strategy by rice breeders underlines the importance for fine-scale mapping and positional cloning of QTLs. The wide applicability of this approach should not be seen as a substitute for more conventional breeding approaches that place emphasis on developing new mega varieties. The MABC strategy is a relatively conservative approach aimed at getting incremental improvements in the best varieties, while plant breeders will continue to aim at the goal of new mega varieties through multiple approaches relying on conventional breeding and MAS.

### *C Bioinformatics Supporting Molecular Breeding*

#### *1 Integrating Marker Genotype and Plant Phenotype Data*

Over 8,000 QTLs for a wide array of traits have been reported in rice over the last 15 years. Today, a coordinated body of information about the genomic location of these QTLs, as well as marker trait associations is available in the Gramene database ([www.gramene.org](http://www.gramene.org)). This information resource added value to individual mapping studies by aligning all the QTLs to the rice genome sequence using sequenced markers as anchors. As a result, the rice research community can now readily access information about linkage relationships among QTLs for different

traits, derive hypotheses about the stability of QTLs across genetic backgrounds and environments based on co-localization of QTLs across studies, and rapidly identify numerous sources of favorable alleles for diverse traits. The alignment of QTLs across multiple studies has also facilitated the effort to fine-map and clone genes underlying many of these QTLs, providing plant breeders with “functional markers” for use in MAS, and providing geneticists with new information about the genes and alleles that are critical to agricultural performance.

As agronomically useful genes are identified, they can be mapped to biochemical and regulatory pathways (Shimizu et al. 2007). Pathway information helps researchers to predict how variation at a particular locus may affect or be affected by other genes in the same or different pathways (European-Plant-Science-Organization 2005). It offers a framework for understanding epistasis, and can help identify multiple genetic factors that collectively determine the phenotype of a plant. It also provides opportunities to implement a reverse genetics approach for finding new genes associated with a trait of interest, and for helping to identify parents that may contribute useful variation to a breeding program.

#### *2 Using a Gene and Plant Ontology*

The rapid accumulation of genetic and genomic information today has led to a rapid change in our understanding of the biological world. We must scramble to identify and make use of relevant findings. Despite the abundance of new discoveries, we are challenged to find an appropriate method for screening through the mountain of data to identify meaningful bits of information. Genome databases are designed to address this problem by providing a set of tools for data browsing and data mining that are tailored according to the needs of the biological community. While not specifically designed for plant breeders, these databases are indispensable to the modern plant breeding community because they provide information about genes, alleles, germplasm, pathways, phenotypes and environments (Bruskiewich et al. 2003; Jaiswal et al. 2006b).

To be useful, data must be entered into the database in a timely way, and it must be structured and organized so that disparate pieces of

information can be retrieved computationally to answer a relevant question. Underlying the success of data mining activities is the use of ontologies and controlled vocabularies (sets of terms with defined relationships to each other), that provide a structured set of hierarchical relationships allowing independent pieces of information to be associated with each other in meaningful ways. In the context of genetics and plant breeding, ontologies have been developed for genes, phenotypes, traits, environments, etc. (Clark et al. 2005; Ilic et al. 2007; Jaiswal et al. 2006a; Pujar et al. 2006). These ontologies make it possible to compare data from diverse organisms and experiments within a data domain (i.e., genes), and they also make it possible for the computer to identify meaningful associations between data domains based on the relationships defined by the ontologies (i.e., genes and phenotypes).

The development of ontologies and controlled vocabularies is a rapidly evolving science. It represents a cross-road of expertise involving biologists, agriculturalists, computer scientists and software engineers, whereby essential biological relationships are examined and described in a clear and logical manner. In the Gramene database, several ontologies are currently employed to facilitate browsing and data mining activities, including the gene ontology, the plant anatomy ontology, the plant growth stage ontology, the trait ontology and the environment ontology (Clark et al. 2005; Ilic et al. 2007; Jaiswal et al. 2006b; Pujar et al. 2006; www.gramene.org). Use of these ontologies requires that data, or biological observations, be catalogued using structured as well as controlled vocabularies. The use of controlled vocabularies means that scientists are offered a menu of terms that can be used to describe or annotate observations and they have to choose from among these terms, rather than entering free text at the time of entering data into a database. The terms are defined in ways that allow a computer to recognize and rapidly retrieve them when queried to do so (Bruskiewich et al. 2003; Jaiswal et al. 2006b). The use of controlled vocabularies is necessary so that new observations can be readily placed into appropriate relationships with existing data by a computer and it subsequently facilitates retrieval of a meaningful set of related data points when prompted by a query.

### 3 Databases for the Next Generation of Plant Breeders

Because of their power and utility, genome databases have become part of the essential toolkit of modern plant breeders and geneticists. Not only do databases make it possible to identify candidate genes associated with phenotypes of interest, or to identify markers linked to a particular QTL for use in MAS, but they efficiently leverage information from an experiment conducted on one genome or in one environment as the basis for predicting relationships between traits, genes and pathways in another genome evaluated in a different environment. The role of comparative genomics and comparative biology as a paradigm for addressing questions of basic biological significance has begun to impact the applied plant breeding community as well. Questions that were once debated with species-specific and regionally localized communities are now addressed in a much broader, comparative context, and the perspective of many plant breeders has been transformed by the recent availability of relevant genome data and the power of genome databases and data mining tools to retrieve and assemble meaningful information in real time.

Nonetheless, there is still a gap between our ability to generate digital information about genes and alleles and corresponding phenotypic variation of interest, and a plant breeder's ability to utilize that information to develop a new variety. More emphasis needs to be placed on characterizing diverse genetic resources, both genotypically and phenotypically, and high throughput phenotyping methodologies are needed to keep pace with the flow of information from genome sequencing centers. Most importantly, we need greater integration between databases that specialize in germplasm information management and those that specialize in the management of gene-based knowledge. It is at the intersection of these two worlds where the greatest gain for plant breeders will lie, and where some of the most exciting scientific questions remain to be explored.

## V Conclusions

For rice, some of the best QTLs identified for abiotic stress tolerance have significantly larger



effects than those identified for yield and related agronomic traits (Mackill 2006). This suggests that measurable progress in improving productivity under unfavorable conditions could be achieved by transferring these loci into elite genotypes. QTLs that have a large effect on the phenotype and are relatively stable across genetic backgrounds and environments are most desirable for applications in marker-assisted selection. These QTLs could also aid in further dissection of the physiological basis of tolerance of these stresses. Isogenic lines that differ in the introgression of a particular QTL could be generated to help in functional analysis and in evaluating the effect of a particular QTL for yield improvement or for general adaptability.

The past two decades witnessed substantial progress in our understanding of plant functions and plant adaptations to different environments. This knowledge was aided by the integration of new tools of molecular biology with the conventional phenotypic methods of plant physiology and biochemistry. Most of the abiotic stress genes in case of rice have been detected based on visual symptoms and while these symptoms correspond fairly well to the actual damage that is observed under field conditions, more quantitative estimates of plant stress tolerance are needed. While phenotyping methodologies have not yet been automated, genotyping platforms are becoming increasingly automated, efficient and cost effective. This makes it possible for plant physiologists to dissect complex phenotypes into distinct factors that are associated with genetic loci or QTLs. The phenotypic impact of each QTL can subsequently be studied in specific genetic backgrounds by developing NILs for the locus under investigation. The ability to map QTLs also provides information about the association between physiological traits, particularly those that are inter-dependent, as well as in understanding the relationships of physiological and metabolic processes with other developmental and morphological traits. Molecular marker technology has greatly accelerated the progress in gene discovery through map-based cloning. The progress in understanding gene function will further be aided by expression analysis and evolutionary studies. Complementing conventional methods of plant breeding with MAS for favorable genes and QTL has already enhanced our breeding efficiency.

Indeed, it is an exciting era for plant breeders and physiologists who can bring new knowledge and technologies to bear on the development of more productive, stress-tolerant varieties as we strive to tackle the diverse challenges facing agriculture in the future.

## Acknowledgements

We gratefully thank E. Septiningsih and A. Kumar for sharing unpublished data. Research activities summarized here were supported in part, by the German Federal Ministry for Economic Cooperation and Development (BMZ), the CGIAR Generation Challenge Program, the Bill and Melinda Gates Foundation, and the International Rice Research Institute.

## References

- Agrama HA, Eizenga GC, Yan W (2007) Association mapping of yield and its components in rice cultivars. *Mol Breed* 19:341–356
- Andersen JR, Lubberstedt T (2003) Functional markers in plants. *Trends Plant Sci* 8:554–560
- Angaji SA, Septiningsih E, Mackill DJ, Ismail AM (2009) QTLs associated with tolerance of flooding during germination in rice (*Oryza sativa* L.). *Euphytica*, DOI 10.1007/s10681-009-0014-5
- Arabidopsis Genome Initiative (2000) Analysis of the genome sequence of the flowering plant *Arabidopsis thaliana*. *Nature* 408:796–815
- Ashikari M, Matsuoka M (2006) Identification, isolation and pyramiding of quantitative trait loci for rice breeding. *Trends Plant Sci* 11:344–350
- Babu RC, Nguyen BD, Chamarek V, Shanmugasundaram P, Chezian P, Jeyaprakash P, Ganesh SK, Palchamy A, Sadasivam S, Sarkarung S, Wade LJ, Nguyen HT (2003) Genetic analysis of drought resistance in rice by molecular markers: association between secondary traits and field performance. *Crop Sci* 43:1457–1469
- Bernier J, Kumar A, Ramaiah V, Spaner D, Atlin G (2007) A large-effect QTL for grain yield under reproductive-stage drought stress in upland rice. *Crop Sci* 47:507–518
- Bonilla P, Dvorak J, Mackill DJ, Deal K, Gregorio GB (2002) RFLP and SSLP mapping of salinity tolerance genes in chromosome 1 of rice (*Oryza sativa* L.) using recombinant inbred lines. *Philipp Agric Sci* 85:68–76
- Bradbury LMT, Henry RJ, Jin Q, Reinke RF, Waters DLE (2005) A perfect marker for fragrance genotyping in rice. *Mol Breed* 16:279–283

- Bruskiewich RM, Cosico AB, Eusebio W, Portugal AM, Ramos LM, Reyes MT, Sallan MA, Ulat VJ, Wang X, McNally KL, Sackville Hamilton R, McLaren CG (2003) Linking genotype to phenotype: The International Rice Information System (IRIS). *Bioinformatics* 19(Suppl 1): 63–65
- Clark JI, Brooksbank C, Lomax J (2005) It's all GO for plant scientists. *Plant Physiol* 138:1268–1279
- Buckler ES IV, Thornsberry JM (2002) Plant molecular diversity and applications to genomics. *Curr Opin Plant Biol* 5:107–111
- Collard BCY, Mackill DJ (2008) Marker assisted selection: an approach for precision plant breeding in the twenty-first century. *Phil Trans R Soc Lond B Biol Sci* 363: 557–572
- Collard BCY, Jahufer MZZ, Brouwer JB, Pang ECK (2005) An introduction to markers, quantitative trait loci (QTL) mapping and marker-assisted selection for crop improvement: the basic concepts. *Euphytica* 142:169–196
- Collard BCY, Vera Cruz CM, McNally KL, Virk PS, Mackill DJ (2008) Rice molecular breeding laboratories in the genomics era: current status and future considerations. *Int J Plant Genomics* p 25, doi: 10.1155/2008/524847
- Ella E, Kawano N, Yamauchi Y, Tanaka K, Ismail AM (2003) Blocking ethylene perception enhances flooding tolerance in rice seedlings. *Funct Plant Biol* 30:813–819
- European-Plant-Science-Organization (EPSO) (2005) European plant science: a field of opportunities. *J Exp Bot* 56:1699–1709
- Flint-Garcia SA, Thornsberry JM, Buckler IV ES (2003) Structure of linkage disequilibrium in plants. *Annu Rev Plant Biol* 54:357–374
- Garris A, McCouch S, Kresovich S (2003) Population structure and its effect on haplotype diversity and linkage disequilibrium surrounding the *xa5* locus of rice (*Oryza sativa* L.). *Genetics* 165:759–769
- Golladack D, Su H, Quigley F, Kamasani UR, Muñoz-Garay C, Bladeras E, Popova OV, Bennett J, Bohnert HJ, Pantoja O (2002) Characterization of a HKT-type transporter in rice as a general alkali cation transporter. *Plant J* 31: 529–542
- Gregorio GB, Senadhira D, Mendoza RD, Manigbas NL, Roxas JP, Guerta CQ (2002) Progress in breeding for salinity tolerance and associated abiotic stresses in rice. *Field Crops Res* 76:91–101
- Gupta PK, Rustgi S, Kulwal PL (2005) Linkage disequilibrium and association studies in higher plants: present status and future prospects. *Plant Mol Biol* 57:461–485
- Hartl DL, Clark AG (1997) Principles of population genetics. Sinauer Associates, Sunderland, MA
- Heuer S, Lu X, Chin J-H, Tanaka JP, Kanamori H, Matsumoto T, De Leon T, Ulat VJ, Ismail AM, Wissuwa M (2009) Comparative sequence analysis of the major quantitative trait locus phosphorus uptake 1 (Pup1) reveal a complex genetic structure. *Plant Biotech J* 7:456–471
- Horie T, Schroeder JI (2004) Sodium transporters in plants: diverse genes and physiological functions. *Plant Physiol* 136:2457–2462
- Horie T, Yoshida K, Nakayama H, Ymada K, Oiki S, Shinmyo A (2001) Two types of HKT transporters with different properties of Na<sup>+</sup> and K<sup>+</sup> transport in *Oryza sativa*. *Plant J* 27:115–128
- Ilic K, Kellogg EA, Jaiswal P, Zapata F, Stevens PF, Vincent LP, Avraham S, Reiser L, Pujar A, Sachs MM, Whitman NT, McCouch SR, Schaeffer ML, Ware DH, Stein LD, Rhee SY (2007) The plant structure ontology, a unified vocabulary of anatomy and morphology of a flowering plant. *Plant Physiol* 143:587–599
- International Rice Genome Sequencing Project (2005) The map-based sequence of the rice genome. *Nature* 436: 793–800
- Ismail AM, Heuer S, Thomson MJ, Wissuwa M (2007) Genetic and genomic approaches to develop rice germplasm for problem soils. *Plant Mol Biol* 65:547–570
- Jackson MB, Ram PC (2003) Physiological and molecular basis of susceptibility and tolerance of rice plants to complete submergence. *Ann Bot* 91:227–241
- Jaiswal P, Avraham S, Ilic K, Kellogg E, McCouch S, Pujar A, Reiser L, Rhee S, Sachs M, Schaeffer M, Stein L, Stevens P, Leszek V, Ware D, Zapata F (2006a) Plant ontology (PO): a controlled vocabulary of plant structures and growth stages. *Comp Func Gen* 6:388–397
- Jaiswal P, Ni J, Yap I, Ware D, Spooner W, Youens-Clark K, Ren L, Liang C, Zhao W, Ratnapu K, Faga B, Canaran P, Fogleman M, Hebbard C, Avraham S, Schmidt S, Casstevens T, Buckler E, Stein L, McCouch S (2006b) Gramene: a bird's eye view. *Nucleic Acids Res* 34:D717–D723; doi: 10.1093/nar/gkj154
- Jander G, Norris SR, Rounsley SD, Bush DF, Levin IM, Last RL (2002) *Arabidopsis* map-based cloning in the post-genome era. *Plant Physiol* 129:440–450
- Kruglyak L (1999) Prospects for whole-genome linkage disequilibrium mapping of common disease genes. *Nat Genet* 22:139–144
- Kumar G, Purty RS, Sharma MP, Singla-Pareek SL, Pareek A (2009) Physiological responses among Brassica species under salinity stress show strong correlation with transcript abundance for SOS pathway-related genes. *J Plant Physiol* 166:507–520
- Lafitte HR, Ismail AM, Bennett J (2006) Abiotic stress tolerance in tropical rice: progress and future prospects. *Oryza* 43:171–186
- Lin HX, Zhu MZ, Yano M, Gao JP, Liang ZW, Su WA, Hu XH, Ren ZH, Chao DY (2004) QTLs for Na<sup>+</sup> and K<sup>+</sup> uptake of the shoots and roots controlling rice salt tolerance. *Theor Appl Genet* 108:253–260
- Lukowitz W, Gillmor CS, Scheible WR (2000) Positional cloning in *Arabidopsis*. Why it feels good to have a genome initiative working for you? *Plant Physiol* 123:795–805
- Martinez-Atienza J, Jiang X, Garciadablas B, Mendoza I, Zhu JK, Pardo JM, Quintero FJ (2007) Conservation of

- the salt overly sensitive pathway in rice. *Plant Physiol* 143:1001–1012
- Mather KA, Caicedo AL, Polato NR, Olsen KM, McCouch SR, Purugganan MD (2007) The extent of linkage disequilibrium in rice (*Oryza sativa* L.). *Genetics* 177:2223–2232
- McCouch SR, Teytelman L, Xu Y, Lobos KB, Clare K, Walton M, Fu B, Maghirang R, Li Z, Zing Y, Zhang Q, Kono I, Yano M, Fjellstrom R, DeClerck G, Schneider D, Cartinhour S, Ware D, Stein L (2002) Development and mapping of 2240 new SSR markers for rice (*Oryza sativa* L.). *DNA Res* 9:199–207
- Mackill DJ (2006) Breeding for resistance to abiotic stresses in rice: the value of quantitative trait loci. In: Lamkey KR and Lee M (eds) *Plant breeding: the Arnel R. Hallauer International Symposium*. Blackwell, Ames, IA, pp 201–212
- Mackill DJ, McNally KL (2005) Molecular markers in rice: a model crop species. In: Lörz H, Wenzel G (eds) *Molecular marker systems in plant breeding and crop improvement*. Springer Verlag, Heidelberg, Germany, pp 39–54
- Moradi F, Ismail AM (2007) Responses of photosynthesis, chlorophyll fluorescence and ROS scavenging system to salt stress during seedling and reproductive stages in rice. *Ann Bot* 99:1161–1173
- Moradi F, Ismail AM, Gregorio GB, Egdane JA (2003) Salinity tolerance of rice during reproductive development and association with tolerance at the seedling stage. *Ind J Plant Physiol* 8:105–116
- Morrell PL, Toleno DM, Lundy KE, Clegg MT (2005) Low levels of linkage disequilibrium in wild barley (*Hordeum vulgare* ssp. *spontaneum*) despite high rates of self-fertilization. *Proc Natl Acad Sci USA* 102:2442–2447
- Nandi S, Subudhi PK, Senadhira D, Manigbas NL, SenMandi S, Huang N (1997) Mapping QTLs for submergence tolerance in rice by AFLP analysis and selective genotyping. *Mol Gen Genet* 255:1–8
- Neeraja CN, Maghirang-Rodriguez R, Pamplona A, Heuer S, Collard BCY, Septiningsih EM, Vergara G, Sanchez D, Xu K, Ismail AM, Mackill DJ (2007) A marker-assisted backcross approach for developing submergence-tolerant rice cultivars. *Theor Appl Genet* 115:767–776
- Ni JJ, Wu P, Senadhira D, Huang N (1998) Mapping QTLs for phosphorus deficiency tolerance in rice (*Oryza sativa* L.). *Theor Appl Genet* 97:1361–1369
- Nordborg M, Tavaré S (2002) Linkage disequilibrium: what history has to tell us? *Trend Genet* 18:83–90
- Olsen KM, Caicedo AL, Polato N, McClung A, McCouch SR (2006) Selection under domestication: evidence for a sweep in the rice waxy genomic region. *Genetics* 173:975–983
- Paran I, Zamir D (2003) Quantitative traits in plants: beyond the QTL. *Trends Genet* 19:303–306
- Price AH (2006) Believe it or not, QTLs are accurate!. *Trends Plant Sci* 11:213–216
- Pujar A, Jaiswal P, Kellogg E, Ilic K, Vincent L, Avraham S, Stevens P, Zapata F, Reiser L, Rhee S, Sachs M, Schaefer M, Stein L, Ware D, McCouch S (2006) Whole plant growth stage ontology for angiosperms and its application in plant biology. *Plant Physiol* 142:414–428
- Rakshit S, Rakshit A, Matsumura H, Takahashi Y, Hasegawa Y, Ito A, Ishii T, Miyashita NT, Terauchi R (2007) Large scale DNA polymorphism study of *Oryza sativa* and *O. rufipogon* reveals the origin and divergence of Asian rice. *Theor Appl Genet* 114:731–743
- Remington DL, Thornsberry JM, Matsouka Y, Wilson LM, Whitt SR, Doebley J, Kresovich S, Goodman MM, Buckler ES 4th (2001) Structure of linkage disequilibrium and phenotypic associations in the maize genome. *Proc Natl Acad Sci USA* 98:11479–11484
- Ren ZH, Gao JP, Li LG, Cai XL, Huang W, Chao DY, Zhu MZ, Wang ZY, Luan S, Lin HX (2005) A rice quantitative trait locus for salt tolerance encodes a sodium transporter. *Nat Genet* 37:1141–1146
- Sahi C, Singh A, Kumar K, Blumwald E, Grover A (2006) Salt stress response in rice: genetics, molecular biology and comparative genomics. *Funct Integr Genomics* 6:263–284
- Salvi S, Tuberosa R (2005) To clone or not to clone plant QTLs: present and future challenges. *Trends Plant Sci* 10:297–304
- Sarkar R, Reddy JN, Sharma SG, Ismail AM (2006) Physiological basis of submergence tolerance in rice and implications for crop improvement. *Curr Sci* 91:899–906
- Sax K (1923) The association of size differences with seed-coat pattern and pigmentation in *Phaseolus vulgaris*. *Genetics* 8:552–560
- Septiningsih EM, Pamplona AM, Sanchez DL, Maghirang-Rodriguez R, Neeraja CN, Vergara GV, Heuer S, Ismail AM, Mackill DJ (2009) Development of submergence-tolerant rice cultivars: the *Sub1* locus and beyond. *Ann Bot* 103:151–160
- Shimizu T, Satoh K, Kikuchi S, Omura T (2007) The repression of cell wall- and plastid-related genes and the induction of defense-related genes in rice plants infected with *rice dwarf virus*. *Mol Plant Microbe Interact* 20:247–254
- Singh S, Mackill DJ, Ismail AM (2009) Responses of *SUB1* rice introgression lines to submergence in the field: Yield and grain quality. *Field Crops Res* 113:12–23
- Sweeney MT, Thomson MJ, Pfeil BE, McCouch SR (2006) Caught red-handed: Rc encodes a basic helix-loop-helix protein conditioning red pericarp in rice. *Plant Cell* 18:283–294
- Sweeney MT, Thomson MJ, Cho YG, Park YJ, Williamson SH, Bustamante CD, McCouch SR (2007) Global dissemination of a single mutation conferring white pericarp in rice. *PLoS Genet* 3:e133
- Szalma SJ, Buckler ES, Snook ME, McMullen MD (2005) Association analysis of candidate genes for maysin and chlorogenic acid accumulation in maize silks. *Theor Appl Genet* 110:1324–1333

- Tanksley SD (1993) Mapping polygenes. *Annu Rev Genet* 27:205–233
- Temnykh S, DeClerck G, Lukashova A, Lipovich L, Cartin-hour S, McCouch SR (2001) Computational and experimental analysis of micro-satellites in rice (*Oryza sativa* L.): Frequency, length variation, transposon associations and genetic marker potential. *Genome Res* 11:1441–1452
- Tenaillon MI, Sawkins MC, Long AD, Gaut RL, Doebley JF, Gaut BS (2001) Patterns of DNA sequence polymorphism along chromosome 1 of maize (*Zea mays* ssp. *mays* L.). *Proc Natl Acad Sci USA* 98:9161–9166
- Thoday JM (1961) Location of polygenes. *Nature* 191: 368–370
- Thornsberry JM, Goodman MM, Doebley J, Kresovich S, Nielsen D, IV BES (2001) Dwarf8 polymorphisms associate with variation in flowering time. *Nat Genet* 28: 286–289
- Toojinda T, Siangliw M, Tragroonrung S, Vanavichit A (2003) Molecular genetics of submergence tolerance in rice: QTL analysis of key traits. *Ann Bot* 91:43–253
- Weir B (1996) *Genetic Data Analysis II*. Sinauer Associates, Sunderland, MA, pp 376
- Wilson LM, Whitt SR, Ibanez-Carranza AM, Goodman MM, Rocheford TR, Buckler ES (2004) Dissection of maize kernel composition and starch production by candidate gene association. *Plant Cell* 16:2719–2733
- Wissuwa M, Ae N (2001a) Genotypic variation for tolerance to phosphorus deficiency in rice and the potential for its exploitation in rice improvement. *Plant Breed* 120:43–48
- Wissuwa M, Ae N (2001b) Further characterization of two QTLs that increase phosphorus uptake of rice (*Oryza sativa* L.) under phosphorus deficiency. *Plant Soil* 237:275–286
- Wissuwa M, Yano M, Ae N (1998) Mapping of QTLs for phosphorus-deficiency tolerance in rice (*Oryza sativa* L.). *Theor Appl Genet* 97:777–783
- Wissuwa M, Wegner J, Ae N, Yano M (2002) Substitution mapping of *Pup1*: a major QTL increasing phosphorus uptake of rice from a phosphorus-deficient soil. *Theor Appl Genet* 105:890–897
- Xu K, Mackill DJ (1996) A major locus for submergence tolerance mapped on rice chromosome 9. *Mol Breed* 2:219–224
- Xu K, Xu X, Fukao T, Canlas P, Maghirang-Rodriguez R, Heuer S, Ismail AM, Bailey-Serres J, Ronald RC, Mackill DJ (2006) *Sub1A* is an ethylene-response-factor-like gene that confers submergence tolerance to rice. *Nature* 442:705–708
- Yeo AR, Flowers TJ (1986) Salinity resistance in rice (*Oryza sativa* L.) and a pyramiding approach to breeding varieties for saline soils. *Aust J Plant Physiol* 13: 161–173
- Zhang N, Xu Y, Akash M, McCouch S, Oard J (2005) Identification of candidate markers associated with agronomic traits in rice using discriminant analysis. *Theor Appl Genet* 110:721–729
- Zhu JK (2003) Regulation of ion homeostasis under salt stress. *Curr Opin Plant Biol* 6:441–445



## Stress, Mutators, Mutations and Stress Resistance

Jonathan Gressel\* and Avraham A. Levy  
*Department of Plant Sciences, Weizmann Institute of Science,  
Rehovot-76100, Israel*

Summary .....	471
I Introduction-Stress Induced Changes in Mutation Frequency .....	472
II Mutator Genes .....	472
A Mutators in Bacteria .....	472
B Mutators in Eukaryotes .....	474
C Organellar Mutators .....	475
III Mutators in Stress Resistance – Implications.....	476
IV Genetic, Circumstantial and Speculative Evidence for Mutators in Resistance to Stress .....	477
V Can Stress Increase the Mutation Frequency to Resistance? .....	478
VI Conclusions.....	480
Acknowledgements .....	481
References .....	481

### Summary

Organisms need genetic mechanisms to rapidly adapt to changing, stressful environments. Having a high mutation frequency would have a drag on a population due to the deleterious nature of mutations, but having a sub-population with high mutation rate due to the presence of mutator genes seems to be nature's solution. Far more is known about mutator genes in bacteria than in higher organisms. Mutator effects can be genetic, through mutations in genes that affect genome stability or it can be epigenetic through up- or down-regulation of these genes. The mutator genes can be genes with partially lost function, which deal with DNA replication or repair, or with detoxification of DNA-damaging cellular components. Transposons, which are sensitive to environmental stress, can also act as mutators in plants. Mutators can be constitutive or stress-induced. Most evidence for mutator-assisted evolution of stress resistance in plants is circumstantial, except for the evolution of atrazine herbicide resistance due to a nuclearly-inherited plastome mutator, which was repeated experimentally. An important feature of the mutator effect is that it is transient and is followed by reversion to the stable wild type, and can be counter-selected following outcrossing with the wild type. Similarly, "remembered" epigenetic stress-induced mutator effects were shown to last for a few generations. In summary, mutator genes could be playing an important role in the evolution of resistance to stress in plants, as it does in other systems, but to an extent that is yet unclear.

Keywords: mutators • transposons • epigenetic effects • evolution

---

\* Author for Correspondence, e-mail: jonathan.gressel@weizmann.ac.il

*“Life is like riding a bicycle – To keep your balance you must keep moving” – Albert Einstein*  
*To keep your balance against stress – you must keep mutating*

## I Introduction-Stress Induced Changes in Mutation Frequency

The long held concept that mutation frequencies were immutable has been falling by the wayside as more has been learnt about the molecular biology of gene replication and how mistakes are repaired (corrected) or are passed on as mutations (Hughes 1999). The rate of spontaneous mutations depends on the organism, the genetic makeup of the organism, the type of cells and the type of sequences and, whether they contain transposons or di- and tri-nucleotides being highly unstable. In recent years, it became apparent that environmental, biotic and abiotic stresses also contribute to alterations in genomic stability.

From an intuitive point of view, it seems logical that there might be an advantage if there could be more mutations when an organism needs change, e.g., wild species need stress tolerance when continually confronted with desertification, a crop when continually plagued by a disease, and a weed ‘needs’ resistance when the species is continually sprayed with a herbicide. Conversely, it would also be logical to assume that high mutation rates would be undesirable when they are not needed, as most mutations are deleterious. Both of these bits of intuitive logic have some Lamarckian flavor, however, the basic Darwinian tenets are so far maintained, as there is little or no evidence for directed mutation and eventually, the adapted genotypes can be fixed by natural selection. Thus, the ability to have mutation rates change under stress may then be considered to provide evolutionary advantages.

Environment-dependent changes result from the induction or suppression of mutator mechanisms that have a genome-wide effect on mutation rate. While there is a cost to mutations (most are unfit), there is also a metabolic cost to error correction. The cost of mutations can decrease when variation is needed, and the

cost of corrections increases when an organism is resource limited or stressed as when an environment changes (Travis and Travis 2002). Much of the evidence for stress-induced mutations stems from bacteria, but there is some evidence from eukaryotic organisms, including plants. This evidence is discussed in the following sections. The issue is an important one, as the rate of evolution of stress resistance is heavily modulated by mutation frequency.

## II Mutator Genes

### A Mutators in Bacteria

Far more is known about mutators in bacteria than in plants or animals. It is thus necessary that we first discuss what is known in these organisms. There have been a spate of reviews that have extensively covered ‘SLAM’ (stress lifestyle-assisted mutations) or hypermutations, how they exist and are used in evolution (Rosenberg et al. 1998; Horst et al. 1999; Tenaillon et al. 1999; Boe et al. 2000; Harfe and Jinks-Robertson 2000; Metzgar and Wills 2000; Fernandes et al. 2004). In a normal wild type culture of a bacterium such as *E. coli*, a sub-population of 0.01–1% of the cells has an ultrahigh mutation rate. These cells are said to contain a ‘mutator’ gene or genes. The frequency of cells with such high mutation rates in *Salmonella* is considerably lower (LeClerc et al. 1998). With one *E. coli* mutator system, which increased the rate of mutation 20–80-fold depending on the gene observed, the fitness load was 1% less than wild type (Boe et al. 2000). This minute decrease in fitness was sufficient to keep the mutator-bearing cells at a low frequency when cells are on a complete medium and are otherwise not stressed. If the population is stressed such that mutations will have an advantage, it is most likely that the needed mutation will be found more quickly in the small proportion of cells with the high mutation rates than in the ‘slow to respond’, dowdy, mutation-conservative cells within the population. Once the population has taken on the new trait, the high mutation frequency is deleterious, as most mutations are lethal or harmful. There is then an advantage for fixing the desirous stress adaptive trait into the mutationally conservative population in the cells, or conversely, in suppressing the deleteriously high mutation rate in the adaptively evolved population. This fixation

---

*Abbreviations:* HPPD – hydroxyl phenyl-pyruvate-dioxygenase; MULE – Mu-like elements; SLAM – stress lifestyle-assisted mutations

of the desired trait and removal of the mutator are facilitated by sexual conjugation and segregation of progeny in subsequent generations. How this effects the rates of appearance of mutations has been mathematically modeled (Taddei et al. 1997; Funchain et al. 2000).

Various mutator systems have been isolated in *E. coli* and characterized both genetically and molecularly (Table 1). In the ‘SOS’ system, genetically described decades ago, the mutations arise when the mechanism repairing DNA lesions becomes error-prone. When there is a lesion in DNA, the polymerase is stalled, which could be lethal. The SOS system activates gene products of

*amuD*<sup>+</sup> *c*<sup>+</sup> and *recA*. Stress-related DNA damage activates RecA to become a protease, which binds to the remaining piece of single-stranded DNA resulting from damage. The activated RecA cleaves a variety of proteins, some of which allow the DNA polymerase to bypass the lesion that blocks replication. In the high mutation rate strains, a mutant *recA* produces a protein that increases mutations 10–20 times. Even when there are no DNA lesions, it causes DNA polymerase III to become error prone. Another SOS gene *dinB* increases spontaneous mutagenesis in the absence of another gene product *umuDC*. How SOS activated has been reviewed by Smith and Walkered

Table 1. Properties of the various mutator genes in *Escherichia coli*.

Gene	Gene product	Function	Specificity
<i>dnaQ</i> ( <i>mutD</i> )	ε subunit of DNA polymerase III, 3→5' exonuclease	Removes incorrectly paired nucleotides during replication (proofreading)	Mostly transversions
<i>polC</i> ( <i>dnaE</i> )	α subunit of DNA polymerase III	Correct nucleotide selection and proofreading	All base substitutions and frameshifts
<i>polA</i>	DNA polymerase I	General repair functions	Deletions, frameshifts
<i>mutA</i> , <i>mutC</i>	Mutated glycyl-tRNA	Missense suppression at aspartate codons in <i>dnaQ</i>	Similar to <i>mutD</i>
<i>mutT</i>	Nucleoside triphosphatase	Prevents mispairing of 8-oxoG with template A during replication	AT → CG
<i>dam</i>	DNA adenine methyltransferase	Methylation imparts strand specificity	GC → AT, AT → GC, frameshifts
<i>mutS</i>	DNA mismatch recognition	Binds DNA mismatches	GC → AT, AT → GC, frameshifts
<i>mutL</i>	68-kDa protein	Stimulates MutS, MutH and Vsr activity	GC → AT, AT → GC, frameshifts
<i>mutH</i>	Endonuclease	Nicks hemi-methylated GATC sequences	GC → AT, AT → GC, frameshifts
<i>uvrD</i>	DNA helicase II	Strand displacement	GC → AT, AT → GC, frameshifts
<i>mutY</i>	DNA glycosylase	Removes A from 8-oxoG–A or A–G mispairs	GC → TA
<i>mutM</i> ( <i>fpg</i> )	DNA glycosylase	Removes 8-oxoG from 8-oxoG–C mispair	GC → TA
<i>miaA</i>	Transferase	Methylthio-isopentyladenosine tRNA modification	GC → TA
<i>sodA</i> , <i>sodB</i>	Superoxide dismutases	Removes superoxide radicals	
<i>oxyR</i>	Regulatory protein	Regulates hydrogen peroxide-inducible genes	AT → TA
<i>nth</i> , <i>nei</i>	Glycosylase and abasic-lyase activity	Removal of oxidized pyrimidine bases	GC → AT
<i>xthA</i> , <i>nfo</i>	Nucleases	5' abasic-endonuclease activity	AT → TA
<i>ung</i>	Uracil glycosylase	Removes U from U–G mispairs	GC → AT
<i>vsr</i>	Endonuclease	Cleaves adjacent to T–G mismatches	GC → AT
<i>ada</i> , <i>ogt</i>	Methyltransferases	Removes methyl groups from O6-methylguanine in DNA	GC → AT
<i>recA</i>	DNA-binding protein	Catalyzes strand pairing and exchange in general recombination; co-protease activity on <i>LexA</i> , <i>UmuD</i> , etc.	GC → TA, AT → TA
<i>recG</i>	DNA helicase	Branch migration of Holliday junctions	Frameshifts
<i>hns</i> ( <i>bgIY</i> )	DNA-binding protein	Histone-like protein involved in chromosome organization	Deletions
<i>topB</i> ( <i>mutR</i> )	DNA topoisomerase III	Appears to decatenate chromosomes	Deletions between small repeats
<i>ssb</i>	Single-stranded DNA-binding protein	Protects single-stranded DNA	Point mutations, rearrangements

Source: Modified from Horst et al. (1999).

(1998), Horst et al. (1999), Radman (1999) and Maliszewska-Tkaczyk et al. (2000).

The SOS system is not the only mutator system in bacteria, a total of 29 are tabulated for *E. coli* in Table 1. In a quirk of nomenclature, various polymerases and other normal enzymes are referred to as ‘mutators’. It should be understood that the wild type forms of these enzymes are normal and there is a mutator effect only when they are mutated. The mutators include faulty DNA-polymerases, -helicases, -methyltransferases, -topoisomerases, -glycosylases, as well as DNA-binding proteins that are associated with DNA stress, specifically replication, repair, protection, chromosome organization, proofreading, mis-sense suppression and strand displacement. Not all mutator gene products cause mutations to defective DNA via polymerase or repair enzyme related proteins. For example, one mutator strain results from the production of less superoxide dismutase than in the wild type. With less superoxide dismutase, there is an accumulation of oxygen radicals that damage DNA more than can be repaired by the normal housekeeping levels of the repair enzymes present in the cell.

The relationship of mutators with plant stress resistance (especially herbicide and xenobiotic resistance) became more apparent when it was found that pathogenic *E. coli* and *Salmonella* have a high incidence of mutator-bearing cells. They also had a thousand-fold greater incidence of rifampicin antibiotic resistance (LeClerc et al. 1996; Matic et al. 1997). There was a selective advantage in hospitals to those organisms that could evolve antibiotic resistance more quickly. Indeed, there is excellent documentation that a mutator is responsible for the hypermutability of a pathogenic *Pseudomonas* to antibiotic resistance in hospitals, where the organism sequentially and rapidly evolved resistance to each antibiotic used, with dire consequences to lung-infected patients (Macia et al. 2005).

Active mutator genes (i.e., defective polymerases) have considerable benefits in stressful conditions by quickly providing the genetic diversity in the form of mutations, a small proportion of which are beneficial. Still, a population with the beneficial mutation is continuously being surrounded by deleterious mutations (termed ‘a ruby in rubbish’) (Peck and Waxman 2000). Thus, there is a considerable advantage to

sexual recombination. The segregation of genes in further sexual generations allows the separation of the ruby from the rubbish. These advantages of sex have been reviewed by Rosenberg et al. (1998) and mathematically modeled by Otto and Michalakis (1998).

In what would appear to be evolutionary suicide for the mutator gene, but best for the organism, there is evidence in bacteria and fungi that some mutators also seem to lower sexual barriers eliciting illicit sexual recombination among related bacterial and among related fungal strains, and even between species that do not normally conjugate with each other (Zahrt and Maloy 1997; Stambuk and Radman 1998). These issues are also relevant to discussions of horizontal gene transfer in microorganisms.

### B Mutators in Eukaryotes

Not all genetic systems found in bacteria (e.g., operons) are found in eukaryotic organisms. Thus, it is necessary to ascertain that what is “found in *E. coli*, is found in elephants” as well as in elephant grass and among plant genes, and has relevance to the evolution of stress resistance.

At the lower end, and easier to manipulate in culture, homologs of the SOS system were found in yeast, but also in mice and humans (Friedberg and Gerlach 1999). The *mutS* and *mutL* gene products have considerable amino acid homology to proteins from bacteria through humans. Mutator mutants in these genes predispose humans to certain cancers (Modrich and Lahue 1996). The various mutators in eukaryotes have been extensively reviewed by Harfe and Jinks-Robertson (2000) and Metzgar and Wills (2000). Similarly, in plants, a *mutS* homolog, *AtMSH2* was shown to be involved in genome stabilization and to have a mutator effect. Mutant *Atmsh2-1* lines rapidly accumulated a wide range of mutations. After five generations of self-fertilization of the mutant, the vast majority of plants were abnormal in morphology and development, in fertility, germination efficiency, while all wild-type lines appeared normal (Hoffman et al. 2004). At the molecular level, a high frequency of microsatellite instability was detected. The consequence of these findings is that in nature, the occurrence of mutations in genes that control genome integrity would rapidly broaden the genetic variation in a



population until out-crossing with the wild type would stabilize the new variation.

There is a positive selection for mutators in some biological systems. The human *polμ* gene is under specific promotion to lymphoid tissue alone, and is considered responsible for providing the variation needed for immunoglobulin genes to produce the spectrum of antibodies needed by the immune system (Dominguez et al. 2000). In plants, there are no known examples of gene-specific mutators. If such mutators were to exist, this would have considerable implications to the evolution of stress resistance. For example, the mutability of genes encoding cytochrome P450 and glutathione transferases, the great xenobiotic detoxification enzymes so often correlated with resistance, would predispose weeds to rapid evolution of resistance to a herbicide degraded by a different cytochrome P450 or glutathione transferase. As there are consensus sequences within the gene families, it is conceivable that there could be DNA-binding-protein type mutators related only to such sequences.

Antibiotic, drug, pesticide, other abiotic and biotic resistances need not be due to just mutations. They can be due to gene amplifications as well. More xenobiotic will be required to bind to a target protein if there is more of the protein. Arsenate and arsenite, two stressful (and carcinogenic) arsenic ions induced gene amplification in mammalian cells (Lee et al. 1988), evidence that stress can select for the enhancement of the frequency of gene amplifications as well.

The best known eukaryotic mutation elements, transposons, can cause a broad range of mutations. The transposons were first described by McClintock (1951) in maize. These mobile pieces of DNA ('jumping' genes) disrupt the function of the genes into which they implant themselves causing an insertion mutation. Upon excision in revertants, transposons can leave footprints of a few nucleotides, creating a more subtle allelic variation. Transposons can also modulate the expression of nearby genes through a variety of mechanisms (methylation, readout transcription, etc) causing changes in expression, such as over-expression, ectopic expression or silencing (Kashkush et al. 2003). Transposons can be responsible for herbicide resistance when weeds are treated with pro-herbicides that must be metabolized to the active form. A transposon

could inactivate the gene required for herbicide activation. Excision footprints can also modify or add single amino acids that can lead to herbicide resistance.

There is evidence in plants for horizontal gene movement of Mu-like Element (MULE) transposons (that act as mutators) among grass species that do not interbreed (Diao et al. 2006). Transposons can be activated in interspecific wheat hybrids and in newly-synthesized polyploids (Kashkush et al. 2003). One could envision that a male sterile interspecific hybrid is back-pollinated by one of its parents such a scenario is likely to take place quite frequently in nature. It would account for stress-activation of transposons and horizontal transfer via a male-sterile hybrid bridge, between species that do not breed. Such mechanisms can transfer transposons, as well as genes that are transduced by transposons, across species. It provides another mechanism for creating a novel stress-induced genetic variation within a species.

### C Organellar Mutators

Mutations in nuclear DNA in generative cells will appear in the following generation (if dominant) or in later generations if recessive. What about mutations in the plastome or chondriome (plastid and mitochondrial genomes)? As the *psbA* gene, the target site of a major group of photosystem II affecting herbicides, is encoded on the plastome, this is not just an academic question. There are many plastids in a cell, each with many copies of DNA. How frequently would we see the effects of a plastid mutation? Duesing (1983) calculated that the frequency of female gametes normally with a mutated plastome gene should be about  $10^{11}$  to  $10^{12}$ . The frequencies were derived by dividing the frequency of leaves having mutated spots [ $(10^{-5})$  (Hagemann 1971)] by 50, i.e., the estimated number of genes that could give rise to those spots, and again by 5,000 i.e., the difference between the frequency of loss of the catalytic function (leaf spots) and obtaining a functional protein with modified properties as suggested by Lederberg and Lederberg (1952), and by 10–100, i.e., the presumed ability of a species to have sector mutations appear in the germline. These calculations did not take into consideration the functional recessiveness of mutant *psbA* at field

light intensities that generate oxygen radicals. A rougher calculation by back extrapolating from the types of curves by modeling suggests  $10^{-15}$  to  $10^{-20}$  (Gressel and Segel 1982). Thus, it seems hard to envisage the possibility of evolution of resistance to herbicides such as the triazines in wild type plants without mutators.

In one place where measured, a plastome mutator elevated the frequency of mutations 1,000-fold (GuhaMajumdar et al. 2004). A recessively nuclear encoded plastome mutator *chm1* in *Arabidopsis* has been well genetically characterized. It increases the frequency of plastid mutations a million fold (Redei 1973; Redei and Plurad 1973), not an inconsequential amount. A similar mutator, *iojap* has been characterized to cause plastome mutations in maize (Byrne and Taylor 1996). The *Arabidopsis* lines with the homozygous *chm1* contained a mixture of mutant types, but removing the mutator by outcrossing it away allowed the segregation of the different lines, each uniformly containing a single different plastid mutant type (Mourad and White 1992). Chloroplast mutator *chm1-3* also induces mitochondrial mutations (Sakamoto et al. 1996). In the case of triazine herbicide resistance, one can assume that continual treatment with the triazines provides a selective advantage only to the plastome mutants that are triazine resistant, and the rest of the plastid mutations will disappear.

Another nuclear gene that affects genome stability in the mitochondria is the AtMSH1 gene (a nuclear-encoded MutS homolog). In the mutant, new mitochondrial chromosomal forms are detected (Abdelnoor et al. 2003). Interestingly, the mutator effect of AtMSH1 can be exploited to generate novel types of cytoplasmic male sterility, which becomes irreversible even when the mutator gene is replaced by the wild type gene (Sandhu et al. 2007). From this, it would appear that a mutator would be far more efficacious in 'assisting' the evolution of resistance in species that are not obligate inbreeders. Some outcrossing would be necessary to remove the mutator gene. Thus, one would expect more cases of triazine resistance in species that are at least partially outcrossing, which indeed seems to be the case.

One remarkable feature of organellar mutators is that their effect can be confined to a specific

organelle. This is unlike chemical mutators which have a non-discriminatory effect on all DNAs.

### III Mutators in Stress Resistance – Implications

The information that the evolution of resistance to stresses may be related to mutator-elevated mutation levels is genetic (at best) or phenomenological or speculative (at worst). The reasons they are presented is because the questions about their existence and about their relevance are amenable to solution, not just speculation now that molecular probes have become available, due to the homology of many eukaryotic mutator genes to those of bacteria.

If mutators are truly a significant factor in the evolution of some types of stress resistances, we must modify our models on evolution of resistance and concepts of resistance management accordingly. It had been assumed that resistance genes were present at a fixed frequency in the population and (most importantly) that the mutation of one gene was independent of another. This was the basis for many strategies to delay or even almost preclude the evolution of resistance of herbicide resistant weeds (Gressel and Segel 1978, 1982).

In a previously non-stressful environment, the frequency of a stress resistance gene is the sum of the frequencies of stress resistance in a non-mutator population plus the product of the frequency of mutator genes in the population, times the frequency of stress resistance in the mutator population. Once resistance evolves to the first stress in a population containing a mutator, the mutator is in a high frequency in the population, and will remain at a much higher frequency than its initial frequency before selection, even as resistance is sexually segregated away from the mutator. It is highly likely then that resistance will quickly evolve when a second and subsequent stresses with no known cross resistance to the first stress impinge on the species, providing the species with a selective advantage over species with low mutator frequencies. Thus, the frequency of resistance to the second stress will be that of the mutator population, perhaps a thousand times higher than in the wild type population. Similarly, if part of a population of weeds is under stress conditions

that select for mutator-enhanced weeds, this sub-population may evolve herbicide resistance more rapidly than the wild type weed.

Some of the worst weeds are exceedingly diverse and seem to be able to quickly adapt to many changes in agricultural environment as well as to herbicides. Is their adaptability a result of a higher frequency of a mutator and/or do the herbicides provide a stress that enhances mutator effects? Or is there a positive selection for mutator plants? Importantly, many genes control genome stability in plants (Bray and West 2005), so a knockout mutation in any of these genes would increase the chances for very rare mutations to take place in specific stress resistant genes. The possible mutator effect of transposons cannot be ignored in elucidating the causes of stress resistance. Transposons are usually silent in the genome, however, they have the unique ability to sense stress and to be activated by it (McClintock 1984). Thus, they could generate stress resistant mutations, via footprints or by insertional mutagenesis. A central and still unsolved question in evolutionary biology is “why are most eukaryotic genomes infested with so-called junk DNA, much of which is composed of transposons? A possible answer is that they are not mere “neutral guests” in the genome but that their ability to respond to stress and to become stress-induced mutators, contributes to the species fitness in many environments.

The capacity to possess mutators might be an inherent property of the most adaptable species. Indeed highly adaptable species such as the interbreeding *Lolium rigidum*, *L. perenne*, *L. multiflorum* complex of pasture grasses and weeds (Cunliffe 2005) have evolved resistance to a multitude of environmental stresses and herbicides at an astounding rate throughout the world (Gressel 2002; Preston 2003; Neve and Powles 2005; Owen et al. 2007; Heap 2008). No one has yet determined whether this rapid evolution is facilitated by mutators, and it may not be easy to find a population with low mutation frequencies. Weediness is considered to be a syndrome, where some but not necessarily all properties of a variety are typically present (Warwick and Stewart 2005). These include properties such as secondary dormancy, seed shattering, competitiveness, variability adaptability and large seed output. Perhaps the variability and the adaptability are a

function of the presence of mutators, and research to see if these species have stable, wild progenitors is called for.

#### IV Genetic, Circumstantial and Speculative Evidence for Mutators in Resistance to Stress

Early historic evidence that may be relevant to mutators and stress resistance in eukaryotes was found before mutators were known. The first houseflies resistant to DDT were highly unfit, but backcrossing to the wild type enhanced population fitness until it was imperceptibly different from normal (Crow 1957). Did DDT resistance evolve in an unfit mutator-containing population, with the mutator gene later sexually segregating away from resistance?

Triazine resistance seems as if it should be rarer than it is. The wild type gene product generates toxic radicals under the intensities of light found in the field, which is why the herbicide is toxic. The resistance gene is plastome encoded, and there are many copies of DNA per chloroplast and often many chloroplasts per female gamete. Even if you have one mutant *psbA* gene product not affected by the herbicide it has many non-mutant neighbors from unmutated *psbA* spewing out toxic radicals in the light. Thus, resistance is functionally recessive and should be lost due to the toxic neighbor cells.

Herbicide resistance is rarely studied in nascent-resistant populations. The farmer usually notices and reports resistance after a large proportion of a field is covered with resistant individuals, which could be generations after the initial patch appeared. Thus, it was fortuitous that many plants in a nascent atrazine resistant population of *Solanum nigrum* that had recently evolved, had leaf mosaics with many different chlorophyll types, which attracted researchers' attention. This was taken to indicate that there may be a nuclear-encoded plastome mutator gene in the population responsible for the *psbA* mutation conferring triazine resistance as well as for the other plastome anomalies. The requisite crosses were performed that could separate the mosaic population from the triazine-resistant population, providing the needed genetic evidence for a nuclear encoded plastome muta-

tor gene (Arntzen and Duesing 1983). Further supportive evidence for a plastome mutator being responsible for the mutation leading to triazine resistance comes from the sequence analyses of the *psbA* gene. This gene is exceedingly conservative and mutations are rare. Yet, the resistant biotypes often had secondary (silent) mutations that did not change the amino acid sequence along with the *psbA* ser<sub>264</sub> → gly mutation (Oettmeier 1999). *Phalaris paradoxa* even had a second amino acid transversed in a part of the molecule where there was little effect on the binding site (Schönfeld et al. 1987). These data could be taken to suggest that a mutator was active, causing many mutations, including triazine resistance. These circumstantial data have been supported by experimental data. Atrazine resistance was selected for in barley populations that either possessed or lacked a nuclear-encoded plastome mutator. Resistant mutations were only found in the line with the mutator (Rios et al. 2003).

The propensity of *Lolium rigidum* to evolve resistance to a large number of herbicides is described above. When *Lolium* evolved resistance for the first time to a herbicide in Australia, there was a lag on increasing resistance in the population (Heap 1988), which was not as apparent with subsequent herbicides. Could the lag of increase in resistance be seen due to an initial enrichment for a mutator, which then supplies the small mutations that incrementally enhance the level of resistance in the population? Better evidence for a mutator in the resistant population comes from the data of Tardif and Powles (1994). They subjected a pristine population of *Lolium rigidum*, as well as a population that had already evolved various herbicides to the herbicide sethoxydim. Both populations were initially susceptible, but the population with other resistances (and a mutator?) quickly evolved resistance to sethoxydim. Other interpretations of the data are possible. There could have been simultaneous selection for target site and degradation mutations, and the target site mutants to sethoxydim were in a low frequency. Unfortunately, the authors have neither reported the genetics nor have they looked at the frequency of unrelated genes to verify the presence or absence of a mutator in *Lolium* species.

## V Can Stress Increase the Mutation Frequency to Resistance?

The question above is often asked, with the questioner implying the possibility of a *directed* mutation towards resistance to only the specific impinging stress. Two partial answers to the question are rather clear: (a) directed mutagenesis towards a specific trait alone has not been demonstrated. As we saw with atrazine resistance, the populations had many other plastid mutations; and (b) lethal stresses cannot increase mutation frequency, as dead plants do not reproduce. At lethal levels, stresses can only select for pre-existing mutations that are present before the stress appeared.

The question though is valid for sub-lethal herbicide rates and other non-lethal stresses, in both crops and weeds. For example, do herbicides provide the stress that can select for mutators? This question can only be answered in situations where herbicides do not kill the plant, but cause some sort of transient stress. There are two situations where this may occur: (a) during the period after herbicide application and until the herbicide is eliminated by metabolism within crops that exert metabolic resistance to a herbicide; and (b) in weeds that are underdosed with a herbicide (Gardner et al. 1998). Underdosing can be due to: (a) using low levels of herbicide; (b) by treating at a time when the weeds are less susceptible; (c) unequal application to a field; and (d) in dormant weeds, naturally emerging long after a soil herbicide was applied, when much of the herbicide has dissipated. The ideal system for a plant is to have a mutator that is induced by the stress itself, and can remain “dormant”, without reducing fitness, until it is needed and activated by the stress. Such a mutator was found in *Arabidopsis*, which is activated by both high and low temperature stresses, but is inactive at normal temperatures (Young et al. 2005). This mutator causes all types of mutations, not just to heat or cold tolerance, so the mutations are not “directed”.

A very easy and efficient system was developed to measure small differences in mutation frequencies using maize pollen grains (Plewa 1985). It utilizes pollen from a “waxy” (starch free) mutant of maize. There is a back mutation in the pollen to ‘starchy’ at a finite frequency. This starchy



phenotype is easily seen microscopically after staining the pollen grains with iodine, which specifically stains the starchy back mutants (Plewa 1985). Presumably, this system could easily be adapted to automated flow-through counting. Maize treated with atrazine had pollen with a doubled frequency of starchy pollen grains; atrazine somehow doubled the mutation frequency using this system (Plewa 1985). Extracts from similarly treated maize plants were mutagenic to *Salmonella* in an “Ames test” mutational analysis (Means et al. 1988). Is this specific to atrazine and maize? Perhaps it is not relevant to all stresses. Atrazine stops photosynthesis for a day after a foliar application until it is metabolized (Ducruet and Gasquez 1978). During that period, the inhibited chloroplasts would be generating free radicals that could cause DNA lesions, not all of which can be repaired. Soil-applied atrazine might be continually causing a low-grade stress in maize, causing more DNA lesions than can be repaired by the various repair enzymes.

More simple assays such as pollen assays are needed and should be used. Pollen has long been known to express a surprisingly large number of genes used by the sporophyte (Tanksley et al. 1981; Pedersen et al. 1987; Ottaviano et al. 1990). Pollen assays for ALS and ACCase target site resistance have been developed in some of the highly adaptive grasses (Richter and Powles 1993, Letouze and Gasquez 2003). The mutation frequencies could (but have not) been examined in *Lolium* populations that have evolved resistance to other herbicides, from other stressful environments, from ruderal populations growing on disturbed but not cultivated land, comparing them with pristine populations in the wild to answer some of the questions raised above.

Molecular based tests have also been developed to assay for mutagenic activity of xenobiotics and stresses in *Arabidopsis* (Kovalchuk et al. 2000, 2001). These include transforming plants with a  $\beta$ -glucuronidase (*gus*) gene containing a single nonsense mutation. Another assay consists of monitoring of intra-chromosomal homologous recombination between overlapping repeats of a truncated *gus* gene. In this assay, the *gus* gene becomes reactivated upon homologous recombination, which is monitored as blue sectors upon histochemical staining (Swoboda et al. 1994). Tissues are stained before and after being subjected

to a putative mutagen for back mutations that stain for GUS activity. In general this seems more complicated than the waxy pollen grain reversion. Still, such constructs could be engineered into any species (such as *Lolium*) to ascertain whether the species or the biotype has a higher frequency of natural as well as stress-induced mutations. Several studies with the GUS assay point to induction of genetic instability by various biotic and abiotic stresses (see examples and references in Boyko et al. 2005).

In general, high rates of DNA recombination positively correlated with the concentration of peroxide produced by the plant. In other words, the genome maintenance machinery is affected by stress, probably oxidative stress, thus providing a link between environmental stress and mutagenesis. Some herbicides induce oxidative stress (as discussed below) and might thus enhance genomic instability in plants that are not killed.

Another exciting recent finding is that stresses seem to trigger genomic instabilities through the induction of epigenetic alterations that can be memorized for several generations, even in the absence of stress (Molinier et al. 2006; Bruce et al. 2007). It is thus tempting to speculate that an environmental stimulus, such as a sub-lethal stress, can induce a mutator effect that can last for a few generations, thus giving rise to novel resistant types. The reported enhancement of homologous recombination by both biotic and abiotic stresses (Molinier et al. 2006) could trigger recombination between repeats, causing deletions (in the case of direct repeats in cis), inversions (for inverted repeats), duplications (e.g., through unequal crossover) and translocations. At the molecular level, changes in DNA methylation or in chromatin modifications could up- or down-regulate the activity of mutator genes. Remarkably, this effect lasts for at least four generations, giving ample time for the accumulation of a variety of mutations and eventually, the reversion to the wild type may stabilize the population and provide the opportunity for selection of resistant individuals.

It is possible to understand how some herbicides could increase mutation frequency. For example, oxidative stress caused by atrazine results in lesions in DNA (Means et al. 1988; Plewa 1985); more the lesions, the greater inability of repair enzymes to correct the introduced errors. There

is evidence that part of the mutation mitigation occurs before there is photo-oxidative damage to the DNA. Much of the production of reactive oxygen is immediately detoxified and when the enzymes of this process are defective or inactive, there is an increase in the rate of mutation. Thus, defective superoxide dismutase might be considered as one of the many “mutator genes” (Table 1). Many herbicides indirectly cause oxidative stress through their metabolic function e.g., glyphosate by preventing syntheses of ultraviolet light absorbing flavonoids, 4-hydroxyphenyl-pyruvate-dioxygenase (HPPD) inhibitors of quinone synthesis could have the same indirect effect on mutation rate by causing more DNA lesions than repair enzymes can fix. These mutations would usually occur in only somatic tissue, as the herbicides are applied well before flowering. They should have dissipated before cell division in the control zone of the apex begins giving rise to floral structures. This zone has very few divisions during vegetative growth. Thus, these cells should not be greatly affected by mutations occurring during DNA replication.

Herbicides and xenobiotics that do not cause oxidative stress, can also, in theory, increase the mutation rate. For example, acetolactate synthase inhibiting herbicides rapidly affect DNA synthesis (Ray 1982) by indirectly blocking purine biosynthesis. Partial deficiency of one nucleotide often leads to base substitutions, i.e., mutations. Many other herbicides affect cell division either through unknown means or through blocking alpha-tubulin/

microtubule formation. Faulty division can lead to chromosomal rearrangements. At sub-lethal levels this can result in mutational events.

## VI Conclusions

The genetic ability to adapt to changing environments is an attribute of many plant species. We posit that mutability, via a mutator system, is the likely cause of genetic adaptability in some of these species (Fig. 1). The likelihood is strongest in species producing copious amounts of seeds, where thousands of seeds are produced to replace a single individual. The ‘cost’ of having many deleterious mutations is low in such large populations. They may have a higher frequency of mutator genes or a generally higher frequency of mutations due to different polymerases. Evolution of resistance can be rapid with species that produce many seeds for two reasons: (a) If the mutation frequency is at a fixed rate (no mutators). There is a higher frequency of resistant seeds per unit area with an *Amaranthus* producing thousands of seeds per plant and per meter as compared to a weed producing few seeds at a fixed mutation frequency. In contrast, a legume weed produces hundreds of seeds, and (b) If there is a mutator, then there will be many more mutations generated per hectare.

The ability of plants to survive stressful environments might result from a predisposition to have and utilize mutators combined with

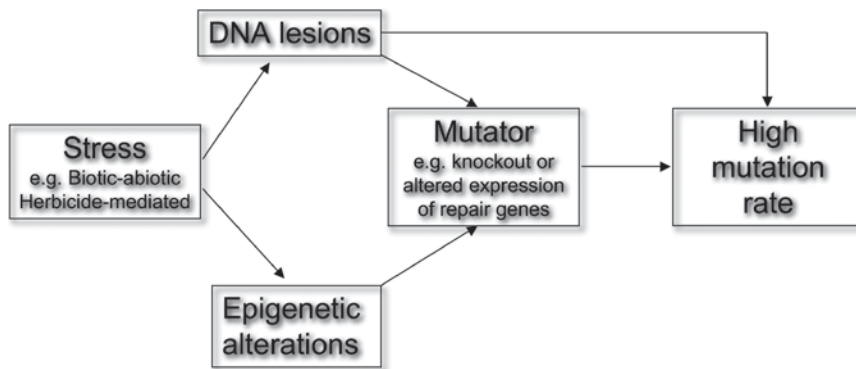

Fig. 1. A proposed model for stress-induced mutability of the plant genome. Stress might directly cause DNA lesions or epigenetic alterations that affect the functioning of the DNA repair machinery in a way that promotes the rapid formation of a new genetic variation (the mutator effect). Applying the mutator strategy to large populations enables the isolation of very rare mutations, including those that might confer stress resistance.

a prolific seed production. One can formulate various testable hypotheses on how plants might effectively achieve stress resistance. The mutator effect might be caused by an overall increased rate of DNA lesions directly induced by stress-mediated production of oxygen free-radicals. DNA lesions can in principle be repaired by the DNA repair machinery; however, if plants tend to have “sloppy” error prone DNA repair machinery they will rapidly accumulate mutations. An alternative model is that stresses in general, including oxidative stresses, do not directly generate DNA lesions, but rather induce epigenetic alterations in chromatin structure and thus in gene expression (Molinier et al. 2006; Bruce et al. 2007). Such alterations might have evolved and have modified the expression of the genome maintenance machinery in a way that increases mutation and recombination rates for a number of generations. Finally, although all the evidence from recent studies suggests that a mutator strategy is both achievable and beneficial to the stressed species, it still remains to be proven that such mechanisms do in fact contribute to a specie’s evolution.

Mutator systems have some unique features compared to chemical mutagenesis. First, their effect can be confined to organellar or nuclear genes. Second, the spectrum of mutations induced by mutators is different from that of chemicals. It consists of a broad range of events, such as insertions, deletions, inversions, duplications, translocations and microsatellite instability. Third, their effect is spread throughout several generations, unlike mutagens which are usually given in one treatment. This enables the fixation of some mutations while giving an opportunity for deleterious genes to segregate out. Mutator systems have far-reaching evolutionary implications. Their use in mutation breeding of crops has been limited so far (see above examples of male sterility (Sandhu et al. 2007) and herbicide resistance (Rios et al. 2003). Mimicking nature’s tricks might help breed for stress resistance in plants.

## Acknowledgements

A.A.L thanks the Gilbert de Botton Professorship of Plant Sciences.

## References

- Abdelnoor RV, Yule R, Elo A, Christensen AC, Meyer-Gauen G, Mackenzie SA (2003) Substoichiometric shifting in the plant mitochondrial genome is influenced by a gene homologous to MutS. *Proc Natl Acad Sci USA* 100:5968–5973
- Arntzen CJ, Duesing JH (1983) Chloroplast-encoded herbicide resistance. In: Ahmand F, Downey K, Schultz J, Voellmy RW (eds) *Advances in gene technology*. Academic Press, New York, pp 273–299
- Boe L, Danielsen M, Knudsen S, Petersen JB, Maymann J, Jensen PR (2000) The frequency of mutators in populations of *Escherichia coli*. *Mutat Res* 448:47–55
- Boyko A, Filkowski J, Kovalchuk I (2005) Homologous recombination in plants is temperature- and day-length dependent. *Mutat Res – Fundam Mol Mech Mutagen* 572:73–83
- Bray CM, West CE (2005) DNA repair mechanisms in plants: crucial sensors and effectors for the maintenance of genome integrity. *New Phytol* 168:511–528
- Bruce TJA, Matthes MC, Napier JA, Pickett JA (2007) Stressful “memories” of plants: evidence and possible mechanisms. *Plant Sci* 173:603–608
- Byrne M, Taylor WC (1996) Analysis of mutator-induced mutations in the *iojap* gene of maize. *Mol Gen Genet* 252:216–220
- Crow JF (1957) Genetics of insect resistance to chemicals. *Ann Rev Entomol* 2:227–246
- Cunliffe K (2005) The ryegrass complex. In: Gressel J (ed) *Crop ferality and volunteerism*. CRC Press, Boca Raton, FL, pp 236–242
- Diao XM, Freeling M, Lisch D (2006) Horizontal transfer of a plant transposon. *PLoS Biol* 4:119–128
- Dominguez O, Ruiz JF, de Lera TL, Garcia-Diaz M, Gonzalez MA, Kirchoff T, Martinez AC, Bernad A, Blanco L (2000) DNA polymerase mu (*Pol mu*), homologous to *TdT*, could act as a DNA mutator in eukaryotic cells. *EMBO J* 19:1731–1742
- Ducruet JM, Gasquez J (1978) Observation of whole leaf fluorescence and demonstration of chloroplastic resistance to atrazine in *Chenopodium album* L. and *Poa annua* L. *Chemosphere* 8:695–699
- Duesing JH (1983) Genetic analysis of herbicide resistance. *Proc North Central Weed Control Conf* 38:143–147
- Fernandes J, Dong QF, Schneider B, Morrow DJ, Nan GL, Brendel V, Walbot V (2004) Genome-wide mutagenesis of *Zea mays* L. using RescueMu transposons. *Genome Biol* 5(10):R82
- Friedberg EC, Gerlach VL (1999) Novel DNA polymerases offer clues to the molecular basis of mutagenesis. *Cell* 98:413–416
- Funchain P, Yeung A, Stewart JL, Lin R, Slupska MM, Miller JH (2000) The consequences of growth of a mutator strain of *Escherichia coli* as measured by loss of function

- among multiple gene targets and loss of fitness. *Genetics* 154:959–970
- Gardner SN, Gressel J, Mangel M (1998) A revolving dose strategy to delay the evolution of both quantitative vs. major monogene resistances to pesticides and drugs. *Intl J Pest Manag* 44:161–180
- Gressel J (2002) *Molecular biology of weed control*. Taylor & Francis, London
- Gressel J, Segel LA (1978) The paucity of genetic adaptive resistance of plants to herbicides: possible biological reasons and implications. *J Theor Biol* 75:349–371
- Gressel J, Segel LA (1982) Interrelating factors controlling the rate of appearance of resistance: The outlook for the future. In: Le Baron H, Gressel J (eds) *Herbicide resistance in plants*. Wiley, New York, pp 325–347
- GuhaMajumdar M, Baldwin S, Sears BB (2004) Chloroplast mutations induced by 9-aminoacridine hydrochloride are independent of the plastome mutator in *Oenothera*. *Theor Appl Genet* 108:543–549
- Hagemann R (1971) Struktur und funktion der genetischen information in den Plastiden I. Die Bedeutung von Plastiden mutanten und die genetische nomenklatur extranucleärer mutationen. *Biol Zentralblatt* 90:409–418
- Harfe BD, Jinks-Robertson S (2000) Mismatch repair proteins and mitotic genome stability. *Mutat Res* 451:151–167
- Heap IM (1988) Resistance to herbicides in annual ryegrass (*Lolium rigidum*). Ph.D. Thesis, University Waite Agriculture Institute, Adelaide
- Heap IM (2008) International survey of herbicide-resistant weeds. <http://www.weedscience.org>
- Hoffman PD, Leonard JM, Lindberg GE, Bollmann SR, Hays JB (2004) Rapid accumulation of mutations during seed-to-seed propagation of mismatch-repair-defective *Arabidopsis*. *Genes Dev* 18:2676–2685
- Horst JP, Wu TH, Marinus MG (1999) *Escherichia coli* mutator genes. *Trends Microbiol* 7:29–36
- Hughes A (1999) *Adaptive evolution of genes and genomes*. Oxford University Press, Oxford
- Kashkush K, Feldman M, Levy AA (2003) Transcriptional activation of retrotransposons alters the expression of adjacent genes in wheat. *Nat Genet* 33:102–106
- Kovalchuk I, Kovalchuk O, Hohn B (2000) Genome-wide variation of the somatic mutation frequency in transgenic plants. *EMBO J* 19:4431–4438
- Kovalchuk I, Kovalchuk O, Hohn B (2001) Biomonitoring the genotoxicity of environmental factors with transgenic plants. *Trends Plant Sci* 6:306–310
- LeClerc JE, Li B, Payne WL, Cebula TA (1996) High mutation frequencies among *Escherichia coli* and *Salmonella* pathogens. *Science* 274:1208–1211
- LeClerc JE, Paynes WL, Kupchella E, Cebula TA (1998) Detection of mutator subpopulations in *Salmonella typhimurium* LT2 by reversion of *his* alleles. *Mutat Res* 400:89–97
- Lederberg J, Lederberg E (1952) Replicate plating and indirect selection of bacterial mutants. *J Bact* 63:399–406
- Lee TC, Tanaka N, Lamb PW, Gilmer TM, Barrett JC (1988) Induction of gene amplification by arsenic. *Science* 241:79–81
- Letouze A, Gasquez J (2003) Enhanced activity of several herbicide-degrading enzymes: a suggested mechanism responsible for multiple resistance in blackgrass (*Alopecurus myosuroides* Huds.). *Agronomie* 23:601–608
- Macia MD, Blanquer D, Togores B, Sauleda J, Perez JL, Oliver A (2005) Hypermutation is a key factor in development of multiple-antimicrobial resistance in *Pseudomonas aeruginosa* strains causing chronic lung infections. *Antimicrobial Agents Chemo* 49:3382–3386
- Maliszewska-Tkaczyk M, Jonczyk P, Bialoskorska M, Schaaper RM, Fijalkowska IJ (2000) SOS mutator activity: unequal mutagenesis on leading and lagging strands. *Proc Natl Acad Sci USA* 97:12678–12683
- Matic I, Radman M, Taddei F, Picard B, Doit C, Bingen E, Denamur E, Elion J (1997) Highly variable mutation rates in commensal and pathogenic *Escherichia coli*. *Science* 277:1833–1834
- McClintock B (1951) Chromosome organization and genic expression. *Cold Spring Harbor Symp Quant Biol* 16:13–47
- McClintock B (1984) The significance of responses of the genome to challenge. *Science* 226:792–801
- Means JC, Plewa MJ, Gentile JM (1988) Assessment of the mutagenicity of fractions from *s*-triazine-treated *Zea mays*. *Mutat Res* 197:325–336
- Metzgar D, Wills C (2000) Evidence for the adaptive evolution of mutation rates. *Cell* 101:581–584
- Modrich P, Lahue R (1996) Mismatch repair in replication fidelity, genetic recombination and cancer biology. *Ann Rev Biochem* 65:101–133
- Molinier J, Ries G, Zipfel C, Hohn B (2006) Transgenerational memory of stress in plants. *Nature* 442:1046–1049
- Mourad G, White J (1992) The isolation of apparently homoplastic mutants induced by a nuclear recessive gene in *Arabidopsis thaliana*. *Theor Appl Genet* 84:906–914
- Neve P, Powles S (2005) High survival frequencies at low herbicide use rates in populations of *Lolium rigidum* result in rapid evolution of herbicide resistance. *Heredity* 95:485–492
- Oettmeier W (1999) Herbicide resistance and supersensitivity in photosystem II. *Cell Mol Life Sci* 55:1255–1277
- Ottaviano E, Sari Gorla M, Mulcahy DL (1990) Pollen selection: efficiency and monitoring. *Prog Clin Biol Res* 344:575–588
- Otto SP, Michalakis Y (1998) The evolution of recombination in changing environments. *Trends Evol Environ* 13:145–151
- Owen MJ, Walsh MJ, Llewellyn RS, Powles SB (2007) Widespread occurrence of multiple herbicide resistance in Western Australian annual ryegrass (*Lolium rigidum*) populations. *Aust J Agric Res* 58:711–718
- Peck JR, Waxman D (2000) Mutation and sex in a competitive world. *Nature* 406:399–404



- Pedersen S, Simonsen V, Loeschke V (1987) Overlap of gametophytic and sporophytic gene expression in barley. *Theor Appl Genet* 75:200–206
- Plewa MJ (1985) Mutation testing with maize. *Basic Life Sci* 34:323–328
- Preston C (2003) Inheritance and linkage of metabolism-based herbicide cross-resistance in rigid ryegrass (*Lolium rigidum*). *Weed Sci* 51:4–12
- Radman M (1999) Enzymes of evolutionary change. *Nature* 401:866–867
- Ray TB (1982) The mode of action of chlorsulfuron: a new herbicide for cereals. *Pestic Biochem Physiol* 17:10–17
- Redei GP (1973) Extra-chromosomal mutability determined by a nuclear gene locus in *Arabidopsis*. *Mutat Res* 18:149–162
- Redei GP, Plurad SB (1973) Hereditary structural alterations of plastids induced by a nuclear mutator gene in *Arabidopsis*. *Protoplasma* 77:361–380
- Richter J, Powles SB (1993) Pollen expression of herbicide target resistance genes in annual ryegrass (*Lolium rigidum*). *Plant Physiol* 102:1037–1041
- Rios RD, Saione H, Robredo C, Acevedo A, Colombo N, Prina AR (2003) Isolation and molecular characterization of atrazine tolerant barley mutants. *Theor Appl Genet* 106:696–702
- Rosenberg SM, Thulin C, Harris RS (1998) Transient and heritable mutators in adaptive evolution in the lab and in nature. *Genetics* 148:1559–1566
- Sakamoto W, Kondo H, Murata M, Motoyoshi F (1996) Altered mitochondrial gene expression in a maternal distorted leaf mutant of *Arabidopsis* induced by chloroplast mutator. *Plant Cell* 8:1377–1390
- Sandhu AP, Abdelnoor RV, Mackensie SA (2007) Transgenic induction of mitochondrial rearrangements for cytoplasmic male sterility in crop plants. *Proc Natl Acad Sci USA* 104:1766–1770
- Schönfeld M, Yaacoby T, Ben-Yehuda A, Rubin B, Hirschberg J (1987) Triazine resistance in *Phalaris paradoxa* physiological and molecular analyses. *Z Naturforsch* 42c:779–782
- Smith BT, Walker GC (1998) Mutagenesis and more: *umuDC* and the *Escherichia coli* SOS response. *Genetics* 148:1599–1610
- Stambuk S, Radman M (1998) Mechanism and control of interspecies recombination in *Escherichia coli*. I. Mismatch repair, methylation, recombination and replication functions. *Genetics* 150:533–542
- Swoboda P, Gal S, Hohn B, Puchta H (1994) Intrachromosomal homologous recombination in whole plants. *EMBO J* 13:484–489
- Taddei F, Radman M, Maynard-Smit J, Toupance B, Gouyon PH, Godelle B (1997) Role of mutator alleles in adaptive evolution. *Nature* 387:700–702
- Tanksley SD, Zamir D, Rick CM (1981) Evidence for overlap of sporophytic and gametophytic gene expression in *Lycopersicon esculentum*. *Science* 213:453–455
- Tardif FJ, Powles SB (1994) Herbicide multiple-resistance in a *Lolium rigidum* biotype is endowed by multiple mechanisms: isolation of a subset with resistant acetyl-CoA carboxylase. *Physiol Plant* 91:488–494
- Tenaillon O, Toupance B, le Nagard H, Taddei F, Godelle B (1999) Mutators, population size, adaptive landscape and the adaptation of asexual populations of bacteria. *Genetics* 152:485–493
- Travis JMJ, Travis ER (2002) Mutator dynamics in fluctuating environments. *Proc R S London B Biol Sci* 269:591–597
- Warwick SI, Stewart CN Jr (2005) Crops come from wild plants: how domestication, transgenes and linkage together shape fertility. In: Gressel J (ed) *Crop fertility and volunteerism*. CRC Press, Boca Raton, FL
- Young LW, Cross RH, Byun-McKay SA, Wilen RW, Bonham-Smith PC (2005) A high- and low-temperature inducible *Arabidopsis thaliana* HSP101 promoter located in a non-autonomous mutator-like element. *Genome* 48:547–555
- Zahrt TC, Maloy S (1997) Barriers to recombination between closely related bacteria: *MutS* and *RecBCD* inhibit recombination between *Salmonella typhimurium* and *Salmonella typhi*. *Proc Natl Acad Sci USA* 94:9786–9791

## Systems Biology of Abiotic Stress: The Elephant and the Blind Men

Nina V. Fedoroff\*

*Biology Department and Huck Institute of the Life Sciences, Penn State University, University Park, PA 16803, USA*

*The Santa Fe Institute, 1399 Hyde Park Road Santa Fe, NM 87501, USA*

Summary .....	485
I Introduction .....	486
II First Responders: Stomatal Guard Cells.....	487
A Signaling.....	488
B Vesicular Trafficking .....	489
C Cytoskeletal Restructuring .....	490
III A Systems View of the Stress Response: The Elephant .....	490
A The Stomate as a System.....	490
1 Integrating Signal, Structure and Function.....	490
B Stress Beyond the Stomate.....	494
C Wherein Lies the Specificity?.....	495
IV The Future .....	495
Acknowledgements .....	495
References .....	495

### Summary

The study of plant stress responses is fragmented into many separate domains by the type of stress used, the response measured, and the disciplinary perspective of the investigation. Thus, light, salt, drought, and ozone stress are commonly investigated separately. End-point measures vary from changes in stomatal aperture and cellular electrophysiology to signaling and transcriptional changes and, ultimately, cell death. Furthermore, investigations of the same system and end-point are often carried out from very different disciplinary perspectives, such as signaling, cell structure, or expression of genes and protein trafficking. In the present review, I use the old Hindu parable of the elephant and the blind men as a metaphor for the study of the stress response. Taking the well-studied environmental response of guard cells, I first assemble a “parts” list, briefly overviewing the literature on signaling, cytoskeletal changes and vesicular trafficking that mediate changes in the stomatal aperture. I then attempt to synthesize a “systems” view of stomatal responses by integrating the various perspectives. Finally, I briefly explore the relevance of guard cell responses to the more general issues of plant stress responses and comment on future areas of interest.

**Keywords:** cytoskeletal restructuring • reactive oxygen species • systemic acquired resistance • system biology • vesicular trafficking

---

\*Author for Correspondence: e-mail: [nvfl@psu.edu](mailto:nvfl@psu.edu)

## I Introduction

The plant stress response literature is replete with titles asserting that a protein or a particular compound “regulates” a “signaling pathway” that activates the plant’s response to a specific stress of many abiotic stressors (commonly salt, drought, cold, heat, excess light or ozone) or to a biotic stressor (in the form of a particular pathogen – bacterial, viral or fungal). The underlying concept is that there exists a specific set of interacting molecules, primarily proteins, that receives each stress signal somewhere – we often vaguely think that this must be at the cell surface – and transmits it to someplace else commonly a target gene or genes – through a series of intermediaries to give a specific response unique to the stressor. We endeavor to place a given protein “upstream” or “downstream” of another in this signaling pathway on the assumption that the pathway is somehow quite uncomplicated, linear and yes, hierarchical – else what would be the sense of asserting that some component “regulates” the “pathway”? If things don’t fit neatly into a linear pathway, we postulate that a given intermediate acts both “upstream” and “downstream”.

Yet it is increasingly clear that abiotic stressors, such as excess light, salt and ozone, activate the expression of many of the same genes that were identified and viewed as specific responses to infection by pathogens (Mullineaux et al. 2000; Mahalingam et al. 2005; Tosti et al. 2006). So we report the “crosstalk” between signaling pathways, as if these independent, linear pathways – wires, as it were – occasionally got crossed and the signal leaked from one to activate another –

not unlike someone else’s telephone conversation intruding into yours. More recently, the concept of “integrators” has entered literature, suggesting somewhat more explicit points of reconciliation amongst what we still conceptualize as independent, even parallel, linear signaling pathways.

At the cellular level, many of the same ions and small-molecules, ranging from calcium, ROS, nitric oxide and small lipids to salicylic acid, ethylene, ABA and jasmonic acid, are centrally involved in the responses of plant cells to a variety of stresses and pathogens (Howe and Schilmiller 2002; Laxalt and Munnik 2002; Wiermer et al. 2005; Gechev et al. 2006; Grun et al. 2006; Wang 2006). Calcium ions have long been called “second messengers”, but reactive oxygen, nitrogen and sulfur species are also increasingly receiving this designation. Evidence is also rapidly accumulating that hormones can interact directly with multiple proteins, commonly inside the cells, to directly influence their biochemical functions, often without the intervention of second messengers (Dharmasiri et al. 2003, 2005; Razem et al. 2006; Shen et al. 2006). We still designate these targets as “hormone receptors,” but the conventional separation of signal receiver from its transmitter and its target may not exist for some small molecules, traditionally regarded as hormones. Moreover, while some hormone receptors are located in the plasma membrane, others are in internal membranes, such as the endoplasmic reticulum (ER) (Wang et al. 2001b; Chen et al. 2002). Inactive conjugates and esters of hormones were identified some time ago, but evidence that these constitute physiologically important, rapidly mobilizable internal stores is rather recent (Lee et al. 2006).

Responses of plants to both abiotic stressors and pathogens are complicated in time and space. It was first reported more than a decade ago that plants respond to a variety of insults, both biotic and abiotic, themselves by producing a biphasic “oxidative burst,” with a first transient increase in ROS production commencing within minutes of an insult and another some hours later (Levine et al. 1994; Lamb and Dixon 1997). Rapid transient increases in the cytoplasmic concentration of free calcium ions  $[(Ca^{+2})_{cyt}]$  have been known for some time (Trewavas and Gilroy 1991; MacRobbie 1993; Trewavas and Knight 1994), but recent work utilizing new kinds of cellular calcium

---

*Abbreviations:*  $\alpha\beta\gamma$  heterotrimeric G-protein subunits; ABA abscisic acid;  $(Ca^{2+})_{cyt}$  cytosolic calcium concentration; cADPR cyclic ADP ribose; DAG diacylglycerol; ER endoplasmic reticulum; GCR<sub>2</sub> G-protein coupled receptor-2; GFP green fluorescence protein; GPCR G-protein coupled receptor; GSH glutathione; HR hypersensitive response; IP<sub>3</sub> inositol-1,4,5-triphosphate; KATI-GFP K<sup>+</sup> channel-green fluorescent protein; PA phosphatidic acid; PI phosphoinositide; PI<sub>3</sub>P phosphoinositide-3-phosphate; PI<sub>4</sub>P phosphoinositide-4-phosphate; PI<sub>4,5</sub>P<sub>2</sub> phosphoinositide-4,5-bisphosphate; PIP<sub>2</sub> phosphoinositide-4,5-bisphosphate; PIP<sub>3</sub> phosphatidylinositol-3,4,5-triphosphate; PLC phospholipase C; PLD phospholipase D; RAFL RIKEN *Arabidopsis* full-length cDNA; ROS reactive oxygen species; SAA systemic acquired acclimation; SAR systemic acquired resistance

sensors has revealed that calcium signaling has a previously unappreciated temporal and spatial complexity (Allen et al., 1999, 2001; Wood et al., 2000, 2001; Lecourieux et al. 2006; Xiong et al. 2006). The transcriptional response to stress stimuli is also temporally complex, with a regular progression of changes in the expression levels of genes extending from minutes to many hours (Mahalingam et al. 2005). Moreover, signals originating within cells are communicated to neighboring cells both to propagate and to limit the propagation of localized cell death, termed the HR, triggered by pathogens and abiotic stressors. Cell-to-cell and longer-range signals initiate the development of SAR and SAA responses (Mullineaux et al. 2000; Casimiro et al. 2001; Lam et al. 2001; Grant and Lamb 2006). Hence, the emerging picture is somewhat inside-out from the conventional view, with signal perception at multiple sites both at the cell surface and within cells and signals arising from affected cells propagating both to neighboring cells and throughout the plant.

In taking on the assignment of describing the “system biology” of the stress response, I have adopted the metaphor of the elephant and the blind men, an old Hindu parable. Each of us most clearly sees the small set of interactions on which we choose to focus, rarely exploring the relationships among them. Although I cannot promise to deliver the whole elephant, I can suggest some ways to begin connecting the parts. The stress-response literature has focused historically on gene expression changes, which are somewhat removed both spatially and temporally from the initial insults. I will focus on the immediate cellular responses to stimuli because the transcriptional changes must ultimately be grounded in them. The importance of struggling towards a conceptual integration among the various aspects of stress responses lies in how it might influence our future approach to their analysis. It is time to begin viewing the system both at a new level of multidimensional detail and as a whole system to understand what is both common to all stress profiles and what uniquely crafts the plant’s response and adaptation to a specific stressor. This is not just an intellectual exercise, however absorbing, but a task of immense practical importance because it is well known that exposing a plant to stress increases its ability to withstand

subsequent stress of the same or of a different kind (Abel et al. 1986; Delledonne et al. 1998; Sandermann 2000; Logemann and Hahlbrock 2002). These phenomena, termed “priming” and “cross-protection,” have been explored as a means of increasing the ability of crop plants to maintain yield in the face of environmental stress (Iriti et al. 2003; Engelberth et al. 2004). But even priming is not a unitary response and some priming responses appear to have a higher cost in terms of plant productivity than others, underscoring the importance of understanding the operation of the system as a whole (van Hulten et al. 2006).

## II First Responders: Stomatal Guard Cells

The response of stomatal guard cells to abiotic stress is undoubtedly the best-studied plant cellular stress response. Guard cells are also the best-studied biotic stress response system, of course, as well as the best-studied cellular light-, gas- and chemical-sensing system in plants (MacRobbie 1998; Schroeder et al. 2001; Roelfsema and Hedrich 2005). The output of this system is relatively simple and easily measured: stomata open or close by virtue of the swelling or shrinkage of the guard cells. There are dozens of review articles on guard cell function and they can be lumped in three groups by their primary focus on signaling, vesicular trafficking or cytoskeletal re-structuring. These categories overlap to some extent, are vastly disproportionate in the size of the relevant literature, and do not include the contribution of cellular metabolism and sugar uptake (Vavasseur and Raghavendra 2005). Indeed, reviews addressing guard cell signaling outnumber those focused on either of the other areas by more than an order of magnitude. This does not necessarily reflect their eventual importance, but rather reflects both the history of discovery and the existence of appropriate tools and techniques. The availability of genome sequence information, genome-wide gene expression data and large libraries of insertion mutations, together with improving markers and microscopy, are vastly accelerating integration of cellular and molecular studies. But it seems that the tools have, if anything, gotten ahead of the ideas and it is an opportune time to derive a new “systems biology” perspective.



## A Signaling

Stomatal closure can be induced by application of the stress hormone ABA, which is classically regarded as a signaling molecule or first messenger in this system (Schroeder et al. 2001). For a long time, it was assumed that ABA signaling could be represented by a linear signaling pathway, commencing with the binding of ABA to a surface receptor located in the plasma membrane. The general idea is that a signaling molecule (the first messenger) binds to a transmembrane receptor (such as a GPCR), which then activates a transducer (such as a heterotrimeric G-protein), which further activates the production or release of a diffusible second messenger, such as  $\text{Ca}^{2+}$  or ROS, which in turn activates a range of downstream effectors. This concept captures some elements of ABA signaling, but not its totality. There is a plasma-membrane GPCR, encoded by the *Arabidopsis GCR2* gene, that interacts with the  $\alpha$ -subunit of the single heterotrimeric G protein (Liu et al. 2007).

However, it was reported more than a dozen years ago that ABA can act at both the cell surface and inside of the cell (Allan et al. 1994; Anderson et al. 1994; Schwartz et al. 1994). So there appears to be at least two different routes for ABA action, one from the outside and one from the inside of the cell. But at least two other proteins have been identified that might as well directly interact with ABA in guard cells. These are the H-subunit of the chloroplastic Mg-chelatase, reported to be the most abundant ABA-binding protein in cells, and a plasma membrane receptor-like kinase designated RLK1 (Osakabe et al. 2005; Shen et al. 2006). Moreover, stomatal aperture is also influenced by light, humidity and  $\text{CO}_2$ , inputs that impact stomatal dynamics by different molecular routes (Schroeder et al. 2001).

The earliest detectable ABA-induced chemical changes in plant cells are the increases in intracellular calcium [ $(\text{Ca}^{2+})_{\text{cyt}}$ ] and ROS (Orozco-Cardenas et al. 2001; Lecourieux et al. 2006). These have been designated “second messengers” (Lecourieux et al. 2006) according to the criterion that interfering with their production or destroying them enzymatically or with reducing agents abolishes both the increase in  $(\text{Ca}^{2+})_{\text{cyt}}$  and prevents ABA-induced stomatal closure (Zhang et al. 2001). Also, there is evidence that the observed

increase in  $(\text{Ca}^{2+})_{\text{cyt}}$  is necessary for stomata to close, suggesting again that calcium ions act as second messengers (Blatt 2000a; Schroeder et al. 2001). However, there is also evidence that stomata can close without an increase in  $(\text{Ca}^{2+})_{\text{cyt}}$  (Allan et al. 1994; Levchenko et al. 2005; Marten et al. 2007), implying that at the very least, that a calcium transient is not an obligatory feature of the closure mechanism. Efforts to place calcium and ROS in a linear chain of causation as second messengers in ABA signaling are stubbornly resisted by the fact that some studies place ROS firmly upstream of calcium signaling, while others place it downstream (Mori and Schroeder 2004). Also, both elevated external calcium level and external exposure to ROS can induce stomatal closure (McAinsh et al. 1995; Zhang et al. 2001). The changes in  $(\text{Ca}^{2+})_{\text{cyt}}$  observed in guard cells have a temporal pattern, with single peaks (transients) of a characteristic shape and size or with oscillations in a few minutes following a stimulus. These have been called the “calcium signature” and there is a not insignificant cottage industry in interpreting its information content (McAinsh and Hetherington 1998; Clayton et al. 1999; Knight and Knight 2000; Allen et al. 2001; Assmann and Wang 2001; Schroeder et al. 2001). Guard cells also rapidly produce ROS from different sources in a temporal sequences that can itself be regarded as an “ROS signature” (Schroeder et al. 2001; Mahalingam and Fedoroff 2003; Gechev et al. 2006). Strikingly, chloroplasts are the initial site of ROS production in ABA-treated guard cells, followed by cytoplasmic sources (Allan and Fluhr 1997; Zhang et al. 2001). But it has been reported that the ROS produced by plasma membrane-bound NADPH oxidases, which transport electrons across the plasma membrane to generate ROS outside of cells, are required for activation of calcium channels and stomatal closure (Pei et al. 2000; Kwak et al. 2003).

Many other small molecules and signaling proteins are involved in stomatal movements. Phospholipases C and D and the small molecules derived from membrane lipids, such as  $\text{IP}_3$ , PA, DAG, and sphingosine-1-phosphate have been implicated in ABA signaling (Gilroy et al. 1990; Jacob et al. 1999; Coursol et al. 2003; Zalejski et al. 2005). Protein phosphorylation and dephosphorylation are known, as judged by both the ability

of protein kinase and phosphatase inhibitors, as well as mutations in two type 2C protein phosphatase genes (*ABII* and *ABI2*), to interfere with stomatal movements (Schroeder et al. 2001). cADPR also participates in ABA signaling and stomatal closure (Wu et al. 1997; Leckie et al. 1998). Two GPCRs, GCR1 and GCR2, the  $\alpha$  subunit of the heterotrimeric G protein and the small GTPase AtRac1 (Rop6) have been implicated in ABA signaling and guard cell function (Lemichez et al. 2001; Wang et al. 2001a; Pandey and Assmann 2004; Liu et al. 2007).

### B Vesicular Trafficking

Guard cells swell and shrink to alter the size of the stomatal aperture. The substantial increase in guard cell volume during stomatal opening necessitates an increase in surface area that can be as much as 40%, significantly exceeding the membrane elasticity limit of about 3% (Homann 1998; Blatt 2000b; Morris and Homann 2001; Shope et al. 2003; Meckel et al. 2005). Experiments employing fluorescent membrane dyes reveal a continuous slow internalization of membrane material in unstimulated guard cell protoplasts (Kubitscheck et al. 2000). Changes in osmotic pressure trigger rapid variation in membrane area, which has been reported to change by more than 10% in 10 min (Homann and Thiel 1999). The changes in surface area occur by incorporation of membranous material by exocytosis and its retrieval by endocytosis (Homann and Thiel 1999; Kubitscheck et al. 2000; Shope et al. 2003). Guard cells expand both in diameter and in length during stomatal opening (Meckel et al. 2007). Most of the increase in volume can be attributed to cell expansion; however, extension of the tips of guard cells appears to be primarily responsible for the mechanical deformation that increases the size of the stomatal opening (Meckel et al. 2007). Moreover, changes in guard cell volume are accompanied by re-organization of vacuoles. Closed guard cells contain many small vacuoles (Gao et al. 2005). These undergo rapid fusion upon guard cell opening, with a simultaneous increase in the area of the vacuolar membrane (tonoplast) (Gao et al. 2005).

Stomatal opening occurs by changes in turgor pressure driven by the influx of  $K^+$  ions, sugar and anions ( $Cl^-$  and malate) resulting from the

development of an electrical potential by proton pumps ( $H^+$ -ATPases) in the plasma and vacuolar membranes (Schroeder et al. 2001; Roelfsema and Hedrich 2005). The  $H^+$ -ATPases are activated by a decrease in pH and contain a C-terminal autoinhibitory domain (Roelfsema and Hedrich 2005). Stomatal opening is stimulated by both red and blue light (Schroeder et al. 2001; Roelfsema and Hedrich 2005). The plasma-membrane and vacuolar  $H^+$ -ATPases are activated by phosphorylation and binding of 14-3-3 proteins in response to blue light, which is perceived by phototropins (Hentzen et al. 1996; Kinoshita and Shimazaki 1999; Kinoshita et al. 2001; Sakamoto and Briggs 2002; Takemiya et al. 2006). Although phototropins are themselves protein kinases and might be responsible for the direct phosphorylation of the proton pumps, additional regulatory components are suggested by the report that inhibition of type1 protein phosphatases by tautomycin interferes with phosphorylation of the  $H^+$ -ATPase, but not that of the phototropin (Takemiya et al. 2006). Stomatal aperture is also regulated by  $CO_2$ , although the underlying mechanisms are not well understood (Roelfsema and Hedrich 2005). There is evidence that ABA, light and  $CO_2$  responses are linked to some extent and also that they are independent (Vavasseur and Raghavendra 2005).

While little is yet known about the range of mechanisms by which ion channels are regulated, results of studies employing a  $K^+$  channel-green fluorescent protein (KAT1-GFP) fusion have established the existence of membrane patches carrying a higher density of  $K^+$  channel clusters than is characteristic of the plasma membrane as a whole (Hurst et al. 2004; Meckel et al., 2004). The KAT1-GFP fluorescence exhibits a punctate distribution in guard cells, with an intensity greater by two-fold at the tips of the cells than elsewhere, which is consistent with greater membrane turnover at the tips (Meckel et al. 2007). Rapid and reversible changes in guard cell volume are also induced by hypo- and hyperosmotic solutions (Shope et al. 2003). Such changes occur by water uptake and extrusion. These processes also entail changes in surface area of up to 30% by membrane endo- and exocytosis (Shope et al. 2003; Shope and Mott 2006). Agents that promote depolymerization of microtubules, actin filaments and the  $PI_3$  kinase inhibitor wortmannin, all of which affect vesicular

trafficking, were found to interfere either with the expansion or the contraction of the membrane (Shope and Mott 2006).

Evidence that vesicular trafficking is critical to guard cell expansion and contraction is provided by the discovery that disrupting the function of a syntaxin encoded by the tobacco *Nt-SYR1* (*SYP121*) gene blocks ion channel responses to ABA (Leyman et al. 1999). Syntaxins comprise a family of proteins that participate in protein-protein interactions which mediate the vesicle-membrane fusions that are required for the vesicle trafficking of secretory processes and endocytosis (Sutter et al. 2006a). Over-expression of a fragment of this protein disperses plasma membrane KAT1-GFP clusters and results in the apparent retention of the channel in the endoplasmic reticulum (ER) (Sutter et al. 2006b). Similarly, SYP22 is involved in vacuolar fusion (Gao et al. 2005).

### C Cytoskeletal Restructuring

The precise organization of the cytoskeleton, a complex of microtubules and actin filaments, is central both to the development of guard cells and to their function of controlling the stomatal aperture (Galatis and Apostolakos 2004). Many investigations have documented the rapid rearrangement of the cytoskeleton from a form in which the microtubules and actin filaments are in a radial array and extend from the ventral to the dorsal wall of each guard cell in open stomates to a form in which they are shorter and occur in many different orientations in closed stomates (Staiger 2000). The ordered, radially arrayed microtubules and actin filaments rearrange to the more disordered form during ABA-induced stomatal closure, as well as stomatal closure during the light-dark transition (Kim et al. 1995).

Stabilization of actin filaments with phalloidin promotes formation of densely packed radial actin filament arrays and inhibits both the inward  $K^+$  current and ABA-induced stomatal closure (Kim et al. 1995; Hwang et al. 1997). Destabilization of actin filaments with cytochalasin B or D causes the partial opening of closed stomata, promotes light-induced stomatal opening, and increases the inward  $K^+$  current (Kim et al. 1995; Hwang et al. 1997). Similar observations have been made on guard cell microtubules (Fukuda et al. 1998; Huang et al. 2000; Marcus et al. 2001; Lahav et al.

2004). Thus, reorganization of microtubules and actin filaments is closely correlated with changes in stomatal aperture. Although it was originally thought that the fungal toxin fusicoccin, which promotes stomatal opening by activating plasma membrane  $H^+$ -ATPase, uncouples microtubule and actin filament reorganization from stomatal opening (Assmann and Schwartz 1992; Marcus et al. 2001), cytoskeletal changes have been reported in fusicoccin-treated cells (Eun and Lee 2000).

## III A Systems View of the Stress Response: The Elephant

### A The Stomate as a System

The variety of stimuli to which guard cells respond and the multiplicity of molecular components participating in the response seriously defy efforts to construct a satisfying array of conventional linear signaling pathways by incorporating concepts such as “crosstalk” and “integrators.” It is the stomate itself, comprising the guard cell pair that is the “system”, integrating input signals and adjusting cell size and shape. While this may seem like a retreat from molecular rigor to animism, it is actually a first tentative attempt to synthesize the various presently disparate observations on the chemical and structural dynamics of guard cells.

#### 1 Integrating Signal, Structure and Function

ROS and calcium “signals” are both ubiquitous intertwined everywhere in plants and animals. This is a phenomenon that some authors refer to as “cross talk” (Knight and Knight 2001; Mori and Schroeder 2004; Hidalgo 2005; Camello-Almaraz et al. 2006), while others dismiss with the argument that ROS and calcium aren’t really signals, just regulators or switches in the chemical machinery of life (Scrase-Field and Knight 2003; Plieth 2005). But signal and switch may be one and the same. Calcium ions and ROS share several important characteristics: both are extremely toxic to cells, both influence protein structure and activity, both act rather indiscriminately over short distances (albeit for different reasons) and there are multiple sources of each,

both inside of plant cells and in the apoplastic space (Gechev et al. 2006; Lecourieux et al. 2006).

Life evolved in a reducing atmosphere and adaptation to an increasingly oxidizing environment did not alter its basic biochemistry. Rather, it led to the evolution of multiple mechanisms to maintain a reducing intracellular environment (Sitia and Molteni 2004). Life is powered by the conversion of solar energy to chemical energy, its storage through photosynthesis and extraction through oxidative phosphorylation. In all organisms, and especially plants, this entails the dangers of unbalanced electron flow and the possibility of generating ROS, which are partially reduced oxygen molecules. The cellular mechanisms that protect the cell from oxidation of proteins and nucleic acids by these strong oxidants include the maintenance of high intracellular concentrations of low molecular weight redox couples, enzymes that rapidly reduce ROS to water, and protective mechanisms such as glutathionylation of proteins, activation of chaperones and protein disulfide isomerases, as well as nucleic acid repair mechanisms (Sitia and Molteni 2004). The existence of rapid chemical and enzymatic mechanisms for quenching ROS, in turn, makes it possible to make use of them as short-range signals. Moreover, the oxidation and reduction of disulfide bonds within and between proteins is not only essential for their correct folding, but is also as fundamental a regulatory mechanism as protein phosphorylation (Paget and Buttner 2003; Fedoroff 2006).

It has been suggested that efficient calcium ion sequestration is essential in view of the central role of phosphate in both energy metabolism and regulating protein structure, simply because of the insolubility of calcium phosphate (Sanders et al. 1999). Plant cells maintain an internal free calcium concentration about 1–2 orders of magnitude lower than the extracellular calcium concentration, both by the extrusion of calcium and its rapid sequestration by the many calcium-binding proteins in cells (Gilroy et al. 1990; Sanders et al. 1999). As in the case of ROS, these mechanisms make it possible for rapid, transient spikes in the concentration of free calcium to serve as protein and enzyme activators and inactivators, both directly and through interaction with calcium-binding proteins. Oscillations that bring the  $(Ca^{2+})_{\text{cyt}}$  in guard cells above 0.5 mM trigger

guard cell closure (Gilroy et al. 1990; McAinsh et al. 1992, 1995).

The prevailing view is that calcium is actively sequestered by calcium pumps in “internal stores” comprising vacuoles and the endoplasmic reticulum and that calcium transients are generated by the release of calcium from these internal stores, which in turn, triggers its uptake through calcium channels in the plasma membrane (Penner and Fleig 2004; Putney 2007). A radically different view holds that the main calcium-sequestering protein in the cell is filamentous actin (F-actin) and that actin depolymerization transiently releases free calcium, which is then rapidly bound by ATP-G-actin (which has a high calcium affinity), and reincorporated into F-actin (Lange and Brandt 1996; Lange and Gartzke 2006). The notion that F-actin is the major calcium store is a particularly attractive hypothesis for plants cells whose cortical ER has an actin backbone (Boevink et al. 1998). However, it is increasingly recognized that ER resident proteins, such as calreticulin and calsequestrin, with an extremely high calcium-binding capacity, also participate actively in the sequestration and release of calcium (Beard et al. 2004; Persson et al. 2004).

A cytoskeletal network of both actin filaments and microtubules comprises the heart of the highly dynamic cortical ER of plant cells, including stomata (Hepler et al. 1990; Boevink et al. 1998). Actin depolymerization and reorganization underlie all the shape changes that guard cells undergo in response to prevailing external conditions (Fig. 1). Virtually every type of stimulus that alters the stomatal aperture triggers actin depolymerization and cytoskeletal restructuring (Kim et al. 1995; Hwang et al. 1997; Eun and Lee 2000; Hwang and Lee 2001; Marcus et al. 2001; Lahav et al. 2004; Xiao et al. 2004). Assuming that F-actin and other calcium-binding proteins of the cortical ER are the calcium stores, then calcium spikes reflect the transient release of  $Ca^{2+}$  from ER proteins and the actin depolymerization that initiate the changes in stomatal aperture (Fig. 1). The release of calcium, as noted earlier, transiently increases the  $[Ca^{2+}]_{\text{cyt}}$ , activating a variety of enzymes, including the calcium-dependent membrane-bound NADPH oxidase, as well as the further influx of calcium (Schroeder et al. 2001).



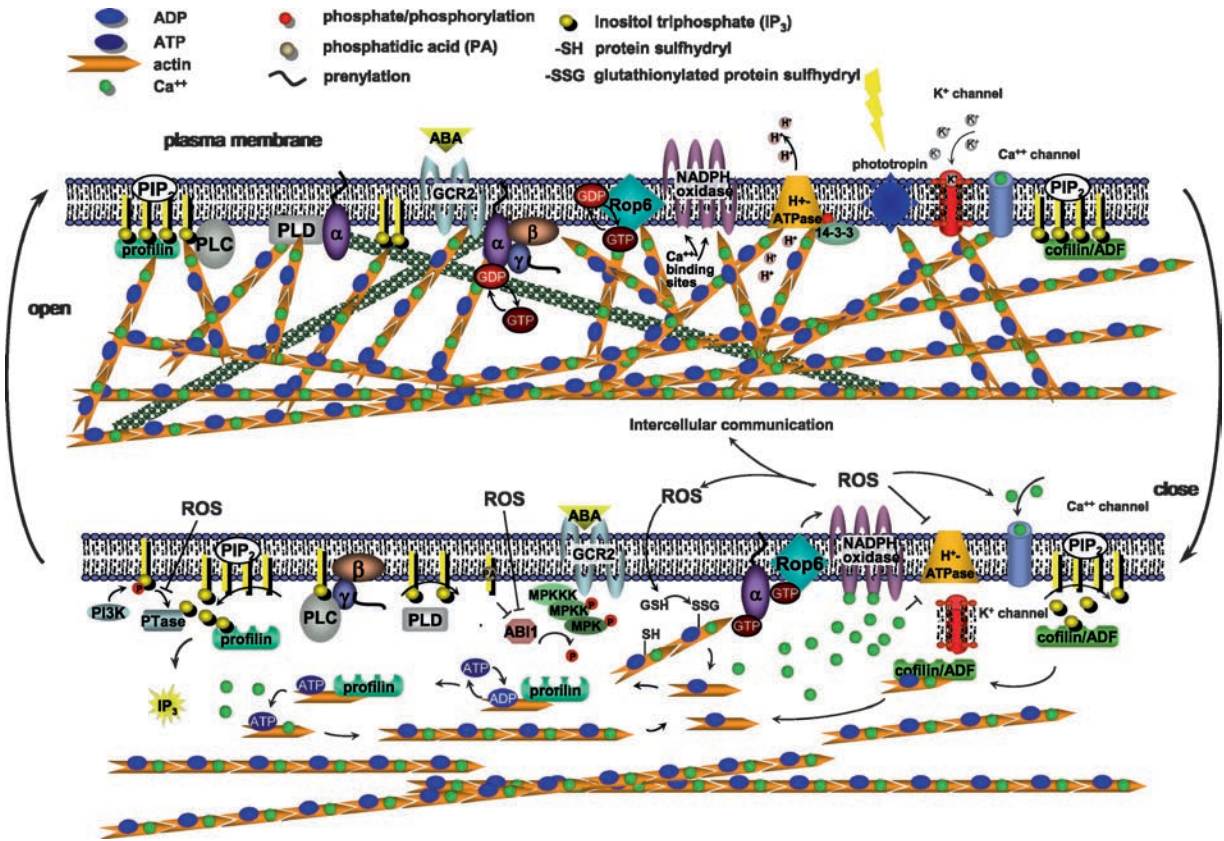

Fig. 1. A diagrammatic representation of some of the changes known to occur in the structural and signaling component during stomatal movements, as described in the text. Abbreviations (used in the figure): ABA, abscisic acid;  $\alpha\beta\gamma$ , heterotrimeric G-protein subunits; GCR2, G-protein coupled receptor 2; PIP<sub>2</sub>, phosphatidylinositol 4,5 bisphosphate; GSH, glutathione; MPK, MAP kinase; MPKK, MAPK kinase; MPKKK, MAPKK kinase; PLC and PLD, phospholipases C and D; ROS, reactive oxygen species [See Color Plate 13, Fig. 20].

Similarly, ROS are likely to affect both cytoskeletal organization and enzymatic activity. Only one route of ROS production is represented in Fig. 1, which is initiated by the perception of ABA at the cell membrane, stimulating dissociation of the heterotrimeric G protein. Activated  $G\alpha$ , in turn, is believed to activate the small GTPase Rop6 which further activates the membrane-bound NADPH oxidases, primarily AtrbohF and AtrbohD in guard cells (Kwak et al. 2003). But it is also known that ROS are initially and rapidly elicited from guard cell chloroplasts upon ABA stimulation, as well as ozone exposure (Zhang et al. 2001; Joo et al. 2005). There are additional intra- and extra-cellular sources of ROS that may well be triggered by other environmental stimuli and the most stable ROS, H<sub>2</sub>O<sub>2</sub>, is membrane permeable (Bolwell et al. 2002). Thus, ROS arising from either external or internal sources are likely

to exert an effect in the vicinity of the cell surface.

ROS stimulate the glutathionylation of many proteins, particularly actin, in both animal and plant cells (Giustarini et al. 2004; Dixon et al. 2005). Actin glutathionylation has been shown to be essential for actin polymerization and reorganization in response to growth and chemotactic factors in animal cells (Wang et al. 2003; Fiaschi et al. 2006). Specifically, glutathionylation of sulfhydryl group of the single superficial cysteine residue (Cys<sup>374</sup>) of actin interferes with the disassembly of the actinomyosin complex that initiates cytoskeletal reorganization (Fiaschi et al. 2006). The catalytic subunit of the mammalian NADPH oxidase, designated Nox2, is associated with the ER and is transported to the membrane at the leading edge of migrating epithelial cells, where it interacts with actin and an actin-binding

scaffold protein designated IQGAP1 (Ikeda et al. 2005). While such studies have not yet been done in plants, plant cells contain myosins, at least some of which are thought to play an F-actin stabilizing role and participate in organelle movement (Volkman et al. 2003; Lee and Liu 2004; Abu-Abied et al. 2006; Holweg 2007). There are likely to be additional F-actin-stabilizing proteins and in view of the fact that ROS production and cytoskeletal restructuring are required for stomatal closure, it appears a quite reasonable conjecture that ROS promote actin reorganization in guard cells of plants, as they do in animal cells (Fig. 1).

ROS also impact enzymatic activity directly through oxidation of sulfhydryl residues and promotion of protein disulfide bond formation (Finkel 2001; Dietz 2003; Fedoroff 2006). Protein phosphatases contain readily oxidizable cysteine residues in their active sites and are therefore likely to be immediate targets of ROS regulation (Xu et al. 2002). It is well established that ABA and ROS activate stress MAP kinases (Mishra et al. 2006b). Likely targets include the protein phosphatases encoded by the *ABI1* and *ABI2* genes, as well as the MAP kinase phosphatases (Meinhard and Grill 2001; Ulm et al., 2001, 2002; Meinhard et al. 2002; Meskiene et al. 2003). Thus activation of ROS production and changes in  $[Ca^{2+}]_{cyt}$  are intimately interconnected with cytoskeletal reorganization. Moreover, as illustrated in the Fig. 22.1, they may well feed-back on each other, since the NADPH oxidase is activated by calcium. It has also been suggested that  $Ca^{2+}$  channels are activated by ROS (Pei et al. 2000), although the effect of ROS on cytoskeletal structure was not addressed in these experiments.

Moreover, vesicular trafficking in plant cells is inseparable from the cytoskeletal network, since F-actin filaments and microtubules are integral to the structure and function of the ER (Boevink et al. 1998; Brandizzi et al. 2003). The exocytotic and endocytotic membrane trafficking that are required for the constant adjustments in membrane surface area are sensitive to agents that interfere with microtubule and actin filament dynamics (Shope and Mott 2006). It has been reported in mammalian cells that both actin depolymerization and polymerization are necessary for exocytosis (Malacombe et al. 2006). It is thought that actin depolymerization enhances the

ability of secretory granules to reach the plasma membrane, while actin polymerization provides a motive force that accelerates the membrane fusion process (Malacombe et al. 2006).

The recognition that  $K^+$  channels are regulated by altering their numbers through the insertion of membranous packets containing multiple copies of them, as well as by  $Ca^{2+}$ -dependent activation of their phosphorylation, identifies the link between cytoskeleton and  $K^+$  currents (Hurst et al. 2004; Sutter et al. 2006b). In a variety of animal cells, most or all membrane proteins are clustered in cholesterol-rich domains, designated islands, separated by protein-free, cholesterol-poor membrane domains (Lillemeier et al. 2006). The protein-rich islands include previously characterized lipid rafts, and different proteins form sub-clusters within them. The protein islands are connected to the actin cytoskeleton and can be dispersed by latrunculin, an actin-depolymerizing agent (Lillemeier et al. 2006). Recent observations on KAT1-GFP fusions are consistent with a similar organization of plant membranes, revealing the existence of KAT1-rich membrane clusters (Hurst et al. 2004; Meckel et al., 2005; Sutter et al. 2006b) firmly anchored in the plasma membrane (M. Blatt, personal communication).

Although it is known that Golgi bodies travel rapidly along the cytoskeletal network (Boevink et al. 1998; daSilva et al. 2004), there may be other protein-lipid complexes that travel the same cytoskeletal highway from ER to cell surface. A possibility yet to be explored is that  $Ca^{2+}$  currents are regulated by altering  $Ca^{2+}$  channel densities in the plasma membrane by a similar secretory mechanism. In addition to their role in supporting the secretory trafficking required to expand membranes and to add ion channels, it is also possible that the cytoskeletal restructuring observed during stomatal opening serves a structural role. The microtubules and actin filaments form highly distinctive radial arrays when stomates open (Kim et al. 1995; Fukuda et al. 1998; Lahav et al. 2004). Also, guard cells are encircled by radial arrays of cellulose microfibrils (Lahav et al. 2004). There is growing evidence that cellulose synthase complexes are mobile and critically oriented by microtubules (Smith and Oppenheimer 2005; Somerville 2006; Chu et al. 2007; DeBolt et al. 2007). As turgor pressure increases with the influx of ions and water during guard

cell opening, it is likely that the arrays limit the radial expansion of the cells by guiding cellulose deposition. The observation that blue light specifically promotes the reconfiguration of guard cell microtubules suggests a connection between phototropins and microtubule-associated proteins (Lahav et al. 2004).

It is increasingly recognized that membrane phospholipids are essential elements of plant cellular signaling (Laxalt and Munnik 2002).  $PI_3P$ , and  $PI_4P$  and  $PIP_2$  have all been implicated in stomatal movements, as have PLC, PLD and PI3 kinase (MacRobbie 1998; Jacob et al. 1999; Staxen et al. 1999; Jung et al. 2002; Park et al. 2003; G. Mishra et al. 2006a). As shown in Fig. 1, recent work has revealed that  $PLD\alpha 1$ -derived PA binds to, inhibits and membrane-sequesters the ABI1 protein phosphatase 2C to promote stomatal closure (Mishra et al. 2006a). An interaction between  $PLD\alpha 1$  and the  $G\alpha$  subunit of the heterotrimeric G protein inhibits opening of closed stomata by inhibiting PLD activity and stimulating the GTPase activity of  $G\alpha$ . (Mishra et al. 2006a). It has also been reported that PI3 kinase inhibitors prevent stomatal closing and the production of ROS (Park et al. 2003).

Although little is as yet known about the detailed mechanisms by which they exert their effects on stomatal aperture,  $PI_3P$ ,  $PI_4P$  and  $PI_{4,5}P_2$ , appear to be located in different cell compartments (Jung et al. 2002; Vermeer et al. 2006). Membrane phospholipids target many signaling and cytoskeletal proteins to the plasma membrane and there is recent evidence that such targeting can be attributed to both polybasic clusters in the targeted proteins and lipid modifications (Heo et al. 2006). The membrane association of small GTPases and heterotrimeric G proteins is likely to be regulated by the specificity of their phospholipid interactions, as well as the activity of phospholipases. Many actin-binding proteins that participate in cytoskeletal remodeling are membrane-tethered and maintained in an inactive form by binding to membrane phospholipids, particularly  $PIP_2$  and  $PIP_3$  (Nebl et al. 2000; Hilpela et al. 2004; Huang et al. 2006). Both the spatial localization of the phospholipids and the localized activation of lipid kinases, phosphatases and phospholipases can trigger actin remodeling by the differential release and sequestration of actin-remodeling proteins from the membrane (Toker 1998). Plants contain

both profilin and cofilin/ADF, whose mammalian counterparts bind to and are regulated by  $PIP_2$  and  $PIP_3$  (McCurdy et al. 2001; Skare and Karlsson 2002; Feng et al. 2006; Gorbatyuk et al. 2006). Also, there is substantial evidence that  $Ca^{2+}$  channels are reciprocally regulated by membrane phospholipids  $PIP_2$  and  $PIP_3$  and the calcium-binding protein calmodulin (Kwon et al. 2007), a mechanism similar to that reported for cofilin (Gorbatyuk et al. 2006). Thus, the local activation of phospholipid-modifying enzymes, such as phospholipid kinases and phosphatases, as well as phospholipases, can both activate cytoskeletal restructuring and affect ion movements across the membrane (Tall et al. 2000).

### B Stress Beyond the Stomate

To what extent are the signaling and cytoskeletal/vesicular restructuring observed in stomata representative of cellular stress responses in general? Perhaps because guard cells respond to changing environmental conditions rapidly, visibly and reversibly, immediate structural and cellular changes have dominated their study, with relatively little attention devoted to transcriptional changes (Leonhardt et al. 2004). By contrast, the literature on abiotic stress responses is dominated by the analysis of gene expression changes, increasingly relying on cDNA and oligonucleotide microarray technology in recent years (Seki et al. 2004; Kilian et al. 2007). Another obvious difference is that guard cell studies are generally investigated within a range of environmental conditions under which they are reversible, while responses to pathogens and other stresses are often investigated near or beyond the limits of plants' ability to adapt, as judged by either local cell death or tissue collapse.

Nonetheless, transient  $Ca^{2+}$  spikes and the production of ROS are common early components of both biotic and abiotic stress responses in plants (Price et al. 1994; Doke et al. 1996; Knight et al. 1996, 1997; Takahashi et al. 1997; Lecourieux et al. 2002; Mahalingam and Fedoroff 2003; Torres and Dangl 2005; Lecourieux et al. 2006). Phospholipid signaling is a well-established early plant stress response and there is a direct connection between cytoskeletal reorganization and activation of enzymes that modify membrane phospholipids (Munnik 2001; Laxalt and Munnik



2002; Dhonukshe et al. 2003; Testerink et al. 2004; Wang 2005; Williams et al. 2005; Huang et al. 2006). Cytoskeletal rearrangements have been reported in response to pathogens and pathogen-derived toxins, as well as a variety of abiotic stresses, including cold, excess light, and osmotic stress (Gross et al. 1993; Aon et al. 2000; Staiger 2000; Binet et al. 2001; Lipka and Panstruga 2005; Komis et al. 2006; Shoji et al. 2006; Yuan et al. 2006; D'Angeli and Altamura 2007). Also, upregulation of secretory process and vesicular trafficking, are components of both biotic and abiotic stress responses (Schmelzer 2002; Collins et al. 2003; Wick et al. 2003; Takemoto and Hardham 2004; Lipka and Panstruga 2005; Wang et al. 2005).

### C Wherein Lies the Specificity?

But why is the response of a guard cell different from that of an epidermal cell or a mesophyll cell? And how does common cellular machinery develop a response that is unique and appropriate for a given stress? The answers to such questions are not yet available at a satisfying level of granularity, but there are some generalizations. Plant cells are highly specialized, yet remarkably flexible in their developmental fates. They acquire and maintain their structural and physiological identities by virtue of constant chemical communications among cells within the plant (Dolan and Okada 1999; Golz 2006; Sieburth and Deyholos 2006; Anastasiou and Lenhard 2007). Many plant cells, including guard cells of some plants, can regenerate into complete plants (Hall et al. 1996). The mechanisms that underlie the development of a plant from a single cell, be it a vegetative cell or a zygote, are just beginning to be explicated, as are the mechanisms underlying the regeneration and maintenance of specialized cell types (Willemsen and Scheres 2004; J.Xu et al. 2006; Anastasiou and Lenhard 2007).

## IV The Future

There are many challenges for future research in understanding how plants elaborate appropriate adaptations to environmental extremes. Information about sensors and how they trigger cellular responses is still relatively meager (Albrecht

et al. 2003; Samaj et al. 2004; Zhu et al. 2007). The connections between signaling relays, such as stress-activated MAP kinase cascades, and transcription factors is as yet little explored (Cheong et al. 2003; Ahlfors et al. 2004). It has been reported that the stress-activated transcriptional co-factor NPR1 is maintained in a multimeric, disulfide-bonded cytoplasmic complex in unstressed cells and activated by reduction to monomeric form and translocation to the nucleus, but little is known about the requisite cellular and molecular changes that underlie its mobilization (Mou et al. 2003; Rochon et al. 2006). It is known that the small GTPases, designated ROPs, in plants are involved in both activating ROS production and in stress-mediated cytoskeletal changes (Lemichez et al. 2001; Nibau et al. 2006), but little is known about how such changes affect gene expression. Finally, very little is known about the spatial localization of stress signals and signaling molecules within plant cells, although there is growing evidence that such spatial localization is central to how plant cells are structured in development (Fu et al. 2005; Hwang et al. 2005).

## Acknowledgements

This work was supported by the Willaman Professorship Endowment Fund

## References

- Abel PP, Nelson RS, De B, Hoffmann N, Rogers SG, Fraley RT, Beachy RN (1986) Delay of disease development in transgenic plants that express the tobacco mosaic virus coat protein gene. *Science* 232:738–744
- Abu-Abied M, Golomb L, Belausov E, Huang S, Geiger B, Kam Z, Staiger CJ, Sadot E (2006) Identification of plant cytoskeleton-interacting proteins by screening for actin stress fiber association in mammalian fibroblasts. *Plant J* 48:367–379
- Ahlfors R, Macioszek V, Rudd J, Brosche M, Schlichting R, Scheel D, Kangasjarvi J (2004) Stress hormone-independent activation and nuclear translocation of mitogen activated protein kinases in *Arabidopsis thaliana* during ozone exposure. *Plant J* 40:512–522
- Albrecht V, Weinl S, Blazevic D, D'Angelo C, Batistic O, Kolukisaoglu U, Bock R, Schulz B, Harter K, Kudla J (2003) The calcium sensor CBL1 integrates plant responses to abiotic stresses. *Plant J* 36:457–470



- Allan AC, Fluhr R (1997) Two distinct sources of elicited Reactive Oxygen Species in tobacco epidermal cells. *Plant Cell* 9:1559–1572
- Allan AC, Fricker MD, Ward JL, Beale MH, Trewavas AJ (1994) Two transduction pathways mediate rapid effects of abscisic acid in *Commelina* guard cells. *Plant Cell* 6:1319–1328
- Allen GJ, Kwak JM, Chu SP, Llopis J, Tsien RY, Harper JF, Schroeder JI (1999) Cameleon calcium indicator reports cytoplasmic calcium dynamics in *Arabidopsis* guard cells. *Plant J* 19:735–747
- Allen GJ, Chu SP, Harrington CL, Schumacher K, Hoffmann T, Tang YY, Grill E, Schroeder JI (2001) A defined range of guard cell calcium oscillation parameters encodes stomatal movements. *Nature* 411:1053–1057
- Anastasiou E, Lenhard M (2007) Growing up to one's standard. *Curr Opin Plant Biol* 10:63–69
- Anderson BE, Ward JM, Schroeder JI (1994) Evidence for an extracellular reception site for abscisic acid in *Commelina* guard cells. *Plant Physiol* 104:1177–1183
- Aon MA, Cortassa S, Gomez Casati DF, Iglesias AA (2000) Effects of stress on cellular infrastructure and metabolic organization in plant cells. *Int Rev Cytol* 194:239–273
- Assmann SM, Schwartz A (1992) Synergistic effect of light and fusicoccin on stomatal opening: epidermal peel and patch clamp experiments. *Plant Physiol* 98:1349–1355
- Assmann SM, Wang XQ (2001) From milliseconds to millions of years: guard cells and environmental responses. *Curr Opin Plant Biol* 4:421–428
- Beard NA, Laver DR, Dulhunty AF (2004) Calsequestrin and the calcium release channel of skeletal and cardiac muscle. *Progr Biophys Molec Biol* 85:33–69
- Binet M, Humbert C, Lecourieux D, Vantard M, Pugin A (2001) Disruption of microtubular cytoskeleton induced by cryptogin, an elicitor of Hypersensitive Response in tobacco cells. *Plant Physiol* 125:564–572
- Blatt MR (2000a) Ca<sup>2+</sup> signalling and control of guard-cell volume in stomatal movements. *Curr Opin Plant Biol* 3:196–204
- Blatt MR (2000b) Cellular signaling and volume control in stomatal movements in plants. *Annu Rev Cell Devel Biol* 16:221–241
- Boevink P, Oparka K, Santa Cruz S, Martin B, Betteridge A, Hawes C (1998) Stacks on tracks: the plant Golgi apparatus traffics on an actin/ER network. *Plant J* 15:441–447
- Bolwell GP, Bindschedler LV, Blee KA, Butt VS, Davies DR, Gardner SL, Gerrish C, Minibayeva F (2002) The apoplastic oxidative burst in response to biotic stress in plants: a three-component system. *J Exp Botany* 53:1367–1376
- Brandizzi F, Saint-Jore C, Moore I, Hawes C (2003) The relationship between endomembranes and the plant cytoskeleton. *Cell Biol Int* 27:177–179
- Camello-Almaraz C, Gomez-Pinilla PJ, Pozo MJ, Camello PJ (2006) Mitochondrial Reactive Oxygen Species and Ca<sup>2+</sup> signaling. *Am J Physiol Cell Physiol* 291:C1082–1088
- Casimiro I, Marchant A, Bhalerao RP, Beekman T, Dhooge S, Swarup R, Graham N, Inze D, Sandberg G, Casero PJ, Bennett M (2001) Auxin transport promotes *Arabidopsis* lateral root initiation. *Plant Cell* 13:843–852
- Chen YF, Randlett MD, Findell JL, Schaller GE (2002) Localization of the Ethylene Receptor ETR1 to the Endoplasmic Reticulum of *Arabidopsis*. *J Biol Chem* 277:19861–19866
- Cheong YH, Moon BC, Kim JK, Kim CY, Kim MC, Kim IH, Park CY, Kim JC, Park BO, Koo SC, Yoon HW, Chung WS, Lim CO, Lee SY, Cho MJ (2003) BWMK1, a rice mitogen-activated protein kinase, locates in the nucleus and mediates pathogenesis-related gene expression by activation of a transcription factor. *Plant Physiol* 132:1961–1972
- Chu Z, Chen H, Zhang Y, Zhang Z, Zheng N, Yin B, Yan H, Zhu L, Zhao X, Yuan M, Zhang X, Xie Q (2007) Knock-out of the AtCESA2 gene affects microtubule orientation and causes abnormal cell expansion in *Arabidopsis*. *Plant Physiol* 143:213–224
- Clayton H, Knight MR, Knight H, McAinsh MR, Hetherington AM (1999) Dissection of the ozone-induced calcium signature. *Plant J* 17:575–579
- Collins NC, Thordal-Christensen H, Lipka V, Bau S, Kombrink E, Qiu JL, Huckelhoven R, Stein M, Freialdenhoven A, Somerville SC, Schulze-Lefert P (2003) SNARE-protein-mediated disease resistance at the plant cell wall. *Nature* 425:973–977
- Coursol S, Fan LM, Le Stunff H, Spiegel S, Gilroy S, Assmann SM (2003) Sphingolipid signalling in *Arabidopsis* guard cells involves heterotrimeric G proteins. *Nature* 423:651–654
- D'Angeli S, Altamura MM (2007) Osmotin induces cold protection in olive trees by affecting Programmed Cell Death and cytoskeleton organization. *Planta* 225:1147–1163
- daSilva LLP, Snapp EL, Denecke J, Lippincott-Schwartz J, Hawes C, Brandizzi F (2004) Endoplasmic Reticulum export sites and Golgi bodies behave as single mobile secretory units in plant cells. *Plant Cell* 16:1753–1771
- DeBolt S, Gutierrez R, Ehrhardt DW, Melo CV, Ross L, Cutler SR, Somerville C, Bonetta D (2007) Morlin, an inhibitor of cortical microtubule dynamics and cellulose synthase movement. *Proc Natl Acad Sci USA* 104:5854–5859
- Delledonne M, Xia Y, Dixon RA, Lamb C (1998) Nitric oxide functions as a signal in plant disease resistance. *Nature* 394:585–588
- Dharmasiri N, Dharmasiri S, Jones AM, Estelle M (2003) Auxin action in a cell-free system. *Curr Biol* 13:1418–1422
- Dharmasiri N, Dharmasiri S, Estelle M (2005) The F-box protein TIR1 is an auxin receptor. *Nature* 435:441–445
- Dhonukshe P, Laxalt AM, Goedhart J, Gadella TW, Munnik T (2003) Phospholipase D activation correlates with microtubule reorganization in living plant cells. *Plant Cell* 15:2666–2679
- Dietz KJ (2003) Redox control, redox signaling and redox homeostasis in plant cells. *Int Rev Cytol* 228:141–193

- Dixon DP, Skipsey M, Grundy NM, Edwards R (2005) Stress-induced protein S-glutathionylation in *Arabidopsis*. *Plant Physiol* 138:2233–2244
- Doke N, Miura Y, Sanchez LM, Park HJ, Noritake T, Yoshioka H, Kawakita K (1996) The oxidative burst protects plants against pathogen attack: mechanism and role as an emergency signal for plant bio-defence. *Gene* 179:45–51
- Dolan L, Okada K (1999) Signaling in cell type specification. *Seminars Cell Dev Biol* 10:149–156
- Engelberth J, Alborn HT, Schmelz EA, Tumlinson JH (2004) Airborne signals prime plants against insect herbivore attack. *Proc Natl Acad Sci USA* 101:1781–1785
- Eun SO, Lee Y (2000) Stomatal opening by fusicoccin is accompanied by depolymerization of actin filaments in guard cells. *Planta* 210:1014–1017
- Fedoroff N (2006) Redox regulatory mechanisms in cellular stress responses. *Ann Bot* 98:289–300
- Feng Y, Liu Q, Xue Q (2006) Comparative study of rice and *Arabidopsis* actin-depolymerizing factors gene families. *J Plant Physiol* 163:69–79
- Fiaschi T, Cozzi G, Raugei G, Formigli L, Ramponi G, Chiarugi P (2006) Redox regulation of beta-actin during integrin-mediated cell adhesion. *J Biol Chem* 281:22983–22991
- Finkel T (2001) Reactive oxygen species and signal transduction. *IUBMB Life* 52:3–6
- Fu Y, Gu Y, Zheng Z, Wasteneys G, Yang Z (2005) *Arabidopsis* interdigitating cell growth requires two antagonistic pathways with opposing action on cell morphogenesis. *Cell* 120:687–700
- Fukuda M, Hasezawa S, Asai N, Nakajima N, Kondo N (1998) Dynamic organization of microtubules in guard cells of *Vicia faba* L. with diurnal cycle. *Plant Cell Physiol* 39:80–86
- Galatis B, Apostolakis (2004) The role of the cytoskeleton in the morphogenesis and function of stomatal complexes. *New Phytol* 161:613–639
- Gao XQ, Li CG, Wei PC, Zhang XY, Chen J, Wang XC (2005) The dynamic changes of tonoplasts in guard cells are important for stomatal movement in *Vicia faba*. *Plant Physiol* 139:1207–1216
- Gechev TS, Van Breusegem F, Stone JM, Denev I, Laloi C (2006) Reactive oxygen species as signals that modulate plant stress responses and programmed cell death. *Bioessays* 28:1091–1101
- Gilroy S, Read ND, Trewavas AJ (1990) Elevation of cytoplasmic calcium by caged calcium or caged inositol triphosphate initiates stomatal closure. *Nature* 346:769–771
- Giustarini D, Rossi R, Milzani A, Colombo R, Dalle-Donne I (2004) S-glutathionylation: from redox regulation of protein functions to human diseases. *J Cellular Molec Med* 8:201–212
- Golz JF (2006) Signalling between the shoot apical meristem and developing lateral organs. *Plant Mol Biol* 60:889–903
- Gorbatyuk VY, Nosworthy NJ, Robson SA, Bains NP, Maciejewski MW, Dos Remedios CG, King GF (2006) Mapping the phosphoinositide-binding site on chick cofilin explains how PIP2 regulates the cofilin-actin interaction. *Mol Cell* 24:511–522
- Grant M, Lamb C (2006) Systemic immunity. *Curr Opin Plant Biol* 9:414–420
- Gross P, Julius C, Schmelzer E, Hahlbrock K (1993) Translocation of cytoplasm and nucleus to fungal penetration sites is associated with depolymerization of microtubules and defence gene activation in infected, cultured parsley cells. *EMBO J* 12:1735–1744
- Grun S, Lindermayr C, Sell S, Durner J (2006) Nitric oxide and gene regulation in plants. *J Exp Botany* 57:507–516
- Hall RD, Riksen-Bruinsma T, Weyens G, Lefebvre M, Dunwell JM, Krens FA (1996) Stomatal guard cells are totipotent. *Plant Physiol* 112:889–892
- Hentzen AE, Smart LB, Wimmers LE, Fang HH, Schroeder JI, Bennett AB (1996) Two plasma membrane H<sup>+</sup>-ATPase genes expressed in guard cells of *Vicia faba* are also expressed throughout the plant. *Plant Cell Physiol* 37:650–659
- Heo WD, Inoue T, Park WS, Kim ML, Park BO, Wandless TJ, Meyer T (2006) PI(3, 4, 5)P<sub>3</sub> and PI(4, 5)P<sub>2</sub> lipids target proteins with polybasic clusters to the plasma membrane. *Science* 314:1458–1461
- Hepler PK, Palevitz BA, Lancelle SA, McCauley MM, Lichtscheidl I (1990) Cortical endoplasmic reticulum in plants. *J Cell Sci* 96:355–373
- Hidalgo C (2005) Cross talk between Ca<sup>2+</sup> and redox signalling cascades in muscle and neurons through the combined activation of ryanodine receptors/Ca<sup>2+</sup> release channels. *Philos Trans R Soc Lond B Biol Sci* 360:2237–2246
- Hilpela P, Vartiainen MK, Lappalainen P (2004) Regulation of the actin cytoskeleton by PI(4, 5)P<sub>2</sub> and PI(3, 4, 5)P<sub>3</sub>. *Curr Topics Microbiol Immunol* 282:117–163
- Holweg CL (2007) Living markers for actin block myosin-dependent motility of plant organelles and auxin. *Cell Motility Cytoskeleton* 64:69–81
- Homann U (1998) Fusion and fission of plasma-membrane material accommodates for osmotically induced changes in the surface area of guard-cell protoplasts. *Planta* 206:329–333
- Homann U, Thiel G (1999) Unitary exocytotic and endocytotic events in guard-cell protoplasts during osmotically driven volume changes. *FEBS Lett.* 460:495–499
- Howe GA, Schillmiller AL (2002) Oxylipin metabolism in response to stress. *Curr Opin Plant Biol* 5:230–236
- Huang RF, Wang XC, Lou CH (2000) Cytoskeletal inhibitors suppress the stomatal opening of *Vicia faba* L. induced by fusicoccin and IAA. *Plant Sci* 156:65–71
- Huang S, Gao L, Blanchoin L, Staiger CJ (2006) Heterodimeric capping protein from *Arabidopsis* is regulated by phosphatidic acid. *Mol Biol Cell* 17:1946–1958
- Hurst AC, Meckel T, Tayefeh S, Thiel G, Homann U (2004) Trafficking of the plant potassium inward rectifier KAT1 in guard cell protoplasts of *Vicia faba*. *Plant J* 37:391–397
- Hwang JU, Lee Y (2001) Abscisic acid-induced actin reorganization in guard cells of dayflower is mediated by cytosolic

- calcium levels and by protein kinase and protein phosphatase activities. *Plant Physiol* 125:2120–2128
- Hwang JU, Suh S, Yi H, Kim J, Lee Y (1997) Actin filaments modulate both stomatal opening and inward K<sup>+</sup>-channel activities in guard cells of *Vicia faba* L. *Plant Physiol* 115:335–342
- Hwang JU, Gu Y, Lee YJ, Yang Z (2005) Oscillatory ROP GTPase activation leads the oscillatory polarized growth of pollen tubes. *Mol Biol Cell* 16:5385–5399
- Ikeda S, Yamaoka-Tojo M, Hilenski L, Patrushev NA, Anwar GM, Quinn MT, Ushio-Fukai M (2005) IQGAP1 regulates reactive oxygen species-dependent endothelial cell migration through interacting with Nox2. *Arteriosclerosis, Thrombosis, Vascular Biol* 25:2295–2300
- Iriti M, Rabotti G, De Ascensao A, Faoro F (2003) Benzothiadiazole-induced resistance modulates ozone tolerance. *J Agric Food Chem* 51:4308–4314
- Jacob T, Ritchie S, Assmann SM, Gilroy S (1999) abscisic acid signal transduction in guard cells is mediated by phospholipase D activity. *Proc Natl Acad Sci USA* 96:12192–12197
- Joo JH, Wang S, Chen JG, Jones AM, Fedoroff NV (2005) Different signaling and cell death roles of heterotrimeric G protein alpha and beta subunits in the *Arabidopsis* oxidative stress response to ozone. *Plant Cell* 17:957–970
- Jung JY, Kim YW, Kwak JM, Hwang JU, Young J, Schroeder JI, Hwang I, Lee Y (2002) Phosphatidylinositol 3- and 4-phosphate are required for normal stomatal movements. *Plant Cell* 14:2399–2412
- Kilian J, Whitehead D, Horak J, Wanke D, Weinl S, Batistic O, D'Angelo C, Bornberg-Bauer E, Kudla J, Harter K (2007) The AtGenExpress global stress expression data set: protocols, evaluation and model data analysis of UV-B light, drought and cold stress responses. *Plant J* 50:347–363
- Kim M, Hepler PK, Eun SO, Ha KS, Lee Y (1995) Actin filaments in mature guard cells are radially distributed and involved in stomatal movement. *Plant Physiol* 109:1077–1084
- Kinoshita T, Shimazaki K (1999) Blue light activates the plasma membrane H<sup>+</sup>-ATPase by phosphorylation of the C-terminus in stomatal guard cells. *EMBO J* 18:5548–5558
- Kinoshita T, Doi M, Suetsugu N, Kagawa T, Wada M, Shimazaki K (2001) Phot1 and phot2 mediate blue light regulation of stomatal opening. *Nature* 414:656–660
- Knight H, Knight MR (2000) Imaging spatial and cellular characteristics of low temperature calcium signature after cold acclimation in *Arabidopsis*. *J Exp Bot* 51:1679–1686
- Knight H, Knight MR (2001) Abiotic stress signalling pathways: specificity and cross-talk. *Trends Plant Sci* 6:262–267
- Knight H, Trewavas AJ, Knight MR (1996) Cold calcium signaling in *Arabidopsis* involves two cellular pools and a change in calcium signature after acclimation. *Plant Cell* 8:489–503
- Knight H, Trewavas AJ, Knight MR (1997) Calcium signaling in *Arabidopsis thaliana* responding to drought and salinity. *Plant J* 12:1067–1078
- Komis G, Quader H, Galatis B, Apostolakis P (2006) Macrotubule-dependent protoplast volume regulation in plasmolysed root-tip cells of *Triticum turgidum*: involvement of phospholipase D. *New Phytol* 171:737–750
- Kubitschek U, Homann U, Thiel G (2000) Osmotically evoked shrinking of guard-cell protoplasts causes vesicular retrieval of plasma membrane into the cytoplasm. *Planta* 210: 423–431
- Kwak JM, Mori IC, Pei ZM, Leonhardt N, Torres MA, Dangel JL, Bloom RE, Bodde S, Jones JD, Schroeder JI (2003) NADPH oxidase AtrbohD and AtrbohF genes function in ROS-dependent ABA signaling in *Arabidopsis*. *EMBO J* 22:2623–2633
- Kwon Y, Hofmann T, Montell C (2007) Integration of phosphoinositide- and calmodulin-mediated regulation of TRPC6. *Mol Cell* 25:491–503
- Lahav M, Abu-Abied M, Belausov E, Schwartz A, Sadot E (2004) Microtubules of guard cells are light sensitive. *Plant Cell Physiol* 45:573–582
- Lam E, Kato N, Lawton M (2001) Programmed cell death, mitochondria and the plant hypersensitive response. *Nature* 411:848–853
- Lamb D, Dixon RA (1997) The oxidative burst in plant disease resistance. *Annu Rev Plant Physiol Plant Mol Biol* 48:251–275
- Lange K, Brandt U (1996) Calcium storage and release properties of F-actin: evidence for the involvement of F-actin in cellular calcium signaling. *FEBS Lett* 395:137–142
- Lange K, Gartzke J (2006) A critical comparison of the current view of Ca signaling with the novel concept of F-actin-based Ca<sup>2+</sup> signaling. *Critical Rev Euk Gene Expr* 16:307–365
- Laxalt AM, Munnik T (2002) Phospholipid signalling in plant defence. *Curr Opin Plant Biol* 5:332–338
- Leckie CP, McAinsh MR, Allen GJ, Sanders D, Hetherington AM (1998) Abscisic acid-induced stomatal closure mediated by cyclic ADP-ribose. *Proc Natl Acad Sci USA* 95:15837–15842
- Lecourieux D, Mazars C, Pauly N, Ranjeva R, Pugin A (2002) Analysis and effects of cytosolic free calcium increases in response to elicitors in *Nicotiana plumbaginifolia* cells. *Plant Cell* 14:2627–2641
- Lecourieux D, Ranjeva R, Pugin A (2006) Calcium in plant defence-signalling pathways. *New Phytol* 171:249–269
- Lee KH, Piao HL, Kim HY, Choi SM, Jiang F, Hartung W, Hwang I, Kwak JM, Lee JJ, Hwang I (2006) Activation of glucosidase via stress-induced polymerization rapidly increases active pools of abscisic acid. *Cell* 126:1109–1120
- Lee YR, Liu B (2004) Cytoskeletal motors in *Arabidopsis*. Sixty-one kinesins and seventeen myosins. *Plant Physiol* 136:3877–3883
- Lemichez E, Wu Y, Sanchez JP, Mettouchi A, Mathur J, Chua NH (2001) Inactivation of AtRac1 by abscisic acid is essential for stomatal closure. *Genes Dev* 15:1808–1816

- Leonhardt N, Kwak JM, Robert N, Waner D, Leonhardt G, Schroeder JI (2004) Microarray expression analyses of *Arabidopsis* guard cells and isolation of a recessive abscisic acid hypersensitive protein phosphatase 2C mutant. *Plant Cell* 16:596–615
- Levchenko V, Konrad KR, Dietrich P, Roelfsema MR, Hedrich R (2005) Cytosolic abscisic acid activates guard cell anion channels without preceding  $\text{Ca}^{2+}$  signals. *Proc Natl Acad Sci USA* 102:4203–4208
- Levine A, Tenhaken R, Dixon R, Lamb C (1994)  $\text{H}_2\text{O}_2$  from the oxidative burst orchestrates the plant hypersensitive disease resistance response. *Cell* 79:583–593
- Leyman B, Geelen D, Quintero FJ, Blatt MR (1999) A tobacco syntaxin with a role in hormonal control of guard cell ion channels. *Science* 283:537–540
- Lipka V, Panstruga R (2005) Dynamic cellular responses in plant-microbe interactions. *Curr Opin Plant Biol* 8:625–631
- Lillemeier BF, Pfeiffer JR, Surviladze Z, Wilson BS, Davis MM (2006) Plasma membrane-associated proteins are clustered into islands attached to the cytoskeleton. *Proc Natl Acad Sci U S A* 103:18992–18997
- Liu X, Yue Y, Li B, Nie Y, Li W, Wu WH, Ma L (2007) A G protein-coupled receptor is a plasma membrane receptor for the plant hormone abscisic acid. *Science* 315:1712–1716
- Logemann E, Hahlbrock K (2002) Crosstalk among stress responses in plants: pathogen defense overrides UV protection through an inversely regulated ACE/ACE type of light-responsive gene promoter unit. *Proc Natl Acad Sci USA* 99:2428–2432
- MacRobbie EA (1993)  $\text{Ca}^{2+}$  and cell signalling in guard cells. *Semin Cell Biol* 4:113–122
- MacRobbie EA (1998) Signal transduction and ion channels in guard cells. *Philos Trans R Soc Lond B Biol Sci* 353:1475–1488
- Mahalingam R, Fedoroff N (2003) Stress response, cell death and signalling: the many faces of reactive oxygen species. *Physiol Plant* 119:56–68
- Mahalingam R, Shah N, Scrymgeour A, Fedoroff N (2005) Temporal evolution of the *Arabidopsis* oxidative stress response. *Plant Mol Biol* 57:709–730
- Malacombe M, Bader MF, Gasman S (2006) Exocytosis in neuro-endocrine cells: new tasks for actin. *Biochem Biophys Acta* 1763:1175–1183
- Marcus AI, Moore RC, Cyr RJ (2001) The role of microtubules in guard cell function. *Plant Physiol* 125:387–395
- Marten H, Konrad KR, Dietrich P, Roelfsema MR, Hedrich R (2007)  $\text{Ca}^{2+}$ -dependent and independent abscisic acid activation of plasma membrane anion channels in guard cells of *Nicotiana tabacum*. *Plant Physiol* 143:28–37
- McAinsh MR, Hetherington AM (1998) Encoding specificity in  $\text{Ca}^{2+}$  signaling systems. *Trends Plant Sci* 3:32–36
- McAinsh MR, Brownlee C, Hetherington AM (1992) Visualizing changes in cytosolic-free  $\text{Ca}^{2+}$  during the response of stomatal guard cells to abscisic acid. *Plant Cell* 4:1113–1122
- McAinsh MR, Webb A, Taylor JE, Hetherington AM (1995) Stimulus-induced oscillations in guard cell cytosolic free calcium. *Plant Cell* 7:1207–1219
- McCurdy DW, Kovar DR, Staiger CJ (2001) Actin and actin-binding proteins in higher plants. *Protoplasma* 215:89–104
- Meckel T, Hurst AC, Thiel G, Homann U (2004) Endocytosis against high turgor: intact guard cells of *Vicia faba* constitutively endocytose fluorescently labelled plasma membrane and GFP-tagged K-channel KAT1. *Plant J* 39:182–193
- Meckel T, Hurst AC, Thiel G, Homann U (2005) Guard cells undergo constitutive and pressure-driven membrane turnover. *Protoplasma* 226:23–29
- Meckel T, Gall L, Semrau S, Homann U, Thiel G (2007) Guard cells elongate: relationship of volume and surface area during stomatal movement. *Biophys J* 92:1072–1080
- Meinhard M, Grill E (2001) Hydrogen peroxide is a regulator of ABI1, a protein phosphatase 2C from *Arabidopsis*. *FEBS Lett* 508:443–446
- Meinhard M, Rodriguez PL, Grill E (2002) The sensitivity of ABI2 to hydrogen peroxide links the abscisic acid-response regulator to redox signalling. *Planta* 214:775–782
- Meskiene I, Baudouin E, Schweighofer A, Liwosz A, Jonak C, Rodriguez PL, Jelinek H, Hirt H (2003) Stress-induced protein phosphatase 2C is a negative regulator of a mitogen activated protein kinase. *J Biol Chem* 278:18945–18952
- Mishra G, Zhang W, Deng F, Zhao J, Wang X (2006a) A bifurcating pathway directs abscisic acid effects on stomatal closure and opening in *Arabidopsis*. *Science* 312(5771):264–266
- Mishra NS, Tuteja R, Tuteja N (2006b) Signaling through MAP Kinase networks in plants. *Arch Biochem Biophys* 452:55–68
- Mori IC, Schroeder JI (2004) Reactive oxygen species activation of plant  $\text{Ca}^{2+}$  channels. A signaling mechanism in polar growth, hormone transduction, stresses signaling and hypothetically mechano-transduction. *Plant Physiol* 135:702–708
- Morris CE, Homann U (2001) Cell surface area regulation and membrane tension. *J Membrane Biol* 179:79–102
- Mou Z, Fan W, Dong X (2003) Inducers of plant systemic acquired resistance regulate NPR1 function through redox changes. *Cell* 113:935–944
- Mullineaux P, Ball L, Escobar C, Karpinska B, Creissen G, Karpinski S (2000) Are diverse signalling pathways integrated in the regulation of *Arabidopsis* antioxidant defense gene expression in response to excess excitation energy? *Philos Trans R Soc Lond B Biol Sci* 355:1531–1540
- Munnik T (2001) Phosphatidic acid: an emerging plant lipid second messenger. *Trends Plant Sci* 6:227–233
- Nebel T, Oh SW, Luna EJ (2000) Membrane cytoskeleton: PIP(2) pulls the strings. *Curr Biol* 10:R351–R354
- Nibau C, Wu HM, Cheung AY (2006) RAC/ROP GTPases: ‘hubs’ for signal integration and diversification in plants. *Trends Plant Sci* 11:309–315



- Orozco-Cardenas M, Narvaez-Vasquez J, Ryan C (2001) Hydrogen peroxide acts as a second messenger for the induction of defense genes in tomato plants in response to wounding, systemin, and methyl jasmonate. *Plant Cell* 13:179–191
- Osakabe Y, Maruyama K, Seki M, Satou M, Shinozaki K, Yamaguchi-Shinozaki K (2005) Leucine-rich repeat receptor-like kinase1 is a key membrane-bound regulator of abscisic acid early signaling in *Arabidopsis*. *Plant Cell* 17:1105–1119
- Paget MS, Buttner MJ (2003) Thiol-based regulatory switches. *Annu Rev Genetics* 37:91–121
- Pandey S, Assmann SM (2004) The *Arabidopsis* putative G protein-coupled receptor GCR1 interacts with the G protein  $\alpha$  subunit GPA1 and regulates abscisic acid signaling. *Plant Cell* 16:1616–1632
- Park KY, Jung JY, Park J, Hwang JU, Kim YW, Hwang I, Lee Y (2003) A role for phosphatidylinositol 3-phosphate in abscisic acid-induced reactive oxygen species generation in guard cells. *Plant Physiol* 132:92–98
- Pei ZM, Murata Y, Benning G, Thomine S, Klusener B, Allen GJ, Grill E, Schroeder JI (2000) Calcium channels activated by hydrogen peroxide mediate abscisic acid signalling in guard cells. *Nature* 406:731–734
- Penner R, Fleig A (2004) Store-operated calcium entry: a tough nut to CRAC. *Sci STKE* 2004: pe38
- Persson C, Sjoblom T, Groen A, Kappert K, Engstrom U, Hellman U, Heldin CH, den Hertog J, Ostman A (2004) Preferential oxidation of the second phosphatase domain of receptor-like PTP-alpha revealed by an antibody against oxidized protein tyrosine phosphatases. *Proc Natl Acad Sci USA* 101:1886–1891
- Plieth C (2005) Calcium: just another regulator in the machinery of life? *Ann Bot (Lond)* 96:1–8
- Price AH, Taylor A, Ripley SJ, Griffiths A, Trewavas AJ, Knight MR (1994) Oxidative signals in tobacco increase cytosolic calcium. *Plant Cell* 6:1301–1310
- Putney JW (2007) Inositol lipids and TRPC channel activation. *Biochemical Society symposium*: 37–45
- Razem FA, El-Kereamy A, Abrams SR, Hill RD (2006) The RNA-binding protein FCA is an abscisic acid receptor. *Nature* 439:290–294
- Rochon A, Boyle P, Wignes T, Fobert PR, Despres C (2006) The coactivator function of *Arabidopsis* NPR1 requires the core of its BTB/POZ domain and the oxidation of C-terminal cysteines. *Plant Cell* 18:3670–3685
- Roelfsema MR, Hedrich R (2005) In the light of stomatal opening: new insights into the Watergate. *New Phytol* 167:665–691
- Sakamoto K, Briggs WR (2002) Cellular and subcellular localization of phototropin 1. *Plant Cell* 14:1723–1735
- Samaj J, Baluska F, Hirt H (2004) From signal to cell polarity: mitogen activated protein kinases as sensors and effectors of cytoskeleton dynamicity. *J Exp Bot* 55:189–198
- Sandermann H Jr (2000) Active oxygen species as mediators of plant immunity: three case studies. *Biol Chem* 381:649–653
- Sanders D, Brownlee C, Harper JF (1999) Communicating with calcium. *Plant Cell* 11:691–706
- Schmelzer E (2002) Cell polarization, a crucial process in fungal defence. *Trends Plant Sci* 7:411–415
- Schroeder JI, Allen GJ, Hugouvieux V, Kwak JM, Waner D (2001) Guard cell signal transduction. *Annu Rev Plant Physiol Plant Mol Biol* 52:627–658
- Schwartz A, Wu WH, Tucker EB, Assmann SM (1994) Inhibition of inward  $K^+$  channels and stomatal response by abscisic acid: an intracellular locus of phytohormone action. *Proc Natl Acad Sci USA* 91:4019–4023
- Scraser-Field SA, Knight MR (2003) Calcium: just a chemical switch? *Curr Opin Plant Biol* 6:500–506
- Seki M, Satou M, Sakurai T, Akiyama K, Iida K, Ishida J, Nakajima M, Enju A, Narusaka M, Fujita M, Oono Y, Kamei A, Yamaguchi-Shinozaki K, Shinozaki K (2004) RIKEN *Arabidopsis* full-length (RAFL) cDNA and its applications for expression profiling under abiotic stress conditions. *J Exp Botany* 55:213–223
- Shen YY, Wang XF, Wu FQ, Du SY, Cao Z, Shang Y, Wang XL, Peng CC, Yu XC, Zhu SY, Fan RC, Xu YH, Zhang DP (2006) The Mg-chelatase H subunit is an abscisic acid receptor. *Nature* 443:823–826
- Shoji T, Suzuki K, Abe T, Kaneko Y, Shi H, Zhu JK, Rus A, Hasegawa PM, Hashimoto T (2006) Salt stress affects cortical microtubule organization and helical growth in *Arabidopsis*. *Plant Cell Physiol* 47:1158–1168
- Shope JC, Mott KA (2006) Membrane trafficking and osmotically induced volume changes in guard cells. *J Exp Bot* 57:4123–4131
- Shope JC, DeWald DB, Mott KA (2003) Changes in surface area of intact guard cells are correlated with membrane internalization. *Plant Physiol* 133:1314–1321
- Sieburth LE, Deyholos MK (2006) Vascular development: the long and winding road. *Curr Opin Plant Biol* 9:48–54
- Sitia R, Molteni SN (2004) Stress, protein (mis) folding, and signaling: the redox connection. *Sci STKE* 2004: pe27
- Skare P, Karlsson R (2002) Evidence for two interaction regions for phosphatidylinositol(4, 5)-bisphosphate on mammalian profilin I. *FEBS Lett* 522:119–124
- Smith LG, Oppenheimer DG (2005) Spatial control of cell expansion by the plant cytoskeleton. *Annu Rev Cell Devel Biol* 21:271–295
- Somerville C (2006) Cellulose synthesis in higher plants. *Annu Rev Cell Devel Biol* 22:53–78
- Staiger CJ (2000) Signaling to the actin cytoskeleton in plants. *Annu Rev Plant Physiol Plant Mol Biol* 51:257–288
- Staxen II, Pical C, Montgomery LT, Gray JE, Hetherington AM, McAinsh MR (1999) abscisic acid induces oscillations in guard-cell cytosolic free calcium that involve phosphoinositide-specific phospholipase C. *Proc Natl Acad Sci USA* 96:1779–1784
- Sutter JU, Campanoni P, Blatt MR, Paneque M (2006a) Setting SNAREs in a different wood. *Traffic* 7:627–638
- Sutter JU, Campanoni P, Tyrrell M, Blatt MR (2006b) Selective mobility and sensitivity to SNAREs is exhibited by the *Arabidopsis* KAT1  $K^+$  channel at the plasma membrane. *Plant Cell* 18:935–954

- Takahashi K, Isobe M, Knight MR, Trewavas AJ, Muto S (1997) Hypoosmotic shock induces increases in cytosolic  $\text{Ca}^{2+}$  in tobacco suspension-culture cells. *Plant Physiol* 113:587–594
- Takemiya A, Kinoshita T, Asanuma M, Shimazaki K (2006) Protein phosphatase 1 positively regulates stomatal opening in response to blue light in *Vicia faba*. *Proc Natl Acad Sci USA* 103:13549–13554
- Takemoto D, Hardham AR (2004) The cytoskeleton as a regulator and target of biotic interactions in plants. *Plant Physiol* 136:3864–3876
- Tall EG, Spector I, Pentylala SN, Bitter I, Rebecchi MJ (2000) Dynamics of phosphatidylinositol 4, 5-bisphosphate in actin-rich structures. *Curr Biol* 10:743–746
- Testerink C, Dekker HL, Lim ZY, Johns MK, Holmes AB, Koster CG, Ktistakis N, Munnik T (2004) Isolation and identification of phosphatidic acid targets from plants. *Plant J* 39:527–536
- Toker A (1998) The synthesis and cellular roles of phosphatidylinositol 4, 5-bisphosphate. *Curr Opin Cell Biol* 10:254–261
- Torres MA, Dangel JL (2005) Functions of the respiratory burst oxidase in biotic interactions, abiotic stress and development. *Curr Opin Plant Biol* 8:397–403
- Tosti N, Pasqualini S, Borgogni A, Ederli L, Falistocco E, Crispi S, Paolucci F (2006) Gene expression profiles of  $\text{O}_3$ -treated *Arabidopsis* plants. *Plant Cell Environ* 29:1686–1702
- Trewavas A, Gilroy S (1991) Signal transduction in plant cells. *Trends Genet* 7:356–361
- Trewavas A, Knight M (1994) Mechanical signalling, calcium and plant form. *Plant Mol Biol* 265:1329–1341
- Ulm R, Revenkova E, di Sansebastiano GP, Bechtold N, Paszkowski J (2001) Mitogen activated protein kinase phosphatase is required for genotoxic stress relief in *Arabidopsis*. *Genes Dev* 15:699–709
- Ulm R, Ichimura K, Mizoguchi T, Peck SC, Zhu T, Wang X, Shinozaki K, Paszkowski J (2002) Distinct regulation of salinity and genotoxic stress responses by *Arabidopsis* MAP kinase phosphatase 1. *EMBO J* 21:6483–6493
- van Hulten M, Pelser M, van Loon LC, Pieterse CM, Ton J (2006) Costs and benefits of priming for defense in *Arabidopsis*. *Proc Natl Acad Sci USA* 103:5602–5607
- Vavasseur A, Raghavendra AS (2005) Guard cell metabolism and  $\text{CO}_2$  sensing. *New Phytol* 165:665–682
- Vermeer JE, van Leeuwen W, Tobena-Santamaria R, Laxalt AM, Jones DR, Divecha N, Gadella TW Jr, Munnik T (2006) Visualization of PtdIns3P dynamics in living plant cells. *Plant J* 47:687–700
- Volkman D, Mori T, Tirilapur UK, Konig K, Fujiwara T, Kendrick-Jones J, Baluska F (2003) Unconventional myosins of the plant-specific class VIII: endocytosis, cytokinesis, plasmodesmata/pit-fields and cell-to-cell coupling. *Cell Biol Int* 27:289–291
- Wang D, Weaver ND, Kesarwani M, Dong X (2005) Induction of protein secretory pathway is required for systemic acquired resistance. *Science* 308:1036–1040
- Wang J, Tekle E, Oubrahim H, Mieyal JJ, Stadtman ER, Chock PB (2003) Stable and controllable RNA interference: Investigating the physiological function of glutathionylated actin. *Proc Natl Acad Sci USA* 100:5103–5106
- Wang X (2005) Regulatory functions of phospholipase D and phosphatidic acid in plant growth, development, and stress responses. *Plant Physiol* 139:566–573
- Wang X (2006) Phospholipid-derived signaling in plant response to temperature and water stresses. *Genet Eng* 27:57–66
- Wang XQ, Ullah H, Jones AM, Assmann SM (2001a) G protein regulation of ion channels and abscisic acid signaling in *Arabidopsis* guard cells. *Science* 292:2070–2072
- Wang ZY, Seto H, Fujioka S, Yoshida S, Chory J (2001b) BRI1 is a critical component of a plasma-membrane receptor for plant steroids. *Nature* 410:380–383
- Wick P, Gansel X, Oulevey C, Page V, Studer I, Durst M, Sticher L (2003) The expression of the t-SNARE AtSNAP33 is induced by pathogens and mechanical stimulation. *Plant Physiol* 132:343–351
- Wiermer M, Feys BJ, Parker JE (2005) Plant immunity: the EDS1 regulatory node. *Curr Opin Plant Biol* 8:383–389
- Willemsen V, Scheres B (2004) Mechanisms of pattern formation in plant embryogenesis. *Annu Rev Genetics* 38:587–614
- Williams ME, Torabinejad J, Cohick E, Parker K, Drake EJ, Thompson JE, Horter M, Dewald DB (2005) Mutations in the *Arabidopsis* phosphoinositide phosphatase gene SAC9 lead to overaccumulation of PtdIns(4, 5)P<sub>2</sub> and constitutive expression of the stress-response pathway. *Plant Physiol* 138:686–700
- Wood NT, Allan AC, Haley A, Viry-Moussaid M, Trewavas AJ (2000) The characterization of differential calcium signalling in tobacco guard cells. *Plant J* 24:335–344
- Wood NT, Haley A, Viry-Moussaid M, Johnson CH, van Der Luit AH, Trewavas AJ (2001) The calcium rhythms of different cell types oscillate with different circadian phases. *Plant Physiol* 125:787–796
- Wu Y, Kuzma J, Marechal E, Graeff R, Lee HC, Foster R, Chua NH (1997) Abscisic acid signaling through cyclic ADP-ribose in plants. *Science* 278:2126–2130
- Xiao Y, Chen Y, Huang R, Chen J, Wang XC (2004) Depolymerization of actin cytoskeleton is involved in stomatal closure-induced by extracellular calmodulin in *Arabidopsis*. *Sci China Life Sci* 47:454–460
- Xiong TC, Bourque S, Lecourieux D, Amelot N, Grat S, Briere C, Mazars C, Pugin A, Ranjeva R (2006) Calcium signaling in plant cell organelles delimited by a double membrane. *Biochim Biophys Acta* 1763:1209–1215
- Xu D, Rovira II, Finkel T (2002) Oxidants painting the cysteine chapel: redox regulation of PTPs. *Dev Cell* 2:251–252
- Xu J, Hofhuis H, Heidstra R, Sauer M, Friml J, Scheres B (2006) A molecular framework for plant regeneration. *Science* 311:385–388
- Yuan HY, Yao LL, Jia ZQ, Li Y, Li YZ (2006) *Verticillium dahliae* toxin induced alterations of cytoskeletons and nucleoli in *Arabidopsis thaliana* suspension cells. *Protoplasma* 229:75–82

- Zalejski C, Zhang Z, Quettier AL, Maldiney R, Bonnet M, Brault M, Demandre C, Miginiac E, Rona JP, Sotta B, Jeannette E (2005) Diacylglycerol pyrophosphate is a second messenger of abscisic acid signaling in *Arabidopsis thaliana* suspension cells. *Plant J* 42:145–152
- Zhang X, Zhang L, Dong F, Gao J, Galbraith DW, Song CP (2001) Hydrogen peroxide is involved in abscisic acid-induced stomatal closure in *Vicia faba*. *Plant Physiol* 126:1438–1448
- Zhu J, Fu X, Koo YD, Zhu JK, Jenney FE Jr, Adams MW, Zhu Y, Shi H, Yun DJ, Hasegawa PM, Bressan RA (2007) An enhancer mutant of *Arabidopsis* salt overly sensitive 3 mediates both ion homeostasis and the oxidative stress response. *Mol Cell Biol* 14:5214–5224

## Global Climate Change, Stress and Plant Productivity

Altaf Ahmad, Hema Diwan, and Yash P. Abrol\*  
*Molecular Ecology Laboratory, Department of Botany, Faculty of Science,  
Jamia Hamdard, New Delhi, 110062, India*

Summary .....	503
I Introduction .....	504
II Elevated Carbon Dioxide .....	504
A Photosynthesis.....	505
B Respiration.....	505
C Transpiration .....	506
D Nitrogen Assimilation .....	506
E Water Use Efficiency.....	507
F Crop Productivity.....	508
III High Temperature.....	509
A Oxidative Stress.....	510
B Photosynthesis.....	510
C Crop Phenology.....	511
D Crop Productivity .....	513
IV Ultraviolet Radiation .....	514
V Tropospheric Ozone.....	515
VI Biotic Stress.....	515
VII Conclusions and Future Prospects.....	516
Acknowledgements .....	517
References .....	517

### Summary

Global climate change, rated as the most serious threat to the environment, has been the center of debate among environmentalists and policy makers as it has become not only an environmental, a political and an economic issue, but also a global problem, of which agriculture is the major target. At the plant or field scale, climate change is likely to interact with rising CO<sub>2</sub> concentrations and other environmental changes such as temperature, precipitation (associated with changes in tropo-, as well as stratospheric ozone levels) and UV-B radiation to affect crop physiology. The present chapter reviews the potential changes in plant physiological processes caused by these factors.

**Keywords:** Carbon dioxide • crops • global warming • green house gases • photosynthesis • productivity • temperature

---

\*Author for correspondence, e-mail: ypabrol@vsnl.com



## I Introduction

Agriculture is an essential component of society's well-being. It occupies 40% of the land surface, consumes 70% of global water resources and manages biodiversity at genetic, species and ecosystem levels. High-yielding crop varieties, intensive use of inorganic fertilizers and pesticides, expansion of irrigation facilities and capital-intensive farm management have resulted in an unprecedented increase in global agricultural productivity, since 1950s. Further, agricultural research has expanded its scope to include sustainable and resource-efficient crop systems and farm management practices. But providing sufficient food for the world's population is becoming more difficult now, as our population size is increasing and land, water, as well as vegetative resources, are being progressively degraded through prolonged overuse.

There is also a concern that these problems will be exacerbated in the future by global climate change. An overwhelming body of scientific evidence paints a clear picture that this climate change is happening at a global level. It is largely caused by the unprecedented increase in greenhouse gas (GHG) emissions from anthropogenic sources (Fig. 1). Between 1970 and 2004, global emissions of CO<sub>2</sub>, CH<sub>4</sub>, N<sub>2</sub>O, weighed by their global warming potential (GWP), have increased differentially by 70% (24% between 1990 and 2004), from 28.7 to 49 Gigatonnes of carbon dioxide equivalents (GtCO<sub>2</sub>-eq) (IPCC 2007). CO<sub>2</sub> emissions have grown by about 80% between 1970 and 2004 (28% between 1990 and 2004) and represented 77% of total anthropogenic GHG emissions in 2004. As a result, an enhanced greenhouse effect is being observed

that is trapping more of the sun's heat near the earth's surface and gradually pushing the planet's climate system into uncharted territory. The overall predictability of weather and climate conditions would decrease, making day-to-day and medium-term planning of farm operations more difficult. There will be loss of biodiversity from some of the most fragile environments, such as tropical forests and mangroves. Predicted sea-level rise (40 cm in the coming 100 years) would submerge valuable coastal agricultural land. The incidence of diseases and pests, especially alien ones, could increase. The present agro-ecological zones could shift, over hundreds of kilometers horizontally and hundreds of meters altitudinally, with the hazard that some plants, especially trees, and animal species cannot follow in time, as a consequence, farming systems cannot adjust themselves. Inversely, higher temperatures would allow seasonally longer plant growth and will force us to grow crops in cool and mountainous areas, allowing in some cases increased cropping and production. In contrast, in already warm areas climate change can cause reduced productivity (Sombroek and Gommers 1998). These effects are affecting our ability to expand food production which is required to feed a population of over 10,000 million people, projected for the middle of the next century. Increased levels of CO<sub>2</sub>, tropospheric ozone (O<sub>3</sub>), UV-B (through depleted stratospheric ozone); increased temperatures and the associated intensification of the hydrological cycle directly affect the plant physiological processes, leading to reduced agricultural productivity. This chapter attempts to assess some of the potential changes in plant physiological processes by the factors responsible for this climate change.

---

*Abbreviations:* EGP—eastern gangetic plains FAO—Food and Agricultural Organization of the United Nations FACE—free-air CO<sub>2</sub> enrichment GCM—general circulation models GFDL—Geophysical Fluid Dynamics Laboratory GWP—global warming potential GISS—Goddard Institute for Space Studies GHGs—greenhouse gases HSPs—heat shock proteins IPCC—Intergovernmental Panel on Climate Change NUE—nitrogen use efficiency PFCs—perfluorocarbons RWC—relative water content RuBisCo—ribulose-1,5-biphosphate carboxylase/oxygenase SREC—Special Report on Emission Scenarios TKW—thermal kinetic window UKMO—United Kingdom Meteorological Office WUE—water use efficiency

## II Elevated Carbon Dioxide

Plants have been directly affected by rising atmospheric CO<sub>2</sub> concentration because they are the first molecular link between the atmosphere and the biosphere. Scaling carbon dioxide levels have the ability to affect all ecosystems, from microscopic cellular organisms to the macroscopic agro-ecosystems. CO<sub>2</sub> has the potential to affect major physiological processes namely photosynthesis, respiration and transpiration.

Fig. 1. Green house gases and their anthropogenic sources (Adapted from Uprety et al. 2007).

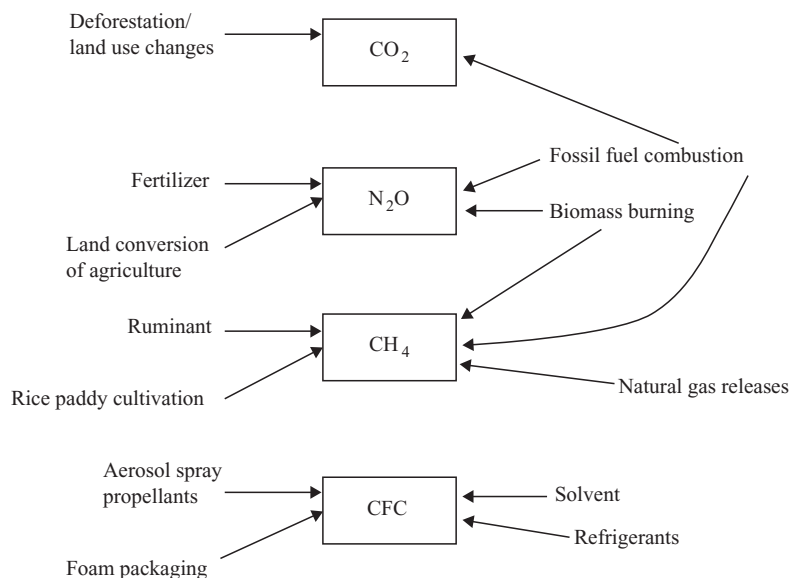

### A Photosynthesis

CO<sub>2</sub> is an essential component of the process of photosynthesis, upon which life on earth ultimately depends (Whitmarsh and Govindjee 1999; Leegood et al. 2000). It serves as a substrate during photosynthetic carbon assimilation. Plant species vary in their response to CO<sub>2</sub>, in part because of differing photosynthetic mechanisms. C<sub>3</sub> plants (e.g., wheat, rice, oilseed, pulses) respond to elevated CO<sub>2</sub>, since it reduces the oxygenase activity of ribulose 1,5-bisphosphate carboxylase/oxygenase (RuBisCo) enzymes in plants. C<sub>4</sub> plants (e.g., sorghum, maize, sugarcane) show little or no photosynthetic response to elevated CO<sub>2</sub>, because C<sub>4</sub> pathway is not competitively inhibited by O<sub>2</sub> and is completely saturated by CO<sub>2</sub>. The differing responses of C<sub>3</sub> and C<sub>4</sub> species to various levels of CO<sub>2</sub> are likely to change their competitiveness. C<sub>3</sub> weeds are likely to become a problem in C<sub>4</sub> crops, while C<sub>3</sub> crops may get an advantage over C<sub>4</sub> weeds. This could affect the whole complexion of agro-ecosystems (Abrol et al. 1991; Uprety et al. 2007). Natural vegetation is also expected to show a significant response to rising CO<sub>2</sub>, since 95% of the higher plant species and 100% of the trees are C<sub>3</sub> plants (Drake 1992). Plants having C<sub>4</sub> photosynthetic pathway have negligible photosynthetic response to elevated CO<sub>2</sub>, because the C<sub>4</sub> cycle increases the CO<sub>2</sub> concentration inside bundle sheath cells to a point

where very little photorespiration occurs and the Calvin-Benson-Bassham cycle is nearly saturated with CO<sub>2</sub> (Conroy 1992; Ziska et al. 1999). However, there is no consensus on the quantitative effects of increased CO<sub>2</sub> on plant physiology and growth, due to differential response at different stages of growth of different crop species and growth limiting environmental factors (Uprety et al. 2007).

Accumulation of non-structural carbohydrates in leaves and other plant organs in the form of starch, soluble carbohydrates or poly-fructosans takes place, depending on the species. In some cases, there may be a feedback inhibition of photosynthesis, associated with accumulation of non-structural carbohydrates. Increased carbohydrate accumulation, especially in leaves, may suggest that crop plants grown under CO<sub>2</sub> enrichment are not fully adapted to take advantage of elevated CO<sub>2</sub>. This may be because the CO<sub>2</sub>-enriched plants do not have an adequate sink (inadequate growth capacity), or lack the capacity to load phloem and translocate soluble carbohydrates. Improvement of photo-assimilate utilization should be one goal while designing cultivars for the future (Hall and Allen 1993).

### B Respiration

Respiration rate per unit of the land area is expected to be higher with the increase in photosynthesis,

growth rate and substrate level, because higher biomass requires higher energy supply for maintenance and growth. There may be a reduction in specific respiration rates by both the short-term exposure to elevated CO<sub>2</sub> and the long-term growth at elevated CO<sub>2</sub> (Amthor 1997). The dark respiration rate of rice expressed on a land area basis increased with increasing CO<sub>2</sub>, which can be attributed to an increase in biomass, while specific respiration rate per unit biomass decreased (Baker et al. 1992a). Since, elevated CO<sub>2</sub> can reduce plant tissue nitrogen concentration (Baker et al. 1992b; Ziska et al. 1996; Upreti et al. 2000, 2003), both the growth and maintenance components of respiration can be affected by tissue-N concentration (Amthor 1994).

### C Transpiration

Elevated CO<sub>2</sub> is expected to decrease stomatal conductance in most species, resulting in less transpiration per unit leaf area. Forty percent reduction in stomatal conductance induced by doubling of CO<sub>2</sub> has generally resulted in only a 10% (or less) reduction in crop canopy water, used in chamber or field experimental conditions. However, leaf area index of some crops can also be affected and may increase. Actual changes in crop evapo-transpiration is governed by the crop energy balance, as mitigated by stomatal conductance, leaf area index, crop structure and any changing meteorological factors. Upreti et al. (2002) demonstrated that the stomata of lower epidermis were more sensitive to CO<sub>2</sub> enrichment than those of the upper epidermis in rice cultivars (Table 1). They have attributed the reduction in stomatal conductance to balancing of the resource use and to the maintenance of Ci:Ca ratio under elevated CO<sub>2</sub>. Such changes occur in rice cultivars through its effect on stomatal size and numbers. Gray et al. (2000) isolated the *Arabidopsis* gene *HIC* (for high carbon dioxide) that encodes a negative regulator of stomatal development in response to CO<sub>2</sub>. The mutant *HIC* plants exhibit upto 42% increase in stomatal density in response to doubling of CO<sub>2</sub> concentration. CO<sub>2</sub> responsive genes have also been identified in cyanobacteria (Kaplan et al. 2001) and the green alga *Chlamydomonas* (Eriksson et al. 1998). Certain cyanobacterial genes are transcribed only under low CO<sub>2</sub>, while in case

of others, the level of transcript increases during acclimation.

Elevated CO<sub>2</sub> also causes significant anatomical changes. However, such investigations, so far, are limited. Transmission electron microscope (TEM) studies of leaf tissues showed a significant increase in the thickness of epidermis, size of mesophyll cells, accumulation of starch, as well as the size and number of starch granules per chloroplast in *Brassica juncea*, under elevated CO<sub>2</sub> condition (Upreti et al. 2001). It appears that by increasing the number and size of palisade cells and concomitantly the number of chloroplast per leaf, more storage sites for starch were made available under stress conditions, which was otherwise lacking such sites and sink capacity for starch accumulation. The adverse effect on chloroplast structure, both due to moisture stress and starch overloading, was decreased by elevated CO<sub>2</sub>. The leaf anatomy reflected an optimization strategy due to high CO<sub>2</sub> level that allowed the loading of chloroplast with excessive oval starch grains to reduce the adverse effects of drought on these components in *B. juncea* leaves. Upreti et al. (2004) observed that elevated CO<sub>2</sub> altered the vessel characters of shoot and root of *Brassica* species. The increase in radial width of xylems (meta+proto) under elevated CO<sub>2</sub> levels indicated more transfer of water and nutrients from the soil to the plants resulting in higher water status maintained throughout the growth period, whereas, the increase in phloem size helped to transfer the excessive solute material from source to sink.

### D Nitrogen Assimilation

The carbon:nitrogen ratio of leaves of plants is usually increased under CO<sub>2</sub> enrichment. Plants may acclimate to elevated CO<sub>2</sub> by requiring less RuBisCo and photosynthetic apparatus, which would lead to lower nitrogen content. (For a background on photosynthetic nitrogen assimilation, see Foyer and Noctor 2002). The overall change in C:N ratios is governed both by increases in structural and non-structural carbohydrates, and by decreases in protein content. However, seed nitrogen content is hardly affected (Allen et al. 1988). Short term exposure to elevated CO<sub>2</sub> concentration diverted photosynthetic reductant from NO<sub>3</sub><sup>-</sup> or NO<sub>2</sub><sup>-</sup> reduction to CO<sub>2</sub> fixation, whereas with longer exposures to elevated CO<sub>2</sub>, wheat

Table 1. Effect of elevated CO<sub>2</sub> concentration (EC) on the leaf, stomatal and photosynthetic characteristics of four rice cultivars. gs – stomatal conductance, Pn – net photosynthetic rate (ns = not significant).

Parameters	(CO <sub>2</sub> )	Pusa				C.D. 5%		
		Basmati-1	P-677	P-934	P2509-6-693	Cultivar	Treatment	Interaction
g <sub>s</sub> (mmol m <sup>-2</sup> s <sup>-1</sup> )	AC	0.19	0.21	0.17	0.19	0.013	0.013	ns
	EC	0.07	0.09	0.08	0.08			
Stomatal Density (mm <sup>2</sup> )	Abaxial AC	93.6	128.7	105.3	93.6	3.75	3.75	ns
	EC	81.9	105.3	119.9	87.7			
	Adaxial AC	116.9	149.1	116.9	113.5	4.20	4.20	ns
	EC	111.1	132.4	131.6	149.1			
Stomatal Index (%)	Abaxial AC	28.6	31.9	23.9	24.4	1.20	1.20	ns
	EC	35.0	35.8	29.5	31.6			
	Adaxial AC	29.8	29.8	28.1	26.6	1.60	1.60	ns
	EC	35.0	35.0	34.6	40.1			
Stomatal size (μm)	Length AC	20.2	17.5	20.2	19.1	2.62	2.62	ns
	EC	21.1	24.0	22.6	19.3			
(Abaxial)	Width AC	10.4	8.9	9.2	8.4	ns	1.35	ns
	EC	10.9	11.7	11.1	11.5			
(Adaxial)	Length AC	19.8	17.3	18.1	18.1	1.25	1.25	ns
	EC	20.3	19.3	18.8	21.7			
Stroma (μm)	Width AC	11.3	7.0	7.5	9.6	1.10	1.10	ns
	EC	12.1	7.7	11.5	11.8			
(Abaxial)	Length AC	1.6	0.98	2.0	1.0	0.35	0.35	ns
	EC	2.1	2.2	2.2	1.7			
(Adaxial)	AC	0.88	1.4	0.92	0.7	0.018	0.018	ns
	EC	1.9	1.7	0.98	1.7			
Epidermal cell density (mm <sup>-2</sup> )	Abaxial AC	233.9	214.9	336.3	290.6	7.25	7.25	9.61
	EC	152.0	192.9	286.5	190.1			
	Adaxial AC	274.9	350.9	298.2	312.9	8.14	8.14	10.21
	EC	198.9	283.6	248.5	222.2			
Epidermal cell (μm)	Length AC	82.3	81.3	80.0	102.0	4.85	4.85	ns
	EC	106.6	144.6	95.6	104.0			
	Width AC	22.3	22.6	24.0	25.3	1.92	1.92	ns
	EC	26.3	27.3	24.0	29.3			
Leaf area (cm <sup>2</sup> plant <sup>-1</sup> )	AC	781.4	708.5	897.1	88.8	52.06	52.06	73.65
Leaf dry mass (g plant <sup>-1</sup> )	EC	980.5	775.3	960.2	104.7	3.24	3.24	4.56
Leaf area per unit mass (m <sup>2</sup> kg <sup>-1</sup> )	AC	12.2	14.3	17.4	18.0	4.86	4.96	ns
	EC	18.4	16.5	19.8	22.9			
Leaf mass per unit area (gm <sup>-2</sup> )	AC	6.4	4.9	5.2	4.5	2.1	2.1	ns
	EC	5.3	4.7	4.9	4.4			
Pn (μmol m <sup>-2</sup> s <sup>-1</sup> )	AC	18.1	13.6	15.3	21.8	4.54	4.54	6.42
	EC	26.5	16.9	19.4	28.5			

Source: Upreti et al. (2002).

leaves showed a diminished capacity for NO<sub>3</sub> photo-assimilation at any CO<sub>2</sub> concentration (Bloom et al. 2002). Moreover, high bicarbonate levels impeded NO<sub>2</sub> translocation into chloroplast isolated from wheat and pea leaves. Thus, elevated CO<sub>2</sub> inhibits NO<sub>3</sub> photo-assimilation and when wheat plants received NO<sub>3</sub>, in place of NH<sub>4</sub>, as a nitrogen source, CO<sub>2</sub> enhancement of shoot growth halved and CO<sub>2</sub> inhibition of shoot protein doubled. This study has implications

for the ability of wheat to use NO<sub>3</sub> as a nitrogen source under elevated CO<sub>2</sub>.

### E Water Use Efficiency

Water stress is one of the main environmental factors limiting plant growth and the productivity of many crops (Araus et al. 2002; Chaves 2002), and in the case of cereals, it actually jeopardizes



plant survival if water shortage occurs during the vegetative growth period (Volaire 2003). However, plants are able to adapt to water deficiency by shortening their growth cycle or they have the capacity of avoiding drought stress by augmenting root growth, thus increasing their water uptake (Molnár et al. 2004). Many studies have shown that plants under elevated CO<sub>2</sub> concentrations dry more slowly as water is withheld, consistent with their lower stomatal conductance and lower transpiration rate (Bunce 1998). Tyree and Alexander (1993) have suggested that elevated CO<sub>2</sub> might increase tolerance to drought by lowering osmotic potential and thereby maintaining high water potential ( $\Psi_w$ ). Osmotic potential declines more rapidly at elevated rather than ambient CO<sub>2</sub>, and consequently turgor pressure may be maintained, permitting growth to continue as water deficit develops (Sionit et al. 1980). Moreover, plants grown in elevated CO<sub>2</sub> conditions may utilize less water, use it more efficiently and be able to tolerate drought better under some situations (Vu et al. 1998). Hence, soil water depletion in the root zone might occur at a lower rate than for plants growing under ambient CO<sub>2</sub> concentrations (Polley et al. 1994). A higher RWC (Relative Water Content) was reported in drought stressed plants under elevated CO<sub>2</sub>, rather than under ambient CO<sub>2</sub> in *Lotus corniculatus* (Carter et al. 1997) and *Panicum coloratum* (Seneweera et al. 2001). However, Seneweera et al. (2001) found that there was little difference between CO<sub>2</sub> treatments when the relative water content (RWC) was expressed as a function of soil water content. Thus, the conservation of soil water rather than osmotic adjustment would be what accounts for the greater water content of plants under elevated CO<sub>2</sub>, when the period of drought is similar. According to Goudriaan and Unsworth (1990), water use efficiency of plant canopy would increase by 33% if CO<sub>2</sub> concentration is doubled. However, Morrison and Mallett (1996) predicted a decrease of 15% in water use efficiency (WUE) by doubling the CO<sub>2</sub> concentration. So, there is a difference of opinion for the effect of increased CO<sub>2</sub> concentration on water use efficiency. The increase in WUE is caused by increased photosynthesis, rather than a reduction of water loss due to partially closed stomata. Thus, more biomass can be produced per unit of water used, although a crop would still require almost as much water from sowing to final

harvest. If temperatures rise, the increased WUE, as a result of CO<sub>2</sub> fertilization, could be diminished or negated, unless planting dates can be changed to more favorable seasons.

### F Crop Productivity

As far as worldwide production of major food crops is concerned, the increasing concentrations of CO<sub>2</sub> may have a significant effect on crop productivity due to increase in both the average surface temperature and the amount of CO<sub>2</sub> available for photosynthesis (Aggarwal 2003). In the absence of temperature increase, many studies have shown that the net effect of doubling of CO<sub>2</sub> is the increase in the yield of rice (Kim et al. 2003; Bouman and Van Laar 2006; Krishnan et al. 2007). The simulations by different models and many field experiments have shown the potential impact of climatic change and the variability in rice productivity (Baker et al. 1992c, Kim et al. 2003; Peng et al. 2004). Modeling studies from Bangladesh (Karim et al. 1996), Japan (Horie et al. 2000), China (Bachelet et al. 1995) and India (Mall and Aggarwal 2002) show country-wise variations in rice production, anticipated due to the climatic changes. The simulated yields increase when temperature increases are small, but decline when the decadal temperature increase is more than 0.8°C, with the greatest decline in crop yields occurring between the latitudes of 10°N and 35°N. A 3-year field experiment in Japan (Bannayan et al. 2005) with ORYZA 2000, where rice plants were subjected to elevated CO<sub>2</sub> with FACE under varying N fertilizer rates, showed that the proposed model over-estimated the increase in green leaf area indices due to the elevated CO<sub>2</sub> concentration but the enhancement of total biomass was only a minor over-estimation. While the model was successful in simulating the increase in rice yield due to the CO<sub>2</sub> enrichment, it failed to reproduce the observed interaction with N in the rice yield response to elevated CO<sub>2</sub> concentration. Thus, the lack of complete understanding of the effects and the potential interactions of environment variables on plant processes has, thus far, precluded definitive predictions of the effects of global climate change. A 'systems biology' approach is expected to provide better predictions. There are still arguments about whether or not elevated CO<sub>2</sub> enhances plant growth in C<sub>4</sub> species. Increased growth under elevated CO<sub>2</sub> has been

reported for a number of  $C_4$  species including maize and sorghum (Wong 1979; Poorter 1993; Amthor et al. 1994). However, others have found no effect (Hocking and Meyer 1991; Ziska et al. 1991; Ellis et al. 1995) or have found an effect only when  $CO_2$  enrichment was done under drought conditions (Samarakoon and Gifford 1996). Samarakoon and Gifford (1996) observed 35% more leaf area and 50% more dry matter due to the interactive effect of elevated  $CO_2$  and soil drought in maize. The well watered plants showed no significant growth effect. However, Wong (1979) demonstrated a 20% increase in dry matter production of maize grown at elevated  $CO_2$ , under irrigated conditions. Reported enhanced growth under elevated  $CO_2$  in  $C_4$  plants, like maize, has generally been attributed to increased WUE. However, there are reports of photosynthetic stimulation of  $C_4$  plants under elevated  $CO_2$ , although this enhancement may be limited to conditions where elevated  $CO_2$  ameliorates the mild drought stress effects (Samarakoon and Gifford 1996). Brown and Rosenberg (1997), while modeling yield prediction, observed that high temperature induced reduction in grain yield in five crops including maize and sorghum were to some extent mitigated by elevated  $CO_2$  and increased precipitation. The mitigation was most pronounced in sorghum. Singh et al. (1998) suggested that the increasing  $CO_2$  level would increase maize and sorghum yields in Quebec, Canada by 20%. Despite various differences on the impact of climate change on maize yield, as predicted by various models, Young and Long (2000) suggested a reduction in maize yield for all climate change scenarios. On the contrary, Leakey et al. (2004) observed that the growth at elevated  $CO_2$  significantly increased leaf photosynthetic  $CO_2$  uptake rate by up to 41% and accounted it with greater intercellular  $CO_2$ , lower stomatal conductance and lower transpiration. These results call for a reassessment of the established view that  $C_4$  photosynthesis are insensitive to elevated  $CO_2$  under favorable growing conditions and the production potential of maize will not be affected by global rise in  $CO_2$ .

### III High Temperature

According to recent IPCC (Intergovernmental Panel on Climate Change) report, a warming of about  $0.2^\circ C$  per decade is projected for the next

two decades for a range of SRES (Special Report on Emission Scenarios). Even if the concentrations of all GHG's and aerosols had been kept constant at year 2000 levels, a further warming of about  $0.1^\circ C$  per decade would be expected. Afterwards, temperature projections increasingly depend on specific emissions scenarios (IPCC 2007). Since industrialization, the Earth's surface temperature has increased by  $0.6^\circ C$ , mainly due to changes in  $CO_2$  concentration and other greenhouse gases during that period (Stott et al. 2000). By 2050s, average air temperatures, relevant to rocky coastal platforms, are predicted to be up by  $2.1^\circ C$  than in 2000 (Hiscock et al. 2004). Sea surface temperatures may be up by  $2.5^\circ C$  higher than in 2000 (Hiscock et al. 2004). Temperature effects on the rates of biochemical reactions may be modeled as the product of two functions, an exponentially increasing rate of the forward reaction and an exponential decay resulting from enzyme denaturation as temperatures increase (Fig. 2). High temperature also results in desiccation and disturbs the delicate balance between photosynthesis and respiration. Once the temperature exceeds the maximum up to which growth takes place, the plant then enters the state of quiescence. Leaves lose their green color and are not able to perform photosynthesis. When temperature becomes very high, a lethal level is reached. At temperatures higher than the optimal cardinal, the physiological activity declines as a consequence of inactivation of enzymes. Apart from desiccation, disturbed photosynthesis

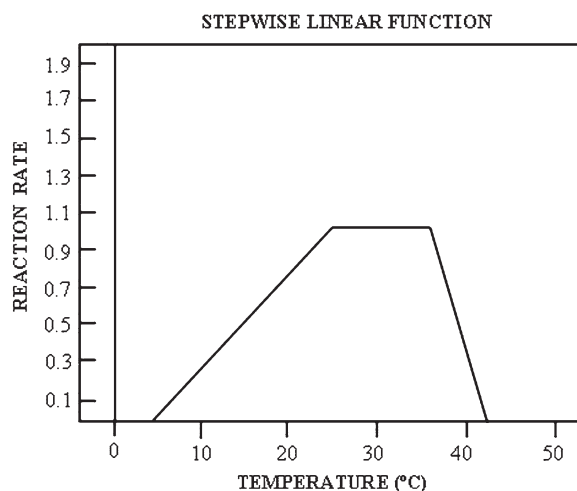

Fig. 2. Stepwise increase in reaction rate as a function of temperature (Adapted from Abrol and Ingram 1996).

and respiration imbalance, plants are injured in several ways, such as excessive respiration in seeds, sun clad and stem girdle.

The greatest concern is whether it is possible to increase the upper limit of enzyme stability to prevent denaturation. Failure of only one critical enzyme system can cause death of an organism. This fact may explain why most crop species survive sustained high temperatures up to a relatively narrow range, 40°C to 45°C. The relationship between the thermal environment for an organism and the thermal dependence of enzymes has been well established (Senioniti et al. 1986). The thermal dependence of the apparent reaction rate for selected enzymes may indicate the optimal thermal range for a plant. The range over which the apparent Michaelis-Menten constant ( $K_m$ ) for CO<sub>2</sub> is minimal and stable is termed the thermal kinetic window (Mahan et al. 1987). For crop plants, the thermal kinetic window (TKW) is generally established as a result of thermally induced lipid phase changes, RuBisCo activity and the starch synthesis pathway in leaves and reproductive organs (Burke 1990). In cotton and wheat, the time during which foliage temperature remained within the TKW was related to dry matter accumulation (Burke et al. 1988). The cumulative time that rain-fed crop foliage is outside the TKW provides an index of the degree of extreme temperature stress of the environment.

### A Oxidative Stress

Heat stress may be an oxidative stress (Lee et al. 1983). Per-oxidation of membrane lipids has been observed at high temperatures (Upadhyaya et al. 1990; Mishra and Singhal 1992), which is a symptom of cellular injury. Enhanced synthesis of an antioxidant by plant tissues may increase cell tolerance to heat (Upadhyaya et al. 1990, 1991) but no such antioxidant has been positively identified. A relationship between lipid composition and incubation temperature has been shown for algae, fungi and higher plants. In *Arabidopsis*, exposed to high temperatures, total lipid content decreases to about one-half and the ratio of unsaturated to saturated fatty acids decreases to one-third of the levels at temperatures within the TKW (Somerville and Browse 1991). Increase in saturated fatty acids of membranes increases

their melting temperature and thus confers heat tolerance. An *Arabidopsis* mutant, deficient in activity of chloroplast fatty acid W-9 desaturase, accumulates large amounts of 16:0 fatty acids, resulting in greater saturation of chloroplast lipids. This increases the optimum growth temperature (Raison 1986; Kunst et al. 1989). In cotton, however, heat tolerance does not correlate with degree of lipid saturation (Rikin et al. 1993) and similar differences in genotypic differences in heat tolerance could not be related to membrane lipid saturation in other species (Kee and Nobel 1985). In such species, a factor other than membrane stability may be limiting growth at high temperature.

### B Photosynthesis

1°C to 2°C increase in average temperature is not likely to have a substantial impact on leaf photosynthetic rates. While photosynthetic rates were found to be temperature-sensitive in other crops, wheat and rice appear to be different. In wheat, no measurable differences were found in photosynthetic rates per unit flag leaf area or on a whole-plant basis in the temperature range from 15°C to 35°C (Bagga and Rawson 1977). In rice, there is little temperature effect on leaf carbon dioxide assimilation from 20°C to 40°C (Egeh et al. 1994). Research has shown that there is a significant variation among wheat cultivars with respect to reduction in photosynthesis at very high temperature. Photosynthesis of germplasm adapted to higher temperature environments was less sensitive to high temperature than was germplasm from cooler environments (Al-Khatib and Paulsen 1990). When this germplasm was grown under moderate (22°C/17°C) and high (32°C/27°C) temperatures in the seedling stage or from anthesis to maturity, there was a highly significant correlation between photosynthesis rate and either seedling biomass ( $r=0.943^{***}$ ) or grain yield of mature plants ( $r = 0.807^{**}$ ). Genotypes, most tolerant to high temperatures, had the most stable leaf photosynthetic rates across temperature regimes or they had the longest duration of leaf photosynthetic activity after anthesis and high grain weights. The above relationship was exemplified by 'Ventnor', from the high temperature area of Australia, and 'Lancero', from the high altitude area of Chile (Table 2).

*Table 2.* Mean weekly photosynthetic rate ( $\mu\text{mol CO}_2 \text{ m}^{-2} \text{ s}^{-1}$ ) and duration of photosynthetic activity (weeks, in parentheses), and grain biomass of two wheat genotypes grown at two temperature regimes. Figures in parentheses give duration of photosynthetic activity (in weeks) from anthesis to physiological maturity.

Genotype	Seedlings after 2 weeks of treatment		From anthesis to maturity		Grain biomass (g/tiller)	
	22°C/17°C	32°C/27°C	22°C/17°C	32°C/27°C	22°C/17°C	32°C/27°C
Ventor	8.6	7.0	6.4 (7)	5.3 (7)	0.93	0.80
Lancero	7.9	4.6	4.1 (10)	3.1 (7)	0.43	0.28

Source: Al-Khatib and Paulsen 1990.

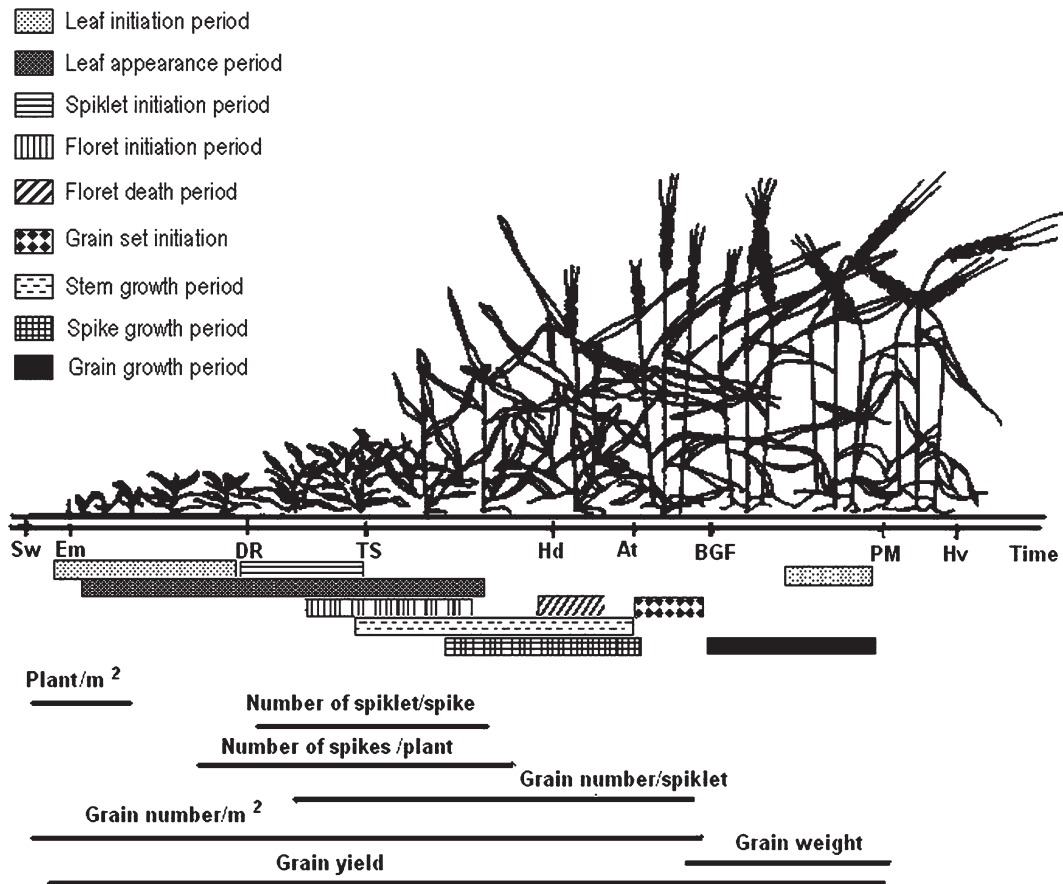

*Fig. 3.* Schematic diagram of wheat growth and development, showing the stages of sowing (Sw), emergence (Em), first double ridge appearance (DR), terminal spikelet appearance (TS), heading (Hd), anthesis (At), beginning of the grain-Filling period (BGF), physiological maturity (PM), and harvest (Hv). Patterned boxes indicate the period of differentiation or growth of specific organs. Bars represent the periods of development when different components of grain yield are produced. Heavy lines refer to main shoots and light lines represent extension associated with tillers (Adapted from Abrol and Ingram 1996).

### C Crop Phenology

In the past 30–40 years, the sequence of pre-anthesis phenological events has been critically assessed with respect to grain yield potential and sensitivity to weather variables, particularly prevailing temperature and day length. Several systems have been used to classify the sequence

of phenological events. Abrol and Ingram (1996) identified five phenological stages of wheat, which are as follows (Fig. 3):

- Germination – seeding to seedling emergence
- Canopy development – emergence to first spikelet initiation, the double ridge stage
- Spikelet production – first spikelet initiation to terminal spikelet formation



**Table 3.** Response of phasic development to temperature photoperiod and vernalization. For the estimation of sensitivity, the total life span was divided into the stages shown in Fig. 3. An arbitrary scale was used to show when the effects are strong (++++), moderate (+++) or slight (+). 0 denotes that the factor does not affect the process and question marks refer to uncertainties in the literature. For each factor, genetic variation in response was considered.

Developmental phase	Temperature	Photoperiod	Vernalization
Sowing-emergence	++++/++++	0	0
Emergence-double ridges	+++/++++	0/+++	0/++++
Double ridges-terminal spikelet	+/+++	0/++++	0/++++
Terminal spikelet-heading	+++/++++	0/+++	0/(?)
Heading-anthesis	+++/++++	0/(?)	0
Anthesis-maturity	+++/++++	0	0

Source: Abrol and Ingram 1996.

- Spikelet development – terminal spikelet formation to anthesis
- Grain development – anthesis to maturity

All these phenological stages are sensitive to temperature. Table 3 summarizes the effects of temperature on the time duration needed from sowing or emergence to heading under controlled environment and field conditions. Unfortunately, few experiments have been conducted with enough cultivars to assess the genetic variability in this trait. The major conclusions from these studies are:

- All genotypes are sensitive to temperature at one stage or another; temperature sensitivity, however, varies greatly with the genotype.
- Phenological stages differ in sensitivity to temperature.
- The duration of phase from sowing to first spikelet initiation is less sensitive to change in temperature than are other phases, although genotypes do differ in thermo tolerance during this phase.

The stages during which environment has the greatest impact on yield are from first spikelet initiation or terminal spikelet formation until anthesis. Spikelet number and floral number (potential grain number), both dominant yield contributing attributes, are established during these phases. Grain weight, on the other hand, appears to be much less sensitive to heat stress than is grain number.

**Thermal Tolerance** – The hypothesis that high temperature induces spikelet injury was evaluated by enhancing the tolerance level in several crop models (Krishnan et al. 2007). The equation used in the ORYZA1 model to describe the response of spikelet fertility to temperature is given as:

$$\delta = \frac{100}{\left[ 1 + e^{0.853(T_{\max} - T_{mp})} \right]}$$

where,  $\delta$  is the fertility percentage,  $T_{\max}$  the average daily maximum temperature ( $^{\circ}\text{C}$ ) during the flowering period and  $T_{mp}$  the average daily maximum temperature ( $^{\circ}\text{C}$ ) at which 50% of the spikelets are fertile. For the *Indica* variety,  $T_{mp}$  had a value of 36.5. To simulate the possible effect of an increase in tolerance of spikelet to high temperatures, it was assumed that this response was shifted by  $2^{\circ}\text{C}$  by increasing the value of  $T_{mp}$  to  $38.5^{\circ}\text{C}$ . This adaptation in the spikelet trait was examined at a site in Cuttack (Orissa, India). With the available weather data for this site, and with a constant sowing date of June 15, a comparative study using the ORYZA1 model was made for the current climate and other general circulation models (GCM) scenarios as obtained by the Geophysical Fluid Dynamics Laboratory (GFDL), Goddard Institute for Space Studies (GISS) and UK Meteorological Office (UKMO). Under the GCM scenarios, temperature at the time of flowering for the main season was already high. Without any temperature tolerance of the variety by not adjusting the value of  $T_{mp}$ , large decreases in yield due to spikelet sterility were predicted. But with the adaptation of variety by improved temperature tolerance of the spikelet, the yield increased higher than that of the current scenario level, at about +10.7, +13.6 and  $-8.4$  under the GFDL, GISS and UKMO model scenarios, respectively. Synthesis and accumulation of proteins were ascertained during a rapid heat stress. These were designated as ‘heat shock proteins’ (HSPs). Subsequently, it was shown that increased production of these proteins also occurs when plants

experience a gradual increase in temperature more typical of that experienced in a natural environment. Three classes of proteins as distinguished by molecular weight account for most HSPs, namely HSP90, HSP70 and low molecular weight proteins of 15–30 kDa (LMW HSP). The proportions of the three classes differ among species. In general, heat shock proteins are induced by heat stress at any stage of development. Under maximum heat stress conditions, HSP70 and HSP90 mRNAs can increase tenfold and LMW HSP as much as 200-fold. Three other proteins, though less important, are also considered to be heat shock proteins, that is, 110 kDa polypeptides, ubiquitin and GroEL proteins. Correlation between synthesis and accumulation of heat shock proteins and heat tolerance suggests, but does not prove, that the two are causally related. Further evidence for a causal relationship is that some cultivar differences in heat shock protein expression correlate with differences in thermotolerance. In genetic experiments, heat shock protein expression co-segregates with heat tolerance. Another evidence for the protective role of heat shock protein is that mutants unable to synthesize heat shock proteins and cells in which HSP70 synthesis is blocked or inactivated, are more susceptible to heat injury. HSPs provide a significant opportunity to increase heat tolerance of crops.

#### D Crop Productivity

In experiments under controlled conditions from 25°C to 35°C, mean grain weight declined by 16% for each 5°C increase in temperature (Asana and Williams 1965). In pot experiments, grain yield decreased by 17% for each 5°C rise (Wattal 1965). For every 1°C rise in temperature, there is a depression in grain yield by 8–10%, mediated through 5–6% fewer grains and 3–4% smaller grain weight. To elucidate the causal factor for reduced grain filling in wheat because of higher temperatures, Wardlaw (1974) studied three main components of the plant system:

- Source – flag leaf blade
- Sink – ear
- Transport pathway – peduncle

Wardlaw (1974) observed that photosynthesis had a broad temperature optimum from 20°C to

30°C, with photosynthesis declining rapidly at temperatures above 30°C. The rate of <sup>14</sup>C assimilate movement out of the flag leaf, phloem loading, was optimum around 30°C, while the rate of <sup>14</sup>C assimilate movement through the stem was independent of temperature from 1°C to 50°C. Thus, in wheat, temperature effects on translocation result indirectly from direct temperature effects on source and sink activities. Reduction of grain weight by heat stress may be explained mostly by effects of temperature on the rate and the duration of grain growth. As temperature increased from 15°C/10°C to 21°C/16°C, duration of grain filling was reduced from 60 to 36 days and grain growth rate increased from 0.73 to 1.49 mg/grain/day, with minimal influence on grain weight at maturity. Further increase in temperature from 21°C/16°C to 30°C/25°C resulted in decline in grain filling during 36 to 22 days with a minimal increase in grain growth rate from 1.49–1.51 mg/grain/day. Thus, mature grain weight was significantly reduced at the highest temperature.

Research on the effects of brief periods of ear warming after anthesis on ear metabolism have identified differential responses of starch and nitrogen accumulation in grain of four wheat cultivars (Bhullar and Jenner 1983, 1985, 1986; Jenner 1991a, b; Hawker and Jenner 1993). Warming increased the rate of dry matter accumulation in all the cultivars but the increase was less in cv. Aus 22,645 than in the other cultivars studied. Rate of increase in nitrogen accumulation was, however, higher than the increase in total dry matter accumulation. Under long-term exposure to heat stress, increased grain nitrogen concentration is almost entirely as a result of decreased starch content rather than a change in total grain quality (Bhullar and Jenner 1985). The conversion of sucrose to starch within the endosperm is decreased by elevated temperatures. Furthermore, heat stress effects on final grain weight were associated with reduced levels of soluble starch synthetase activity (Hawker and Jenner 1993).

To summarize, high temperature reduction of grain yield results from:

- Reduced numbers of grains formed
- Shorter grain growth duration
- Inhibition of sucrose assimilation in grains

#### IV Ultraviolet Radiation

Over the last decade, a decrease of stratospheric ozone was observed at all latitudes (about 10% in winter, 0% during summer and intermediate values during spring and autumn). However, the 'Biological Action Factor' of UV-B can vary over several orders of magnitude with even slight changes in the amount and wavelength of UV-B. Surface-level UV-B radiation (280–320 nm) and ozone ( $O_3$ ) are components of the global climate and any increase in their levels can lead to adverse effects on crop growth and productivity on a broad geographic scale (Krupa and Kickert 1993). Possible increases in surface UV-B radiation are attributed to the depletion of the beneficial stratospheric  $O_3$  layer (Cicerone 1987). On the other hand, increases in surface-level  $O_3$ , which in many regions are largely the result of photochemical oxidant pollution, are also part of the general increase in the concentrations of the so-called 'greenhouse' gases (e.g., carbon dioxide, methane, nitrous oxide, and chlorofluorocarbons) that may lead to global warming. In the context of climate change, it is therefore important to maintain a holistic view and recognize that UV-B and  $O_3$  levels at the surface are only parts of the overall system of atmospheric processes and their products (Runeckles and Krupa 1994). There has been no global network for monitoring surface-level UV-B radiation. Long-term UV-B data are sparse and not very reliable. Nevertheless, numerous investigators have examined the effects of UV-B radiation on crops in artificial exposures, but large uncertainties in the relevance to climate change of much of the information obtained remain. According to Runeckles and Krupa (1994), the transfer of results from growth chamber or greenhouse experiments to the ambient environment has been particularly difficult. This appears to be due to the differences in the characteristics of plants grown under these environments and to photo-repair under the high photosynthetic photon flux densities encountered in the ambient environment. Studies of the effects of UV-B on physiological processes such as photosynthesis and on modes of action are appropriately examined under controlled environment conditions. However, the integration of their effects on the processes affected within the whole organism that ultimately lead to growth can only reliably be

investigated using plants growing under true field conditions. Our knowledge of the effects of  $O_3$  is also beset by uncertainties related largely to the lack of information about plant responses under such field conditions. Here the problem is not one of interrelating growth and field observations, but concerns the relevance of the results from the most frequently used open-top exposure chamber method. There is no question of the phytotoxicity of  $O_3$ . However, the results obtained in many studies of its effects are primarily supported by controversial statistical techniques (Kickert and Krupa 1991) and, therefore, the fact remains that the results cannot be validated and show considerable variability from season to season and from location to location, most likely because of the different types of experimental designs used. Perhaps, the most pressing need at the moment is to obtain field information about the effects of UV-B and  $O_3$  that are clearly identified with one or more of the different scenarios outlined in Table 4. To such studies, we should consider adding elevated levels of  $CO_2$  in view of the preliminary observations that indicate significant interaction with the effects of  $O_3$ . While such information is needed for direct effects on crop species, the studies must also include information about the possible long-term effects on growth, joint effects with other pollutants, incidence of pathogens and insect pests, intra-species competition, and crop-weed relationships (Krupa and Kickert 1993; Runeckles and Krupa 1994). Such studies, we hope, would also permit the acquisition of information about the processes involved, such as the partitioning of assimilates and the induction of morphological changes. In contrast to these gross mechanisms affecting growth and development, ongoing studies at the biochemical and metabolic level are needed in order to provide a sound understanding of the fine mechanisms involved. In view of the evidence that suggests that UV-B has little adverse effect on photosynthesis or growth under field conditions, it appears that the concern over increases in UV-B irradiation, resulting from stratospheric  $O_3$  depletion, should focus on longer-term effects probably involving the consequences of damage to nucleic acids. In contrast, increased tropospheric  $O_3$  levels will undoubtedly have immediate adverse effects on most species, independent of any longer-term effects brought about by either

Table 4. Effects of elevated surface-level UV-B radiation and O<sub>3</sub> on crops.

Plant characteristic	Elevated UV-B	Elevated O <sub>3</sub>
Photosynthesis	Reduced in many C <sub>3</sub> and C <sub>4</sub> species (at low light intensities)	Decreased in most species
Leaf conductance	Reduced (at low light intensities)	Decreased in sensitive species and cultivars
Water-use efficiency	Reduced in most species	Decreased in sensitive species
Leaf area	Reduced in many species	Decreased in sensitive species
Specific leaf weight	Increased in many species	Increased in sensitive species
Crop maturation rate	Not affected	Decreased
Flowering	Inhibited or stimulated	Decreased floral yield, fruit set and yield, delayed fruit set
Dry matter production and yield	Reduced in many species	Decreased in most species
Sensitivity between cultivars (within species)	Response differs between cultivars	Frequently large variability
Drought stress sensitivity	Plants become less sensitive to UV-B, but sensitive to lack of water	Plants become less sensitive to O <sub>3</sub> but sensitive to drought
Mineral stress sensitivity	Some species become less while others more sensitive to UV-B	Plants become more susceptible to O <sub>3</sub> injury

Source: Runeckles and Krupa 1994.

adaptation or genetic selection. In view of the urgency of acquiring information on the potential impacts of the various components of climatic change, including UV-B and tropospheric O<sub>3</sub>, that can be realistically envisioned, every effort should therefore be made to avoid wasting research effort and resources on studies that will do nothing to reduce the uncertainties associated with our present information, and which fail to recognize the potential importance of the interactions among the various components (Runeckles and Krupa 1994).

## V Tropospheric Ozone

Tropospheric ozone originates about half from photochemical reactions involving nitrogen oxides (NO<sub>x</sub>), methane or carbon monoxide, and half by downward movement of stratospheric ozone. Ozone is a highly phytotoxic compound causing negative effects on a number of plant processes, including photosynthesis, water-use efficiency, timing of senescence, dry matter production and yield (Sandermann 1996; Heath and Taylor 1997; Pell et al. 1997; Krupa et al. 2000). The reduced 'vitality' caused by ozone-exposure can render plants more susceptible to pathogens (Sandermann 2000), as has been described

mainly for necro-trophic fungi (Heagle and Key 1973; Manning and von Tiedemann 1995). On the other hand, ozone can also induce resistance responses in plants comparable to elicitor- and pathogen-induced reactions (Ernst et al. 1992; Eckey-Kaltenbach et al. 1994; Kangasjärvi et al. 1994; Yalpani et al. 1994; Sandermann et al. 1998). For this reason, pre-exposure of plants to ozone can also induce a resistance to subsequent infection by pathogens (Sharma et al. 1996; Rao et al. 2000).

## VI Biotic Stress

In the event of climate change, it is of great importance to understand how this change will affect the growth of plants and their susceptibility towards pathogens. Potato (*Solanum tuberosum* L. cv. Indira) plants, with high susceptibility to the late blight pathogen, *Phytophthora infestans*, were exposed for 4 weeks to two different CO<sub>2</sub> concentrations (400 and 700 ppm) combined with ambient and double ambient ozone concentrations (first experiment) and with 1/5 ambient and ambient ozone concentrations (second experiment) in climate chambers (Plessi et al. 2007). Leaves of the potato were then inoculated with *Phytophthora infestans* zoospores. Plants from



the “high CO<sub>2</sub>” variant showed a significantly increased resistance to the pathogen, verified by visual evaluation and quantitative real-time PCR, whereas, plants treated with double ambient ozone were slightly more susceptible. An increase in the constitutive activities of the pathogenesis-related (PR)-proteins  $\beta$ -1,3-glucanase and osmotin in leaves of plants exposed to 700 ppm CO<sub>2</sub> correlated with the increase in resistance at this CO<sub>2</sub>-concentration. Biomass parameters were barely affected by the elevated CO<sub>2</sub>-concentration, but decreased with increasing ozone concentrations. Biochemical analyses revealed that the content of starch, as well as the content of soluble sugars, in leaves was highest at the double ambient ozone/700 ppm CO<sub>2</sub> variants pointing to an ozone-induced inhibition of assimilate allocation from leaves to tubers. Leaf C/N-ratio increased at elevated CO<sub>2</sub>-concentrations due to a decrease in N-content. Regional vulnerability was depicted in case of pest infection with climate changes by a number of researchers. Reports from the South Asia indicated substantial improvement in spot blotch resistance on key cultivars commercially grown in India (Bhushan et al. 2002), Bangladesh (Siddique et al. 2006) and Nepal (Sharma and Duveiller 2006). Besides, a number of genotypes were recently identified to carry high and stable foliar blight resistance which is presently used in the wheat breeding programs in the Eastern Gangetic Plains (EGP) of India (Sharma et al. 2004). However, yield trials conducted by breeding centers show that wheat yields in the EGP region are actually decreasing (Sharma et al. 2007). This apparently parallels wheat production statistics of the regional yields which are reported to be either stagnant or slightly decreasing, except in Nepal (FAO 2006). Further evidence supporting this observation is that due to lower production, India imported 3 million tonnes of wheat in 2006, which contrasts with the optimism that followed the green revolution and raises concerns among agricultural policy makers regarding prospects of self-sufficient staple food production in the near future (Nagarajan 2005). Stagnant or lower wheat yields in recent years in the plains of South Asia is considered partly due to climatic factors including heat stress characterized by an increasing trend in average temperature during winter months (Rane et al. 2000; Nagarajan 2005;

Black et al. 2006; Sharma et al. 2007). Another factor causing decline in wheat productivity in rice–wheat system, the most dominant cropping system in India, is related to soil fertility and fertilizer use (Nagarajan 2005). Nagarajan (2005) has also listed socio-economic and policy related factors being responsible for recent decline in wheat production in the Indo-Gangetic plain. A steady increase of mean March temperature was observed at five sites in the EGP region in the past 6 years (Sharma et al. 2007). Since high temperatures also aggravate spot blotch severity (Nema and Joshi 1973; Sharma and Duveiller 2004; Duveiller et al. 2005) wheat yield losses in the EGP region could be due to increase in spot blotch epidemic over the recent years, which could curtail the benefits from progress recently achieved by local breeders toward incorporating resistance in locally adapted high yielding varieties. Hence, increased spot blotch severity due to steadily changing climatic conditions would worsen the damage already caused by heat with the reduction of assimilates translocated to the grain. Likewise, climatic change in South Asia has been observed in terms of a significantly increasing number in cloudy and foggy days during winter months (Debi 2003), which not only reduces solar radiation use but also contributes to prolonged hours of 100% relative humidity in crop canopy, an ideal situation for early establishment of spot blotch in wheat. Limited data recorded with the help of a data logger installed in a wheat field confirms this prolonged periods of high relative humidity in the canopy (de Lespinay 2004).

## VII Conclusions and Future Prospects

Climate variables can have significant impacts on agricultural production. These variables are atmospheric CO<sub>2</sub>, temperature, precipitation and evapo-transpiration. Crop response to changes in these factors is the first stage in the cascade of consequences leading to potentially profound changes in the agricultural economy of entire regions. The role of CO<sub>2</sub> in agriculture is complex in that it can be positive in some respects and negative in other respects. CO<sub>2</sub> concentration affects crop production directly by influencing the physiological processes of photosynthesis

and transpiration; therefore, it has the potential to stimulate plant growth. The magnitude of that stimulation will vary greatly among species of differing photosynthetic pathway, and it will depend on the growth stage and on the water and nutrient status. Simultaneously, other agents of climate change, such as rising temperature, increased UV-B, ozone depletion and biotic stress directly or indirectly affect the plant physiological processes, leading to reduced agricultural productivity. All these changes, in concert, could have a major impact on the prospects of food security. Physiological research on the responses of plants to changing levels of key factors of production is complicated by the fact that these variables are likely to change simultaneously. We also need to improve our understanding of the interactions of CO<sub>2</sub> and temperature, and precipitation with other environmental factors such as tropospheric ozone and UV-B radiation.

Within the current framework, however, additional sensitivity analyses need to be done which could provide a more comprehensive picture of alternative assumptions for various plant designs. Monitoring and early warning systems need to be designed to reduce several uncertainties and to produce a clearer picture of the vagaries of climate change. Projections of technological changes and better policy on climate change can prove to be a critical factor in analyzing the future alternatives. New technologies and plant designs need to be developed and adopted commercially. Adaptive conservation strategies should be proposed to facilitate resilience to climate change like conserving topographic diversity or conserving processes to ensure future evolutionary potential. Studies need to be undertaken on a global, and collaborative, scale; International agencies, like IPCC, can play a constructive role in this endeavor as then only likely regional climate change, and also the rate and extent of species responses, can be understood.

### Acknowledgements

YPA and HD gratefully acknowledge the financial support from Indian National Science Academy and the Council of Scientific and Industrial Research, India.

### References

- Abrol YP, Ingram KT (1996) Effects of elevated CO<sub>2</sub> and temperature on growth and yields of some crop plants. In: Bazzaz F, Sombroek W (eds) Global climate change and agricultural production. Wiley, New York, pp 123–140
- Abrol YP, Watal PN, Gnanm A, Govindjee, Ort DR, Teramura AH (eds) (1991) Impact of global climatic changes on photosynthesis and plant productivity. Proc Indo-US Workshop, Oxford & IBH Publishing Co., New Delhi, p 872
- Aggarwal PK (2003) Impact of climate change on Indian agriculture. *J Plant Biol* 30:189–198
- Al-Khatib K, Paulsen GM (1990) Photosynthesis and productivity during high temperature stress of wheat genotypes from major world regions. *Crop Sci* 30:1127–1132
- AllenLHJr, VuJCV, ValleRR, BooteKJ, JonesPH (1988) Non-structural carbohydrates and nitrogen of soybean grown under carbon dioxide enrichment. *Crop Sci* 28:84–94
- Amthor JS (1994) Respiration and carbon assimilation use. In: Boot KJ, Bennett JM, Sinclair TR, Paulsen GM (eds) Physiology and determination of crop yield. American Soc Agron, Madison, WI, pp 221–250
- Amthor JS (1997) Plant respiratory responses to elevated carbon dioxide concentration. *Field Crops Res* 73:1–34
- Amthor JS, Mitchell RJ, Runion GB, Rogers HH, Prior SA, Wood CW (1994) Energy content, construction cost and phytomass accumulation of *Glycine max* L. Merr and *Sorghum bicolor* L. Moench grown in elevated CO<sub>2</sub> in the field. *New Phytol* 128:443–450
- Araus JL, Slafer GA, Reynolds MP, Royo MAJ (2002) Plant breeding and drought in C<sub>3</sub> cereals: what should we breed for? *Ann Bot* 89:925–940
- Asana RD, Williams RF (1965) The effect of temperature stress on grain development in wheat. *Aust J Agric Res* 16:1–13
- Bachelet D, Kern J, Tolg M (1995) Balancing the rice carbon budget in China using spatially-distributed data. *Ecol Model* 79:167–177
- Bagga AK, Rawson HM (1977) Contrasting responses of morphologically similar wheat cultivars to temperatures appropriate to warm temperate climates with hot summers: a study in controlled environment. *Aust J Plant Physiol* 4:877–887
- Baker JT, Laugel R, Boote KJ, Allen LH Jr (1992a) Effects of daytime carbon dioxide concentration on dark respiration of rice. *Plant Cell Environ* 15:231–239
- Baker JT, Allen LH Jr, Boote KJ (1992b) Temperature effects on rice at elevated CO<sub>2</sub> concentration. *J Exp Bot* 43:875–1000
- Baker JT, Allen LH Jr, Boote KJ (1992c) Response of rice to CO<sub>2</sub> and temperature. *Agric For Meteorol* 60:153–166
- Bannayan M, Kobayashi K, Kim H, Lieffering M, Okada M, Mirza S (2005) Modelling the interactive

- effects of atmospheric CO<sub>2</sub> and N on rice growth and yield. *Field Crops Res* 93:237–251
- Bhullar SS, Jenner CF (1983) Responses to brief periods of elevated temperatures in ears and grain of wheat. *Aust J Plant Physiol* 10:549–560
- Bhullar SS, Jenner CF (1985) Differential responses to high temperature of starch and nitrogen accumulation in the grain of four cultivars of wheat. *Aust J Plant Physiol* 12:313–325
- Bhullar SS, Jenner CF (1986) Effect of a brief episode of elevated temperature on grain filling in wheat ears cultured on solution of sucrose. *Aust J Plant Physiol* 13:617–626
- Bhushan B, Singh K, Kaur S, Nanda GS (2002) Inheritance and allelic relationship of leaf blight resistance genes in three bread wheat varieties in the adult plant stage. *Genet Plant Breed* 56:69–76
- Black TA, Chen WJ, Barr AG, Arain MA, Chen Z, Nestic Z, Hogg EH, Bouman BAM, Van Laar HH (2006) Description and evaluation of rice growth model ORYZA 2000 under nitrogen limited conditions. *Agric Syst* 87:249–273
- Bloom AJ, Smart DR, Nguyen DT, Searles PS (2002) Nitrogen assimilation and growth of wheat under elevated carbon dioxide. *Proc Nat Acad Sci USA* 99:1730–1735
- Bouman BAM, Van Laar HH (2006) Description and evaluation of rice growth model ORYZA 2000 under nitrogen limited conditions. *Agric Syst* 87:249–273
- Brown RA, Rosenberg NJ (1997) Sensitivity of crop yield and water use to change in a range of climatic factors and CO<sub>2</sub> concentrations: a simulation study applying EPIC to the central USA. *Agric Fores Meteor* 83:171–203
- Bunce JA (1998) Effect of humidity on short-term responses of stomatal conductance to an increase in carbon dioxide concentration. *Plant Cell Environ* 21:115–120
- Burke JJ (1990) High temperature stress and adaptation in crops. In: Alscher RG, Cummings JR (eds) *Stress response in plants: adaptation and acclimation mechanisms*. Wiley-Liss, New York, pp 295–309
- Burke JJ, Mahan JR, Hatfield JL (1988) Crop specific thermal kinetic windows in relation to wheat and cotton biomass production. *Agron J* 80:553–556
- Carter EB, Theodorou MK, Morison P (1997) Responses of *Lotus corniculatus* to environmental change. *New Phytol* 136:245–253
- Chaves M (2002) Water stress in the regulation of photosynthesis in the field. *Ann Bot* 89:907–916
- Cicerone RJ (1987) Changes in stratospheric ozone. *Science* 237:35–42
- Conroy JP (1992) Influence of elevated atmospheric CO<sub>2</sub> concentrations on plant nutrition. *Aust J Bot* 40:445–456
- de Lespinay A (2004) Selection for stable resistance to *Helminthosporium* leaf blights in non-traditional warm wheat areas. MS thesis, Université Catholique de Louvain, Louvain-La-Neuve
- Debi S (2003) The dark white shroud Himal South Asian. <http://www.himalmag.com/2003/march/essay.htm>
- Drake BG (1992) The impact of rising CO<sub>2</sub> on ecosystem production. *Water Air Soil Pollut* 64:25–44
- Duveiller E, Kandel YR, Sharma RC, Shrestha SM (2005) Epidemiology of foliar blights (spot blotch and tan spot) of wheat in the plains bordering the Himalayas. *Phytopathology* 95:248–256
- Eckey-Kaltenbach H, Großkopf E, Sandermann H, Ernst D (1994) Induction of pathogen defence genes in parsley (*Petroselinum crispum* L.) plants by ozone. *Proc Royal Soc Edinb* 102B:63–74
- Egeh AO, Ingram KT, Zamora OB (1994) High temperature effects on leaf exchange. *Phil J Crop Sci* 17:21–26
- Ellis RH, Craufurd PQ, Summerfield RJ, Roberts EH (1995) Linear relationship between carbon dioxide concentration and rate of development towards flowering in sorghum, cowpea and soybean. *Ann Bot* 75:193–198
- Eriksson M, Villand P, Garderstrom P, Samuelsson G (1998) Induction and regulation of expression of a low-CO<sub>2</sub>-induced mitochondrial carbonic anhydrase in *Chlamydomonas reinhardtii*. *Plant Physiol* 116:637–641
- Ernst D, Schraudner M, Langebartels C, Sandermann H (1992) Ozone-induced changes of mRNA levels of  $\beta$ -1,3-glucanase, chitinase and pathogenesis-related protein 1b in tobacco plants. *Plant Mol Biol* 20:673–682
- FAO (2006) Statistical database. <http://www.fao.org>. Cited 4 Feb 2006
- Foyer C, Noctor G (eds) (2002) *Photosynthetic nitrogen assimilation and associated carbon and respiratory metabolism, advances in photosynthesis and respiration*, vol. 12 (series editor, Govindjee). Springer, Dordrecht
- Goudriaan J, Unsworth MH (1990) Implications of increasing carbon dioxide and climate change for agricultural productivity and water resources. In: Kimball BA, Rosenberg NR, Allen LH Jr (eds) *Impact of carbon dioxide, trace gases and climate change on global agriculture*, special publication number 53. American Society of Agronomy, Madison, WI, pp 291–297
- Gray JE, Holroyd GH, van der Lee FM, Bahrami AR, Sijmons PC, Woodward FI, Schuch W, Hetherington AM (2000) The HIC signalling pathway links CO<sub>2</sub> perception to stomatal development. *Nature* 408:713–716
- Hall AE, Allen LH Jr (1993) Designing cultivars for the climatic conditions of the next century. In: Buxton DR, Shibles R, Forsberg RA, Blad BL, Asay KH, Paulsen GM, Wilson RF (eds) *International crop science*. Crop Science Society of America, Madison, WI, pp 291–297
- Hawker JS, Jenner CF (1993) High temperature effects on the activity of enzymes in the committed pathway of starch synthesis in developing wheat endosperm. *Aust J Plant Physiol* 20:197–200
- Heagle AS, Key LW (1973) Effect of ozone on the wheat stem rust fungus. *Phytopathology* 63:397–400
- Heath RL, Taylor GE (1997) Physiological processes affecting plant responses to ozone exposure. In: Sandermann H, Wellburn AR, Heath RL (eds) *Forest decline and ozone: a*

- comparison of controlled chamber and field experiments. Springer, New York, pp 317–368
- Hiscock K, Southward A, Tittley I, Hawkins S (2004) Effects of changing temperature on benthic marine life in Britain and Ireland. *Aquat Conserv: Mar Freshw Ecosyst* 14:333–362
- Hocking PJ, Meyer CP (1991) Carbon dioxide enrichment decreases critical nitrate and nitrogen concentrations in wheat. *J Plant Nutr* 14:571–584
- Horie T, Baker JT, Nakagawa H, Matsui T (2000) Crop ecosystem responses to climatic change: rice. In: Reddy KR, Hodges HF (eds) *Climate change and global crop productivity*. CAB International, Wallingford, pp 81–106
- IPCC (2007) *Climate change 2007: Synthesis report. Contribution of Working Groups to the Fourth Assessment Report of the Intergovernmental Panel on Climate Change*
- Jenner CF (1991a) Effects of exposure of wheat ears to high temperature on dry matter accumulation and carbohydrate metabolism in the grain of two cultivars. I. Immediate response. *Aust J Plant Physiol* 18:165–177
- Jenner CF (1991b) Effect of exposure of wheat ears to high temperature on dry matter accumulation and carbohydrate metabolism in the grain of two wheat cultivars. II. Carry over effects. *Aust J Plant Physiol* 18:179–190
- Kangasjärvi J, Talvinen J, Utriainen M, Karjalainen R (1994) Plant defense systems induced by ozone. *Plant Cell Environ* 17:783–794
- Kaplan A, Helman Y, Tchernov D, Reinhold L (2001) Acclimation of photosynthetic microorganisms to changing ambient CO<sub>2</sub> concentration. *Proc Natl Acad Sci USA* 98:4817–4818
- Karim Z, Hussain SG, Ahmed M (1996) Assessing impacts of climatic variations on food grain production in Bangladesh. *Water Air Soil Poll* 92:53–62
- Kee SC, Nobel PS (1985) Fatty acid composition of chlorenchyma membrane fractions from three desert succulents grown at moderate and high temperature. *Biochim Biophys Acta* 820:100–106
- Kickert RN, Krupa SV (1991) Modeling plant response to tropospheric ozone: A critical review. *Environ Poll* 70:271–383
- Kim HY, Lieferring M, Kobayashi K, Okada M, Miura S (2003) Seasonal changes in the effects of elevated CO<sub>2</sub> on rice at three levels of nitrogen supply: A free air CO<sub>2</sub> enrichment (FACE) experiment. *Global Change Biol* 9:826–837
- Krishnan P, Swain DK, Bhaskar BC, Nayak SK, Dash RN (2007) Impact of elevated CO<sub>2</sub> and temperature on rice yield and methods of adaptation as evaluated by crop simulation studies. *Agric Ecosys Environ* 122:233–242
- Krupa S, Kickert RN (1993) The effects of elevated ultraviolet (UV)-B radiation on agricultural production. Report submitted to the Formal Commission on Protecting the Earth's Atmosphere of the German Parliament, Bonn, Germany, p 432
- Krupa S, McGrath MT, Andersen CP, Booker FL, Burkey KO, Chappelka AH, Chevone BI, Pell EJ, Zilinskas BA (2000) Ambient ozone and plant health. *Plant Dis* 85:4–12
- Kunst L, Browse J, Somerville C (1989) Enhanced thermal tolerance in a mutant of *Arabidopsis* deficient in palmitic acid unsaturation. *Plant Physiol* 91:401–408
- Leakey ADB, Bernacchi CJ, Dohleman FG, Ort DR, Long SP (2004) Will photosynthesis of maize (*Zea mays*) in the US Corn Belt increase in future [CO<sub>2</sub>] rich atmosphere? An analysis of diurnal courses of CO<sub>2</sub> uptake under free-air concentration enrichment (FACE). *Global Change Biol* 10:951–962
- Lee PC, Bochner BR, Ames BN (1983) A heat shock stress and cell oxidation. *Proc Nat Acad Sci USA* 80:7496–7500
- Leegood RC, Sharkey TD, von Caemmerer S (eds) (2000) *Photosynthesis: physiology and metabolism, advances in photosynthesis and respiration*, vol. 9 (series editor, Govindjee). Springer, Dordrecht
- Mahan JR, Burke JJ, Orzech KA (1987) The 'Thermal Kinetic Window' as an indicator of optimum plant temperature. *Plant Physiol* 82:518–522
- Mall RK, Aggarwal PK (2002) Climate change and rice yields in diverse agro-environments of India: evaluation of impact assessment models. *Clim Change* 52:315–330
- Manning W, von Tiedemann A (1995) Climate change: potential effects of increased atmospheric carbon dioxide, ozone, and ultraviolet-B radiation on plant disease. *Environ Poll* 88:219–245
- Mishra RK, Singhal GS (1992) Function of photosynthetic apparatus of intact wheat leaves under high light and heat stress and its relationship with thylakoid lipids. *Plant Physiol* 98:1–6
- Molnár I, Gáspár L, Sárvári E, Dulai S, Hoffmann B, Molnár-Láng M, Galiba G (2004) Physiological and morphological responses to water stress in *Aegilops biuncialis* and *Triticum aestivum* genotypes with differing tolerance to drought. *Func Plant Biol* 31:1149–1159
- Morrison DJ, Mallett KI (1996) Silvicultural management of *Armillaria* root disease in western Canadian forests. *Can J Plant Pathol* 18:194–199
- Nagarajan S (2005) Can India produce enough wheat even by 2020? *Curr Sci* 89:1467–1471
- Nema KG, Joshi LM (1973) Spot-blotch disease of wheat in relation to host age, temperature and moisture. *Indian Phytopathol* 26:41–48
- Pell EJ, Schlagnhauser CD, Arteca RN (1997) Ozone-induced oxidative stress: mechanisms of action and reaction. *Physiol Plant* 100:264–273
- Peng SB, Huang JL, Sheehy JE, Laza RC, Visperas RM, Zhong X, Centeno GS, Khush GS, Cassman KG (2004) Rice yield decline with higher night temperature from global warming. *Proc Natl Acad Sci USA* 101:9971–9975



- Plessi M, Erich FE, Rennenber H, Habermeyer J, Heiser I (2007) Influence of elevated CO<sub>2</sub> and ozone concentrations on late blight resistance and growth of potato plants. *Environ Exp Bot* 60:447–457
- Polley HW, Johnson HB, Mayeux HS (1994) Increasing CO<sub>2</sub>: comparative responses of the C<sub>4</sub> grass *Schizachyrium* and grassland invader *Prosopis*. *Ecology* 75:976–988
- Poorter H (1993) Interspecific variation in the growth response of plants to an elevated ambient CO<sub>2</sub> concentration. *Vegetation* 104(105):77–97
- Raison JK (1986) Alterations in the physical properties and thermal response of membrane lipids: correlations with acclimation to chilly and high temperature. In: St. John JB, Berlin E, Jackson PC (eds) *Frontiers of membrane research in agriculture*. Rowman and Allanheld, Totoma, NJ, pp 383–401
- Rane J, Shoran J, Nagarajan S (2000) Heat stress environments and impact on wheat productivity in India: guestimate of losses. *Indian Wheat News* 6:5–6
- Rao MV, Koch JR, Davis KR (2000) Ozone: a tool for probing programmed cell death in plants. *Plant Mol Biol* 44:345–358
- Rikin A, Dillworth JW, Bergman DK (1993) Correlation between circadian rhythm of resistance to extremes of temperature and changes in fatty acid composition in cotton seedlings. *Plant Physiol* 101:31–36
- Runekles VC, Krupa SV (1994) The impact of UV-B radiation and ozone on terrestrial vegetation. *Environ Poll* 83:191–213
- Samarakoon A, Gifford RM (1996) Elevated CO<sub>2</sub> effects on water use and growth of maize in wet and drying soil. *Aust J Plant Physiol* 23:53–62
- Sandermann H (1996) Ozone and plant health. *Annu Rev Phytopathol* 34:347–366
- Sandermann H (2000) Ozone/biotic disease interactions: molecular biomarkers as a new experimental tool. *Environ Pollut* 108:327–332
- Sandermann H, Ernst D, Heller W, Langebartels C (1998) Ozone: an abiotic elicitor of plant defence reactions. *Trends Plant Sci* 3:47–50
- Seneweera S, Ghannoum O, Conroy JP (2001) Root and shoot factors contribute to the effect of drought on photosynthesis and growth of the C<sub>4</sub> grass, *Panicum coloratum* at elevated CO<sub>2</sub> partial pressures. *Aust J Plant Physiol* 28:23–32
- Senioniti E, Manetos Y, Gavales NA (1986) Co-operative effects of light and temperature on the activity of phosphoenolpyruvate carboxylase from *Amaranthus paniculatus*. *Plant Physiol* 82:518–522
- Sharma RC, Duveiller E (2004) Effect of *Helminthosporium* leaf blight on performance of timely and late-seeded wheat under optimal and stressed levels of soil fertility and moisture. *Field Crops Res* 89:205–218
- Sharma RC, Duveiller E (2006) Spot blotch continues to cause substantial grain yield reductions under resource limited farming conditions. *Phytopathol* 154:482–488
- Sharma RC, Duveiller E, Gyawali S, Shrestha SM, Chaudhary NK, Bhatta MR (2004) Resistance to *Helminthosporium* leaf blight and agronomic performance of spring wheat genotypes of diverse origins. *Euphytica* 139:33–44
- Sharma RC, Ortiz-Ferrara G, Crossa J, Bhatta MR, Sufian MA, Shoran J, Ortiz R (2007) Genetic improvement and stability of wheat grain yield assessed through regional trials in the Eastern Gangetic Plains of South Asia. *Proceedings of the International Symposium on Wheat Yield Potential: Challenges to International Wheat Breeding Ciudad Obregón, Sonora, Mexico, 19–24 March 2006*, CIMMYT, Mexico, DF
- Sharma YK, León J, Raskin I, Davis KR (1996) Ozone-induced responses in *Arabidopsis thaliana*: The role of salicylic acid in the accumulation of defense-related transcripts. *Proc Natl Acad Sci USA* 93:5099–5104
- Siddique AB, Hossain MH, Duveiller E, Sharma RC (2006) Progress in wheat resistance to spot blotch in Bangladesh. *Phytopathology* 154:16–22
- Singh B, Elmaayar M, Andre P, Bryant CR, Thouez JP (1998) Impacts of a GHG-induced climate change on crop yields: effects of acceleration in maturation, moisture stress and optimal temperature. *Clim Change* 38:51–86
- Sionit N, Hellmers H, Strain BR (1980) Growth and yield of wheat under CO<sub>2</sub> enrichment and water stress. *Crop Sci* 20:687–690
- Sombroek WG, Gommers R (1998) The climate change – agricultural conundrum. In: Bazzaz F, Sombroek W (eds) *Global climate change and agricultural production*. Wiley, New York, pp 1–14
- Somerville C, Browse J (1991) Plant lipids, metabolism and membranes. *Science* 252:80–87
- Stott PA, Tett SFB, Jones GS, Allen MR, Mitchell JFB, Jenkins G (2000) External control of 20th century temperature by natural and anthropogenic forcing. *Science* 290:2133–2137
- Tyree MT, Alexander JD (1993) Plant water relations and the effects of elevated CO<sub>2</sub>: a review and suggestions for future research. *Vegetation* 104(105):47–62
- Upadhyaya A, Davis TD, Larsen MH, Walsen RH, Sankhla M (1990) Uniconazole-induced thermo-tolerance in soybean seedling root tissue. *Physiol Plant* 79:78–84
- Upadhyaya A, Davis TD, Sankhla M (1991) Heat shock tolerance and anti-oxidant activity in moth bean seedlings treated with tetacyclis. *Plant Growth Regul* 10:215–222
- Upreti DC, Garg SC, Tiwari MK, Mitra AP (2000) Crop responses to elevated CO<sub>2</sub>: technology and research (Indian studies). *Global Environ Res* 3:155–167
- Upreti DC, Dwivedi N, Mohan R, Paswan G (2001) Effect of elevated CO<sub>2</sub> concentration on leaf structures of *Brassica juncea* under water stress. *Biol Plant* 44:149–152
- Upreti DC, Dwivedi N, Jain V, Mohan R (2002) Effect of elevated CO<sub>2</sub> on the stomatal parameters of rice cultivars. *Photosynthetica* 40:315–319

- Upreti DC, Dwivedi N, Jain V, Mohan R, Saxena DC, Jolly S, Paswan G (2003) Responses of rice varieties to elevated CO<sub>2</sub>. *Biol Plant* 46:35–39
- Upreti DC, Dwivedi N, Saxena DC, Raj A, Paswan G (2004) Impact of enhanced CO<sub>2</sub> concentration on crop growth. In: Proc. Workshop on Agriculture, Forestry and Natural Ecosystem, Bangalore, India, pp 19–22
- Upreti DC, Abrol YP, Reddy VR (2007) Crop responses to elevated CO<sub>2</sub>. In: Tandon P, Khatri S, Abrol YP (eds) Biodiversity and its significance. IK International, New Delhi, pp 289–331
- Volaire F (2003) Seedling survival under drought differs between an annual (*Hordeum vulgare*) and a perennial (*Dactylis glomerata*). *New Phytol* 160:501–510
- Vu JCV, Baker JT, Pennanen AH, Allen LH Jr, Bowes G, Boote KJ (1998) Elevated CO<sub>2</sub> and water deficit effects on photosynthesis, ribulose biphosphate carboxylase-oxygenase, and carbohydrate metabolism in rice. *Physiol Plant* 103:327–339
- Wardlaw IF (1974) Temperature control of translocation. In: Bielske RL, Ferguson AR, Cresswell MM (eds) Mechanism of regulation of plant growth. *Bull Royal Soc, Wellington*, pp 533–538
- Wattal PN (1965) Effect of temperature on the development of the wheat grain. *Indian J Plant Physiol* 8:145–159
- Whitmarsh J and Govindjee (1999) The photosynthetic process. In: Singhal GS, Renger G, Irrgang K-D, Sopory S, Govindjee (eds) Concepts in photobiology: photosynthesis and photomorphogenesis. Narosa Publishers/Kluwer, New Delhi/Dordrecht, pp 11–51
- Wong SC (1979) Elevated atmospheric partial pressure of CO<sub>2</sub> and plant growth. *Oecologia* 44:68–74
- Yalpani N, Enyedi AJ, Leon J, Raskin I (1994) UV light and ozone stimulate accumulation of salicylic acid, pathogenesis-related proteins and virus resistance in tobacco. *Planta* 193:372–376
- Young KJ, Long SP (2000) Crop ecosystem responses to climatic change: maize and sorghum. In: Reddy KR, Hodges HF (eds) Climate change and global crop productivity. CAB International, London, pp 107–131
- Ziska LH, Hogan KP, Smith AP, Drake BG (1991) Growth and photosynthetic response of nine tropical species with long term exposure to elevated carbon dioxide. *Oecologia* 86:383–389
- Ziska LH, Weerakoon W, Namuco OS, Pamplona R (1996) The influence of nitrogen on the elevated CO<sub>2</sub> response in field-grown rice. *Aust J Plant Physiol* 23:45–52
- Ziska LH, Sicher RC, Bunce JA (1999) The impact of elevated carbon dioxide on the growth and gas exchange of three C<sub>4</sub> species differing in CO<sub>2</sub> leak rates. *Physiol Plant* 105:74–80

# Subject Index

## A

ABA flux, 172  
Abiotic stress, 4–6, 8, 13, 35, 39, 44–46, 49, 54, 56, 76–85, 92, 97, 98, 103–117, 125, 132–134, 136–138, 140, 143, 146, 147, 165, 166, 177–195, 199–211, 218, 219, 230–236, 263–278, 288, 349–367, 372, 374, 379, 387–412, 418–438, 452–455, 457–466, 472, 479, 485–495  
Abscisic acid (ABA), 10, 33–57, 77, 78, 81–84, 86, 94, 95, 98, 105–107–114, 116, 117, 131, 136–138, 142, 147–150, 166–168–170–172, 180, 189, 200–210, 230–232, 234, 236, 249, 256, 285–297, 311, 356, 420, 423–425–427, 431, 432, 434, 435, 486, 488–490, 492, 493  
Abscisic acid metabolism, 35, 39, 43, 54–57, 287–288  
Aerenchyma, 11, 373–375  
Ammonium, 166–172, 311, 351, 429  
Apoptosis, 373–376, 378  
AREB, 45, 47, 180, 207–209, 211, 420  
Assimilation, 57, 166, 170, 171, 309–317, 320–323, 325–327–330, 332, 355, 505–507, 510, 514  
Association mapping, 462–463

## B

Brassinosteroid, 109–111, 126, 127, 129, 130  
Breeding strategy, 399, 405–406

## C

Calcineurin B-like, 76, 78, 81–82, 139, 147, 180, 248, 255, 422  
Calcium, 39, 48, 76–80, 83, 85, 138, 139, 141, 145, 148–150, 169, 171, 180, 187, 246, 284, 286, 287, 291, 293–296, 312, 375, 378, 379, 418, 421, 422, 486, 488, 490, 491, 494  
Calcium-dependent protein kinase, 418, 421  
Calcium sensing, 75–86  
Calcium signatures, 488  
Calmodulin, 41, 78–80, 139, 140, 187, 246, 256, 379, 421, 422, 494  
Carbon dioxide, 270, 284, 285, 290, 294–297, 328, 334, 488, 489, 504–511, 514–517

Charge balance, 166, 169–171  
Climate change, 12–13, 390, 418, 503–517  
Cold, 8, 10, 12, 19–22, 27, 35, 44–48, 54, 57, 77–82, 84–86, 92, 97, 104, 107, 110–112, 133, 135, 136, 138, 142, 149, 179, 180, 185–187, 189, 190, 192, 200–206, 210, 232–236, 285, 358, 361, 363, 366, 420, 421, 423, 425, 432, 434, 435, 437, 438, 486, 495  
Crops, 3–13, 35, 57, 125, 172, 178–180, 182, 188, 200, 203, 204, 211, 236, 253, 256, 264, 269–272, 285, 297, 328, 350, 365, 373, 379, 387–412, 418, 419, 431, 433, 438, 452, 453, 455, 457–459, 461, 472, 478, 481, 487, 504–516  
Cytokinin, 52, 56, 109–112, 114, 116, 287, 311, 375  
Cytoskeletal restructuring, 490, 491, 493–495

## D

Dehydration- responsive element-binding protein/ C-repeat binding factors (DREB/CBF ), 45, 47, 54, 78, 144, 180, 189, 192, 201–206, 210, 211, 232, 420, 425, 426, 438  
DELLA protein, 113–116  
Demethylation, 220, 223, 233, 236  
Development, 4–7, 10, 12, 35, 37, 38, 42–46, 48, 50, 56, 57, 76, 86, 92, 97, 99, 104, 105, 107, 110, 111, 113, 114, 116, 125, 130–132, 137, 138, 140, 145, 147, 148, 179, 183, 184, 187, 188, 192, 194, 195, 219, 223, 224, 231, 233, 235, 249, 256, 264, 266, 267, 273, 274, 284, 310, 319, 322, 333, 355, 366, 372, 373, 379, 389–391, 398, 406, 408–412, 418, 422, 423, 433, 435, 436, 438, 457, 459, 461, 463, 465, 466, 474, 487, 489, 490, 495, 506, 511–514  
DNA methylation, 219–221–224–226–228–230, 232–234–236, 479  
DNA microarray, 17, 18, 22, 23, 98  
Drought, 5, 7–10, 12, 35, 36, 39, 41, 44–47, 49, 50, 54, 56, 57, 80–82, 84, 85, 97, 105–107, 110, 112, 116, 125, 132, 134–136, 138, 142, 144, 148, 149, 165–172, 178–180, 185–189, 200–208, 210, 230–234, 236, 268, 270, 285, 287, 288, 297, 350, 358, 361, 366, 367, 389, 390, 409, 418, 420, 421, 424–429, 431–438, 453, 461–462, 486, 506, 508, 509  
Drought avoidance, 297, 437

- E**
- Environment, 16, 17, 47, 104, 166, 178, 183, 186, 187, 235, 236, 246–251, 273, 276, 297, 309–313, 316, 317, 322, 325–327, 329, 334, 356, 361, 390, 394–396, 404, 406, 409, 411, 418, 419, 452, 457, 461, 465, 472, 476, 477, 491, 510, 512–514
- Epigenetic effects, 219–236, 325, 479–481
- Evolution, 53, 219, 270, 318–320, 330, 351, 462, 466, 472, 474–477, 480, 481, 491, 516, 517
- G**
- Gene expression, 17–19, 21–24, 26, 27, 36, 38, 39, 44–45, 54, 56, 77, 79–83, 85, 92, 94, 96–98, 105, 135–137, 145, 149, 179–181, 183, 186–189, 192, 200–211, 219, 222, 224, 229, 231–233, 236, 267, 297, 314, 316, 326, 331–334, 355, 358, 423, 425, 427, 481, 487, 494, 495
- Genome, 17–19, 22–27, 35, 37, 41, 42, 44, 46, 53, 54, 79, 86, 97, 98, 104, 125, 132–134, 140, 141, 147, 182–187, 191–193, 195, 207, 210, 219–221, 223, 224, 229, 230, 233–236, 257, 295, 311, 313, 315, 318–321, 325, 329, 332–334, 419, 427, 436, 454–456, 462–465, 472, 474–477, 479–481, 487
- Germplasm exchange, 398, 399, 405, 411, 412
- Global warming, 418, 504, 514
- Glutathione, 43, 84, 93, 107, 186, 188, 263–278, 311, 316, 317, 320–322, 427–429, 475, 492
- Glutathionylation, 269, 273, 274, 277, 278, 491, 492
- Green house gases, 4, 12, 504, 505, 509
- H**
- Heat, 6–7, 10, 12, 24–26, 48, 49, 51, 77, 79, 81, 86, 94, 96, 104, 110–112, 138, 188, 200, 204–206, 210, 222, 232, 233, 330, 362–364, 409, 420, 421, 425, 433, 434, 478, 486, 504, 510, 512, 513, 516
- Histidine kinase, 16, 17, 19–21, 193, 420
- Histone modification, 219, 222, 224, 228, 229, 231, 236
- Hormone receptors, 486
- Hormone signaling, 97, 127, 130–131, 137–138, 148–149, 179
- Hydrogen peroxide, 106, 137, 264, 269, 420, 427, 473
- Hypersensitive response, 97, 104, 111, 124, 128, 129, 372, 486
- I**
- Inositol, 39, 78, 356–358–360, 367, 433
- Integrator, 113–116, 486, 490
- Interactome, 46, 192–195
- Ion channels, 35, 186, 251, 255, 290, 292, 489, 490, 493
- Ion homeostasis, 43, 179, 187–189, 245–259, 379, 421–423, 436, 438, 459, 460
- Ionic balance, 423, 435
- Ion transport, 24, 25, 80, 180, 248, 255, 309, 319, 419, 423, 436
- K**
- Kinase, 21, 49, 51, 82–86, 95, 125, 127–133, 140, 142, 208, 209, 221, 292, 320, 329, 420, 489
- M**
- Macronutrients, 166, 168, 308–335
- MAPK, 41, 86, 92, 97, 128, 132–137, 147, 149–150, 179, 272, 372, 378, 419–421, 492
- Metabolic profiling, 183, 186, 192
- Microarrays, 17–19, 21–26, 45, 46, 53, 97–99, 104–106, 110, 111, 115, 183, 185, 186, 189, 200, 203–206, 209, 210, 224, 225, 228, 320, 323, 420, 426, 494
- Mitochondria, 40, 76, 77, 94, 95, 139, 248, 265, 267, 273, 275, 277, 278, 321, 333, 362, 364, 375, 376, 429, 435, 475, 476
- Mutators, 471–481
- N**
- Nitrate nutrient deprivation, 167, 168, 171–172, 309–316
- O**
- Oryza sativa* L., 52, 182, 183, 266, 355, 356, 358, 389, 433
- Osmolyte, 44, 188, 288, 290, 291, 297, 349–367, 420, 429, 431, 432, 434
- Osmoprotectants, 361, 362, 419, 429
- Osmotic pressure, 112, 252, 289, 350, 489
- Osmotic regulation, 357, 420, 429–434
- Oxidative stress, 5, 22, 40, 41, 48, 77, 78, 81, 84, 94, 95, 97, 106, 107, 111, 132, 134, 136, 138, 186, 203, 233, 264, 269–271, 273, 274, 277, 278, 360, 375, 377, 378, 420, 422, 426, 428, 429, 431, 433, 479–481, 510



Ozone, 92, 107–109, 138, 265, 271–272, 317, 428, 486, 492, 504, 514–517

## P

Perception, 16, 18, 22–24, 26, 27, 35–37, 39, 56, 95–96, 99, 104, 109, 112, 125, 186, 210, 292, 296, 419, 421, 460, 487

Phosphatase, 43, 46, 49–52, 82, 86, 97, 129, 131, 141, 146, 148–150, 293, 328, 331, 332, 353, 356, 489, 494

Phosphate, 17, 23–24, 49, 125, 131, 145, 147, 171, 190, 192, 193, 204, 277, 278, 293–295, 314, 321, 327–331, 353, 356, 364, 378, 431, 433, 461, 486, 488, 491

Phosphorus, 11, 12, 309, 312, 330–334, 389, 453, 460–461

Photosynthesis, 6, 7, 10, 23, 93, 116, 188, 270, 273, 285, 296, 322, 330, 334, 355, 376, 433, 434, 479, 491, 504, 505, 508–511, 513–516

Productivity, 5–7, 10–12, 48, 99, 178, 200, 211, 269, 285, 316, 350, 389, 390, 392, 404, 411, 412, 418, 458, 466, 487, 503–517

Programmed cell death (PCD), 105, 107, 128, 138, 372–379, 432

Promoters, 17, 21, 27, 37, 42, 44, 53, 54, 57, 84, 85, 96, 98, 129, 130, 133, 180, 199–211, 222, 227, 229, 231–236, 269, 271, 285, 297, 314, 315, 323, 325, 331, 334, 335, 351, 353, 365, 366, 420–422, 425–427, 429, 431, 433, 435, 437, 438

Protein oxidation, 273, 276–278

Proteome, 46, 179, 189, 190, 192, 206

## Q

Quantitative trait loci (QTLs), 183, 257, 400, 453–458, 460–466

## R

Reactive oxygen species (ROS), 39–41, 91–99, 106, 107, 109, 114–116, 128, 132, 136–138, 140, 148, 179, 186, 188, 234, 264, 265, 267, 268, 271, 272, 275, 277, 293, 294, 323, 324, 327, 333, 372, 375–379, 419, 420, 427–429, 460, 486, 488, 490–495

Redox, 93–96, 107, 137, 150, 179, 264, 267, 268, 270–274, 276–278, 294, 314, 316, 322, 355, 377, 379, 420, 427, 428, 491

Redox homeostasis, 137, 179, 267, 274

Redox regulation, 95, 420, 427–429

Regulation, 18–27, 35, 38–40–42, 44–47, 49, 50, 54–57, 76, 77, 79–81, 83–84–86, 94–97–99, 105–107, 109, 111–113, 129, 131, 137, 144, 148, 149, 182, 183, 186–189, 194, 200, 201, 203, 204, 207, 209, 210, 217–236, 246, 247, 255, 256, 264–266, 273, 276, 277, 283–297, 313–314, 325, 326, 329–331, 349–367, 375, 376, 378, 379, 420, 422, 426–434, 438, 493

Response regulator, 17, 21, 23–25, 84, 193, 419

Rice, 4–13, 42, 45, 46, 54, 56, 77, 79, 81–84, 86, 94, 98, 108, 110, 112, 115, 125, 128, 130, 132, 133, 136, 137, 139–141, 146, 181–183, 186–190, 200, 203, 204, 207, 209–211, 231, 232, 235, 236, 246, 255, 266, 268, 269, 271, 311, 328, 355, 356, 358, 365, 366, 373, 374, 378, 387–412, 421–423, 425–431, 433–437, 453–455, 457–466, 505–508, 510, 516

Root to shoot signaling, 165–172

ROS crosstalk, 107, 276–278, 419, 420, 489, 490

## S

Salicylic acid, 34, 49, 105, 112, 130, 132, 135, 138, 204, 232, 234, 236, 378, 432, 486

Salinity, 5, 8, 11, 12, 39, 44–46, 57, 79–86, 125, 132, 134, 142, 166, 178, 180, 181, 183, 185–191, 199–201–205, 207, 208, 210, 219, 255, 258, 268, 269, 350, 354, 358, 361, 362, 364–367, 372, 387–412, 418, 420–422, 424–432, 435, 437, 453, 455, 458–460

Salinity screening, 402–403

Salt-stress, 22, 185, 355, 357, 358, 366, 397

Salt tolerance, 43, 45, 49, 80–83, 85, 133, 143, 144, 181, 188, 210, 246–247, 249, 251, 252, 254, 256, 258, 259, 268, 269, 358, 390–392, 396–398, 401, 404–406, 408–411, 421–423, 426, 427, 433–436, 438, 459, 460

Seed development, 7, 57, 231

Sensor, 16, 17, 19, 24, 25, 51, 78, 79, 83–85, 139, 180, 247, 248, 264, 334, 335, 419–421

Signaling, 10, 12, 34–57, 75–86, 91–99, 108, 110, 111, 113–115, 117, 123–150, 165–172, 179, 180, 186, 189–191–194, 204, 207, 209, 210, 264, 265, 269, 272–278, 285, 287, 288, 292–294–297, 315, 316, 323, 325, 326, 372, 376, 378, 379, 419–422, 424, 433, 459, 486–490, 494

Signaling cascade, 35–57, 76–86, 91–99, 125–150, 264, 265, 268, 269, 272–274, 277, 278  
 Signal perception, 18–25, 421, 460, 487  
 Signal transduction, 18, 19, 21, 22, 25, 26, 28, 44, 45, 94, 99, 123–150, 179–180, 186, 187, 190, 194, 200, 207, 269, 272, 274, 277, 278, 285, 290, 292–295, 297, 324, 372, 421–425  
 SiRNAs, 38, 229, 230, 233, 234  
 Stomata, 12, 37–39–41–43, 49, 56, 77, 78, 82–84–86, 94, 107, 112, 116, 137, 146, 148–150, 167–169–172, 209, 231, 270, 283–297, 316, 426, 437, 460, 487–494, 506–509  
 Stomatal response, 285–287, 296  
 Stress, 4, 16, 35, 76, 92, 104, 125, 166, 178, 200, 219, 246, 264, 284, 309, 350, 372, 389, 418, 452, 472, 486, 506  
 Stress adaptations, 35, 41, 56, 250, 252, 372  
 Stress memory, 234–236  
 Stress signaling, 39, 75–86, 91–99, 138, 147, 180, 419–424  
 Stress tolerance, 12, 35, 36, 42, 45, 46, 48, 53, 56, 78–80, 86, 108, 110–112, 114, 125, 137, 179–181, 183, 184, 186, 200, 202–207, 209–211, 219, 230, 232, 236, 263–278, 297, 351, 356, 361, 365–367, 387–412, 418–420, 422, 424–432, 435, 437, 438, 453–455, 457, 462, 463, 465, 466, 472  
 Sugar alcohols, 351, 433  
 Sulfur, 26, 264, 266, 274, 278, 309, 311, 316–327, 359, 377, 389, 486  
 System biology, 183, 487  
 Systemic acquired resistance (SAR), 135, 487  
 Systems biology, 487, 508

## T

Telescope model, 249, 250, 257, 258  
 Temperature, 4–9, 12, 20, 21, 25–27, 40, 46–48, 57, 112, 125, 132, 133, 166, 178, 180, 183,

190, 200, 201, 203, 204, 207, 219, 226, 227, 232–235, 247, 270, 271, 350, 354, 358, 362–364, 372, 389, 390, 402, 405, 408, 409, 412, 418, 424–426, 428, 429, 431, 434, 438, 458, 478, 504, 508–513, 516, 517  
 Transcription factor, 37, 45, 48, 50–52, 57, 81, 84, 85, 95, 97, 98, 108, 110, 114, 132, 133, 136, 137, 148, 183, 187, 189, 191, 192, 203–206, 209, 210, 231, 323, 325, 326, 329, 331, 422, 425–427  
 Transcriptome, 46, 77, 97, 105, 179, 184–187, 189, 192, 195, 235, 236  
 Transgenic plant, 44, 47, 94, 128, 129, 138, 149, 203–207, 209, 211, 224, 230–232, 254, 258, 268, 269, 271, 272, 354, 361, 365, 366, 419–438  
 Transpiration, 7, 9, 10, 56, 57, 167, 168, 171, 172, 230, 232, 236, 256, 288, 295, 408, 427, 434, 437, 504, 506, 508, 509, 517  
 Transport, 9, 24, 25, 40, 43, 57, 75, 76, 78, 80, 86, 94, 106, 113, 131, 133, 137, 138, 140, 143, 148, 166, 170–172, 180, 183, 186, 188, 229, 246, 248, 250–252–258, 264–266–267, 272, 278, 288, 290–291, 310–314–316–318–320, 322–324–326–328–329, 331, 333–334, 358–361, 363, 364, 375, 401, 419, 423, 436–438, 459, 460, 488, 492, 513  
 Transposons, 182, 187, 223, 228, 229, 233, 234, 236, 315, 461, 472, 475, 477

## V

Vesicular trafficking, 292, 487, 489–490, 493, 495

## W

Water efficiency, 9, 166, 283–297, 425, 507–508, 515  
 Water logging, 10–12, 178, 458  
 Water use efficiency, 9, 12, 166, 425, 504, 507–509, 515