

Allen J. Bard · György Inzelt · Fritz Scholz *Editors*

Electrochemical Dictionary

With more than
2.770
entries

$$E = E^{\ominus} + \frac{RT}{nF} \ln \frac{a_{\text{ox}}}{a_{\text{red}}}$$

 Springer

Electrochemical Dictionary

Allen J. Bard · György Inzelt · Fritz Scholz
(Eds.)

Electrochemical Dictionary

With 469 Figures and 18 Tables

Prof. Dr. Allen J. Bard
Hackerman/Welch Regents Chair
Director, Center of Electrochemistry
University of Texas at Austin
Chemistry and Biochemistry
1 University Station A5300
78712 Austin, TX, USA
ajbard@mail.utexas.edu

Prof. Dr. György Inzelt
Eötvös Loránd University
Department of Physical Chemistry
1117 Budapest, Pázmány Péter sétány 1/A, Hungary
inzeltgy@chem.elte.hu

Prof. Dr. Fritz Scholz
University Greifswald
Institute of Biochemistry
Felix-Hausdorff-Straße 4
17487 Greifswald, Germany
fscholz@uni-greifswald.de

ISBN 978-3-540-74597-6

e-ISBN 978-3-340-74598-3

DOI 10.1007/978-3-340-74598-3

Library of Congress Control Number: 2007941793

© 2008 Springer-Verlag Berlin Heidelberg

This work is subject to copyright. All rights are reserved, whether the whole or part of the material is concerned, specifically the rights of translation, reprinting, reuse of illustrations, recitation, broadcasting, reproduction on microfilm or in any other way, and storage in data banks. Duplication of this publication or parts thereof is permitted only under the provisions of the German Copyright Law of September 9, 1965, in its current version, and permission for use must always be obtained from Springer. Violations are liable to prosecution under the German Copyright Law.

The use of general descriptive names, registered names, trademarks, etc. in this publication does not imply, even in the absence of a specific statement, that such names are exempt from the relevant protective laws and regulations and therefore free for general use.

Coverdesign: WMX Design GmbH, Heidelberg

Production: le-tex publishing services oHG, Leipzig

Printed on acid-free paper

9 8 7 6 5 4 3 2 1

springer.com

Preface

Science needs language, not only for communication among people, but we all need language for thinking, for constructing models, for forming our ideas. Clear-cut terms that are accepted and understood by the scientific community are the basis of scientific language. The goal of this “Electrochemical Dictionary” is to provide a reference manual where the reader of electrochemical literature can quickly find short explanations of scientific terms. Fundamental definitions are very important, especially the recommendations of IUPAC, which were a primary source, where available. In many cases intensive discussion among the editors and expert authors resulted in the definitions that can be found in this book. It is our hope that the definitions of terms proposed herein will be accepted and used in the future by the scientific community. This dictionary includes not only the most frequently used terms, but also some that may be obsolete and even those whose use is discouraged. We intend the dictionary to be *encyclopedic in coverage of terms*, but relatively brief and clear in the individual entries. The goal to be encyclopedic in covering “all” terms is impossible to fulfill, partly because science is quickly developing with new terms arising almost daily, partly because it is practically impossible not to forget some. We hope that upcoming editions will close these gaps. The editors have decided to also include brief biographic entries of people who have contributed to the development of electrochemistry and have since passed away. Several of them were not electrochemists, and their contributions were mainly in the fields of physics, chemistry, and biology, but are also important in electrochemical research. Similarly, we include some entries about key techniques or materials that might be important in electrochemistry, although not directly in this field.

The authors and editors will be pleased if the “Electrochemical Dictionary” stands on the shelf of all those who read electrochemical papers and books, and if these readers will find it useful as a quick and reliable information source. Almost all entries are carefully referenced to enable the user to quickly locate the best primary sources. Of course, the authors and editors would appreciate any comments and suggestions for improvement.

We would like to thank Dr. Heike Kahlert and Dr. Birgit Meyer for their meticulous checking of literature references and the cross-referencing among the entries of the dictionary. We are equally thankful to Peter W. Enders (Springer, Heidelberg) for his continuous support and patience.

Allen J. Bard, György Inzelt, and Fritz Scholz
Austin, Budapest, and Greifswald
March 2008

List of Contributors

<p>Prof. Dr. Luisa M. Abrantes Departamento de Química e Bioquímica FCUL Campo Grande 1749-016 Lisboa <i>Portugal</i> luisa.abrantes@fc.ul.pt</p>	LMA	<p>Dr. Friedrich G. K. Baucke Kaiserstr. 36 (505) 55116 Mainz <i>Germany</i> f-baucke@t-online.de</p>	FB
<p>Nir Amir Bar-Ilan University Department of Chemistry 52900 Ramat-Gan <i>Israel</i> niramir75@yahoo.com</p>	NA	<p>Prof. Dr. Johan Bobacka Åbo Akademi University Process Chemistry Centre Laboratory of Analytical Chemistry Biskopsgatan 8 20500, Åbo-Turku <i>Finland</i> johan.bobacka@abo.fi</p>	JB
<p>Prof. Dr. Koichi Aoki Fukui University Department of Applied Physics 9-1, Bunkyo 3-chome Fukui-shi 910 <i>Japan</i> d930099@icpc00.icpc.fukui-u.ac.jp</p>	KA	<p>Prof. Dr. Alan M. Bond Monash University Department of Chemistry Clayton VIC 3168 <i>Australia</i> alan.bond@sci.monash.edu.au</p>	AMB
<p>Prof. Dr. Doron Aurbach Bar-Ilan University Department of Chemistry 52900 Ramat-Gan <i>Israel</i> aurbach@mail.biu.ac.il</p>	DA	<p>PD Dr. Andreas Bund Institut für Physikalische Chemie und Elektrochemie Technische Universität Dresden 01062 Dresden <i>Germany</i> andreas.bund@chemie.tu-dresden.de</p>	AB
<p>Dr. Maximiliano Bárcena Soto Departamento de Química CUCEI Universidad de Guadalajara 44420 Guadalajara, Jalisco <i>Mexiko</i> maxbar@gmx.net</p>	MBS	<p>Dr. Orit Chasid Bar-Ilan University Department of Chemistry 52900 Ramat-Gan <i>Israel</i> chasido@mail.biu.ac.il</p>	OC
<p>Prof. Dr. Allen J. Bard Hackerman/Welch Regents Chair Director, Center of Electrochemistry University of Texas at Austin Chemistry and Biochemistry 1 University Station A5300 Austin, TX 78712 <i>USA</i> ajbard@mail.utexas.edu</p>	AJB	<p>Dr. Jorge Correia Departamento de Química e Bioquímica Faculdade de Ciências Universidade de Lisboa Bloco C8, Campo Grande 1749-016 Lisboa <i>Portugal</i> jorge.correia@fc.ul.pt</p>	JC

Dr. Rudolf Dölling

Bank Elektronik — Intelligent Controls GmbH
Giessener Str. 60
35415 Pohlheim
Germany
info@bank-ic.de

Dr. habil. Mikołaj Donten

University of Warsaw
Department of Chemistry
Pasteura 1
02-093 Warsaw
Poland
donten@chem.uw.edu.pl

Dr. Lourdes E. Echegoyen

Clemson University
Chemistry Department
483 Hunter Laboratories
Clemson, SC 29634-0973
USA
lourdes@clemson.edu

Prof. Dr. Luis Echegoyen

Clemson University
Chemistry Department
483 Hunter Laboratories
Clemson, SC 29634-0973
USA
lourdes@clemson.edu

Hila Eshel

Bar-Ilan University
Department of Chemistry
52900 Ramat-Gan
Israel
hila.eshel@vishay.com

Prof. Dr. Stephen W. Feldberg

Brookhaven National Laboratory
Chemistry Department
P.O. Box 5000
Upton, NY 11973-5000
USA
feldberg@bnl.gov

RD **Dr. Adrian Fisher** AF

Centre for Research in Electrochemical
Science Technology
Department of Chemical Engineering
New Museums Site
Pembroke Street
Cambridge

MD
CB2 3RA
UK
acf42@cam.ac.uk**Prof. Dr. Stephen Fletcher** SF

Department of Chemistry
Loughborough University
Ashby Road

LEE
Loughborough
Leicestershire LE11 3TU
UK
stephen.fletcher@lboro.ac.uk**Dr. Fernando Garay** FG

INFIQC, Departamento de Fisico Quimica
Facultad de Ciencias Quimicas

LE
Universidad Nacional de Cordoba
Cordoba
Argentina
fsgaray@gmail.com**Prof. Dr. David Gavaghan** DG

Oxford University Computing Laboratory
Wolfson Building

HE
Parks Road
Oxford OX1 3QD
UK
david.gavaghan@comlab.ox.ac.uk**Dr. Kathryn Gillow** KG

Oxford University Computing Laboratory

SWF
Wolfson Building
Parks Road
Oxford OX1 3QD
UK
kathryn.gillow@comlab.ox.ac.uk**Prof. Dr. Peter Gründler** PG

Hallwachsstrasse 5
01069 Dresden
Germany
gruendler.dresden@freenet.de

- Dr. Yosef Gofer**
Bar-Ilan University
Department of Chemistry
52900 Ramat-Gan
Israel
goffery@mail.biu.ac.il
- Dr. Rubin Gulaboski**
Universität des Saarlandes
Institut für Biophysik
Medizinische Fakultät
66421 Homburg
Germany
rubingulaboski@excite.com
- Prof. Dr. Ulrich Guth**
Kurt-Schwabe-Institut für
Mess- und Sensortechnik e.V. Meinsberg
Kurt-Schwabe-Straße 4
04720 Ziegra-Knobelsdorf
Germany
guth@ksi-meinsberg.de
- Prof. Dr. Andrew Hamnett**
Principal's Office
University of Strathclyde
GLASGOW G1 1XQ
UK
andrew.hamnett@mis.strath.ac.uk
- Prof. Dr. Jürgen Heinze**
Universität Freiburg
Institut für Physikalische Chemie
Albertstr. 21 a
79104 Freiburg i. Br.
Germany
juergen.heinze@physchem.uni-freiburg.de
- Prof. Dr. Maria Hepel**
Chemistry Department
SUNY Potsdam
Potsdam, NY 13676
USA
hepelmr@potsteam.edu
- Dr. Michael Hermes**
Universität Greifswald
Institut für Biochemie
Felix-Hausdorff-Str. 4
17487 Greifswald
Germany
hermesm@uni-greifswald.de
- YG **Dr. Michael Heyrovský** MHey
Academy of Sciences of the Czech Republik
J. Heyrovský Institute of Physical Chemistry
Dolejšková 3
182 23 Praha
Czech Republic
michael.heyrovsky@jh-inst.cas.cz
- RG **Prof. Dr. Rudolf Holze** RH
TU Chemnitz
Institut für Chemie, AG Elektrochemie
09107 Chemnitz
Germany
Rudolf.holze@chemie.tu-chemnitz.de
- UG **Prof. Dr. György Horányi (†)** GH
Institute of Chemistry
Chemical Research Center
Hungarian Academy of Sciences
1525 Budapest
P.O. Box 17
Hungary
inzeltgy@chem.elte.hu
- AH **Prof. Dr. Ivo A. Hümmelgen** IH
Group of Organic Optoelectronic Devices
Departamento de Física
Universidade Federal do Paraná
Caixa Postal 19044
81531-990 Curitiba PR
Brazil
iah@fisica.ufpr.br
- JH **Prof. Dr. György Inzelt** GI
Department of Physical Chemistry
Eötvös Loránd University
1117 Budapest
Pázmány Péter sétány 1/A
Hungary
inzeltgy@chem.elte.hu
- MHep **Dr. Heike Kahlert** HK
Universität Greifswald
Institut für Biochemie
Felix-Hausdorff-Str. 4
17487 Greifswald
Germany
hkahlert@uni-greifswald.de
- MHer

- Prof. Dr. Takashi Kakiuchi** TK
Department of Energy and Hydrocarbon Chemistry
Graduate School of Engineering
Kyoto University
Kyoto, 615-8510
Japan
kakiuchi@scl.kyoto-u.ac.jp
- Prof. Dr. Alexander M. Kuznetsov** AMK
A. N. Frumkin Institute of Physical Chemistry
and Electrochemistry
Leninskii prospect 31, building 5
Moscow
Russia
theor@ns.elchem.ac.ru
- Prof. Dr. Evgeny Katz** EK
Milton Kerker Chair of Colloid Science
Department of Chemistry and Biomolecular Science
Clarkson University, Box 5810
8 Clarkson Avenue
Potsdam, NY 13699-5810
USA
ekatz@clarkson.edu
- Doc. Dr. Carita Kvarnström** CK
Åbo Akademi University
Process Chemistry Centre
Laboratory of Analytical Chemistry
Biskopsgatan 8
20500 Åbo-Turku
Finland
ckvarnst@abo.fi
- Dr. Vladislav V. Kharton** VK
Department of Ceramics and Glass Engineering
University of Aveiro
3810-193 Aveiro
Portugal
khorton@ua.pt
- Prof. Dr. Gyözö G. Láng** GGL
Eötvös Loránd University
Institute of Chemistry
Department of Physical Chemistry
1117 Budapest, Pázmány P. s. 1/A
Hungary
langgyg@chem.elte.hu
- Maxim Koltypin** MK
Bar-Ilan University
Department of Chemistry
52900 Ramat-Gan
Israel
maxim.k@dovermed.co.il
- Liraz Larosh** LL
Bar-Ilan University
Department of Chemistry
52900 Ramat-Gan
Israel
ch269@mail.biu.ac.il
- Dr. Šebojka Komorsky-Lovrić** ŠKL
Ruđer Bošković Institute
POB 1016
10001 Zagreb
Croatia
slovric@irb.hr
- Prof. Dr. Elena Levi** EL
Bar-Ilan University
Department of Chemistry
52900 Ramat-Gan
Israel
elenal@mail.biu.ac.il
- Prof. Dr. Paweł J. Kulesza** PK
University of Warsaw
Department of Chemistry
Pasteura 1
02-093 Warsaw
Poland
pkulesza@chem.uw.edu.pl
- Prof. Dr. Michael Levi** ML
Bar-Ilan University
Department of Chemistry
52900 Ramat-Gan
Israel
levimi@mail.biu.ac.il
- Prof. Dr. Włodzimierz Kutner** WK
Institute of Physical Chemistry
Polish Academy of Sciences
Kasprzaka 44/52
01-224 Warsaw
Poland
wkutner@ichf.edu.pl
- Naomi Levi** NL
Bar-Ilan University
Department of Chemistry
52900 Ramat-Gan
Israel
ch439@mail.biu.ac.il

- Dr. Adam Lewera**
University of Warsaw
Department of Chemistry
Pasteura 1
02-093 Warsaw
Poland
alewera@chem.uw.edu.pl
- PD Dr. Manuel M. Lohrengel**
Institut für Physikalische Chemie
Arbeitsgruppe Mikroelektrochemie
Heinrich-Heine-Universität Düsseldorf
Universitätsstr. 1, Geb. 26.32.02.34
40225 Düsseldorf
Germany
manuel.lohrengel@uni-duesseldorf.de
- Dr. Milivoj Lovrić**
Ruđer Bošković Institute
POB 1016
10001 Zagreb
Croatia
mlovric@irb.hr
- Prof. Dr. Jiří Ludvík**
J. Heyrovský Institute of Physical Chemistry
Dolejškova 3
182 23 Prague 8
Czech Republic
jiri.ludvik@jh-inst.cas.cz
- Dr. Frank Marken**
Department of Chemistry
University of Bath
Bath BA2 7AY
UK
f.marken@bath.ac.uk
- Dr. Elena Markevich**
Bar-Ilan University
Department of Chemistry
52900 Ramat-Gan
Israel
markeve@mail.biu.ac.il
- Dr. Boris Markovsky**
Bar-Ilan University
Department of Chemistry
52900 Ramat-Gan
Israel
markovb@mail.biu.ac.il
- AL **Dr. Sinéad Matthews** SM
Centre for Research in Electrochemical Science
and Technology (CREST)
Department of Chemical Engineering
University of Cambridge
New Museums Site
Pembroke Street
Cambridge
CB2 3RA
UK
acf42@cam.ac.uk
- MML **Dr. Birgit Meyer** BM
Schillerstr. 22B
15754 Senzig
Germany
bigimeyer@aol.com
- MLO **Prof. Dr. Alexander A. Milchev** AM
Rostislav Kaischew Institute of Physical Chemistry
Bulgarian Academy of Science
Acad. G. Bonchev Str., bl. 11
1113 Sofia
Bulgaria
amilchev@ipc.bas.bg
- JL **Prof. Dr. Valentin Mirčeski** VM
Sts. Cyril and Methodius University
Arhimedova 5
PO Box 162
91001 Skopje
Republic of Macedonia
valentinmirceski@netscape.net
- FM **Prof. Dr. Roger J. Mortimer** RJM
Department of Chemistry
Loughborough University
Loughborough
Leicestershire LE11 3TU
UK
r.j.mortimer@lboro.ac.uk
- EM **Prof. Dr. Royce W. Murray** RWM
The University of North Carolina at Chapel Hill
Department of Chemistry
Chapel Hill
NC 27599-3290
USA
rwm@email.unc.edu
- BMa

- Dr. Jan Myland**
Chemistry Department
Trent University
Peterborough, Ontario, K9J 7B8
Canada
jmyland@trentu.ca
- Prof. Dr. Keith B. Oldham**
Chemistry Department
Trent University
Peterborough, Ontario, K9J 7B8
Canada
koldham@trentu.ca
- Prof. Dr. Marcin Opałło**
Department of Electrode Processes (Department VII)
Institute of Physical Chemistry,
Polish Academy of Sciences
Kasprzaka 44/52
01-224 Warsaw
Poland
mopallo@ichf.edu.pl
- Prof. Dr. Toshiyuki Osakai**
Kobe University Nada
Department of Chemistry
Graduate School of Science
Kobe 657-8501
Japan
osakai@kobe-u.ac.jp
- Dr. Tamás Pajkossy**
Research Laboratory of Materials
and Environmental Chemistry
Chemical Research Center
Hungarian Academy of Sciences
Pusztaszeri út 59-67
1025 Budapest
Hungary
pajkossy@chemres.hu
- Prof. Dr. Ron Pethig**
University of Wales, Bangor
School of Informatics
Dean Street
Bangor
Gwynedd, LL57 1UT
UK
r.pethig@bangor.ac.uk
- JM **Prof. Dr. Oleg A. Petrii**
Moscow State University
Chemical Faculty
Department of Electrochemistry
Leninskie Gory, V-234 Moscow
GSP-3, 119899
Russia
petrii@elch.chem.msu.ru
- KBO **Elad Pollak**
Bar-Ilan University
Department of Chemistry
52900 Ramat-Gan
Israel
elad.pollak@gmail.com
- MO **Dr. Genady Ragoisha**
Physico-Chemical Research Institute
Belarusian State University
220050 Minsk
Belarus
ragoishag@bsu.by
- TO **Dr. Gregory Salitra**
Bar-Ilan University
Department of Chemistry
52900 Ramat-Gan
Israel
salitr@mail.biu.ac.il
- TP **Prof. Dr. Zdenek Samec**
J. Heyrovsky Institute of Physical Chemistry
Dolejškova 3
182 23 Prague 8
Czech Republic
zdenek.samec@jh-inst.cas.cz
- RP **Prof. Dr. Frieder Scheller**
Universität Potsdam
Mathematisch-Naturwissenschaftliche Fakultät
Institut für Biochemie und Biologie
Karl-Liebknecht-Str. 24–25, Haus 25
14476 Golm
Germany
fschell@rz.uni-potsdam.de
- Prof. Dr. Wolfgang Schmickler**
Department of Theoretical Chemistry
University of Ulm
89069 Ulm
Germany
wolfgang.schmickler@uni-ulm.de
- OP
EP
GR
GS
ZSam
FSche
WS

- Prof. Dr. Fritz Scholz**
 Universität Greifswald
 Institut für Biochemie
 Felix-Hausdorff-Str. 4
 17487 Greifswald
 Germany
 fscholz@uni-greifswald.de
- Dr. Uwe Schröder**
 Universität Greifswald
 Institut für Biochemie
 Felix-Hausdorff-Str. 4
 17487 Greifswald
 Germany
 uweschr@uni-greifswald.de
- Prof. Dr. Wolfgang Schuhmann**
 Ruhr-Universität Bochum
 Universitätsstr. 150, Gebäude NC 04/788
 44780 Bochum
 Germany
 wolfgang.schuhmann@ruhr-uni-bochum.de
- Dr. Abraham Soffer**
 Bar-Ilan University
 Department of Chemistry
 52900 Ramat-Gan
 Israel
 soffera@mail.biu.ac.il
- Prof. Dr. Zbigniew Stojek**
 University of Warsaw
 Department of Chemistry
 Pasteura 1
 02-093 Warsaw
 Poland
 stojek@chem.uw.edu.pl
- Prof. Dr. Hans-Henning Strehblow**
 Heinrich-Heine-Universität Düsseldorf
 Universitätsstr. 1
 40225 Düsseldorf
 Institut für Physikalische Chemie
 und Elektrochemie 2
 Germany
 henning@uni-duesseldorf.de
- Prof. Dennis E. Tallman**
 North Dakota State University
 Department of Chemistry
 Fargo, ND 58105-5516
 USA
 dennis.tallman@ndsu.edu
- FS **Yossi Talyossef** YT
 Bar-Ilan University
 Department of Chemistry
 52900 Ramat-Gan
 Israel
 taljosj@mail.biu.ac.il
- US **Prof. Dr. Xin-Cun Tang** XCT
 Central South University
 College of Chemistry & Chemical Engineering
 Changsha Hunan, 410083
 China
 tangxincun@163.com
- WSchu **Prof. Dr. Galina Tsirlina** GT
 Moscow State University
 Chemical Faculty
 Department of Electrochemistry
 Leninskie Gory, V-234 Moscow
 GSP-3, 119899
 Russia
 tsir@elch.chem.msu.ru
- AS **Prof. Constantinos G. Vayenas** CV
 Department of Chemical Engineering
 Caratheodory I, St.
 University of Patras
 26500, Patras
 Greece
 cat@chemeng.upatras.gr
- ZS **Prof. Dr. Alexander G. Volkov** AV
 Department of Chemistry
 Oakwood University
 7000 Adventist Blvd.
 Huntsville, AL 35896
 USA
 agvolkov@yahoo.com
- HHS **Prof. Dr. Mikhail A. Vorotyntsev** MAV
 Université de Bourgogne
 ICMUB-UMR 5260
 Centre National de la Recherche Scientifique
 Bâtiment Mirande
 9 avenue A. Sarary
 BP 47870
 21078 Dijon Cedex
 France
 mv@u-bourgogne.fr
- DT

Prof. Dr. Joseph Wang

Department of Chemical & Materials Engineering
Ira A. Fulton School of Engineering
Arizona State University
P. O. Box 876006
Tempe, AZ 85287-6006
USA
joseph.Wang@asu.edu

Prof. Dr. Ulla Wollenberger

Universität Potsdam
Mathematisch-Naturwissenschaftliche Fakultät
Institut für Biochemie und Biologie
Karl-Liebknecht-Str. 24–25, Haus 25
14476 Golm
Germany
uwollen@rz.uni-potsdam.de

Dr. B. Yosypchuk

Academy of Sciences of the Czech Republic
J. Heyrovský Institute of Physical Chemistry
Dolejšková 3
182 23 Praha
Czech Republic
bohdan.josypchuk@jh-inst.cas.cz

JW **Dr. Ella Zinigrad**

Bar-Ilan University
Department of Chemistry
52900 Ramat-Gan
Israel
zinigre@mail.biu.ac.il

EZ

Prof. Dr. Cynthia G. Zoski

Department of Chemistry & Biochemistry
P.O. Box 30001, MSC 3C
1175 North Horseshoe Drive
New Mexico State University
Las Cruces, New Mexico 88003-8001
USA
czoski@nmsu.edu

CGZ

Prof. Dr. Petr Zuman

Clarkson University
129 Science Center Clarkson University
PO Box 5810 Potsdam
NY 13699-5810
USA
zumanp@clarkson.edu

PZ

A

Absolute potential → *potential*, and subentry → *absolute potential*

Absorbed electrolyte battery → *sealed battery*

Abrasive stripping voltammetry — Technique where traces of solid particles are abrasively transferred onto the surface of an → *electrode*, followed by an electrochemical dissolution (anodic or cathodic dissolution) that is recorded as a current–voltage curve [i]. It allows qualitative and quantitative analysis of metals, alloys, minerals, etc. The technique is a variant of → *voltammetry of immobilized particles* [ii].

Refs.: [i] Scholz F, Nitschke L, Henrion G (1989) *Naturwiss* 76:71; [ii] Scholz F, Schröder U, Gulaboski R (2005) *Electrochemistry of immobilized particles and droplets*. Springer, Berlin

FS

AC → *alternating current*

AC (alternating current) techniques — Electrochemical experiments (usually → *potentiostatic* ones) where the applied constant or linearly changed potential is superimposed by an alternating (sinusoidal) potential signal of small magnitude. As a response to this perturbation, intensity and a phase shift of the resulting alternating current at a steady state is followed and analyzed as a function of potential and applied frequency (→ *AC polarography*, → *AC voltammetry*, measurements and interpretation of → *faradaic impedance* and → *electrochemical impedance spectroscopy*).

Ref.: [i] Bard AJ, Faulkner LR (2001) *Electrochemical methods*, 2nd edn. Wiley, New York, chap 10, pp 368

JL

ACP — Acronym for **alternating current polarography**. → *polarography*, and subentry → *AC polarography*.

AC polarography → *polarography*, and subentry → *AC polarography*.

AC voltammetry — Historically the analysis of the current response to a small amplitude sinusoidal voltage perturbation superimposed on a DC (ramp or constant) potential [i]. Recent applications invoke large amplitude perturbation (sinusoidal, square wave or arbitrary wave

form) [ii]. DC and AC current components including fundamentals and higher order harmonics can be measured as a function of potential and/or frequency often invoking Fourier transform techniques. See also → *AC polarography*, → *Fourier transform voltammetry*.

Refs.: [i] Smith DE (1966) *AC polarography and related techniques: Theory and practice*. In: Bard AJ (ed) *Electroanalytical chemistry*, vol. 1. Marcel Dekker, New York; [ii] Bond AM, Duffy NW, Guo S, Zhang J, Elton D (2005) *Anal Chem* 77:186A

AMB

Acceptor number (or acceptivity), AN — is an empirical quantity for characterizing the electrophilic properties (→ *Lewis acid–base theory*) of a solvent A that expresses the solvent ability to accepting an electron pair of a donor atom from a solute molecule. AN is defined as the limiting value of the NMR shift, δ , of the ^{31}P atom in triethylphosphine oxide, $\text{Et}_3\text{P}=\text{O}$, at infinite dilution in the solvent, relative to n-hexane, corrected for the diamagnetic susceptibility of the solvent, and normalized:

$$\text{Et}_3\text{P}=\text{O} \leftrightarrow \text{Et}_3\overset{\oplus}{\text{P}}-\overset{\ominus}{\text{O}} + \text{A} \rightleftharpoons \text{Et}_3\overset{\delta\oplus}{\text{P}}\cdots\overset{\delta\ominus}{\text{O}} - \text{A}$$

$$AN = \frac{\delta_{\text{corr}}(\text{A}) - \delta_{\text{corr}}(n\text{-C}_6\text{H}_{14})}{\delta_{\text{corr}}(\text{Et}_3\text{PO}-\text{SbCl}_5) - \delta_{\text{corr}}(n\text{-C}_6\text{H}_{14})} \times 100$$

$$= \Delta\delta_{\text{corr}} \times 2.348/\text{ppm}.$$

In a secondary measure, tributyl phosphate, Bu_3PO_4 , is used as the probe: $AN = 1.131\delta_{\text{corr}}^{31}\text{P}(\text{Bu}_3\text{PO}_4) + 0.8$. The coefficient arises from arbitrary assignment of the value of $AN = 100$ to the interaction of $\text{Et}_3\text{P}=\text{O}$ with antimony pentachloride (SbCl_5) dissolved in 1,2-dichloroethane. AN includes a nonspecific polarity effect and, therefore, it does not vanish for aprotic, and nonprotogenic, solvents, i.e., $AN < 10$ for apolar and $10 < AN < 20$ for dipolar aprotic solvents. However, AN values for protic solvents are much higher, i.e., $25 < AN < 130$. AN is linearly correlated, among others, to the polarity parameter $E_{\text{T}}(30)$ for 51 solvents, $AN = -59.9 + 1.850E_{\text{T}}(30)$ and to the → *donor number (DN)*, $AN = 12.73 \log \varepsilon - 0.056DN - 2.33$.

Refs.: [i] Mayer U, Gutmann V, Gerger W (1975) *Monatsh Chem* 106:1235; [ii] Schmid R (1983) *J Solution Chem* 12:135; [iii] Symons MCR, Pena-Nuñez AS (1985) *J Chem Soc Faraday Trans 1*, 81:2421; [iv] Marcus Y (1993) *Chem Soc Rev* 22:409

WK

Accumulation potential → *potential*, subentry → *accumulation potential*

Accumulation region — An accumulation region is any part of a → *semiconductor* device that has an increased

A

concentration of majority carriers due to the presence of an electric field, so that it becomes nearly metallic in its \rightarrow *conductivity*. The electric field may arise from an externally applied bias, the presence of a nearby interface composed of a differently doped semiconductor material (as in a *p-n* junction), or the presence of a nearby interface composed of a metal (as in a \rightarrow *Schottky barrier*). Because an accumulation region contains majority carriers (which are mobile) it tends to be very thin (<10 nm, say). This is in contrast to a \rightarrow *depletion region*, which typically contains minority carriers arising from immobile donors, and which therefore tends to be relatively thick (20–200 nm, say). Under external illumination, accumulation regions readily interact with photons, but any electron-hole pairs that are generated rapidly undergo recombination. Thus, no photocurrents are seen in the external circuit when a semiconductor material is under accumulation.

SF

Accumulator — (secondary or rechargeable \rightarrow *battery*)

A battery with electrodes which can be returned to their initial (charged) state by electrochemical means (electrically rechargeable) or by other means (e.g., by mechanical exchange of an electrode in case of the \rightarrow *metal-air battery*, \rightarrow *aluminum-air battery*, \rightarrow *zinc-air battery*). An accumulator operates as a \rightarrow *galvanic cell* in the discharge mode, as an \rightarrow *electrolyzer* in the charging mode. Consequently, assignment of the electrodes depends on the mode of operation: In the charging mode the negative electrode operates as a \rightarrow *cathode*, the positive electrode as the \rightarrow *anode*. In the discharging mode the negative electrode is the anode, the positive electrode is the cathode.

Lead-acid accumulator — (\rightarrow *Sinshedden* 1854, \rightarrow *Planté* 1859–60) A secondary \rightarrow *battery* containing a lead dioxide positive electrode, a metallic lead negative electrode and a sulfuric acid aqueous electrolyte solution. The electrode reactions are

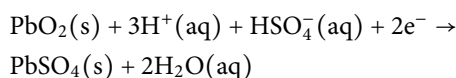

at the cathode; and

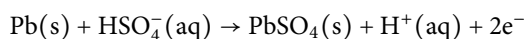

at the anode with the cell reaction

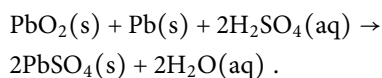

The negative electrode is usually prepared from lead metal powder (de Khotinski 1885) mixed with sulfuric acid pressed into a grid of a lead-antimony alloy serving both as mechanical backup and as current collector. The positive electrode is made from a mix of lead oxides and sulfuric acid again pressed into a grid of a lead-antimony alloy. The high porosity of both electrodes (suggested 1881 by Faure and Brush) results in a large electrochemically active surface area needed to keep the potential (cell voltage) losses small under load. During discharge sulfuric acid is consumed, resulting in a decrease of the electrolytic conductivity of the battery acid in the discharged state of the cell. Too high concentrations of the acid result in a decreased electrolytic conductivity; in addition the freezing point is increased. An optimum concentration is 35 wt%. The relationship between acid concentration (and consequently density) of the electrolyte solution and the state of charge has resulted in simple devices applied to measure the state of charge. Coulombic efficiency (\rightarrow *Coulometric efficiency*) is about 90%, overall energetic efficiency is about 75–80% because of the considerable difference between discharge and charge voltages. Lead-acid accumulators are used as the almost exclusive energy source in cars as a starter battery; they are used in \rightarrow *uninterruptible power supplies*. Deposition of metallic lead during charging would result in smooth surfaces without the large active surface area needed for practical operation; a rough deposit is obtained by adding expanders (complexing agents, e.g., lignin) to the electrolyte solution in very small concentrations. These additives (being present in the active masses of the accumulator with <1 wt%) also inhibit the negative consequences (mechanical destruction) of the density changes proceeding during the charge-discharge cycle (densities of Pb: $\rho = 11.4 \text{ g cm}^{-3}$, PbO₂: $\rho = 9.5 \text{ g cm}^{-3}$, PbSO₄: $\rho = 6.2 \text{ g cm}^{-3}$).

Refs.: [i] *Sinshedden J* (1854) *Ann Phys* 92:1; [ii] *Bode H* (1977) *Lead-acid batteries*. Wiley Interscience, New York; [iii] *Linden D, Reddy TB* (eds) (2002) *Handbook of batteries*. McGraw-Hill, New York

RH

Accuracy — The closeness of a measurement regarding its accepted or \rightarrow *true value*. Accuracy is also a concept to characterize a measuring instrument that gives responses very close to a true value.

Refs.: [i] *Harris D* (2002) *Quantitative chemical analysis*. WH Freeman, New York; [ii] *Currie LA, Svehla G* (1994) *Pure Appl Chem* 66:595

FG

Acetylene black \rightarrow *carbon*

Acheson® graphite — (electro graphite) Synthetic graphite prepared by the → *Acheson process*. Used in technology for reaction vessels, melting pots, heat-resistant black paint, → *electrodes*, brushes for electric generators and motors, pencils, colloiddally dispersed in oil (Oildag; dag = deflocculated Acheson graphite 1896) or water (Aquadag) as lubricant and corrosion protection, as moderator in nuclear reactors because of the neutron-decelerating capability (Wigner effect). See also → *graphite electrode*.

Refs.: [i] Magnusson M (ed) (1990) *Chambers biographical dictionary*. W&R Chambers, Ltd, Edinburgh; [ii] Crystal D (ed) (1998) *The Cambridge biographical encyclopedia*. Cambridge University Press, Cambridge

Acheson process — (Edward Goodrich Acheson: March 9, 1856, Washington, USA – June 6, 1931, New York City, USA, American chemist, inventor (abrasive Carborundum® 1891) and industrialist, coworker of → *Edison* 1881–1883, president of The Electrochemical Society 1908–1909). Coke and quartz (silica) are pressed and heated in an electric furnace at 800–1300 °C, subsequent graphitization proceeds at 2000–2200 °C. Formation of graphite under these conditions is attributed to growth of initially already present small graphite particles and/or decomposition of initially formed SiC. See also → *graphite electrode*.

Refs.: [i] Dittmeier R, Keim E, Kreysa G, Oberholz A (eds) (2005) *Winnacker-Küchler: Chemische Technik*, vol. 3. Wiley-VCH, Weinheim, pp 899; [ii] Kirk-Othmer (1992) *Encyclopedia of chemical technology*, vol. 4, 4th edn. Wiley, New York, pp 949; [iii] Crystal D (ed) (1998) *The Cambridge biographical encyclopedia*. Cambridge University Press, Cambridge

RH

by four chemical reactions: (a) giving a red color to blue vegetable dyes, (b) precipitating sulfur from ‘liver of sulfur’, (c) neutralizing bases, and (d) reacting with chalk to form a gas. Nicolas Lémery tried to give a more morphological definition (around 1690), according to which an acid has a spiky form and will prick the tongue, and bases consist of porous particles being slippery. Antoine Lavoisier (1777) created the word “oxygen” (from Greek *oxys* = sour and *genes* = born, i.e. acid maker), because at this time most of the known acids were obtained from non-metal oxides and water. Although it turned out that not all acids contain oxygen, the historical importance is given by the fact that it was the first systematic attempt to chemically characterize acids. In contrast to that, → *Davy* stated in 1810 that hydrogen is the key component of an acid, although many hydrogen-containing compounds were not acids. Justus von Liebig (1838) refuted the idea of Lavoisier and defined an acid as a special hydrogen-containing compound in which the hydrogen can be replaced by a metal. This definition of acids served for over 50 years.

Refs.: [i] Finston H, Rychtman AC (1982) *A new view of current acid–base theories*. Wiley, New York; [ii] Hand CW, Blewitt HL (1986) *Acid–base chemistry*. Macmillan, New York

HK

Arrhenius acid–base theory → *Arrhenius* developed the theory of the electrolytic dissociation (1883–1887). According to him, an acid is a substance which delivers hydrogen ions to the solution. A base is a substance which delivers hydroxide ions to the solution. Accordingly, the neutralization reaction of an acid with a base is the formation of water and a salt. It is a so-called symmetrical definition because both, acids and bases must fulfill a constitutional criterion (presence of hydrogen or hydroxide) and a functional criterion (to deliver hydrogen ions or hydroxide ions). The theory could explain all of the known acids at that time and most of the bases, however, it could not explain the alkaline properties of substances like ammonia and it did not include the role of the solvent. → *Sørensen* (1909) introduced the → *pH* concept.

Refs.: [i] Finston H, Rychtman AC (1982) *A new view of current acid–base theories*. Wiley, New York; [ii] Hand CW, Blewitt HL (1986) *Acid–base chemistry*. Macmillan, New York

HK

Acid–base equilibrium → *equilibrium*, and → *acid–base theories*

Acid–base theories

Early acid–base theories — The word acid is derived from the Latin word *acidus* (sour) and the word alkaline is derived from the Arabic *al-qily* meaning “calcinated ashes of plants”. Already in the Middle Age, the most important strong acids, e.g., sulfuric acid, nitric acid, and hydrochloric acid had been described by alchemists. Until 1650, Paracelsus and others had characterized acids by their special properties. The terms “acid” and “base” were used for the first time by Otto Tachenius in 1666. Around 1675, Robert Boyle had stated that acids have a high dissolution power and can be characterized

Brønsted acid–base theory — In 1923, → *Brønsted* and, independently of him, → *Lowry* published essentially the same theory of acids and bases which can be applied not only to water as a solvent but also to all other → *protic solvents*, as well as to → *proton transfer* reactions in gases. An acid is defined as a proton donor, i.e.,

A

a substance (molecule, anion or cation) which is capable of splitting off a hydrogen ion. A base is a proton acceptor, i.e., a substance (molecule, anion or cation) which is capable of taking up hydrogen ions. Usually, hydrogen ions are associated with solvent molecules, e.g., H_3O^+ , $\text{C}_2\text{H}_5\text{OH}_2^+$ etc., see also \rightarrow *Eigen complex*, and \rightarrow *Zundel complex*. During each protolytic reaction, an acid is converted into the corresponding base and a base into the corresponding acid:

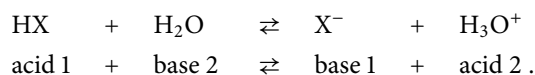

These acid–base pairs are called conjugate pairs. The extent of the reaction depends on the relative strength of the acid and the base. The model developed by Brønsted has the big advantage that \rightarrow *acid–base equilibria* can be described mathematically in a simple way, and it is used to estimate the pH of solutions. (According to the IUPAC recommendations the term ‘protolysis’ for proton transfer reactions should be discouraged).

Refs.: [i] Finston H, Rychtmann AC (1982) *A new view of current acid–base theories*. Wiley, New York; [ii] Hand CW, Blewitt HL (1986) *Acid–base chemistry*. Macmillan, New York; [iii] Tanabe K (1989) *New solid acids and bases*. Elsevier, Amsterdam

HK

Lewis acid–base theory — To describe reactions where no proton transfer occurs, \rightarrow Lewis has proposed a more general acid–base concept where an acid is a molecule or an ion with an incomplete outer electron sphere, i.e., an acceptor of electron pairs. A base is a molecule or an ion having a free electron pair, i.e., an electron pair donor. A neutralization reaction is characterized by the formation of a coordination or covalent bond. The following reactions illustrate the Lewis definition:

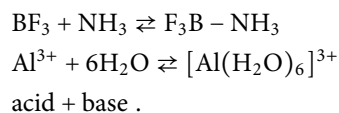

Proton-containing Brønsted acids are not Lewis acids because they cannot act as electron pair acceptors.

Refs.: [i] Finston H, Rychtmann AC (1982) *A new view of current acid–base theories*. Wiley, New York; [ii] Hand CW, Blewitt HL (1986) *Acid–base chemistry*. Macmillan, New York; [iii] Jensen WB (1980) *The Lewis acid–base concepts*. Wiley, New York; [iv] Tanabe K (1989) *New solid acids and bases*. Elsevier, Amsterdam

HK

HSAB concept — In 1963, Pearson published the concept of hard and soft acids and bases (HSAB). Based

on the theory developed by Lewis, he considered each chemical bond as a result of the reaction of a Lewis acid with a Lewis base:

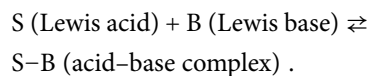

The concept describes the influence of parameters like electronegativity or ability to be polarized on the extent and on the stability of the chemical equilibrium. Pearson defines hard acids as Lewis acids with a low \rightarrow *polarizability* (small cations with high charge and molecules in which the binding partner induces a high positive charge at the central atom, e.g., Li^+ , Na^+ , Al^{3+}). A soft acid is a Lewis acid with a high polarizability (cations with small charge or high radii or atoms or molecules with valence electrons which can be released very easily, e.g., Cu^+ , Ag^+ , BH_3). Hard bases are Lewis bases with high \rightarrow *electronegativity* and low polarizability (e.g., H_2O , OH^- , F^- , NH_3). Soft bases are Lewis bases with low electronegativity and high polarizability (S^{2-} , SCN^- , CN^-). In general, reaction of hard acids with hard bases and soft acids with soft bases are preferred. The reaction of a hard acid with a hard base leads to a bond with more ionic character, whereas the reaction of a soft acid with a soft base leads to a more covalent bond. The combination of hard acid with a soft base, or vice versa, results in different bond characters of reaction partners and lower stability of the acid–base-complex.

Ref.: [i] Pearson RG (ed) (1973) *Hard and soft acids and bases*. Dowden, Hutchinson & Ross, Stroudsburg

HK

Base–antibase concept — This definition extends the acid–base concept to reactions in oxidic melts. The transfer of O^{2-} from a base (CO_3^{2-}) to an acid (sometimes called antibase) ($\text{S}_2\text{O}_7^{2-}$) can be considered as an acid–base reaction:

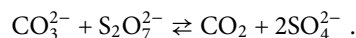

According to \rightarrow Bjerrum [i] an acid is defined as an acceptor of O^{2-} ions (antibase) and a base is defined as a donor of O^{2-} ions. A conjugate antibase/base pair differs by one O^{2-} . With that concept, the amphoteric behavior of oxides like Al_2O_3 is explainable and base–antibase reactions are important for transforming insoluble substances to water-soluble compounds by treatment in molten salts. Thus, aluminum oxide is transformable to a water-soluble product in molten basic Na_2CO_3 as well as in molten antibasic $\text{K}_2\text{S}_2\text{O}_7$: Al_2O_3 acts as acid (antibase)

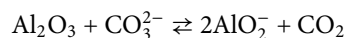

Al_2O_3 acts as base

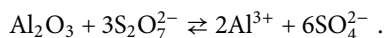

Ref.: [i] Bjerrum J (1947) *Acta Chem Scand* 1:528

HK

Usanovič acid–base theory — A general theory of acids and bases taking into consideration electron exchange processes (redox reactions) was proposed in 1939 by Usanovič. His definition is a symmetrical one and includes all concepts discussed above, i.e., an acid is defined as a substance which is able to liberate protons or other cations (cation donator) or to take up anions or electrons (anion acceptor, electron acceptor). A base is defined as a substance which is able to release anions or electrons (anion donator, electron donator) or to take up protons or other cations (cation acceptor). According to that theory, all chemical reactions (excluding reactions between radicals resulting in covalent bindings) can be considered as acid–base reactions.

Refs.: [i] Finston H, Rychtmán AC (1982) *A new view of current acid–base theories*. Wiley, New York; [ii] Hand CW, Blewitt HL (1986) *Acid–base chemistry*. Macmillan, New York

HK

Acidity constant — K_{an} (sometimes also called ‘acid dissociation constant’, or ‘acid-ionization constant’) is an equilibrium constant indicating the extent of the dissociation of the n^{th} hydrogen ion from a charged or uncharged acid [i]:

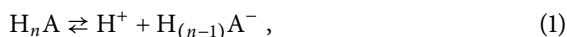

which can be taken as a partial acid–base reaction (half reaction). It is characterized by the thermodynamic constant [ii]

$$K_{an} = \frac{a_{\text{H}^+} a_{\text{H}_{(n-1)}\text{A}^-}}{a_{\text{H}_n\text{A}}} \quad (2)$$

(a is the concentration \rightarrow activity).

It is a weakness of the above definition that reaction (1) does not explicitly take into account the role of the solvent HS. The correct writing is:

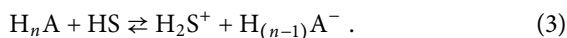

Hence, the acidity constant follows as:

$$K_{an} = \frac{a_{\text{H}_2\text{S}^+,c} a_{\text{H}_{(n-1)}\text{A}^-,c}}{a_{\text{H}_n\text{A},c} a_{\text{HS},mr}} \quad (4)$$

(Subscript c indicates concentration activities, and mr indicates molar ratio activities).

In very dilute solutions the molar fraction \rightarrow activity of the solvent ($a_{\text{HS},mr}$) approaches unity, and the \rightarrow activity coefficients of the acid–base species approach 1, the conventional stoichiometric concentration dissociation constant of an acid H_nA in a given solvent HS is:

$$K_{an} = \frac{[\text{H}_2\text{S}^+][\text{H}_{(n-1)}\text{A}^-]}{[\text{H}_n\text{A}]} \quad (5)$$

(Square brackets indicate concentrations in mol L^{-1}).

By analogy, one can define the basicity constant (K_{bn}) as the equilibrium constant indicating the extent of the uptake of the n^{th} proton by a base, e.g., for $n = 1$:

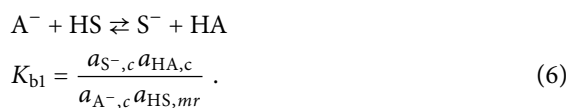

For each corresponding acid–base pair, e.g., HA and A^- , the acidity constant K_a and the basicity constant K_b are related to each other by the equation $K_{\text{auto}} = K_a K_b$, where K_{auto} is the \rightarrow autoprotolysis constant of the solvent.

Very strong acids dissociate practically completely in solution and consequently have large acidity constants; weak acids do not fully dissociate and generally have acidity constants far less than 1. Because these constants differ for each acid and vary over many orders of magnitude, the negative logarithm of the acidity constant is mostly given:

$$\text{p}K_a = -\log_{10} K_a.$$

Analogously to K_a , the magnitude of K_b indicates the relative strength of the base. Strong acids have weak bases as conjugated bases, and weak acids have strong bases as conjugated bases.

Acidity constants always compare the acidity of a proton donator with the basicity of the solvent. Therefore, only acidity constants relating to the same solvent can be compared [iii, iv]. The acidity constant strongly depends on the dielectric constant of the solvent and solvent–solute interaction parameters. About relations between the acidity constants of one acid in different solvents see reference [v].

Refs.: [i] McNaught AD, Wilkinson A (1997) *IUPAC Compendium of chemical terminology*, 2nd edn. Blackwell Scientific Publications, Oxford; [ii] Šůcha L, Kotrlý ST (1972) *Solution equilibria in analytical chemistry*. Van Nostrand Reinhold Company, London; [iii] Bordwell FG (1988) *Acc Chem Res* 21:456; [iv] Bordwell FG (1988) *Acc Chem Res* 21:463; [v] Šafařík L, Stránský Z (1986) *Titrimetric analysis in organic solvents*.

In: Svehla G (ed) *Wilson and Wilson's comprehensive analytical chemistry*, vol. 22. Elsevier, Amsterdam

HK

Action potential (nerves) — is the localized reversal and restoration of the electrical potential between the inside and outside of a nerve, muscle cell, or fiber, spatially propagated as an impulse, i.e., affect propagation. The alteration of the cell → *membrane potential* is generated by changes in the permeability of the membrane to specific ions, e.g., Na^+ , K^+ , and Cl^- , and maintained, with energy consumption, by a potassium-sodium pump (→ *ion transport through membranes and ion channels*). The action potential (nerve impulse) is a temporary depolarization, which is generated, when the usual potential between both sides of the cell membrane of ca. -75 mV is at first compensated, due to a temporary increase in sodium conductivity, and then reversed to approximately $+30$ to $+40$ mV. The action potential is triggered by an initial depolarization to a threshold potential, usually about 15 mV above the resting potential of the cell. An action potential involves a depolarization, a repolarization, and finally a hyperpolarization (so-called undershoot). In the axon fibers of nerves, the depolarization results from the ingress of Na^+ ions, while repolarization and hyperpolarization arise from an expulsion of K^+ ions. The depolarization phase is due to the opening of voltage-gated ion channels (Na^+ or Ca^{2+} channels or both). When a respective channel opens, positively charged ions enter the cell. Voltage-gated Na^+ channels automatically shut after about a millisecond. Calcium-mediated action potentials can have a much longer duration. The repolarization phase of an action potential is due to the opening of voltage-gated K^+ channels. Normally cells keep the concentration of K^+ ions high inside. When voltage-gated K^+ channels open, K^+ ions leave the cell, causing the membrane potential to return to a negative potential inside. Since K^+ channels open later and for longer than the Na^+ channels, the characteristic action potential curve results as shown in the Figure. Within a so-called absolute refractory period of ca. 1 ms, when Na^+ channels are closing and the K^+ channels are open, the membrane is unresponsive to a depolarizing current. This enables the nerves to carry rapid successions of impulses of up to 2500 s^{-1} . Furthermore, a relative refractory period serves as a recovery period after passage of an impulse, and stimuli therein must be of greater strength. It lasts ca. 2 ms from the end of the absolute refractory period.

The propagation of the action potential along the axons proceeds in two possible ways: For non-medullated

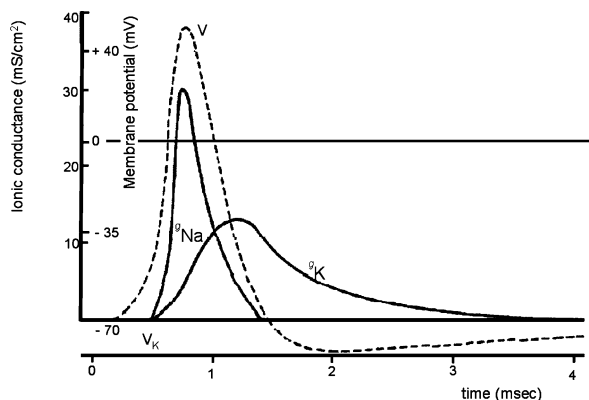

Action potential (nerves) — Figure

(unmyelinated) fibers, it results from the potential difference of the respective membrane part (at $+30$ V), compared to the neighboring compartment (at a resting potential of -75 V). The excitation in one part of the membrane will depolarize the adjacent part and bring it to the threshold. This restores the action potential here and advances the wave. That is, the compartments are successively depolarized with the ions diffusing from the positive into the negative cell, until the terminal synapses are reached. This mechanism is called continuous or electrotonic signal propagation, and the action potential proceeds as a wave at a slow transmission rate of 0.5 to 3 m s^{-1} (sufficient, e.g., for the alimentary tract). The second or saltatorial conduction mechanism holds for the thicker medullated neurofibrils, i.e., neurons with insulating sheaths of myelin surrounding their axons. Here, the signal is propagated much faster, directly from one Ranvier's node to the next. The fastest myelinated nerve fibers conduct potential pulses at a rate of up to 120 m s^{-1} , increasing with diameter. Rise in temperature up to 40 $^{\circ}\text{C}$ increases the transmission rate. The action potential conduction is an active mode propagation, so the peak amplitude of the depolarization does not decrease. It is mainly identical for plant and animal, but plants primarily use K^+ and Ca^{2+} currents, while animals use K^+ and Na^+ currents. The action potential initiation proceeds "all-or-none", i.e., on stimulation, the cell conducts only, if sufficient ligand-gated channels, above a certain threshold level, open, and the depolarization is sufficient to open adjacent voltage-gated channels.

Refs.: [i] Kandel ER, Schwartz JH, Jessell TM (2000) *Principles of neural sciences*, 4th edn. McGraw-Hill, New York; [ii] von Alvaro Macieira-Coelho A (2000) *Signaling through the cell matrix*. Springer, Berlin; [iii]

Freeman WJ (1975) *Mass action in the nervous system*. Academic Press, New York

MHer

Activation (of noble metal electrodes) — Noble metal electrodes never work well without appropriate pretreatment. Polycrystalline electrodes are polished with diamond or alumina particles of size from 10 μm to a fraction of 1 μm to obtain the mirror-like surface. The suspensions of polishing microparticles are available in aqueous and oil media. The medium employed determines the final hydrophobicity of the electrode. The mechanical treatment is often followed by electrochemical cleaning. There is no common electrochemical procedure and hundreds of papers on the electrochemical activation of → *gold* and → *platinum* (→ *electrode materials*) aimed at a particular problem have been published in the literature. Most often, → *cyclic* and → *square-wave voltammetry* and a sequence of potential → *pulses* are used. For platinum electrodes, it is important that during this prepolarization step the electrode is covered consecutively by a layer of platinum oxide and a layer of adsorbed hydrogen. In the work with single-crystal (→ *monocrystal*) electrodes the preliminary polishing of the surface can not be done.

Ref.: [i] Scholz F (ed) (2002) *Electroanalytical methods. Guide to experiments and applications*. Springer, Berlin

ZS

Activation energy — Symbol: E_a , SI unit: J mol⁻¹. Activation energy or (Arrhenius) activation energy (E_a) is to be used only for the empirical quantity defined as follows [i]:

$$E_a = RT^2 \frac{d \ln k}{dT},$$

where R is the → *gas constant*, T is the → *thermodynamic temperature*, and k is the rate coefficient.

Beside E_a other symbols E_A , E_{expt} , E_o are also used.

Other empirical equations with different “activation energies”, such as

$$k(T) = A' T^n \exp(-E'_a/RT),$$

are also being used.

The term activation energy is also used for an energy threshold appearing in electronic potential (the height of the electronic energy barrier). For this “activation energy” the symbol E_o and the term threshold energy is preferred, but E_a is also commonly used. Furthermore, E_o may or may not include a correction for zero point energies of reactants and the transition states.

It is thus recommended to specify in any given context exactly which activation energy is meant and to reserve (Arrhenius) activation energy only and exactly for the quantity defined above.

Activation energy was introduced in 1889 by → *Arrhenius* in a paper [ii] which dealt with the temperature dependence of the → *rate coefficient*. The → *Arrhenius expression (equation)* in that E_a appears is valid over a finite temperature range. E_a is usually determined by plotting $\ln k$ vs. $1/T$ on the basis of the following expression [iii, iv]

$$\ln k = \ln A - E_a/RT$$

which gives a straight line over a certain range of temperature. E_a is generally positive, however, in certain cases when a complex reaction mechanism prevails, the effective activation energy of the reaction derived by using the plot mentioned above, may also be negative. It happens, e.g., in the case of association reactions or reactions involving adsorption, when the apparent rate constant (k') is the product of the rate constant and the → *equilibrium constant* (K) and while k' increases, K decreases with T [iii, iv]. See also → *Gibbs energy of activation*.

Refs.: [i] Mills I, Cvitas T, Homann K, Kallay N, Kuchitsu K (eds) (1993) *IUPAC quantities, units and symbols in physical chemistry*. Blackwell Scientific Publ, Oxford, p 55; [ii] Arrhenius S (1889) *Z phys Chem* 4:226; [iii] Pilling MJ, Seakins PW (1995) *Reaction kinetics*. Oxford University Press, Oxford, pp 19–21; [iv] Atkins PW (1993) *Physical chemistry*. Oxford University Press, Oxford, pp 877–879, 889

GI

Activation overpotential — When the → *activation energy* of the → *charge transfer reaction* is high an → *overpotential* is needed to drive the reaction in the desirable direction with an appreciable rate. It is called activation overpotential (η_{ac}). The electric field (the → *inner electric potential*, ϕ) in the phase α determines the energy of the charged species: this can be expressed by the → *electrochemical potential* ($\bar{\mu}_i$).

$$\bar{\mu}_i^\alpha = \mu_i^\ominus + z_i F \phi^\alpha, \quad (1)$$

where μ_i is the → *chemical potential*, F is the → *Faraday constant*, and z_i is the → *charge number* of the species (ion or electron). For uncharged molecules ($z_i = 0$), $\bar{\mu}_i = \mu_i$. For a reaction $\sum \nu_i A_i = 0$, where A_i is for the reacting species and ν_i is the stoichiometric number, the → *Gibbs energy change* is

$$\Delta G = \sum \sum_i \nu_i \mu_i^\alpha. \quad (2)$$

A

The variation of ΔG as a function of the \rightarrow Galvani potential difference between α (metal) and β (solution) phase ($\Delta_\alpha^\beta \varphi$):

$$\Delta G = \Delta G^\ominus - zF\Delta_\alpha^\beta \varphi \quad (3)$$

when $z = +1$, and $z = 0$ for the other member of the redox couple. Alternatively, if both members of the redox couple are charged species, e.g., Fe^{3+} ($z_2 = +3$), Fe^{2+} ($z_1 = +2$)

$$z = n = z_2 - z_1 . \quad (4)$$

According to \rightarrow Polányi's rule the relationship between ΔG and the \rightarrow Gibbs energy of activation (ΔG^\ddagger) is

$$\Delta G^\ddagger = \alpha \Delta G , \quad (5)$$

where α is a proportionality factor (see also \rightarrow linear free energy relationships).

Since ΔG^\ominus is independent of the potential

$$\Delta G^\ddagger = \Delta G_0^\ddagger - \alpha z F \Delta \varphi . \quad (6)$$

If a \rightarrow reference electrode is used the Galvani potential difference can be replaced by $(E - E_c^{\ominus'})$, i.e., with the difference of the \rightarrow electrode potential related to a reference electrode and the \rightarrow formal potential, and then the change of the anodic and cathodic activation free energy (ΔG_a^\ddagger and ΔG_c^\ddagger) can be written as follows:

$$\Delta G_a^\ddagger = \Delta G_{0,a}^\ddagger - \alpha_a z F (E - E_c^{\ominus'}) \quad (7)$$

$$\Delta G_c^\ddagger = \Delta G_{0,c}^\ddagger + \alpha_c z F (E - E_c^{\ominus'}) , \quad (8)$$

where α_a is the anodic and α_c is the cathodic \rightarrow transfer coefficient. This explanation based on the potential energy surface representation was introduced by \rightarrow Polányi and \rightarrow Horiuti in 1935 [i].

If there is no other contributions to the \rightarrow overpotential ($\eta = E - E_{\text{eq}}$, where E_{eq} is the \rightarrow equilibrium potential), i.e., $\eta = \eta_{\text{ac}}$, taking into account the appropriate form of the \rightarrow Butler-Volmer equation for high enough anodic \rightarrow polarization ($\eta \gg RT/nF$)

$$\eta_{\text{ac}} = -\frac{RT}{\alpha_a nF} \ln j_0 + \frac{RT}{\alpha_a nF} \ln j = \frac{RT}{\alpha_a nF} \ln \frac{j}{j_0} \quad (9)$$

for cathodic polarization ($|\eta| \gg RT/nF$)

$$\eta_{\text{ac}} = \frac{RT}{\alpha_c nF} \ln j_0 - \frac{RT}{\alpha_c nF} \ln |j| = -\frac{RT}{\alpha_c nF} \ln \frac{|j|}{j_0} . \quad (10)$$

(See also \rightarrow Tafel equation.)

At low overpotentials ($\eta \ll RT/nF$)

$$\eta_{\text{ac}} \cong \frac{RT}{nF} \frac{j}{j_0} , \quad (11)$$

where j_0 the \rightarrow exchange current density, j is the \rightarrow current density, R is the \rightarrow gas constant, T is the temperature. The transfer coefficient is also called symmetry coefficient (factor) (\rightarrow charge transfer coefficient) [ii] since its actual value depends on the symmetry of the potential energy curve. If the harmonic oscillator approximation is valid for both the reactant and the product species $\alpha_a = \alpha_c = 0.5$, and for simple electron transfers $\alpha_a + \alpha_c = 1$. However, the harmonic oscillator approximation with identical force constants predicts identical parabolas, and a simple mathematical argument shows that in this case α depends on the potential [iii]. According to the \rightarrow Marcus theory α is potential dependent [iv]. The \rightarrow double layer or \rightarrow Frumkin effect may also influence the overpotential, i.e., the value of η_c determined by the measurement of the current-potential curve. The potential difference that can be applied to drive current through an electrolysis cell is also termed "activation potential" by engineers [v].

Refs.: [i] Horiuti J, Polányi M (1935) *Acta Physicochim URSS* 2:505 [in English (2003) *J Molecular Catalysis* A199:185]; [ii] Gileadi E (1993) *Electrode kinetics*. VCH, New York, pp 106–126; [iii] Pletcher D (1991) *A first course in electrode processes. The Electrochemical Consultancy, Hants*, pp 90–94; [iv] Bard AJ, Faulkner LR (2001) *Electrochemical methods*, Wiley, New York, pp 87–124; [v] Hamann CH, Hamnett A, Vielstich W (1998) *Electrochemistry*. Wiley-VCH, Weinheim, pp 306–307

GI

Activation polarization \rightarrow activation overpotential

Activation volume — As in case of homogeneous chemical reactions, also the rate of heterogeneous electron transfer reactions at electrode interfaces can depend on pressure. The activation volume ΔV_a involved in electrochemical reactions can be determined by studying the pressure dependence of the heterogeneous \rightarrow standard rate constant k_s : $\Delta V_a = -RT \left[\frac{\partial (\ln k_s)}{\partial P} \right]_T$ (R is the molar \rightarrow gas constant, T absolute temperature, and P the pressure inside the electrochemical cell). If ΔV_a is smaller than zero, i.e., when the volume of the activated complex is smaller than the volume of the reactant molecule, an increase of pressure will enhance the reaction rate and the opposite holds true when ΔV_a is larger than zero.

Refs.: [i] Swaddle TW, Tregloan PA (1999) *Coord Chem Rev* 187:255; [ii] Dolidze TD, Khoshtariya DE, Waldeck DH, Macyk J, van Eldik R (2003) *J Phys Chem B* 107:7172

FS

Activationless process — is an electrochemical reaction occurring with zero \rightarrow *activation energy*. This behavior is predicted for the region of high \rightarrow *overvoltage* which is rarely available in experiments because of \rightarrow *mass transport* limitations. The prediction of such type of processes follows from the theory of \rightarrow *Levich* and his school [i, ii]. For the diabatic \rightarrow *electron transfer* processes the total current density j can be estimated by integrating over the energy levels of a metal electrode ϵ :

$$j \approx \int_{-\infty}^{+\infty} \rho(\epsilon) n(\epsilon) \exp \left[-\frac{(\lambda - \epsilon - F\eta)^2}{4\lambda kT} \right] d\epsilon,$$

where $\rho(\epsilon)$ is the density of electronic states, $n(\epsilon)$ is the Fermi–Dirac distribution function (\rightarrow *Fermi–Dirac statistics*) (the \rightarrow *Fermi level* is reckoned from zero), η is the overvoltage, and λ is the total reorganization energy. The analysis of this equation allows defining the \rightarrow *transfer coefficient* α in the form:

$$\alpha \approx 1 - n(\epsilon^*),$$

where ϵ^* is the effective energy level which gives the largest contribution to the resulting current. If ϵ^* lies significantly lower than the Fermi level, the α values tend to zero, as well as the activation energy. This situation is far beyond the applicability limits of \rightarrow *Marcus theory* operating under the assumption of an electron transfer from the Fermi level exclusively, and predicting a linear decrease of α with overvoltage and the inverted region starting at a certain overvoltage. For electrochemical reactions, deviations from linearity start from $\alpha \sim 0.1$. Activationless reduction of \rightarrow *peroxodisulfate*, hexacyanoferrate, and some other anions at high overvoltages can be derived only from a thorough analysis of data, as it is severely screened by electrostatic effects [iii]. For this group of reactions it is possible to observe a slow electron transfer in the absence of mass transport limitations due to a strong electrostatic repulsion of the reactant from the negatively charged electrode. Activationless processes are important for a further development of the electron transfer theory and computational electrochemistry, as they are extremely sensitive to the electronic structure of metals.

Refs.: [i] Levich VG (1966) *Present state of the theory of oxidation and reduction in solution (bulk and electrode reactions)*. In: Delahay P (ed) *Adv electrochem electrochem eng*, vol. 4. Interscience, New York, pp 249–371; [ii] Kuznetsov AM, Ulstrup J (1999) *Electron transfer in chemistry and biology*. Wiley, Chichester; [iii] Nazmutdinov RR, Glukhov DV, Tširlina GA, Petrii OA, Botukhova GN (2003) *J Electroanal Chem* 552:261

GT, OP

Active carbon \rightarrow *carbon*

Active filter \rightarrow *analog filter*

Active mass — The portions of a \rightarrow *battery* or \rightarrow *accumulator* which are participating in electrode reactions, i.e., in the transformation of chemical into electrical \rightarrow *energy* or vice versa. In a \rightarrow *lead–acid battery* active masses are lead dioxide and lead, with the lead or lead alloy grid serving as \rightarrow *current collector* and mechanical holder and all other components are not active masses. For maximum \rightarrow *energy density* the fraction of active mass in the overall cell weight should be as large as possible.

RH

Activity — The absolute activity of a substance, λ , is defined as $\lambda = \exp(\mu/RT)$, where μ is the molar free energy. The relative activity a , is defined as $a = \exp[(\mu - \mu^\ominus)/RT]$, where μ^\ominus is the molar \rightarrow *free energy* of the material in some defined standard state for which the activity is taken as unity. Historically, the concept of activity arose out of an attempt, initially formulated by \rightarrow *Lewis*, to understand the behavior of mixtures. Ideal mixtures or solutions are those for which the \rightarrow *chemical potential* or molar free energy of any of the component species i can be written in the form $\mu_i = \mu_i^* + RT \ln x_i$, where x_i is the mole fraction of the i^{th} component, defined as $x_i = \frac{n_i}{\sum_j n_j}$, n_i is the number of moles of species i present in the mixture, and μ_i^* the molar free energy of the component in its pure form **at that temperature and pressure**. Very few mixtures are ideal over the full range of mole fractions: the derivation of the expression above depends on the enthalpy of mixing being zero (that is, the intermolecular forces are the same for all i – j pairs) and the molecular volumes are identical for all i, j species. However, from the expression for μ_i above, simple expressions may be derived for vapor pressure (Raoult’s and Henry’s Laws), the effect of temperature and pressure on vapor–solution and solution–solid equilibria, osmotic pressure, liquid–gas solubilities and solution phase equilibria. In order to retain the form of such expressions even when mixtures and solutions are not ideal, the chemical potential is often written in the form $\mu_i = \mu_i^* + RT \ln a_i \equiv \mu_i^* + RT \ln \gamma_i x_i$ where a_i is the **relative activity** as defined above and γ_i the \rightarrow *activity coefficient*. Considerable care needs to be taken now with the definition of μ_i^* as explained in the article on activity coefficients. It should be noted that the activities of all the components cannot be varied independently by virtue of the \rightarrow *Gibbs–Duhem equation*. For

A

a two-component mixture comprising a single phase, the Gibbs–Duhem equation takes the form $SdT - Vdp + n_a d\mu_a + n_b d\mu_b = 0$; if $x = x_a = 1 - x_b$ then it is easy to show that this reduces to $x \left(\frac{\partial \mu_a}{\partial x} \right)_{T,p} + (1-x) \left(\frac{\partial \mu_b}{\partial x} \right)_{T,p} = x_a \left(\frac{\partial \ln a_a}{\partial x_a} \right)_{T,p} + x_b \left(\frac{\partial \ln a_b}{\partial x_b} \right)_{T,p} = 0$.

Refs.: [i] Denbigh KG (1987) *Principles of chemical equilibrium*, 4th edn. Cambridge University Press, Cambridge; [ii] McNaught AD, Wilkinson A (1997) *IUPAC Compendium of chemical terminology*, 2nd edn. Blackwell Scientific Publications, Oxford; [iii] <http://www.iupac.org/publications/compendium/index.html>

AH

Activity of an electrolyte — The activity (a_{AB}) of an \rightarrow electrolyte AB dissociating in solution as:

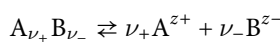

is usually expressed by the mean ionic activity that can be defined as follows:

$$a_{\pm} = \exp \left(\frac{\mu_{AB} - \mu_{AB}^{\ominus}}{\nu RT} \right)$$

or

$$a_{\pm} = \frac{m_{\pm} \gamma_{\pm}}{m^{\ominus}} = a_{\pm}^{\nu_+} a_{\pm}^{\nu_-}$$

and

$$a_{AB} = a_{\pm}^{\nu}$$

where

$$m_{\pm}^{\nu} = m_{+}^{\nu_+} + m_{-}^{\nu_-}$$

are the mean ionic molality and the ionic molalities, m^{\ominus} is the standard molality (1 mol kg⁻¹), $\nu = \nu_+ + \nu_-$ are the stoichiometric numbers, and μ_{AB} and μ_{AB}^{\ominus} are the \rightarrow chemical potential and the standard chemical potential of the electrolyte, respectively, and γ_{\pm} is the mean ionic \rightarrow activity coefficient. The individual activities of ions, a_+ , a_- cannot be determined experimentally.

Refs.: [i] Mills I, Cvitas T, Homann K, Kallay N, Kuchitsu K (eds) (1993) *IUPAC quantities, units and symbols in physical chemistry*. Blackwell Scientific Publ, Oxford, p 58; [ii] Parsons R (1974) *Pure Appl Chem* 37:503

GI

Activity coefficient — In general, for liquid mixtures or solutions, the \rightarrow chemical potential, or molar \rightarrow free energy, of each component i can be written in the form

$\mu_i = \mu_i^* + RT \ln a_i \equiv \mu_i^* + RT \ln \gamma_i x_i$ where a_i is termed the relative \rightarrow activity and γ_i the activity coefficient. Provided the pure form of each component is itself a liquid under the same conditions of temperature and pressure, then we expect that as $x_i \rightarrow 1$, $\gamma_i \rightarrow 1$ and μ_i^* can be interpreted as the molar free energy of the pure component i . However, if, in a liquid solution, component i in the pure form is a gas or solid, it is usual to distinguish between the solvent, for which the convention above still holds, and the component i for which we write $\mu = \mu_i^* + RT \ln \gamma_i x_i$ where now $\gamma_i \rightarrow 1$ when $x_i \rightarrow 0$. This reflects the fact that we are interested not in the solute in its pure form but rather in a dispersed form in the liquid. Intuitively, we expect the solution to behave in a quasi-ideal form as all solutes become very dilute, and we expect the solvent to behave under these circumstances also as close to ideal, which our convention has ensured. The main problem for the solute is the meaning of μ_i^* , it evidently corresponds to a hypothetical standard state in which each molecule or ion is surrounded by solvent and in which there is no change in intermolecular interactions as $a_i \rightarrow 1$. It is evident that such a state cannot be realized in practice: as the concentration of solute increases there will be changing interactions between solute species, and solvent-solute interactions will also change as the mean inter-solute molecular distance changes. The calculation of these changes on a molecular basis is one of the fundamental challenges of physical chemistry.

It is common not to use mole fraction as the measure of concentration in solutions, but rather to express the concentration of species in terms of molalities or molarities. The former is defined as the number of moles in a kg of solvent and the latter is defined as the number of moles per liter of solution (\rightarrow concentration). Since the molality is obviously temperature independent, it is the normal concentration measure used, and our convention for activity coefficient is now $\mu_s = \mu_s^* + RT \ln \gamma_s x_s$ for the solvent where the subscript 's' signifies solvent and $\gamma_s \rightarrow 1$ when $x_s \rightarrow 1$, and for the solute $\mu_i = \mu_i^* + RT \ln \gamma_i m_i$ where $\gamma_i \rightarrow 1$ as $m_i \rightarrow 0$. If there is more than one component, then the concentrations of all solutes must fall to zero simultaneously if the formula is to have any meaning, and it would be more correct to write $\gamma_i \rightarrow 1$ as $x_s \rightarrow 1$. (Different symbols were recommended by the IUPAC for the activity coefficients, i.e., f_i , γ_i and γ_i or $\gamma_{x,i}$, $\gamma_{m,i}$ and $\gamma_{c,i}$ when the concentration is expressed by mole fraction, molality and amount concentration (molarity), respectively, however, mostly γ_i is used.)

In the case of an \rightarrow electrolyte dissociating in solution as: $A_{\nu_+} B_{\nu_-} \rightleftharpoons \nu_+ A^{z_+} + \nu_- B^{z_-}$ where $\nu_+ z_+ = \nu_- z_-$ to ensure \rightarrow electroneutrality, and the total number of particles formed by each 'molecule' is $\nu = \nu_+ + \nu_-$, then the only activity that can be measured is that of the complete species, and the individual ions cannot be assigned meaningful chemical potentials. Under these circumstances, a mean activity coefficient is defined through the equation $\gamma_{\pm}^{\nu} = \gamma_+^{\nu_+} \gamma_-^{\nu_-}$. Since individual ionic chemical potentials are not measurable, it has become conventional to assign to the chemical potential of the hydrogen ion under standard conditions the value of zero, allowing relative chemical potentials for all other ions to be formulated.

The first accurate calculation of the activity coefficient based on energetic effects of inter-ionic interactions in solvents was carried out by \rightarrow Debye and \rightarrow Hückel in 1923; by assuming that all the deviations from ideality at low concentrations of electrolyte were due to inter-ionic interactions (\rightarrow Debye-Hückel theory) with this it is possible to show that

$$RT \ln \gamma_{\pm} = - \frac{N_A |z_A z_B| e^2 \kappa}{8\pi \epsilon \epsilon_0 (1 + \kappa a_0)},$$

where N_A is the Avogadro constant, ϵ is the \rightarrow permittivity of the solvent, a_0 the mean radius of the ion i , and κ is the \rightarrow Debye-Hückel parameter. Calculation of activity coefficients using this approach is normally accurate only below concentrations of 10^{-3} molar (10^{-2} M for symmetrical electrolytes). Above these concentrations, more sophisticated approaches in which ion-solvent interactions are also considered become essential, and a variety of methods have been suggested. Behavior at higher concentrations has also been modeled empirically: Guggenheim and Hitchcock suggested the equation

$$\ln \gamma_{\pm} = - \frac{A |z_+ z_-| \sqrt{I}}{1 + B a_0 \sqrt{I}} + bI,$$

where the concentration of electrolyte is expressed through the \rightarrow ionic strength, I , A is derived from the Debye-Hückel treatment, but B and b are now both treated as adjustable parameters.

A quite different approach was adopted by Robinson and Stokes, who emphasized that if the solute dissociated into ν ions, and a total of h molecules of water are required to solvate these ions, then the real concentration of the ions should be corrected to reflect only the bulk solvent. Robinson and Stokes derive, with these

ideas, the following expression for the activity coefficient:

$$\ln \gamma_{\pm} = - \frac{A |z_+ z_-| \sqrt{I}}{1 + B a_0 \sqrt{I}} - \frac{h}{\nu} \ln a_A - \ln [1 + 0.001 w_A (\nu - h) m],$$

where a_A is the activity of the solvent, w_A its molar mass, and m the molality of the solution. This equation has been extensively tested for electrolytes and provided h is treated as a parameter, fits remarkably well for a large range of electrolytes up to molalities in excess of 2. Unfortunately, the values of h so derived, whilst showing some sensible trends, also show some rather counter-intuitive effects, such as an increase from Cl^- to I^- . Furthermore, the values of h are not additive between cations and anions in solution, leading to significant doubts about the interpretation of the equation.

The measurement of activity coefficients can be done in one of two fundamental ways: either the activity of the solvent can be measured or that of the solute directly. In the first set of measurements comes that of the vapor pressure of the solvent, which is the most widely used. Related are measurements of freezing-point depression, boiling-point elevation, and osmotic pressure, the latter being very much more difficult in practice. Direct measurements of solute activity are usually carried out by measuring the potential of suitable cells with or without liquid junctions. Other techniques include solubility measurements, measurement of the solute vapor pressure, distribution of the solute between two immiscible liquids, and sedimentation in a centrifuge. These latter techniques have not come into general use, but are invaluable in specific favorable circumstances. Note that if the activity of the solvent is measured, the activity and activity coefficient of the solute must be calculated by the \rightarrow Gibbs-Duhem equation in its integrated form: $\ln \gamma_a = - \int_0^{x_a} \left(\frac{1-x'_a}{x'_a} \right) dx'_a$ where the subscript a refers to the solute and the subscript s to the solvent. Hence, by measuring γ_s at various concentrations, values of γ_a can be calculated.

Refs.: [i] Denbigh KG (1987) *Principles of chemical equilibrium*, 4th edn. Cambridge University Press, Cambridge; [ii] Robinson RA, Stokes RH (1970) *Electrolyte solutions*. Butterworths, London; [iii] Hamann CH, Hammett A and Vielstich W (1998) *Electrochemistry*. Wiley-VCH, Weinheim; [iv] McNaught AD, Wilkinson A (1997) *IUPAC Compendium of chemical terminology*, 2nd edn. Blackwell Scientific Publ, Oxford; [v] <http://www.iupac.org/publications/compendium/index.html>

A Actual capacity (of batteries) → *capacity***Adams, Ralph Norman**

(Courtesy of Z. Galus, Warsaw)

(Aug. 26, 1924, Atlantic City, New Jersey, USA – Nov. 28, 2002, Kansas City, MO, USA) Adams received a B.S. degree in Chemistry from Rutgers University in 1950 and his Ph.D. degree in Chemistry in 1953 for work supervised by → *Furman* at Princeton, where he remained until 1955 when he joined Kansas University. Until 1969 he worked mainly on electrochemical oxidation of organic compounds at solid electrodes. Since then his research was focused on applications of → *electroanalysis* in neuroscience, especially for detection of → *neurotransmitters*. An important breakthrough was the first publication of in-vivo sensing of neurotransmitters with implanted electrodes [i]. Among his many publications, the book on the electrochemistry at solid electrodes is of special significance [ii].

Refs.: [i] Kissinger PT, Hart JB, Adams RN (1973) *Brain Res* 55:209; [ii] Adams RN (1969) *Electrochemistry at solid electrodes (Monographs in Electroanalytical Chemistry and Electrochemistry)*. Marcel Dekker, New York

Adatoms → *underpotential deposition (upd)***ADC** → *analog-to-digital converter*

Adduct — A chemical product formed by direct combination of two separate molecular entities. Thus, the reaction between the chemical species nA and mB will produce the adduct A_nB_m if there is no loss of atoms within the moieties A and B. The stoichiometric coefficients n and m can be greater than 1. Intramolecular adducts can be formed when A and B are functional groups contained within the same molecular entity. If the adduct is formed by electron-pair donation from or to a π -orbital, then the resulting product is denom-

inated as a π -adduct [i]. See also → *quinhydrone electrode*.

Ref.: [i] Muller P (1994) *Pure Appl Chem* 66:1077

FG

Adhesion — (a) When two compact materials, be they solid or liquid, are in intimate contact, attractive forces may act between their surface atoms or molecules. These forces are typically → *van der Waals forces* and electrostatic forces. The work of adhesion $W_{A(B)B(A)}$ between the two phases (denoted A and B) is $W_{AB} = \gamma_A + \gamma_B - \gamma_{AB}$, where γ_A and γ_B are the → *interfacial tensions* of A and B when each is interfaced only with the vapor phase, and γ_{AB} is the interfacial tension of the interface between A and B. In a more rigorous treatment (at thermodynamic equilibrium) each phase is regarded as saturated with the other phase [i]. In the case of liquid phases the equation for the work of adhesion is referred to as the → *Dupré equation*. Adhesion forces between particles, or between particles and surfaces, dominate gravity for small particle sizes (μm and sub- μm range). In electrochemistry, increasing attention is being given to various phenomena related to the adhesion of vesicles [ii], particles [iii], droplets [iv], cells [v], etc. to electrode surfaces.

See also → *contact angle*, → *equilibrium form of crystals and droplets*, → *Young's equation*, → *Young's rule*.

(b) In galvanic coating, the term adhesion describes the quality of “sticking” of the coating onto its base material [vi]. To achieve the best adhesion the base material is often coated with a “flash” layer of intermediate metal, and impurities, grease, oxide layers, etc. are carefully removed before electrochemical plating (→ *electroplating*).

Refs.: [i] Adamson AW, Gast AP (1997) *Physical chemistry of surfaces*. Wiley, New York, pp 452; [ii] Hellberg D, Scholz F, Schubert F, Lovrić M, Omanović D, Agmo Hernández V, Thede R (2005) *J Phys Chem B* 109:14715; [iii] Scholz F, Hellberg D, Harnisch F, Hummel A, Hasse U (2004) *Electrochem Commun* 6:929; [iv] Ivošević N, Žutić V (1998) *Langmuir* 14:23; [v] Kovač S, Svetličić V, Žutić V (1999) *Colloids Surfaces* 149:481; [vi] Raub E, Müller K (1967) *Fundamentals of metal deposition*. Elsevier, Amsterdam, pp 150

FS

Adiabatic process (quantum mechanics) — In quantum mechanics a process is called adiabatic if electrons equilibrate with nuclei as they move. The concept of quantum adiabaticity was introduced by Paul Ehrenfest (1880–1933) as early as 1917, using pre-Heisenberg quantum mechanics [i]. The idea survived the advent of post-Heisenberg quantum mechanics, and was brought into its modern form by → *Born* [ii]. The existence of adiabatic processes is readily proved by considering

the Hamiltonian of any system. It can be shown that if a system starts out in an eigenstate H_1 , and changes very slowly, it will not cross into any other state, but will end up in a related eigenstate H_2 , which, though it has a different value than H_1 , is nevertheless connected to H_1 via a unique and continuous pathway. In brief, an adiabatic process is one that produces changes in eigenvalues, but does not produce changes in eigenstates. In the theory of electron transfer, adiabatic transformations are associated with slowly moving nuclei. These do not rapidly break up activated complexes, leaving plenty of time for electron transfer to occur. For this reason, adiabatic electron transfer processes occur with high probability, greatly simplifying the kinetic analysis. Indeed, in many cases, the rate of an adiabatic electron transfer process is just the rate of formation of the activated complex [iii, iv].

There is a tradition in electrochemistry, exemplified by the work of Marcus, that pictures electron transfer processes in terms of potential energy profiles of reactant and product sub-systems. In general, a multi-dimensional plot of the potential energy of a chemical system as a function of the coordinates of its constituent nuclei (assumed stationary) is called a potential energy surface. And the one-dimensional minimum energy route from reactants to products across such a surface is called the “potential energy profile”. For classical systems (i.e., for systems that do not participate in nuclear tunneling) potential energy profiles indicate the most probable route that a system will take while transforming from reactant to product. The concept of a potential energy profile was first suggested by René Marcelin (1885–1914) [v].

In the case of adiabatic electron transfer reactions, it is found that the potential energy profiles of the reactant and product sub-systems merge smoothly in the vicinity of the activated complex, due to the resonance stabilization of electrons in the activated complex. Resonance stabilization occurs because the electrons have sufficient time to explore all the available superposed states. The net result is the attainment of a steady, high, probability of electron transfer. By contrast, in the case of \rightarrow nonadiabatic (diabatic) electron transfer reactions, resonance stabilization of the activated complex does not occur to any great extent. The result is a transient, low, probability of electron transfer. Compared with the adiabatic case, the visualization of nonadiabatic electron transfer in terms of potential energy profiles is more complex, and may be achieved in several different ways. However, in the most widely used conceptualization, potential energy profiles of the reactant and product states

(considered independently of each other) are simply superimposed on one graph, such that they apparently cross in the vicinity of the activated complex. Because the probability of electron transfer is low at the crossing-point, the activated complex assembles and disassembles many times before the transition from the initial potential energy surface to the final potential energy surface actually takes place.

See \rightarrow nonadiabatic (diabatic) process, \rightarrow Marcus theory, \rightarrow Randles, and \rightarrow Gurney, \rightarrow adiabatic process (thermodynamics).

Refs.: [i] Ehrenfest P (1917) *Philos Mag* 33:500; [ii] Born M (1926) *Z Physik* 40:167; [iii] Marcus RA (1964) *Annu Rev Phys Chem* 15:155; [iv] Hush NS (1999) *J Electroanal Chem* 460:5; [v] Marcelin R (1913) *J Chim Phys* 10:1913

SF

Adiabatic process (thermodynamics) — In \rightarrow thermodynamics a process is called adiabatic (or isocaloric) if no exchange (gain or loss) of heat occurs between the system and its environment. The word was first used by W.J.M. Rankine in 1859 as a synonym for “non-crossing”, being derived from the classical Greek word *adiabatos*, meaning something like “(it is) forbidden to cross” [i].

See also \rightarrow adiabatic process (quantum mechanics).

Ref.: [i] Rankine WJM (1859) *A manual of applied mechanics*. Charles Griffin and Co, London

FS, SF

Adipodinitrile electrosynthesis \rightarrow Baizer–Monsanto process

Admittance — Symbol: Y , SI unit: S. Admittance $Y = I/U$ is a vector which defines the relationship between the sinusoidal \rightarrow alternating voltage $U = U_m \sin(\omega t)$ and the resulting \rightarrow current $I = I_m \sin(\omega t + \varphi)$, where U_m and I_m are the amplitude of the voltage and current, respectively, $\omega = 2\pi f$ is angular \rightarrow frequency (where f is in hertz) and φ is the phase difference between the current and the voltage [i]. The values U_m and ω are known, and I_m and φ are measurable quantities. The projections of Y on the coordinate axes depend on the phase difference: $Y' = |Y| \cos(\varphi)$ and $Y'' = |Y| \sin(\varphi)$, while the modulus is defined as $|Y| = I_m/U_m$. The projections Y' and Y'' determine the “in phase” and “out of phase” components of the response:

$$I = U_m [Y' \sin(\omega t) + Y'' \cos(\omega t)] . \quad (1)$$

The total admittance of a parallel connection is the vec-

torial sum of the individual admittances:

$$I = U_m \left[\sum_k (Y')_k \sin(\omega t) + \sum_k (Y'')_k \cos(\omega t) \right]. \quad (2)$$

Using the phasor concept, the admittance is a complex quantity: $I_m \exp [i(\omega t + \varphi)] / U_m \exp(i\omega t) = (I_m/U_m) \exp(i\varphi)$, where $i = \sqrt{-1}$. So, $Y = Y' + iY''$ [ii]. The real and imaginary parts of the admittance determine the responses as in Eqs. (1) and (2). The phase difference is defined as $\text{tg}(\varphi) = Y''/Y'$ and the modulus $|Y|$ as $\sqrt{(Y')^2 + (Y'')^2} = I_m/U_m$. For the \rightarrow resistance, the real and imaginary parts of the admittance are: $Y' = 1/R$ and $Y'' = 0$. For the \rightarrow capacitance, these parts are: $Y' = 0$ and $Y'' = \omega C$. For the self-inductance, $Y' = 0$ and $Y'' = -1/\omega L$. For the parallel connection of the resistance and the capacitance, $Y' = 1/R$ and $Y'' = \omega C$.

The real part Y' is called the \rightarrow conductance and the imaginary part Y'' is called the \rightarrow susceptance. The term admittance was coined by Oliver Heaviside in 1887.

The admittance is the inverse or reciprocal of the \rightarrow impedance (Z). The admittance and impedance are related by the extended equation:

$$\frac{Z'}{Y'} = \frac{Z''}{Y''} = (Z')^2 + (Z'')^2 = \frac{1}{(Y')^2 + (Y'')^2}.$$

Refs.: [i] Sluyters-Rehbach M, Sluyters JH (1970) *Sine wave methods in the study of electrode processes*. In: Bard AJ (ed) *Electroanalytical chemistry*, vol. 4. Marcel Dekker, New York, p 1; [ii] Southampton electrochemistry group (1985) *Instrumental methods in electrochemistry*. Ellis Horwood, Chichester, p 251

MLo

Adsorbate — is a substance that is adsorbed at an \rightarrow adsorbent. See also \rightarrow adsorption, \rightarrow adsorption isotherm, \rightarrow adsorption kinetics.

FS

Adsorbed hydrogen \rightarrow chemisorption of hydrogen

Adsorbed oxygen \rightarrow chemisorption of oxygen

Adsorbent — is the substance or material at which another substance, i.e., an \rightarrow adsorbate, is adsorbed. See also \rightarrow adsorption, \rightarrow adsorption isotherm, \rightarrow adsorption kinetics.

FS

Adsorption — Adsorption is the enrichment (positive adsorption, or briefly, adsorption) or depletion (negative

adsorption) of one or more components. In certain cases a decision as to whether the actual distribution of a component between the interfacial layer and the bulk phases should be looked upon as enrichment or depletion may depend on the choice of the reference system.

The terms adsorption and \rightarrow desorption may also be used to denote the **process** in which molecules accumulate at or are depleted from the interfacial layer [i].

Four limiting cases of adsorption at electrodes are distinguished: (a) purely electrostatic adsorption, (b) specific ionic adsorption, (c) adsorption of uncharged species (but including dipoles) and (d) \rightarrow chemisorption.

The strict thermodynamic analysis of an interfacial region (also called an \rightarrow interphase) [ii] is based on data available from the bulk phases (concentration variables) and the total amount of material involved in the whole system yielding relations expressing the relative surface excess of suitably chosen (charged or not charged) components of the system. In addition, the \rightarrow Gibbs equation for a polarizable interfacial region contains a factor related to the potential difference between one of the phases (metal) and a suitably chosen \rightarrow reference electrode immersed in the other phase (solution) and attached to a piece of the same metal that forms one of the phases.

In constructing statistical mechanical models for the interfacial structure, only long-range electrostatic effects are often considered and aside from the magnitude of the charges on the ions (and their radii) the differences in the chemical nature of the different ions are ignored. The well-known Gouy–Chapman (GC) model (\rightarrow double layer) is based on this approach. However, experimental observations show that in many cases, the behavior deviates significantly from that expected on the basis of GC theory. These deviations can be ascribed to short-range interactions between the ions and the surface of the metal. As these types of interactions are specific for both the metal and the ions, the adsorption resulting from these forces is called \rightarrow specific adsorption. In contrast to this, the adsorption of ions governed only by electrostatic effects and following GC theory is termed nonspecific adsorption. Adsorption of uncharged organic molecules without clear indication of chemical bond formation occurs by replacement of solvent (e.g. water) at the interface.

Chemisorption involves formation of bonds with the electrode surface with and/or without charge transfer across the interface.

Chemisorption of hydrogen and chemisorption of oxygen are examples of this process. The rupture of some

chemical bonds, and/or the decomposition of the original molecule are often occurring in the chemisorption of organic species, for instance, at platinum metal electrodes [iv] (see → *electrosorption*). Chemisorption of electrode reaction intermediates plays a key role in → *electrocatalysis*. About the interaction between adsorbed molecules see → *adsorption isotherms*, → *Frumkin isotherm*, → *Temkin isotherm*. See also → *adsorbate*, → *adsorbent*, → *induced adsorption*, and → *synergistic adsorption*.

Refs.: [i] (1972) *Definition, terminology and symbols in colloid and surface chemistry, Part I. Pure Appl Chem* 51:77; [ii] Horányi G (2002) *Specific adsorption. State of art: Present knowledge and understanding*. In: Bard AJ, Stratmann M, Gileadi M, Urbakh M (eds) *Thermodynamics and electrified interfaces. Encyclopedia of electrochemistry, vol. 1. Wiley-VCH, Weinheim*, pp 349–382; [iii] Calvo EJ (1986) *Fundamentals. The basics of electrode reactions*. In: Bamford CH, Compton RG (eds) *Comprehensive chemical kinetics, vol. 26. Elsevier, Amsterdam*, pp 1–78; [iv] Baltruschat H (1999) *Differential electrochemical mass spectrometry as a tool for interfacial studies*. In: Wieckowski A (ed) *Interfacial electrochemistry, theory, experiment, and applications. Marcel Dekker, New York*, pp 577–597

GI

Adsorption constant → *adsorption isotherms*

Adsorption isotherm → *adsorption* in systems of neutral molecules is frequently expressed in terms of an adsorption isotherm that gives the amount adsorbed (or surface excess) as a function of bulk activity of the same species at constant temperature [i]. In the case of electrified interfacial regions the electrical state of the region must also be kept constant for the determination of the relation between surface and bulk concentrations.

There are two ways to control the electrical state: determination at constant charge, σ^M , or at constant cell potential. From a thermodynamic point of view, isotherms with respect to relative surface excesses may be determined at constant charge or at any well-defined constant potential. However, the interpretation and physical meaning of the results may be significantly more difficult in the case when constant cell potential (→ *cell voltage*) is used.

In the case of adsorbed layers, by analogy with the two-dimensional pressure of spread films, a surface pressure (π) is introduced defined as the change of → *interfacial tension* (γ) caused by the addition of a given species to a base solution. At constant cell potential (E) this is

$$\pi = \gamma_{\text{base}} - \gamma,$$

where γ_{base} is the interfacial tension of the base solution.

The analogous quantity at constant charge is

$$\Phi = \xi_{\text{base}} - \xi,$$

where

$$\xi = \gamma + \sigma E.$$

In both cases, all other variables should be kept constant. However, in reality the interfacial concentration of other species may be changed by the introduction of one of the components.

Various isotherms have been proposed on the basis of different physical models. Three approaches can be distinguished:

- The solution phase is considered as a continuum and the behavior of the adsorbed species is similar to that of the adsorbate at the vapor-condensed phase interface.
- The adsorption process is a replacement reaction in which the adsorbing species replaces another species, normally the solvent.
- The interfacial region is regarded as a two-dimensional solution.

The simplest isotherm for the adsorption of a charged species is the → *Langmuir isotherm*

$$\frac{\theta_c}{1 - \theta_c} = Ka \exp(-FE/RT),$$

where θ_c is the fractional equilibrium surface coverage, a is the activity of the adsorbate in the solution, and E is the → *electrode potential*. The adsorption equilibrium constant, K , is related to the standard → *free energy of adsorption* through

$$\Delta G_{\text{ads}}^\ominus = -RT \ln K.$$

The exponential term in the above equation reflects the effect of the electrode potential on the free energy of adsorption of a charged species or adsorption of neutral molecules with charge transfer at the interface.

The Langmuir isotherm assumes an homogeneous surface and negligible lateral interactions. However, adsorption interaction between molecules and surface heterogeneity plays an important role in many cases.

Non-ideality due to lateral interactions can be treated in two ways, by introducing surface activity coefficients in the adsorption isotherms or expressing the free energy of adsorption as a function of coverage, on the basis that the free energy of adsorption varies with coverage.

A

Most common non-ideal isotherms semi-quantitatively describe lateral interactions through an exponential term in the coverage.

$$Kc = \frac{r\theta_c}{(1-\theta_c)_r} [\exp(a'\theta_c)]$$

with $a = a'RT/2\Gamma_c$, the lateral interaction parameter and r the number of solvent molecules displaced by the adsorbate from the interface. Γ_c is the saturation coverage.

It appears from the above equation that the free energy of adsorption increases with an increase in coverage when a' is negative (lateral repulsions) and, conversely, decreases for positive a' (attractive interactions) [ii].

In the limit of $a \rightarrow 0$, the ideal Langmuir adsorption isotherm is obtained. See \rightarrow *Frumkin isotherm*, and for the role of surface heterogeneity \rightarrow *Temkin isotherm*.

Refs.: [i] Horányi G (2002) *Specific adsorption. State of art: Present knowledge and understanding*. In: Bard AJ, Stratmann M, Gileadi M, Urbakh M (eds) *Thermodynamics and electrified interfaces. Encyclopedia of electrochemistry*, vol. 1. Wiley-VCH Verlag, Weinheim, pp 349–382; [ii] Calvo EJ (1986) *Fundamentals. The basics of electrode reactions*. In: Bamford CH, Compton RG (eds) *Comprehensive chemical kinetics*, vol. 26. Elsevier, Amsterdam, pp 1–78

Adsorption kinetics — Two fundamental models are usually used for the description of the rate of \rightarrow *adsorption* (and \rightarrow *desorption*) processes.

Langmuir–Hinshelwood kinetics

adsorption: $\nu = k_a c(1 - \Theta)$,

desorption: $\nu = k_d \Theta$.

At equilibrium ($\nu_a = \nu_d$) and for Θ the \rightarrow *Langmuir isotherm* is obtained. For transients:

$$d\Theta/dt = \nu_a - \nu_d = k_a c - (k_a c + k_d) \Theta .$$

Roginskii–Zel'dovich kinetics — which takes into consideration that the adsorption energy of the adsorption process depends on the coverage

$\nu_a = k_a c(1 - \Theta) \exp(-r_a \Theta)$,

$\nu_d = k_d \Theta \exp(r_d \Theta)$.

At equilibrium

$$\Theta/(1 - \Theta) = bc \exp[-(r_a + r_d) \Theta] .$$

For electrified interfaces both processes (adsorption and desorption) are influenced by the electrical state of the interface even in the case of electrically neutral species.

Assuming \rightarrow *Langmuir conditions* (\rightarrow *adsorption isotherm*) the rate of \rightarrow *hydrogen adsorption*

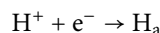

can be given by the equation

$$\nu_a = k_a c_{H^+} (1 - \Theta_H) \exp[-b_r (E - E_0^H)] ,$$

while the desorption rate



$$\nu_d = k_d \Theta_H \exp[b_a (E - E_0^H)] .$$

E_0^H is the standard (or formal) potential that involves the contribution originating from the standard Gibbs energy change of the adsorption. Usually it is selected in such a way that the rates of adsorption and desorption will be equal. In several cases the adsorption process is diffusion controlled. The rate of \rightarrow *electrosorption* processes occurring with some organic species can be limited by slow chemisorption. See also \rightarrow *Zel'dovich*.

Refs.: [i] Christensen PA, Hamnett A (1994) *Techniques and mechanisms in electrochemistry*. Blackie Academic & Professional, London; [ii] Koryta J, Dvořák J, Kavan L (1993) *Principles of electrochemistry*. Wiley, Chichester; [iii] Calvo EJ (1986) *Fundamentals. The basics of electrode reactions*. In: Bamford CH, Compton RG (eds) *Comprehensive chemical kinetics*, vol. 26. Elsevier, Amsterdam, pp 1–78; [iv] Oldham KB, Zoski CG (1986) *Mass transport to electrodes*. In: Bamford CH, Compton RG (eds) *Comprehensive chemical kinetics*, vol. 26. Elsevier, Amsterdam, pp 79–143

GI

Adsorptive accumulation — Organic substances which exhibit \rightarrow *surface activity* and \rightarrow *electroactivity* can be electrochemically analyzed by adsorptive accumulation on the surface of an electrode, e.g., \rightarrow *mercury electrode*, followed by the reduction, or oxidation of the adsorbate using \rightarrow *voltammetry* [i, ii]. Also, the adsorption of highly stable and inert \rightarrow *complexes* of metal ions with surface-active organic ligands is utilized for the determination of trace metals [iii]. In all these methods the maximum voltammetric response is linearly proportional to the surface concentration of the adsorbed analyte at the end of the accumulation period [iv]. In the majority of cases, the adsorption on mercury can be described by the \rightarrow *Frumkin isotherm*: $\beta c_{x=0} = \theta \exp(a\theta)/(1 - \theta)$, where β is the adsorption constant, $c_{x=0}$ is the concentration of the dissolved compound at the electrode surface, $\theta = \Gamma/\Gamma_{\max}$ is the surface coverage, Γ is the surface concentration of the adsorbed compound, Γ_{\max} is the maximum surface concentration and a is the Frumkin

coefficient. If $a < 0$ the lateral interactions between adsorbed molecules are attractive, and if $a > 0$ the interactions are repulsive. → *Langmuir isotherm* is obtained for $a = 0$. Both isotherms predict nonlinear relationship between Γ and the bulk concentration of the dissolved compound c^* . However, if $\theta \rightarrow 0$, the surface saturation can be neglected and a linear isotherm is obtained: $\beta\Gamma_{\max}c_{x=0} = \Gamma$. Considering that there is a linear relationship between $c_{x=0}$ and c^* , which depends on the → *mass transfer*, under this condition the maximum voltammetric response is a linear function of the bulk concentration of the analyte. So, for analytical purposes the surface coverage at the end of the adsorptive accumulation must not be higher than 10% [v]. Finally, electroinactive surfactants can be analyzed by measuring desorption peaks in → *alternating current voltammetry* (see → *tensammetry*) [vi].

Refs.: [i] Wang J (2000) *Analytical electrochemistry*. Wiley-VCH, New York; [ii] Kalvoda R (2000) *Electroanalysis* 12:1207; [iii] Bobrowski A, Zarebski J (2000) *Electroanalysis* 12:1177; [iv] Abollino O, Aceto M, Sarzanini C, Mentasti E (1999) *Electroanalysis* 11:870; [v] Novotný L, Havran L, Josypchuk B, Fojta M (2000) *Electroanalysis* 12:960; [vi] Čosović B (1990) In: Stumm W (ed) *Aquatic chemical kinetics*. Wiley, New York, p 291

ŠKL

Adsorptive stripping voltammetry — refers to a family of procedures involving a preconcentration by adsorption of the → *analyte* (usually organic compounds or metal → *complexes* with organic → *ligands*) onto the working electrode prior to its direct or indirect determination by means of an electroanalytical technique (see → *stripping voltammetry*) [i–iv]. In the voltammetric analysis scan, the adsorbed compound may be oxidized or reduced to produce a current signal that is proportional to the analyte concentration in solution.

See also → *anodic stripping voltammetry*, → *cathodic stripping voltammetry*.

Refs.: [i] Fogg AG, Wang J (1999) *Pure Appl Chem* 71:891; [ii] Vydra F, Stulik K, Julakova E (1976) *Electrochemical stripping analysis*. Halsted Press, New York; [iii] Wang J (1985) *Stripping analysis: Principles, instrumentation, and applications*. VCH, New York; [iv] Lovrić M (2002) *Stripping voltammetry*. In: Scholz F (ed) *Electroanalytical methods*. Springer, Berlin, pp 191–210

AMB

A-factor → *activation energy*

AFC → *alkaline fuel cells*

Affinity of a reaction, A — The decrease in → *Gibbs energy* on going from the reactants to the products of

$a \rightarrow$ *chemical reaction* ($-\Delta G$ in kJ mol^{-1}). The formerly used misleading term “driving force” is discouraged, since affinity is energy and not force.

Ref.: [i] Muller P (1994) *Pure Appl Chem* 66:1077

WK

AFM in situ electrochemistry — Atomic force microscopy (AFM) [i] can be applied in situ for studying electrochemical processes. Both the contact and the noncontact modes can be used. AFM has been successfully combined with → *scanning electrochemical microscopy* [ii]. AFM is extremely suitable to monitor the morphological changes occurring in electrochemical conversions of solid particles [iii, iv] and generally to probe electrode surfaces. It is an advantage that the electronic conductivity of the electrode surface is not important for the image generation. See also → *scanning probe microscopy*.

Refs.: [i] Burnham NA, Colton RJ (1993) *Force microscopy*. In: Bonnell DA (ed) *Scanning tunneling microscopy and spectroscopy*. VCH, New York, pp 191; [ii] Gardner CE, Macpherson JV (2002) *Anal Chem* 74:576A; [iii] Hasse U, Scholz F (2005) *Electrochem Commun* 7:173; [iv] Hasse U, Wagner K, Scholz F (2004) *J Solid State Electrochem* 8:842

FS

Air electrode — A → *gas diffusion electrode* operating at ambient air. In all reported applications → *oxygen reduction* proceeds at the air electrode, which is employed in → *fuel cells*, → *metal-air batteries*, → *electrolyzers* and → *sensors*. (See also → *porous electrodes*)

Ref.: [i] Kinoshita K (1992) *Electrochemical oxygen technology*. Wiley Interscience, New York

RH

AKZO-Billiton reactor — Improved type of → *fluidized-bed electrode reactor* used for extraction and reclamation of metals. The geometry resembling a shell-and-tube heat exchanger provides multiple feeder electrodes inside tubes filled with particles, the tubes themselves being of ceramic material acting as diaphragm. The improved internal design enhances flow, uniform fluidization, and prevents particle agglomeration. The numerous feeder electrodes facilitate a uniform potential distribution.

Ref.: [i] Pletcher D, Walsh FC (1993) *Industrial electrochemistry*. Blackie Academic & Professional, London

RH

Alcoa electrolyzer → *Alcoa process*

Alcoa process/Alcoa electrolyzer — This is a process to manufacture metallic aluminum by electrolysis of

A

molten aluminum chloride, made by chlorinating alumina. The \rightarrow *electrowinning* of aluminum from the electrolysis of AlCl_3 dissolved in a mixture of alkali and/or alkaline earth chlorides was attempted as early as 1854. The **Alcoa** electrolysis process was developed on an industrial scale in the 1970s by the **Aluminum Company of America**, (Pittsburgh, USA), and it was in commercial operation from 1976 to 1985 in Palestine (TX, USA).

The Alcoa electrolyzer is a bipolar cell (cf. \rightarrow *capillary gap cell*) (see Fig.). The feed consists of 3 to 10% (wt) of purified AlCl_3 along with the required amounts of alkali and alkaline earth chlorides. The electrolysis is performed under inert conditions in a sealed cell, which consists of 20 to 30 bipolar carbon electrodes stacked vertically at an interpolar distance of 1 cm. Each bipolar electrode behaves as a cathode on its top surface and as an anode on its bottom surface. Operating parameters are: $700 \pm 30^\circ\text{C}$, \rightarrow *current density* of $0.8\text{--}2.3\text{ A cm}^{-2}$, and a single-cell voltage of 2.7 V. Two typical compositions of the electrolyte (in wt%) are: AlCl_3 (5), NaCl (53), LiCl (40), MgCl_2 (0.5), KCl (0.5), and CaCl_2 (1); and AlCl_3 (5 ± 2), NaCl (53), and LiCl (42 ± 2). The carefully controlled aluminum chloride concentration is a crucial point to ensure a smooth operation. It must be above a certain limit to prevent the discharge of alkali ions (possible intercalate compounds of graphite), whereas the upper limit is set by the high vapor pressure of AlCl_3 . The oxide content of the electrolyte must be as low as possible to prevent significant anode consumption and the formation of insoluble oxy-chloride sludge. An operating life of nearly 3 years is claimed for the electrodes when the oxide content of the electrolyte remains

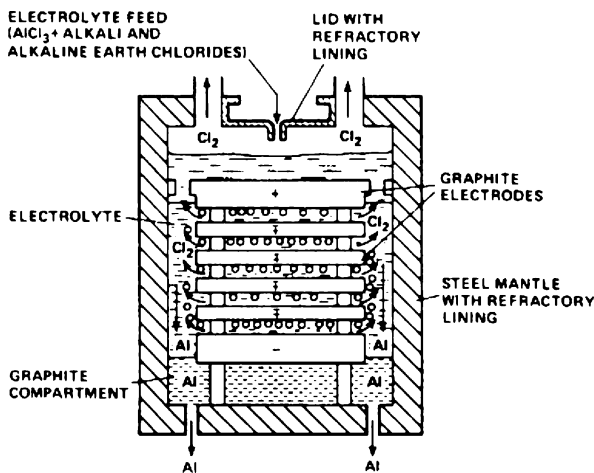

Alcoa process/Alcoa electrolyzer — Figure

below 0.03 wt%. The energy consumption of the cell is ca. $9\text{ kWh kg}^{-1}\text{ Al}$. The chlorine generated at the anode sweeps the aluminum away from the cathodes and enhances the coalescence of Al droplets. The pumping effect of the chlorine bubbles maintains a continuous electrolytic flow across the cell, thus preventing the formation of Al pools on the electrodes. Chlorine collects at the top of the cell while molten aluminum drops down into a graphite compartment at the bottom of the cell. Liquid aluminum is passed through a filter to be separated from any excess electrolyte. The electrolyte is recycled to the cell; chlorine gas is also recycled by using it in the carbo-chlorination step. Because of corrosion problems on one hand and improvements in the efficiency of conventional electrolysis on the other, the described Alcoa process was abandoned in 1985. The Alcoa process consumes 30% less power than the \rightarrow *Hall-Héroult* process, mainly because of the higher electrical conductivity of the electrolyte and the small interpolar distance of Alcoa cells, and can be operated at a lower temperature; however, it has proved (more) difficult to control.

Refs.: [i] Grjotheim K, Krohn C, Malinovsky M, Matiaskovsky K, Thonstad J (1982) *Aluminum electrolysis – Fundamentals of the Hall-Héroult process*. CRC Press, Boca Raton; [ii] Rao DB (1979) NASA SP-428:257–288; [iii] Palmear IJ (1993) In: Downs AJ (ed) *The chemistry of aluminium, gallium, indium, and thallium*. Kluwer Academic, London

MHer

Aliasing — An effect observed when the sampling rate is not as high as requested by \rightarrow *Nyquist's theorem*. This latter states that the maximum frequency component must be greater than twice the signal to be acquired. The frequency of the aliased signal is the difference between the signal frequency and the sampling rate. For example, a 2 kHz sine wave sampled at 1.5 kHz would be reconstructed as a 500 Hz sine wave. This is the reason why the input to an \rightarrow *analog-to-digital converter* must be filtered with a low-pass \rightarrow *filter* to remove frequencies above half the sampling rate. In this case, the low-pass filter is called an anti-aliasing filter. It is essential for a practical \rightarrow *ADC* system since aliased data cannot be restored [i].

Ref.: [i] Horowitz P, Hill W (2001) *The Art of electronics*. Cambridge University Press, Cambridge

FG

Alkali chloride electrolysis — Chlorine with its co-product sodium hydroxide (also called caustic soda or simply caustic) has been produced on an industrial scale for more than a century by the electrolysis of a saturated solution of sodium chloride (brine). The process, which is often referred to as brine electrolysis or chlorine-

caustic production, covers 2/3 of the production volume of the total world chlorine capacity (ca. 43.4 million tons in 1998), and with 2400 billion kWh it is also the second largest consumer of electricity among electrolytic industries world-wide (see also \rightarrow *chlor-alkali production*). In all these processes, chlorine is produced at the \rightarrow *anode*, according to: $2\text{Cl}^- \rightarrow \text{Cl}_2 + 2\text{e}^-$. The anodes, initially made from graphite, are now throughout made from titanium with special coatings of electrocatalytic mixed oxides (so-called \rightarrow *dimensionally stable anodes* (DSA); see also \rightarrow *electrocatalysis*). The main three types of electrolysis are (a) the mercury cell process, (b) the diaphragm process, and (c) the membrane cell process:

(a) Mercury cell process

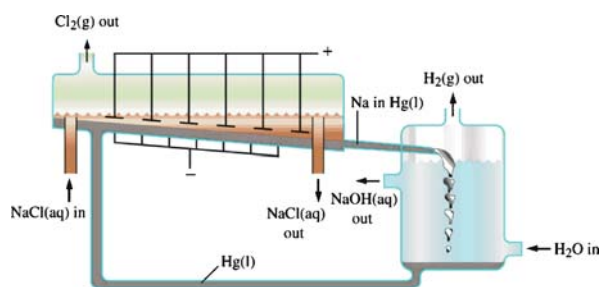

Alkali chloride electrolysis — Figure 1

In the mercury cell process, sodium forms an \rightarrow *amalgam* with the mercury cathode. The amalgam reacts with the water in a separate reactor called decomposer, where hydrogen and caustic soda solution at the commercial concentration of 50 wt % are produced. The mercury and the brine are recycled. Mercury must be removed from the hydrogen gas and caustic soda solution. The cell operates at a \rightarrow *current density* of 8–13 kA m^{-2} , a cell voltage of 3.9–4.2 V, with an energy consumption of 3360 $\text{kWh Mt}^{-1} \text{Cl}_2$ at a current density of 10 kA m^{-2} . Of the three processes, the mercury process has the highest electricity consumption. The mercury cell process is being phased out because of problems with mercury pollution.

(b) Diaphragm process

In the diaphragm (and in the membrane) process, the anode and cathode compartments are separated by a permeable \rightarrow *diaphragm*. The latter generally consist of asbestos, reinforced with fibers of fluorinated polymers, or more recently, they consist of asbestos-free diaphragms, that are instead

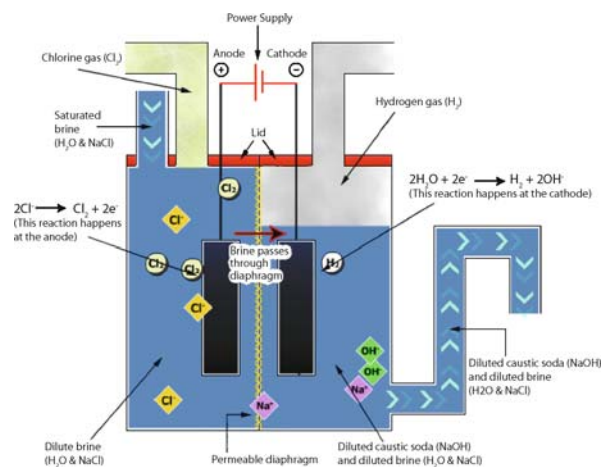

Alkali chloride electrolysis — Figure 2

based on polytetrafluoroethylene (PTFE) with inorganic fillers to increase the \rightarrow *hydrophilicity*. The cathode is typically made of steel. The anode compartment is supplied with saturated brine, which is allowed to percolate through the diaphragm into the cathode compartment, where the soda solution is produced. The brine leaves the cell with an appreciable amount of sodium chloride. The caustic soda must be concentrated to a commercial concentration of 50% using an evaporative process. The salt separated from the caustic brine can be used to saturate the diluted brine. The residual level of salt is 1% which makes this grade of caustic soda unsuitable for some usage. The chlorine contains oxygen and must often be purified by liquefying and evaporation. The cell operates at a current density of 0.9–2.6 kA m^{-2} , a cell voltage of 2.9–3.5 V, with an energy consumption of 2720 $\text{kWh Mt}^{-1} \text{Cl}_2$ at a current density of 1.7 kA m^{-2} . Additional 610 kWh Mt^{-1} of Cl_2 are necessary for the concentration process of 12 to 50% NaOH (steam consumption). Diaphragm, as well as membrane cell type reactors are used to produce sodium hypochlorite (bleach) as side product by the electrolysis of weak brine (or seawater), utilizing cells without a separator (see also \rightarrow *chlor-alkali production*).

(c) Membrane cell process

Anode and cathode are separated by an \rightarrow *ion exchange membrane*, permeable for sodium ions and water only, mainly to prevent the chlorine ions from entering the cathode compartment.

A

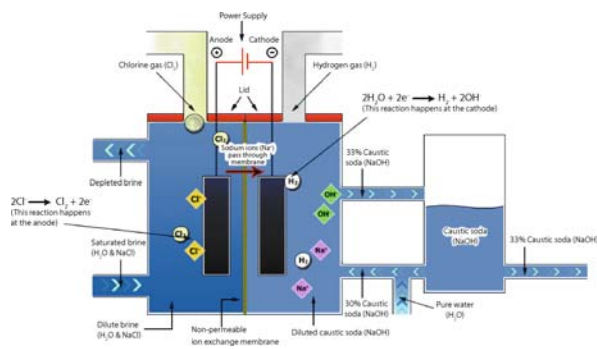

Alkali chloride electrolysis — Figure 3

Nowadays, ion exchange membranes are double-layered, produced from perfluorinated polymers with sulfonic and carboxylic groups grafted on the main polymeric chain. The brine is de-chlorinated and re-circulated. Solid salt is usually needed to re-saturate the brine. After purification by precipitation-filtration, the brine is further purified with an ion exchanger. The caustic solution leaves the cell with about 30% concentration and is usually concentrated to 50%. The chlorine gas, containing some oxygen, is usually purified by liquefying and evaporation. The cell operates at a current density of 3–5 kA m⁻², a cell voltage of 3.0–3.6 V, with an energy consumption of 2650 kWh Mt⁻¹ Cl₂ at a current density of 5 kA m⁻². Additional 180 kWh Mt⁻¹ of Cl₂ are necessary by reason of the concentration process of 33–35% to 50% NaOH (steam consumption). The energy balance sheet of this process is the best of the three processes: The amount of steam needed for concentration of the caustic is relatively small, i.e., less than one ton of steam per ton of caustic soda. The voltage loss in the separator can be reduced to less than 50 mV for a newly installed membrane, as compared with 500 mV for a reinforced asbestos diaphragm. In 2004, the mercury process in Europe accounted for 47% (4,960,000 tons) of production; the membrane process 33.1% (3,490,000 tons); diaphragm 17.4% (1,830,000 tons) and other 2.5% (270,000 tons).

Refs.: [i] Bommaraju TV, O'Brien TF (2005) *Handbook of chlor-alkali technology*. Springer, Berlin; [ii] *Chlorine Industry Review 2004–2005*, EuroChlor

MH_{er}

Alkaline battery — Primary → batteries employing a strongly alkaline aqueous electrolyte solution (e.g.,

KOH), a metal anode (technical term: negative mass, or negative electrode), e.g., zinc, and a metal oxide, e.g., manganese dioxide, with added graphite for enhanced electronic conductivity as cathode (positive mass, – electrode). For zinc, the anode reaction is

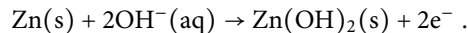

At the cathode manganese dioxide is reduced stepwise according to the following simplified reactions:

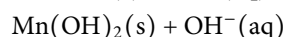
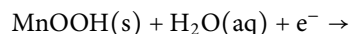
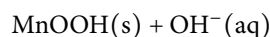
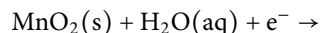

in sum

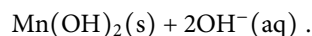
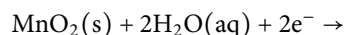

The first step is electrochemically reversible, the second is hardly reversible. Thus a secondary battery can be constructed provided that discharge proceeds only to the end of the first step; this step is indicated by a significant drop in cell voltage. For operation as a secondary system the tendency of the zinc electrode to grow dendrites must be considered. Separators with enhanced mechanical stability and electronic charging devices supplying a pulsed cell voltage may limit the growth and thus the potential damage.

The cell reaction is

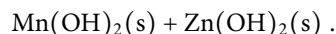
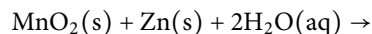

Zn(OH)₂ is soluble in the alkaline solution as [Zn(OH)₃]⁻ until the solution is saturated with K[Zn(OH)₃]. In addition Zn(OH)₂ can be dehydrated to ZnO. An enhanced power density (when compared with the → *Leclanché cell*) is accomplished by using particulate zinc (flakes) soaked with the alkaline electrolyte solution. This anode cannot be used as a cell vessel like in the Leclanché cell. Instead it is mounted in the core of the cell surrounded by the separator; the manganese dioxide cathode is pressed on the inside of the nickel-plated steel can used as battery container. In order to limit self-discharge by corrosion of zinc in early cells mercury was added, which coated the zinc effectively and suppressed hydrogen evolution because of the extremely low exchange current density

of the hydrogen electrode at a zinc surface. In addition, mercury has an activating effect, i.e., it facilitates anodic zinc dissolution. Environmental considerations have stimulated efforts to reduce mercury content. Corrosion is now suppressed by electrolyte solution constituents; the activating effect in the anodic dissolution reaction is provided by modifications in the zinc particle manufacturing process. Instead of manganese dioxide other oxides like, e.g., mercury oxide (\rightarrow *Ruben(-Mallory) cell*) or silver oxide can be employed.

Refs.: [i] Linden D, Reddy TB (eds) (2002) *Handbook of batteries*. McGraw-Hill, New York; [ii] Kozawa A, Yamamoto K, Yoshio M (1999) *Electrochemistry of Manganese Oxides*. In: Besenhard JO (ed) *Handbook of battery materials*. Wiley-VCH, Weinheim, pp 113

Alkaline cell \rightarrow alkaline battery

Alkaline fuel cells (AFC) — The first practical \rightarrow *fuel cell* (FC) was introduced by \rightarrow *Bacon* [i]. This was an alkaline fuel cell using a nickel anode, a nickel oxide cathode, and an alkaline aqueous electrolyte solution. The alkaline fuel cell (AFC) is classified among the low-temperature FCs. As such, it is advantageous over the protonic fuel cells, namely the \rightarrow *polymer-electrolyte-membrane fuel cells* (PEM) and the \rightarrow *phosphoric acid fuel cells*, which require a large amount of platinum, making them too expensive. The fast oxygen reduction kinetics and the non-platinum cathode catalyst make the alkaline cell attractive.

The main drawback of the AFC is the absorption of CO_2 from the air by the alkaline solution. Carbon dioxide reacts with the hydroxide to form carbonate: $2\text{K}^+ + 2\text{OH}^- + \text{CO}_2 \rightarrow \text{K}_2\text{CO}_3 + \text{H}_2\text{O}$, which has limited solubility in concentrated alkali, thus leading to deleterious precipitates within the electrode pores. Although there is no absolute solution to this problem, electrolyte replenishment, and upstream CO_2 scrubbers provide reasonable compromises.

AFCs use as electrolyte an aqueous solution of potassium hydroxide, typically of about 30%.

The overall reactions are:

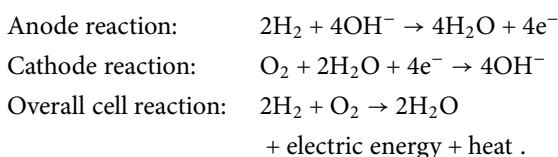

The water and the heat have to be removed. This is usually achieved by circulating the electrolyte and using it as the coolant, while water is removed by evaporation.

Thus, heat and water management are essential issues that have to be considered in the design of fuel cells. A few details on cell construction and the catalyst materials employed are provided in a comprehensive review [ii] from which it is evident that besides platinum, much less expensive materials such as palladium, nickel, and silver can be employed.

Despite the intense activity [iii-x] of developing alkaline fuel cells on an industrial scale for vehicular and space applications, until a year ago none of the several types of fuel cells had reached the cost targets of systems for non-military or non-space applications. Practically all the commercially-marketed systems are mainly demonstrative.

RH As compared to hydrogen, methanol as fuel offers the ease of storage in regular fuel tanks for transportation. This is to be compared to pressurized (400 bar) hydrogen or its storage as a hydride, from which it has to be released in a controllable manner. As seen below, methanol has to be oxidized in a series of electrochemical reactions giving six electrons, water and carbon dioxide.

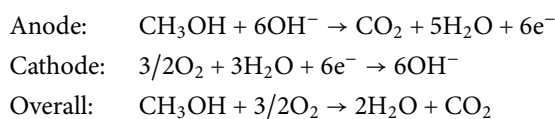

Although most of the research in methanol fuel cells is performed in acidic PEM systems, substantial work is carried out in alkaline systems as well. Interestingly, methanol oxidation in alkaline media is, like hydrogen, more facile. In parallel to the PEM in acidic media, the anion alkaline exchange membrane (AAEM) is adopted for methanol electrooxidation in alkaline solutions. Like PEM, AAEM is also studied as a barrier for methanol crossover.

Methanol electrooxidation is not the only alternative to hydrogen being studied for alkaline fuel cells. Ethanol, ethylene glycol, and other alcohols are also currently being considered.

Refs.: [i] Bacon FT (1960) In: Young GJ (ed) *Fuel cells*, vol. 1. Reinhold Publishing Corp, New York; [ii] McLean GF, Niet T, Prince-Richard S, Djilali N (2002) *Int J Hydrogen Energy* 27:507; [iii] Kordesch K, Gsellmann J, Cifrain M, Voss S, Hacker V, Aronson RR, Fabjan C, Hejze T, Daniel-Ivad J (1999) *J Power Sources* 80:190; [iv] Gulzow E (1996) *J Power Sources* 61:99; [v] Gulzow E (2004) *Fuel Cells* 251:4; [vi] Varcoe JR, Slade RCT (2005) *Fuel Cells* 5:187; [vii] Yu EH, Scott K, Reeve RW (2003) *J Electroanal Chem* 17:547; [viii] Ogumi Z, Matsuoka K, Chiba S, Matsuoka M, Iriyama Y, Abe T, Inaba M (2002) *Electrochem* 70:980; [ix] Gupta SS, Mahapatra SS, Datta J (2004) *J Power Sources* 131:169; [x] Hauffe W, Heitbaum J (1978) *Electrochim Acta* 23:299

A

Alloy deposition — using such technologies as physical vapor deposition (PVD), chemical vapor deposition (CVD), or, most commonly, → *electrodeposition*. Electrodeposition of alloys occurs when more than one element and at least one metal are deposited during a redox process occurring in the plating solution (→ *electroplating bath*). The deposition of alloys is more complicated than the deposition of a single metal due to the complex thermodynamics and kinetics of the process and because several crystallographic structures may be involved. Moreover, electrodeposited phases are not always the thermodynamic equilibrium phases. A variety of microstructures can be obtained. They include fine-grained, columnar, and dendrite structures that are also observed for single metal depositions, and amorphous, multiphase, composition modulated, and metal matrix composite structures. When two metals of significantly different → *standard potentials* (esp. with different → *formal potentials*) are deposited, the composition of the resulting alloy usually strongly depends on the → *deposition potential*. In such case (e.g., for Ni–Cu alloys) a composition modulated (lamellar) deposit may be obtained. In the process of alloy deposition the → *adatoms* of one metal that appear on the plated surface in the early stages of the deposition process can act as either inhibitors or catalysts for the deposition of the other metal ions. In the first case, when the deposition of a more noble metal is inhibited, an anomalous → *codeposition* is observed (e.g., in Fe–Zn alloy deposition). When the deposition of one metal makes possible the deposition of another metal which can not be reduced alone, the so-called ‘induced co-deposition’ is observed (e.g., deposition of tungsten and molybdenum in the presence of an iron-group metal).

Refs.: [i] Winand R (1994) *Electrochim Acta* 39:109; [ii] Landolt (1994) *Electrochim Acta* 39:1075; [iii] Dini JW (1993) *Electrodeposition: The materials science of coatings and substrates (Materials science and process technology series), A handbook, 2nd edn. Noyes Publications, Norwich*

MD

Alloy dissolution — The process of anodic oxidation of an alloy electrode by application of a suitable → *electrode potential*. It leads to dissolved products. Under non-electrochemical conditions the dissolution of an alloy can be performed with a chemical oxidant. The rate of dissolution depends on the structure and homogeneity of the processed material. When the applied potential or, in the case of chemical dissolution, the oxidation potential of the chemical oxidant lays between the formal potentials of the dissolved components, a selective

dissolution will take place. In the case of Ni–Al alloys, a selective dissolution of Al is used to prepare extremely porous nanocrystalline nickel catalyst. In some cases the selective dissolution or the selective oxidation of alloy components leads to the formation of insoluble products which can inhibit or even completely stop the dissolution of the alloy.

Ref.: [i] Dini JW (1993) *Electrodeposition: The materials science of coatings and substrates (Materials science and process technology series), A handbook, 2nd edn. Noyes Publications, Norwich*

MD

Alternating current (AC) — This is an electric → *current* with a periodical reversal of the → *charge* flow. Sinusoidal AC currents can be analytically described by the equation $I = I_{\max} \sin(\omega t + \varphi)$, where I_{\max} is the amplitude, ω is the angular frequency ($\omega = 2\pi f$, with f being the frequency), t is the time, and φ is the phase angle. Another way to describe the AC current is by the equation $I = I_1 e^{i\omega t}$, where I_1 is the complex amplitude, and $i = \sqrt{-1}$. Alternating currents can follow also any other periodical reversals, e.g., square wave, triangular, etc. functions, which can be represented by a Fourier series (see → *alternating voltage*).

The terms AC field and AC potential are, although not strictly correct, used for situations where an electric field is spread between opposite charges which periodically change their **sign** with a certain frequency (e.g., in a sinusoidal or square wave, or triangular way). The correct terms are ‘alternating field’, and ‘alternating potential’. When the charges are not changing their sign this is called a → *DC* system (direct current).

Note that alternating currents can be superimposed to direct currents, in which case the overall current will not necessarily exhibit a reversal of sign. This will not be the case when the direct current is larger than the amplitude of the alternating current.

FS

Alternating current voltammetry → *AC voltammetry*

Alternating voltage — Alternating voltage is a → *potential* difference which changes from the minimum to the maximum value with a certain → *frequency*. The simplest is a sinusoidal voltage $U = U_m \sin(\omega t)$, where U_m is the amplitude, $\omega = 2\pi f$ is the angular frequency and f is the frequency in hertz. If the voltage applied to a → *circuit* containing only linear responding components (→ *resistors*, → *capacitors* and inductors) is sinusoidal and of constant frequency, the → *current* in the circuit is also sinusoidally modulated and has constant amplitude, frequency, and phase. This is the condition referred to as

a steady state alternating current. When resistors, capacitors, and inductors are combined in an alternating current circuit, the \rightarrow impedances of the individual components can be combined in the same way that the \rightarrow resistances are combined in a direct current circuit [i].

Virtually all periodic functions of time can be represented by a Fourier series. Thus, a general periodic voltage can be thought of as a series combination of sinusoidal voltages. For instance, a square wave voltage is defined by a series [ii, iii]:

$$f(t) = \sin(\omega_0 t) + \frac{1}{3} \sin(3\omega_0 t) + \frac{1}{5} \sin(5\omega_0 t) + \dots$$

See also \rightarrow alternating current.

Refs.: [i] Macdonald JR (1987) *Impedance spectroscopy*, Wiley, New York; [ii] Arfken G (1985) In: *Mathematical methods for physicists*. Academic Press, Orlando, p 760; [iii] Butz T (2006) *Fourier transformations for pedestrians*. Springer, Berlin

MLo

β -alumina — is a large family of cation-conducting \rightarrow solid electrolytes, considered initially as a polymorph modification of aluminum oxide (alumina, Al_2O_3). This group is known since 1916 [i] and comprises materials which were among the first known solid Na^+ -conducting electrolytes [ii]. Presently, β -alumina is understood as a family of layered compounds with general formula $\text{BO}_x\text{-Al}_2\text{O}_3$, where B corresponds to mono-, di-, and trivalent cations [iii–v]; further gradation (e.g., β'' , β''' , β'''') is dependent on the B:Al cation ratio. The lattices of β -alumina type materials comprise spinel-type blocks and alternating B–O sheets providing fast cation \rightarrow diffusion. For the sodium-containing system, the Na- β -alumina phase exists in the range of Na:Al cation ratio from 1:11 (stoichiometric) up to approximately 1:8. At the Na:Al ratios of approximately 1:7–1:5, another modification with a similar structure and a higher conductivity (β'' -alumina, $\chi_{573\text{ K}} \approx 20 \text{ S m}^{-1}$) is formed. In order to stabilize the high-conductivity materials, moderate \rightarrow doping with other cations, such as Mg^{2+} , Zn^{2+} , Ca^{2+} , or Li^+ , is necessary. A substantially high mobility of other cations, primarily alkaline and alkaline-earth metal ions, can also be achieved incorporating these ions in the conductivity sheets.

See also \rightarrow NASICON.

Refs.: [i] Rankin GA, Merwin HE (1916) *J Am Chem Soc* 38:568; [ii] Yu Yao YF, Kummer JT (1967) *J Inorg Nucl Chem* 29:2453; [iii] Strom U (1983) *Solid State Ionics* 8:255; [iv] Bates JB (1984) *Mater Sci Forum* 1:135; [v] Kumar PP, Yashonath S (2006) *J Chem Sci* 118:135

VK

Aluminum-air battery — A \rightarrow metal-air battery operating with an aluminum anode in a neutral or alkaline electrolyte solution. At the anode aluminum is oxidized according to

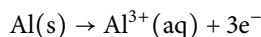

whereas at the cathode oxygen is reduced

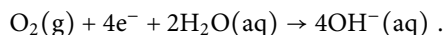

The cell reaction with alkaline solution is

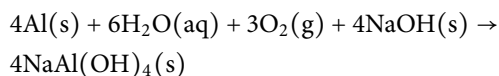

and with neutral solution

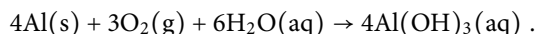

Theoretical data are very attractive because of the negative electrode potential of the aluminum electrode and the large coulombic charge density. In actual tests with neutral electrolyte solution formation of voluminous Al(OH)_3 precipitates causes serious problems in the electrolyte solution management. The limited ionic conductivity even of rather concentrated neutral electrolyte solutions (e.g., 3 M NaCl) results in high internal cell resistances. The low \rightarrow exchange current density of common gas diffusion air electrodes in neutral solution causes electrode potential losses at the cathode whereas the activity of pure aluminum is also smaller in neutral solution than in acidic or alkaline media. \rightarrow Passivation of the aluminum electrode permits storage of filled cells, the passivation layer causes severe losses of cell voltage upon startup. In addition, the removal of these passive layers is uneven resulting in considerable differences in local rates of metal consumption. Open cells (operating in e.g. seawater) may alleviate the problem of hydroxide precipitation. Some of these problems are less drastic with an alkaline electrolyte solution: Ionic conductivity is higher, aluminum is not precipitated but dissolved, the oxygen electrode shows a considerably better potential. Unfortunately corrosion of aluminum is extremely severe, between 8 and 80% of aluminum is consumed in a corrosive side reaction resulting in the formation of large amounts of hydrogen. Together with considerable production of heat this makes cell management difficult. Solubility of NaAl(OH)_4 is large (118 g dm^{-3}) but oversaturated solutions ($\sim 240 \text{ g dm}^{-3}$) tend to show spontaneous precipitation. This causes further difficulties in cell management.

Refs.: [i] Zaromb SJ (1962) *J Electrochem Soc* 109:1125; [ii] Holze R (1982) *Elektrotechnik* 64(9):26; [iii] Li Q, Bjerrum NJ (2002) *J Power Sources* 110:1

RH

Aluminum production — is a large-scale electrometallurgy process giving about a dozen billion tons of primary aluminum metal every year. The still dominating technology has been invented by → *Hall* and → *Hèroult* in the 1880s, and is named → *Hall–Hèroult* or sometimes *Hèroult–Hall* process. The electrolyte used for aluminum production is molten cryolite, however it is not exactly cryolite (Na_3AlF_6) but a mixture of sodium and aluminum fluorides with a cryolite ratio (NaF/AlF_3 molar ratio) of ca. 2.3. Alumina is dissolved in this mixture, and a 2–4 wt% alumina concentration is maintained in the bath. Calcium fluoride (about 5 wt%) serves as an additive to increase melt conductivity. A typical bath operates at ca. 950 °C and at a current density of ca. 0.5 A cm⁻². Consumable carbon anodes forming carbon dioxide are applied (most usually → *Söderberg anodes*). The bottom of the bath is covered with technical graphite which operates as the cathode. As liquid aluminum density is higher than melt density, the product of electrolysis collects at the bottom, which is required to be wetted with aluminum in order to decrease the objectionable rippling of liquid aluminum/melt interface. The advanced manufacturers use titanium diboride coatings to increase graphite wettability. Improvements of bath construction were also proposed, and the most promising is the bipolar bath. For various aspects of aluminum technology see [i]. Starting already in the XIX century, a lot of attempts were made to work out an alternative technology with oxygen-evolving (low-consumable, or inert) anodes [ii]. Oxides, cermets, and oxidized metallic alloys were proposed and tested. The most promising feature of oxygen-evolving anodes is the absence of formation of polyaromatic and fluorocarbon pollutants, and the electrodes are dimensionally stable, so the cathode/anode gap does not have to be continually adjusted. See also → *alcoa process*.

Refs.: [1] Thonstad J, Fellner P (2001) *Aluminum electrolysis. Fundamental of the Hall–Heroult process*, 3rd edn. Aluminum, Düsseldorf; [ii] Keller R, Rolseth S, Thonstad J (1997) *Electrochim Acta* 42:1809

GT

AM0 — Acronym for “Air Mass Zero”. The air mass x is defined as the ratio x between the path length within the atmosphere for rays from the sun to the observation point on earth and the corresponding path length for sun at zenith. Spectrum AM0 corresponds to the solar

spectral → *irradiance* outside the atmosphere of earth (the path length within the atmosphere is zero). This condition can be approximated by a 5777 K black body spectral distribution. The mean annual intensity of solar radiation above the atmosphere is called “solar constant” and is close to 1367 W m⁻². AM0 standard is important for characterization of devices, like photovoltaic cells, used in extraterrestrial applications. See also → *AMI* and → *AM1.5*.

Refs.: [i] Garrison JD, Roeder SBW (1999) *Environmental measurement*. In: Webster JG (ed) *The measurement, instrumentation and sensors handbook*. CRC Press, Boca Raton, pp 73-7-73-9; [ii] Wyszecki G, Stiles WS (2000) *Color science – Concepts and methods, quantitative data and formulae*. Wiley, New York

IH

AM1 — Acronym for “Air Mass 1”. Spectrum AM1 corresponds to solar → *irradiance* at the surface of the earth when the sun is at zenith. It differs from → *AM0* due to the scattering and absorption of radiation by the atmosphere. See also → *AM1.5*.

Refs.: [i] Garrison JD, Roeder SBW (1999) *Environmental measurement*. In: Webster JG (ed) *The measurement, instrumentation and sensors handbook*. CRC Press, Boca Raton, pp 73-7-73-9

IH

AM1.5 — Acronym for “Air Mass 1.5”. Spectrum AM1.5 corresponds to solar → *irradiance* at the surface of the earth for the sun at a solar zenith angle of 48.19°. It is called air mass 1.5 spectrum, because the distance that the radiation travels through the atmosphere is 1.5 times the distance that it travels when the sun is at zenith. AM1.5 is considered a satisfactory standard for characterization of photovoltaic devices used in terrestrial applications. Since AM spectra can be satisfactorily produced with lamps associated to filters, the use of this standard allows the investigation of processes influenced by solar radiation, like photoelectrochemical processes and degradation, under laboratory conditions. See also → *AM0*, → *AMI*.

Refs.: [i] Garrison JD, Roeder SBW (1999) *Environmental measurement*. In: Webster JG (ed) *The measurement, instrumentation and sensors handbook*. CRC Press, Boca Raton, pp 73-7-73-9; [ii] Hulstrom R, Bird R, Riordan C (1985) *Solar Cells* 15:365

IH

Amalgam — is an alloy of mercury and one or more other metals. Amalgams are crystalline in structure, except for those with high mercury content, which are paste or liquid. Known since early times, they were mentioned by Pliny the Elder in the 1st century AD. Sodium

(potassium) amalgam is significant in chlorine (NaOH, KOH) production by electrolysis and as reductant of organic compounds in alkaline solutions. Sodium amalgam is used in the design of the high pressure sodium lamp providing sodium to produce the proper color, and mercury to tailor the electrical characteristics of the lamp. In dentistry, an amalgam of silver and tin, with minor amounts of copper and zinc, is used to fill tooth cavities. Liquid, solid, and paste amalgams of different content are used in electrochemistry as electrode material for preparation of working and reference electrodes. See also → *Gibbs energy of amalgam formation*.

BY

Amalgam electrodes → *working electrodes* made of liquid → *amalgam* are similar to → *mercury electrodes* (→ *dropping mercury electrode* DME and → *hanging mercury drop electrode* HMDE), but they are filled with liquid amalgam of appropriate metal instead of pure mercury. In most cases liquid amalgam electrodes are used for specific purposes, where an interaction between the metal dissolved in mercury (or its compound on an electrode surface) and an analyzed substance is studied [i]. These electrodes can serve as a source of metal cations which are produced by anodic oxidation of the working electrode [ii].

Solid amalgams can be prepared by amalgamation of powders of soft metals. The main advantages of the solid metal amalgam (MeSA) electrodes are: 1) high hydrogen → *overvoltage* (near to that of Hg); 2) satisfactory electrochemical regeneration of surface; 3) easy reintroduction into operating function even after several months' break; 4) long lifetime; 5) low toxicity of the material, comparable with dental amalgams; 6) applicability in mobile laboratories for field work; 7) facile insertion into flow-through systems; 8) use of metals which by themselves cannot be sealed-in into glass (the contact between solid amalgam and inner walls of the glass tube is solution- and mercury-tight); 9) easy formation of the electrode into desired size or shape; 10) simple construction without mobile parts [iii].

The → *electrochemical window* of polished solid silver amalgam electrode (*p*-AgSAE) as for an electrode which does not contain liquid mercury is exceptionally broad. This fact allows the application of *p*-MeSAE for determination of species at rather negative potentials. An important advantage is that the electrodes from solid amalgams of different metals can be prepared in a relatively simple way, and that in their applications specific interactions between these metals and the studied compounds can be utilized.

Silver solid amalgam can be used for the preparation of a → *reference electrode* of second kind (→ *electrode of second kind*) [iv].

See also → *Gibbs energy of amalgam formation*.

Refs.: [i] Glodowski S, Bilewicz R, Kublik Z (1987) *Anal Chim Acta* 201:11; [ii] Bond AM, Bobrowski A, Scholz F (1991) *J Chem Soc Dalton Trans* 411; [iii] Yosypchuk B, Novotný L (2002) *Crit Rev Anal Chem* 32:141; [iv] Yosypchuk B, Novotný L (2004) *Electroanalysis* 16:238

BY

Ambipolar conductivity — Symbol: σ_{amb} , SI unit: S m^{-1} . Ambipolar → *conductivity* is the proportionality coefficient between the steady-state flux $J_{B^{z\pm}}$ of $B^{z\pm}$ ions and the → *chemical potential* gradient $\nabla\mu_B$ of the neutral species B under zero-current conditions, when the charge transfer due to the $B^{z\pm}$ ion flux is compensated by the fluxes of other species $A^{n\pm}$ (electrons or other sort(s) of ions): $J_{B^{z\pm}} = -\frac{\sigma_{\text{amb}}}{(zF)^2\nu_B}\nabla\mu_B$ (F → *Faraday constant*). In a system with two → *charge carriers* $zJ_{B^{z\pm}} = -nJ_{A^{n\pm}}$ and the ambipolar conductivity is expressed via the partial → *conductivities* of these species ($\chi_{B^{z\pm}}$ and $\chi_{A^{n\pm}}$) or via the corresponding → *transport numbers*: $\sigma_{\text{amb}} = \frac{\chi_{A^{n\pm}}\chi_{B^{z\pm}}}{\chi_{A^{n\pm}} + \chi_{B^{z\pm}}} = t_{A^{n\pm}} \cdot t_{B^{z\pm}} \cdot \chi$ where χ is the total conductivity. These equations can be derived by solving the → *Wagner equation* or → *Onsager equation*, in combination with the definition of → *conductivity* and the corresponding boundary conditions [i–iv]. For systems with three or more mobile species, the relationships between ambipolar and partial conductivities are more complex, depending on the migration mechanisms and properties of the → *ionic conductor* [iii].

The physical meaning of the ambipolar conductivity relates to the correlated transport of several charge carriers, when an internal → *electrical field* in the system impedes the migration of species with a higher → *mobility*, but enhances transfer of less mobile species.

The phenomenon of ambipolar conduction is not limited to chemical potential gradients only, and may occur in systems with several driving forces (e.g., chemical-potential and temperature gradients in combination with external electrical field). However, this phenomenon is always related to conjugate transport of several charge carriers.

The quantity of ambipolar conductivity is widely used for the analysis of → *electrolytic permeability* of → *solid electrolytes*, caused by the presence of electronic conductivity. Other important cases include transient behavior of electrochemical cells and ion-conducting solids, dense ceramic membranes for gas separation, reduction/oxidation of metals, and kinetic demixing phenomena [iv]. In most practical cases, however, the ambipo-

lar conductivity is determined by the transport of one sort of mobile ions and electronic charge carriers: $\sigma_{\text{amb}} = \frac{\chi_e \chi_{B^{z\pm}}}{\chi_e + \chi_{B^{z\pm}}} = (1 - t_{B^{z\pm}}) \cdot t_{B^{z\pm}} \cdot \chi$ where χ_e is the partial electronic conductivity comprising both *p*- and *n*-type contributions. When using \rightarrow Fick's laws, the \rightarrow ambipolar diffusion coefficient \tilde{D}_B is typically used instead of the ambipolar conductivity: $\tilde{D}_B = \frac{\sigma_{\text{amb}}}{(zF)^2 \nu_B} \frac{\partial \mu_B}{\partial c_{B^{z\pm}}}$.

Notice that \tilde{D}_B is also called "chemical \rightarrow diffusion coefficient". Sometimes this term may appear misleading due to mixing up with another quantity $\tilde{D}_{B^{z\pm}} = D_{B^{z\pm}} \frac{\partial \ln a_{B^{z\pm}}}{\partial \ln c_{B^{z\pm}}} = \frac{RT \chi_{B^{z\pm}}}{(zF)^2 c_{B^{z\pm}}} \cdot \frac{\partial \ln a_{B^{z\pm}}}{\partial \ln c_{B^{z\pm}}}$ which is often called "chemical diffusion coefficient of $B^{z\pm}$ ions" or "partial chemical diffusion coefficient of $B^{z\pm}$ ions". Here $D_{B^{z\pm}}$ corresponds to the classical meaning of the diffusion (self-diffusion) coefficient used in Fick's laws.

Other definitions of chemical diffusion coefficients were also suggested for various particular cases (e.g., see [iii, vi–viii]). In all cases, however, their physical meaning is related either to the ambipolar diffusion or to diffusion in non-ideal systems where the activity coefficients differ from unity.

The right terms in the two last equations, namely $(\partial \mu_B / \partial c_{B^{z\pm}})$ and $(\partial \ln a_{B^{z\pm}} / \partial \ln c_{B^{z\pm}})$, are both called the thermodynamic or \rightarrow Wagner factors [iii, iv]. The first of them can be determined experimentally from the ion concentration dependence on the chemical potential of neutral species (*a*-*T*- δ diagram). The direct determination of the second factor is impossible as the chemical potentials of charged species cannot be explicitly separated from those of other components of a system; this parameter can be assessed indirectly, analyzing activities of all components.

Refs.: [i] Wagner C (1936) *Z phys Chem B* 32:447; [ii] Yokota I (1961) *J Phys Soc Jap* 16:2213; [iii] Chebotin VN (1989) *Chemical diffusion in solids*. Nauka, Moscow; [iv] Bouwmeester HJM, Burggraaf AJ (1996) *Dense ceramic membranes for oxygen separation*. In: Burggraaf AJ, Cot L (eds) *Fundamentals of inorganic membrane science and technology*. Elsevier, Amsterdam, pp 435–528; [v] Rickert H (1982) *Electrochemistry of solids. An introduction*. Springer, Berlin; [vi] Wagner JB (1973) *Diffusion in non-stoichiometric compounds*. In: Kuczynski GC (ed) *Materials science research. Sintering and related phenomena*, vol. 6. Plenum Press, New York, pp 29–47; [vii] Kröger FA (1964) *The chemistry of imperfect crystals*. North-Holland, Amsterdam; [viii] Maier J (1998) *Solid State Ionics* 112:197

VK

Amicron — Obsolete term suggested by \rightarrow Zsigmondy to designate particles smaller than 1 nm, as they were invis-

ible in the ultramicroscope of his time. See also \rightarrow *colloid*, \rightarrow *microscopy*.

FS

Ammeter (amperemeter, galvanometer) — Instrument for measuring \rightarrow current. Modern multipurpose instruments are digital \rightarrow *multimeter* using the charging of a \rightarrow capacitor and an \rightarrow analog-to-digital converter. Historically, moving-coil galvanometer and moving-iron galvanometer have been of importance. In case of \rightarrow ultramicroelectrodes pico- and femtoamperemeters have to be used, unless arrays of ultramicroelectrodes (\rightarrow array electrodes) are utilized. Instruments for \rightarrow voltammetry use \rightarrow operational amplifiers for current measurement and amplification. See also \rightarrow astatic galvanometer, \rightarrow mirror galvanometer, \rightarrow galvanoscope.

Ref.: <http://physics.kenyon.edu/EarlyApparatus/>

FS

Ammonia reserve battery \rightarrow reserve battery

"Ammonium amalgam" — In 1808, T.J. Seebeck placed mercury in a cavity cut in a piece of ammonium carbonate resting on a metal plate; the latter was placed in connection with the positive pole, and the mercury with the negative pole of a battery. The mercury swelled up into a frothy mass, with the consistency of butter. The product was considered to be ammonium amalgam. Davy prepared ammonium amalgam by placing mercury containing about one percent of sodium, potassium, or barium in moistened ammonium salt, in aqueous solution of ammonium salt, or a solution in concentrated aqueous ammonia. In different experiments mercury swells up to 5–30 times its original bulk. Ammonium amalgam is not stable at normal conditions and it decomposes with water into liquid mercury and a mixture of approximately 1 vol. of hydrogen and 2 vols. of ammonia [i]. Ammonium amalgam after preparation should be kept frozen at -78°C , at which temperature no decomposition is detectable.

Two reduction signals (at -1.20 V and at -1.75 V vs. SHE) [ii] are observed on mercury electrodes in aqueous solutions of ammonium salts. Probably, at lower negative potential ammonium hydride amalgam is created according to the reaction:

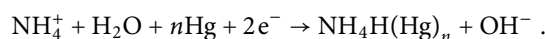

Ammonium ion is reduced at about -1.7 V and creates amalgam of ammonium radical:

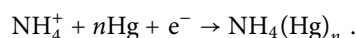

Using \rightarrow *anodic stripping voltammetry* (ASV) two stripping peaks are observed on mercury surface in the mentioned potential range which corresponds to oxidation of two types of amalgams. The ASV peak of ammonium hydride amalgam is reproducible, it linearly grows well with increase of NH_4^+ ions concentration, and it is applied for determination of small amounts of ammonium ions (sensitivity $2 \times 10^{-7} \text{ mol L}^{-1}$) in aqueous solutions.

Ammonium amalgams are Zintl phase salts with mercury anions [iii–iv].

Refs.: [i] Mellor JW (1923) *A comprehensive treatise on inorganic and theoretical chemistry*. Longmans, Green and Co, London; [ii] Gladyshev VP, Kovaleva SV, Khramtsova NA (2001) *J Anal Chem (Moscow)* 56:503; [iii] Garcia E, Cowley AH, Bard AJ (1986) *J Am Chem Soc* 108:6082; [iv] Kariv-Miller E, Lehman GK, Svetličič V (1997) *J Electroanal Chem* 423:87

BY

Ammonia sensor — Sensor for the measurement of the concentration of dissolved ammonia in solution. A pH-probe (e.g., a \rightarrow *glass electrode*) is covered with a gas-permeable membrane. An electrolyte solution (e.g., an aqueous solution of NH_4Cl) is placed between the membrane and the sensor. The pH of this solution is affected by NH_3 diffusing through the membrane and dissolved into the solution. Volatile amines may cause measurement errors. Ammonium ions can be determined only when they are deprotonated (by adjusting the pH-value in the sample solution to $\text{pH} > 11$) and thus can be present both in the solution and in the gas phase, i.e., can transfer through the membrane. Because of the operational principle this sensor may respond to every acidic or basic gas diffusing through the membrane. Consequently, this sensor as well as similar devices (see e.g., \rightarrow *carbon dioxide sensor*) are basically gas-sensitive, but not gas-selective. Nevertheless some selectivity can be afforded by, e.g., choice of the membrane or actual composition of the electrolyte solution.

Ref.: [i] Ross JW, Riseman JH, Krueger JA (1973) *Pure Appl Chem* 36:473

RH

Ampere — SI basic measurement unit of the electric \rightarrow *current*. Symbol: A (named in honor of \rightarrow *Ampère* (1775–1836))

The ampere is that constant current which if maintained in two straight parallel conductors of infinite length, of negligible circular cross-section, and placed one meter apart in vacuum, would produce between these conductors a force of 2×10^{-7} newtons per meter

conductor length. 1 ampere equals the flow of 1 coulomb per second, i.e., $6.24150948(54) \times 10^{18}$ electrons (or elementary charges) per second. See also \rightarrow *coulomb*, \rightarrow *elementary charge*.

Ref.: [i] Cohen ER, Cvitas T, Frey JG (eds) (2006) *IUPAC quantities, units and symbols in physical chemistry*, p 87

BM

Ampère, André Marie



(Jan 22, 1775, Lyon, France – June 10, 1836, Marseille, France) Much of his early education was based on the *L'Encyclopédie* of d'Alembert and Diderot, but his interest in physics and chemistry derived from reading the works of Lavoisier. In 1801 he became lecturer in Bourg, and in 1804 in Lyon. Later that year he moved to Paris, where he eventually became Professor at the École Polytechnique, and in 1826 at the Collège de France. In 1814 he became a member of the Academy. Ampère was one of the most important universal scientists of the 19th century. His scientific achievements concern mathematics, physics, and chemistry. He is recognized as one of the founders of electrodynamics, following the discovery of the effect of an electric current on a magnet by \rightarrow *Ørsted*. The basic SI unit of current has been named in his honor, the \rightarrow *ampere*.

Ref.: [i] Ostwald W (1896) *Elektrochemie. Ihre Geschichte und Lehre*. Veit, Leipzig (Engl transl: Ostwald W (1980) *Electrochemistry. History and theory*, vol. 2. Amerind Publ Co, New Delhi)

FS

Ampere-hour — A common unit of charge in the battery field. The amount of electricity that passes during one hour at a current of one ampere. One ampere-hour (Ah) equals 3600 coulombs. The capacity of cells and batteries is universally specified in terms of ampere-hours or milliampere-hours. The term ampere-hour as a unit of charge measuring is used also, although to a lesser degree, in the electroplating industry.

A

Refs.: [i] Linden D (1994) *Basic concepts*. In: Linden D (ed) *Handbook of batteries*, 2nd edn. McGraw-Hill, New York, p. 1.8 and Appendix A, p. A.1 & 1.8.; [ii] Nagy Z (ed) (2005) *Online electrochemistry dictionary*. <http://electrochem.cwru.edu/ed/dict.htm>; [iii] Graf RF (1999) *Modern dictionary of electronics*, 7th edn. Newnes, Oxford; [iv] Latter T (1996) *Current-time integration*. In: Murphy (ed) *Metal finishing*, vol. 64 edn. Elsevier, New York, pp 542–544

Ampere-hour efficiency — A term that quantifies the efficiency of electricity storage and conversion in secondary batteries. Ampere-hour efficiency, sometimes referred to also as columbic efficiency, is defined as the ratio between the amount of charge consumed during cell (or battery) charging, to the amount of charge delivered by the cell during its discharge, at given condition of temperature, load, charging current density, etc. Ampere-hour efficiency does not take into account electricity losses by the charger.

Refs.: [i] Schiffer SF, Karpinski PA (1994) *Silver oxide batteries*. In: Linden D (ed) *Handbook of batteries*, 2nd edn. McGraw-Hill, New York, p 31.8 and Appendix A; [ii] Nagy Z (2005) *Online electrochemistry dictionary*. <http://electrochem.cwru.edu/ed/dict.htm>; [iii] Graf RF (1999) *Modern dictionary of electronics*, 7th edn. Newnes, Oxford

Amperemeter → *ammeter*

Amperometry — a current (mostly a → *faradaic current*) is measured as a function of another experimental variable, e.g., concentration, volume of added reagent in analytical applications, or time. When faradaic current is measured as a function of electrode potential the method is called → *voltammetry* (derived from → *volt* and → *ampere*), measurement as a function of time is called → *chronoamperometry*. See also → *amperometric sensor*.

Refs.: [i] Bard AJ, Faulkner LR (2001) *Electrochemical methods*. Wiley, New York, pp 437–440; [ii] Brett CAM, Oliveira Brett AM (1993) *Electrochemistry*. Oxford University Press, Oxford, pp 311–314

Amperometric sensors — A class of electrochemical sensors based on → *amperometry*. A → *diffusion-limited current* is measured which is proportional to the concentration of an electrochemically active analyte. Preferred technique for → *biosensors* with or without immobilized enzymes (biocatalytic sensors). The diffusion layer thickness must be kept constant, either by continuous stirring or by means of an external diffusion barrier. Alternatively, → *microelectrodes* can be

used. A constant potential in the current-limited range of the corresponding → *voltammogram* has to be imposed.

Example: → *Clark cell* for determination of dissolved oxygen.

Refs.: [i] Janata J (1989) *Principles of chemical sensors*. Plenum, New York; [ii] Brett CMA, Oliveira Brett AM (1993) *Electrochemistry*. Oxford University Press, Oxford, pp 289; [iii] Gründler P (2007) *Chemical Sensors*. Springer, Berlin; [iv] Eggins BR (2002) *Chemical sensors and biosensors*. Wiley, New York

PG

Amperometric titration → *Titration* in which the course of the reaction is monitored by the current that flows through an → *indicator electrode* that is kept at a constant → *electrode potential*. Amperometric titration curves are generally linear before and after the equivalence point, which allows a precise determination of the equivalence point by measuring a number of data points before and after that point and interpolating the point where the two linear lines cross. Amperometric titrations were also called polarographic or polarometric titrations (when using a → *dropping mercury electrode*), or generally ‘limiting current titrations’.

See also → *biamperometry*, and → *amperometry*.

Refs.: [i] Kolthoff IM, Lingane JJ (1952) 2nd edn. *Polarography. Polarographic analysis and voltammetry. Amperometric titrations*. Interscience, New York, vol. 2, pp 887; [ii] Heyrovský J, Kuta J (1966) *Principles of polarography*. Academic Press, New York, pp 267; [iii] *Classification and nomenclature of electroanalytical techniques* (1976) *Pure Appl Chem* 45:81; [iv] Bard AJ, Faulkner LR (2001) *Electrochemical methods*, 2nd edn. Wiley, New York, pp 437

FS

Amperostat — An electronic control circuit designed for stabilizing an electrolysis current, either keeping it at an arbitrarily adjustable constant value, or varying it according to a predetermined time function. Often used synonymously with → *galvanostat*. Fields of application: → *coulometric titration* (with constant current) also named → *coulometry*, *constant current coulometry*. Also used for small amplitude techniques utilizing constant current like → *chronopotentiometry* or → *potentiometric stripping*.

Amperostatic control is easier than potentiostatic. Therefore they predominated, preferably in coulometry, before the appearance of the potentiostat in 1942.

Ref.: [i] Kissinger PT (1996) *Introduction to analog instrumentation*. In: Kissinger PT, Heineman WR (eds) *Laboratory techniques in electroanalytical chemistry*, 2nd edn. Marcel Dekker, New York, pp 165–194

PG

Amphiphatic compounds → *amphiphilic compounds*

Amphiphilic compounds — Compounds that possess both a hydrophilic and a hydrophobic part. Examples are carbonic acids, having a hydrophobic alkyl chain and a hydrophilic carboxyl group, lecithins, lipids, and many other organic compounds. See also → *hydrophilicity*, and → *hydrophobic effect*.

Ref.: [i] Tanford C (1973, 2nd edn. 1980) *The hydrophobic effect: Formation of micelles and biological membranes*. Wiley, New York

FS

Amphiprotic solvents — These are solvents that behave as acids in the presence of basic solutes and as bases in the presence of acidic solutes [i–iii]. In contrast to aprotic solvents, amphiprotic solvents undergo self-ionization. Self-ionization or → *autoprotolysis* is the transfer of a hydrogen ion between molecules of the same substance. Hence, amphiprotic solvents represent both Brønsted acids and bases. Examples of amphiprotic solvents are water, carboxylic acids, alcohols, phenols, ammonia, and amines. For example, acetic acid can be considered as an amphiprotic solvent because it can act both as a proton donor and as an acceptor. The dissociation constant of its autoprotolysis, which proceeds in accordance with the equation: $2\text{CH}_3\text{COOH} \rightleftharpoons \text{CH}_3\text{COOH}_2^+ + \text{CH}_3\text{COO}^-$, was found to be equal to 2.5×10^{-13} at 25 °C [iv]. The advantage of using amphiprotic solvents as electrolyte solution components is their high polarity, which enables highly conductive solutions to be obtained. However, as compared to aprotic solvents, they possess narrow electrochemical windows [ii].

Refs.: [i] Reichardt C (2003) *Solvents and solvent effects in organic chemistry*, 3rd edn. Wiley-VCH, Weinheim; [ii] Aurbach D, Gofar Y (1999) *The electrochemical window of nonaqueous electrolyte solutions*. In: Aurbach D (ed) *Nonaqueous electrochemistry*. Marcel Dekker, New York, pp 137–212; [iii] Komorsky-Lovrić Š (2002) *Electrolytes*. In: Scholz F (ed) *Electroanalytical methods*. Springer, Berlin, pp 279–299; [iv] Kolthoff IM, Willman A (1934) *J Am Chem Soc* 56:1007

DA, EM

Ampholyte — A substance that can react both as an acid and as a base is called an ampholyte, or amphoteric compound. Usually this property refers to the → *Brønsted acid–base theory*. An example is HCO_3^- which can act as a proton acceptor and as a proton donor. An ampholyte can be a → *zwitterion*, as in case of amino acids: in the range between $\text{pH} = \text{p}K_{\text{a}1}$ and $\text{pH} = \text{p}K_{\text{a}2}$, they exist as $[\text{H}_3\text{N}^+\text{HRC}-\text{COO}^-]$.

RH

Amphoteric — a substance that can act both as an acid and a base: → *acid–base theories*, subentry → *base–antibase concept*, → *ampholyte*, → *Bjerrum*, *Niels Janiksen*, → *capillary isoelectric focusing (CIEF)*, → *metals*.

Occasionally, compounds that can be oxidized and reduced are called amphoteric [i, ii].

Refs.: [i] Nakasuji K, Yoshida K, Murata I (1983) *J Am Chem Soc* 105:5136; [ii] Perepichka DF, Bryce MR, Perepichka IF, Lyubchik SB, Christensen CA, Godbert N, Batsanov AS, Levillain E, McInnes EJJ, Zhao JP (2002) *J Am Chem Soc* 124:14227

AJB

Amplifiers (amps) — Electronic devices that are used to increase the current, voltage, or both of a measured signal. The output of an amplifier is controlled in such a way that it matches the input signal shape but has a larger amplitude. The amplifiers can be inverting (the output is 180 degrees out of phase of the input signal) or non-inverting (equal phase relationship between the input and output waveforms is maintained). There are several other classes of amplifiers, e.g., a linear amp is that which provides a precise amplification factor over a wide range of frequencies. Operational amplifiers that are widely used in electrochemical instrumentation are packaged integrated circuits with special properties. They work as current (scalers, adders, integrators, differentiators) or voltage followers.

Lock-in amplifier — A device that measures an AC voltage (or current) and transforms it into a DC voltage signal proportional to the intensity of the examined AC signal. The DC voltage of the output is usually greater than the AC voltage of the input, therefore the device is named amplifier. The term ‘lock-in’ appears because this amplifier locks to and measures the preselected frequency while all other signals appearing at the input are ignored.

The key element of this amplifier is a phase sensitive detector. It demodulates the frequency of interest and produces a signal, which is a function of the phase angle of the input signal. The input circuit of a lock-in amplifier is properly adjusted to achieve the ability of the device to recover signals that are overloaded with → *noise*.

Recently developed digital signal-processing (DSP) lock-in amplifiers open new possibilities in measurement. It is possible, among others, to simultaneously measure two different frequency components of the input signal.

Refs.: [i] Bard AJ, Faulkner LR (2001) *Electrochemical methods. Fundamentals and applications*. 2nd edn. Wiley, New York, chap 15; [iii] <http://www.signalrecovery.com/lockinex.htm>

ZS

A

Analog filter — An electronic circuit that handles continuous signals and provides high impedance to a desired range of frequencies. The actual amount of attenuation for each frequency varies from filter to filter [i, ii]. Analog filters can be divided into two broad groups:

- **Passive filter** A kind of usually simple filters composed of elements such as resistors (R), capacitors (C), and inductors (L) that do not depend upon an external power supply. There are different passive filters such as the so-called RC, RL, LC, and RLC varieties. Inductors block high-frequency signals and conduct low-frequency signals, while capacitors do the reverse. Resistors have no frequency-selective properties, but are added to inductors and capacitors to determine the time-constant of the circuit.
- **Active filter** A type of device composed of a combination of passive and active (amplifying) components. Frequently, the latter are transistors or operational amplifiers that require an external power supply to work. Active components commonly have high Q , and achieve resonance without the use of inductors. The Q value (goodness factor) is used to measure the quality of a filter. Thus, a filter has a high Q if it selects or rejects a narrow range of frequencies compared with its center frequency. Other filters that can be included into this class are:
 - **Piezoelectric filter** A kind of electromechanical device in which electrical signals are converted to a mechanical wave by using a piezoelectric crystal. Thus, the former electric wave is delayed as it propagates across the crystal, and this delay is used to reinforce a desired frequency bandwidth with very high Q values. The quartz crystal is an example of the piezoelectric elements used for these filters [i].
 - **Atomic filter** A sort of device with an ultra-high Q obtained by using the vibrations of atoms. These systems employ the microwave amplification by stimulated emission of radiation (maser) of substances such as cesium or ruby to stabilize the primary oscillator of extremely precise devices that work at high frequency values [i].

Refs.: [i] Horowitz P, Hill W (2001) *The art of electronics*. Cambridge University Press, Cambridge; [ii] Willard HH, Merritt LL, Dean JA, Set-

tle FA (1988) *Instrumental methods of analysis*. Wadsworth, California

FG

Analog-to-digital converter (ADC or A/D) — A device that converts continuous signals to discrete binary digital numbers proportional to the amplitude of the analog signal. Commonly, these are electronic devices that convert a voltage or current to a digital binary number. The reverse operation is performed by a \rightarrow *digital-to-analog converter* (DAC). There are two types of resolution related to these converters. The first indicates the number of discrete values that it can produce, while the second is associated with the number of discrete values in which its overall voltage measurement range can be divided. Both kinds of resolution are usually expressed in bits. For example, a resolution of eight bits can be encoded into $2^8 = 256$ discrete values [i, ii].

Refs.: [i] Horowitz P, Hill W (2001) *The art of electronics*. Cambridge University Press, Cambridge; [ii] Engineering Staff Analog Devices Inc (2005) *The data conversion handbook*. Newness, Oxford

FG

Analyte — A component of a \rightarrow *sample* to be analyzed [i].

Ref.: [i] Skoog D, West D, Holler F (1996) *Fundamentals of analytical chemistry*. Saunders, New York

FG

Anaphoresis — [Greek] Movement of negatively charged colloidal particles in a suspension towards the anode (see also: \rightarrow *cataphoresis*, \rightarrow *electrokinetic phenomena*).

RH

Anderson cell — This was a \rightarrow *battery* with a zinc electrode in sulfuric acid or hydrochloric acid (or salts of these acids) and a carbon electrode in a solution of oxalic acid and chromic acid.

See also \rightarrow *chromic acid battery*, \rightarrow *Daniell cell*, \rightarrow *zinc*, \rightarrow *Zn²⁺/Zn electrodes*, \rightarrow *Zn²⁺/Zn(Hg) electrodes*, \rightarrow *zinc-air batteries (cell)*, and \rightarrow *Leclanché cell*.

Ref.: [i] Hauck WP (1883) *Die Galvanischen Batterien, Accumulatoren und Thermosäulen*, 2nd edn. Hartleben's Verlag, Wien

FS

Angular frequency \rightarrow *angular velocity*

Angular velocity (angular frequency) — $\omega = d\phi/dt$, i.e., the change of the angle of rotation $d\phi$ in time dt (i.e., first derivative of angle of rotation $d\phi$ in time dt). In case of a monotonous circular movement it is $\omega = 2\pi f$

with f being the frequency of rotation (see → *rotating disc electrode*, → *rotating ring-disc electrode*).

RH

Anharmonic oscillator — When the restoring force of an oscillating system does not depend linearly on the displacement of the system from the equilibrium position, the oscillator is referred to as anharmonic. The restoring force may correspond to a superposition of first and higher powers of the displacement.

FS

Anion — A negatively charged ion. An anion has more electrons than protons and is attracted by a positively charged → *electrode*. The name *ion* was created by → *Faraday*, from Greek *ίόν*, neutral present participle of *ίέναι*, “to go”, so *anion*, *άνιόν*, means “(a thing) going up”.

BM

Anion-induced adsorption → *induced adsorption*

Anion vacancies → *vacancies*

Anode — Electrode where → *oxidation* occurs and electrons flow from electrolyte to electrode. At the other electrode, which is called a → *cathode*, electrons flow from electrode to electrolyte. It follows that in a → *battery*, the anode is the negative electrode. In → *electrolysis*, to the contrary, the anode is the positive electrode. Note that the concepts of “anode” and “cathode” are related only to the direction of electron flow, not to the polarity of the electrodes. The terms “anode” and “cathode” as well as “anion”, “cation”, “electrolyte”, etc. were introduced by → *Faraday*, who considered that anions migrated toward the anode, while cations migrated toward the cathode (see also → *Whewell*). However, it should be noted that the redox species, which gives electrons to the anode, is not necessarily an anion.

TO

Anode effect — refers to the sudden increase in voltage and decrease in current that happens when a gas film forms on the anode during electrolysis in melted salts. It is of special importance in → *aluminum production* (→ *Hall-Héroult process*).

Ref.: [i] Haverkamp RG (2000) *Aluminum Transactions* 2169

FS

Anode, low consumable — This term is used for different anodes that show a low dissolution rate: (a) in cathodic protection (→ *corrosion*, and subentry → *corrosion protection*) that are anodes that form a protective

layer so that they are not or only slowly dissolving when anodically polarized [i].

(b) In certain technical processes, e.g., the electrolytic aluminum production, anodes that are not, or only slowly dissolving. See also → *Hall-Héroult process*. See also → *dimensional stable electrodes*.

Ref.: [i] Juchniewicz R, Jankowski J, Darowicki K (2000) *Cathodic and anodic protection*. In: Schütze M (ed) *Corrosion and environmental degradation*, vol. 1. Wiley-VCH, Weinheim, pp 383

FS

Anode mud — During the anodic dissolution of an impure electrode (e.g., in an → *electrorefining* or → *electrodeposition* process) a residue may form which is called anode mud or anode slime. It contains elements which are insoluble under the conditions of the → *electrodissolution* process and thus sediment near the anode. Usually the anode mud contains precious metals (Ag, Au, Pt, etc.) which are recovered from it.

AB

Anode, sacrificial — a rather easily oxidizable metal, e.g., zinc, magnesium, aluminum, electrically connected with a metal construction to be protected from corrosion. Due to the formation of a → *galvanic cell* the sacrificial anode is oxidized instead of the metal to be protected. Sacrificial anodes are the oldest and simplest means for electrochemical corrosion protection.

Ref.: [i] Juchniewicz R, Jankowski J, Darowicki K (2000) *Cathodic and anodic protection*. In: Schütze M (ed) *Corrosion and environmental degradation*, vol. 1. Wiley-VCH, Weinheim, pp 383

FS

Anode slime → *anode mud*

Anodic corrosion protection → *corrosion protection*

Anodic partial current (density) — For a single → *electrode reaction*, the total current is composed of an anodic and a cathodic → *partial currents*.

When the rate is controlled by the → *charge transfer* step according to the → *Butler-Volmer equation* the anodic partial current density (j_a) can be expressed as follows:

$$j_a = j_o \exp\left(\frac{\alpha_a n F \eta}{RT}\right) \quad (1)$$

assuming that $c_R(x = 0) \approx c_R^*$ which is the case in intensively stirred solutions; j_o is the → *exchange current density*, α_a is the anodic → *transfer coefficient*, n is the → *charge number* of the electrode reaction, F is the → *Faraday constant*, R is the → *gas constant*, T is the temperature, η is the → *overpotential*, $c_R(x = 0)$ and c_R^* are the concentrations of the reacting species (reduced form

A

of the redox couple) at the electrode surface and the bulk solution, respectively.

By using the \rightarrow formal potential ($E_c^{\ominus'}$) and the \rightarrow standard rate constant (k_s)

$$j_a = nFk_s c_R(x=0) \exp\left(\frac{\alpha_a nF(E - E_c^{\ominus'})}{RT}\right), \quad (2)$$

where E is the \rightarrow electrode potential. When $c_R(x=0)$ is substantially higher or lower than c_R^*

$$j_a = j_o \frac{c_R(x=0)}{c_R^*} \exp\left(\frac{\alpha_a nF\eta}{RT}\right). \quad (3)$$

In the potential region of \rightarrow diffusion \rightarrow limiting current ($j_{L,a}$)

$$j_{L,a} = nFk_{mR} c_R^*, \quad (4)$$

where k_{mR} is the \rightarrow mass transport coefficient.

In the potential region where mixed kinetic-diffusion control prevails

$$j_a = j_o (1 - j_a/j_{L,a}) \exp\left(\frac{\alpha_a nF\eta}{RT}\right). \quad (5)$$

The anodic partial current may be a sum of several partial currents when two or more electrode processes take place simultaneously (see \rightarrow partial current); for instance, the evolution of chlorine and oxygen from aqueous hydrochloric acid solutions at high positive potentials.

In this case

$$j_a = j_{1,a} + j_{2,a} \quad (6)$$

$$j_a = j_{o,1} \frac{c_{R,1}(x=0)}{c_{R,1}^*} \exp\left(\frac{\alpha_{a,1} n_1 F \eta}{RT}\right) + j_{o,2} \frac{c_{R,2}(x=0)}{c_{R,2}^*} \exp\left(\frac{\alpha_{a,2} n_2 F \eta}{RT}\right). \quad (7)$$

Refs.: [i] Erdey-Grúz T, Volmer M (1930) *Z Phys Chem* A150:203; [ii] Parsons R (1974) *Pure Appl Chem* 37:503; [iii] Inzelt G (2002) *Kinetics of electrochemical reactions*. In: Scholz F (ed) *Electroanalytical methods*. Springer, Berlin, pp 29–33; [iv] Bard AJ, Faulkner LR (2001) *Electrochemical methods*. 2nd edn. Wiley, New York, pp 98–103

Anodic stripping voltammetry — Refers to a family of procedures involving a \rightarrow preconcentration by electrochemical reduction of the \rightarrow analyte (or a salt or derivative of the analyte) onto (or into) the working electrode prior to its direct or indirect determination by means of

an electroanalytical technique (see \rightarrow stripping voltammetry) [i–iv]. An example is the reductive preconcentration of lead according to $Pb^{2+} + 2e^- \rightarrow Pb$ (the lead may be deposited on the surface of a mercury drop, where it would dissolve in a surface layer) and its anodic dissolution during a voltammetric scan according to $Pb \rightarrow Pb^{2+} + 2e^-$. The latter scan produces a peak current that is proportional to the concentration of Pb^{2+} in the analyte solution. Due to the preconcentration step, anodic stripping voltammetry excels in sensitivity, which can be even enhanced when \rightarrow differential pulse or \rightarrow square-wave-voltammetry are used to perform the voltammetric dissolution measurement, as these techniques additionally discriminate the \rightarrow capacitive current in relation to the \rightarrow faradaic current.

See also \rightarrow adsorptive stripping voltammetry, \rightarrow cathodic stripping voltammetry.

Refs.: [i] Fogg AG, Wang J (1999) *Pure Appl Chem* 71:891; [ii] Vydra F, Stulik K, Julakova E (1976) *Electrochemical stripping analysis*. Halsted Press, New York; [iii] Wang J (1985) *Stripping analysis*. VCH, Deerfield; [iv] Lovrić M (2002) *Stripping voltammetry*. In: Scholz F (ed) *Electroanalytical methods*. Springer, Berlin, pp 191–210

AMB

Anodization — Formation of a film on an electrode by means of an anodic (oxidation) process. Electrooxidation of silver in a chloride-containing solution results in the formation of an AgCl-film because the solubility product of AgCl is rapidly surpassed upon oxidation of silver. The AgCl-coated silver is suitable for preparation of a Ag/AgCl \rightarrow reference electrode. Formation of an oxide layer on other metals (e.g., in case of aluminum) may result in improved surface properties (corrosion resistance, hardness, optical properties).

RH

Anolyte \rightarrow electrolyte solution in the anodic compartment of an \rightarrow electrolysis cell or \rightarrow galvanic cell, i.e., in that part of the cell where the \rightarrow anode is placed.

FS

Anti-aliasing filter \rightarrow aliasing

Anti-Frenkel defects \rightarrow defects in solids

GI **Antimony electrode (or antimony-antimony oxide electrode)** \rightarrow pH-sensitive electrodes

Antipolar mass — Upon \rightarrow deep discharge of a \rightarrow NiCd-accumulator gas evolution might occur with associated problems of overpressure inside the cell. Because of production tolerances the actual capacity of cells might

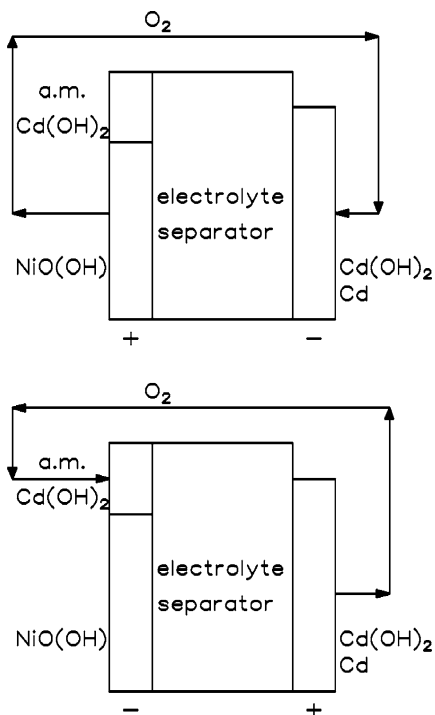

Antipolar mass — **Figure.** *Top:* Operation at overcharge; *bottom:* operation at deep discharge and polarity reversal, path of oxygen movement needed for pressure limitation indicated

vary, thus in series arrangement single cells might undergo polarity reversal even though other cells are still properly discharged. This problem can be avoided by adding antipolar mass to one electrode. Commonly an amount of $\text{Cd}(\text{OH})_2$ is added to the nickel electrode, the amount being large enough that upon complete oxidation of cadmium in the negative electrode still unreduced $\text{Cd}(\text{OH})_2$ is present in the positive nickel electrode. Thus hydrogen evolution is inhibited. If partial pressure of oxygen developed at the negative electrode by decomposition of water is large enough, oxygen will be reduced at the cadmium of the antipolar mass.

Ref.: [i] Linden D, Reddy TB (eds) (2002) *Handbook of batteries*. McGraw-Hill, New York

RH

Apparent equilibrium constants → *equilibrium constant*, and → *conditional equilibrium constants*

Apparent power → *power (electrical)*

Apparent rate constant → *activation energy*

Approach curve (SECM) — A current-distance curve recorded as an → *ultramicroelectrode* (tip) approaches a surface in → *scanning electrochemical microscopy*. On a surface where the reverse of the tip reaction occurs on the substrate surface the current increases as the distance between the tip and substrate, d , decreases (positive feedback). On an insulator surface the tip current decreases with decreasing d (negative feedback). The approach curve is useful in determining the absolute magnitude of d and can provide information about the heterogeneous electron transfer kinetics on the substrate and the rates of homogeneous reactions that occur in the gap between tip and substrate.

Ref.: [i] Bard AJ, Mirkin, MV (2001) *Scanning electrochemical microscopy*. Marcel Dekker, New York

AJB

Aprotic solvents → *solvents* that contain no acidic hydrogen, i.e., solvents that cannot donate → *protons*. This term usually refers to polar organic solvents that do not release protons easily due to chemical or electrochemical reaction. Common aprotic solvents include nitriles, e.g., acetonitrile, organic carbonates, e.g., propylene carbonate, ethers, e.g., tetrahydrofuran and others. In the broad sense, many inorganic solvents can be also classified as aprotic solvents, e.g. thionyl chloride and sulfonyl chloride. Organic solvents, such as alcohols and amines are classified as protic solvents, as they react spontaneously with active metals, yielding metal alcoholates and amides. Some organic solvents, such as ketones (with α hydrogen of very low acidity) represent intermediate cases, and can be regarded as aprotic or protic, depending on the studied system. Aprotic solvents are, in general, relatively chemically inert and possess a wide electrochemical window. See also → *nonaqueous solvents*.

Refs.: [i] Aurbach D, Weissman (1999) *Nonaqueous electrochemistry: an overview*. In: Aurbach D (ed) *Nonaqueous electrochemistry*. Marcel Dekker, New York, pp 1–52; [ii] Blomgren GE (1999) *Physical and chemical properties of nonaqueous electrolyte solutions*. In: Aurbach D (ed) *Nonaqueous electrochemistry*. Marcel Dekker, New York, pp 53–58; [iii] Izutsu K (2002) *Electrochemistry in nonaqueous solutions*. Wiley-VCH, Weinheim, pp 3–24; [iv] Lund H (2001) *Practical problems in electrolysis*. In: Lund H, Hammerich O (eds) *Organic electrochemistry*, 4th edn. Marcel Dekker, New York, pp 223–292; [v] Linden D (1994) *Handbook of batteries*, 2nd edn. McGraw-Hill, New York, Appendix A

YG, DA

Aquadag → *Acheson® graphite*

A Argentometric titration → precipitation titrimetry**Argument of impedance** → impedance

Arras cell — This was a chromic acid (carbon electrode)–zinc → battery used by the military in Arras (France).

See also → chromic acid battery, → Daniell cell, → zinc, → Zn^{2+}/Zn electrodes, → $Zn^{2+}/Zn(Hg)$ electrodes, → zinc–air batteries (cell), and → Leclanché cell.

Ref.: [i] Hauck WP (1883) *Die Galvanischen Batterien, Accumulatoren und Thermosäulen*, 2nd edn. Hartleben's Verlag, Wien

FS

Array electrodes — By replacing a single macroelectrode (an electrode with dimensions in the millimeter or centimeter range) by an array of → ultramicroelectrodes [i] or → nanoelectrodes [ii] the current density can be increased by orders of magnitude as well as the ratio of → faradaic to → capacitive currents. When array electrodes are employed as generator-collector systems with two distinct potentials applied, the diffusion distance between electrodes (w) becomes the main factor in controlling current densities. Interdigitated array electrodes are commonly employed in sensors or polymer coated electrode systems [iii] as well as in electrosynthesis [iv]. The short path between anode and cathode in microstructured arrays reduces the resistance (and therefore energy costs) and allows short lived intermediates to react at both electrodes (paired → electrosynthesis). See also → electrode geometry.

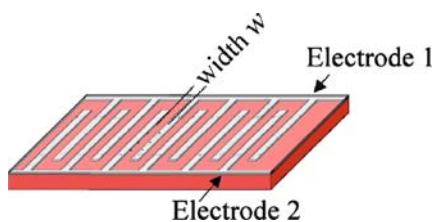

Array electrodes — Figure

Refs.: [i] Amatore C (1995) *Electrochemistry at ultramicroelectrodes*. In: Rubinstein I (ed) *Physical electrochemistry*. Marcel Dekker, New York, pp 131–208; [ii] Arrigan DWM (2004) *Analyst* 129:1157; [iii] Bard AJ (1994) *Integrated chemical systems*. Wiley, New York; [iv] Belmont C, Girault HH (1995) *Electrochim Acta* 40:2505

FM

Arrhenius, Svante August

(Courtesy of Michigan State University, Chemistry Department)

(Feb. 19, 1859, Wijk, Sweden – Oct. 2, 1927, Stockholm, Sweden). Arrhenius developed the theory of → dissociation of → electrolytes in solutions that was first formulated in his Ph.D. thesis in 1884: “Recherches sur la conductibilité galvanique des électrolytes” (Investigations on the galvanic conductivity of electrolytes). The novelty of this theory was based on the assumption that some molecules can be split into ions in aqueous solutions. The → conductivity of the electrolyte solutions was explained by their ionic composition. In an extension of his ionic theory of electrolytes, Arrhenius proposed definitions for acids and bases as compounds that generate hydrogen ions and hydroxyl ions upon dissociation, respectively (→ acid–base theories). For the theory of electrolytes Arrhenius was awarded the Nobel Prize for Chemistry in 1903 [i, ii]. He has popularized the theory of electrolyte dissociation with his textbook on electrochemistry [iv]. Arrhenius worked in the laboratories of → Boltzmann, L.E., → Kohlrausch, F.W.G., → Ostwald, F.W. [v]. See also → Arrhenius equation.

Refs.: [i] Snelders HAM (1970) *Arrhenius, Svante August*. In: Gillespie CC (ed) *Dictionary of scientific biography*, vol. 1. Charles Scribner's Sons, New York, pp 296–302; [ii] Jaffe B (1930) *Crucibles: The story of chemistry*. Simon and Schuster, New York, pp 219–241; [iii] Riesenfeld EH (1931) *Svante Arrhenius*. Akademische Verlagsgesellschaft, Leipzig; [iv] Arrhenius S (1901) *Lehrbuch der Elektrochemie*. Quandt & Händel, Leipzig; [v] Laidler KJ (1985) *Arch Hist Exact Sci* 32:43

EK

Arrhenius equation — The temperature-dependent form of the rate coefficient

$$k = A \exp(-E_a/RT)$$

is called the Arrhenius [i–iii] equation after → Arrhenius, who published a paper in 1889 demonstrating that a wide range of reactions have temperature dependencies that

conform to this equation [iv]. In this relationship k is the \rightarrow *rate coefficient*, A is the pre-exponential factor, E_a is the \rightarrow *activation energy*, R is the \rightarrow *gas constant*, and T is the \rightarrow *thermodynamic temperature*.

It should be mentioned that Arrhenius's paper [iv] was preceded by van't Hoff's book [v] (\rightarrow *Hoff, Jacobus Hendricus van't*), in which an equation compatible with that described above, was proposed on the basis of the relationships between equilibrium constants and the rate constants for the forward and reverse reactions. Nevertheless, the equation was named Arrhenius equation [vi–vii].

Refs.: [i] Mills I, Cvitas T, Homann K, Kallay N, Kuchitsu K (eds) (1993) *IUPAC quantities, units and symbols in physical chemistry*. Blackwell Scientific, Oxford, p 55; [ii] Pilling MJ, Seakins PW (1995) *Reaction kinetics*. Oxford University Press, Oxford, pp 19–21; [iii] Atkins PW (1993) *Physical chemistry*. Oxford University Press, Oxford, pp 877–879, 889; [iv] Arrhenius S (1889) *Z phys Chem* 4:226; [v] van't Hoff JH (1884) *Études de dynamique chimique*. Müller F, Amsterdam; [vi] Laidler KJ, King MC (1984) *J Chem Educ* 61:494; [vii] Logan SR (1982) *J Chem Educ* 59:279

GI

Association — The assembling of separate \rightarrow *molecular entities* into any aggregate, especially of oppositely charged free ions into \rightarrow *ion pairs* or larger and not necessarily well-defined clusters of ions held together by electrostatic attraction. The term signifies the reverse of \rightarrow *dissociation* but is not commonly used for the formation of definite \rightarrow *adducts* by colligation or \rightarrow *coordination*.

Ref.: [i] Muller P (1994) *Pure Appl Chem* 66:1077

WK

Association constant — Solvents having a low dielectric constant (e.g., benzene $\epsilon_r = 2.29$) cannot split protons from acids. The acid/base behavior in these solvents is based on association reactions between acidic and basic components in the solution according to:

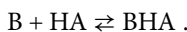

This usually involves formation of an ion pair BH^+A^- involving hydrogen bonds, formation of free ions is negligible. The association constant is thus defined:

$$K_{BHA} = a_{BHA} / (a_B a_{HA}) \approx c_{BHA} / (c_B c_{HA}) .$$

Dissociation of a salt in a solvent can similarly be treated taking into account ion pair formation. An ion association constant associated with the equilibrium established between ion pairs and dissociated ions is derived in the \rightarrow *Bjerrum* theory of ion pairs.

Ref.: [i] Bockris JO'M, Reddy AKN (2006) *Modern electrochemistry*. Springer, New York

RH

Astatic galvanometer \rightarrow *Galvanoscope* with two magnetic needles connected to each other with opposite polarity and only one of the needles is subjected to the metal coil through which a current flows. The two needles have zero net deflection in the magnetic field of the earth, and hence the measured deflection depends only on the magnitude of the current and is not affected by the magnetic field of the earth. The instrument was invented by \rightarrow *Kelvin*.

Ref.: <http://physics.kenyon.edu/EarlyApparatus/>

FS

Asymmetry potential — The glass membrane used in a \rightarrow *glass electrode* may be subject to differences in mechanical stress at the inner and the outer surface. In addition, the chemical composition of the silica framework may be different at the surfaces. Also the glass membrane is in contact with the interior buffer solution of well-defined and practically constant composition, whereas the outer solution may be different not only in pH-value (the quantity to be measured) but also in composition, ionic strength etc. These influences may cause an additional potential difference between the inner and the outer solution. This asymmetry potential can be measured by using exactly the same solution on both sides during the calibration procedure, most frequently the value is electronically compensated (by adding a suitable voltage to the measured voltage generated in the \rightarrow *glass electrode* using an \rightarrow *operational amplifier* circuit) assuming that the mentioned factors do not change significantly in a set of measurements. Asymmetry potentials can occur at any \rightarrow *membrane-based* \rightarrow *ion selective electrode*. See also \rightarrow *potential*.

RH

Atomic filter \rightarrow *analog filter*

Atomic layer epitaxy (electrochemical) — Electrochemical atomic layer epitaxy (ECALE) is a self-limiting process for the formation of structurally well-ordered thin film materials. It was introduced by Stickney and coworkers [i] for the layer by layer growth of compound semiconductors (CdTe, etc.). Thin layers of compound semiconductors can be formed by alternating \rightarrow *underpotential deposition* steps of the individual elements. The total number of steps determines the final thickness of the layer. Compared to flux-limited techniques

A

ECALE works close to equilibrium conditions. Because one deposition step involves the formation of just one monolayer (or fractions of it) there are no mass transport limitations and the formation of three-dimensional structures (e.g., “cauliflower”) does not occur. The drawback is the relatively low deposition rate and the need to switch between two or more electrolytes continuously.

Ref.: [i] Gregory BW, Suggs DW, Stickney JL (1991) *J Electrochem Soc* 138:1279

AB

Auger electron spectroscopy (AES) → *surface analytical methods*

Aurvillius series → *BIMEVOX*

Autoprotolysis — is a proton transfer reaction between two identical molecules (usually a solvent), one acting as a Brønsted acid and the other as a Brønsted base (→ *acid–base theory*). An example is the well-known autoprotolysis of water:

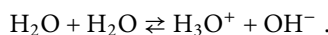

The equilibrium can be described with the autoprotolysis constant, i.e., the product of the activities of the species produced as a result of autoprotolysis. For solvents in which no other ionization processes are significant the term is synonymous with “ionic product”.

Refs.: [i] McNaught AD, Wilkinson A (1997) *IUPAC compendium of chemical terminology*, 2nd edn. Blackwell Science, Oxford

HK

Autoprotolysis constant — The → *ion-product* calculated from the ion activities of the conjugate acidic and basic species of an → *amphiprotic solvent* (SH). The chemical equation of such self-ionization reactions can be schematized as: $2\text{HS} \rightleftharpoons \text{H}_2\text{S}^+ + \text{S}^-$, where H_2S^+ is the conjugate cation, S^- the conjugate anion. The autoprotolysis constant can be formulated as: $K_{\text{auto}} = [\text{H}_2\text{S}^+] \cdot [\text{S}^-]$, [i].

Ref.: [i] Reichardt C (2004) *Solvents and solvent effects in organic chemistry*. Wiley-VCH, Weinheim

FG

Auxiliary (counter) electrode — In an → *electrolysis cell* (including all 2- and 3-electrode voltammetric cells) a current flows through the → *working electrode* and the counter electrode (or **auxiliary** electrode because it serves to allow the proceeding of the processes at the working electrode). It is made of a conducting and usually inert material, and should be kept at a sufficiently long distance or be separated from the working electrode (with, e.g., a sintered glass disk) to exclude the possibility of reaching the working electrode surface by the substances produced at its surface. If during the electrolysis process the working electrode becomes the cathode or the anode it will be turned into the anode and the cathode, respectively. The real surface area of the auxiliary electrode (→ *electrode surface area*) should be larger than that of the working electrode. This is of special importance in case of 2-electrode cells → *voltammetry* and → *impedance spectroscopy*.

Refs.: [i] Stojek Z (2002) *Experimental setup*. In: Scholz F (ed) *Electroanalytical methods*. Springer, Berlin; [ii] <http://www.bioanalytical.com/products/ec/auxele.html>

ZS

B

Bacon, Francis Thomas



(Dec. 21, 1904, Billericay, Essex, UK – May 24, 1992, Little Shelford, near Cambridge, UK) Bacon was educated at Eton College specializing in science and at the Trinity College in Cambridge obtaining a degree in mechanical sciences. He started to work on the hydrogen–oxygen fuel cell in 1932. He constructed the first practical and efficient → *fuel cells*. He used potassium hydroxide instead of acids which was less corrosive to the electrodes; therefore, platinum could be replaced by inexpensive nickel electrodes. The development of the porous → *gas-diffusion electrodes* of high surface area was the other important step. Beside everyday applications such as transport, the most notable success was that Bacon cells provided electrical power for the functioning of systems and the production of drinking water in the manned moon flights of the Apollo space program.

Francis Thomas Bacon was a direct descendant of Sir Francis Bacon (1561–1626). Among others he was elected a fellow of the Royal Society (1973), and awarded the first Grove Medal (1991) [ii].

Refs.: [i] <http://chem.ch.huji.ac.il/~eugenik/history/bacon.html>; [ii] Bacon FT (1979) *J Electrochem Soc* 126:7C

Bacon cell — Hydrogen–oxygen fuel cell initially developed by → *Bacon*. → *gas-diffusion electrodes* were prepared from carbonyl nickel by pressing and subsequent sintering. The three-phase boundary was fixed inside the porous electrode body by preparing the electrode as a bilayer structure. The “working layer” with pores of about 10–30 μm diameter is covered on the electrolyte solution side by a thin layer with an average pore diameter of 1.5 μm. Pressure of the feed gas needed for operation is adjusted to a value at which the large pores are kept

filled with gas whereas the small pores are left filled with electrolyte solution by capillary action, bubbling of reactant gas is thus avoided. Because of the poor electrocatalytic activity of nickel and the limited actual (true) surface area the operation temperature had to be elevated to about 200 °C. Vapor pressure of the alkaline electrolyte solution (37–50% KOH) required operation pressures of 20–40 atm. Corrosion of the oxygen-consuming nickel electrode enhanced at these temperatures was limited by preoxidation of the porous cathode body. By oxidizing treatment of the electrode in lithium-containing caustic solution a doped semi-conducting nickel oxide is formed showing improved corrosion resistance. Cell voltages of 0.9 V at current densities of 300 mA cm⁻² were achieved.

Ref.: [i] Kordes G, Simader G (1996) *Fuel cells and their applications*. VCH, Weinheim

RH

Background current — (i) Generally, in electrochemical systems, any current other than the wanted one (e.g., see → *dark current* in photovoltaics).

(ii) In → *voltammetry* any current that is not due to the analyte. At high → *potentials* the working window of the → *indicator electrode* is limited by the → *oxidation* of → *electrode material*, or → *anions* of the → *supporting electrolyte*, or the → *solvent*, and at low potentials it is limited by the → *reduction* of → *hydrogen ions*, or → *cations* of the supporting electrolyte, or the solvent, or the electrode material (e.g., → *mercury* in the presence of ammonium salts in → *non-aqueous media*). Within the window, a → *residual current* consists of → *capacitive* and → *faradaic* components. A → *double layer* charging current can not be avoided, but its influence can be diminished by the current sampling procedure in → *pulse voltammetric* techniques. Generally, the capacitive current is proportional to the rate of changing the → *electrode potential* (E), → *capacitance* (C) and → *surface area* (S):
$$I = \left[CS + S(E - E_{\sigma=0}) \frac{dC}{dE} \right] \frac{dE}{dt} + C(E - E_{\sigma=0}) \frac{dS}{dt}$$
 The first term limits the range of scan rates that can be applied in → *cyclic voltammetry* on stationary electrodes ($dS/dt = 0$), while the second term is important only in DC → *polarography* with → *dropping mercury electrode*. However, care must be taken to avoid a leakage of solution into any gap between the active electrode disk and the insulating sheath, a porosity of electrode surface, and the formation of a thin film of the solution surrounding the lower end of the mercury thread within the tip of the capillary. In all these cases a fluctuating surface area may cause the fluctuation of capacitive current. In pulse voltammetry, the decay of charging current associated

GI

B

with these imperfections is slower than the decay of capacitive current of the electrode surface [i, ii].

Faradaic components of the background current are caused by the reduction of \rightarrow oxygen or other impurities in the supporting electrolyte, and by the formation of oxide layers on metal electrodes. The concentration of oxygen in well-aerated electrolyte is about 0.1 mM. Oxygen is reduced at noncatalytic electrodes in two separate two-electron steps at potentials that vary between 0.05 V and -0.9 V vs. SCE, depending on pH and on electrode material. For the majority of measurements, oxygen must be removed from the solution. In the laboratory, solutions are saturated with nitrogen or argon to reduce the partial pressure of oxygen to a very low value. Ultrapure gases should always be preferred. However, there is a chance to contaminate solutions with oxygen due to the permeability of most plastic tubes used to propel nitrogen or argon. In extreme cases full glass apparatus has to be used. Oxygen adsorbed on particles of \rightarrow graphite powder must be removed by heating the powder in nitrogen prior to the preparation the \rightarrow carbon paste electrode. Otherwise the response may appear noisy. In \rightarrow anodic stripping voltammetry the purity of mercury is very important. It must be ensured that no traces of investigated element are present in mercury prior to the accumulation. The supporting electrolyte should be prepared by using ultrapure chemicals. Finally, the \rightarrow cell response may appear noisy due to poor electrical contacts and faults in the interconnecting cables. The noise can be reduced by placing the cell in a \rightarrow Faraday cage.

(iii) In \rightarrow electrolysis, \rightarrow coulometry, \rightarrow electrogravimetry, \rightarrow electrosynthesis and \rightarrow batteries, the term background current is also used for currents that are not caused by the main process.

Refs.: [i] Brett CMA, Oliveira Brett AM (1998) *Electrochemistry*. Oxford University Press, Oxford; [ii] Pelzer J, Scholz F, Henrion G, Nitschke L (1989) *Electroanalysis* 1:437

Back-titration — A process for quantitative analysis in which an excess of \rightarrow titrant is added to the \rightarrow titrand and then a second titrant is used to determine the excess amount. This process is often required when the rate of reaction between the \rightarrow analyte and titrant is slow or when the \rightarrow standard solution lacks stability [i].

Ref.: [i] Mendham J, Denney R, Barnes J, Thomas M, Denney R (2000) *Vogel's quantitative chemical analysis*. Prentice Hall, New Jersey

Bacterial corrosion \rightarrow biocorrosion

Baghdad battery — A number of artifacts consisting of ca. 130 mm long clay jars containing a copper cylinder made of a rolled-up copper sheet, capped at the bottom, in turn covering and protecting an iron rod were discovered by Leroy Waterman in the village of Khuyut Rabua (Tel Omar) near Baghdad, Iraq in 1936. Wilhelm König, the German director of the National Museum of Iraq published a paper speculating that they may have been \rightarrow galvanic cells, perhaps used for \rightarrow electroplating gold onto silver objects. König thought the objects might be Parthian (between 250 BC and 224 AD). However, the style of the pottery is Sassanian (224–640 AD) which means that they are more recent than König thought. Although there is still a controversy regarding the real purpose of these artifacts, they could be or could have been used to generate electricity since the iron rods are isolated from the copper by asphalt plugs, and if the jars were filled with a liquid, e.g., with vinegar which was known also in ancient time, this surrounds the iron rod as well, therefore it is, in fact, a copper-iron battery. When filled with vinegar, the jar produces about 1.1 Volts.

Refs.: [i] Dunsch L (1985) *Geschichte der Elektrochemie*. VEB Deutscher Verlag für Grundstoffindustrie, Leipzig, pp 9–10; [ii] MacKechnie JC (1960) *J Inst Electrical Eng* 6:356; [iii] Dubpernell G (1978) *Evidence of the use of primitive batteries in antiquity*. In: *Selected topics in the history of electrochemistry*. The Electrochemical Soc, Princeton, I-22

GI

Baizer–Monsanto process — (also called *Monsanto process*) is the reductive electrohydrodimerization of acrylonitrile, ACN, to adipodinitrile, ADN, an intermediate in the manufacture of Nylon 66TM:

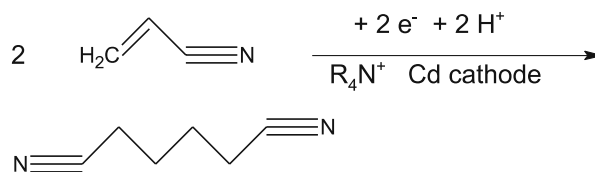

ŠKL

FG

The principle has been known since the 1940s, but it was M.M. Baizer who initiated in 1959 the use of quaternary ammonium salts such as tetraethylammonium *p*-toluenesulfonate in this reaction, leading to mass yields of 90% ADN. Together with Monsanto he commercialized and improved the process ever since. First used process setups consisted of divided cell reactors with \rightarrow catholytes of an aqueous solution of ACN and ADN in 40% tetraethylammonium ethyl sulfate, an \rightarrow anolyte of diluted sulfuric acid, separated

by an ion exchange membrane, and lead electrodes (anode with 1% silver).

Soon after, the presently used undivided cell (see Fig.) was developed to overcome the shortcomings of the former, especially the high energy costs. The cadmium cathodes and steel anodes are kept at a 2 to 3 mm distance by plastic spacers in a pressure vessel. The aqueous sodium phosphate electrolyte containing hexamethylene bis(ethyltributyl)ammonium phosphate (0.4%) and emulsified acrylonitrile is pumped continuously through the cells with ca. 1 m s^{-1} and at ca. 55°C . The electrochemical process parameters are: cell voltage: 3.83 V, current density: 2.0 kA m^{-2} , power consumption: 2.43 kWh kg^{-1} . The crude ADN is passed through a multi-column distillation system, where the pure product is separated from by-products and ACN, which is returned to the process. The adipodinitrile purity must be over 90% to serve as initial product for the hydrogenation into hexamethylenediamine. Crucial points of the described process setup are a limited life span of the electrodes of only 2 to 3 months, and the thereby caused discontinuity of the process, as well as special safety considerations resulting from oxygen and (by-product) hydrogen together with other volatile organics in one single gas phase. Nowadays [iii] production capacities of the B.-M. process are (in tons per year): Solutia (Dakatur, AL, USA): 181,000; BASF (Seal Sands, UK): 91,000; Asahi Chemical (Nobeoka, Japan): 37,000.

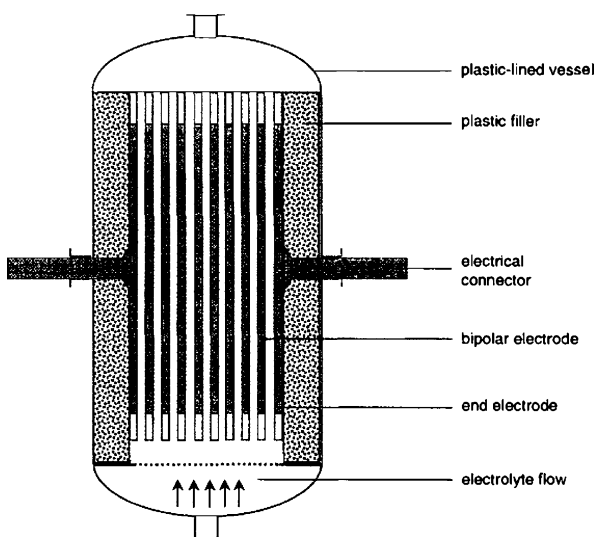

Baizer-Monsanto process — Figure

Refs.: [i] Baizer MM (1964) *J Electrochem Soc* 111:215; [ii] Baizer MM, Danly DE (1979) *Chem Ind (London)* 435:439; [iii] Pütter H (2001) *Industrial electroorganic chemistry*. In: Lund H, Hammerich O (eds) *Organic electrochemistry*. Marcel Dekker, New York, pp 1259–1307; [iv] Pletcher D, Walsh FC (1990) *Industrial electrochemistry*. Chapman & Hall, London, p 298

MHer

Balbach-Thum cell — Electrolytic cell for silver refining (\rightarrow *electrorefining*). On the bottom of the cell (about $250\text{--}300 \text{ dm}^3$ volume) a silver plate is placed as cathode. The anode made of raw silver is placed in a basket in a cloth bag. A solution of silver nitrate is employed. Dissolved silver ions are deposited as a dendritic mass on the cathode, metal ions less noble than silver stay in solution, whereas more noble metals are kept as anode sludge in the cloth bag. This cell is frequently employed in the USA, the \rightarrow *Möbius cell* is used in Europe. As compared to the Möbius cell the anodes are consumed completely, only a single-piece cloth is needed, and no moving mechanical parts are involved. As drawbacks the large floor space of the cell, the low current density, the large cell voltage because of the large interelectrode distance, the need for manual scraping of the cathode on the bottom of the cell, and the large solution inventory may be considered.

Refs.: [i] Zirngiebl E (1993) *Einführung in die Angewandte Elektrochemie*. Salle & Sauerländer, Frankfurt; [ii] Pletcher D, Walsh FC (1993) *Industrial electrochemistry*. Blackie Academic & Professional, London

RH

Band bending — “Band bending” is an example of laboratory jargon, and refers to the occurrence of internal electric fields inside \rightarrow *semiconductor* materials, howsoever caused. The origin of the term is as follows. A common way to visualize energy states inside semiconductors is to draw the positions of both band edges (the valence band edge and the conduction band edge) on an “energy band diagram” (a plot of energy versus distance). When an internal electric field exists inside the semiconductor material, the band edges appear curved on this plot, thus leading to the name “band bending”. Experimentally, band bending arises in two ways. At thermodynamic equilibrium, band bending manifests spontaneously at the interface between two semiconductors, or at the interface between a semiconductor and a metal, if the \rightarrow *electron work function* of each phase is different. Away from thermodynamic \rightarrow *equilibrium*, band bending can be increased or decreased by applying an electric potential difference of appropriate sign and magni-

tude between the two phases. See also → *flat-band potential*.

Band gap → *semiconductor*

Band-pass filter → *signal filtering*

Band-stop filter → *signal filtering*

Bardeen–Cooper–Schrieffer theory → *BCS theory*

Barker, Geoffrey Cecil



(Reprinted from J. Electroanal Chem. 75 (1977) 1, Copyright (1977), with permission from Elsevier)

(Oct. 2, 1915, Belper, Derbyshire, UK – Mar. 31, 2000, Oxford, UK) invented in 1952 → *square-wave polarography* [i], in 1958 → *pulse polarography* [ii, iii], and → *radio frequency polarography* [iv] applying for the first time → *faradaic rectification*. Beside these techniques, Barker developed several other variants of polarography and he is the father of modern photoemission studies at electrodes [v, vi]. During World War II Barker took part in the radar development in the UK. The thorough learning of electronics during that period was certainly the basis for his great achievements in developing electrochemical measuring techniques.

Refs.: [i] Barker GC, Jenkins IL (1952) *Analyst* 77:685; [ii] Barker GC, Gardner AW (1958) *At Energy Res Establ, Harwell, C/R* 2297; [iii] Barker GC, Gardner AW (1960) *Fresenius Z Anal Chem* 173:79; [iv] Barker GC (1958) *Anal Chim Acta* 18:118; [v] Barker GC (1977) *J Electroanal Chem* 75:1; [vi] Parsons R (2000) *J Electroanal Chem* 494:77

SF

potential pulses is applied during a period where the DC potential changes only by a negligible increment (for a linear DC ramp) or not at all (for a staircase ramp).

Refs.: [i] Barker GC, Jenkins IL (1952) *Analyst* 77:685; [ii] Bond AM (1980) *Modern polarographic methods in analytical chemistry*. Marcel Dekker, pp 391–399; [iii] Lovrić M (2002) In: Scholz F (ed) *Electroanalytical methods*. Springer, Berlin, pp 111–136; [iv] Mirčeski V, Komorsky-Lovrić Š, Lovrić M (2007) *Square-wave voltammetry*. In: Scholz F (ed) *Monographs in Electrochemistry*. Springer, Berlin

FS

Barrier oxide film — When the surface of a metal is anodically oxidized, a dense oxide film may grow that protects the metal underneath. Such barrier films are important for → *corrosion protection* and also for fabricating → *capacitors*.

Ref.: [i] Marcus P, Maurice V (2000) *Passivity of metals and alloys*. In: Schütze M (ed) *Corrosion and environmental degradation, vol. 1*. Wiley-VCH, Weinheim, pp 131

FS

Barrierless process — is a → *charge transfer reaction* occurring under small deviation from equilibrium (for example at low → *overpotential*) in the absence of an activation barrier, and with a → *transfer coefficient* equal to unity. In terms of the reaction energy profile, this situation corresponds to the term of products intersecting the term of reactants in its minimum. The → *activation energy* becomes equal to reaction → *free energy*. Simultaneously, the reverse reaction appears to be an → *activationless process*. The problem was addressed systematically by Krishtalik et al. starting from 1960 (see original refs. in [i, ii]). In the framework of the slow discharge theory of → *Frumkin* (see there → *Frumkin's slow discharge theory*), the kinetics of a b.p. is expected to be independent on solution composition, with a Tafel slope (→ *Tafel equation*) equal to $2.3RT/F$. The cathodic barrierless p. can be experimentally observed when one starts at potentials more negative than the → *equilibrium potential*, not being screened by a reverse anodic process. The features of the barrierless p. were observed experimentally for → *hydrogen evolution* on mercury in acidic aqueous and ethylene glycol solutions containing certain strongly adsorbing ions, as well as in concentrated solutions of some acids. The observation of barrierless processes opens up possibilities to obtain the latent heat of the electrode process, the true activation energy, and the temperature derivative of the → *Galvani potential*. Similar behavior was found for → *hydrogen evolution* on Ag and chlorine evolution on graphite. Studies of b.p. stimulated an active development in understanding isotope ef-

FS

Barker square-wave voltammetry — The protocol of → *square-wave voltammetry* developed by → *Barker* is based on a square wave potential train with a frequency that is high compared to the scan rate of the DC potential, i.e., a multiple number of positive and negative

fects [iii, iv] and high temperature electrochemical techniques for aqueous solutions [iv], as well as the analysis of the preexponential factor in terms of \rightarrow proton transfer theory.

Refs.: [i] Krishtalik LI (1968) *Electrochim Acta* 13:1045; [ii] Krishtalik LI (2002) *Electrochim Acta* 48:181; [iii] Krishtalik LI, Tsionsky VM (1971) *J Electroanal Chem* 31:363; [iv] Tsionskii VM, Kriksunov LB, Krishtalik LI (1991) *Electrochim Acta* 36:411

GT, OP

Batteries — Power sources that produce \rightarrow direct current (DC) by converting chemical energy into electrical energy. These power sources employ spontaneous electrochemical reactions as the source of the electrical energy by forcing the electrons to flow from a reductant (anode) to the oxidant (cathode) externally, through the consumer. Each single battery cell contains a negative electrode (\rightarrow anode) that contains a reducing material in which an oxidation process takes place upon discharge, a positive electrode (\rightarrow cathode) containing an oxidizing material in which an oxidation process takes place upon discharge, and an electrolyte system (liquid, gel, or solid). Batteries can include several electrochemical cells interconnected in series or in parallel to provide the required potential and current levels. The main parameters that define battery performance are (i) \rightarrow voltage, (ii) electrical \rightarrow energy, (iii) electrical \rightarrow power. The battery voltage depends on the electrode chemistry and on the number of cells in the stack. The overall electrical energy is usually expressed in watt-hours (Wh) and is calculated as the product of capacity and voltage: $E = UI t$ (U in volt, I in ampere, and t in hours). The electrical power is the rate at which a battery can deliver electrical energy. The rate is expressed in watts (W) and calculated as the product of current and voltage: $P = UI$ (U in volt and I in ampere). There are two significant types of batteries, primary and secondary. **Primary batteries** are not designed to be recharged. **Secondary batteries** are designed for repetitive use, and thus can be charged and discharged periodically. Batteries can be classified in different ways: primary vs. rechargeable, aqueous vs. nonaqueous, solid electrolyte vs. liquid electrolyte solution, stationary vs. flow, and ambient temperature vs. high temperature. The most important batteries are Zn–MnO₂ (primary) (\rightarrow alkaline batteries), Li–MnO₂ and Li–SOCl₂ (primary), Pb/H₂SO₄/PbO₂ (\rightarrow lead-acid battery), Cd–NiOOH (Ni–Cd, secondary), Metal-hydride-based batteries like Ni–Metal–Hydride (NiMH, secondary) and secondary \rightarrow lithium batteries (most common Li-graphite (Li_xC₆) vs. Li_{1-x}CoO₂, $0 < x < 1$). The field of batteries is very dynamic, and extensive ef-

forts are devoted throughout the world to R&D of new battery systems and the improvement of existing systems.

Refs.: [i] Linden D (1994) *Handbook of batteries*, 2nd edn. McGraw-Hill, New York; [ii] Crompton TR (2000) *Battery reference book*, 3rd edn. Newness, Oxford; [iii] Dell RM, Rand DAJ (2001) *Understanding batteries*. Royal Society of Chemistry

OC, DA

Baudet cell — This was a \rightarrow chromic acid battery with zinc anodes, and a construction that the chromic acid solutions could be delivered from vessels containing solid potassium dichromate and sulfuric acid.

See also \rightarrow Daniell cell, \rightarrow zinc, \rightarrow Zn²⁺/Zn electrodes, \rightarrow Zn²⁺/Zn(Hg) electrodes, \rightarrow zinc-air batteries (cell), and \rightarrow Leclanché cell.

Ref.: [i] Hauck WP (1883) *Die Galvanischen Batterien, Accumulatoren und Thermosäulen*, 2nd edn. Hartleben's Verlag, Wien

FS

BCS theory — (Bardeen–Cooper–Schrieffer theory) describes the nature of superconductivity and other properties of the so-called Type I superconductors, a group of 30 pure metals such as Al, In, Sn, Hg, V, Pb, etc. These exhibit zero electrical resistivity below a certain “critical” temperature, zero internal magnetic field, and a critical magnetic field leading to the disappearance of superconductivity. The critical magnetic fields in the Type I superconductors are very low, limiting possible applications. A better stability with respect to temperature and magnetic field is characteristic of the so-called Type II superconductors, usually alloys such as Nb₃(AlGe).

One conceptual element of the BCS theory is the formation of \rightarrow Cooper pairs, namely pairing of \rightarrow electrons close to the \rightarrow Fermi level due to a slight attraction resulting from phonon interaction with the crystal lattice. These pairs of electrons act like bosons which can condense into the same energy level. An energy band gap is to be left above these electrons on the order of 10⁻³ eV, thus inhibiting collision interactions responsible for the ordinary \rightarrow resistance. As a result, zero electrical resistivity is observed at low temperatures when the thermal energy is lower than the band gap. The founders of the BCS theory, J. Bardeen, L. Cooper, and R. Schrieffer, were awarded by the Nobel Prize in 1972.

See also: \rightarrow semiconductor, \rightarrow conductor, \rightarrow Ohm's law, \rightarrow conductance, \rightarrow conduction band.

Refs.: [i] Rohlf JW (1994) *Modern physics from α to Ω* . Wiley, New York; [ii] Cyrot M, Pavuna D (1992) *Introduction to superconductivity and high-T_c materials*. World Scientific, London

VK

B

Beam deflection — A deviation of the light beam wavefront when it passes from one medium to another with a different \rightarrow refractive index, or through a medium with an inhomogeneous refractive index. The wavefront velocity is ($v = c/n$) and the wavelength (λ) is related to n by $\lambda = v/f$, where c is the velocity of light in a vacuum, n is the refractive index of the medium and f is the beam frequency. Thus, the wavelength of a laser beam wavefront will increase when the refractive index of the electrolyte decreases [i]. See also \rightarrow refraction or \rightarrow mirage effect.

Refs.: [i] Rosolen JM, Decker F, Fracastoro-Decker M, Gorenstein A, Torresi RM, Cordoba Torresi SI (1993) *J Electroanal Chem* 354:273; [iii] Garay F, Barbero CA (2006) *Anal Chem* 78:6740

FG

Beating mercury heart — Under certain conditions a drop of mercury pulsates in a rhythmic fashion, resembling a beating heart [i–iv]. It is a demonstration of periodic behavior in electrochemical systems (see \rightarrow electrochemical oscillations).

The following procedure has to be applied:

- Place a drop of pure mercury in a watch glass.
- Cover it with $6 \text{ mol dm}^{-3} \text{ H}_2\text{SO}_4$ solution.
- Add $1\text{--}2 \text{ cm}^3 0.1 \text{ mol dm}^{-3} \text{ K}_2\text{Cr}_2\text{O}_7$ solution.
- Put a steel needle which just touches the Hg drop.
- Add $0.5\text{--}2 \text{ cm}^3 18 \text{ mol dm}^{-3} \text{ H}_2\text{SO}_4$ solution until the Hg drop starts to pulsate.

During the pulsation the mercury drop will change its shape. A periodic variation between round and triangle shapes can be seen.

The phenomenon can be explained as follows.

The \rightarrow surface tension (γ) of the mercury (see \rightarrow electrocapillary curves) is a function of the potential (i.e., the \rightarrow surface charge, σ). When $\sigma = 0$ γ has a maximum value, consequently the mercury drop will take a spherical or round shape. When $|\sigma| > 0$ γ decreases, and the drop tends to flatten.



Solution of $\text{K}_2\text{Cr}_2\text{O}_7$ and H_2SO_4

Beating mercury heart — Figure. The experimental arrangement

At the two different metals the following reactions take place [ii]:

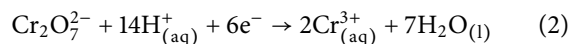
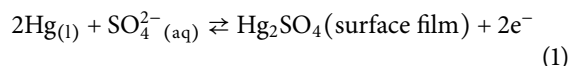

At the iron surface an oxide-hydrate layer may develop.

$\text{Hg}|\text{Hg}_2\text{SO}_4$ is the positive electrode (with excess positive charge on its surface), iron is the negative electrode in the \rightarrow galvanic cell formed. When the iron nail contacts the mercury, as a consequence of the variation of the shape of the Hg drop, the cell will be short-circuited. Therefore, the electrons transferred from the iron to the $\text{Hg}|\text{Hg}_2\text{SO}_4$ electrode reduce the surface Hg_2SO_4 film back to metallic mercury. The surface tension increases again and the drop becomes rounder and it will lose the direct contact with the iron nail, i.e., the short-circuiting will be interrupted. Then, the whole process starts again.

Refs.: [i] Summerlin LR, Ealy JL Jr (1985) *Chemical demonstrations. American Chem Soc, Washington*, pp 93–94; [ii] Marques MI, Zhao Y, Garcia N (1997) *J Phys Chem B* 101:2333; [iii] Smolin S, Imbihl R (1996) *J Phys Chem* 100:19055; [iv] Keizer J, Rock PA, Lin SW (1979) *J Am Chem Soc* 101:5637

GI

Beckman, Arnold Orville — (April 10, 1900, Cullom, Illinois, USA – May 18, 2004, La Jolla, California, USA) Earned his B.Sc. and M.Sc. degrees from the University of Illinois. Received a Ph.D. from the California Institute of Technology in 1928. He founded what eventually became Beckman Instruments in 1935 with the invention of the acidimeter which was later called a \rightarrow pH meter. Beckman developed also the UV-VIS (1940) and IR spectrophotometers (1942) and the Helipot (helical potentiometer) (1940) as well as a dosimeter (1942).

Refs.: [i] <http://www.chemheritage.org/explore/Beckman/chptr1-9.htm>; [ii] http://www.beckman.com/hr/memorial/mem_news.asp; [iii] Inzelt G (2005) *J Solid State Electrochem* 9:181

GI

Behrend, Anton Friedrich Robert



(Dec. 17, 1856, Harburg, Germany – Sep. 15, 1926, Hannover, Germany) Ph.D. in organic chemistry, Leipzig 1881. In 1893, Behrend performed the first \rightarrow *potentiometric titration* (precipitation) in the laboratory of \rightarrow *Ostwald, F.W.* in Leipzig, Germany. He titrated a mercury(I) nitrate solution with chloride, bromide, and iodide ions [i] using a mercury electrode as \rightarrow *indicator electrode*. From 1894 to 1924 he was Professor of organic and physical chemistry in Hannover. Behrend is also well-known for the so-called Behrend rearrangement in organic chemistry [ii].

Refs.: [i] Behrend R (1893) *Z phys Chem* 11:466; [ii] Stock JT (1992) *J Chem Educ* 69:197

Becquerel, Antoine César



(© Collections Ecole Polytechnique)

(Mar. 8, 1788, Châtillon-sur-Loing, France – Jan. 18, 1878, Paris, France) French scientist, professor of physics at the Museum of Natural History (Paris), developed the “Constant Current Cell”, but received recognition for this cell only in France whereas elsewhere the almost identical cell is called \rightarrow *Daniell cell* (\rightarrow *Daniell*). Becquerel helped in validating \rightarrow *Faraday’s law*, extensively studied metal deposition in particular in metallurgy and

surface finishing. He published more than 500 papers including studies on the electrocapillary effect and a textbook on electrochemistry in 1843.

Refs.: [i] Magnusson M (ed) (1990) *Chambers biographical dictionary*. W&R Chambers, Edinburgh; [ii] Crystal D (ed) (1998) *The Cambridge biographical encyclopedia*. Cambridge University Press, Cambridge; [iii] Becquerel AC (1843) *Éléments d’électro-chimie*. Paris (German translation: Becquerel AC (1848) *Elemente der Electro-Chemie*, 2nd edn. Otto, Erfurt)

RH

Bending beam method — The principles of the “bending beam” (“bending cantilever”, “laser beam deflection”, “wafer curvature”) method were first stated by Stoney [i], who derived an equation relating the stress in the film to the radius of curvature of the beam. The bending beam method can be effectively used in electrochemical experiments, since the changes of the \rightarrow *surface stress* (Δg) for a thin metal film on one side of an insulator (e.g. glass) strip (or a metal plate, one side of which is coated with an insulator layer) in contact with an electrolyte solution (\rightarrow *electrode*) can be estimated from the changes of the radius of curvature of the strip. If the \rightarrow *electrode potential* changes, electrochemical processes resulting in the change of g can take place exclusively on the metal side of the sample. The change in g induces a bending moment and the strip bends. In case of a thin metal film on a substrate if the thickness of the film t_f is sufficiently smaller than the thickness of the plate, $t_s \gg t_f$, the change of g can be obtained by an expression based on a generalized form of Stoney’s equation

$$\Delta g = k_i \Delta (1/R) , \quad (1)$$

where k_i depends on the design of the electrode [ii]. In most cases

$$k_i = E_s t_s^2 / 6(1 - \nu_s) , \quad (2)$$

where E_s , ν_s , and R are Young’s modulus, Poisson’s ratio and radius of curvature of the plate, respectively.

The derivation of Eq. (1) implies the assumption that $\Delta g = t_f \Delta \sigma_f$, where $\Delta \sigma_f$ is the change of the film stress. (In principle, if there are both plastic and elastic contributions to the total strain, the “generalized surface parameter” (γ^s) [iii] can be determined (\rightarrow *interfacial tension*)).

According to Eq. (1), for the calculation of Δg the changes of the reciprocal radius $\Delta (1/R)$ of curvature of the plate must be known. The values of $\Delta (1/R) = \Delta g / k_i$ can be calculated, if the changes $\Delta \theta$ of the deflection angle θ of a laser beam mirrored by the metal layer on the

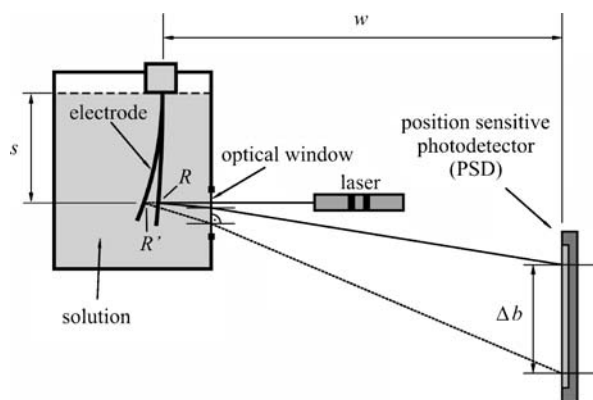

Bending beam method — Figure. Scheme of the electrochemical (optical) bending beam setup

plate are measured using an appropriate experimental setup as shown in Fig. 1 [iv]. The deflection can be determined also with other methods, e.g., with a *scanning tunneling microscope* [v–vi]. For the geometry shown the following approximate equation can be derived for large R and s , and small θ :

$$\Delta\left(\frac{1}{R}\right) \approx \frac{\Delta\theta}{2n_{s,i}s} \approx \frac{\Delta b}{2n_{s,i}sw}, \quad (3)$$

where s is the distance between the level of the solution in the cell (practically the lower end of the electrode holder) and the reflection point of the laser beam on the glass plate covered by a thin metal layer; w is the distance between the electrode and the position sensitive photo detector (PSD) and Δb is the change of the position of the light spot on the PSD. (Equation (3) is a good approximation only if the distance of the electrode from the optical window can be neglected compared to that of the PSD.) Since the laser beam is reflected inside the solution as shown in Fig. 1, and the deflection is measured outside the cell (in the air), the refractive index $n_{s,i}$ of the solution also must be taken into account [vii–viii]. Consequently, from Eqs. (1) and (3) at small deflections one obtains with good approximation the relation

$$\Delta g \approx \frac{k_i \Delta b}{2n_{s,i}sw}. \quad (4)$$

If the actual values of k_i (or t_s , E_s , ν_s), w , s , and $n_{s,i}$ are known, for the calculation of Δg only the experimental determination of Δb is necessary.

Refs.: [i] Stoney GG (1909) *Proc R Soc London* A32:172; [ii] Morcos I (1978) *Specialist periodical reports electrochemistry*, vol. 6. In: Thirsk HR (ed) *The Chemical Society*. Burlington House, London,

pp 65–97; [iii] Trasatti S, Parsons R (1986) *Interphases in systems of conducting phases*, *Pure & Appl Chem* 58:437; [iv] Láng GG, Ueno K, Ujvári M, Seo M (2000) *J Phys Chem B*104:2785; [v] Ibach H, Bach CE, Giesen M, Grossmann A (1997) *Surf Sci* 375:107; [vi] Haiss W (2001) *Rep Prog Phys* 64:591; [vii] Láng GG, Seo M (2000) *J Electroanal Chem* 490:98; [viii] Rokob TA, Láng GG (2005) *Electrochim Acta* 51:93

GGL

Berl reaction → electroreduction reaction of dioxygen (O_2) resulting in the formation of hydrogen peroxide (H_2O_2) (in acidic solution) or hydrogen peroxide anions (HO_2^-) (in alkaline solutions).

Refs.: [i] Hoare JP (1974) In: Bard AJ (ed) *The Encyclopedia of the electrochemistry of the elements*, vol. 2. Marcel Dekker, New York; [ii] Berl WG (1943) *Trans Electrochem Soc* 83:253

RH

Berzelius, Jöns Jacob



(Courtesy of History of Technology Division, Technical University of Denmark)

(Aug. 20, 1779, near Linköping, Sweden – Aug. 7, 1848, Stockholm, Sweden). Berzelius was one of the founders of modern chemistry [i, ii]. He studied about 2000 compounds; discovered Ce, Se, Si, and Th; first used the term “organic chemistry”; invented series of *electronegativities*; suggested symbols for elements based on Latin letters (which have been modernized later) and invented modern chemical formulas; proposed the terms: isomerism, allotropy, catalysis, protein, polymer, halogen, and electronegative; proved law of definite proportions; generated first accurate list of atomic weights. Berzelius proposed ionic nature of chemical bonds that are caused, according to his theory, by electrostatic attraction between two atoms if one of the atoms was positively, and the other negatively charged. His particular contributions to electrochemistry include the first electrolysis of salts and the invention of a mercury cathode.

Refs.: [i] Jorpes JE (1970) *Jacob Berzelius, his life and work*. University of California Press, Berkeley; [ii] Ihde AJ (1961) In: Farber E (ed) *Great chemists*. Interscience Publishers, New York, pp 385–402

EK

Besenhard, Jürgen Otto



(May 15, 1944, Regensburg, Germany – Nov. 4, 2006 in Graz, Austria) Besenhard studied chemistry at the University of Munich where he also received his Ph.D. Since that time he has dedicated his research to \rightarrow *lithium batteries*, and he became one of the pioneers in that field. In 1977 he was post-doc with Roger Parsons, and in 1986 he became Full Professor at the University of Münster, where he expanded his research activities to a very large number of research topics from applied electrochemistry, and still maintained his activities in lithium electrochemistry. In 1993 he became head of the Institute of Chemistry and Technology at Graz University of Technology in Austria. Besenhard is the author or co-author of more than 800 publications, 50 patents, and was editor of the ‘Handbook of Battery Materials’ [i].

Refs.: [i] Besenhard JO (ed) (1999) *Handbook of Battery Materials*. Wiley-VCH, Weinheim; [ii] Obituary: Winter M (2007) *J Solid State Electrochem*

Beta cell — (also called beta battery or sodium sulfur battery) is a high temperature secondary Na/ β -Al₂O₃/S battery cell. The anode metal Na is especially attractive on account of its high electrode potential and low atomic mass, which gives a high specific energy. \rightarrow β -alumina (Na₂O–11Al₂O₃) is an ideal solid electrolyte with fast Na⁺ conduction. The cell operates at 300 to 350 °C and exhibits improved performance compared to ambient-temperature batteries, i.e., the ionic resistivity of β -alumina at 300 °C is 2 to 5 Ω cm, comparable to that of an aqueous NaCl solution. The cell must be sealed to prevent reaction with water and air. The preferred phase for battery operation with the highest ionic conductivity is β'' -alumina (typical composition Na_{1.67}Mg_{0.67}Al_{10.33}O₁₇). The beta cell uses a molten Na cathode, the solid β'' -alumina electrolyte, and a molten sulfur–sodium polysulfide mixture as the anode, respectively. Discharge involves $\text{Na} \rightleftharpoons \text{Na}^+ + \text{e}^-$, followed

by diffusion of Na⁺ through β'' -alumina ceramic to the cathode, where reduction of sulfur occurs in two steps, i.e.: $2\text{Na}^+ + 5\text{S} + 2\text{e}^- \rightleftharpoons \text{Na}_2\text{S}_5$, and $\frac{2x}{5}\text{Na}^+ + (1 - \frac{x}{5})\text{Na}_2\text{S}_5 + \frac{2x}{5}\text{e}^- \rightleftharpoons \text{Na}_2\text{S}_{5-x}$, respectively. The first reaction gives an open-circuit voltage of 2.08 V, whereas the second reaction gives 2.08 to 1.76 V. A mixture of Na₂S₅ and unreacted sulfur in the first stage is converted to Na₂S₅, and further reaction proceeds in a single phase from Na₂S₅ to Na₂S_{5-x} by addition of Na⁺. The cell voltage decreases linearly with the Na composition and the discharge is stopped at 1.76 V, corresponding to the composition of Na₂S₃.

Currently, the full size cell (energy density: 200 Wh kg⁻¹, capacity: 15 Ah) is designed for a cycle of 5 h discharge and 7 h charging with a round-tip efficiency of 76%. Individual cells have regularly shown lives of 1000 to 2000 cycles. Better-quality, fine-grained materials are now routinely produced, and it has been found that the addition of ZrO₂ can refine the grain size of the ceramic. Also, special sulfur electrode designs, including the use of graded resistivity shaped graphite felt current collectors (\rightarrow *carbon electrodes*, subentry \rightarrow *carbon felt electrode*), have improved the rechargeability of the sulfur electrode. 10 to 50 Ah batteries are now common. Newer beta cell designs comprise a flat solid electrolyte disc concept instead of a tubular design. This flat separator, typically 0.3 mm thick, offers uniform discharge and excellent thermal conduction and allows high specific power of 600 W kg⁻¹ and 1.65 kW cm⁻³ for a bipolar cell, i.e., a higher performance by a factor 5 to 6 compared to the cylindrical cell design.

FS Refs.: [i] Julien C (1997) *Solid state batteries*. In: Gellings PJ, Bouwmeester HJM (eds) *The CRC handbook of solid state electrochemistry*. CRC Press, Boca Raton, pp 374–410; [ii] Braithwaite JW, Auxer WL (2002) *Sodium-beta batteries*. In: Linden D, Reddy TB (eds) *Handbook of batteries*, 3rd edn. McGraw-Hill, New York, pp 40.00–40.31

MHer

Beutner, Reinhard Heinrich



(Reproduced with permission of: ‘Archiv zur Geschichte der Max-Planck-Gesellschaft, Berlin-Dahlem’)

(April 10, 1885, Berlin, Germany – April 15, 1964, Scranton, PA, USA) Ph.D. 1908 at “Technische Hochschule Karlsruhe” in the group of \rightarrow *Haber* with studies on

→ *solid electrolyte galvanic cells* [i–ii]. Beutner studied the → *electromotive forces* at interfaces of solid metals with solid electrolytes, at that time a newly emerging field of electrochemistry. Later he performed pioneering studies on electromotive forces at the interface of aqueous and non-aqueous solutions [iii]. These studies were performed at the Rockefeller Institute, New York, in the group of → *Loeb*. Beutner reported for the first time series of electromotive forces at these interfaces for different electrolytes and different organic solvents (→ *interface between two immiscible electrolyte solutions*). He published three important books [iii–v] and held leading position in US Medical Research laboratories [vi].

Refs.: [i] Beutner R (1908) *Neue Galvanische Elemente* (PhD thesis). Druck von W Pilz, Berlin; [ii] Haber F (1908) *Ann Phys* 26:927, esp pp 947 (together with R Beutner); [iii] Beutner R (1920) *Die Entstehung elektrischer Ströme in lebenden Geweben und ihre künstliche Nachahmung durch synthetische organische Substanzen* (The origin of electric currents in living tissues and their artificial simulation with the help of synthetic organic compounds). Ferdinand Enke Verlag, Stuttgart; [iv] Beutner R (1933) *Physical chemistry of living tissues and life processes*. The Williams & Wilkins Company, Baltimore; [v] Beutner R (1938) *Life's beginning on earth*. The Williams & Wilkins Company, Baltimore; [vi] Wußing H (ed) (1999) *JC Poggendorff Biographisch-Literarisches Wörterbuch der exakten Naturwissenschaften*, vol. 8, Part 1. Wiley-VCH, Weinheim, p 384

FS

Biamperometry — Whereas in → *amperometry* the → *current* is limited by the electrode process proceeding at one → *indicator electrode* (and the → *counter electrode* has no effect), in biamperometry the current flowing between two indicator electrodes is measured, i.e., both electrodes can limit the overall current. This approach is useful in following some → *titrations*, and it may lead to zero current (dead-stop) at the equivalence point (dead-stop titration). Example: iodine in an iodide solution is titrated with As(III). Two platinum electrodes with a potential difference of around 100 mV prompt iodine to be reduced on one electrode and iodide being oxidized at the other. The two processes maintain an almost constant current until the endpoint when iodine is exhausted.

Refs.: [i] Foulk CW, Bawden AT (1926) *J Am Chem Soc* 48:2045; Bard AJ, Faulkner LR (2000) *Electrochemical methods*. Wiley, New York, p 439

FS

Bias — (*of error*) A measure of the → *systematic error* associated with an analysis. It is the difference between the → *population mean* and the accepted or → *true value* [i].

Ref.: [i] Harris D (2002) *Quantitative chemical analysis*. WH Freeman, New York

FG

Bifunctional mediator — is a → *catalyst* containing two functional groups, both of which are involved in the rate-controlling step. The corresponding catalytic effect is larger than expected for catalysis by species containing only one of these functional groups. See also → *mediator*.

VM

Biilmann, Einar Christian Saxtorp



(May 10, 1873, Frederiksberg, Copenhagen, Denmark – Aug. 10, 1946, Copenhagen, Denmark) Biilmann started to study medicine, but obtained a Master degree in Chemistry in 1897. Later he became assistant of S. M. Jørgensen, a well-known coordination chemist. In 1904 he obtained his doctorate for studies in organic chemistry. Biilmann spent one year in the laboratory of Emil Fischer in Berlin, and in 1907 he was appointed professor of chemistry at the University of Copenhagen. Biilmann is best known for the introduction of the → *quinhydrone electrode* for → *pH* determinations.

Refs.: [i] Biilmann E (1921) *Ann Chim* 15:109; [ii] Stock JT (1989) *J Chem Educ* 66:910

FS

Bimetallic electrodes → *electrode, materials*, subentry → *bimetallic electrodes*

BIMEVOX — (**bismuth metal vanadium oxide**) is a family of → *solid electrolytes* with a high oxygen-ionic conductivity, based on high-temperature polymorph of bismuth vanadate, γ - $\text{Bi}_4\text{V}_2\text{O}_{11}$, stabilized by partial substitution. The crystal structure of the BIMEVOX family belongs to the Aurvillius series and consists of alternating $\text{Bi}_2\text{O}_2^{2+}$ and perovskite-like $\text{VO}_{3,5}^{2-}$ layers, with oxygen vacancies in the perovskite layers providing ion migration. Moderate → *doping* into the vanadium sites is

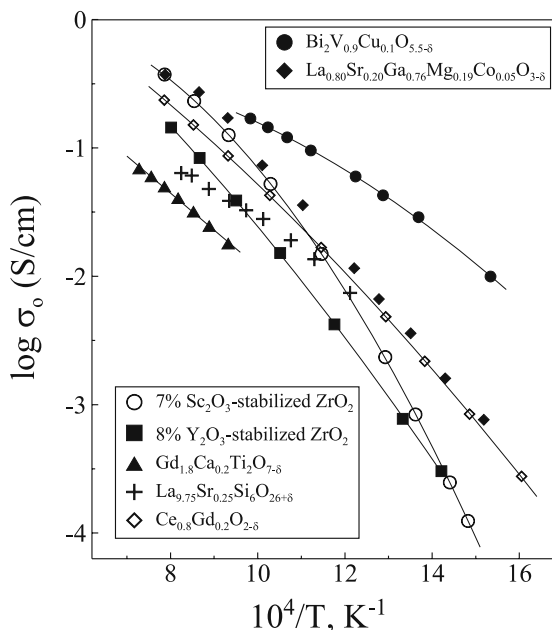

BIMEVOX — Figure. Oxygen ionic conductivity of solid oxide electrolytes at atmospheric oxygen pressure. See Ref. [ii] for details

necessary to stabilize the highly conductive γ - $\text{Bi}_4\text{V}_2\text{O}_{11}$ lattice down to low temperatures [i, ii]. The \rightarrow *solid solutions* stabilized by partial substitution with transition metal cations, such as $\text{Bi}_2\text{V}_{1-x}\text{Me}_x\text{O}_{5.5-\delta}$ ($\text{Me} = \text{Cu}, \text{Ni}$, and $0.07 \leq x \leq 0.12$), exhibit very high ionic conduction and oxygen ion \rightarrow *transport numbers* close to unity at temperatures below 900 K under oxidizing conditions (see Fig. 1). Major disadvantages of bismuth vanadate-based ceramics, limiting their application, include a low mechanical strength, easy reducibility, and extremely high chemical reactivity.

Refs.: [i] Vanier RN, Mairesse G, Abraham F, Nowogrocki G (1994) *Solid State Ionics* 70/71:248; [ii] Kharton VV, Marques FMB, Atkinson A (2004) *Solid State Ionics* 174:135

Binary electrolyte — An electrolyte consisting of anions and cations with equal absolute charge numbers, e.g., KCl (1:1), MgSO_4 (2:2).

Ref.: [i] Newman J, Thomas-Alyea KE (2004) *Electrochemical systems*, 3rd edn. Wiley Interscience, Hoboken, pp 110, 277, 299

Biochemical standard potential \rightarrow *potential*

Biocorrosion — The deterioration of solid materials, organic as well as inorganic by living organisms. These can

be higher organisms, like barnacles and mussels, and also microorganisms [i–iii]. Microbial corrosion, or microbiologically influenced corrosion can be the result of a direct attack of solid phases, e.g., the reduction of iron oxides by *Shewanella* or *Geobacter* [iii] species, or it may be the result of corrosive action of metabolites produced by the microbes. Such metabolites may be inorganic or organic acids (acidification) or also the production of corrosive compounds like H_2S under anaerobic conditions. Biofilms on metals do not produce a new kind of corrosion, but they affect the well-known corrosion mechanisms and may change considerably the rate of corrosion.

Refs.: [i] Heitz E, Flemming HC, Sand W (eds) (1996) *Microbially influenced corrosion of materials*. Springer, Berlin; [ii] Dexter SC (2005) *Microbiological effects*. In: Baboian R (ed) *Corrosion tests and standards*, ASTM manual 20, 2nd edn. American Society for Testing and Materials, Philadelphia, pp 509–522; [iii] Dexter SC (2003) *Microbiologically influenced corrosion*. In: *Corrosion fundamentals and protection*, ASM Handbook, vol. 13A. ASM International, Metals Park, pp 398–416; [iv] Lovley DR, Giovannoni SJ, White DC, Champine JE, Phillips EJP, Gorby YA, Goodwin S (1993) *Arch Microbiol* 159:336

FS

Bioelectrochemistry — is a discipline that includes all aspects of the overlap of biology and \rightarrow *electrochemistry* [i], including all electrochemical phenomena of living cells and organisms, as, for instance, \rightarrow *nerve conduction*, muscle contraction, membrane phenomena and electrical organs. Whereas the modern, interdisciplinary bioelectrochemistry was established by Giulio Milazzo (1912–1993), the origin of bioelectrochemistry goes back to \rightarrow *Galvani* and \rightarrow *Volta*.

In electrochemistry, the term bioelectrochemistry is generally used to indicate electrochemistry *of* or *in* biological systems [ii]. Examples are: \rightarrow *enzyme electrodes*, \rightarrow *biofuel cells*, \rightarrow *biosensors*, \rightarrow *immunoassays*, *electrochemical* \rightarrow *protein electrochemistry*.

Refs.: [i] Caplan SR, Miller IR, Milazzo G (eds) (1995) *Biochemistry: General introduction*. Birkhäuser Verlag, Basel; [ii] Bard AJ, Stratmann M, Wilson GS (eds) (2002) *Bioelectrochemistry*. *Encyclopedia of electrochemistry*, vol. 9. Wiley-VCH, Weinheim

US

Biofuel cells — also referred to as biochemical, or bioelectrochemical \rightarrow *fuel cells*, exploit biocatalysts for the direct conversion of chemical energy to electrical energy. Based on the nature of the biocatalyst, biofuel cells are generally classified as enzymatic fuel cells and microbial fuel cells [i]. Enzymatic fuel cells use purified enzymes to catalyze the oxidation of substrates at the \rightarrow *anode* and

VK

FG

B

the reduction of an oxidant at the \rightarrow *cathode*. Depending on the targeted substrate (fuel) the oxidative reactions are usually catalyzed using dehydrogenases (e.g., lactate dehydrogenase, alcohol dehydrogenase, glucose dehydrogenase) or oxidases (glucose oxidase GOx) [ii]. For the cathodic reaction various oxidases (cytochrome oxidase, bilirubin oxidase), laccases (horseradish peroxidase), or peroxidases have been used to catalyse the reduction of oxygen or hydrogen peroxide. Different strategies have been followed to immobilize the biocatalysts to the fuel cell electrodes, including adsorptive immobilization, cross-linking, and the embedding in \rightarrow *conducting polymer* matrices \rightarrow *polyaniline*, \rightarrow *polypyrrole*. Electron transfer from the enzyme to the electrode is achieved either via direct electron transfer (DET) or mediated electron transfer (MET) [iii].

Based on the high specificity of enzymatic reactions enzymatic fuel cells can be constructed compartmentless, i.e., without a physical separation of the anodic and the cathodic compartments. This allows miniaturization of the devices, e.g., for biomedical (implantable) devices and \rightarrow *biosensors* [iii].

In microbial fuel cells living microorganisms serve as biocatalysts for the conversion of chemical energy to electricity. Since the majority of microorganisms are electrochemically inactive some early microbial fuel cells required the use of artificial electron-shuttling com-

pounds (mediators) such as thionine or neutral red to be added to the bacterial solution in order to establish an \rightarrow *electron transfer* to the fuel cell anode. As the use of such redox mediators is technologically impractical and environmentally questionable, the development of mediator-based microbial fuel cell concepts appears abandoned. Recent MFC types are typically “mediator-less”, i.e., they do not require artificial redox mediators for their operation. The classification as mediator-less, however, not exclude electron mediation via microbial electron shuttling compounds [iv]. Different electron transfer mechanisms have been identified and used (Fig.), however, many mechanisms are still under investigation.

Thus, electrons can be directly transferred (DET) to the anode via the cell membrane (a) or via so-called nanowires (b) [vi,vii]. Alternatively, mediated electron transfer (MET) can take place via bacterial electron-shuttling compounds [viii] or reduced secondary metabolites like, e.g., hydrogen, formate, or ethanol [v, ix].

Refs.: [i] Bullen RA, Arnot TC, Lakeman JB, Walsh FC (2006) *Biosens Bioelectron* 21:2015; [ii] Katz E, Shipway AN, Willner I (2003) *Biochemical fuel cells*. In: Vielstich W, Gasteiger HA, Lamm A (eds) *Handbook of fuel cells – Fundamentals, technology and applications. Fundamentals and survey of systems*, vol. 1. Wiley, New York; [iii] Barton SC, Gallaway J, Atanassov P (2004) *Chem Rev* 104:4867; [iv] Lo-

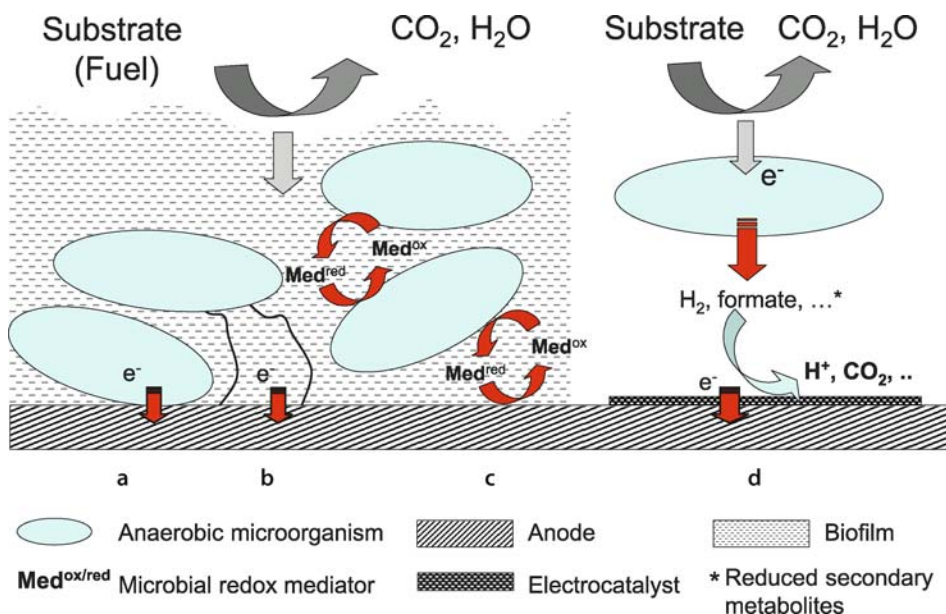

Biofuel cells — Figure. Schematic illustration of identified electron transfer mechanisms in microbial fuel cells. Electron transfer via (a) cell membrane-bound cytochromes, (b) electrically conductive pili (nanowires), (c) microbial redox mediators, and (d) via oxidation of reduced secondary metabolites [v]

gan BE, Hamelers B, Rozendal R, Schröder U, Keller J, Freguia S, Aelterman P, Verstraete W, Rabaey K (2006) *Environ Sci Technol* 40:5193; [v] Rosenbaum M, Zhao F, Schröder U, Scholz F (2006) *Angewandte Chemie int Ed* 45:6658; [vi] Bond DR, Lovley DR (2003) *Appl Microbiol Biotechnol* 69:1548; [vii] Gorby YA, Yanina S, McLean JS, Rosso KM, Moyles D, Dohnalkova A, Beveridge TJ, Chang IS, Kim BH, Kim KS, Culley DE, Reed SB, Romine MF, Saffarini DA, Hill EA, Shi L, Elias DA, Kennedy DW, Pinchuk G, Watanabe K, Ishii SI, Logan B, Neelson KH, Fredrickson JK (2006) *PNAS* 103:11358; [viii] Rabaey K, Boon N, Verstraete W, Höfte M (2005) *Environ Sci Technol* 39:3401; [ix] Niessen J, Schröder U, Rosenbaum M, Scholz F (2004) *Electrochem Commun* 6:571

US

Biosensors — Sense organs have developed during evolution by adapting the organism towards the properties of their environment. They recognize chemical signals by the binding to structurally complementary receptor areas followed by the transduction of this event into electrical nerve impulses. The biosensors represent the technical counter part [i] by coupling the recognition by a biological recognition element, e.g., enzymes, antibodies, nucleic acids, receptors, and recognition systems, e.g., organelles, cells, tissues, with a chemical or physical sensor [ii] (Table). Different transducer types, e.g., electrochemical, optical, piezoelectric, thermal, or magnetic, transfer the signal from the recognition part to the electrical domain. Biosensors have been classified according to the biological recognition mechanism or the mode of signal transduction or, alternatively, a combination of the two. The characteristic feature of the biosensor is (according to the definition of IUPAC) the **direct** (spatial) contact of the recognition element and the **transducer** [ii]. This integration leads to a compact functional

unit which allows re-usage of the biological component and **miniaturization** of the sensor body. These properties allow for online measurement and are the basis of the combination of different recognition elements on one transducer array resulting in the biochip (Figure). Integration of the biochemical and electronic signal processing have been realized in “intelligent biosensors” and BioFETs, resp. The combination of the biosensor with microfluidics and actuators on a chip has led to total microanalysis systems (μ TAS).

The IUPAC definition may also be extended in respect to biomimetic recognition elements, e.g., aptamers and molecularly imprinted polymers, which are derived from biology (Table).

On the other hand, biochemical tools used for analytical purposes which do not include sensor components should not be assigned as a biosensor. This holds for molecular or cellular recognition systems with biochemical signal generation, e.g., allosteric enzymes, cells carrying a reporter gene and for bioassays or bio tests which do not include a chemical or physical transducer [iii]. Furthermore, plain chemical sensors which do not contain a biological recognition element, e.g., pH or oxygen electrodes, do not fulfill the criteria of the IUPAC definition in spite of the frequently used term “biological sensor”. See also \rightarrow *enzyme electrode*, \rightarrow *glucose sensor*.

Refs.: [i] Thevenot DR, Toth K, Durst RA, Wilson GS (2001) *Biosens Bioelectron* 16:121; [ii] Cammann K (1977) *Fresenius Z Anal Chem* 287:1; [iii] Scheller F, Schubert F (1992) *Biosensors*. Elsevier, Amsterdam

FSche

Biosensors, conducting polymer based \rightarrow *Conducting polymer based biosensors* [i–xii] make use of the

Biosensors — Table. Types of biosensors

Biochemical receptors	Transducers	Configuration
<i>Biological:</i> Enzymes Antibodies Receptors Nucleic acids Cells	<i>Electrochemical:</i> Amperometric, potentiometric, Conductometric, capacitive ISFET	Biosensor
<i>Biomimetic:</i> Aptamers Ribozymes	<i>Optical:</i> Photometers, interferometers, refractometers, fluorimeters, luminometers	Microanalysis System (μ TAS) Biochip
Molecularly imprinted polymers (MIPs)	<i>Mechanical & Thermodynamic:</i> Thermistors, viscosimeters oscillating quartz crystals <i>Magnetic:</i> Toroids	

electrochemically induced polymerization of suitable monomers such as pyrrole, *N*- and 3-substituted pyrrole derivatives, thiophene, thiophene derivatives, aniline, phenol and phenol derivatives, and azulene for the formation of polymer films at electrode surfaces under simultaneous immobilization of suitable biological recognition elements such as enzymes, antibodies, whole cells, etc. Initially, main focus was directed on using the formed conducting polymer films not only as immobilization matrix but additionally as molecular cable for fast electron transfer between redox sites within the biological recognition compound and the electrode. However, electron transfer between, e.g., polymer-entrapped enzymes and the electrode via the ramified conducting polymer network was prevented due to the far distance between the prosthetic group isolated by the protein shell and the polymer network. In the case of multifactor enzymes exhibiting an internal fast electron transfer pathway (e.g., quinohemoprotein alcohol dehydrogenase) a direct electron transfer via polypyrrole chains was observed [xiii].

Refs.: [i] Zotti G (1992) *Synthetic Metals* 51:373; [ii] Bartlett PN, Cooper JM (1993) *J Electroanal Chem* 362:1; [iii] Trojanowicz M, Krawczynski T, Krawczynski vel T, Krawczyk (1995) *Mikrochim Acta* 121:167; [iv] Schuhmann W (1995) *Mikrochim Acta* 121:1; [v] Adeloju SB, Wallace GG (1996) *Analyst* 121:699; [vi] Wallace GG, Smyth M, Zhao H (1999) *Trends Anal Chem* 18:245; [vii] Cosnier S (1999) *Biosensors & Bioelectronics* 14:443; [viii] Cosnier S (2000) *Appl Biochem Biotechnol* 89:127; [ix] Palmisano F, Zamboni PG, Centonze D (2000) *Fresenius' J Anal Chem* 366:586; [x] Gerard M, Chaubey A, Malhotra BD (2002) *Biosensors & Bioelectronics* 17:345; [xi] Vidal JC, Garcia-Ruiz E, Castillo JR (2003) *Microchim Acta* 143:93; [xii] Trojanowicz M (2003) *Microchim Acta* 143:75; [xiii] Ramanavicius A, Habermüller K, Csöregi E, Laurinavicius V, Schuhmann W (1999) *Anal Chem* 71:3581

WSchu

Biosensors, reagentless — Reagentless biosensors are biosensors in which all components necessary for the overall sensing process are securely immobilized on the transducer surface. Thus, reagentless biosensors do not use any free-diffusing compound with exception of the analyte to be detected. Reagentless biosensors are mainly addressed in amperometric enzyme electrodes and imply an electrode architecture in which a suitable electron-transfer pathway between an immobilized redox enzyme and the electrode surface is tailored using either direct \rightarrow *electron transfer* in monolayer arrangements based on self-assembled monolayers or in redox-polymer based biosensors in which charge transport is achieved by means of electron hopping between polymer bound redox relays.

Refs.: [i] Heller A (1990) *Acc Chem Res* 23:128; [ii] Kulys J, Bilitewski U, Schmid RD (1991) *Anal Lett* 24:181; [iii] Heller A (1992) *J Phys Chem* 96:3579; [iv] Schuhmann W, Kranz C, Huber J, Wohlschlager H (1993) *Synth Met* 61:31; [v] Schmidt HL, Schuhmann W (1996) *Biosens Bioelectron* 11:127; [vi] Schuhmann W (2002) *Rev Mol Biotechnol* 82:425

WSchu

Bipolaron — Bipolarons are double-charged, spinless quasiparticles introduced in solid state physics [i]. A bipolaron is formed from two \rightarrow *polarons* (charged defects in the solid). For chemists the double-charged states mean dications or dianions, however, bipolarons are not localized sites, they alter and move together with their environment. By the help of the polaron–bipolaron model the high conductivity of \rightarrow *conducting polymers* can be explained.

The interaction of polarons produce bipolarons which are uncorrelated charged \rightarrow *solitons*, e.g., in \rightarrow *polyacetylene*, and correlated dications, e.g., in \rightarrow *poly(p-phenylene)* [i]. The bipolarons can take part in both the intrachain and interchain \rightarrow *charge transport* in conducting polymers, which is called spinless conductivity [ii, iii]. Bipolarons are formed at higher charging (doping) levels creating bipolaron bands within the gap of the valence and conducting bands. At high doping levels the electronic structure of the polymer entirely differs from that of the original polymer, and the charged defects overlap spatially along the polymer chain. It causes an elimination of the energy gap between occupied and unoccupied states.

Refs.: [i] Chance RR, Boudreaux DS, Brédas J-L, Silbey R (1986) *Solitons, polarons and bipolarons in conjugated polymers*. In: Skotheim TA (Ed) *Handbook of conducting polymers*, vol. 2, Marcel Dekker, p 825; [ii] Inzelt G (1994) *Mechanism of charge transport in polymer-modified electrodes*. In: Bard AJ (Ed) *Electroanalytical chemistry*, vol. 18, Marcel Dekker; [iii] Lyons MEG (1994) *Charge percolation in electroactive polymers*. In: Lyons MEG (ed) *Electroactive polymer electrochemistry, Part I*, Plenum, New York, p 1

GI

Bipolar electrode — An electrode shared between two neighboring electrolysis cells, this way acting as anode in one and as cathode in the second cell. Useful if cells are series-coupled, since the electrode material itself forms the interconnection between cells. Applied preferably in \rightarrow *secondary batteries*, in \rightarrow *fuel cells*, and in \rightarrow *alkali chloride electrolysis*.

PG

Bipotentiometry — Whereas in \rightarrow *potentiometry* the \rightarrow *potential* of one \rightarrow *indicator electrode* is measured versus the constant potential of a \rightarrow *reference electrode*, in

bipotentiometry the potential difference between two indicator electrodes is measured. This approach is especially useful in following \rightarrow *titrations* provided that the response of the two indicator electrodes differs and that difference should be largest at the equivalence point. The two indicator electrodes may be made from different materials (metals), or in some cases it is sufficient to have two electrodes of the same metal; however, with different surface layers.

Refs.: [i] Kékedy L (1975) *Rev Anal Chem (Tel Aviv)* 3:27; [ii] Schumacher E, Umland F (1977) *Mikrochim Acta* 449:60; [iii] Schumacher E, Umland F (1981) *Neue Titrationsen mit elektrochemischer Endpunktanzeige*. In: Bock R, Fresenius W, Günzler H, Huber W, Tölg G (eds) *Analytiker Taschenbuch, vol. 2*. Springer Verlag, Berlin, pp 197

FS Ref.: [i] Muller P (1994) *Pure Appl Chem* 66:1077

WK

Bipotentiostat — An instrument that can control the potential of two independent \rightarrow *working electrodes*. A \rightarrow *reference electrode* and an \rightarrow *auxiliary electrode* are also needed; therefore the cell is of the four-electrode type. Bipotentiostats are most often employed in electrochemical work with \rightarrow *rotating ring-disk electrodes* and \rightarrow *scanning electrochemical microscopes*. They are also needed for monitoring the electrode-reaction products with probe electrodes that are independently polarized. All major producers of electrochemical equipment offer this type of \rightarrow *potentiostat*. The instruments that can control the potential of more than two working electrodes are called multipotentiostats.

Refs.: [i] Bard AJ, Faulkner LR (2000) *Electrochemical methods*. Wiley, New York; [ii] http://www.ijcambria.com/CHI700C_series_%20bipotentiostats.htm

ZS

Biradical (or diradical) — An even-electron \rightarrow *molecular entity* with two (possibly delocalized) \rightarrow *radical centers* which act nearly independently of each other, e.g.,

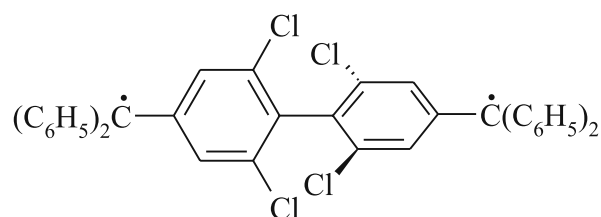

Species in which the two radical centers interact significantly are often referred to as “biradicaloids”. If the two radical centers are located on the same atom, the species are more properly referred to by their generic names: carbenes, nitrenes, etc. The lowest-energy triplet

state of a biradical lies below or at most only a little above its lowest singlet state (usually judged relative to $k_B T$, the product of the \rightarrow *Boltzmann constant*, k_B , and the absolute temperature, T). The states of those biradicals whose \rightarrow *radical centers* interact particularly weakly are most easily understood in terms of a pair of local doublets. Theoretical descriptions of low-energy states of biradicals display the presence of two unsaturated valences (biradicals contain one fewer bond than permitted by the rules of valence): the dominant valence bond structures have two dots, the low-energy molecular orbital configurations have only two electrons in two approximately nonbonding molecular orbitals, two of the natural orbitals have occupancies close to one, etc.

Bismuth electrode (or bismuth–bismuth oxide electrode) \rightarrow *pH-sensitive electrodes*

Bismuth film electrodes — The development of reliable non-mercury electrodes is considered a major challenge for electroanalysis. Bismuth-film electrodes offer an attractive alternative to the use of mercury-coated electrodes in \rightarrow *stripping voltammetry* of trace metals, with an attractive analytical performance. Bismuth-film electrodes offer a well-defined, undistorted and highly reproducible response, excellent resolution of neighboring peaks, high hydrogen evolution, with signal-to-background characteristics comparable to those of common mercury electrodes. Among the alternative (‘non-mercury’) electrodes, the bismuth one thus offers the closest stripping-voltammetric performance to mercury. Such favorable stripping behavior of bismuth electrodes reflects the ability of bismuth to form ‘fused’ alloys with heavy metals.

The design of the bismuth electrode plays a major role in the resulting stripping performance. In most cases, a carbon substrate is used to support the bismuth film. A variety of \rightarrow *carbon electrodes*, of different sizes and geometries, can be used (with the majority of studies employing a glassy carbon disk). Such films can be prepared ex-situ (preplated) or in-situ (by adding 0.25–1.0 ppm bismuth(III) directly to the sample solution, and simultaneously depositing the target heavy metals and bismuth).

Different versions of stripping analysis have been successfully employed in connection to bismuth-film electrodes. While most early studies have been devoted to conventional stripping-voltammetric measurements, recent activity expanded the scope of bismuth elec-

trodes to adsorptive- and potentiometric stripping experiments.

Refs.: [i] Wang J, Lu J, Hocevar S, Farias P, Ogorevc B (2000) *Anal Chem* 72:3218; [ii] Economou A (2005) *Trends Anal Chem* 24:334; [iii] Wang J (2005) *Electroanalysis* 17:1341

JW

Bismuth oxide — Bismuth (Bi) forms a variety of oxide compounds with the Bi cations oxidation state from +2 to +5 [i, ii]. Bismuth oxides, particularly Bi_2O_3 , have numerous applications as components of ceramic materials, glasses, and films having specific electrical and electrochemical properties (\rightarrow *solid electrolytes*, \rightarrow *mixed ionic–electronic conductors*, \rightarrow *electrochromic devices*, high-temperature superconductors, various coatings, glass-ceramic sealants etc.). One attractive phenomenon relates to the very high oxygen-ionic conductivity of the high-temperature polymorph of bismuth (III) oxide, δ - Bi_2O_3 , which has a disordered cubic fluorite-like lattice and forms at temperatures above 978–1013 K [i, iii]. The level of oxygen-ionic transport in undoped δ - Bi_2O_3 is highest among known oxygen \rightarrow *ion conductors*. The stabilization of the δ - Bi_2O_3 phase down to moderate temperatures can be achieved by substitution of bismuth with rare-earth dopants, such as Y, Dy, or Er, and their combinations with higher-valence cations, such as W or Nb. The maximum conductivity in the binary systems is observed for Er- and Y-containing phases, namely $\text{Bi}_{1-x}\text{Er}_x\text{O}_{1.5}$ ($x \approx 0.20$) and $\text{Bi}_{1-x}\text{Y}_x\text{O}_{1.5}$ ($x = 0.23$ –

0.25). However, either binary or ternary \rightarrow *solid solutions* with disordered fluorite structure are metastable at temperatures below 770–870 K, exhibiting a slow phase decomposition and a decrease in the conductivity with time. Other disadvantages of Bi_2O_3 -based solid electrolytes include a low stability towards reduction (see Figure), high thermal expansion and chemical reactivity, and a significant electronic transport. Bismuth oxide is also a component of other ion-conducting phases, such as \rightarrow *BIMEVOX*.

Refs.: [i] Kharton VV, Naumovich EN, Yaremchenko AA, Marques FMB (2001) *J Solid State Electrochem* 5:160; [ii] <http://www.marketresearch.com/map/prod/1190139.html>; [iii] Sammes NM, Tompsett GA, Nafe H, Aldinger F (1999) *J Europ Ceram Soc* 19:1801; [iv] Kharton VV, Marques FMB, Atkinson A (2004) *Solid State Ionics* 174:135

VK

Bjerrum, Niels Janniksen



(© Morten J. Bjerrum)

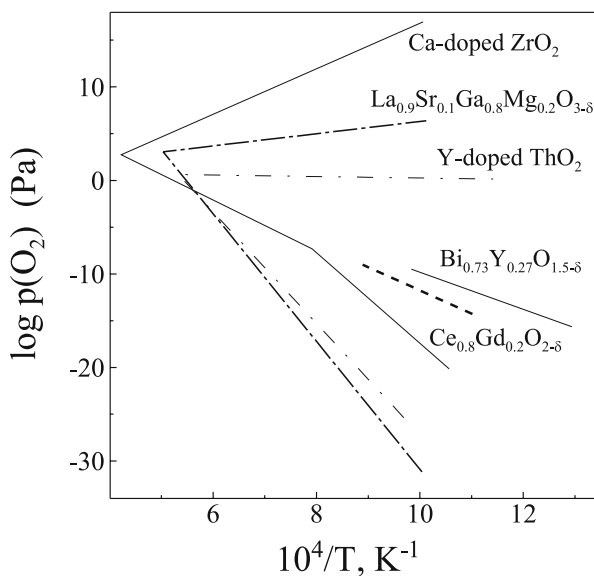

Bismuth oxide — Figure. Comparison of the \rightarrow *electrolytic domain* boundaries for solid oxide electrolyte materials. See ref. [iv] for details

(Mar. 11, 1879, Copenhagen, Denmark – Sep. 30, 1958, Copenhagen, Denmark) Bjerrum studied chemistry in 1905 in Leipzig (Germany), 1907 in Zurich (Switzerland), 1910 in Paris (France), and 1911 in Berlin (Germany). Full doctorate in 1908, University of Copenhagen (Denmark). 1914–1949 Professor at the Royal Veterinary and Agricultural College in Copenhagen. Bjerrum worked on protolysis equilibria [i], amphoteric electrolytes, indicators, activity coefficients of concentrated electrolytes [ii], heat capacity of gases, infrared spectroscopy, colloid chemistry, kinetic theory, salt effects in kinetics, and complex formation equilibria. Bjerrum introduced the \rightarrow *log c-pH diagrams* [iii]. In 1909 he was the first to suggest that strong electrolytes are completely dissociated, which was strongly debated by \rightarrow *Arrhenius*. On the basis of spectroscopic evidence he attributed the conductivity changes to interionic forces. He also corroborated the theory of ion-pair formation (association of ions) [iii]. For more biographical details see [iv, v].

Refs.: [i] Bjerrum N (1914) *Die Theorie der alkalimetrischen und azidimetrischen Titrierungen*. Verlag von Ferdinand Enke, Stuttgart; [ii] Bjerrum N (1918) *Z Elektrochem* 24:321; [iii] Bjerrum N (1915) *Sammlung chemisch und chemisch-technischer Vorträge* 21:1; [iv] Bjerrum N (1926) *K dansk vidensk Selsk* 7 No 9; [v] Nielsen AK (2001) *Dansk Kemi* 82:38; [v] Brosset C, Sillén LG (1958) *Svensk Kem Tidskr* 70:432; [vi] Nielsen AK (ed) (2004) *Niels Bjerrum (1879–1958). Liv og værk*. The Danish Society for History of Chemistry, Copenhagen

FS

Blank determination — A process in which all steps of an analysis are performed in the absence of the → *analyte* [i].

Ref.: [i] Skoog D, West D, Holler F, Crouch SR (2003) *Fundamentals of analytical chemistry*, 8th edn. Brooks/Cole, Belmont

FG

Blocking boundary/interface (also called “reflective boundary”) — A conducting media contains mobile charge carriers which are not bound to a certain spatial region and may be transported to distances well beyond the molecular scale, contrary to bound charges (induced or permanently existing) which can only be displaced at the molecular scale under the influence of an external electric field. The mobile charges can be of ionic or electronic type (the latter includes “free” electrons in metals, hopping electrons, or → *holes* in semiconductors, delocalized charged segments of a conducting polymer matrix called → *polarons* and → *bipolarons*, or cation-radicals and dications, etc.). This conducting phase forms boundaries with other media (which may also be conducting or insulating). Frequently, such a boundary is “blocking”, i.e., it does not allow an exchange by charged species across the → *interface* and consequently the passage of a → *faradaic current*. It is usually the case of an interface between a conducting and an insulating phase (or two insulating ones). This situation may also occur at the contact of two conducting media which possess mobile charge carriers of different types. Important examples are: electronic conductor (metal, semiconductor...)|electrolyte solution (without solute electroactive species), two ionic conductors with different types of mobile ions in these phases, interface of two immiscible liquids (each liquid must contain “specific” ions which cannot penetrate in significant amounts into another phase). The concept of a blocking interface may also be applicable for a contact of two media having one or several corresponding mobile charge carriers so that one could theoretically expect an → *electron* or/and → *ion transfer* across the boundary but in practice this exchange is so slow due to an interfacial

barrier that it can be disregarded (a thin insulating layer between two electronic conductors, an adsorbed layer of nonpolar molecules for the ion exchange...).

An important example of a system with a blocking boundary is an electrode coated with a conducting layer (whose thickness is sufficiently great compared to the internal Debye screening length) in contact with a solution if the film|solution boundary does not allow the interfacial exchange of the electroactive species diffusing inside the layer. The nonstationary distribution of this species inside the layer corresponds to → *finite diffusion* problem. Its solution for the film with a blocking external boundary and with the concentration modulation at the electrode|film contact in the course of the passage of an alternating current results in one of two expressions for “finite-Warburg impedance” for the contribution of the layer: $Z_{\text{layer}} = \tau_d (C(0))^{-1} \coth(i\omega\tau_d)^{1/2} / (i\omega\tau_d)^{1/2}$ containing the characteristic → *diffusion time*, $\tau_d = L^2/D$ (L , layer thickness, D , → *diffusion coefficient*), and the low-frequency capacitance, $C(0) = dQ/dE$, this derivative being equal to the ratio of the charge, dQ , to pass through the circuit to change the equilibrium concentration of electroactive species inside the film, to the small-amplitude change of the external potential, dE .

Ref.: [i] Retter U, Lohse H (2005) *Electrochemical impedance spectroscopy*. In: Scholz F (ed) *Electroanalytical methods*. Springer, Berlin

MAV

Blodgett, Katharine Burr — (Jan. 10, 1898 Schenectady, N.Y., USA – Oct. 12, 1979, Schenectady, N.Y., USA) Katharine Blodgett attended the Bryn Mawr College, a women’s college in Pennsylvania, where she received a degree in physics. → *Langmuir*, whom she met at a visit of the General Electric Company, encouraged her to continue her education and aim at a position at GE. In 1917 she entered the University of Chicago and in 1918 she received a MS. Langmuir hired her as his assistant at GE, and in 1924 she was accepted at Sir Ernest Rutherford’s Cavendish Laboratory. In 1926 she was the first woman to receive a Ph.D. in physics from the University of Cambridge. In 1926 she returned to GE to continue her work with Langmuir. Langmuir had previously developed a technique to transfer monolayers from a water surface to a metal plate. Blodgett developed the technique for multilayer films which are now known as → *Langmuir–Blodgett films* [i, ii].

Refs.: [i] Blodgett KB (1932) *J Am Chem Soc* 57:1007; [ii] Blodgett KB, Langmuir I (1937) *Phys Rev* 51:964

FS

Bockris–Devanathan–Müller model → *double-layer models*

B

Bode plot — Experimental data for complex \rightarrow impedance, Z , measured for a set of \rightarrow frequency values, $\omega = 2\pi f$ (f , in hertz), may be analyzed with the use of various coordinates. One of the most popular treatments is based on Bode plots: the absolute value of Z (“magnitude of impedance”) and its argument (“phase angle”), $|Z|$ and $\arg Z$ (or their logarithms), respectively, are presented as a function of the decimal logarithm of frequency, $\log f$ (called “Bode magnitude and Bode phase plots”). Sometimes, the same terminology is used for similar graphs for other complex characteristics, \rightarrow admittance: $Y = Z^{-1}$, complex capacitance: $C(\omega) = Y(\omega)/i\omega$ or $C(\omega) = (i\omega(Z(\omega) - R(\infty)))^{-1}$, $R(\infty)$ being the high-frequency limit of impedance, e.g., $|C|$ and $\arg C$ as functions of $\log f$.

Refs.: [i] Bard AJ, Faulkner LR (2001) *Electrochemical methods*. Wiley, New York; [ii] Retter U, Lohse H (2005) *Electrochemical impedance spectroscopy*. In: Scholz F (ed) *Electroanalytical methods*. Springer, Berlin; [iii] Barsoukov E, Macdonald JR (ed) (2005) *Impedance spectroscopy. Theory, experiment, and applications*. Wiley, Hoboken

MAV

Bois-Reymond, Emil Heinrich du

(Nov. 7, 1818, Berlin, Germany – Dec. 26, 1896, Berlin, Germany) The son of a family of French refugees in Germany; studied theology, philosophy, mathematics, geology, and finally medicine in Berlin and Bonn. In 1843 he wrote his doctoral thesis about the understanding the old Greeks and Romans had of electric fishes. In 1845 founded together with E.W. von Brücke and H. Dove the Physical Society in Berlin. In 1846 he finished his habilitation as physiologist, became in 1855 extraordinary Professor, and in 1858 full Professor of Physiology at the University of Berlin. Throughout his life du Bois-Reymond studied electric phenomena in the living world and he is regarded as one of the founders of \rightarrow electrophysiology.

Ref.: Beneke K (1999) *Mitteilungen der Kolloid-Gesellschaft* 8:92

Boltzmann, Ludwig Eduard

(Feb. 20, 1844, Vienna, Austria – Sep. 5, 1906 in Duino, Austro-Hungarian Empire, now Italy) is justly famous for his invention of statistical mechanics. At different times in his life he held chairs in theoretical physics at Graz, and in mathematics at Vienna. He also lectured in philosophy. His principal achievement, and the trigger for innumerable vitriolic attacks from the scientific establishment, was his introduction of probability theory into the fundamental laws of physics. This radical program demolished two centuries of confidence that the fundamental laws of Nature were deterministic. Astonishingly, he also introduced the concept of discrete energy levels more than thirty years before the development of quantum mechanics.

Among Boltzmann’s discoveries were the logarithmic law connecting entropy and probability, the Stefan–Boltzmann law giving the energy flux emitted by a black body at temperature T , the Maxwell–Boltzmann formula for the distribution of molecular speeds in a gas, and the Boltzmann distribution formula for the fractional number of particles occupying discrete energy levels in a closed system at equilibrium. In 1906, while on holiday with his wife and daughter at the Bay of Duino, near Trieste, he hanged himself. A version of the entropy formula that he inspired, *viz.*

$$S = k_B \ln W$$

is engraved on his tombstone. Here, S is the \rightarrow entropy, k_B is the \rightarrow Boltzmann constant, and W is the number of possible microstates corresponding to the macrostate of the system.

“When a true genius appears in the world, you may know him by this sign, that the dunces are all in confederacy against him.” Jonathan Swift, *Thoughts on Various Subjects* (1706).

SF

Boltzmann constant — (k or k_B) is the physical constant relating the thermal energy of an equilibrium system

FS

(per accessible degree of freedom) to the practical thermometric temperature scale (based on absolute zero and the triple point of water). Its units are joules per kelvin. Although widely attributed to Boltzmann, it was actually Max → Planck who first introduced the symbol k , and gave an accurate value for it, in his famous derivation of the law of black body radiation [i]. The 2006 CODATA recommended value [ii] of k is $1.3806504(24) \times 10^{-23} \text{ J K}^{-1}$.

Refs.: [i] Planck M (1901) *Annalen der Physik*, 4:553; [ii] Mohr PJ, Taylor BN, Newell DB (2007) *The 2006 CODATA Recommended Values of the Fundamental Physical Constants (Web Version 5.0)*

Boltzmann distribution — The Boltzmann distribution describes the number N_i of indistinguishable particles that have energy E_i , after N of them have been independently and identically distributed among a set of states i . The probability density function is

$$\frac{N_i}{N} = \frac{g_i \exp(-E_i/k_B T)}{Z(T)}, \quad (1)$$

where k_B is the Boltzmann constant, T is the thermometric temperature (assumed uniform), g_i is the number of states having energy E_i (i.e., the degeneracy of the states), and $Z(T)$ is the partition function (*Zustandsumme*). An important insight from the Boltzmann distribution is that the energy in a collection of molecules at equilibrium is not distributed uniformly, it is distributed exponentially. This means that a small fraction of the molecules have energies that are very much higher than the average.

Born, Max



(© The Nobel Foundation)

(Dec. 11, 1882, Breslau, Germany, now Wrocław, Poland, – Jan. 5, 1970, Göttingen, Germany) He studied in Breslau, Heidelberg, Zurich, Cambridge, and Göttingen, first law and philosophy, later mathematics (among

his teachers were Felix Klein, David Hilbert and Hermann Minkowski), and finally physics and astronomy (under Karl Schwarzschild). He received his Ph.D. in 1907 and habilitation in 1909 at the University of Göttingen. In 1919, after a period in the German army, he became a professor at the University of Frankfurt am Main, and then professor at Göttingen in 1921. In 1920 he showed that the free energy of solvation of an ion had a very simple dependence on the ionic charge, the ionic radius, and the dielectric constant of the solvent [i]. In 1926, in collaboration with Robert Oppenheimer, he propounded the now-famous “Born–Oppenheimer approximation” which provides the foundation for nearly all modern computational studies of chemical binding and reactivity [ii]. Finally, throughout the same period, he maintained a famous correspondence with → Einstein, in which he argued in favor of his (Born’s) statistical interpretation of the wavefunction in quantum mechanics. Born belatedly received the Nobel Prize for this work in 1954 [iv]. Tragically, Born was forced to leave Göttingen in 1933 because of his Jewish descent. In 1935–1936 he worked for six months in Bangalore at the Indian Institute of Science with C. V. Raman. From 1936 to 1953 he stayed in Edinburgh, Scotland, as Tait Professor of Natural Philosophy. Following his retirement he returned to Germany, where he died in 1970 [vi]. See also → Born equation, → Born–Haber cycle, → Born–Mayer equation, and → Born solvation energy.

Refs.: [i] Born M (1920) *Z Phys* 1:45; [ii] Born M, Oppenheimer JR (1927) *Ann Phys* 84:457; [iii] Born M (1954) *The statistical interpretation of quantum mechanics. Nobel Lecture*; [iv] <http://nobelprize.org/index.html>; [vi] Thorndike Greenspan N (2005) *The end of the certain world. The life and science of Max Born. The Nobel physicist who ignited the quantum revolution. Basic Books (German translation: Thorndike Greenspan N (2006) Max Born – Baumeister der Quantenwelt. Elsevier, München)*

FS, SF

Born equation — This equation gives the free energy of a sphere of charge ze and radius r , immersed in a medium of permittivity, ϵ , relative to the gaseous ion as the reference state. The solvent is assumed to be a continuum, and no specific solvent–solvent or solvent–ion interactions are considered. This assumption is inadequate in aqueous solution, however, on the basis of the → Gibbs energy that can be calculated by the Born equation [i], a useful approximation of the relative hydration of ions can be made:

$$\Delta G_S = -\frac{N_A z^2 e^2}{8\pi\epsilon_0 r} \left(1 - \frac{1}{\epsilon_r}\right).$$

ϵ_0 is the \rightarrow permittivity of the vacuum; ϵ_r is the \rightarrow dielectric constant of the medium; z is the charge of the ions; e is the \rightarrow elementary electric charge; N_A is the Avogadro constant.

ΔG_s is also referred to as the free energy of \rightarrow solvation of the ions in the respective medium. The Born energy (ΔG_s) required to transfer one mole of ions from one phase with dielectric constant ϵ_1 into another phase of dielectric constant ϵ_2 , is given by [iii]:

$$\Delta G_s = -\frac{N_A z^2 e^2}{8\pi\epsilon_0 r} \left(\frac{1}{\epsilon_1} - \frac{1}{\epsilon_2} \right).$$

The last equation, with several correction factors, has been used to accurately calculate the solvation energies of spherically distributed charges [iii], and to nonspherical charged and polar groups [iv, v]. Those equations are known as Modified Born Equations [iv–vi]. It is worth noting that the Born equation has been also used by Marcus for the description of the kinetics of the outer-shell electron transfer [vii, viii].

Refs.: [i] Born M (1920) *Z Phys* 1:45; [ii] Marcus Y (1997) *Ion properties*. Marcel Dekker, New York; [iii] Rashin AA, Honig B (1985) *J Phys Chem* 89:5588; [iv] Stilly WC, Tempczyk A, Hawley RC, Hendrickson TA (1990) *J Am Chem Soc* 112:6127; [v] Rashin AA (1990) *J Phys Chem* 94:1725; [vi] Shoichet BK, Leach AR, Kuntz ID (1999) *Proteins* 34:4; [vii] Marcus RA (1977) *Theory and application of electron transfer at electrodes and in solutions*. In: Rock PA (ed) *Special topics in electrochemistry*. Elsevier, Amsterdam, pp 61; [viii] Millery CJ (1995) *Heterogeneous electron transfer kinetics at metallic electrodes*. In: Rubinstein I (ed) *Physical electrochemistry*. Marcel Dekker, New York, pp 46–47

RG

Born–Haber’s cycle — Hess’s law establishes that the enthalpy of a reaction is the same independently whether the reaction proceeds in one or several steps. It is a consequence of the first law of thermodynamics, which states the conservation of energy. \rightarrow Born and \rightarrow Haber applied Hess’s law to determine the \rightarrow enthalpy of formation of an ionic solid. The formation of an ionic crystal from its elements according to Born–Haber’s cycle can be represented by the following diagram.

It is necessary that

$$\Delta H_f = \Delta H_{AM} + \Delta H_{AX} + \Delta H_{EI} + \Delta H_{AE} + U_0.$$

The terms ΔH_{AM} and ΔH_{AX} constitute the enthalpies of atomization of the element and the nonmetal respectively, ΔH_{EI} is the ionization enthalpy of the metal, ΔH_{AE} is the ionization enthalpy of the nonmetal, and U_0 is the lattice energy. For gaseous diatomic nonmetals, ΔH_{AX} is the enthalpy for dissociation (i.e., bond energy

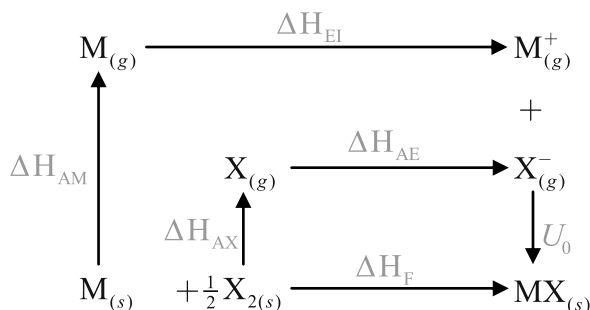

Born–Haber’s cycle — Figure

plus RT) of the diatomic molecule. In the cases of metals evaporated to form monatomic gases, ΔH_{AM} is identical to the sublimation energy. If the sublimation takes place for a diatomic molecule, M_2 , then it is necessary to include the enthalpy of reaction.

Ref.: [i] Huheey JE (1972) *Inorganic chemistry, principles of structure and reactivity*. Harper & Row, New York

MBS

Born–Mayer equation — This equation predicts the lattice energy of crystalline solids [i]. It is based on a simple model, in which the attraction and repulsion for a given arrangement of ions is calculated. The Born–Mayer energy (E_{B-M}) is given by [i]:

$$E_{B-M} = \frac{N_A e^2 A z_A z_B}{4\pi\epsilon_0 d_0} \left(1 - \frac{d^*}{d_0} \right), \quad (1)$$

where ϵ_0 is the \rightarrow permittivity of the vacuum; z_A is the charge of the ions “A”, while z_B is the charge of the ions “B”; e is the \rightarrow elementary electric charge; N_A is the Avogadro constant; A is the Madelung constant (which results from large positive and negative Coulomb interactions); d_0 is the distance between the cations and anions (in Angstroms); d^* is the exponential scaling factor for repulsive term (0.345×10^{-10} m).

Ref.: [i] Born M, Huang K (1954) *Dynamical theory of crystal lattices*. Oxford University Press, Oxford

RG

Born solvation energy \rightarrow Born equation

Boron-doped diamond electrodes — Electrode material made from synthetic diamond (\rightarrow diamond electrode) for example via vapor deposition techniques. In an atmosphere of methane (as a carbon source) and hydrogen (as etchant) at ca. 600 °C diamond seeds tend to grow whereas graphitic carbon deposits are etched

away. As a result thin polycrystalline films of diamond are grown (with a growth rate of ca. 1 to 10 $\mu\text{m h}^{-1}$) directly onto suitable substrates (silicon, niobium, tungsten, etc.). By introducing traces of boron into the gas phase (e.g., B_2H_6 or trimethylborate), effective boron-doping of the diamond is achieved. At a boron-doping level of ca. 10^{20} cm^{-3} a blue-black diamond material with good electrical conductivity and unique electrode characteristics is obtained [i–iii]. At lower doping levels *p*-type \rightarrow *semiconductor* characteristics are observed. The diamond electrode surface is mechanically inert (towards polishing, or cavitation under exposure to ultrasound) and chemically inert (towards aggressive chemicals and under extreme polarization).

Applications of this electrode material include (i) the anodic formation of hydroxyl radicals, (ii) the anodic formation of ozone and peroxy species, (iii) waste degradation in aqueous solution (hazardous and a range of organic wastes have been broken down without toxic intermediates), (iv) as a mechanically robust electrode for solid state electrochemistry or in the presence of power ultrasound, (v) as a dimensionally stable electrode, (vi) as a IR and Vis transparent electrode material, and (vii) as an inert substrate for electro-catalysts.

Refs.: [i] Pleskov YV (2002) *Russ J Electrochem* 38:1275; [ii] Swain GM, Anderson AB, Angus JC (1998) *MRS Bull* 23:56; [iii] Rao TN, Ivan-dini TA, Terashima C, Sarada BV, Fujishima A (2003) *New Diamond Frontier Carbon Technol* 13:79

FM

Böttger, Wilhelm Carl

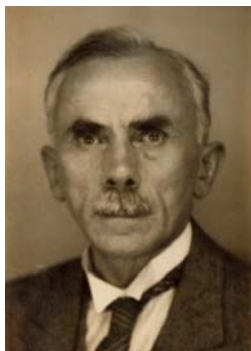

(Universitätsarchiv Leipzig)

(Oct. 2, 1871, Leising, Germany – Oct. 23, 1949, Hannover, Germany) From 1893 to 1895 Böttger studied pharmacy in Leipzig. He continued by studying chemistry in the institute of \rightarrow Ostwald, F.W. and devoted his further work to electrochemistry. His Ph.D. (1897) concerned the “application of the \rightarrow *electrometer* as indicator for acid and base titrations”. Following a one-year assistantship in Göttingen (with Otto Wallach) he returned

to the Ostwald institute and habilitated in 1903 for analytical and physical chemistry. In 1904/05 he was Research Associate at the Institute of Technology, Boston, USA (with A. A. Noyes). In 1910 he became extraordinary Professor at the University of Leipzig and from 1922 until his retirement he was ‘ordentlicher Honorarprofessor’ (full honorary Professor) and chief of the chemical department of the Institute of Physical Chemistry [i]. Three years following the first potentiometric precipitation titration by \rightarrow Behrend, Böttger performed the first potentiometric acid–base titration [ii]. Böttger contributed to the establishment of potentiometric analysis and further development \rightarrow *electrogravimetry* [iii].

Refs.: [i] Brennecke E (1950) *Angew Chem* 62:279; [ii] Böttger W (1897) *Z Physik Chem* 24:253; [iii] Böttger W (1949) *Elektroanalyse. In: Physikalische Methoden der Analytischen Chemie*. Böttger W (ed) 2nd part, Geest & Portig, Leipzig, pp 315

FS

Böttcher’s accumulator — This was an \rightarrow *accumulator* with a lead and a zinc electrode in a zinc sulfate electrolyte. Upon discharge zinc ions are reduced to the metal, and lead is oxidized to lead sulfate. These processes are reversed upon charging.

Ref.: [i] Hauck WP (1883) *Die Galvanischen Batterien, Accumulatoren und Thermosäulen*, 2nd edn. Hartleben’s Verlag, Wien

FS

Boundary layer \rightarrow *hydrodynamic boundary layer*

Boundary value — A boundary value is the value of a parameter in a differential equation at a particular location and/or time. In electrochemistry a boundary value could refer to a concentration or concentration gradient at $x = 0$ and/or $x = \infty$ or to the concentration or to the time derivative of the concentration at $t = \infty$ (for example, the steady-state boundary condition requires that $(dc/dt)_{t=\infty} = 0$). Some examples: $(dc/dx)_{x=0} = 0$ for any species that is not consumed or produced at the electrode surface; $(dc/dx)_{x=0} = -f_{x=0}/D$ where $f_{x=0}$ is the flux of the species, perhaps defined by application of a constant current (\rightarrow *von Neumann boundary condition*) and D is its diffusion coefficient; $c_{x=0}$ is defined by the electrode potential (\rightarrow *Dirichlet boundary condition*); $c_{x=\infty}$, the concentration at $x = \infty$ (commonly referred to as the bulk concentration) is a constant.

SWF

Boxcar averaging \rightarrow *digital filter*

Braun, Ferdinand

(© The Nobel Foundation)

(June 6, 1850, Fulda, Germany – Apr. 20, 1918, Brooklyn, NY, USA) German physicist, Ph.D. 1872. In 1874 Braun discovered the non-ohmic behavior of metal-semiconductor contacts, and in 1878 he disproved the Thompson–Berthelot principle (assumption that the heat of a reaction is the driving force) in studies of the → *Daniell element* [i]. This work was an important impetus for → *Helmholtz* to develop independent of → *Gibbs* the idea of the → *free energy* of a reaction as the driving force. In 1897/98, B. developed the wireless telegraphy for which he was awarded together with Guglielmo Marconi the Nobel Prize in physics in 1909. Braun also invented the cathode ray tube.

Refs.: [i] Braun F (1878) *Wied Ann* 5:182; [ii] <http://nobelprize.org/index.html>

Bravais lattice — used to describe atomic structure of crystalline → *solid materials* [i, ii], is an infinite array of points generated by a set of discrete translation operations, providing the same arrangement and orientation when viewed from any lattice point. A three-dimensional Bravais lattice consists of all points with position vectors \mathbf{R}_L :

$$\mathbf{R}_L = N_1 \cdot \mathbf{w}_1 + N_2 \cdot \mathbf{w}_2 + N_3 \cdot \mathbf{w}_3 ,$$

where the three primitive lattice vectors \mathbf{w}_i are not all in the same plane, and the lattice can be generated varying the integers N_j . The smallest parallelepiped with a lattice point (site) at each corner corresponds to the so-called primitive unit cell. A crystal structure may also be described in terms of non-primitive unit cells, which are larger than the primitive cell. There are 14 possible three-dimensional Bravais lattices. These are named for French physicist Auguste Bravais (1811–1863), who made a great contribution in the crystal lattice theory.

Refs.: [i] West AR (1984) *Solid state chemistry and its applications*. Wiley, Chichester; [ii] Kittel C (1996) *Introduction to solid state physics*, 7th edn. Wiley, Chichester

VK

Brdička, Rudolf

(Feb. 25, 1906, Prague, Austro-Hungarian Empire, now Czech Republic – June 25, 1970, Mariánské Lázně, then Czechoslovakia) Student, assistant, and finally successor of → *Heyrovský* at Charles University in Prague, later director of the Institute of Physical Chemistry, Academy of Sciences, Prague. Introduced polarographic “Brdička reaction” – sensitive → *catalytic current* signal due to evolution of hydrogen at → *mercury electrodes* from cobalt-containing solutions of proteins, used in analysis of proteins and in medical diagnostics, esp. in treatment of cancer [i–ix]. Besides, he studied and expressed quantitatively adsorption of electroactive substances at the electrode [x], and contributed essentially to exact formulation of the effect of chemical reactions in electrode processes [xi–xiii]. Author of a comprehensive textbook of physical chemistry, which was translated into several languages.

Refs.: [i] Brdička R (1933) *Coll Czech Chem Commun* 5:112; [ii] Brdička R (1937) *Nature* 139:1020; [iii] Brdička R (1947) *Research* 1:25; [iv] Brdička R, Březina M, Kalous V (1965) *Talanta* 12:1149; [v] Müller OH (1963) *Polarographic analysis of proteins, amino acids and other compounds by means of Brdička reaction*. In: Glick D (ed) *Methods of biochemical analysis*, vol. II. Interscience, New York, pp 329–403; [vi] Homolka J (1971) *Polarography of proteins, analytical principles and applications in biological and clinical chemistry*. In: Glick D (ed) *Methods in biochemical analysis*, vol. 19. Wiley, New York, pp 436–555; [vii] Hart JP (1990) *Electroanalysis of biologically important compounds*. Ellis Horwood, New York, p 92; [viii] Brabec V, Vetterl V, Vrana O (1996) *Electroanalysis of biomacromolecules*. In: Brabec V, Walz D, Milazzo G (eds) *Techniques in bioelectrochemistry*, vol. 3. Birkhäuser Verlag, Basel, p 287; [ix] Luo D, Lan J, Zhou C, Luo C (2003) *Anal Chem* 75:6346; [x] Brdička R (1942) *Z Elektrochem* 48:278; [xi] Brdička R, Wiesner K (1947) *Coll Czech Chem Commun*

FS

12:138; [xii] Brdička R (1955) *Z Elektrochem* 59:787; [xiii] Brdička R, Hanuš V, Koutecký J (1962) *General theoretical treatment of the polarographic kinetic currents*. In: Zuman P, Kolthoff IM (eds) *Progress in Polarography*, vol. 1. Interscience, New York London, pp 145–199

MHey

Breyer, Bruno Zdenko



(Courtesy of Petr Zuman, USA)

(Nov. 14, 1900, Zábřeh, then Austro-Hungarian Empire, now Czech Republic – Nov. 12, 1967, Milano, Italy) Ph.D. (Bonn), MD (Padua), from 1941 professor of agricultural chemistry, University of Sydney, author of “alternating (or AC) polarography” – i.e., → *polarography* with superimposed alternating voltage of small amplitude, and of “→ *tensammetry*” – i.e., AC polarography of surface-active substances.

Ref.: [i] Breyer B, Bauer HH (1963) *Alternating current polarography and tensammetry*. Interscience, New York

MHey

Bridge, electrical — An electrical bridge is the connection between two points of an electrical network through which no current will pass when the bridge is “balanced”. A number of electrical bridge circuits, i.e., circuits with such connecting bridge, have been developed for the purpose of measuring → *resistance*, → *capacity*, → *impedance*, inductance, etc. The most prominent is the → *Wheatstone bridge*.

FS

Briggs–Haldane conditions → *Michaelis–Menten kinetics*

Brighteners → *electroplating additives*

Brønsted, Johannes Nicolaus



(Feb. 22, 1879, Varde, Denmark – Dec. 17, 1947, Copenhagen, Denmark) Ph.D. Copenhagen 1908, since 1908 Professor of Chemistry (the 3rd chair, i.e., the chair of Physical Chemistry at the Univ. of Copenhagen). 1926/27 visiting Professor at Yale Univ., New Haven, Connecticut, USA. Famous for his work on chemical reaction kinetics, chemical affinity, indicators, and thermodynamics of solutions. He could explain the effect of activity coefficients on reaction rates in solutions. In 1923 he developed independently of → *Lowry*, and → *Bjerrum* a new → *acid-base theory*, the so-called *Brønsted acid-base theory*.

Ref.: [i] Brønsted JN (1923) *Rec Trav Chim Pays-Bas* 42:718

FS

Brønsted acid–base theory → *acid-base theories*

Brønsted–Bjerrum equation — The rate constant k of a chemical reaction involving ionic species A and B may be influenced by other ionic species in solution not directly participating in this reaction (i.e., a dissolved salt, thus the associated observation is called primary salt effect). The change of the rate as a function of the ionic charge of the involved species and the → *ionic strength* of the solution is given by the Brønsted–Bjerrum equation

$$\ln k = \ln k_0 + 1.018z_A z_B I^{1/2}$$

with the rate constant k_0 in the absence of other species; k in the presence of other species, z_A and z_B are the ionic charge of the reacting species, and I is the → *ionic strength*. In case of reactants having charges of equal sign the reaction is accelerated, in case of opposite signs the rate decreases. Reactions involving both neutral and charged reactants show no dependency.

Ref.: [i] Weston RE, Schwarz HA (1972) *Chemical kinetics*. Prentice-Hall, Englewood Cliffs

RH

B

Brønsted's salt effect → Brønsted–Bjerrum equation,
→ charge transfer reaction

Brown–Walker reaction — Important generalization and extension of the Kolbe reaction (1891) (→ Kolbe synthesis) leading to the synthesis of a variety of long-chain dicarboxylic acids and esters using monoesters of dicarboxylic precursors. Among the most used application belongs the production of sebacic acid diethylester from hydrogen ethyladipate

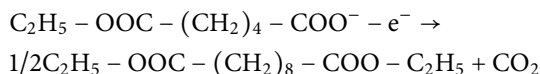

Refs.: [i] Torii S, Tanaka H (1991) *Carboxylic acids*. In: Lund H, Baizer M (eds) *Organic electrochemistry*. Marcel Dekker, New York; [ii] Schaefer HJ (1991) *Electrolytic oxidative coupling*. In: Lund H, Baizer M (eds) *Organic electrochemistry*. Marcel Dekker, New York

Bubble electrodes — Mercury electrodes constructed in such a way that an electrolyte solution is entering a mercury-filled vessel through one or many small orifices in the bottom (cf. Fig. 1). The solution bubbles grow and will finally ascend in the mercury. The counter and the reference electrode have to be situated in the tubing fed to the orifice. Bubble electrodes have been developed as flow-through detectors for HPLC and FIA [i–iii, vi], as electrodes to generate ESR-active species [iii–iv], for → *tensammetry* [vii], and for electrosynthesis [v]. The fact that they are mercury based impeded further developments of this electrode type.

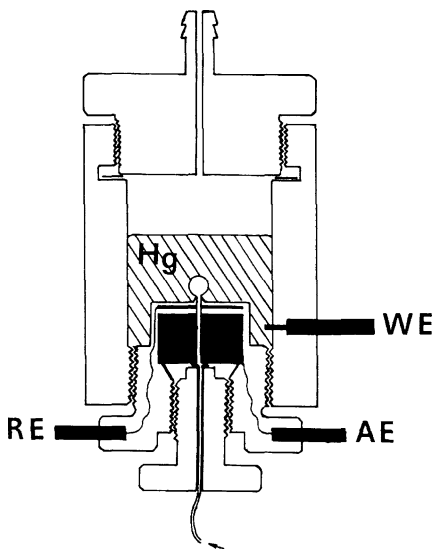

Bubble electrodes — Figure 1. Bubble electrode for analytical measurements (reproduced from [vii])

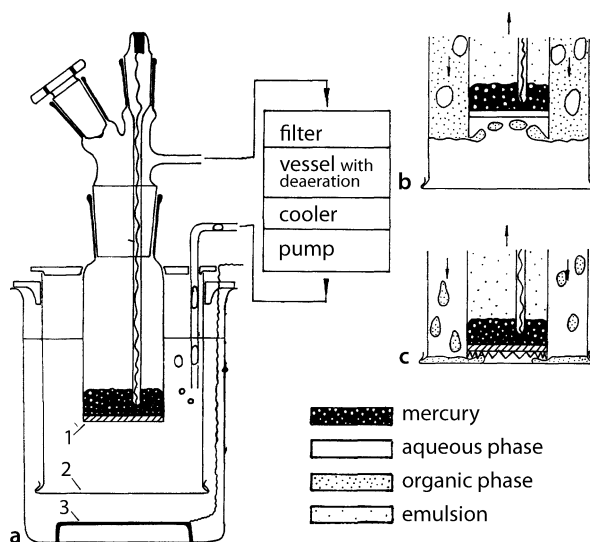

JL

Bubble electrodes — Figure 2. Bubble electrode for electrosynthesis: 1 – bubble electrode, 2 – ion exchange membrane, 3 – PbO₂ anode. Arrangement A is for single-phase operation, and arrangement B and C are for two-phase electrolysis (electrolysis of emulsion) (reproduced from [v])

Refs.: [i] Scholz F, Henrion G (1983) *Z Chem* 23:152; [ii] Trojánek A, Křestan L (1983) *J Liq Chromatog* 6:1759; [iii] Scholz F, Henrion G (1984) *Z Chem* 25:121; [iv] Stöffer R, Scholz F, Pragst F, Henrion G (1985) *Z Chem* 25:157; [v] Pragst F, Scholz F, Woitke P, Kollek V, Henrion G (1985) *J prakt Chem* 327:1028; [vi] Trojánek A (1985) *J Chromatog* 323:406; [vii] Scholz F, Kupfer M, Seelisch J, Glowacz G, Henrion G (1987) *Fresenius Z Anal Chem* 326:774

FS

Buckingham's π-theorem and dimensional analysis — Buckingham's π-theorem [i] predicts the number of → *dimensionless parameters* that are required to characterize a given physical system. A relationship between *m* different physical parameters (e.g., flux, → *diffusion coefficient*, time, concentration) can be expressed in terms of *m*–*n* dimensionless parameters (which Buckingham dubbed “π groups”), where *n* is the total number of fundamental units (such as m, s, mol) required to express the variables. For an electrochemical system with semi-infinite linear geometry involving a diffusion coefficient (*D*, units: cm² s^{–1}), flux at *x* = 0 (*f_{x=0}*, units: moles cm^{–2} s^{–1}), bulk concentration (*c_∞*, units: moles cm^{–3}) and time (*t*, units: s), *m* = 4 (*D*, *f_{x=0}*, *c_∞*, *t*) and *n* = 3 (cm, s, moles). Thus *m* – *n* = 1; therefore only one dimensionless parameter can be constructed and that is *f_{x=0}* (*t/D*)^{1/2}/*c_∞*. Dimensional analysis is a powerful tool for characterizing the behavior of complex physical systems and in many cases can define relationships

without any additional computation (see \rightarrow *dimensional analysis*). For the most economical graphical or tabular representation, parameter correlations should be expressed in terms of the relevant π groups. This will become particularly important when a system's behavior has been quantified using numerical analysis and no analytic mathematical expressions are available. A dimensionless group which can be produced by combination of two or more other dimensionless groups may be more convenient in form for a particular application but is not counted as a new group.

Ref.: [i] Buckingham, E (1914) *Phys. Rev.* 4:345

SWF

Buffer — A solution that, by virtue of containing sufficiently high concentrations of certain species, tends to resist changes in some solution property, such as \rightarrow *pH*, \rightarrow *equilibrium potential*, or \rightarrow *ionic strength*.

DT

pH buffer — A solution containing appreciable concentrations of a conjugate acid/base pair that resists changes in \rightarrow *pH* upon further addition of small amounts of acid or base. Example conjugate acid/base pairs include $\text{CH}_3\text{COOH}/\text{CH}_3\text{COO}^-$, $\text{H}_2\text{PO}_4^-/\text{HPO}_4^{2-}$, and $\text{NH}_4^+/\text{NH}_3$, where the ionic species are typically introduced as salts. An accurate expression relating the pH of the buffer to the \rightarrow *acidity constant* for the conjugate pair ($\text{p}K_a$) and the analytical concentrations of the acid (c_{HB}) and base (c_{B}) forms is given by:

$$\text{pH} = \text{p}K_a + \log \frac{\gamma_{\text{B}}}{\gamma_{\text{HB}}} + \log \frac{c_{\text{B}} + [\text{H}_3\text{O}^+] - [\text{OH}^-]}{c_{\text{HB}} - [\text{H}_3\text{O}^+] + [\text{OH}^-]},$$

where γ_{B} and γ_{HB} are the \rightarrow *activity coefficients* for the base and acid forms and $[X]$ represents the molar concentration of species X . The above expression is often simplified to give the approximate \rightarrow *Henderson-Hasselbalch equation* [i]:

$$\text{pH} \approx \text{p}K_a + \log \frac{c_{\text{B}}}{c_{\text{HB}}}.$$

The buffer capacity β , defined as the moles of acid or base necessary to change the pH of one liter of solution by one unit, is given by

$$\beta = \frac{2.3cK_a10^{-\text{pH}}}{(K_a + 10^{-\text{pH}})^2},$$

where c is the sum of the molar concentrations of the acid and its conjugate base ($c_{\text{HB}} + c_{\text{B}}$) [ii]. The buffer capacity increases with c and is at maximum when $\text{pH} = \text{p}K_a$. The above expressions are approximations for

a conjugate pair formed from a polyprotic system (capable of multiple ionization steps).

DT

ionic strength buffer — Sometimes referred to as an ionic strength adjustment buffer (ISAB), this is a solution that attempts to minimize differences (or changes) in \rightarrow *ionic strength*. \rightarrow *Ion selective electrode* (ISE) measurements often involve standards and samples that have differing ionic strengths. Therefore, the \rightarrow *activity coefficient* (γ) of the target ion (and, hence, the response of the ISE to a given concentration of ion) also differs from standard to standard, from standard to sample, and from sample to sample. To overcome the effect of variable ionic strength, a solution of high ionic strength (which does not contain the ion to be measured or any likely interferent) is added to all standards and samples. This solution (the ISAB) effectively swamps out the ionic effects of the host solutions, resulting in a uniform ionic strength in all standards and samples [iii].

In \rightarrow *voltammetry*, the electrode redox reaction necessarily involves a change in ionic strength near the electrode (i.e., an ion is consumed, produced, or undergoes a change in charge number). Therefore, the activity coefficients of the electroactive species vary as a function of time and distance from the electrode. In this case, the presence of an excess of a \rightarrow *supporting electrolyte* serves as an ionic strength buffer [iv].

DT

redox buffer — A solution containing appreciable concentrations of two species (a \rightarrow *redox couple*) that are rapidly interconvertible by an electron exchange. The interconversion may involve chemical species (e.g., protons) as well as electrons. The equilibrium (redox) potential (E) of the solution is fixed by the ratio of the concentrations of the two species (as given by the \rightarrow *Nernst equation*) and resists change upon further addition of small amounts of oxidant or reductant. By analogy with \rightarrow *pH buffer* capacity, the redox buffer capacity β for a single redox couple involving a one-electron transfer and having \rightarrow *formal potential* $E_c^{\ominus'}$ is given by:

$$\beta = \frac{2.3c10^{-f(E+E_c^{\ominus'})}}{(10^{-fE} + 10^{-fE_c^{\ominus'}})^2},$$

where $f = F/2.3RT$ and c is the sum of the molar concentrations of the two redox species. The buffer capacity increases with c and is a maximum when $E = E_c^{\ominus'}$. Expressions are also available for redox systems involving several one-electron steps or one multielectron step [v].

Refs.: [i] Segal IH (1976) *Biochemical calculations*, 2nd edn. Wiley, New York; [ii] van Slyke DD (1922) *J Biol Chem* 52:525; [iii] Frant MS, Ross

JW Jr (1968) *Anal Chem* 40:1169; [iv] Oldham KB, Myland JC (1994) *Fundamentals of electrochemical science, 1st edn.* Academic Press, San Diego, p 265; [v] de Levie R (1999) *J Chem Educ* 76:574

DT

Bugarszky, István — (May 21, 1868, Zenta, Hungary – March 3, 1941, Budapest, Hungary) Bugarszky received his doctoral diploma in chemistry at the Budapest University in 1891. He was appointed lecturer at the Veterinary College, Budapest and awarded the title of professor of chemistry in 1902. He worked at → *Nernst's* laboratory in Göttingen in 1896. He became a professor at the Budapest University in 1913 where he remained until his retirement in 1935.

His most famous achievement was the discovery of the → *endothermic galvanic cells* in 1897 [i, ii]. It was the first evidence that endothermic reactions can proceed spontaneously. Therefore, it supplied a verification of the concept of → *Gibbs* and → *Helmholtz* regarding the nature of affinity, i.e., the Gibbs free energy of reaction is of importance and not the heat of reaction (enthalpy) as claimed by Pierre Eugène Marcellin Berthelot (1827–1907) and Hans Peter Jørgen Julius Thomsen (1826–1909).

Refs.: [i] Bugarszky I (1897) *Magyar Chem Folyóirat* 3:38, *Z anorg Chem* 14:145; [ii] Nernst W (1926) *Theoretische Chemie.* Stuttgart

Bunsen, Robert Wilhelm



(March 30, 1811, Göttingen, Germany – Aug. 16, 1899, Heidelberg, Germany)¹ Bunsen started his chemistry studies in Göttingen 1828, obtained his Ph.D. in 1831, and habilitation in 1833. In 1836 he became successor of Friedrich Wöhler in Kassel (Germany), was appointed as Professor and Director of the Chemical Institute of Marburg University in 1839, in 1851 he was in Breslau, Germany (now Wrocław, Poland), and from 1852 until 1889 he was Professor at Heidelberg University [i]. At the start of his scientific career he performed some research in the

field of organic chemistry (with cacodyls compounds). Later his activities were most diverse and he contributed to many fields of chemistry: He is one of the founders of gas analysis, and, together with Gustav Kirchhoff, he is the founder of spectral analysis. Together with Kirchhoff he discovered the chemical elements cesium and rubidium. He invented what is now known as the 'Bunsen burner', and also the water suction pump. In electrochemistry he is remembered for two kinds of batteries (→ *Bunsen cell* [ii], and → *Bunsen's chromic acid battery* [iii] developed to produce electric sparks for spectral analysis). He was the first to point out the possibility to use electricity for lighting. Bunsen also pioneered studies in photochemistry (together with H.E. Roscoe). His collected works have been published [iv] and a very detailed memorial lecture given by Henry Roscoe is also available [v].

¹ Most sources wrongly give March 31st as his birthday [i].

Refs.: [i] Lockemann G (1949) *Robert Wilhelm Bunsen – Lebensbild eines deutschen Naturforschers.* In: Frickhinger HW (ed) *Große Naturforscher*, vol. 6. Wissenschaftliche Verlagsgesellschaft, Stuttgart; [ii] Bunsen R (1841) *Annal Chem Pharm* 38:311 (DOI: 10.1002/jlac.18410380306); [iii] Bunsen R (1875) *Pogg Ann Phys* 155:230; [iv] Ostwald W, Bodenstein M (eds) (1904) *Gesammelte Abhandlungen von Robert Bunsen*, 3 vols. Engelmann, Leipzig; [iii] Roscoe H (1901) *Bunsen Memorial Lecture.* In: *Memorial lectures delivered before the Chemical Society 1893–1900.* Gurney and Jackson, London, pp 513

FS

Bunsen cell → *Bunsen* replaced the platinum electrode in the → *Grove cell* by a → *carbon electrode* [i]. The Bunsen battery contained a zinc electrode in sulfuric acid and a carbon electrode in nitric acid. The two electrode compartments were separated by a ceramic pot. Bunsen discovered a way to carbonize a mixture of powdered coke and hard coal by strong heating; thus foreshadowing the later used graphitizing process [ii, iii].

Refs.: [i] Bunsen R (1841) *Annal Chem Pharm* 38:311 (DOI: 10.1002/jlac.18410380306); [ii] Hauck WP (1883) *Die Galvanischen Batterien, Accumulatoren und Thermosäulen*, 2nd edn. Hartleben's Verlag, Wien; [iii] Roscoe H (1901) *Bunsen memorial lecture.* In: *Memorial lectures delivered before the Chemical Society 1893–1900.* Gurney and Jackson, London, pp 513

FS

Bunsen's chromic acid battery → *Bunsen* constructed a → *chromic acid battery* with zinc anodes for the purpose of producing electric sparks for spectral analysis [i]. The electrodes (carbon and zinc) could be immersed in

the electrolyte in a controlled way as to regulate the current [ii–iv].

See also → Daniell cell, → zinc, → Zn^{2+}/Zn electrodes, → $Zn^{2+}/Zn(Hg)$ electrodes, → zinc–air batteries (cell), and → Leclanché cell.

Refs.: [i] Bunsen R (1875) *Pogg Ann Phys* 155:230; [ii] Hauck WP (1883) *Die Galvanischen Batterien, Accumulatoren und Thermosäulen*. 2nd edn. Hartleben's Verlag, Wien; [iii] Pfaundler L (1888–1890) *Müller-Pouillet's Lehrbuch der Physik und Meteorologie*, 9th edn., vol. 3. Vieweg und Sohn, Braunschweig, p 381; [iv] Roscoe H (1901) *Bunsen memorial lecture*. In: *Memorial lectures delivered before the Chemical Society 1893–1900*. Gurney and Jackson, London, pp 513

FS

Burger's vector — is used to characterize dislocations, a very important class of extended → defects in solids. Dislocations are stoichiometric line imperfections, with two extreme cases: edge and screw [i]. An edge dislocation can be visualized as an extra half-plane of atoms, i.e., one plane that only passes a part of the way through a crystal lattice. The center of the distorted region where the extra half-plane terminates, is the so-called line of the dislocation. The Burger's vector is perpendicular to this line; its magnitude corresponds to the distance between the extra and regular planes. A screw dislocation transforms successive atom planes into a helix surface; the Burger's vector has the same physical meaning, but is parallel to the dislocation line. Other forms of dislocations may be constructed from segments of these two extreme forms. As for other extended defects, dislocations may affect mechanical behavior, ion intercalation and transport at low temperatures, grain-growth and texturing in ceramic materials, electronic conduction, and other properties of → solid materials.

Refs.: [i] West AR (1984) *Solid state chemistry and its applications*. Wiley, Chichester; [ii] Bacon DJ, Hull D (1984) *Introduction to dislocations*, 3rd edn. Pergamon, New York

VK

Butler, John Alfred Valentine — (Feb. 14, 1899, Winchcombe, Gloucestershire, England – July 16, 1977). Butler greatly contributed to theoretical electrochemistry, particularly, to connection of electrochemical kinetics and thermodynamics [i, ii]. The famous → Butler–Volmer equation (1924) showing the exponential relation between current and potential was named after him (and → Volmer) [iii–vii]. It should be noted that → Erdey-Grúz (Volmer's student at that time) significantly contributed to this work, but his name is, unfortunately, almost forgotten now. Butler also introduced (along with

→ Gurney) the energy-level thinking into electrochemistry (1951) similarly to → photochemistry [viii].

Refs.: [i] Bockris JO'M, Reddy AKN, Gamboa-Aldeco M (2000) *Modern electrochemistry, fundamentals of electrochemistry*, 2nd ed, vol. 2A. Kluwer, New York, p 1048; [ii] Mayneord WV (1979) *Biographical memoirs of fellows of the Royal Society* 25:144; [iii] Butler JAV (1924) *Trans Faraday Soc* 19:729; [iv] Butler JAV (1924) *Trans Faraday Soc* 19:734; [v] Erdey-Grúz T, Volmer M (1930) *Z phys Chem* 150A:203; [vi] Butler JAV (1935) *The fundamentals of chemical thermodynamics: elementary theory and electrochemistry*, 2nd edn. Macmillan, London; [vii] Delahay P (1965) *Double layer and electrode kinetics*. Interscience, New York, pp 154–159; [viii] Butler JAV (1951) (ed) *Electrical phenomena at interfaces, in chemistry, physics and biology*. Methuen, London

EK

Butler–Volmer equation — The Butler–Volmer or → Erdey-Grúz–Volmer or Butler–Erdey-Grúz–Volmer equation is the fundamental equation of → electrode kinetics that describes the exponential relationship between the → current density and the → electrode potential. Based on this model the → equilibrium electrode potential (or the reversible electrode potential) can also be interpreted.

The seminal paper by Erdey-Grúz and → Volmer appeared in 1930 [i] in that the “hydrogen overpotential” was elucidated by using a kinetic model for the → electrode processes when the → charge transfer step, i.e., the → electrode reaction is the → rate-determining step.

Although such terms as Butler–Volmer equation or Butler–Volmer expression or Butler–Volmer kinetics or Butler–Volmer model are widely used in the literature, see e.g., Refs. [ii–xii], its definition is ambiguous and even the name is questionable in the light of the historical facts [viii, xiii, xiv].

Nevertheless, the most acceptable form of the current–electrode potential equation that may be called Butler–Volmer equation for a one-step, one-electron process ($O + e^- \rightleftharpoons R^-$) is as follows:

$$j = k^\ominus F \left[-c_O(x=0) \exp\left(-\frac{\alpha_c F(E - E_c^\ominus)}{RT}\right) + c_R(x=0) \exp\left(\frac{\alpha_a F(E - E_c^\ominus)}{RT}\right) \right], \quad (1)$$

where j is the → current density, k^\ominus is the standard rate coefficient, F is the → Faraday constant, $c_O(x=0)$ and $c_R(x=0)$ are the concentrations of the oxidized and reduced forms of the species at the site of the reaction (at the electrode surface) taking part in the electron exchange process, respectively, α_a and α_c are the anodic and cathodic → transfer coefficients, respectively, R is the

→ *gas constant*, T is the thermodynamic temperature, E is the electrode potential, and $E_c^{\ominus'}$ is the → *formal potential*.

In the other version of the Butler–Volmer equation the potential term is expressed by using the → *overpotential* (η) and the → *exchange current density* (j_o) instead of E , $E_c^{\ominus'}$, and k^\ominus , respectively:

$$j = j_o \left[-\frac{c_O(x=0)}{c_O^*} \exp\left(-\frac{\alpha_c F \eta}{RT}\right) + \frac{c_R(x=0)}{c_R^*} \exp\left(\frac{\alpha_a F \eta}{RT}\right) \right], \quad (2)$$

where c_O^* and c_R^* are the bulk concentration of the respective species.

The two equations are equivalent and easy to transform Eq. (1) into Eq. (2) by using the appropriate → *Nernst equation*

$$E_c = E_c^{\ominus'} + \frac{RT}{F} \ln \frac{c_O^*}{c_R^*}, \quad (3)$$

the definition of the overpotential

$$\eta = E - E_c \quad (4)$$

and the relationship between the exchange current density and the standard rate coefficient

$$j_o = k^\ominus F c_O^* \exp\left[-\frac{\alpha_c F (E_c - E_c^{\ominus'})}{RT}\right]. \quad (5)$$

If the solution is well stirred and the currents are kept so low that the concentrations at the site of the reactions (at the electrode surface) do not differ substantially from the bulk values, i.e., the difference between c_O^* and $c_O(x=0)$ and c_R^* and $c_R(x=0)$ is less than 10%, Eq. (2) becomes

$$j = j_o \left[\exp\left(-\frac{\alpha_c F \eta}{RT}\right) + \exp\left(\frac{\alpha_a F \eta}{RT}\right) \right]. \quad (6)$$

In many cases Eq. (6) is called the Butler–Volmer equation since it describes the case when the charge-transfer step exclusively determines the rate of the reaction (current), i.e., the rate of mass transport is very high in comparison with the rate of the charge transfer.

It usually happens when the charge transfer step is very sluggish (k^\ominus and j_o are very small), and large → *activation overpotential* is needed to drive the reaction in any direction. In this case, the anodic and cathodic reactions are never simultaneously significant.

This type of kinetics is called → *irreversible* or *quasireversible* in electrochemistry.

It is easy to recognize that a linear → *Tafel plot* can be obtained only in this case. This formalism can also

be applied for more complex reaction mechanisms when the rate-determining step is the charge transfer reaction, e.g., when the overall process involving a change of n electrons, i.e., the → *charge number* of the electrode reaction (n) differs from one. In this case Eq. (6) can be written as follows:

$$j = j_o \left[-\exp\left(-\frac{\alpha_c n F \eta}{RT}\right) + \exp\left(\frac{\alpha_a n F \eta}{RT}\right) \right] \quad (7)$$

and Eqs. (1) and (2) can also be rewritten in a similar manner. A more complicated case is when the order of the reaction with respect of species i (ν_i) differs from unity, i.e., the → *partial currents* are related to a product of $\Pi_i c_i^{\nu_i}$. For this case it is difficult to give a general definition since not all reaction rates can be expressed in this form, e.g., the rate of multistep reaction or reactions involving adsorbed species may not be expressible [xv, xvi]. By using the → *stoichiometric number* (ν) Eq. (6) becomes

$$j = j_o \left[\exp\left(-\frac{\alpha_c F \eta}{\nu RT}\right) + \exp\left[\frac{\alpha_a F \eta}{\nu RT}\right] \right] \quad (8)$$

and $j_o = (n/\nu) F k^\ominus \Pi_i c_i^{\nu_i}$ where $\nu_i = \alpha_c \nu_{i,a} + \alpha_a \nu_{i,c}$.

When reactants or intermediates are adsorbed, the rate of the reaction may no longer be related to the concentration by a simple law. This situation is best understood where a reactant is nonspecifically adsorbed in the outer → *Helmholtz plane*. The effect of such adsorption on the electrode kinetics is usually termed the → *Frumkin effect*. Physical and chemical adsorption on the electrode surface is usually described by means of an → *adsorption isotherm* and kinetic equations compatible with various isotherms such as the → *Langmuir*, → *Temkin*, → *Frumkin isotherms* are known.

Refs.: [i] Erdey-Grúz T, Volmer M (1930) *Z phys Chem* A150:203; [ii] Bard AJ, Faulkner LR (2001) *Electrochemical methods*. 2nd edn. Wiley, New York, pp 87–135; [iii] Inzelt G (2002) *Kinetics of electrochemical reactions*. In: Scholz F (ed) *Electroanalytical methods*. Springer, Berlin, pp 29–49; [iv] Brett CMA, Oliveira Brett AM (1993) *Electrochemistry*. Oxford University Press, Oxford, pp 70–81, 104–105; [v] Bockris JO'M, Razumney GA (1967) *Electrocrystallization*. Plenum, New York, p 11; [vi] Bockris JO'M, Reddy AKN (1970) *Modern electrochemistry*. Plenum, New York; [vii] Bockris JO'M, Rand DAJ, Welch BJ (1977) *Trends in electrochemistry*. Plenum, New York, p 10; [viii] Bockris JO'M, Khan SUM (1993) *Surface electrochemistry*. Plenum, New York, pp 213–215; [ix] Christensen PA, Hamnett A (1994) *Techniques and mechanism in electrochemistry*. Blackie Academic & Professional, London, pp 16–18; [x] Oldham KB, Myland JC (1994) *Fundamentals of electrochemical science*. Academic Press, San Diego, pp 167–186; [xi] Hamann CH, Hamnett A, Vielstich W (1998) *Electrochemistry*. Wiley-VCH, Weinheim, pp 152–168; [xii] Rieger PH (1994) *Electrochemistry*. Chapman & Hall, New

Butyronitrile — Table. Comparison of low-temperature electrochemical solvent systems employing NBu_4ClO_4 electrolyte [ii]

Solvent system	Temperature threshold for electrochemical experiments/ $^{\circ}\text{C}$
butyronitrile	-105
69 wt % butyronitrile/31 wt % propionitrile	-118
50 wt % butyronitrile/50 wt % ethylbromide	-145
33 wt % butyronitrile/33 wt % ethylbromide/ 17 wt % isopentane/17 wt % methylcyclopentane	-158
50 wt % butyronitrile/50 wt % ethylchloride	-185

York, p 318; [xiii] Erdey-Grúz T (1972) *Kinetics of electrode processes*. Akadémiai Kiadó, Budapest, pp 22–79, 150–202; [xiv] De Levie R (2000) *J Chem Educ* 77:610; [xv] Parsons R (1974) *Manual of symbols and terminology for physicochemical quantities and units, Appendix III. Electrochemical nomenclature*. *Pure Appl Chem* 37:503; [xvi] Parsons R (1979) *Pure Appl Chem* 52:233

Button cell — Type of button-shaped cell construction most frequently employed with small cells as used in

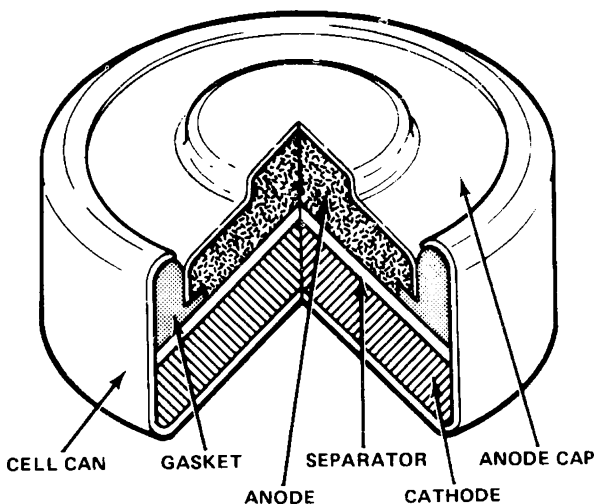

Button cell — Figure. Schematic design of a button cell (alkali-manganese type)

watches, hearing-aid devices, and other small electronic appliances.

RH

Butyronitrile — Propyl cyanide, $(\text{CH}_3\text{CH}_2\text{CH}_2\text{CN})$, organic solvent, melting point $-112\text{ }^{\circ}\text{C}$, boiling point $117.5\text{ }^{\circ}\text{C}$ with a density $(0.795\text{ g cm}^{-3}$ at $15\text{ }^{\circ}\text{C}$) lighter than water and somewhat soluble in water (3 g in 100 cm^3 water at $25\text{ }^{\circ}\text{C}$). Butyronitrile is readily purified and dried over neutral activated alumina or molecular sieves similar to acetonitrile [i]. Due to its low melting point, butyronitrile is an excellent solvent for low temperature studies [ii]. Solvent mixtures containing butyronitrile can be employed to reach extremely low temperatures.

GI

Refs.: [i] Reichardt C (2003) *Solvents and solvent effects in organic chemistry*. Wiley-VCH, Weinheim; [ii] McDevitt, Ching S, Sullivan M, Murray RW (1989) *J Am Chem Soc* 111:4528

FM

Byrne cell — This was a chromic acid–zinc \rightarrow battery where the inert electrode was made from copper with a lead coverage on which the platinum electrode was soldered. The copper and lead base was used to reduce the resistance of the, usually, thin platinum wires.

See also \rightarrow chromic acid battery, \rightarrow Daniell cell, \rightarrow zinc, \rightarrow Zn^{2+}/Zn electrodes, \rightarrow $\text{Zn}^{2+}/\text{Zn}(\text{Hg})$ electrodes, \rightarrow zinc–air batteries (cell), and \rightarrow Leclanché cell.

Ref.: [i] Hauck WP (1883) *Die Galvanischen Batterien, Accumulatoren und Thermosäulen*, 2nd edn. Hartleben's Verlag, Wien

FS

C

Cadmium cell → *Weston normal element*

Cadmium telluride — A II–IV compound → *semiconductor* frequently employed in infrared systems (active component in infrared detectors) and → *photovoltaic devices*. Electrochemical → *passivation* has been employed to improve surface recombination behavior.

Refs.: [i] Wei C, Mishra KK, Rajeshwar K (1992) *Chem Mater* 4:77; [ii] Lemasson P (1989) *J Phys D: Appl Phys* 22:952; [iii] Forni F, Innocenti M, Pezzatini G, Foresti ML (2000) *Electrochim Acta* 45:3225

RH

Calibration — A set of operations that establishes, under specified conditions, a suitable relationship between values of quantities indicated by the measuring system, and the corresponding values realized by standards [i]. The measuring system can involve a simple volumetric flask [ii] or sophisticated instrumental techniques [iii]. Most instrumental methods of analysis are relative since they register a signal due to some physical property of the → *analyte*. Spectrometers, for example, measure the fraction of electromagnetic radiation that is absorbed from a light source by the sample. This fraction must be related to the analyte concentration by its comparison against the fraction of light absorbed by a known concentration of the analyte.

Refs.: [i] McNaught AD, Wilkinson A (1997) *IUPAC compendium of chemical terminology*, 2nd edn. Blackwell Scientific Publications, Oxford; [ii] Day RA, Underwood AL (1991) *Quantitative analysis*. Prentice Hall, New Jersey; [iii] Willard HH, Merritt LL, Dean JA, Settle FA (1988) *Instrumental methods of analysis*. Wadsworth, California

FG

Callan cell — This was a → *Grove battery* where a platinized lead electrode was used instead of the platinized platinum electrode.

Ref.: [i] Hauck WP (1883) *Die Galvanischen Batterien, Accumulatoren und Thermosäulen*, 2nd edn. Hartleben's Verlag, Wien

FS

Callaud cell — This was a variant of the → *Daniell cell*. See also → *zinc*, → *Zn²⁺/Zn electrodes*, → *Zn²⁺/Zn(Hg) electrodes*, → *zinc-air batteries (cell)*, and → *Leclanché cell*.

Ref.: [i] Hauck WP (1883) *Die Galvanischen Batterien, Accumulatoren und Thermosäulen*, 2nd edn. Hartleben's Verlag, Wien

FS

Calomel electrode — is an → *electrode of the second kind*. It was introduced in 1890 by → *Ostwald, F.W.* As a → *reference electrode* of fixed, well-known, and very reproducible → *potential*, it is still a commonly used reference electrode in electrochemistry [i–iii]. It consists of mercury, sparingly soluble mercurous chloride (calomel), and a chloride-containing solution. The electrode net reaction can be formulated in the following way:

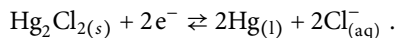

The potential of the electrode against the → *standard hydrogen electrode* is given by the equation:

$$E = E_{c(\text{Hg}_2\text{Cl}_2, \text{Hg})}^{\ominus'} - \frac{RT}{F} \ln a_{\text{Cl}^-}$$

where $E_{c(\text{Hg}_2\text{Cl}_2, \text{Hg})}^{\ominus'}$ is the → *formal potential* of the calomel electrode (0.26816 V at 25 °C) taking into account the → *standard potential* $E_{(\text{Hg}/\text{Hg}_2^{2+})}^{\ominus}$ and the → *solubility product* of calomel, $K_{\text{Hg}_2\text{Cl}_2}$ according to $E_{c(\text{Hg}_2\text{Cl}_2, \text{Hg})}^{\ominus'} = E_{(\text{Hg}/\text{Hg}_2^{2+})}^{\ominus} + \frac{RT}{2F} \ln K_{\text{Hg}_2\text{Cl}_2}$, R is the → *gas constant*, T is the absolute temperature, F is the → *Faraday constant*, and a_{Cl^-} is the → *activity* of the chloride ions. Commonly, saturated potassium chloride solution is used, however, sodium chloride is advisable to apply when working with perchlorate-containing media. Principles, preparation, and potentials at different temperatures have been given in monographs.

At 25 °C the experimentally determined potential of the **KCl-saturated calomel electrode** (SCE) is 0.2444 V vs → *standard hydrogen electrode* (SHE) when the liquid junction potential between the KCl saturated solution and a buffer solution is taken into account [i]. Without the liquid junction potential that value is 0.2412 V vs SHE [i].

Refs.: [i] Ives DJG, Janz GJ (1961) *Reference electrodes, theory and practice*. Academic Press, New York; [ii] Zhang XN (1993) *Reference electrodes*. In: Yu TR, Ji GL (eds) *Electrochemical methods in soil and water research*. Pergamon Press, Oxford, pp 73–81; [iii] Kahlert H (2005) *Reference electrodes*. In: Scholz F (ed) *Electroanalytical methods*. Springer, Berlin, pp 264–266

HK

Camacho cell — This was a → *chromic acid battery* with zinc anodes, and a construction that the chromic acid solutions flowed through the cathode compartment housing the inert carbon electrodes. See also → *Daniell cell*, → *zinc*, → *Zn²⁺/Zn electrodes*, → *Zn²⁺/Zn(Hg) electrodes*, → *zinc-air batteries (cell)*, and → *Leclanché cell*.

Ref.: [i] Hauck WP (1883) *Die Galvanischen Batterien, Accumulatoren und Thermosäulen*, 2nd edn. Hartleben's Verlag, Wien

FS

Candido cell — This was a variant of the → *Daniell cell*. See also → *zinc*, → *Zn²⁺/Zn electrodes*, → *Zn²⁺/Zn(Hg) electrodes*, → *zinc-air batteries (cell)*, and → *Leclanché cell*.

Refs.: [i] Hauck WP (1883) *Die Galvanischen Batterien, Accumulatoren und Thermosäulen*, 2nd edn. Hartleben's Verlag, Wien

FS

Capacitance — Symbol: *C*, unit: farad *F* ($\text{CV}^{-1} = \text{A s V}^{-1}$, in SI base units $\text{m}^{-2} \text{kg}^{-1} \text{s}^4 \text{A}^2$). Measure of the capability of a → *capacitor* to store electrical charge at a potential difference ΔU (voltage) between the two plates of the device:

$$C = \frac{Q}{\Delta U} .$$

RH

Capacitance, stray — is the undesired and unintentional → *capacitance* parts of an experimental setup or instrument, as, e.g., an electrical conducting wire and the chassis.

FS

Capacitive current → *charging current*

Capacitive deionization — In capacitive deionization, water flows between parallel pairs of porous → *carbon electrodes* (such as carbon aerogel electrodes) that are maintained at a potential difference greater than 1.0 V. Ions (and other charged particles such as colloids and microorganisms) become electrostatically immobilized on the charged surfaces, thus allowing pure water to pass through. When the electrodes are fully coated, they are regenerated simply by removing the potential difference, thus allowing the charged impurities to flow away.

Refs.: [i] Tran TD, Farmer JC, Murguia L (2001) *Method and apparatus for capacitive deionization, electrochemical purification, and regeneration of electrodes*. US 5,954,937; [ii] Farmer JC, Fix DV, Mack GV, Pekala RW, Poco JF (1996) *J Electrochem Soc* 143:159

SF

Capacitor

(a) The physical phenomenon:

If a point-shaped object or a conducting sphere with the → *potential* *E* carries a → *charge* *Q*, its → *capacity* *C* is defined as $C = Q/E$. The capacity of a sphere in vacuum with the radius *r* is given by

$$C = 4\pi\epsilon_0 r$$

with the → *dielectric constant* ϵ_0 . *C* is measured in *F* (farad), $1 \text{ F} = 1 \text{ C V}^{-1} = 1 \text{ C}^2 \text{ s}^2 \text{ kg}^{-1} \text{ m}^{-2}$. More relevant for electrochemical environments is the separation of two conducting phases (ionic or electronic conductors, e.g., electrolyte and metal) by an insulating layer (e.g., adsorbate or passive layer). Then an insulating layer with a constant thickness *d* is formally the dielectric of a parallel plate capacitor with a capacity

$$C' = A\epsilon\epsilon_0/d ,$$

where ϵ is the relative dielectric number (the → *permittivity*) of the insulator and *A* is the corresponding area. The capacity is usually normalized to the area *A*:

$$C = C'/A = \epsilon\epsilon_0/d .$$

The dimension of *C* is now F m^{-2} .

(b) The electronic device:

Capacitors are used to store electric energy, especially for shorter periods of time, and substitute → *batteries* in some cases. They smooth the output of full or half-wave rectifiers in power supplies or are part of electric frequency → *filters*.

Capacitors can be polarized or non-polarized, depending on the → *dielectric*. Non-polarized devices have dielectrics consisting of ceramics or polymers (such as polystyrene, polyester, or polypropylene). They are normally box-shaped and their capacity is usually in the range from pF to μF , the maximum voltage up to 1000 V. Polarized capacitors are electrochemical devices; the dielectric is an anodic oxide of Al (μF to 100 mF, potentials up to 1000 V), Ta (capacities μF to 100 μF , potentials up to 20 V), or Nb (→ *electrolytic capacitor*) or a double layer (→ *supercapacitor*, capacities up to some 10 F and potentials up to 2.5 V or 5 V). Aluminum electrolytic capacitors are normally of cylindrical shape with radial or axial leads. Tantalum capacitors are of spherical shape and super capacitors form flat cylinders.

MML

Capacity → *capacitance*, and → *capacitor*.

Capacity (of batteries) — The total amount of → *charge* stored in a cell or a → *battery*, which can be withdrawn under specified discharge conditions, and commonly

expressed in terms of ampere-hours. This term pertains both for primary and secondary batteries. In the latter case, the term relates to the capacity of a fully charged battery.

See also → *charge capacity of a battery*.

Refs.: [i] Linden D (1994) *Basic concepts*. In: Linden D (ed) *Handbook of batteries*, 2nd edn. McGraw-Hill, New York, p 1.8 and Appendix A, p A1; [ii] Nagy Z (ed) (2005) *Online electrochemistry dictionary*. <http://electrochem.cwru.edu/ed/dict.htm>

YG

Practical (actual) capacity — The amount of electricity (→ *charge*), usually expressed in Ah, that can be withdrawn from a → *battery* at specific discharge conditions. Contrary to theoretical capacity and theoretical capacity of a practical battery, the practical capacity of a battery is a measured quantity, and intrinsically incorporates all the losses to the theoretical capacity due to the mass of the nonactive components of the cell, and the electrochemical and chemical limitations of the electrochemical system. The practical capacity of a cell is exceedingly dependent on the measurement conditions, e.g., temperature, → *cut-off voltage*, → *discharge rate*, etc. Refs.: [i] Linden D (1994) *Factors affecting battery performance*. In: Linden D (ed) *Handbook of batteries*, 2nd edn. McGraw-Hill, New York, p 3.3; [ii] Nazri GA, Julien C (1994) *Solid state batteries: Materials, design and optimization*. Kluwer, Dordrecht, p 6

YG

Theoretical capacity of a practical battery —

The calculated maximum amount of → *charge* (in Ah kg⁻¹) that can be withdrawn from a → *battery* based on its theoretical capacity, and the minimum necessary nonactive components, i.e., electrolyte, separator, current-collectors, container, etc. Obviously, the theoretical capacity of a practical battery is considerably lower than its theoretical capacity, and is higher than the actual capacity.

Refs.: [i] Linden D (1994) *Factors affecting battery performance*. In: Linden D (ed) *Handbook of batteries*, 2nd edn. McGraw-Hill, New York, p 3.3; [ii] Nazri GA, Julien C (1994) *Solid state batteries: Materials, design and optimization*. Kluwer, Dordrecht, p 6

YG

Theoretical capacity — A calculated amount of electricity (→ *charge*) involved in a specific electrochemical reaction (expressed for → *battery* → *discharge*), and usually expressed in terms of → *ampere-hours* per kg or → *coulombs* per kg. The theoretical capacity for one gram-equivalent weight of material amounts to 96,487 C (see → *Faraday constant*) or 26.8 Ah. The general expression for the calculation of the theoretical capacity (in Ah kg⁻¹) for a given → *anode* material and → *cathode* material and their combination as full cell is given by

$C_s^{\text{th}} = \frac{nF}{M}$, in which n is the number of → *electrons* involved in the electrochemical reaction, M is the molecular weight of the electroactive materials, and F stands for the → *Faraday constant*. In calculating the theoretical capacity for a battery, only the cathode and anode material masses are taken into consideration, ignoring the → *electrolyte*, separator (see → *diaphragm*), current-collectors, container, etc.

Refs.: [i] Linden D (1994) *Basic concepts*. In: Linden D (ed) *Handbook of batteries*, 2nd edn. McGraw-Hill, New York, p 1.8 and Appendix A, p A.1; [ii] Nagy Z (ed) (2005) *Online electrochemistry dictionary*. <http://electrochem.cwru.edu/ed/dict.htm>; [iii] Hamann CH, Hamnett A, Vielstich W (2004) *Electrochemistry*. Wiley-VCH, Weinheim, p 343

YG

Capacity fading — Loss of faradaic → *capacity* of the → *active mass* in a → *secondary battery*, i.e., reduction of the amount of electric charge which can be stored and retrieved. Numerous causes depending on the type of secondary battery may be effective; mechanical disintegration, loss of electrical contact between particles constituting the active mass, changes in chemical composition, and partial dissolution are only a few.

RH

Capacity intermittent titration technique (CITT) — is a method to assess the chemical → *diffusion coefficient* of potential-determining species intercalated in or deintercalated from an → *insertion electrode*, using consequent galvanostatic and potentiostatic measurement steps in relatively narrow potential ranges. The measurement step includes galvanostatic charging/discharging until a certain → *electrode potential* is achieved, with subsequent potentiostatic process until the → *current* becomes equal to zero. The analysis based on second → *Fick's law*, requires obtaining experimentally the charging/discharging capacity vs. → *voltage* and the voltage vs. time dependencies for electrode with a definite geometry. Typical assumptions are that the (i) powdered electrode consists of ideally spherical particles having equal diameter, (ii) the times are relatively short, (iii) the diffusion coefficient under the given conditions is independent of → *concentration*, and (iv) the effects of electronic transport in the electrode, mass-transport in the → *electrolyte*, and insertion reaction kinetics are all negligible. When these conditions are observed, the calculations can be performed by the equation

$$q = \frac{R^2}{15\bar{D}t_G} - \frac{2R^2}{3\bar{D}t_G} \sum_{j=1}^{\infty} \frac{1}{\alpha_j^2} \exp\left(-\frac{\alpha_j^2 \bar{D}t_G}{R^2}\right),$$

where q is the ratio of charging/discharging capacities in the potentiostatic and galvanostatic steps, R is the particle radius, \bar{D} is the chemical diffusion coefficient, t_G is the duration of the galvanostatic step, and α_j is a constant.

See also: → *ambipolar conductivity*, → *diffusion: determination in solids*, → *Wagner factor*, → *insertion electrodes*, → *batteries*.

Refs.: [i] Tang XC, Song XW, Shen PZ, Jia DZ (2005) *Electrochim Acta* 50:5581; [ii] Tang XC, Pan CY, He LP, Li LQ, Chen ZZ (2004) *Electrochim Acta* 49:3113

XCT

Capenhurst electrolytic etchant regeneration process → *CEER process*

Capillarity — (a) as a branch of science, it concerns the thermodynamics of surfaces and → *interfaces*. It is of utmost importance for → *electrochemistry*, e.g., treating the electrode|solution interface (→ *electrode*, → *solution*), and it extends to several other branches of physics, chemistry, and technical sciences [i]. The thermodynamic theory of capillarity goes back to the work of → *Gibbs*. (b) In a practical sense ‘capillarity’ means the rise or fall of a liquid column in a capillary caused by the interplay of gravity and → *interfacial tension* and also phenomena like capillary condensation [ii].

See also → *adhesion*, → *Dupré equation*, → *Lippmann equation*, → *Lippmann capillary electrometer*, → *point of zero charge*, → *Young equation*.

Refs.: [i] Goodrich FC, Rusanov AI (eds) (1981) *The modern theory of capillarity*. Akademie-Verlag, Berlin; [ii] Hunter RJ (2004) *Foundations of colloid science*. Oxford University Press, Oxford, pp 84

FS

Capillary affinity electrophoresis (CAE) or affinity capillary electrophoresis (ACE) — An electrophoretic separation technique (→ *electrophoresis*), in which → *analytes* are separated in a capillary, with the → *supporting (background) electrolyte* containing substances capable of specific, often biospecific, interactions with the analytes.

Ref.: [i] Riekkola ML, Jönsson JÅ, Smith RM (2004) *Pure Appl Chem* 76:443

WK

Capillary based microcells — Capillary based microcells are used for electrochemical surface analysis or surface modification in the μm range. Capillaries made from glass, plastics, or metal are filled with electrolyte and used to address well-defined, minute areas of a sample by the tip. The tip determines the spatial resolution; typical

diameters vary from 1 μm to some 100 μm , which corresponds to accessed areas in the range from 10^{-8} cm^2 to 10^{-3} cm^2 . The capillaries electrolyte channel is an electric connection of low resistance to another electrode system, e.g., → *counter electrode* and → *reference electrodes*, while the glass wall insulates the system from the environment. The capillaries can be used at single positions or as scanning probes. The complete range of common 2- or 3-electrode techniques is covered: potential measurement, potentiostatic control, transients such as pulse and sweep techniques, or → *impedance spectroscopy*. Local current densities in the range from pA cm^{-2} to some 100 A cm^{-2} are possible. The figure shows a schematic of applications of capillaries: (a) a reference electrode for local potential measurements in the electrolyte, (b) an electrolyte droplet on the investigated surface, addressed by a capillary, (c) a micro → *ion-sensitive electrode* for local analysis of electrolyte composition, (d) local electrochemical analysis with a free droplet, simply held by surface tension, (e) similar concept, but a metal capillary serves as counter electrode, (f) the wetted sample area is well defined by a silicone rubber gasket at the capillary’s mouth, (g) a twin-barreled capillary enables electrolyte flow to remove products, (h) the surface is stimulated by a jet flow, or (i) particle impact. Further applications such as stimulation by friction, light, and more complex applications such as concentration measurements, pH control, and microreactors have been realized.

Refs.: [i] Böhni H, Suter T, Schreyer A (1994) *Electrochim Acta* 40:1361; [ii] Hassel AW, Lohrengel MM (1997) *Electrochim Acta* 42:3327; [iii] Suter T, Böhni H (2001) *Electrochim Acta* 47:191; [iv] Lohrengel MM, Moehring A (2002) In: Schultze JW, Osaka T, Datta M (eds) *New trends in electrochemical technologies. Electrochemical microsystem technologies*, vol. 2. Taylor & Francis, Andover, p 104; [v] Lohrengel MM, Moehring A, Pilaski M (2004) *Electrochim Acta* 47:137; [vi] Lohrengel MM (2004) *Corr Engin Sci Technol* 39:53

MML

Capillary electrochromatography (CEC) — A special case of capillary liquid chromatography, in which the mobile phase motion is driven by → *electroosmotic volume flow* through a capillary, filled, packed, or coated with a stationary phase, (which may be assisted by pressure). The retention time is determined by a combination of → *electrophoretic mobility* and chromatographic retention.

Refs.: [i] Riekkola ML, Jönsson JÅ, Smith RM (2004) *Pure Appl Chem* 76:443; [ii] Bartle KD, Myers P (eds) (2001) *Capillary electrochromatography (Chromatography Monographs)*. Royal Society of Chemistry, London; [iii] Krull IS, Stevenson RL, Mistry K, Swartz ME (2000) *Capillary*

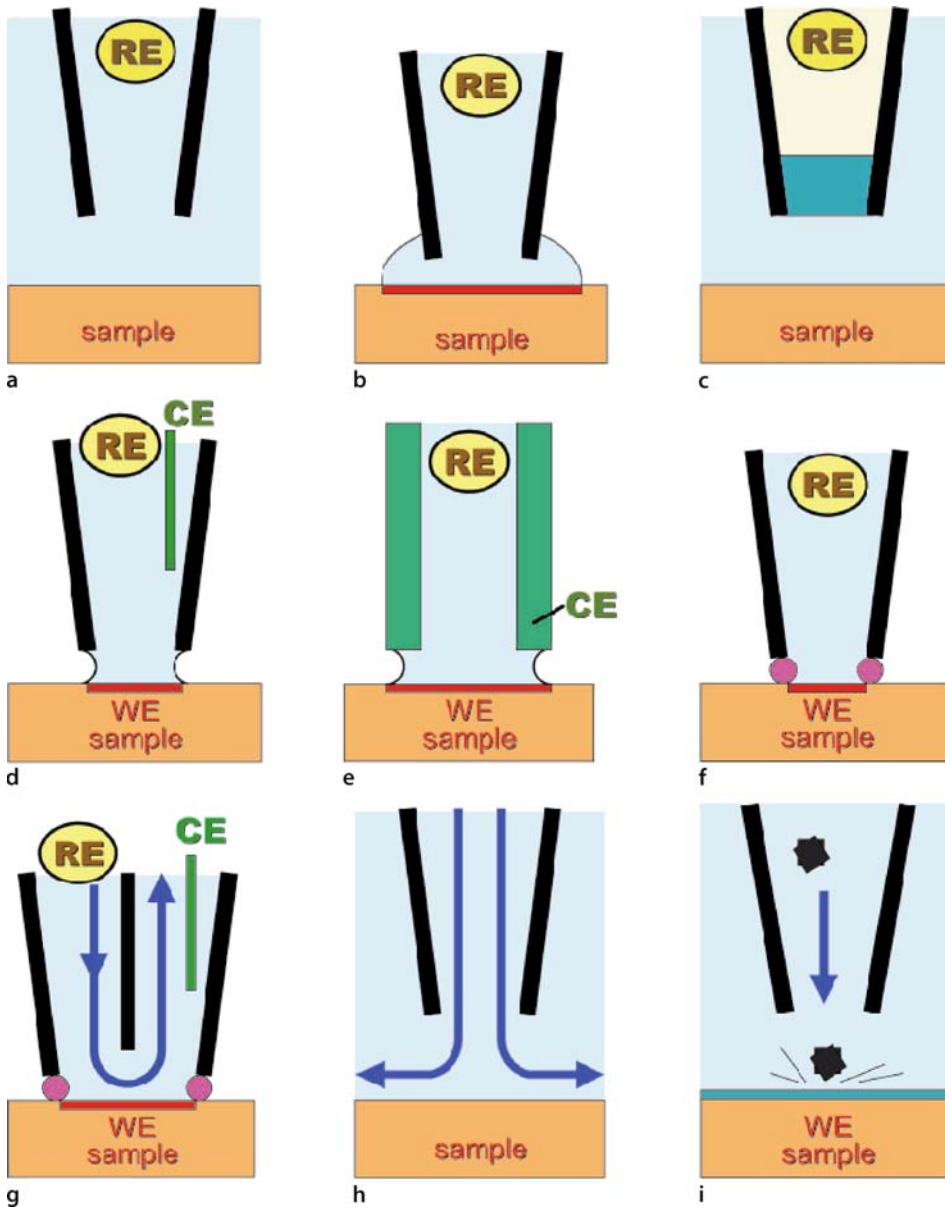

Capillary based microcells — Figure

electrochromatography and pressurized flow capillary electrochromatography. HMB Publishing, New York

WK

Capillary electrometer → Lippmann capillary electrometer

Capillary electromigration techniques — Flow analytical techniques in which analytes are separated in narrow capillaries by employing high → electric field

strength. They include → capillary electrophoresis techniques and electrically driven capillary chromatographic techniques, based on different separation principles.

Ref.: [i] Riekkola ML, Jönsson JÅ, Smith RM (2004) Pure Appl Chem 76:443

WK

Capillary electrophoresis (CE) or capillary zone electrophoresis (CZE) — A capillary electrophoretic separation technique solely based on the differences in the

→ *electrophoretic mobilities* of charged species (analytes) either in aqueous or non-aqueous → *supporting (background) electrolyte* solutions. These can contain additives, which can interact with the analytes and alter their → *electrophoretic mobility*.

Ref.: [i] Riekkola ML, Jönsson JÅ, Smith RM (2004) *Pure Appl Chem* 76:443

Capillary gap cell — The undivided capillary gap (or disc-stack) cell design is frequently used in industrial-scale electroorganic syntheses, but is also applicable for laboratory-scale experiments when a large space-time yield is required. Only the top and bottom electrodes of c.g.c. (see Figure) are electrically connected to → *anode* and → *cathode*, respectively, whereas the other electrodes are polarized in the electrical field and act as → *bipolar electrodes*. This makes c.g.c.'s appropriate for dual electrosynthesis, i.e., product-generating on both electrodes.

Thin plastic strips, mostly of PTFE, of 0.3 to 0.5 mm thickness act as spacers between the electrodes. The latter usually consist of circular graphite plates. The reactant/electrolyte flows through the central channel, and from there radially outward through the gaps, recombining in the upper cell part. The small electrode

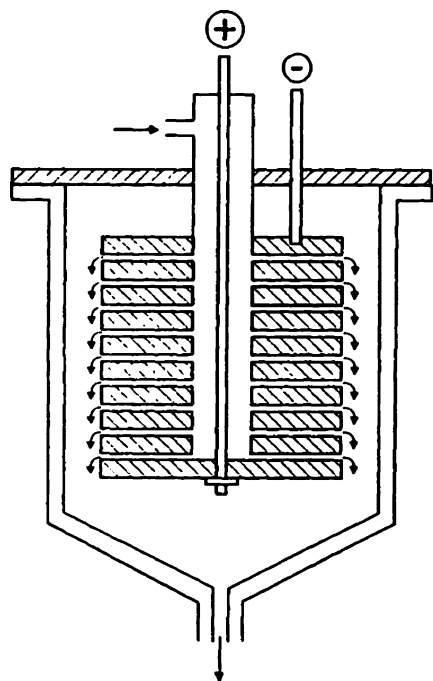

Capillary gap cell — Figure

distance between the electrode plates enables the application of low-conductive electrolytes. C.g.c. design can be modified for solid polymer electrolyte technology, i.e., graphite felt electrodes (→ *carbon electrodes*, subentry → *carbon felt electrode*) separated by ion-exchange membranes or diaphragms only (instead of plates and gaps), are utilized.

WK Refs.: [i] Steckhan E (1996) *Electroorganic synthesis*. In: Kissinger PT, Heineman WR (eds) *Laboratory techniques in analytical chemistry*, 2nd edn. Marcel Dekker, New York, pp. 641–682; [ii] Jörissen J (2004) *Practical aspects of preparative scale electrolysis*. In: Bard AJ, Stratmann M, Schäfer HJ (eds) *Organic electrochemistry. Encyclopedia of electrochemistry*, vol. 8. Wiley-VCH, Weinheim, pp 29

MHer

Capillary gel electrophoresis (CGE) — A special case of → *capillary sieving electrophoresis* in which the capillary is filled with a cross-linked gel.

Ref.: [i] Riekkola ML, Jönsson JÅ, Smith RM (2004) *Pure Appl Chem* 76:443

WK

Capillary isoelectric focusing (CIEF) — An electrophoretic separation technique (→ *electrophoresis*) for the separation of amphoteric analytes (→ *ampholyte*) according to their → *isoelectric points* by the application of an electric field along a pH gradient formed in a capillary.

Ref.: [i] Riekkola ML, Jönsson JÅ, Smith RM (2004) *Pure Appl Chem* 76:443

WK

Capillary isotachopheresis (CITP) — An electrophoretic separation technique (→ *electrophoresis*) in a discontinuous → *buffer system*, in which the analytes migrate according to their → *electrophoretic mobilities*, forming a chain of adjacent zones moving with equal velocity between two solutions, i.e., leading and terminating electrolyte, which bracket the mobility range of the analytes.

Ref.: [i] Riekkola ML, Jönsson JÅ, Smith RM (2004) *Pure Appl Chem* 76:443

WK

Capillary sieving electrophoresis (CSE) — An → *electrophoresis* technique, in which analytes are separated in a capillary, containing a sieving medium (e.g., an entangled polymer network) in the → *supporting (background) electrolyte*. The separation is based on differences in size and shape of the charged analytes.

Ref.: [i] Riekkola ML, Jönsson JÅ, Smith RM (2004) *Pure Appl Chem* 76:443

WK

Capillary waves — Capillary waves are triggered by thermal fluctuation and recovered by \rightarrow surface tension on an \rightarrow interface between liquid phases rather than by gravity [i]. They propagate along the interface [ii], and they distort the sharp boundary at immiscible oil|water interfaces. The frequency of capillary waves, which has been determined with light scattering measurements [iii, iv], is predicted to evaluate time-dependent local surface tensions without any contact with the surface.

Refs.: [i] Levich VG (1962) *Physicochemical hydrodynamics*. Prentice-Hall, Englewood Cliffs, p 591; [ii] Adamson AW (1976) *Physical chemistry of surface*, 3rd edn. Wiley, New York, pp 179–182; [iii] Byrne D, Earnshaw JC (1979) *J Phys D* 12:1133; [iv] Hård S, Hammerius Y, Nilsson O (1976) *J Appl Phys* 47:2433

Carbon — Carbon atoms have 4 unpaired electrons and therefore readily form covalently linked chains, networks, and structures. Carbon sublimates at ca. 4000 °C and forms a liquid only under extremely high pressures. The element carbon exists in several allotropic forms, i.e., diamond, graphite, the \rightarrow fullerenes, and a number of specific materials, as active carbon(s) (charcoal(s)), carbon blacks, pyrolytic carbon, glassy carbon, graphite fibers, whiskers, etc. that have more or less a graphite structure but differ in their agglomeration, particle size, size distribution, degree of graphitization, and therefore in their physical and chemical properties. Of course, all these carbon materials are the result of specific synthesis routes. From a technical point of view, graphite is by far the most important electrode material because it combines good electrical conductivity with a relatively high chemical and electrochemical stability and low price (\rightarrow graphite electrodes). Graphite is also used as electrode material because it can undergo insertion electrochemical reactions (\rightarrow insertion electrochemistry). Even diamond can be used as electrode material provided it is doped to achieve a sufficient \rightarrow conductivity (\rightarrow boron-doped diamond, \rightarrow diamond electrode). See also \rightarrow carbon electrodes, \rightarrow carbon felt electrode, \rightarrow carbon fiber electrode, \rightarrow carbon paste electrode, \rightarrow carbon nanotubes, \rightarrow electrode materials, \rightarrow paraffin impregnated graphite electrode, \rightarrow porous electrode.

Refs.: [i] Pierson HO (1993) *Handbook of carbon, graphite, diamond, and fullerenes*. Noyes Publications, New Jersey; [ii] Yoshimura S, Chang RPH (eds) (1998) *Supercarbon. Synthesis, properties and applications*. Springer, Berlin; [iii] Kinoshita K (1988) *Carbon. Electrochemical and physicochemical properties*. Wiley, New York

FS, FM

Carbon black \rightarrow carbon

Carbon dioxide sensor — An electrochemical device for measuring the \rightarrow partial pressure of carbon dioxide, originally developed for measurements with blood by Severinghaus and Bradley [i]. It consists of a \rightarrow glass electrode as used for \rightarrow pH measurements covered with a membrane selectively permeable for CO₂, e.g., silicone. Between membrane and glass electrode an electrolyte solution containing NaCl and Na₂CO₃ is entrapped.

When CO₂ penetrates from the exterior environment through the membrane into the solution the chemical equilibrium is shifted, the pH values is lowered:

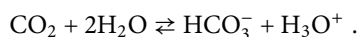

KA

This change is detected by the glass electrode. The potential difference ΔE at the glass electrode is thus controlled by the CO₂ concentration according to

$$\Delta E = \text{const.} + (RT/F) \ln c_{\text{CO}_2} .$$

At room temperature \rightarrow Nernstian slope (59 mV/decade of concentration change) is usually observed. Partial pressure can be derived by applying Henry's law. A catheter configuration suitable for measurements inside blood vessels has been described [ii]. Using other electrolyte constituents and membranes semipermeable for other types of gas sensors for other analytes were developed (including NO₂, SO₂, H₂S, HF [iii]). Various CO₂ sensors with galvanic solid electrolyte cells have been designed [iv].

Refs.: [i] Severinghaus JW, Bradley AF (1958) *J Appl Physiol* 13:515; [ii] Opdycke W, Meyerhoff ME (1986) *Anal Chem* 58:950; [iii] Wang J (1994) *Analytical electrochemistry*. VCH, New York; [iv] Möbius HH (2004) *J Solid State Electrochem* 8:94

RH

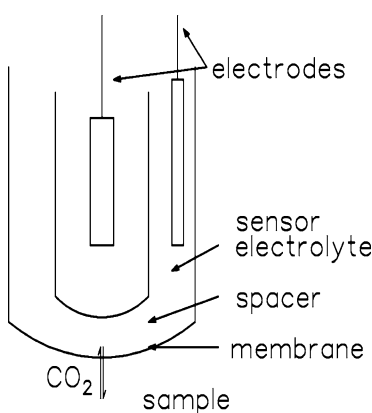

Carbon dioxide sensor — **Figure**. Schematic cross section of a carbon dioxide sensor

Carbon electrodes — Carbon is selected for many electrochemical applications because of its good electrical and thermal conductivity, low density, adequate corrosion resistance, low thermal expansion, low elasticity, and high purity. In addition, carbon materials can be produced in a variety of structures, such as powders, fibers, large blocks, thin solid and porous sheets, nanotubes, fullerenes, graphite, and diamond. Furthermore, carbon materials are readily available and are generally low-cost materials.

There are three common forms of carbon: diamond, graphite, and amorphous carbon. All three are important for electrochemical applications. The ideal graphite structure consists of layers of carbon atoms arranged in hexagonal rings. Metallic properties are exhibited in the direction parallel to the layer planes, while semiconducting properties are exhibited in a perpendicular direction. Because of the anisotropic structure of graphite, it indeed possesses anisotropic properties.

Amorphous carbon may be considered as sections of hexagonal carbon layers of varying size, with very little order parallel to the layers. Between the extremes of graphite and amorphous carbon there is a wide range of carbons with properties that can be tailored, to some extent, for a specific application by controlling the manufacturing conditions and subsequent treatments (heat treatment, chemical oxidation, etc.).

Diamond doped with boron is conductive, and hence can serve as a highly inert and robust electrode material. Indeed, there are many reports on the study of electrochemical reactions with → *boron-doped diamond electrodes*.

Because of the wide variety of carbons that are available, there is a whole range of promising electrochemical applications for these materials, such as → *fuel cells*, → *batteries*, industrial electrochemistry, and → *electro-analytical chemistry*.

In fuel cells, carbon (or graphite) is an acceptable material of construction for electrode substrates, electrocatalyst support, bipolar electrode separators, current collectors, and cooling plates.

Carbon and graphite are used in batteries as electrodes or as additives in order to enhance the electronic conductivity of the electrodes. As electrodes, graphites and disordered carbons reversibly insert lithium, and hence they may serve as the anode material in → *lithium batteries*. Graphitic carbons intercalate lithium in a reversible multi-stage process up to LiC_6 (a theoretical capacity of 372 mAh g^{-1}) and are used as the main anode material in commercial rechargeable Li ion batteries. As additives, carbon and graphite can be found in most of

the composite electrodes of batteries, such as lithium and → *alkaline batteries*. Flow batteries are also batteries where carbon and graphite can be found, both as electrodes and as bipolar separators. For the bipolar separators, nonporous carbon or graphite is required (for example, carbon-polymer composites, dense graphite, or other nonporous carbon such as glassy carbon). Activated carbon and graphite are used as electrodes in these batteries, where the high surface area of these electrodes is used to store the electroactive species. One example is the storage of bromine molecules in the activated carbon electrodes in Zn/Br_2 batteries.

Highly porous carbons can serve as electrodes in → *super* (EDL = electric double layer) *capacitors*. Their very wide electrochemical window allows their use in nonaqueous (relative) high energy-high power density super (EDL) capacitors.

A wide range of applications of carbon materials can be seen in what is termed industrial electrochemistry. These applications include the use of carbon electrodes in reactions involving inorganic compounds (e.g., chlorine evolution, ozone generation, etc.), the synthesis of organic materials using electrochemical methods, electrochemical treatment of solutions (removal and recovery of charged and uncharged species by electroadsorption and ion exchange in the porous structure of the carbon electrodes), and carbon capacitors, where the high and specific surface area leads to an extremely high double layer capacitance.

Last, but not least, is the field of electroanalytical chemistry, in which carbon electrodes can be found. This field includes → *voltammetry*, → *potentiometry*, → *coulometry*, etc., for measuring the concentration and detecting the presence of specific chemical species.

Refs.: [i] Kinoshita K, Berkeley L (1988) *CARBON-Electrochemical and physicochemical properties*. Laboratory, Berkeley; [ii] Nishino A (1996) *J Power Sources* 60:137; [iii] Pleskov YV (2006) *Protection of materials* 42:103; [iv] Nazri GA, Pistoia G (2003) *Lithium batteries: Science and technology*. Kluwer, Boston

NL, DA

Carbon felt electrode — High surface area → *carbon electrodes* (→ *graphite electrodes*) made by carbonization of organic felts or fibers. Precursor materials such as polyacrylonitrile, cellulose, etc. are heated under a reducing or inert atmosphere and complex pyrocarbon structures [i] are formed depending on the temperature. At higher temperatures more graphitic materials are obtained. Applications of carbon felt electrodes are in → *fuel cells* [ii], as high surface area electrodes in water decontamination and → *electrosynthesis* [iii], and in carbon felt composite → *sensors* [iv].

Refs.: [i] Oberlin A (2002) *Carbon* 40:7; [ii] Escribano S, Blachot JF, Etheve M, Morin A, Mosdale R (2006) *J Power Sources* 15:8; [iii] Gonzalez-Garcia J, Montiel V, Aldaz A, Conesa JA, Perez JR, Codina G (1998) *Ind Engin Chem Res* 37:4501; [iv] Tobalina F, Pariente F, Hernandez L, Abruna HD, Lorenzo EL (1998) *Anal Chim Acta* 358:15

FM

Carbon fiber electrode → Edison produced the first carbon fibers by carbonization of cotton threads in 1879. Today polyacrylonitrile (as well as Rayon and various other organic precursors) is the most common precursor for carbon fiber formation [i]. Carbonization of polyacrylonitrile is carried out at 1500 °C to give highly electrically conducting fibers with 5–10 μm diameter. Fibers carbonized at up to 2500 °C are more graphitic with a carbon content of >99%. Carbon fiber-based materials have found many applications due to their exceptionally high tensile strength. In electrochemistry carbon fiber → *microelectrodes* are very important in analytical detection [ii] and for in vivo electrochemical studies [iii]. Carbon fiber textiles are employed in → *carbon felt electrodes*.

Refs.: [i] Pierson HO (1993) *Handbook of carbon, graphite, diamond, and fullerenes*. Noyes Publications, New Jersey; [ii] Zoski CG (2002) *Electroanalysis* 14:1041; [iii] Phillips PEM, Wightman RM (2003) *Trends Anal Chem* 22:509

FM

Carbon nanotubes → *nanotubes* composed of sp²-hybridized carbon atoms arranged in graphite type sheets building-up seamless hollow tubes capped by → *fullerene*-type hemispheres. Their length ranges from tens of nanometers to several microns. They can be divided into two classes; single-walled carbon nanotubes (SWNTs) and multiwalled-carbon nanotubes (MWNTs). SWNTs consist of single hollow tubes with diameter 0.4 to 2 nm. They can be metallic conductors or semiconductors. The conductivity depends on their chirality, presence of catalytic particles, ion doping, and functionalization. MWNTs are composed of concentric tubes. Their diameter ranges from 2 to 100 nm and they can be regarded as metallic conductors. Both classes of carbon nanotubes are already recognized as attractive → *electrode material*.

Refs.: [i] Ijima S (1991) *Nature* 354:56; [ii] Saito R, Dresselhaus R (1998) *Physical properties of carbon nanotubes*. Imperial College Press, London; [iii] Niyogi S, Hamon HA, Hu H, Zhao B, Bhowmik P, Sen R, Itkis ME, Haddon RC (2002) *Acc Chem Res* 35:1105; [iv] www.pa.msu.edu/cmp/csc/nanotube.htm

MO

Carbon paste electrodes — Carbon paste electrodes have been described first by → Adams in 1958 [i]. He has used graphite powder mixed with a mulling liq-

uid. As such bromoform, bromonaphthalene, and → *Nujol* have been used. The paste is housed in a Teflon holder, contacted by a platinum wire, and occasionally a piston is used to renew the surface by extrusion of the used paste. Kuwana and French were the first to modify carbon paste electrodes with electroactive compounds [ii] to measure the response of water insoluble compounds in an aqueous electrolyte solution. Later this approach has been expanded to study the electrochemical behavior of inorganic insoluble compounds that may or may not be electron conductors [iii]. Carbon paste electrodes have been developed in the last decades mainly to incorporate reagents and enzymes to prepare specific electrodes for analytical applications [iv-vi]. The long-term stability of the pastes is a problem, as well as the fact that the binder can affect the electrochemistry of solid embedded particles, if that is the goal of studies.

Refs.: [i] Adams RN (1958) *Anal Chem* 30:1576; [ii] Kuwana T, French WG (1964) *Anal Chem* 36:241; [iii] Scholz F, Meyer B (1998) *Voltammetry of solid microparticles immobilized on electrode surfaces*. In: Bard AJ, Rubinstein I (eds) *Electroanalytical chemistry*, vol. 20. Marcel Dekker, New York; [iv] Švancara I, Vytřas K, Barek J, Zima J (2001) *Crit Rev Anal Chem* 31:311; [v] Gorton L (1995) *Electroanalysis* 7:23; [vi] Kalcher K, Kauffmann JM, Wang J, Švancara I, Vytřas K, Neuhold C, Yang Z (1995) *Electroanalysis* 7:5

FS

Carlisle, Anthony — (Feb. 15, 1768, Stillington/Durham, England – Nov. 2, 1840, London, England) He studied medicine in York, Durham, and London. He became a successful surgeon, was knighted in 1821, and served as the President of the College of Surgeons in 1829. Nevertheless, he is now chiefly remembered for the first electrolysis of water, with → *Nicholson*, in 1800. Nicholson and Carlisle's discovery that electricity can cause water to produce hydrogen and oxygen was a milestone in the history of chemistry [i-iii].

Refs.: [i] Nicholson W, Carlisle A (1800) *Nicholson's Journal (J Natl Phil Chem Arts)* 4:179; [ii] Laidler KJ (1993) *The world of physical chemistry*. Oxford University Press, Oxford, pp 199, 200, 424; [iii] Dunsch L (1985) *Geschichte der Elektrochemie*. VEB Deutscher Verlag für Grundstoffindustrie, Leipzig, pp 31, 131

GI

Carré pile — Assembly of → *Daniell cells* with diaphragms made of paper. See also → *zinc*, → *Zn²⁺/Zn electrodes*, → *Zn²⁺/Zn(Hg) electrodes*, → *zinc-air batteries (cell)*, and → *Leclanché cell*.

Ref.: [i] Hauck WP (1883) *Die Galvanischen Batterien, Accumulatoren und Thermosäulen*, 2nd edn. Hartleben's Verlag, Wien

FS

Casimir force — A force that appears between two flat, uncharged, and parallel metal plates which are close to one another. It is clear that two charged plates attract or repel each other depending on whether they are oppositely or identically charged. This electric force diminishes relatively slowly vs. the distance between the plates. The Casimir force is related to the electrons in the two plates which are more or less mobile, and move rather randomly. Some fluctuations in the electron density appear and this leads to the same effect as in the case of a positive or negative charge at the plates. Casimir force is weak, depends on temperature, and can be eventually considered as similar to the → *van der Waals forces* between two uncharged atoms. It decreases much stronger with the distance between the plates compared to the electric forces between two charged plates.

The attractive Casimir force between two plates of area A can be calculated approximately using the formula $F = (phcA)/(480r^4)$, where h is → *Planck constant*, c is the speed of light, and r is the distance between the plates.

Casimir force was predicted by H.B.G. Casimir in 1948. The first experimental confirmation came in 1958, and it was rigorously described in 1997 [ii].

Refs.: [i] Bressi G, Carugno G, Onofrio R, Ruoso G (2002) *Phys Rev Lett* 88:1804; [ii] Lamoreaux SK (1997) *Phys Rev Lett* 78:5

ZS

Castner, Hamilton Young — (Sep. 11, 1858, Brooklyn, New York, USA – Oct. 11, 1899, Saranac Lake, New York, USA) Castner studied at the Brooklyn Polytechnic Institute and at the School of Mines of Columbia University. He started as an analytical chemist, however, later he devoted himself to the design and the improvement of industrial chemical processes. He worked on the production of charcoal, and it led him to investigate the Deville's aluminum process. He discovered an efficient way to produce sodium in 1886 which made also the production of aluminum much cheaper. He could make aluminum on a substantial industrial scale at the Oldbury plant of The Aluminium Company Limited founded in England. However, → *Hall* and → *Héroult* invented their electrochemical process which could manufacture aluminum at an even lower price, and the chemical process became obsolete. Castner also started to use electricity, which became available and cheap after the invention of the dynamo by → *Siemens* in 1866, and elaborated the → *chlor-alkali electrolysis* process by using a mercury cathode. Since Karl Kellner (1851–1905) also patented an almost identical procedure, the process became known as Castner–Kellner process. Cast-

ner bought Kellner's patent, and the production of pure NaOH and Cl₂ started at Oldbury in 1894. The mass production of these two chemicals revolutionized the textile and in general the chemical industry.

Refs.: [i] Williams TI (1993) *Endeavour* 17:89; [ii] Dunsch L (1985) *Geschichte der Elektrochemie*. VEB Deutscher Verlag für Grundstoffindustrie, Leipzig, pp 88, 134

GI

Castner cell — (also Castner–Kellner cell) Electrochemical cell employed in sodium winning by electrolysis of molten NaOH. According to

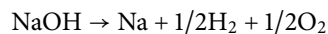

with the cathode reaction

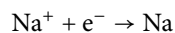

the anode reaction

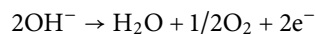

and the chemical reaction in the melt

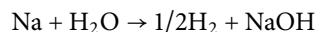

the faradaic yield with respect to the produced sodium is only 50%. The moderate cell voltage of 4.3 to 5 V kept the process competitive until the → *Downs cell (process)* was sufficiently advanced. In the Castner cell an iron cylinder serves as anode, it is surrounded by an iron cylinder used as cathode. Molten sodium with lower density than molten NaOH rises and is separated from the melt; oxygen rises separately and does not meet molten sodium. Hydrogen cogenerated with sodium leaves the cell together with the rising sodium. Operating temperature is low, between 310 and 330 °C. At lower temperatures the melt solidifies, at higher temperatures sodium is dissolved in the melt. Because the NaOH has to be manufactured electrolytically itself the energy needed for electrolysis and dehydration of the solution of NaOH adds to the unfavorable energy balance, thus the → *Downs process* dominates because NaCl needed for this process does not need further purification resulting in a better energy balance.

RH

Catalymetry — A kinetic method for chemical analysis in which the → *analyte* is the → *catalyst* whose concentration is determined from its effect upon the → *reaction rate* data of the → *indicator*. Thus, conditions are provided in such a way that the concentration of the

→ *analyte* can be determined from an → *indicator* reaction involving reactants or products that can be easily measured. This method of quantification is among the most sensitive ones [i]. The use of → *catalytic currents* in → *voltammetry* (→ *polarography*) can be considered as a kind of catalymetry [ii, iii].

Refs.: [i] Skoog D, West D, Holler F (1996) *Fundamentals of analytical chemistry*. Saunders College Publishing, New York; [ii] Henrion G, Scholz F, Schmidt R, Fabian I (1981) *Z Chem* 21:104; [iii] Tur'yan YI, Ruvinskiy OE, Zaitsev PM (1998) *Polarograficheskaya katalimetriya*. Khimiya, Moscow

Catalysis — is a phenomenon of augmentation of the rate of a chemical reaction caused by addition of a foreign substance, called a catalyst, which remains unconsumed at the end of the reaction. The catalyst does not enter into the overall reaction and does not modify the overall → *Gibbs energy* change in the reaction. The catalyst is both a reactant and a product of the reaction. Catalysis can be divided into homogeneous and heterogeneous catalysis. In homogeneous catalysis, only one phase exists. In heterogeneous catalysis, the reaction takes place at the interface between phases. See also → *electrocatalysis*, → *Brdička*, → *catalymetry*, → *catalytic current*, → *catalytic hydrogen evolution*, and → *Mairanovskii*.

Refs.: [i] Svehla G (1993) *Pure Appl Chem* 65:2291; [ii] Cornils B, Herrmann WA, Schlögl R, Wong C (eds) (2003) *Catalysis from A to Z: A concise encyclopedia*, 2nd edn. Wiley-VCH, Weinheim

Catalytic current — is a → *faradaic current* that is obtained as a result of a catalytic electrode mechanism (see → *electrocatalysis*) in which the catalyst (Cat) is either dissolved in the bulk solution or adsorbed or immobilized at the electrode surface, or it is electrochemically generated at the electrode–electrolyte solution interface [i]. The current obtained in the presence of the catalyst and the substrate (S) must exceed the sum of the currents obtained with Cat and S separately, provided the currents are measured under identical experimental conditions. The catalytic current is obtained in either of the two following general situations:

(1) The Cat is either oxidized (see → *oxidation*) or reduced (see → *reduction*) at the electrode surface to give a product Cat', which then undergoes chemical → *redox reaction* with S. One of the products of the chemical redox reaction between Cat' and S is either Cat or an → *intermediate* of the overall → *electrode reaction* in which Cat' is produced at the electrode

surface. In this regenerative electrode mechanism the Cat/Cat' → *redox couple* serves as a → *redox mediator* to shuttle electrons between the S and the → *electrode* (Scheme 1). As a consequence, S undergoes electrochemical transformation at the → *formal potential* of the redox mediator Cat/Cat'. In the absence of the catalyst, the substrate requires a higher → *overpotential* to exchange electrons directly with the electrode compared to the formal potential of the redox mediator Cat/Cat', i.e., the system has to possess an appreciable degree of electrochemical irreversibility. Typical examples are electrode mechanisms involving inorganic oxidants as substrates (hydrogen peroxide, hydroxyl amine, chlorate, chlorite, perchlorate, bromate, iodate, nitrate, nitrite, persulfate) and transition metal ions showing two stable oxidation states as catalysts (Cu, Ti(IV), V(V), Cr(III), Mo(VI), W(VI), Fe(III), Co(III), Ru(III), Os(VIII), Y(III), and U(VI)) [ii]. Furthermore, numerous examples for a regenerative catalytic electrode mechanism are related to → *chemically modified electrodes*, where the catalyst (e.g., ferrocene, cyano complexes of iron and ruthenium, organic molecules with a large π -bond system such as phenoxazine, tetrathiafulvalinium tetracyanoquinodimethane) is immobilized at the electrode surface and undergoes a very fast electron transfer reaction [iii] with the electrode and the substrate present in the electrolyte solution. The utilization of catalytic currents for analytical purposes allows reaching extremely low detection limits [iv].

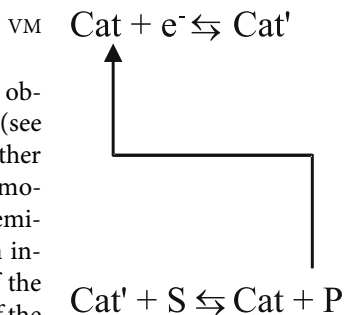

Catalytic current — **Figure.** Reaction scheme of a reductive regenerative catalytic electrode mechanism (the charge of the species is omitted)

(2) The Cat, or its product of electrode oxidation or reduction Cat', is immobilized at the electrode surface and decreases the overpotential for oxidation or reduction of the S, without being involved in the chemical redox reaction with the S. Typical example is the catalytic effect of underpotential deposited layer of lead on a platinum electrode, on anodic oxidation of methanol [v].

Further examples are electrode mechanisms involving ligand-catalyzed metal ion reduction (e.g., reduction of Ni^{2+} at the mercury electrode catalyzed by adsorbed cysteine [vi]) hydrogen evolution reaction at the mercury electrode catalyzed by adsorbed organic bases, platinum metal particles, and transition metal complexes [vii].

Refs.: [i] Bănică FG, Ion A (2000) *Electrocatalysis-based kinetic determination*. In: Meyers RA (ed) *Encyclopedia of analytical chemistry*. Wiley, Chichester, p 11115; [ii] Zaitsev PM, Zhdanov SI, Nikolaeva TD (1982) *Russ Chem Rev* 51:968; [iii] Wring SA, Hart JP (1992) *Analyst* 117:1215; [iv] Pelzer J, Scholz F, Henrion G, Heininger P (1989) *Fresenius Z Anal Chem* 334:331; [v] Beden B, Kadirgan F, Lamy C, Leger JM (1982) *J Electroanal Chem* 142:171; [vi] Bănică FG (1985) *Talanta* 32:1145; [vii] Bănică FG, Ion A (2000) *Electrocatalysis-based kinetic determination*. In: Meyers RA (ed) *Encyclopedia of analytical chemistry*. Wiley, Chichester, p 11128

VM

Catalytic hydrogen evolution — Hydrogen is formed by reduction of protons in acidic or by reduction of water in alkaline solutions at electrode potentials sufficiently more negative than $E_{\text{SHE}} = 0 \text{ V}$ in the former and at $E_{\text{SHE}} = -0.828 \text{ V}$ in the latter electrolyte solution. The actual rate of hydrogen evolution depends on the properties of the employed electrode material [i]. An electrode material showing a high rate at a selected electrode potential is considered a good (active) electrocatalyst (\rightarrow *electrocatalysis*), a low rate indicates a low catalytic activity. Platinum and some other metals of the platinum group are good electrocatalysts whereas mercury is a poor catalyst. The activity is expressed by giving the \rightarrow *standard exchange current density* j_0 or the standard rate constant k_s .

In \rightarrow *polarography* sometimes \rightarrow *faradaic currents* are observed which cannot be attributed to diffusion-limited reduction of electroactive species under investigation. Sometimes substances (which are not necessarily electroactive themselves) lower the hydrogen overpotential of the mercury electrode in various ways (by adsorption, by acting as a redox mediator), thus a hydrogen evolution current (a catalytic hydrogen wave) is observed [ii–iv]. See also \rightarrow *Mairanovskii*.

Refs.: [i] Norskov JK, Bligaard T, Logadottir A, Kitchin JR, Chen JG, Pandelov S, Stimming U (2005) *J Electrochem Soc* 152:J23; [ii] Mairanovskii SG (1964) *Russ Chem Rev* 33:38; [iii] Leibzon VN, Churilina AP, Mendkovich AS, Gul'tyai VP (1986) *Russ Chem Bull* 35:1743; [iv] Mairanovskii SG (1968) *Catalytic and kinetic waves in polarography*. Plenum Press, New York

RH

Catalytic hydrogen wave \rightarrow *catalytic hydrogen evolution*

Catalytic reactions in electrochemistry \rightarrow *chemical reactions in electrochemistry*

Cataphoresis — [Greek] Movement of positively charged colloidal particles in a suspension towards the cathode (see also: \rightarrow *anaphoresis*, \rightarrow *electrokinetic phenomena*).

RH

Cation — A positively charged ion. A cation has fewer electrons than protons and is attracted by a negatively charged \rightarrow *electrode*. The name *ion* was created by \rightarrow *Faraday*, from Greek ίόν , neutral present participle of ίεναι , “to go”, so *cation*, κατιόν , means “(a thing) going down”.

BM

Cation vacancies \rightarrow *vacancies*

Cathode \rightarrow *electrode* where \rightarrow *reduction* occurs and electrons flow from electrode to electrolyte. At the other electrode, which is called an \rightarrow *anode*, electrons flow from electrolyte to electrode. It follows that in a \rightarrow *battery*, the cathode is the positive electrode. In \rightarrow *electrolysis*, to the contrary, the cathode is the negative electrode. See also \rightarrow *anode*, \rightarrow *Faraday*, \rightarrow *Whewell*.

TO

Cathodic corrosion protection \rightarrow *corrosion protection*

Cathodic partial current (density) — For a single \rightarrow *electrode reaction*, the total current is composed of anodic and cathodic \rightarrow *partial currents*.

When the rate is controlled by the \rightarrow *charge transfer* step according to the \rightarrow *Butler–Volmer equation* the cathodic partial current density (j_c) can be expressed as follows:

$$j_c = -j_0 \exp\left(-\frac{\alpha_c n F \eta}{R T}\right) \quad (1)$$

assuming that $c_{\text{O}}(x = 0) \approx c_{\text{O}}^*$ (O stands for oxidized form) which is the case in intensively stirred solutions; j_0 is the \rightarrow *exchange current density*, α_c is the cathodic \rightarrow *transfer coefficient*, n is the \rightarrow *charge number* of the electrode reaction, F is the \rightarrow *Faraday constant*, R is the \rightarrow *gas constant*, T is the absolute temperature, η is the \rightarrow *overpotential*, $c_{\text{O}}(x = 0)$ and c_{O}^* are the concentrations of the reacting species (oxidized form of the redox couple) at the electrode surface and the bulk solution, respectively.

By using the \rightarrow formal potential ($E_c^{\ominus'}$) and the \rightarrow standard rate constant (k_s)

$$j_c = -nFk_s c_O(x=0) \exp\left(-\frac{\alpha_c nF(E - E_c^{\ominus'})}{RT}\right), \quad (2)$$

where E is the \rightarrow electrode potential. When $c_O(x=0)$ is substantially higher or lower than c_O^*

$$j_c = -j_o \frac{c_O(x=0)}{c_O^*} \exp\left(-\frac{\alpha_c nF\eta}{RT}\right). \quad (3)$$

In the potential region of \rightarrow diffusion \rightarrow limiting current ($j_{L,c}$)

$$j_{L,c} = -nFk_{mo}c_O^*, \quad (4)$$

where k_{mo} is the \rightarrow mass transport coefficient.

In the potential region where mixed kinetic-diffusion control prevails

$$j_c = -j_o \left(1 - j_c/j_{L,c}\right) \exp\left(-\frac{\alpha_c nF\eta}{RT}\right). \quad (5)$$

The cathodic partial current may be a sum of several partial currents when two or more electrode processes take place simultaneously (see \rightarrow partial current), e.g., in \rightarrow hydrogen evolution that accompanies metal deposition at high negative potentials.

In this case

$$j_c = j_{1,c} + j_{2,c} \quad (6)$$

$$j_c = -j_{o,1} \frac{c_{O,1}(x=0)}{c_{O,1}^*} \exp\left(-\frac{\alpha_{c,1} n_1 F \eta}{RT}\right) - j_{o,2} \frac{c_{O,2}(x=0)}{c_{O,2}^*} \exp\left(-\frac{\alpha_{c,2} n_2 F \eta}{RT}\right). \quad (7)$$

Refs.: [i] Erdey-Grúz T, Volmer M (1930) *Z phys Chem* A150:203; [ii] Parsons R (1974) *Pure Appl Chem* 37:503; [iii] Inzelt G (2002) *Kinetics of electrochemical reactions*. In: Scholz F (ed) *Electroanalytical methods*. Springer, Berlin, pp 29–33; [iv] Bard AJ, Faulkner LR (2001) *Electrochemical methods*. Wiley, New York, pp 98–103

Cathodic stripping voltammetry — Refers to a family of procedures involving a \rightarrow preconcentration by electrochemical oxidation (or reduction) of the analyte (or a salt or derivative of the analyte) onto (or into) the working electrode prior to its direct or indirect determination by means of an electroanalytical technique (see also \rightarrow stripping voltammetry, and \rightarrow anodic stripping voltammetry) [i]. During the stripping step, i.e.,

a voltammetric scan, the deposit is dissolved by **reduction**. A typical example is the oxidative deposition of Hg_2Cl_2 at a \rightarrow mercury electrode from a solution containing chloride ions followed by the **reductive dissolution** of the deposit. Another example is the reductive deposition of Cu_2Se from a Se(IV) solution spiked with Cu^{2+} , and its **reductive dissolution** with formation of copper and H_2Se .

Ref.: [i] Fogg AG, Wang J (1999) *Pure Appl Chem* 71:891

AMB

Catholyte \rightarrow electrolyte solution in the cathodic compartment of an electrolysis cell (see \rightarrow electrochemical cells, \rightarrow electrolyzer) or \rightarrow galvanic cell, i.e., in that part of the cell where the \rightarrow cathode is placed.

FS

$C_{rev}E_{rev}$ diagnostics in cyclic voltammetry — Considering the $C_{rev}E_{rev}$ mechanism given with the following reaction scheme for the case of a reduction \rightarrow see CE process,

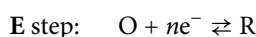
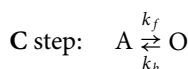

the following simple diagnostic criteria apply [i–iii]:

- if the chemical step (C) is fast relative to the scan rate, then the cyclic voltammogram shows the features of a simple reversible electron transfer, with a potential shift due to the pre-equilibrium (Fig. 1a) $\rightarrow E_{rev}$.
- if the chemical step (C) is slow relative to the scan rate, then:

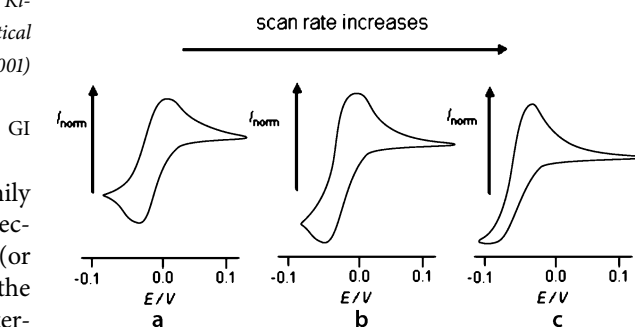

$C_{rev}E_{rev}$ diagnostics in cyclic voltammetry — Figure. The effect of the scan rate on the current components of the simulated cyclic voltammograms of a $C_{rev}E_{rev}$ reaction

- the cathodic current (at more negative potentials) starts to diminish with increasing scan rate (Figs. 1b and c)
- the ratio $I_{p,Red}/v^{0.5}$ decreases as the scan rate increases
- the ratio $I_{p,Red}/I_{p,Ox} < 1$ (for a reduction processes) and it decreases by increasing the scan rate
- in the region of kinetic control, the half-wave peak potential $\Delta E_{p/2}$ (for reduction processes) shifts in negative direction for 30 mV/n per decade increase of the scan rate.

Refs.: [i] Nicholson RS, Shain I (1964) *Anal Chem* 36:706; [ii] Marken F, Neudeck A, Bond AM (2001) *Cyclic voltammetry*. In: Scholz F (ed) *Electroanalytical methods*. Springer, Berlin, pp 50–97; [iii] Bard AJ, Faulkner L (2001) *Electrochemical methods*. Wiley, New York, pp 471–533

RG

CE process — These are coupled reactions, where the electroactive compound O is produced by a chemical reaction C, which precedes the electron transfer step E:

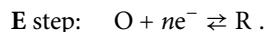

A classical example for a CE process is the reduction of formaldehyde to methanol, where the formaldehyde is formed by dehydration of methan-di-ol [i, ii] → *chemical reactions in electrochemistry, preceding reaction*.

Refs.: [i] Bilewicz R, Wikiel K, Osteryoung R, Osteryoung J (1989) *Anal Chem* 61:965; [ii] Bard AJ, Faulkner L (2001) *Electrochemical methods*. Wiley, New York, pp 471–533

RG

CEER process — (Capenhurst electrolytic etchant regeneration process) Electrochemical process for continuous copper removal from printed circuit board etching solutions employing either cupric chloride or ammoniacal etchant. In a cell divided by a cation exchange membrane the etching process is essentially reversed. In case of the cupric chloride etchant the etchant solution is pumped to the anode, the processes are at the

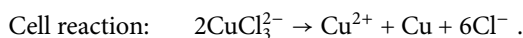
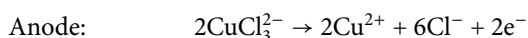

Copper ions generated at the anode pass through the membrane and are deposited at the cathode in dendritic form, they are recovered from the bottom of the cell. The respective etching process is



In the etching process employing a slightly acidic ammoniacal etchant the etching reaction is

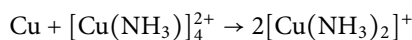

and

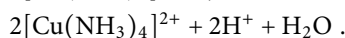
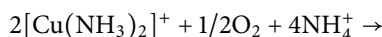

The etchant solution is pumped to the cathode of the regeneration cell, electrode reactions are at the

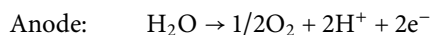

Cell reaction (including homogeneous steps):

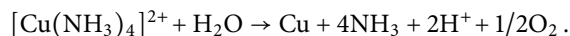

In the CEER cell the etchant is pumped to the cathode where copper removal proceeds.

Ref.: [i] Pletcher D, Walsh FC (1993) *Industrial electrochemistry*. Blackie Academic & Professional, London

RH

Cell constant — The specific conductivity of matter is defined as the conductivity measured between two conducting plates (electrodes in measurements of ionic conduction) of 1 cm² area spaced at a distance of 1 cm (→ *conductivity cell*). In practical construction these geometrical specifications are not easily obtained, and the actual dimension may differ. To convert conductivity data obtained with a real cell having different geometric dimension the conductivity χ_{act} of a solution with well-known specific conductivity χ_{ref} is measured with this cell. Taking the reference value χ_{ref} the cell constant κ is obtained by $\kappa = \chi_{ref}/\chi_{act}$. Subsequently measured conductivity χ_{act} employing this cell can easily be converted into specific conductivities χ according to $\chi = \kappa\chi_{act}$.

Ref.: [i] Bockris JO'M, Reddy AKN (2006) *Modern electrochemistry*. Springer, New York

RH

Cell diagram — A → *galvanic cell* is represented by a diagram. Thus, the chemical cell, consisting of an aqueous

solution of hydrogen chloride (activity: a , concentration: c), a platinum–hydrogen electrode (partial pressure of hydrogen: p), and a silver–silver chloride electrode, both with copper terminals is represented by the diagram

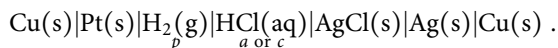

Although this diagram has been recommended by the IUPAC Commission of Electrochemistry [i] it is not entirely correct. It would be better to write as follows

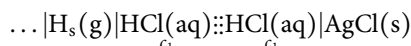

since \rightarrow liquid junction potential may arise even in this case because at the \rightarrow hydrogen electrode HCl solution is saturated by H_2 , while at the silver–silver chloride electrode HCl solution is saturated by AgCl.

The cell diagram of the \rightarrow Daniell cell is

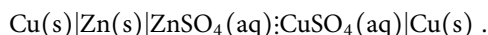

The diagram of the cell for pH measurements when a glass electrode is used [ii]:

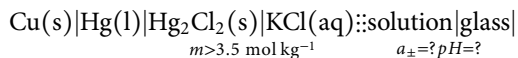

A single vertical bar (|) should be used to represent a phase boundary, a dashed vertical bar (:) to represent a junction between miscible liquids, and double, dashed vertical bars (::) to represent a liquid junction, in which the liquid junction potential has been assumed to be eliminated (see also \rightarrow concentration cells).

Refs.: [i] Parsons R (1974) *Pure Appl Chem* 37:503; [ii] IUPAC quantities, units and symbols in physical chemistry (1993) Mills I, Cvitas T, Homann K, Kallay N, Kuchitsu K (eds), Blackwell Sci Publ, Oxford, p 62

GI

Cell reaction — A chemical reaction occurring spontaneously in a \rightarrow galvanic cell is called the cell reaction. The \rightarrow Gibbs energy change of the reaction (ΔG) is converted into electrical energy (via the current) and heat. The cell reaction in a galvanic cell is spontaneous, i.e., ΔG is negative. The reaction equation should be written in such a way that $\Delta G < 0$ when it proceeds from left to right. The peculiarity of the cell reaction is that the chemical processes (oxidation and reduction)

take place spatially separated at the \rightarrow electrodes in such a way that they are interconnected by the ion transport through the solution separating the two electrodes. They are called half-reactions or \rightarrow electrode reactions. Oxidation takes place at the \rightarrow anode, and reduction at the \rightarrow cathode.

The reaction to which ΔG and the potential of the cell reaction (E_{cell}) refers should be clearly indicated, for example

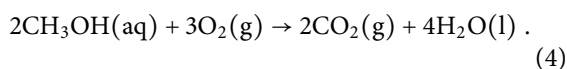
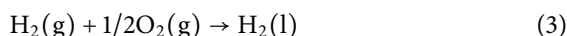
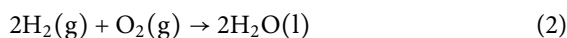
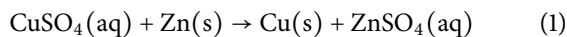

The respective half-reactions are as follows

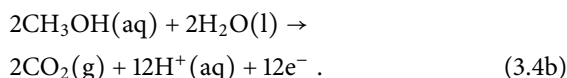
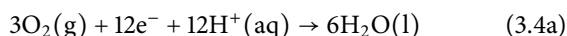
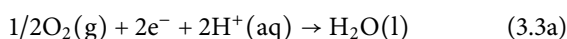
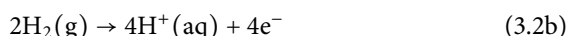
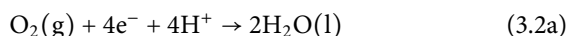
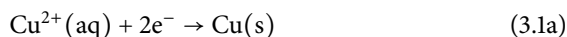

The expression “cell reaction” is used almost exclusively for the spontaneous reactions occurring in galvanic cells [i–iv]. However, also in electrolysis cells (\rightarrow electrochemical cells) chemical transformations take place, when current is passed through the cell from an external source. Evidently, we may also speak of cell reactions even in this case, albeit additional energy is needed for the reaction to proceed since $\Delta G > 0$.

Refs.: [i] Parsons R (1974) *Pure Appl Chem* 37:503; [ii] Atkins PW (1995) *Physical chemistry*. Oxford University Press, Oxford, pp 330–332; [iii] Rieger PH (1993) *Electrochemistry*. Chapman & Hall, New York, pp 5–9; [iv] Bard AJ, Faulkner LR (2001) *Electrochemical methods*. Wiley, New York, pp 2–5, 48–52

GI

Cell voltage \rightarrow electric potential difference of a galvanic cell

GI

Cementation → *displacement deposition*

Ceria → *cerium dioxide*

Cerium dioxide — Cerium dioxide (ceria), $\text{CeO}_{2-\delta}$, with a cubic fluorite-type structure is the only thermodynamically stable phase in the binary Ce–O system at oxygen partial pressures close to atmospheric. The materials derived from CeO_2 by → *doping*, find numerous applications in electrochemistry, particularly as oxygen ion-conducting → *solid electrolytes*, → *mixed ionic–electronic conductors*, and components of → *solid oxide fuel cell* (SOFC) → *electrodes* and catalysts [i,ii]. At temperatures below 1700 K in air, oxygen nonstoichiometry (δ) in ceria is relatively small; the concentration of → *point defects* determining the transport properties depends strongly on the pre-history and on the dopant/impurity content. The oxygen → *ion conductivity* can be substantially increased by increasing the concentration of oxygen → *vacancies* via doping with lower-valence cations, in particular rare-earth and alkaline-earth metal ions. A highest level of oxygen ionic transport is characteristic of the → *solid solutions* $\text{Ce}_{1-x}\text{M}_x\text{O}_{2-\delta}$, where M = Gd or Sm, $x = 0.10\text{--}0.20$. The main advantages of these electrolytes include a higher ionic conductivity with respect to → *stabilized zirconia*, a better stability compared to → *bismuth oxide* based materials and → *BIMEVOX*, and a lower cost in comparison with lanthanum gallate-based → *perovskites*. The main problems in using doped ceria as SOFC electrolyte arise from the partial reduction of Ce^{4+} to Ce^{3+} under the reducing conditions, resulting in a significant electronic conductivity and lattice expansion. An important feature of ceria-based materials relates to their high catalytic activity, particularly in many oxidation reactions.

Refs.: [i] Inaba H, Tagawa H (1996) *Solid State Ionics* 83:1; [ii] Khariton VV, Yaremchenko AA, Naumovich EN, Marques FMB (2000) *J Solid State Electrochem* 4:243

VK

Cesium cation conductors → *solid electrolyte*

Cesium-conducting solid electrolyte → *solid electrolyte*

Channel electrode → *electrochemical cell (practical aspects)* (subentry → *channel flow electrochemical cell*), and → *hydrodynamic electrodes*

Channel flow cell → *electrochemical cell (practical aspects)* (subentry → *channel flow electrochemical cell*), and → *hydrodynamic electrodes*

Chaotropes → *Hofmeister series*

Chapman, David Leonard



(By kind permission of the Principal and Fellows of Jesus College, Oxford)

(Dec. 6, 1869, Wells, Norfolk, England – Jan. 17, 1958, Oxford, England) Chapman studied in Oxford, and then he was a lecturer at Owens College (which later became part of the University of Manchester). In 1907 he returned to Oxford, and led the chemistry laboratories of the Jesus College until his retirement in 1944 [i]. Chapman's research has mostly been focused on photochemistry and chemical kinetics; however, he also contributed to the theory of electrical → *double layer* [ii]. His treatment of the double layer was very similar to that elaborated by → *Gouy* earlier, and what has come to be called the Gouy–Chapman double-layer model [i,iii].

Refs.: [i] Laidler KJ (1993) *The world of physical chemistry*, Oxford Univ Press, Oxford; [ii] Chapman DL (1913) *A contribution of the theory of capillarity*. *Phil Mag* 25(6):475; [iii] de Levie R (2000) *J Chem Education* 77:5

GI

Characteristic potential → *potential*, subentry → *characteristic potential*

Charcoal → *carbon*

Charge

- (a) In electrochemistry, the term charge is used for the electric charge (physical quantity) with positive or negative integer multiples of the → *elementary electric charge*, e . The sum of charges is always conserved within the time and space domains in which charge is transported [i]. Electrochemical charge is categorized into faradaic charge (→ *faradaic reaction*, → *Faraday's law*) and capacitive charge (→ *capacitor*). The faradaic charge is provided by → *charge transfer* reactions at an electrochemical → *interface*, and is equal to the product of the number of reacting species, N , the stoichiometric number of electrons, n , and the elementary

charge, i.e., $Q = neN$. It is practically detected via the current, $I = dQ/dt = ne(dN/dt)$, and hence is evaluated from the time-integration of the current to provide the amount of reacting species. On the other hand, the capacitive charge is the charge accumulated in a capacitance at an electrochemical interface. It is expressed as the product of the capacity, C , and the potential difference, ΔE , through $Q = C\Delta E$ [ii]. It does not include time-variation of electroactive species, and hence is called non-faradaic charge. See also \rightarrow *charge, capacitive*.

- (b) The term charge is also frequently used in the connections “positive charge” and “negative charge” just to indicate the sign of it.

Refs.: [i] Griffiths DJ (1989) *Introduction to electrodynamics*, 2nd edn. Prentice Hall, p 4; [ii] Bard AJ, Faulkner LR (2001) *Electrochemical methods*, 2nd edn. Wiley, New York, p 11

KA

Charge capacity of a battery — This is a term related to power sources and defines the amount of electrical charge that is stored in a \rightarrow *battery* material and/or in an entire battery electrode. Charge \rightarrow *capacity* is measured in \rightarrow *coulombs*. Practically, charge is usually expressed in Ah (ampere hour). 1 Ah is 3600 coulombs.

Hence, the charge capacity of one mol of electroactive material that undergoes one electron transfer per process is 1 F or 26.8 Ah. For the practical world of energy storage and conversion, highly important is the specific charge capacity (or simply specific capacity), which is expressed in Ah per 1 gram (Ah g^{-1}) for gravimetric specific capacity or in Ah per 1 liter (Ah L^{-1}) for volumetric specific capacity. It is important to distinguish between theoretical and practical specific capacity. Theoretical specific charge capacity is based on the molecular weight of the active material and the number of electrons transfers in the electrochemical process. Practical specific charge capacity is the actual capacity that can be obtained in the process and it depends on many practical factors such as the kinetic limitations of the electrochemical process, temperature of operation, cutoff voltage, electrodes design and configuration, etc.

In the fields of capacitors and rechargeable batteries charge capacity defines the capacity that is involved in the charge process of the device and is usually compared to the capacity that is involved in the discharge process (discharge capacity). The losses in the charge process should be minimal in order to obtain good cycleability life of the device.

Refs.: [i] Linden D (1994) *Handbook of batteries*, 2nd edn. McGraw-Hill, New York; [ii] Crompton TR (2000) *Battery reference book*, 3rd edn. Newness, Oxford; [iii] Dell RM, Rand DAJ (2001) *Understanding batteries*. Royal Society of Chemistry

DA

Charge, capacitive — Capacitive charge is the charge accumulated in an interfacial capacitance by $Q = C\Delta E$, where C is the \rightarrow *capacitance* and ΔE is the voltage, i.e., the potential difference. It can be obtained from the time-integration of the current. The capacitance is evaluated from time-dependent applied voltage with a small amplitude by use of $I = dQ/dt = E(dC/dt) + C(dE/dt)$ for negligibly small values of dC/dt . For \rightarrow *linear sweep voltammetry* with the scan rate, v , the capacitive current is approximated as Cv , and the charge is expressed by $Q = (1/v) \int_{E_1}^{E_2} IdE$, where E_1 and E_2 are the initial and the final potentials for the potential scan. If electroactive species are adsorbed to alter the \rightarrow *adsorption* layer, the term dC/dt contributes significantly to the capacitive charge. Similar complications occur when adsorbed species cause redox reactions. See also \rightarrow *charge*.

KA

Charge carrier — Generic denomination of particles or quasiparticles, like \rightarrow *electrons*, \rightarrow *holes*, \rightarrow *ions*, \rightarrow *polarons*, \rightarrow *bipolarons*, responsible for electric \rightarrow *charge transport*.

IH

Charge density — Electrical charge per unit of area or volume. In electrochemistry charge density most frequently refers to electrodes, in which the charge density equals the excess electrical charge divided by the electrode area, usually expressed in units of $\mu\text{C cm}^{-2}$. The charge density of electrodes is one of the most important factors determining the \rightarrow *double-layer* structure. In the simplest case of a double-layer \rightarrow *capacitor*, the stored charge density is related to the voltage between the plates through the equation: $\sigma = \epsilon\epsilon_0 V/d$ for which d is the distance between the plates and ϵ and ϵ_0 represent the \rightarrow *dielectric constant* of the vacuum and the medium, respectively. Surface charge density can be calculated from \rightarrow *electrocapillary* measurements for ideally polarized electrodes, using the \rightarrow *Lippman equation* $-\sigma^M = -(\partial\gamma/\partial E)_{T,P,\mu_j,\dots}$, for which σ^M is the excess charge on the \rightarrow *ideally polarized electrode*, γ is the \rightarrow *interfacial tension* of the electrode, E is the potential difference between the \rightarrow *working electrode* and the \rightarrow *ref-*

erence electrode, j are electrically neutral components of one or other of the phases (electrode and solution). The derivative of the electrode charge density with respect to potential gives the important characteristic \rightarrow differential capacity, $C_d = (\partial\sigma^M/\partial E)$ of a given system (see \rightarrow double layer).

The volumetric charge density is of interest in the study of ionic solutions, in which one can calculate the charge density around a specific ion. This is done by using the \rightarrow Poisson equation, based on electrostatic electric fields or by \rightarrow Boltzman distribution law of classical statistic mechanics. For the simpler case of dilute solutions this approach yields the expression: $\rho = -\frac{\epsilon}{4\pi} \left[\frac{1}{r^2} \frac{d}{dr} \left(r^2 \frac{d\Psi_r}{dr} \right) \right]$ and the other $\rho = -\sum_i \frac{n_i^0 z_i^2 e_0^2 \Psi_r}{kT}$ where ρ and Ψ_r are the charge density and the average electrostatic potential in a volume element dV , at a distance r from a central ion, ϵ represents the dielectric constant, z_i and e are the ions and electronic charge and \sum_i refers to the summation over all the ionic species i . See also \rightarrow Debye-Hückel length, and \rightarrow Debye-Hückel-Onsager theory.

Refs.: [i] Bard AJ, Faulkner RL (1980) *Electrochemical methods*. Wiley, New York, pp 488-515; [ii] Bockris JO'M, Reddy AKN, Gamboa-Aldeco M (1998) *Modern electrochemistry: Ionics*, 2nd edn. Plenum Press, New York, pp 232-237; [iii] Rieger PH (1994) *Electrochemistry*. Chapman & Hall, New York, p 61; [iv] Trasatti S, Parsons R (1986) *Pure Appl Chem* 58:437

YG

Charge efficiency \rightarrow coulometric efficiency

Charge injection — Increment of concentration of \rightarrow charge carriers inside a material through transport across the \rightarrow interfaces with outer media. In \rightarrow semiconductors, for example, free charge carriers may be generated internally by thermal excitation or by photoexcitation, maintaining charge neutrality, and injection from electrodes is used to allow charge flow (current) and to achieve excess concentration of free charge carriers.

Ref.: [i] Kao KC, Hwang W (1981) *Electrical transport in solids*. Pergamon, Oxford

IH

Charge number of the cell reaction — Symbol: n (symbol z is also used, however, it is better to reserve symbol z for the \rightarrow charge number of an ion in order to avoid confusion.) n is a positive number.

The charge number of the cell reaction is the stoichiometric number equal to the number of electrons transferred in the \rightarrow cell reaction as formulated.

For instance,

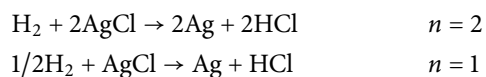

We may define also the charge number of the \rightarrow electrode reaction.

For instance,

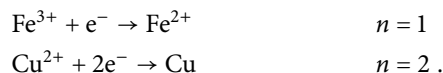

Note that there is no connection between the charge number of the cell (electrode) reaction and the charge number of ions (see \rightarrow charge number of an ion).

Refs.: [i] Parsons R (1974) *Pure Appl Chem* 37:503; [ii] Inzelt G (2006) *Standard potentials*. In: Bard AJ, Stratmann M, Scholz F, Pickett CJ (eds) *Encyclopedia of electrochemistry*. vol. 7a, Wiley-VCH, Weinheim

GI

Charge number of an ion — Symbol: z_B .

It is a number which is positive for cations and negative for anions: z_B is the ratio of charge carried by ion B to the charge carried by the proton (electron).

For instance,

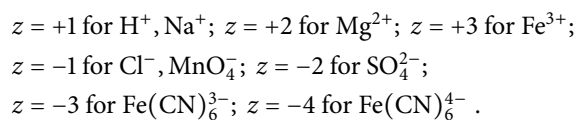

Refs.: [i] Parsons R (1974) *Pure Appl Chem* 37:503; [ii] IUPAC quantities, units and symbols in physical chemistry (1993) Mills I, Cvitas T, Homann K, Kallay N, Kuchitsu K (eds) *Blackwell Scientific Publications*, Oxford London Edinburgh, p 58

GI

Charge transfer coefficient — (also called transfer coefficient or electrochemical transfer coefficient or symmetry coefficient (factor)) [i-vi].

In \rightarrow Butler-Volmer equation describing the charge transfer kinetics, the transfer coefficient α (or sometimes symbol β is also used) can range from 0 to 1. The symmetrical energy barrier results in $\alpha = 0.5$. Typically, α is in the range of 0.3 to 0.7. In general, α is a potential-dependent factor (which is a consequence of the harmonic oscillator approximation, see also \rightarrow Marcus theory) but, in practice, one can assume that α is potential-independent, as the potential window usually available for determination of kinetic parameters is rather narrow (usually not more than 200 mV).

The transfer coefficient gives the ratio of the change of the height of the energy barrier the electron has to surmount during charge transfer with respect to the change

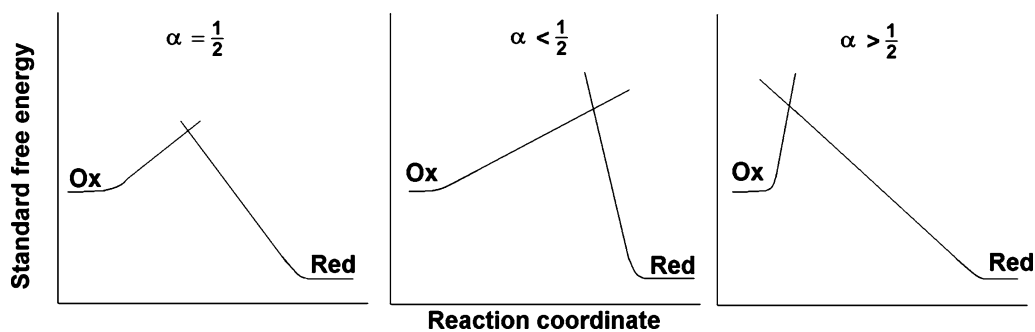

Charge transfer coefficient — Figure 1. Symmetry of energy barriers (the geometry of the intersection region of the free energy curves) for different α charge transfer coefficients (assuming reduction as a forward reaction)

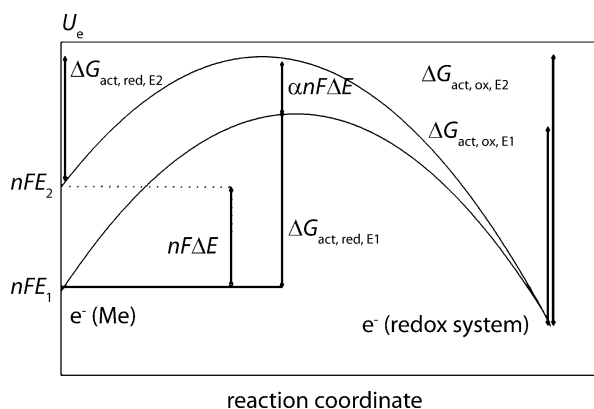

Charge transfer coefficient — Figure 2. Change of the energy barrier for the electron transfer and the effect of a change of electrode potential (for the sake of simplicity it is assumed that the inner electric potential of the solution phase remains unchanged)

of electrode potential ΔE (see \rightarrow *activation overpotential*). A value of $\alpha = 0$ implies no influence of the electrode potential change on the barrier height, $\alpha = 1$ implies that the change of electrode potential causes an exactly equal change of barrier height.

Refs.: [i] Gileadi E (1993) *Electrode kinetics*. VCH, New York, p 53, 127; [ii] Bockris JO'M, Reddy AKN (2006) *Modern electrochemistry*. Springer, New York; [iii] Bard AJ, Faulkner LR (2001) *Electrochemical methods*. Wiley, New York; [iv] Parsons R (1974) *Pure Appl Chem* 37:503; [v] Parsons R (1979) *Pure Appl Chem* 52:233; [vi] Mills I, Cvitas T, Homann K, Kallay N, Kuchitsu K (eds) (1993) *IUPAC quantities, units and symbols in physical chemistry*. Blackwell Scientific Publications, Oxford, p 58, 60

RH, PK, GI

Charge transfer complex — A charge transfer complex is an electron–donor–electron–acceptor \rightarrow *complex*. It is characterized by electronic transition (s) to an

excited state in which there is a partial transfer of electronic charge from the donor molecule to the acceptor moiety. As a consequence a strong charge transfer band is observable in the UV–VIS spectra [i–iv]. Typical molecules are tetracyanoquinodimethane–tetrathiofulvalene, and \rightarrow *quinhydrone*. The \rightarrow *adduct* formed between a Lewis acid and a Lewis base (see \rightarrow *acid–base-theories*, \sim *Lewis*) in a wider sense also belong to this group of compounds. Optical intervalence charge transfer may arise in mixed valence compounds, e.g., metal oxides such as $H_xW_x^V W_{(1-x)}^{VI} O_3$ [v].

Refs.: [i] Moss GP, Smith PAS, Taverner D (1995) *Pure Appl Chem* 67:1328; [ii] Muller P (1994) *Pure Appl Chem* 66:1094; [iii] Atkins PW (1995) *Physical chemistry*. Oxford University Press, Oxford; [iv] Rose J (1967) *Molecular complexes*. Pergamon Press, Oxford, p 596; [v] Monk PMS, Mortimer RJ, Rosseinsky DR (1995) *Electrochromism: fundamentals and applications*, VCH, Weinheim, p 59

GI

Charge transfer kinetics — The \rightarrow *electrode reaction* is an interfacial reaction that necessarily involves a charge transfer step. When the rate is controlled by the charge transfer step we speak of charge transfer kinetics [i–iii]. In respect of the general theory including the fundamental equations we refer to the following entries \rightarrow *Butler–Volmer equation*, \rightarrow *Erdey–Grúz–Volmer equation*, \rightarrow *Frumkin effect*, \rightarrow *irreversibility*, \rightarrow *kinetics*, \rightarrow *Polányi*, \rightarrow *reaction rate*, \rightarrow *reversibility*. The microscopic description of charge transfer is reviewed under the title \rightarrow *Marcus theory*.

Refs.: [i] Bard AJ, Faulkner LR (2001) *Electrochemical methods*. Wiley, New York, pp 87–134; [ii] Inzelt G (2002) *Kinetics of electrochemical reactions*. In: Scholz F (ed) *Electroanalytical methods*. Springer, Berlin, pp 29–48; [iii] Gileadi E (1993) *Electrode kinetics*. VCH, New York, pp 51–124

GI

Charge-transfer overpotential — The essential step of an \rightarrow electrode reaction is the charge (\rightarrow electron or \rightarrow ion) transfer across the phase boundary (\rightarrow interface). In order to overcome the activation barrier related to this process and thus enhance the desirable reaction, an \rightarrow overpotential is needed. It is called charge-transfer (or transfer or electron transfer) overpotential (η_{ct}). This overpotential is identical with the \rightarrow activation overpotential. Both expressions are used in the literature [i–iv].
 Refs.: [i] Bard AJ, Faulkner LR (2001) *Electrochemical methods*. Wiley, New York, pp 87–124; [ii] Erdey-Grúz T (1972) *Kinetics of electrode processes*. Akadémiai Kiadó, Budapest, pp 19–56; [iii] Inzelt G (2002) *Kinetics of electrochemical reactions*. In: Scholz F (ed) *Electroanalytical methods*. Springer, Berlin, pp 29–33; [iv] Hamann CH, Hamnett A, Vielstich W (1998) *Electrochemistry*. Wiley VCH, Weinheim, p 145

Charge transfer reaction — Any \rightarrow electrode reaction is an interfacial (i.e., heterogeneous) reaction that necessarily involves a charge transfer step [i–iv]. The latter can be a neutralization or formation of ions (ion transfer), or alteration of the ionic charge by the gain or loss electrons from or to the metal (\rightarrow electron transfer), respectively. This is the actual electrochemical reaction. Charge transfer can occur not only at solid|liquid interface but practically at any variations of interfaces (e.g., liquid|liquid, solid|solid) causing a chemical change. The charge transfer has to be distinguished from the \rightarrow charge transport. The charge transfer is a microscopic process which may occur both at \rightarrow interfaces and within a single phase. The charge transport takes place within a phase and involves macroscopic long-distance motion, e.g., hydrodynamic movement of ions in solution or electronic conduction in metals. In the literature, charge transfer is often used instead of charge transport, however, this should be discouraged, although in some cases, e.g., extended electron transfer, the distinction is not easy. The charge transfer always results in chemical changes in that the oxidation state of the reacting species changes. It may or may not involve the reorganization of the bonds of the molecules. When only the rearrangement of the solvation sphere or ligands occurs, it is called outer-sphere electron transfer while the process accompanied by bond cleavage or strong interaction between the reactants is called inner-sphere electron transfer [v]. These processes determine the rate of the reaction since the act of the electron transfer itself is very fast, it occurs within 10^{-16} s.

The \rightarrow Marcus theory [vi–vii] gives a unified treatment of both **heterogeneous** electron transfer at electrodes and **homogeneous** electron transfer in solutions.

An important factor is the electron coupling between the electrode metal and the redox species or between the two members of the redox couple. If this coupling is strong the reaction is called adiabatic, i.e., no thermal activation is involved. For instance, electrons are already delocalized between the metal and the redox molecule before the electron transfer; therefore, in this case no discrete electron transfer occurs [see also \rightarrow adiabatic process (quantum mechanics), \rightarrow nonadiabatic (diabatic) process].

Homogeneous charge transfer can take place between chemically similar redox species of one redox couple, e.g., Fe^{3+} and Fe^{2+} ions in solution or ferrocenium and ferrocene moieties in poly(vinylferrocene) films, the electron transfer (\rightarrow electron hopping or electron exchange reaction) can be described in terms of second-order kinetics and according to the \rightarrow Dahms–Ruff theory [viii–x] it may be coupled to the isothermal diffusion:

$$D = D_0 + \frac{k_{\text{ex}} \delta^2 c}{6}, \quad (1)$$

where D is the measured \rightarrow diffusion coefficient, D_0 is the diffusion coefficient in the absence of electron exchange process, k_{ex} is the second-order rate constant of the exchange reaction, c and δ are the concentration and the distance between the centers of the chemically equivalent species involved in the reaction. The first example was the electron exchange in the system $\text{Pb(IV)}/\text{Pb(II)}$ studied [xi] by using isotope labeling.

The \rightarrow prototropic conduction (see also \rightarrow Grotthus mechanism) in acid solutions can be interpreted in a similar way by assuming a proton exchange mechanism (proton transfer or jumping) [xii].

\rightarrow Redox reactions, i.e., when electron exchange occurs, are considered charge transfer reactions in solutions. It is frequently accompanied by the transfer of heavier species (ions). Processes in which charged species react in solutions but no electron exchange takes place, e.g., proton exchange in protonation–deprotonation or acid–base reactions are not called charge transfer reactions.

The activation energy and consequently the rate of redox reactions (k) depend on the charge of the species (z_i), the \rightarrow dielectric permittivity (ϵ) of the solvent, the \rightarrow ionic strength (I), the size of the species, as well as the structural changes of the molecules occurring during the reaction and other possible ion–solvent interactions [xiii].

$$\ln k = \ln k^0 - \frac{N_A z_A z_B e^2}{\epsilon k_B T r}, \quad (2)$$

where k^0 is the rate constant in the absence of an electrostatic effect, z_A and z_B the charge numbers of the reacting species, e is the elementary charge, ϵ is the \rightarrow dielectric permittivity of the solvent, k_B is the \rightarrow Boltzmann constant, T is the temperature, and r is the distance between the ions in the activated complex.

It follows that k decreases when the reacting species have the same sign of charge and increases when cations react with anions, as well as becomes smaller when ϵ decreases.

The increase of the \rightarrow ionic strength (I) will influence the electrostatic interactions (\rightarrow Brønsted's salt effect, \rightarrow Brønsted-Bjerrum equation) which can be taken into account by using the \rightarrow Debye-Hückel theory:

$$\ln k = \ln k^0 + \frac{2z_A z_B A \sqrt{I}}{1 + Ba_i \sqrt{I}}, \quad (3)$$

where A and B are the factors from the Debye-Hückel equation and a_i is the size of the ion.

It should be mentioned that this treatment is valid only for the elementary steps, and the actual form of the reacting species in a given solution is of utmost importance. For instance, in chloride-containing solutions Sn^{2+} ions exist in the form of SnCl_4^{2-} anions.

The mechanism of electron transfer reactions in metal complexes has been elucidated by \rightarrow Taube who received the Nobel Prize in Chemistry for these studies in 1983 [xiv]. Charge transfer reactions play an important role in living organisms [xv-xvii]. For instance, the initial chemical step in \rightarrow photosynthesis, as carried out by the purple bacterium *R. sphaeroides*, is the transfer of electrons from the excited state of a pair of chlorophyll molecules to a pheophytin molecule located 1.7 nm away. This electron transfer occurs very rapidly (2.8 ps) and with essentially 100% efficiency. Redox systems such as ubiquinone/dihydroquinone, \rightarrow cytochrome ($\text{Fe}^{3+}/\text{Fe}^{2+}$), ferredoxin ($\text{Fe}^{3+}/\text{Fe}^{2+}$), \rightarrow nicotinic-adenine-dinucleotide ($\text{NAD}^+/\text{NADH}_2$) etc. have been widely studied also by electrochemical techniques, and their redox potentials have been determined [xviii-xix].

Refs.: [i] Bard AJ, Faulkner LR (2001) *Electrochemical methods*. Wiley, New York, pp 90-94; [ii] Erdey-Grúz T (1972) *Kinetics of electrode processes*. Akadémiai Kiadó, Budapest, pp 19-56; [iii] Gileadi E (1993) *Electrode kinetics*. VCH, New York, pp 106-126; [iv] Inzelt G (2002) *Kinetics of electrochemical reactions*. In: Scholz F (ed) *Electroanalytical methods*. Springer, Berlin, pp 29-44; [v] Miller CJ (1995) *Heterogeneous electron transfer kinetics at metallic electrodes*. In: Rubinstein I (ed) *Physical electrochemistry*. Dekker, New York, pp 27-79; [vi] Marcus RA (1965) *J Chem Phys* 43:679; [vii] Marcus RA (1997) In: Rock PA (ed) *Special topics in electrochemistry*. Elsevier, p 161;

[viii] Inzelt G (1994) In: Bard AJ (ed) *Electroanalytical chemistry*, vol. 18. Marcel Dekker, New York, pp 90-124; [ix] Ruff I, Friedrich VJ (1971) *J Phys Chem* 75:3297; [x] Ruff I, Botár L (1985) *J Chem Phys* 83:1292; [xi] Hevesy G, Zechmeister L (1920) *Berichte* 53:410; [xii] Erdey-Grúz T (1974) *Transport phenomena in aqueous solutions*. Adam Hilger, London, pp 278-289; [xiii] Amis S (1966) *Solvent effects on the reaction rates and mechanism*. Academic Press, New York; [xiv] Taube H (1952) *Chem Rev* 50:126; [xv] Vogel G, Angerman H (1992) *dtv-Atlas zur Biologie*. Deutscher Taschenbuch Verlag, München; [xvi] Oxtoby DW, Gillis HP, Nachtrieb NH (1999) *Principles of modern chemistry*. Saunders College Publ, Fort Worth, pp 612, 845-848; [xvii] Bianco C (2002) In: Bard AJ, Stratman M, Wilson GS (eds) *Bioelectrochemistry*. *Encyclopedia of electrochemistry*, vol. 9. Wiley-VCH, Weinheim, pp 1-9; [xviii] Inzelt G (2006) *Standard, formal, and other characteristic potentials of selected electrode reactions*. In: Bard AJ, Stratmann M, Scholz F, Pickett CJ (eds) *Inorganic chemistry*. *Encyclopedia of electrochemistry*, vol. 7a. Wiley-VCH, Weinheim; [xix] Brajter-Toth A, Chambers JQ (eds) (2002) *Electroanalytical methods for biological materials*. Marcel Dekker, New York

GI

Charge transfer resistance — At low \rightarrow overpotentials ($\eta \ll RT/nF$) none of the \rightarrow partial current densities is negligible (see also \rightarrow activation overpotential, \rightarrow charge-transfer overpotential, \rightarrow Butler-Volmer equation).

In this case the exponential relationship between the \rightarrow current density j and the overpotential η (j_a and η and j_c and η , respectively) can be expanded into a series, and since $\exp x \approx 1 + x$ when $x \ll 1$

$$j = j_0 \frac{nF}{RT} \eta. \quad (1)$$

Equation (1) is similar to \rightarrow Ohm's law, thus we may define a resistance that is called charge transfer resistance (R_{ct}) [i-iii]:

$$R_{ct} = \frac{RT}{nF j_0}. \quad (2)$$

The unit of R_{ct} is $\Omega \text{ cm}^2$. R_{ct} is also called activation resistance. It follows from Eq. (1) that the higher is j_0 , the smaller is R_{ct} . R_{ct} can be calculated also at different potentials far from the equilibrium which is a general practice in \rightarrow electrochemical impedance spectroscopy. It is based on the concept that at small signal perturbation ($< 5 \text{ mV}$) the response is essentially linear. R_{ct} values are obtained either from the diameter of the \rightarrow Randles semicircle or from the angular frequency (ω) at which Z'' exhibits a maximum vs. Z' :

$$\omega_{\max} = \frac{1}{R_{ct} C_d}, \quad (3)$$

where C_d is the \rightarrow double-layer capacitance.

Refs.: [i] Bard AJ, Faulkner LR (2001) *Electrochemical methods*. Wiley, New York, pp 102, 368–387; [ii] Inzelt G (2002) *Kinetics of electrochemical reactions*. In: Scholz F (ed) *Electroanalytical methods*. Springer, Berlin, pp 29–33; [iii] Retter U, Lohse H (2002) *Electrochemical impedance spectroscopy*. In: Scholz F (ed) *Electroanalytical methods*. Springer, Berlin, pp 149–156

Charge transport — When charged species move within a phase, this is called charge transport [i–viii]. Electron transport occurs in metals and → *semiconductors*. (In the latter case the → *charge carriers*: → *holes*, → *polarons*, → *bipolarons* (→ *electronic defects*) are also considered as moving charged species, while the → *superconductivity* occurring at very low temperatures is explained by → *Cooper pairs* which are formed by two electrons.) Although the → *conductivity* of the electronically conducting phase is a critical factor in all electrochemical experiments and applications, electrochemists are mostly interested in the ionic charge transport in electrolyte solutions or surface layers [i–iii]. Mixed, electronic and ionic conductivity occurs, e.g., in → *polymer-modified electrodes* [ix], and in many → *solid electrolytes* (see also → *mixed ionic–electronic conductor*).

In metals the electrons move with a constant speed since although they are accelerated by the electric field (**E**) the collision with the metal ions causes an energy loss. The direction of the movement of electrons is opposite to **E**, and the value of the speed of the physical movement of the electrons is several mm s^{-1} , e.g., in copper 0.371 mm s^{-1} , i.e., it is smaller than the thermal motion. Current starts immediately after joining the current source to the circuit, since the electric field travels at the speed of light in the conductor. In metals the conductivity decreases with increasing temperature [iv]. In → *semiconductors* electron conduction is predominant in n-type semiconductors, and therefore, electrons are the majority charge carriers and holes are minority charge carriers. On the other hand, in p-type semiconductors holes are the majority charge carriers and conduction by electrons is of lesser scale. Charge carriers may originate from the atoms in the crystal lattice or be injected from outside. Conduction electrons may also be released by absorption of radiation (photoeffect) [v–viii].

Since the → *migration* of charge carriers occurs in a crystal lattice, a friction arises, and the situation is similar to the transport of ionic species in viscous fluids.

In electrolyte solutions or melts the charge transport is mostly ionic. Ions can move under the influence of concentration gradient (diffusion). In the case

of → *diffusion* of electrolytes both positively and negatively charged ions move in the same direction. The excess ions generated in an electrode reaction move away from the electrode or when ions consumed in an electrode reaction the same type of ions enter the interfacial region from the bulk solution.

GI In the bulk electrolyte solution the current is related to the motion of ions under the influence of the electric field (potential gradient); the diffusion plays a minor role, if any, because the concentration gradient is usually small in the bulk phase. Near the electrode, the charged reacting species are, in general, transported by both diffusion and migration, however, the latter process is not always detectable. Since → *anions* move towards the → *anode* and → *cations* towards the → *cathode*, the migrational and diffusional fluxes may be opposite. The transport of ions in liquid phase has been elucidated on the basis of phenomenological, as well as molecular theories [ii]. For a more detailed description and the respective relationships see → *conductance*, → *conductor*, → *Debye–Falkenhagen effect*, → *diffusion*, → *electrokinetic effect*, → *electron transport chain*, → *ion*, → *ion transport through membranes*, → *ionic conductors*, → *ionic current*, → *Kohlrausch’s square root law*, → *mass transport*, → *mobility*, → *Nernst–Einstein equation*, → *Nernst–Planck equation*, → *Ohm’s law*, → *transport*, → *transport number*, → *Wien effect*.

In solutions and also in solids electron or proton transport may be coupled to the ionic charge transport via electron exchange reactions (→ *electron hopping* or electron transfer reaction) or proton jumping (see → *charge transfer reaction*).

Ionic conductivity may occur also in solids [x]. Ionic species of the solid can migrate along the channels of the rigid framework. For example, such a → *solid electrolyte* is RbAg_4I_5 . The most important applications of oxide ion conductors are in → *solid oxide fuel cells* and → *oxygen gas sensors*. There are glassy electrolytes, e.g., $\text{Li}_2\text{S} - \text{P}_2\text{S}_5$ in which Li^+ ions can move. An important class is the → *polymer electrolytes* in which salts are dissolved in polymer [e.g., poly(ethylene oxide)]. In the case of intercalation compounds ions also move between the layers, e.g., of → *graphite*. Both ion and electron transports play an important role in living organisms [xi–xii].

Refs.: [i] Ibl N (1981) *Pure Appl Chem* 53:1827; [ii] Erdey-Grúz T (1974) *Transport phenomena in aqueous solutions*. Adam Hilger, London, pp 278–289; [iii] Komorsky-Lovrić Š (2002) *Electrolytes*. In: Scholz F (ed) *Electroanalytical methods*. Springer, Berlin, pp 279–287; [iv] Breuer H (1988) *dtv-Atlas zur Physik*. Deutscher Taschenbuch Verlag, München; [v] Sato N (1998) *Electrochemistry at metal and semiconductor elec-*

trodes. Elsevier, Amsterdam; [vi] Bard AJ, Memming R, Miller B (1991) *Pure Appl Chem* 63:569; [vii] Bockris JO'M, Khan SUM (1979) *Quantum electrochemistry*. Plenum Press, New York, pp 291–375; [viii] Gurevich YuYa, Pleskov YuV, Rotenberg ZA (1980) *Photoelectrochemistry*. Consultants Bureau, New York; [ix] Inzelt G (1994) In: Bard AJ (ed) *Electroanalytical chemistry*, vol. 18. Marcel Dekker, New York, pp 89–241; [x] Bruce PG (1995) In: Bruce PG (ed) *Solid state electrochemistry*. Cambridge University Press, Cambridge, pp 1–6; [xi] Brett CMA, Oliveira Brett AM (1993) *Electrochemistry*. Oxford University Press, Oxford, pp 367–391; [xii] Ti Tien H, Ottova A (2002) *Membrane electrochemistry*. In: Bard AJ, Stratman M, Wilson GS (eds) *Bioelectrochemistry*. *Encyclopedia of electrochemistry*, vol. 9. Wiley-VCH, Weinheim, pp 513–556

Charging current — There are two, rather different meanings of charging current in electrochemistry. First, it is used for the capacitive current that charges the electrochemical → *double layer*. Second, it is the current applied to a → *secondary cell* (storage → *battery*) to restore its → *“capacity”*, i.e. supplying electric energy for conversion to stored chemical energy. In the latter case oxidation and reduction reactions occur at the respective electrodes, resulting in chemical changes, and the cell returns to approximately original condition. We deal with the double-layer charging, in more detail, below.

The electrode|solution → *interface* (→ *interphase*) behaves like a capacitor, and a model of the → *interfacial region* somewhat resembling a capacitor can be given. In the case of → *ideally polarized* (or ideally polarizable) *electrode* only this charging current will flow on changing the → *electrode potential* by using an external current source. There is no → *charge transfer* across the interface, only charge separation occurs, i.e., either an excess or a deficiency of electrons is achieved at the metal, and the concentration distribution of ions in the solution near to the metal, i.e., in the electrochemical (electrical) double layer will change (see: nonspecifically adsorbed ions in → *adsorption*) in such a way that the opposite charges at the metal (Q^M) and solution (Q^S) sides compensate each other ($Q^M = -Q^S$ or by using the charge densities $\sigma^M = -\sigma^S$).

For changing the potential (E) across a capacitor a supply of a certain amount of charge (Q) is needed. The amount of charge depends on the → *capacitance* of the capacitor (C) and the potential difference established during charging. During this charging process a current called the charging or → *capacitive current* (I_c) will flow.

This charging current will always flow when the potential is varied independently from a possible simulta-

neously occurring charge transfer (→ *Faraday process*) across the interface.

For the sake of simplicity usually the charging and the Faraday processes are treated independently, however, it is justified only in certain cases. This approximation is valid if a high excess of supporting electrolyte is present, i.e., practically only nonreacting ions build up the double layer at the solution side. In modelling the electrode → *impedance* almost always an → *equivalent circuit* is used in that the → *double-layer impedance* and the → *faradaic impedance* are in parallel which is true only when these processes proceed independently.

GI Because the value of double-layer capacitance (C_d) is usually between 10–80 $\mu\text{F cm}^{-2}$, the charge needed to change the potential of an electrode (see: real → *electrode surface area*, $A = 1 \text{ cm}^2$) by 1 V is 10–80 μC . However, it should be noted that C_d is potential dependent.

The time (t) dependences of the charging current (I_c) of a cell where the capacitance of the electrode investigated is much smaller than that of the reference electrode (e.g., saturated calomel electrode) and the counter electrode (e.g., high surface area of platinum electrode) as well as the geometrical capacitance of the cell are neglected, therefore the total capacitance of the cell is equal to the capacitance of the electrode (C_d) under study, and → *ohmic* (solution) *resistance* is R_s , – are as follows.

1. Potential step measurement

$$I_c = \frac{E}{R_s} \exp[-t/R_s C_d]$$

(Note that this equation can also be used concerning the whole instrumentation – potentiostat – which also has a time constant, $\tau = RC$.)

2. Linear potential sweep

$$I_c = \nu C_d [1 - \exp(-t/R_s C_d)]$$

if $Q = 0$ at $t = 0$, and ν is the → *scan rate*.

For triangular waves (→ *cyclic voltammetry*) the steady-state current changes from νC_d during the forward scan (increasing E) to $-\nu C_d$ during the reverse (decreasing E) scan.

When the $R_s C_d$ circuit is charged by a constant current (current step experiment) the potential increases linearly with time:

$$E = I(R_s + t/C_d) .$$

Such an equation can be applied for the determination of → *pseudocapacitances* (e.g., hydrogen capacitance of a platinum electrode) in the case of the so-called charging curve experiments.

Refs.: [i] Bard AJ, Faulkner LR (2001) *Electrochemical methods*. Wiley, New York, pp 11–18; [ii] Oldham HB, Myland JC (1994) *Fundamentals of electrochemical science*. Academic Press, San Diego, pp 328–354; [iii] Inzelt G (2002) *Kinetics of electrochemical reactions*. In: Scholz F (ed) *Electroanalytical methods*. Springer, Berlin, pp 45, 139; [iv] Stojek Z (2002) *Pulse voltammetry*. In: Scholz F (ed) *Electroanalytical methods*. Springer, Berlin, pp 100, 109; [v] Parsons R (1974) *Pure Appl Chem* 37:503; [vi] Trasatti S, Petrii OA (1991) *Pure Appl Chem* 63:711; [vii] Sluyters-Rehbach M (1994) *Pure Appl Chem* 66:1831

Charging current, elimination of — In practically all analytical applications of voltammetric techniques the elimination of the \rightarrow charging (capacitive) current (I_c) is an important requirement to decrease the limit of detection, provided that the analytical signal is a faradaic current. In fundamental studies the elimination of capacitive currents is frequently necessary for isolation of the faradaic signals.

The contribution of the charging (capacitive) current can be eliminated following the measurement of the net current, e.g., by subtraction of I_c from the measured current (I) which is the sum of the capacitive current (I_c) and the \rightarrow charge transfer (faradaic) current (I_F), i.e., $I_F = I - I_c$. The variation of I_c in the course of \rightarrow potential step or \rightarrow cyclic voltammetric experiments can be determined to execute the experiments under the same conditions but in a pure \rightarrow supporting electrolyte, i.e., in the absence of the electrochemically active species studied and under conditions that the electroactive substance does not appreciably change the double-layer capacitance. Such a treatment is inevitable in fast scan rate \rightarrow voltammetry because in this case I_c may be higher than I_F , since the former is proportional to the scan rate (v), while I_F to $v^{1/2}$. To derive reliable quantities in the case of potential step techniques, e.g., for the \rightarrow diffusion coefficient, it is a useful strategy to consider only the data obtained at longer times when the current-time function obeys the \rightarrow Cottrell-equation, or its integrated form obeys the theoretically expected chronocoulometric curves (\rightarrow chronocoulometry).

The elimination of the capacitive current in the case of \rightarrow differential pulse voltammetry (DPV) is achieved by sampling the current twice: before pulse application and at the end of the pulse. The basis for that elimination is the very different time dependence of both current components: I_c exponentially dropping with time, and I_F decreasing with $t^{-1/2}$, at least in reversible cases (\rightarrow Cottrell equation).

In classical \rightarrow DC-polarography by using a \rightarrow dropping mercury electrode (DME) the charging current can

make the residual current rather large because the DME is always expanding, new surface develops continuously, consequently, a charging current is always required. The usual strategies are as follows. First, the ratio of faradaic current/capacitive current is increased by applying the reactant with a concentration higher than 10^{-5} mol dm $^{-3}$. Second, a graphical extrapolation of the baseline residual current is carried out. This treatment is based on the almost linear potential dependence of the charging current on the potential. The third method is the utilization of the time (t) dependence by current sampling at different times since the charging current decreases monotonically as $t^{-1/3}$, and has a minimal value at the drop time, t_{\max} [i–iii].

Refs.: [i] Bard AJ, Faulkner LR (2001) *Electrochemical methods*. 2nd edn. Wiley, New York, pp 270–272, 291–293; [ii] Stojek Z (2002) *Pulse voltammetry*. In: Scholz F (ed) *Electroanalytical methods*. Springer, Berlin, p 109; [iii] Inzelt G (2002) *Chronocoulometry*. In: Scholz F (ed) *Electroanalytical methods*. Springer, Berlin, pp 137–148

GI

Chelate — A cyclic \rightarrow coordination entity formed between a central chemical species (frequently a metal ion) and at least one \rightarrow ligand with two or more separate functional groups bonded to the central chemical species. The use of the term is often restricted to organic molecules bonded by two or more binding sites to metallic central atoms [i, ii]. Chelates possess a comparable high stability because of an \rightarrow entropy (entropic) effect caused by the liberation of a larger number of solvent molecules than the \rightarrow chelating agents that are forming the complex (chelate). This increment in the overall number of entities increases the entropy of the system and leads to a very negative standard \rightarrow Gibbs energy of complex formation. Thus, chelate formation is entropy driven. The term ‘chelate’ is derived from the Greek word for the claw of a crawfish, as the \rightarrow ligand grasps the metal ion like a crawfish his catch with his claws [iii].

Refs.: [i] Muller P (1994) *Pure Appl Chem* 66:1077; [ii] Cotton FA, Wilkinson G, Murillo CA, Bochmann M (1999) *Advanced inorganic chemistry*. Wiley-Interscience, New York; [iii] Morgan GT, Drew HDK (1920) *J Chem Soc* 117:1456

FG

Chelating agent — A \rightarrow ligand with two or more separate functional groups capable of forming a cyclic \rightarrow coordination entity, the \rightarrow chelate, with other chemical species [i]. The number of binding sites of a single chelating agent is indicated by the adjectives bidentate, tridentate, tetradentate, etc. [ii].

Refs.: [i] Muller P (1994) *Pure Appl Chem* 66:1077; [ii] De Bolster MWG (1997) *Pure Appl Chem* 69:1251

Chemelec cell — An electrolytic cell with electrodes (both anode and cathode) made from expanded metal or simple metal plates. The cell is filled with inert particles, which are floated when the electrolyte solution enters the cell from the bottom. This causes effectively turbulence with increased \rightarrow mass transport. This cell is employed in wastewater treatment especially from galvanic operations.

CHEMFET — Chemically sensitive field effect transistor. Active electronic solid state component based on a field effect transistor (FET) with added chemical functionality mostly effected by coating the gate of the FET with a substance providing the desired functionality (e.g., a material acting as an ion exchanger with protons resulting in a pH-sensitive FET (pH-FET) or with potassium ions resulting in a potassium-sensitive FET (K-ISFET), a material (e.g., palladium coating) responding to dissolved gas (GASFET)). The current flowing between the two electrodes in the FET (source and drain) is controlled by the electrostatic effects of the species interacting with the modifying layer on the gate. The bias of the device is adjusted with an external electronic circuit employing a reference electrode (see also \rightarrow REFET).

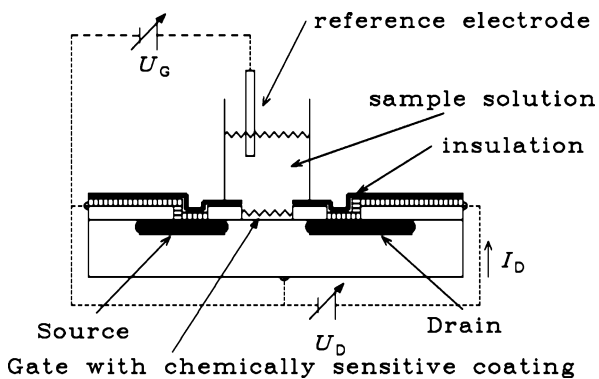

CHEMFET — Figure

Refs.: [i] Oehme F (1991) In: Göpel W, Hesse J, Zemel JN (eds) *Sensors, chemical and biochemical sensors, part I, vol. 2*. VCH, Weinheim; [ii] Janata J, Huber RJ (1979) *Ion-Selective Electrode Rev* 1:31

Chemical potential — Symbol: μ_i , SI unit: J mol^{-1} . The chemical potential of species i in a thermodynamic system is defined as the partial derivative of the \rightarrow Gibbs

energy (G) (free energy), \rightarrow Helmholtz free energy (F_H), or \rightarrow internal energy (U_E) with respect to the number of these species N_i :

$$\begin{aligned}\mu_i &\equiv \left(\frac{\partial G}{\partial N_i} \right)_{T,P,Q,N_{j \neq i}} \\ \mu_i &\equiv \left(\frac{\partial F_H}{\partial N_i} \right)_{T,V,Q,N_{j \neq i}} \\ \mu_i &\equiv \left(\frac{\partial U_E}{\partial N_i} \right)_{S,V,Q,N_{j \neq i}}.\end{aligned}$$

For condensed systems such as solid materials, the first two definitions can both be used as the energy associated with mechanical work (PdV) is usually negligible. The condition of fixed \rightarrow entropy may hardly be achieved in real systems.

The chemical potential of a component is usually expressed in the form

$$\mu_i = \mu_i^\ominus + RT \ln a_i,$$

where a_i is the relative \rightarrow activity, and μ_i^\ominus is the concentration-independent part determined by properties of the component, temperature, and/or total pressure, i.e., the standard chemical potential. For many elements and compounds, the values of the molar Gibbs energy and μ_i^\ominus are tabulated by IUPAC [i].

The physical meaning of the chemical potential relates to the amount by which the \rightarrow energy of a system would change when one additional particle i is introduced at fixed temperature and total pressure or volume (or entropy). The chemical potential is one part of the \rightarrow electrochemical potential. The chemical potential is equal to the electrochemical potential for neutral species or an electrolyte (neutral combination of charged ions), and for a pure phase (e.g., a metal, AgCl) the electrochemical potential is equal to the standard chemical potential.

Chemical potential of any charged species, such as \rightarrow ions, cannot be explicitly separated from those of other components of the system.

This quantity has a key significance for \rightarrow electrochemistry and irreversible \rightarrow thermodynamics, and it is used for the description of most transport-related processes and chemical reactions [ii–iv]. For \rightarrow equilibrium under zero electrical and magnetic fields

$$\sum_i \mu_i \nu_i = 0.$$

Beside the chemical potential of an electrolyte B (μ_B) the mean chemical potential (μ_{\pm}), i.e., the average part of

the chemical potential per ion can also be defined:

$$\mu_{\text{B}}/\nu = \mu_{\pm} = \mu_{\text{B}}^{\ominus}/\nu + RT \ln a_{\text{B}}^{1/\nu}.$$

(See also → *activity*, → *activity coefficient*).

The equilibrium conditions in electrochemical systems are usually expressed in terms of electrochemical potentials. For non-equilibrium systems, the gradient of chemical and/or electrochemical potential is a driving force for flux of particles *i*. See also → *Wagner equation*, → *Wagner factor* and → *ambipolar conductivity*, → *Onsager relations*.

Notice that other definitions of chemical potential may sometimes appear in literature, particularly in the density functional theory (where the electronic chemical potential is considered as the **functional derivative** of the density **functional** with respect to the **electron density**), and also in the description of relativistic systems in theoretical physics (see [v, vi] and references cited).

Refs.: [i] Mills I, Cvitas T, Homann K, Kallay N, Kuchitsu K (eds) (1993) *IUPAC quantities, units and symbols in physical chemistry*. Blackwell, London, p 49; [ii] Levine IN (1995) *Physical chemistry*, 4th edn. McGraw-Hill, New York; [iii] Wagner C (1966) *The electromotive force of galvanic cells involving phases of locally variable composition*. In: Delahay P, Tobias CW (eds) *Advances in electrochemistry and electrochemical engineering*. Wiley-Interscience, New York; [iv] Denbigh KG (1951) *The thermodynamics of the steady state*. Wiley, New York; [v] Burke K, Werschnik J, Gross EKV (2005) *J Chem Phys* 123:062206; [vi] Tipler P, Llewellyn R (2002) *Modern physics*, 4th edn. WH Freeman, New York

VK

Chemically modified electrodes (CME) — According to IUPAC, “the distinguishing feature of a CME is that a generally quite thin film (from monomolecular to perhaps a few micrometers-thick multilayer) of a selected chemical is bonded to or coated on the electrode surface to endow the electrode with the chemical, electrochemical, optical, electrical, transport, and other desirable properties of the film in a rational, chemically designed manner.”

CMEs are made by using one of the following methods: chemisorption (when molecules of modifying species are attached by valence forces), covalent bonding, coating by polymer (organic), polynuclear (inorganic) or mixed (composite, hybrid organic-inorganic) films, or by mixing the modifier with electrode matrix material. CMEs covered with polymer films (e.g., with redox polymers, → *conducting polymers*, and polynuclear inorganic compounds) are the most popular systems, because of their numerous advantages (simplicity of preparation, stability, well-defined

or sizeable electrochemical responses). CMEs can be further divided according to the nature of the coating process:

- Cross-linking. The chemical components are coupled to an electrode substrate to impart a desired property to the film.
- Dip coating. The electrode substrate is immersed in polymer solution for a given period of time.
- Electrochemical deposition (redox deposition). The electrode substrate is immersed in solution of the polymer and subject to electrochemical treatment. Used when oxidation or reduction of polymer decreases polymer solubility, resulting in polymer layer on electrode substrate.
- Electrochemical polymerization. The electrode substrate is immersed in monomer solution and subject to electrochemical treatment. The monomers are oxidized or reduced to an activated form which polymerizes on electrode surface.
- Radiofrequency polymerization. Vapors of the monomer are exposed to radio frequency plasma discharge.
- Solvent evaporation. The droplet of polymer solution is applied to the electrode substrate and allowed to dry.
- Spin coating (spin casting). As solvent evaporation, but electrode surface is rotated when polymer solution is applied.

Coating by polymer film can be a multi-step process, e.g., to produce multi-layered systems or to further functionalize and to improve usability.

The polymer type films can be characterized for:

- Stability in terms of 1) resistance to degradation or dissolution in aqueous and nonaqueous media, 2) bond strength between the redox sites and polymer matrix, and 3) adherence between the polymer film and the electrode surface.
- Permeability of the polymer to the reaction substrate and products, ionic components, and solvent. Some polymer films also exhibit selective permeability (→ *permselectivity*) to species of different sizes or charges.
- Site population, i.e., the concentration of some designated chemical sites in polymer film.

- Conductivity (electronic, ionic), and the mechanism of charge propagation.
- Reactivity (e.g., → *electrocatalysis*, → *corrosion* protective properties)
- Chromic properties (→ *electrochromism*, electrochemically induced chemiluminescence).

More complex structures of CMEs also exist. They may contain more than one modifying substance, or more than one layer. Such a system can be called a micro- or nano-structured electrode, or integrated chemical system electrode.

See also → *Surface modified electrodes*.

Ref.: [i] Durst RA, Baumner AJ, Murray RW, Buck RP, Andrieux CP (1997) *Pure Appl Chem* 69:1317

PK, AL

Chemically sensitive field effect transistor → *CHEM-FET*

Chemical reaction — A process that results in the interconversion of → *chemical species*. Chemical reactions may be elementary reactions or stepwise reactions. (This definition includes experimentally observable interconversions of conformers.) Detectable chemical reactions normally involve → *molecular entities*, as indicated by this definition, but it is often conceptually convenient to use the term also for changes involving single molecular entities (i.e., “microscopic chemical events”). See also → *identity reaction*.

Ref.: [i] Muller P (1994) *Pure Appl Chem* 66:1077

WK

Chemical reactions in electrochemistry — Chemical reactions accompanying electrochemical reactions, i.e., reactions where either electrons or ions or both are transferred between different phases.

Catalytic reactions in electrochemistry — When the product of an electrochemical reduction reaction is regenerated by a chemical reoxidation, or when the product of an electrochemical oxidation is regenerated by a re-reduction, the regeneration reaction is called a catalytic reaction. For thermodynamic reasons the chemical oxidant (or the reductant) has to be electrochemically irreversible in the potential range where the catalyst is electroactive. The reduction of Ti(IV) in the presence of hydroxylamine is an example for an oxidative regeneration [i, ii]:

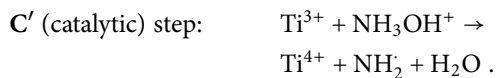

Here Ti^{3+} is the catalyst for the reduction of hydroxylamine.

Coupled homogeneous reactions in electrochemistry — Chemical reactions occurring in an electrochemical cell, in which the electroactive compounds undergo chemical transformation by reacting with the electroinactive compounds, are known as coupled homogeneous reactions. All the compounds in the system are present together in the same phase → *EC*, *CE*, and *EC'* reactions.

Homogeneous reactions in electrochemistry —

Reactions where all reacting substances are present in the same phase, usually in a solution.

Preceding reactions in electrochemistry —

These are reactions where the electroactive compound is formed in a chemical reaction that precedes the electron transfer step. Classical example for preceding reaction is the reduction of formaldehyde to methanol, where the formaldehyde is formed by dehydration (water abstraction) of methan-di-ol [i]:

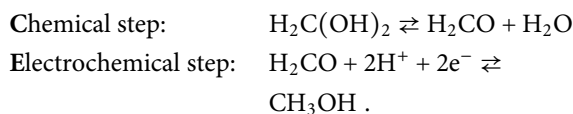

Another example is the reduction of Cd(II) (at mercury electrode) in buffered solutions containing excess of nitrioloacetic acid (NTA) [i, ii]:

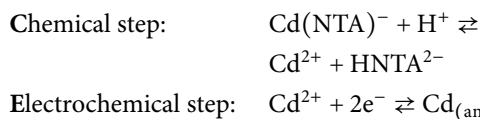

Subsequent reactions in electrochemistry —

Follow-up reaction of the product of an electrochemical reaction, usually producing a species that is not electroactive at potentials where the redox process of the electroactive couple occurs. The oxidation of ascorbic acid, followed by hydration of the product is one representative example for this type of reactions [i, ii]

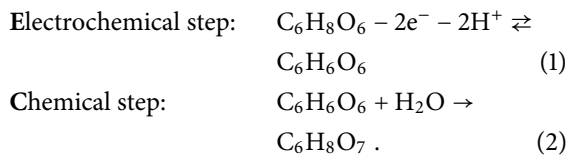

Refs.: [i] Bilewicz R, Wikel K, Osteryoung R, Osteryoung J (1989) *Anal Chem* 61:965; [ii] Bard AJ, Faulkner L (2001) *Electrochemical methods*. Wiley, New York, pp 471–533

RG

Chemical species — is an ensemble of chemically identical molecular entities that can explore the same set of molecular energy levels on the time scale of the experiment. The term is applied equally to a set of chemically identical atomic or molecular structural units in a solid array. For example, two conformational isomers may be interconverted sufficiently slowly to be detectable by separate NMR spectra and hence to be considered to be separate chemical species on a time scale governed by the radiofrequency of the spectrometer used. On the other hand, in a slow chemical reaction the same mixture of conformers may behave as a single chemical species, i.e., there is virtually complete equilibrium population of the total set of molecular energy levels belonging to the two conformers.

Except where the context requires otherwise, the term refers to a set of \rightarrow *molecular entities* containing isotopes in their natural abundance. The wording of the definition given in the first paragraph is intended to embrace both cases, such as graphite, sodium chloride, or a surface oxide, where the basic structural units may not be capable of isolated existence, as well as those cases where they are. In common chemical usage, generic and specific chemical names (such as \rightarrow *radical* or hydroxide ion) or chemical formulae refer either to a chemical species or to a molecular entity.

Ref.: [i] Muller P (1994) *Pure Appl Chem* 66:1077

WK

Chemisorption \rightarrow adsorption

Chemisorption of hydrogen — Process leading to the formation of strongly bound (chemisorbed) hydrogen atoms on an adsorbent (mostly on metal) either via the dissociative adsorption of molecular hydrogen (H_2) or, in the case of electrified interfaces, by charge transfer process occurring, for instance, with H^+ (H_3O^+) or H_2O species

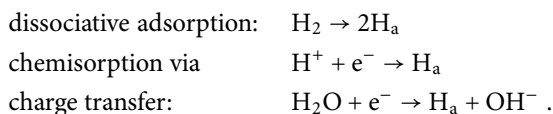

A significant coverage with respect to H_a can be attained on some noble metals (Pt, Pd, Rh). Chemisorbed hydrogen plays a key role in many electrocatalytic processes (\rightarrow *hydrogen evolution*, \rightarrow *electrocatalysis*, electrohydrogenation).

Chemisorption of hydrogen on platinum metals is a reversible process as demonstrated by the symmetry of the cyclic voltammetric curves (\rightarrow *voltammetry*). The voltammetric behavior of these systems depends on the

surface state (roughness, crystallographic faces) of the electrodes. The extent of chemisorption can be determined from the \rightarrow *voltammograms*.

Refs.: [i] Conway BE (1999) *Electrochemical processes involving H adsorbed at metal electrode surfaces*. In: Wieckowski A (ed) *Interfacial electrochemistry, theory, experiment, and applications*. Marcel Dekker, New York, pp 131–150; [ii] Climent V, Gómez R, Orts JM, Rodes A, Aldaz A, Feliu JM (1999) *Electrochemistry, spectroscopy, and scanning tunneling microscopy images of small single-crystal electrodes*. In: Wieckowski A (ed) *Interfacial electrochemistry, theory, experiment, and applications*. Marcel Dekker, New York, pp 463–475; [iii] Calvo EJ (1986) *Fundamentals. The basics of electrode reactions*. In: Bamford CH, Compton RG (eds) *Comprehensive chemical kinetics*, vol. 26. Elsevier, Amsterdam, pp 1–78

GH

Chemisorption of oxygen — Process leading to the formation of strongly bound chemisorbed oxygen atoms on an adsorbent (mostly metal) either via the dissociative adsorption of molecular oxygen (O_2)

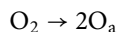

or by a charge transfer process, for instance, by the anodic reaction of H_2O molecules or OH^- ions. In the case of aqueous interfaces chemisorbed oxygen could be in the state of adsorbed OH or O. In contrast to \rightarrow *chemisorption of hydrogen* chemisorption of oxygen at noble metal electrodes is an irreversible process as seen by the asymmetry of the anodic and cathodic branches of the \rightarrow *voltammograms*.

Refs.: [i] Koryta J, Dvořák J, Kavan L (1993) *Principles of electrochemistry*. Wiley, Chichester; [ii] Calvo EJ (1986) *Fundamentals. The basics of electrode reactions*. In: Bamford CH, Compton RG (eds) *Comprehensive chemical kinetics*, vol. 26. Elsevier, Amsterdam, pp 1–78; [iii] Jerkiewicz G (1999) *Surface oxidation of noble metal electrodes*. In: Wieckowski A (ed) *Interfacial electrochemistry, theory, experiment, and applications*. Marcel Dekker, New York, pp 559–576

GH

Chlor-alkali production — With a 63% production volume of the total world chlorine capacity of about 43.4 million tons (in 1998), the chlor-alkali (or chlorine-caustic) industry is one of the largest electrochemical technologies in the world. Chlorine, Cl_2 , with its main co-product sodium hydroxide, NaOH, has been produced on industrial scale for more than a century by \rightarrow *electrolysis* of brine, a saturated solution of sodium chloride (\rightarrow *alkali chloride electrolysis*). Today, they are among the top ten chemicals produced in the world. Sodium chlorate ($NaClO_3$) and sodium hypochlorite ($NaOCl$, “bleach”) are important side products of the

electrogenerated chlorine and caustic. With nearly unchanged demand over the past 20 years, the world capacity of sodium chlorate of about 2.8 million short tons (1998), is with its majority (of about 93% in 1998) used for bleaching purposes in the pulp and paper industry. The quality (purity) as well as chemical composition of the main and side products is strongly depending on the technical production routes, namely, mercury, diaphragm, and membrane (cell) process (see \rightarrow *alkali chloride electrolysis* for details). The mercury process was predominant in Europe and the diaphragm process – in Northern America, while the membrane process has been installed especially in Japan since the 1980s. The use of mercury demands measurements to prevent environmental contamination. At the end of the 1990s, the discharges to the atmosphere conformed with the standards fixed at 0.2 g of mercury per ton of chlorine produced. Increasingly, chlorine producers are moving towards membrane technology, which combines the advantages of lower energy consumption, a very high quality caustic soda, as well as environmental safety.

Refs.: [i] *Chlorine Industry Review 2004–2005*, EuroChlor; [ii] *Bommaraju TV, O'Brien TF (2005) Handbook of chlor-alkali technology*, 5 vols. Springer, Berlin

MHer

Chromatopolarography \rightarrow Kemula

Chromic acid batteries \rightarrow *batteries* in which chromium(VI) (i.e., in acidic chromate solutions) is reduced on an inert electrode and the second electrode is made of an oxidizable metal.

FS

Chromophore — The part (atom or group of atoms) of a \rightarrow *molecular entity* in which the electronic transition responsible for a given spectral band is approximately localized. The term arose in the dyestuff industry, referring originally to the groupings in the molecule that are responsible for the dye's color.

Ref.: [i] *Muller P (1994) Pure Appl Chem 66:1077*

WK

Chronoamperometry — Chronoamperometry belongs to the family of step techniques [i–iv]. In chronoamperometry the \rightarrow *current* is measured as a function of time after application of a \rightarrow *potential step* perturbation. If the potential is stepped from E_1 , where no current flows, i.e., the oxidation or reduction of the electrochemically active species does not take place, to E_2 where the current

belongs to the \rightarrow *electrode reaction* is limited by \rightarrow *diffusion*, the \rightarrow *current* flows at any time after application of the potential step will obey the \rightarrow *Cottrell equation* [i–iv].

In contrast to steady-state conditions, the current decreases with time because the concentration gradient decreases:

$$\partial c(x, t) / \partial x = c^* (\pi D t)^{-1/2} \exp(-x^2 / \pi D t) \quad (1)$$

$$[\partial c(x, t) / \partial x]_{x=0} = c^* (\pi D t)^{-1/2}, \quad (2)$$

where x is the location, t is time, D and c^* are the \rightarrow *diffusion coefficient* and bulk concentration of the reacting species.

The perturbation and the current response as well as the \rightarrow *capacitive current* (I_c) at short times are shown schematically in Fig. 1.

For fast charge transfer the \rightarrow *diffusion current* will change with $t^{-1/2}$:

$$I(t) = nFAD_R^{1/2} c^* (\pi t)^{-1/2} \left\{ 1 + (D_O/D_R)^{1/2} \times \exp \left[(nF/RT)(E - E_c^{\ominus'}) \right] \right\}^{-1}, \quad (3)$$

where $E_c^{\ominus'}$ is the formal electrode potential. If the potential is stepped to the diffusion limiting current region,

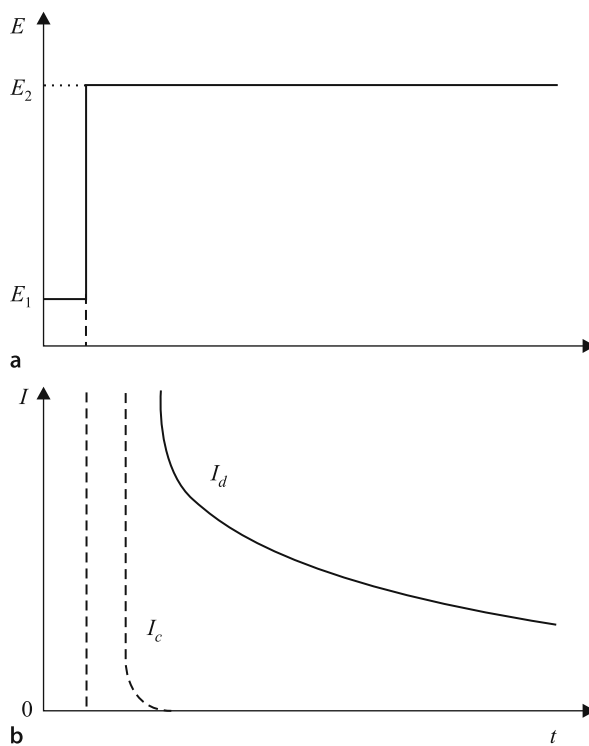

Chronoamperometry — **Figure 1.** Typical waveform of the potential step (a) and the respective chronoamperometric response (b)

i.e., $E \gg E_c^{\ominus'}$, Eq. (3) will be simplified to the Cottrell equation. From the slope of $I(t)$ vs. $t^{-1/2}$ plot – knowing other quantities – D can be determined. The Cottrell equation is valid only for planar electrodes (\rightarrow *electrode geometry*) of “infinite” size, i.e., the edge effect is negligible. For spherical electrodes (\rightarrow *electrode geometry*) or \rightarrow *microelectrodes* – where hemispherical diffusion conditions exist – the solution of the diffusion equation leads to the following equation:

$$I(t) = nFDc^* \left[(\pi Dt)^{-1/2} + r_o^{-1} \right], \quad (4)$$

where r_o is the radius of the spherical electrode or microelectrode disc. Equation (4) turns into the usual Cottrell equation if $r_o \rightarrow \infty$. It can be seen that at long times a steady-state current flows. The smaller the electrode radius, the faster the steady state is achieved.

At short times the currents response deviates from that expected theoretically due to the charging of the \rightarrow *double layer* and possibly inadequate power of the \rightarrow *potentiostat* (see also \rightarrow *chronocoulometry*).

If the heterogeneous \rightarrow *charge transfer* is slow the following expression is valid for an oxidation reaction:

$$I(t) = nFAk_{ox}c_R^* \exp(k_{ox}^2 t/D_R) \operatorname{erfc}(k_{ox} t^{1/2}/D_R^{1/2}). \quad (5)$$

If both the oxidized (O) and reduced (R) forms are present:

$$I(t) = nFA(k_{ox}c_R^* - k_{red}c_O^*) \exp\left[\left(\frac{k_{ox}}{D_R^{1/2}} + \frac{k_{red}}{D_O^{1/2}}\right)^2 t\right] \times \operatorname{erfc}\left[\left(\frac{k_{ox}}{D_R^{1/2}} + \frac{k_{red}}{D_O^{1/2}}\right) t^{1/2}\right]. \quad (6)$$

This equation can be used when the step is made to any potential in the rising portion of the \rightarrow *voltammogram*, where either \rightarrow *charge transfer* control or mixed kinetic-diffusional control prevails. Figure 2 shows the I vs. t responses when the potential is stepped from E_1 to $E_{22} < E_{21} < E_2$, respectively.

(See also current sampled \rightarrow *voltammetry*, and \rightarrow *current sampling*.)

Since at the foot of the voltammetric wave k_{ox} and k_{red} are small, Eqs. (5) and (6) can be linearized. For instance, Eq. (5) is simplified to

$$I(t) = nFAk_{ox}c_R^* \left[1 - \frac{2k_{ox}t^{1/2}}{D_R^{1/2}\pi^{1/2}} \right]. \quad (7)$$

The plotting $I(t)$ vs. $t^{1/2}$ and extrapolating the linear plot to $t = 0$, k_{ox} can be obtained from the intercept.

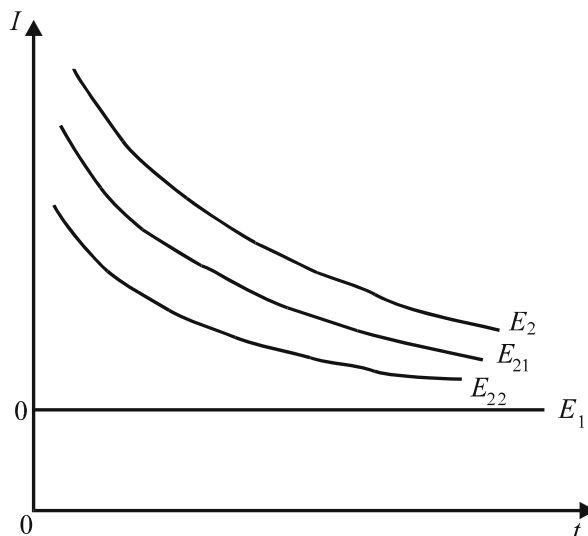

Chronoamperometry — Figure 2. The I vs. t curves when the potential is stepped from E_1 to $E_{22} < E_{21} < E_2$, respectively

In the case of a large \rightarrow *pseudocapacitance*, e.g., an \rightarrow *electroactive polymer* film on the surface, the current-time decay reflect the \rightarrow *diffusion rate* of the \rightarrow *charge carriers* through the surface layer, thus shorter times the decay of the current should conform to the Cottrell equation. At long times, when $(Dt)^{1/2} \geq L$, where L is the film thickness, the concentration within surface film impacts on the film-solution boundary, the chronoamperometric current will be less than that predicted by the Cottrell equation, and a finite diffusion relationship

$$I(t) = \frac{nFAD^{1/2}c^*}{\pi^{1/2}t^{1/2}} \left[1 + 2 \sum_{m=1}^{\infty} (-1)^m \exp\left(-\frac{m^2 L^2}{Dt}\right) \right] \quad (8)$$

becomes appropriate [ii, v].

If the chronoamperometric response of a \rightarrow *polymer-modified electrode* is measured alone – in contact with inert \rightarrow *supporting electrolyte* – Cottrell-type response can be obtained usually for thick films only, because at short times ($t < 0.1$ – 1 ms) the potential is not established while, at longer times ($t > 10$ – 100 ms), the finite diffusion conditions will prevail and I exponentially decreases with time. Another complication that may arise is the dependence of D on the potential in the case of \rightarrow *conducting polymer films* [vi].

Specific current-time curves are obtained in the case of \rightarrow *electrocrystallization* or \rightarrow *electrodeposition*. The characteristic responses expected for different \rightarrow *nucleation* and growth processes, e.g., instantaneous nucle-

ation, one-, two- and three-dimensional layer or layer-by-layer growth can be found in the literature [vii–ix].

Refs.: [i] Bard AJ, Faulkner LR (2001) *Electrochemical methods*. 2nd edn. Wiley, New York, pp 156–180; [ii] Inzelt G (2002) *Kinetics of electrochemical reactions*. In: Scholz F (ed) *Electroanalytical methods*. Springer, Berlin, pp 29–48, 137–148; [iii] Oldham HB, Myland JC (1994) *Fundamentals of electrochemical science*. Academic Press, San Diego; [iv] Rieger PH (1987) *Electrochemistry*. Prentice Hall, Oxford, pp 151–165; [v] Murray RW (1984) *Chemically modified electrodes*. In: Bard AJ (ed) *Electroanalytical chemistry*, vol. 13. Marcel Dekker, New York, pp 191–368; [vi] Inzelt G (1994) *Mechanism of charge transport in polymer-modified electrodes*. In: Bard AJ (ed) *Electroanalytical chemistry*, vol. 18. Marcel Dekker, New York, pp 89–241; [vii] Harrison JA, Thirsk HR (1971) *The fundamentals of metal deposition*. In: Bard AJ (ed) *Electroanalytical chemistry*, vol. 5. Marcel Dekker, New York, pp 67–148; [viii] Vargas T, Varma R (1991) In: Varma R, Selman JR (eds) *Techniques for characterization of electrodes and electrochemical processes*. Wiley, New York, pp 707–760; [ix] Bockris J'OM, Khan SUM (1993) *Surface electrochemistry*. Plenum Press, New York, pp 350–376

GI

Chronocoulometry — Chronocoulometry belongs to the family of step techniques [i–iv]. Whereas in \rightarrow *chronoamperometry* the \rightarrow *current* is measured as a function of time after application of a \rightarrow *potential step* perturbation, in chronocoulometry the amount of the \rightarrow *charge* passed as a function of time is detected. Chronocoulometry gives practically the same information that is provided by chronoamperometry, since it is just based on the integration of the current-time response. Nevertheless, chronocoulometry offers important experimental advantages. First, unlike the current response that quickly decreases, the measured signal usually increases with time, and hence the later parts of the transient can be detected more accurately. Second, a better signal-to-noise ratio can be achieved. Third, contributions of charging/discharging of the electrochemical \rightarrow *double layer* and any \rightarrow *pseudocapacitance* on the surface (charge consumed by the \rightarrow *electrode reaction* of adsorbed species (\rightarrow *adsorption*)) to the overall charge passed as a function of time can be distinguished from those due to the diffusing electroreactants. In the case of the electrochemical oxidation of a species R ($R \rightarrow O^+ + e^-$) after application of the potential step from E_1 (where no current flows) to E_2 (where the current is limited by \rightarrow *diffusion* or more precisely by the rate at which the reactant is supplied to the electrode surface), and the conditions of linear diffusion (flat electrode, unstirred solution) prevail, the current (I) flows at any time (t) will obey the \rightarrow *Cottrell equation*. The time integral of the Cottrell equation – since $Q = \int_0^t I dt$ – gives the cu-

mulative charge (Q) passed in the course of oxidation of R:

$$Q_{\text{diff}}(t) = \int_0^t nFAD_R^{1/2} c_R^* \pi^{-1/2} dt = 2\pi FAD_R^{1/2} c_R^* \pi^{-1/2} t^{1/2}, \quad (1)$$

where $Q_{\text{diff}}(t)$ is the charge consumed until time t , n is the charge number of electrode reaction, F is the \rightarrow *Faraday constant*, A is the surface area, D_R and c_R^* are the diffusion coefficient and the bulk concentration of the reacting species R.

However, at least one additional current component has to be taken into account, because of the charging of \rightarrow *double layer* while stepping the potential from E_1 to E_2 . The equation for the time dependence of the \rightarrow *capacitive current* is given under the entry \rightarrow *charging current*.

After application of a potential step of magnitude $E = E_2 - E_1$, the exponential decay of the current with time depends on the \rightarrow *double-layer capacitance* (C_d) and the solution resistance (R_s) (\rightarrow *resistance*, subentry \rightarrow *solution resistance*), i.e., on the time constant $\tau = R_s C_d$. Consequently, if we assume that C_d is constant and the capacitor is initially uncharged ($Q = 0$ at $t = 0$), for the capacitive charge (Q_c) we obtain

$$Q_c = EC_d (1 - e^{-t/R_s C_d}). \quad (2)$$

In order to obtain a straight line in the Q vs. $t^{1/2}$ plot for a relatively long period of time – which is the precondition of straightforward data evolution – the decay of the current belonging to the double-layer charging should be very fast. It follows that the application of a \rightarrow *working electrode* of small A in order to decrease C_d and the use supporting electrolyte to lower R_s is of importance to decrease this effect and to maintain potential control. The typical waveform of a potential step experiment and the respective chronocoulometric curve are shown schematically in Fig. 1. The Q_c vs. t curve, which is also displayed, can be determined by repeating the experiment in the absence of R, i.e., in pure supporting electrolyte.

If R is adsorbed at the electrode surface at E_1 , the adsorbed amount will also be oxidized at E_2 . This process is usually very quick compared to the slow accumulation of R by diffusion. The total charge can be given as follows:

$$Q(t) = Q_{\text{diff}}(t) + Q_c(t) + Q_{\text{ads}}(t). \quad (3)$$

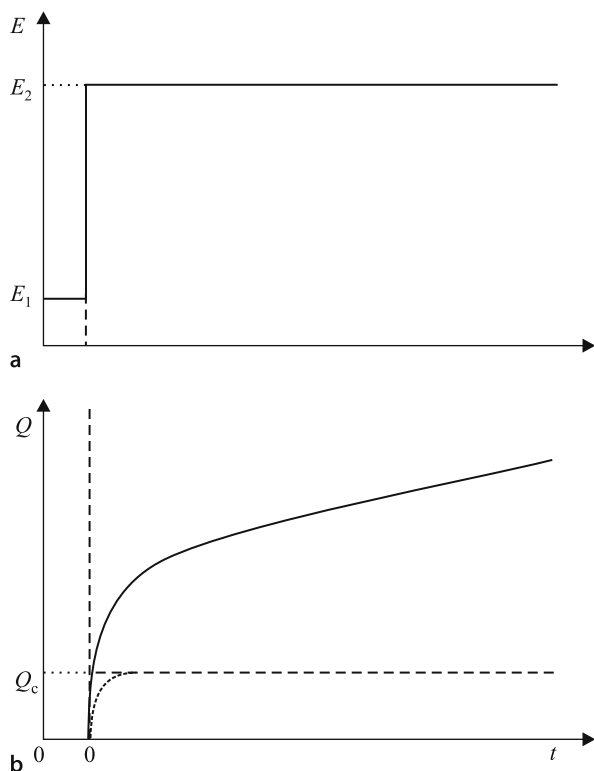

Chronocoulometry — Figure 1. Waveform of a potential step experiment (a) and the respective chronocoulometric response (b). Dashed curves in b displayed for the illustration of the capacitive charge effect

From Q_{ads} the adsorbed amount of R (Γ_R) can be estimated, since $Q_{ads} = nF\Gamma_R$.

According to Eq. (1), the plot of Q_{diff} vs. $t^{1/2}$ should be linear and the slope is proportional to the concentration of the reactant, as well as to n , A , and $D^{1/2}$. It is shown in Fig. 2.

From the slope, e.g., D can be calculated provided that all other quantities are known, while the intercept gives $Q_c + Q_{ads}$. At very short times Q vs. $t^{1/2}$ curves are not linear, since neither the charging process nor the oxidation of the adsorbed amount of reactant is instantaneous, albeit under well-designed experimental conditions (see above) this period is less than 1 ms. This effect is indicated as dotted extensions of lines 1 and 2 in Fig. 2.

Chronocoulometric responses may be governed wholly or partially by the \rightarrow charge transfer kinetics. In some cases, the diffusion-limited situation cannot be reached, e.g., due to the insufficient power of the potentiostat and the inherent properties of the system, especially at the beginning of the potential step. If the heterogeneous \rightarrow rate constants, k_{ox} , or k_{red} are small the following expression can be derived, e.g., for the

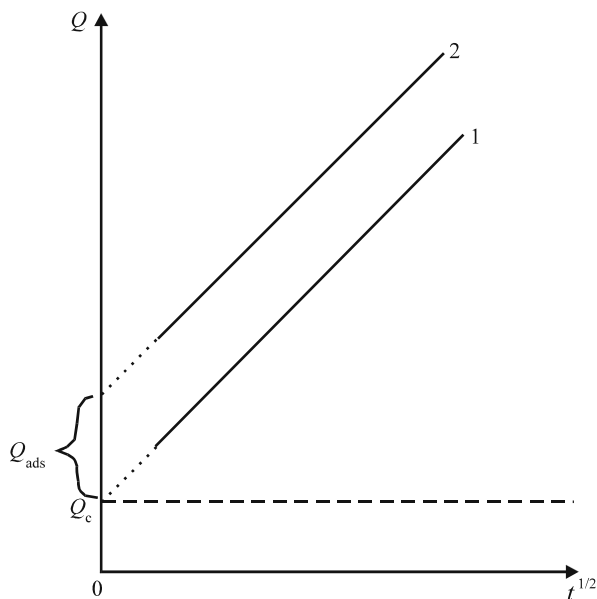

Chronocoulometry — Figure 2. Chronocoulometric charge vs. (time) $^{1/2}$ plot in the absence (1) and in the presence (2) of adsorption. The dashed, horizontal line represents the charge response in the absence of reactant

oxidation:

$$Q(t) = \frac{nFAD_R c_R^*}{k_{ox}} \left[\exp\left(\frac{k_{ox}^2}{D_R^{1/2}} t\right) \times \operatorname{erfc}\left(\frac{k_{ox}}{D_R^{1/2}} t^{1/2}\right) + \frac{2k_{ox} t^{1/2}}{D_R^{1/2} \pi^{1/2}} - 1 \right]. \quad (4)$$

At high values of $\frac{k_{ox}}{D_R^{1/2}}$, i.e., when k_{ox} is high or D_R is small, e.g., in polymer solution of high viscosity, Eq. (1) is approached.

If the potential amplitude of the step is less than $E_2 - E_1$, i.e., the step is made to any potential in the rising portion of the \rightarrow voltammogram, either \rightarrow charge transfer control or mixed kinetic-diffusional control prevails [$c_R(x=0)$ is not zero but smaller than c_R^*]. For the description of these curves Eq. (2) can be applied, and k_{ox} can be calculated.

In the case of \rightarrow polymer-modified electrodes (see also \rightarrow chronoamperometry) due to the finite diffusion (\rightarrow diffusion, subentry \rightarrow finite diffusion) conditions the chronocoulometric curve can be given as follows:

$$\frac{Q}{Q_T} = 1 - \frac{8}{\pi^2} \sum_{m=1}^{\infty} \left(\frac{1}{2m-1} \right)^2 \exp\left[-(2m-1)^2 \pi^2 \frac{Dt}{L^2}\right], \quad (5)$$

where Q_T is the total charge that can be consumed by the electroactive surface film ($Q_T = Q_{\text{ads}}$) and L is the film thickness. For 2% accuracy, it is enough to consider the first member of the summation ($m = 1$), hence

$$\frac{Q}{Q_T} = 1 - \frac{8}{\pi^2} \exp\left(-\pi^2 \frac{Dt}{L^2}\right). \quad (6)$$

It follows that, in the presence of a thick ($L > 100$ nm, $\Gamma > 10^{-8}$ mol cm $^{-2}$), electrochemically active surface

layer reliable measurement can be made in a time window from ms to some seconds [ii, v].

Double-step chronocoulometry is a powerful tool in identifying adsorption phenomena, in obtaining information on the kinetics of coupled homogeneous reactions and for the determination of the capacitive contribution. The double potential step is executed in such a way that after the first step from E_1 to E_2 , a next step is applied, i.e., the reversal of the potential to its initial value E_1 from E_2 (see Fig. 3).

It means that the product O^+ is reduced again during the second step from E_2 to E_1 . If the magnitude of the reversal step is also large enough to ensure diffusion control, the chronocoulometric response for $t > \tau$ – where τ is the duration of the first step – is given by the following equation:

$$Q_{\text{diff}}(t > \tau) = 2nFAD_R^{1/2} c_R^* \pi^{-1/2} \left[t^{1/2} - (t - \tau)^{1/2} \right]. \quad (7)$$

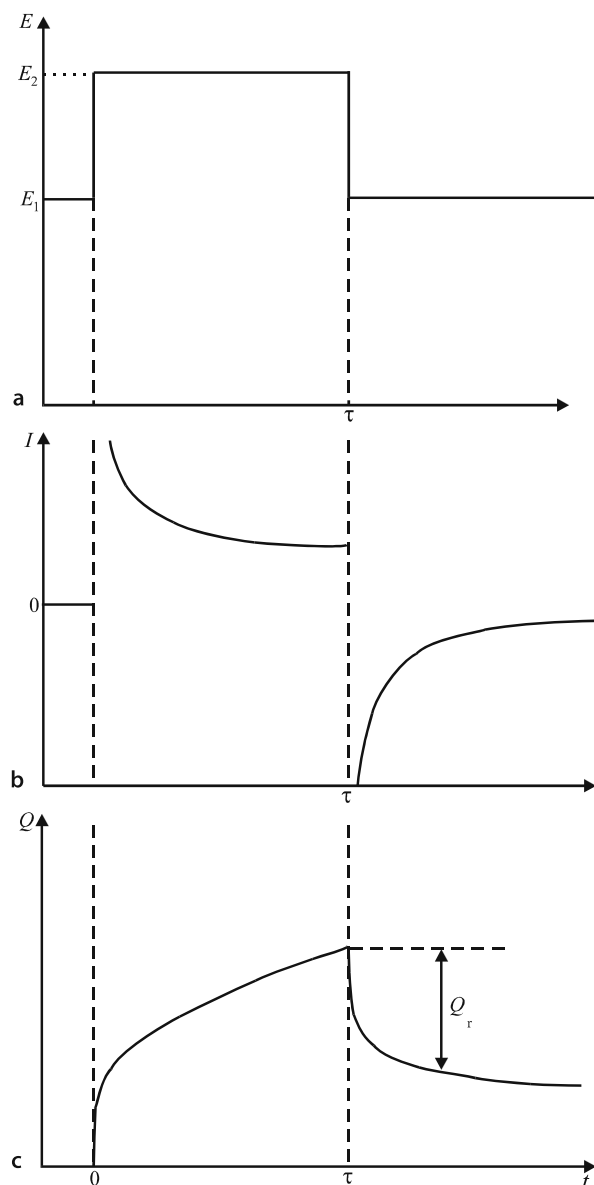

Chronocoulometry — Figure 3. The waveform (a), the chronoamperometric (b), and chronocoulometric (c) responses in the case of double potential steps

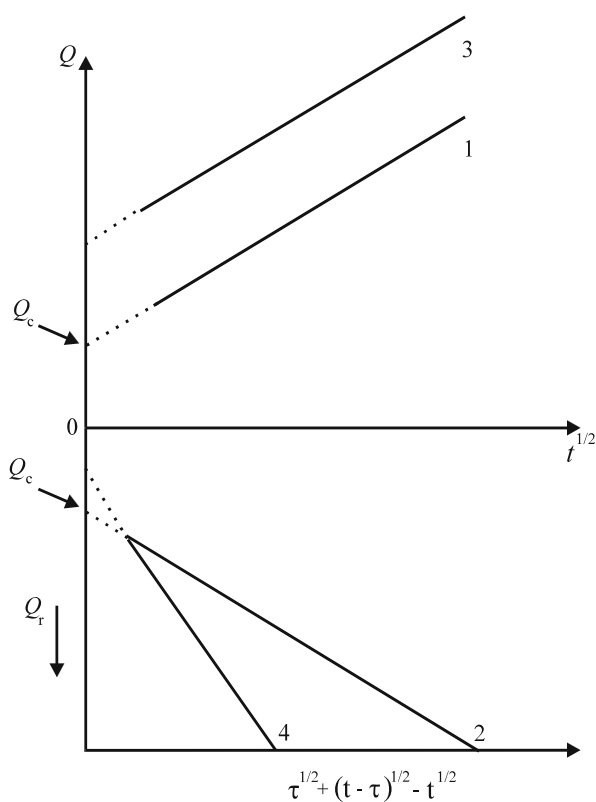

Chronocoulometry — Figure 4. Chronocoulometric plots for double step experiments. Lines 1 and 2 correspond to the case when no adsorption of the reactant or product occurs. Lines 3 and 4 depict the linear responses when the reactant is adsorbed

It is important to note that there is no capacitive contribution because the net potential change is zero.

The quantity of charge consumed in the reversal step is the difference $Q(\tau) - Q(t > \tau)$ since the second step actually withdraws the charge injected during the first step:

$$Q_{\text{diff}}(t > \tau) = 2nFAD_R^{1/2}c_R^*\pi^{-1/2} \times \left[\tau^{1/2} + (t - \tau)^{1/2} - t^{1/2} \right]. \quad (8)$$

By plotting $Q(t < \tau)$ vs. $t^{1/2}$ and $Q(t > \tau)$ vs. $\left[\tau^{1/2} + (t - \tau)^{1/2} - t^{1/2} \right]$ two straight lines should be obtained. In the absence of adsorption the intercept is Q_c and the two intercepts are equal (see Fig. 4).

Refs.: [i] Bard AJ, Faulkner LR (2001) *Electrochemical methods*, 2nd edn. Wiley, New York, pp 210–216; [ii] Inzelt G (2002) *Chronocoulometry*. In: Scholz F (ed) *Electroanalytical methods*. Springer, Berlin, pp 137–148; [iii] Galus Z (1994) *Fundamentals of electrochemical analysis*, 2nd edn. Ellis Horwood, New York, Polish Scientific Publisher PWN, Warsaw; [iv] Brett CMA, Oliveira Brett AM (1993) *Electrochemistry*. Oxford University Press, Oxford, pp 206–208; [v] Chambers JQ (1980) *J Electroanal Chem* 130:381

Chronodectogram — A deflection signal where the deviation angle (θ) of a probe laser beam is plotted as a function of time. It is also called chronodectometric profile or PBD transient and is usually characterized by the presence of the \rightarrow PBD maximum (or minimum) during the time evolution of the deflection signal [i]. See also \rightarrow chronodectometry.

Ref.: [i] Barbero CA (2005) *Phys Chem Chem Phys* 7:1885; [ii] Garay F, Barbero CA (2006) *Anal Chem* 78:6740

Chronodectometry (CD) — A \rightarrow probe beam deflection method in which a \rightarrow potential pulse is applied, usually from a potential where there is no reaction, to one where the reaction evolves completely to the formation of products. The time evolution of the deflection signal is sampled and plotted as a function of time, which is named \rightarrow chronodectogram [i].

Ref.: [i] Barbero CA (2005) *Phys Chem Chem Phys* 7:1885; [ii] Garay F, Barbero CA (2006) *Anal Chem* 78:6740

Chronopotentiometry — is a controlled-current technique (\rightarrow dynamic technique) in which the \rightarrow potential variation with time is measured following a current step (also cyclic, or current reversals, or linearly increasing currents are used). For a \rightarrow nernstian electrode process,

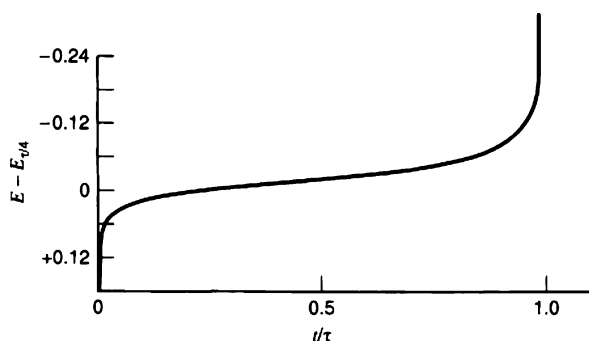

Chronopotentiometry — Figure

the theoretical chronopotentiogram following a current step is shown below [i].

The potential at a planar electrode varies only to a small extent until the end of the transition time τ , which corresponds to the total consumption of the electroactive species in the neighborhood of the electrode, described by the \rightarrow Sand equation. If the capacitive current contribution, larger at the beginning and at the end of the chronopotentiogram, is neglected, one gets for a reversible system: $E = E_{\tau/4} + \frac{RT}{nF} \ln \frac{\tau^{1/2} - t^{1/2}}{t^{1/2}}$, where

$E_{\tau/4} = E_c^{\ominus'} + \frac{RT}{nF} \ln \left(\frac{D_R}{D_O} \right)^{1/2}$, the so-called quarter-wave potential, is identifiable with $E_{1/2}^r$ in a conventional voltammogram. For an irreversible system, there is: $E = E_c^{\ominus'} + \frac{RT}{\alpha n' F} \ln \left[\frac{2k_0}{(\pi D_O)^{1/2}} (\tau^{1/2} - t^{1/2}) \right]$. $E_c^{\ominus'}$ is the \rightarrow formal potential of the system, D_R and D_O are the \rightarrow diffusion coefficients of the reduced and oxidized species, n is the number of transferred electrons, F is the \rightarrow Faraday constant, α is the \rightarrow symmetry coefficient, R is the \rightarrow gas constant, and T the absolute temperature. The \rightarrow transition time is proportional to the concentration of the electroactive species. See also \rightarrow cyclic chronopotentiometry.

Refs.: [i] Bard AJ, Faulkner LR (2001) *Electrochemical methods*, 2nd edn. Wiley, New York, pp 305–330; [ii] Brett CMA, Brett AMO (1998) *Electrochemistry*. Oxford University Press, Oxford, pp 208–212

MHer

Chutaux cell — This was a chromic acid (carbon electrode)–zinc \rightarrow battery constructed in such a way that the electrolyte solutions could flow along the electrodes to reduce concentration polarization.

See also \rightarrow chromic acid battery, \rightarrow Daniell cell, \rightarrow zinc, \rightarrow Zn^{2+}/Zn electrodes, \rightarrow $Zn^{2+}/Zn(Hg)$ electrodes, \rightarrow zinc–air batteries (cell), and \rightarrow Leclanché cell.

Ref.: [i] Hauck WP (1883) *Die Galvanischen Batterien, Accumulatoren und Thermosäulen*, 2nd edn. Hartleben's Verlag, Wien

FS

CIE — Acronym for “Commission Internationale de l’Eclairage”. By general consent, in all countries the specification of standard (i.e., ideal) observers for use in colorimetry and photometry is the province of CIE.

Ref.: [i] Wyszecki G, Stiles WS (2000) *Color science – concepts and methods, quantitative data and formulae*. Wiley, New York

IH

CIE chromaticity coordinates — Coordinates used to quantitatively represent colors. The → CIE colorimetric system comprises the essential standards and procedures of measurement that are necessary for science and technology, and thus also including applications in electrochemistry, i.e., for quantification of → *electrochromism*. With the trichromatic generalization states that cover a wide range of conditions of observation, many color stimuli can be matched in color completely by additive mixtures of three fixed primary stimuli whose radiant power have been suitably adjusted. For this reason, it is convenient to represent color stimuli by vectors in a three-dimensional space, where stimuli can be represented as a linear combination of primary stimuli, i.e., a linear combination of vectors of unit length \hat{R} , \hat{G} , and \hat{B} : $\vec{Q} = R\hat{R} + G\hat{G} + B\hat{B}$. Tristimulus vectors Q then intersect the plane $R + G + B = 1$ in a point Q . The position of point Q in the plane can be used as color stimuli representation. Convenient coordinate axes in the unit plane are the lines of intersection of the unit plane with the three planes defined by pairs of the vectors R , G , and B . The lines (r , g , b) define an equilateral triangle, so that a bidimensional representation of the stimuli is possible in the triangle. The chromaticity coordinates are related to the tristimulus values R , G , and B through the expressions $r = \frac{R}{R+G+B}$, $g = \frac{G}{R+G+B}$, and $b = \frac{B}{R+G+B}$, so that $r + g + b = 1$. A more convenient version, however, is a triangle where the r and g coordinate axes are perpendicular to each other, which is used when plotting chromaticity points. Each point in this representation corresponds to coordinates r and g , which are the chromaticity coordinates. The third coordinate, b , can then be determined using the equation $r + g + b = 1$.

Ref.: [i] Wyszecki G, Stiles WS (2000) *Color science – concepts and methods, quantitative data and formulae*. Wiley, New York

IH

Circuit — There are two major meanings of the word circuit in electrochemistry. The first one is related to the actual electronic assembly in the electrochemical instruments and particularly to the ways the → *operational amplifiers* serve in these electrical networks. Several circuits with particular functions have been developed for elec-

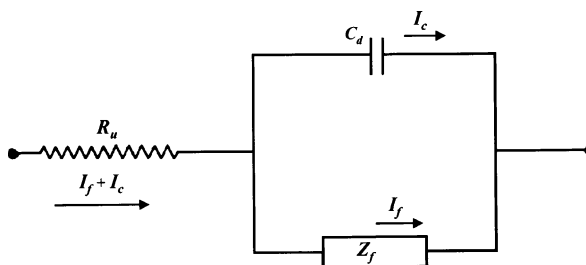

Circuit — Figure

trochemistry. They include: voltage follower, current follower, scaler, inverter, adder, current integrator and differentiator, voltage controller, current controller, and IR drop compensation circuit [i]. The electrochemical cell is in fact a circuit and can be a part of a circuit. The term → *open-circuit potential* is related to the potential of a cell that is not loaded with current.

The second meaning of the word circuit is related to → *electrochemical impedance spectroscopy*. A key point in this spectroscopy is the fact that any → *electrochemical cell* can be represented by an **equivalent electrical circuit** that consists of electronic (resistances, capacitances, and inductances) and mathematical components. The equivalent circuit is a model that more or less correctly reflects the reality of the cell examined. At minimum, the equivalent circuit should contain: a → *capacitor* of → *capacity* C_d representing the → *double layer*, the → *impedance* of the faradaic process Z_f , and the uncompensated → *resistance* R_u (see → IR_u potential drop). The electronic components in the equivalent circuit can be arranged in series (series circuit) and parallel (parallel circuit). An equivalent circuit representing an electrochemical → *half-cell* or an → *electrode* and an uncomplicated electrode process (→ *Randles circuit*) is shown below. I_c and I_f in the figure are the → *capacitive current* and the → *faradaic current*, respectively.

Refs.: [i] Bard AJ, Faulkner LR (2001) *Electrochemical instrumentation*. In: Bard AJ, Faulkner LR (eds) *Electrochemical methods*, 2nd edn. Wiley, New York; [ii] Brett CMA, Oliveira Brett AM (1996) *Electrochemistry*. Oxford University Press, Oxford; [iii] Retter U, Lohse H (2002) *Electrochemical impedance spectroscopy*. In Scholz F (ed) *Electrochemical methods*. Springer, Berlin

ZS

Equivalent circuit → *circuit*

Parallel circuit → *circuit*

Poggendorff compensation circuit (principle, method) — The correct measurement of the → *potential* of a → *cell* or a → *half-cell* can be performed if during the measurement there is practically no current flowing

through the \rightarrow *electrodes*; otherwise the \rightarrow *activities* of the redox species are affected and the measured potential is erroneous. Recently this requirement has been accomplished by using a high input \rightarrow *impedance* instrument. In early years of \rightarrow *potentiometry* such instruments were not available and, instead, one of two Poggendorff compensation methods was applied. The first one is based on a circuit in which the unknown electromotive force is balanced by the product of a constant current and the resistance of a calibrated resistor. In the second method the ratio of an examined and a known potential are set equal to the ratio of two known constant resistances. See also the history and the details of the measurement in the main entry \rightarrow *Poggendorff compensation circuit*.

Refs.: [i] Crompton TR (2000) *Battery reference book*, 3rd ed. Butterworth-Heinemann, Oxford; [ii] Scholz F (ed) (2002) *Electrochemical methods*. Springer, Berlin

Series circuit \rightarrow *circuit*

Clark, Leland Charles



(Dec. 04, 1918, Rochester, N.Y., USA – 25 Sep. 2005, Cincinnati, OH, USA) Clark developed a passion for science as a child. One of the few students ever to make a perfect score of 100 on the New York State Regents science exam, he earned a bachelor's degree in chemistry from Antioch College in 1941. He subsequently graduated from the University of Rochester School of Medicine and Dentistry with a Ph.D. in biochemistry and physiology in 1944. After graduation, he returned to the Antioch College campus to form a biochemistry department at the newly opened Fels Research Institute. In 1955 he moved to Cincinnati as a senior research associate of pediatrics and surgery. From 1958 to 1968 he was a professor in the department of surgery at the University of Alabama College of Medicine. In 1968, he returned to Cincinnati and served as Head of the Division of Neurophysiology at the Children's Hospital Med-

ical Center until 1991. He is best known for the invention of the voltammetric membrane oxygen electrode to measure levels of dissolved oxygen in blood (\rightarrow *Clark oxygen sensor*) [i]. Prior to that, the only way to measure oxygen in blood was to draw a sample, take it to the lab, and analyze it. Clark's electrode allowed oxygen to be monitored actually during surgery, an invention that has saved millions of lives over the past half century. Today, the oxygen electrode also provides the basis of a series of non-medical technologies, ranging from the detection of oxygen in oceans and rivers to the successful manufacture of beer and wine. After becoming a Professor of Surgery, Clark continued his research to increase the number of analytes that could be measured in the human body. In a presentation at the New York Academy of Sciences in 1962 he showed how this could be done, by immobilizing enzymes on top of his basic oxygen electrode design using a dialysis membrane [ii]. Using this approach, various substrates (such as glucose) could freely interact with the enzymes to create peroxide, and then the peroxide could be detected by the electrode. In this way, the first generation of \rightarrow *biosensors* was created.

Refs.: [i] Clark LC (1959) US Patent 2,913,386; [ii] Clark LC, Lyons C (1962) *Ann NY Acad Sci* 102:29

ZS

SF

Clark and Muirhead cell — This was a variation of the \rightarrow *Leclanché cell*. See \rightarrow *Daniell cell*, \rightarrow *zinc*, \rightarrow *Zn²⁺/Zn electrodes*, \rightarrow *Zn²⁺/Zn(Hg) electrodes*, \rightarrow *zinc-air batteries (cell)*, and \rightarrow *Leclanché cell*.

Ref.: [i] Hauck WP (1883) *Die Galvanischen Batterien, Accumulatoren und Thermosäulen*, 2nd edn. Hartleben's Verlag, Wien

FS

Clark cell — Electrochemical \rightarrow *standard cell* showing a particularly stable and reproducible cell voltage. A zinc and a mercury electrode (half-cell) are combined according to

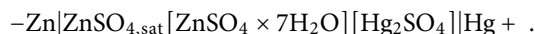

The cell reaction upon discharge is

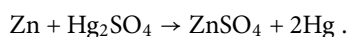

The cell voltage is 1.434 V at $T = 15^\circ\text{C}$.

Ref.: [i] Handel S (1971) *A dictionary of electronics*. Penguin Books, London

RH

Clark electrode — Electrochemical device measuring the concentration of oxygen liberated in an enzymatic

sensor reaction occurring in the region directly in front of the Clark oxygen sensor. For the mode of operation see → *Clark oxygen sensor*. See also → *Clark*.

Ref.: [i] Wang J (1994) *Analytical electrochemistry*. VCH, New York

RH

Clark oxygen sensor — (see also → *Clark electrode*) Electrochemical → *sensor* used for the amperometric measurement (→ *amperometry*) of the concentration of → *dioxygen*. The two-electrode cell contains a large surface area silver disc acting as the → *anode* and a small platinum or gold disk used as dioxygen reducing → *cathode* (see figure) [i, ii]. A porous → *membrane* not permeable for the buffered aqueous electrolyte solution inside the sensor prevents loss of the internal solution while allowing diffusion of dioxygen from the exterior into the sensor.

In the buffered aqueous electrolyte solution saturated with KCl the cathodic process

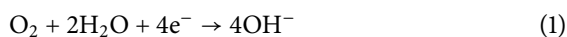

is balanced by the anodic dissolution of silver. The electrical voltage applied to the electrodes is adjusted to a fixed voltage sufficient to operate the cathode in the diffusion limited → *current* range; the large area of the silver electrode and the composition of the → *buffer* solution establishes a potential of the silver electrode practically constant and not depending on the actual current. The current solely depends on the concentration of dioxygen present at the cathode; this in turn depends on the concentration of dioxygen in front of the exterior surface of the semipermeable membrane. Thus the current depends on the dioxygen concentration outside. Alternative designs have been described [iii, iv].

Refs.: [i] Clark LC (1956) *Trans Am Soc Artif Intern Organs* 2:41;

[ii] Wang J (1994) *Analytical electrochemistry*. VCH, New York;

[iii] Mackereth FJH (1964) *J Sci Instrum* 41:38; [iv] Nei L (1995) *Electroanalysis* 7:471

RH

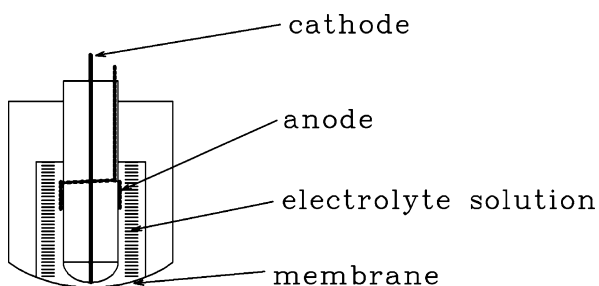

Clark oxygen sensor — Figure

Classen, Alexander — (Apr. 13, 1843, Aachen, Germany – Jan. 28, 1934, Aachen, Germany) Ph.D. 1864 in Berlin, since 1878 Professor at the “Technische Hochschule Aachen”. Classen is most well-known for his contributions to the development of → *electrogravimetry*. He wrote a very influential book on that technique which was published in numerous editions [i].

Ref.: [i] Classen A (1882) *Quantitative Analyse auf Electrolytischem Wege*. Mayer, Aachen; (1908) 5th edn. Springer, Berlin; Engl Transl: Classen A (1913) *Quantitative analysis by electrolysis*. Wiley, New York

FS

Clausius, Rudolf Julius Emmanuel

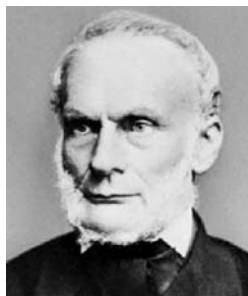

(Jan. 1, 1822, Köslin, Germany, now Koszalin, Poland – Aug. 25, 1888, Bonn, Germany) Clausius studied mathematics and physics at the University of Berlin 1840–1844, dissertation on reflection of light in the sky at Halle University 1847, 1850 first paper on mechanical theory of heat, 1850 professor at the Royal Artillery and Engineering School in Berlin, 1855 Chair of Mathematical Physics at the Polytechnikum in Zurich and professor at the University of Zurich, 1867 professor at the University of Würzburg, 1869 chair at the University of Bonn, work on first and second laws of thermodynamics.

See also → *Debye–Clausius–Mossotti equation*, and → *Clausius–Mossotti equation*.

Ref.: [i] Crystal D (ed) (1998) *The Cambridge biographical encyclopedia*. Cambridge University Press, Cambridge

RH

Clausius–Mossotti equation — Named after → *Clausius* and Ottaviano Fabrizio Mossotti (1791–1863). It relates the electron → *polarizability* α of an individual molecule to the optical → *dielectric constant* (relative → *permittivity*) ϵ_r of the bulk material.

$$\frac{\epsilon_r - 1}{\epsilon_r + 2} = \frac{N\alpha}{3\epsilon_0}$$

Here N is the number of molecules per unit volume and ϵ_0 is the vacuum permittivity (8.854×10^{-12} F/m).

The same formula applies if the electron polarizability is replaced by the total polarizability, and the optical dielectric constant is replaced by the static dielectric constant, provided attention is then restricted to nonpolar materials.

Refs.: [i] Mossotti OF (1850) *Memorie di matematica e di fisica della società italiana della scienza residente in modena* 24; 49; [ii] Clausius R (1879) *Die Mechanische Wärmetheorie*, vol. 2. Vieweg & Sohn, Braunschweig, p 62

SF

Closed-circuit voltage — The closed-circuit voltage, or CCV, refers to the voltage quantity as measured across the terminals of an → *electrochemical cell* or a → *battery* under a specific discharge load and time interval in a closed circuit. Particularly, this CCV is measured in case of a power supply working on load, e.g., a discharging battery. As a battery has an internal → *resistance*, the CCV is lower than → *open-circuit voltage*, OCV, and CCV decreases with increasing current.

Refs.: [i] Linden D, Reddy TB (eds) (2001) *Handbook of batteries*, 3rd edn. McGraw-Hill; [ii] Berndt D (ed) (2003) *Maintenance-free batteries: lead-acid, nickel/cadmium, nickel/hydrate – A handbook of battery technology (Electronic & electrical engineering research studies power sources technology)*. Research Studies Press

MHer

Cloud point → *critical micelle concentration*

CMC → *critical micelle concentration*

Coated-wire electrode — A polymer film containing an ion-responsive material and a binder, e.g., poly(vinyl)chloride, is coated onto a conductor (e.g., a metal wire or graphite). They show useful response to solution concentrations of measured species in the range $10^{-5} < c < 0.1 \text{ mol dm}^{-3}$. The processes at the metal|polymer interface are still not understood.

→ *Donnan potential*, → *ion-selective electrodes*.

Refs.: [i] James H, Carmack G, Freiser H (1972) *Anal Chem* 44:856; [ii] Wang J (1994) *Analytical electrochemistry*. VCH; [iii] Martin CR, Freiser H (1980) *J Chem Educ* 57:152

RH

Codeposition (electrochemical) — Simultaneous deposition of metals, or of a compound as a result of at least two simultaneously proceeding reactions. Thus the codeposition of copper and selenium as Cu₂Se results when a solution containing Se(IV) and Cu(II) is reduced at a suitable potential. Codepositions are used for the electrochemical synthesis of → *semiconductors*, and of

alloys (→ *alloy deposition*), and they are used in → *electroanalysis*, especially in → *cathodic stripping voltammetry*, and in → *anodic stripping voltammetry* (see also → *thin mercury film electrode*).

FS

Cold fusion — A nuclear fusion reaction that takes place at ambient temperature and regular pressure, while the classical plasma fusion reactions require temperatures of millions of degrees. In electrochemistry the first report on a pretended cold fusion was given on March 23, 1989. On that day Martin Fleischmann and Stanley Pons of the University of Utah spoke at a press conference and claimed they did a simple electrolysis of heavy water with a palladium → *cathode* and obtained excess heat as well as radiation that could only be explained by a nuclear process (fusion of deuterium into helium or tritium). Palladium was used, since this metal has an ability of accumulating a large amount of hydrogen in it [i]. That announcement triggered a wave of experiments and very emotional discussions. Both, chemists and physicists found the evidence for cold fusion to be unconvincing and rejected the results published by Fleischman and Pons and their followers [ii, iii].

Refs.: [i] Fleischmann M, Pons S (1990) *J Electroanal Chem* 287:293; [ii] Nagel DJ (1998) *Radiat Phys Chem* 51:653; [iii] (2004) DOE Warns to Cold Fusion. *Physics Today*, April:1

ZS

Cole-Cole diagram → *dielectric relaxation*

Colloids — Systems of particles with a size ranging from 1 nm to a few micrometers are called colloids. Colloids are categorized into 1) molecular colloids or polymer colloids for dispersion of polymers such as proteins and starch in a solvent, 2) association colloids or → *micelle* colloids formed by higher concentrations of surfactant than a → *critical micelle concentration*, 3) dispersion colloids of small particles. Their common features are Brownian motion, large optical scattering, dependence of color or turbidity on particle size, large variation of physical properties with surface charge, and surface tension (→ *interfacial tension*) [i]. Colloidal suspensions without salt exhibit iridescence owing to formation of colloidal crystals [ii]. Micelles (see also → *vesicles*) have often been used for dispersion of sparingly soluble species, → *nanoparticles*, and latex particles. Metal nanoparticles in electrochemical work have been used in the form of colloidal suspensions. → *liposomes* [iii] and latex particles [iv], being visualized by an optical microscope, can work as giant redox particles. The forces

acting between the particles of colloids are described by the \rightarrow DLVO theory (see also \rightarrow Hamaker constant). For the effect of salts on stability see also \rightarrow Hofmeister series. For the interaction of ultrasound with colloids see \rightarrow electroacoustics, for the interaction of an electric field with colloids see \rightarrow electroconvection, \rightarrow electrokinetic effects, \rightarrow electrophoresis, and \rightarrow electrorheological fluid. For preparation of colloids see \rightarrow peptization, for electrochemistry of colloids see \rightarrow suspensions, electrochemistry of \sim .

The history of colloid science is associated with \rightarrow Donnan, \rightarrow Freundlich, \rightarrow Frumkin, \rightarrow Graham, \rightarrow Liesegang, \rightarrow Ostwald, Wo., \rightarrow Smoluchowski, \rightarrow Svedberg, \rightarrow Tiselius, and \rightarrow Zsigmondy.

Refs.: [i] Mackay RA, Texter J (1992) *Electrochemistry in colloids and dispersions*. Wiley, New York; [ii] Arora AK, Tara BVR (1996) *Ordering and phase transitions in charged colloids*. VCH, New York; [iii] Zhan W, Bard AJ (2006) *Anal Chem* 78:726; [iv] Xu C, Aoki K (2004) *Langmuir* 20:10194

KA

Colloid vibration potential \rightarrow electroacoustics

Column electrode — Electrode used for flow electrolysis that involves letting the solution to be electrolyzed flow continuously through a \rightarrow porous electrode of large surface area. The porous electrode is prepared by packing conductive material (e.g., \rightarrow glassy carbon grains, metal shot, or \rightarrow carbon fiber) in a porous column. A typical electrolysis system with a column electrode is shown in the Figure. Continuous-flow column electrolytic methods can result in high efficiencies and rapid conversions. For the electrode reaction, $\text{Ox} + ne^- \rightarrow \text{R}$, the cur-

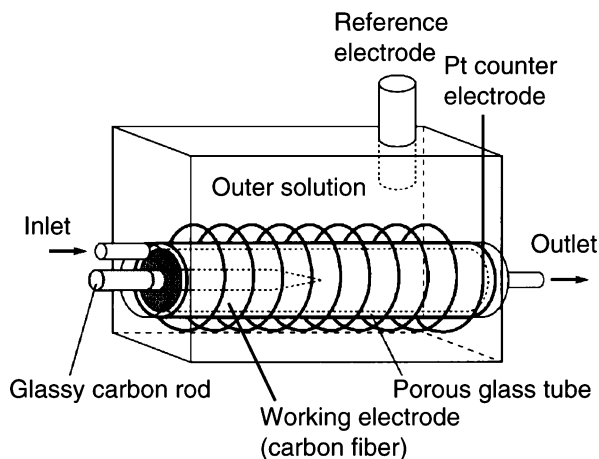

Column electrode — **Figure.** A typical electrolysis system with a column electrode

rent at a constant volumetric flow rate v is given by $I = nFv(c_{\text{Ox}}(\text{out}) - c_{\text{Ox}}(\text{in}))$, where $c_{\text{Ox}}(\text{out})$ and $c_{\text{Ox}}(\text{in})$ are the concentrations of Ox at the outlet and inlet, respectively. For 100% conversion efficiency, the \rightarrow Nernst equation is satisfied for the outlet concentrations of Ox and R. By on-line connection of the \rightarrow flow cell with a spectroscopic instrument, the electrolysis product(s) can be analyzed spectrophotometrically. Column electrolytic methods are also used in industrial situations (e.g., removal of metals such as copper or organic pollutants in wastewater treatment).

Refs.: [i] Fujinaga T, Kihara S (1977) *CRC Crit Rev Anal Chem* 6:223; [ii] Strohl AN, Curran DJ (1979) *Anal Chem* 51:353

TO

Combination electrode — is a combination of an \rightarrow ion-selective electrode and an external \rightarrow reference electrode in a single unit, avoiding a separate holder for the external reference electrode, i.e., it usually contains one ion-selective \rightarrow membrane and two reference electrodes, one on either side of the membrane. Most commercial \rightarrow glass electrodes and \rightarrow ion-selective electrodes are combination electrodes.

Ref.: [i] Buck RP, Lindner E (1994) *Pure Appl Chem* 66:2527

HK

Complex — A molecular entity formed by the reversible association of two or more chemical species (molecules, atoms, or ions). Very different kinds of bonds can be involved. The term has been used with a variety of shades of meaning in different contexts. Therefore, whenever appropriate, the use of more explicit terms such as \rightarrow coordination entity or \rightarrow adduct are recommended [i]. See also \rightarrow chelate.

Ref.: [i] Muller P (1994) *Pure Appl Chem* 66:1077

FG

Complex capacitance \rightarrow electrochemical impedance spectroscopy

Complex electrode \rightarrow electrode

Complex-formation constant \rightarrow stability constant

Complex-formation titration — A method based on the \rightarrow titration between a metal ion and electron-pair donor species to form coordination compounds named \rightarrow complexes. The donor species is usually called complexing agent or \rightarrow ligand and it can have one or several pairs of unshared electrons available to bond a metal species [i].

Ref.: [i] Harris D (2002) *Quantitative chemical analysis*. WH Freeman, New York

C

Complex nonlinear least-squares regression (CNLS) —

This statistical method is used for the estimation of parameters of \rightarrow electrode reaction by fitting a theoretical relationship to experimentally obtained data. This is achieved by minimizing the sum of squared deviations of the observed values for the dependent variable from those predicted by the model. Nonlinear least-square estimations can not be performed algebraically and numerical search procedures are used [i]. The Marquardt algorithm is commonly applied in the calculations performed by commercially available computer programs [ii].

Refs.: [i] Taur Y, McCulloch CE (1999) *J Statistics Educ* 7; [ii] Press WH, Teukolsky SA, Vetterling WT, Flannery BP (1992) *Numerical recipes in C: the art of scientific computing*. Cambridge University Press, New York

FG

Complex plane plot — The complex number $Z = Z' + iZ''$, where $i = \sqrt{-1}$, can be represented by a point in the Cartesian plane whose abscissa is the real part of Z and ordinate the imaginary part of Z . In this representation the abscissa is called the real axis (or the axis of reals) and the ordinate the imaginary axis (the axis of imaginaries), the plane $OZ'Z''$ itself being referred to as the complex plane [i]. The representing point of a complex number Z is referred to as the point Z .

If the real and imaginary parts of the complex quantity (number) Z are a function of a certain scalar argument, such as the \rightarrow angular velocity ω , as ω varies, the complex number Z traces a curve which is called

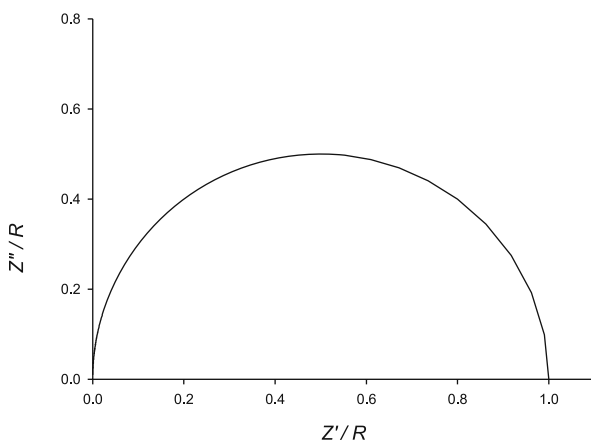

Complex plane plot — Figure. Theoretical \rightarrow impedance of a parallel connection of a resistance and a capacitance

the hodograph of Z . For instance, in the case of a parallel connection of a \rightarrow resistance and a \rightarrow capacitance, the real and imaginary parts of the \rightarrow impedance are [ii]:

$$Z' = \frac{R}{1+(\omega RC)^2} \text{ and } Z'' = -\frac{\omega R^2 C}{1+(\omega RC)^2}. \text{ The hodograph of } Z \text{ is a semicircle of the radius } \frac{R}{2}: (Z'')^2 + (Z' - \frac{R}{2})^2 = \frac{R^2}{4}.$$

The location of the point representing the complex number Z can be also specified by the polar coordinates r and φ . In this specification the magnitude $r = \sqrt{(Z')^2 + (Z'')^2}$ is called the modulus (or the absolute value) of Z , and $\varphi = \arctg(Z''/Z')$ is called the argument of Z [iii].

Refs.: [i] Bermant AF, Aramanovich IG (1975) *Mathematical analysis*. Mir, Moscow, p 238; [ii] Brett CMA, Oliveira Brett AM (1998) *Electrochemistry*. Oxford University Press, Oxford, p 409; [iii] Sluyters-Rehbach M (1994) *Pure Appl Chem* 66:1831

MLo

Complex variable and number — When x and y are two real variables, then $z = (x + iy)$, with $i = \sqrt{-1}$, is a complex variable. When a and b are real numbers, then $c = (a + ib)$ is a complex number. A is called the real part and ib is the imaginary part. See also \rightarrow impedance, \rightarrow immitance.

FS

Compliance limits — The maximum \rightarrow current or \rightarrow voltage a \rightarrow potentiostat or \rightarrow galvanostat can supply between the \rightarrow working-electrode and the \rightarrow counter electrode.

Refs.: [i] Kelly G, Scully JR, Shoesmith DW, Buchheit RG (2003) *Electrochemical techniques in corrosion science and engineering*. Marcel Dekker, New York, p 36; [ii] Nagy Z (ed) (2005) *Online electrochemistry dictionary*. <http://electrochem.cwru.edu/dict.htm>

YG

Concentration — represents the quantity of matter (mol, g, molecules, or other) per unit of volume (cm^3 , L, m^3 , or other) or mass (kg) or surface area (cm^2 , m^2 , or other). IUPAC recommends the following concentration-related terms:

- 1. Mass concentration** (mass density): symbol γ (or ρ), defined as $\gamma_B = m_B/V$ (m_B mass of B present in the volume V), unit kg m^{-3} .
- 2. Number concentration** (number density of entities): symbol C (or n), defined as $C_B = N_B/V$ (N_B number of entities of B present in the volume V), unit m^{-3} .
- 3. Amount concentration** (concentration): symbol c (or $[B]$), defined as $c_B = n_B/V$ (n_B number

of moles of B present in the volume V), unit mol m^{-3} .*

- Mole fraction (amount of substance fraction, amount fraction):** symbol x (used for condensed phases), y (used for gaseous phases), defined as $x_B = n_B / \sum_A n_A$ (n_B number of moles of B present in a mixture with $n_A \dots n_i$), unit 1.
- Molality:** symbol m , b , defined as $m_B = n_B / m_A$ (n_B number of moles of B present in a volume possessing the mass m_A), unit mol kg^{-1} .
- Volume fraction:** symbol ϕ , defined as $\phi_B = V_B / \sum_i V_i$ (V_B and V_i are the volumes of the respective components prior to mixing), unit 1.
- Surface concentration:** symbol Γ , defined as $\Gamma_B = n_B / A$ (n_B number of moles of B present on the surface area A), unit mol m^{-2} .

For further details see [i].

* In chemistry, the most commonly used unit of amount concentration is still mol L^{-1} (the molarity), frequently abbreviated as M . The so-called 'normality', which was the molarity divided by the chemical valence with respect to a certain reaction, is an obsolete unit banned because of the ambiguity of the valence it refers to.

Ref.: [i] Quack M, Frey J (2005) IUPAC quantities, units and symbols in physical chemistry, 3rd edn. Nov 2005, Pure Appl Chem Manuscript ID PAC-REC-05-11-10

FS

Concentration cells — Cells having \rightarrow electrodes of the same type on both sides, but with differing \rightarrow activities of one or both of the redox forms, are called concentration cells.

For example,

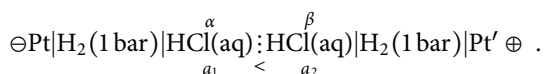

When this cell operates (\rightarrow galvanic cell), an oxidation occurs at the left electrode,



and reduction takes place on the right,

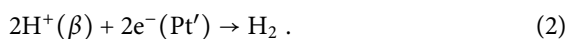

For each mole of electrons passed, 1 mole of H^+ is produced in α , and 1 mole of H^+ is consumed in β . At the

same time H^+ and Cl^- ions migrate across the boundary between α and β . The total amount of H^+ and Cl^- migrating across the boundary is also 1 mole, however, the fractions of current carried by these ions depend on their \rightarrow transport numbers. Note that in concentration cells no net chemical change occurs; only the activities of the electrolytes will be equalized. A concentration cell can also be constructed in such a way that not the concentrations of electrolytes are different but the concentrations of metal, e.g., by using amalgam electrodes. The concentration cells are called **concentration cell with transference** when the migration of ions is allowed. If the cell is reversible for the cation

$$E_{\text{cell}} = -t_{\text{anion}} \frac{RT}{nF} \ln \frac{a_1(\alpha)}{a_2(\beta)} . \quad (3)$$

The concentration change while n mole electron passed is $+(1 - t_{\text{cation}})$ and $-(1 - t_{\text{cation}})$ in the respective compartments.

In these cells a \rightarrow diffusion potential develops between α and β . If the migration of ions is allowed but the diffusion potential is minimized by adding another electrolyte in high concentration (it also causes the decrease of t_{cation} to approximately zero)

$$E_{\text{cell}} = -\frac{RT}{nF} \ln \frac{a_1(\alpha)}{a_2(\beta)} . \quad (4)$$

If reversible electrodes for both the cations and anions are available **concentration cells without transference** can be constructed.

For example,

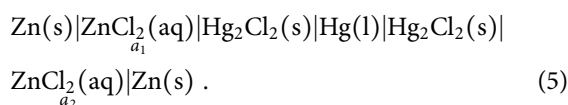

In this case, no diffusion potential develops, consequently

$$E_{\text{cell}} = -\frac{RT}{nF} \ln \frac{a_1}{a_2} . \quad (6)$$

Refs.: [i] Bard AJ, Faulkner LR (2001) Electrochemical methods. Wiley, New York, p 65; [ii] Oldham KB, Myland JC (1994) Fundamentals of electrochemical science. Academic Press, San Diego, pp 79–83

GI

Concentration cells with/without transference \rightarrow concentration cells

Concentration gradient — Change of concentration of a species as a function of location. Caused by localized

generation or consumption of species, e.g., in front of an electrode (i.e., at the electrochemical interface); driving force of transport by diffusion. See also → *diffusion coefficient*, → *diffusion layer*.

RH

Concentration overpotential — The concentration overpotential of an electrode reaction at a given electrode current density is basically the difference in equilibrium potentials across the diffusion layer. More precisely, it is the potential of a reference electrode (of the same → *electrode reaction* as the → *working electrode*) with the interfacial concentrations which establish themselves under direct current flow, relative to the potential of an identical → *reference electrode* with the concentrations of the bulk solution. From such a measured potential difference, with flowing direct current, one has to subtract the ohmic potential drop prevailing between the two electrodes.

Whenever current passes through an electrochemical system, the voltage measured or applied suffers deviation from the equilibrium value due to several factors. The main factors are concentration polarization, activation polarization (→ *activation overpotential*), and → *resistance overpotential*. In contrast to resistance (ohmic) overpotential and activation polarization, concentration overpotential does not vanish immediately with bias interruption, but dissipates as concentration equilibration is attained by convection and diffusion. Concentration overpotential develops in an initially homogeneous solution as a result of current passage due to → *faradaic reactions* that eliminate or produce materials near the working electrode, thus creating concentration gradients between the working and the reference electrode.

There are several mathematical expressions for polarization overpotential for various cases. In non steady-state electrochemical systems the mathematical manipulation of polarization overpotential is not trivial, so as in systems exhibiting chemical reactions preceding the electrochemical ones. For the relatively simple case of steady-state mass transfer, in which insoluble R is produced in the reaction $O + ne^- \rightleftharpoons R$ (e.g., O is a metal ion being electrodeposited) the polarization overpotential is expressed as $\eta_c = \frac{RT}{nF} \ln \left(\frac{j - j_1}{j_1} \right)$ where η_c is the concentration overpotential, R is the → *gas constant*, n the number of electrons that pass in the electrochemical reaction, F is → *Faraday constant*, j is current density, and j_1 is limiting current density. For small potential deviation from equilibrium, namely, for small currents this expression can be simplified by Taylor expansion to $\eta_c = -\frac{RTj}{nFj_1}$.

Only under such “small signal” conditions does the polarization overpotential assume linear correlation with the current density, and resembles an ohmic resistance.

Except for the need to take concentration overpotential into account in electroanalytical studies, it is an important factor for energy losses in electrochemical power sources (e.g., in → *batteries*, *fuel cells*, etc.) and → *electrolysis* (e.g., in electrochemical materials production, → *electroplating*, etc.). Concentration overpotential is called also concentration polarization and mass transfer overpotential.

Refs.: [i] <http://www.iupac.org/goldbook/C01230.pdf#search=concentration%20overpotential>; [ii] Newman J, Thomas-Alyea KE (2004) *Electrochemical systems*. Wiley, New York, pp 18–20; [iii] Hamann C, Hamnett A, Vielstich W (1998) *Electrochemistry*. Wiley-VCH, Weinheim, pp 167–168; [iiii] Bard AJ, Faulkner RL (1980) *Electrochemical methods*. Wiley, New York, pp 26–34

YG

Concentration polarization → *concentration overpotential*, and → *polarization*.

Concentrative refractivity — This is the first derivative of the refractive index of a solution over the concentration of a given species ($\partial n/\partial C$). The variations of the refractive index due to the inhomogeneous spatial concentration of chemical species can be decoupled as: $(\partial n/\partial C) = (\partial n/\partial \rho)_C (\partial \rho/\partial C) + (\partial n/\partial C)_\rho$ where the first term is related to the molecular (or ionic) volume of solvated species and the second one is associated to the electronic structure of such species [i]. The value of $(\partial n/\partial C_j)$ can be considered a constant for rather diluted aqueous solutions and therefore, it is characteristic for each solvated species [ii].

Refs.: [i] Terazima M, Hirota N, Braslavsky S, Mandelis A, Bialkowski S, Diebold G, Miller R, Fournier D, Palmer R, Tam A (2004) *Pure Appl Chem* 76:1083; [ii] Lide DR (2005) *CRC Handbook of chemistry and physics*, vol. 8. CRC Press, Boca Raton, p 58

FG

Concerted electron transfers — (a) Concerted electron transfers occur when the operative → *rate constant* for an → *electron transfer* is comparable to or larger than the rate for the preceding electron transfer. The simplest example is a two-electron transfer (e.g., reduction) where the → *standard potential* E^\ominus for the second electron transfer is more positive than the E^\ominus for the first one [i, ii]. Frequently, the cyclic voltammetric and/or AC responses **look** as if the process is a single (as opposed to a sequential) process. However, careful analysis will usu-

ally indicate that the magnitude and shape of the resultant waves are not consistent with the transfer of a single electron.

(b) A narrower definition of concerted electron transfer requires that n ($=2$, usually) electrons move across a single activation barrier simultaneously, i.e., within some small predefined time window.

Refs.: [i] Nicholson RS, Shain I (1964) *Anal Chem* 36:706; [ii] Evans DH (1998) *Acta Chem Scand* 52:194

SWF

Conditional (apparent) equilibrium constants → *Equilibrium constants* that are determined for experimental conditions that deviate from the standard conditions used by convention in → *thermodynamics*. Frequently, the conditional equilibrium conditions refer to → *concentrations*, and not to → *activities*, and in many cases they also refer to overall concentrations of certain species. Thus, the → *formal potential*, i.e., the conditional equilibrium constant of an electrochemical equilibrium, of iron(II)/iron(III) may refer to the ratio of the overall concentrations of the two redox forms. In the case of → *complex equilibria*, the conditional → *stability constant* of a metal ion M^{m+} with a ligand L^n refers to the overall concentration of all complex species of M^{m+} other than $ML^{(m-n)+}$. Conditional equilibrium constants can be defined for any chemical equilibrium reaction. They are used whenever the activity coefficients and concentrations of the reacting species are not known or not accessible, or when these simplifications are sufficient to treat a certain equilibrium.

Ref.: [i] Kotrlý S, Šůcha L (1985) *Handbook of chemical equilibria in analytical chemistry*. Ellis Horwood, Chichester

FS

Conductance — In electrochemistry, the **electric** conductance is of special importance (compared to thermal conductance). It is the inverse of resistance, and it has the unit ‘siemens’ (S) or ‘reciprocal ohm’, i.e., the ratio of current to terminal voltage. It decreases with the length of the current path and increases with an area of an electrode. Conductance estimated from the ratio of current to voltage is an average value on the assumption of a uniform current distribution. When the charge carrier for conductance are ions and not electrons, a direct current does not pass through the → *interface* between the ionic material and a terminal metal electrode without an → *electron transfer* reaction or any → *faradaic rereaction*. In order to avoid blocking the current through the interface, → *alternating current* is often used for measurement of current or voltage, taking advantage of a capaci-

tor of the diffuse → *double layer* at the interface [i]. Conductance is used as a measure of ion concentrations, e.g., purity of water and in → *titrations*.

See → *conductivity*, → *diffuse double layer*, → *faradaic current*.

Ref.: [i] Atkins PW (1998) *Physical chemistry*. Oxford University Press, Oxford, p 737

KA

Conductimetric sensors → *electrochemical sensors* for which the electrical → *conductivity* of the sensor material is recorded. A typical example is the so-called → *Taguchi sensor* that is used for detection of reducing gases in air.

Ref.: [i] Janata J (1989) *Principles of chemical sensors*. Plenum, New York

JB

Conducting organic salts → *molecular metals*

Conducting polymer-based biosensors → *biosensors*

Conducting polymers — Intrinsically electronically conducting polymers or “synthetic metals” that conduct electricity. The Nobel Prize in Chemistry 2000 was awarded to Alan Heeger, Alan MacDiarmid, and Hideki Shirakawa for the discovery and development of electrically conducting polymers. The most common conducting polymers are polyacetylene, → *polypyrrole*, → *polyaniline*, → *polythiophenes*, → *poly(paraphenylene)*, → *poly(paraphenylene vinylene)*, polycarbazole, and polyamines. The structure of these polymers consists of alternating single and double bonds forming a π -conjugated system by the overlap of carbon p_z orbitals. In order to conduct electricity free charge carriers have to be available. This is achieved by either oxidizing (an electron is removed from the valence band, so-called *p*-doping) or reducing (an electron is added to the conduction band, so-called *n*-doping) the polymer. In case of polyaniline, protonation of the polymer also leads to the doped form. A conjugated polymer can be doped chemically, electrochemically, or photochemically. Electrochemical doping can be made either simultaneously as the polymer is electropolymerized or on chemically synthesized polymers. The created charges are compensated by counter ions present as electrolyte salt in the solution. Photochemical doping is achieved by exposing the polymer to light upon which photons induce charge carriers in the polymer material. Both color changes and conductivity changes take place during doping.

The electrical conductivities of conducting polymer systems range from those of insulators $<10^{-10} \text{ S cm}^{-1}$ to values typical for → *semiconductors* $\sim 10^{-5} \text{ S cm}^{-1}$

close to values for metals $>10^4 \text{ S cm}^{-1}$. Some conducting polymers give rise to fluorescence which has initiated the research on polymer-based light emitting devices. Other possible applications for conducting polymers are organic field effect transistors, electroluminescent and electrochromic devices, solar cells, nonlinear optical devices, batteries, chemical, biochemical, and thermal \rightarrow sensors, drug release systems, electromechanical actuators, switches, corrosion control, and electronic displays.

Refs.: [i] Skotheim TA, Elsenbaumer R, Reynold J (1998) *Handbook of conducting polymers*, 2nd edn. Marcel Dekker, New York; [ii] Inzelt G, Pineri A, Schultze JW, Vorotyntsev MA (2000) *Electrochim Acta* 45:2403; [iii] Inzelt G (1994) *Mechanism of charge transport in polymer-modified electrodes*. In: Bard AJ (ed) *Electroanalytical chemistry*, vol. 18. Marcel Dekker, New York, p 89; [iv] Nalwa HS (ed) (1997) *Handbook of organic conductive molecules and polymers*. Wiley, Chichester; [v] Inzelt G (2008) *Conducting polymers. A new era in electrochemistry*. In: Scholz F (ed) *Monographs in Electrochemistry*. Springer, Berlin

CK

Conducting solids (ion conductors) — comprise a wide class of solid materials where one or more types of \rightarrow ions are mobile. In many cases, this term is used solely for \rightarrow solid electrolytes. Usually, however, the same term can be used for any material with a significant \rightarrow ion \rightarrow conductivity, including \rightarrow mixed ionic–electronic conductors. The phenomenon of ionic conduction is observed for a great number of crystalline solids with an essentially ionic character of bonding, composites, glasses, and amorphous materials [i, ii]. Furthermore, non-negligible ionic conduction is often observed in ceramics where the major phase is insulating, due to transport via \rightarrow grain boundaries and/or extended defects (see \rightarrow defects in solids).

In the simplest and most important cases, two general reasons responsible for ion mobility in solids are (i) the presence of ions or groups of ions with a relatively weak bonding with respect to the neighborhood, and (ii) the existence of a network of positions available for ion jumps. These factors may be quantitatively expressed in terms of ionic \rightarrow charge carrier \rightarrow concentration, and their \rightarrow diffusion coefficient.

The first observations of ionic transport in solids were made by \rightarrow Faraday [iii, iv]. See also \rightarrow Nernst lamp.

One important group of conducting solids is the so-called superionic or fast ion conductors. These are characterized with a relatively high ionic conductivity ($>10^{-2}$ – 10^{-1} S m^{-1}) in substantially disordered crystal lattices and/or near grain boundaries in polycrystalline materials. Typical examples include \rightarrow β -alumina,

\rightarrow NASICON, and \rightarrow BIMEVOX.

See also \rightarrow conductor, \rightarrow superionics.

Refs.: [i] West AR (1984) *Solid state chemistry and its applications*. Wiley, Chichester; [ii] Rickert H (1982) *Electrochemistry of solids. An introduction*. Springer, Berlin; [iii] Faraday M (1833) *Phil Trans Roy Soc (London)* 23:507; [iv] Möbius HH (1997) *J Solid State Electrochem* 1:2

VK

Conduction band — Energy band of a solid is an energy interval with a quasicontinuum distribution of allowed energy levels for \rightarrow electrons. In a \rightarrow semiconductor, the lowest unoccupied energy band at $T = 0$ is denoted conduction band. If the temperature is not zero there is a nonvanishing probability that some electrons will be thermally excited from the \rightarrow valence band across the energy gap into the lowest unoccupied bands, which are called conduction bands. The thermally excited electrons are conduction electrons.

Refs.: [i] Blakemore JS (1987) *Semiconductor statistics*. Dover, New York; [ii] Ashcroft W, Mermin ND (1976) *Solid state physics*. Saunders College, Philadelphia

IH

Conductivity — The conductivity is \rightarrow conductance at unit length and unit area, evaluated from $\kappa = j/(\text{d}\phi/\text{d}x)$, where ϕ is potential at position x and j is the current density.

(a) Conductivity of electrolyte solutions

Conductivity κ of an electrolyte solution, [$\Omega^{-1} \text{ m}^{-1} \text{ S m}^{-1}$]

The conductivity κ of an \rightarrow electrolyte solution depends on the number of cations n_+ and of anions n_- (in the unit [m^{-3}]) in solution, their charge numbers z_+ and z_- , and their \rightarrow mobilities u_+ and u_- (in [$\text{m}^2 \text{ V}^{-1} \text{ s}^{-1}$]) as follows: $\kappa = e_0(n_+z_+u_+ + n_-z_-u_-)$, where e_0 is the \rightarrow elementary electric charge. For an electrolyte $A_{\nu_+}B_{\nu_-}$ forming in solution the ions $A^{(z_+)+}$ and $B^{(z_-)-}$, the \rightarrow electroneutrality condition affords that $\nu_+z_+ = \nu_-z_- \equiv \nu_{\pm}z_{\pm}$, and hence $\kappa = \nu_{\pm}z_{\pm}cN_Ae_0(u_+ + u_-)$, with c being the concentration in [mol L^{-1}], and N_A being the Avogadro number.

Molar conductivity, Λ [$\Omega^{-1} \text{ mol}^{-1} \text{ m}^2 \text{ S mol}^{-1} \text{ m}^2$]

Conductivity κ divided by the molar concentration: $\Lambda = \kappa/c = \nu_{\pm}z_{\pm}N_Ae_0(u_+ + u_-)$.

Equivalent conductivity, Λ_{eq} [$\Omega^{-1} \text{ mol}^{-1} \text{ m}^2 \text{ S mol}^{-1} \text{ m}^2$]

Dividing the molar conductivity by $\nu_{\pm}z_{\pm}$ gives the so-called equivalent conductivity: $\Lambda_{\text{eq}} = N_Ae_0(u_+ + u_-)$. It is discouraged to use that quantity.

See → *conductance*, → *conductivity cell*, → *conductometry*, → *Debye–Falkenhagen effect*, → *Debye–Hückel–Onsager theory*, → *electrolyte*, → *ion*, → *Kohlrausch square root law*, → *mass transport*.

(b) Conductivity of semiconductors → *semiconductors*

(c) Conductivity of metals → *metals*

See also → *conducting solids*, → *solid electrolytes*.

Ref.: [i] Atkins PW (1998) *Physical chemistry*. Oxford University Press, Oxford, p 737

KA

Conductivity cell — (or a cell for → *conductivity* measurements) should be formed, in theory, by two 1 cm² reversible → *electrodes* spaced 1 cm apart, providing a uniform distribution of electrical field. In practice, however, a number of other configurations are used. For liquid → *electrolytes*, the conductivity can be calculated from the → *electrical potential* drop between two electrodes at a given current, using a cell calibrated in order to determine the so-called → *cell constant* K_{cell} [i]. This constant is a factor reflecting particular physical configuration of the cell and fringe-field effects. The theoretical cell described above has $K_{\text{cell}} = 1.0$. The calibration can be performed using a standard solution with known conductivity (e.g. 0.01 M KCl, $\chi_{298\text{ K}} = 1412 \mu\text{cm}^{-1}$).

In the case of → *solid electrolytes*, such a calibration is usually impossible. The configuration of measuring cells should be selected to provide uniform current distribution or to enable use of a definite solution of differential → *Ohm's law* for the conductivity calculations [ii–iv]. The conductivity values are typically verified comparing the data on samples with different geometry and/or electrode arrangement, or using alternative measurement methods.

Both alternating and direct current techniques can be used (see also → *impedance spectroscopy*), but the electrode → *polarization* effects should be minimized or taken into account in all cases. For this goal, a four-electrode method where the potential probes are placed between current probes, is often used.

Refs.: [i] Levine IN (1995) *Physical chemistry*, 4th edn. McGraw-Hill, New York; [ii] Stephens AE, Mackey MJ, Sybert JR (1971) *J Appl Phys* 42:2592; [iii] Warner TE, Edwards PP, Timms WC, Fray DJ (1992) *J Solid State Chem* 98:415; [iv] Van Herle J, McEvoy AJ, Thampi RK (1994) *J Mater Sci* 29:3691

VK

Conductometry — is a nonselective analytic method based on monitoring → *conductivity* of a physical mixture, a solution or a homogeneous → *solid material*. This

method is widely used for binary → *electrolyte* solutions, particularly to determine solubility of a component. One modification, often called the conductometric → *titration*, is a volumetric analytic technique where the equivalence point is determined using a conductivity appliance. See also → *conductivity cell*.

Ref.: [i] Bagotsky VS (2005) *Fundamentals of electrochemistry*, 2nd edn. Wiley, New York

VK

Conductometric titration — A → *titration* method in which the electrical conductivity of a solution is measured as a function of the volume of → *titrant* added. The method is based on replacing an ionic species of the → *analyte* with another species, corresponding to the titrant or the product of significantly different conductance. Thus, a → *linear titration curve* is plotted to obtain the → *end point*. This method can be used for deeply colored or turbid solutions. It does not require knowing the actual specific conductance of the solution, and only few data points far from the end point are necessary. This is to avoid effects such as hydrolysis or appreciable solubility of the reaction product that give rise to curvature in the vicinity of the end point [i].

Ref.: [i] Kellner R, Mermet JM, Otto M, Widmer HM (1998) *Analytical chemistry*. Wiley-VCH, Weinheim

FG

Conductor — is a qualitative term reflecting the capability of a substance to conduct an electrical → *current*. Depending on the type of sole or prevailing → *charge carriers*, → *solid materials* can be classified into **ionic**, **electronic**, and **mixed ionic–electronic conductors**.

The class of electronic conductors, where the ion → *transport number* is zero or negligibly small, comprises metals, → *semiconductors* and → *dielectrics*. Metals are characterized by a high conductivity level ($>10^6$ – 10^7 S m^{-1}) and a negative temperature coefficient. Semiconductors exhibit a lower specific → *conductivity* (10^{-8} – 10^6 S m^{-1}) and, typically, temperature-activated transport.

The class of **ionic conductors** is not unambiguously defined in literature. Depending on context, this term may be used either for → *solid electrolytes* where the ion transference number is higher than 0.99, or for any solid material where ions are mobile, including **mixed ionic–electronic conductors** where the partial ionic and electronic diffusivities are comparable. The latter term is used for materials where the ion transference numbers are lower than 0.95–0.99, and also in conditions when a minor contribution to the total conductivity (ionic or

electronic) cannot be neglected.

Refs.: [i] Bagotsky VS (2005) *Fundamentals of electrochemistry*, 2nd edn. Wiley, New York; [ii] Rickert H (1982) *Electrochemistry of solids. An introduction*. Springer, Berlin; [iii] Chebotin VN (1989) *Chemical diffusion in solids*. Nauka, Moscow

VK

Conductor: first-class and second-class conductors —

The classification of electrical → *conductors* in **first-class** and **second-class conductors** refers to the effect that a → *direct current* has on the integrity of the conductor: first-class conductors are those which do not disintegrate, i.e., are conductors in which → *electrons* or → *holes* are responsible for the conduction, whereas second-class conductors are those where ions are the responsible charge carriers, and disintegration of the conductor occurs at the electrode → *interface* due to → *electrolysis*. The terms first- and second-class conductors should not be used anymore, because more precise terms, i.e., electronic and ionic conductors are available (→ *electronic current*, → *ionic current*), and also because the discussed properties are true only for direct currents whereas an → *alternating current* can flow through an ionic conductor without electrolysis. Further, a direct current can even pass through a → *solid electrolyte* without decomposition of the ionic conductor, e.g., in case of the → *Nernst lamp*, where oxygen is reduced at the cathode and oxygen is evolved at the anode with a → *stabilized zirconia solid electrolyte in-between*.

See also → *electrolyte*, → *solid electrolyte*.

FS

Configurational Gibbs energy → Gibbs energy

Confocal Raman spectroscopy → spectroscopy

Conproportionation or synproportionation — The reverse of → *disproportionation*.

Ref.: [i] Muller P (1994) *Pure Appl Chem* 66:1077

WK

Constant-current (or controlled current (CC-), or galvanostatic) techniques — Electrochemical experiments where the → *faradaic current* passing between anode and cathode is kept constant or changed in a controlled way using a → *galvanostat*. As a response, potential of the working electrode or charge passed through the system (in coulombs) is followed as a function of time. (→ *chronopotentiometry*, galvanostatic → *coulometry*, controlled current → *electrolysis*). See also → *galvanostatic technique*.

Ref.: [i] Bard AJ, Faulkner LR (2001) *Electrochemical methods*, 2nd edn. Wiley, New York, chap 8, pp 305, chap 11.4, pp 430

JL

Constant phase angle — The phase angle is the angle between two phasors that rotate with the same → *angular velocity*. The constant phase angle is independent of angular velocity. For a solitary → *resistor* the phase angle is zero, and for a solitary → *capacitor* it is $\pi/2$.

Ref.: [i] Macdonald JR (1987) *Impedance spectroscopy*. Wiley, New York

MLo

Constant phase element — A constant phase element (CPE) is an electronic → *circuit* element that is characterized by a constant phase angle which is smaller than $\pi/2$ and larger than zero [i]. The → *admittance* of a CPE is given by the equation $Y = Q^0 (i\omega)^{1-\alpha_f}$, where $i = \sqrt{-1}$, $0 \leq \alpha_f \leq 1$ and $Q^0 = |Y|$ at $\omega = 1 \text{ rad s}^{-1}$. The units of Q^0 are $\text{S s}^{1-\alpha_f}$. The phase angle of a CPE is independent of the frequency and has the value $(1 - \alpha_f) \cdot \pi/2$. If $\alpha_f = 0$, a CPE is identical to a → *capacitor* ($Q^0 = C$): $Y = i\omega C$.

The → *complex plane plot* of the → *admittance* of a solitary CPE is a straight line which makes an angle of $(1 - \alpha_f) \cdot \pi/2$ with the Y' axis.

For the parallel connection of a CPE with a → *resistor* R , the → *impedance* is $Z = \frac{R}{1 + (i\omega CR)^{1-\alpha_f}}$, and its real and imaginary parts are [ii]:

$$Z' = \frac{R \left[1 + (\omega CR)^{1-\alpha_f} \cos \frac{(1-\alpha_f)\pi}{2} \right]}{1 + 2 (\omega CR)^{1-\alpha_f} \cos \frac{(1-\alpha_f)\pi}{2} + (\omega CR)^{2(1-\alpha_f)}}$$

$$Z'' = \frac{R (\omega CR)^{1-\alpha_f} \sin \frac{(1-\alpha_f)\pi}{2}}{1 + 2 (\omega CR)^{1-\alpha_f} \cos \frac{(1-\alpha_f)\pi}{2} + (\omega CR)^{2(1-\alpha_f)}}$$

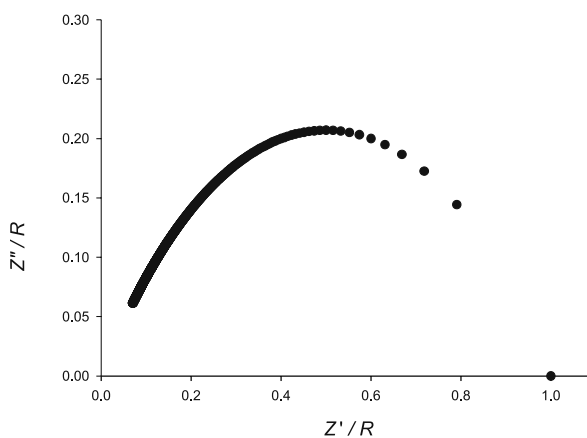

Constant phase element — Figure. Theoretical impedance of a parallel connection of a CPE and a resistor, for $\alpha_f = 0.5$

The complex plane plot of the impedance of the resistor R in parallel with a CPE is a depressed semicircle with the center below the Z' axis.

There are several explanations for the origin of CPE, such as surface roughness, a distribution of \rightarrow reaction rates and a nonuniform current distribution.

Refs.: [i] Retter U, Lohse H (2002) *Electrochemical impedance spectroscopy*. In: Scholz F (ed) *Electroanalytical methods*. Springer, Berlin, p 149; [ii] Jovič VD (2003) http://www.gamry.com/App_Notes/PDF/jovic.pdf

MLo

Constant-potential (or controlled potential (CP-), potentiostatic) techniques — Electrochemical experiments where the potential of the \rightarrow working electrode is kept constant or changed in a controlled way according to a predetermined program (linear sweep, steps, rectangular or triangular pulses, sinusoidal signal) using a function generator and \rightarrow potentiostat. As a response, current is measured as a function of potential or time (\rightarrow voltammetry, \rightarrow polarography, \rightarrow chronoamperometry) or charge passed through the system (in coulombs) is followed as a function of time. See also \rightarrow coulometry, and \rightarrow electrolysis.

Ref.: [i] Bard AJ, Faulkner LR (2001) *Electrochemical methods*, 2nd edn. Wiley, New York, chap 5, pp 156, chap 6, pp 226, chap 7, pp 261, chap 11.3, pp 423

JL

Contact adsorption — The adsorption of negatively charged ions (anions) on a negatively charged electrode surface has initially been called \rightarrow specific adsorption because the obvious contradiction to electrostatic (coulombic) models could not be explained by any model. Alternatively this phenomenon has been called superequivalent \rightarrow adsorption, because there is no equivalence between the charge on the metal and in the inner Helmholtz plane (see \rightarrow double layer), but instead the charge brought about by this type of adsorption is actually larger (superequivalent). The latter term provides only a formal description, whereas contact adsorption describes more specifically the mode of adsorption. In this case anions are adsorbed without any \rightarrow solvation shell between ion and metal, i.e., the anion is directly interacting with the metal. As electrostatic forces cannot be effective other modes of interaction must be operative.

Refs.: [i] Bockris JO'M, Reddy AKN (2006) *Modern electrochemistry*. Springer, New York; [ii] Gileadi E, Kirwa-Eisner E, Penciner J (1975) *Interfacial electrochemistry*. Addison Wesley, London

RH

Contact angle — The contact angle is the angle of contact between a droplet of liquid and a flat rigid solid, measured within the liquid and perpendicular to the contact line where three phases (liquid, solid, vapor) meet. The simplest theoretical model of contact angle assumes thermodynamic \rightarrow equilibrium between three pure phases at constant temperature and pressure [i, ii]. Also, the droplet is assumed to be so small that the force of gravity does not distort its shape. If we denote the \rightarrow interfacial tension of the solid–vapor \rightarrow interface as γ_{SV} , the interfacial tension of the solid–liquid interface as γ_{SL} and the interfacial tension of the liquid–vapor interface as γ_{LV} , then by a horizontal balance of mechanical forces ($\theta < 90^\circ$)

$$0 = \gamma_{SV} - \gamma_{SL} - \gamma_{LV} \cos \theta,$$

where θ is the contact angle. This equation is known as \rightarrow Young's equation, and was derived in 1805 [iii]. Thus the contact angle is a measure of the wettability of a solid by a liquid phase; the smaller the contact angle the larger the wettability. An important subset of cases arises when the liquid is water. If the contact angle approaches 0° then the solid is said to be hydrophilic (see \rightarrow hydrophilicity). This commonly occurs on surfaces that form hydrogen bonds with water. If the contact angle is greater than 90° then the solid is said to be hydrophobic. Finally, if the contact angle is greater than $\sim 150^\circ$ then the surface is said to be superhydrophobic. In case of a droplet of oil on the surface of water, Young's equation becomes:

$$\gamma_{WV} \cos \theta_3 = \gamma_{OV} \cos \theta_1 + \gamma_{WO} \cos \theta_2,$$

where each γ term denotes the interfacial tension between adjacent phases. In this three-fluid case (water, vapor, oil) the oil droplet becomes lens-shaped.

Although contact angle is theoretically a function of state (meaning that its value is independent of system history) experimentally it is often found that the system history has a measurable effect. This has led to the pragmatic definition of **advancing** and **receding** contact angles. Typically, advancing contact angles are measured by dipping a solid into a liquid, whereas receding contact angles are measured by withdrawing them again. The different values of contact angle observed are frequently attributed to nonhomogeneities on the solid surface. Contact angles are principally measured by two techniques: a static method based on the imaging of sessile drops, and a dynamic (receding) method [iv] based on weighing a vertical plate as it is withdrawn from the liquid of interest.

Refs.: [i] de Gennes PG (1985) *Rev Mod Phys* 57:827; [ii] Israelachvili JN (1985) *Intermolecular and surface forces*. Academic Press, New York; [iii] Young T (1805) *Phil Trans Roy Soc (London)* 95:65; [iv] Wilhelmy LF (1863) *Ann Phys Chem (Leipzig)* 119:177

C

Contact ion pair → *ion pair*

Controlled growth mercury drop electrode → *static mercury drop electrode (SMDE)*

Convection — Convection is one of the modes of → *mass transport* (see → *transport phenomena*). Contrary to → *diffusion* or → *migration* when transport of the species occurs from one location in solution to another by a molecular mechanism, in the case of convection the movement of whole volume elements of solution takes place.

Convection may occur due to density gradients (natural convection). A density gradient may arise at high currents due to the production or depletion of matter, especially in technical electrolysis and in coulometric experiments. Heating or cooling may also cause density gradients.

Forced convection may be unintentional, e.g., due to the vibration of the building, but usually stirring is applied to enhance the rate of the mass transport process. Stirring can be achieved by stirring the solution with the help of a separate stirrer, or the electrode itself can rotate (→ *rotating disc electrode*), vibrate (→ *vibrating electrodes*), or even simply expand its volume (which is a movement of its surface against the solution) as the → *dropping mercury electrode* does. Convection is also essential in → *coulometry*, and → *electrolysis, flow-through electrodes*, e.g., → *channel electrodes* or → *wall jet electrodes*.

In the case of forced convection the fluid flow can be → *laminar flow* or → *turbulent flow*. The flux of species *i* (*J* or *J_i*/mol s⁻¹ cm⁻²) driven by convection can be given as follows:

$$J_i = c_i v \quad (1)$$

or for one-dimensional motion along the *x*-axis

$$J_i(x) = c_i v(x), \quad (2)$$

where *c_i* is the → *concentration* (mol cm⁻³) and *v* or *v(x)* is the velocity (cm s⁻¹) with which a volume element in solution moves.

When convection is coupled with diffusion (→ *diffusion*, subentry → *convective diffusion*) the appropriate

form of the → *Nernst-Planck equation* has to be solved:

$$\frac{\partial c_i}{\partial t} = D_i \nabla^2 c_i - v c_i, \quad (3)$$

SF where ∇² is the Laplacian operator and *D_i* is the → *diffusion coefficient* of species *i*.

The exact solution of the convection-diffusion equations is very complicated, since the theoretical treatments involve solving a hydrodynamic problem, i.e., the determination of the solution flow velocity profile by using the continuity equation or → *Navier-Stokes equation*. For the calculation of a velocity profile the solution viscosity, densities, rotation rate or stirring rate, as well as the shape of the electrode should be considered.

Exact solution has been derived for the → *rotating disc electrode (RDE)*, and in certain cases for solution stirring.

In the case of a laminar flow, the flow velocity is zero at the plane electrode surface, then continuously increasing within a given layer (it is called → *Prandtl boundary layer*) and eventually reaches the value characteristic to the stirred liquid phase.

For this situation the thickness of the fictitious → *diffusion layer* (*δ*) can be given as follows

$$\delta_0 \sim y^{1/2} \nu^{1/6} D_0^{1/3} [v(y)]^{-1/2}, \quad (4)$$

where *v(y)* is the flow velocity at a distance (*y*) measured parallel with the surface (*y* = 0 is the center of the plane electrode), *ν* is the kinematic viscosity, and *D₀* is the diffusion coefficient of reactant O (note that *δ₀* depends on *D₀*, i.e., it differs for different species).

According to this relationship *δ* varies along the plate, it is highest at the edge of the electrode, consequently a current (*j*) distribution should also be considered:

$$j \sim nFD_0^{2/3} y^{-1/2} [v(y)]^{1/2} \nu^{-1/6} [c_0(x=0) - c_0^*]. \quad (5)$$

If the electrode is disc-shaped, imbedded in a rod of an insulating material, and rotating with an angular velocity *ω_r* (the axis of rotation goes through the center of the disc and is perpendicular to the surface), *δ* is independent of coordinate *y* (see → *rotating disc electrode*).

Refs.: [i] Bard AJ, Faulkner LR (2001) *Electrochemical methods*. 2nd edn. Wiley, New York, pp 28–35, 331–365; [ii] Inzelt G (2002) *Kinetics of electrochemical reactions*. In: Scholz F (ed) *Electroanalytical methods*. Springer, Berlin, pp 38–39; [iii] Levich VG (1962) *Physical hydrodynamics*. Prentice Hall, Englewood Cliffs

Convolution — The convolution (or *faltung*) of two functions, $f(t)$ and $g(t)$, of time is the mathematical operation $\int_0^t f(\tau)g(t-\tau)d\tau$ or equivalently $\int_0^t f(t-\tau)g(\tau)d\tau$. Sometimes a lower limit other than zero, such as $-\infty$, is appropriate. When functions are “folded” together in this way they are said to have been convolved (not “convoluted”!), and the symbol $f(t) * g(t)$ may be used to indicate this.

In the context of \rightarrow *Laplace transformation*, convolution provides a valuable means of inverting the product $\bar{f}(s)\bar{g}(s)$ of two transforms. The Laplace invert is simply $f(t) * g(t)$.

Convolution is used in electrochemistry particularly as a means of converting the faradaic current $I(t)$ into a more useful quantity. In this application, $I(t)$ is most often convolved with $1/\sqrt{\pi t}$, this operation being identical with \rightarrow *semiintegration*, but more complicated functions may also be used. See also \rightarrow *convolution voltammetry*, \rightarrow *deconvolution*.

Refs.: [i] Churchill RV (1972) *Operational mathematics*. McGraw-Hill, New York; [ii] Mahon PJ, Oldham KB (1999) *J Electroanal Chem* 464:1; [iii] Savéant JM, Tessier D (1975) *J Electroanal Chem* 65:57

KBO

Conway, Brian Evans



(Courtesy of W. Pell)

(Jan. 26, 1927, Farnborough, Great Britain – July 9, 2005, Ottawa, Canada) Canadian electrochemist, 1946–1949 Imperial College, London University, thesis on \rightarrow *electrocatalysis* and \rightarrow *corrosion* inhibitors (supervisor J.O’M. Bockris), 1949–1954 Chester-Beatty Cancer Research Institute with J.A.V. Butler on DNA, 1954–1955 post-doc at University of Pennsylvania with J.O’M. Bockris (among other subjects: \rightarrow *proton* \rightarrow *mobility*, the effect of field-induced reorientation of the water molecule), since 1956 professor at the University of Ottawa (Canada), more than 400 publications on physical electrochemistry, electrode kinetics and mechanisms, \rightarrow *electrochemical capacitors*.

Cooper pairs — are the \rightarrow *electron* pairs in superconductors, coupled over a large range (hundreds of nanometers). The transition of a metal into superconducting state on decreasing temperature has the nature of a condensation of the electrons, leaving a **band gap** above them. The **Cooper pair** attraction can be visualized considering the crystal lattice attraction by a passing electron, with a slight displacement toward its path; this attracts another electron passing in the opposite direction. As a result, the electrons act as pairs coupled by lattice vibrations (exchange of **phonons**). The condensation of such pairs behaving like bosons is the basis of the superconductivity theory developed by John Bardeen, Leon Neil Cooper, and John Robert Schrieffer (the \rightarrow *BCS theory*), awarded the Nobel Prize in 1972.

Refs.: [i] Rohlf JW (1994) *Modern physics from α to Ω* . Wiley, New York; [ii] Cyrot M, Pavuna D (1992) *Introduction to superconductivity and high-T_c materials*. World Scientific, London; [iii] <http://nobelprize.org/physics/laureates/1972/bardeen-lecture.html>; [iv] <http://nobelprize.org/physics/laureates/1972/cooper-lecture.html>; [v] <http://nobelprize.org/physics/laureates/1972/schrieffer-lecture.html>

VK

Coordination — The formation of a \rightarrow *covalent bond*, the two shared electrons of which have come from only one of the two parts of the \rightarrow *molecular entity* linked by it, as in the reaction of a Lewis acid and a Lewis base to form a Lewis adduct (\rightarrow *acid–base theories*); alternatively, the bonding formed in this way. In the former sense, it is the reverse of *unimolecular heterolysis*. “Coordinate covalence” and “coordinate link” are synonymous (obsolescent) terms. The synonym “dative bond” is obsolete. (The origin of the bonding electrons has by itself no bearing on the character of the bond formed. Thus, the formation of methyl chloride from a methyl cation and a chloride ion involves coordination: the resultant bond obviously differs in no way from the C–Cl bond in methyl chloride formed by any other path, e.g., by colligation of a methyl \rightarrow *radical* and a chlorine atom.) The term is also used to describe the number of \rightarrow *ligands* around a central atom without necessarily implying two-electron bonds. See also \rightarrow *dipolar bond*, \rightarrow *π -complex*.

Ref.: [i] Muller P (1994) *Pure Appl Chem* 66:1077

WK

Coordination entity — A molecular entity consisting of a central chemical species, usually a metal atom, to which one or more ligands are bonded. The name of anionic coordination entities takes the ending -ate, whereas no distinguishing termination is used for the cationic or neutral ones. The names of the ligands are listed follow-

RH

ing an alphabetical order, before the name of the central atom, and without regard to the charge or the numerical prefix that indicate the number of a kind of → *ligand*. On the contrary, the central atom heads the formula of coordination entities, and then the formally anionic ligands followed by the neutral ligands are indicated. The sets of anionic and neutral ligands are listed in alphabetic order according to the first symbols of their formula. The formula for the entire coordination entity, whether charged or not, is enclosed in square brackets.

Refs.: [i] Muller P (1994) *Pure Appl Chem* 66:1077; [ii] De Bolster MWG (1997) *Pure Appl Chem* 69:1251

FG

Coordination number — The number of bonds that a specified atom or ion forms with electron-donor species. π -bonds are not considered in determining the coordination number [i, ii].

Refs.: [i] Cotton FA, Wilkinson G, Murillo CA, Bochmann M (1999) *Advanced inorganic chemistry*. Wiley-Interscience, New York; [ii] McNaught AD, Wilkinson A (1997) *IUPAC compendium of chemical terminology*, 2nd edn. Blackwell Scientific Publications, Oxford

FG

Coordinatively saturated — A transition metal → *complex* that has formally 18 outer shell electrons at the central metal atom.

Ref.: [i] Muller P (1994) *Pure Appl Chem* 66:1077

WK

Coordinatively unsaturated — A transition metal → *complex* that possesses fewer → *ligands* than exist in the → *coordinatively saturated*. These complexes usually have fewer than 18 outer shell electrons at the central metal atom.

Ref.: [i] Muller P (1994) *Pure Appl Chem* 66:1077

WK

Coprecipitation — The → *precipitation* of a normally soluble substance that is carried down during the precipitate formation of the desired substance. The coprecipitation of a substance arises from processes such as → *adsorption*, → *mixed-crystal formation*, → *occlusion* and/or mechanical entrapment [i].

Ref.: [i] Harris D (2002) *Quantitative chemical analysis*. WH Freeman & Co, New York

FG

Copper cation conductors → *solid electrolyte*

Copper-conducting solid electrolyte → *solid electrolyte*

Copper coulometer → *coulometer*

Coreactant (ECL) → *electrochemiluminescence*, subentry → *coreactant (ECL)*

Corresponding anodic and cathodic peaks — Corresponding anodic and cathodic peaks are those anodic and cathodic current peaks produced by → *cyclic voltammetry* or → *AC voltammetry* which are associated with a single electron transfer or with concerted multiple electron transfers (see → *concerted electron transfer*).

SWF

Corrosion — Corrosion is the degradation of materials by gaseous or liquid environments. Atmospheric corrosion involves the influence of both media on the surface of a solid, often with alternating wet and dry periods. Any kind of material may be attacked like metals, semiconductors, and insulators as well as organic polymers. Large losses are caused by corrosion in modern industrial societies. An estimate suggests losses of 3.5% of the gross national product by corrosion, a third of which may be avoided if all knowledge is taken into account. Traditionally corrosion is subdivided into the attack by dry and hot gases and by electrolytes. Corrosion involves electrode processes which are ruled by the electrode potential and thermodynamic and kinetic factors [i–iv].

See also → *corrosion current density*, → *biocorrosion*, → *corrosion potential*, → *mixed potential*, → *corrosion inhibitor*, → *corrosion protection*.

Refs.: [i] Kaesche H (2003) *Corrosion of metals*. Springer, Berlin; [ii] Vetter KJ (1967) *Electrochemical kinetics*. Academic Press, New York; [iii] Strehblow HH (2000) *Phenomenological and electrochemical fundamentals of corrosion*. In: Schütze M, Cahn RW, Haasen P, Kramer EJ (eds) *Corrosion and environmental degradation*, vol. 1. Wiley-VCH; [iv] Strehblow HH (2006) *Conventional electrochemical test methods*. In: Czichos H, Saito T, Smith L (eds) (2007) *Springer Handbook of Materials Measurement Methods*. Springer. Part D, 12.1 Corrosion, pp 615–639

HHS

Corrosion current density — Anodic metal dissolution is compensated electronically by a cathodic process, like cathodic hydrogen evolution or oxygen reduction. These processes follow the exponential current density-potential relationship of the → *Butler–Volmer equation* in case of their charge transfer control or they may be transport controlled (→ *diffusion* or → *migration*). At the → *rest potential* E_R both → *current densities* have the same value with opposite sign and compensate each other with a zero current density in the outer electronic circuit. In this case the rest potential is a → *mixed potential*. This metal dissolution is related to the corro-

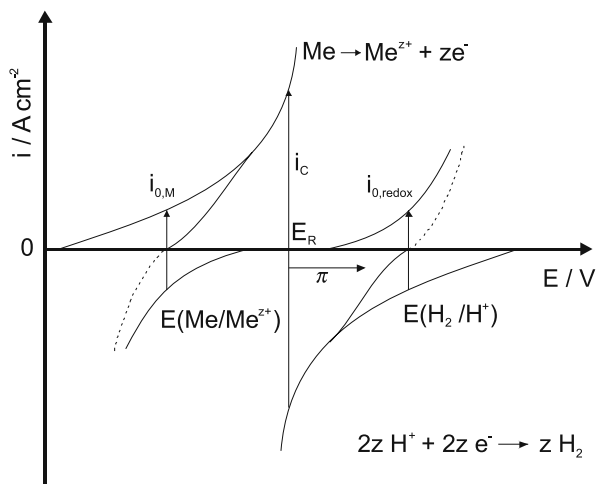

Corrosion — Corrosion current density — Figure. Polarization curves of a metal/metal ion electrode and the H_2/H^+ electrode including the anodic and cathodic partial current curves, the Nernst equilibrium electrode potentials $E(\text{Me}/\text{Me}^{z+})$ and $E(\text{H}_2/\text{H}^+)$, their exchange current densities $i_{0,M}$, $i_{0,\text{redox}}$ and related overpotentials $\eta(\text{Me})$ and $\eta(\text{H})$, the rest potential E_R , the polarization π and the corrosion current density i_c at open circuit conditions ($E = E_R$) [i]

sion current density by \rightarrow Faraday's law. It may be determined by the analysis of the amount of dissolved metal ions within the electrolyte (colorimetry, \rightarrow rotating ring-disk-electrode). Another method is the determination of the \rightarrow polarization curves or the determination of the \rightarrow polarization resistance. The deviation of the rest potential is called polarization $\pi = E - E_R$ and it may be positive or negative (see also \rightarrow Nernst equilibrium potential and \rightarrow exchange current density) (Figure) [i].

Refs.: [i] Strehblow HH (2006) *Conventional electrochemical test methods*. In: Czichos H, Saito T, Smith L (eds) (2007) *Springer Handbook of Materials Measurement Methods*. Springer, Part D, 12.1 Corrosion, pp 615–639

HHS

Corrosion potential \rightarrow corrosion current density

Corrosion inhibitor \rightarrow corrosion inhibitors are chemicals which are added to the \rightarrow electrolyte or a gas phase (gas phase inhibitors) which slow down the \rightarrow kinetics of the corrosion process. Both partial reactions of the corrosion process may be inhibited, the anodic metal dissolution and/or the cathodic reduction of a redox-system [i]. In many cases organic chemicals or compounds after their reaction in solution are adsorbed at the metal surface and block the reactive centers. They may also form layers with metal cations, thus growing a protective film at the surface like anodic oxide films in case of \rightarrow passivity. Benzotriazole is an example for the inhibition of copper cor-

rosion. It forms a three-dimensional layer of copper-benzotriazolate which blocks the metal surface from the direct access of an aggressive electrolyte and thus protects it against oxidation and dissolution.

Ref.: [i] Kaesche H (2003) *Corrosion of metals*. Springer, Berlin

HHS

Corrosion protection — A metal surface may be protected against \rightarrow corrosion by the application of a sufficiently positive or negative \rightarrow electrode potential, corresponding to anodic or cathodic protection. **Anodic protection** usually involves a protective layer which is insoluble within the electrolyte or which dissolves extremely slowly. Passivating oxide layers are an example (see \rightarrow passivity). Copper is passive in alkaline solutions due to its insoluble oxide film. Similarly other more reactive metals are protected at high pH as Ni, Fe etc. These metals are also protected in strongly acidic electrolytes when the oxide films are far from dissolution equilibrium. For these conditions the transfer of metal cations at the oxide/electrolyte interface is extremely slow leading to very small dissolution rates in the range of $\mu\text{A cm}^{-2}$ despite a very positive potential. For these conditions the anodic oxide layer of only a few nm thickness is called a passive layer causing passivity of the metal. Chromium oxides are known to dissolve extremely slowly. Therefore the chromium content of alloys stabilizes the surface of alloys as in the case of stainless steels or Ni/Cr alloys. Cr is enriched within the passive layer which then is stabilized against any attack by the electrolyte even in the presence of chloride which otherwise causes localized corrosion [i–iv].

Cathodic protection leads to sufficiently negative potentials so that metal dissolution does not occur or becomes sufficiently small. This may be achieved by the contact with a very reactive metal. Zinc deposited on iron is a well-known example. The slow dissolution of zinc by hydrogen evolution or oxygen reduction causes a sufficiently negative potential preventing the dissolution of the more noble Fe. A shift of the potential of a metal within the passive potential range to values below the critical potential of pitting may also be seen as a cathodic protection. For these conditions localized corrosion in the presence of chlorides is suppressed [v].

Refs.: [i] Kaesche H (2003) *Corrosion of metals*. Springer, Berlin; [ii] Vetter KJ (1967) *Electrochemical kinetics*. Academic Press, New York; [iii] Strehblow HH (2000) *Phenomenological and electrochemical fundamentals of corrosion*. In: Schütze M, Cahn RW, Haasen P, Kramer EJ (eds) *Corrosion and environmental degradation*, vol. 1, Wiley-VCH; [iv] Strehblow HH (2003) *Passivity of metals*. In: Alkire RC, Kolb DM (eds) *Advances in electrochemical science and engineering*. Wiley-VCH, Weinheim, pp 271–374; [v] Strehblow HH (2002) *Mechanisms of pitting*

corrosion. In: Marcus P (ed) Corrosion mechanisms in theory and practice. Marcel Dekker, New York, pp 243–285

HHS

Corrosion testing — Due to the enormous economic losses by corrosion of materials in industry and private domains predictions of the applicability of metals are a very important demand. One possibility uses electrochemical tests to learn about dissolution rates and special corrosion phenomena like localized corrosion, stress corrosion cracking, intergranular corrosion etc. Other tests expose the materials to conditions which are close to their application. Although electrochemical investigations in combination with surface analytical methods yield deep insight into the effective mechanisms of corrosion phenomena, the environmental conditions are too difficult to get always a clear, simple, easy, and fast answer to existing problems. Therefore several practical standard test methods have been developed in order to obtain reliable predictions for a given situation.

Metal corrosion is a superposition of metal dissolution or the formation of solid corrosion products and a compensating cathodic reaction. Both processes have their own thermodynamic data and kinetics including a possible transport control. Furthermore, metals are generally not chemically and physically homogeneous so that localized corrosion phenomena, local elements, mechanical stress, surface layers, etc. may play a decisive role. Therefore, one approach is the detailed analysis of all contributing reactions and their mechanisms, which however does not always give a conclusive answer for an existing corrosion in practice.

Electrochemical tests allow the determination of a potentiodynamic or potentiostatic polarization curve with the related kinetic parameters, as the standard and rest potential, the exchange current density, and the open-circuit corrosion current density for both the metal dissolution and the cathodic counter reaction of a redox system. These parameters are obtained by appropriate electrochemical measurements of the polarization curve or of the charge transfer resistance or the corrosion resistance. Detailed examination of the metal surface with surface analytical methods like XPS, SEM, EMA, optical microscopy, etc. will give insight to oxide layers or other surface films which influence decisively the corrosion characteristics. In addition, one has to test for special corrosion phenomena like localized corrosion, grain boundary attack, intergranular corrosion, stress corrosion cracking, hydrogen embrittlement etc. For pitting, critical potentials are measured in industry by potentiostatic or potentiodynamic polarization curves. Breakdown of passivity is indicated by a pro-

nounced increase of the anodic dissolution current. The knowledge of these pitting potentials is essential for the application of alloys in practice without their failure for the given environment.

Appropriate methods for the study of the materials' surface have been treated by the keyword Surface Analytical Methods. Especially XPS is a powerful tool even for practical corrosion problems and other problems which may occur at surfaces or surface layers. In many cases one may give solutions to practical problems caused by contaminations, wrong treatment of the surfaces and unexpected surface attack due to changes in the environment. This method has been applied to many practical problems in the macroscopic and microscopic environments ranging from large metal constructions to the micro- and nanoworlds of electronics.

The engineering type of approach asks for fast solutions. Therefore, standardized corrosion tests have been developed with an exposure of metal specimens to real environments or to laboratory conditions which simulate the environmental conditions. In industry and engineering simple weight change measurements are often performed which measure quantitatively the dissolution of metal or the formation of solid corrosion products at the specimens' surface. Special tests have been developed to investigate localized corrosion. In addition to the already mentioned potentiostatic experiments, open-circuit exposure to FeCl_3 -solutions are performed. This test method provides the necessary concentration of aggressive anions which cause breakdown of passivity and pitting corrosion and the given Fe^{3+} concentration causes a potential which usually is positive to the critical pitting potential of the material under study. Pitting is then followed by visual examination of the specimen, weight loss measurements, or open-circuit potential changes with time. A special test is required for intergranular corrosion of Cr-containing steels. The precipitation of Cr-carbides at grain boundaries during heat treatment of the alloys causes a depletion of Cr at their vicinity. As a consequence, the material is preferentially attacked along grain boundaries due to less protection at these sites. Cr-depleted surfaces require a more positive potential for their passivation. If these materials are exposed to an acidic solution like 1M H_2SO_4 the Cr-depleted grain boundaries are attacked in a potential range of 0.1 to 0.5 V, whereas the more Cr-rich part of the surface is passivated and acts as a large cathode of a local element. The Streicher Test uses hot sulfuric acid with dissolved CuSO_4 and added Cu metal chips which causes a potential in the range of intergranular corrosion. The Huey test applies hot nitric acid. However, its

potential is too positive in the range of transpassive dissolution especially of Cr as $\text{Cr}_2\text{O}_7^{2-}$ which therefore is not applicable for the study of intergranular corrosion and the detection of Cr-depleted zones at grain boundaries [1].

Recently, calculations and related long-term predictions of corrosion stability are important issues in corrosion science. The stability of metal containers for radioactive waste in underground depositories is of major interest with predictions for 10,000 years and more. For this purpose calculations involving various scenarios like moisture and presence of water, ions, temperature, geological changes, etc. for the proposed locations and the applied materials are discussed. Depending on the country and site of the depository Cr/Ni alloys, stainless steel, or Cu are proposed as materials for these containers with protecting shields of Ti. These predictions are used as a help to reach the right decisions for the long term storage of the dangerous radioactive waste with safety precautions for later generations of mankind.

Ref.: [i] Kaesche H (2003) *Corrosion of metals*. Springer, Berlin

HHS

Corrugation of liquid|liquid interfaces — Depending on the nature of the two liquids their interface may be more or less corrugated by \rightarrow capillary waves. The structure of liquid|liquid interfaces [i] is of interest for electrochemical studies of \rightarrow ion transfer at liquid–liquid interfaces and \rightarrow electron transfer at liquid–liquid interfaces.

Ref.: [i] Leich MA, Richmond GL (2005) *Faraday Discuss* 129:1

Cottrell, Frederick Gardner



(Reproduced with permission of Research Corporation, Tucson, USA)

(Jan. 10, 1877, Oakland, California, USA – Nov. 16, 1948, Berkeley, California, USA) B.S., University of California at Berkeley, 1896; Ph.D., University of Leipzig, 1902. While pursuing graduate work at Leipzig, Cottrell developed the relationship well known to electrochemists

as the \rightarrow Cottrell equation [i]. In 1903 he returned to the University of California at Berkeley as a Professor of Chemistry. It was there that he developed his best-known invention, the electrostatic precipitator, for removing suspended particles from gas streams. First patented in 1908 (No. 895,729), these devices are still in use today for pollution control. In 1912 Cottrell founded the Research Corporation, a nonprofit foundation for the advancement of science, funded by the income from his patents and those of other inventors. In 1911 he left the University of California to join the U.S. Bureau of Mines as chief physical chemist, becoming Director in 1919. He also became Chair of the division of chemistry and chemical technology of the National Research Council and Director of the Fixed Nitrogen Research Laboratory in the U.S. Department of Agriculture.

Ref.: [i] Cottrell FG (1903) *Z Phys Chem* 42:385

JM

Cottrell equation — Consider a large planar \rightarrow electrode, of surface area A , initially at rest, in contact with a semiinfinite layer of unstirred solution containing excess electrolyte and some small amount of electroactive species R with bulk concentration c_R^b . At the instant $t = 0$, the potential of the electrode is suddenly changed (see \rightarrow chronoamperometry) to a value at which the reaction

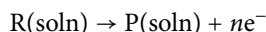

FS

occurs and the concentration of R at the electrode surface is brought to essentially zero. In this equation, n is the number of electrons transferred and can take either sign, being positive for an oxidation and negative for a reduction. If the transport of R to the electrode is solely diffusion controlled then the current is given by

$$I = nFAc_R^b \sqrt{\frac{D_R}{\pi t}},$$

D_R being the diffusion coefficient of species R , and F is the \rightarrow Faraday constant. This equation was first derived by \rightarrow Cottrell [i] and has become known as the Cottrell equation. It shows that the current decays, from an initial infinite value, proportionally as $1/\sqrt{t}$ and, furthermore, that no steady-state current is ever achieved. In actual experimental measurements under these conditions the current in some time regimes can be perturbed by charging current and by the onset of natural convection.

Ref.: [i] Cottrell FG (1903) *Z Phys Chem* 42:385; [ii] Bard AJ, Faulkner L (2001) *Electrochemical methods*, 2nd edn. Wiley, New York, p 161

JM

Coulogravimetry — A combination of \rightarrow *coulometry* and \rightarrow *electrogravimetry*, in which the weight of the deposited analyte and the passed charge are measured [i].

Ref.: [i] Skoog D, West D, Holler F (1996) *Fundamentals of analytical chemistry*. Saunders College Publishing, New York

Coulomb, Charles Augustin de



(June 14, 1736, Angoulême, France – Aug. 23, 1806, Paris, France) The son of Henry Coulomb and Catherine Bajet, he was raised in Angoulême and later in Paris. As a young man he received a classical education at the Collège Mazarin (one of the historic colleges of the University of Paris). Following the estrangement of his parents, he moved to Montpellier in March 1757 to live with his father. However, in October 1758, he returned to Paris to prepare for the entrance examinations for the elite Royal Military Engineering College at Mézières (L'École Royale du Génie de Mézières). He gained entry in February 1760. Its engineering course was notoriously difficult: the first year was devoted to theory, the second year to military exercises. Each student then spent two years allocated to a Regiment and two further years as an intern under a Senior Officer, working on a major project. In February 1764 he was duly posted to Martinique as a second lieutenant, but instead of the projected two-year tour of duty, he actually labored for eight years on the construction of Fort Bourbon. His health deteriorated, and he did not return to France until 1772. Thus, it was not until the age of 37 that he was able to present his first paper to the Académie des Sciences in Paris (in 1773). But it was also an extraordinary paper – it contained solutions to a range of unsolved problems in structural mechanics, mostly obtained by the calculus of variations. A few years later, in 1777, he shared with Jan Hendrik van Swinden (1746–1823) the Grand Prix of the Académie des Sciences for his work on the manufacture and properties of magnetic compass needles. Finally, in 1781, he won the Grand Prix outright for his perceptive study of friction forces, entitled “Théorie des Machines Simples”. He was elected Adjoint Mécanicien of the Académie

des Sciences on 14 December 1781. His scientific career then reached its pinnacle in 1785, when he reported his famous experiments on electricity and magnetism [i]. These involved the use of a high-precision torsion balance “based on the property of metal wires that have a torsion force proportional to torsion angle”. Having successfully developed a means of obtaining highly precise data, he was able to confirm the laws by which both the “magnetic and the electric fluids acted”, whether by repulsion or by attraction. He also realized that electrostatic charges leaked away from seemingly isolated bodies in humid air. In his two most famous experiments, he provided a direct confirmation of the inverse square law for electrical forces, proposed twenty years earlier by Joseph Priestley (Mar. 13, 1733 – Feb. 06, 1804) [ii], and he also confirmed the inverse square law for magnetic forces, which had been suggested by John Michell (Dec. 25, 1724 – Apr. 29, 1793) in 1750 [iii]. Coulomb remained a prominent member of the Corps du Génie until 1791, but within two years he was forced into internal exile near Blois after the Académie des Sciences was abolished by the revolutionary National Convention on Aug. 08, 1793. (Lavoisier, who remained in Paris, was guillotined May 08, 1794.) However, after the National Convention was replaced by the *Directoire*, Coulomb felt confident enough to return to Paris, and was elected Resident Member (1st Class) in the new “Institut de France” on Dec. 09, 1795. He married Louise Françoise LeProust Desormeaux in 1802, and died in 1806. Today, the \rightarrow SI unit of electrical charge, the coulomb (symbol C) is named in his honor.

Refs.: [i] Coulomb, Charles Augustin (1785) *Premier Mémoire, Second Mémoire, Troisième Mémoire sur l'Électricité et le Magnétisme, Histoire de l'Académie Royale des Sciences*, 569, 578, 612. [ii] Priestley, Joseph (1767) *The History and Present State of Electricity, with Original Experiments*. Printed for J. Dodsley et al. (London). [iii] Rivoire, Antoine (1752) *Traité des Aimans Artificiels [...] Fr. translation of Michell's "A Treatise of Artificial Magnets, etc" Chez Hippolyte-Louis Guérin l'aîné, Paris*. See also, Michell, John (1750) *A Treatise of Artificial Magnets, etc*. Printed by Joseph Bentham, and sold by W. and J. Mount et al., Cambridge (UK)

SF

Coulomb — SI-derived measurement unit of electric \rightarrow *charge*. Symbol: C (named in honor of the French physicist \rightarrow *Coulomb*). Definition: 1 coulomb is the amount of electric charge carried by a constant electric \rightarrow *current* of 1 ampere flowing for 1 second. 1 C represents the charge of 6.24×10^{18} electrons. 1 C = 1 As.

Ref.: [i] Cohen ER, Cvitas T, Frey JG (eds) (2006) *IUPAC quantities, units and symbols in physical chemistry*

BM

Coulomb blockade (CB) — That effect is related to the successive transitions of \rightarrow electrons in mesoscopic systems. It was predicted first for solid-state junctions and later for small electrochemical contacts. In general, the CB consists of the blocking of the immediate transition of the second electron after the transition of the first one due to the increase of electrostatic energy of the contact. Most easily this effect is observed at low temperatures in the double tunnel contact with a small metallic particle located between two massive electrodes. The tunneling time through the second contact should be larger than that through the first contact for CB to be observed. The electron, once passed across the first contact will then stay during some time in the metallic particle and the transition of the second electron requires a larger potential drop across the contact. Thus the dependence of the \rightarrow tunneling current I on the \rightarrow potential V is of a step-wise form with the heights of the steps equal to $e/2RC$ where e is the absolute value of the charge of the electron, R and C are the \rightarrow resistance and \rightarrow capacitance of the contact.

In general the CB exists also in molecular systems where the successive transitions of the electrons occur to different molecular energy levels. The main difference between these systems consists in the fact that the steps of the tunneling current in mesoscopic systems are equidistant and determined by the capacitance of the contact, whereas in molecular systems they follow the spacing of the molecular energy levels.

CB was also observed experimentally at room temperature in electrochemical systems.

Refs.: [i] Graber H, Devoret MH (eds) (1992) *Single charge tunneling, Coulomb blockade phenomena in nanostructures*. Plenum, New York, NATO ASI Series B 294; [ii] Kuznetsov AM, Ulstrup J (1993) *J Electroanal Chem* 362:147; [iii] Feldheim DL, Keating CD (1998) *Chem Soc Rev* 27:1; [iv] Templeton AC, Wuelfing WP, Murray RW (2000) *Acc Chem Res* 33:27; [v] Fan FFE, Bard AJ (1997) *Science* 277:1791

AMK

Coulomb force — The Coulomb force is the electrostatic force, i.e., the force that exists between two or more charged bodies. If the bodies are both positively or both negatively charged, the force is repulsive; if they are of opposite charge, the force is attractive. The force is named after \rightarrow Coulomb, who made some early measurements of electrostatic forces using a torsion balance [i]. The magnitude of the Coulomb force F on a point particle of constant \rightarrow charge q_1 due to another point particle of constant charge q_2 may be obtained by multiplying

the electric field caused by q_2 by the charge q_1 ,

$$F = \frac{q_1 q_2}{4\pi\epsilon_r\epsilon_0 d^2},$$

where ϵ_r is the relative \rightarrow permittivity (static \rightarrow dielectric constant) of the surrounding medium, ϵ_0 is the permittivity of free space (8.854×10^{-12} F m⁻¹), and d is the distance between the particles. This is an example of an inverse square law. The corresponding electrostatic potential energy is

$$U = \frac{q_1 q_2}{4\pi\epsilon_r\epsilon_0 d}.$$

In many chemical systems, how the electrostatic potential energy varies with respect to the nuclear coordinates has a strong influence on the rates of electron transfer. All intermolecular forces are electrostatic in origin. This includes all the “named” forces, such as Debye forces, Keesom forces, \rightarrow London forces, and \rightarrow van der Waals forces. These secondary forces arise from spatial distributions of charge (as opposed to point charges), or from temporal fluctuations of charge (as opposed to constant charges), or from combinations of both. In computer simulations of chemical systems, an important adjunct to Coulomb’s Law is the Hellman–Feynman theorem [ii, iii]. This states that, once the spatial distribution of electrons has been determined by solving the Schrödinger equation, the intermolecular forces may be calculated by classical electrostatics. This theorem removes the need for programming secondary forces, but at high computational cost.

Refs.: [i] *Société Française de Physique. Mémoires relatifs à la Physique, tome 1: Mémoires de Coulomb*. Gauthier-Villars, Paris, 1884; [ii] Hellman H (1937) *Einführung in die Quantenchemie*. F Deuticke, Leipzig, p 285; [iii] Feynman RP (1939) *Phys Rev* 56:340

SF

Coulombic efficiency \rightarrow coulometric efficiency

Coulombmeter \rightarrow coulometer

Coulometer — (previously: coulombmeter, or also voltmeter) A coulometer is an instrument to measure charge, i.e., to perform \rightarrow coulometry. Richards and Heimrod [i] suggested in 1902 the name ‘coulometer’ to replace the previously used term ‘voltmeter’. Modern coulometers perform electronic integration of \rightarrow current over time. However, the first coulometers utilized \rightarrow Faraday’s law, e.g., by weighing the amount of silver that has been deposited on a silver electrode in a silver electrolyte solution the charge could be calculated (silver

coulometer, introduced by → *Poggendorff*). Similarly, so-called copper coulometers have been used, although they were inferior with respect to precision. With these coulometers → *electrogravimetry* has been performed for the sake of measuring the electric charge that passed through the → *electrochemical cell*, however, unlike in *electrogravimetry*, great care had to be taken that only one well-defined electrode reaction proceeds at the electrode the weight of which was measured. It is also possible to perform water electrolysis and to measure the volume of produced detonating gas (oxygen–hydrogen mixture) for the sake of charge determination [ii], or to electrolyze a hydrazine solution forming H₂ and N₂ [iii]. For a review of historic coulometers see [iv] and [v].

Coulometers, like the balance, are basic instruments for absolute analysis and they are still used as the most reliable and precise instruments for the analysis of absolute standards. Coulometers are frequently used in elucidating electrochemical reactions because they allow determining the number of transferred electrons when the molar amount of electrolyzed compound is known (→ *Faraday's law*). When the charge is measured as a function of time, the technique is called → *chronocoulometry*. See also → *coulometric titration*.

Refs.: [i] Richards TW, Heimrod GW (1902) *Z phys Chem* 41:302; [ii] Sawyer DT, Sobkowiak A, Roberts JL Jr (1995) *Electrochemistry for chemists*. Wiley, New York, pp 97; [iii] Lingane JJ (1958) *Electroanalytical chemistry*. Interscience, New York, p 456; [iv] Kremann R, Müller R (1931) *Elektromotorische Kräfte. Elektrolyse und Polarisation*. In: *Handbuch der allgemeinen Chemie*. vol. VIII, 2nd part. Walden P, Drucker C (eds), Akadem Verlagsges, Leipzig, pp 8; [v] Delahay P (1954) *New instrumental methods in electrochemistry*. Interscience, New York, pp 398

FS

Coulometric efficiency — The fraction of → *charge* passed for executing a specific, selected electrochemical process divided by the theoretical charge for that process. In the → *battery* field, coulometric efficiency is defined as the ratio between the amount of the electric charge delivered during discharge of a rechargeable battery to the charge consumed for its previous charging. The disparity between the amounts of charge used up by side reactions during charging and discharging and lost also by self-discharge. In the batteries field, coulometric efficiency is also called → *ampere-hour efficiency*, charge efficiency, and coulombic efficiency.

In electrogenerated chemiluminescence (see → *electrochemiluminescence*) coulometric efficiency is related to the amount of photons generated per electrons passing in the electrochemical process. See also → *faradaic efficiency*.

Refs.: [i] Nagy Z (ed) (2005) *Online electrochemistry dictionary*. <http://electrochem.cwru.edu/ed/dict.htm>; [ii] Wugiam M, Jai-Pil C (2004) *Coreactants*. In: Bard AJ (ed) *Electrogenerated chemiluminescence*. Marcel Dekker, New York, p 225; [iii] Crompton TR (2000) *Battery reference book*, 3rd edn. Newnes, Oxford, pp 4/5–4/6, 9/15, 50/5

YG

Coulometric titration — originally developed by → *Szebelledy* and → *Somogyi* in 1938 [i], is a method where the → *titrant* is generated electrochemically either by constant current or at constant potential. The titrant reacts stoichiometrically with the substance being determined. The amount of substance reacted is calculated with → *Faraday's law* from the electric charge required to reach the endpoint. Endpoint detection can be accomplished with → *potentiometry*, → *amperometry*, → *biamperometry* or photometry. Basic requirement is 100% → *current efficiency* of titrant generation at the working electrode. Whereas, in general coulometric → *titrations* show moderate selectivity, detection limits, and rates of analysis, they exhibit the smallest errors and highest reproducibility in many cases. The main advantages are: (a) titration is possible with less stable titrants; (b) the adjustment of titrant is not necessary; (c) the volume of the sample solution is not changed. Almost all titrations can be performed coulometrically: (a) acid–base titrations; protons are produced at a Pt anode or hydroxyl ions at a Pt cathode, (b) → *redox titrations*, (c) → *precipitation titrations* (d) → *complex-formation titrations*. See also → *coulometry*.

In → *solid-state electrochemistry*, and also in the analysis of gases it became customary to call direct → *coulometry* a 'coulometric titration', and the obtained potential-time plots 'titration curves'. In that use electrons are considered as the titrand.

Refs.: [i] Szebelledy L, Somogyi Z (1938) *Z anal Chem* 112:313, 323, 332, 385, 391, 395, 400; [ii] Bard AJ, Faulkner LR (2001) *Electroanalytical methods*, 2nd edn. Wiley, New York; [iii] Stock JT (1984) *Anal Chem* 56:1R

HK

Coulometry — In 1834 → *Faraday* described two fundamental laws of → *electrolysis*. According to Faraday the amount of material deposited or evolved (*m*) during electrolysis is directly proportional to the → *current* (*I*) and the time (*t*), i.e., on the quantity of electricity (amount of → *charge*) (*Q*) that passes through the solution (first law). The amount of the product depends on the equivalent mass of the substance electrolyzed (second law).

(In fact, \rightarrow Faraday's laws are based on two fundamental laws, i.e., on the conservation of matter and the conservation of charge.) Accordingly,

$$m = \frac{M}{nF} Q = \frac{MI t}{nF}, \quad (1)$$

where Q is the amount of charge consumed during the electrochemical transformation, n is the charge number of the electrochemical cell reaction, I is the current, and t is the duration of electrolysis.

If the current efficiency is 100%, i.e., the total charge is consumed only by a well-defined electrode reaction, the measurement of charge provides an excellent tool for both qualitative and quantitative analysis [i, ii]. For instance, knowing m and Q , M/n can be obtained which is characteristic to a given substance and its electrode reaction. By knowing M and n the amount of the substance in the solution can be determined. In many cases – especially in organic \rightarrow electrochemistry – the determination of the number of electrons (n) transferred during the electrode process is of importance regarding the elucidation of the reaction mechanism. For this purpose the total amount of charge necessary for the exhaustive electrolysis of a known amount of substrate has to be determined [iii]. This method is known as coulometry. The coulometric experiment can be carried out at constant potential or at constant current. During coulometry at constant potential the total amount of charge (Q) is obtained by integration of the current (I)–time (t) curve or Q can be determined directly by using a coulometer (electronic integrator). In principle, the end point $I = 0$, i.e., when the concentration of the species under study becomes zero, can be reached only at infinite time, however, in practice; the electrolysis is stopped when the current has decayed to a few percent of the initial values. The change of I and Q as a function of time at a constant potential $|E| \gg |E_e|$, for a stirred solutions and for an uncomplicated electrolysis are as follows:

$$I(t) = I(t=0) \exp\left(-\frac{DA}{\delta V} t\right) \quad (2)$$

and

$$Q(t) = Q(t \rightarrow \infty) \left[1 - \exp\left(-\frac{DA}{\delta V} t\right)\right], \quad (3)$$

where D is the \rightarrow diffusion coefficient of the reacting species, A is the electrode area, δ is the \rightarrow diffusion layer thickness, V is the volume of the solution. The applied potential (E) is far from the respective \rightarrow equilibrium potential (E_e), i.e., the current is diffusion limited. It is also possible to generate a reactant by electrolysis in a well-

defined amount and then it will enter a reaction with a component of the solution. It is used in \rightarrow coulometric titration (\rightarrow Szebellédy) where the endpoint is detected in a usual way, e.g., by using an indicator. A specific variant of coulometric titration is the \rightarrow gas titration used in both liquid and \rightarrow solid electrolytes.

Coulometry at constant current is somewhat more complicated; however, it is usually faster. Its advantage is that the charge consumed during the reaction is directly proportional to the electrolysis time. The change in concentration during electrolysis can conveniently be followed by \rightarrow cyclic voltammetry since the respective peak currents are gradually decreasing. Care must be taken to avoid the potential region where another electrode reaction may start. The n values determined by coulometry may differ from those obtained by a fast technique like cyclic (or linear) sweep voltammetry since the time scales are different, and the primary reaction product may undergo a slow chemical reaction or a second electron transfer may also occur.

Coulometry is, additionally, to gravimetry, a primary standard analysis technique.

Refs.: [i] Inzelt G (2002) Chronocoulometry. In: Scholz F (ed) *Electroanalytical methods*. Springer, Berlin, p 137; [ii] Bard AJ, Faulkner LR (2001) *Electrochemical methods*. Wiley, New York, pp 427–435; [iii] Hammerich O, Svensmark B, Parker VD (1983) In: Baizer MM, Lund H (eds) *Organic electrochemistry*. Marcel Dekker, New York, pp 127–130

GI

Coulostatic techniques — In the coulostatic (or charge step) techniques, a very short-duration (e.g., 0.1 to 1 μ s) current pulse is applied to the cell, and the variation of the \rightarrow electrode potential with time after the pulse at open-circuit condition is recorded [i–v]. The short pulse will charge only the \rightarrow double-layer, and the injected charge (ΔQ) causes a change of the original potential value. In the case of an \rightarrow ideally polarizable electrode the double layer remains charged, and the potential will not decay. However, if a faradaic reaction occurs the double-layer capacitor discharges through the faradaic impedance (\rightarrow impedance, subentry \rightarrow faradaic impedance). Consequently, the open-circuit potential moves back toward its original equilibrium value (E_e). This potential decay is analyzed for different cases.

At the end of charging

$$E(t=0) - E_e = \eta(t=0) = -\frac{\Delta Q}{C_d}, \quad (1)$$

where $E(t=0)$ and $\eta(t=0)$ are the \rightarrow electrode potential and the \rightarrow overpotential, respectively, just after the charging, i.e., those are the initial values at the beginning of

the potential decay ($t = 0$), and C_d is the \rightarrow double-layer capacitance of the electrode. Since the \rightarrow faradaic current (I_F) is equal to the \rightarrow capacitive (charging) current (I_c)

$$\eta(t) = \eta(t=0) + C_d^{-1} \int_0^t I_F dt. \quad (2)$$

When the potential step is small and the system is chemically reversible three cases of interest are analyzed. First, when the reaction is kinetically sluggish (electrochemically \rightarrow irreversible or quasireversible) and the \rightarrow mass transport effects are negligible.

Since in this case $\eta \ll RT/nF$ the $I-\eta$ relation can be linearized. By solving the respective equation for the time decay of η a simple, exponential relationship can be derived

$$\eta(t) = \eta(t=0) \exp(-t/\tau), \quad (3)$$

where the relaxation time (τ) constant determined by the rate of the charge-transfer reaction is equal to

$$\tau = \frac{RTC_d}{nFj_o} = R_{ct}C_d, \quad (4)$$

where j_o is the \rightarrow exchange current density and R_{ct} is the \rightarrow charge-transfer resistance.

By plotting $\ln(\eta)$ vs. t from the intercept $[\eta(t=0)]C_d$, while from the slope R_{ct} and j_o can be determined.

For \rightarrow reversible reaction (\rightarrow nernstian electrode), i.e., when j_o is high and R_{ct} is small compared to the \rightarrow mass transport \rightarrow impedance the following expression applies:

$$\eta(t) = \eta(t=0) \exp(t/\tau_D) \operatorname{erfc} \left[(t/\tau_D)^{1/2} \right]. \quad (5)$$

And

$$\tau_D^{1/2} = \frac{RTC_d}{n^2 F^2} \left(\frac{1}{c_O^* D_O^{1/2}} + \frac{1}{c_R^* D_R^{1/2}} \right), \quad (6)$$

where c_O^* and c_R^* are the bulk concentrations of the oxidized and reduced forms, τ_D is the time constant of the diffusional mass-transport-controlled relaxation, and D_O and D_R are the respective diffusion coefficients.

When both the charge transfer and mass transport terms are significant a more complicated relationship is valid:

$$\eta(t) = \eta(t=0) (\gamma - \beta)^{-1} \left[\gamma \exp(\beta^2 t) \operatorname{erfc}(\beta t^{1/2}) - \beta \exp(\gamma^2 t) \operatorname{erfc}(\gamma t^{1/2}) \right] \quad (7)$$

$$\beta = \frac{\tau_D^{1/2}}{2\tau} + \frac{[(\tau_D/4\tau) - 1]^{1/2}}{\tau^{1/2}} \quad (8)$$

$$\gamma = \frac{\tau_D^{1/2}}{2\tau} - \frac{[(\tau_D/4\tau) - 1]^{1/2}}{\tau^{1/2}}. \quad (9)$$

It follows that $\beta + \gamma = \tau_D^{1/2}/\tau$ and $\beta\gamma = \tau^{-1}$. In the case of a large potential step when $E(t=0)$ will be in the region of the \rightarrow diffusion-limited current:

$$\Delta E = E(t) - E(t=0) = \frac{2nFAD_O^{1/2}c_O^*t^{1/2}}{\pi^{1/2}C_d}. \quad (10)$$

From the slope of ΔE vs $t^{1/2}$ plot the solution concentration or D_O can be calculated, providing that C_d is independent of potential.

There are two advantages of the coulostatic method in the study of kinetics of electrode reactions. First, the ohmic drop is not of importance, therefore the measurements can be carried out in highly resistive media. Second, since $I_c = I_F$, C_d does not interfere in the measurement. By the help of this technique j_o values up to about 0.1 A cm^{-2} and \rightarrow standard rate constants up to 0.4 cm s^{-1} can be determined. A detailed discussion of coulostatic techniques can be found in Ref. [vi].

Refs.: [i] Bard AJ, Faulkner LR (2001) *Electrochemical methods*, 2nd edn. Wiley, New York, pp 322–328; [ii] Delahay P (1962) *J Phys Chem* 66:2204; [iii] Delahay P, Aramata A (1962) *J Phys Chem* 66:2208; [iv] Reinmuth WH, Wilson CE (1962) *Anal Chem* 34:1159; [v] Reinmuth WH (1962) *Anal Chem* 34:1272; [vi] van Leeuwen HP (1982) *Coulostatic pulse techniques*. In: Bard AJ (ed) *Electroanalytical chemistry*, vol. 12. Marcel Dekker, New York, pp 159–238

GI

Counter electrode \rightarrow auxiliary electrode

Counter ion — A mobile ion that balances the charge of another charged entity in a solution. It is a charged particle, whose charge is opposite to that of another electrically charged entity (an atom, molecule, micelle, or surface) in question [i]. Counter ions can form electrostatically bound clouds in the proximity of ionic macromolecules and in many cases, determine their electric properties in solution [ii].

Refs.: [i] Naji A, Jungblut S, Moreira AG, Netz RR (2005) *Physica A: Statistical Mechanics and its Applications* 352:131; [ii] Hunter RJ (1987) *Foundations of colloidal science*. Clarendon, Oxford

FG

Counter ion condensation \rightarrow polyelectrolytes

Coup de fouet — (crack of the whip, whiplash) A sudden and dramatic voltage excursion during the early stages of charge or discharge of a battery (esp. the lead–acid battery) [i]. The effect can be understood as due to a \rightarrow nucleation overpotential [ii].

Refs.: [i] Pascoe PE, Anbuky AH (2002) *J Power Source* III:304; [ii] Hasse U, Fletcher S, Scholz F (2006) *J Solid State Electrochem*, in press

FS

Coupled chemical reactions in electrochemistry

→ *chemical reactions in electrochemistry*

Covalent bond — A region of relatively high electron density between nuclei which arises at least partly from sharing of electrons and gives rise to an attractive force and characteristic internuclear distance. See also → *coordination*, → *hydrogen bond*, multi-center bond. In electrochemical processes covalent bonds are being formed or ruptured in preceding chemical reactions or following chemical reactions (→ *chemical reactions in electrochemistry*) with respect to the electrode reactions.

Ref.: [i] Muller P (1994) *Pure Appl Chem* 66:1077

WK

C rate → *discharge rate*

Critical micelle concentration — There is a rather well-defined concentration above which the surface of an amphiphile solution becomes saturated and → *micelles* begin to form in solution. This concentration is termed the **critical micelle concentration** or CMC (also C.M.C.) and it is accompanied by rather abrupt changes in the evolution with concentration of a variety of equilibrium or transport properties of the solution, as shown in the figure.

Not all amphiphiles show a CMC; long-chained alcohols or amines do not show the effect and a charged head group, a zwitterionic group, or a rather bulky oxygen-containing hydrophilic group such as amine oxide or sugar residue seem to be necessary, at least in aqueous solution. The effect appears to be → *entropy* driven, with the ΔH^\ominus value being small, at least for model systems with small molecular aggregation numbers (50–100), and often slightly positive, whereas ΔS^\ominus values are very positive, giving a net negative ΔG^\ominus (→ *Gibbs energy*). This suggests that the hydrophobic tails of these molecules gives rise to a strong ordering of the water molecules (→ *iceberg structure*) around isolated molecules, which is relieved on micelle formation, more than compensating for the increase in order associated with the amphiphiles themselves.

Factors affecting the CMC include the number of carbon atoms in the chain (leading to a decrease in CMC as N_C is increased), the addition of indifferent electrolyte (leading generally to an increase in CMC, and may lead

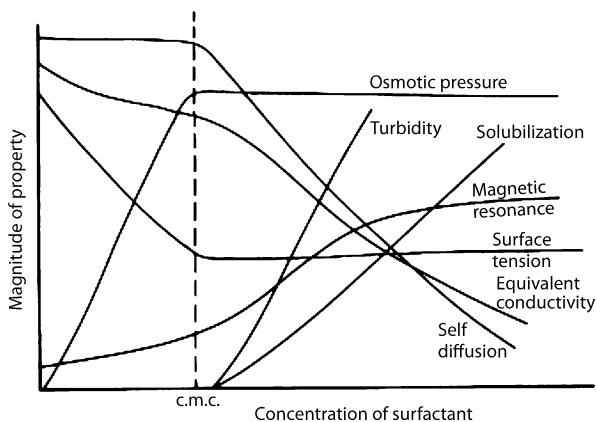

Critical micelle concentration — Figure. (From *Foundations of Colloid Science*; R.J. Hunter)

to changes in micellar structure at higher concentrations of surfactant, including increase in size and transition to rod-shaped structures) and the addition of organic molecules (where solubilization of hydrophobic molecules in the micelles can lead to very complex effects, including minima in such properties as surface tension). Temperature also has a rather complex effect: for ionic surfactants there is a temperature termed the **Krafft temperature** below which micelles do not form and above which there is a rapid increase in surfactant solubility. For non-ionics the behavior is different: as the temperature is raised, the larger aggregates of non-ionic surfactants separate out to form a separate phase above a critical temperature termed the **cloud point**.

Ref.: [i] Hunter RJ (1989) *Foundations of colloid science*. Clarendon Press, Oxford

AH

Crotagino, Friedrich (Fritz)



(Copyright F. Crotagino)

(July 27, 1878, Grabow, Germany, now part of Szczecin, Poland – Dec. 29, 1947, Staßfurt, Germany) Crotagino studied chemistry at the Universities of Breslau and

Clausthal, where he performed, guided by → *Küster, F.W.*, studies on redox potentials. For that research he received his Ph.D. in 1900 at the University of Giessen [i]. He was the first who demonstrated the possibility to follow a → *redox titration* with the help of → *potentiometry* [ii]. Following short periods at the ETH Zurich and University of Breslau, Crotogino worked all his life as a chemist and in leading positions in the industry, mainly in potassium salt fabrication [iii].

Refs.: [i] Crotogino F (1900) *Studien über Oxidationspotentiale*. Ph.D. thesis, University of Giessen, Metzger und Wittig, Leipzig; [ii] Crotogino F (1900) *Z anorg Chem* 24:225; [iii] Crotogino F (1922) *Chemie der Kalisalze*. Verlag von Erich Homuth, Vacha

FS

Crown — A → *molecular entity* comprising a monocyclic → *ligand* assembly that contains three or more binding sites held together by covalent bonds and capable of binding a guest in a central (or nearly central) position. The → *adducts* formed are sometimes known as coronates. The best known members of this group are macrocyclic polyethers, such as “18-crown-6” containing several repeating units –CR–CRO– (where R is most commonly H), and known as crown ethers.

Ref.: [i] Muller P (1994) *Pure Appl Chem* 66:1077

WK

Cruikshank, William Cumberland



(Reproduced with permission of Edgar Fahs Smith Collection, University of Pennsylvania Library)

(1745, Edinburgh, Scotland, UK – June 27, 1800, Scotland, UK) Studied theology at the University of Glasgow and later became a private teacher. Because of his serious interest in medicine he was employed since 1773 by the St. Georges Hospital, and he was awarded the doctor of medicine in 1783. Later he was employed as medical doctor and teacher of anatomy in London and in the administration of the Royal Academy of Artillery at Woolwich. In 1787 he discovered strontium. He is the author of the “The Anatomy of the Absorbing Vessels of the Human Body”. Cruikshank contributed to the early experiments

with the Volta pile. Thus he discovered that metals precipitate in an → *electrolysis* at the negative pole, and he suggested to employ that phenomenon for the purpose of analysis (qualitative determination of copper) [ii].

Refs.: [i] Ostwald W (1896) *Elektrochemie. Ihre Geschichte und Lehre*. Veit, Leipzig; (Engl transl: Ostwald W (1980) *Electrochemistry. History and theory*, 2 vols. Amerind Publ, New Delhi); [ii] Cruikshank WC (1800) *Nicholsons Journal* 4:187

FS

Cruikshank pile — This was a variant of the → *Volta pile* developed by → *Cruikshank*. Rectangular zinc and copper plates are soldered to each other and placed in a trough filled with dilute acid.

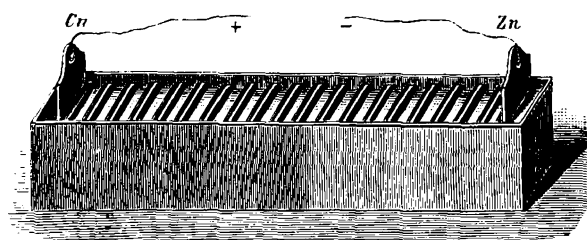

Cruikshank pile — Figure

Ref.: [i] Hauck WP (1883) *Die Galvanischen Batterien, Accumulatoren und Thermosäulen*, 2nd edn. Hartleben's Verlag, Wien

FS

Crystallization — The process of forming solid crystals from solution, melted or polycrystalline phase. Used to separate solid and liquid phase or preparing high purity materials. Crystallization from solution is the most common example of solid–liquid separation. In the process, the solid crystals are formed from supersaturated solution (the solution that contains more soluble molecules, ions etc. that it would under equilibrium conditions). Usually the supersaturated solution is obtained either by cooling the solution, evaporating the solvent, pH change, or adding another solvent. The crystallization process can be induced electrochemically (→ *electrodeposition*, → *electrocrystallization*). The most common example of preparing high-purity materials is the production of ultrapure Si crystals by zone melting (the process where solid Si crystal is melted on one end and the molten zone travels toward the second end of the crystal. As a result the impurities concentrate in the melted zone and are concentrated in one end). Similar technique is used to form metal single crystals. Crystallization generally consists of two steps: nucleation (when

soluble molecules start to form solid clusters, the precursors of the final crystals) and crystal growth (as crystallization proceeds). Those two processes occur simultaneously, with the speed dependent on the conditions.

See also → *crystallization overpotential (polarization)*, → *nucleation and growth kinetics*, → *equilibrium forms of crystals and droplets*, → *half-crystal position*, → *Kaischew*, → *metal deposition*, → *supersaturation*, → *Stranski*, → *Zel'dovich*.

Crystallization overpotential (polarization) — An electrochemical process usually consists of several steps (diffusion in the bulk solution, charge transfer, etc.). During an electrochemical → *metal deposition* one key step is the formation of an → *adatom* on a lattice plane (see Fig. 1). This adatom diffuses to an edge (step) site (Fig. 1, 1→2) and from there to a growth (kink) site (→ *half-crystal position*) (Fig. 1, 2→3) where it becomes a member of the ordered lattice of the solid metal electrode. If the inclusion or the release of adatoms represents the rate-determining step of the metal deposition it is associated with an → *overpotential* (or → *polarization*) and thus is called crystallization overpotential. Assuming that all other processes such as → *diffusion*, → *charge transfer*, and chemical reaction in the electrolyte are in thermodynamic equilibrium the crystallization overvoltage can be defined as: $\eta_c = E(i) - E_{eq} = -\frac{RT}{zF} \ln \frac{a_{M,ad}(i)}{a_{M,ad,eq}}$ where $a_{M,ad}(i)$ and $a_{M,ad,eq}$ are the activities of adatoms at the potentials $E(i)$ and E_{eq} , respectively. The potential $E(i)$ denotes the potential of the electrode under passage of current and E_{eq} is the equilibrium potential. For a (cathodic) metal deposition $E(i) < E_{eq}$ and thus $\eta_c < 0$. If there are enough surface dislocations (e.g., screw dislocations) surface diffusion of the adatoms from the lattice plane to the edge sites (Fig. 1, 1→2) is the rate-controlling step and a concentration gradient exists between the growth step and positions of the lattice plane far from the step, i.e., $a_{M,ad}(i) > a_{M,ad,eq}$. A perfect single crys-

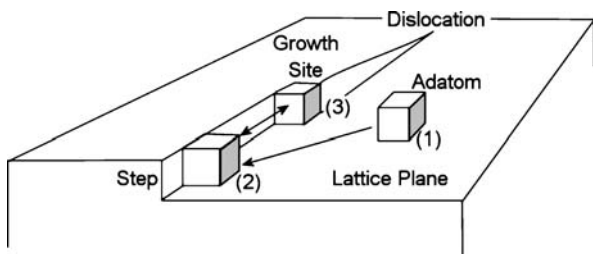

Crystallization overpotential (polarization) — Figure. Schematic representation of the mechanism of a metal deposition

tal face exhibits no growth sites and a 2D → *nucleation* process is required for the deposition of every new layer. Such systems can be held at potentials some mV negative from the → *Nernst* potential without any metal deposition occurring. As the potential is made more negative → *nucleation* of new growth sites occurs. For the system Ag(100)/AgNO₃ a nucleation overvoltage in the range −8 mV to −5 mV has been found [iii].

Refs.: [i] Vetter KJ (1967) *Electrochemical kinetics. Theoretical and experimental aspects*. Academic Press, New York, pp 282–334; [ii] Bockris JO'M, Khan SUM (1993) *Surface electrochemistry. A molecular level approach*. Plenum Press, New York, pp 349–380; [iii] Budevski E, Staikov G, Lorenz WJ (1996) *Electrochemical phase formation and growth. An introduction to initial stages of metal deposition*. VCH, Weinheim, pp 201–261

AB

Curie-von Schweidler law → *dielectric relaxation*

Current — Symbol: I , SI unit: ampere, Symbol: A Current (electric) is the flow of electric charge. The current within a bulk phase comprises macroscopic displacement of charged particles – e.g., movement of electrons in metals, or drift of solvated ions in → *electrolytes*, or displacement of both the electrons and ions in the → *mixed ionic–electronic conductors* (see also → *charge transport*). The current across a boundary of two different conductors may be due either to the charge transfer across the boundary (→ *faradaic current*) or to charge accumulation at the two sides of the boundary (→ *nonfaradaic* or → *charging current*). The current is the amount of charge passing through a hypothetical or real surface per unit time; it is given in ampere (A) units ($1 A \equiv 1 C s^{-1}$). Whenever the current flow is not uniform across the electrode surface, it is characterized by the distribution of the → *current density*.

TP

Catalytic currents (in polarography) — Two types of currents are denoted as catalytic:

1. Limiting currents of a wave of a reversible oxidation–reduction system can be increased in the presence of a catalyst. If the electroactive species is reduced, the increase is observed in the presence of an oxidizing agent. This agent reacts with the reduced form of the redox couple and converts it into an oxidized one, which is again reduced. The size of the increase of the reduction current depends on the rate of the action of the oxidizing agent. In effect, the redox couple causes an electrochemical reduction of the oxidized form of the catalyst. – When in the initial process the reduced form of the

redox couple is electrochemically oxidized, the reduced form can be regenerated from the oxidized one by an action of a catalyst, which in this case is a reducing agent. Under such conditions, the redox couple causes an electrochemical oxidation of the reduced form of the catalyst.

2. Reduction currents, most frequently those of hydrogen ions, that are observed at more positive potentials than currents observed in the absence of the catalyst. The facilitation of the reduction is caused by the catalyst – usually a basic electroinactive compound – which is often adsorbed at the electrode surface. For both types of catalytic currents most information has been obtained for electrolyses using the dropping mercury electrode.
1. Catalytic currents of the first type sometimes called regeneration currents show an increase with increasing concentration of the oxidant. At low concentration of the oxidant, increase of the limiting current as a function of concentration of the oxidant, is first nonlinear, but becomes linear above a certain concentration of the oxidant. As oxidizing agents hydrogen peroxide, chlorate, UO_2^{2+} , and hydroxylamine were used.
2. Catalytic currents of hydrogen evolution are usually observed in buffered solutions. These currents increase with increasing concentration of the buffer at a given pH and with increasing acidity. The plots of current as a function of pH show a sharp increase in current with decreasing pH. This type of catalytic current – at a given pH and buffer composition – increases with increasing concentration of the catalyst, but at a certain concentration the current reaches a limiting value. This value corresponds to a complete coverage of the electrode surface by the catalyst. Such currents are often observed at a very low concentration of the catalyst. For example, in solutions of cobalamin (vitamin B_{12}) they are observed at concentrations as low as 10^{-11} M. They can be used for trace analysis, provided that the sample contains a single catalytically active component. This condition is fulfilled in analyses of some pharmaceutical preparations. They are often useless in analyses of mixtures.

Well-demonstrated examples of practical applications of catalytic currents of hydrogen evolution are analyses of proteins. Those proteins, which contain in their structure one or more sulfur atoms, yield in ammoniacal so-

lutions containing Co(III) a characteristic catalytic double wave. When the samples of sera of patients were denatured in alkaline solutions, treated with sulfosalicylic acid, and filtrated product introduced into an ammoniacal cobalt solution, the height of the catalytic wave is higher in sera of patients suffering from most variants of cancer than in sera of healthy individuals. The method was widely used in the 1950s and 1960s in hospitals in Central Europe as one of the tests in cancer diagnosis.

See also → *catalytic current*, → *catalytic hydrogen evolution*, → *electrocatalysis*.

Refs.: [i] Heyrovský J, Kuta J (1966) *Principles of polarography*. Academic Press, New York; [ii] Bond AM (2005) *Modern polarographic methods in analytical chemistry*. Marcel Dekker, New York; [iii] Galus Z (1994) *Fundamentals of electrochemical analysis*, 2nd edn. Ellis Horwood, New York, Polish Scientific Publisher PWN, Warsaw; (iv) Zuman P, Paleček E (2006) *Perspectives in bioanalysis*, vol. 1. Elsevier, Amsterdam

PZ

Diffusion current — The rate of an → *electrode process* is always determined by one of its consecutive steps (i.e., by the most hindered or 'slowest' one). The → *charge transfer* step is always accompanied by → *diffusion* because, as the reagent is consumed or the product is formed at the electrode, concentration gradients between the vicinity of the interface and the bulk solution arise, which induce diffusion. When the diffusion is the rate-determining step we speak of diffusion kinetics. The → *current* which flows under this condition is called diffusion current.

The flux in the case of → *planar diffusion* can be described by → *Fick's first law*. If the concentration of the species at a given location (x) changes with time (t) Fick's second law should be considered.

The relationship between the → *current density* (j) and the diffusional flux (J_i) is

$$j/nF = -J_i(x=0, t) = D_i \left[\frac{\partial c_i(x, t)}{\partial x} \right]_{x=0}, \quad (1)$$

where D_i is the → *diffusion coefficient* of species i . Fick's equations should be solved in order to obtain the concentrations of the species at a location x and time t . This is possible if the initial (values at $t = 0$) and boundary conditions (values at certain location x) are known.

For steady-state electrolysis conditions, i.e., $[\partial c_i(x, t)/\partial x] = 0$, when the solution is well stirred, and both the reactant and product molecules are soluble, in the case of planar diffusion in x direction, the following relationship is valid:

$$j = nFD_i [c_i^* - c_i(x=0)] / \delta_i \\ = k_{mi} [c_i^* - c_i(x=0)], \quad (2)$$

where c_i^* is the bulk concentration of species i , δ_i is the \rightarrow diffusion layer thickness, and k_{mi} is the \rightarrow mass transport coefficient.

The term $c_i(x=0, t)$ depends on the \rightarrow electrode potential (\rightarrow overpotential).

If the charge transfer is so facile that every reacting species arriving at the electrode surface immediately reacts, then the concentration of the reacting species approaches zero, i.e., $c_i(x=0) = 0$, the current becomes independent of potential, and reaches a maximum value which depends only on the actual hydrodynamic conditions. The maximum current is called the diffusion \rightarrow limiting current (j_L):

$$j_L = nFk_{mi}c_i^* \quad (3)$$

For a \rightarrow rotating disc electrode (RDE) the \rightarrow convective-diffusion equations can be solved which gives the dependence of the diffusion layer thickness on the angular velocity of the rotation (ω)

$$\delta_i = 1.61D_i^{1/3}\omega^{-1/2}\nu^{1/6}, \quad (4)$$

therefore,

$$j = 0.62nFD^{2/3}\omega^{1/2}\nu^{1/6}[c_i(x=0) - c_i^*], \quad (5)$$

where ν is the kinematic viscosity.

Diffusion current is usually measured in the case of several transient electrochemical methods, e.g., in chronoamperometric and chronocoulometric experiments (see \rightarrow chronoamperometry, \rightarrow chronocoulometry, \rightarrow Cottrell equation) as well as it determines the shape of \rightarrow cyclic voltammograms. In these cases the diffusional flux varies with time. The diffusion current density also depends on the size of the electrode (\rightarrow microelectrodes). In \rightarrow electrochemical impedance spectroscopy the \rightarrow Warburg impedance corresponds to the semi infinite diffusion of the charged particles.

See also \rightarrow diffusion overpotential, \rightarrow diffusion time, \rightarrow fractals in electrochemistry, \rightarrow mass transport overpotential, \rightarrow mass transport processes.

Refs.: [i] Inzelt G (2002) Kinetics of electrochemical reactions. In: Scholz F (ed) *Electroanalytical methods*, Springer, Berlin Heidelberg New York, pp 29–47; [ii] Bard AJ, Faulkner LR (2001) *Electrochemical methods*, 2nd edn., Wiley, New York

GI

Faradaic current — A \rightarrow current can flow through the external circuit connecting the \rightarrow electrodes of an \rightarrow electrochemical cell for two reasons. First, electrons or ions cross the electrode-electrolyte \rightarrow interfaces, and these charge transfer steps (\rightarrow charge transfer reaction) are accompanied by oxidation reactions at the

\rightarrow anode and reduction reactions at the \rightarrow cathode. Since such reactions are governed by \rightarrow Faraday's law, i.e., the amount of chemical reaction caused by the flow of current is proportional to the amount of electricity passed, they are called faradaic processes. The current belonging to these processes is called the faradaic current. Second, external currents can flow – at least transiently – when the \rightarrow potential, \rightarrow electrode surface area, or the solution composition changes due to \rightarrow adsorption and/or \rightarrow desorption processes. In the simplest case, changes in the structure of the electrochemical \rightarrow double layer occur (\rightarrow charging current \rightarrow nonfaradaic current). From an electrical point of view the circuit element associated to the faradaic current is a nonlinear resistor.

GI

Limiting currents (in polarography)

Adsorption limiting currents — In the presence of \rightarrow adsorption, separate waves are observed on current-voltage curves at potentials more positive or more negative than the half-wave potential of the corresponding \rightarrow diffusion-controlled wave. Available information is restricted to adsorption currents on current-voltage curves recorded using the dropping mercury electrode. A common characteristic of adsorption currents is their dependence on concentration of the electroactive species. The plots of such currents on concentration are at low concentrations linear, but above a certain concentration reach a limiting value.

For reversible oxidation–reduction systems (\rightarrow reversibility) the adsorption wave is observed at more positive potentials than that of the diffusion-controlled process when the reduced form is adsorbed, at more negative potentials, when the oxidized form is adsorbed. For irreversible processes, the adsorption of both the oxidized or that of the reduced form can either facilitate or hinder reduction or oxidation.

In some cases, like reduction of azulene or for anodic waves, corresponding to mercury salt formations with various ligands, two or even three consecutive adsorption waves can be observed at gradually increased concentration. Two or three adsorbed layers can be formed, which can differ in chemical composition, in number and structure of adsorbed layers, or in orientation of compounds in such layers.

A more informative electroanalytical technique for investigation of adsorption processes is \rightarrow AC polarography, which among other information enables distinguishing between adsorption of the oxidized, the reduced form, or of both.

Refs.: [i] Heyrovský J, Kuta J (1966) *Principles of polarography*. Academic Press, New York; [ii] Bond AM (2005) *Modern polarographic methods*

in analytical chemistry. Marcel Dekker, New York; [iii] Galus Z (1994) *Fundamentals of electrochemical analysis*, 2nd edn. Ellis Horwood, New York, Polish Scientific Publisher PWN, Warsaw; [iv] Zuman P, Rusling J (2002) *Encyclopedia of surface and colloid chemistry*. pp 4143–4161

PZ

Kinetic limiting currents — These currents are observed when investigating solutions, in which an equilibrium is established between an electroactive form and a species, which is not reduced or oxidized within the studied potential range. If the rate of conversion of the electroinactive species into the form which can be reduced or oxidized, is slower than the transport by diffusion, a kinetic limiting current results. In such situations the limiting current is controlled by the rate of the chemical reaction, conversion of the electroinactive into the electroactive species. The available information is restricted to limiting currents, obtained from current-voltage curves recorded using the → *dropping mercury electrode*. Examples of chemical reactions governing such currents are dissociation of some EDTA complexes, dehydrations of strongly hydrated carbonyl or azomethine compounds, formation of geminal diol anions in oxidation of some aldehydes, or formation of some reducible acids from their conjugate bases. In the latter case, the acid is always more easily reduced (at more positive potentials) than the corresponding base. In oxidations the situation is reversed – the conjugate base is always more easily oxidized (at more negative potentials than the corresponding acid). In all such processes an equilibrium precedes the electron transfer.

Proving the existence of a kinetic current is the best possible under polarographic conditions when the studied kinetic current is lower than about 20% of the theoretical diffusion-controlled limiting current. Such currents are independent of mercury pressure, i.e., height of mercury column. Furthermore, such currents have much higher temperature coefficient (5–10% K⁻¹) than diffusion currents (1.8% K⁻¹).

If the equilibrium constant of the chemical reaction (such as complex stability constant, hydration–dehydration equilibrium constant, or the pK_a of the investigated acid–base reaction) is known, limiting currents can be used to calculate the rate constant of the chemical reaction, generating the electroactive species. Such rate constants are of the order from 10⁴ to 10¹⁰ L mol s⁻¹. The use of kinetic currents for the determination of rate constants of fast chemical reactions preceded even the use of relaxation methods. In numerous instances a good agreement was found for data obtained by these two independent techniques.

Refs.: [i] Heyrovský J, Kuta J (1966) *Principles of polarography*. Academic Press, New York; [ii] Meites L (1965) *Polarographic techniques*, 2nd edn. Wiley Interscience, New York; [iii] Galus Z (1994) *Fundamentals of electrochemical analysis*, 2nd edn. Ellis Horwood, New York, Polish Scientific Publisher PWN, Warsaw; [iv] Zuman P (1969) *Elucidation of organic electrode processes*. Academic Press, New York

PZ

Nonfaradaic current — A current where the chemical entity associated to the charge does not change; the current appears as if it made an electric condenser charged (or discharged); thus we often denote the nonfaradaic currents as → *charging currents*. Currents of adsorption and of double-layer charging belong to the class of nonfaradaic currents. From an electrical point of view, the impedance element associated to the nonfaradaic current is a capacitor.

TP

Peak currents in DC-polarography and voltammetry — Peak currents are observed on current-voltage curves obtained by voltammetry using electrodes with a surface that remains constant during the time-window of the experiment. Such conditions are fulfilled, when solid electrodes are used, but also using a hanging mercury drop electrode or even a dropping mercury electrode at high scan rates. Such curves are obtained when at more positive potentials (for reductions) or at more negative ones (for oxidations) the current is controlled by the rate of transport of the electroactive species to the electrode surface. Then at a certain potential the rate of charge transfer would exceed that of the transport, therefore the latter step becomes rate determining. This causes a gradual decrease of the concentration of the electroactive species in the vicinity of the electrode. Such decrease is manifested by a gradual decrease in current with increasingly negative (for reductions) or positive (for oxidations) potentials. The resulting peak currents depend on the number of electrons transferred, on the rate of the transport to the electrode, and hence on the diffusion coefficient and concentration, on the surface area of the electrode, on the rate of the electrode process, and on the rate of scanning. For a reversible oxidation–reduction system the peak current is given by the → *Randles–Ševčík equation* (at 25 °C):

$$I_p = (2.69 \times 10^5) n^{3/2} \cdot A \cdot D^{1/2} \cdot C \cdot \nu^{1/2},$$

where I_p is the peak current (in amperes), n is the number of transferred electrons, A the surface area of the electrode (in cm²), D the → *diffusion coefficient* of the electroactive species (in cm² s⁻¹), C is the bulk concentration of this species (in mol cm⁻³), and ν the → *scan rate* (in V s⁻¹).

Dependence of peak currents (I_p) on the scan rate (ν) enables distinguishing between diffusion currents ($I_p \sim \nu^{1/2}$), adsorption controlled currents ($I_p \sim \nu$), and kinetic currents ($I_p \neq f(\nu)$).

Refs.: [i] Heyrovský J, Kuta J (1966) *Principles of polarography*. Academic Press, New York; [ii] Bond AM (1980) *Modern polarographic methods of analysis*. Marcel Dekker, New York; [iii] Kissinger PT, Heineman WR (eds) (1996) *Laboratory techniques in analytical chemistry*, 2nd edn. Marcel Dekker, New York; [v] Pleskov YuV, Filinovskii VY (1976) *The rotating disc electrode*. Plenum Press, New York; [vi] Galus Z (1994) *Fundamentals of electrochemical analysis*, 2nd edn. Ellis Horwood, New York, Polish Scientific Publ PWN, Warsaw

Current balance — Historic instrument to measure currents by measuring the repulsive force between metal wire coils through which currents flow. The electromagnetic force is balanced by gravity acting on a known mass. Such instruments have been used for the absolute determination of the ampere (\rightarrow SI base units).

Ref.: <http://physics.kenyon.edu/EarlyApparatus/>

PZ

FS

Current collector — In the battery discipline, a good electron conductor support designed to transfer electrons from the external circuit to the active materials of the cell. Current collectors are usually metal foils or nets that are inert under the operational chemical and electrochemical conditions. In some cases carbon cloth is also used. In secondary \rightarrow lead-acid batteries the chemical nature of the current collectors (plates, grids) is particularly imperative, as it influences the self-discharge and the performance under overcharge and discharge conditions. Frequently, current collectors have also the important role of imparting mechanical stability to the electrodes.

Refs.: [i] Linden D (1994) *Handbook of batteries*, 2nd edn. McGraw-Hill, New York, Appendix A; [ii] Gates Energy Products (1998) *Rechargeable batteries applications handbook (EDN Series for design engineers)*. Elsevier, Newnes, p 274; [iii] Crompton TR (2000) *Battery reference book*, 3rd edn. Butterworth-Heinemann, Oxford, chapters 1, 18, 50

YG

Current compliance \rightarrow compliance limits

Current density — 1. For characterizing interfacial processes \rightarrow current, I , flowing through an interface, is usually normalized with respect to the geometric (projected) interfacial area, A , yielding the current density, j ($j \equiv I/A$), being a scalar quantity of unit $A\ m^{-2}$. Since the current does not necessarily flow uniformly across

an interface, it is useful to define the *local* current density at point p of the interface by $j(p) = \delta I/\delta A$; i.e., by the current flowing through an infinitesimally small unit area. The unevenness of the current density along the interface can be characterized by the $j(p)$ function.

2. The *local* current density function can also be used for characterizing the inhomogeneity of the charge flow within the electrolyte. Disregarding the simple cases (like that of an infinite flat electrode), in the vicinity of an electrode the current flow is uneven within the bulk electrolyte. The local current density, according to the microscopic Ohm's law, $j(x, y, z) = -(1/\rho)\text{grad}(\phi(x, y, z))$ where ρ and $\phi(x, y, z)$ stand for the solution's specific resistance and for the potential map, respectively. Since $\text{div}(j) = 0$, the $\Delta\phi(x, y, z) = 0$ Laplace equation holds for the potential distribution within the electrolyte; the current density distribution is therefore proportional to its gradient field.

Depending on the electrical and transport properties of the interface, primary, secondary, and tertiary current density distributions are defined. The distribution is

- primary, if the interfacial impedance is negligibly small with respect to the solution bulk resistance;
- secondary, if the interfacial impedance is comparable to that of the solution bulk; and the interfacial impedance comprises processes across the double layer (double-layer charging and/or charge transfer) – alternatively, when the overvoltage of the interfacial processes is comparable to the ohmic voltage drop in the solution bulk;
- tertiary, if the interfacial impedance is comparable to that of the solution bulk; and the interfacial impedance stems from diffusion-controlled processes – alternatively, the \rightarrow diffusion overpotential is comparable to the ohmic voltage drop in the solution bulk.

The type and nature of the current density distributions are very important when electroplating is used; for uniform deposits, appropriate conditions e.g., electrolytes of “high throwing power” are needed.

Ref.: [i] Ibl N (1983) *Current distribution*. In: Yeager E, Bockris JO'M, Conway BE, Sarangapani S (eds) *Comprehensive treatise of electrochemistry*, vol. 6. Plenum, New York, pp 239–316

TP

Current efficiency — (\rightarrow faradaic efficiency, current yield) is the ratio between the partial current density j_i , which corresponds to a given \rightarrow electrode reaction and/or

given species, to the total current density j . The integral current yield has similar physical meaning, but is expressed in terms of electrical charges for a definite period of time. When there are no consecutive chemical reactions, the current efficiency is directly related to the product yield via \rightarrow Faraday's law. When the system is close to equilibrium and electrode polarization can be neglected, the current efficiency may be expressed via \rightarrow transport numbers of species i .

Refs.: [i] Bagotsky VS (2005) *Fundamentals of electrochemistry*, 2nd edn. Wiley, New York; [ii] Rickert H (1982) *Electrochemistry of solids. An introduction*. Springer, Berlin

VK

Current followers \rightarrow operational amplifier

Current sampling — Measurement of the current at a specified time. The usual objective is to sample the current in as short a time as possible and this means a sampling time interval that is as short as possible. With modern instrumentation, that interval is defined by the speed of a sample-and-hold device coupled with analog-to-digital (A-to-D) conversion.

AMB

Current-voltage curve — The plotted dependence of current vs. applied potential for a given system; used in many fields of science and technology, for example, as a characterization of electronic elements, either linear (following \rightarrow Ohm's law) or nonlinear (redox systems, semiconductors, discharge lamps). Current-voltage curves are recorded, e.g., in \rightarrow polarography, and \rightarrow voltammetry. The response is highly nonlinear for \rightarrow charge-transfer reactions.

PK

Current step — “The excitation signal used in controlled current techniques in which the potential is measured at a designated time” [i]. See also \rightarrow chronopotentiometry, \rightarrow cyclic chronopotentiometry, \rightarrow staircase voltammetry.

Ref.: [i] Heineman WR, Kissinger PT (1984) In: Kissinger PT, Heineman WR (eds) *Laboratory techniques in electroanalytical chemistry*. Marcel Dekker, New York, pp 129–142

AMB

Current yield \rightarrow current efficiency, \rightarrow faradaic efficiency

Cut-off voltage — The end-point for \rightarrow battery charge or discharge, defined by its \rightarrow voltage. Discharge cut-off voltage is defined both to protect cells from overdischarge, and to set regulation for characterization battery's performance, based on intended application.

Charging cut-off voltage is defined to protect a cell's overcharge and damage. Cut-off voltage is called also cutoff voltage or end-voltage.

Refs.: [i] Crompton TR (2000) *Battery reference book*, 3rd edn. Butterworth-Heinemann, Oxford, 9/8, 30/3, 47/11; [ii] Linden D (1994) *Factors affecting battery performance*. In: Linden D (1994) *Handbook of batteries*, 2nd edn. McGraw-Hill, New York, pp 3.5–3.11; [iii] Carcone JA (1994) *Sealed nickel-cadmium batteries*. In: Linden D (1994) *Handbook of batteries*, 2nd edn. McGraw-Hill, New York, pp 28.1–33.35

YG

Cycle life — The number of charge-discharge cycles a \rightarrow rechargeable battery can go through, at specified conditions, before it reaches predefined minimum performance limits. The cycle-life of any particular rechargeable battery is highly dependent on charge and discharge rates, charge and discharge cut-off limits, DOD (depth of discharge), self discharge rate, and service temperatures.

Refs.: [i] Linden D (1994) *Handbook of batteries*, 2nd edn. McGraw-Hill, New York, Appendix, p A.3.; [ii] Nagy Z (ed) (2005) *Online electrochemistry dictionary*. <http://electrochem.cwru.edu/ed/dict.htm>; [iii] Crompton TR (2000) *Battery reference book*, 3rd edn., Butterworth-Heinemann, Oxford, chap 2–6, Glossary p 4

YG

Cyclic chronopotentiometry — A controlled current technique where the applied \rightarrow current step is reversed at every transition time between cathodic and anodic to produce a series of steps in the potential vs. time plot \rightarrow chronopotentiogram. The progression of transition times is characteristic of the mechanism of the electrode reaction. For example, a simple uncomplicated electron transfer reaction with both products soluble and stable shows relative \rightarrow transition times in the series 1:0.333:0.588:0.355:0.546:0.366... independent of the electrochemical reversibility of the electrode reaction.

Refs.: [i] Bard AJ, Faulkner LR (1980) *Electrochemical methods*, p 266; [ii] Herman HB, Bard AJ (1963) *Anal Chem* 35:1121

AJB

Cyclic deflectogram \rightarrow cyclic voltadeflectogram

Cyclic staircase voltammetry — Cyclic voltammetry using a staircase waveform (instead of a constant $|dV/dt|$). The current response will be a series of transients which are measured by Fourier transform [i] or by sampling near the end of each (staircase) step [ii] thereby, in principle, eliminating or at least minimizing the \rightarrow double-layer charging component. The responses are similar to

but not identical to those obtained using a classical, i.e., a constant $|dV/dt|$, perturbation [ii].

Refs.: [i] Bond AM, Duffy NW, Guo S, Zhang J, Elton D (2005) *Anal Chem* 77:186A; [ii] Bilewicz R, Wikiel K, Osteryoung R, Osteryoung J (1989) *Anal Chem* 61:965

AMB

Cyclic voltadeflectogram — A deflection signal in which the deviation angle (θ) of a probe laser beam is recorded as a function of time and plotted against the potential applied to the \rightarrow working electrode. Usually, a cyclic voltadeflectogram is performed keeping the \rightarrow potential sweep (or scan) rate (ν) constant [i].

Ref.: [i] Barbero CA (2005) *Phys Chem Chem Phys* 7:1885

FG

Cyclic voltadeflectometry (CVD) — A \rightarrow probe beam deflection method in which a \rightarrow cyclic linear potential sweep is imposed to the \rightarrow working electrode at a constant \rightarrow potential sweep (or scan) rate (ν) in order to obtain a deflection-potential curve denominated \rightarrow cyclic voltadeflectogram [i].

Ref.: [i] Barbero CA (2005) *Phys Chem Chem Phys* 7:1885

FG

Cyclic voltammetry — A commonly employed type of \rightarrow voltammetry where measurement of the current response of an electrode to a linearly increasing and decreasing potential cycle is performed [i] (see also \rightarrow staircase voltammetry). The experiment is usually started at a potential where no electrode process occurs (0.2 V in the plot) and the potential is scanned with a fixed scan rate to the switching potential (0.7 V in the plot).

When an electrochemically active compound is present in the solution phase, an anodic current peak at the potential $E_{p,a}$ is detected with the peak current $I_{p,a}$. When the potential is swept back during the reverse scan a further current peak (see $E_{p,c}$) may be observed with

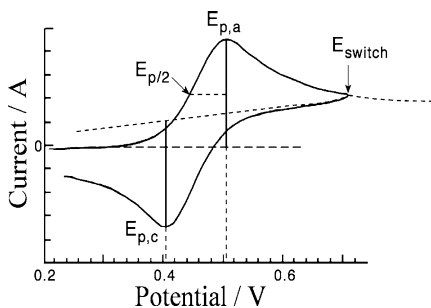

Cyclic voltammetry — Figure 1

a cathodic peak current $I_{p,c}$. The magnitude of the peak current for a reversible electron transfer is given by the \rightarrow Randles–Ševčík equation [ii, iii].

$$I_p = 0.446nFAC\sqrt{\frac{nF\nu D}{RT}}$$

In this equation the peak current I_p is dependent on n , the number of electrons transferred per molecule diffusing to the electrode surface, F , the \rightarrow Faraday constant, A , the electrode area, c , the concentration of analyte in solution, R , the \rightarrow gas constant, T , the absolute temperature, ν , the scan rate, and D , the \rightarrow diffusion coefficient.

Cyclic voltammetry is an excellent technique to survey the reactivity of new materials or compounds and can provide information about (i) the potential at which oxidation or reduction processes occur, (ii) the oxidation state of the redox species, (iii) the number of electrons involved, (iv) the rate of electron transfer, (v) possible chemical processes associated with the electron transfer, and (vi) adsorption effects [iv–vi], etc.

When applied to immobilized redox systems at an electrode surface (or to stagnant solutions in \rightarrow thin-layer cells), cyclic voltammetry produces distinct peak shape and the peak current characteristics.

Symmetric “bell-shaped” oxidation and reduction peaks are observed for \rightarrow electrochemically reversible systems. The peak current now becomes proportional directly to the scan rate.

$$I_p = \frac{n^2 F^2}{4RT} \nu A \Gamma$$

In this equation the peak current I_p is directly proportional to ν , the scan rate, and Γ the surface concentration (for immobilized redox species). In the case of a thin-layer cell the surface concentration has to be replaced by

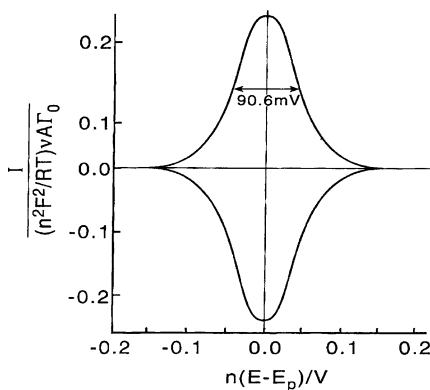

Cyclic voltammetry — Figure 2

cell height \times concentration. Integration of the current versus time allows the number of electrons transferred at the electrode surface to be determined. A plot of the logarithm of peak current versus logarithm of scan rate allows diffusion controlled processes and processes involving surface immobilized redox systems to be distinguished.

Experiments conducted at a range of different scan rates allow the time dependence of processes to be studied. For a “simple” one electron transfer reaction at sufficiently high scan rate the rate of heterogeneous electron transfer will be slow (or “irreversible”) when compared to the duration of the experiment ($\rightarrow E_{\text{irrev}}$ diagnostics, $\rightarrow E_{\text{rev}}$ diagnostics, $\rightarrow E_{\text{rev}}C_{\text{irrev}}$ diagnostics, $\rightarrow E_{\text{rev}}C_{\text{rev}}$ diagnostics). This effect is the cause of the peak-to-peak separation to become wider. A full analysis of a set of voltammograms is possible by \rightarrow digital simulation.

Refs.: [i] Nicholson RS, Shain I (1964) *Anal Chem* 36:706; [ii] Randles JEB (1948) *Trans Faraday Soc* 44:327; [iii] Ševčík A (1948) *Collect Czech Chem Commun* 13:349; [iv] Bard AJ, Faulkner LR (2001) *Electrochemical methods*. 2nd edn. Wiley, New York; [v] Marken F, Neudeck A, Bond AM (2000) *Cyclic voltammetry*. In: Scholz F (ed) *Electroanalytical methods*. Springer, Berlin, p 51f; [vi] Gosser DK (1993) *Cyclic voltammetry: simulation and analysis of reaction mechanisms*. VCH, New York

FM

Cytochrome *c* — Electron carrying protein with a \rightarrow heme functional group. Cytochrome *c* proteins are water soluble and approximately spherical with a diameter of ca. 34 Å consisting of a polypeptide chain with 104 amino acid residues [i]. The heme unit is covalently attached to cysteines and the Fe(III/II) center is ligated by methionine and histidine. The interactions of cytochrome *c* with cytochrome *c* oxidase and reductase are dominated by an electrostatic attraction in which the positively docking region of the cytochrome *c* interacts with negatively charged reaction partners. H.A.O. Hill et al. [ii] demonstrated that this type of interaction can be exploited for the facile electrochemical transfer of electrons to and from cytochrome *c* at negatively charged electrode surfaces. Today horse heart cytochrome *c* is widely employed as a model electrochemical redox protein system, for example, immobilized in mesoporous oxide electrodes [iii].

Refs.: [i] Stryer L (1995) *Biochemistry*. WH Freeman, New York; [ii] Scott RA, Mauk AG (1995) *Cytochrome c*. University Science Books, Sausalito; [iii] Eddowes MJ, Hill HAO (1979) *J Am Chem Soc* 101:446; [iii] McKenzie KJ, Marken F (2003) *Langmuir* 19:4327

FM

Cytochrome oxidase \rightarrow respiration, electrochemical aspects

D

DAC → *digital-to-analog converter*

Dahms–Ruff theory — For fast electron exchange processes coupled to isothermal diffusion in solution, the theoretical description and its experimental verification were given by Dahms [i] and by Ruff and co-workers [ii–v]. Ruff and co-workers studied the displacement of the centers of mass particles, which is brought about by both common migrational motion and chemical exchange reaction of the type

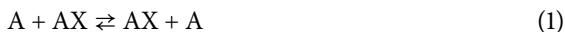

It was concluded that the exchange reaction (→ *electron hopping*) can be described in terms of second-order kinetics, and a relationship was given between the measured → *diffusion coefficient* (D) and the diffusion coefficient (D_0) that would be measured in the absence of any electron exchange reaction:

$$D = D_0 + \frac{k_e \delta^2 \pi}{4} c = D_0 + D_c, \quad (2)$$

where k_e is the second-order rate constant of the exchange reaction and c and δ are the concentration and the distance between the centers of the chemically equivalent species involved in the electron exchange, respectively. In fact, δ is the distance with which the hydrodynamic displacement is shortened for the species and can be determined or at least estimated on the basis of independent data, e.g., the results of neutron scattering.

Later, Ruff, and Botár [vi] corrected the original thermodynamic derivation, which was affected by some errors. According to the corrected thermodynamical treatment, the constant factor in Eq. (2) is $1/6$, $1/4$, or $1/2$ (instead of $\pi/4$) for three-, two-, and one-dimensional diffusion, respectively, i.e.,

$$D = D_0 + k_e \delta^2 c / 6. \quad (3)$$

They also used a random-walk treatment to describe the electron-hopping process coupled to physical diffusion [vii].

Refs.: [i] Dahms H (1968) *J Phys Chem* 72:362; [ii] Ruff I, Friedrich VJ (1971) *J Phys Chem* 75:3297; [iii] Ruff I, Friedrich VJ, Demeter K, Csillag K (1971) *J Phys Chem* 75:3303; [iv] Ruff I, Friedrich VJ (1972) *J*

Phys Chem 76:162; [v] Ruff I, Friedrich VJ (1972) *J Phys Chem* 75:2957; [vi] Botár L, Ruff I (1986) *Chem Phys Lett* 126:348; [vii] Ruff I, Botár L (1985) *J Phys Chem* 83:1292

GI

D

Damascene process — The single or dual damascene copper → *electroplating* method represents one of the nowadays most significant copper processing technologies, which is applied in the microprocessor production for high-quality copper interconnects for integrated circuit chips. Of special importance were the changes of the wiring material from aluminum to copper, as well as from silicon dioxides to newer *low-K* materials (see → *insulator*) in that branch. In damascene processing, the dielectric material is deposited first as a blanket film, and is patterned and etched leaving holes or trenches. In the following step, single, and dual d.p. are distinguished: In the first one, copper is firstly deposited in the holes or trenches surrounded by a thin barrier film, necessary to prevent copper diffusion into the dielectric, resulting in filled vias or wire lines, respectively. In the dual d.p. technology, both the trench and via are fabricated before the deposition of copper, resulting in formation of both the via and line simultaneously. That is, only a single metal deposition step is used to simultaneously form the main metal lines and the metal in the vias. More recently, the number of interconnect levels for logic has substantially increased due to the large number of transistors that are now interconnected in a modern microprocessor. Thus, especially the application of the dual d.p. can reduce the number of processing steps and reduce costs, but nevertheless ensures a performance enhancement.

Refs.: [i] Wolf S (2002) *Silicon processing for the VLSI era, deep-submicron process technology*, vol. 4. Lattice Press, Sunset Beach; [ii] Andricacos PC (1999) *Interface* 8:32; [iii] Stickney JL (2002) *Electrochemical atomic layer epitaxy (EC-ALE): Nanoscale control in the electrodeposition of compound semiconductors*. In: Alkire RC, Kolb DM (eds) *Advances in electrochemical science and engineering*, vol 7. Wiley-VCH, Weinheim, pp 1–106

MHer

Damping — Diminishing of the amplitude of oscillations. Electrical damping of the current oscillations caused by the → *dropping mercury electrode* was used in → *polarography*. Damping is also used to diminish higher-frequency contributions to → *noise*; however, great care has to be taken not to cause over-damping, i.e., to obscure the time-dependence that is supposed to be studied.

FS

Daniell, John Frederic



English scientist (March 12, 1790, London, UK – March 13, 1845, London, UK) The first professor of chemistry at Kings College, London, in 1831. First investigations in batteries coincided with the appearance of commercial telegraph systems. The fast electrode kinetics of the copper and zinc electrodes in the → *Daniell cell* (1836) enabled their use in the rapidly growing telegraph systems employing the Morse code. In 1839 Daniell produced a strong electric arc with a 70-cell battery. He demonstrated that metal ions are carriers of electric charge in a metal–salt solution instead of the metal oxides. He was a friend and admirer of → *Faraday*, to him he dedicated his textbook *Introduction to the Study of Chemical Philosophy* (1839).

Refs.: [i] Magnusson M (ed) (1990) *Chambers biographical dictionary*. W & Chambers, Edinburgh; [ii] Crystal D (ed) (1998) *The Cambridge biographical encyclopedia*. Cambridge University Press, Cambridge

RH

Daniell cell — Electrochemical primary cell composed of a zinc and a copper electrode. Both metals are immersed into aqueous solutions of their respective sulfates (described according to the → *Stockholm convention*), the solutions are separated by, e.g., a porous glass frit:



The cathode reaction is the reduction of copper cations

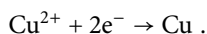

The anode reaction is the oxidation of zinc

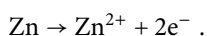

The cell reaction is

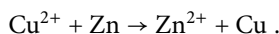

Even under open-circuit conditions diffusion of ions across the separator causes a continuous change of cell voltage despite the reversibility of both electrodes,

a → *liquid junction potential* may be established (For possibilities of suppression see → *salt bridge*). The cell voltage E_{cell} (also infrequently called potential of the cell reaction (→ *Galvanic cell*)) as well as the respective electrode potentials are connected according to

$$E_{\text{cell}} = E_{\text{Cu}^{2+}/\text{Cu}} - E_{\text{Zn}^{2+}/\text{Zn}}$$

with electrodes in their standard state the standard cell voltage can be calculated (also infrequently called → *standard potential* of the cell reaction)

$$\begin{aligned} E_{\text{cell}}^{\ominus} &= E_{\text{Cu}^{2+}/\text{Cu}}^{\ominus} - E_{\text{Zn}^{2+}/\text{Zn}}^{\ominus} = 0.3402 - (-0.7628) \\ &= 1.103 \text{ V} . \end{aligned}$$

The standard free energy (Gibbs energy) of the reaction proceeding in the cell is $\Delta G^{\ominus} = -212.867 \text{ kJ mol}^{-1}$, it is related to the standard cell potential according to

$$\Delta G^{\ominus} = -nFE_{\text{cell}}^{\ominus} .$$

The relationship between the equilibrium constant K_c of a chemical reaction and the standard free energy (Gibbs energy)

$$\Delta G^{\ominus} = -RT \ln K_c$$

(van't Hoff reaction isotherm) provides a value of $K_c = 2.15 \times 10^{37}$. As expected and as well known from the technological → *cementation* process the equilibrium is shifted to the discharge products: copper metal and zinc ions.

The change of the cell voltage as a function of the cell temperature (temperature coefficient) $\partial E_{\text{cell}}^{\ominus} / \partial T = -0.83 \times 10^{-4} \text{ V K}^{-1}$ and the relationship between the standard reaction entropy and the standard free enthalpy of reaction ($\partial \Delta G^{\ominus} / \partial T$)_p = $-\Delta S^{\ominus}$ the value for the cell reaction can be calculated as: $-\Delta S^{\ominus} = -16.02 \text{ J K}^{-1} \text{ mol}^{-1}$.

Refs.: [i] Bockris JO'M, Reddy AKN, Gamboa-Aldeco M (2000) *Modern electrochemistry*, vol. 2A. Kluwer, Dordrecht, p 1356; [ii] Holze R (1989) *Leitfaden der Elektrochemie*. Teubner, Stuttgart; [iii] Handel S (1971) *A dictionary of electronics*. Penguin Books, London; [iv] Rieger PH (1994) *Electrochemistry*. Chapman-Hall, New York, p 2

RH

Dark current — In photovoltaics it means the current measured in → *photovoltaic devices* and photoconductive devices under dark conditions.

IH

D'Arsonval galvanometer — Historic moving-coil → *galvanometer* where a rectangular metal coil is hanging between the horseshoes of a permanent magnet.

A fixed iron core may be situated in the center of the coil.

Refs.: [i] <http://physics.kenyon.edu/EarlyApparatus/>; [ii] Michels W (ed) (1956) *The international dictionary of physics and electronics*. Van Nostrand, Princeton

FS

Davy, Sir Humphry, Baronet



(by an unknown artist after Sir Thomas Lawrence, 1821)

(Dec. 17, 1778, Penzance, Cornwall, UK – May 29, 1829, Geneva, Switzerland) Davy was one of the founders of modern chemistry [i–iii]. He studied electricity, electrical phenomena in chemistry [iv], and connections between → *electricity* and magnetism [v]. Davy elucidated compositions of many compounds (particularly of nitrogen oxides) supporting Dalton's atomic theory. He studied → *electrolysis* of molten salts that resulted in discovery of several new elements (magnesium, calcium, strontium, and barium) in 1808. He also discovered boron (by heating borax with potassium), hydrogen telluride, hydrogen phosphide (phosphine), and two chlorine oxides. Davy was the first to observe that platinum catalyzes the oxidation of alcohol vapor in air. This was one of the earliest demonstrations of catalysis. His research on flame [vi] resulted in the important invention of a safety lamp for miners.

Refs.: [i] Williams HS (1904) *A history of science, vol. 4*. Harper & Brothers, New York, chap 3; [ii] Treneer A (1963) *The mercurial chemist: A life of Sir Humphry Davy*. Methuen, London; [iii] Siegfried R (1961) In: Farber E (ed) *Great chemists*. Interscience Publishers, New York, pp 370–384; [iv] Russell CA (1963) *Annals Sc* 19:255; [v] Davy H (1821) *Phil Trans Royal Soc* 111:7; [vi] Davy H (1817) *Phil Trans Royal Soc* 107:45

EK

DC → *direct current*, and also → *decoupling of AC and DC signals*

DC (Direct current) techniques — Electrochemical experiments where the applied potential (in → *potentiostatic techniques*) or current (in → *galvanostatic tech-*

niques) is constant or changed linearly or stepwise, but not sinusoidally.

JL

DC field → *direct current*

DCP Acronym for **direct current polarography**. See → *polarography*, and subentry → *DC polarography*.

DC polarography → *polarography*, and subentry → *DC polarography*.

DC potential → *direct current*

DC voltammetry — Voltammetry with an applied DC potential that varies, usually, linearly with time. That is, constant $|dV/dt|$ without embellishments of the voltage perturbation as applies, for example, in AC voltammetry. See → *polarography*, and subentry → *DC polarography*.

Refs.: [i] Bond AM (1980) *Modern polarographic methods in analytical chemistry*. Dekker, New York; [ii] Galus Z (1994) *Fundamentals of electrochemical analysis, 2nd edn*. Ellis Horwood, New York, Polish Scientific Publisher PWN, Warsaw

AMB

Dead-stop titration → *biamperometry*

Debije, Petrus Josephus Wilhelmus → *Debye, Peter Joseph Wilhelm*

Debye, Peter Joseph Wilhelm



(© The Nobel Foundation)

(Debije, Petrus Josephus Wilhelmus; Mar. 24, 1884, Maastricht, The Netherlands – Nov. 2, 1966, Ithaca, USA) Dutch physicist, studied physics in Aachen, obtained habilitation in 1910 in Munich, became professor of theoretical physics in Zürich 1911, in Utrecht 1912, in Göttingen 1914, in Zürich again 1920, in Leipzig 1927. In 1935 he became director at the Kaiser-Wilhelm-Institut für Physik in Berlin, since 1939 he taught at Cornell

University in Ithaca. Nobel Prize in 1936 for contributions to the knowledge of molecular structure based on his research on dipole moments, X-ray diffraction (Debye–Scherrer method), and electrons in gases. His investigations of the interaction between ions and electric fields resulted in the → *Debye–Hückel theory*. See also → *Debye–Falkenhagen effect*, → *Debye–Hückel limiting law*, → *Debye–Hückel length*, → *Debye relaxation time*.

Refs.: [i] Magnusson M (ed) (1990) *Chambers biographical dictionary*. W&R Chambers, Edinburgh; [ii] Crystal D (ed) (1998) *The Cambridge biographical encyclopedia*. Cambridge University Press, Cambridge

RH

Debye–Clausius–Mossotti equation → Debye expanded the → *Clausius–Mossotti equation* and related the molar polarization \bar{P} with the → *dielectric constant* ϵ_r , the electron polarizability α of an individual molecule, and the → *dipole moment* $\bar{\mu}$: $\bar{P} = \frac{4}{3}\pi N_0 \left(\alpha + \frac{\bar{\mu}^2}{3kT} \right) = \frac{\epsilon_r - 1}{\epsilon_r + 2} V_m$ (V_m is the molar volume of the compound). The Debye–Clausius–Mossotti equation is applicable only to nonpolar gases at moderate pressure, and to nonpolar solvents and solutes in nonpolar solvents. For polar gases and polar solvents the → *Onsager equation* gives more precise data.

Refs.: [i] Debye P (1912) *Phys Z* 13:97; [ii] Debye P (1929) *Polare Molekeln*. Hirzel, Leipzig; (Debye P (1929) *Polar molecules*. Chemical Catalogue Company, New York); [iii] Kortüm G (1962) *Lehrbuch der Elektrochemie*. Verlag Chemie, Weinheim, pp 121–129

FS

Debye effect (potential difference in electrolyte solution upon ultrasonic radiation) — Sound waves passing through an → *electrolyte* solution result in an alternating electric potential fluctuation, predicted theoretically by → Debye in 1933 [i]. The existence of this “ultrasonic vibration potential” phenomenon was demonstrated experimentally in 1949 by Yeager [ii]. The effect is due to the different mobilities of cations and anions in the sound field and it is measured by placing electrodes into a resonating sound field. The frequency-dependent effect can be used to determine ion association effects and it is commonly employed to determine the properties of charged → *colloids* and → *nanoparticles*. A more recent development is electroacoustic imaging [iii]. See also → *electroacoustics*.

Refs.: [i] Debye P (1933) *J Chem Phys* 1:13; [ii] Yeager E, Bugosh J, Hovorka F, McCarthy J (1949) *J Chem Phys* 17:411; [iii] Beveridge AC, Wang SG, Diebold GJ (2004) *Appl Phys Lett* 85:5466

FM

Debye force → *van der Waals forces*

Debye length — (also: → *Debye–Hückel length*) In the formulation of the → *Debye–Hückel theory* the counter ions surrounding the sample ion under consideration are substituted in an attempt of simplification by an ionic cloud. The radius of this ionic cloud or atmosphere giving the distance between the ion under consideration and the location where $dq/(1/\kappa)$ is at maximum (dq is the charge enclosed in a shell of dr thickness around the ion, and κ is the → *Debye–Hückel parameter*). The Debye length r_D (L_D and other symbols are also used) also is given by

$$r_D = \frac{1}{\kappa} = 1.988 \times 10^{-10} \sqrt{\frac{\epsilon_r T}{I}},$$

where ϵ_r is the relative dielectric → *permittivity* of the solvent, T is the temperature (in K), and I is the → *ionic strength* (concentration given in $[\text{mol L}^{-1}]$). See also → *Gouy length*.

Refs.: [i] Debye P, Hückel E (1923) *Phys Z* 24:185; [ii] Bockris JO'M, Reddy AKN (2006) *Modern electrochemistry*. Springer, New York

RH

Debye–Falkenhagen effect → Debye and → *Falkenhagen* predicted, that in → *electrolyte* solutions the ionic cloud may not be established properly and maintained effectively when the ion and the cloud are exposed to an alternating (AC) electric field in particular of high frequency. Thus the impeding effect of the ion cloud on the ion movement should be diminished somewhat resulting in an increased value of the ionic conductance. Above frequencies of $\nu \sim 10^7$ to 10^8 s^{-1} this increase has been observed, see also → *Debye relaxation time*.

Refs.: [i] Debye P, Falkenhagen H (1928) *Phys Z* 29:401; [ii] Falkenhagen H (1971) *Theory der Elektrolyte*. Hirzel, Leipzig, p 117

RH

Debye–Hückel approximation — In calculating the potential distribution around a charge in a solution of a strong → *electrolyte*, → Debye and → *Hückel* made the assumption that the electrical energy is small compared to the thermal energy ($|z_i e \psi| \ll kT$), and they solved the → *Poisson–Boltzmann equation* $\nabla^2 \psi = -\frac{1}{\epsilon_0 \epsilon_r} \sum_i c_i^0 z_i e \exp\left(\frac{-z_i e \psi}{kT}\right)$ by expanding the exponential and neglecting all but the first two terms, giving: $\nabla^2 \psi = -\frac{1}{\epsilon_0 \epsilon_r} \left[\sum_i c_i^0 z_i e - \sum_i c_i^0 z_i^2 e^2 \psi / kT \right]$. Since the first summation term is zero to maintain electroneutrality, it follows that $\nabla^2 \psi = \left[\frac{\sum_i c_i^0 z_i^2 e^2 \psi}{\epsilon_0 \epsilon_r kT} \right] \psi = \kappa^2 \psi$, with κ being the

→ *Debye–Hückel parameter*. (∇^2 : Laplace operator, ϵ_0 : → *permittivity of vacuum*, ϵ_r : → *dielectric constant* of the electrolyte solution, c_i^0 : bulk concentrations of all ions i , z_i : charges of the ions i , ψ : electric potential, k : → *Boltzmann constant*, and T : the absolute temperature). See also → *Debye–Hückel theory*.

Refs.: [i] Hunter RJ (2004) *Foundations of colloid science*, 2nd edn. Oxford University Press, Oxford, pp 317; [ii] Bockris J'OM, Reddy AKN (1998) *Modern electrochemistry*, vol. 1. Plenum Press, p 230

FS

Debye–Hückel limiting law — The equation based on the → *Debye–Hückel theory* providing mean activity coefficients f for ions of charge z^+ and z^- at → *ionic strength* I in dilute solutions: $\lg f_{\pm} = 0.5091z^+z^-\sqrt{I}$, when mol and dm^3 units are used.

RH

Debye–Hückel–Onsager equation → *Onsager equation*, → *Debye–Hückel–Onsager theory*

Debye–Hückel–Onsager theory — (→ *Onsager equation*) Plotting the equivalent conductivity Λ^{eq} of solutions of strong electrolytes as a function of the square root of concentration ($c^{1/2}$) gives straight lines according to the → *Kohlrausch law*

$$\Lambda^{\text{eq}} = \Lambda^0 - k\sqrt{c}.$$

As the dependency does not include any specific property of the ion (in particular its chemical identity) but only its charge the explanation of this dependency invokes properties of the ionic cloud around the ion. In a similar approach the Debye–Hückel–Onsager theory attempts to explain the observed relationship of the conductivity on $c^{1/2}$. It takes into account the → *electrophoretic effect* (interactions between ionic clouds of the oppositely moving ions) and the relaxation effect (the displacement of the central ion with respect to the center of the ionic cloud because of the slightly faster field-induced movement of the central ion, → *Debye–Falkenhagen effect*). The obtained equation gives the Kohlrausch constant:

$$k = A + B\Lambda^0$$

with

$$A = \frac{z^2 e F^2}{3\pi\eta} \left(\frac{2}{\epsilon RT} \right)^{1/2}$$

and

$$B = \frac{qz^3 e F}{24\pi\epsilon RT} \left(\frac{2}{\epsilon RT} \right)^{1/2}$$

Debye–Hückel–Onsager theory — Table. Debye–Hückel–Onsager coefficients of 1–1-electrolytes at 298 K

Solvent	A/ ($\text{S cm}^2 \text{ mol}^{-1} / (\text{mol dm}^{-3})^{1/2}$)	B/ ($\text{mol dm}^{-3})^{1/2}$)
Methanol	156.1	0.923
Ethanol	89.7	1.83
Propanone	32.8	1.63
(Acetone)		
Nitromethane	125.1	0.708
Nitrobenzene	44.2	0.776
Water	60.2	0.229

D

with the number of charges per atom z , the elementary charge e of an electron, the viscosity η , and the dielectric constant ϵ , and a constant q depending on the type of electrolyte. For a 1–1-electrolyte $q = 0.586$.

Refs.: [i] Atkins PW (1994) *Physical chemistry*. Oxford University Press, Oxford, p 855; [ii] Bockris J'OM, Reddy AKN (1998) *Modern electrochemistry*, vol. 1. Plenum Press, p 520

RH

Debye–Hückel parameter — The Debye–Hückel parameter κ of an → *electrolyte* solution is calculated as follows: $\kappa = \left(e^2 \sum_i c_i^0 z_i^2 / \epsilon_0 \epsilon_r k T \right)^{1/2}$, where e is the → *elementary electric charge*, c_i^0 are the bulk concentrations of all ions i , z_i are the charges of the ions, ϵ_0 is the → *permittivity of vacuum*, ϵ_r is the → *dielectric constant* of the electrolyte solution, k is the → *Boltzmann constant*, and T is the absolute temperature. The Debye–Hückel parameter follows from the → *Debye–Hückel approximation*. The reciprocal value κ^{-1} is the → *Debye length*. See also → *DLVO theory*.

Refs.: [i] Hunter RJ (2004) *Foundations of colloid science*, 2nd ed. Oxford University Press, Oxford, pp 320; [ii] Bockris J'OM, Reddy AKN (1998) *Modern electrochemistry*, vol. 1. Plenum Press, p 230

FS

Debye–Hückel theory — The interactions between the ions inside an electrolyte solution result in a non-ideal behavior as described with the concepts of mixed-phase thermodynamics. Assuming only electrostatic (i.e., coulombic) interactions → *Debye* and → *Hückel* suggested a model describing these interactions resulting in → *activity coefficients* γ suitable for further thermodynamic considerations. Their model is based on several simplifications:

- The dielectric constant of the pure solvent is used; changes caused by the presence of dissolved ions are not taken into account.

- Ions are assumed to be of spherical symmetry, not polarizable and to generate a spherical electrical field around them.
- The electrostatic interaction is assumed to be small in comparison with the energy of thermal movement.
- Strong electrolytes are assumed to be completely dissociated.

The mean ionic activity coefficient is

$$\ln \gamma_{\pm} = \frac{|z_+ z_-| F^2}{8\pi\epsilon N_A R T r_D}$$

with the number of charges z on the ions, the \rightarrow dielectric constant ϵ , Avogadro constant N_A , the \rightarrow gas constant R , the temperature T (in K), and the \rightarrow Debye length r_D . At room temperature with water as solvent and at concentrations below 0.01 mol L^{-1} for 1-1 electrolytes and 0.001 mol L^{-1} for solutions of polyvalent electrolytes the mean activity coefficient is $\lg f_{\pm} = 0.5091 z^+ z^- \sqrt{I}$ with the \rightarrow ionic strength I and z^+ ; z^- the charge number of the involved ions. This relationship is also called \rightarrow Debye-Hückel limiting law.

Refs.: [i] Debye P, Hückel E (1923) *Phys Z* 24:185; [ii] Bockris JO'M, Reddy AKN (2006) *Modern electrochemistry*. Springer, New York

RH

Debye relaxation time — A stationary ion is surrounded by an equally stationary ionic cloud; only thermal movement causes any change in the actual position of a participating ion. Upon application of an external electric field the ions will move. At sufficiently high frequencies f of an AC field ($1/f < \tau$) the symmetry cannot be maintained anymore. The characteristic relaxation time τ is called Debye relaxation time, the effect is also called \rightarrow Debye-Falkenhagen effect. In the absence of a complete and perfectly shaped ionic cloud movement of the ions is less impeded by the ionic cloud, thus electrolytic conductivity should increase. Above frequencies $f \sim 10^7$ to 10^8 s^{-1} this increase has been observed, accordingly the Debye relaxation time is $\tau \sim 10^{-8} \text{ s}$.

Ref.: [i] Bockris JO'M, Reddy AKN (2006) *Modern electrochemistry*. Springer, New York

RH

Decamethylferrocene — A \rightarrow ferrocene derivative with 10 methyl substituents symmetrically replacing hydrogen (permethylferrocene). Decamethylferrocene [i] and decamethylferricenium salts [ii] are readily synthesized.

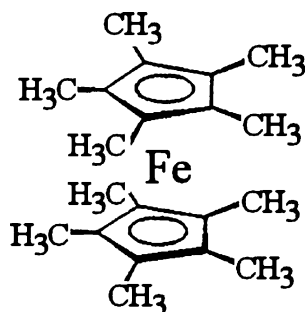

Decamethylferrocene — Figure

Decamethylferrocene undergoes facile oxidation to decamethylferricenium (Cp_2^*Fe) which is (in contrast to ferrocene) chemically highly stable towards hydrolysis. The 10 methyl groups sterically shield the metal center against nucleophilic attack. Due to the electron-donating nature of the methyl groups the reversible oxidation potential of decamethylferrocene is shifted negative to $-0.45 \text{ V vs. Fc}^{+/0}$ in acetonitrile. Solubility: highly soluble in most organic media. Decamethylferrocene is a popular redox system often employed as a model system or in studies of ion transfer between two immiscible electrolyte solutions (\rightarrow droplets, electrochemistry of immobilized \sim). Decamethylferrocene has been proposed as an alternative internal potential calibration system in organic media [iii, iv].

Refs.: [i] King Bisnette MB (1967) *J Organomet Chem* 8:287; [ii] Dugan DM, Hendrickson DN (1975) *Inorg Chem* 14:955; [iii] Noviandri I, Brown KN, Fleming DS, Gulyas PT, Lay PA, Masters AF, Phillips L (1999) *J Phys Chem B* 103:6713; [iv] Matsumoto M, Swaddle TW (2004) *Inorg Chem* 43:2724

FM

Decay constant — The reciprocal value of \rightarrow time constant. See also \rightarrow exponential decay.

FS

Decomposition potential (voltage) — The onset voltage for electrochemical decomposition of the electrolytic solution or the electrodes. The decomposition can take place due to either oxidation or reduction, or both. The decomposition potentials define the \rightarrow electrochemical window of the system. Its value depends on the salt, solvent, electrode material, temperature, and the existence of materials that can catalyze decomposition reactions, such as Lewis acids. Exact decomposition voltages are hard to reproduce as the onset current of the process is very sensitive to the experimental conditions (e.g., scan rate, temperature, type of electrode, etc.). Decomposi-

tion potentials are usually quite subjectively determined by \rightarrow *cyclic voltammetry* as the potential at which \rightarrow *electrolysis* currents begin to increase rapidly, in excess of the \rightarrow *background currents*. Obviously, in such experiment the determined decomposition potentials are sensitive to the kinetics of the electrode processes, and thus the value of \rightarrow *current density* that sets the limits has to be predefined (usually in an arbitrary manner or based on subjective tolerable decomposition currents). These potentials mark the limits of the stability window for the measured system. The decomposition voltages are to be avoided in case that the decomposition reactions alters the measurement or the production of a desired product. In some cases, like in the splitting of water and in the \rightarrow *chlor-alkali production*, it defines the working conditions. In such cases the decomposition potential is the minimum voltage necessary to carry out the reaction, and in such cases it may be even thermodynamically defined.

Refs.: [i] Aurbach D, Gofer Y (1999) *Electrochemical window of electrolyte solutions*. In: Aurbach D (ed) *Nonaqueous electrochemistry*. Marcel Dekker, New York, pp 137–212; [ii] Hamann C, Hamnett A, Vielstich W (1998) *Electrochemistry*. Wiley-VCH, Weinheim, pp 4–6; [iii] Maier J (2004) *Physical chemistry of ionic materials: Ions and electrons in solids*. Wiley, Chichester, p 281

YG

Deconvolution — This operation, as its name implies, means “undoing” a \rightarrow *convolution*. If a function, say $M(t)$, results from convolving the functions $I(t)$ and $g(t)$, $M(t) = I(t) * g(t)$, then $I(t)$ may be regenerated from $M(t)$ by convolution with another function $h(t)$ such that $h(t) * g(t) = 1$. Thus deconvolution is simply convolution with $h(t)$, the complementary function of $g(t)$. The term “deconvolution” is often used in electrochemistry as a synonym for \rightarrow *semidifferentiation*. The motive is to convert an expression proportional to a concentration difference to an expression proportional to current.

Refs.: [i] Imbeaux JC, Saveant JM (1973) *J Electroanal Chem* 44:196; [ii] www.codecon.co.uk

KBO

Decoupling of AC and DC signals — An electrical voltage measured between two points showing a fixed polarity is called a \rightarrow *DC* voltage. Voltages showing changes of polarity as a function of time, both in a fixed or in a variable rhythm (frequency) are called \rightarrow *AC* voltages. A voltage displaying a change in magnitude as a function of time without a change of polarity is called a variable or fluctuating or modulated DC voltage. The lat-

ter case is frequently encountered in electrochemical investigations. In particular, in AC-methods (like e.g., \rightarrow *impedance* measurements, \rightarrow *faradaic rectification*) and in the \rightarrow *electrochemical quartz microbalance* the potential of an electrode is subject to changes best described in electrical terms by the last type of voltage. This voltage can be composed most easily by adding a DC voltage (which finally might be equivalent to the desired operating potential of the investigated working electrode) and an AC voltage of the necessary type (sine wave, noise etc.). The current flowing across the solution/electrode interface will be also of the latter type, consequently it is composed of a DC fraction (equivalent to the DC-current caused by the applied DC-electrode potential) and the AC response. Further signal processing is much easier and can be performed with much better precision when AC- and DC-components are separated. This can be accomplished most easily by inserting a sufficiently large capacitor in the signal line. Any DC-voltage will be blocked, whereas the AC signal will pass the capacitor only slightly diminished depending on the capacity of the capacitor. This attenuation is caused by the frequency-dependent impedance (capacitive resistance) of a capacitor. Thus for the passage of low frequencies larger capacitors are needed.

Ref.: [i] Malmstadt HV, Enke CG (1963) *Electronics for scientists*. Benjamin, New York

RH

Deep discharge — In the batteries world, operation of a \rightarrow *battery* under deep discharge conditions means that at least 80% of the rated capacity of the battery (\rightarrow *depth of discharge* (DOD)) is discharged during cycling. Operation under deep discharge conditions usually limits the \rightarrow *cycle life* of the battery. The reduction in the cycle life is strongly dependent on the rates used for discharging. In addition, when using a stacking battery pack it is extremely important to limit deep discharge to prevent reverse charge from a cell within the pack that becomes fully discharged. Therefore, in normal operation of a battery deep discharge should be avoided. The common way to limit the depth of discharge is by the selection of an appropriate cut-off voltage. Using *cut-off* voltage as a restrictive parameter is limited when very low C rates are used. In the case of \rightarrow *Ni–Cd cells*, deep-discharge cycles should be done occasionally in order to avoid the memory effect of the battery. Batteries are especially designed for applications requiring deep discharge operation. Usually, excess of active material is used to compensate for the losses due to deep discharge. In the case of \rightarrow *lead–acid batteries* (see also \rightarrow *accumulator*), an-

timony is added to the Pb plates in order to allow for thicker plates.

Refs.: [i] Linden D (1994) *Handbook of batteries*, 2nd edn. McGraw-Hill, New York, Appendix A; [ii] Rand DA, Moseley PT, Garche J, Parker CD (2004) *Valve regulated lead-acid batteries*. Elsevier, New York, p 128–150, 229–240

D

Defects in solids — are, in a general sense, imperfections with respect to the ideal crystal structure. **Point defects** involve only one atom or site. These include → *vacancies* (vacant sites), interstitials (→ *ions* or atoms placed between regular sites of a crystal lattice), and the particles placed in crystallographic sites which should be ideally occupied by another component of the lattice. When a → *solid material* contains impurities dissolved in the lattice or when the composition is moderately modified by → *doping*, the admixed ions or atoms are also considered as point defects. The point defects may associate forming clusters; these are classified as a separate group of defects or as extended defects, depending on their size. As a rule, clustering leads to decreasing total effective → *charge*, thus reducing local stresses in the lattice. The cluster growth may result in the formation of microdomains, local structure of which is different with respect to the structure of crystal (partial ordering of defects). The → *electronic defects* are also classified sometimes as point defects, especially if the electronic → *charge carriers* are localized.

A variety of defect formation mechanisms (lattice disorder) are known. Classical cases include the → *Schottky* and → *Frenkel* mechanisms. For the Schottky defects, an anion vacancy and a cation vacancy are formed in an ionic crystal due to replacing two atoms at the surface. The Frenkel defect involves one atom displaced from its lattice site into an interstitial position, which is normally empty. The Schottky and Frenkel defects are both stoichiometric, i.e., can be formed without a change in the crystal composition. The structural disorder, characteristic of → *superionics* (fast → *ion conductors*), relates to crystals where the stoichiometric number of mobile ions is significantly lower than the number of positions available for these ions. Examples of structurally disordered solids are → *β-alumina*, → *NASICON*, and *δ*-phase of → *bismuth oxide*. The antistructural disorder, typical for → *intermetallic* and essentially covalent phases, appears due to mixing of atoms between their regular sites. In many cases important for practice, the defects are formed to compensate charge of dopant ions due to the crystal electroneutrality rule (doping-induced disorder) (see also → *electroneutrality condition*).

OC

The **extended defects** are often divided into three groups: linear, plane, and three-dimensional, although this classification is not entirely satisfactory. Key type of the linear defects relates to dislocations (see → *Burger's vector*). The plane defects include, in particular, subgrain-boundaries formed due to a different angular orientation of two parts of essentially the same crystal, antiphase boundaries involving a lateral shift between two parts of essentially the same crystal, stacking faults, and Wadsley defects (random crystallographic shear planes). Notice that → *grain boundaries* in ceramic materials and crystal → *surface* are also often considered among the two-dimensional defects. Furthermore, the grain and subgrain boundaries may be visualized as dislocation networks. Typical examples of the three-dimensional defects are pores, nano-scale phase inclusions, and various domain structures.

The type and concentration of defects in solids determine or, at least, affect the transport properties. For instance, the → *ion conductivity* in a crystal bulk is usually proportional to the → *concentration* of → *ionic charge carriers*, namely vacancies or interstitials (see also → *Nernst-Einstein equation*). Clustering of the point defects may impede transport. The concentration and → *mobility* of ionic charge carriers in the vicinity of extended defects may differ from ideal due to space-charge effects (see also → *space charge region*).

Refs.: [i] West AR (1984) *Solid state chemistry and its applications*. Wiley, Chichester; [ii] Kittel C (1996) *Introduction to solid state physics*, 7th edn. Wiley, Chichester; [iii] Rickert H (1982) *Electrochemistry of solids. An introduction*. Springer, Berlin; [iv] Chebotin VN (1982) *Physical chemistry of solids*. Khimiya, Moscow

VK

Deflection → *refraction* and → *beam deflection*

Degreasing — Degreasing is a typical pretreatment step which is applied prior to → *electroplating*. The mechanical pretreatment steps (machining, grinding, polishing, etc.) may have left some contaminations on the substrate surface which must be removed prior to the → *electrodeposition* process to ensure uniform coverage and good adherence of the deposit. Usually degreasing is a two-step process consisting of a coarse degreasing and a fine degreasing. The latter is also called electrochemical degreasing. Coarse degreasing is done using organic solvents (e.g., trichloroethylene) or hot alkaline solutions (alkali phosphates, alkali silicates). Substrates with complex geometry can be manually degreased by polishing with a suspension of “Wiener Kalk” (Vienna lime) in water. In the electrochemical degreasing step the action of

an alkaline cleaner (saponification) is combined with the mechanical action of the evolving gas bubbles (oxygen or hydrogen) which tear away the last traces of contaminants. Cathodic degreasing has the advantage of producing twice the amount of gas but hydrogen \rightarrow *embrittlement* or (re)deposition of cationic contaminants may be a problem.

Ref.: [i] Snyder DD (2000) *Preparation for deposition*. In: Schlesinger M, Paunovic M (eds) *Modern electroplating*, 4th edn. Wiley, New York, pp 739–748

AB

Degree of titration — The ratio between the added amount of \rightarrow *titrant* (n_{Titrant}) and the amount of titrant necessary to reach the \rightarrow *equivalence point* (n_{Titrant}^0). Commonly, the amount of titrant is expressed in moles and the titration degree (τ) is given by the following equation: $\tau = \frac{n_{\text{Titrant}}}{n_{\text{Titrant}}^0}$ [i].

Ref.: [i] Harris D (2002) *Quantitative chemical analysis*. WH Freeman, New York

FG

Deionization \rightarrow *desalination*

De La Rive, Auguste-Arthur



(Courtesy of Institute and Museum of the History of Science, Florence)

(Oct. 9, 1801, Geneva, Switzerland – Nov. 27, 1873, Marseille, France) De La Rive was physicist who studied electricity and magnetism, working in England, France, and Switzerland on the theory and practical applications of electricity [i]. He was one of the founders of the electrochemical theory of \rightarrow *batteries*. He studied electricity passing through gases, and demonstrated that ozone is formed by electrical sparks in oxygen. To explain the rotatory movements of the aurorae boreales by the influence of the terrestrial magnetism, De La Rive designed an egg-shaped evacuated glass chamber assembled on an electromagnet. A Ruhmkorff coil powered an electric discharge in a rarefied gas demonstrating the rotatory effect of a magnetic field on the discharge process.

De La Rive invented a new \rightarrow *electroplating* method to deposit gold onto brass and silver, and designed one of the first incandescent lamps using a platinum filament in a partially evacuated glass tube. He also designed an electrochemical \rightarrow *capacitor* (condenser), 1843.

Ref.: [i] De La Rive AA (1853–1858) *A treatise on electricity: In theory and practice*. Longman Brown Green & Longmans, London

EK

Delaurier cell — This was a chromic acid (carbon electrode)–zinc \rightarrow *battery* with a chromic acid electrolyte that contained additionally iron(III) sulfate. See also \rightarrow *chromic acid battery*, \rightarrow *Daniell cell*, \rightarrow *zinc*, \rightarrow *Zn²⁺/Zn electrodes*, \rightarrow *Zn²⁺/Zn(Hg) electrodes*, \rightarrow *zinc–air batteries (cell)*, and \rightarrow *Leclanché cell*.

Ref.: [i] Hauck WP (1883) *Die Galvanischen Batterien, Accumulatoren und Thermosäulen*, 2nd edn. Hartleben's Verlag, Wien

FS

Delayed PBD (probe beam deflection) response — An outcome related to the difference on time between the \rightarrow *current* response of a reaction that is measured at the electrode surface and its corresponding deflection signal measured at some micrometers from the surface. It is an effect associated with the time required for the \rightarrow *diffusion* and \rightarrow *migration* of soluble species between the electrode surface and the position in which the signal of \rightarrow *probe beam deflection* is measured [i]. This effect is also termed propagation delay or diffusional delay.

Ref.: [i] Barbero CA (2005) *Phys Chem Chem Phys* 7:1885; [ii] Garay F, Barbero CA (2006) *Anal Chem* 78:6740

FG

Delocalization — A quantum mechanical concept most usually applied in organic chemistry to describe the π -bonding in a conjugated system. This bonding is not localized between two atoms: instead, each link has a “fractional double bond character” or \rightarrow *bond order*. There is a corresponding “delocalization energy”, identifiable with the stabilization of the system compared with a hypothetical alternative in which formal (localized) single and double bonds are present. Some degree of delocalization is always present and can be estimated by quantum mechanical calculations. The effects are particularly evident in aromatic systems and in symmetrical \rightarrow *molecular entities* in which a lone pair of electrons or a vacant p-orbital is conjugated with a double bond (e.g., carboxylate ions, nitro compounds, enamines, the allyl cation). Delocalization in such species may be represented by partial bonds or as resonance (here symbolized by a two-headed arrow) between contributing structures.

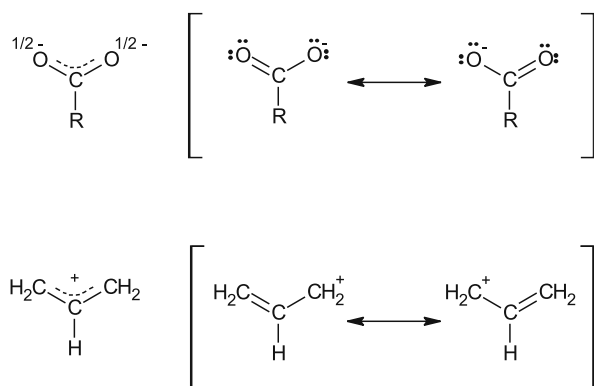

Delocalization — Figure

These examples also illustrate the concomitant delocalization of charge in ionic conjugated systems, like π -conjugated \rightarrow *conducting polymers*. Electrode surfaces are modified with films of π -conjugated conducting polymers to form \rightarrow *polymer-modified electrodes*. Analogously, delocalization of the spin of an unpaired electron occurs in conjugated \rightarrow *radicals*.

Ref.: [i] Muller P (1994) *Pure Appl Chem* 66:1077

WK

Demineralization \rightarrow desalination

Dendrite growth (electrodeposition) — Electrochemical deposition (\rightarrow *electrodeposition*) of matter by, e.g., reduction of metal ions or oxidation of aniline yields deposits on the electrode where the reaction occurs. In the case of metal deposition various modes of growth have been identified: Formation of many nuclei growing both in diameter and height (spontaneous nucleation, three-dimensional growth, \rightarrow *Volmer-Weber growth*), layer-by-layer growth (two-dimensional growth, \rightarrow *Frank-van der Merwe growth*) and growth of numerous nuclei on a complete layer of the deposited metal (\rightarrow *Stranski-Krastanov growth*). Rapid increase of height by growth of a nucleus away from the electrode surface may result in the formation of dendrites (needle-shaped deposits). They may penetrate separators in secondary \rightarrow *batteries* causing internal short circuiting, they will cause rough surfaces in electroplating.

RH

Density gradient — Change of density $\partial\rho$ as a function of location ∂x . A density gradient is, e.g., observed in front of an electrode where metal deposition by reduction of metal ions from solution is proceeding. The removal of ions from solution causes a decrease in ionic

concentration and in most cases (especially with heavy ions) a change in density. Closely related to the \rightarrow *concentration gradient* established during this process a density gradient is established. In an otherwise stagnant electrolyte solution this gradient might cause free \rightarrow *convection*. Generally convection is the fundamental reason of the establishment of a finite \rightarrow *diffusion layer thickness*.

RH

Density of states (semiconductor-solution interface)

Density of states is the number of allowed energetic states in a solid. It is a property in statistical and condensed matter physics that quantifies how closely packed energy levels are in a physical system. It is often expressed as a function $g(E)$ of the internal energy E , or a function $g(k)$ of the wave vector k . Most frequently density of states is used with electronic energy levels in a solid (\rightarrow *metals* and \rightarrow *semiconductors*). Typical values of the density of states in the conduction band of germanium are 1.04×10^{19} , in the valence band 6×10^{18} . With InP the respective values are 5.8×10^{17} and 1.4×10^{19} .

Ref.: [i] Memming R (2002) *Semiconductor electrochemistry*. Wiley-VCH, Weinheim

RH

Depletion region — A depletion region is any part of a \rightarrow *semiconductor* device that has been depleted of majority carriers due to the presence of an \rightarrow *electric field*, so that it becomes nearly insulating. The electric field may arise from an externally applied bias, the presence of a nearby \rightarrow *interface* composed of a differently doped semiconductor material (as in a p-n junction), or the presence of a nearby interface composed of a metal (as in a \rightarrow *Schottky barrier*). In the presence of light, photons may interact with matter inside a depletion region, creating electron-hole pairs that are then rapidly separated by the electric field. Efficient separation permits the electrons and holes to do useful work in an external circuit. This is the basis of many photoelectrochemical (\rightarrow *photoelectrochemistry*) devices. The differential capacity C_{SC} of the depletion region (also called the space-charge region) in a semiconductor is related to the potential drop $\Delta\varphi_{SC}$ across it by the Mott-Schottky equation (\rightarrow *Mott-Schottky plot*).

SF

Depolarization — The partial or complete elimination or counteraction of \rightarrow *polarization* of an \rightarrow *electrode* during electrochemical processes by adding a \rightarrow *depolarizer*. The term refers to a situation where the electrode

potential is the measured (dependent) quantity and the current is the controlled (given) quantity. Since in many electrochemical experiments the situation is vice versa, i.e., the current is the measured (dependent) quantity and the potential is controlled (given), the term 'depolarization' is used – not completely correct in the sense of the word – for processes that cause the current to flow, i.e., by → *faradaic reactions*.

BM

Depolarizer — A compound that is capable of reducing or eliminating the → *polarization* of an electrode when a → *current* is applied, i.e., a compound that causes → *depolarization*. The term is used for any compound that is oxidized or reduced on an electrode, independent of the experimental setup, i.e., for experiments with controlled currents and also controlled potentials.

BM

Deposition — A process in which a compound or material is deposited on an electrode surface using electrolysis. Deposition processes play an important role in many technologies (e.g., coating of materials with metals or oxides, → *electrodeposition*) and in analytical methods (→ *electrogravimetry*, → *stripping voltammetry*).

BM

Deposition overpotential → *potential*, and → *overpotential*

Deposition potential → *potential*, subentry → *deposition potential*

Depth of discharge — (DOD) is defined as the percentage of the rated → *capacity* that is drawn off during each discharge step. DOD is expressed in percentage (%) from the rated maximum capacity of the → *battery*. The depth of discharge is one of the dominant parameters that determine the cycle life of a rechargeable battery. If a long → *cycle life* is desired, the battery should be operated at low DOD or low rates.

Refs.: [i] Linden D (1994) *Handbook of batteries*, 2nd edn. McGraw-Hill, New York, Appendix A; [ii] Anil Ahuja (1997) *Integrated M/E design: Building systems integration*. Springer, New York, p 116

OC

Derjaguin–Landau–Verwey–Overbeek theory
→ *DLVO theory*

Desalination — is a process to produce clean (potable) water from brackish or seawater. This is done mainly by

thermal evaporation, but also by several membrane separation processes, including reverse → *osmosis*, → *electrodialysis*, or membrane distillation.

Industrially most significant is the d. by reverse → *osmosis*. It is used especially in d. plants with lower capacities, as e.g., on passenger (cruise) and war ships. The design of a typical plant comprises either a spiral-wound or hollow fiber membrane module design. Either composite membranes or asymmetric phase inversion membranes made of polyamide are used. The incoming feed water must be prefiltered and chemically treated, in order to avoid membrane fouling and scaling. It is fed by a high-pressure pump into the membrane modules, operated in parallel or in series. A portion of the feed stream permeates the membrane and is recovered as product water. The retentate becomes increasingly concentrated and leaves the membrane modules at a pressure ca. 10–15% lower than at the inlet. Typical product recovery rates in seawater desalination plants are ca. 50%, depending on the feed water composition, membrane properties, product water quality requirements, and plant operating conditions. The approximate required energy for the desalination of sea- or brackish water is 1–4 kWh per cubic meter of product water, depending on the above-mentioned factors. Total process costs for reverse osmosis water d. amount to ca. 0.7–3 US \$ per cubic meter of product water, mainly depending on the composition of the feed solution. Reverse osmosis technology, combined with → *ion-exchange* resins, is used in the production of pure and ultrapure water for biomedical and microbiological use, for the semiconductor industry and analytical laboratories.

The second typical technology applied for d. of water is → *electrodialysis*. After appropriate pretreatment (as above), the feed solution is pumped through the unit of one or more stacks in series or parallel. The concentrated and depleted process streams leaving the last stack are recycled, or finally collected in storage tanks. The plants operate unidirectionally, as explained, or in reverse polarity mode, i.e., the current polarity is changed at specific time intervals (minutes to hours), and the hydraulic flow streams are reversed simultaneously, thus preventing the precipitation in the brine cells.

Refs.: [i] El-Dessouky HT, Ettouney HM (2002) *Fundamentals of salt water desalination*. Elsevier; [ii] Rautenbach R (2002) *Membrane separation processes in water treatment*. In: *Ullmann's encyclopedia of industrial chemistry*, 6th edn. Wiley-VCH; [iii] Leitner GF (1989) *Desalination* 76:201

MHer

Desorption — A physical process leading to separation of substances. Desorption is a process opposite to \rightarrow *adsorption*. In this phenomenon sorbed substance is released from the adsorbing surface to bulk of solution or to the gas phase. Desorption can be accomplished by disturbing the equilibrium of adsorption, and by diminishing the concentration of adsorbed substance in the surrounding phase. Also changes in physical conditions of the system, like decreasing of pressure or increasing of temperature may trigger a desorption. In electrochemistry desorption of substances from the surface of an \rightarrow *electrode* can be induced by changing the \rightarrow *electrode potential*. Desorption phenomena usually strongly affect the \rightarrow *double layer structure* and change its \rightarrow *capacitance* as seen in voltammetric experiments.

Ref.: Atkins PW (1998) *Physical chemistry*, 6th edn. Oxford University Press, Oxford

MD

Despić, Aleksandar



(Reproduced with permission of the Institute of Electrochemistry, Belgrade, Serbia)

(Jan. 6, 1927, Belgrade, Serbia – Apr. 7, 2005, Belgrade, Serbia) Despić studied chemistry at Belgrade University (B.Sc. in 1951) and the Imperial College, London, UK (Ph.D. in 1955). He specialized in electrochemistry at the University of Pennsylvania, Philadelphia, USA (1957–1959) and was visiting professor at that University in 1969 [i]. He worked at the Faculty of Technology of Belgrade University since 1953, from 1971 as a full professor. Despić was a corresponding member (1965–1976) and full member (since 1976) of the Serbian Academy of Sciences and Arts, in which institution he served as vice-president (1981–1994) and president (1995–1999). He was also president (1973–1977) and honorary president (since 1978) of the Serbian Chemical Society, and vice-president of the International Society of Electrochemistry (1977–1979). Despić wrote about 170 scientific and 40 professional papers, 14 book chapters, and he received

27 patents in the fields of electrodeposition and dissolution of metals, electrode reaction mechanisms and kinetics, corrosion, catalytic reactions, power sources, and solar energy [ii].

Refs: [i] Bockris JO'M (2005) *J Serb Chem Soc* 70:789; [ii] Despić AR (1983) *Deposition and dissolution of metals and alloys, Part B: mechanism, kinetics, texture and morphology*. In: Bockris JO'M, Conway BE, Yeager E (eds) *Comprehensive treatise of electrochemistry*, vol. 7, Plenum Press, New York

MLo

Detectors — Detectors are instruments to detect the presence of a substance and to measure its concentration (or amount). Electrochemical detectors can be based on \rightarrow *potentiometry*, \rightarrow *conductometry*, \rightarrow *amperometry*, \rightarrow *voltammetry*, \rightarrow *impedance spectroscopy*, \rightarrow *oscillometry*, \rightarrow *coulometry*, or any other signal-generating technique. Most detectors are applied to measure under flow-through conditions, e.g., in chromatography, flow-injection analysis, gas analysis. Among the potentiometric detectors, the \rightarrow *lambda probe* outnumbers all other detectors because of its use in controlling the combustion process in car engines. As amperometric detectors \rightarrow *ultramicroelectrodes* are used because they allow measurements at low electrolyte concentrations. Electrochemical gas detectors (\rightarrow *gas detectors*) have been developed also for the security surveillance of workplaces, etc.

Refs.: [i] Ryan TH (ed) (1984) *Electrochemical detectors. Fundamental aspects and analytical applications*. Plenum Press New York; [ii] Váňa J (1982) *Gas and liquid analyzers*. In: Svehla G (ed) *Wilson and Wilson's comprehensive analytical chemistry*, vol. XVII. Elsevier, Amsterdam; [iii] Mount AR (2003) *Hydrodynamic electrodes*. In: Bard AJ, Stratmann M, Unwin P (eds) *Instrumentation and electroanalytical chemistry. Encyclopedia of electrochemistry*, vol. 3. Wiley-VCH, Weinheim, pp 134

FS

Detection limit \rightarrow *limit of detection*

Deutonium (D_3O^+) activity \rightarrow *glass electrode*

DHE \rightarrow *dynamic hydrogen electrode*

Diabatic process \rightarrow *Nonadiabatic (diabatic) process*

Diamond electrode — Electrode made from \rightarrow *boron-doped diamond* or similar doped diamond materials. Diamond, natural or synthetic, exhibits some exceptional material properties such as low thermal expansion, optical transparency for visible, IR, and microwave radiation, mechanical strength, and shock resistance [i].

Boron-doped diamond is electrically conducting and has found applications as electrode material in wastewater treatment, ozone generation, electroanalysis, and trace metal detection [ii]. Due to their exceptional chemical inertness and mechanical strength, diamond electrodes have been proposed for applications in extremely aggressive media such as strong acids or plasmas. See also → *carbon electrodes*.

Refs.: [i] Wilks E, Wilks J (1991) *Properties and applications of diamond*. Butterworth-Heinemann, Oxford; [ii] Swain GM, Anderson AB, Angus JC (1998) *MRS Bull* 23:56

FM

Diaphragm — Device separating electrochemical → *half-cells*, but providing the necessary → *ionic conductivity*, while preventing free mixing of the → *electrolytes*. Diaphragms and → *membranes* are used to separate the electrolyte solution surrounding the → *working electrode* from the electrolyte solutions of the → *auxiliary* and → *reference electrodes*. This is needed because the products that are formed at the auxiliary electrode should not interfere with those produced by the reaction on the working electrode. Diaphragms are particularly important in → *electrolysis* cells and especially in → *coulometry*. In experiments using a reference electrode, that electrode must be separated from the cell because its potential depends on the composition and the concentration of the electrolyte that surrounds it. The compartments can be separated using diaphragms of sintered glass or porous, permeable glass (→ *Vycor*®), ceramic materials and porcelain, agar gel, or → *ion exchange membranes*. Some examples of → *anolyte* and → *catholyte* separators used in the industry are steel net-supported asbestos diaphragms and ion-selective polymer membranes in the chlor-alkali production and water electrolysis. Good separators must be chemically inert and mechanically durable. However, because of → *ohmic resistance*, they are avoided wherever it is possible.

See also → *separator* and → *electroosmosis*.

Ref.: [i] Pletcher D, Walsh FC (1993) *Industrial electrochemistry*. Blackie Academic & Professional, London

SKL

Diaphragm process → *alkali chloride electrolysis*

Dichloromethane — Organic solvent (CH_2Cl_2 , methylene chloride, melting point -94.9°C , boiling point 39.6°C) with a density (1.325 g cm^{-3} at 25°C) heavier than water and essentially immiscible with water. Due to its inert properties and good → *solvation* power for

organic molecules (→ *dielectric constant* $\epsilon_r = 8.93$), dichloromethane is often used as a solvent for organo-electrochemical processes with a suitable electrolyte salt such as tetrabutylammonium hexafluorophosphate. Dichloromethane is readily purified by passing over active basic alumina or P_4O_{10} [i].

Ref.: [i] Reichardt C (2003) *Solvents and solvent effects in organic chemistry*. Wiley-VCH, Weinheim

FM

Dielectric — A material in which a → *DC* field does not produce a *DC* → *current* flow is called a dielectric, or insulator.

Ref.: Elliott SR (1998) *The physics and chemistry of solids*. Wiley, Chichester

FS

Dielectric constant — Symbol: ϵ_r (dimensionless).

Relative → *permittivity* of a dielectric (an electronic → *insulator*) or relative dielectric constant or, shorter, dielectric constant ϵ_r is the proportionality constant between the electric field strength and the charge density for a plate condenser with a dielectric medium between the two plates. In case of vacuum this constant is called the permittivity of free space ϵ_0 and its value is $8.85418782 \times 10^{-12}\text{ C V}^{-1}\text{ m}^{-1}$. When a dielectric is present between the two plates, an increase of the charge density is observed compared to the case with a vacuum. This relative increase is called the relative dielectric constant ϵ_r , i.e., it is unity for vacuum. The dielectric constant can be determined from the capacity of a condenser with the dielectric to be studied between the plates. The electric susceptibility of the dielectric is defined as: $\chi_e = \epsilon_r - 1$.

Ref.: [i] Kuhn H, Försterling HD (1999) *Principles of physical chemistry*. Wiley, Chichester, p 27

MLo

Dielectric relaxation — Dielectric materials have the ability to store energy when an external electric field is applied (see → *dielectric constant*, *dielectric* → *permittivity*). Dielectric relaxation is the delayed response of a dielectric medium to an external field, e.g., AC sinusoidal voltage, usually at high frequencies. The resulting current is made up of a charging current and a loss current. The relaxation can be described as a frequency-dependent permittivity. The real part of the complex permittivity (ϵ') is a measure of how much energy from an external electric field is stored in a material, the imaginary part (ϵ'') is called the loss factor. The latter is the measure of how dissipative a material is to an exter-

nal electric field. A material may have several dielectric mechanisms or polarization effects that contribute to its overall permittivity. Each dielectric mechanism effect has a characteristic resonant frequency or relaxation frequency.

Materials that exhibit a single relaxation time constant can be modeled by the Debye relation which appears as a characteristic response in the permittivity as a function of frequency. The complex permittivity diagram is called Cole–Cole diagram constructed by plotting ϵ'' vs. ϵ' with frequency as independent parameter.

The dielectric relaxation plays an important role in electrochemistry. For instance, the solvent dipoles, e.g., water molecules, have a smaller relaxation time (in MHz range) when bonded to an ion in the hydration sphere or to a charged surface in comparison with the free water molecules the characteristic relaxation time of which falls in the GHz range. The Bockris–Devanathan–Müller theory takes this effect into account in modeling the \rightarrow double layer. The ionic \rightarrow conductivity only introduces losses into a material. Interfacial or space-charge polarization occurs when the motion of migrating species is impeded. The charges can become trapped within the interface of a material. Motion may also be impeded when charges cannot be freely discharged or replaced at the electrode. The field distortion caused by the accumulation of these charges increase the overall capacitance of a material which appears as an increase in ϵ' . When electrically conducting regions are separated by nonconducting regions ϵ' decreases as a function of frequency since at high frequencies the charges have no time to accumulate at the surfaces of the borders (Maxwell–Wagner effect). Dielectric relaxation in an electrochemical environment [iv] can be caused by the \rightarrow electrolyte [v], by surface layers, or by the \rightarrow double layer. Characteristic for dielectric relaxation is the frequency-dependent \rightarrow impedance according to

$$\frac{d \log Z}{d \log t} > -1$$

or an almost constant phase angle $> -90^\circ$ (\rightarrow constant phase element). In the time domain, after a potential step, the \rightarrow current density relaxes according to

$$i \propto t^{-1} \text{ or } \frac{d \log i}{d \log t} = -1$$

(Curie–von Schweidler law). Such behavior is simulated by a number of combinations of capacitors and resistors with overlapping time constants. Dielectric relaxation is mainly explained by two models, the dipole

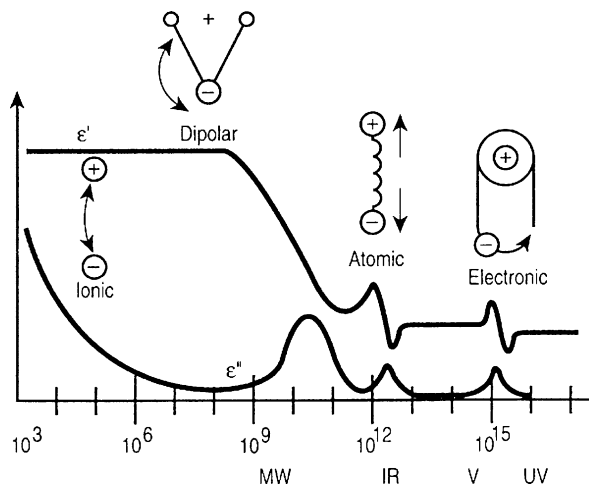

Dielectric relaxation — Figure. The frequency responses (dielectric relaxation) of a material and the related dielectric mechanisms. On the abscissa the frequencies are indicated in Hertz. (from ref [iii])

model and the geometric model. The dipole model assumes a large number of dipoles in the dielectric which are reversibly turned or stretched by an electric field. If the field is lowered, the dipoles relax again. Both processes require a field-supported thermal activation and are therefore delayed. Normally, a flat distribution of activation energies is necessary to describe the experiments [vi]. The geometric model assumes a special shape of a rough or structured electrode surface [vii]. These structures (e.g., a fractal topography [viii] or trenches and pores [ix]) are simulated by special ladder networks of resistances and capacitors which describe the complex interaction of \rightarrow double-layer capacitances and electrolyte or surface film resistances, respectively. Both models must be able to explain the wide range of dielectric relaxation which covers up to ten decades in the time domain. An experimental distinction between the models is not trivial.

Refs.: [i] Geyer RG (1990) *Dielectric characterization and reference materials*. NIST Technical Note, p 1338; [ii] von Hippel A (1961) *Dielectric materials and applications*. MIT Press, Cambridge; [iii] Hewlett-Packard Application Note 1217-1 (1992) *Basics of measuring the dielectric properties of materials*; [iv] Jonscher AK (1983) *Dielectric relaxation in solids*. Chelsea Dielectric Press, London; Ross JR (1987) *Impedance spectroscopy*. Wiley, New York; [v] Buchner R, Barthel J (2001) *Annu Rep Prog Chem C* 97:349; [vi] Dutoit EC, Van Meirhaege RL, Cardon F, Gomes WP (1975) *Ber Bunsenges Phys Chem* 79:1206; [vii] de Levie R, Vogt A (1990) *J Electroanal Chem* 278:25; [viii] Liu SH (1985) *Phys Rev Lett* 55:529; Sapoval B, Chazavil J-N, Peyrière J (1988) *Phys Rev A* 38:5867; [ix] de Levie R (1965) *Electrochim Acta* 10:113

Dielectrophoresis — Defined as the translational motion of an electrically neutral particle caused by polarization (see → *dipole moment*) effects in a nonuniform electric field [i, ii]. The translational force producing this effect arises from the interaction of the particle's dipole moment 'm' (permanent or induced) with the nonuniform electric field. In the figure below, case (a) is shown where the charge relaxation time (see → *dielectric relaxation*) of the particle is less than that of the surrounding fluid. The dipole 'm' induced in the particle, as a result of the build-up of surface free charges, is oriented in such a way that the particle experiences a net force attracting it more towards the anode than the cathode. The particle is thus attracted to the high field region, and this is termed positive dielectrophoresis. Case (b) applies where the charge relaxation time inequality is reversed, and now the particle is pushed away from the anode more strongly than the repulsion from the cathode. The net force acting on the particle pushes it away from the strong field region under the action of negative dielectrophoresis.

In its simplest form the force acting on the particle is given by $F = (m \cdot \nabla)E$ where ∇ is the grad vector operator defining the gradient of the local electric field E . The dipole moment m induced in a particle, of volume v , is given by $m = pvE$ where p is the polarizability factor that determines the relative charge relaxation times of the particle and fluid. From these two equations we can write the translational force as $F = pv(E \cdot \nabla)E = \frac{1}{2}pv\nabla|E|^2$. It follows that the dielectrophoretic force is zero if the field is uniform (i.e., for $\nabla E = 0$), and that the force depends on the → *polarizability* of the particle, the volume of the particle, and the square of the applied electric field magnitude.

The polarizability of a particle is a sensitive function of its physico-chemical properties and structure. This means that particles such as biological cells can be selectively manipulated as a result of their own intrinsic properties, without the need for biochemical labels, beads, dyes, or other markers and tags. The dependence on particle volume indicates that, with all other factors remaining constant, the larger the object the greater will be the dielectrophoretic force acting on it. The dependence on the square of the field emphasizes that the effect is independent of the polarity of the applied field, and can thus be observed using either AC or DC fields. Selective manipulation of a specific particle type in a mixture is best achieved using a radio frequency field at a frequency where the induced charge relaxation properties of the target particle differ significantly from the other particle types. Dielectrophoresis, which can

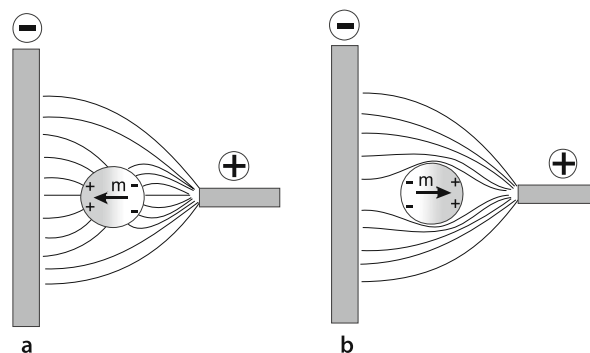

Dielectrophoresis — Figure

operate on uncharged particles in AC fields, thus differs significantly from electrophoresis (see → *electrophoretic effect*) where particles carrying a net charge are induced to move in a uniform DC field. Dielectrophoresis has been exploited for biomedical applications, such as separating stem cells from bone marrow [iii] and for manipulating cells and other bioparticles on lab-on-a-chip devices [iv].

Refs.: [i] Pohl HA (1978) *Dielectrophoresis*. Cambridge University Press, Cambridge; [ii] Jones TB (1995) *Electromechanics of particles*. Cambridge University Press, Cambridge; [iii] Stephens M, Talary M, Pethly R et al (1996) *Bone Marrow Transplant* 18:777; [iv] Voldman J (2006) *Annu Rev Biomed Eng* 8:425

RP

Diffuse double layer → double layer

Difference effect — During anodic dissolution of metals whose → *standard electrode potential* is more negative than that of the → *hydrogen electrode*, hydrogen evolution may proceed as competing process. If the hydrogen evolution is faster when an anodic current is flowing this is called negative difference effect, a decrease of hydrogen evolution is called positive difference effect. The negative difference effect is explained by assuming that anodic current flow and the concomitant metal dissolution removes protective surface layers (scale) on, e.g., magnesium, aluminum, or titanium resulting in enhanced chemical attack of the electrolyte solution and corresponding hydrogen evolution. The origin of the positive difference effect is still under discussion, chemical reaction inhibiting the formation of films is mostly considered.

Refs.: [i] Straumanis ME (1958) *J Electrochem Soc* 105:284; [ii] Straumanis ME, Wang NY (1956) *J Electrochem Soc* 102:304

RH

Differential capacity — An older name for differential capacitance (\rightarrow *double layer*).

ZS

Differential galvanometer — Historic \rightarrow *amperemeter* where a small magnetic needle is placed between two metal coils that can be connected to two current sources. The needle deflection depended on the difference of currents.

Ref.: [i] <http://physics.kenyon.edu/EarlyApparatus/>

FS

Differential potentiometric titration — means the experimental recording of the first derivative of potential over volume of added titrant of a \rightarrow *potentiometric titration* curve. This can be achieved with a \rightarrow *retarded electrode* as developed by \rightarrow *MacInnes*. In a broader sense this term also covers the mathematical derivation of potentiometric titration curves.

FS

Differential pulse polarography \rightarrow *polarography*, subentry \rightarrow *differential pulse polarography*

Differential pulse voltammetry (DPV) — Voltammetric technique (\rightarrow *voltammetry*) in which small voltage pulses are superimposed to a linear varying voltage or to a staircase ramp voltage (see also \rightarrow *differential pulse polarography*). The current is measured shortly before each pulse and before the end of each pulse, and the difference is amplified. DPV is one of the most sensitive voltammetric techniques because the capacitive currents are strongly discriminated and the ratio of \rightarrow *faradaic current* to \rightarrow *charging current* is large. DPV is rather insensitive to electrochemical irreversibility of the electrode process, so that even irreversible systems produce high peak currents.

Refs.: [i] Bard AJ, Faulkner LR (2001) *Electrochemical methods*, 2nd edn. Wiley, New York; [ii] Bond AM (1980) *Modern polarographic methods in analytical chemistry*. Marcel Dekker, New York; [iii] Galus Z (1994) *Fundamentals of electrochemical analysis*, 2nd edn. Ellis Horwood, New York, Polish Scientific Publ PWN, Warsaw; [iv] Stojek Z (2002) *Pulse voltammetry*. In: Scholz F (ed) *Electroanalytical methods*. Springer, Berlin

FS

Differential staircase voltammetry — In this variation of staircase \rightarrow *voltammetry* the current is sampled twice on each tread of the staircase potential–time waveform. The difference between the two currents sampled on the same step is amplified and recorded as a function of the

step potential. The response is a bell-shaped current–potential curve with a maximum that is proportional to the bulk concentration of an analyte [i]. By this procedure, the \rightarrow *background current* can be successfully suppressed [ii]. The theory is described in [iii] and [iv].

Refs.: [i] Scholz F, Nitschke L, Henrion G (1988) *Fresenius Z Anal Chem* 332:805; [ii] Scholz F, Draheim M, Henrion G (1990) *Fresenius J Anal Chem* 336:136; [iii] Lovrić M (1995) *Croat Chem Acta* 68:335; [iv] Yu JS, Zhang ZX (1997) *J Electroanal Chem* 427:7

MLo

Diffraction (X-ray, neutron, or electron diffraction – simultaneous application in electrochemistry) —

A unique method for studying the phase composition and the atomic structure of crystalline materials. \rightarrow *Electrodes* and \rightarrow *solid electrolytes* are usually crystalline materials with a regular atomic structure that predicts their electrochemical behavior. For instance, the ionic transport in solid electrolytes or \rightarrow *insertion electrodes* is possible only owing to the special atomic arrangement in these materials. The method is based on the X-ray (neutron or electron) reflection from the atomic planes. The reflection angle θ depends on the X-ray (neutron or electron) wave length λ and the distance d between the atomic planes (Bragg's Law):

$$2d \sin \theta = n\lambda \text{ (here } n \text{ – integer) .}$$

The positions (angles) and intensities of the reflections in the diffraction patterns are typical (fingerprint) for each compound and can be transformed into the atomic arrangement. The samples for the crystal structure determinations are usually single crystals, but more complex modern methods allow such an analysis for powder materials. The X-ray powder diffraction patterns are widely

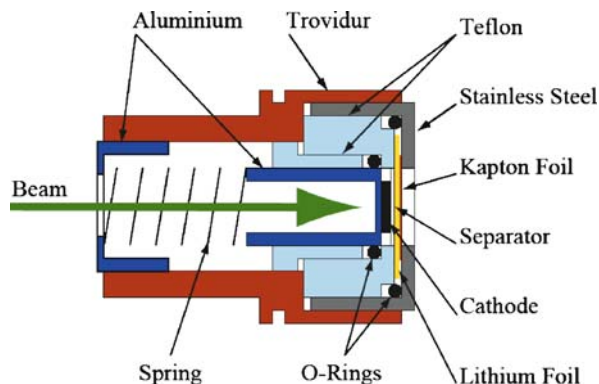

Diffraction (X-ray, neutron, or electron diffraction – simultaneous application in electrochemistry) — Figure 1. A typical cell for *in situ* XRD experiments in transmission mode (Ref. [v])

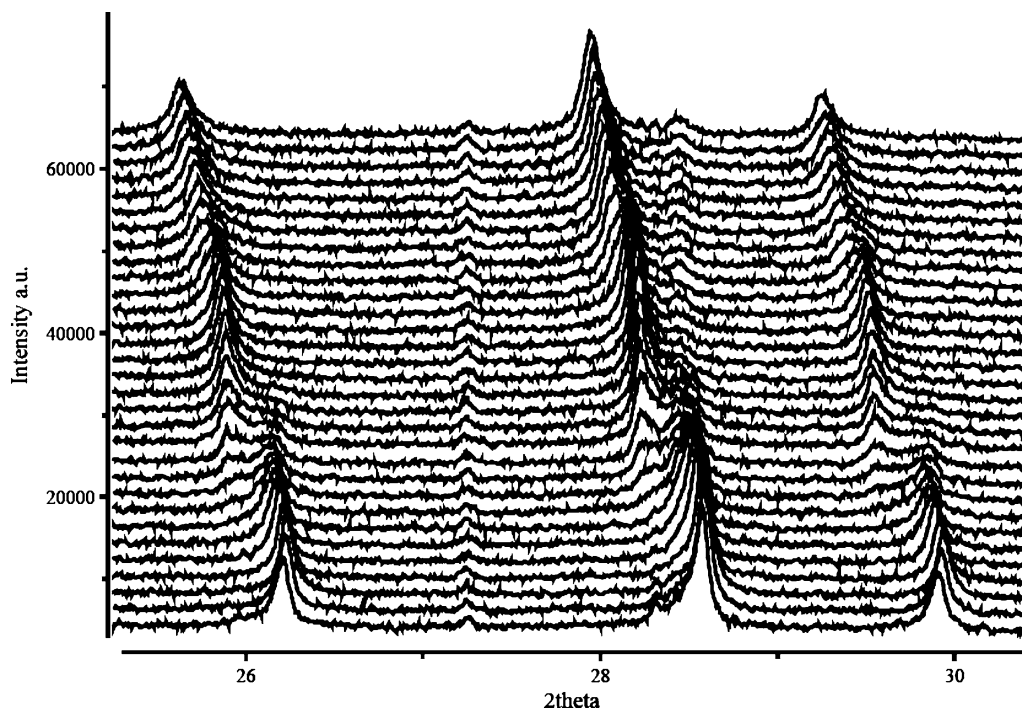

Diffraction (X-ray, neutron, or electron diffraction – simultaneous application in electrochemistry) — Figure 2. The evolution of the XRD patterns of spinel $\text{Li}_x\text{Mn}_2\text{O}_4$: bottom $x = 0$, top $x = 1$ (Ref. [v])

used to identify the type of material in any mixture by comparing them with the standard patterns of the International Powder Diffraction File (PDF) database. For instance, the phase composition of the active electrode mass (such as LiMO_2 , $M = \text{Co}, \text{Ni}, \text{Mn}$) obtained in the synthesis is commonly controlled by XRD.

The phase identification is especially important for insertion electrodes. In this case, the electrochemical curves can be regarded as some kind of phase diagram for the hosts and the insertion ions. Thus, the electrochemical process reflects the \rightarrow *phase transitions* that take place in the host upon ion insertion. The study of this process by phase analysis can be performed for electrodes removed from the solution at the characteristic points of the electrochemical curve (*ex situ* experiments), but it can be also performed simultaneously with electrodes polarized in electrochemical cells, as shown below (*in situ* experiments).

In situ XRD measurements in the cell described herein may be especially useful when the source of the beam is a synchrotron. Such a beam has the necessary intensity for use in the transmittance mode, which is the most convenient for simultaneous XRD and electrochemical measurements.

Refs.: [i] West AR (1988) *Basic solid state chemistry*. Wiley, New York, pp 323; [ii] Nazri GA, Pistoia G (eds) (2004) *Lithium batteries: Science and technology*. Kluwer, Boston, parts I–III; [iii] David WIF, Shankland K, McCusker LB, Baerlocher C (eds) (2002) *Structure determination from powder diffraction data*. Oxford University Press, Oxford, pp 337; [iv] Jenkins R, Snyder RL (1996) *Introduction to X-ray powder diffractometry*. Wiley, New York, pp 403; [v] Baehtz C, Buhrmester T, Bramnik NN, Nikolowski K, Ehrenberg H (2005) *Solid State Ionics* 176:1647

EL, DA

Diffuse layer capacitance — The diffuse layer is the outermost part of the electrical double layer [i]. The electrical \rightarrow *double layer* is the generic name for the spatial distribution of charge (electronic or ionic) in the neighborhood of a phase boundary. Typically, the phase boundary of most interest is an electrode/solution interface, but may also be the surface of a colloid or the interior of a membrane. For simplicity, we here focus on the metal/solution interface. The charge carriers inside the metal are \rightarrow *electrons*, which are confined to the metallic phase. The charge carriers inside the solution are ions, which are confined to the solution phase. Due to the differences in \rightarrow *work function* between the

two phases, the different charge carriers in the different phases accumulate in the vicinity of the interface, in an attempt to maintain overall \rightarrow electroneutrality. Due to the high concentration and small size of electrons in the metal, the excess charge on the metal is localized at its surface. But due to the low concentration and large size of ions in solution, any neutralizing charge in the solution is distributed over a finite region of space. This region of space may be imagined as consisting of three zones of different character. There is a near-field region in which desolvated ions are essentially immobilized in contact with the metal surface. The forces involved are both electrostatic and quantum in character. There is an intermediate-field region in which ions are continuously undergoing \rightarrow solvation/desolvation processes driven by electrostatic forces, and finally there is a far-field region in which fully solvated ions are undergoing continuous place-exchange with ions from the bulk of solution. This latter region is known as the \rightarrow diffuse layer. There is some experimental support for the idea that the total capacitance of the three regions of solution adjacent to an electrode surface may be treated as three capacitors in series:

$$1/C_T = 1/C_1 + 1/C_2 + 1/C_d,$$

where the diffuse layer capacitance C_d is given by \rightarrow Chapman's formula

$$C_d = A \left(\frac{2\varepsilon_r \varepsilon_0 e^2 z_i^2 c_i}{kT} \right)^{1/2} \cosh \left(\frac{ez \langle V(a) \rangle}{2kT} \right).$$

Here ε_r is the relative \rightarrow permittivity (static dielectric constant) of the solution, ε_0 is the permittivity of free space, e is the unit charge on the electron (\rightarrow elementary electric charge), z_i is the valence of the ionic species i , c_i is the bulk concentration of the adsorbing species i , k is the \rightarrow Boltzmann constant, T is the absolute temperature, and $\langle V(a) \rangle$ is the time-averaged value of the electric potential difference across the diffuse layer. The diffuse layer capacitance is (very roughly) of the order of $10 \mu\text{F cm}^{-2}$. The "thickness" of the diffuse layer is essentially the \rightarrow Debye length L_D ,

$$L_D = \left(\frac{\varepsilon_r \varepsilon_0 RT}{F^2 \sum_i c_i z_i^2} \right)^{1/2},$$

where ε_r is the relative permittivity (static dielectric constant) of the solution, ε_0 is the permittivity of free space, R is the \rightarrow gas constant, T is the absolute temperature, F is the \rightarrow Faraday constant, c_i is the bulk concentration of species i , and z_i is the valence of species i .

Ref.: [i] Parsons R (1954) *Equilibrium properties of electrified interphases*. In: Bockris JO'M, Conway BE (eds) *Modern aspects of electrochemistry*. Academic Press, New York

SF

Diffuse reflection spectroscopy \rightarrow spectroscopy

Diffusion — Diffusion is transport of particles caused by the local difference in the chemical potential [i]. The flux, J , of particles is proportional to the gradient of the concentration. See \rightarrow Fick's first law. This equation can be derived thermodynamically by equating the force acting on a spherical particle by the \rightarrow chemical potential gradient with the frictional force. When the particle in radius a moves at velocity v in the medium of the \rightarrow viscosity η , the Stokes' law mentions that the force is given by $6\pi\eta a v$ (\rightarrow Stokes' viscous force). When the chemical potential per particle is expressed by $\mu^\ominus + k_B T \ln(c/c^\ominus)$, the force of the one-dimensional gradient is given by $-(k_B T/c)(\partial c/\partial x)$, where μ^\ominus is the standard chemical potential, k_B is the \rightarrow Boltzmann constant, and c^\ominus is the standard concentration. Letting the molar flow rate of the species be $J = cv$, the balance of the forces, $-(k_B T/c)(\partial c/\partial x) = 6\pi\eta a(J/c)$, yields $J = -D(\partial c/\partial x)$, where $D = k_B T/6\pi\eta a$ is the \rightarrow diffusion coefficient [ii]. The relation is the \rightarrow Stokes-Einstein equation. Electrochemical reactions are heterogeneous and hence they are frequently controlled by diffusion. When the concentration gradient near the electrode is large, the current density is expressed by $j = nF(J)_{x=0} = -nFD(\partial c/\partial x)_{x=0}$. When the Fick's first law is combined with the equation of continuum, $\partial c/\partial t = -\partial J/\partial x$, in the one-dimensional space, it becomes the Fick's second law, $\partial c/\partial t = D(\partial^2 c/\partial x^2)$, for the diffusion coefficient independent of x . A diffusion problem in electrochemistry lies in solving the diffusion equation together with initial conditions and boundary conditions. Diffusion is always coupled to \rightarrow charge-transfer reactions. See also \rightarrow mass transport, \rightarrow electrode processes.

Refs.: [i] Kittel C (1969) *Thermal physics*, 3rd edn. Wiley, New York, p 215;

[ii] Atkins PW (1998) *Physical chemistry*, 6th edn. Oxford University Press, Oxford, p 748

KA

Ambipolar diffusion \rightarrow ambipolar conductivity

Convective diffusion — The electrochemical \rightarrow mass transport controlled by both \rightarrow convection and \rightarrow diffusion is called a process by convective diffusion [i]. Convection is caused by externally controlled force or spontaneous force. Convective diffusion has been conventionally used in a strict sense for well-controlled flow such as for \rightarrow rotating disk electrodes [ii], \rightarrow channel elec-

trodes (\rightarrow flow-through electrodes) and \rightarrow wall-jet electrodes. Convective diffusion is also operative in case of \rightarrow dropping mercury electrodes in \rightarrow polarography. Spontaneous flow occurs when heterogeneous density distribution of reactants or products causes natural convection of solution for long electrolysis. Convective diffusion increases the current of the electroactive species by the flow rate, v . When there is no effect of electric \rightarrow migration, the flux is expressed by $J = -D \text{grad } c + cv$, where D is the \rightarrow diffusion coefficient and c is the concentration. Combining it with the equation of continuum, $\partial c/\partial t = -\text{div } J$, yields $\partial c/\partial t = D\nabla^2 c - v \cdot \nabla c$. The expression of v as a function of time and space can be obtained from the \rightarrow Navier–Stokes equation.

Refs.: [i] Bard AJ, Faulkner LR (2001) *Electrochemical methods*, 2nd edn. Wiley, New York, pp 332; [ii] Opekar F, Beran P (1976) *J Electroanal Chem* 69:1

Concentration profile caused by diffusion —

Formation or consumption of reacting species at the electrode surface causes concentration distribution of electroactive species in the solution phase during electrolysis. Equi-concentration contours stand for a concentration profile. A concentration profile can be measured by detecting \rightarrow current or \rightarrow potential by use of a small probe electrode at various locations near a target large electrode. A typical method is scanning electrochemical microscopy. See also \rightarrow diffusion layer, \rightarrow scanning electrochemical microscope.

KA

Edge diffusion —

The diffusion edge is the fictional boundary between the diffusion layer and the bulk. It is a convenient concept when an extending diffusion later reaches an object to react, e.g., at a pair electrode and a \rightarrow scanning electrochemical microscope [i].

Ref.: [i] Bard AJ, Faulkner LR (2001) *Electrochemical methods*, 2nd edn. Wiley, New York, p 669

KA

Finite diffusion —

Finite (sometimes also called \rightarrow limited) diffusion situation arises when the \rightarrow diffusion layer, which otherwise might be expanded infinitely at long-term electrolysis, is restricted to a given distance, e.g., in the case of extensive stirring (\rightarrow rotating disc electrode). It is the case at a thin film, in a thin layer cell, and a thin cell sandwiched with an anode and a cathode. Finite diffusion causes a decrease of the current to zero at long times in the \rightarrow Cottrell plot (\rightarrow Cottrell equation, and \rightarrow chronoamperometry) or for voltammetric waves (see also \rightarrow electrochemical impedance spectroscopy). Finite diffusion generally occurs at \rightarrow hydrodynamic electrodes.

KA

Refs.: [i] Crank J (1975) *The mathematics of diffusion*, 2nd edn. Clarendon Press, Oxford, chap 3; [ii] Jost W (1960) *Diffusion in solids, liquids, gases*, 3rd edn. Academic Press, New York

KA

Hemispherical diffusion —

Electrolysis at a hemispherical electrode provides hemispherical diffusion. A hemispherical electrode can be constructed by plating mercury onto an inlaid disk metal [i]. It is not easy to control the geometry accurately. A hemispherical electrode has often been employed for a model of the microelectrode behavior because three-dimensional \rightarrow mass transport can be reduced mathematically to the one-dimensional mass transport. This model has been applied to estimation of charge transfer kinetics, effect of electric migration, and chemical complications. The time-dependent diffusion equation at the hemispherical or a spherical electrode is given by $\partial c/\partial t = D(\partial^2 c/\partial r^2 + (2/r)\partial c/\partial r)$. The substitution of $c = y/r$ alters this equation to the one-dimensional diffusion equation at the Cartesian coordinate ($\partial y/\partial t = D\partial^2 y/\partial r^2$). The diffusion equation has the steady-state solution, $c = c^*(1 - r_0/r)$, for the radius r_0 of the spherical electrode when concentration at the electrode surface is zero and the bulk concentration is c^* [i]. Then the steady-state diffusion current is given by $I = 2\pi r_0 F D c^*$.

D

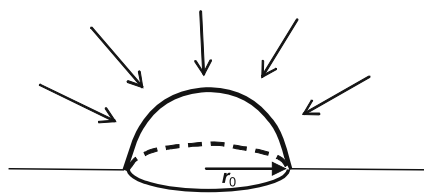

Diffusion — Hemispherical diffusion — Figure

Refs.: [i] Demaille C, Brust M, Tsionsky M, Bard AJ (1997) *Anal Chem* 69:2323; [ii] Bard AJ, Faulkner LR (2001) *Electrochemical methods*, 2nd edn. Wiley, New York, p 165

KA

Limited diffusion —

applies to a thin film or a \rightarrow thin layer cell. Limited diffusion causes a decrease of the current to zero at long times (i.e., the \rightarrow Cottrell equation will then not any more be followed; \rightarrow chronoamperometry) or at the voltammetric waves (\rightarrow cyclic voltammetry) because there is not an infinite reservoir of electroactive species. (See also \rightarrow electrochemical impedance spectroscopy.)

KA

Nernst diffusion layer — is the domain in which diffusion caused by electrode reactions occurs predom-

inantly, and is often used for the \rightarrow *diffusion layer* under the presumed steady-state conditions even if the current varies with time. See also \rightarrow *Nernst layer*.

Ref.: [i] Bard AJ, Faulkner LR (2001) *Electrochemical methods*, 2nd edn. Wiley, New York, p 29

Planar diffusion — is one-directional diffusion of electroactive species to and from an electrode, and is also called linear diffusion. It is observed when a characteristic length of an electrode is larger than the diffusion layer thickness [i]. A disk electrode with a radius larger than 0.2 mm usually exhibits planar diffusion for a simple redox couple. See \rightarrow *diffusion layer thickness*, \rightarrow *radial diffusion*.

Refs.: [i] Aoki K, Akimoto K, Tokuda K, Matsuda H, Osteryoung J (1984) *J Electroanal Chem* 171:219; [ii] Bard AJ, Faulkner LR (2001) *Electrochemical methods*, 2nd edn. Wiley, New York, p 161

Radial diffusion — Diffusion converging to a point is called radial diffusion, and is applied for diffusion at small microelectrodes when the radius of the electrode is much larger than the diffusion layer thickness estimated from $(Dt)^{1/2}$. Genuine radial diffusion occurs at a spherical electrode. However, radial diffusion is sometimes used for diffusion at an edge of a planar electrode, which is also called lateral diffusion. See also \rightarrow *hemispherical diffusion*.

Semi-infinite diffusion — One-dimensional diffusion toward both $x = \infty$ and $x = -\infty$ is called infinite diffusion, whereas that toward only one direction with $x = \infty$ is called semi-infinite diffusion. Diffusion associated with electrochemical \rightarrow *mass transport* often belongs to the latter category. Semi-infinite diffusion has the boundary condition: $\lim_{x \rightarrow \infty} c(x, t) = c^*$ where c^* is the bulk concentration. See also \rightarrow *finite diffusion*.

Spherical diffusion \rightarrow *hemispherical diffusion*

Diffusion coefficient — The diffusion coefficient, D , is a proportion coefficient for the \rightarrow *Fick's first law*. The values in liquid are of the order of $10^{-5} \text{ cm}^2 \text{ s}^{-1}$, whereas those in solids are often less than $10^{-8} \text{ cm}^2 \text{ s}^{-1}$. The diffusion coefficient of hydrogen ion in water is exceptionally large ($10^{-4} \text{ cm}^2 \text{ s}^{-1}$) because hydrogen ion can propagate via cleavage and formation of the hydrogen bonds with neighboring water molecules [i]. The diffusion coefficient is inversely proportional to the radius of diffusing species and inversely proportional to the \rightarrow *viscosity* of the medium. Electrochemical currents are often controlled by diffusion and hence depend on D . Values of D

can be evaluated from diffusion-controlled current. The diffusion coefficient of a spherical particle can be estimated from the \rightarrow *Stokes-Einstein equation* for known values of the radius and the viscosity of the medium. See also \rightarrow *diffusion*.

Ref.: [i] Atkins PW (1998) *Physical chemistry*, 6th edn. Oxford University Press, Oxford, p 741

Diffusion coefficient: determination in solids —

For \rightarrow *solid materials* with predominant \rightarrow *ion conductivity* (\rightarrow *solid electrolytes*), the diffusion coefficient of mobile ions can be calculated from the bulk \rightarrow *conductivity* using the \rightarrow *Nernst-Einstein equation*, provided that the \rightarrow *charge carrier* concentration is known. Such information is readily available for materials where all ions contributing to the transport processes are energetically equivalent. In this case, the concentration can be determined from structural and/or chemical analysis data. For materials where the probability of an ion jump is strongly dependent on crystallographic position of the given ion, only a macroscopic analysis of diffusion processes is possible until obtaining detailed information on the crystal structure and energetic factors.

Powerful methods for the determination of diffusion coefficients relate to the use of tracers, typically radioactive isotopes. A diffusion profile and/or time dependence of the isotope concentration near a gas/solid, liquid/solid, or solid/solid interface, can be analyzed using an appropriate solution of \rightarrow *Fick's laws* for given boundary conditions [i–iii]. These methods require, however, complex analytic equipment. Also, the calculation of self-diffusion coefficients from the tracer diffusion coefficients makes it necessary to postulate the so-called correlation factors, accounting for nonrandom migration of isotope particles. The correlation factors are known for a limited number of lattices, whilst their calculation requires exact knowledge on the microscopic diffusion mechanisms.

The diffusion coefficients can be assessed studying the product formation rate in diffusion couples, or the diffusion rate from a gas phase or a liquid into a solid material (e.g., metal oxidation rates) [i–iii]. In this case, however, the results may be affected by microstructural and interfacial factors due to transport in pores, surface diffusion, limited contact area between solid phases, formation of multiple reaction products, etc.

The \rightarrow *current efficiency* methods are based on the analysis of amount of electrochemical reaction products during or after passing an electrical current through a material [ii–v]. Taking into account the electrode polarization, one can then determine the ion \rightarrow *trans-*

KA

KA

KA

KA

KA

port number; the ionic conductivity and macroscopic diffusion coefficients can then be calculated using a complementary information, at least total conductivity. These methods can be used with a high accuracy for a limited range of ion transference numbers. Another problem may appear if the charge carrier concentration depends significantly on the applied \rightarrow voltage.

Similar approaches are used for most steady-state measurement techniques developed for mixed ionic-electronic conductors (see \rightarrow conductors and \rightarrow conducting solids). These include the measurements of concentration-cell \rightarrow electromotive force, experiments with ion- or electron-blocking electrodes, determination of \rightarrow electrolytic permeability, and various combined techniques [ii–vii]. In all cases, the results may be affected by electrode polarization; this influence should be avoided optimizing experimental procedures and/or taken into account via appropriate modeling. See also \rightarrow Wagner equation, \rightarrow Hebb–Wagner method, and \rightarrow ambipolar conductivity.

As for the permeability measurements, most techniques based on the analysis of transient behavior of a mixed conducting material [iii, iv, vii, viii] make it possible to determine the ambipolar diffusion coefficients (\rightarrow ambipolar conductivity). The transient methods analyze the kinetics of weight relaxation (gravimetry), composition (e.g. coulometric \rightarrow titration), or electrical response (e.g. conductivity \rightarrow relaxation or potential step techniques) after a definite change in the \rightarrow chemical potential of a component or/and an \rightarrow electrical potential difference between electrodes. In selected cases, the use of blocking electrodes is possible, with the limitations similar to steady-state methods. See also \rightarrow relaxation techniques.

Finally, the diffusion coefficients can also be estimated using alternative techniques, such as the analysis of Hall effect, electrode reaction kinetics, or solids decomposition rate.

Refs.: [i] Ghez R (2001) *Diffusion phenomena*. Kluwer, New York; [ii] Kröger FA (1964) *The chemistry of imperfect crystals*. North-Holland, Amsterdam; [iii] Chebotin VN (1989) *Chemical diffusion in solids*. Nauka, Moscow; [iv] Rickert H (1982) *Electrochemistry of solids*. An introduction. Springer, Berlin; [v] Kharton VV, Marques FMB (2001) *Solid State Ionics* 140:381; [vi] Wagner C (1936) *Z phys Chem B* 32:447; [vii] Bouwmeester HJM, Burggraaf AJ (1996) *Dense ceramic membranes for oxygen separation*. In: Burggraaf AJ, Cot L (eds) *Fundamentals of inorganic membrane science and technology*. Elsevier, Amsterdam, pp 435–528; [viii] Belzner A, Gür TM, Huggins RA (1990) *Solid State Ionics* 40/41:535

Diffusion coefficient of metals in mercury —

When metal ion in solution is reduced to metal at a mercury electrode, the metal in mercury or amalgam is transported from the interface to the mercury bulk by diffusion. Diffusion coefficients of amalgam are determined by means of the double potential step method at a \rightarrow hanging mercury drop electrode [i]. Amalgam is formed at the cathodic electrolysis of which charge determines the average concentration of the amalgam. The succeeding anodic potential step chronoamperometric current (\rightarrow chronoamperometry) allows us to evaluate diffusion coefficients of amalgam. Most values range from $(0.7 \text{ to } 1.6) \times 10^{-5} \text{ cm}^2 \text{ s}^{-1}$.

Ref.: [i] Galus Z (1984) *Pure Appl Chem* 56:635

KA

Diffusion-controlled rate — of an electrochemical reaction is encountered if diffusion of a redox species to the electrode surface is the most hindered (slowest) step in the overall transport process including mass transport, \rightarrow chemical reaction and \rightarrow electrode reaction.

Ref.: [i] Muller P (1994) *Pure Appl Chem* 66:1077

WK

Diffusion layer — The diffusion layer is an imaginary layer of predominant occurrence of diffusion or a heterogeneous concentration by electrolysis, as shown in the Figure [i]. It is used conveniently when we want to conceptually separate a domain of charge transfer, a domain of diffusion, and a bulk. The diffusion layer thickness can be estimated $(Dt)^{1/2}$ for the electrolysis time, t , and ranges from 0.01 mm to 0.1 mm. When current is controlled by diffusion, the thickness can also be estimated from the current density, j , through DcF/j , which is due to finite values of the differentiation in $j = FD(\partial c/\partial x)$. The concept of the diffusion layer is im-

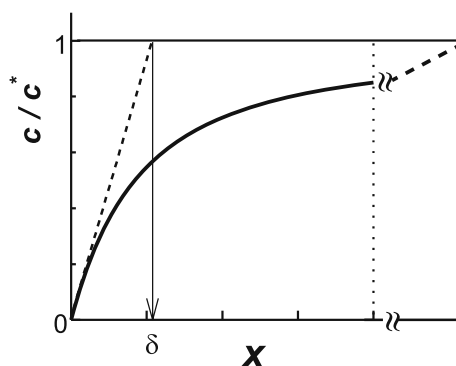

VK Diffusion layer — Figure

portant when a rate-determining step is determined to be either diffusion, chemical complications, or electron transfer kinetics.

See also → *Nernst layer*, → *Fick's law*.

Ref.: [i] Koryta J, Dvorak J, Bohackova V (1973) *Electrochemistry*. Methuen & Co, p 119

KA

Diffusion layer thickness → *diffusion layer*

Diffusion overpotential — The diffusion overpotential means the extra voltage which could compensate the difference between bulk concentration and surface concentration, and is called → *concentration overpotential* [i]. As a performance of industrial electrolysis or batteries, it has been used along with → *activation overpotential* and → *ohmic overpotential*. It not only varies complicatedly with cell configuration, current, applied voltage, and electrolysis time but also cannot be separated from activation and ohmic overpotentials.

Ref.: [i] Newman, JS (1991) *Electrochemical systems*. Prentice-Hall, Englewood Cliffs, p 13

KA

Diffusion potential → *potential*, subentry → *diffusion potential*

Diffusion time (diffusion time constant) — This parameter appears in numerous problems of → *diffusion*, diffusion-migration, or convective diffusion (→ *diffusion*, subentry → *convective diffusion*) of an electroactive species inside solution or a solid phase and means a characteristic time interval for the process to approach an equilibrium or a steady state after a perturbation, e.g., a stepwise change of the electrode potential. For one-dimensional transport across a uniform layer of thickness L the diffusion time constant, τ_d , is of the order of L^2/D (D , → *diffusion coefficient* of the rate-determining species). For spherical diffusion (inside a spherical volume or in the solution to the surface of a spherical electrode) $\tau_d = R^2/D$ (R , radius of sphere) (→ *diffusion*, subentry → *spherical diffusion*). The same expression is valid for hemispherical diffusion in a half-space (occupied by a solution or another conducting medium) to the surface of a disk electrode, R being the disk radius (→ *diffusion*, subentry → *hemispherical diffusion*). For the relaxation of the concentration profile after an electrical perturbation (e.g., a potential step) $\tau_d = L_D^2/D$; L_D being → *diffusion layer thickness* in steady-state conditions. All these expressions can be derived from the qualitative estimate of the thickness of the nonstationary layer

with the perturbed concentration profile within a short-time interval, t , after the local concentration perturbed: $\delta_t \sim (Dt)^{1/2}$. The above parameter, τ_d , can be estimated as the time needed for the perturbation propagation to the whole spatial area in which the equilibrium concentration profile changed, i.e., from the relation $\delta_t(\tau_d) \sim L$ or R or L_d .

Ref.: [i] Barsoukov E, Macdonald JR (ed) (2005) *Impedance spectroscopy. Theory, experiment, and applications*. Wiley, Hoboken

MAV

Digital filter — A mathematical algorithm implemented by software used to eliminate unwanted frequencies from a measured signal and thus, increase the → *SNR*. Some of the most commonly used numerical signal enhancement techniques are:

- **Boxcar averaging** A software technique based on replacing a group of closely spaced digital data that depicts a relatively slow changing signal by a single point that represents the average of the group. This technique is a digital low-pass filter that can be often implemented simultaneously with the acquisition of the data (*real time*) since one group of data (*boxcar*) can be acquired and averaged before the next boxcar arrives. Enhancement of the → *SNR* can be calculated as: $SNR = \sqrt{n}SNR_0$, n is the number of points averaged in each boxcar and SNR_0 is the → *SNR* of the untreated data [i].
- **Ensemble averaging** A technique based on the average of n repeated sets of measurements of the same phenomenon. It can be applied to signals that are changing rapidly and thus, it can be implemented as a complement of the boxcar method. Enhancement of the → *SNR* can be calculated as: $SNR = \sqrt{n}SNR_0$, n is the number of sets of measurements that are averaged and SNR_0 is the → *SNR* of the untreated data. The acquisition time can be greatly reduced by using → *Fourier transformation* for data processing, since pulsed signals instead of conventional scans can be analyzed. These pulsed signals include all the frequencies of the spectral range of the instrument, but the information is enclosed in the form of superimposed waves. → *Fourier transformation* is then used to convert these data from time-domain to frequency-domain. Thus, results appear as a conventional frequency spectrum that can be easily averaged [i].
- **Weighted digital filtering** A software technique in which different weights to points as a function of

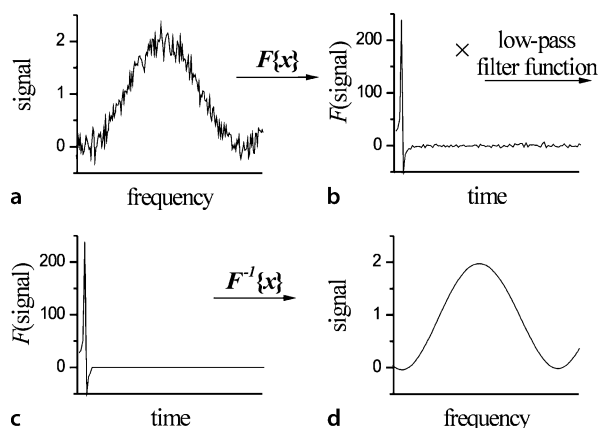

Digital filter — Figure

their position relative to the central point are assigned to produce a more realistic filtering. Adjustable filtering parameters include the mathematical smoothing function, the number of points, the relative position of points regarding the central point in the moving average, and the number of times the data are processed by the smoothing function. This technique offers optimum flexibility in the choice of filter algorithms since it can be implemented as low-pass, high-pass, band-pass or band-stop filter. Weighted digital filters can be divided in two big groups of filters: \rightarrow recursive filters and \rightarrow nonrecursive filters [ii]. However, data can also be filtered by transforming their respective amplitude–frequency spectrum to an amplitude–time spectrum using \rightarrow Fourier transforms, Fig. b. The resulting waveform is then multiplied by an appropriate mathematical filter function to obtain the desired frequency response, Fig. c. Finally, the inverse Fourier transformation regenerates the filtered amplitude–frequency spectrum, Fig. d [i].

Refs.: [i] Willard HH, Merritt LL, Dean JA, Settle FA (1988) *Instrumental methods of analysis*. Wadsworth, California; [ii] Oppenheim AV, Schaffer RW (1999) *Discrete-time signal processing*. Prentice-Hall, New Jersey

FG

Digital simulation — Data from electrochemical experiments such as \rightarrow cyclic voltammetry are rich in information on solution composition, diffusion processes, kinetics, and thermodynamics. Mathematical equations describing the corresponding parameter space can be written down but can be only very rarely solved analytically. Instead computer algorithms have been devised to ac-

curately reproduce current – potential data for complex electrode processes and to allow voltammetric data to be analyzed quantitatively [i, ii].

In digital simulation time and space can be discretized and the appropriate differential equations allow diffusion and reaction processes to be visualized. A wide range of approaches (explicit, implicit, finite difference, orthogonal collocation, Monte Carlo, etc. [ii]) has emerged to deal with specific problems such as fast chemical reactions, diffusion to complex shapes. Several free or commercial software packages are available [ii]. Fitting of simulated voltammograms to experimental voltammograms allows even complex mechanisms and multi-component reactions to be disentangled and analyzed [iii]. Digital simulation may also be applied to data analysis in \rightarrow spectroelectrochemistry or for processes in heated electrochemical cells (\rightarrow heated electrodes) [iv].

Refs.: [i] Britz D (2005) *Digital simulation in electrochemistry*. Springer, Berlin; [ii] Speiser B (1996) *Numerical simulation of electroanalytical experiments: Recent advances in methodology*. In: Bard AJ, Rubinstein I (eds) *Electroanalytical chemistry*, vol. 19. Marcel Dekker, New York; [iii] Prenzler PD, Boskovic C, Bond AM, Wedd AG (1999) *Anal Chem* 71:3650; [iv] Tsai YC, Coles BA, Compton RG, Marken F (2002) *J Am Chem Soc* 124:9784

FM

Digital-to-analog converter (DAC) — An electronic device that transforms a digital input signal (most often binary) to appropriate analog voltage signal with given proportionality. The output range of the device is usually $0 \div 1$ V. The resolution of the transformed points is determined by the number of bits the converter works with. Sufficient accuracy in electrochemistry is usually obtained with 16-bit converters. The reverse transformation process is accomplished with analog-to-digital converters.

Refs.: [i] Bard AJ, Faulkner LR (2001) *Electrochemical methods*, 2nd edn. Wiley, New York, p 632

ZS

Dimensionally stable anode (DSA) \rightarrow dimensionally stable electrodes, \rightarrow electrode materials, subentry \rightarrow ORTA

Dimensionally stable electrodes — Electrodes (in particular anodes) which remain dimensionally stable during prolonged operation. Many metal and carbon electrodes undergo severe \rightarrow corrosion when employed as cathodes or as anodes. For industrial applications this is not acceptable and metal oxide-based electrodes were discovered as an important alternative [i]. Dimensionally stable oxide electrodes are manufactured by coating

an electrically conducting mixed oxide layer (containing Ti, Ru, Ir oxides) onto titanium substrates [ii]. Today dimensionally stable anodes (DSAs) are widely used in chlorine production, in wastewater treatment systems, in dialysis systems, in \rightarrow *supercapacitors*, in \rightarrow *electrosynthesis*, and in many other applications. The lifetime of DSAs in chlorine production can be in excess of 10 years. See also \rightarrow *electrode materials*, subentry \rightarrow ORTA.

Refs.: [i] Beer HB (1965) Brit Patent 1147442; [ii] Trasatti S (2000) *Electrochim Acta* 45:2377

FM

Dimensionless analysis — Use of dimensionless parameters (\rightarrow *dimensionless parameters*) to characterize the behavior of a system (\rightarrow *Buckingham's π -theorem and dimensional analysis*). For example, the chronoamperometric experiment (\rightarrow *chronoamperometry*) with semi-infinite linear geometry relates flux at $x = 0$ ($f_{x=0}$, units: moles $\text{cm}^{-2} \text{s}^{-1}$), time (t , units: s^{-1}), diffusion coefficient (D , units: $\text{cm}^2 \text{s}^{-1}$), and concentration at $x = \infty$ (c_∞ , units: moles cm^{-3}). Only one dimensionless parameter can be created from these variables (\rightarrow *Buckingham's π -theorem and dimensional analysis*) and that is $f_{x=0} (t/D)^{1/2} / c_\infty$ thereby predicting that $f_{x=0} t^{1/2}$ will be a constant proportional to $D^{1/2} c_\infty$, a conclusion reached without any additional mathematical analysis. Determining that the numerical value of $f_{x=0} (t/D)^{1/2} / c_\infty$ is $1/\pi^{1/2}$ or the concentration profile as a function of x and t does require mathematical analysis [i].

Ref.: [i] Bard AJ, Faulkner LR (2001) *Electrochemical methods*. 2nd edn. Wiley, New York, pp 161–164

SWF

Dimensionless parameters — A dimensionless parameter is a dimensionless grouping of [usually dimensioned] physical parameters sometimes referred to as “ π groups” (see \rightarrow *Buckingham's π -theorem and dimensional analysis*). For example, given the dimensioned physical parameters k (s^{-1}), k^0 (cm s^{-1}), t (s), D ($\text{cm}^2 \text{s}^{-1}$), E ($V = JC^{-1}$), F (C mole^{-1}), R ($\text{J mole}^{-1} \text{K}^{-1}$), T (K), v (V s^{-1}) one can construct the following dimensionless groupings: kt , FE/RT , $k^0/(FDv/RT)^{1/2}$, $k^0/(D/t)^{1/2}$. The number of dimensionless groupings (four in this example) is predicted by Buckingham's π -theorem. A dimensionless group which can be produced by the combination of two or more other dimensionless groups may be more convenient in form for a particular application but is not counted as a new group. For the example considered here, the dimensionless grouping kRT/Fv , particularly useful for \rightarrow *cyclic voltammetry*, can be formed from: kt , $k^0/(FDv/RT)^{1/2}$ and $k^0/(D/t)^{1/2}$. Other ex-

amples: steady-state current-voltage data for a \rightarrow *rotating disk electrode* (RDE) or *ultramicrodisk electrode* (UMDE) (\rightarrow *ultramicroelectrode*) may be presented as i/i_{lim} vs. $F(E - E_c^\ominus)/RT$. Either of these examples could also be a function of one or more additional dimensionless parameters, e.g.: $k^0/(\omega D)^{1/2}$ for the RDE response or $k^0 r_0/D$ for the UMDE response where ω (s^{-1}) is the rotation rate of the RDE and r_0 (cm) is the radius of the UMDE.

When concentration profiles are of interest the concentrations are often expressed as a fraction of some reference concentration – e.g., the bulk concentration of the analyte. The resulting dimensionless concentration(s), c_j/c_{ref} can then be shown as a function of dimensionless distance, e.g., x/r_0 (for a UMDE), $x(\omega/D)^{1/2}$ (for an \rightarrow *rotating disc electrode*), $x/(Dt)^{1/2}$ (for a chronoamperogram) or $x(F|v|RTD)^{1/2}$ (for a cyclic voltammogram).

SWF

Dimensionless potential \rightarrow *potential*, subentry \rightarrow *dimensionless potential*

Dimerization — is the transformation of two, identical \rightarrow *molecular entities* A to give a \rightarrow *molecular entity* A₂. For instance, in homogeneous chemical reactions:

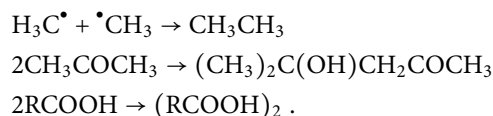

In electrochemical reactions, the electrode processes are accompanied by dimerization of the primary product formed during these processes. Three general electrochemical mechanisms of dimerization are distinguished.

DIM 1: dimerization of the radical product of a one-electron reduction.

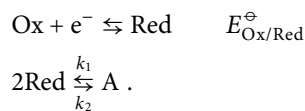

DIM 2: reaction of the radical product of a one-electron reduction with a substrate.



It is assumed that the following relation holds for the standard potentials: $E_{\text{Ox/Red}}^\ominus < E_{\text{RO/RR}^\bullet}^\ominus$

There are three types of DIM 2 mechanisms. In DIM 2-ECE, the dimerization reaction is the chemical step separating two electrode processes while in the DIM 2-DISP 1 and DIM 2-DISP 2 dimers are formed in the disproportionating reactions that follow the electrode process.

DIM 3: reaction of the product of a two-electron reduction with a substrate

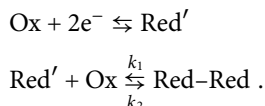

It is assumed that the Red–Red dimer is electroinactive in the potential range corresponding to formation of Red or Red' and that the chemical step is irreversible.

Kinetic parameters of dimerization can be determined by → *polarography*, → *chronoamperometry*, → *linear potential scan* and → *convolution voltammetry*, → *rotating disc voltammetry*, and alternating current sinusoidal polarography. See also → *association*.

Refs.: [i] Muller P (1994) *Pure Appl Chem* 66:1077; [ii] Galus Z (1994) *Fundamentals of electrochemical analysis, 2nd edn.* Ellis Horwood, New York, Polish Scientific Publ PWN, Warsaw

WK

Dimethyl sulfoxide (DMSO) — Organic solvent ((CH₃)₂SO or DMSO, melting point 18 °C, boiling point 189 °C) with a density (1.10 g cm⁻³ at 25 °C) higher than water. DMSO is highly polar (dielectric constant ε_r = 46.45) and hygroscopic. DMSO is miscible with water in any ratio and can be dried over 4 Å molecular sieves [i].

Ref.: [i] Reichardt C (2003) *Solvents and solvent effects in organic chemistry.* Wiley-VCH, Weinheim

FM

Diode array spectrometer → *spectrometer*

Diosmosis → *osmosis*

Dipolar bond — A bond formed (actually or conceptually) by coordination of two neutral moieties, the combination of which results in charge-separated structures, e.g.,

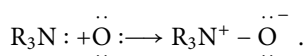

The term is preferred to the obsolescent synonyms “co-ordinate link”, “co-ordinate covalence”, “dative bond”, “semipolar bond”.

Ref.: [i] Muller P (1994) *Pure Appl Chem* 66:1077

WK

Dipolaron → *electronic defects*, and → *polaron*

Dipolar solvents — These solvents are also called polar aprotic solvents. They are characterized by a comparatively high relative → *permittivity* (or → *dielectric constant*), greater than ca. 15, and a sizable permanent dipole moment, usually greater than ca. 2.5, as compared to nonpolar solvents that possess low permittivity. Examples of dipolar aprotic solvents are ketones, alkyl carbonates, esters, sulfoxides, nitro compounds, nitriles, *N,N*-disubstituted amides of carbon acids, etc. Though the term polar and nonpolar are used in the literature for solvent characterization both with respect to relative permittivity and dipole moment, these values do not vary in parallel. The solvents with a high dielectric constant act as dissociating solvents. With respect to dielectric constant, the polarity is determined by the sum of all of the molecular properties, which are responsible for the interaction forces between the molecules of the solute and solvent (coulombic, orientation, inductive and dispersive forces, interactions with the charge transfer, and H-bond formation). For example, benzene is a nonpolar solvent in terms of dipole moment, but it possesses a solvating ability. From the electrochemical point of view, the most important property of the solvents is their ability to solvate anions and cations. This ability is very well expressed by the so-called donor and acceptor properties. Polar aprotic solvent donor and acceptor properties are classified and evaluated by the → *donor number* (DN) and → *acceptor number* (AN), introduced by Gutmann and Wychera. DN is defined as the molar enthalpy value for the reaction of the solvent with the reference acceptor antimony (V) chloride in a 10⁻³ mol L⁻¹ solution in dichloroethane. For the characterization of the solvent acceptor properties, the AN has been proposed, which is derived from values of the ³¹P-NMR chemical shifts of triethylphosphine oxide in the respective pure solvent. Dipolar aprotic solvents are widely used in modern electrochemistry in the branch called → *nonaqueous electrochemistry*. For instance, the field of → *lithium batteries* involves the extensive use of such solvents in the electrolyte solutions.

Refs.: [i] Gutmann V, Resch G (1995) *Lecture notes on solution chemistry.* World Scientific Publishing, Singapore; [ii] Reichardt C (2003) *Solvents and solvent effects in organic chemistry, 3rd edn.* Wiley-VCH, Weinheim; [iii] Aurbach D (ed) (2002) *Nonaqueous electrochemistry.* Marcel Dekker, New York; [iv] Izutsu K (2002) *Electrochemistry in nonaqueous solutions.* Wiley-VCH, Weinheim

DA, EM

Dipole — is the general term applied for two spatially distinct electric or magnetic charges (or poles) of equal amount, but spatially separated. A measure of the strength of a dipole is the \rightarrow *dipole moment*. In a narrow sense, especially in chemistry and physics of matter, dipole is referred to specimens with a permanent dipole moment, and usually to the electric dipole, only. (See also \rightarrow *dipole moment*).

MHer

Dipole–dipole interaction — refers to intermolecular or intramolecular interaction between molecules or groups having a permanent \rightarrow *dipole moment*, μ . The potential energy of the interaction, V , is directly proportional to dipole moments of both dipoles and depends on relative orientation of the \rightarrow *dipoles*. For instance, this energy is inversely proportional to the third power of the distance, r , for linearly arranged stationary dipoles of the negative-to-positive directed charges.

$$V = -\frac{2\mu_1\mu_2}{4\pi\epsilon_0 r^3}.$$

The term applies also to intramolecular interactions between bonds having permanent \rightarrow *dipole moments*. See also \rightarrow *van der Waals forces*.

The potential energy of the dipole–dipole interaction is the sum of energy of repulsion of similar charges and attraction of opposite charges.

Refs.: [i] Muller P (1994) *Pure Appl Chem* 66:1077; [ii] Atkins PW (1998) *Physical chemistry*, 6th edn. Oxford University Press, Oxford, chap 22.3

WK

Dipole moment — In chemistry and physics of matter, electric dipole moment is usually the measure of the strength of an electric \rightarrow *dipole* (magnetic d.m. is not treated here). The d.m. $\vec{\mu}$ is a vector quantity, conventionally directed from the negative to the positive center of charge distribution. It is given in Debye units, D (\rightarrow *Debye*). The conversion factor to SI units is 1 D = 3.33564×10^{-30} C m. Usually, molecules have d.m.'s between 0 and 10 D. The d.m. of every atom consists (additively) of the contributions from the positively charged nuclei and negatively charged electrons, respectively, i.e.: $\mu = \mu^+ + \mu^-$. If negative and positive dipole centers are not identical (and if the molecule does not exhibit an inversion center), the molecule owns a permanent d.m. Within an electric field, a d.m. can be induced in an atom or molecule, and a measure of the response of the electron cloud to an external field is the \rightarrow *polarizability* α . There are three main sources of different nature that total polarization of atoms, ions, or molecules

is referred to. The displacement of the center of the local electronic charge cloud around the nucleus under the action of the affecting field E_0 causes electronic polarization, $P_e = N\alpha_e E_0$, where α_e is the electronic polarizability. Ionic polarization arises in ionic materials, because the electric field displaces cations and anions in opposite directions: $P_i = N\alpha_i E_0$, where α_i is the ionic polarizability. For substances with a permanent electric dipole, temperature-dependent orientational polarization may occur, since the alignment of these dipoles leads to an orientational polarizability per molecule, that is: $\alpha_{or} = P^2/3k_B T$, where P is the permanent dipole moment per molecule, k_B is the \rightarrow *Boltzmann constant*, and T is temperature. These three polarization processes in response to the applied electric field strongly depend on – and differ from – the frequency of the latter. D.m. of similar compounds can be in good approximation estimated by (vectorial) adding of bond moments. Experimentally, d.m. values can be determined using dielectricity numbers and density at different temperatures, applying the Debye–Clausius–Mossotti equation. Furthermore, the Stark effect enables the determination from microwave spectra, molecular beam electric resonance, and other high-resolution spectroscopic techniques. D.m. can be calculated *ab-initio*: presently, with ca. 0.05 D accuracy for small molecules. In a solid dielectric medium, the polarization P is defined as d.m. per unit volume averaged over the volume of a crystal cell. See also \rightarrow *dielectric relaxation*.

Refs.: [i] Böttcher CJF (1973) *Theory of electric polarization: Dielectrics in static fields*, vol. 1. (1978) *Dielectrics in time-dependent fields*, vol. 2. Elsevier, Amsterdam; [ii] Lide DR (2003) *Dipole Moments*. In: Lide DR (ed) *CRC handbook of chemistry and physics*, 84th edn. CRC Press, Boca Raton, pp 9–42 – 9–51; [iii] Miller TM (2003) *Atomic and molecular polarizabilities*. In: Lide DR (ed) *CRC handbook of chemistry and physics*, 84th edn. CRC Press, Boca Raton, pp 10–163 – 10–177; [iv] Fredrikse HPR (2003) *Polarizabilities of atoms and ions in solids*. In: Lide DR (ed) *CRC handbook of chemistry and physics*, 84th edn. CRC Press, Boca Raton, pp 12–17 – 12–18

MHer

Dipole-induced dipole forces \rightarrow *van der Waals forces*

Diradical \rightarrow *biradical*

Direct current — Electric current that flows in a constant direction, i.e., a current with constant sign (either + or –). A direct current does **not** periodically change its direction like an \rightarrow *AC current*. AC and DC currents can be superimposed (see also \rightarrow *decoupling of AC and DC currents*).

The terms ‘DC field’, and ‘DC potential’ are, although not strictly correct, used for a situation where an electric field is spread between opposite charges (constant, or changing charges) which do not change their **sign** with time. When the charges are periodically changing their **sign** with a certain frequency this is called an → AC system (alternating current system).

Direct electron transfer → *electron transfer*

Direct-methanol fuel cell (DMFC) — This type of → *fuel cell* is similar to the → *polymer-electrolyte-membrane fuel cell* in what concerns the nature of the → *electrolyte* – a proton conducting membrane, such as a perfluorosulfonic acid polymer. In the DMFC the fuel is → *methanol* (CH₃OH) which is oxidized in the presence of water at the anode and the resulting protons migrate through the electrolyte to combine with the → *oxygen*, usually from air, at the cathode to form water:

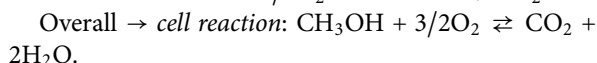
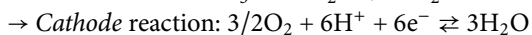
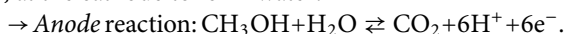

The operating temperature is within the range 50–140 °C (depending on the stability of the electrolyte) and the electrodes consist on dispersions of → *platinum* or platinum alloys catalysts on porous carbon paper.

One of the drawbacks of DMFCs is the relatively slow rate of the anodic oxidation of methanol even on highly active platinum electrodes. It was shown that the Pt–Ru system is much more catalytically active than pure platinum (pure ruthenium is inert towards this reaction) (→ *platinum–ruthenium* → *electrocatalysis*). The so-called bifunctional mechanism is broadly accepted to describe this synergistic effect, according to which organic species are chemisorbed predominantly on platinum centers while ruthenium centers more readily adsorb species OH, required for the oxidation of the organic intermediates. Usually the composition of such alloys is Pt_{0.5}Ru_{0.5} and the metal loading is 2–4 mg cm^{−2}.

The major problem associated with the operation of DMFCs is the gradual diffusion of methanol through the membrane – known as “methanol crossover” – that leads to the establishment of a mixed potential at the cathode and, consequently, to a decrease of the working voltage of the cell. Because of the methanol crossover phenomenon, the maximum methanol concentration used in DMFCs is about 2 M and membranes as thick as 175 μm are used.

The net electrical efficiency of a DMFC is about 40%. At 140 °C a power density of 0.4 W cm^{−2} at a cell potential of 0.35 V (0.12 W cm^{−2}/0.35 V at 90 °C) was recorded.

Refs.: [i] Costamagna P, Srinivasan S (2001) *J Power Sources* 102:242; [ii] Costamagna P, Srinivasan S (2001) *J Power Sources* 102:253; [iii] Narayanan S, Zawodzinski T, Gottesfeld S (eds) (2001) *Direct methanol fuel cells*. The Electrochemical Society, Washington

FS

JC

Direct mirage effect — A deflection signal usually associated with photothermal experiments in which the deflected probe light beam passes on the same side of the photoilluminated → *interface* [i]. See also → *photothermal deflection spectroscopy*.

Ref.: [i] Terazima M, Hirota N, Braslavsky S, Mandelis A, Bialkowski S, Diebold G, Miller R, Fournier D, Palmer R, Tam A (2004) *Pure Appl Chem* 76:1083

FG

Dirichlet boundary condition — A Dirichlet boundary condition specifies the value of a function at a surface. In electrochemical systems that function is commonly the concentration of a redox species at the surface of an electrode. For reversible reactions in the absence of uncompensated resistance, complicating homogeneous kinetics or adsorption, Dirichlet boundary conditions of Ox and Red are specified by the applied potential, *E*, according to

$$c_{\text{Ox},x=0} = \frac{\vartheta \left(c_{\text{Ox,bulk}} \left(\frac{D_{\text{Ox}}}{D_{\text{Red}}} \right)^p + c_{\text{Red,bulk}} \right)}{\vartheta \left(\frac{D_{\text{Ox}}}{D_{\text{Red}}} \right)^p + 1}$$

and

$$c_{\text{Red},x=0} = \frac{\left(c_{\text{Ox,bulk}} \left(\frac{D_{\text{Ox}}}{D_{\text{Red}}} \right)^p + c_{\text{Red,bulk}} \right)}{\vartheta \left(\frac{D_{\text{Ox}}}{D_{\text{Red}}} \right)^p + 1},$$

where

$$\vartheta = \frac{c_{\text{Ox},x=0}}{c_{\text{Red},x=0}} = \exp \left[\frac{F}{RT} (E - E_c^{\ominus'}) \right],$$

$E_c^{\ominus'}$ is the → *formal potential*, $c_{\text{Ox,bulk}}$, $c_{\text{Red,bulk}}$, $c_{\text{Ox},x=0}$ and $c_{\text{Red},x=0}$ are the bulk and surface concentrations of Ox and Red, *F* is Faraday’s constant, *R* is the gas constant, *T* is the temperature (K), D_{Ox} and D_{Red} are the diffusion coefficients of Ox and Red, and $p = 1/2$ for semi-infinite linear diffusion in the absence of hydrodynamics, $p = 1$ for steady-state at small electrodes in the absence of hydrodynamics, and $p = 2/3$ for steady-state at a rotating disk electrode (see → *rotating disk elec-*

trode). Dirichlet conditions for both $c_{\text{Ox},x=0}$ and $c_{\text{Red},x=0}$ will be independent of geometry and hydrodynamics when $D_{\text{Ox}} = D_{\text{Red}}$. Regardless of geometry or diffusion-coefficient values the Dirichlet condition for $c_{\text{Red},x=0}$ is zero when ϑ is very large and the Dirichlet condition for $c_{\text{Ox},x=0}$ is zero when ϑ is very small.

SWF

Discharge rate — In the field of → *batteries*, the pace at which current is extracted from a battery is defined as discharge rate. The discharge rate is expressed in amperes or in C rate, which is expressed as a multiple of the rated capacity in ampere-hours. For example, when a 2 Ah battery is discharged at C rate, the total capacity will be delivered within 1 hour at 2 A. When discharging at 0.5 C rate (C rate means coulombic rate), 2 hours will be required for completely discharging the battery at 1 A. Discharge rate is one of several factors (→ *depth of discharge*, temperature, etc.) that alters the practical → *energy density* and the effective capacity that can be obtained from a battery. Discharging at high C rates reduces the energy density that can be obtained from a battery. In general, discharge at rates higher than C rate, e.g., discharge the battery completely at less than one hour, is considered as high rates. → *Ragone diagram* is a commonly used presentation that characterizes the reduction in the effective capacity with discharge rate (or the power delivery).

Refs.: [i] Linden D (1994) *Handbook of batteries*, 2nd edn. McGraw-Hill, New York, Appendix A; [ii] Dell RM, Rand DAJ (2001) *Understanding batteries*. Royal Society of Chemistry, p 7–19, 132–158

OC

Discharging — Discharging occurs when energy is being supplied by an electrical energy → *accumulator*. In electrochemistry, several energy sources are delivering energy by a discharging process. (i) → *Batteries*: When a battery is delivering energy it is said to be discharging. During the discharging process a spontaneous chemical reaction is taking place between the battery's components. This reaction releases energy in the form of charge (electrons) flow, i.e., electrical → *current*. Theoretically, the discharging ends when all the active materials are consumed. However, practically, the discharge process stops way before the end point of the chemical reaction, at the cut-off voltage of the battery. Battery discharge curves, usually voltage vs. time at constant discharge current or power, constitute one of the most important properties of batteries as demonstrated in figure. Some batteries exhibit flat potential discharge curves (Fig. a), while others may show sloping and even stepwise dis-

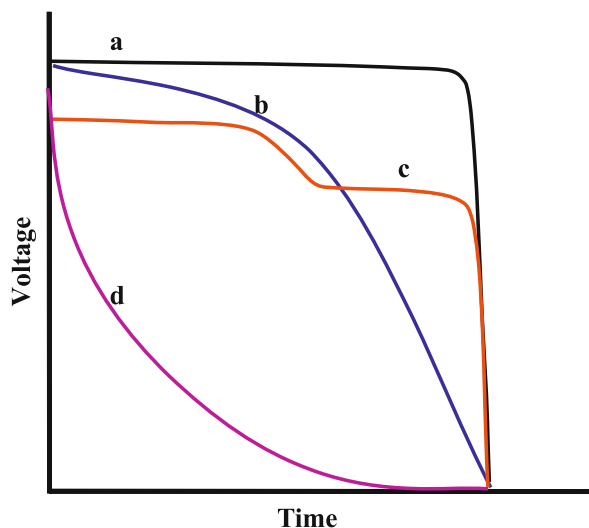

Discharging — Figure. Several types of discharge curves from power sources having the same capacity that were discharged at equal constant currents. a Flat curve; b sloping curve; c stepwise curve; d typical capacitor discharge curve

charge curves (Fig. b, c). (ii) → *Capacitors*: The discharging process in capacitors (both electrochemical and dry) refers to the step in which the charge that was previously stored in the capacitor is being released by producing electrical current. The driving force of discharging is the potential differences between the charged capacitor plates. Initially, there is a large current due to the large potential difference across the plates. The current drops as potential difference drops in an exponential manner, according to the equations: $V_c = V_0 e^{-t/RC}$ (V_0 and V_c are the potential differences at $t = 0$ and at time t , respectively. R and C are the capacitor → *resistance* and → *capacity*). A typical capacitor discharge curve is shown in Fig. d. Rarely, the term ion-discharge is used referring to electrochemical reduction or oxidation of an ion to a neutral molecule in the solution.

Refs.: [i] Crompton TR (2000) *Battery reference book*, 3rd edn. Newness, Oxford, pp 213; [ii] Harmen SL (2002) *Residential construction academy*. Thomson Delmar learning, New York, pp 197–219

OC

Dismutation → *disproportionation*

Dispersion forces → *London forces*, and → *van der Waals forces*

Displacement deposition — Displacement deposition (also called cementation) means the electroless → *deposition* of a noble metal on a less noble metal. The driving

force for the spontaneous process is the difference of the \rightarrow Nernst potentials of the two redox systems. The process is self-limiting because the reaction needs exposed substrate surface to proceed. A well-known example is the cementation of copper on zinc, according to the reaction $\text{Cu}^{2+} + \text{Zn} \rightarrow \text{Cu} + \text{Zn}^{2+}$. A technical application of the cementation is the recycling of precious metals like copper and gold from electronic waste utilizing iron or zinc. To judge which is the noble redox pair one must take into consideration the activities of all involved species. For example, it is possible to electrolessly deposit Sn on Cu in the presence of cyanide. As a complexing agent cyanide shifts the Cu potential towards negative values and thus allows the displacement deposition of Sn on Cu (an important reaction in the printed circuit board industry). In \rightarrow *electrodeposition* processes one often tries to avoid the displacement deposition by preventing direct contact of the anode materials with possible cementation species or by keeping the electrodes under potential control.

Ref.: [i] Paunovic M, Schlesinger M (1998) *Fundamentals of electrochemical deposition*. Wiley, New York, pp 161–166

AB

Disproportionation (or dismutation) — Reaction in which species with the same oxidation state react with each other to yield one species of higher oxidation state and one of lower oxidation state, e.g., $3\text{Au}^+ \rightarrow \text{Au}^{3+} + 2\text{Au}$, or $4\text{KClO}_3 \rightarrow \text{KCl} + 3\text{KClO}_4$, or the d. reaction of an aldehyde in alkaline medium into the respective carboxylic acid and alcohol compounds, known as *Cannizzaro* reaction: $2\text{R}-\text{CHO} + \text{NaOH} \rightarrow \text{R}-\text{COONa} + \text{R}-\text{CH}_2\text{OH}$. In practice, d. happens rarely spontaneously, but is usually achieved by a catalyst application.

The term also applies to an internal oxidation/reduction process as occurs, for example, among the iron atoms of CaFeO_3 , according to: $2\text{Fe}^{4+} \rightarrow \text{Fe}^{(4-\delta)+} + \text{Fe}^{(4+\delta)+}$, at Fe domains on lowering the temperature.

A broader definition of d. includes herein any chemical reaction of the type: $\text{A} + \text{A} \rightarrow \text{A}' + \text{A}''$, where A, A' and A'' are different chemical species, as for example: $2\text{ArH}^+ \rightarrow \text{ArH} + \text{ArH}^{2+}$.

The antonym of d. is comproportionation or synproportionation.

Ref.: [i] Clark JB, Hastie JW, Kihlborg LHE, Metselaar R, Thackeray MM (1994) *Pure Appl Chem* 66:577

MHer

Dissipation — The passage of direct or alternating \rightarrow *current* (or an electromagnetic wave) through a medium is generally accompanied by losses of the elec-

tric (or electromagnetic) energy, due to its gradual transformation into heat. This effect is related to the spatial displacement of charged species inside the medium accompanied by various dissipation processes. The intensity of this energy transformation in the case of AC current is determined by the time-averaged product of the varying components of the potential and the current, $E' \cos \omega t$ and $I' \cos(\omega t + \varphi)$, i.e., only the in-phase component of this product which is proportional to the real part of the complex \rightarrow *impedance*, $Z' = \text{Re}Z$. The relative intensity of the energy losses is characterized by the ratio of in-phase and out-phase components of impedance, Z' and Z'' , respectively, see \rightarrow *dissipation factor*.

MAV

Dissipation factor — Dissipation factor characterizes the ratio of the electric energy transformed to the thermal one, to its conserved part. It is defined as $D = Z'/Z'' = -Y'/Y'' = \epsilon''/\epsilon'$, where $Z' = \text{Re}Z$, $Z'' = \text{Im}Z$, $Y' = \text{Re}Y$, $Y'' = \text{Im}Y$, $\epsilon' = \text{Re}\epsilon$, $\epsilon'' = \text{Im}\epsilon$, i.e., real and imaginary parts of complex \rightarrow *impedance* Z or complex \rightarrow *admittance* Y or complex dielectric function ϵ . The dissipation factor is related to the “quality factor”, Q, the loss angle, δ , and the phase difference (phase shift), φ : $D = Q^{-1} = \tan \delta = \cot \varphi$ (see also \rightarrow *impedance*).

Ref.: [i] Retter U, Lohse H (2005) *Electrochemical impedance spectroscopy*. In: Scholz F (ed) *Electroanalytical methods*. Springer, Berlin

MAV

Dissociation — is the separation or splitting of a chemical compound (complexes, molecules, or salts) into two or more \rightarrow *ions* by dissolution and \rightarrow *solvation*, or by any other means, the breaking into smaller molecules, or radicals. In case of solvation, this results in an ionically conducting \rightarrow *electrolyte* solution. D. usually occurs in a reversible manner. The opposite process is association or recombination. Assuming a reversible dissociation reaction in a chemical \rightarrow *equilibrium* of the form $\text{XY} \rightleftharpoons \text{X} + \text{Y}$, the ratio of dissociation is quantified by the dissociation constant K_D , i.e.: $K_D = \frac{a_X a_Y}{a_{XY}}$ where a denotes the activity of the species. The dissociation constants are frequently quoted as values of $\text{p}K_D = -\log K_D$. In mass spectrometry, the term is used in the meaning of a fragmentation, i.e., a decomposition of an ion into another ion of lower mass and one or more neutral species.

Refs.: [i] Todd JF (1991) *Pure Appl Chem* 63:1541; [ii] *Dissociation constants of inorganic acids and bases*. In: Lide DR (ed) (2003) *CRC handbook of chemistry and physics*, 84th edn. CRC Press, Boca Raton, pp 8–44 – 8–45; [iii] *Dissociation constants of organic acids and bases*. In: Lide DR (ed) (2003) *CRC handbook of chemistry and physics*, 84th edn. CRC

Press, Boca Raton, pp 8–46 – 8–56; [iv] Dean JA (1992) *Lange's handbook of chemistry*, 14th edn. McGraw-Hill, New York, pp 8–13 – 8–71

MHer

D

Dissociation mechanism (mechanism of response of the glass electrode) → *glass electrode*

Distonic radical cation — is a radical cation in which charge and radical sites are separated, for instance, $\dot{\text{C}}\text{H}_2(\text{CH}_2)_n\text{NH}_2^+$. Distonic radical cations are more stable than their conventional isomers $\text{CH}_3(\text{CH}_2)_n\text{NH}_2^+$. With the increase of n the energy difference converges to a limit which is close to the energy difference between the component systems $\text{CH}_3\dot{\text{C}}\text{H}_2 + \text{CH}_3\text{NH}_3^+$ (representing the distonic isomer) and $\text{CH}_3\text{CH}_2 + \text{CH}_3\text{NH}_2^+$ (representing the conventional isomer). The term ylidion describes the subclass of distonic radical cations in which the charge and radical sites are on adjacent centers, e.g., methyleneoxonium radical cation, $\dot{\text{C}}\text{H}_2\text{OH}_2^+$.

Ref.: [i] Yates BF, Bouma WJ, Radom L (1986) *Tetrahedron* 42:6225

WK

Distribution (Nernst) potential → *potential*

Divided cells — Electrochemical cells divided by sintered glass, ceramics, or ion-exchange membrane (e.g., → *Nafion*) into two or three compartments. The semipermeable separators should avoid mixing of → *anolyte* and → *catholyte* and/or to isolate the reference electrode from the studied solution, but simultaneously maintain the cell resistance as low as possible. The two- or three-compartment cells are typically used a) for preparative electrolytic experiments to prevent mixing of products and intermediates of anodic and cathodic reactions, respectively; b) for experiments where different composition of the solution should be used for anodic and cathodic compartment; c) when a component of the reference electrode (e.g., water, halide ions etc.) may interfere with the studied compounds or with the electrode. For very sensitive systems additional bridge compartments can be added.

Ref.: [i] Sawyer DT, Sobkowiak A, Roberts JL, Jr (1995) *Electrochemistry for chemists*, 2nd edn. Wiley, New York, pp 249

JL

DLVO theory (Derjaguin–Landau–Verwey–Overbeek theory) — The DLVO theory is named after Derjaguin and Landau [i], and Verwey and Overbeek [ii]. It describes the forces acting between colloidal particles in

ionic solutions. The theory builds on an idea of → *Chapman* [iii], who assumed that, everywhere throughout an ionic solution, the local concentration of electrolyte ions was determined by the local time-averaged value of the electric potential $\langle V(r) \rangle$ according to a Boltzmann-like formula. Thus, the local population of ions of species i was assumed to take the form

$$n_i(r) = n_i^0 \exp\left(-\frac{\Delta G_i}{kT}\right)$$

so that

$$n_i(r) = n_i^0 \exp\left(-\frac{ez_i\langle V(r) \rangle}{kT}\right),$$

where ΔG_i is the molar → *Gibbs energy* of the ionic species i , $n_i(r)$ is the concentration of the ionic species i at location r , n_i^0 is the concentration of ionic species i far from the reactant, e is the unit charge on the electron (→ *elementary electric charge*), z_i is the valence of the ionic species i , k is the → *Boltzmann constant*, T is the absolute temperature, and $\langle V(r) \rangle$ is the time-averaged value of the electric potential at location r . The Chapman model works reasonably well, at least at low concentrations (<0.01 M). Assuming that there are only two types of ions, having equal and opposite valences (z_+ and z_-), one finds

$$\begin{aligned} \sum_i^N ez_i n_i(r) &= ez_+ n_+(r) - ez_- n_-(r) \\ &= ez_i n_i^0 \left[\exp\left(-\frac{ez_i\langle V(r) \rangle}{kT}\right) - \exp\left(+\frac{ez_i\langle V(r) \rangle}{kT}\right) \right] \\ &= -2ez_i n_i^0 \sinh\left(\frac{ez_i\langle V(r) \rangle}{kT}\right). \end{aligned}$$

Hence

$$\nabla^2 \langle V(r) \rangle = \frac{2ez_i n_i^0}{\epsilon_r \epsilon_0} \sinh\left(\frac{ez_i\langle V(r) \rangle}{kT}\right),$$

where ϵ_r is the relative → *permittivity* (static dielectric constant) of the solution, ϵ_0 is the permittivity of free space, and $e/kT = F/RT = 25.7$ mV at room temperature. This nonlinear partial differential equation in $\langle V(r) \rangle$ is very well known and is called the → *Poisson–Boltzmann equation*. But it is very badly named. Neither Poisson nor Boltzmann advocated it, and neither lived to see it! Still, it is the equation that needs to be solved. Despite all the simplifications used in its derivation, no

general solution of the Poisson–Boltzmann equation has ever been found. Indeed, only the particular case of planar coordinates has been solved exactly, by Chapman himself, yielding his celebrated formula for the diffuse layer capacitance of a planar electrode

$$C_{\text{DIFF}} = A \left(\frac{2\varepsilon_r \varepsilon_0 e^2 z_i^2 n_i^0}{kT} \right)^{1/2} \cosh \left(\frac{ez \langle V \rangle}{2kT} \right).$$

To make headway with the colloidal problem, the Poisson–Boltzmann equation must be solved in spherical coordinates. → Debye and → Hückel [iv] introduced the following approximation into the spherical case,

$$\sinh \left(\frac{ez_i \langle V(r) \rangle}{kT} \right) \approx \frac{ez_i \langle V(r) \rangle}{kT}.$$

This transformed the nonlinear Poisson–Boltzmann equation into the linear Helmholtz-type equation

$$\nabla^2 \langle V(r) \rangle \approx \kappa^2 \langle V(r) \rangle,$$

where κ was the reciprocal → Debye length

$$\kappa = \left(\frac{2e^2 z_i^2 n_i^0}{\varepsilon_r \varepsilon_0 kT} \right)^{1/2}.$$

Based on this idea, Derjaguin and Landau, and Verwey and Overbeek, found the pair potential for the electrostatic repulsion of two identical spherical particles in an electrolyte solution to be

$$U_1(x) = \frac{(Ze)^2}{\varepsilon_r \varepsilon_0} \left[\frac{e^{\kappa a}}{1 + \kappa a} \right]^2 \frac{e^{-\kappa x}}{x},$$

where (Ze) is the effective surface charge on the particles, e is the unit charge on the electron, ε_r is the relative permittivity (static dielectric constant) of the solution, ε_0 is the permittivity of free space, κ is the reciprocal Debye length (determined by the electrolyte concentration), a is the radius of the spheres, and x is the center-to-center distance between the spheres. The full DLVO pair potential can also be extended to take into account an attractive van der Waals term $U_2(x)$, so that

$$U_{\text{DLVO}} = U_1(x) + U_2(x),$$

where

$$U_2 = -\frac{A_H}{6} \left[\frac{2a^2}{r^2 - 4a^2} + \frac{2a^2}{r^2} + \ln \left(\frac{r^2 - 4a^2}{r^2} \right) \right]$$

and A_H is the → Hamaker constant. The van der Waals term creates a minimum in U_{DLVO} at very small interparticle separations [v]. However, in many practical applications this can be ignored.

Refs.: [i] Derjaguin B, Landau L (1941) *Acta Physicochim URSS* 14:633; [ii] Verwey EJJW, Overbeek JTG (1948) *Theory of the stability of lyophobic colloids*. Elsevier, New York; [iii] Chapman DL (1913) *Philos Mag* 25:475; [iv] Debye P, Hückel E (1923) *Phys Z* 24:185; [v] Lyklema J (1991) *Fundamentals of interface and colloid science*. Academic Press, New York

SF

DMFC → direct methanol fuel cell

DN → donor number

DNA biosensors — Wide-scale DNA testing requires the development of small, fast, and easy-to-use devices. DNA → biosensors, based on nucleic acid recognition processes, have been developed towards the goal of rapid, simple and inexpensive testing of genetic and infectious diseases, and for the detection of DNA damage and interactions. DNA hybridization biosensors commonly rely on the immobilization of a single-stranded (ss) oligonucleotide probe onto a transducer surface to recognize – by hybridization – its complementary target sequence. The binding of the surface-confined probe and its complementary target strand is translated into a useful electrical signal.

Electrochemical devices have proven very useful for sequence-specific biosensing of DNA. Electrochemical detection of DNA hybridization usually involves monitoring a current response under controlled potential conditions. The hybridization event is commonly detected via the increased current signal of a redox indicator (that recognizes the DNA duplex) or from other hybridization-induced changes in electrochemical parameters (e.g., conductivity or capacitance). Modern electrical DNA hybridization biosensors and bioassays offer remarkable sensitivity, compatibility with modern microfabrication technologies, inherent miniaturization, low cost (disposability), minimal power requirements, and independence of sample turbidity or optical pathway. Such devices are thus extremely attractive for obtaining the sequence-specific information in a simpler, faster, and cheaper manner, compared to traditional hybridization assays.

The probe immobilization step plays a major role in the overall performance of electrochemical DNA biosensors. The probes are typically short oligonucleotides (25–50 mer) that are capable of hybridizing with specific and unique regions of the target nucleotide sequence. Control of the surface chemistry and coverage is essential for assuring high reactivity, orientation/accessibility, and stability of the surface-bound probe, as well as for avoiding nonspecific bind-

ing/adsorption events, and hence for meeting the high sensitivity and selectivity demands.

Other modes of DNA interactions (besides base-pair recognition) have been used for the development of electrochemical DNA biosensors. In particular, dsDNA-modified electrodes can be designed for detecting small molecules (e.g., drugs or carcinogens) interacting with the immobilized nucleic-acid layer, or for detecting DNA damage. The latter commonly reflects the fact that the electrochemical response of DNA is strongly dependent on the DNA structure.

Refs.: [i] Palecek E, Fojta M (2001) *Anal Chem* 73:75A; [ii] Wang J (2000) *Nucleic Acids Res* 28:3011; [iii] Gooding JJ (2002) *Electroanalysis* 14:1149

JW

DOD → depth of discharge

Dogonadze, Revaz (Rezo) Romanovich



(Courtesy of Prof. Z.D. Urushadze)

(Nov. 21, 1931, Tbilisi, Georgia, USSR – May 13, 1985) Dogonadze was one of the founders of the new science – electrochemical physics [i]. The main scientific interests of Dogonadze were focused on condensed-phase reactions. His pioneering works of 1958–59 have laid the foundations of the modern quantum-mechanical theory of elementary chemical processes in electrolyte solutions. He developed a comprehensive quantum-mechanical theory of the elementary act of electrochemical reactions of → *electron* and → *proton transfer* at metal and → *semiconductor electrodes* [ii–v]. He was the first to obtain, by a quantum-mechanical calculation, the expression for the electron transfer probability, which was published in 1959 in his work with → *Levich*. He conducted a number of studies on the theory of low-velocity electrons in disordered systems, theory of solvated electrons, and theory of photochemical processes in solutions. He made an impressive contribution to the theory of elementary biochemical processes [vi]. His work in this area has led to the foundation of the theory of low-temperature → *charge-transfer processes* cov-

ering not only tunnel processes in biochemical and electrochemical systems, but also tunnel transport of atoms and defects in solids.

Refs.: [i] Grafov BM, Krishtalik LI, Kuznetsov AM (2003) *Russian J Electrochem* 39:1; [ii] Dogonadze RR, Kuznetsov AM (1975) *Prog Surf Sci* 6:1; [iii] Dogonadze RR (1971) *Theory of molecular electrode kinetics*. In: Hush NS (ed) *Reactions of molecules at electrodes*. Interscience, London, pp 135–227; [iv] Dogonadze RR, Kuznetsov AM, Marsagishvili TA (1980) *Electrochim Acta* 25:1; [v] Dogonadze RR, Kuznetsov AM (1983) *Quantum electrochemical kinetics: Continuum theory*. In: Conway BE, Bockris JO'M, Yeager E (eds) *Comprehensive treatise of electrochemistry*, vol. 7. Plenum Press, New York, pp 1–40; [vi] Dogonadze RR, Kuznetsov AM, Ulstrup J (1977) *J Theor Biol* 69:239

EK

Donicity → donor number

Donnan, Frederick George



(Reproduced courtesy of the Library and Information Center of the Royal Society of Chemistry)

(Sep. 5, 1870, Colombo, Ceylon (British Empire), now Sri Lanka – Dec. 16, 1956, Canterbury, Kent, UK). Donnan was a British chemist who greatly contributed to the development of colloid chemistry, physical chemistry, and electrochemistry [i–iii]. In different periods of his life, he was working with van't Hoff, → *Ostwald*, F.W., and Ramsay. In electrochemistry, he studied (1911) the electrical potential set-up at a semipermeable membrane between two electrolytes [iv], an effect of great importance in living cells [v]. Donnan is mostly remembered for his theory of membrane equilibrium, known as → *Donnan equilibrium*. This equilibrium results in the formation of → *Donnan potential* across a membrane.

Refs.: [i] Freeth FA (1957) *Biographical memoirs of fellows of the Royal Society* 3:23; [ii] Freeth FA (1961) *J Am Chem Soc* 83:2979; [iii] Taylor H (1962) *Colloid Polym Sci* 183:81; [iv] Donnan FG (1911) *Z Elektrochem* 17:572; [v] Fuhrman FA (1959) *Annu Rev Physiol* 21:19

EK

Donnan equilibrium — originates from different permeability of cations and anions through a semipermeable membrane (because one of the ionic species is too

large to pass through the pores of the membrane), thus resulting in the formation of the → *Donnan potential*. The membrane may be replaced by other kinds of restraint (e.g., field of gravity), which prevent some ionic components from moving from one phase to another.

Ref.: [i] Bockris JO'M, Reddy AKN, Gamboa-Aldeco M (2000) *Modern electrochemistry. Electroics in chemistry, engineering, biology, and environmental science*, vol. 2B, 2nd edn. Kluwer, New York, p 1914

EK

Donnan potential — is the → *Galvani potential difference* between two solutions separated by an → *ion-exchange membrane* in the absence of any current flowing through the membrane. This potential originates from the different distribution of cations and anions on both sides of the semipermeable membrane. See also → *potential*.

Refs.: [i] Bockris JO'M, Reddy AKN, Gamboa-Aldeco M (2000) *Modern electrochemistry. Electroics in chemistry, engineering, biology, and environmental science*, vol. 2B, 2nd edn. Kluwer, New York, p 1914; [ii] Bolam TR (1932) *The Donnan equilibria and their application to chemical, physiological and technical processes*. G Bell, London (German ed: Bolam TR (1934) *Die Donnan-Gleichgewichte*. Th Steinkopf, Dresden)

EK

Donor number (or donicity), DN — is an empirical semiquantitative measure of nucleophilic properties (→ *acid-base theories*, subentry → *Lewis acid-base theory*) of a solvent defined as the negative of the standard molar heat of reaction (expressed in kcal mol⁻¹) of the solvent D with antimony pentachloride to give the 1:1 adduct, when both are in dilute solution in the inert diluent 1,2-dichloroethane, according to the reaction scheme:

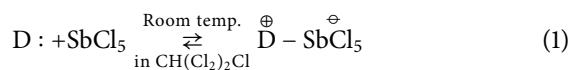

DN is determined calorimetrically. See also → *acceptor number*.

Ref.: [i] Gutmann V, Vychera E (1966) *Inorg Nucl Chem Lett* 2:257

WK

Doping — is the controlled addition of a relatively small amount of foreign component (dopant) to solid materials in order to change their properties, or the process of adding impurity atoms. As a rule, dopant ions or atoms are incorporated into the crystal lattice of host material. The dopant ions are often considered as point defects (see → *defects in solids*). Depending on the type of host lattice and dopant, the incorporation of foreign species may lead to creation of → *electronic defects*, other point

defects, and defect clusters. This effect is widely used for the optimization of semiconductors and solid electrolytes (see → *stabilized zirconia* and → *cerium dioxide*). The term “doping” is also incorrectly used in the field of → *conducting polymers*, describing the incorporation of ions (counter ions) into the polymer phase (layer, film) by oxidizing or reducing the polymer.

Refs.: [i] West AR (1984) *Solid state chemistry and its applications*. Wiley, Chichester; [ii] Smart LE, Moore EA (2005) *Solid state chemistry: An introduction*. CRC Press/Taylor & Francis, Boca Raton

VK

Dorn effect → *Dorn potential*, and → *sedimentation potential*

Dorn potential — Potential difference established during sedimentation of charged particles (see → *sedimentation potential*).

RH

Double layer — In general, a double layer of charges exists at the interface between two conducting media: One side carries a positive excess → *charge*, which is balanced by a negative excess of equal magnitude on the other side. The resulting potential drop across the interface is the double-layer potential. Two limiting cases exist: at an ideally polarizable → *interface* the two adjacent phases cannot exchange charges; the system then behaves like a capacitor, which can be charged by applying an external potential. At an ideally nonpolarizable interface the two phases can exchange charge carriers, ions or electrons, and in the stationary case the potential difference is determined by the difference of the → *chemical potential* of these carriers in the two phases.

Refs.: [i] Lipkowski J, Ross PN (eds) (1993) *Structure of electrified interfaces*. VCH, New York; [ii] Bockris JO'M, White RE, Conway BE (eds) (1980) *Comprehensive treatise of electrochemistry*, vol. 1. Plenum Press, New York

WS

Double-layer capacity (Capacitance) — The → *excess charge* stored on both sides of the double layer depends on the → *electrode potential*, therefore the double layer can be represented by a capacitor in equivalent circuits. In general, this capacitor is nonlinear, i.e., the stored charge is not proportional to the potential. Hence two different capacities can be defined:

differential capacity — $C = \frac{dQ}{dE}$, where Q is the excess → *charge* stored on the electrode, and E the electrode potential; the differential capacity is easy to measure, for example by → *impedance spectroscopy*. This is

the commonly used definition for the capacity. In general, C depends on the electrode potential E , and in impedance spectroscopy also on the frequency ν ; often, a frequency near $\nu = 20$ Hz is used as a reference, since in this range interference from other processes is small.

integral capacity — $C_{\text{int}} = \frac{Q}{E - E_{\text{pzc}}}$, where E_{pzc} is the \rightarrow potential of zero charge of the electrode. This quantity is rarely used, since it carries less information than the differential capacity, and it requires a separate determination of the \rightarrow potential of zero charge.

Double layer, diffuse double layer, or Gouy–Chapman layer — That part of the double layer which is adequately described by the Gouy–Chapman theory. Details can be found under \rightarrow double layer models. See also \rightarrow Gouy, \rightarrow Chapman.

See also \rightarrow diffuse double-layer capacitance.

Double layer, excess charge density — The charge density per unit area that resides on the electrode surface. It is defined as the excess of the atomic charge over the electronic charge per unit area. For the case in which the electrode contains only one kind of atoms, the definition is: $\sigma = ze_0\Gamma_M - e_0\Gamma_e$, where Γ_M is the surface excess of the atoms of the electrode, and z is their charge number; e_0 is the unit of charge (\rightarrow elementary electric charge), and Γ_e the surface excess of electrons. The excess charge on the electrode is balanced by a corresponding excess in the solution: $\sigma = -\sum_i z_i e_0 \Gamma_i$ where the sum is over all ionic species i with charge number z_i and surface excess Γ_i in the solution.

Double layer, Helmholtz layer, Helmholtz plane — These terms are based on a simple geometric model of the interface. One distinguishes between an inner and an outer Helmholtz layer. The **inner Helmholtz layer** comprises all species that are specifically adsorbed on the electrode surface. If only one type of molecule or ion is adsorbed, and they all sit in equivalent positions, then their centers define the **inner Helmholtz plane**. The **outer Helmholtz layer** comprises the ions that are closest to the electrode surface, but are not specifically adsorbed. They have kept their \rightarrow solvation spheres intact, and are bound only by electrostatic forces. If all these ions are equivalent, their centers define the **outer Helmholtz plane**.

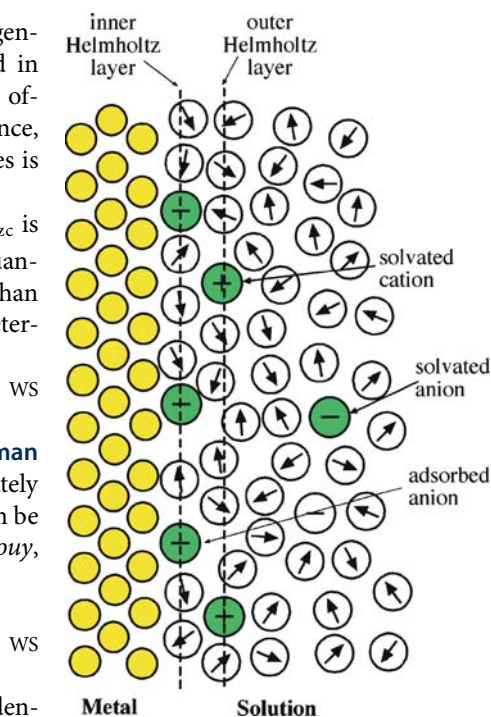

Double layer, Helmholtz layer, Helmholtz plane — Figure

Double layer models — The oldest model for the double layer at metal/solution interfaces was proposed by \rightarrow Helmholtz. He suggested that an excess charge (\rightarrow double layer, excess charge density) on the metal attracts an equivalent amount of counter ions to the interface, the two opposing layers are separated by a certain distance, which determines the capacity. His model gave rise to the concepts of the inner and outer Helmholtz planes (layers) (\rightarrow Double layer).

\rightarrow Gouy and \rightarrow Chapman proposed the first statistical model: By combining electrostatics with Boltzmann statistics, they derived the \rightarrow Poisson–Boltzmann equation for the distribution of ions in the solution. For planar geometry, and for an electrolyte containing two kinds of ions with opposite charge numbers, this can be solved exactly. This Gouy–Chapman theory is equivalent to the \rightarrow Debye–Hückel theory, which it preceded by several decades. It is valid at low electrolyte concentrations in the vicinity of the point of zero charge. In particular, it predicts that the capacity attains its minimum at this point.

For higher concentrations, and far from the point of zero charge, the Gouy–Chapman theory predicts interfacial capacities that are much higher than the experimental values. To explain these findings, Stern combined

the ideas of Helmholtz, Gouy, and Chapman into what is known as the Gouy–Chapman–Stern model, which is meant to describe the interface in the absence of specific adsorption. In this model the ions can approach the electrode surface only up to the outer Helmholtz plane; in this context, the outer Helmholtz layer is also known as the Stern or ion-free layer. Mathematically, the interface can then be described as two capacitors in series: $1/C = 1/C_H + 1/C_{GC}$. The first term is known as the Helmholtz or inner layer capacity; this equation also forms the basis of the \rightarrow *Parsons and Zobel plot*. At high concentrations and charge densities, the Helmholtz capacity, which is independent of the ionic concentration, dominates. The variation of the dielectric \rightarrow *permittivity* of the solvent in the double layer was considered in the Bockris–Devanathan–Müller model.

In the Gouy–Chapmann theory the electrolyte is described as point ions in a dielectric continuum. The hard-sphere electrolyte model constitutes a significant advance; here the ions and solvent molecules are described as hard spheres with a charge resp. with a point dipole at their center. The statistical mechanics of this model have been solved in the vicinity of the point of zero charge in the so-called mean spherical approximation. Due to the layering of the hard spheres near the metal surface, the electrostatic potential exhibits oscillations. Formally, the interfacial capacity can again be described as two capacitors in series, but the term corresponding to the Helmholtz capacity is caused by an extended boundary layer rather than by a single Helmholtz layer. This model permits the calculation of the capacity from the radii of the spheres and from the dipole moment of the solvent. Reasonable estimates of these quantities for aqueous solution result in interfacial capacities that are too small by a factor of two to three compared with experimental values.

The double-layer capacity depends strongly on the nature of the electrode material, even in cases where there is no specific adsorption of ions and solvent. It was therefore suggested, first by O.K. Rice, that the metal makes a direct contribution to the double-layer capacity. This idea was quantitatively pursued within the \rightarrow *jellium model*, in which the distribution of the electrons at the surface is affected by the double-layer field. In essence, the surface electrons form a highly polarizable medium, which enhances the capacity. In combination with the hard sphere electrolyte model, it gives the correct order of magnitude for the capacity at the \rightarrow *point of zero charge*; also, it predicts correctly that the capacity of simple sp-metals should increase with the electronic density. An extension of the jellium-hard sphere elec-

trolyte model to metals containing d-bands and beyond the point of zero charge has not yet been achieved.

Much recent work on double-layer models has been based on computer simulations, while these have given further insight into the distribution of particles for specific cases, they have not contributed new concepts or given quantitative results.

Refs.: [i] von Helmholtz H (Nov 1881) *Monatsber Preuss Akad Wiss*; [ii] Gouy A (1909) *Compt Rend* 149:654; [iii] Chapman DL (1913) *Philos Mag* (6) 25:475; [iv] Carnie SL, Chan DYC (1980) *J Chem Phys* 73:2949; [v] Blum L, Henderson D (1981) *J Chem Phys* 74:1902; [vi] Rice OK (1928) *Phys Rev* 31:105; [vii] Schmickler W, Henderson D (1986) *Prog Surf Sci* 22:323; [viii] Guidelli R, Schmickler W (2000) *Electrochim Acta* 45:2317
WS

Double layer, effect on charge transfer rate — At the interface, the concentration of charged reactants is affected by the charge on the electrode surface. Thus, a negatively charged reactant will be repelled from a negatively charged surface. Therefore, the interfacial concentration may deviate significantly from the bulk value. At low electrolyte concentration, the magnitude of this so-called \rightarrow *Frumkin effect* can be estimated from \rightarrow *Gouy–Chapman theory*.

Ref.: [i] Frumkin AN (1933) *Z phys Chem* 164A:121

WS

Double-step chronocoulometry \rightarrow *chronocoulometry*

GI

Dow, Herbert Henry



(Feb. 26, 1866, Belleville, Ontario, Canada – Oct. 16, 1930, Rochester, Minn, USA) Dow graduated at the Case School of Applied Science (now Case Western Reserve University). During his undergraduate chemistry project he discovered that Michigan brines were unusually rich in bromine. In 1890 he established Midland Chemical Company to produce bromine from

brine. The Dow process was the first commercial process for the production of bromine by \rightarrow *electrolysis*. He also applied electrolysis to produce sodium hydroxide and chlorine from sodium chloride. In 1895 he formed the Dow Chemical Company. Taking advantage of the opportunity during World War I – when import from Germany was blocked – Dow produced massive amounts of bromine, chlorine, sulfur chloride, monochlorobenzene, phenol, magnesium, and synthetic indigo. It helped the development of the company which became the fifth largest chemical company in the world that sells more than 2000 chemicals and plastic products around the globe. Photo was taken from Ref. [i].

Refs.: [i] <http://www.chemheritage/eminentchemists/HHDow/HerbertDow.htm>; [ii] Whitehead D (1983) *The Dow story: the history of Dow Chemical Company*, McGraw–Hill, New York

GI

Dow–Huron cell — Electrochemical cell for hydrogen peroxide production. A diaphragm-divided cell employing a carbon chips-PTFE composite as cathode material fed with air. At the anode oxygen is developed at, e.g., a platinized titanium electrode.

Ref.: [i] Pletcher D, Walsh FC (1993) *Industrial electrochemistry*. Blackie Academic & Professional, London

RH

Downs cell — Cell designed for the \rightarrow *electrolysis* of molten NaCl (Downs process). In a steel container lined with ceramic tiles a cast iron cathode and a graphite anode are immersed in the molten salt. A diaphragm keeps chlorine gas from reaching the liquid sodium. In order to operate the electrolyzer at moderated temperatures (the melting temperature of NaCl is $T_m = 801\text{ }^\circ\text{C}$) CaCl_2 and BaCl_2 are added resulting in an operating temperature $T = 600\text{ }^\circ\text{C}$. The sodium is always contaminated with traces of calcium.

Ref.: [i] Pletcher D, Walsh FC (1993) *Industrial electrochemistry*. Blackie Academic & Professional, London

RH

DRAM (dynamic random access memory) — A type of a commonly used random access memory that allows the stored data to be accessed in any order, i.e., at random, not just **in sequence**. That type of computer memory stores each **bit** of data in a separate capacitor charged and discharged by only one logic element transistor. However, the DRAM capacitors are not ideal and hence leak electrons; the information eventually fades unless the capacitor charge is periodically refreshed (circa every 64 ms). This makes this type of memory more power

consuming. Because of the refresh requirement, DRAM is a dynamic memory as opposed to **SRAM** (Static Random Access Memory) and other static memories. Its advantage over SRAM is its structural simplicity: only one transistor and one capacitor are required per one bit of information, compared to six transistors in SRAM. This allows the DRAM memories to reach a very high density. A serious disadvantage of the DRAM modules is the loss of the data when the power supply decays.

Modern DRAM-capacitor dimensions are less than $1\text{ }\mu\text{m}$, the capacities are lower than 10^{-15} F , and the collected electrical charge is usually lower than one million of electrons.

Ref.: [i] Stallings W (2005) *Computer organization and architecture: Design for performance*, 7th edn. Prentice Hall, chap 5

MD

Drop time method \rightarrow *drop weight method*

Drop weight method — Method to determine the \rightarrow *interfacial tension* in liquid–gas and liquid–liquid systems [i]. When a liquid is dispensed by gravity from a tube with a circular orifice with radius r , the weight of the drops w_{drop} depends on the interfacial tension γ as follows: $w_{\text{drop}} = m_{\text{drop}}g = 2\pi r\gamma$ (Eq. 1) (m_{drop} is the mass of a drop, g is the constant of gravitational acceleration). This equation is known as Tate’s law [ii]. Alternatively to weighing the drops, one can measure the drop time, for which follows: $t_{\text{drop}} = 2\pi r\gamma/fg$ (Eq. 2) (f is the constant volume flow rate). Equations 1 and 2 are not exact and a number of corrections have been published [iii–v]. However, it is common practice to use correction factors and calibrate the method with liquids of known interfacial tension. \rightarrow Kučera applied the drop time method to the \rightarrow *dropping mercury electrode* to measure the potential dependence of interfacial tension. The anomalies observed were studied by \rightarrow Heyrovský and led to the development of \rightarrow *polarography*.

See also \rightarrow *electrocapillarity*, \rightarrow *electrocapillary curve*, \rightarrow *Gibbs–Lippmann equation*, \rightarrow *Wilhelmy plate (slide) method*, \rightarrow *ring method*, \rightarrow *Lippmann capillary electrometer*.

Refs.: [i] Adamson AW, Gast AP (1997) *Physical chemistry of surfaces*, 6th edn. Wiley, New York, pp 19; [ii] Tate T (1864) *Philos Mag* 27:176; [iii] Rayleight JWS (1899) *Philos Mag* 48:321; [iv] Harkins WD, Brown FE (1919) *J Am Chem Soc* 41:499; [v] Albert HF, Scholz F (1987) *J Electroanal Chem* 235:107

FS

Droplets, electrochemistry of immobilized \sim — Technique for studying the electrochemical reactions at

→ *three-phase boundaries* [i], i.e., when droplets of a liquid are attached to a solid electrode that is immersed into another liquid that is immiscible with the droplet-phase. The three-phase arrangement allows performing a simultaneous electron and ion transfer reactions, giving access to the → *Gibbs energies of ion transfer*: A droplet of a solution of an electroactive and lipophilic compound is dissolved in a water-immiscible liquid and the droplet is attached to the surface of a working electrode, e.g., a → *paraffin-impregnated graphite electrode*. The Figure depicts the coupled electron and ion transfer reactions for the example of decamethylferrocene (dmfc). The overall process occurring at the three-phase electrode can be described by the following reaction scheme:

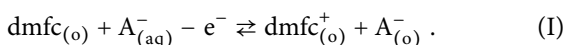

The thermodynamic treatment to the reaction scheme (I), leads to the following equation [ii, iii]:

$$E_c^{\ominus'} = E_{\text{dmfc}_{(org)}^+ | \text{dmfc}_{(org)}}^{\ominus} + \frac{\Delta_{\text{W}}^{\text{org}} G_{\text{A}^-}^{\ominus}}{F} - \frac{RT}{F} \ln(c_{\text{A}_{(w)}^-}) + \frac{RT}{F} \ln\left(\frac{c_{\text{dmfc}_{(org)}}}{2}\right) . \quad (\text{I})$$

Similarly, the reduction of an *electroreducible* lipophilic compound will provoke the transfer of cations from the aqueous to the organic phase:



The thermodynamic treatment of the reaction given in Eq. (2) leads to the following form of the → *Nernst equation*, Eq. (2) [i]:

$$E_c^{\ominus'} = E_{\text{Ox}_{(org)}^- | \text{Red}_{(org)}^-}^{\ominus} - \frac{\Delta_{\text{W}}^{\text{org}} G_{\text{Cat}^+}^{\ominus}}{F} + \frac{RT}{F} \ln(c_{\text{Cat}_{(w)}^+}) + \frac{RT}{F} \ln\left(\frac{2}{c_{\text{Ox}_{(org)}}}\right) . \quad (\text{2})$$

Various mechanistic studies concerning the electrochemistry of redox active liquids have been reported by Marken and Compton et al. [iv, v].

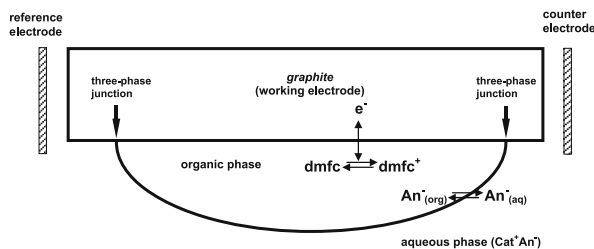

Droplets, electrochemistry of immobilized ~ Figure. Scheme of the processes taking place at a three-phase electrode

Refs.: [i] Scholz F, Schröder U, Gulaboski R (2005) *Electrochemistry of immobilized Particles and droplets*. Springer, Berlin, pp 183–253; [ii] Scholz F, Komorsky-Lovrić Š, Lovrić M (2000) *Electrochem Commun* 2:112; [iii] Scholz F, Gulaboski R (2005) *ChemPhysChem* 6:16; [iv] Banks CE, Davies TJ, Evans RG, Hignett G, Wain AJ, Lawrence NS, Wadhawan JD, Marken F, Compton RG (2003) *Phys Chem Chem Phys* 5:4053; [v] Davies TJ, Banks CE, Compton RG (2005) *J Solid State Electrochem* 9:797

RG

Dropping mercury electrode (DME) — Polarizable electrode formed by sequence of mercury drops falling from a small aperture. After its first description in 1871 [i] it was explored by many authors in connection with development of the concept of → *electrode potential* [ii]. In that way it represented a scientific problem, and only after 30 years it was first used as a scientific tool [ii]. At that time the DME was mostly formed at the end of a narrow glass capillary connected by elastic tubing with a reservoir of mercury. By changing the height of mercury level in the reservoir above the orifice of the capillary the time of formation of the drop was usually adjusted to several seconds. With radius of the orifice of the capillary of less than 0.2 mm the shape of the drop is strictly spherical. Such DME is then characterized by two parameters: rate of flow of mercury m (in grams per second) and drop-time t_1 (in seconds). Its weight w can then be expressed thus: $w = mt_1g = 2\pi r\gamma$, where g is gravitational constant (980.67 cm per s^2), π is 3.14, r is radius of the orifice of the capillary (in cm), and γ is surface or interfacial tension (in dynes per cm). On the basis of this relation → *Kučera* introduced a method of determining interfacial tension between polarized mercury, and a solution by measuring drop-weight or drop-time [ii], later I. Oref [iii] used DME for studying the adsorption from the gas phase. – Mercury as electrode material (→ *mercury, and mercury electrodes*) has specific advantages: a) it has of all metals the highest → *hydrogen overpotential*, which enables polarization of the electrode to fairly negative potentials; b) the surface of mercury drops is homogeneous and isotropic, allowing sensitive and precise study of adsorption; in addition, DME has special features: c) periodic renewal of ideal liquid surface, unaffected by preceding events, which leads to reproducible results in electrolytic measurements irrespective of direction of polarizing scan; d) the small size of the mercury drop guarantees negligible consumption of electroactive species during electrolysis, which is the condition of quantitative reproducibility of electrolytic measurements. Aware of these advantages → *Heyrovský J* used DME for electrolysis [iv], which developed into

→ *polarography* [v]. As the surface of DME keeps changing in time, the first polarographs were recording the mean value of current flowing during the whole drop-life. In equations expressing different types of currents in → *polarography* the terms m and t_1 always appear, characterizing the particular DME used; the values of m should be always less than 2 mg/s, which guarantees that the flow of mercury into the drop remains laminar. Faster flow causes inner turbulences of mercury in the drop, transferred to the adjacent solution, and disturbing the regular hydrodynamic regime defining the current. As the interfacial tension electrode/solution, γ , depends on the electrode potential, the spontaneous drop-time of DME, t_1 , becomes shorter with increasing negative potential. To get rid of this inconsistency an automatic device is used, which knocks the drop off the capillary at a constant time. – For DME in → *polarography* best suited is the → *Smoler's* capillary, which eliminates transfer of electrolytic products among subsequent drops, in measurements of interfacial tension the “spindle” capillary [vi] is recommended, which by its inner conical shape minimizes penetration of the solution by capillary forces to the interior of the capillary, and thereby issues mercury drops with drop-time of highest reproducibility. – By stopping the growth of mercury drops from DME the → *static mercury drop electrode (SMDE)* or → *hanging mercury drop electrode (HMDE)* is produced.

Refs.: [i] Varley CF (1871) *Philos Trans* 101:129; [ii] Palmer W (1907) *Z phys Chem* 59:129; [iii] Labin R, Oref I (1977) *J Appl Phys* 48:406; [iv] Heyrovský J (1923) *Philos Mag* 45:303; [v] Heyrovský J, Shikata M (1925) *Recl Trav Chim Pay-B* 44:496; [vi] Novotný L, Heyrovský M (1987) *Trends Anal Chem* 6:176

MHcy

Dry cell — Popular name of batteries made by the addition of starch, flour (Paul Schmidt, 1899), or other gelling agents to the liquid electrolyte solution which then shows no typical properties of a water-like liquid anymore, in particular it is nonspillable. One of the first representatives of this class of primary cells was designed by → *Leclanché*.

Ref.: [i] Linden D, Reddy TB (eds) (2002) *Handbook of batteries*. McGraw-Hill, New York

RH

Dry-charged battery — Batteries that are shipped and stored in the charged state, but dry and free of electrolyte. Under such conditions the batteries exhibit very long shelf life, and can be rapidly activated by introducing the electrolyte upon demand. Silver-oxide based bat-

teries, both primary and secondary, can be stored dry-charged almost indefinitely. Dry-charged → *lead-acid batteries* are produced either by emptying the electrolyte after manufacturing the full battery and charging, or by separately charging the plates before assembly in the battery. Dry-charged lead-acid batteries are made for the purpose of extending shelf life, especially during shipping and when exposure to high temperatures is expected.

Refs.: [i] Salkind AJ, Kelley JJ, Cannone AG (1994) *Lead-acid batteries*. In: Linden D (1994) *Handbook of batteries*, 2nd edn. McGraw-Hill, New York, p 24.32–24.33; [ii] Crompton TR (2000) *Battery reference book*, 3rd edn. Newnes, Oxford, p 5/4, 20/5, Glossary p 4

YG

Dry pile → *Ritter* was the first who constructed piles of galvanic cells with “dry” separators, e.g., of leather. The function of these piles is based on the small amounts of humidity in these separators.

Ref.: [i] Ostwald W (1896) *Elektrochemie. Ihre Geschichte und Lehre*. Veit, Leipzig. Engl transl: Ostwald W (1980) *Electrochemistry. History and Theory*. 2 vols. Amerind Publ, New Delhi

FS

du Bois-Reymond → *Bois-Reymond*

du Bois-Reymond–Poggendorff compensation method → *Poggendorff compensation circuit*, → *Bois-Reymond*, → *Poggendorff*

Dufour effect → *Soret effect*

Dupré equation — The equation gives the work of adhesion W_{A-B} between two immiscible liquids A and B: $W_{A-B} = \gamma_{A-V} + \gamma_{B-V} - \gamma_{A-B}$, where γ denotes the interfacial tensions between the different phases (A–V: liquid A–vapor A, B–V: liquid B–vapor B, A–B: liquid A–liquid B).

Ref.: [i] Hunter RJ (2004) *Foundations of colloid science*, 2nd edn. Oxford University Press, Oxford, p 102

FS

Dye-sensitized solar cell — Dye cells are regenerative dye-sensitized photoelectrochemical cells. Its working principle for energy conversion is based upon photon absorption by a sensitizer with subsequent electron transfer from a photoexcited state of the sensitizer into the → *conduction band* of a → *semiconductor*, and from the semiconductor to external circuitry. A charge mediator, a suitable → *redox couple* is added to the cell → *electrolyte* for re-reducing the oxidized dye. The mediator is

renewed in the → *counter electrode*, making this photoelectrochemical cell regenerative.

Refs.: [i] Hagfeldt A, Grätzel M (1995) *Chem Rev* 95:49; [ii] Longo C, Nogueira AF, Cachet H, De Paoli MA (2002) *Solid-state and flexible solar cells based on dye-sensitized TiO₂: study by electrochemical impedance spectroscopy*. In: Kafafi ZH (ed) *Organic photovoltaics II – Proceedings of SPIE*, vol. 4465. Washington, pp 21–30

Dynamic hydrogen electrode (DHE) — is a → *hydrogen electrode* used as → *reference electrode* and relying on the passage of a small current between two inert electrodes. At least one of these is a cathodically polarized → *platinized platinum electrode* (→ *electrode materials*) on which H₂ is continually being evolved while O₂ is formed on the second electrode. The two electrodes must be positioned in such a way that the O₂ does not affect the H₂ electrode potential, and the gases must be properly vented. The magnitude of the DHE polarization corresponding to the applied current must be corrected. This correction is best accomplished by calibrating DHE against a conventional H₂ electrode. Typical corrections are between 15 and 40 mV. For accuracy within a few mV, a constant current source must be employed. A battery with a large series resistor is used to simulate a constant current source because both DHE and its → *counter electrode* must be kept electrically floating. As the battery voltage decreases with time, the DHE potential slowly drifts, being typically less than 5 mV in 2 days. The DHE is advantageous with respect to other reference electrodes because (a) no impurities, such as Cl[−] or Hg²⁺, are produced, (b) the potential against the H₂ electrode is measured under the same conditions as those of the → *working electrode* with correction for a polarization term taken into account, (c) it has no temperature limitation, (d) it is applicable at any pH with a diaphragm of low resistance as long as no incompatible product is present in the electrolyte, (e) it is more suitable than other reference electrodes for fast transient measurements where the resistance between the reference and working electrode has to be kept small. The advantage of the DHE compared to a conventional H₂ electrode is that a H₂ gas sup-

ply is unnecessary, and contamination of the test solution by H₂ is minimized. The DHE cannot compete with classical reference electrodes if extreme accuracy is required.

Ref.: [i] Will FG, (1986) *J Electrochem Soc* 133:454

WK

IH **Dynamic random access memory** → *DRAM*

Dynamic techniques (in electrochemistry) — These are techniques where the excitation functions are **time-dependent** potentials, currents, or charges: (a) controlled potential techniques are voltammetric techniques (→ *voltammetry*, → *cyclic voltammetry*, → *cyclic staircase voltammetry*, → *differential pulse voltammetry*, → *polarography*, → *stripping voltammetry*, etc.) (b) controlled current techniques are → *chronopotentiometry* techniques, (c) controlled charge techniques, i.e., → *coulostatic techniques*, are much more rarely applied. See also → *Relaxation techniques*. The time dependence of the excitation signals implies that the → *charge-transfer kinetics* and the rate of → *mass transport* of educts to and products from the electrode play a significant role. This is the basis to access kinetic and transport parameters, like the standard rate constant (see → *reaction rate*) of → *electron transfer* and → *diffusion coefficients* with these techniques. (The counterpart of dynamic techniques are the static techniques, most importantly → *potentiometry*, and potentiostatic → *amperometry* under constant mass transport conditions (e.g., in → *flow-through cells*, in stirred solutions, or with a → *rotating disc electrode*). Under these conditions no time dependence of the measured potential or current will occur, or if it happens to occur, the time dependence results from the → *time constant* of the electrode or flow-through cell.)

Refs.: [i] Kissinger PT, Heineman WR (1996) *Laboratory techniques in electroanalytical chemistry*, 2nd edn. Marcel Dekker, New York; [ii] Bard AJ, Faulkner LR (2001) *Electrochemical methods*, 2nd edn. Wiley, New York; [iii] Bard AJ, Stratmann M, Unwin PR (eds) (2003) *Instrumentation and electroanalytical chemistry. Encyclopedia of Electrochemistry*, vol. 3. Wiley-VCH, Weinheim

FS

E

E–pH diagram → *Pourbaix diagram*

Eadie–Hofstee plot → *Michaelis–Menten kinetics*

Eastman's entropy → *heat of transport*

Earth cell — This was a → *battery* consisting of a copper and zinc electrode immersed in soil. It was used to produce electricity for telegraphing. See also → *Daniell cell*, → *zinc*, → Zn^{2+}/Zn electrodes, → $Zn^{2+}/Zn(Hg)$ electrodes, → *zinc–air batteries (cell)*, and → *Leclanché cell*.

Ref.: [i] Hauck WP (1883) *Die Galvanischen Batterien, Accumulatoren und Thermosäulen*, 2nd edn. Hartleben's Verlag, Wien

FS

Earthing — is the fastening of electrical equipment to earth to make the earth a part of an electrical circuit (→ *grounding*), i.e., the mounting of a low-resistance electrically conducting connection between electrical apparatus, on one side, and the earth, on the other. The specific electrical resistivity of (wet) earth is about 100 Ω m [i]. Earthing is primarily done for the protection against lightning strikes and electrostatic discharges (ESD), via influence or induction, but also to eliminate electric fields within a volume and to avoid noise in communication engineering devices. In the latter-mentioned broader meaning, this includes all measures to prevent the pick-up or transmission of stray electrical signals. See for the latter → *shielding*.

Ref.: [i] Westphal WH (ed) (1952) *Physikalisches Wörterbuch*. Springer, Berlin, p 367

MHer

Ebner cell — This was a → *battery* consisting of a platinized lead plate and a bottom electrode of a mercury pool with pieces of zinc. The electrolyte is dilute sulfuric acid. See also → *Tyer battery*, → *Daniell cell*, → *zinc*, → Zn^{2+}/Zn electrodes, → $Zn^{2+}/Zn(Hg)$ electrodes, → *zinc–air batteries (cell)*, and → *Leclanché cell*.

Ref.: [i] Hauck WP (1883) *Die Galvanischen Batterien, Accumulatoren und Thermosäulen*, 2nd edn. Hartleben's Verlag, Wien

FS

E_{irrev} diagnostics in cyclic voltammetry — For electrochemical systems with kinetic constraints in the heterogeneous electron transfer reaction (→ *irreversibility*)

the following diagnostic criteria can be used in → *cyclic voltammetry* [i–iii]:

- for reduction processes: $I_{p,Red}/I_{p,Ox} < 1$;
- the half-wave peak potential ($\Delta E_{p/2}$) shifts for 30 mV/ αn in negative direction (for reduction processes), per decade increase of the scan rate (α is the → *transfer coefficient*);
- the peak currents are proportional to the square-root of the scan rate $\nu^{0.5}$ (by redox reactions controlled by diffusion);
- the potential separation between the cathodic and anodic peak $\Delta E_p = |E_{p,c} - E_{p,a}| > 57/n$ mV at 25 °C (see Fig. 1 below) and it increases by increasing the scan rate.

E

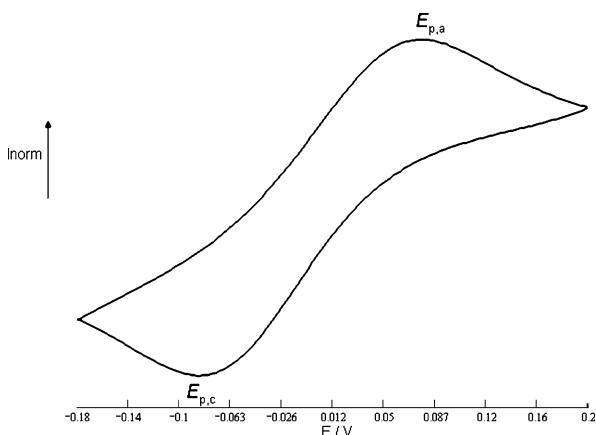

E_{irrev} diagnostics in cyclic voltammetry — **Figure 1.** Simulated cyclic voltammogram for an E_{irrev} reaction

Refs.: [i] Nicholson RS, Shain I (1964) *Anal Chem* 36:706; [ii] Marken F, Neudeck A, Bond AM (2001) *Cyclic voltammetry*. In: Scholz F (ed) *Electroanalytical methods*. Springer, Berlin, pp 50–97; [iii] Bard AJ, Faulkner LR (2001) *Electrochemical methods*. 2nd edn. Wiley, New York, pp 226–260

RG

E_{rev} diagnostics in cyclic voltammetry — For an electrochemically reversible reaction (controlled by diffusion) of the type $O + ne^- \rightleftharpoons R$ (see → *reversibility*), the diagnostic criteria are as follows in → *cyclic voltammetry* [i, ii]:

- I_p (for both, reduction and oxidation) is a linear function of the square-root of the scan rate $\nu^{0.5}$;
- the ratio $I_{p,Red}/I_{p,Ox} = 1$ for wide range of scan rates;

- the half-wave peak potential ($\Delta E_{p/2}$) does not change by altering the scan rate;
- the potential separation between the cathodic and anodic peak $\Delta E_p = |E_{p,c} - E_{p,a}|$ is $57/n$ mV at 25 °C (see Fig. 2 below) [i–iii];

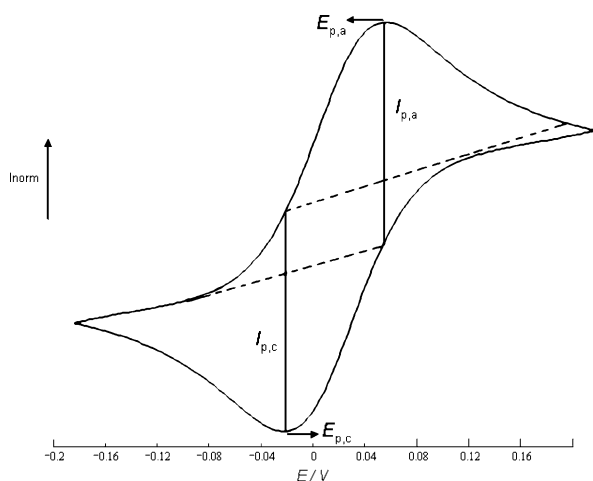

E_{rev} diagnostics in cyclic voltammetry — Figure 2. Simulated cyclic voltammogram for E_{rev} reaction

Refs.: [i] Nicholson RS, Shain I (1964) *Anal Chem* 36:706; [ii] Marken F, Neudeck A, Bond AM (2001) *Cyclic voltammetry*. In: Scholz F (ed) *Electroanalytical methods*. Springer, Berlin, pp 50–97; [iii] Bard AJ, Faulkner LR (2001) *Electrochemical methods*. 2nd edn. Wiley, New York, pp 226–260

RG

Ebonex electrodes — When TiO_2 is placed into an atmosphere of hydrogen at a temperature higher than 1000 °C partial reduction and formation of TiO_{2-x} phases occurs. Of particular interest is Ti_4O_7 , a black ceramic material of high electrical conductivity and chemical inertness. This material, Ebonex, has been formed into ceramic electrodes for applications as → *dimensionally stable anode* [ii] or → *cathode* [iii].

Refs.: [i] Hayfield PCS (2002) *Development of a new material: Monolithic Ti_4O_7 ebonex ceramic*. The Royal Society of Chemistry, London; [ii] Graves JE, Pletcher D, Clarke RL, Walsh FC (1992) *J Appl Electrochem* 22:200; [iii] Chen G, Betterton EA, Arnold RG, Ela WP (2003) *J Appl Electrochem* 33:161

FM

EC process — This is a case where the product (R) of an electrochemical reaction (E) reacts (e.g., with the solvent) to produce a species that is not electroactive at po-

tentials where the redox process of the electroactive couple occurs [i–iii]:



The oxidation of ascorbic acid, followed by hydration of the product is one representative example for this type of reactions [i] and subsequent chemical reactions in electrochemistry.

Refs.: [i] Nicholson RS, Shain I (1964) *Anal Chem* 36:706; [ii] Marken F, Neudeck A, Bond AM (2001) *Cyclic voltammetry*. In: Scholz F (ed) *Electroanalytical methods*. Springer, Berlin, pp 50–97; [iii] Bard AJ, Faulkner L (2001) *Electrochemical methods*. 2nd edn. Wiley, New York, pp 471–533

RG

EC' process — This is a special type of follow-up reaction of the product (R) of the electrochemical step with some nonelectroactive species (Z) in solution, to regenerate initial electroactive substrate, O. i.e.:

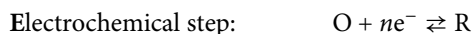

If the concentration of Z is much larger than that of O, the chemical reaction is pseudofirst order. The reduction of Ti(IV) in the presence of oxalate and hydroxylamine follows this pattern of catalytic chemical reactions in electrochemistry (→ *catalytic currents*). The typical features of the EC' reactions (under conditions of cyclic voltammetry) are reflected in increasing cathodic

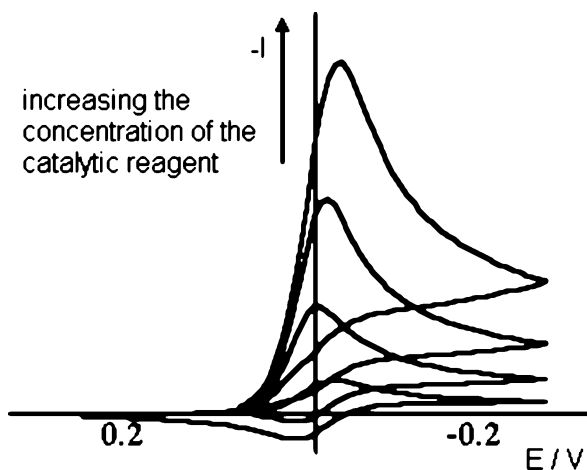

EC' process — Figure. Influence of the concentration of the catalytic reagent Z to the current components of the cyclic voltammograms by an EC' reaction

peak and decreasing anodic peak with increasing concentration of Z (see Figure on the previous page) [i–iv].
 Refs.: [i] Nicholson RS, Shain I (1964) *Anal Chem* 36:706; [ii] Marken F, Neudeck A, Bond AM (2001) *Cyclic voltammetry*. In: Scholz F (ed) *Electroanalytical methods*. Springer, Berlin, pp 50–97; [iii] Zeng J, Osteryoung RA (1986) *Anal Chem* 58:2766; [iv] Bard AJ, Faulkner L (2001) *Electrochemical methods*. 2nd edn. Wiley, New York, pp 471–533

RG

ECE process — Reactions where two charge-transfer reactions are coupled by a chemical reaction. In most cases, the product B of a subsequent chemical reaction ($\rightarrow EC$ process) is itself an electroactive species. Schematically, the reaction can be written as follows:

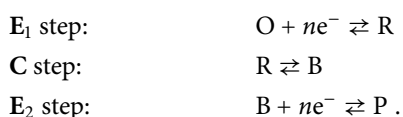

Such reaction pathways are common for many systems, e.g., isomerizations, couplings, and homogeneous disproportionation, studied mainly in nonaqueous media [i–iii]. The reduction of *p*-nitrosophenol is a typical example [ii]:

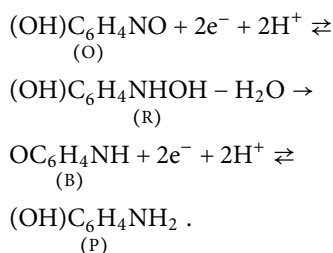

Refs.: [i] Adams RN (1971) *Electrochemistry at solid electrodes*. Marcel Dekker, New York; [ii] Nicholson RS, Shain I (1965) *Anal Chem* 37:190; [iii] Bard AJ, Faulkner LR (2001) *Electrochemical methods*. 2nd edn. Wiley, New York, pp 471–533

RG

$E_{rev}C_{irrev}E_{rev}$ diagnostics in cyclic voltammetry — If two electron transfer steps are coupled by an irreversible chemical reaction, the $E_{rev}C_{irrev}E_{rev}$ mechanisms can be schematically given as follow:

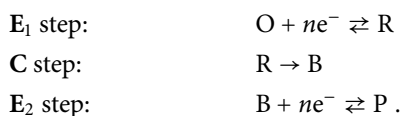

At least two cases should be considered [i–iii]:

- a) when the standard redox potential of the second electron transfer step is more negative than the

standard redox potential of the first electron step (in reductions), then the reoxidation wave corresponding to the oxidation of R to O diminishes by decreasing the scan rate, while the voltammetric signal at more negative potentials attains features of an E_{rev} reaction (see Fig. 1 below).

E

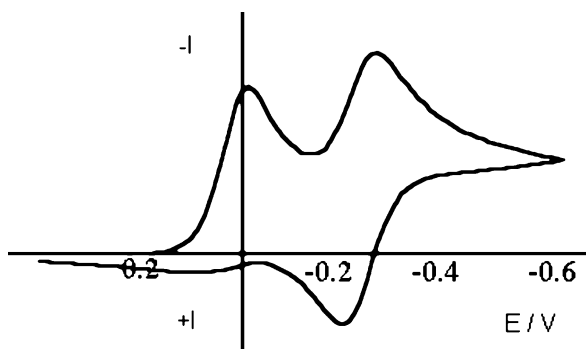

$E_{rev}C_{irrev}E_{rev}$ diagnostics in cyclic voltammetry — Figure. Simulated cyclic voltammograms for an $E_{rev}C_{irrev}E_{rev}$ reaction, where the second E-step occurs at potentials more negative than the first E-step

- when the standard redox potential of the second electron transfer step is more positive than the standard redox potential of the first electron step (in reductions), then in the first scan, only one peak is observed, while after the second scan, another peak at more positive potentials appears. The backward component of the first voltammetric system, i.e., the anodic peak current, diminishes by decreasing the scan rate, while the voltammetric signal at more negative potentials gets features of an E_{rev} reaction.

The diagnostic criteria for the first voltammetric signal are identical to those for an $E_{rev}C_{irrev}$ reaction $\rightarrow E_{rev}C_{irrev}$ diagnostics, while for the second voltammetric criteria the diagnostic criteria are those given for $C_{irrev}E_{rev} \rightarrow$ see $C_{rev}E_{rev}$ diagnostics.

Refs.: [i] Marken F, Neudeck A, Bond AM (2001) *Cyclic voltammetry*. In: Scholz F (ed) *Electroanalytical methods*. Springer, Berlin, pp 50–97; [ii] Heinze J (1984) *Angew Chem* 23:831; [iii] Bard AJ, Faulkner LR (2001) *Electrochemical methods*. 2nd edn. Wiley, New York, pp 471–533

RG

$E_{rev}C_{dim,irrev}$ diagnostics in cyclic voltammetry — Irreversible dimerization is a typical reaction of electrochemically generated radical ions. It is known for a variety of chemical compounds, particularly organic π -systems [i, ii]. The diagnostic criteria for the simplest

reaction scheme of $E_{\text{rev}}C_{\text{dim,irrev}}$ are:

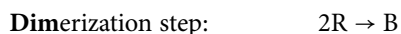

E

- the peak potential is dependent on the concentration of the reactant
- $I_{p,c}/I_{p,a} > 1$ (for reduction processes)
- the peak potentials shift for $20/n$ mV in positive direction per decade increase in the scan rate.

Refs.: [i] Heinze J (1984) *Angew Chem* 23:831; [ii] Bard AJ, Faulkner LR (2001) *Electrochemical methods*. 2nd edn. Wiley, New York, pp 471–533

RG

$E_{\text{rev}}C_{\text{irrev}}$ diagnostics in cyclic voltammetry — Assuming that the product (R) of an electrochemically reversible electron transfer reaction (E step) is involved in additional irreversible chemical reaction (C step), according to the scheme;



the following diagnostic criteria are valid for cyclic voltammetry [i–iii]:

- the ratio $I_{p,\text{Red}}/I_{p,\text{Ox}}$ (for reduction processes) > 1 , and it decreases by increasing the scan rate;
- for fast scan rates, the cyclic voltammograms attain the shape typical for unperturbed simple electron transfer reactions $\rightarrow E_{\text{rev}}$;

- the backward (re-oxidation) component of the current at more positive potentials (by reduction processes) diminishes by decreasing the scan rate (see Figure 1 below);

- the peak currents are proportional to the $v^{0.5}$;
- in the kinetically controlled region, the half-wave peak potential $\Delta E_{p/2}$ shifts for $30/n$ mV in positive direction per decade increase in the scan rate (for reduction processes).

Refs.: [i] Nicholson RS, Shain I (1964) *Anal Chem* 36:706; [ii] Marken F, Neudeck A, Bond AM (2001) *Cyclic voltammetry*. In: Scholz F (ed) *Electroanalytical methods*. Springer, Berlin, pp 50–97; [iii] Bard AJ, Faulkner LR (2001) *Electrochemical methods*. 2nd edn. Wiley, New York, pp 471–533

RG

$E_{\text{rev}}C_{\text{rev}}$ diagnostics in cyclic voltammetry — If the chemical step, following the electrochemically reversible electron transfer, is also reversible (see scheme below),



then, the diagnostic features of the cyclic voltammograms for such $E_{\text{rev}}C_{\text{rev}}$ systems are [i–iii]:

- the ratio $I_{p,\text{Red}}/I_{p,\text{Ox}}$ (for reduction processes) > 1 , and it decreases by decreasing the scan rate;

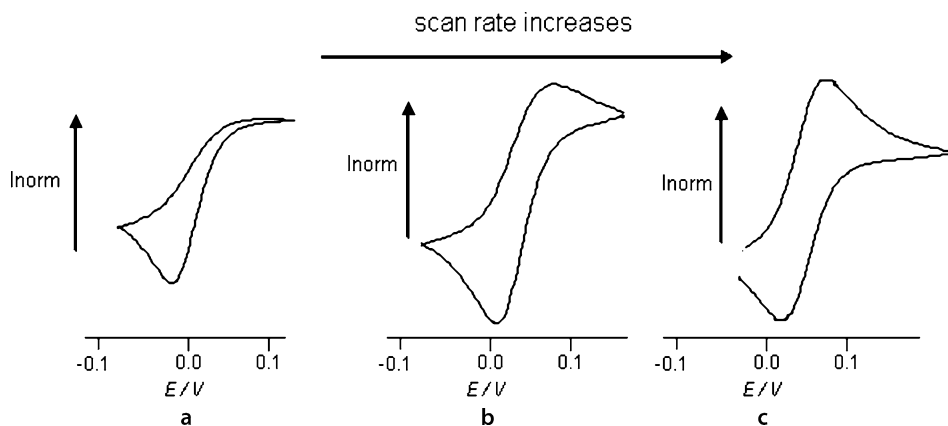

$E_{\text{rev}}C_{\text{irrev}}$ diagnostics in cyclic voltammetry — Figure. The effect of the scan rate to the current components of the simulated cyclic voltammograms of an $E_{\text{rev}}C_{\text{irrev}}$ reaction

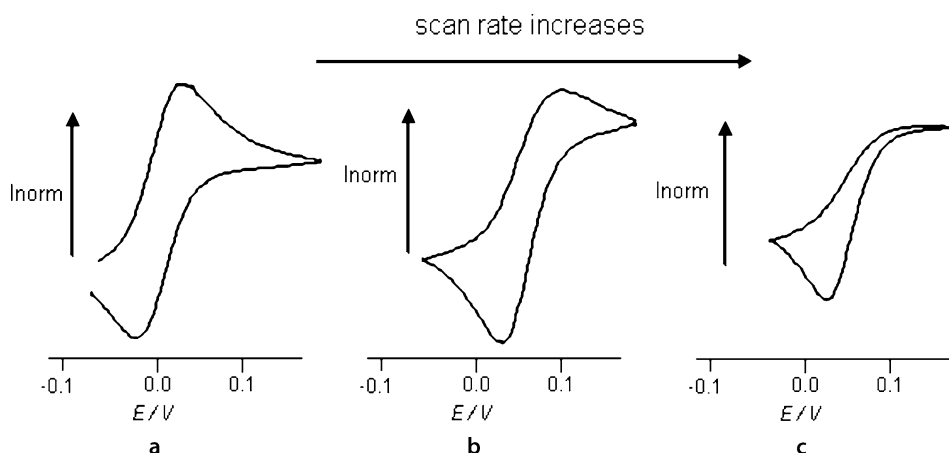

$E_{rev}C_{rev}$ diagnostics in cyclic voltammetry — **Figure.** The effect of the scan rate to the current components of the simulated cyclic voltammograms of an $E_{rev}C_{rev}$ reaction

- for slow scan rates, the cyclic voltammograms attain the shape typical for unperturbed simple electron transfer reaction (see $\rightarrow E_{rev}$).
- the reoxidation signal (R to O) diminishes by increasing the scan rate;
- the peak currents are proportional to the $v^{0.5}$;
- in the kinetically controlled region, the half-wave peak potential $\Delta E_{p/2}$ shifts by $30/n$ mV in positive direction per decade increase in the scan rate (for reduction processes).

Refs.: [i] Nicholson RS, Shain I (1964) *Anal Chem* 36:706; [ii] Marken F, Neudeck A, Bond AM (2001) *Cyclic voltammetry*. In: Scholz F (ed) *Electroanalytical methods*. Springer, Berlin, pp 50–97; [iii] Bard AJ, Faulkner LR (2001) *Electrochemical methods*. 2nd edn. Wiley, New York, pp 471–533

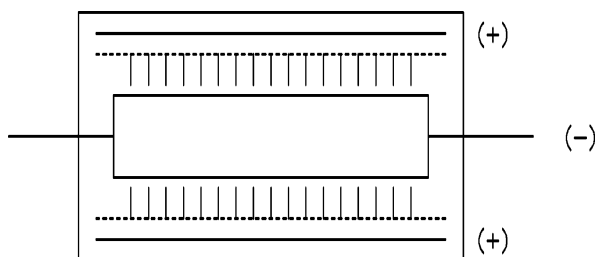

ECO cell — **Figure.** Cross section of an ECO cell

Ref.: [i] Zirngiebl E (1993) *Einführung in die Angewandte Elektrochemie*. Salle & Sauerländer, Frankfurt

RH

Eco-Tec Recowin cell — Electrochemical cell for metal recovery with air-sparging for improved mass transport.

Ref.: [i] Pletcher D, Walsh FC (1993) *Industrial electrochemistry*. Blackie Academic & Professional, London

RH

ECROW \rightarrow electron-conductor separating oil water system

Edge effect — Enhanced diffusion to the edges of an in-laid electrode. See \rightarrow electrode geometry, and \rightarrow diffusion, subentry \rightarrow edge diffusion.

CGZ

ECO cell — Electrochemical cell which is applied in wastewater treatment. A rotating cylinder employed as cathode and fixed anodes at the periphery are separated by a \rightarrow diaphragm. Small disks reaching from the separator up to close to the rotating cathode split the \rightarrow catholyte section into small ring-shaped compartments. Movement of the solution from one compartment to the next is possible only through the small gap.

This results in high turbulence and good faradaic yield, up to 65% have been reported, a typical run reduced the copper content of a wastewater by almost two orders of magnitude.

Edison, Thomas Alva

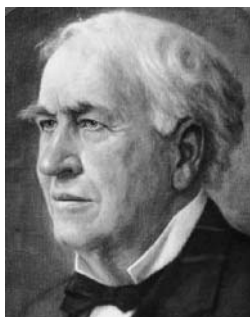

(Feb. 11, 1847, Milan, Ohio, USA – Oct. 18, 1931, West Orange, New Jersey, USA) Without a formal education Edison became one of the greatest inventors holding more than 2000 patents in his name, among others those related to electrical telegraphy, electric vote recorder, phonograph (gramophone), incandescent electric lamp, motion picture camera, electric trains. Some of the inventions credited to him were improvements of earlier inventions and also the merit of his co-workers, e.g., William Joseph Hammer, Graham Bell, Nikola Tesla, however, many devices developed in his laboratories greatly influenced life in the 20th century. Edison's major innovation was the first industrial research lab which was built in Menlo Park, New Jersey.

The rechargeable alkaline nickel–iron → *Edison cell* (1901) is still used as a power source.

Refs.: [i] Jonnes J (2003) *Empires of light: Edison, Tesla, Westinghouse, and the race to electrify the world*. Random House, New York; [ii] Larousse Dictionnaire (1991) *Librairie Larousse*. Paris; [iii] Dunsch L (1985) *Geschichte der Elektrochemie*. VEB Deutscher Verlag für Grundstoffindustrie, Leipzig, pp 92; [iv] Israel PB (2002) *Endeavour* 26:48

GI

Edison cell — A nickel–iron (Ni–Fe) secondary (rechargeable) cell independently developed by → *Edison* in USA and W. Jünger in Sweden in 1900. The cell (→ *battery*) is based on the use of nickel oxyhydroxide (NiOOH) at the positive electrode and metallic iron for the negative electrode, and a potassium hydroxide (KOH) solution containing lithium hydroxide (LiOH) is the electrolyte. The Ni–Fe cell is represented as $(-)\text{Fe}/\text{KOH}/\text{NiOOH}(+)$. The charge–discharge reactions for the Edison (Ni–Fe) cell are as follows:

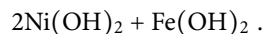
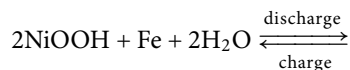
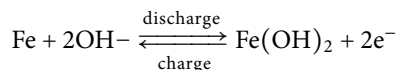
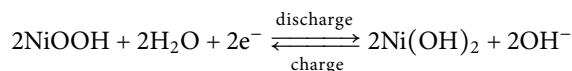

The nominal open-circuit voltage and mean discharge voltage of these cells are 1.37 V at 25 °C and 1.2 V, respectively. During the discharge of a Ni–Fe cell with negative-limited configuration there is a second step, at a potential lower than the first step as, $\text{NiOOH} + \text{Fe}(\text{OH})_2 \xrightleftharpoons[\text{charge}]{\text{discharge}} \text{Ni}(\text{OH})_2 + \text{FeOOH}$, with a circuit

voltage $E_{\text{cell}} = 1.05$ V. The cell reactions are highly reversible in the alkaline electrolyte solutions, particularly if the charge is limited to the first step.

The use of Ni–Fe batteries was important from its introduction in 1908 until the 1970s, when they lost their market share to the industrial → *lead–acid accumulators*. They were used in materials-handling trucks, mining and underground vehicles, railroad and rapid-transit cars, and in stationary applications. The main advantages of the Ni–Fe battery are extremely rugged construction, long life (>2000 cycles) and durability (15–20 years). Its limitations: low specific energy (~50 Wh kg⁻¹), poor charge retention, and poor low-temperature performance and its high cost of manufacture compared with the lead–acid battery led to a decline in importance.

Refs.: [i] Shukla AK, Ravikummar MK, Balasubramanian TS (1994) *J Power Sources* 51:29; [ii] Chakkaravarthy C, Periasamy P, Jegannathan S, Vasu KI (1991) *J Power Sources* 35:21; [iii] Hariprakash B, Martha SK, Hegde MS, Shukla AK (2005) *J Appl Electrochem* 35:27; [iv] Jackovitz JF, Bayles GA (2002) *Iron electrode batteries*. In: Linden D, Reddy TB (eds) *Handbook of batteries*, 3rd edn. McGraw-Hill, New York; [v] Crompton TR (2000) *Battery reference book*, 3rd edn. Newness, Oxford

DA, GS

EDL capacitor → *supercapacitor*

Effective molarity (or effective concentration) — The ratio of the first-order rate constant of an intramolecular reaction involving two functional groups within the same → *molecular entity* to the second-order rate constant of an analogous intermolecular elementary reaction. This ratio has the dimension of concentration. The term can also apply to an equilibrium constant.

Ref.: [i] Muller P (1994) *Pure Appl Chem* 66:1077

WK

Eigen complex — In 1954, M. Eigen (Nobel Prize in Chemistry 1967) proposed from thermodynamic mea-

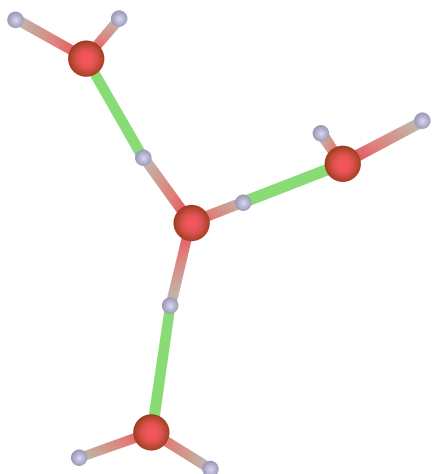

Eigen complex — Figure

surements that the excess hydronium ion builds the center of an H_9O_4^+ complex (see Figure). In this primary \rightarrow solvation structure, which is called Eigen complex, the \rightarrow proton is coordinated by – and strongly hydrogen-bonded to – three neighboring water molecules. Inside the Eigen complex, the protons are assumed to be practically freely movable.

The most plausible structure competitive to the Eigen complex is the \rightarrow Zundel complex, where the proton is shared equally between two water molecules. According to computer simulations (ab-initio molecular dynamics) [iii], both, Eigen and Zundel complexes are involved in the migration process, but neither of them as a preferred isodynamic state. They rather represent idealized borderline structures, i.e., can be transferred one into another with practically no energy threshold. Further, only quantum-mechanical zero-point oscillations of the excess proton between two water molecules make the Zundel complex energetically equivalent to the Eigen complex: In a pure classical energy model, Eigen complex is at a distinct lower energy state, with Zundel complex being a short intermediate. However, quantum-mechanical (tunnel) effects play quasi no role in the whole proton migration process (see \rightarrow prototropic charge transport); rate determining are the (much slower) fluctuations of the water molecules in the outer solvation core – which are of classical thermic nature.

Refs.: [i] Wicke E, Eigen M, Ackermann Th (1954) *Z phys Chem* 1:340; [ii] Eigen M (1964) *Angew Chem Int Ed Engl* 3:1; [iii] Marx D, Tuckerman ME, Hutter J, Parrinello M (1999) *Nature* 397:601

Eighteen-electron rule — An electron-counting rule to which an overwhelming majority of stable diamagnetic transition metal complexes adhere. The number of non-bonded electrons at the metal plus the number of electrons in the metal–ligand bonds should be 18. The 18-electron rule in transition metal chemistry is a full analogue of the “Lewis octet rule”.

Ref.: [i] Muller P (1994) *Pure Appl Chem* 66:1077; [ii] Jensen WB (2005) *J Chem Educ* 82:28

WK

Einstein, Albert



(© The Nobel Foundation)

(Mar. 14, 1879, Ulm, Germany – Apr. 18, 1955, Princeton, USA) Einstein gained his teacher’s diploma in physics and mathematics at the Swiss Federal Polytechnic School in 1901. He obtained his doctoral degree at the University of Zurich in 1905 for a thesis “On a new determination of molecular dimensions”. In 1908 he was appointed Privatdozent at the University of Bern after submitting his habilitation thesis “Consequences for the constitution of radiation following from the energy distribution law of black bodies”. In 1909 he became Professor Extraordinary at the University of Zurich, in 1911 Professor of Theoretical Physics at the Karl-Ferdinand University in Prague. He moved from Prague to Zurich in 1912 to take up a chair at the Eidgenössische Technische Hochschule. In 1914 he was appointed Director of the Kaiser Wilhelm Physical Institute and Professor at the University of Berlin. Einstein received the Nobel Prize in Physics in 1921 “for his services to Theoretical Physics, and especially for his discovery of the law of the photoelectric effect”. It was announced on November 9, 1922. Einstein did not attend the ceremony in 1922, and he delivered his Nobel lecture on July 11, 1923. Einstein left Germany in 1933, and emigrated to the United States of America to take the position of Professor of Theoretical Physics at the Institute for Advanced Study at Princeton. The year 1905 is called “annus mirabilis” of Einstein. In his papers published during this year he provided an

MH

explanation and theoretical background for the photoelectric effect and the quantization of energy [i], for Brownian motion [ii, iii], and the special theory of relativity [iv, v]. He wrote further papers on the elementary theory of Brownian motion [vi–vii] which appeared in ‘Zeitschrift für Elektrochemie’ (!) explaining his approach to chemists. In 1916 he published his paradigmatic work on the general theory of relativity. When British eclipse expeditions in 1919 confirmed his predictions, Einstein became the most famous scientist.

In electrochemistry several equations are used that bear Einstein’s name [viii–ix]. The relationship between electric mobility and diffusion coefficient is called Einstein relation. The relation between conductivity and diffusion coefficient is called → *Nernst–Einstein equation*. The expression concerns the relation between the diffusion coefficient and the viscosity and is known as the → *Stokes–Einstein equation*. The expression that shows the proportionality of the mean square distance of the random movements of a species to the diffusion coefficient and the duration of time is called → *Einstein–Smoluchowski equation*. A relationship between the relative viscosity of suspension and the volume fraction occupied by the suspended particles – which was derived by Einstein – is also called Einstein equation [ix].

It should be mentioned that in physics other equations are called Einstein equations such as the relationship between mass and energy, and the field equation of Einstein.

Refs.: [i] Einstein A (1905) *Ann Phys* 17:132; [ii] Einstein A (1905) *Ann Phys* 17:549; [iii] Einstein A (1906) *Ann Phys* 19:371; [iv] Einstein A (1905) *Ann Phys* 17:891; [v] Einstein A (1905) *Ann Phys* 18:639; [vi] Einstein A (1907) *Z Electrochem* 13:41; [vii] Einstein A (1908) *Z Elektrochem* 14:235; [viii] Brett CMA, Oliveira Brett AM (1993) *Electrochemistry*. Oxford University Press, Oxford, pp 28–29; [ix] Erdey-Grúz T (1974) *Transport phenomena in aqueous solutions*. Adam Hilger, London

GI

Einstein equation → *Einstein*

Einstein relation → *Einstein*

Einstein–Smoluchowski equation — Relationship between diffusion coefficient D , average width of a jump λ of a microscopic species (atom, ion, molecule) involved in diffusion, and average time τ between two jumps

$$D = \frac{\lambda^2}{2\tau}$$

The time τ can be interpreted as the average time of residence of the species under observation close to another

species. This equation provides the connection between the macroscopic description of diffusion with D and the microscopic picture of moving single species. In addition the ratio λ/τ can be associated with the average velocity v in case of a perfect gas. Thus λ can be associated with the mean free path length in a gas. See also → *Einstein*, → *Smoluchowski*.

Refs.: [i] Einstein A (1905) *Ann Phys* 4:549; (1906) *Ann Phys* 4:371; [ii] Smoluchowski M (1905) *Ann Phys* 4:756; (1916) *Phys Z* 17:557, 585; [iii] Einstein A, Smoluchowski M (1997) *Brownsche Bewegung. Untersuchungen über die Theorie der Brownschen Bewegung. Abhandlung über die Brownsche Bewegung und verwandte Erscheinungen*. Harri Deutsch, Frankfurt; [iv] Atkins PW (1994) *Physical chemistry*. Oxford University Press, Oxford, p 855

RH

Electric double layer (EDL) capacitor → *supercapacitor*

Electrical charge → *charge*

Electrical double layer → *double layer*

Electrical (electric) field — A driving force for the flow of charged particles, e.g., electrons, and transport of ions. Electric field strength, E , is directly related to the → *potential gradient* by the formula $E = -\nabla\Phi$. In conductors, electrons flow only in response to the electric field and the current can be represented by $I = -\nabla\Phi/R$, where R is resistivity. In → *electrochemical cells* the electric field is always substantial within the → *double layer* and is significant in the solution of high resistivity. The transport of ions in a solution in response to an electric field is called → *migration*. Migration is always accompanied by → *diffusion* and sometimes by → *convection*.

Ref.: [i] Newman J, Thomas-Alyea KE (2004) *Electrochemical systems*, 3rd edn. Wiley-Interscience, Hoboken

ZS

Electric field (strength), E — Force acting on a charge divided by the charge. In → *capillary electromigration*, this is taken as the axial component of the field, that is, the difference between the applied electric potential at the sample introduction end of the capillary and that at the detection end, divided by the total length of the capillary, L_{tot} . There is also a radial electric field arising from the → *electrical double layer*, which is involved in → *electroosmosis*. The total length of the capillary is typically larger than the effective length of the capillary, L_{eff} . See → *migration time*.

Ref.: [i] Riekkola ML, Jönsson JÅ, Smith RM (2004) *Pure Appl Chem* 76:443

WK

Electrical organ (of animals) — Electric organ(s), also called electroplax, facilitate some aquatic species to generate electric discharges of different pulse amplitudes and ~ times in order to stun or kill the prey, recognize or contact conspecifics, or for orientation purpose. This organ is supplemented with an array of sensory organs to process the received electric signals of own (reflecting) or extraneous origin in time and spatial manner. At least five or possibly more independent parallel evolutionary strings of *e.o.*'s. are suggested. Besides the commonly known animals with strong electric organ discharges (the ancient Romans applied the electric ray for electroshock therapy treatment of *arthritis* patients), also several species with weak discharges of a few millivolts or less have been investigated mainly since the 1940s. Best known representatives with *e.o.* with strong electrical discharges are the electric eel (*Electrophorus electricus*) and the electric ray (*Torpedinidae*), the latter with a pair of *e.o.*'s, whereas the elephant nose fish (*Gnathonemus petersii*) is known for weak discharges. Generally, species with *e.o.* in seawater utilize a higher sensitivity than those in freshwater. → *Volta* carried out many experiments with electric eels and rays, and it was the very reason that he called his pile (→ *Volta pile*) an artificial electrical organ in his pivotal report [iv].

Looking at the ontogenetic development, the electro-sensing and reception system is basically derived from the lateral line receptors of aquatic animals. The *e.o.* itself evolved from striated musculature. The independent panels, acting as electrical units, are separated by mucoid connective tissue. Each *e.o.* consists of a higher number of such elements (electrocytes) that are spatially arranged to generate the respective discharge. The connective tissue, surrounding the cells, channels the flow of current along the *e.o.* axis into water and back into the other end. The electrocytes maintain a standing emf between the in- and outside by ion pumps. Discharging is initialized from spinal cord nerve cells, under brain control, successively, i.e., at first one face of the electrocytes, then the other. Depending on the arrangement of these faces, both series-connected elements (electric eel: 5000 to 6000 electroplaxes generate up to 500 volts with 1 ampere current) or parallel connected elements (*Torpedo*: high-current, low-voltage discharge) are found.

Refs.: [i] Nelson JS (1994) *Fishes of the world*. Wiley, New York; [ii] Bullock TH, Hopkins CD, Popper AN, Fay RR (eds) (2005) *Electroreception*. Springer, New York; [iii] v Humboldt A, Gay-Lussac (1805) *Neues allg J Chemie* 3:166; [iv] Volta A (1800) *Philos Trans R Soc London* vol. 2, Plate XVII 403; *Philos Mag* 7:289

Electrical potential → *potential*

Electric potential difference of a galvanic cell — Symbol: *E* (recommended) or *U* or ΔV ; SI unit: V.

The electric potential difference of a → *galvanic cell* (cell voltage) is the difference of electric potential between a metallic terminal attached to the right-hand electrode in the → *cell diagram* and identical metallic terminal attached to the left-hand electrode. *E* includes the condition when current flows through the cell. The value of *E* measured when the left-hand electrode is at virtual equilibrium, and hence acting as a → *reference electrode*, may be called the potential of the (right-hand) electrode with respect to the (left-hand) reference electrode.

Refs.: [i] Mills I, Cvitas T, Homann K, Kallay N, Kuchitsu K (eds) (1993) *IUPAC quantities, units and symbols in physical chemistry*. Blackwell Scientific Publications, Oxford, p 58; [ii] Parsons R (1974) *Pure Appl Chem* 37:503; [iii] Bard AJ, Faulkner LR (2001) *Electrochemical methods*. 2nd edn. Wiley, New York, pp 48–52

GI

Electricity — Electricity is the name given to any macroscopic manifestation of electric → *charge*, whether static or dynamic. For historical reasons, bulk quantities of electric charge have traditionally been classified in terms of their motion. Thus, bulk quantities of electric charge are commonly described as either “static electricity” or “dynamic electricity”. Static electricity refers to electric charges at rest, and these can manifest on the surface of either → *insulators* or → *conductors*. By contrast, dynamic electricity refers to electric charges in motion, and those can flow only through conductors or → *semiconductors*. Although static electricity was known to the ancients, the modern study of static electricity is usually traced to the experiments of William Gilbert (1544–1603). Indeed, it was he who coined the word “electric” (in Latin, in the form ‘*Electrica Effluvia*’ [i]). Dynamic electricity was first observed by → *Gray* in 1729 [ii]. Experimentally, a free electric charge has never been observed. Instead, charge is always associated with a → *charge carrier*, which may be a fundamental particle (a quark; or a lepton such as an → *electron*), a composite particle (a baryon such as a → *proton*), a lattice-stabilized entity (such as a → *hole*, or → *polaron*), or a chemical species (such as an → *ion*). On the Standard Model of particle physics, “charge” is one of the four irreducible properties of matter (the other three being “color”, “mass”, and “spin”) and therefore, at the current state of knowledge, it is not capable of further definition.

Refs.: [i] William Gilbert, *De Magnete, Magneticisque Corporibus, et de Magno Magnete Tellure*, (On the Magnet, Magnetic Bodies and the

MHer

Great Magnet, the Earth) pub. Petrus Short (London) 1600; [ii] Stephen Gray, “Two letters from Gray to Mortimer, containing a farther account of his experiments concerning electricity”, *Philosophical Transactions* No 37 (1731–32)

SF

Electroactivity (electroactive or electrochemically active compounds) — The capability of a substance to take part in a faradaic → *electrode reaction*. Electroactive compounds can be in the gaseous, liquid, or solid state or they may be dissolved in (liquid or solid) solutions. Various compounds are also electroactive in the adsorbed state (see → *adsorption*, → *adsorptive accumulation*, → *adsorptive stripping voltammetry*) or as polymer films (see → *polymer-modified electrodes*) on electrodes.

BM

Electroactive polymer films → *conducting polymers*

Electroacoustics — Ultrasound passing through a colloidal dispersion forces the colloidal particles to move back and forth, which leads to a displacement of the double layer around the particles with respect to their centers, and thus induces small electric dipoles. The sum of these dipoles creates a macroscopic AC voltage with the frequency of the sound waves. The latter is called the Colloid Vibration Potential (CVP) [i]. The reverse effect is called Electrokinetic Sonic Amplitude (ESA) effect [ii]. See also → *Debye effect*.

Refs.: [i] Hermans JJ (1938) *Philos Mag* 25:426; [ii] Hunter RJ (2004) *Foundations of colloid science*. Oxford University Press, Oxford, pp 252

FS

Electroanalysis → *electroanalytical chemistry*

Electroanalytical chemistry (or electroanalysis) — Branch of analytical chemistry comprising all electrochemical techniques and methods that are employed to perform analytical determinations [i–iv]. It can be divided into ‘interfacial techniques’, i.e., techniques relying on the specific properties of → *interfaces*, and ‘volume probing’ techniques, e.g., methods relying on the → *conductivity* or → *permittivity* of phases. Electroanalysis comprises ‘static’ (→ *potentiometry*) and ‘dynamic’ techniques (→ *potentiodynamic*, i.e., → *voltammetric*, and → *galvanodynamic* measurements). Further, titrations using electrochemical indication techniques, as well as → *coulometry*, → *electrography* and → *electrogravimetry* belong to electroanalysis. Traditionally → *electrophoresis* is counted as part of separation techniques, although it

is based on electrochemical principles. Electroanalytical techniques can be applied for determination of species in liquids (liquid solutions) [i–iv, vi], in solids (both in solid solutions and solid phase mixtures) [v], and in gases [vi]. Some techniques can also be applied for the analysis of solid phases → *voltammetry of immobilized microparticles* [v].

Refs.: [i] Kissinger PT, Heineman WR (eds) (1996) *Laboratory techniques in analytical chemistry*, 2nd edn. Marcel Dekker, New York; [ii] Bond AM (1980) *Modern polarographic methods in analytical chemistry*. Marcel Dekker, New York; [iii] Wang J (1994) *Analytical electrochemistry*. VCH, New York; [iv] Scholz F (ed) (2005) *Electroanalytical methods*. Springer, Berlin; [v] Scholz F, Schröder U, Gulaboski R (2005) *Electrochemistry of immobilized particles and droplets*. Springer, Berlin; [vi] Göpel W, Hesse J, Zemel JN (eds) (1995–99) *Sensors*, 9 vols. Wiley-VCH, Weinheim

FS

Electrocapillarity Becquerel phenomenon → *Becquerel* [i] discovered the phenomenon that at → *membranes* separating a metal solution containing a metal ion, e.g., of copper nitrate, from a solution of sodium sulfide, a metal salt (e.g., copper sulfide) precipitates on which crystals of the metal grow into the metal solution and sulfide is oxidized on the side of the sodium sulfide solution. The effect is only observed when the precipitated salt is a semiconductor. The effect is due to the formation of a → *galvanic cell* with the semiconductor as the electronic conductor bridging the two solutions and some electrolyte pores in the membrane forming the ionic conductor [ii].

Refs.: [i] Becquerel AC (1867) *Compt rendus* 64:919, 1211; 65:51, 720; (1868) 66:77, 245, 766, 67:1081; (1870) 71:197; (1872) 74:1310; (1873) 76:245; (1874) 78:1081; 79:82, 1281; (1875) 80:585; (1876) 82:354; (1877) 84:145; 85:169; [ii] Freundlich H (1930) *Kapillarchemie*, vol. 1. Akad Verlagsges, Leipzig, pp 383

FS

Electrocapillarity — (a) as a branch of science, this term covers all phenomena related to the thermodynamics of charged → *interfaces*, esp. of metal–solution interfaces. The term is practically synonymous with → *capillarity*, but emphasizes the electric aspects. (b) The term ‘electrocapillarity’ is often used in a restricted sense to mean the study of the equilibrium properties of metal|solution interfaces, such as the → *interfacial tension* of mercury|solution interfaces, the height of a mercury column (in the case of the → *Lippmann capillary electrometer*), or the → *drop time* (in the case of the → *dropping mercury electrode*). More generally, however, the equilibrium properties of many other interfaces fall

within the scope of the theory, such as the \rightarrow *interface between two immiscible electrolyte solutions (ITIES)*.

See also \rightarrow *capillarity*, \rightarrow *adhesion*, \rightarrow *double layer*, \rightarrow *Dupré equation*, \rightarrow *Gibbs–Lippmann equation*, \rightarrow *electrocapillary equation*, \rightarrow *electrokinetic effects*, \rightarrow *Lippmann equation*, \rightarrow *Lippmann capillary electrometer*, \rightarrow *point of zero charge*, \rightarrow *Young equation*, \rightarrow *Wilhelmy plate (slide) method*, \rightarrow *drop weight method*, \rightarrow *ring method*.

Refs.: [i] Bard AJ, Faulkner LR (2001) *Electrochemical methods*. Wiley, New York; [ii] Bard AJ, Stratmann M, Gileadi E, Urbakh M (eds) (2002) *Thermodynamics and electrified interfaces*. Encyclopedia of electrochemistry, vol. 1. Wiley-VCH, Weinheim; [iii] Goodrich FC, Rusanov AI (eds) (1981) *The modern theory of capillarity*. Akademie-Verlag, Berlin; [iv] Hunter RJ (2004) *Foundations of colloid science*. Oxford University Press, Oxford, pp 84

FS

Electrocapillary curve — Graph showing the dependence of \rightarrow *interfacial (or surface) tension* γ on \rightarrow *electrode potential* (see also \rightarrow *potential*) E . The most extensive studies have been carried out with polarized \rightarrow *mercury electrodes*. As exemplified in the Figure, the electrocapillary curve has a nearly parabolic shape, although there are significant variations in the curves as the electrolyte is changed. The first differential of the curve yields the surface charge density of the electrode, Q (see also \rightarrow *Lippmann equation*). At the maximum (**electrocapillary maximum**) of an electrocapillary curve, $Q = 0$. The potential of the maximum is called \rightarrow “*point (or potential) of zero charge (pzc)*” or “*electrocapillary maximum*”. The second differential yields the differential capacity (or \rightarrow *capacitance*) of the electrode, C :

$$-\left(\frac{\partial^2 \gamma}{\partial E^2}\right)_{T,P,\mu} = \left(\frac{\partial Q}{\partial E}\right)_{T,P,\mu} = C.$$

As shown in the Figure, electrocapillary curves are affected by \rightarrow *specific adsorption* of ions (here, anions) at the electrode surface. Additionally, they are influenced by the \rightarrow *space charge region* of the \rightarrow *electrical double layer*. Thus, electrocapillary curves as well as capacitance curves provide useful information on the electrical double-layer structure of electrode surfaces.

Refs.: [i] Grahame DC (1947) *Chem Rev* 41:441; [ii] Delahay P (1965) *Double layer and electrode kinetics*. Wiley, New York; [iii] Mohilner DM (1966) *The electrical double layer: Part I. Elements of double-layer theory*. In: Bard AJ (ed) *Electroanalytical chemistry*, vol. 1. Marcel Dekker, New York

TO

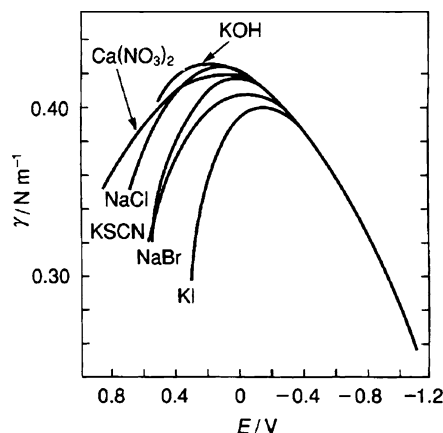

Electrocapillary curve — Figure. Electrocapillary curves of a mercury electrode in aqueous solutions of different electrolytes (modified from [i] with permission)

E

Electrocapillary equation \rightarrow *Gibbs–Lippmann equation*

Electrocapillary maximum \rightarrow *electrocapillary curve*

Electrocatalysis — is the \rightarrow *catalysis* of an \rightarrow *electrode reaction*. The effect of electrocatalysis is an increase of the \rightarrow *standard rate constant* of the electrode reaction, which results in an increase of the \rightarrow *faradaic current*. As the current increase can be masked by other non-electrochemical rate-limiting steps, the most straightforward indication for the electrocatalytic effect is the shift of the electrode reaction to a lower \rightarrow *overpotential* at a given current density. Electrocatalysis, as chemical catalysis, can be either homogeneous or heterogeneous in character. In homogenous electrocatalysis, both the catalyst and the substrate are in the same phase, commonly dissolved in the bulk solution, and the processes at the interface do not influence the chemical steps that involve it. Examples for a homogeneous electrocatalysis are the reduction of hydrogen peroxide, hydroxyl amine, and anionic inorganic oxidant such as chlorate, chlorite, perchlorate, bromate, iodate, nitrate, nitrite, and persulfate, catalyzed by transition metal ions such as Ti(VI), V(V), Cr(III), Mo(VI), W(VI), Fe(III), Co(III), Ru(III), Os(VIII), Y(III), and U(VI) [ii].

In heterogeneous electrocatalysis, the catalyst is immobilized on the electrode surface, or the \rightarrow *electrode* itself plays the role of a catalyst. Catalytic effects of various electrode materials on the hydrogen evolution reaction are typical examples of heterogeneous electrocatalysis [iii]. Further examples are electrode mechanisms involving hydrogen evolution at a mercury electrode catalyzed by adsorbed organic bases, microparti-

cles of platinum metals (Ru, Rh, Ir, Pt), and transition metal complexes [iv], oxygen reduction, and water oxidation. Moreover, numerous examples of heterogeneous electrocatalysis are related to \rightarrow *chemically modified electrodes*, e.g., electrocatalytic oxidation of hydroxylamine at a glassy carbon electrode modified with a cobalt(III) hexacyanoferrate(II) film [v].

Refs.: [i] Bănică FG, Ion A (2000) *Electrocatalysis-based kinetic determination*. In: Meyers RA (ed) *Encyclopedia of analytical chemistry*. Wiley, Chichester, p 11115; [ii] Zaitsev PM, Zhdanov SI, Nikolaeva TD (1982) *Russ Chem Rev* 51:968; [iii] Bockris JO'M, Reddy KN (1970) *Modern electrochemistry*, vol. 2. Plenum Press, New York, p 1141; [iv] Bănică FG, Ion A (2000) *Electrocatalysis-based kinetic determination*. In: Meyers RA (ed) *Encyclopedia of analytical chemistry*. Wiley, Chichester, p 11128; [v] Chen SM (1998) *Electrochim Acta* 43:3359

VM

Electrochemical calorimetry — is the application of calorimetry to thermally characterize electrochemical systems. It includes several methods to investigate, for instances, thermal effects in batteries and to determine the \rightarrow *molar electrochemical Peltier heat*. Instrumentation for electrochemical calorimetric studies includes a calorimeter to establish the relationship between the amount of heat released or absorbed with other electrochemical variables, while an electrochemical reaction is taking place. Electrochemical calorimeters are usually tailor-made for a specific electrochemical system and must be well suited for a wide range of operation temperatures and the evaluation of the heat generation rate of the process. Electrochemical calorimeter components include a power supply, a device to control charge and discharge processes, ammeter and voltmeter to measure the current and voltage, as well as a computerized data acquisition system [i]. In situ calorimetry also has been developed for \rightarrow *voltammetry of immobilized particles* [ii, iii].

Refs.: [i] Redey L (1998) *Heat effects in batteries and measurements by electrochemical calorimetry*. The XIIIth Annual Battery Conference on Applications and Advances, Long Beach, Jan 13–16; [ii] Bărcena Soto M, Kubsch G, Scholz F (2002) *J Electroanal Chem* 528:18; [iii] Bărcena Soto M, Scholz F (2002) *J Electroanal Chem* 528:27

MBS

Electrochemical capacitor \rightarrow *capacitor*

Electrochemical cells (general aspects) — Electrochemical cells consist of at least two electron conductors (usually metals) in contact with ionic conductors (\rightarrow *electrolytes*). The current flow through electrochemical cells may be zero or non-zero. Electrochemical cells

with current flow can operate either as \rightarrow *galvanic cells*, in which chemical reactions occur spontaneously and chemical energy is converted into electrical energy, or as \rightarrow *electrolysis cells* (also called electrolytic cells), in which electrical energy is converted into chemical energy. In both cases part of the energy will be converted into (positive or negative) heat [i, ii].

Refs.: [i] Cohen ER, Cvitas T, Frey JG, et al. (eds) (2007) *IUPAC quantities, units and symbols in physical chemistry*, 3rd edn. RSC Publishing, Cambridge, p 82; [ii] Bard AJ, Faulkner LR (2001) *Electrochemical methods*. 2nd edn. Wiley, New York, pp 11–18

GI

Electrochemical cell (practical aspects) — A combination of two \rightarrow *electrodes* immersed in a solution. One electrode is called \rightarrow *cathode* and the other is \rightarrow *anode*. At the cathode a reduction process takes place and at the anode there is an oxidation. The overall redox reaction in a cell results in the \rightarrow *electromotive force (emf, voltage)*. Emf is the difference in the \rightarrow *electrode potentials* under the conditions of no current flow, see the figure. Electrochemical cells with current flow can operate either as \rightarrow *galvanic cells*, in which chemical reactions occur spontaneously and chemical energy is converted into electrical energy, or as \rightarrow *electrolytic cells*, in which electrical energy is converted into chemical energy. Galvanic cells are used to provide power to electrical devices. Some of them are rechargeable (see \rightarrow *batteries*), i.e., after discharging they can be charged again by appropriate polarization of the electrodes. The cells in which the burning reaction of a fuel (such as hydrogen or methanol) is completed are called \rightarrow *fuel cells*. The cells that employ enzymes as catalysts and bioorganic compounds as the substrates are called biocells. Electrolytic cells are often used to electrochemically synthesize a particular compound or to obtain a particular element. They are often used in science to generate a species for on-line physicochemical characterization. The anode and the cathode of a cell may be required to be placed in different solutions and then an electrolytic conductor, such as, e.g., a \rightarrow *salt bridge* is employed to make the electrical contact between them. Instead of a liquid solution, a conducting polymer or a solid electrolyte can be used in an electrochemical cell. Cells can have a variety of shapes and sizes.

Refs.: [i] Brett CMA, Oliveira Brett AM (1996) *Electrochemistry*. Oxford University Press, Oxford, chap 2; [ii] Kreysa G (1991) *Electrochemical cell design and optimization procedures*. Wiley-VCH

ZS

Channel flow electrochemical cell — A cell that is used in a flow system, where an examined liquid or

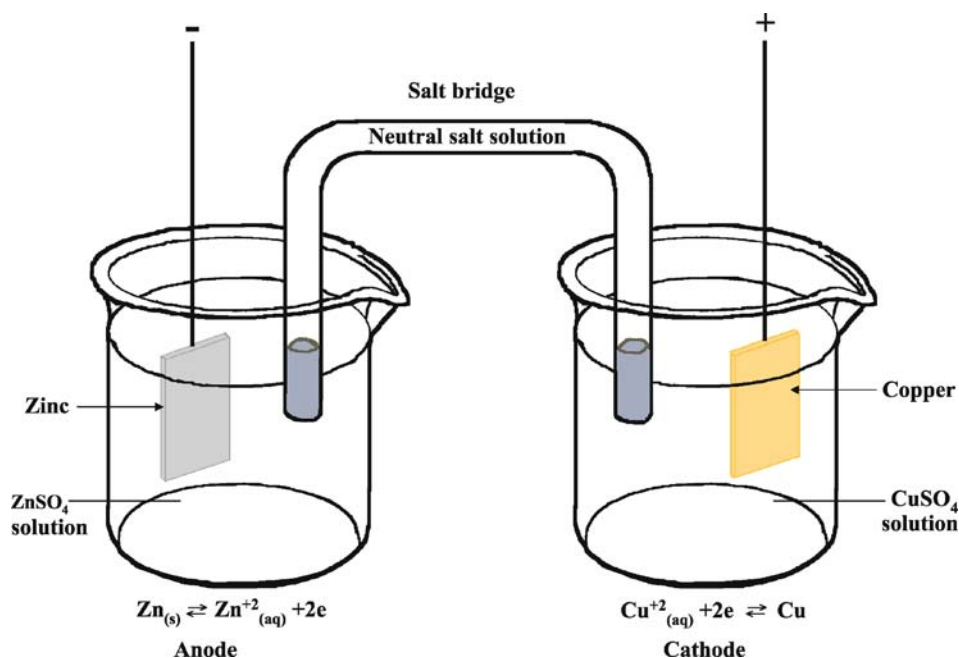

Electrochemical cell (practical aspects) — Figure. A simplified schematic picture for emf measurements. The → Daniell galvanic cell is shown

a conducting liquid into which an analyte is injected occasionally, flow in a channel (→ *hydrodynamic electrodes*). Most often, its duty is to be an electrochemical → *detector* for a particular analyte. Usually, a channel flow cell is a → *three electrode cell*; however, in some advanced applications more than one working electrode polarized independently are used. The electrodes can be mounted in the channel wall. They can also form an integral, separate cell into which a stream from the channel is delivered. The stream can be directed parallel, perpendicularly and at a given angle versus the surface of the → *working electrode*. Numerous types of → *modified electrodes* have been applied in channel flow cells.

Refs.: [i] Ewing AG, Mesaros JM, Gawin PF (1994) *Anal Chem* 66:527A; [ii] Tóth K, Štulík K, Kutner W, Fehér Z, Lindner E (2004) *Pure Appl Chem* 76:1119, [3] Trojanowicz M, Szweczyńska M, Wcisło M (2003) *Electroanalysis* 15:347; [iv] Mount AR (2003) *Hydrodynamic electrodes*. In: Bard AJ, Stratmann M, Unwin P (eds) *Instrumentation and electroanalytical chemistry. Encyclopedia of electrochemistry*, vol. 3. Wiley-VCH, Weinheim, pp 134

ZS

Three-electrode electrochemical cell (cell, system) — A cell where current flows between the → *working* and → *counter electrodes*. The third electrode, → *reference electrode*, is used to control the potential of the working electrode and to substantially limit the → *ohmic*

potential drop in the solutions, especially those of high resistivity. However, to have an ideal agreement between the instrumentally imposed potential and the true potential at the working electrode and to depress the ohmic potential drop to practically zero, additional hardware or software corrections must be employed. A three-electrode cell is usually required in the work with a → *potentiostat*.

Ref.: [i] Bard AJ, Faulkner LR (2001) *Electrochemical methods*. 2nd edn. Wiley, New York, pp 24–28

ZS

Voltage of an electrochemical cell — Difference between the potential of two → *electrodes* in an → *electrochemical cell*. In case of a → *three-electrode cell*, the potential difference between the → *working electrode* and the → *reference electrode*. The term ‘voltage’ is usually related to the nonequilibrium conditions, or to the conditions of → *current* flowing through the cell. The measured voltage includes the → *ohmic potential drop* and is affected by the concentration polarization, therefore the term “cell voltage” has no thermodynamic usefulness. To relate the cell voltage to the redox-reaction equilibrium it should be measured at → *open-circuit*, i.e., with no current flowing. Under such conditions the → *electromotive force (emf)* is obtained. The term cell voltage is often used in the literature instead of electromotive force and instead of cell potential.

Ref.: [i] Brett CMA, Oliveira Brett AM (1996) *Electrochemistry*. Oxford University Press, Oxford, pp 14–19

ZS

E

Electrochemical drilling → *electrochemical machining*

Electrochemical electromotive series → *potential*, and subentries → *standard potential*, and → *tabulated standard potentials*

Electrochemical element → *galvanic element*

Electrochemical equivalent — Amount of a chemical substance deposited, dissolved, or transformed in an electrochemical redox reaction with exchange of one unit of electric charge. In the SI unit system the electrochemical-equivalent unit is in kg C^{-1} , or alternatively, in mol C^{-1} . It means that in a n -electron redox reaction ($\text{Ox} + n\text{e}^- \rightleftharpoons \text{Red}$) the electrochemical equivalent is equal to the molar mass M of the reacting compound divided by n times the → *Faraday constant* (M/nF). In some sources the electrochemical equivalent is defined as the mass of the substance transformed by electric charge corresponding to the Faraday constant.

Ref.: [i] Bockris JO'M, Reddy AKN, Gamboa-Aldeco M (1998) *Modern electrochemistry*, vol. 1. Plenum Publishing Corporation, New York

MD

Electrochemical gas compressor — is a device with dense → *solid electrolyte membrane*, that increases the pressure of a gas due to passing direct → *current* between gas-permeable electrically conductive → *electrodes*. The operation principle relates to ionic transport through the membrane, driven by an applied electric field, with subsequent discharge and recombination. The direction and magnitude of the DC → *voltage* are imposed to overcome the counteracting driving force, namely the → *chemical potential* gradient. The advantages include an infinite theoretical selectivity, the possibility to combine → *electrolysis*, separation and compression processes, and the absence of moving parts and vibrations. Typical examples include the → *hydrogen* and → *oxygen* compressors where the membrane is made of proton and oxygen ion-conducting electrolytes, respectively [i, ii].

Refs.: [i] Joshi AV, Nachlas JA, Stuffle K (1991) *Int Patent Application* WO 91/06691; [ii] Drevet C, Henault M, Feger D, Fouletier J (1997) *A solid state electrochemical oxygen compressor*. In: Anderson HU, Khandkar AC, Liu M (eds) *Ceramic membranes I*. The Electrochemical Society, Pennington, pp 309–314

VK

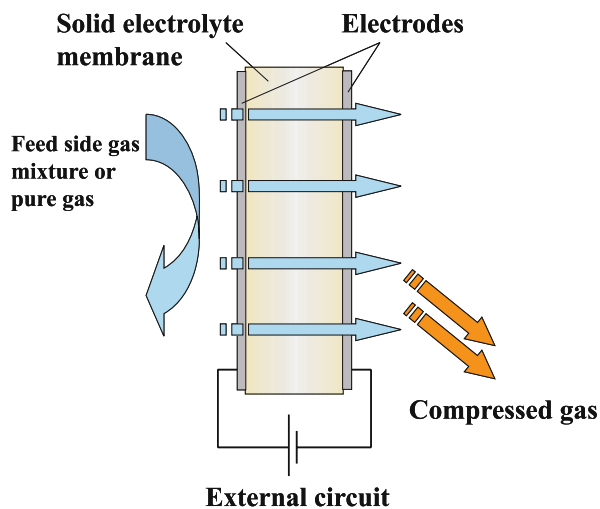

Electrochemical gas compressor — **Figure**. Schematic drawing illustrating the operation principles of electrochemical gas compressors

Electrochemical grinding → *electrochemical machining*

Electrochemical impedance spectroscopy — Experimental technique based on the measurement (under equilibrium or steady-state conditions) of the complex → *impedance* Z of the electrochemical system under study as a function of the frequency, f , or angular frequency $\omega = 2\pi f$, of an imposed sinusoidal perturbation of small amplitude (the term “spectroscopy” stems from this use of frequency as the variable) [i–iv]. The measurement is performed typically within a large range of frequencies covering several decades, from mHz (or sometimes even μHz) up to hundreds of kHz (or even MHz). Various coordinates are used for the graphical presentation of the measured impedance data, $Z(\omega)$ or $Z(f)$, for a set of frequencies, most frequently: 1) Plots of $Z' = \text{Re}Z$ and $Z'' = \text{Im}Z$ (here, $\text{Re}Z$ and $\text{Im}Z$ mean the real and imaginary parts of complex impedance Z , called sometimes “resistance” and “reactance”, respectively) as functions of frequency (usually, $\log f$). This presentation is rarely used now; 2) Plot of data for various frequencies as a set of points in the complex-impedance plane, with Z' and $-Z''$ as x and y axes, correspondingly (these graphs are called → *Nyquist diagrams* or → *complex plane plots*); 3) Graphs for $|Z|$ (“magnitude of impedance”) or $\log |Z|$ and $\arg Z$ as functions of $\log f$ (called → *Bode plot*); 4) Recalculation of the impedance data to yield various other complex characteristics, most frequently the → *admittance*, $Y = 1/Z$, and the complex capacitance, $C = Y/i\omega$ or $C = (i\omega(Z - R(\infty)))^{-1}$, where $R(\infty)$ is the limiting value of Z for high frequencies

(“high-frequency resistance”). Any of these functions of frequency can be plotted in the corresponding complex plane or in the Bode presentation: 5) 3D diagrams in which impedance values are plotted as a curve in three-dimensional space, e.g., with the use of coordinates Z' , $-Z''$ (or $\log Z'$, $\log(-Z'')$), $\log f$, with its projections to all three coordinate planes which are equivalent to the above presentations 1 and 2 [iv].

The interpretation of measured data for $Z(\omega)$ is carried out by their comparison with predictions of a theoretical model based either on the (analytical or numerical) integration of coupled charge-transport equations in bulk phases, relations for the interfacial charging and the charge transfer across interfaces, balance equations, etc. Another way of interpretation is to use an \rightarrow *equivalent circuit*, whose choice is mostly heuristic. Then, its parameters are determined from the best fitting of theoretically calculated impedance plots to experimental ones and the results of this analysis are accepted if the deviation is sufficiently small. This analysis is performed for each set of impedance data, $Z(\omega)$, measured for different values of external parameters of the system: bias potentials, bulk concentrations, temperature... The equivalent circuit is considered as appropriate for this system if the parameters of the elements of the circuit show the expected dependencies on the external parameters.

The traditional way is to measure the impedance curve, $Z(\omega)$, point-after-point, i.e., by measuring the response to each individual sinusoidal perturbation with a frequency, ω . Recently, nonconventional approaches to measure the impedance function, $Z(\omega)$, have been developed based on the simultaneous imposition of a set of various sinusoidal harmonics, or noise, or a small-amplitude potential step etc, with subsequent Fourier- and Laplace transform data analysis. The self-consistency of the measured spectra is tested with the use of the Kramers–Kronig transformations [iii, iv] whose violation testifies in favor of a non-steady state character of the studied system (e.g., in \rightarrow *corrosion*). An alternative development is in the area of impedance spectroscopy for nonstationary systems in which the properties of the system change with time.

Refs.: [i] Bard AJ, Faulkner LR (2001) *Electrochemical methods*. 2nd edn. Wiley, New York; [ii] Macdonald JR (ed) (1987) *Impedance spectroscopy. Emphasizing solid materials and systems*. Wiley, New York; [iii] Retter U, Lohse H (2005) *Electrochemical impedance spectroscopy*. In: Scholz F (ed) *Electroanalytical methods*. Springer, Berlin; [iv] Barsoukov E, Macdonald JR (ed) (2005) *Impedance spectroscopy. Theory, experiment, and applications*. Wiley, Hoboken

MAV

Electrochemical immunoassay \rightarrow *immunoassay, electrochemical*

Electrochemical irreversibility \rightarrow *reversibility*

Electrochemical machining — Electrochemical machining (ECM, also electrochemical shaping, - grinding, - drilling, - sinking) is a special technique to structure and smooth metallic materials, especially steel. The fundamental process is similar to \rightarrow *electropolishing*. The ECM process consists of the anodic dissolution of a work-piece with an especially formed cathode at large current densities. The \rightarrow *cathode* is progressively advanced so that a constant interelectrode gap of some ten to some hundred μm is maintained and a negative of the cathode's shape is reproduced on the work-piece. Extremely large current densities of 1 to 10 MA m^{-2} are necessary to achieve sufficiently high machining rates around one mm per minute and to suppress oxygen evolution. Most common electrolytes are aqueous solutions of NaNO_3 or NaCl . Due to the high dissolution rates electrolyte flow rates of about 10 m s^{-1} are required to avoid local electrical heating and to remove the products such as hydroxides and gas bubbles. ECM was developed in the fifties, mainly for aerospace industries but is now used wherever parts of extremely high quality and complex shape are needed. Typical products range from turbine blades, valve seats, nozzles, gear components, casting moulds and (electric) shaver caps, to medical implants. The advantages of ECM are obvious: almost no tool wear (cathode), almost forceless machining, no thermally influenced machining zones, and smooth surfaces without additional process steps. Pulsed currents yield a better accuracy and surface quality. Disadvantages are the expenses for electric energy and recycling of the product solutions. ECM was initially developed to shape steel parts, but also alloys of Al and Ti as well as hard metals can be machined.

Refs.: [i] Faust CL (1971) *Fundamentals of electrochemical machining*. The Electrochemical Society, Princeton; [ii] McGeough JA (1974) *Principles of electrochemical machining*. Chapman & Hall, London; [iii] McGeough JA (1988) *Advanced methods of machining*. Chapman & Hall, London; [iv] McGeough JA (2005) *Electrochemical machining (ECM) In: Kirk-Othmer (ed) Encyclopedia of chemical technology*, 4th edn., vol. 15. Wiley-Interscience, New York, pp 608–622; [v] Landolt D, Chauvy PF, Zinger O (2003) *Electrochim Acta* 48:3201

MML

Electrochemical nose — (‘electronic nose’, ‘e-nose’, or ‘artificial nose’) is an array of chemical and/or \rightarrow *electrochemical sensors* mimicking the physiological olfac-

tory receptors. The e-nose comprises a sampling system, an array of the respective chemical and/or electrochemical sensors with differing selectivity, and a computer with appropriate pattern recognition and classification algorithms. In a broader meaning, analytical data supplied by e.g., calorimetric, surface acoustic wave, or even mass spectrometric, GC, or IR measurements can also be processed in the e-nose like manner, but the common definition refers to a sensing system powered by tiny chemical sensors applied to detect, identify, and quantify gas \rightarrow *analytes*. Since the physiological nose as archetype is addressed, the instrument e.n. combines mainly \rightarrow *gas sensors*, capable of the quantitative or semi-quantitative analysis of simple or complex gases, vapors, or odors. Typically, a common up-to-date e-nose system comprises 4 to 20 (electro)chemical gas sensors, as e.g. for hydrogen cyanide, methyl isocyanate, nitrogen dioxide, carbon monoxide, sensitive in the range of 0 to 1000 ppm. Most often, amperometric gas sensors (AGS) are utilized. Chemoresistors based on metal-oxides (metal oxide semiconductor, MOS) or \rightarrow *conducting polymers*, and mass transducers as the \rightarrow *quartz crystal microbalance* are widely used. The sensors are mostly nonselective; so the data output must be processed through a certain pattern algorithm. Finally, the chemical compound is identified by a pattern of the outputs given by the different sensors. Nowadays, a certain number of state-of-the-art e-noses are commercially available to perform comparisons of unknown gas, vapor, and odor samples with a calibration library provided by the manufacturer and/or created and updated by the user.

Refs.: [i] Gardner JW, Bartlett PN (1999) *Electronic noses: Principles and applications*. Oxford University Press, Oxford; [ii] Dickinson TA, White J, Kauer JS, Walt DR (1998) *Trends Biotechnol* 16:250

MHer

Electrochemical oscillations — Chemical reacting systems can exhibit a rich variety of spatio-temporal self-organization if they are governed by appropriate non-linear evolution laws. The non-equilibrium thermodynamic theory, particularly the theory of dissipative structure was elaborated by \rightarrow *Prigogine*. Although the phenomenon of spontaneous oscillations had been observed even in the nineteenth century, they were regarded as curiosities. The scientific exploration of this field started in the 1970s, and its results induced a new thinking not only in science but also in society. Abundant experimental material has been collected and significant progress has been made regarding the theoretical understanding of chemical instabil-

ities, oscillations, complex dynamical bifurcations, and chaos [i].

Nonsteady behavior of electrochemical systems was observed by \rightarrow *Fechner* as early as 1828 [ii]. Periodic or chaotic changes of \rightarrow *electrode potential* under \rightarrow *galvanostatic* or open-circuit conditions and similar variation of \rightarrow *current* under \rightarrow *potentiostatic* conditions have been the subject of numerous studies [iii, iv]. The electrochemical systems, for which interesting dynamic behavior has been reported include anodic or open-circuit dissolution of metals [v–vii], electrooxidation of small organic molecules [viii–xiv] or hydrogen, reduction of anions [xv, xvi] etc. [ii]. Much effort regarding the theoretical description and mathematical modeling of these complex phenomena has been made [xvii–xix]. Especially studies that used combined techniques, such as radiotracer (\rightarrow *tracer methods*)(Fig. 1) [x], \rightarrow *electrochemical quartz crystal microbalance* (Fig. 2) [vii, xi], \rightarrow *probe beam deflection* [xiii], \rightarrow *surface plasmon resonance* [xvi] surface stress [xiv] etc. have contributed considerably to the elucidation of the role of chemisorbed species (\rightarrow *chemisorption*), surface reconstruction as well as \rightarrow *transport phenomena* in the mechanism of oscillations.

There are different types of electrochemical oscillations and also several views regarding the origin of these phenomena.

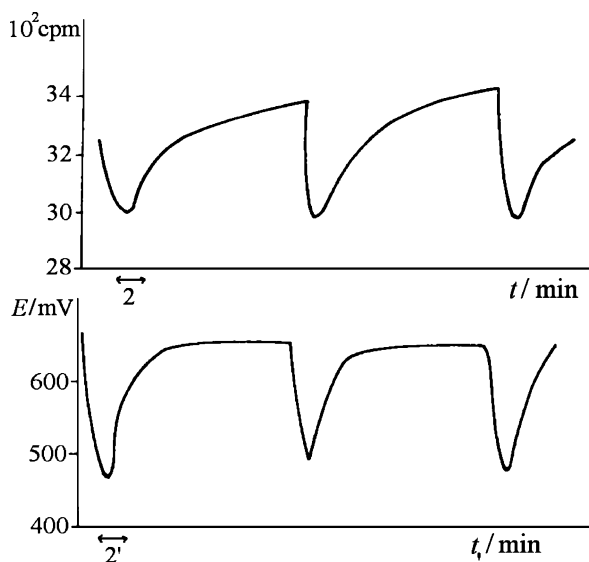

Electrochemical oscillations — Figure 1. Potential oscillations and periodical changes in the count rate, i.e., Cl^- adsorption in the course of galvanostatic electrooxidation of glyoxal. Pt electrode ($A = 13 \text{ cm}^2$), $I = 0.3 \text{ mA}$. Solution: 0.4 mol dm^{-3} glyoxal + 1 M HClO_4 + $10^{-4} \text{ mol dm}^{-3} \text{ H}^{36}\text{Cl}$ [x]

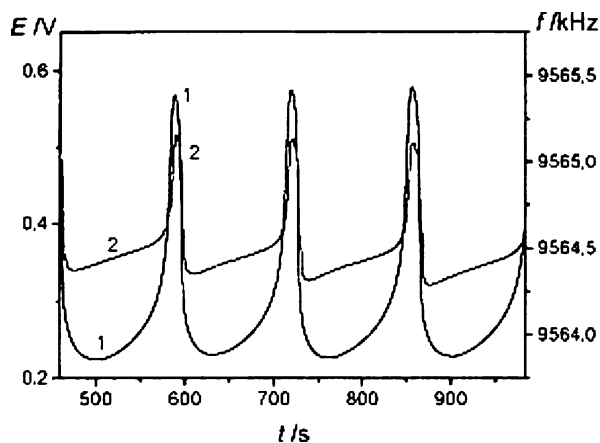

Electrochemical oscillations — Figure 2. Potential oscillations (1) and the simultaneously measured changes of the \rightarrow EQCM frequency response (2), i.e., the variation of the surface mass, in the course of galvanostatic electrooxidation of formic acid at a Pt electrode ($A = 0.3 \text{ cm}^2$). $I = 0.45 \text{ mA}$. Solution: $0.5 \text{ mol dm}^{-3} \text{ HCOOH} + 1 \text{ mol dm}^{-3} \text{ HClO}_4$ [xi]

The electrical engineering approach considers a negative \rightarrow impedance element which can influence a circuit's stability. In several cases such a negative impedance clearly appears in the \rightarrow polarization curve, i.e., by increasing the potential the current decreases; a typical example is the \rightarrow passivation of metals. In contrast with the regular polarization behavior when the relationship between the potential and the current is unambiguous and they mutually determine each other, in the course of the dissolution of a passivating metal the same current density belongs to three potential values. Surprisingly, the potential oscillations are relatively rare in these systems, and the periodic or chaotic behaviors have been observed for many other \rightarrow electrochemical processes when no negative impedance could be seen in the I vs. E curves. For this case the term, hidden negative impedance has been introduced.

However, the reason of the appearance of negative impedance is always a chemical/electrochemical process. In most cases the blocking (inactivation) of the electrode (metal) surface is the pivotal (autoinhibition) step in the mechanism behind the emergence of the oscillating behavior. The blocking can be a consequence of adsorption of ions or molecules, chemisorption of molecular fragments, deposition of metals, salts or other compounds, formation of oxide layer etc. In all cases several coupled, consecutive, and simultaneous processes occur. The oscillating behavior appears only at a certain set of parameters (concentrations of the electrochemically active species, the nature and the concen-

tration of the supporting electrolyte, stirring rate, the value of the galvanostatically regulated current, or the value of the potentiostatically controlled potential etc.). For instance, in the case of the oxidation of formic acid at a platinum electrode – which is a good example for the electrocatalytic oxidation of other small organic molecules – the following steps have to be considered.

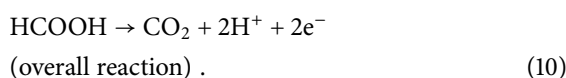
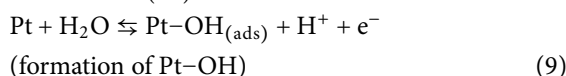
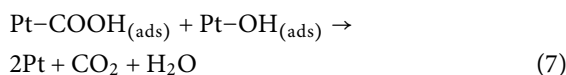
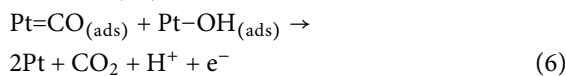
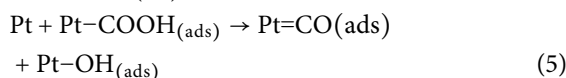
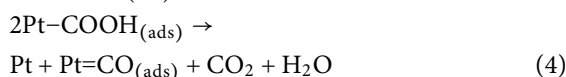
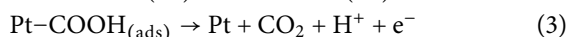

In the case of galvanostatic ($I = \text{constant}$) oxidation the total current (I) is a sum of partial currents. Under steady-state conditions

$$I = I_1 + I_2 + I_3, \quad (11)$$

where I_1 belongs to the direct oxidation or the oxidation of the loosely adsorbed species [Eqs. (10) and (8)], I_2 is the current accompanying the chemisorption process [Eq. (2)], and I_3 is the current belongs to the oxidation of chemisorbed molecular fragments [Eqs. (3) and (6)].

In the case of oscillation all partial currents will be functions of potential and time, and the \rightarrow capacitive current has to be taken into account, too:

$$I = I_1(E, t) + I_2(E, t) + I_3(E, t) + C \frac{\partial E}{\partial t}. \quad (12)$$

On the basis of the rate equations, differential equations can be set up. Due to the adsorption/chemisorption and feedback steps the solution of this set of differential equations is periodic or chaotic. Usually the occurrence of adsorption/chemisorption leads to nonlinearity and negative impedance.

In addition to Eqs. (1)–(9) the rate of the transport processes should also be considered. Phenomenologically the following explanation can be given. If the measurement is started by using a clean platinum surface after the addition of HCOOH, depending on the rates of the transport processes and the adsorption, the surface will be covered by adsorbed HCOOH [Eq. (1)]. The adsorption is quickly followed by the chemisorption step [Eq. (2)]. It can easily be observed if HCOOH is added to the supporting electrolyte at open-circuit since a fast decrease of the potential occurs due to the formation of a \rightarrow *hydrogen electrode*:

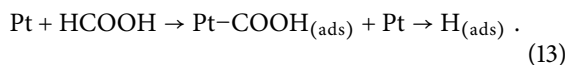

However, if $I > 0$ is applied Pt–H will be quickly oxidized:



The surface will be gradually covered with chemisorbed molecular fragments, consequently the potential will increase in order to maintain the constant reaction rate, i.e., the galvanostatically imposed constant current. Eventually the potential reaches a value where the oxidation of the chemisorbed species starts, either by direct electron transfer or by surface reaction with Pt–OH which is also formed at high enough potentials. At the clean platinum surface formed again the oxidation of formic acid can proceed with the forced rate at a much lower potential, consequently the potential drops and the whole process starts again. The phenomenon described can also be seen in the cyclic voltammograms. During positive-going scan on the blocked surface a small oxidation peak develops, while during the negative-going scan a much higher anodic (and not cathodic) peak appears [viii–xi]. In the reaction scheme there are feedback and autocatalytic steps [Eqs. (4), (6), and (7)]. The most important autocatalytic steps are those in which two free Pt sites are liberated due to the surface reactions.

Other effects such as surface inhomogeneities and surface reconstruction can also be considered. In the case of oxidation of H₂, electroadsorbed anions or cations can act as inhibitors. During the oxidation of metals the formation of surface oxides or salts plays the most important role. For instance, the following model describes

copper electrodisolution in acidic chloride media:

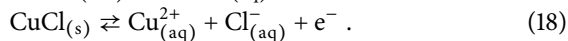
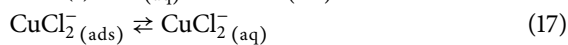
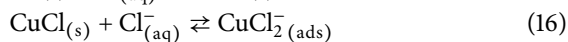
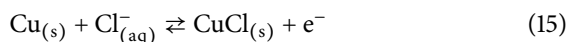

There is another type of oscillation which is a consequence of the \rightarrow *Frumkin effect*. A typical example is the reduction of S₂O₈²⁻ at Cu or Ag electrodes [xv, xvi].

The periodic-chaotic behavior is not only a theoretically interesting phenomenon but also has practical importance, e.g., regarding the functioning of \rightarrow *fuel cells* [xx].

A nice classroom experiment is the \rightarrow *beating mercury heart*.

Refs.: [i] Scott SK (1991) *Chemical chaos*. Clarendon Press, Oxford; [ii] Fechner GT (1828) *Schweigg J f Chem Phys* 53:129; [iii] Wojtowicz J (1972) *Oscillatory behaviour in electrochemical systems*. In: Bockris JO'M, Conway BE (eds) *Electrochemical oscillations*. vol. 8. Plenum Press, New York; [iv] Hudson JL, Tsotsis TT (1994) *Chem Eng Sci* 49:1493; [v] Hudson JL, Bassett MR (1991) *Oscillatory electrodisolution of metals*. In: Luss D, Amundson NR (eds) *Reviews in chemical engineering*. Freund, London; [vi] Albahadily IN, Schell M (1991) *J Electroanal Chem* 308:151; [vii] Inzelt G (1993) *J Electroanal Chem* 348:465; [viii] Buck RP, Griffith LR (1962) *J Electrochem Soc* 109:1005; [ix] Horányi G, Inzelt G, Szetey E (1977) *J Electroanal Chem* 81:395; [x] Horányi G, Inzelt G (1978) *J Electroanal Chem* 87:423; [xi] Inzelt G, Kertész V, Láng G (1993) *J Phys Chem* 97:6104; [xii] Schell M, Albahadily FN (1989) *J Chem Phys* 90:822; [xiii] Kertész V, Inzelt G, Barbero C, Kötz R, Haas O (1995) *J Electroanal Chem* 392:91; [xiv] Láng GG, Ueno K, Ujvári M, Seo M (2000) *J Phys Chem B* 104:2785; [xv] Wolf W, Ye J, Purgand M, Eiswirth M, Doblhofer K, Ertl G (1992) *Ber Bunsenges Phys Chem* 96:1797; [xvi] Flätgen G, Krischer K, Ertl G (1996) *J Electroanal Chem* 409:183; [xvii] De Levie R (1970) *J Electroanal Chem* 25:257; [xviii] Koper MTM, Sluyters JH (1993) *J Electroanal Chem* 347:31, 352:51; [xix] Koper MTM (1996) *Oscillations and complex dynamical bifurcations in electrochemical system*. In: Prigogine I, Rice SA (eds) *Advances in chemical physics*, vol. 92. Wiley, New York, pp 161–298; [xx] Zhang J, Datta R (2002) *J Electrochem Soc* 149:A1423

GI

Electrochemical Peltier heat \rightarrow *molar electrochemical Peltier heat*

Electrochemical pile — Historic name for a \rightarrow *battery* with a series of \rightarrow *electrochemical cells* arranged in form of a pile. The name has been also used for other multi-cell arrangements. See also \rightarrow *Carré pile*, \rightarrow *Cruikshank pile*, \rightarrow *dry pile*, \rightarrow *Grenet-Jarriant pile*, \rightarrow *Muirhead pile*,

→ Thomson (William th.) pile, → Tommasi pile, → Trouvé pile, → Wollaston pile, → Volta pile, → Zamboni pile.

FS

Electrochemical plating → *electroplating*

Electrochemical polymerization → *electropolymerization*

Electrochemical polishing → *electrochemical machining*

Electrochemical potential — (SI unit: J mol⁻¹) The notion introduced by → Butler [i] and Guggenheim [ii] for consideration of equilibria in electrochemical systems with participation of charged species on the basis of the relationship for the electrochemical → Gibbs energy \bar{G} :

$$d\bar{G} = -S dT + V dp + \sum_i \mu_i dN_i + F \sum_i z_i \varphi dN_i, \quad (1)$$

where S is the entropy, V is the volume of the system, T and p are its temperature and pressure, μ_i is the → chemical potential of the i -th species, N_i is a number of moles of the i -th component, z_i is the charge of the i -th species taking regard of its sign, and φ is the electrical potential in the location point of the i -th species, which is also called the → inner electric (or internal electric) potential (→ potential) of the corresponding phase. According to Eq. (1), the electrochemical potentials of the components, $\bar{\mu}_i$, are characteristic values for the i -th species in any phase α under consideration:

$$\bar{\mu}_i^\alpha = \mu_i^\alpha + z_i F \varphi^\alpha = \left(\frac{\partial \bar{G}}{\partial N_i} \right)_{p, T, N_{j \neq i}}. \quad (2)$$

Only these values or the differences of electrochemical potentials referred to phases α and β

$$\bar{\mu}_i^\beta - \bar{\mu}_i^\alpha = \left(\mu_i^\beta - \mu_i^\alpha \right) + z_i F \left(\varphi^\beta - \varphi^\alpha \right) \quad (3)$$

are experimentally available. For equilibrium conditions, $\bar{\mu}_i^\alpha = \bar{\mu}_i^\beta$. The properties of the electrochemical potential for various particular cases are considered in [iii], IUPAC recommendations are available in [iv].

Refs.: [i] Butler JAV (1926) *Proc R Soc London* 112A:129; [ii] Guggenheim EA (1929) *J Phys Chem* 33:842; [iii] Bard AJ, Faulkner LR (2001) *Electrochemical methods*, 2nd edn. Wiley, New York, pp 60–62; [iv] Parsons R (1974) *Pure Appl Chem* 37:503

GT, OP

Electrochemical promotion → NEMCA

Electrochemical quartz crystal microbalance (EQCM)

— Electrochemical quartz crystal microbalance (EQCM) or nanobalance (EQCN) is a combination of a piezoelectric sensor, i.e., a → quartz crystal microbalance (QCM) and an → electrochemical cell containing the sample electrolyte solution, the → reference electrode, as well as other electrodes as required, driving oscillator, amplifiers, and readout units [i–iv]. In most electrochemical experiments, the piezoelectric crystal, usually a quartz crystal plate, with attached electronic and occasionally selective surface films [iii], [iv] is clamped between two O-rings or is mounted in other suitable holders. Generally, only one crystal face and one oscillator electrode in the electrochemical cell, are in contact with the sample solution. The AC excitation voltage can be easily separated electronically from the DC potential that is applied to carry out electrochemical investigations. In this way, the surface mass change (Δm) occurs during any electrochemical experiments, e.g., galvanostatic, potentiostatic, cyclic voltammetry, can be followed by detecting the frequency changes (Δf). The electrochemical data, e.g., the charge (Q) consumed can be correlated with the frequency (mass) changes, and – if the requirements of the accurate QCM measurements, e.g., uniform distribution of the added mass, elastic behavior, are met as well as the charge efficiency is 100% – the molar mass (M) of the depositing or exchanged species can be calculated in a simple manner:

$$M = \frac{nFA\Delta f}{C_f Q}, \quad (1)$$

where A is the surface area, C_f is the integral mass sensitivity, F is the → Faraday constant, and n is the number of electrons transferred. For cyclic voltammetric experiment the corresponding relationship between the current (I) and the frequency change is as follows:

$$I = \frac{nF\nu}{C_f M} \frac{d(\Delta f)}{dE}, \quad (2)$$

where ν is the scan rate, $d(\Delta f)/dE$ is the derivative of Δf with respect to potential.

It is useful to calibrate the EQCM, i.e., to determine C_f , e.g., by electrodeposition and electrodisolution of silver. The rigidity layer behavior can be tested by depositing films of different thicknesses. Usually relatively thin films (10 nm–some hundreds nm) show rigid layer behavior. The deviation from linearity regarding the Δm vs. Q function is related to the appearance of the viscoelastic effect. By the help of impedance measurements

the viscoelastic characteristics of the surface film can also be tested [v–vii]. In the absence of any deposition, the change of the density and viscosity in the double layer or in the diffusion layer may cause 0.1–10 Hz frequency change. It may interfere with the effect caused by the deposition of monolayers or submonolayers. In some cases other effects, e.g., stress, porosity, pressure, and temperature should also be considered.

EQCM can be combined with other techniques, e.g., with → *probe beam deflection (PBD)* [viii], radiotracer methods (→ *tracer methods*) [ix], and → *scanning electrochemical microscopy* [x].

The concept and instrumentation of AC electrogravimetry has also been developed [xi]. By the help of the combined technique the overall mass effect, which can be measured by EQCM, can be deconvoluted, i.e., the transport and sorption of different ionic and neutral species can be separated. The EQCM technique has become a widely used technique in several areas of electrochemistry, electroanalytical chemistry, bioelectrochemistry etc. Obviously, mass changes occurring during → *adsorption*, sorption, → *electrosorption*, → *electrodeposition*, or spontaneous deposition can be followed which is very helpful for the elucidation of reaction mechanisms via identification of the species accumulated on the surface. These investigations include → *metal deposition* and → *alloy deposition*, → *underpotential deposition*, → *electroplating*, synthesis of → *conducting polymers* by → *electropolymerization*, adsorption of biologically active materials, analytical determination of small ions and biomolecules etc. Of course, the opposite process of spontaneous dissolution, → *electrodisolution*, → *corrosion* can also be studied. → *Electrochemical oscillations*, in which the formation and oxidation of chemisorbed molecular fragments play a determining role, have been studied, too. The majority of the investigations have been devoted to ion and solvent transport associated with the redox transformations of electrochemically active polymers. Similar studies have been carried out regarding polynuclear surface layer such as metal hexacyanometalates as well as inorganic and organic microcrystals of different compositions.

The method of piezoelectric microgravimetry (nanogravimetry) at an EQCM can be considered as a novel and highly sensitive version of → *electrogravimetry*.

Refs.: [i] Buttry DA (1991) *Applications of the quartz crystal microbalance to electrochemistry*. In: Bard AJ (ed) *Electroanalytical chemistry*, vol. 17. Marcel Dekker, New York, pp 1–85; [ii] Buck RP, Lindner E, Kutner W, Inzelt G (2004) *Pure Appl Chem* 76:1139; [iii] Buttry DA, Ward MD (1992) *Chem Rev* 92:1355; [iv] O'Sullivan CK, Guilbault

(1999) *Biosens Bioelectron* 14:663; [v] Hepel M (1999) *Electrode-solution interface studied with electrochemical quartz crystal nanobalance*. In: Wieczkowski A (ed) *Interfacial electrochemistry*. Marcel Dekker, New York, pp 599–630; [vi] Hillman AR (2003) *The Electrochemical quartz crystal microbalance*. In: Bard AJ, Stratmann M, Unwin PR (eds) *Instrumentation and electroanalytical chemistry. Encyclopedia of electrochemistry*, vol. 3. Wiley-VHC, Weinheim, pp 230–289; [vii] Tsionsky V, Daikhin L, Urbakh M, Gileadi E (2004) *Looking at the metal/solution interface with electrochemical quartz-crystal microbalance: Theory and experiment*. In: Bard AJ, Rubinstein I (eds) *Electroanalytical chemistry*, vol. 22. Marcel Dekker, New York, pp 2–94; [viii] Vilas-Boas M, Henderson MJ, Freire C, Hillman AR, Vieil E (2000) *Chem Eur J* 6:1160; [ix] Inzelt G, Horányi G (1989) *J Electrochem Soc* 136:1747; [x] Gollas B, Bartlett PN, Denuault (2000) *Anal Chem* 72:349; [xi] Gabrielli C, Keddam M, Perrot H, Torresi R (1994) *J Electroanal Chem* 378:85

GI

Electrochemical quasireversibility → *reversibility*

Electrochemical reversibility → *reversibility*

Electrochemical sensors — Electrochemical sensors belong to the family of chemical sensors. Chemical sensors are devices that convert chemical information (concentration, → *activity* or partial pressure of the analyte) into a measurable signal. Chemical sensors contain two basic functional units: a receptor and a transducer. The receptor interacts with the analyte and transforms chemical information into a form of energy that is converted further by the transducer into a useful analytical signal.

Chemical sensors may be classified according to the operating principle of the transducer. Based on this classification, electrochemical sensors are such chemical sensors where the chemical information is transduced into an electrical signal. Electrochemical sensors can be divided further into → *amperometric sensors*, → *conductimetric sensors*, and → *potentiometric sensors*, depending on which electrical property is actually recorded.

Commonly used electrochemical sensors include → *amperometric sensors* for monitoring of carbon monoxide in air, dissolved oxygen in water (→ *Clark electrode*), or glucose in blood, → *conductimetric sensor(s)* for detection of reducing gases in air (→ *Taguchi sensor*), and → *potentiometric sensors* for determining oxygen in the gas phase (→ *lambda probe*) or ions in water (→ *pH-sensitive electrodes*, → *ion-selective electrodes*). Electrochemical sensors are the largest and oldest group of chemical sensors. For characteristics of sensors see also → *response time*, and → *response volume*.

Refs.: [i] Janata J (1989) *Principles of chemical sensors*. Plenum, New York; [ii] Göpel W, Hesse J, Zemel JN (1991) *Sensors – A comprehen-*

sive survey, vol. 2. VCH, Weinheim; [iii] Hulanicki A, Glab S, Ingman F (1991) *Pure Appl Chem* 63:1247

JB

Electrochemical shaping → *electrochemical machining*

Electrochemical Society, The — The Society (acronym ECS) – originally called the American Electrochemical Society – was founded in 1902 in Philadelphia. The international nature of the Society was officially recognized by dropping “American” from the name in 1930. Its first meeting was held in Philadelphia on April 3, 1902 where Joseph W. Richards, a professor of metallurgy at Lehigh University was elected president. Its journal, the *Transactions of the American Electrochemical Society* appeared also in 1902. The *Journal of the Electrochemical Society* debuted in January 1948; and publication of *Transactions* was discontinued after the 1949 issues. In 1915 ten divisions were established: Primary Batteries, Secondary Batteries, Electric Furnaces, Electrolysis, Electroanalysis, Electrometallurgy, Electroplating, Radioactivity, Chlorine and Caustic, and Experimental and Theoretical Electrochemistry. High Temperature Materials Division in 1921; the Electronics Division in 1931, the Physical Electrochemistry Division in 1936, the Organic and Biological Electrochemistry Division in 1940, the Corrosion Division in 1942, the Industrial Electrolysis and Electrochemical Engineering Division in 1943, the Dielectric Science and Technology Division in 1946, Battery Division in 1947, Luminescence and Display Materials in 1982, Energy Technology Division in 1987, Sensor Division 1988, Fullerene Division in 2002, respectively, were founded. Beside the *Journal of Electrochemical Society*, the Society publishes two more journals: *Electrochemical and Solid State Letters* (from 1998) and *Interface* (launched in 1992) as well as proceedings, handbooks, and monographs. The membership of the Society stands around 8.000. The ECS organizes meetings twice a year.

The address of The Electrochemical Society, Inc. is 65 South Main Street, Pennington, NJ 08534 – 2839, U.S.A. Web: <http://www.electrochem.org>.

Ref.: [i] *Interface (The Electrochemical Society) Special Centennial Issue ECS at 100 (2002) 11(1)*, pp 22–37

GI

Electrochemical surface plasmon resonance, ESPR
→ *plasmon resonance*

Electrochemical surface science → *surface analytical methods*

Electrochemical switching — takes place when the two redox states of a compound possess such different binding properties for a target species (cations, anions, or molecules) that one can regard the change as a switching from one state to another. When $\text{Ox} + ne^- \rightleftharpoons \text{Red}$ is the electrochemical → *equilibrium* between the oxidized and reduced state of the free host (with the formal → *potential* $E_{c(\text{Ox}/\text{Red})}^{\ominus'}$), and both redox species form complexes with the guest ion Y according to $\text{Ox} + Y \rightleftharpoons \text{OxY}$, and $\text{Red} + Y \rightleftharpoons \text{RedY}$, and with the corresponding stability constants $K_{\text{OxY}} = a_{\text{OxY}} / (a_{\text{Ox}} a_{\text{Y}})$ and $K_{\text{RedY}} = a_{\text{RedY}} / (a_{\text{Red}} a_{\text{Y}})$, the following relation holds: $K_{\text{RedY}} / K_{\text{OxY}} = \exp \left[-F \left(E_{c(\text{Ox}/\text{Red})}^{\ominus'} - E_{c(\text{OxY}/\text{RedY})}^{\ominus'} \right) / RT \right]$. Here, $E_{c(\text{OxY}/\text{RedY})}^{\ominus'}$ is the formal potential of the redox couple OxY/RedY . Electrochemical switching has received much attention with respect to anion and cation recognition, analytical applications, biomimetics of ion transport through → *membranes*, and generally molecular recognition.

Ref.: [i] Kaifer AE, Gómez-Kaifer M (1999) *Supramolecular electrochemistry*. Wiley-VCH, Weinheim

FS

Electrochemical synthesis → *electrosynthesis*

Electrochemical wastewater treatment — may involve (a) → *electrolysis* with the purpose of heavy metal ion removal, (b) electrochemical transformation of anions, e.g., perchlorate, nitrate, (c) oxidation of organic pollutants, (d) → *electrodialysis*, or (e) → *capacitive deionization*.

Ref.: [i] Wendt H, Kreysa G (1999) *Electrochemical engineering, science and technology in chemical and other industries*. Springer, Berlin; [ii] Martínez-Huitle CA, Ferro S (2006) *Chem Soc Rev* 35:1324

FS

Electrochemical window — In electrochemical experiments the range of potentials that is accessible without appreciable current flow, i.e., the potential range in which the electrode may be considered “perfectly polarizable”. Electrochemical windows depend on the → *electrode material*, the → *solvent*, and the → *electrolyte*. There is no strict definition for the current density defining the potential limits of the electrochemical window. That depends on the experiment, i.e., the signals to be measured. For highly sensitive measurements of very low current densities, the acceptable current densities at the potential limits are much smaller than in cases where high current density signals are measured. The electrochemical window also depends very much on impurities, e.g., traces of water in nonaqueous solvents, or traces of transition metal ions in aqueous electrolyte solutions. The

latter may act as electrocatalysts (\rightarrow *electrocatalysis*) increasing the current densities at the limits of the electrochemical window. The electrochemical window is generally defined by the electrochemical processes starting at the negative and positive end of the potential window. In an aqueous solution of KCl, and for a mercury electrode, the anodic limit is given by the anodic oxidation of mercury to calomel Hg_2Cl_2 (that limit depends on the chloride activity), and the cathodic limit is given by the cathodic reduction of potassium ions and the formation of potassium amalgam (that process limit depends on the potassium activity).

E

Electrochemically active polymer films \rightarrow *conducting polymers*

Electrochemically stimulated conformational relaxation model (ESCR model) — This model [i, ii] describes the relaxation phenomena occurring during the charging and discharging of \rightarrow *conducting polymers*. It assumes that applying an anodic \rightarrow *overpotential* to a neutral conjugated polymer, as a first step, an expansion of the closed polymeric structure occurs. In this way, partial oxidation takes place and counter ions from the solution enter the solid polymer under the influence of an electrical field at those points of the polymer/electrolyte

interface where the structure is less compact. This is the \rightarrow *nucleation* process. Then the oxidized sphere expands from these points towards the polymer/metal interface and grows parallel to the metal surface. The rate of this part of overall reaction is controlled by a structural relaxation involving conformational changes of polymer segments and a swelling of the polymer due to electrostatic repulsions between the chains and to incorporations of counter ions (see Fig.). The oxidation process is completed by the \rightarrow *diffusion* of counter ions through the already opened structure of the polymer. During reduction, opposite processes occur. The positive charges on the polymers are neutralized and counter ions are expelled. Reverse conformational changes lead to a shrinking of the polymer. Diffusion of the counter ions becomes more and more difficult. The structure is closing. The compaction of this closing step depends on the cathodic potential applied to the polymer and will be more efficient at more negative potentials. The compact structure hinders counter ion exchange with the solution. A quantitative expression for the relaxation time τ needed to open the closed polymer structure is given by the following expression:

$$\tau = \tau_0 \exp[\Delta H^* + z_c(E_s - E_c) - z_r(E - E_0)],$$

where ΔH^* is the conformational energy consumed per mole of polymeric segments in absence of any ex-

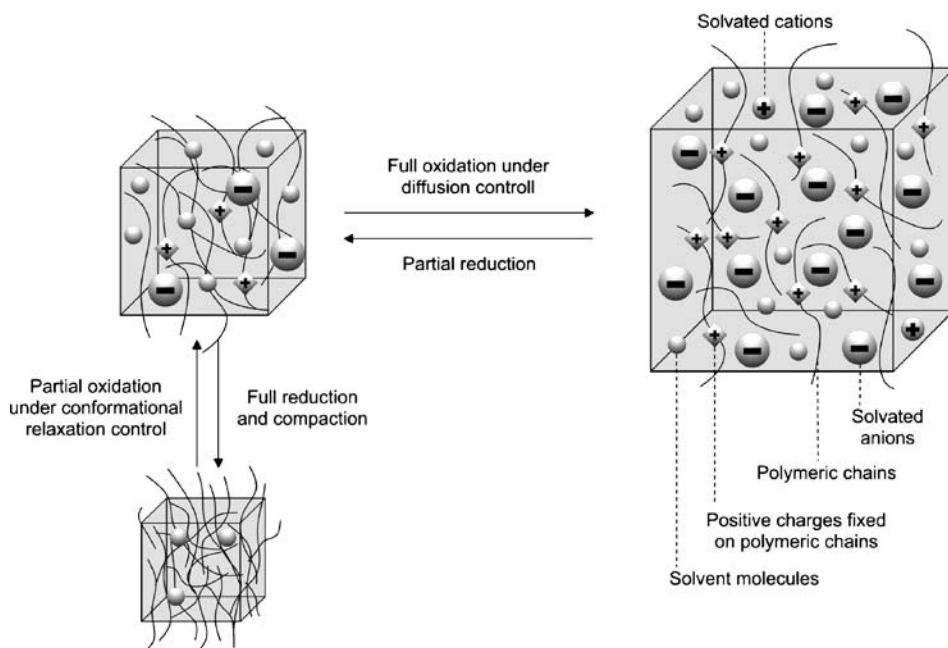

Electrochemically stimulated conformational relaxation model (ESCR model) — Figure

ternal electrical field, the second term $z_c (E_s - E_c)$ is the energy to reduce, close, and compact one mole of polymeric segments with E_s = experimental potential of closure and E_c = compaction potential, and finally the last term $z_r (E - E_o)$ represents the energy required to open the closed structure. (z_r = charge consumed to relax one mol of polymeric segments; τ_o = relaxation time in absence of any polarization effects).

The relaxation phenomenon described herein is also called first-cycle effect, secondary break-in, wait-time effect, memory effect, and hysteresis phenomenon which is in connection with the characteristic changes of the cyclic voltammograms obtained for \rightarrow polymer-modified electrodes [iii–vi].

This phenomenon has been studied by different combined electrochemical techniques such as \rightarrow spectroelectrochemistry, radioactive \rightarrow tracer method, \rightarrow electrochemical quartz crystal microbalance, conductivity etc. by varying the experimental parameters, e.g., film thickness, the composition and concentration of the electrolyte solutions, the wait-time at different waiting potentials, and temperature [iii–x]. Several interpretations have been developed beside the ESCR model. The linear dependence of the anodic peak potential on the logarithm of the time of cathodic electrolysis (wait-time) – when the polymer in its reduced state is an insulator – has been interpreted by using the concept of electric percolation [ix]. Other effects have also been taken into account such as incomplete reduction [vii], slow sorption/desorption of ions and solvent molecules [iii–vi], variation of the equilibrium constants of \rightarrow polarons and \rightarrow bipolarons [viii], dimerization [xi], heterogeneous effects [xii], etc.

Refs.: [i] Otero TF, Grande H, Rodrigues J (1995) *J Electroanal Chem* 394:211; [ii] Otero TF, Boyano I (2003) *J Phys Chem B* 107:6700; [iii] Inzelt G, Day RW, Kinstle JF, Chambers JQC (1983) *J Phys Chem* 87:4592; [iv] Inzelt G (1989) *Electrochim Acta* 34:83; [v] Inzelt G (1994) In: Bard AJ (ed) *Electroanalytical chemistry* vol. 18, Dekker, New York, pp 89–241; [vi] Inzelt G, Pineri M, Schulze JW, Vorotyntsev MA (2000) *Electrochim Acta* 45:2403; [vii] Kalaji M, Nyholm L, Peter LM (1991) *J Electroanal Chem* 313:271; [viii] Odin C, Nechtschein (1991) *Synth Met* 43:2943; [ix] Aoki K (1994) *J Electroanal Chem* 373:67; [x] Rodríguez Presa MJ, Posadas D, Florit MI (2000) *J Electroanal Chem* 482:117; [xi] Vorotyntsev MA, Heinze J (2001) *Electrochim Acta* 46:3309; [xii] Heinze J, Rasche A (2006) *J Solid State Electrochem* 10:148

JH

Electrochemically modulated surface plasmon resonance (EM-SPR) \rightarrow surface plasmon resonance

Electrochemiluminescence — Chemiluminescence is the generation of light during chemical reactions. When the species involved in the reactions are produced electrochemically the phenomenon is called electrochemiluminescence. This includes reactions where generated reagents (e.g., hydrogen peroxide) cause conventional chemiluminescence, for example, with luminol, as well as the more unique electrochemical reactions that generate radical ions that produce an excited state in a high-energy electron transfer reaction (\rightarrow electrogenerated chemiluminescence). The generation of light from a solid semiconductor electrode, e.g., by hole injection during a reduction, is usually classified as \rightarrow electroluminescence.

Ref.: [i] Bard AJ (ed) (2004) *Electrogenerated chemiluminescence*. Marcel Dekker, New York, p 2

RH, AJB

Electrochemistry — Electrochemistry, as the name suggests, is a branch of chemical science that deals with the interrelation of electrical and chemical phenomena [i]. From the very beginning electrochemistry covers two main areas: the conversion of the energy of chemical reactions into electricity (electrochemical power sources) and the transformations of chemical compounds by the passage of an electric current (\rightarrow electrolysis).

Electrochemistry is an interdisciplinary science that is mainly rooted in chemistry and physics; however, also linked to engineering and biochemistry/biology. According to this overlap, a simple definition cannot be given and it depends very much on the point-of-view what will be included.

Electrochemistry is usually understood as part of physical chemistry, but it can be also subdivided according to the involved chemistry:

- fundamental electrochemistry (physical electrochemistry, including theoretical or quantum electrochemistry);
- inorganic and organic electrochemistry;
- bioelectrochemistry;
- technical or industrial electrochemistry.

Another way of subdividing is according to the physical locus of the processes:

- electrochemistry at interfaces (\rightarrow electrodicts, excluding the interface to vacuum);

- electrochemistry of ionic transport processes (diffusion, migration, convection) within phases (\rightarrow *ionics*, [ii]), and structure of electrolyte solutions and salt melts.

E

A very general subdivision is:

- thermodynamics of electrochemistry;
- kinetics of electrochemistry.

Electrochemistry is also frequently subdivided according to the state of its objects:

- solution electrochemistry;
- solid-state electrochemistry;
- \rightarrow *plasma electrochemistry* and gas phase electrochemistry.

The following list of working fields reflects the diversity of basic and applied aspects of electrochemistry:

- analytical electrochemistry (\rightarrow *electroanalytical chemistry*);
- \rightarrow *bioelectrochemistry*;
- environmental electrochemistry [iii];
- electrochemistry of intrinsic \rightarrow *conducting polymers*;
- electrochemistry of glasses [iv];
- \rightarrow *insertion electrochemistry*;
- \rightarrow *ionic liquids* electrochemistry;
- microelectrochemistry, nanoelectrochemistry, and spatial resolved electrochemistry (e.g., probe techniques [v]);
- molten salt electrochemistry (\rightarrow *room temperature molten salts*);
- \rightarrow *photoelectrochemistry* [iii];
- \rightarrow *solid state electrochemistry* (solid electrolytes);
- solution electrochemistry (liquid electrolytes);
- surface electrochemistry;
- technical electrochemistry with numerous sub-topics such as:
 - \rightarrow *batteries* and energy storage [vi];

- \rightarrow *corrosion* and corrosion inhibition;
- electrochemical synthesis and reactors (\rightarrow *electrosynthesis*);
- electronic components (\rightarrow *capacitors*, displays, information storage, rectifiers);
- \rightarrow *fuel cells*;
- \rightarrow *galvanic deposition*;
- theoretical or quantum electrochemistry.

A very specific definition, which reduces to aspects not covered by common physics or chemistry, is:

Electrochemistry is the science of structures and processes at and through the interface between an electronic (“electrode”) and an ionic conductor (“electrolyte”) or between two ionic conductors [vii].

As with other branches of science, it is impossible to give a clear-cut definition of electrochemistry since the branching is something man-made, artificial, which ignores the soft transitions between different parts.

Refs.: [i] Bard AJ, Faulkner LR (2001) *Electrochemical methods*, 2nd edn. Wiley, New York; [ii] Bockris JO'M, Reddy AKN (2001) *Modern electrochemistry*. Plenum, New York; [iii] Bockris JO'M, Khan SUM (1993) *Surface electrochemistry*. Plenum, New York; [iv] Bach H, Baucke F, Krause D (2000) *Electrochemistry of glasses and glass melts, including glass electrodes*. Schott Series, Springer, Berlin; [vv] Gewirth AA, Siegenthaler H (1995) *Nanoscale probes of the solid/liquid interface*. NATO ASI Series 288, Kluwer, Dordrecht; [vi] Osaka T, Datta M (2000) *Energy storage for electronics*. Gordon and Breach Science Publ.; [vii] Schmickler W (1996) *Interfacial electrochemistry*. Oxford University Press, New York

GI, MML, FS

Electrochemistry of photosynthesis — Life on Earth has been supported by the continuous flow of solar energy over billions of years. The power of this flux is extremely high: 5×10^{21} kJ per year of which 3×10^{18} kJ is converted into chemical energy by photosynthesis in plants and microorganisms. The annual consumption of energy by mankind is 4×10^{17} kJ, rising rapidly and doubling every 20 years. The known reserves of fossil fuels are limited to an estimated energy equivalent of 5×10^{19} kJ, so new sources of energy are of fundamental importance. One possibility is solar energy. In water-oxidizing photosynthesis two membrane-integrated protein complexes photosystem II (PS II) and photosystem I (PS I) are operating in series. The \rightarrow *electron transfer* starts in both photosystems vectorially across the membrane. Light energy is harvested by photosynthetic pigment systems in

which the electronic structure of excited-state chlorophyll (magnesium-containing porphyrin) donates an electron to a primary acceptor pheophytin, the first component of an electron transport chain. The electron is fortified with it and the energy of the original photon of light it absorbed. In the process of electron transport, the energy is captured in two ways. The first involves the coupling of a \rightarrow *proton pump* mechanism to the sequential redox reactions in the electron transport chain, so that a proton gradient is established across the thylakoid membrane. The electrochemical energy of the proton gradient is then used to drive ATP synthesis by the ATP synthase enzymes embedded in the membrane. The second energy capture occurs when an acceptor molecule such as NADP^+ is reduced to NADPH, which in turn is used to reduce carbon dioxide in the Calvin cycle. The spectral characteristics of photosystem II indicate that the primary electron donor is chlorophyll P680 with absorption maxima near 680 and 430 nm. Water can be oxidized by an oxygen-evolving center (OEC) composed of several chlorophyll molecules, two molecules of pheophytin, plastoquinol, several plastoquinone molecules, and a manganese-protein complex containing four manganese ions. The oxygen-evolving complex is a highly ordered structure in which a number of polypeptides interact to provide the appropriate environment for cofactors such as manganese, chloride, and calcium, as well as for electron transfer within the complex. Plastoquinone (PQ) acts as a transmembrane carrier of electrons and protons between reaction centers of two photosystems in the case of noncyclic electron transfer. Pheophytin is an intermediate acceptor in photosystem II. Direct formation of P680-pheophytin ion radical pairs was revealed by experiments on magnetic interactions between Pheo- and PQ- reflected in the EPR spectra. Water oxidation to molecular oxygen is a multielectron process that proceeds with surprisingly high quantum efficiency. The water oxidation reaction can proceed upon illumination at 680 nm, a wavelength of light that excludes one-electron mechanisms using hydroxyl and oxygen radicals. For a three-electron reaction an oxidant stronger than the cation-radical P680^+ is needed. A synchronous two by two electron pathway of the reaction is thermodynamically possible if the standard free energy of binding of the two-electron intermediate is about -40 kJ/mol. This value corresponds to the energy of formation for two hydrogen bonds between H_2O_2 and the catalytic center. Membrane-bound P680 enters an excited state upon illumination. In several picoseconds, an electron is first transferred to pheophytin, then to plastoquinone Q_A , and from plastoquinone Q_A

to another polypeptide-bound plastoquinone Q_B in thylakoid membrane resulting in an oxidized pigment and a reduced acceptor. The cation radical P680^+ successively oxidizes four manganese ions, which in turn drives the production of molecular oxygen. A synchronous multielectron process that describes all four oxidizing states of the oxygen-evolving complex was proposed earlier. The transfer of electrons in a 1:1:1:1 series from a manganese cluster to the electron-transport chain is accompanied by the ejection of 1:0:1:2 protons and the evolution of molecular oxygen.

Refs.: [i] Volkov AG (1989) *Bioelectrochem Bioenerg* 21:3; [ii] Volkov AG (2002) *Biocatalysis: Electrochemical mechanisms of respiration and photosynthesis*. In: Volkov AG (ed) *Interfacial catalysis*. Marcel Dekker, New York

AV

Electrochemistry of respiration — The function of the enzymes in the mitochondrial respiratory chain is to transform the energy from the redox reactions into an electrochemical proton gradient across the hydrophobic barrier of a coupling membrane. Cytochrome oxidase (EC 1.9.3.1, PDB 2OCC) is the terminal electron acceptor of the mitochondrial respiratory chain. Its main function is to catalyze the reaction of oxygen reduction to water using electrons from ferrocyclochrome *c*: $4\text{H}^+ + \text{O}_2 + 4\text{e}^- \rightleftharpoons 2\text{H}_2\text{O}$. This reaction is exothermic, and its energy can be used to transport protons across the mitochondrial membrane. The enzyme contains cytochromes *a* and *a*₃, one binuclear copper complex Cu_a , one mononuclear copper site Cu_b and one bound Mg^{2+} per monomer. It has a molecular weight ranging from 180,000–200,000 kDa for the most active form. Cytochrome oxidases can transport a maximum of eight protons across the membrane per oxygen molecule reduction. Four of the protons bind to the reaction complex during the reduction of oxygen to water and up to four other protons are transported across the membrane. The resulting proton gradient is used in ATP synthesis. The first step in oxygen reduction by cytochrome *c* oxidase should be a concerted two-electron process. The reaction implies that the \rightarrow *Gibbs energy* of the first electron transfer from cytochrome oxidase to O_2 is positive. As a result, this route should be abandoned, or the reaction rate should be extremely low. The Gibbs free energy of O_2 binding in the catalytic site of cytochrome oxidase is -21 kJ mol⁻¹, cytochrome *c* redox potential is 0.25 V. The Gibbs free energy of the first electron donation to oxygen at pH 7 is $+33$ kJ mol⁻¹. The Gibbs free energy of the reaction $\text{O}_2 + \text{e}^- \rightarrow \text{O}_2^-$ in catalytic site should be equal to $+79$ kJ mol⁻¹. Activation en-

ergy for O_2 reduction by fully reduced cytochrome oxidase is equal to 16 kJ mol^{-1} . Since the Gibbs free energy of the endothermic reaction is five times the measured activation energy for O_2 reduction by cytochrome oxidase, the single-electron mechanisms 1:1:1:1, 1:2:1, 1:1:2, and 1:3 at room temperature are unlikely. The fact that the first electron addition to O_2 is endothermic accounts for the relative chemical inertness of oxygen in nature and it permits the existence of life on Earth. A possible mechanism of oxygen reduction by cytochrome *c* oxidase is outlined in a scheme:

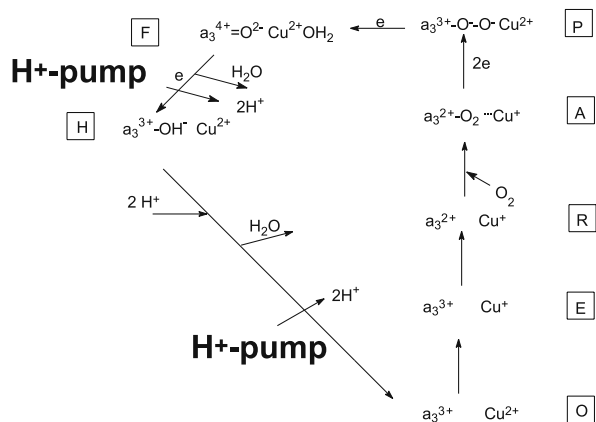

Electrochemistry of respiration — Figure

Water molecules released in the course of oxygen reduction are transferred from the hydrophobic catalytic site to the aqueous phase. Energy liberated in the exothermic reaction is sufficient for transporting 8 H^+ ions across the membrane. Four of the H^+ ions couple with O_2 to form two H_2O molecules. The remaining H^+ ions can be transported across the hydrophobic zone of the membrane and used for ATP synthesis in ATP-synthase complex. As follows from thermodynamics, the energy needed for the function of the \rightarrow proton pump is liberated only at the last steps of water formation on the addition of third and fourth electrons independently of the reaction route. The functioning of protons pump after formation of ferryl intermediate is possible only if the difference between Gibbs energy of ferryl and peroxy intermediates binding is less than -35 kJ/mole . The binding energy of the ferryl intermediate is negative. This energy supports the proton pump function not only during the addition of fourth electron, but also after the formation of the 3-electron oxygen intermediate. The stoichiometry of proton pumping by cytochrome oxidase is 0:2:2.

Refs.: [i] Volkov AG (2002) *Biocatalysis: Electrochemical mechanisms of respiration and photosynthesis*. In: Volkov AG (ed) *Interfacial catalysis*. Marcel Dekker, New York; [ii] Kharkats YuI, Volkov AG (1998) *Anal Sci* 14:29; [iii] Volkov AG, Brown CL (2006) *Nanodevices in nature*. In: Kumar CSSR (ed) *Nanodevices for life sciences*. Wiley-VCH, Weinheim, pp 440–463

AV

Electrochromatography \rightarrow *capillary electrochromatography (CEC)*

Electrochromism, electrochromic devices — Electrochromism is the phenomenon whereby a reversible color change takes place upon \rightarrow reduction or \rightarrow oxidation, on passage of electrical current after the application of an appropriate \rightarrow electrode potential [i, ii]. Where the switching of redox states generates new or different visible region bands, the material is said to be electrochromic. Color changes in an object give visual signals that can be used to convey useful information to an observer. Furthermore, by selective absorption or transmission of light by a material, the light energy impinging upon an observer can be modulated.

Many chemical species can be switched between \rightarrow redox states that have distinct electronic absorption spectra [i–iv]. Such spectra arise from either a moderate-energy internal electronic excitation or an intervalence-optical charge transfer where the chemical species has two centers of differing valence or oxidation state. While materials are considered to be electrochromic when marked visible color changes are shown under illumination, recent interest in electrochromic devices for multispectral energy modulation by reflectance and absorbance has extended the definition. Chemical species are now being studied for modulation of radiation in the near infra-red (NIR), thermal infra-red, and microwave regions, and “color” can mean response of detectors to these electromagnetic regions, not just the human eye [v].

Electrochromic materials are of three basic types [i]. In a given \rightarrow electrolyte solution, “type I” materials are soluble in both the reduced and oxidized (redox) states, an example being 1,1'-di-methyl-4,4'-bipyridylum (“methyl viologen”), which, on reduction, switches from the colorless di-cation to the blue radical cation. “Type II” materials are soluble in one redox state, but form a solid film on the surface of an electrode following electron transfer. An example here is 1,1'-di-heptyl-4,4'-bipyridylum (“heptyl viologen”). In “type III” materials, such as \rightarrow tungsten oxide, \rightarrow Prussian blue, and electroactive conjugated polymers, both

or all redox states are solids, and such systems are generally studied as thin films on electrode surfaces. For types II and III, once the redox state has been switched, no further charge injection is needed to retain the new electrochromic state and such systems are said to have “optical memory”. For type I electrochromic materials, → *diffusion* of the soluble electrochemically generated product material away from the electrode occurs and it is necessary to keep current flowing until the whole solution has been electrolyzed. Where more than two redox states are electrochemically accessible in a given electrolyte solution, the electrochromic material may exhibit several colors and be termed polyelectrochromic, a frequent property of thin films of electroactive conjugated polymers.

Commercial applications of electrochromic materials in devices include anti-glare car rear-view mirrors [vi, vii], electrochromic strips as battery state-of-charge indicators, and electrochromic sunglasses. Proposed applications include “smart windows” (based on modulation of either the transmitted or reflected solar radiation) for use in cars and in buildings [vi], reusable price labels, protective eyewear, controllable aircraft canopies, glare-reduction systems for offices, devices for frozen-food monitoring, camouflage materials, spacecraft thermal control, and controllable light-reflective or light-transmissive display devices for optical information and storage.

There is a vast number of chemical species that show electrochromic properties [i], including both metal coordination complexes in solution and as polymer films [iv], metal oxide films (especially tungsten oxide) [i, ii], viologens (4,4'-bipyridylum salts; in solution and as polymer films) [viii], and electroactive conjugated polymers [iii], such as → *polypyrrole*, → *polythiophene*, and → *polyaniline*, as thin films. Other classes of electrochromic material include Y, La, and Y/La alloys [vi], which switch from a reflecting-mirror metallic state to a transparent semiconducting phase on hydride formation, and metal deposition/stripping systems [i]. See → *electrodeposition*. It is important, however, to realize that while many types of chemical species exhibit electrochromism, only those with favorable electrochromic performance parameters [i] are potentially useful in commercial applications. Thus most applications require electrochromic materials with high contrast ratio, coloration efficiency, cycle life, and write-erase efficiency. Some performance parameters are application dependent; displays need low response times, whereas “smart windows” can tolerate response times of up to several minutes.

Refs.: [i] Monk PMS, Mortimer RJ, Rosseinsky DR (2007) *Electrochromism and electrochromic devices*. Cambridge University Press, Cambridge; [ii] Granqvist CG (1995) *Handbook of inorganic electrochromic materials*. Elsevier, Amsterdam; [iii] Mortimer RJ, Dyer AL, Reynolds JR (2006) *Displays* 27:2; [iv] Mortimer RJ, Rowley NM (2004) *Metal complexes as dyes for optical data storage and electrochromic materials*. In: McCleverty JA, Meyer TJ, Ward MD (eds) *Comprehensive coordination chemistry II: from biology to nanotechnology* 9.2. Elsevier, Oxford, pp 581–619; [v] Rauh RD (1999) *Electrochim Acta* 44:3165; [vi] Mortimer RJ, Rosseinsky DR (2001) *Adv Mater* 13:783; [vii] Green M (1996) *Chem Ind* 641; [viii] Monk PMS (1998) *The viologens: Physicochemical properties, synthesis and applications of the salts of 4,4'-bipyridine*. Wiley, Chichester

RJM

Electrocoating — Electrocoating is the process of forming a functional or decorative coating on a substrate by applying an electric current. A typical application is cathodic dip painting (→ *cataphoresis*) of automotive parts. In that process the electrolysis of water, $4\text{H}_2\text{O} + 4\text{e}^- \rightarrow 2\text{H}_2 + 4\text{OH}^-$, leads to an increase of the pH value in front of the cathode which in turn causes the coagulation and deposition of a dispersed phase (e.g., paint). See also → *galvanism*, → *galvanize*.

Ref.: [i] Vatisias N (1998) *Ind Eng Chem Res* 37:944

AB

Electroconvection

1. is the macroscopic motion of a solution resulting from the effect of gravity on non-equilibrium density gradients caused by potential differences (→ *electric field*). The density changes are generated by → *electrostriction*. In practice, electroconvection is largely confined to solutions near charged interfaces, because that is where the electric fields are largest.
2. (also called electrohydrodynamic): This is an → *electrokinetic effect*. When an AC field is applied across nematic and smectic liquid crystals [i], or across a colloidal suspension [ii], convection is caused and specific convection patterns are induced. The phenomenon belongs to the pattern formation due to the nonlinear response of dissipative media to external fields. Thus electroconvection bears some similarity to Bénard [iii] and Bénard–Marangoni [iv] convection caused by a temperature gradient. (See also → *Marangoni streaming*). See also → *electrorheological fluid* for liquids with a high content of dispersed particles. See also → *Quincke rotation*.

Refs.: [i] Blinov LM (1998) *Behaviour of liquid crystals in electric and magnetic fields*. In: Demus D, Goodby J, Gray GW, Spiess HW, Vill V (eds) *Handbook of liquid crystals*, vol. 1. Wiley-VCH, Weinheim, pp 477; [ii] Han Y, Grier DG (2005) *J Chem Phys* 122:164701 (DOI: 10.1063/1.1884599); [iii] Bénard H (1900) *Rev Gén Sci Pure Appl* 11:126; [iv] Tokaruk WA, Molteno TCA, Morris SW (2000) *Phys Rev Lett* 84:3590

SF, FS

Electrocrystallization — A term first coined by Fischer [i] to describe a crystallization process in which the electrode potential provides the driving force, either directly in the form of a \rightarrow *crystallization overpotential*, or indirectly in the form of a \rightarrow *supersaturation*. (A solution is said to be “supersaturated” if it contains a concentration of a dissolved substance that is greater than the equilibrium concentration.)

See also \rightarrow *nucleation and growth kinetics*, \rightarrow *nucleation overpotential*, \rightarrow *electrodeposition*, \rightarrow *Stranski*, \rightarrow *Kaishev*.

Ref.: [i] Fischer HJ (1954) *Elektrolytische Abscheidung und Elektrokristallisation von Metallen*. Springer, Berlin

SF

Electrode — There are currently two usages for the term electrode, namely either (i) the electron conductor connected to the external leads or (ii) the \rightarrow *half-cell* between one electron conductor and at least one ionic conductor. The latter version has usually been favored in electrochemistry [i]. The half cell, i.e., the electrode may have a rather complicated structure. In the simplest case a pure solid metal is in contact with an electrolyte solution containing its own ions. However, the electronic conductor may be also an alloy (e.g., an amalgam), carbon (e.g., graphite, glassy carbon) boron-doped diamond, a semiconductor (e.g., a metal oxide, metal salt, doped silicon, germanium alloys), or metal oxides (e.g., iridium dioxide, titanium covered with ruthenium dioxide). The most important electrode materials are listed under the entry \rightarrow *electrode materials*. It should also be mentioned that even when a pure metal is immersed into an electrolyte solution, its surface may be covered, e.g., with an oxide layer. Typical examples are magnesium or aluminum, however, even the surface of platinum is covered with oxides when it is stored in air or at higher positive potentials. Beside the spontaneously formed surface layers, the surface of metals or other substances is often modified on purpose to obtain electrodes for special functions. When a metal surface is covered by an electrochemically active polymer layer we speak of \rightarrow *polymer-modified* (or polymer film) electrodes which become an important class of electrodes.

A satisfactory definition which includes the factors and problems mentioned above, may be as follows. **The electrode consists of two or more electrically conducting phases switched in series between which charge carriers (ions or electrons) can be exchanged, one of the terminal phases being an electron conductor and the other an electrolyte.** The electrode can be schematically denoted by these two terminal phases, e.g., $\text{Cu(s)}|\text{CuSO}_4(\text{aq})$, disregarding all other phases that may be interposed. However, in certain cases more phases are displayed, e.g., $\text{Ag(s)}|\text{AgCl(s)}|\text{KCl(aq)}$ or $\text{Pt(s)}|\text{polyaniline(s)}|\text{H}_2\text{SO}_4(\text{aq})$ since the consideration of those phases are essential regarding the equilibria and the thermodynamic description. The electrodes can be classified in several ways [ii–vi]. The electrode on which reduction (transfer of electrons from the metal to the dissolved species) occurs is called \rightarrow *cathode*, that on which oxidation takes place is called \rightarrow *anode*. The positive electrode is the cathode in a \rightarrow *galvanic cell* and the anode is in an \rightarrow *electrolytic cell*. In a galvanic cell the negative electrode is the anode, while in an electrolytic cell it is the cathode. According to the nature of species participating in electrochemical equilibria and the realization of the equilibria we may speak of \rightarrow *electrodes of the first kind*, \rightarrow *electrodes of the second kind*, \rightarrow *electrodes of the third kind*, \rightarrow *redox electrodes*, and \rightarrow *membrane electrodes*. When more than one electrode reaction takes place simultaneously at the interface, the electrode is a mixed electrode. Another important distinction is based on whether charged species cross the interface or not. In the former case when the \rightarrow *charge transfer* is infinitely fast the electrode is called \rightarrow *ideally non-polarizable electrode*. When no charge transfer occurs through the interface and the current (charge) that can be measured merely contributes to the establishment of the \rightarrow *electrical double layer*, the term is \rightarrow *ideally polarizable electrode*. There are also names which express the function of the electrode and refer to the whole construction including mechanical parts of the electrode, e.g., \rightarrow *dropping mercury* or \rightarrow *hanging mercury drop electrodes*, \rightarrow *rotating disk electrode*, combination \rightarrow *glass electrode*, \rightarrow *optically transparent electrodes*, photoelectrodes (\rightarrow *photoelectrochemistry*). Electrodes with different properties can be constructed by using the same element or compound for the solid phase, however, in various crystal forms, morphology, surface structure, with or without additives. For instance, carbon electrodes are made of various materials, such as graphite of spectral purity, graphite powder with liquid or solid binders, glassy carbon, carbon fibers, highly oriented pyrolytic graphite, paraffin impregnate graphite (PIGE), or

diamond. Platinum can be polycrystalline or in the form of different single crystals (well-defined electrodes). The \rightarrow *electrode geometry* also plays an important role. Electrodes can be classified according to their form such as: inlaid disk, sphere, cylinder, sheet, net, spiral wire, sponge, inlaid ring, inlaid plate, ring-disk, etc. The electrode size is also an important factor, and consequently macroelectrodes, \rightarrow *microelectrodes*, and \rightarrow *ultramicroelectrodes* are distinguished. The functional grouping is as follows: The electrode which is under study is called \rightarrow *working electrode* in \rightarrow *voltammetry* or \rightarrow *indicator electrode* in \rightarrow *potentiometry*. The electrode, the potential of which is practically constant and used to compare electrode potentials, i.e., to define the value of the potential of the electrode on the scale based on \rightarrow *standard hydrogen electrode*, is called a \rightarrow *reference electrode*. The electrode that serves to maintain the current in the circuit formed with the working electrode in voltammetric experiments in three-compartment cells is the \rightarrow *auxiliary (or counter) electrode*.

Refs.: [i] Cohen ER, Cvitas T, Frey JG, et al. (eds) (2007) *IUPAC quantities, units and symbols in physical chemistry*, 3rd edn. RSCPublishing, Cambridge, p 73; [ii] Komorsky-Lovrić Š (2002) *Working electrodes*. In: Scholz F (ed) *Electroanalytical methods*. Springer, Berlin, pp 287–290; [iii] Inzelt G (2002) *Kinetics of electrochemical reactions*. In: Scholz F (ed) *Electroanalytical methods*. Springer, Berlin, pp 245–278; [iv] Petrii OA, Tsirlina GA (2002) *Electrode potentials*. In: Bard AJ, Stratman M, Gileadi E, Urbakh M (eds) *Thermodynamics and electrified interfaces*. Encyclopedia of electrochemistry, vol. 1. Wiley-VCH, Weinheim, pp 1–23; [v] Parsons R (1974) *Pure Appl Chem* 37:503; [vi] Trasatti S, Parsons R (1986) *Pure Appl Chem* 58:437

GI

Electrode of the first kind — Originally (e.g., by \rightarrow *Nernst*) only electrodes consisting of a metal (M) in contact with an electrolyte solution containing M^{z+} ions were considered. In several books this traditional definition can still be found, e.g., [i–iv], however, in the literature wider interpretations can also be found. Recently, the electrodes of the first kind have been defined as follows [v]: Electrodes of the first kind contain electronic conductors as the reduced forms, and ions (particularly, complex ions) as the oxidized forms. The equilibrium can be established with respect to cations and anions; in the absence of ligands, the cations are more typical. This group can be supplemented also by amalgam electrodes (or other liquid electrodes) and electrodes fabricated from nonstoichiometric solids capable of changing their composition reversibly (intercalation compounds (\rightarrow *insertion electrodes*) based on carbons, oxides, sulfides, and multicomponent salts, particularly, Li-intercalating electrodes of \rightarrow *batteries*).

Sometimes gas electrodes (especially the \rightarrow *hydrogen electrode*) have also been listed among electrodes of the first kind [vi]. In this case the following definition is given: electrodes are called electrodes of the first kind when the equilibrium is established between an element (e.g., beside a metal, H_2 , O_2 , Cl_2) or more generally a neutral species and its ions in the solution phase. In several books gas electrodes form a separate category [iii], and they can also be considered as \rightarrow *redox electrodes* [vii]. There is a similar problem with the definition [v] described above since complex electrodes, i.e., when a metal is immersed in an electrolyte containing ligands, may be arranged among the \rightarrow *electrodes of the second kind*.

The terminology of electrode of the first, second, and third etc. kind (type) is somewhat archaic [ii] and the grouping to a certain extent is artificial [iv]. It might be the reason that most books that appeared in the last decades do not mention this category of electrodes.

Refs.: [i] Kahlert H (2002) *Potentiometry*. In: Scholz F (ed) *Electroanalytical methods*. Springer, Berlin, pp 227–228; [ii] Oldham KB, Myland JC (1994) *Fundamentals of electrochemical science*. Academic Press, San Diego, p 135; [iii] Damaskin BB, Petrii OA (1978) *Fundamentals of theoretical electrochemistry*. (In Russian), Vysshaya Shkola, Moscow, p 118; [iv] Brett CMA, Oliveira Brett AM (1993) *Electrochemistry*. Oxford University Press, p 21; [v] Petrii OA, Tsirlina GA (2002) *Electrode potentials*. In: Bard AJ, Stratman M, Gileadi E, Urbakh M (eds) *Thermodynamics and electrified interfaces*. Encyclopedia of electrochemistry, vol. 1. Wiley-VCH, Weinheim, pp 1–23; [vi] Erdey-Grúz T (1972) *Kinetics of electrode processes*, p 149; [vii] Hamann CH, Hammett A, Vielstich W (1998) *Electrochemistry*. Wiley-VCH, Weinheim, p 86

GI

Electrode of the second kind — Electrodes of the second kind [i–ii] contain a metal, a poorly soluble compound of this metal (which is usually a salt but it may be oxide or hydroxide as well), and an electrolyte which can establish a solubility equilibrium with the precipitate. Typical examples are $Ag(s)|AgCl(s)|KCl(aq)$, $Hg(l)|Hg_2Cl_2(s)|KCl(aq)$, $Hg(l)|HgO(s)|NaOH(aq)$, $Hg(l)|HgSO_4(s)|H_2SO_4(aq)$. The solubility equilibrium, e.g., for the silver chloride electrode, is as follows

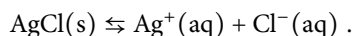

The electrode reaction is

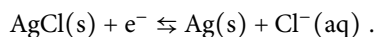

The electrode potential depends on the activity of anions:

$$E = E_{Ag/AgCl}^{\ominus} - \frac{RT}{F} \ln a_{Cl^-} .$$

Because of the fast establishment of the solubility equilibrium, the electrode potentials remain practically constant even if a – not too high – current flows, therefore, electrodes of the second order are the most frequently used → *reference electrodes*.

Refs.: [i] Kahlert H (2002) *Potentiometry*. In: Scholz F (ed) *Electroanalytical methods*. Springer, Berlin, p 229; [ii] Petrii OA, Tsirlina GA (2002) *Electrode potentials*. In: Bard AJ, Stratman M, Gileadi E, Urbakh M (eds) *Thermodynamics and electrified interfaces*. *Encyclopedia of electrochemistry*, vol. 1. Wiley-VCH, Weinheim, p 10; [iii] Kahlert H (2002) *Reference electrodes*. In: Scholz F (ed) *Electroanalytical methods*. Springer, Berlin, pp 261–277

Electrode of the third kind — Electrodes of the third kind contain a metal and two salts with a common anion. For instance, $\text{Zn(s)}|\text{ZnC}_2\text{O}_4\text{(s)}$, $\text{CaC}_2\text{O}_4\text{(s)}|\text{Ca(NO}_3)_2\text{(aq)}$. In these electrodes simultaneous equilibria with respect to anions and cations exist. The electrode reaction is

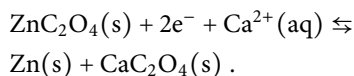

There are two solubility equilibria:

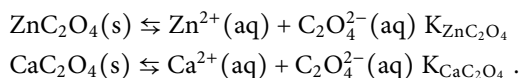

Therefore, the electrode potential can be given as follows:

$$E = E^\ominus + \frac{RT}{2F} \ln a_{\text{Ca}^{2+}} ,$$

where E^\ominus can be expressed as

$$E = E_{\text{Zn}^{2+}/\text{Zn}}^\ominus + \frac{RT}{2F} \ln \frac{K_{\text{ZnC}_2\text{O}_4}}{K_{\text{CaC}_2\text{O}_4}} .$$

These electrodes are seldom used in practice, mostly for the determination of the activity of the metal ion ($a_{\text{Ca}^{2+}}$ in our example) and the solubility products.

Refs.: [i] Petrii OA, Tsirlina GA (2002) *Electrode potentials*. In: Bard AJ, Stratman M, Gileadi E, Urbakh M (eds) *Thermodynamics and electrified interfaces*. *Encyclopedia of electrochemistry*, vol. 1. Wiley-VCH, Weinheim, pp 10–11

Ideally polarizable electrode — Upon transferring electric charge to → *electrodes* (to the → *interfaces* between the electronically and ionically conducting phases, respectively) by means of → *charge-carrier ions*, various changes occur. The charge carriers (ions,

electrons) reaching the surface of an indifferent electrode (i.e., the surface of the metal which does not release nor neutralize ions) cannot undergo → *discharge* to form components of neutral particles. Under such conditions, the charge carriers enter the → *double layer* → *capacitor* located at the phase interface and change the amount of charge on it, and the → *potential difference* across its plates. The change of the potential difference is reflected by the polarization of the electrode. Systems which behave in this manner are ideally polarizable electrodes.

There is no thermodynamic equilibrium between the ideally polarizable electrode (more exactly the metal phase) and the solution phase because there is no common component capable of changing its charge and being transferred between the phases, conditions necessary for equilibrium. The state of an ideally polarizable electrode is well defined only if an external source is used to maintain a constant polarization potential, i.e., the double-layer capacitor charged with a definite charge. The polarization potential is an independent parameter of the system.

Ideal polarizability can only be realized, even approximately, in a limited potential range.

Noble metal electrodes (e.g., Pt between the hydrogen and oxygen adsorption potential regions (→ *chemisorption*) or Au until oxygen adsorption) or the → *mercury electrode* in a solution not containing mercury ions, at such negative potential where the $\text{Hg} \rightarrow \text{Hg}^{2+} + 2\text{e}^-$ reaction is negligibly slow, due to the high hydrogen overpotential, serve as examples of ideal polarizability.

For ideally polarizable electrodes – since as a whole, the double layer is electrically neutral – the absolute value of the → *surface charge* on the metal (σ^M) should be equal to the opposite charge accumulated at the solution phase near the metal (σ^S), i.e., $\sigma^M = -\sigma^S$. σ is called free surface charge density and for the ideally polarizable electrode it is equal to the surface charge density (Q), i.e., $\sigma = Q$. σ values can be determined by using the → *Lippmann equation* from the results of electrocapillary measurements. When $\sigma^M = \sigma^S = 0$, i.e., at the → *potential of zero charge* (pzc , $E_\sigma = E_Q = 0$) the → *Galvani potential difference* between the two phases is due to the orientation of dipoles (e.g., water molecules) [i, v].

Refs.: [i] Trasatti S, Parsons R (1986) *Pure Appl Chem* 58:437; [ii] Erdey-Grúz T (1972) *Kinetics of electrode processes*. Akadémiai Kiadó, Budapest, pp 31–32; [iii] Bard AJ, Faulkner LR (2001) *Electrochemical methods*, 2nd edn. Wiley, New York, pp 11–18; [iv] Komorsky-Lovrić Š (2002) *Working electrodes*. In: Scholz F (ed) *Electroanalytical methods*. Springer, Berlin, pp 246; [v] Parsons R (1974) *Pure Appl Chem* 37:503

Ideally nonpolarizable electrode — Ideally nonpolarizable electrodes (ideally unpolarizable → *inter-faces*) are those for which the exchange of common charged components between phases proceeds unhindered [i–iii]. This is the case when the → *exchange current density* (j_0) and the → *standard rate constant* of the → *electrode reaction* is high, i.e., the → *activation energy* is small. The potential is practically unaffected by small → *current densities* (j) until $j_0 \gg j$. At high current densities → *diffusion* (concentration) → *polarization* becomes operative. Such electrodes show electrochemical → *reversibility* and nernstian behavior (→ *nernstian electrode*). A thermodynamic → *equilibrium exists*, and the → *Nernst equation* can be applied regardless of the current flow. The surface equilibrium is a consequence of the very fast → *charge transfer kinetics*. → *Polarizability* and nonpolarizability is not an absolute property of an electrode (interface) but depends on a number of conditions, e.g., on the time scale of the experiment.

Refs.: [i] Trasatti S, Parsons R (1986) *Pure Appl Chem* 58:437; [ii] Erdey-Grúz T (1972) *Kinetics of electrode processes*. Akadémiai Kiadó, Budapest, pp 31–32; [iii] Inzelt G (2002) *Kinetics of electrochemical reactions*. In: Scholz F (ed) *Electroanalytical methods*. Springer, Berlin, pp 29–49

Electrocatalytic electrode — An electrode at which an electrochemical process is subject to catalysis, i.e., in most cases its rate is increased [i, ii]. Strictly speaking the electron-conducting material (or hole-

conducting in case of some semiconductors) commonly named an electrode is only a source (in case of reductions) or sink (in case of oxidations) for electrons transferred in the electrochemical reaction. Based on numerous observations of greatly varied rates of electrode reactions depending on the metal employed (e.g., in case of the hydrogen evolution reaction almost ten orders of magnitude) the interaction between the reacting species and the metal (or more generally the electrode) must play a central role in determining the rate of the reaction. Because the metal itself remains unchanged the phenomenon fits the classical description of catalysis. An electrode showing a considerably higher rate of electrode reaction is thus termed electrocatalytic electrode. The correlation between the enthalpy of the metal–hydrogen bond as displayed below implies that an adsorptive interaction plays a central role in determining the activity of an electrocatalytic electrode.

Attempts to support models of the catalytic activity and the operative mechanism with results of theoretical considerations have been reported for the oxygen reduction [iii] and hydrogen oxidation [iv]. Electrocatalytic electrodes are indispensable parts of → *fuel cells* [v]. A great variety of electrocatalytic electrodes has been developed for analytical applications [vi]. See also → *electrocatalysis*, → *catalytic current*, → *catalytic hydrogen evolution*, → *catalymetry*.

Refs.: [i] Holze R (1989) *Leitfaden der Elektrochemie*. Teubner, Stuttgart; [i] Bockris JO'M, Khan SUM (1993) *Surface electrochemistry*. Plenum

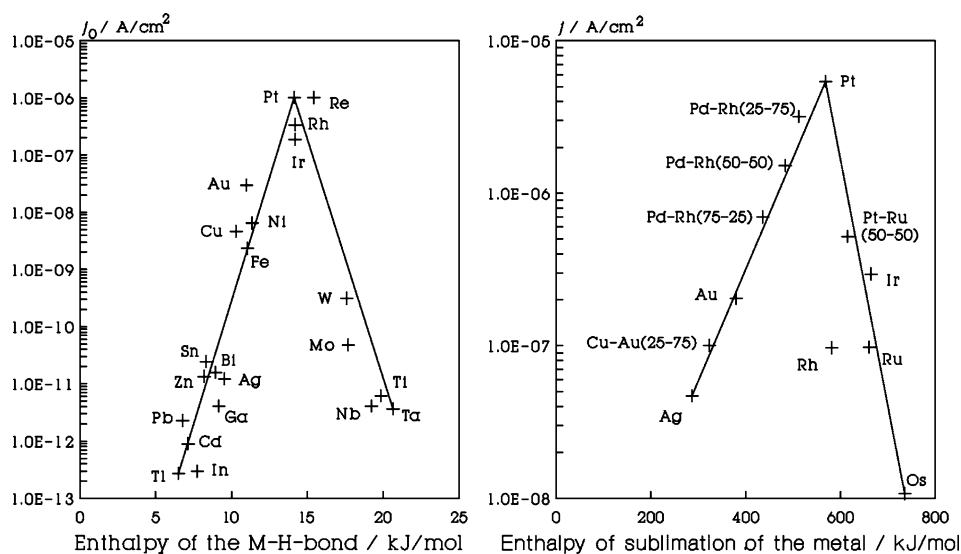

Electrode — Electrocatalytic electrode — **Figure.** Plots of the exchange current density of the hydrogen electrode reaction (*left*) as a function of the enthalpy of the metal–hydrogen bond and the current density of the electrochemical oxidation of ethylene as a function of the enthalpy of sublimation of various metals and alloys (*right*). These displays are also called Volcano plots

Press, New York; [iii] Shi Z, Zhang J, Liu Z-S, Wang H, Wilkinson DP (2006) *Electrochim Acta* 51:1905; [iv] Norskov JK, Bligaard T, Logadottir A, Kitchin JR, Chen JG, Pandelov S, Stimming U (2005) *J Electrochem Soc* 152:J23; [v] Vielstich W, Lamm A, Gasteiger HA (2003) *Handbook of fuel cells: Fundamentals, technology, applications*. Wiley, Chichester; [vi] Drummond TG, Hill MG, Barton JK (2003) *Nature Biotechnol* 21:1192; [vii] Kutner W, Wang J, L'Her M, Buck RP (1998) *Pure Appl Chem* 70:1301; [viii] de Mattos IL, Gorton L (2001) *Quim Nova* 24:200

E

Electrode geometry — Electrode geometry determines how concentration profiles evolve with distance and time according to Fick's second law (see → *Fick's laws*) and thus impacts the current flowing at the electrode surface in an electrochemical experiment through Fick's first law and → *Faraday's law*. There are six broad categories of electrode geometries. These include linear, spherical/hemispherical, conical, cylindrical, inlaid, and arrays. The linear geometry is best represented by a shielded disk electrode, where an inlaid disk (Fig. 1a) is surrounded by walls so that diffusion to and from the electrode is constrained to occur linearly in the x direction. Fick's second law takes the form

$$\frac{\partial C_O(x, t)}{\partial t} = D_O \left(\frac{\partial^2 C_O(x, t)}{\partial x^2} \right) \quad \text{linear geometry,} \quad (1)$$

where C_O and D_O are the concentration and diffusion coefficient, respectively, of oxidized species O at time t and distance x from the electrode surface. For a spherical electrode, as in the case of a hanging mercury drop electrode or a hemispherical mercury drop grown on an inlaid disk electrode (Fig. 1b), Fick's second law is writ-

ten as

$$\frac{\partial C_O(r, t)}{\partial t} = D_O \left(\frac{\partial^2 C_O(r, t)}{\partial r^2} + \frac{2}{r} \frac{\partial C_O(r, t)}{\partial r} \right) \quad \text{spherical geometry,} \quad (2)$$

where spherical diffusion takes place through an increasing area as the radial coordinate r , measured from the center of the spherical electrode, increases. Diffusion to the conical electrode shown in Fig. 1c is often approximated by a hemisphere for small apex (h)/radius (a) ratios. A cylindrical or axial geometry is represented by a wire electrode, and Fick's second law is

$$\frac{\partial C_O(r, t)}{\partial t} = D_O \left(\frac{\partial^2 C_O(r, t)}{\partial r^2} + \frac{1}{r} \frac{\partial C_O(r, t)}{\partial r} \right) \quad \text{cylindrical geometry.} \quad (3)$$

Examples of inlaid geometries are shown as (a, d, e) in Fig. 1. For an inlaid disk electrode (Fig. 1a), Fick's second law is written as

$$\frac{\partial C_O(r, t)}{\partial t} = D_O \left(\frac{\partial^2 C_O(r, t)}{\partial r^2} + \frac{1}{r} \frac{\partial C_O(r, t)}{\partial r} + \frac{\partial^2 C_O(z, t)}{\partial z^2} \right) \quad \text{inlaid disk,} \quad (4)$$

where r is the radial distance measured from the center of the disk and z is the distance normal to the disk. Thus in an inlaid disk electrode of large radius, diffusion occurs predominantly linearly in the z direction to the center of the disk with a small radial diffusion contribution from the edges of the disk known as the edge effect. In

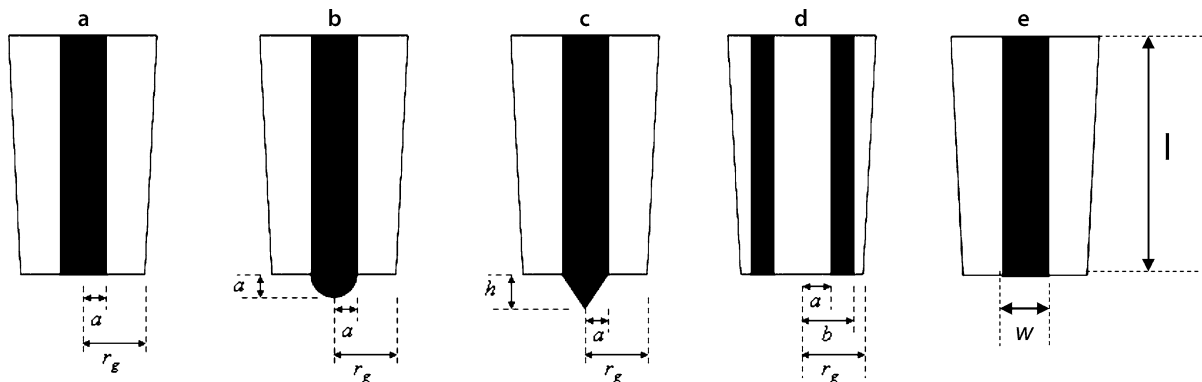

Electrode geometry — **Figure 1.** Electrode geometries. **a** Inlaid disk; **b** hemisphere; **c** conical; **d** ring; **e** band. a refers to the radius of the electrode geometries, h is the height of the conical electrode, w and l are the width and length of a band electrode, and r_g represents the radius of the insulating sheath

inlaid disk ultramicroelectrodes (UMEs), where the diameter is on the order of $25\ \mu\text{m}$ or smaller, the diffusion is predominantly radial to the edges leading to a steady state current that is typical of inlaid disk UMEs. Under steady-state conditions, the left-hand side of the equation is zero; this is also true for spherical, hemispherical, ring, and conical geometries which reach a steady state but not for cylindrical or band geometries which do not reach a steady state. An inlaid band geometry is shown as Fig. 1e where Fick's second law takes the form

$$\frac{\partial C_O(r, t)}{\partial t} = D_O \left(\frac{\partial^2 C_O(x, t)}{\partial x^2} + \frac{\partial^2 C_O(z, t)}{\partial z^2} \right)$$

band electrode,

where x is the distance in the plane of the band and z is the distance normal to the band surface. For wide bands, diffusion to the length of the two edges represent edge effects that make a small contribution to the total current. At a narrow band UME, the edge effects dominate along the length l and a quasi-steady-state current results. The inlaid circular ring electrode (Fig. 1d) is similar to the inlaid disk and inlaid band electrodes in that edge effects can play a major or minor role depending on the ratio of the inner radius (a) to outer radius (b).

Each of the electrode geometries shown in Fig. 1 can be arranged in groups to form array electrodes, examples of which are shown in Fig. 2. The behavior of array electrodes depends on the ratio of the diameter of the individual electrode features to the spacing between electrode features as demonstrated in Fig. 3. Arrays may be made using lithographic procedures or electrochemical or electroless template deposition methods.

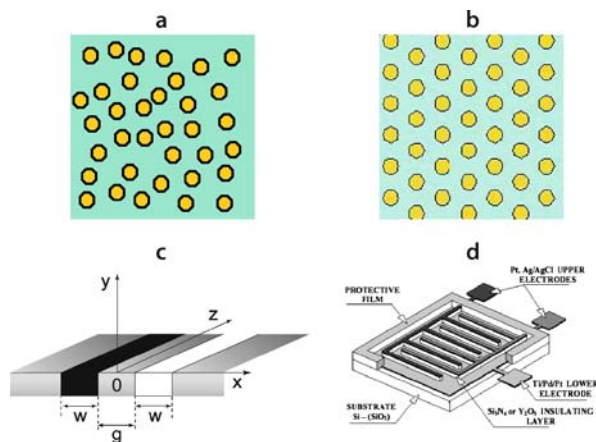

Electrode geometry — Figure 2. Array geometries. **a** Random array of inlaid disk electrodes; **b** ordered array of inlaid disk electrodes; **c** double band array; **d** interdigitated array

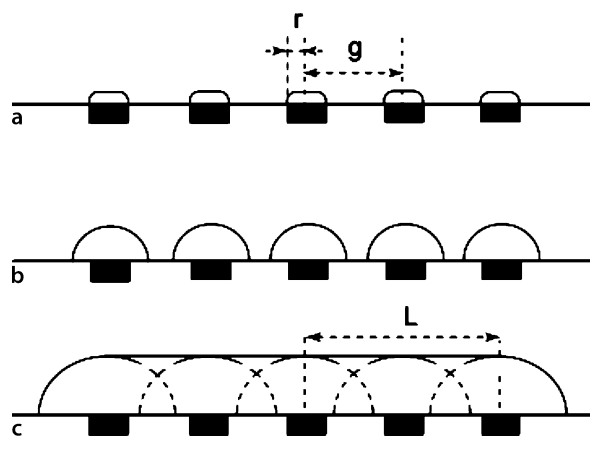

Electrode geometry — Figure 3. Concentration profiles at an array of inlaid disks at different time in response to an electrochemical perturbation. **a** Semi-infinite planar diffusion at short times; **b** hemispherical diffusion at intermediate times; **c** semi-infinite linear diffusion due to overlap of concentration profiles at long times

The inlaid disk and inlaid ring electrode can be combined to make an inlaid electrode in which the disk forms the interior which is surrounded by the ring. This is called a ring-disk electrode and when the entire assembly is rotated about its vertical axis it is referred to as a rotating ring-disk electrode (RRDE). Figure 4 illustrates a rotating disk electrode (RDE).

Refs.: [i] Bard AJ, Faulkner LR (2001) *Electrochemical methods*. 2nd edn. Wiley, New York, chapters 5, 9; [ii] Zoski CG (ed) (2007) *Handbook of electrochemistry*. Elsevier, Amsterdam, chapters 6, 10, 11

CGZ

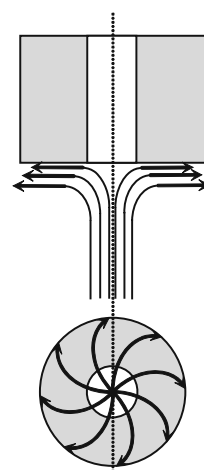

Electrode geometry — Figure 4. Rotating disk electrode (RDE). The RDE rotates around a central axis. The solvent is pulled up vertically to the disk surface and then flung outward from the center in a radial direction

Electrode kinetics → *electrode*, → *kinetics*, → *Butler–Volmer equation*, → *charge transfer kinetics*, → *Marcus theory*

Electrode materials — The electronic conductor of an → *electrode* can be made of a metallic or a semiconducting material that functions as a source or sink of electrons. Examples of such materials follow.

Bimetallic electrodes — This term is used in two different senses: (a) Nowadays, it usually means electrodes with two different metals on their surface, e.g., platinum and ruthenium (→ *electrode materials*, and subentry → *platinum–ruthenium*), or any other pair of metals. The two different metals are used to modify the electrocatalytic properties of electrodes (→ *electrocatalysis*). (b) In the past, a pair of two different metal electrodes used in → *potentiometric titrations* was also called ‘bimetallic electrodes’ [i]. When redox couples possess a markedly different → *electrochemical reversibility* at the two electrodes, the potential difference between these two electrodes increases sharply at the equivalence point, which may be used as a sensitive indication of the latter.

Ref.: [i] Lingane JJ (1953) *Electroanalytical chemistry*. Interscience, New York, p 126

Carbon → *carbon*, and → *carbon electrodes*

- Acheson® graphite: → *Acheson® graphite*;
- Boron-doped diamond electrodes: → *boron-doped diamond electrodes*;
- Carbon felt electrode → *carbon*, and → *carbon electrodes*;
- Carbon fiber electrode → *carbon*, and → *carbon electrodes*;
- Carbon nanotubes → *carbon*, and → *carbon electrodes*;
- Carbon paste electrode: → *carbon*, and → *carbon electrodes*;
- Diamond electrodes: → *diamond electrodes*;
- Glassy carbon: See → *glassy carbon electrode*;
- Graphite: See → *graphite electrode*, → *carbon paste electrode*;
- Graphite composites: See → *graphite electrode*;

- Highly oriented pyrolytic graphite: See → *graphite electrode*;
- Paraffin impregnated graphite: See → *paraffin impregnated graphite electrode*.

DT

Gallium — (Ga, atomic number 31) is a silvery-white metal that melts slightly above room temperature. It is one of the few metals (the others being mercury, cesium, and rubidium) that can be liquid near room temperature. It has a low vapor pressure even at high temperatures and expands on solidifying. High-purity gallium is attacked only slowly by mineral acids but passivates under certain conditions of potential and pH [i]. Because of its near-room-temperature melting point, gallium has been used as a solid electrode, a liquid pool electrode, a suspended drop electrode, and as a dropping gallium electrode for → *polarography* [ii]. Gallium electrodes have also been used as → *indicator electrodes* for nonaqueous → *potentiometric titration* of weak acids [iii].

Refs.: [i] Armstrong RD, Race WP, Thirsk HR (1971) *J Electroanal Chem* 31:405; [ii] Giguere PA, Lamontagne D (1954) *Science* 120:390; [iii] Greenhow EJ, Al-Mudarris BF (1975) *Talanta* 22:417

DT

Germanium — (Ge, atomic number 32) is a lustrous, hard, silver-white metalloid (m.p. 938 °C), chemically similar to tin. Ge is a low-band-gap → *semiconductor* that, in its pure state, is crystalline (with the same crystal structure as diamond), brittle, and retains its luster in air at room temperature. Anodic dissolution of the material occurs at potentials more positive than ca. –0.2 V vs SCE. Peaks in the voltammograms of germanium in acidic electrolyte are ascribed to a back-and-forth change between hydrogenated and hydroxylated surfaces [i]. Studies are often conducted at *p*-doped and *n*-doped Ge electrodes [ii] or at Ge alloys (e.g., GeSe) where photoelectrochemical properties have been of considerable interest [iii].

Refs.: [i] Maroun F, Ozanam F, Chazalviel JN (1999) *J Phys Chem B* 103:5280; [ii] Toshima S, Uchida I, Sasaki H (1966) *Denki Kagaku* 34:849; [iii] Le Nagard N, Levy-Clement C, Katty A, Lieth RMA (1990) *Mater Res Bull* 25:495

DT

Glass → *glass electrode*

Gold — (Au, atomic number 79) is a commonly used solid electrode material (melting point = 1065 °C) that is easily fabricated into a variety of → *electrode geometries* [i]. Gold has a significantly larger overpotential for hydrogen reduction than does → *platinum*

though much smaller than for \rightarrow mercury. Additionally, gold does not significantly adsorb hydrogen, thus making it a good choice for the study of cathodic processes [ii]. At positive potentials, Au forms an oxide and/or chemisorbed oxygen layer, while in the presence of complexing anions such as chloride or cyanide, it readily undergoes oxidation and dissolution, limiting its application under such conditions. At high pH, carbohydrates are electrocatalytically oxidized at the surface of a gold electrode, and pulsed amperometric detection of such compounds following their separation by chromatography has been described [iii].

Au crystallizes in the face-centered cubic structure and most applications make use of polycrystalline Au electrodes having random orientation atomic planes or surfaces. For gold, surfaces having Miller Indices (111), (100), and (110), corresponding to hexagonal, square, or rectangular arrangement of atoms, respectively, are typically encountered. Since the microscopic structure of the surface of an electrode plays a fundamental role in determining its electrochemical properties, many studies have been carried out at single crystal Au electrodes, employing the well-defined surface of a single crystal plane [iv].

See also \rightarrow *Activation (of noble metal electrodes)*.

Refs.: [i] Orlik M, Galus Z (2006) *Electrochemistry of gold*. In: Bard AJ, Stratman M, Scholz F, Pickett CJ (eds) *Inorganic electrochemistry. Encyclopedia of electrochemistry, vol. 7b*. Wiley-VCH, Weinheim, pp 839–912; [ii] Sawyer DT, Sobkowiak A, Roberts JL Jr (1995) *Electrochemistry for chemists, 2nd edn*. Wiley Interscience, New York, chap 5; [iii] Neuburger GG, Johnson DC (1987) *Anal Chem* 59:203; [iv] Edens GJ, Hamelin A, Weaver MJ (1996) *J Phys Chem* 100:2322

DT

Intercalation (insertion) electrodes — find widespread application in advanced commercial \rightarrow battery technology. For example, Sony introduced the first commercial lithium rechargeable battery in 1990 which employed LiCoO_2 as the positive electrode material and graphite as the negative electrode material (see \rightarrow *lithium battery*). The operating principle of the electrodes is based on electrochemical insertion/removal (or intercalation/deintercalation, the so-called “rocking chair” concept) of Li^+ ions into/from the electrode material coupled with electron transfer. Other advanced commercial battery systems (e.g., nickel/metal-hydride or rechargeable alkaline manganese oxide) also employ this strategy [i]. The insertion materials used in these applications must exhibit high mobility for the guest ions (e.g., Li^+ ions), must be both an ionic and an electronic conductor, and must possess dimensional stability during the

insertion and subsequent removal of the guest ions. A typical lithium-ion battery combines two Li^+ -ion insertion electrode materials, one exhibiting a low standard redox potential (the negative electrode) and another exhibiting a distinctly higher standard redox potential (the positive electrode) [ii]. Typical lithium-ion batteries use a form of carbon, such as artificial or natural graphite, for the negative electrode. Lithium intercalates between the (2-dimensional) graphite layers during charging, causing the layers to shift in position relative to one another. Transition metal oxides such as LiCoO_2 or LiNiO_2 (with layered or 2-dimensional structures) or LiMn_2O_4 (with a spinel or 3-dimensional structure) are used for the positive electrode [iii]. During discharge of the battery, lithium gives up an electron as it deintercalates from the carbon electrode, then travels as an ion through a nonaqueous (often gel or polymer) electrolyte to the positive electrode (e.g., LiCoO_2), where it recombines with an electron as it intercalates into the positive electrode matrix. See also \rightarrow *insertion electrochemistry*, and \rightarrow *insertion electrodes*.

Refs.: [i] Besenhard JO, Winter M (1998) *Pure Appl Chem* 70:603; [ii] Megahed S, Scrosati B (1994) *J Power Sources* 51:79; [iii] Thackeray MM (2000) *Ceram Trans* 109:263

DT

Iridium — (Ir, atomic number 77) is a highly conductive, brittle, platinum group metal that melts at 2443°C . It is the most corrosion-resistant metal known and is not attacked by any of the acids, including aqua regia, but is attacked by molten salts (such as NaCl and NaCN). Iridium is available in many forms including foil, sheet, wire, powder, and sponge. Ir-based electrodes are used in supercapacitor and electrochromic devices, as well as for the electrocatalysis of chlorine and oxygen evolution. Microelectrodes made of Ir (often alloyed with platinum) are used as stimulating electrodes and as scanning probes.

DT

Iridium dioxide — Iridium oxide crystallizes in the rutile structure and is the best conductor among the transition metal oxides, exhibiting metallic conductivity at room temperature. This material has established itself as a well-known \rightarrow pH sensing [i] and electrochromic [ii] material (\rightarrow *electrochromism*) as well as a catalytic electrode in the production of chlorine and caustic [iii]. The oxide may be prepared thermally [iv] (e.g., by thermal decomposition of suitable precursors at temperatures between 300 and 500°C to form a film on a substrate such as titanium) or by anodic electrodeposition [v].

Refs.: [i] VanHoudt P, Lewandowski Z, Little B (1992) *Biotechnol Bioeng* 40(5):601; [ii] McIntyre JDE, Basu S, Peck WF, Brown WL, Augustyniak WM (1982) *Phys Rev B* 25:7242; [iii] Hayfield PCS (1998) *Platinum Metals Review* 42:46; [iv] Ardizzone S, Carugati A, Trasatti S (1981) *J Electroanal Chem* 126:287; [v] Marzouk SAM, Ufer S, Buck RP, Johnson TA, Dunlap LA, Cascio WE (1998) *Anal Chem* 70:5054

DT

Lead — (Pb, atomic number 82) is a bluish white lustrous metal that melts at 327.5 °C. It is dense, ductile, very soft, highly malleable, and has rather poor electrical → conductivity (ca. 48,000 S/cm at 20 °C). It is very resistant to → corrosion but tarnishes to a dull grey upon exposure to air. Lead is available in several forms including foil, powder, granules, shot, rod, sheet, wire, and ingots. Lead electrodes are used in secondary batteries such as the lead–acid battery (see → *lead–acid accumulator*) and in metal → *electrorefining* (e.g., Cu and Zn → *electrowinning*) [i]. Pb and PbO₂ electrodes have also found application in analytical electrochemistry [ii, iii].
Refs.: [i] Stelter M, Bauer I (1999) *Erzmetall* 52:21; [ii] Stroka J, Maksymiuk K, Galus Z (2006) *Electrochemistry of lead*. In: Bard AJ, Stratman M, Scholz F, Pickett CJ (eds) *Inorganic electrochemistry*. *Encyclopedia of electrochemistry*, vol. 7b. Wiley-VCH, Weinheim, pp 804–838; [iii] Lee JW, Lee YS, Yeo IH (1997) *Anal Sci* 13:273

DT

Lithium → *lithium batteries*

Manganese → *manganese*

Magnesium → *magnesium batteries*, → *magnesium electrochemistry*

Mercury (DME, SMDE, CGME, HMDE, TMFE, mercury pool) — Because of its high → *overpotential* for → *hydrogen evolution* (reduction of → *protons*), mercury (Hg, atomic number 80) is widely used for the study of cathodic processes [i]. Since Hg is readily oxidized, particularly in the presence of anions that complex or form precipitates with Hg(I) or Hg(II) ions, it is seldom used to study anodic processes. A liquid at room temperature (melting point = −38.8 °C), the surface of a Hg electrode is smooth and continuous and does not require the cleaning/polishing or other pretreatment that is common with solid electrodes. Pure Hg should be used, obtained by vacuum distillation, or by electrolytic means. Several configurations of Hg electrodes are common. The → *dropping mercury electrode* (DME) consists of a reservoir of Hg connected to a 10–20 cm glass capillary (ca. 0.05-mm internal diameter) using neoprene or Tygon tubing. Mercury flows dropwise from the capillary with the drop lifetime (typically 1 to 5 s) controlled by the height of the reservoir and/or by a mechanical device (drop knocker) attached to the capillary that dislodges the drop from the capillary at precisely controlled

intervals [ii]. A significant advantage of the DME (and related electrodes below) compared to solid electrodes is that each new drop presents a clean electrode surface.

A more recent device, the static mercury drop electrode (SMDE), uses a fast-response capillary valve to control the drop size (determined by the length of time the valve is open), the drop size remaining static (the valve closed) during the actual measurement. The drop is then dislodged by a drop knocker, the whole process coordinated with a potential pulse or square-wave waveform. This device can also be used as a → *hanging mercury drop electrode* (HMDE) often used for stripping experiments such as → *anodic stripping voltammetry*, where the one or several experiments are performed on a single drop. Other forms of the HMDE are also available, including a device whereby a threaded screw advances into a reservoir, displacing Hg from a capillary which forms a drop at the end [ii].

The controlled growth mercury electrode (CGME) utilizes a fast-response capillary valve to control both the rate of growth and the final size of the Hg drop, the drop being grown by a series of pulses that open the capillary valve. The number of pulses, their duration, and their frequency provide flexibility in both the drop size and its rate of growth. This mode can be used for both polarographic and stripping experiments.

Often used for → *anodic stripping voltammetry* (ASV), the → *thin mercury film electrode* (TMFE) is formed by coating a conducting substrate with a thin layer of mercury, often by electrodeposition from a solution containing Hg(II). Glassy carbon is the most common substrate, although carbon composites, Pt, Ni, Ag, and Ir have also been used [iii]. The electrode area is normally in the range of 0.1 to 0.5 cm² and mercury film thickness typically ranges from 10 to 1000 nm, producing a film of large surface area-to-volume ratio that results in high preconcentration during the deposition step of ASV. The Hg film is often deposited in situ during the deposition step and stripped or removed at the end of each experiment. Compared to the HMDE, the TMFE provides the highest sensitivity and the best resolution, but is somewhat less reproducible and is more prone to interferences from intermetallic formation and surface-active substances [iii]. The use of iridium substrates is reported to improve reproducibility and reliability of the TMFE [iv].

Mercury pool electrodes are usually of sufficient diameter that they are considered to be planar and, thus, obey the theory derived for shrouded (or shielded) planar electrodes. The pool of Hg occupies the entire bottom of the cell or container and electrical contact is usu-

ally established with a platinum wire, often fed through and sealed into the bottom of the cell. Such electrodes have been used as working electrodes and as counter electrodes. The large area of a Hg pool electrode is useful for controlled potential (exhaustive) → *electrolysis* and → *coulometry* [v]. A Hg pool substrate has also been used for → *scanning electrochemical microscopy* [vi]. See also → *mercury and mercury electrode*, → *streaming mercury electrode*.

Refs.: [i] Orlik M, Galus Z (2006) *Electrochemistry of mercury*. In: Bard AJ, Stratman M, Scholz F, Pickett CJ (eds) *Inorganic electrochemistry. Encyclopedia of electrochemistry*, vol. 7b. Wiley-VCH, Weinheim, pp 958–991; [ii] Sawyer DT, Sobkowiak A, Roberts JL Jr (1995) *Electrochemistry for chemists*, 2nd edn. Wiley Interscience, New York, chap 5; [iii] Wang J (1985) *Stripping analysis – Principles, instrumentation and applications*. VCH, Deerfield Beach, chap 3; [iv] Tercier M-L, Parthasarathy N, Buffle J (1995) *Electroanalysis* 7:55; [v] Peters DG, Burden SL (1966) *Anal Chem* 38:530; [vi] Mirkin MV, Bard AJ (1992) *J Electrochem Soc* 139:3535

DT

Nickel — (Ni, atomic number 28) is a silvery white metal that melts at 1455 °C. It is hard, malleable, ductile, and ferromagnetic. Nickel is available in many forms including foil, powder, flakes, sheet, wire, mesh, spheres, and rods. Nickel electrodes find extensive use in rechargeable alkaline batteries such as Ni–Zn, → *Ni–Cd* and → *Ni–MH* batteries [i]. In these applications, the (simplified) reaction taking place at the Ni electrode is:

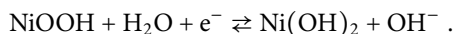

Ni electrodes have also been used in analytical electrochemistry, especially for the electrochemical detection of carbohydrates following separation by HPLC. Both Ni [ii] and Ni alloy [iii] electrodes have been used. The mechanism appears to involve the NiOOH species that oxidizes the carbohydrate in an → *EC'* catalytic sequence [iii].

Refs.: [i] Horányi G, Inzelt G (2006) *The nickel group (nickel, palladium, and platinum)*. In: Bard AJ, Stratman M, Scholz F, Pickett CJ (eds) *Inorganic electrochemistry. Encyclopedia of electrochemistry*, vol. 7a. Wiley-VCH, Weinheim, pp 497–528; [ii] Buchberger W, Winsauer K, Breitwieser C (1983) *Fresenius' Z Anal Chem* 315:518; [iii] Luo PF, Kuwana T (1994) *Anal Chem* 66:2775

DT

ORTA — refers to an oxidized ruthenium titanium anode (ORTA) whereby a titanium substrate is covered by ruthenium dioxide. ORTA is the term commonly encountered in the Russian literature, whereas the term → *dimensionally stable electrode* (anode) (DSA) is used in the English literature [i] (although DSA can also refer to a Ti substrate covered with a multi-metal

oxide layer). ORTA anodes have a low overvoltage for Cl₂ and O₂ evolution, with the kinetics of the electrochemical reactions depending on the composition of the oxide coating (the rate increases with increase in the RuO₂ concentration in the coating) [ii]. Such electrodes are used in a variety of applications, including electrochemical synthesis, cathodic protection, water purification, and electrowinning of metals.

Refs.: [i] Antonov VN, Bystrov VI, Avksent'ev VV, Yurkov LI, Kubasov VL (1974) *Khim Promst* 8:600; [ii] Andreev VN, Kokoulina DV, Krasovitskaya YI, Kazarinov VE, Krishtalik LI (1978) *Dvoinoi sloi i adsorbtsiya na tverdykh elektrodakh* 5:13

DT

Palladium — (Pd, atomic number 46) is a silvery white metal (melting point = 1552 °C) that is commercially available in many polycrystalline forms, including wire, rod, foil, powder, sheet, and sponge. The basic electrochemical response of Pd is generally considered to be similar to that of → *platinum* [i], apart from its behavior in acidic solutions at low potential which is attributed to its ability to absorb/desorb large quantities (up to 30 volumes) of hydrogen. However, Pd is more prone to dissolution and to hydrous oxide growth, including formation of the higher oxide PdO₃ [ii]. Pd is occasionally used as the working electrode for voltammetric studies (although Pt and Au are much more commonly used), but is not recommended for use as a cathode in protic solvents due to its extremely small overpotential for hydrogen evolution and its ability to absorb hydrogen. In fact, the ability of Pd to absorb hydrogen forms the basis of a palladium–hydrogen → *reference electrode* [iii]. See also → *cold fusion*.

Refs.: [i] Horányi G, Inzelt G (2006) *The nickel group (nickel, palladium, and platinum)*. In: Bard AJ, Stratman M, Scholz F, Pickett CJ (eds) *Inorganic electrochemistry. Encyclopedia of electrochemistry*, vol. 7a. Wiley-VCH, Weinheim, pp 497–528; [ii] Burke LD, Casey JK (1993) *J Electrochem Soc* 140:1284; [iii] Fleischmann M, Hiddleston JN (1968) *J Sci Instrum Series* 2 1:667

DT

Platinized platinum — Metallic platinum covered with a rough large-surface-area platinum coating. The very well-developed metal surface results in a Pt → *electrode* of a large true area that is relatively nonpolarizable. A platinized platinum electrode can be obtained by cathodic → *electrodeposition* of a rough Pt deposit at Pt-metal electrode from a solution consisting of chloroplatinic acid (3%), lead acetate (0.025%), and hydrochloric acid (ca. 1%) The name of this electrodeposited coating → *platinum black* comes from deep black color and dull surface of the deposit. In fact, the dark black color appears when lead is used as an additive. When pure

hexachloroplatinate solution is used for platinizing the platinum electrode the deposit is grey. Platinized platinum is used in all types of \rightarrow *hydrogen electrodes* as conducting material for the hydrogen redox couple, and as electrodes for AC \rightarrow *conductivity* measurements.

Refs.: [i] Mils A (2006) *Bull Sci Instrum Soc* 89:35; [ii] Feltham AM, Spiro M (1971) *Chem Rev* 71:177

MD

Platinum — (Pt, atomic number 78) is a malleable and ductile silvery-white metal (melting point = 1768 °C) that is commercially available in many polycrystalline forms, including wire, rod, foil, powder, sheet, sponge, and mesh (a variety of Pt alloys are also available). Platinum has a coefficient of expansion very similar to that of soda-lime-silica glass, facilitating the fabrication of sealed-in-glass electrode systems. Pt is insoluble in hydrochloric and nitric acid, but dissolves in a mixture of these acids, forming chloroplatinic acid (H_2PtCl_6).

Pt is the most commonly used metallic working electrode for voltammetric studies [i]. Pt (like Pd) has a very small overpotential for hydrogen evolution (hence its use in constructing reversible \rightarrow *hydrogen electrodes*), and in protic solvents this reaction determines the negative potential limit. Pt adsorbs hydrogen, resulting in hydrogen adsorption/desorption waves in the voltammogram, a phenomenon that has been used to determine the surface area of the Pt [ii]. The positive potential limit in polar aprotic solvents free of oxygen and water is larger than for any other commonly used electrode material [ii]. In the presence of water and/or oxygen, Pt forms a film of oxide (and/or chemisorbed oxygen) at positive potentials, resulting in potentially interfering waves in the voltammogram.

Platinum also finds widespread application in other areas of electrochemistry where its catalytic properties are utilized. For example, the electrochemical reactions in fuel cells generally have high activation energies, and Pt-based electrodes are often employed [iii]. See also \rightarrow *Activation (of noble metal electrodes)*.

Refs.: [i] Horányi G, Inzelt G (2006) *The nickel group (nickel, palladium, and platinum)*. In: Bard AJ, Stratman M, Scholz F, Pickett CJ (eds) *Inorganic electrochemistry. Encyclopedia of electrochemistry, vol. 7a*. Wiley-VCH, Weinheim, pp 497–528; [ii] Sawyer DT, Sobkowiak A, Roberts JL Jr (1995) *Electrochemistry for chemists, 2nd edn*. Wiley Interscience, New York, chap 5; [iii] Hoogers G (ed) (2002) *Fuel cell technology handbook*. CRC Press, Boca Raton

DT

Platinum black — The original name of highly dispersed platinum. For electrochemists the most usual type of platinum black is the \rightarrow *platinized platinum* elec-

trode fabricated by means of platinum electrodeposition from chloroplatinate solutions with addition of copper or lead salts [i], later extended to other types of dispersed platinum (not obligatory black; bright and gray deposits can also have very high surface area). The catalytic activity of finely dispersed platinum was first discovered by J.W. Döbereiner (1780–1849). Later, platinum black found a wide electrochemical application owing to the studies of \rightarrow *Kohlrausch* [ii], who used these materials for precise measurements of solution conductivity. The hydrogen electrode ($\text{H}_2/2\text{H}^+$) is known to be highly reversible at Pt black, and the latter is a unique model system for \rightarrow *electrocatalysis* and surface thermodynamics. Effects of various deposition parameters on the properties of Pt black are reviewed in [iii]. Deposition procedures recommended in this review are mostly based on lead-containing baths, but lead additives are not obligatory for fabricating stable and highly dispersed materials. Well-reproducible deposits can be obtained from solutions of various complex species of both Pt(II) and Pt(IV) with a proper choice of deposition mode, especially the deposition potential. The latter affects the current efficiency, the rate of nucleation-growth events (\rightarrow *nucleation and growth kinetics*), and the \rightarrow *surface tension* responsible for more or less coalesced nanocrystals. By these means it affects indirectly the deposit specific surface area, defectiveness, and texture. Lattice compression is typical for electrodeposited platinum and is more pronounced for more coalesced deposits. Anomalous and less dispersed deposits sometimes form under conditions of parallel hydrogen evolution. A specific feature of Pt black and relative highly dispersed materials is the existence of pores of 1–3 nm diameter [iv]. True surface area of freshly prepared Pt black (sometimes approaching dozens of $\text{m}^2 \text{g}^{-1}$) decreases with time. Details of deposit ageing depend on the medium and \rightarrow *polarization* mode, the steady-state values can be an order lower than initial. Ageing results from coalescence of nm-size crystals providing the decrease of free energy (Ostwald ripening). Deposit morphology and microstructure manifest themselves in various electrochemical responses, including the effect on electrocatalytic activity [v–vii]. Platinized platinum electrodes are discussed in detail in [viii].

Refs.: [i] Kurlbaum F, Lummer O (1895) *Verh Phys Ges Berlin* 14:56; [ii] Kohlrausch F (1897) *Ann Phys Chem* 60:315; [iii] Feltham AM, Spiro M (1971) *Chem Rev* 71:177; [iv] Gladysheva TD, Shkol'nikov, Volfkovich YuM, Podlovchenko BI (1982) *Elektrokimiya* 18:435; [v] Petrii OA, Tsirlina GA, Pron'kin SN (1999) *Russ J Electrochem* 35:8; [vi] Whalen JJ III, Weiland JD, Searson PC (2005) *J Electrochem Soc* 152:C738; [vii] Plyasova LM, Molina YuI, Gavrilov AN,

Cherepanova SV, Cherstiouk OV, Rudina NA, Savinova ER, Tsirlina GA (2006) *Electrochim Acta* 51:4477; [viii] Inzelt G, Horányi G (2006) *The nickel group (nickel, palladium, and platinum)*. In: Bard AJ, Stratmann M, Scholz F, Pickett CJ (eds) *Inorganic electrochemistry. Encyclopedia of electrochemistry*, vol. 7a. Wiley-VCH, Weinheim, p 515

OP

Platinum–ruthenium — Electrocatalysts (\rightarrow *electrocatalysis*) with pronounced synergetic effect towards a number of \rightarrow *fuel cell* reactions. Its ability to enhance the methanol oxidation by 2 to 3 orders of magnitude was discovered in the early 1960s [i, ii]. The effect appears at low anodic potentials (up to 0.4 V RHE) already when 5–10 at % of Ru is added to Pt. The catalytic effect was assigned to a bifunctional mechanism [iii] assuming the formation of active oxygen species on ruthenium centers and chemisorbed methanol species at platinum centers. Chemical interaction of oxygen- and carbon-containing species is believed to be a limiting step of methanol oxidation in a certain potential range. Currently available Pt–Ru catalysts include surface-modified materials (\rightarrow *adatoms* of Pt on Ru and vice versa, decorated \rightarrow *nanoparticles*), core-shell and mixed \rightarrow *colloids*, as well as more bulky materials. The Pt–Ru binary system is known to form two continuous sequences of solid solutions (fcc and hcp structures for predominating Pt and Ru, respectively) with a narrow two-phase region in between, but no phase diagram is available for the room temperature region. Starting from the 1990s, Pt–Ru catalysts have attracted intensive attention in the context of direct \rightarrow *methanol* fuel cell problems. Numerous fabrication techniques were elaborated and optimized for highly dispersed alloys on various supports, and isolated nanoparticles (templated deposition, nanoparticles generation at \rightarrow *liquid/liquid interface*, exploiting of special molecular precursors, advanced sol–gel techniques, colloid immobilization). Pt–Ru deposits on dispersed carbons are considered as the most prospective. A key problem of their operation is ruthenium crossover in the cells with solid \rightarrow *polymer electrolyte* (Ru anodic dissolution with subsequent diffusion of dissolved species and Ru deposition at fuel cell cathode, with deterioration of electrolyte and cathode). Another phenomenon leading to catalyst degradation is the change of nanoparticles size and clustering of Ru atoms. For elevated temperatures, Pt surface segregation is typical. Methanol oxidation on Pt–Ru is known for highly selective formation of carbon dioxide, but formic acid, methyl formate, formaldehyde, and methyl aldehyde also can be formed under certain conditions (being undesirable for both fuel cell operation and for the environment). Both metallic Ru and surface

oxo-hydroxo ruthenium species RuO_xH_y are assumed by various authors as the active components. Optimal Pt:Ru ratio depends on the type of catalyst and reactant nature, usually higher Ru content is required at higher temperatures. Pt–Ru anodes are also of interest for hydrogen fuel cells consuming CO-contaminated hydrogen produced by reforming. The reason is faster CO oxidation on Pt–Ru as compared to Pt. Future improvement of the Pt–Ru system is expected to result from using ternary systems (like Pt–Ru–Mo, Pt–Ru– W_2C , Pt–Ru– WO_x , Pt–Ru–Sn, Pt–Ru–Ni, etc.) with higher activity/price ratio [iv]. Computational studies of synergism in electrocatalysis are strongly attached to Pt–Ru as a model system [v].

Refs.: [i] Cohn JGE, Adlhart OJ (1965) *Fuel cells*. Belg Pat 650,651, Jan 18; US Appl, July 17, 1963, 33 pp; Adlhart OJ, Shields H, Pudick S (1965) *Engelhard Ind Tech Bull* 6(2):37; [ii] Petrii OA (1965) *Dokl AN SSSR* 160:871; [iii] Watanabe M, Suzuki T, Motoo S (1970) *Denki Kagaku* 38:927; [iii] Watanabe M, Motoo S (1975) *J Electroanal Chem* 60:267; [iv] Vielstich W, Lamm A, Gasteiger H (eds) (2003) *Handbook of fuel cell technology*. Wiley, New York; [v] Desai S, Neurock M (2003) *Electrochim Acta* 48:3759

OP

Rhodium — (Rh, atomic number 45) is a silvery white metal (melting point = 1966 °C) that is available in several forms, including foil, sponge, powder (rhodium black), and wire. Rhodium is a major component of industrial catalytic systems (e.g., the BP-Monsanto process for ethanol synthesis from methanol and carbon dioxide). Working electrodes based on Rh include carbon electrodes modified with particles of rhodium, electrodeposited Rh films on glassy carbon, and vacuum-deposited layers of rhodium on gold [i], to achieve low potentials for the amperometric detection of hydrogen peroxide. Polycrystalline Rh electrodes have been used [ii, iii] (e.g., for the electrochemical reduction of benzene) as have single crystal electrodes [iv].

Refs.: [i] Janasek D, Vastarela W, Spohn U, Teuscher N, Heilmann A (2002) *Anal Bioanal Chem* 374:1267; [ii] Liu G, Yao J, Ren B, Gu R, Tian Z (2002) *Electrochem Comm* 4:392; [iii] Méndez E, Luna AMC, Cerdá MF, Mombrú AW, Zinola CF, Martins ME (2003) *J Solid State Electrochem* 7:208; [iv] Lapa AS, Safonov VA, Petrii OA, Korenovskii NL (1984) *Elektrokhimiya* 20:1550

DT

Semiconductor electrodes \rightarrow *Semiconductors* are materials that have electrical conductivity that is lower than that of metals but higher than that of insulators. Such materials are characterized by a large number of closely spaced, low-energy, mainly filled orbitals or energy levels (the valence band) and a large number of closely spaced, higher-energy, mainly vacant or

bitals or energy levels (the conduction band). The energy gap between the highest level in the valence band and the lowest level in the conduction band is called the bandgap. Metals have a bandgap of essentially 0 eV; that is to say, the \rightarrow Fermi level lies within the conduction band (thus, the band is only half filled) and only a very small amount of energy is needed for the electrons to move into other unoccupied states or for current to flow [i]. Insulators have a bandgap of greater than ca. 4 eV (although some materials with a bandgap greater than 4 eV are called wide bandgap semiconductors). Semiconductors are materials that have a bandgap between 0 and ca. 4 eV, such that the conduction band is only slightly thermally populated with electrons at room temperature. Examples of elemental semiconductors include antimony, arsenic, boron, carbon, germanium, selenium, silicon, sulfur, and tellurium. Common semiconductor compounds include gallium arsenide, indium antimonide, aluminum phosphide, and the oxides of most metals.

An “undoped” or pure semiconductor material is called an **intrinsic** semiconductor. Dopants (or impurities) are often added at very low concentration to modify the type and/or number of charge carriers in the material (i.e., adjust the Fermi level). There are two types of semiconductor materials, *n-type* in which the majority charge carriers are (negative) electrons, and *p-type* in which the majority charge carriers are (positive) holes or electron deficiencies. Most (but not all) semiconducting metal oxides are of the *n-type*.

A major difference between electrochemistry performed at metal electrodes and that performed at semiconductor electrodes is that for a metal electrode, all the potential drop appears on the solution side of the metal-electrolyte interface, whereas for a semiconductor electrode, a portion of the potential drop occurs within the semiconductor material near the interface (within the so-called depletion or space-charge region, typically 10 nm to 1 μ m thick). This additional “built-in” barrier to charge transfer at the interface means that the standard diagnostics for reversible electrochemical behavior are not applicable at a semiconductor electrode [ii].

Semiconductor electrodes are used extensively in the field known as \rightarrow *photoelectrochemistry* [ii, iii], in which light of energy greater than the bandgap energy is used to carry out a photoassisted electron transfer reaction at the electrode/electrolyte interface. Photons are absorbed by the semiconductor, resulting in the creation of electron-hole pairs in the space-charge region. The electric field within the space-charge region promotes the separation of the electrons and the holes, with the

holes moving to the electrolyte interface for an *n-type* material, electrons moving to the interface for a *p-type* material. Thus, *n-type* semiconductor electrodes function as photoanodes, while *p-type* semiconductor electrodes function as photocathodes. Light energy helps drive the electron transfer reaction(s), and these photo-assisted electrode reactions occur at less positive (for an oxidation) or less negative (for a reduction) potential than at a metal electrode. Thus, semiconductor electrodes are being used to develop photoelectrochemical energy conversion, often using dye sensitization or other light harvesting strategies [iii].

Refs.: [i] Simpson RE (1987) *Introductory electronics for scientists and engineers*, 2nd edn. Allyn and Bacon, Boston, chap 4; [ii] Bockris AB, Tachikawa H, Faulkner LB (1996) In: *Laboratory techniques in electroanalytical chemistry*, 2nd edn. Marcel Dekker, New York, chap 28; [iii] Bard AJ, Stratmann M, Licht S (eds) (2002) *Semiconductor electrodes and photoelectrochemistry*. *Encyclopedia of electrochemistry*, vol. 6. Wiley-VCH, Weinheim

DT

Silicon — (Si, atomic number 14) is a tetravalent metalloid having a dark-gray color with a metallic luster. A solid at room temperature (melting point = 1414 °C), it is the second most abundant element in the Earth’s crust (25.7% by weight), usually found as silica (SiO₂). Si is commercially available as polycrystalline foils (sheets) as well as single crystal foils and wafers of various crystal face orientations. It is also available in powder form. Highly pure (99.999%) silicon is an intrinsic semiconductor, but it is usually doped with boron, gallium, phosphorus, or arsenic for use in transistors, solar cells, rectifiers, and other solid-state electronic devices. Such \rightarrow *semiconductor electrode* materials also find extensive use in \rightarrow *photoelectrochemistry*.

Semiconductor fabrication techniques permit the feature size of Si-based devices to reach into the deep submicron regime [i]. Additionally, Si can be anodized electrochemically or chemically (e.g., in an HF-containing electrolyte) to produce a sponge-like porous layer of silicon, with pore dimensions that range from several microns in width to only a few nanometers [ii]. These properties of Si make it a useful substrate for fabricating sensor platforms, photonic devices and fuel cell electrodes [iii].

Refs.: [i] Zhao Q, Luo Y, Surthi S, Li Q, Mathur G, Gowda S, Larson PR, Johnson MB, Misra V (2005) *Nanotechnology* 16:257; [ii] Zhang XG (2001) *Electrochemistry of silicon and its oxide*. Plenum, New York; [iii] Chemla M (2006) *Silicon*. In: Bard AJ, Stratman M, Scholz F, Pickett CJ (eds) *Inorganic electrochemistry*. *Encyclopedia of electrochemistry*, vol. 7a. Wiley-VCH, Weinheim, pp 303–332

DT

Silver — (Ag, atomic number 47) is a soft, white, lustrous metal that has the highest electrical and thermal conductivity (and the lowest contact resistance) of any metal. A solid at room temperature (melting point = 961.8 °C), Ag is commercially available in several forms, including foil, mesh, wire, rod, tube, powder, pellets, and single crystal. It is also available as an alloy with each of several metals, including Ni, Cu, Pd, Sn, Au, and Sb.

Silver electrodes were first used in → *potentiometry* for the determination of pAg, pBr, pCl, and pI, especially in photographic science and technology. Voltammetric studies using both polycrystalline and single crystal electrodes have been conducted since the 1940s where, for the most part, the adsorption characteristics of Ag electrodes (similar to that of mercury) were considered [i]. A review of voltammetry at Ag electrodes (including film, single-crystal, polycrystalline, and paste electrodes) from 1960 to 2000 has recently appeared [i]. Ag electrodes are also used for the electrochemical detection of bromide, iodide, sulfide, thiosulfate, cyanide, and thiocyanate following anion-exchange chromatography.

The silver–silver chloride → *reference electrode* is one of the most reproducible and reliable reference electrodes for use in aqueous solutions, as well as one of the easiest to construct and use [ii]. For nonaqueous solutions, the silver–silver ion reference electrode is widely used. It appears to be reversible in all aprotic solvents except those oxidized by silver ion [ii]. The electrochemistry of silver is discussed in detail in [iii].

Refs.: [i] Gorokhovskii VM (2003) *J Anal Chem* 58:198; [ii] Sawyer DT, Sobkowiak A, Roberts JL Jr (1995) *Electrochemistry for chemists*, 2nd edn. Wiley Interscience, New York, chap 5; [iii] Orlik M, Galus Z (2006) *Electrochemistry of silver*. In: Bard AJ, Stratman M, Scholz F, Pickett CJ (eds) *Inorganic electrochemistry. Encyclopedia of electrochemistry*, vol. 7b. Wiley-VCH, Weinheim, pp 913–957

DT

Tetracyanoquinodimethane electrodes — Tetracyanoquinodimethane (TCNQ) and many of its derivatives are easily reduced to anions of the type TCNQ[−], which form salts with various cations. With many cations, e.g., tetrathiafulvalene cations (TTF⁺), and *N*-methyl phenazinium cations (NMP⁺), the TCNQ[−] anions form electronically conducting salts (→ *molecular metals*, → *charge-transfer complexes*) that can be used as electrodes, especially because of their electrocatalytic properties (→ *biosensors*, → *electrocatalysis*, → *molecular metals*) [i, ii]. TCNQ undergoes insertion electrochemical reactions (→ *insertion electrochemistry*) leading to TCNQ salts [iii, iv]. Polymers

containing TCNQ units in the polymer chain have also been thoroughly investigated [v].

Refs.: [i] Oguro F, Otsubo T (1997) *Conducting hetero-TCNQs*. In: Nalwa HS (ed) *Organic conducting molecules and polymers*, vol. 1. Wiley, Chichester, pp 229; [ii] Bartlett PN (1990) *Conducting organic salt electrodes*. In: Cass AEG (ed) *Biosensors. A practical approach*. Oxford University Press, Oxford, pp 47; [iii] Bond AM, Fletcher S, Marken F, Shaw SJ, Symons PG (1996) *J Chem Soc Faraday Trans* 92(20):3925; [iv] Bond AM, Fletcher S, Symons PG (1998) *Analyst* 123:1891; [v] Inzelt G (1994) *Charge transport in polymer-modified electrodes*. In: Bard AJ (ed) *Electroanalytical chemistry*, vol. 18, Marcel Dekker, New York, pp 158–182

FS

Tetrathiafulvalene electrodes — Tetrathiafulvalene (TTF) and many of its derivatives are easily oxidized to form cations of the type TTF⁺. With various anions, most prominent is the tetracyanoquinodimethane anion (TCNQ[−]), these cations form → *charge-transfer complexes*, i.e., salts with metal-like conductivities (→ *molecular metals*). These salts are used in electrochemistry as electrodes or to modify the surface of electrodes, for the purpose of achieving desirable electrocatalytic properties (→ *electrocatalysis*). Tetrathiafulvalene-substituted polystyrenes have also been synthesized and used as modified electrodes [ii].

See also → *tetracyanoquinodimethane electrodes*.

Refs.: [i] Papavassiliou GC, Terzis A, Delhaes P (1997) *Tetrachalcogenafulvalenes, metal 1,2-dichalcogenolenes and their conducting salts*. In: Nalwa HS (ed) *Organic conducting molecules and polymers*, vol. 1. Wiley, Chichester, pp 151; [ii] Inzelt G (1994) *Charge transport in polymer-modified electrodes*. In: Bard AJ (ed) *Electroanalytical chemistry*, vol. 18, Marcel Dekker, New York, pp 157–158

FS

Tungsten carbide — WC, belongs to a class of Group IV B–VI B transition metal carbides and nitrides, often referred to as interstitial alloys, in which the carbon and nitrogen atoms occupy the interstitial lattice positions of the metal [i]. These compounds possess properties known from group VIII B precious metals like platinum and palladium [ii]. Thus, they show remarkable catalytic activities, attributed to a distinct electronic structure induced by the presence of carbon or nitrogen in the metal lattice. Tungsten carbide resembles platinum in its electrocatalytic oxidation activity (→ *electrocatalysis*) and is therefore often considered as an inexpensive anode electrocatalyst for → *fuel cell* [iii] and → *biofuel cell* [iv] application.

Refs.: [i] Oyama ST, Clark P, Wang X, Shido T, Iwasawa Y, Hayashi S, Ramallo-Lopez JM, Requejo FG (2002) *J Phys Chem B* 106: 1913; Iglesia E, Ribeiro FH, Boudart M, Baumgartner JE (1992) *Catal Today* 15: 307; [ii] Levy RB, Boudart M (1973) *Science* 181:547; [iii] Böhm H,

Pohl FA (1968) *Wiss Ber AEG-Telefunken* 41:46; [iv] Rosenbaum M, Zhao F, Schröder U, Scholz F (2006) *Angew Chem int Ed* 45:6658

US

Zinc → zinc

E

Electrode potential → *potential*, subentry → *electrode potential*

Electrode processes — Electrode processes involve all the changes and processes occurring at the electrode or in its vicinity while current flows through the cell. Electrode processes consist of the → *electrode reaction* and the → *mass transport processes* [i–v].

Refs.: [i] Inzelt G (2002) *Kinetics of electrochemical reactions*. In: Scholz F (ed) *Electroanalytical methods*. Springer, Berlin, pp 29–30; [ii] Erdey-Grúz T (1972) *Kinetics of electrode processes*. Akadémiai Kiadó, Budapest, pp 17–20; [iii] Bard AJ, Faulkner LR (2001) *Electrochemical methods*. 2nd edn. Wiley, New York, pp 49–52; [iv] Parsons R (1974) *Pure Appl Chem* 37:503; [v] Parsons R (1979) *Pure Appl Chem* 52:233

GI

Electrode reaction — The electrode reaction is an interfacial reaction (see → *interface*) that necessarily involves a → *charge transfer step*. The electrode (or interfacial) reaction involves all the processes (chemical reaction, structural reorganization, → *adsorption*) accompanying the charge transfer step. The rate of this type of reaction is determined by one of the consecutive steps (i.e., by the most hindered or “slowest” one) and the overall rate is related to the unit area of the interface [i–v].

Refs.: [i] Inzelt G (2002) *Kinetics of electrochemical reactions*. In: Scholz F (ed) *Electroanalytical methods*. Springer, Berlin, pp 29–30; [ii] Erdey-Grúz T (1972) *Kinetics of electrode processes*. Akadémiai Kiadó, Budapest, pp 17–20; [iii] Bard AJ, Faulkner LR (2001) *Electrochemical methods*. 2nd edn. Wiley, New York, pp 49–52; [iv] Parsons R (1974) *Pure Appl Chem* 37:503; [v] Parsons R (1979) *Pure Appl Chem* 52:233

GI

Electrode surface area — The area of the → *interface* between the ionically conducting phase (electrolyte solution, molten salt electrolyte etc.) and the electronically conducting phase (metal, semiconductor etc.);

Electrode surface area, geometric — The interfacial area A_{geom} determined based on the assumption that the interface is truly flat (2-dimensional), mostly calculated using the geometric data of the involved parts (i.e., surfaces are of a metal sheet, disk, or the surface of a metal drop assuming a certain drop shape);

Electrode surface area, real (true) — Actual surface area A_{real} taking into account the nonidealities of the interface (roughness, porosity etc.) can be measured with a variety of electrochemical methods. The

→ *double-layer capacitance* as determined with various AC techniques is a good measure provided that frequency dispersion is taken into account. With very porous electrodes and poorly conducting electrolyte solutions the inner surface area of a porous electrode wetted with electrolyte solution may not be taken into account properly because of the limited depth of penetration of AC methods in particular at high frequencies. The amount of charge associated with e.g., → *hydrogen adsorption* or → *underpotential deposition* of metals can also be employed. From the detected amount of charge and an assumed number of adsorption sites on an ideally smooth surface on a particular geometric arrangement of atoms in the adsorbing surface (i.e., a particular crystallographic orientation) the true surface area can be calculated. The ratio $A_{\text{real}}/A_{\text{geom}}$ is called → *roughness factor* f_r .

Refs.: [i] Yeager E, Salkind AJ (eds) (1972) *Techniques of electrochemistry*, vol. 1. Wiley Interscience, New York; [ii] Ho JCK, Piron DL (1994) *J Electrochem Soc* 142:1144; [iii] Lasia A (1995) *Polish J Chem* 69:639; [iv] Angerstein-Kozłowska H (1984) *Surfaces, cells, and solutions for kinetics studies*. In: Yeager E, Bockris JO'M, Conway BE, Sarangapani S (eds) *Comprehensive treatise of electrochemistry*, vol. 9. Plenum Press, New York, p 15; [v] Jarzabek G, Borkowska Z (1997) *Electrochim Acta* 42:2915; [vi] Saffarian HM, Srinivasan R, Chu D, Gilman S (1998) *Electrochim Acta* 44:1447; [vii] Bai L, Gao L, Conway BE (1993) *J Chem Soc Faraday Trans* 89:243; [viii] Parsons R (1974) *Pure Appl Chem* 37:503

RH

Electrodecantation — Application of the electrophoretic effect (→ *electrophoresis*) to concentrate a suspension of particles in a liquid by collecting the particles near one of the two electrodes used to apply a voltage across the cell containing the suspension.

FS

Electrodeposition — Electrodeposition is the process of forming a film or a bulk material using an electrochemical process where the electrons are supplied by an external power supply. It is an important surface finishing procedure and in the broadest sense comprises the deposition of metals, alloys, oxides, polymers, and composites.

Electrodeposition is also utilized in → *electroanalysis*, especially in → *electrogravimetry*, → *stripping voltammetry*.

Refs.: [i] Schlesinger M, Paunovic M (2000) *Modern electroplating*. 4th edn. Wiley, New York; [ii] Paunovic M, Schlesinger M (2006) *Fundamentals of electrochemical deposition*, 2nd edn. Wiley, New York

AB

Electrodialysis — In electrodialysis electrically charged → *membranes* and an electrical → *potential* difference are used to separate ionic species from an aqueous solution and uncharged components. It refers to an industrial-scale process of electrolyte concentration/depletion due to separation on anion- and cation-exchange membranes under the influence of an electric field. The electrodialysis cell is constructed like a bipolar filter-press electrolyzer, with anion-exchange membranes sandwiched alternately with cation-exchange membranes, see following Figure.

Only the two end chambers are fitted with electrodes. The separation results from the migration of ions under the influence of the electric field established by the cell voltage between the end electrodes. Cations and anions of the electrolyte can migrate in opposite directions toward the anode and cathode, respectively. Due to the alternating arrangement of the membranes,

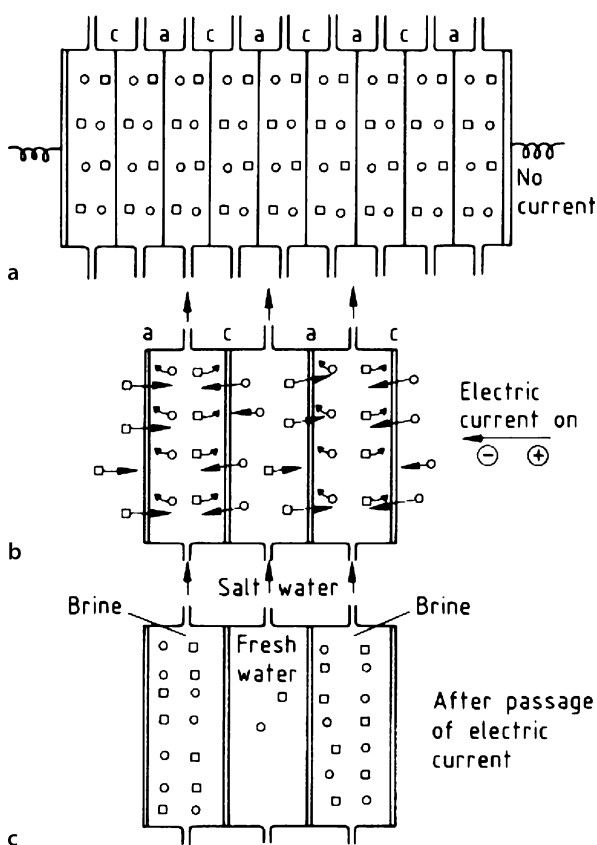

Electrodialysis — Figure. The electrodialysis cell (a) [i]: (a = anion-permeable membrane; c = cation-permeable membrane; ○ = positive ion; □ = negative ion; ion migration under action of electrical current (b), causes salt depletion in alternate compartments and salt enrichment in adjacent ones (c))

alternate compartments become depleted and enriched in electrolyte.

The most significant large-scale application of electrodialysis is the → *desalination* of water or removal of ionic pollutants from aqueous wastewaters, but using the same cell design with ion-exchange membrane, impermeable to the protein, it can also be used to remove salt from protein solutions, possibly after precipitation. Potable water production from brackish water is most economic for waters with relatively low salt concentration, i.e., <5000 ppm. Electrodialysis competes in several fields with reverse → *osmosis*. Generally, it finds less technical applications than the latter, but possesses a number of benefits, as higher thermal and chemical tolerance of the membranes, i.e., utilization at severer pH conditions and/or elevated temperatures. Furthermore, high brine concentrations of 18–20% (wt), i.e., close to the point of salt precipitation, can easily be achieved. Therefore, this technique is used mainly in Japan for the production of table salt from seawater. It is also utilized in industrial wastewater treatment, to process rinse waters from the → *electroplating* industry, since the water and the respective metal ions can be recycled. A drawback in this context is that only ionic components, but not the galvanic bath additives, can be removed. The removal of tartaric acid from wine in the production of bottled champagne, or partial demineralization of whey, shall exemplarily be quoted as applications of electrodialysis in the food industry.

Refs.: [i] Spiegler KS (1980) *Salt water purification*, 2nd edn. McGraw-Hill, New York; [ii] Korngold E, Kock K, Strathmann H (1978) *Desalination* 24:129; [iii] McRae WA (1983) *Electrodialysis*. In: Porteous A (ed) *Desalination technology developments and practice*. Applied Science, London, pp 249–264; [iv] Strathmann H (2002) *Membranes and membrane separation processes*. In: *Ullmann's encyclopedia of industrial chemistry*, 6th edn. Wiley-VCH; [v] Levy J, Morgan J, Brown E (2004) *Oxford handbook of dialysis*. Oxford University Press

MHer

Electrodissolution — Electrodissolution is the electrochemical dissolution of a material to soluble species. It can be regarded as the reversal of → *electrodeposition*. While most metals dissolve anodically, oxide films usually dissolve cathodically. In an electrochemical cell one can have electrodeposition on one electrode (typically the cathode) and electrodissolution at the other (typically the anode). Prominent examples for combined electrodissolution/electrodeposition processes are the → *electrorefining* of copper or metal plating involving the utilization of soluble anodes. A high-precision technical application of electrodissolution is → *electrochem-*

ical machining. Reductive electrodisolutions are encountered for certain applications of \rightarrow *electroanalytical chemistry*.

AB

E

Electrodeics — This term has been suggested by Bockris for that branch of electrochemistry that concerns the thermodynamics and kinetics of processes at charged interfaces, i.e., electrodes.

Refs.: [i] Bockris JO'M, Reddy AKN, Gamboa-Aldeco M (2000) *Modern electrochemistry, fundamentals of electrodic*, vol. 2a, 2nd edn., Kluwer Plenum, New York

FS

Electrodeics \rightarrow *Electroosmosis*

Electroflotation — Process to float solid suspensions, emulsions, or colloidal particles of organic matter in waste waters, using the gases (e.g., H₂, O₂) generated by electrolysis of the polluted aqueous medium. The hydrophobic contaminants are attached to the rising gas bubbles generated by the electrode reactions and mechanically carried upwards to the water surface. The resulting scum is skimmed out of the electrolytic cell. To improve the process efficiency, instead of inert anodes, aluminum or iron anodes are often used, coupling electroflotation with electrocoagulation. The released trivalent metal ions (Al³⁺ or Fe³⁺ from partially converted Fe²⁺), the products of the anodic reaction, form hydroxides, polyhydroxides, and polyhydroxymetallic compounds that cause the coagulation of the dispersed colloidal solids, easing the flotation process (when the size of particles and gas bubbles are of the same order, the probability of collision increases). Electrocoagulation is also useful for heavy metal removal, reduction of phosphorus content, and in water de-fluorination. According to the specific characteristics of the effluent that requires purification, several adequate combinations of electrocoagulation/electroflotation cells can be assembled to perform an effective decontamination process.

Refs.: [i] Rajeshwar K, Ibanez JC (1997) *Environmental electrochemistry, fundamentals and applications in pollution abatement*. Academic Press, San Diego; [ii] Murugananthan M, Raju GB, Prabhakar S (2004) *Sep Purif Technol* 40:69; [iii] Ge J, Qu J, Lei P, Liu P (2004) *Sep Purif Technol* 36:33

LMA

Electroforming — A galvanic process based on the \rightarrow *electrodeposition* of metal in a previously prepared mold. Electroforming enables the fabrication of products that have intricate shapes including either the

shapes that would otherwise be die-locked or shapes that require parting lines, varied or critical surface texture, or close tolerances. The process demands high-speed electrolytes which produce materials with low internal stresses. After the deposition of a metal layer of the desired thickness, the electroformed part is separated from the mold. This process allows perfect duplication of the master object and therefore permits mass production, at low unit cost, with a high repeatability and an excellent process control. Prominent applications of electroforming are the production of masters in the music industry, nickel stampers for CD and DVD replication, and the \rightarrow *LIGA* process.

See also \rightarrow *electrochemical machining*.

Refs.: [i] Kanani N (2004) *Electroplating: basic principles, processes and practice*. Elsevier, New York; [ii] Newman LS, Newman JH (1979) *Electroplating and electroforming for artists and craftsmen*, by Lee Scott and Jay Hartley. Crown Publishers, New York

AB, MD

Electrogenerated chemiluminescence (ECL) — (\rightarrow *electrochemiluminescence* or electrochemically generated chemiluminescence) The generation of light in an electrochemical cell by an energetic electron transfer reaction, often between radical ions in an aprotic solvent. In a typical experiment in a solution of rubrene (R) and *N,N,N',N'*-tetramethyl-*p*-phenylenediamine (TMPD) in dimethylformamide initially radical anions of rubrene are formed by electroreduction

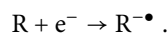

After stepping the potential to a sufficiently positive value electrooxidation of TMPD to the radical cation occurs



The electron transfer (“radical annihilation”) reaction of the ion radicals yields rubrene molecules in their triplet state

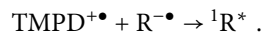

Triplet–triplet annihilation then yields the excited singlet state of rubrene



Radiative relaxation of this molecule to its ground state causes the emission of yellow light

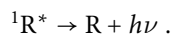

ECL can also be generated in aqueous solutions through the use of a \rightarrow *coreactant* (next subentry). For example, the simultaneous oxidation of Ru(bpy)₃²⁺ and oxalate or tri-*n*-propylamine leads to the production of the excited state of Ru(bpy)₃²⁺ and subsequent emission.

Refs.: [i] Bard AJ (ed) (2004) *Electrogenerated chemiluminescence*, Marcel Dekker, New York [ii] Bard AJ, Faulkner LR (2001) *Electrochemical methods*, 2nd edn. Wiley, New York, p 736; [iii] Bocarsly AB, Tachikawa H, Faulkner LR (1996) *Photonic electrochemistry*. In: Kissinger PT, Heineman WR (eds) *Laboratory techniques in electroanalytical chemistry*, 2nd edn. Marcel Dekker, New York

Coreactant (ECL) — A coreactant in \rightarrow *electrochemiluminescence (ECL)* is a species that generates an intermediate on oxidation that is a strong reductant (e.g., oxalate or tri-*n*-propylamine) that can react with the precursor oxidized form (e.g., Ru(bpy)₃³⁺) to form an excited state. Similarly, a species that generates a strong oxidant on reduction (like peroxydisulfate that generates SO₄^{•-}) is a coreactant for precursor-reduced species (e.g., a radical anion) to generate light. The use of a coreactant allows ECL to be generated in a single oxidative or reductive step.

Ref.: [i] Bard AJ, (2004) *Electrogenerated chemiluminescence*. Marcel Dekker, New York pp 213

Estimation of triplet energies by ECL — A special mechanism of electrogenerated chemiluminescence used for \rightarrow *proof of highly unstable radical intermediates* (next subentry) can be utilized also for estimation of triplet energies.

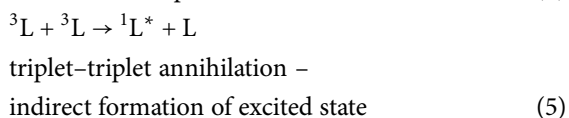
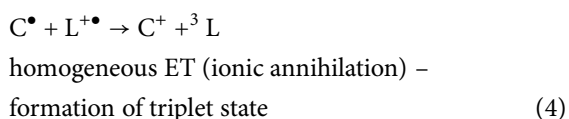
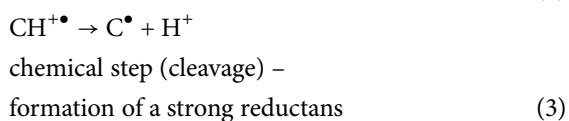
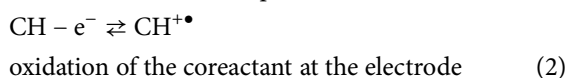

Observation of a light emission points to the fact that the energetic criterion necessary for the triplet state formation is evidently fulfilled

$$E^{\text{ox}}(\text{donor}) - E^{\text{red}}(\text{acceptor}) - T\Delta S > E_T(L) , \quad (7)$$

(where E_T is triplet energy and $T\Delta S = 0.1$ eV). For the estimation of E_T we are looking for the extreme case when

$$E^{\text{ox}}(\text{donor}) - E^{\text{red}}(\text{acceptor}) - T\Delta S = E_T(L) . \quad (8)$$

L is the compound with the unknown E_T and CH is a coreactant. A series of compounds A with reversible reduction potentials $E^{\text{red}}(A) \geq E^{\text{ox}}(C^\bullet)$ is added in stepwise experiments to the L/CH system where new reactions appear:

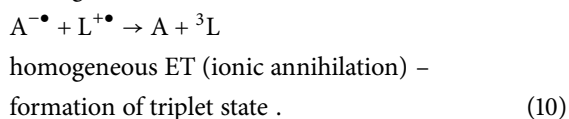

From a plot of ECL intensity (I_{ECL}) as a function of $E^{\text{ox}}(L) - E^{\text{red}}(A)$ the triplet energy is obtained as a potential difference critical for the emission according to Eq. (8). The radical ion annihilation reaction in ECL can lead directly to either singlet (S) or triplet (T) species, depending on the energy of the electron transfer reaction and the excited states produced. When the reaction enthalpy is large enough to produce the singlet state, this is called an “energy sufficient” or S-route reaction. When it can only produce the triplet state, it is called an “energy deficient” or T-route reaction. These conditions are useful in using the presence of ECL emission to find triplet energies of luminophores.

Ref.: [i] Ludvík J, Pragst E, Volke J (1984) *J Electroanal Chem* 180:141; [ii] Bard AJ (ed) (2004) *Electrogenerated chemiluminescence*. Dekker, New York, p 19, p 163

Proof of highly unstable radical intermediates by electrochemiluminescence — A special mechanism of \rightarrow *Electrochemiluminescence* is observed when both reacting species of the electron transfer are generated simultaneously at the same potential at the same electrode (so-called DC-ECL or ECL with a coreactant). This is possible only when a chemical step is involved in the electrode process of the coreactant (CH). A typical example is the cleavage of its primarily formed ion radical into a stable ion and a strongly reducing or oxidizing

radical which immediately reacts with the present radical ion of the luminescent compound L:

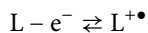

oxidation of the luminophore at the electrode (11)

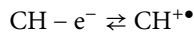

oxidation of the coreactant at the electrode (12)

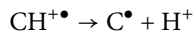

chemical step (cleavage) –

formation of a strong reductant (13)

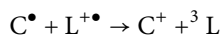

homogeneous ET (ionic annihilation) –

formation of triplet state (14)

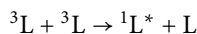

triplet–triplet annihilation –

indirect formation of excited state (15)

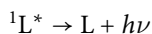

light emission – ECL . (16)

The observation of an emission of light is unambiguous proof of the existence of the unstable radical intermediate C^{\bullet} in the electrooxidation mechanism. In this way, various radical intermediates were proved and mechanisms estimated (e.g., anodic oxidation of NADH [i]).

Ref.: [i] Ludvík J, Volke J (1988) *Anal Chim Acta* 209:69; [ii] Lai RY, Bard AJ (2003) *J Phys Chem A* 107:3335

Visualization of electrode processes by electrochemiluminescence — The method of \rightarrow *electrochemiluminescence* can be used for visualization of electrode processes connected with the generation of excited states. Photographing or videorecording of the observed emission offers information about the space- or time-distribution of the redox reactions at the electrode, about the efficiency of transport of the reacting species to or from the electrode, about the kinetics of the chemical steps within the reaction scheme of electrochemiluminescence and thus about the ECL mechanism itself. In this way ECL on a mercury drop was recorded [i] or photographs of ECL at a platinum \rightarrow *rotating disc electrode* enabled to follow nonhomogeneous distribution of light intensity which changes with the distance from the center of rotation and depends on the type of process and on the rotation speed [ii, iii]. Along with the transport phenomena is connected observation of a so-called “edge effect” [iv]; on the other hand, by ECL one can investigate the morphology of the electrode surface and search for nonhomogeneities in the electrode material [v, vi].

Ref.: [i] Pragst F, von Löwis M (1982) *J Electroanal Chem* 133:173; [ii] Ludvík J, Volke J (1990) *Electrochim Acta* 35:1983; [iii] Maloy JT, Prater KB, Bard AJ (1971) *JACS* 93:5959; [iv] Engstrom RC, Pharr CM, Koppang MD (1987) *J Electroanal Chem* 221:251; [v] Engstrom RC, Johnson KW, DesJarlais S (1987) *Anal Chem* 59:670; [vi] Kukoba AV, Rozhitskii NN (1993) *Elektrokhimiya* 29:261

JL

Electrography — Electrography, introduced independently by A. Glazunov and H. Fritz, is an obsolete technique for the direct electrochemical analysis of solid materials. The principle is that a solid specimen is pressed on a paper which is soaked with an electrolyte solution. By anodic oxidation of the surface of the solid specimen the reaction products (e.g., nickel(II) ions) react with a reagent in the paper (e.g., dimethylglyoxime) to give colored reaction product (red in case of nickel(II) and dimethylglyoxime). This produces a print that clearly shows the distribution of the reactive element (nickel, in our example) on the surface of the specimen.

Ref.: [i] Jirkovský R (1934) *Mikrochemie (N.F.)* 9:15:331

FS

Electrogravimetry — Electroanalytical technique which is based on an electrolytic precipitation of a metal or a compound on the surface of an electrode for the purpose of being weighed on a balance [i–ii]. Despite the fact that the electrolytic precipitation of metals at the negative pole was discovered already in 1800 by \rightarrow *Cruikshank* and shortly after became utilized by \rightarrow *Davy*, electrolytic precipitations (electrogravimetry) started only in 1864 with the experiments of \rightarrow *Oliver Wolcott Gibbs* [iii]. In contrast to \rightarrow *coulometry* the charge consumed for the precipitation is **not** measured, rather the mass of the electrode before and after the precipitation. When the precipitate has a stoichiometric composition, electrogravimetry is an absolute analytical technique that does not rely on standards. The electrolysis can be performed by controlling the current or by controlling the electrode potential, or in a simple two-electrode arrangement just controlling the cell voltage [ii]. In a modern version of electrogravimetry an \rightarrow *electrochemical quartz crystal microbalance* is used, allowing determination of the mass changes of an electrode simultaneous to any voltammetric measurements. See also \rightarrow *Böttger*, \rightarrow *Classen*, \rightarrow *coulogravimetry*, \rightarrow *coulometer*, \rightarrow *electrochemical quartz crystal microbalance*, \rightarrow *electrodesposition*, \rightarrow *Gibbs*, *Oliver Wolcott*, \rightarrow *internal electrolysis*, \rightarrow *Smith*.

Refs.: [i] Classen A, Daneel H (1927) *Quantitative Analyse durch Elektrolyse*, 7th edn. Springer, Berlin; [ii] Classen A, Hall WT (Translator)

(1913) *Quantitative analysis by electrolysis*. (Translation of the 5th German edn.) Wiley, New York; [iii] Gibbs W (1864) *Fresenius' Z anal Chem* 3:334

FS

Electroinactive species — Ions and neutral compounds that show no signal in electrochemical measurements. In this sense, \rightarrow *supporting electrolyte* ions are electroinactive at least in the \rightarrow *potential window*. However, note that whether a species is electroactive or not should depend on the electrode used and measurement conditions. For example, tetramethylammonium ion is electroinactive at conventional electrodes, but electroactive at the \rightarrow *interface between two immiscible electrolyte solutions*, where it gives a voltammetric wave for transfer across the interface.

TO

Electrokinetic chromatography (EKC), or electrokinetic capillary chromatography (ECC) — An electrophoretic separation technique (\rightarrow *electrophoresis*) based on a combination of \rightarrow *electrophoresis* and interactions of the analytes with additives (e.g., \rightarrow *surfactants*), which form a dispersed phase moving at a different velocity. In order to be separated either the analytes or this secondary phase should be charged.

Ref.: [i] Riekkola ML, Jönsson JÅ, Smith RM (2004) *Pure Appl Chem* 76:443

WK

Electrokinetic effects — A number of effects caused by the asymmetric distribution of charged particles in the electrochemical \rightarrow *double layer* and subsequent charge separation during relative motion of liquid and solid phase. They can occur when the diffuse double layer is thicker than the hydrodynamic boundary layer.

In \rightarrow *electrophoresis* a potential difference may cause a flow of charged particles (ions, colloidal particles) in

a stagnant liquid. A flow of liquid is caused by the potential difference in \rightarrow *electroosmosis*. Movement of charged particles in a stagnant solution (e.g., sedimentation) may cause a potential (\rightarrow *sedimentation potential*). A flow of liquid through a capillary may cause a \rightarrow *streaming potential*. Electrokinetic effects can be treated using phenomenological equations and the \rightarrow *Onsager relations* based on nonequilibrium thermodynamics.

Ref.: [i] Hunter RJ (2001) *Foundations of colloid science*. Oxford University Press, Oxford

RH

Electrokinetic energy conversion — The existence of \rightarrow *electrokinetic effects* allows the conversion of mechanical to electric energy and vice versa. Thus, it is possible to generate a potential drop across a capillary by pumping an electrolyte solution through it, which causes a current to flow around an electric circuit connecting the terminal electrodes. The process can also be reversed by applying a potential difference across a capillary, which forces the electrolyte solution to flow. The thermodynamic efficiency of both modes has been investigated [i].

Ref.: [i] Xiangchun Xuan, Dongqing Li (2006) *J Power Sources* 156:677

FS

Electrokinetic phenomena \rightarrow *electrokinetic effects*

Electrokinetic potential \rightarrow *zeta potential*

Electrokinetic remediation \rightarrow *electroremediation*

Electrokinetic sonic amplitude (ESA) effect \rightarrow *electroacoustics*

Electroless plating — An autocatalytic process of metal deposition on a substrate by reduction of metal ions from solution without using an external source of electrons. It is promoted by specific reductants, namely formaldehyde, sodium hypophosphite, sodium borohydride, dialkylamine borane, and hydrazine. Electroless deposition has been used to produce different metal (e.g., nickel, cobalt, copper, gold, platinum, palladium, silver) and alloy coatings. It can be applied to any type of substrate including non-conductors. Some substrates are intrinsic catalytic for the electroless deposition; other can be catalyzed usually by sensibilization followed by Pd nucleation; also, in some non-catalytic metallic substrates the electroless process can be induced by an initial application of an appropriate potential pulse. In practical terms, the evaluation of the catalytic activity of a substrate for the electroless deposition of a given metal is

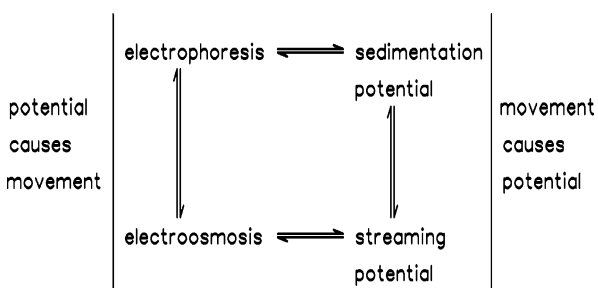

Electrokinetic effects — Figure

carried out by the measurement of the so-called mixed \rightarrow *potential* evolution with time and the lapse required to attain the deposition potential. Once the process is initiated, the deposited metal must itself be catalytic for the plating to continue.

E

In comparison with electrodeposition, electroless plating provides more uniform and less porous coatings. Furthermore, the electrolessly prepared deposits present unique physical and chemical properties, such as hardness and \rightarrow *corrosion* resistance. For those characteristics, the coating content in the non-metallic element provided by the reducing agent appears as determinant. This is the case for the first and more often applied process: nickel plating from hypophosphite ion-containing solutions, forms Ni–P alloys with 3 to 35 P atom percent (a/o), depending on the experimental conditions (solution composition and pH).

In hypophosphite-based baths the involved reactions are

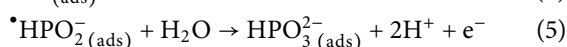
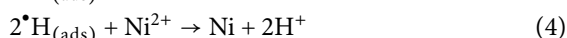
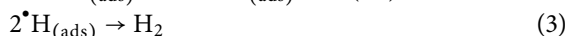
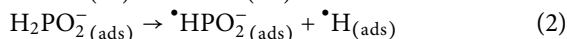
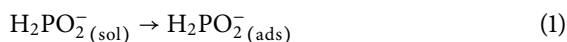

Equations (1) to (3) explain the occurrence of hydrogen evolution over the substrate. The presence of phosphorus is a result of the reaction between hypophosphorous acid with a hydrogen radical, according to

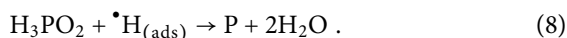

Electroless plating should not be confused neither with the electrochemical (galvanic) displacement deposition – process involving the oxidation (dissolution) of the metallic substrate and concomitant reduction of metallic ions in solution – nor with the homogeneous chemical reduction process – indiscriminate deposition over all objects in contact with the solution.

Refs.: [i] Brenner A, Riddell G (1946) *J Res Nat Bur Stand* 37:31; [ii] Pearlstein F (1965) *Electroless plating*. In: Lowenheim (ed) *Modern electroplating*. Wiley, pp 710–747; [iii] Abrantes LM, Correia J (1994) *J Electrochem Soc* 141:2356

LMA

Electroluminescence — The emission of light from a solid, usually a \rightarrow *semiconductor*, by passage of an elec-

tric current [i–iii]. The light is often the result of an annihilation reaction between the electrically-injected electrons and holes (sometimes called injection electroluminescence). Electroluminescence can be generated in electrochemical cells with a semiconductor electrode, where the solution phase is one contact. For example, an electrode of ZnS doped with Mn, when used as a cathode in a solution containing peroxydisulfate, will show fairly intense emission caused by hole injection by the $\text{SO}_4^{\bullet-}$ radicals reacting with electrons in the ZnS:Mn [iv]. See also \rightarrow *electrogenerated electroluminescence*.

Refs.: [i] Ivey F (1963) *Electroluminescence and related effects*. Academic Press, New York; [ii] Miyata S, Nalwa HS (eds) (1997) *Organic electroluminescent materials and devices*. Gordon and Breach, Amsterdam; [iii] Bard AJ (ed) (2004) *Electrogenerated chemiluminescence*. Marcel Dekker, New York, p 21; [iv] Ouyang J, Fan FRF, Bard AJ (1989) *J Electrochem Soc* 136:1033

AJB

Electrolysis — (Greek: *...lysis* – splitting) Decomposition of a material by application of an electrical voltage resulting in a flow of electric current associated with electroreduction at a cathode and electrooxidation at an anode.

RH

Electrolysis cell (electrolytic cell) — An electrolysis cell typically consists of an inert vessel containing a supporting \rightarrow *electrolyte* solution, a reactant, an \rightarrow *anode* and a \rightarrow *cathode*, and a \rightarrow *separator*. The reactant is typically unreactive at the \rightarrow *open-circuit potential* of the cell, but becomes reactive upon application of an \rightarrow *overpotential* to either the anode or the cathode (or both). In general there is sufficient volume inside the cell to contain the product formed, which is removed on a batch basis. (*cf.* a flow cell, in which the product is collected elsewhere.) At constant temperature and pressure, the \rightarrow *Gibbs energy* of the electrolysis reaction is positive, which means that energy must be supplied from the surroundings to make the reaction proceed. This contrasts with reactions inside a \rightarrow *galvanic cell*, for which the Gibbs energy is negative, and which therefore proceed spontaneously.

SF

Electrolyte — Compounds that dissociate (\rightarrow *dissociation*) into \rightarrow *ions* upon dissolution in \rightarrow *solvents* or/and upon melting and which provide by this the \rightarrow *ionic conductivity*. Also, compounds that possess in the solid state a rather high ionic conductivity are called \rightarrow *solid electrolytes*. \rightarrow *True electrolytes* are those which are build up of ions in the solid state (or pure form), whereas \rightarrow *potential electrolytes* are those which form ions only

upon dissolution and dissociation in solvents (they exist as more or less covalent compounds in the pure state). Good electrolytes are electronic \rightarrow *insulators*.

Electrolytes are used in electrochemistry to ensure the current passage in \rightarrow *electrochemical cells*. In many cases the electrolyte itself is \rightarrow *electroactive*, e.g., in copper refining, the copper(II) sulfate solution provides the ionic conductivity and the copper(II) ions are reduced at the \rightarrow *cathode* simultaneous to a copper dissolution at the \rightarrow *anode*. In other cases of \rightarrow *electrosynthesis* or \rightarrow *electroanalysis*, or in case of \rightarrow *sensors*, electrolytes have to be added or interfaces between the electrodes, as, e.g., in case of the \rightarrow *Lambda probe*, a high-temperature solid electrolyte.

Ref.: [i] Koryta J, Dvorak J (1987) *Principles of electrochemistry*. Wiley, Chichester

ŠKL

aqueous electrolyte — Aqueous electrolytes are solutions of dissociated salts, acids, or bases in \rightarrow *water*, which is an amphiprotic ($K_{AP} = 1.00 \times 10^{-14}$) and polar ($\epsilon_r = 80.20$ at 20°C) substance. Water is a very good solvent for many inorganic compounds. Commonly used aqueous \rightarrow *supporting electrolytes* are solutions of KCl, KNO_3 , K_2SO_4 , NaCl, NaClO_4 , NaNO_3 , NH_4Cl , HCl, HClO_4 , H_2SO_4 , HNO_3 , KOH, NaOH, NH_3 and borate, citrate, phosphate, and acetate \rightarrow *buffers*. They are prepared with either double-distilled, or deionized water with the specific resistance of $18.2 \text{ M}\Omega \text{ cm}$.

Ref.: [i] Dahmen EAMF (1986) *Electroanalysis*. Elsevier, Amsterdam

ŠKL

indifferent electrolyte \rightarrow *supporting electrolyte*

nonaqueous electrolyte — Common \rightarrow *solvents* for nonaqueous electrolytes are alcohols, acids, amines, ethers, nitriles, amides, dimethyl sulfoxide, and methylene chloride. The first two groups of compounds are amphiprotic, amines are protophilic, and the others are aprotic solvents. They are used for the investigation of electrochemical properties of organic compounds, but this is not a general rule. Some examples are given below [i].

- Methanol (autoprotolysis constant $K_{AP} = 2.0 \times 10^{-17}$, dielectric constant $\epsilon_r = 32.6$ at 20°C): commonly used \rightarrow *supporting electrolytes* are inorganic salts and bases and tetraalkylammonium salts (TAAX). Recommended \rightarrow *reference electrode*: $\text{Ag}/\text{AgCl}(\text{s})$, LiCl sat. in the solvent ($E = 0.143 \text{ V}$ vs. SHE) [ii].
- Acetic acid ($K_{AP} = 3.5 \times 10^{-15}$, $\epsilon_r = 6.15$ at 20°C): electrolytes are inorganic salts and acids. Reference:

$\text{Ag}/\text{AgCl}(\text{s})$, $1 \text{ mol L}^{-1} \text{ LiClO}_4$ in the solvent ($E = 0.350 \text{ V}$ vs. SHE) [ii].

- Pyridine ($\epsilon_r = 12.3$ at 20°C): electrolytes are inorganic salts and TAAX. Reference: $\text{Ag}/1 \text{ mol L}^{-1} \text{ AgNO}_3$ in the solvent ($E = 0.09 \text{ V}$ vs. SCE aq.) [iii].
- Tetrahydrofuran ($\epsilon_r = 7.6$ at 20°C): electrolytes are LiClO_4 , NaClO_4 , and TAAClO_4 . Reference: $\text{Ag}/\text{AgNO}_3(\text{s})$, $0.1 \text{ mol L}^{-1} \text{ TAAClO}_4$ in the solvent ($E = 0.627 \text{ V}$ vs. SCE aq.) [iv].
- Acetonitrile ($\epsilon_r = 37.5$ at 20°C): electrolytes are LiClO_4 , NaClO_4 , TAAX, and mineral acids. Reference: $\text{Ag}/0.1 \text{ mol L}^{-1} \text{ AgNO}_3/0.1 \text{ mol L}^{-1} \text{ NaClO}_4$ in the solvent ($E = 0.3 \text{ V}$ vs. SCE aq.) [i].
- Dimethylformamide ($\epsilon_r = 36.7$ at 20°C): electrolytes are NaClO_4 and TAAX. Reference: $\text{CdHg}(\text{s})/\text{CdCl}_2(\text{s})$, $\text{CdCl}_2 \times \text{H}_2\text{O}(\text{s})$, $\text{NaCl}(\text{s})$ /the solvent [v, vi].
- Dimethyl sulfoxide ($\epsilon_r = 47$ at 20°C): electrolytes are NaClO_4 , LiCl, NaNO_3 , KClO_4 , and TAAClO_4 . Reference: $\text{Ag}/\text{AgCl}(\text{s})$, $\text{KCl}(\text{s})$ /the solvent ($E = 0.3 \text{ V}$ vs. SCE aq.) [i, vi].

Refs.: [i] Mann CK (1969) *Nonaqueous solvents for electrochemical use*. In: Bard AJ (ed) *Electroanalytical chemistry*, vol. 3. Marcel Dekker, New York, p 57; [ii] Tinner U (1989) *Elektroden in der Potentiometrie*. Metrohm, Herisau, p 16; [iii] Cisak A, Elving PJ (1963) *J Electrochem Soc* 110:160; [iv] Hoffmann AK, Hodgson WG, Maricle DL, Jura HW (1964) *J Am Chem Soc* 86:631; [v] Marple LW (1967) *Anal Chem* 39:844; [vi] Lund H (1983) *Practical problems in electrolysis*. In: Baizer MM, Lund H (eds) *Organic electrochemistry*. Marcel Dekker, New York, p 192

ŠKL

potential electrolyte \rightarrow *weak electrolytes*

solid electrolyte \rightarrow *solid electrolytes*

strong electrolyte — Strong electrolytes are completely \rightarrow *dissociated* in a certain \rightarrow *solvent*. In \rightarrow *water* they include all salts and strong acids and bases. Weak electrolytes are only partly dissociated. In water they include almost all organic acids and bases. The classification of \rightarrow *potential electrolytes* into strong and weak acids, or bases depends on the solvent. Perchloric acid is a strong electrolyte in water and a weak electrolyte in acetic acid.

Ref.: [i] Brady JE, Holm JH (1988) *Fundamentals of chemistry*. Wiley, New York

ŠKL

supporting electrolyte — This is an electrolyte the \rightarrow *ions* of which are \rightarrow *electroinactive* in the range of applied \rightarrow *potential* being studied, and whose \rightarrow *ionic*

strength (and, therefore, contribution to the overall \rightarrow conductivity) is usually much larger than the concentration of an \rightarrow electroactive substance to be dissolved in. The concentration of supporting electrolyte varies between 0.1 and 1 mol L⁻¹. It serves to minimize the solution \rightarrow resistance and the corresponding potential drop, as well as the \rightarrow migration of the electroactive ions. The supporting electrolyte assures that the potential drop is confined to the double-layer region, thus eliminating migration. The reagents used for the preparation of the supporting electrolytes should be as pure as possible. \rightarrow Anions of the supporting electrolytes may form \rightarrow complexes with the dissolved, electroactive metal ions changing their \rightarrow half-wave and \rightarrow peak potentials in \rightarrow polarography and \rightarrow voltammetry. For the list of useful supporting electrolytes in \rightarrow water and organic solvents see the entries on \rightarrow aqueous and \rightarrow nonaqueous electrolytes.

Refs.: [i] Inczedy J, Lengyel T, Ure AM (1998) *Compendium of analytical nomenclature (IUPAC definitive rules, "The Orange Book")*, 3rd edn. Blackwell Science, Oxford; [ii] Newman J, Thomas-Alyea KE (2004) *Electrochemical Systems*, 3rd edn. Wiley Interscience, Hoboken, pp 280

ŠKL

true electrolyte — True electrolytes are compounds that in the pure solid state appear as ionic crystals. When melted, true electrolytes in pure liquid form are ionic conductors. When dissolved in polar solvents, true electrolytes are completely dissociated (see \rightarrow strong electrolytes). All salts belong to this class.

Ref.: [i] Moeller T, O'Connor R (1972) *Ions in aqueous systems*. McGraw-Hill, New York

ŠKL

weak (or potential) electrolyte — Potential electrolytes show little \rightarrow conductivity in the pure state. They consist of separate neutral molecules and the bonding of the atoms in these molecules is essentially covalent. They form ions by acid–base reaction with amphiprotic \rightarrow solvents. With \rightarrow water the potential electrolytes may react either as acids ($\text{HA} + \text{H}_2\text{O} \rightleftharpoons \text{A}^- + \text{H}_3\text{O}^+$), or as bases ($\text{B} + \text{H}_2\text{O} \rightleftharpoons \text{HB}^+ + \text{OH}^-$). These reactions proceed in two steps: ionization ($\text{HA} + \text{H}_2\text{O} \rightleftharpoons \text{A}^- + \text{H}_3\text{O}^+$) and dissociation ($\text{A}^- + \text{H}_3\text{O}^+ \rightleftharpoons \text{A}^- + \text{H}_2\text{O} + \text{H}^+$). The second step depends on the \rightarrow permittivity of the solvent. The electrolyte is \rightarrow strong if it is completely dissociated in a certain solvent, and weak if it is only partly dissociated in this solvent. In aprotic solvents the potential electrolytes can be dissolved, but neither ionized, nor dissociated.

Refs.: [i] Antropov LI (1972) *Theoretical electrochemistry*. Mir, Moscow; [ii] Newman J, Thomas-Alyea KE (2004) *Electrochemical systems*, 3rd edn. Wiley Interscience, Hoboken, pp 119

ŠKL

Electrolyte junction — A liquid junction is the region of contact of two different \rightarrow electrolyte solutions kept apart by a porous \rightarrow diaphragm, such as sintered glass or ceramic. At the contact a \rightarrow Galvani potential difference appears, which is called \rightarrow liquid junction potential (E_j). In the case of two solutions of the same electrolyte, but with different concentrations ($c(\alpha)$ and $c(\beta)$), the potential E_j is defined by the equation: $E_j = (t_+ - t_-) \frac{RT}{F} \ln \frac{c(\alpha)}{c(\beta)}$, where t_+ and t_- are \rightarrow transport numbers of the \rightarrow cation and \rightarrow anion, respectively. If the concentration of one of the ions is the same in both solutions, but the other ion differs (e.g., NaCl and KCl), the potential E_j is given by the \rightarrow Henderson equation, which is reduced to the Lewis–Sargent relation for a 1:1 electrolyte: $E_j = \pm \frac{RT}{F} \ln \frac{\Lambda(\beta)}{\Lambda(\alpha)}$, where $\Lambda(\beta)$ and $\Lambda(\alpha)$ are molar \rightarrow conductivities of the electrolytes in the compartments β and α , respectively, and the positive sign corresponds to a common cation and the negative sign to a common anion. The liquid junction potential can be minimized by a \rightarrow salt bridge in which the ions have almost equal transport numbers (e.g., KCl or KNO₃). See also \rightarrow flowing junction, and \rightarrow MacInnes.

For the potential difference at the interface of two immiscible liquids see \rightarrow Interface between two immiscible electrolyte solutions.

Ref.: [i] Hamann CH, Hamnett A, Vielstich W (1998) *Electrochemistry*. Wiley-VCH, Weinheim

ŠKL

Electrolytic capacitor — (H.O. Siegmund 1921) Capacitor with a large specific capacity based on specific properties of electrochemical interfaces. The \rightarrow capacity C of a condensator (\rightarrow capacitor) is defined as

$$C = \frac{Q}{\Delta E}$$

depends on the surface area of the plates A , the distance or thickness of the medium between the plates d , and the dielectric properties of the medium in between given by ϵ according to

$$C = \epsilon \frac{A}{d} .$$

An increase of the capacity C as desirable in numerous applications in particular in electronics can be achieved by decreasing the distance, increasing the surface area, and using dielectric media as separators in between with particularly large values of ϵ . For various technical reasons as well as economic considerations there are practical limits. An increase of the surface area can be achieved

most easily by using a rough surface of, e.g., anodized (\rightarrow *anodization*) aluminum which shows a true surface area (see \rightarrow *electrode surface area*) several times the geometric surface area of the foil used as a starting material. The insulating surface layer of Al_2O_3 formed during the anodization process on the aluminum surface serves as a dielectric, its small thickness contributes to the high capacity of the resulting device. Depending on the desired maximum voltage permitted for a condensator the thickness may vary, higher voltages require thicker dielectric layers. During production of electrolytic capacitors the aluminum foil (about 100 μm thickness, with rectangular grain structure in the rolled foil supporting the formation of vertical tunnels to grow into the aluminum subsequently during etching) to be used later as anode is etched to provide an extended \rightarrow *true electrode surface area*. Subsequently, \rightarrow *anodization* of the foil provides the required oxide layer used as dielectric (formation process). A second aluminum foil used as cathode is also etched to provide a large surface area. A separator (mostly paper) later soaked with the electrolyte solution is used. The foil-paper-foil assembly is wrapped into a coil, soaked with electrolyte solution (mostly organic solvents with soluble salts) under vacuum. Finally, the completed (packaged, sealed) capacitors are slowly brought up to maximum-rated operating voltage and temperature (aging process) providing time for formation of further oxide layers at edges, cracks formed during the winding operation, etc. A safety valve (e.g., a rubber plug or a die-set slit impression in the can wall) allows leaking of the electrolyte solution in case of overheating after abuse, polarity reversal, etc. The polarized construction allows use with DC voltages only. For AC applications two capacitors may be connected in series. Alternatively, a capacitor can be manufactured from two “anode foils” resulting in a so-called “bipolar electrolytic capacitor”.

Refs.: [i] Delnick FM, Tomkiewicz M (eds) (1996) *Electrochemical capacitors – Proceedings vol 95–29*. The Electrochemical Society, Pennington; [ii] Conway BE (1999) *Electrochemical supercapacitors: Scientific fundamentals and technological applications*. Springer, New York

RH

Electrolytic cell \rightarrow *electrolysis cell*

Electrolytic domain — describes the range of external conditions (\rightarrow *activity* of components, temperature or pressure), where the ion \rightarrow *transport number* of a material is equal to or higher than 0.99 and the material is considered as \rightarrow *solid electrolyte*. Usually this term is related to thermodynamic \rightarrow *equilibrium*.

For a given solid electrolyte under isobaric conditions, the electrolytic domain boundaries are typically analyzed as function of temperature and activity of the potential-determining component, such as gaseous O_2 for oxygen ion-conducting materials (see \rightarrow *BIMEVOX*, \rightarrow *bismuth oxide*, \rightarrow *cerium dioxide*, and \rightarrow *stabilized zirconia*). These boundaries may correspond either to phase decomposition, or to the situation when *p*- or *n*-type electronic conductivity becomes equal to 1% of total conductivity. In the latter cases, the boundaries are denoted as a_+ and a_- , respectively. When the activity of potential-determining component is higher or lower with respect to the corresponding boundaries, the intercalation or de-intercalation processes result in the electron \rightarrow *transference numbers* higher than 0.01. In these conditions, the material is not longer considered as solid electrolyte, becoming a mixed ionic–electronic conductor. Such a situation should preferably be avoided in \rightarrow *fuel cells*, \rightarrow *batteries*, and potentiometric \rightarrow *sensors* due to \rightarrow *electrolytic permeability* and deviations from \rightarrow *Nernst equation* (see also \rightarrow *Wagner equation*).

Refs.: [i] Rickert H (1982) *Electrochemistry of solids. An introduction*. Springer, Berlin; [ii] Schmalzried H (1963) *Z phys Chem* 38:87

VK

Electrolytic permeability — of ion-conducting \rightarrow *solid materials* is the transport of neutral potential-determining component(s) under a \rightarrow *chemical potential* gradient due to the presence of bulk electronic conductivity in the material, or a parameter describing this transport. As the flux of ions is charge-compensated by a simultaneous flux of electronic charge carriers, \rightarrow *steady-state* permeation can be achieved without external circuitry. The transport processes can be quantitatively described in terms of \rightarrow *ambipolar conductivity*.

The overall permeation rate of a material is determined by both ambipolar conductivity in the bulk and interfacial exchange kinetics. For \rightarrow *solid electrolytes* where the electron \rightarrow *transference numbers* are low (see \rightarrow *electrolytic domain*), the ambipolar diffusion and permeability are often limited by electronic transport.

The electrolytic permeability is a property of any solid electrolyte, since a local equilibrium involving ions and electrons is required by \rightarrow *thermodynamics* for any conditions close to steady-state or global equilibrium. However, it is possible to optimize the level of permeability, depending on particular applications. In many cases, the permeability is a parasitic phenomenon leading to power losses in \rightarrow *fuel cells* and \rightarrow *batteries*, lower efficiency of solid-state \rightarrow *electrolyzers* and \rightarrow *electrochemi-*

cal gas compressors, and poor accuracy of potentiometric → sensors. On the contrary, this phenomenon is useful for applications where fast transport of a component through, in, or from a solid material is desirable. These include, in particular, dense mixed-conducting membranes for gas separation and partial oxidation of hydrocarbons, → electrodes of various solid-state devices, catalyst supports, and mixed-conducting materials for → oxygen and → hydrogen storage.

Refs.: [i] Rickert H (1982) *Electrochemistry of solids. An introduction*. Springer, Berlin; [ii] Schmalzried H (1963) *Z phys Chem* 38:87; [iii] Bouwmeester HJM, Burggraaf AJ (1996) *Dense ceramic membranes for oxygen separation*. In: Burggraaf AJ, Cot L (eds) *Fundamentals of inorganic membrane science and technology*. Elsevier, Amsterdam, pp 435–528

VK

Electrolytic process — Electrochemical process at two electrodes forced by application of a potential from an external voltage source. The → anode is thus charged positively to serve as an electron acceptor where the substrate can be oxidized. The → cathode is charged negatively to be a good electron donor for reduction reactions. The → faradaic current flowing through the cell reflects the extent of provoked chemical changes in the solution. These systems represent a change of electrical energy to the chemical one and are utilized, e.g., for → electrolysis, → electrosynthesis, → electrorefining of metals, → electroplating or for recharging of storage cells.

JL

Electrolyzer — Electrochemical cell used for electrolytic processes (→ electrolysis), i.e., the electrochemical decomposition of matter.

RH

Electromagnetic field — A region of space in which force can be exerted to charged particles and that is in turn affected by the presence and motion of such particles. It can be understood as a collection of two interrelated and orthogonal vectors indicating the eventual electric and magnetic forces that a suitable probe would experience at each point in that region of space. It can be generated when the velocity of a charged particle changes and can be described by → Maxwell's equations [i, ii].

Refs.: [i] Reitz J, Milford F, Christy R (1992) *Foundations of electromagnetic theory*. Addison Wesley, New York; [ii] Feynman RP, Leighton RB, Sands M (1989) *The Feynman lectures on physics, vols. I and II*. Addison-Wesley, Massachusetts

FG

Electromagnetic wave — Oscillatory propagating electromagnetic field. Maxwell's equations, for free space, can be manipulated into the form of two extremely concise vector equations, $\nabla^2 \vec{E} = \varepsilon_0 \mu_0 \frac{\partial^2 \vec{E}}{\partial t^2}$ and $\nabla^2 \vec{B} = \varepsilon_0 \mu_0 \frac{\partial^2 \vec{B}}{\partial t^2}$, where \vec{E} is the electric field, \vec{B} is the magnetic field, ε_0 is the permittivity of vacuum, and μ_0 is the permeability of vacuum. Such equations were studied before Maxwell's work and were known to describe wave phenomena. A time-varying \vec{E} -field generates a \vec{B} -field and vice-versa. Both fields are perpendicular to each other and propagate in the direction of the Poynting vector $\vec{S} = \frac{1}{\mu_0} \vec{E} \times \vec{B}$, which is simultaneously perpendicular to \vec{E} and \vec{B} , characterizing a transverse oscillation (the vector describing the energy flux has been named after John Henry Poynting, 1852–1914). Depending on the wavelength, electromagnetic waves are denominated, e.g. (from shorter to longer wavelengths) γ -rays, X-rays, ultraviolet, light, infrared, microwaves, radiofrequency.

Ref.: [i] Hecht E (1987) *Optics*. Addison-Wesley, Reading

IH

Electrometallurgy — Metal winning and refining processes based on electrochemical reactions (processes where a flow of electric current provides only heat but no electrochemical reaction are electrothermal ones).

Ref.: [i] Popov K, Djokic S, Grgur B (2002) *Fundamental aspects of electrometallurgy*. Kluwer Plenum, Boston

RH

Electromigration → migration

Electrometer — is an electrical instrument for measuring electric charges, differences of electrical potentials, or small currents. There are many types of electrometers, varying from historical [i] hand-made → electroscopes to modern electronic devices [ii, iii] based on vacuum tubes or solid-state electronics. In modern definition, electrometers are highly sensitive electronic → voltmeters with very high → input impedance allowing precise measurements of small potential differences. Vibrating reed electrometers measure alternative currents generated by a variable capacitance between vibrating charged electrodes. This current can be easily amplified allowing measurements of small charge values. A similar approach (with the use of a vibrating electrode) could be used to measure charges (and their changes) on an interface between two immiscible liquids [iv]. Valve-type electrometers use an amplifying circuit with extremely high input resistance, thus allowing measurements of

very low currents (a few femtoamperes, 10^{-15} A). Solid-state electrometers are often multipurpose devices that can measure voltage, charge, resistance, and current, and they are usually based on field-effect transistors.

Refs.: [i] Bottomley JT (1877) *Electrometers (Science lectures at South Kensington)*. Macmillan and Co; [ii] *Electrometer measurements*. (1972) Keithley Instruments; [iii] Anso MK, Roos ME, Saks OV, Shor VG, Khyammalov YA (1989) *Instrum Exp Tech* 32:1257; [iv] Volkov AG, Deamer DW (eds) (1996) *Liquid-liquid interfaces. Theory and methods*. CRC-Press, Boca Raton

EK

Electrometer amplifier — An electronic amplifier with an extremely high \rightarrow input impedance ($R_{in} > 10^{14} \Omega$). The device allows measurements of electrical voltages (potentials) at practically zero current. Early devices employed specially designed and selected vacuum tubes (electrometer tubes) operated in a mode with very low grid current. The development of field effect transistors of various types allowed the application of solid-state devices. Electrometer amplifiers are employed in \rightarrow pH meters (and generally in so-called pI meters, where I stands for 'ion'), all types of instruments for potentiometric measurements and in the reference electrode input of \rightarrow potentiostats. Because of the high input impedance electrometer amplifiers are sensitive towards electric interferences, consequently some potentiostats have their \rightarrow reference electrode input circuitry (essentially an electrometer amplifier) mounted in a separate housing to be attached as close as possible to the reference electrode in order to minimize external interference.

Refs.: [i] Barna A, Porat DI (1989) *Operational amplifiers*. Wiley, New York; [ii] Malmstadt HV, Enke CG (1963) *Electronics for scientists*. WA Benjamin, New York; [iii] Dölling R (1998) *Mater Corros* 49:535

RH

Electromotive efficiency \rightarrow glass electrode, subentry \rightarrow dissociation mechanism (mechanism of response of the glass electrode)

Electromotive force (emf) — Symbol: E , SI unit: V, abbreviation: emf. (The symbol of E_{MF} is no longer recommended for this quantity by IUPAC.)

The electromotive force is the limiting value of the \rightarrow electric potential difference of a galvanic cell when the current through the external circuit of the cell becomes zero, all local \rightarrow charge transfer equilibria across phase boundaries, except at the electrolyte – electrolyte junctions, and local chemical equilibria within phases being established.

There is an inherent link between emf and the \rightarrow potential of the \rightarrow electrochemical cell reaction (E_{cell}), however, the definition of E_{cell} is purely thermodynamic, while that of the emf is operational. In order to avoid confusion regarding the sign (+ or -) of emf (and E_{cell}) it is necessary to introduce an unambiguous convention. The \rightarrow cell diagram has to be drawn such a way that the oxidation always occurs at the left-hand-side electrode while the reduction takes place at the right-hand-side electrode, i.e., the positive electricity flows through the cell from left to right. (Therefore, the positive electricity flows from right to left through the outer part of the circuit. In this way, for a spontaneous reaction when the \rightarrow Gibbs energy change of reaction, $\Delta G < 0$, the value of emf and E_{cell} will be positive.

Refs.: [i] Mills I, Cvitas T, Homann K, Kallay N, Kuchitsu K (eds) (1993) *IUPAC quantities, units and symbols in physical chemistry*. Blackwell, Oxford, p 58, 60; [ii] Parsons R (1974) *Pure Appl Chem* 37:503; [iii] Bard AJ, Faulkner LR (2001) *Electrochemical methods*. 2nd edn. Wiley, New York, pp 49–52

GI

Electromotive loss factor \rightarrow glass electrode, subentry \rightarrow dissociation mechanism (mechanism of response of the glass electrode)

Electromotive series \rightarrow potential, and subentries \rightarrow standard potential, and \rightarrow tabulated standard potentials

Electron — The electron was the first elementary particle to be discovered, by J. J. Thomson in 1897. It has a very low rest mass m_e of $9.1093826(16) \times 10^{-31}$ kg, and an elementary charge e of $1.60217653(14) \times 10^{-19}$ C [i]. Electric charge is conserved. Thus, in chemistry, where electrons are not annihilated by other nuclear particles, we can assume that electrons themselves are conserved. (This explains why chemical reactions “have to balance”.) Electrons have two spin states. The number of spin states for any particle of non-zero rest mass is $2s + 1$, so the electron has spin quantum number $s = 1/2$. This means that electrons are fermions – their wavefunctions are antisymmetric, and they obey the exclusion principle. The exclusion principle states that two electrons in an atom are excluded from occupying the same energy level, unless they have opposite spin. Inside a substance, electrons populate energy levels according to the Fermi–Dirac function $F(E_i)$ (\rightarrow Fermi–Dirac statistics). This tells us what the probability is that a selected energy level i is occupied by an electron. (Assuming the energy level exists, and assuming the energy level lies inside a system that is in thermal equilibrium with a large reservoir of

heat). In its electrochemical form

$$F(E_i) = \frac{1}{1 + \exp\left(\frac{E_i - E_F}{kT}\right)}.$$

Here k is the \rightarrow Boltzmann constant, T is the absolute temperature, E_i is the energy of the i th energy level, and E_F is the \rightarrow Fermi energy. The Fermi energy of a system is simply the energy at which the Fermi–Dirac function equals one half. There is not necessarily an energy level that corresponds with it. For most metals, the Fermi energy lies about (4 ± 2) eV below the vacuum energy. Note that the Fermi–Dirac function is not a density-of-states. That is, it does not tell us anything about whether a particular energy level actually exists. It merely tells us what the probability of occupancy would be, if indeed the state did exist. In a \rightarrow semiconductor, which by definition has a gap in its distribution of energy levels, it often happens that no such level exists. However, in a metal, there is a nearly continuous distribution of energy levels. Thus, in a metal, it is virtually certain that a real energy level (called the \rightarrow Fermi level) will be found at the Fermi energy. The existence (or otherwise) of energy levels in a substance may be inferred from its density of states function $f(E)$. Disregarding the complications caused by d -orbitals, an approximate formula for the density of states in a metal is available from free electron theory. The result is

$$f(E) = \frac{4\pi(2m^*)^{3/2}}{\hbar^3} \sqrt{E},$$

where $f(E)$ is the number of electron states per unit volume per unit energy at energy E , and m^* is the effective mass of the electron. Note that this result is independent of the linear dimension L , or area A , of the metal, as it should be.

Wave/particle duality is the postulate that all objects of physical reality possess both localized (particle) and distributed (wave) properties. Due to their low rest mass, electrons exhibit both particle and wave behavior on the scale of length of atoms (nanometers). Thus, every electron has a wavelength associated with it. This wavelength is called the de Broglie wavelength λ_{DB} ,

$$\lambda_{\text{DB}} = \frac{h}{p}.$$

Here h is the \rightarrow Planck constant and p is the electron's momentum. For an electron traveling at nonrelativistic velocities, this can be written as

$$\lambda_{\text{DB}} = \frac{h}{mv},$$

where m is the electron mass and v is the electron velocity, or

$$\lambda_{\text{DB}} \approx \frac{1.23}{\sqrt{V}} \text{ nm}$$

which is dimensionally sound provided the voltage V is expressed in volts. Thus, for an electron accelerated through 1 volt, the de Broglie wavelength is 1.23 nm. Most importantly, the wave character of electrons allows them to pass through electrostatic potential barriers that would block classical particles [ii]. This leads to the phenomenon of electron \rightarrow tunneling at interfaces [ii, iii]. It is interesting to determine what fraction of incident electrons is actually transmitted through a potential barrier, so that they emerge on the other side. This fraction is called the transmission probability T . For a rectangular barrier of width L and height Φ , and for an electron of energy E , the result is

$$T = \left[1 + \frac{(e^{\kappa L} - e^{-\kappa L})^2}{16\varepsilon(1 - \varepsilon)} \right]^{-1},$$

where $\varepsilon = E/\Phi$, and Φ is the electron work function. Assuming the barrier is high and wide so that $\kappa L \gg 1$, this simplifies to

$$T = 16\varepsilon(1 - \varepsilon) \exp(-2\kappa L).$$

Thus the transmission probability T decays exponentially with barrier thickness L . Indeed, it decreases by a factor of ~ 10 for every 0.1 nm of barrier thickness, indicating that electron tunneling is very short range indeed.

Refs.: [i] Mohr PJ, Taylor BN (2005) *Rev Modern Phys* 77:1; [ii] Hund FH (1927) *Z Phys* 40:742, 42:93, 43:805; [iii] Fowler RH, Nordheim LW (1928) *Proc R Soc London A* 119:173

SF

Electron acceptor — (1) A substance to which an electron may be transferred: for example, 1,4-dinitrobenzene or the dication 1,1,1'-dimethyl-4,4'-bipyridylium. (2) A \rightarrow Lewis acid. This usage is discouraged.

Ref.: [i] Muller P (1994) *Pure Appl Chem* 66:1077

WK

Electron activity \rightarrow $p\varepsilon$ value

Electron affinity, E_{ea} — is the energy released when an additional electron (without excess energy) attaches itself to an atom in a gas phase to form a negatively charged ion. E_{ea} values for atoms of selected elements are shown in the Table below.

Electron affinity, E_{ea} — Table

Element	Electron affinity/(kJ mol ⁻¹)
Cl	349
F	322
O	141
H	73
N	-7
He	-21

It is generally accepted that the electron affinity is positive (electron gain is exothermic) if the energy release accompanies the electron attachment. The standard enthalpy of electron gain, $\Delta_{eg}H^\ominus$, at a temperature T , is related to the electron affinity,

$$\Delta_{eg}H^\ominus(T) = -E_{ea} - \frac{5}{2}RT.$$

The standard enthalpy of electron gain of a molecular entity X is opposite to the standard ionization enthalpy of its negative ion, $\Delta_{ion}H^\ominus(X^-)$.

$$\Delta_{eg}H^\ominus(X) = -\Delta_{ion}H^\ominus(X^-).$$

For elements, both electron affinity and \rightarrow ionization energy periodically change with atomic number. The ionization energy is usually easier to measure than the electron affinity. Therefore, numerical values of E_{ea} are determined by measuring $\Delta_{ion}H^\ominus(X^-)$.

Refs.: [i] Muller P (1994) *Pure Appl Chem* 66:1077; [ii] Atkins PW (1998) *Physical chemistry*, 6th edn. Oxford University Press, Oxford

WK

Electron attachment — The transfer of an electron to a \rightarrow molecular entity, resulting in a molecular entity of (algebraically) increased negative charge. See also \rightarrow oxidation (1), \rightarrow reduction.

Ref.: [i] Muller P (1994) *Pure Appl Chem* 66:1077

WK

Electron backscatter diffraction (EBSD) — The focused electron beam of Scanning Electron Microscopes (SEM) can be used to detect the crystallographic orientation of the top layers of a sample. The backscattered electrons (information depth: 40–70 nm at 25 kV accelerating potential, lateral resolution around 200 nm) provide characteristic diffraction patterns (Kikuchi lines) on a phosphor screen. The patterns are recorded by a CCD-camera and interpreted by software. The position of the unit cell of the sample is determined by the corresponding Euler angles. In scanning mode, the software produces a surface orientation mapping that consists of

artificial colors which can be identified from the legend. EBSD is a perfect supplement for spatially resolved electrochemical techniques such as investigations of grain or grain boundary influence.

Other names instead of EBSD are Backscatter Kikuchi Diffraction (BKD), Electron Backscatter Pattern Technique (EBSP), Orientation Imaging Microscopy (OIMTM), or Automated Crystal Orientation Mapping (ACOM). In combination with electrochemical studies only *ex situ* applications are possible.

Ref.: [i] Schwartz AJ, Kumar M, Adams BL (2000) *Electron backscatter diffraction in material science*. Kluwer Plenum, New York

MML

Electron-conductor separating oil-water (ECSOW) system

— For studying the \rightarrow electron transfer (ET) at the \rightarrow oil/water interface, the ECSOW system was devised, in which the oil and water phases are separated by an electron conductor (EC), as shown in the Figure. Specifically, the oil and water phases are linked by two metal (e.g., Pt) electrodes that are connected by an electric wire. The ET across the EC phase can be observed voltammetrically in a similar manner to the oil/water interface, i.e., by controlling the potential difference between the two phases using a four-electrode potentiostat (see \rightarrow four-electrode system). Because ion transfer (IT) across the EC phase cannot take place, the ECSOW system is useful for discrimination between ET and IT occurring at the oil/water interface.

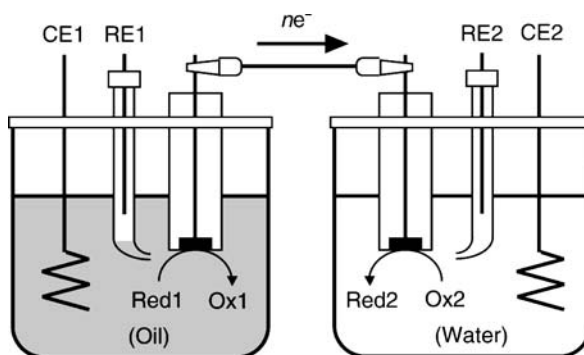

Electron-conductor separating oil-water (ECSOW) system — Figure. The ECSOW system (RE1 and RE2, reference electrodes; CE1 and CE2, counter electrodes)

Refs.: [i] Hotta H, Akagi N, Sugihara T, Ichikawa S, Osakai T (2002) *Electrochem Commun* 4:472; [ii] Hotta H, Sugihara T, Ichikawa S, Osakai T (2003) *J Phys Chem B* 107:9717

TO

Electron density — If $P(x, y, z) dx dy dz$ is the probability of finding an electron in the volume element $dx dy dz$

at the point of a molecular entity with coordinates x, y, z , then $P(x, y, z)$ is the electron density at this point. For many purposes (e.g., X-ray scattering, forces on atoms) the system behaves exactly as if the electrons were spread out into a continuously distributed charge. The term has frequently been wrongly applied to negative charge population. See also \rightarrow *charge density*.

Ref.: [i] Muller P (1994) *Pure Appl Chem* 66:1077

WK

Electron donor — (1) A \rightarrow *molecular entity* that can transfer an electron to another molecular entity, or to the corresponding \rightarrow *chemical species*. (2) A \rightarrow *Lewis base*. This usage is discouraged.

Ref.: [i] Muller P (1994) *Pure Appl Chem* 66:1077

WK

Electron-donor-acceptor complex — A term sometimes employed instead of \rightarrow *charge-transfer complex* or Lewis adduct. See also \rightarrow *quinhydrone*.

Ref.: [i] Muller P (1994) *Pure Appl Chem* 66:1077

WK

Electron hopping — is the transfer of an electron from an ion or molecule to a neighboring ion or a molecule in solution or among the redox centers of many inorganic solids (e.g., oxides). In redox or electron \rightarrow *conducting polymers* it is the main mechanism of \rightarrow *charge transfer reaction* and \rightarrow *charge transport regarding* both the intrachain and interchain electronic conduction. While this term is also used in solid-state physics, e.g., for the description of electron transport through insulating films, for chemists it is essentially an electron exchange reaction which is frequently coupled to diffusion of ions and molecules in solution or to the chain and segmental motions of the polymer (\rightarrow *Dahms-Ruff theory*). Several theories have been developed also for the long-range electron hopping [iv–vi]. For conducting polymers the Mott model of variable-range electron hopping is also considered [vii].

Refs.: [i] Erdey-Grúz T (1974) *Transport phenomena in aqueous solutions*. Adam Hilger, London, p 390; [ii] Inzelt G (1994) *Mechanism of charge transport in polymer-modified electrodes*. In: Bard AJ (ed) *Electroanalytical chemistry*, vol. 18. Marcel Dekker, p 95; [iii] Lyons MEG (1994) *Charge percolation in electroactive polymers*. In: Lyons MEG (ed) *Electroactive polymer electrochemistry*, part 1. Plenum, New York, p 1; [iv] Feldberg SW (1986) *J Electroanal Chem* 198:1; [v] Fritsch-Faulkes I, Faulkner LR (1989) *J Electroanal Chem* 263:237; [vi] Leiva E, Mayer P, Schmickler W (1988) *J Electrochem Soc* 135:1993; [vii] Heeger AJ (1989) *Faraday Discuss Chem Soc* 88:203

GI

Electron microprobe analysis (AES) \rightarrow *surface analytical methods*

Electron-pair acceptor — A synonym for \rightarrow *Lewis acid*.

Ref.: [i] Muller P (1994) *Pure Appl Chem* 66:1077

WK

Electron-pair donor — A synonym for \rightarrow *Lewis base*.

Ref.: [i] Muller P (1994) *Pure Appl Chem* 66:1077

WK

Electron mediator \rightarrow *redox mediator*

Electron spin resonance \rightarrow *spectroscopy*

Electron transfer — Electron transfer is the process by which an electron is transported into (or out of) an otherwise closed system, thereby inducing a change in the occupation number of at least one electronic state.

See \rightarrow *charge transfer reaction*, \rightarrow *electron transfer at liquid-liquid interfaces*, \rightarrow *Marcus theory*, \rightarrow *adiabatic process*, \rightarrow *non-adiabatic process*

SF

Electron transfer catalysis \rightarrow *electrocatalysis*

Electron transfer at liquid-liquid interfaces — A single \rightarrow *electron transfer* (ET) between a redox couple O1/R1 in the aqueous phase (w) and a redox couple O2/R2 in the organic solvent phase (o) can be described by the reaction scheme

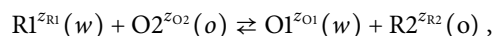

where z_i 's represent the corresponding charge numbers. At equilibrium, the equality of the \rightarrow *electrochemical potentials* of reactants and products yields the \rightarrow *Nernst equation* for the difference of inner (Galvani) electric potentials (electron transfer potential),

$$\Delta_o^w \phi = \Delta_o^w \phi_{\text{el}}^\ominus + \frac{RT}{F} \ln \frac{a_{\text{O2}}^o a_{\text{R1}}^w}{a_{\text{R2}}^o a_{\text{O1}}^w},$$

where a_i 's are the activities and $\Delta_o^w \phi_{\text{el}}^\ominus$ is the standard of \rightarrow *Galvani potential difference* (or standard electron transfer potential), which is determined by the standard Gibbs energy of ET from the phase o to the phase w , $\Delta G_{\text{tr,el}}^{\ominus,o \rightarrow w}$. The latter quantity can be related to the difference between the standard electrode potentials of O1/R1 and O2/R2, $E_{\text{O1/R1}}^{\ominus,w}$ and $E_{\text{O2/R2}}^{\ominus,o}$ vs. the standard hydrogen electrode in the phase w and o , respectively,

$$\begin{aligned} \Delta_o^w \phi_{\text{el}}^\ominus &= \frac{\Delta_o^w G_{\text{el}}^\ominus}{F} = \frac{\mu_{\text{R1}}^{\ominus,w} - \mu_{\text{O1}}^{\ominus,w} + \mu_{\text{O2}}^{\ominus,o} - \mu_{\text{R2}}^{\ominus,o}}{F} \\ &= E_{\text{O2/R2}}^{\ominus,o} - E_{\text{O1/R1}}^{\ominus,w} + \Delta_o^w \phi_{\text{H}^+}^\ominus, \end{aligned}$$

where $\Delta_o^w \phi_{H^+}^\ominus$ is the standard ion transfer for hydrogen ion transfer [i], see also \rightarrow *distribution (Nernst) potential*. The mechanism of an ET reaction involves either a single interfacial electron step, or a combination of the partition (transfer) of one reactant and the homogeneous ET reaction in one or the other solvent phase.

ET reactions at the polarizable \rightarrow *interface between two immiscible electrolyte solutions* (ITIES) have been studied by cyclic voltammetry [ii], AC impedance [iii], and scanning electrochemical microscopy (SECM) [iv]. A simple method was introduced that allows evaluation of the ET rates at the interface between the thin film of an organic solvent and the aqueous electrolyte solution [v].

The Figure shows an example of the cyclic voltammogram for the electron transfer between hexacyanoferrate(III) in water and lutetium biphthalocyanine in 1,2-dichloroethane measured at several sweep rates [vi].

From a kinetic point of view, the single electron transfer reaction is described by the second-order rate law [i],

$$J_{el} = -\frac{j}{F} = k_f c_{R1}^w(x=0) c_{O2}^o(x=0) - k_b c_{O1}^w(x=0) c_{R2}^o(x=0),$$

where J_{el} is the electron flux density in the direction $w \rightarrow o$, j is the electric current density, $c^w(x=0)$ and $c^o(x=0)$ are the reactant's concentrations on the

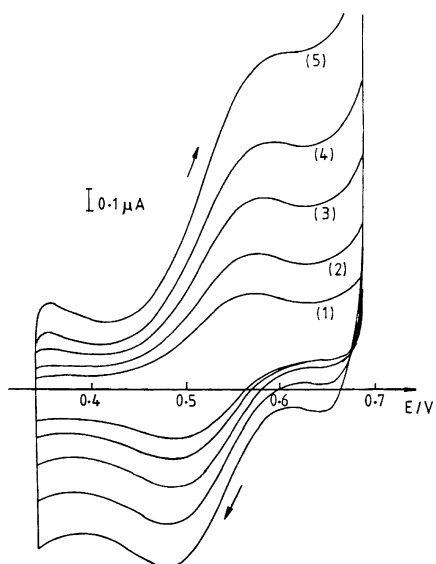

Electron transfer at liquid–liquid interfaces — Figure. Cyclic voltammograms of the interfacial electron transfer between lutetium biphthalocyanine (0.5 mM) in 1,2-dichloroethane and hexacyanoferrate(III) (0.1 M) in water at sweep rates: (1) 5; (2) 10; (3) 20; (4) 30; (5) 50 mV s^{-1} . Reprinted with permission from [iv]. © 1988 Elsevier B.V.

aqueous or the organic side of ITIES, respectively. This equation reflects the common convention that the positive electric current is associated with the transfer of a positive charge in the direction $w \rightarrow o$. As in case of the \rightarrow *ion transfer at liquid–liquid interfaces*, the heterogeneous rate constants for the forward and backward electron transfer, k_f and k_b , respectively, are related to each other by virtue of the principle of microscopic reversibility, i.e., $k_f/k_b = \exp[-F(\Delta_o^w \phi - \Delta_o^w \phi_{el}^\ominus)RT]$. Analogously, two apparent kinetic parameters can be introduced, i.e., the apparent standard rate constant $k_s' = k_f(\Delta_o^w \phi_{el}^\ominus) = k_b(\Delta_o^w \phi_{el}^\ominus)$ at the standard electron transfer potential, $\Delta_o^w \phi_{el}^\ominus$, and the apparent charge-transfer coefficient $\alpha = -(RT/F)(\partial \ln k_f / \partial \Delta_o^w \phi)$. The static double-layer effect can be accounted for by assuming an equilibrium distribution of the reactant (or products) up to the positions $x = a$ and $x = b$ located close to the interface in phases w and o , respectively, presumably at the corresponding outer Helmholtz plane (OHP) [i]. The apparent forward rate constant k_f could be then expressed by

$$k_f = k_{ft} \rho(a, b) = k_{ft} \exp[-(z_{R1} F \phi_2^w + z_{O2} F \phi_2^o) / RT],$$

where k_{ft} is the true rate constant, $\rho(a, b)$ is the probability that the redox species R1 and O2 reach the positions $x = a$ and $x = b$, respectively, between which the electron is driven by the local potential gradient to cross the interface. Assuming a sharp liquid–liquid boundary, a theoretical expression for k_{ft} was derived [vii]

$$k_{ft} = Z \exp(-\Delta G^\ddagger / RT),$$

where the pre-exponential factor Z accounts for the nonadiabaticity effect, ΔG^\ddagger is the Gibbs activation energy,

$$\Delta G^\ddagger = \frac{(\lambda + \Delta G^\ominus)^2}{4\lambda}.$$

λ is the sum of the solvent and intramolecular reorganization energies, and $\Delta G^\ominus = F(\Delta_b^a \phi - \Delta_o^w \phi_{el}^\ominus)$ is the standard electrochemical Gibbs energy of the electron transfer from $x = a$ to $x = b$. Parabolic dependence of ΔG^\ddagger on ΔG^\ominus was demonstrated [viii]. Electrochemical behavior including the kinetic analysis of various ET systems was reviewed [ix]. A special type of the ET reaction is the deposition of a metal at ITIES, e.g., the deposition of Au particles by the interfacial reaction between AuCl_4^- in 1,2-dichloroethane and $\text{Fe}(\text{CN})_6^{4-}$ in water [x].

Another approach to heterogeneous electron transfer relies on photoexcitable dye molecules adsorbed at the polarizable ITIES [xi]. General mechanism for a photoinduced electron transfer between a water-soluble dye sensitizer and a redox quencher located in the organic

phase involves the dye excitation followed by ET to quencher, in a competition with the relaxation of the excited state, the product separation, and the back electron transfer. Photocurrent responses were demonstrated for the heterogeneous quenching of the water-soluble Zn porphyrin by 7,7,8,8-tetracyanoquinodimethane in 1,2-dichloroethane in the presence and absence of hexacyanoferrate redox couple, which diminishes the back electron transfer feature [xi]. For a review of the photoinduced ET reactions see [ix].

Refs.: [i] Samec Z (1979) *J Electroanal Chem* 99:197; [ii] Samec Z, Mareček V, Weber J (1979) *J Electroanal Chem* 96:245; [iii] Chen QZ, Iwamoto K, Seno M (1991) *Electrochim Acta* 36:291; [iv] Wei C, Bard AJ, Mirkin MV (1995) *J Phys Chem* 99:16033; [v] Shi C, Anson FC (1998) *J Phys Chem B* 102:9850; [vi] Geblewicz G, Schiffrin DJ (1988) *J Electroanal Chem* 244:27; [vii] Marcus RA (1990) *J Phys Chem* 94:1050; [viii] Barker AL, Unwin PR, Amemiya S, Zhou JF, Bard AJ (1999) *J Phys Chem B* 103:7260; [ix] Fermin DJ, Lahtinen R (2001) *Dynamic aspects of heterogeneous electron-transfer reactions at liquid-liquid interfaces*. In: Volkov AG (ed) *Liquid interfaces in chemical, biological, and pharmaceutical applications*. Marcel Dekker, New York, pp 179–227; [x] Cheng Y, Schiffrin DJ (1996) *J Chem Soc Faraday Trans* 92:3865; [xi] Fermin DJ, Doung H, Ding Z, Brevet PF, Girault HH (1999) *Electrochem Commun* 1:29

ZSam

Electron transport chain (ETC) in mitochondria: The respiratory chain and oxidative phosphorylation — In eukaryotic cells, electron transport and oxidative phosphorylation occur in mitochondria. The mitochondrial ETC is often referred to as the respiratory chain, because the main step of biological \rightarrow oxidation of organic matter by oxygen occurs here. The function of the enzymes of the mitochondrial respiratory chain is to transform the energy of \rightarrow redox reactions into an electrochemical \rightarrow potential of \rightarrow proton gradient $\Delta\tilde{\mu}_{\text{H}^+}$ across the hydrophobic barrier of a coupling membrane. This gradient establishes a concentration difference of protons and can result in a difference in electrical potentials across the membrane. Proton motive force $\Delta\tilde{\mu}_{\text{H}^+}$ can be used for the phosphorylation of ADP by ATP synthase, an enzyme that can couple this energetically favorable proton flow to the synthesis of ATP. Electrons are delivered to the ETC from the reduced components of the Krebs cycle. The coupling of electron flow with the synthesis of ATP is termed oxidative phosphorylation. It is one of the most significant processes of energy conversion in biological systems. Electron flow in ETC is from reduced cosubstrates NADH and FADH₂ to molecular oxygen, which therefore becomes the ultimate oxidizing agent and which becomes reduced to H₂O in the pro-

cess. The electrons lower their chemical potential by 1.0–1.1 V when descending the respiratory chain from a substrate to oxygen. This corresponds to release of about 100 kJ of energy per mole.

Refs.: [i] Boyer P (1997) *Annu Rev Biochem* 66:717; [ii] Ksenzhek OS, Volkov AG (1998) *Plant energetics*. Academic Press, San Diego

AV

Electron work function — The electron \rightarrow work function Φ deep inside a substance is the work required to raise the energy of a stationary \rightarrow electron from the substance's \rightarrow Fermi energy to the vacuum energy [i]. In the absence of intervening electric fields, the work function also corresponds to the work required to transfer an electron from the Fermi energy inside the substance to infinity. The work function is important in the theory of thermionic emission. It is also important in the theory of metal-semiconductor junctions (Schottky diodes). This is because the difference in work function between a metal and a semiconductor determines whether their contact is ohmic or rectifying. An ohmic contact is simply one that has been prepared so that the current-voltage (I – V) curve of the interface is linear and symmetric. Ohmic contacts are formed when a metal and an n -type semiconductor are brought into ideal contact, whereas rectifying contacts are formed when

Electron work function — Table

Substance	Work function (eV)
Sodium	2.3
Potassium	2.3
Calcium	2.9
Uranium	3.6
Magnesium	3.7
Cadmium	4.1
Aluminum	4.1
Lead	4.1
Niobium	4.3
Zinc	4.3
Iron	4.5
Mercury	4.5
ITO	4.7
Copper	4.7
Silver	4.7
Carbon	4.8
Cobalt	5.0
Nickel	5.0
Gold	5.1
Platinum	6.3

a metal and a *p*-type semiconductor are brought into ideal contact. However, in the presence of surface states caused by defects etc., all contacts tend to be ohmic.

Ref.: [i] Woodruff DP, Delchar TA (1994) *Modern techniques of surface science*. Cambridge University Press, Cambridge

SF

Electronation → *electron attachment*, → *reduction*

Electronegativity — A measure of the ability of an atom or a group of atoms to attract electrons from other parts of the same → *molecular entity*. The concept has been quantified by a number of authors: See → *electronegativity according to Pauling*, → *electronegativity according to Mulliken*, → *electronegativity according to Allred–Rochow*.

Ref.: [i] Muller P (1994) *Pure Appl Chem* 66:1077; [ii] Pritchard HO, Skinner HA (1955) *Chem Rev* 55:745; [iii] Bergmann D, Hinze J (1996) *Angew Chem Int Ed* 35:150

WK

Electronegativity according to Pauling — In 1932 Linus Pauling (1901–1994) [i] introduced his → *electronegativity scale*: When a compound XX has the experimentally determined dissociation enthalpy D_{XX} and the compound YY the enthalpy D_{YY} , one can formally calculate a dissociation energy for the compound XY as follows: $D_{XY, \text{theor}} = 1/2 (D_{XX} + D_{YY})$. The value $D_{XY, \text{theor}}$ will deviate from the experimentally determined value $D_{XY, \text{exp}}$ by $\Delta D_{XY, \text{theor-exp}}$. This deviation is due to the electrons being attracted to the atoms X and Y, and the following equation can be used to give each atom the electronegativity χ (now written χ^p for ‘Pauling electronegativity’): $\chi_Y^p - \chi_X^p = \sqrt{\Delta D_{XY, \text{theor-exp}}}$. For hydrogen the value χ_H^p was taken as 2.2, and the $\Delta D_{XY, \text{theor-exp}}$ values are used in eV. Pauling electronegativities are usually given without units.

See also → *electronegativity according to Mullikan*, → *electronegativity according to Allred–Rochow*.

Refs.: [i] Pauling L (1932) *J Am Chem Soc* 54:3570; [ii] Housecroft CE, Sharpe AG (2005) *Inorganic chemistry*, 2nd edn. Pearson, UK

FS

Electronegativity according to Mulliken — In 1934, Robert S. Mulliken (1896–1986) [i, ii] introduced his → *electronegativity scale*. He defined the electronegativity of an element X (χ_X^M) as the average of the first ionization energy $E_X^{\text{ionization}}$ and electron affinity E_X^{affinity} :

$$\chi_X^M = \frac{E_X^{\text{ionization}} + E_X^{\text{affinity}}}{2}$$

The superscript M stands for Mulliken. When the ionization energy and electron affinity are expressed in MJ/mol, the Mulliken electronegativities can be expressed on the Pauling scale using the following formula:

$$\chi_X^M = 3.48 \left[\frac{E_X^{\text{ionization}} + E_X^{\text{affinity}}}{2} - 0.602 \right]$$

E

See also → *electronegativity according to Pauling*, → *electronegativity according to Allred–Rochow*.

Refs.: [i] Mulliken RS (1934) *J Chem Phys* 2:782; [ii] Mulliken RS (1935) *J Chem Phys* 3:573; [iii] Housecroft CE, Sharpe AG (2005) *Inorganic chemistry*, 2nd edn. Pearson, UK

FS

Electronegativity according to Allred–Rochow — In 1958, Allred and Rochow [i, ii] introduced their → *electronegativity scale*. They defined the electronegativity of an element X (χ_X^{AR}) as follows: $\chi_X^{\text{AR}} = \left(3590 \frac{Z_{\text{eff}}}{r_{\text{cov}}^2} \right) + 0.744$. Z_{eff} is the effective charge of the nucleus acting on the electron, and r_{cov} is the covalent radius of the atom in pm.

See also → *electronegativity according to Pauling*, → *electronegativity according to Mulliken*.

Refs.: [i] Allred AL, Rochow EG (1958) *J Inorg Nucl Chem* 5:264; [ii] Housecroft CE, Sharpe AG (2005) *Inorganic chemistry*, 2nd edn. Pearson, UK

FS

Electroneutrality condition

(i) **Macroscopic electroneutrality**: In the inner region of any phase the net charge is zero, i.e., the number of positive and negative charges must be equal. This can be mathematically formulated as follows: $F \int \sum_i z_i c_i dx = 0$, where c_i is the concentration of the *i*-th species in moles per cm³, z_i is its valence, F is the → *Faraday constant*. The (macroscopic) electroneutrality principle is a simple consequence of the thermodynamic work required to separate opposite charges, or to bring the same charges into closer contact. Substantial departures from the state of electroneutrality are limited in the time domain by the time constant, since an electric field arises which produces large conduction currents to rapidly neutralize the unbalanced charge. Similarly, in the space domain, substantial departures from neutrality may occur only over very short distances in the order of a few → *Debye lengths*.

(ii) **Microscopic electroneutrality**: The electroneutrality condition may not be fulfilled for extremely

small regions, e.g., a phase boundary (\rightarrow *double layer*) when the space limits are appropriately defined. Thus it is not fulfilled for the solution side of the double layer of an electrode, or the solvation shell of an ion. However, the electroneutrality condition will be fulfilled when the space limits are chosen so that the solution side *and* the metal side are included in the volume for which electroneutrality is assessed. A microscopic neutrality condition must be formulated as follows: $F \sum_i z_i c_i = \rho = 0$; where ρ is the charge density in coulombs per cm^3 (all other symbols with the above mentioned meaning). Note that also droplets of a liquid may have a net charge, as e.g., in electro-spray mass spectroscopy and in electrospinning of polymers.

Refs.: [i] (1997) *IUPAC compendium of chemical terminology*, 2nd edn. 66:III; [ii] Pauling L (1960) *The nature of the chemical bond*, 3rd edn. Cornell University, Ithaca, pp 172–174; [iii] Planck M (1890) *Ann Phys Chem* 39:161; [iv] Newman J, Thomas-Alyea KE (2004) *Electrochemical systems*, 3rd edn. Wiley Interscience, Hoboken, pp 286

MHer

Electronic current — The propagation of charge by electrons. Most typically, electronic currents flow in metals and semiconductors. They may accompany \rightarrow *ionic currents* in \rightarrow *solid electrolytes*, and they always accompany ionic currents in plasmas (see \rightarrow *plasma electrochemistry*).

FS

Electronic defects — in \rightarrow *solid materials* are, in a general sense, imperfections in regular electronic structure of ions or atoms with respect to an ideal lattice. The most important cases include (i) the \rightarrow *electrons* promoted into a higher energy level or a band due to thermal fluctuations or by external factors such as radiation, (ii) the electrons introduced in a crystal due to \rightarrow *doping* or equilibration with the environment, (iii) positively charged holes in the \rightarrow *valence band* which may be formed due to similar reasons, and (iv) \rightarrow *polarons* which are the combination of electrons and strain field in the surrounding lattice. The polarons are often divided into two groups, namely large and small. The electron associated with a large polaron moves in a band, whereas its effective mass is moderately enhanced. The electron associated with a small polaron is trapped on a single ion or a group of ions, and may migrate via hopping. In many cases, the energy levels formed due to doping or to presence of point defects are also considered as defects in

the electronic sublattice. For \rightarrow *solid electrolytes*, the concentration of electronic defects is the factor determining electronic conductivity and \rightarrow *electrolytic permeability*.

See also \rightarrow *semiconductors* and \rightarrow *defects in solids*.

Refs.: [i] West AR (1984) *Solid state chemistry and its applications*. Wiley, Chichester; [ii] Rickert H (1982) *Electrochemistry of solids. An introduction*. Springer, Berlin

VK

Electronic effect of substituents: symbols and signs —

The \rightarrow *inductive effect* has universally been represented by the symbol *I*. This is now commonly taken to include both through-bonds and through-space transmission, but *I* is also used specifically for through-bonds transmission: through-space transmission is then symbolized as *F* (for field effect). The symbols for the influence of substituents exerted through electron delocalization have variously been *M* (mesomeric), *E* (electromeric), *T* (tautomeric), *C* (conjugative), and *R* (resonance). Since the present fashion is to use the term ‘resonance effect’, *R* is the most commonly used symbol, although *M* is still seen quite often. Both the possible sign conventions are in use. The Ingold sign convention associates \rightarrow *electronegativity* (relative to hydrogen atom) with a negative sign, electropositivity with a positive sign. Thus the nitro group is described as electron-withdrawing by virtue of its $-I$ and $-M$ effects; chloro is described as a $-I$, $+M$ substituent, etc. For correlation analysis and \rightarrow *linear free energy relationships* this convention has been found to be inconvenient, for it is in contradiction to the sign convention for polar substituent constants (σ -constants). Authors concerned with these fields often avoid this contradiction by adopting the opposite sign convention originally associated with Robinson, for electronic effects. This practice is almost always associated with the use of *R* for the electron delocalization effect: thus the nitro group is a $+I$, $+R$ substituent; chloro a $+I$, $-R$ substituent, etc.

Ref.: [i] Muller P (1994) *Pure Appl Chem* 66:1077

WK

Electroosmosis — (also called electroendosmosis and endosmosis) The movement of a polar liquid through a capillary tubing or porous solid driven by an electrical potential difference. First described by F. F. Reuss in 1809. In fuel cells, electroosmosis causes protons moving through a proton exchange membrane (PEM) to drag water molecules from one side (anode) to the other (cathode). This phenomenon is utilized for the dessication of different objects, e.g., walls of buildings.

See also → *electrokinetic effect*, → *zeta potential*, → *Wiedemann*.

Ref.: [i] Newman J, Thomas-Alyea KE (2004) *Electrochemical systems*, 3rd edn. Wiley Interscience, Hoboken, pp 244

Electroosmotic (electroendosmotic) flow — (see → *electroosmosis*) The flow of an electrolyte solution in a capillary induced by an electric field. The flow rate is proportional to the potential difference applied, the → *dielectric permittivity* of the medium, the → *zeta potential*, the square of radius of the capillary, and inversely proportional to the → *viscosity* of the fluid phase. In → *capillary electrophoresis* the inner surface of the glass capillary is covered with silanol (Si–OH) functional groups. Depending on pH of the solution dissociation (i.e., deprotonation) may occur. The negative charges (Si–O[−]) on the surface are compensated by metal cations and H₃O⁺ ions in solution. Upon application of an electric field these metal cations migrate taking their aqueous solvation sheet with them. This results in a flow of liquid. Because of the mode of flow generation the flow is plug like, i.e., there is no velocity variation across the capillary cross section when compared with hydrodynamic flow as induced by e.g., a pump.

Ref.: [i] Altria KD (1996) *General guidelines to the operation of capillary electrophoresis methods and instrumentation*. In: Altria KD (ed) *Capillary electrophoresis guidebook: principles, operation, and applications*. *Methods in molecular biology*, vol. 52. Humana Press, Totowa

RH

Electroosmotic hold-up time (in capillary electromigration), t_{eo} — Time required for a liquid in a capillary to move due to → *electroosmosis* through the effective length of the capillary, L_{eff} . This time is usually measured as the → *migration time* of a neutral compound, called an electroosmotic flow marker, which is assumed to have an → *electroosmotic mobility* that is negligible compared to that of the analyte.

Ref.: [i] Riekkola ML, Jönsson JÅ, Smith RM (2004) *Pure Appl Chem* 76:443

WK

Electroosmotic mobility (in capillary electromigration), u or μ_{eo} → *Electroosmotic velocity*, ν_{eo} , divided by → *electric field (strength)*, E .

$$\mu_{eo} = \frac{\nu_{eo}}{E} .$$

Ref.: [i] Riekkola ML, Jönsson JÅ, Smith RM (2004) *Pure Appl Chem* 76:443

WK

Electroosmotic velocity, ν_{eo} — See → *electroosmosis*. In → *capillary electromigration*, this velocity is

positive, by convention, in the direction from the sample introduction end of the capillary to the detection end, otherwise it is negative. The electroosmotic velocity is the effective length of the capillary divided by the → *electroosmotic hold-up time*, $\nu_{eo} = L_{eff}/t_{eo}$.

Ref.: [i] Riekkola ML, Jönsson JÅ, Smith RM (2004) *Pure Appl Chem* 76:443

WK

Electroosmotic volume flow — The volume flow divided by → *electric field strength* through the whole plug or capillary.

Ref.: [i] Riekkola ML, Jönsson JÅ, Smith RM (2004) *Pure Appl Chem* 76:443

WK

Electrooxidation — Electrode reaction, when the energy of electrons in the working electrode is lower than the HOMO orbital of the substrate. Electrons are thus transferred from the studied compound to the working electrode, the working electrode is called → *anode*, it serves as an acceptor of electrons, i.e., as an oxidizing agent, the substrate becomes oxidized.

JL

Electrophile, electrophilic — An electrophile (or electrophilic reagent) is a reagent that forms a bond to its reaction partner (the nucleophile) by accepting both bonding electrons from that reaction partner. In an “electrophilic substitution reaction” the reagent supplying the entering group acts as an electrophile. For example,

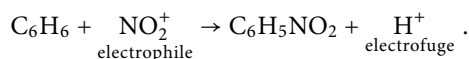

Electrophilic reagents are Lewis acids (→ *acid–base theories*). “Electrophilic catalysis” is catalysis by Lewis acids. The term “electrophilic” is also used to designate the apparent polar character of certain → *radicals*, as inferred from their higher relative reactivities with reaction sites of higher → *electron density*. See also → *electrophilicity*.

Ref.: [i] Muller P (1994) *Pure Appl Chem* 66:1077

WK

Electrophilicity — (1) The property of being → *electrophilic* (see → *electrophile*). (2) The relative reactivity of an electrophilic reagent. (It is also sometimes referred to as “electrophilic power”.) Qualitatively, the concept is related to Lewis acidity (→ *acid–base theories*). However, whereas Lewis acidity is measured by relative → *equilibrium constants*, electrophilicity is measured by relative → *rate constants* for reactions of different electrophilic

reagents towards a common substrate (usually involving attack at a carbon atom).

Ref.: [i] Muller P (1994) *Pure Appl Chem* 66:1077

WK

E

Electrophoresis — Movement of charged particles (e.g., ions, colloidal particles, dispersions of suspended solid particles, emulsions of suspended immiscible liquid droplets) in an electric field. The speed depends on the size of the particle, as well as the → *viscosity*, → *dielectric permittivity*, and the → *ionic strength* of the solution, and it is directly proportional to the applied electric field. In analytical as well as in synthetic chemistry electrophoresis has been employed to separate species based on different speeds attained in an experimental setup. In a typical setup the sample is put onto a mobile phase (dilute electrolyte solution) filled, e.g., into a capillary or soaked into a paper strip. At the ends of the strip connectors to an electrical power supply (providing voltages up to several hundred volts) are placed. Depending on their polarity and mobility the charged particles move to one of the electrodes, according to the attained speed they are sorted and separated. (See also → *Tiselius*, → *electrophoretic effect*, → *zeta potential*).

Refs.: [i] Simpson CF, Whittaker M (eds) (1983) *Electrophoretic techniques*. Academic Press, New York; [ii] James AM (1979) *Surf Colloid Sci* 11:121; [iii] Newman J, Thomas-Alyea KE (2004) *Electrochemical systems*, 3rd edn. Wiley Interscience, Hoboken, pp 1254

RH

Electrophoretic deposition — Electrophoretic deposition (EPD) is a combination of → *electrophoresis* and deposition to shape ceramic bodies or to coat a substrate from a colloidal suspension by a DC electric field. For the formation of ceramic bodies (e.g., sanitary ware) the depositing electrode is the shape of the ware and is designed such that the deposit can be easily released from it. Depending on the sign of the electric charge of the particles the depositing electrode can be the negative (cathodic electrophoretic deposition) or the positive electrode (anodic electrophoretic deposition).

Ref.: [i] Sarkar P, Nicholson PS (1996) *J Am Ceram Soc* 79:1987

AB

Electrophoretic effect — A moving ion driven by an electric field in a viscous medium (e.g., an electrolyte solution) is influenced in its movement by the → *relaxation effect* and the electrophoretic effect. The latter effect is caused by the countermovement of ions of opposite charge and their solvation clouds. Thus an ion is not moving through a stagnant medium but through a medium which is moving opposite to its own direction. This slows down ionic movement. See also → *Debye–*

Falkenhagen effect, → *Debye–Hückel–Onsager theory*.

Refs.: [i] Atkins PW (1994) *Physical chemistry*. Oxford University Press, Oxford, p 855; [ii] Bockris JOM, Reddy AKN (1998) *Modern electrochemistry*, vol. 1. Plenum Press, p 520

RH

Electrophoretic mobility, μ or μ_{ep} — The observed → *rate of migration* (in electrophoresis), ν , (or → *electrophoretic velocity*, ν_{ep}) divided by the magnitude of the → *electric field strength*, E , in a given medium. Mobilities are sometimes expressed with a negative sign, because the solutes or particles generally migrate in a direction opposite to the direction of the electric field (which is taken as a reference for that direction). In a solid support medium, only apparent values can be determined. The electrophoretic mobility of an ion is given by:

$$\mu_{ep} = \frac{ze}{f},$$

where f is the friction coefficient, z is the number of → *elementary electric charges* on the ion, and e is the elementary charge. The friction coefficient increases with the size of the ion and with the viscosity of the → *supporting (background) electrolyte*. For rigid spherical ions of radius r , moving in a continuum of viscosity η , the frictional coefficient may be estimated using → *Stokes law* as

$$f = 6\pi\eta r.$$

Friction coefficients for particles of other shapes, such as oblate or prolate ellipsoids, may be estimated using more complex equations.

Ref.: [i] Riekkola ML, Jönsson JÅ, Smith RM (2004) *Pure Appl Chem* 76:443

WK

Electrophoretic potential → *sedimentation potential*

Electrophoretic velocity, ν_{ep} , or rate of migration (in electrophoresis) — The velocity of a charged analyte under the influence of an electric field relative to the → *background (supporting) electrolyte*.

Ref.: [i] Riekkola ML, Jönsson JÅ, Smith RM (2004) *Pure Appl Chem* 76:443

WK

Electrophysiology — Electrophysiology is the study of the electrochemical phenomena associated with biological cells and tissues in animals, plants, bacteria, and insects. It involves measurements of electrical → *potentials* or → *current* on a wide variety of scales from single ion channel, to whole tissues like the heart, muscles, phloem,

or plasmodesmata. Electrical properties of animal and plant cells arise mostly from the electrochemical properties of their biomembranes. Electrophysiological study includes measurements of the electrical activity of neurons, phloem, xylem, plasmodesmata, and particularly the action potential propagation. The human body is made up of approximately 10^{13} cells, and roughly 10^{11} of them are neurons. The brain is the major component of the central nervous system; it is a highly sophisticated network of neurons. Neurons are classified as microdevices, which include many nanodevices such as ion channels, enzymatic systems, and different proteins. The average neuronal cell has a body, axon, and dendrites. In most neurons, the axon is protected by a myelin sheath. Glial cells are the main components of the sheath. Not only does the sheath serve as a protective covering, it also facilitates the rapid propagation of action potentials. The dendrites are small branches at the ends of the neuron. They are intricately connected to other dendrites forming a plexus or dendritic tree. Primarily, dendrites are responsible for receiving information. Gaps between dendrites are known as synaptic gaps, and they serve as avenues for neurotransmitters to travel. Neurons have the capability to become excited in response to various internal and external stimuli. The excitations induced are characterized as action potentials. These characteristic responses can be induced by stimuli such as: applied pressure, chemical substances, thermal stimuli, electrical stimuli, and mechanical stimuli. There are two major divisions of electrophysiology: intracellular recording and extracellular recording. Pipet-based recording of membrane currents is the mainstay in the characterization of cellular ion channels. Traditional patch clamp (Erwin Neher and Bert Sakmann, Nobel Prize, 1991) recording is accomplished by using a micromanipulator to position the tip of a glass pipet against the membrane of a cell. In voltage clamp mode, the membrane is clamped to a preset potential, and the current required to maintain this potential is recorded. Current recordings with different electrical protocols and in the presence of different reagents are used to characterize ion channel properties.

Refs.: [i] Volkov AG (ed) (2006) *Plant electrophysiology*. Springer, New York; [ii] Volkov AG, Brown CL (2006) *Nanodevices in nature*. In: Kumar CSSR (ed) *Nanodevices for life sciences*. Wiley-VCH, Weinheim, pp 440–463

AV

Electroplating — (or \rightarrow *electrodeposition*) is the process of depositing a usually thin layer of metal upon a usually metallic substrate (or any other conductor, e.g. graphite),

in order to improve the appearance, and/or to change the surface properties of the substrate. Earliest attempts of electroplating date back to 1805, when Luigi Brugnatelli (1761–1818) first performed electrodeposition of gold on a silver target, using the \rightarrow *Volta pile*. The science and technological use started when several patents for electroplating processes were issued in 1840, first by the English cousins Henry and George Richard Elkington, holding a monopoly on electroplating since then for many years. Nowadays, this technology is broadly used in electronics and communications industries, here especially using platinum, osmium, and ruthenium, e.g., for connectors, for the deposition of magnetic recording devices (heads, discs), for the fabrication of integrated circuits, boards, contacts, and other modern electronic instrumentation. It is also applied to increase the corrosion resistance of metal parts, e.g., in the automobile industry (chromium coatings are often applied to steel surfaces of automobile parts in order to make them more rust resistant), or for plating of gold or silver on jewelry and utensils.

The electroplating process is performed in a liquid electrolyte solution, or ‘plating bath’, containing the desired dissolved metal ions with possible additives (together called ‘plating bath formula’). Particular attention has to be given to the surface cleaning and preparation prior to electroplating, since contaminants and films (extrinsic) or native oxide layers (intrinsic) may cause poor adhesion. To remove undesired contaminants from the substrate surface, physical (ultrasonic agitation, brush abrasion) and chemical cleaning processes (surface-active chemicals, alkaline or acid cleaners) are frequently employed. The object to be plated is submerged into the plating bath, and acts as cathode. The positively polarized anode(s) and a power source complete the circuit of the electrolysis cell. By way of electrolysis, the metal ions are deposited on the surface of the target as a usually thin layer. When a current is applied, the electrode reaction occurring on the cathode is the reduction of the metal ions M^{n+} to metal M , according to: $M^{n+} + ne^{-} \rightarrow M$. The respective anode reaction is dependent on the anode material, which can either be the metal M to be deposited (\rightarrow *electrodissolution*), or made of an inert material, with the anodic reaction being oxygen evolution, i.e., $M \rightarrow M^{n+} + ne^{-}$, or: $O^{2-} \rightarrow 0.5O_2 + 2e^{-}$, respectively. In the latter case, the ‘plated out’ metal cations are not replaced via the anodic half-reaction. The thickness of the electroplated layer on the substrate is determined by the time duration of the plating; layer thicknesses typically vary from 0.1 to 30 μm . The geometric shape and contour of

the target affects the thickness of the deposited layer: Caused by the nonuniformity of the current distribution, thicker deposits crop up on the outside corners. Objects with geometrically complex surfaces, sharp corners and features therefore preferably deserve electroless plating techniques, which assure thin metallic coatings of uniform thickness without the application of an external current and therefore are independent of the target's geometry and matter (see there). The current efficiency of the electrodeposition process is defined as the ratio between the actual amount of metal deposited to that theoretically expected from → *Faradays law*.

So-called superlattice multilayers of two or more metals, as needed, e.g., for magnetic reading heads for computer hard drives, can be deposited using a single plating bath, but applying different potentials. Technically, one utilizes therefore a computer-controlled potentiostat controlling the cathode potential against a reference electrode. A pulse train-shaped potential is enforced, and the thickness of the layers is controlled by the width of the pulses, e.g., in the milliseconds range for a few pm-thick layers.

Refs.: [i] Lou HH, Huang Y (2006) *Electroplating*. In: Lee S (ed) *Encyclopedia of chemical processing (5 vols)*, vol. 2. Taylor and Francis, New York, pp 839–848; [ii] Schlesinger M, Paunovic M (eds) (2000) *Modern electroplating*, 4th edn. Wiley, New York; [iii] Stickney JL (2001) *Electrochemical atomic layer epitaxy (EC-ALE): Nanoscale control in the electrodeposition of compound semiconductors*. In: Alkire RC, Kolb DM (eds) *Advances in electrochemical science and engineering*, vol. 7. Wiley-VCH, pp 1–105; [iv] Kanani N (2004) *Electroplating: Basic principles, processes and practice*. Elsevier, Amsterdam

MHer

Electroplating additives — Chemical substances, mainly organic, added in small amounts (usually in a range of mg per liter) to an → *electroplating bath* in order to improve the quality of the deposited material. They are surface-active molecules that strongly adsorb on the surface of the → *electrode*. Thus the additives strongly affect the phenomena occurring at the electrode–solution → *interface*: such as the → *nucleation* and crystal growth processes, → *electron transfer* rates and sometimes the changes in mechanism of the → *electrode reactions*. It is possible to distinguish several groups of electroplating additives: 1) brighteners – change the light reflectance from the surface of the deposits, 2) grain refiners – improve the crystal structure, 3) stress reducers – decrease the internal stress, 4) wetting agents – make the electroplated details more hydrophilic (see → *hydrophilicity*).

Ref.: [i] Dini JW (1993) *Electrodeposition: The materials science of coatings and substrates (Materials science and process technology series), a handbook*, 2nd edn. Noyes Publications, Norwich

ings and substrates (Materials science and process technology series), a handbook, 2nd edn. Noyes Publications, Norwich

MD

Electroplating bath — Commonly used term describing a solution used for → *electrodeposition* of galvanic layers. Electroplating baths can be divided into two groups: electrolytic deposition and for electroless (non-electrolytic) deposition. The first group is more popular and contains all solutions for the plating procedures that require an external current source for running the process. Those solutions contain three groups of dissolved substances. Two of them are present in the plating bath solution at a relatively high concentration and are called main components. They are sources of the deposited materials, usually salts or anions with a metallic central atom as, for example, NiSO₄ and MoO₄[−] that are present in the bath used for the Ni–Mo → *alloy deposition*. The concentrations of the main components decrease during the deposition process. The second group is formed by the chemical compounds added to the solution to establish the appropriate environment. It includes compounds to control pH (buffering systems), inorganic and organic ligands for metals ions complexation, and inert electrolytes used for increasing electrical conductivity of the solution. In the baths used for electroless plating one of the main components of the solution is a reducing agent necessary for the deposition of metals in the process which requires no current source for the plating. The products of the oxidation of the compounds can remain in the solution as in the case of silver mirror deposition (reduction of silver complexes by formaldehyde with deposition of silver and formation of formic acid). In some cases, both products of the redox reaction can be deposited (e.g., electroless deposition of Ni–P alloy). The last group contains compounds often added to the plating bath solution, usually in very small amounts, for improving the quality of the deposit (see → *electroplating additives*).

Ref.: [i] Dini JW (1993) *Electrodeposition: The materials science of coatings and substrates (Materials science and process technology series), a handbook*, 2nd edn. Noyes Publications, Norwich

MD

Electropolishing — is a process of removing small amounts of metal from metal electrode surfaces using electric current. Typically, the electrode (anode) is immersed in → *electrolyte* and positively polarized to a controlled potential applied from an external source. The electric circuit is closed using another electrode acting as a cathode. Positive → *polarization* causes oxidation and dissolution of surface atoms (to produce soluble ions) in

amounts equivalent to the charge passed. Not only the potential applied, but the size and position of the cathode is also crucial to achieving a good polish. Electropolishing is frequently used to clean surfaces of noble metal (e.g., Pt, Au) single crystals and to etch tip probes for scanning nanoscopic techniques (e.g., STM, AFM); also, in industry, to passivate steel surfaces through their enrichment with chromium (that reacts with oxygen from air to create chromium-rich metal oxide passive layers). Approaches involving alternating or pulse currents are used as well.

See also → *electrochemical machining*.

PK, AL

Electropolymerization — Polymerization reactions can be initiated electrochemically. In the electrode reaction of organic compounds usually a highly reactive charged radical is formed which may undergo further transformations [i–iii]. Overwhelmingly, oxidative electropolymerization is applied for the preparation of electronically → *conducting polymers* from cheap, simple aromatic (mostly amines, e.g., aniline, *o*-phenylenediamine, diphenylamine) and heterocyclic compounds (e.g., pyrroles, thiophenes, azines). Cathodic electropolymerization is seldom used; however, there have been several attempts, e.g., the electrochemical dehalogenation polymerization of dibromoderivatives of phenazine or thiophene. → *Redox polymers* can also be deposited electrochemically, e.g., poly(vinylferrocene) by using vinylferrocene starting compound.

Electrochemical polymerization is preferred to chemical polymerization, especially if the polymeric product is intended to be used as a polymer film electrode, thin layer sensor, in microtechnology etc., because the potential control is a precondition of the production of good-quality material and the polymer film is formed at the desirable spot that serves as an anode during the synthesis.

The growth of the polymer film can be followed by → *cyclic voltammetry* since the current peaks related to the polymer redox transformations increase as more and more polymer is deposited. The increase of the surface mass can be detected by using an → *electrochemical quartz microbalance*. Such an example is shown in the Figure. In this experiment the positive potential limit of cycling was gradually decreased in order to avoid overoxidation of the polyaniline (PANI) formed. It does not affect the rate of polymerization, i.e., the film growth, since the electrooxidation of aniline is an autocatalytic process.

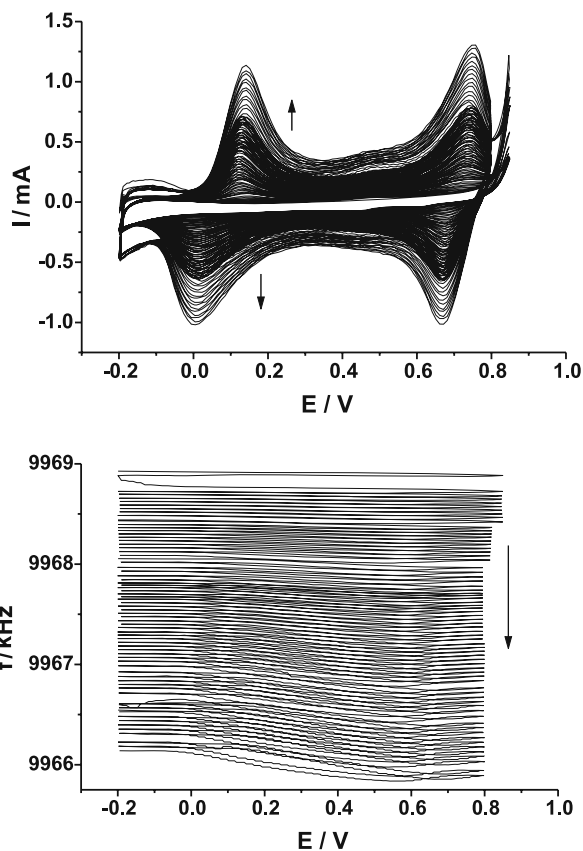

Electropolymerization — Figure. Cyclic voltammograms and the simultaneously detected EQCM frequency changes during the electropolymerization of aniline at a platinum electrode. Sweep rate: 100 mV s^{-1} . Solution composition: 0.2 mol dm^{-3} aniline in $1 \text{ mol dm}^{-3} \text{ HClO}_4$

The chemical reaction mechanism of electropolymerization can be described as follows. The first step in course of the oxidative electropolymerization is the formation of cation radicals. The further fate of this highly reactive species depends on the experimental conditions (composition of the solution, temperature, potential or the rate of the potential change, galvanostatic current density, material of the electrode, state of the electrode surface, etc.). In favorable case the next step is a dimerization reaction, and then stepwise chain growth proceeds via association of radical ions (RR-route) or that of cation radical with a neutral monomer (RS-route). There might even be parallel dimerization reactions leading to different products or to the polymer of a disordered structure. The inactive ions present in the solution may play a pivotal role in the stabilization of the radical ions. Potential cycling is usually more efficient than the potentiostatic method, i.e., at least a partial reduction

of the oligomer helps the polymerization reaction. It might be the case if the RS-route is preferred, and the monomer carries a charge, e.g., a protonated aniline molecule. (PANI can be prepared only in acid media, at higher pH values other compounds are formed. Even in acidic solutions beside the head-to-tail coupling resulting in the formation of *p*-aminodiphenylamine, tail-to-tail dimerization leading to benzidine also occurs, however, the latter is considered as a minor dimer intermediate because the rate constant of dimerization for RR coupling to produce the former product [k is ca. $10^8 \text{ dm}^3 \text{ mol}^{-1} \text{ s}^{-1}$] is about 2.5 times higher than that for the tail-to-tail dimer.) A relatively high concentration of cation radicals should be maintained in the vicinity of the electrode. The radical cation and the dimers can diffuse away from the electrode, usually the intensive stirring of the solution decreases the yield of the polymer production. The radical cations can take part in side reactions with nucleophilic reactants (e.g., solvent molecules) present in the solution. Usually the oxidation of the monomer is an irreversible process and takes place at higher positive potentials than that of the reversible redox reaction of the polymer. However, in the case of azines reversible redox reactions of the monomers occur at less positive potentials and this redox activity can be retained in the polymer, i.e., the polymerization reaction that takes place at higher potentials does not alter substantially the redox behavior of the monomer.

The kinetics of the electrodeposition process depends on the same factors enlisted above, although the role of the material and the actual properties of the electrode surface is evidently more pronounced. Specific interactions such as the wetting may determine the \rightarrow nucleation and the dimensionality of the growth process. Two or more stages of the polymerization process can be distinguished. In the case of PANI it has been found that first a compact layer (its thickness is ca. 200 nm) is formed on the electrode surface via a potential-independent nucleation and a two-dimensional (2-D, lateral) growth of PANI islands. In the advanced stage 1-D growth of the polymer chain with continuous branching leading to an open structure takes place. The film morphology (compactness, swelling) is strongly dependent on the composition of the solution, notably on the type of counter ions present in the solution, and the plasticizing ability of the solvent molecules. The growth rate is proportional, except for the early induction period, to the aniline concentration. In the synthesis of polypyrrole (PP) the current density is a crucial parameter. At low current densities the structure of

PP is dominated by the one-dimensional microscopic structure of the polymer formed. The structure substantially affects the conductivity of the polymer phase, the conductivity of the 2-D form is higher, and its temperature dependence is lower. The higher conductive 2-D islands are interconnected by short 1-D chain segments acting as tunneling barriers. The film growth at sub- μm or μm -structured substrates is not restricted to conductive substrate domains. Instead, after the film thickness has risen to the level of the surrounding insulator a lateral outward growth on the nonconductive part also occurs; this phenomenon is of importance concerning micro-mechanical applications. Although the region close to the substrate (electrode metal) surface shows a more or less well-defined structure, in general the polymer layer can be considered as an amorphous material. However, there are rare reports on crystalline structure, too. In the case of thiophene the relatively high potential required for the oxidation prevents the use of many metallic substrates. The electrochemical oxidation of substituted thiophenes and thiophene oligomers yields conducting polymers and these compounds can be electropolymerized at less positive potentials. Therefore, it is a good strategy to use these derivatives instead of thiophene. The template synthesis with using polycarbonate or other membranes has been exploited to obtain nanostructures. The application of combined electrochemical and nonelectrochemical techniques, such as piezoelectric microgravimetry at \rightarrow EQCM, radiotracer (\rightarrow radiochemical methods in electrochemistry, \rightarrow ellipsometry, spectroscopies, microscopies (\rightarrow STM, \rightarrow AFM), \rightarrow probe beam deflection, conductivity etc. has allowed a very detailed insight into the nature of electropolymerization and deposition processes, and consequently now the production of conducting polymers, polymeric films, and composites with desired properties is a well-established area of electrochemical and material sciences [i].

Refs.: [i] Inzelt G, Pineri M, Schultze JW, Vorontyntsev MA (2000) *Electrochim Acta* 45:2403; [ii] Kaner RB (1990) *Preparation and properties of electrochemically synthesized polymers*. In: Linford RG (ed) *Electrochemical science and technology of polymers-2*. Elsevier, London, pp 97–147; [iii] Inzelt G (2008) *Conducting polymers*, Springer, Berlin Heidelberg

GI

Electroporation — (depending on the system under study also called membrane electroporation). An electric field applied to a \rightarrow membrane or on a larger scale to an area of skin changes the permeability of the membrane/skin for molecular substances (or in the latter case

for genes and DNA) by the small current flowing as an effect of the \rightarrow *electric field*.

Refs.: [i] Neumann E (1996) *Naturw Rdsch* 49:43 [ii] Neumann E (1995) *Forschung an der Universität Bielefeld* 11:16; [iii] Müller HP, Sprafke A, Neumann E (1989) *Biol Chem Hoppe-Seyler* 370:937; [iv] Neumann E, Tonsing K, Siemens P (2000) *Bioelectrochem* 51:125

RH

Electroraffination — (see also \rightarrow *electrorefining*) Purification of metals by means of dissolution and subsequent electrodeposition. Common method in \rightarrow *electrometallurgy* for the removal of impurities from raw metals. Upon anodic dissolution the metallic constituents of the anode are dissolved as cations, oxyanions, or complex ions. All impurities – whether metallic or not – are also dissolved or will fall to the bottom of the cell. At the cathode set to a suitable potential (in most cases only fractions of one volt are needed) the desired metal is deposited. Less noble metals stay in solution, they can be recovered by processing the electrode solution. Metals more noble than the metal under consideration are in most cases not dissolved anodically, instead they settle in the solid deposit at the cell bottom. From this residue they can be recovered.

Ref.: [i] Pletcher D, Walsh FC (1993) *Industrial electrochemistry*. Blackie Academic, London

RH

Electroreclamation \rightarrow *electroremediation*

Electroreduction \rightarrow *Electrode reaction*, where the energy of electrons in the working electrode is higher than the LUMO orbital of the substrate. Electrons are thus transferred from the working electrode to the studied compound, the working electrode is called \rightarrow *cathode*, and serves as a donor of \rightarrow *electrons*, i.e., as a reducing agent, and the substrate is reduced.

JL

Electrorefining — Electrolytic process aimed at the purification of a metal (M). Impure metal anodes are electrochemically dissolved in a suitable electrolyte (solution of a M salt) to form ions of the desired element, which are reduced at the cathodes, effecting a selective deposition of M with high purity. Depending on its nature, the anode impurities are left as anodic slimes (collected from the bottom of the electrolytic cell) or as ions in the electrolyte (continuously bled to a purification circuit). This performance can be easily understood by noting that the elements with higher reduction potential than M will not undergo oxidation and thus are re-

tained in the anode residues (slimes) while those metals less noble than M are oxidized, contaminating the electrolyte solution, but its cathodic reduction will not occur before the deposition of M; they built up during the operation and can eventually contaminate the deposited M (mainly by occlusion) unless they form insoluble salts which will also integrate the slimes. Accordingly, the main electrode reactions are:

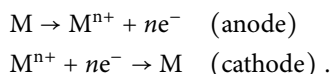

As the cathodic reaction is the reverse of the anodic one, the theoretical thermodynamic cell potential is 0 V. In actual practice, the cell voltage required to drive the process accounts for the voltage drops in the electrolyte, anode and cathode electrical connections, electrical circuit losses, and overpotentials for both electrode reactions when occurring at a reasonable rate.

The most relevant technical parameters in electrorefining are the purity of the cathodic deposit, the production rate, and the specific energy consumption (energy/unit mass of produced metal) which are affected by different variables, namely anode composition, electrolyte conditions (purity, metal ion concentration, temperature, circulation rate), current density, and electrode spacing.

Usually electrorefining is a major unit operation of extractive metallurgy; modern industrial plants operate with high current efficiency (the unused current is mainly wasted by leakage currents to the ground and anode to cathode short circuits) as a result of improved monitoring and control systems.

Electrorefining in aqueous media is extensively applied for the production of copper, nickel, lead, tin, cobalt, silver, and gold, while in molten salt electrolytes it is practically limited to aluminum.

Refs.: [i] Pletcher D, Walsh FC (1990) *Industrial electrochemistry*, 2nd edn. Chapman and Hall, London; [ii] Davenport WG, King M, Schalsing M, Biswas AK (2002) *Extractive metallurgy of copper*, 4th edn. Elsevier, Oxford

LMA

Electroreflectance — The reflectance intensity of polarized light reflected from a smooth surface is a function of the refractive index. The basic equations, derived originally by Fresnel, for light polarized parallel to the plane of reflection take the form $r^p = \frac{n_a \cos \hat{\phi}_b - \hat{n}_b \cos \phi_a}{n_a \cos \hat{\phi}_b + \hat{n}_b \cos \phi_a}$ where r^p is the (complex) reflection coefficient whose absolute square is the reflected intensity, n_a is the refractive index of the incident medium, usually assumed to be

transparent (n_a real), with the light incident at angle ϕ_a , and \hat{n}_b the refractive index of the reflecting medium, assumed as optically absorbing ($\hat{n}_b = n_b - ik_b$), where k_b is the optical absorption coefficient at the relevant wavelength. The angle ϕ_b is complex if the reflecting medium is absorbing, and is given by Snell's law: $n_a \sin \phi_a = \hat{n}_b \sin \phi_b$. The basis of the electroreflectance technique is that the refractive index of any material is a function of its internal electric field; in general this dependence is not large and it arises because during the optical transition the electron may acquire a component of momentum parallel to the field, permitting nonvertical optical transitions in k -space. Where the transition takes place to energy levels well within the electronic bands, this has little effect, but it has a much more marked effect on transitions taking place at the band edges of a semiconductor, as can be seen from the diagram. The structure is relatively complex at the band-edge, as can be seen, and extends usually over many tens of nm in the visible range. The theory of the effect is quite involved, but the critical factor is the relative magnitudes of the thermal broadening of the optical absorption, $\hbar\Gamma$, and the energy associ-

ated with the electric field, $\hbar\theta = (|\mathbf{E}|^2 e_0^2 / 2\mu\hbar)^{1/2}$, where μ is the joint effective mass of the electron undergoing the transition. If $\Gamma \gg \theta$ then the response reduces to the third derivative of the dielectric function, and the sensitivity of the line shape on the electric field \mathbf{E} is lost. If $\Gamma \ll \theta$, the behavior is much more complex and the line shape shows considerable sensitivity to \mathbf{E} .

The technique can be used, therefore, to probe details of the band-edge, and as such is an extremely accurate method of determining bandgap. In favorable cases, such as GaAs, it can also be used to determine the magnitude of the internal electric field within the semiconductor and its variation with applied potential. A typical electroreflectance spectrum for p -GaAs (carrier density $2.7 \times 10^{17} \text{ cm}^{-3}$) for four different electrode potentials is shown in the figure together with a model fit for GaAs assuming that the potential indicated is dropped in the depletion layer of the semiconductor. It can be seen that the fit is very good, suggesting that the theory, though complex, does reproduce the basic physics, and that at least for this sample, the entire electric field is accommodated in the depletion layer rather than in surface states.

Refs.: [i] Hamnett A (1987) *Semiconductor electrochemistry*. In: Compton RG (ed) *Comprehensive chemical kinetics*, vol. 27. Elsevier, Amsterdam, pp 61–246; [ii] Compton RG, Hamnett A (1989) (eds) *Novel methods of studying the electrode–electrolyte interface*. *Comprehensive chemical kinetics*, vol. 29. Elsevier; [iii] Bachelor R, Brown A, Hamnett A (1990) *Phy Rev B* 41:1401; [iv] Batchelor RA, Hamnett A, Peter LM, Peat R (1991) *J Appl Phys* 70:266

AH

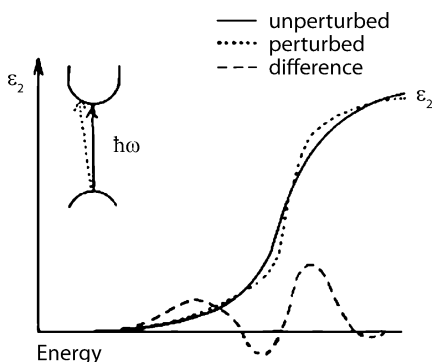

Electroreflectance — Figure 1

Electroremediation — Electrochemical process for in-situ decontamination and restoration of polluted soils, sludge, or other solid wastes. It is also currently known as electroreclamation, electrorestoration, or electrokinetic remediation. The technology involves the application of a low-intensity direct current across inert electrode pairs

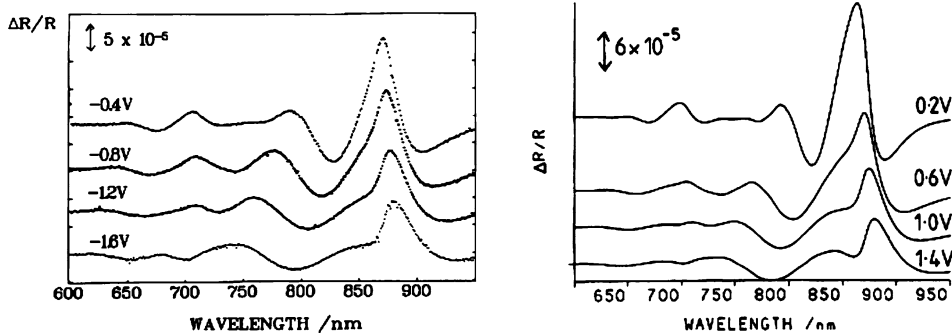

Electroreflectance — Figure 2

buried into the contaminated area. Ground water and an externally supplied process fluid give the required conductivity for carrying out the treatment. The contaminants are driven to the electrodes by ionic \rightarrow migration or/and \rightarrow electroosmosis (caused by the drag interaction between the liquid and the charged particles of the porous soil). At the electrodes, besides probable cathodic metal deposition, the major process is the electrolysis of water:

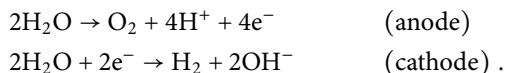

The migration of H^+ and OH^- towards the cathode and the anode, respectively, generates acid and base fronts. The H^+ movement promotes the removal of metal cations adsorbed on the soil and the dissolution of contaminant salts, but can also affect the transport of the polluting cations. The migration of OH^- causes the precipitation of the cations, avoiding their reduction at the cathodes or their removal from the pumped-out catholyte solution (e.g., by ion-exchange, chemical precipitation, or electroextraction). To prevent these adverse effects, accurate pH control is required, usually by applying electrode depolarization techniques and process fluid conditioning.

Refs.: [i] Page MM, Page CL (2002) *J Environ Eng* 128:208; [ii] Acar YB, Gale RL, Alshawabkeh AN, Marks RE, Puppala S, Bricka M, Parker R (1995) *J Hazard Mater* 40:117; [iii] Rajeshwar K, Ibanez JC (1997) *Environmental electrochemistry, fundamentals and applications in pollution abatement*. Academic Press, San Diego

LMA

Electrorestoration \rightarrow electroremediation

Electrorheological fluid (also called electroviscous fluid) — A fluid that changes its \rightarrow viscosity upon application of an external DC electric field in such a way that it becomes highly viscous. Electrorheological fluids usually consist of a solvent in which colloidal particles are suspended in high concentration. Due to a mismatch of the dielectric properties of solvent and particles, the particles align in rows (so-called fibrillation) and stiffen the suspension. The effect was observed first by Willis Winslow, an American engineer [i] who had dispersed starch in mineral oil. The electrorheological effects differ for various solvents and dispersants. For the structure and dynamics of these fluids see [ii–iii]. The ms \rightarrow response time of these systems make them interesting for engineers, esp. for designing fast electromechanical actuators. Also some homogeneous, i.e., nonparticulate

liquids, e.g., liquid crystals, exhibit electrorheological properties [iv]. With magnetic particles as dispersants one obtains magnetorheological fluids that exhibit a similar behavior upon application of a magnetic field. See also \rightarrow electroconvection for liquids with a low content of dispersed particles.

Refs.: [i] Winslow WM (1949) *J Appl Phys* 20:1137; [ii] Martin JE, Odinek J, Halsey TC, Kamien R (1998) *Phys Rev E* 57:756; [iii] Stangroom JE (1991) *J Stat Phys* 64:105; [iv] Tse K-L, Shine AD (2000) *Macromolecules* 33:3134

FS

Electrorotation — An effect where a particle is caused to rotate as a result of being subjected to a rotating \rightarrow electric field. A typical experimental arrangement is shown in the figure below, where a rotating field is generated by energizing four electrodes with sinusoidal voltages, having the same magnitude and frequency ω , but phased 90° apart. As shown in the figure, a practical way of achieving this is by placing the particle in a fluid encompassed by four electrodes, energized using a sine-wave and cosine-wave oscillator. In general, a rotating field can be generated by ' n ' electrodes, energized by sinusoidal signals of $360/n$ degree phase separation. A historical review of electrorotation has been given by Arnold and Zimmermann [i].

The electric field ' E ' induces a dipole ' m ' (\rightarrow dipole moment) in the particle. This dipole moment either leads or lags the rotating field vector, depending on the frequency of the applied voltages and the charge relaxation times of the particle and surrounding fluid (\rightarrow dielectric relaxation). This phase difference between the rotating field and the induced dipole moment results in a rotational torque being applied to the particle, causing the particle to rotate. If the dipole moment lags the field in phase, the particle will rotate in the same direction as the rotating field (co-field rotation). This is usually observed for the case where

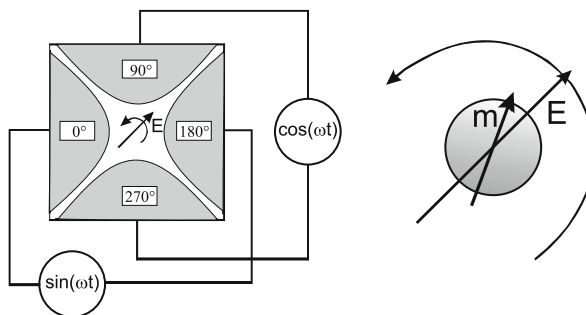

Electrorotation — Figure

the charge relaxation time of the particle is less than that of the surrounding fluid. For a reversal of this situation, where the dipole leads the field, the sense of the torque is reversed and the particle rotates against the field direction (anti-field rotation). This is commonly observed when performing electrorotation experiments on biological cells at low frequencies, where the electrical insulating properties of the outer cell membrane provides a situation where the charge relaxation time of the cell is effectively longer than that of the surrounding fluid. Electrorotation has become an important tool for the noninvasive characterization of cells [ii–iv].

Electrorotation differs in many respects to → *Quincke rotation* where a particle can spontaneously rotate in an arbitrary sense when subjected to a strong enough DC electric field.

Refs.: [i] Arnold WM, Zimmermann U (1988) *J Electrostatics* 21:151; [ii] Hu X, Arnold WM, Zimmermann U (1990) *Biochim Biophys Acta* 1021:191; [iii] Yang J, Huang Y, Wang X et al. (1999) *Biophys J* 76:3307; [iv] Pethig R, Jakubek LM, Sanger R et al. (2005) *IEE Proc Nanobiotechnol* 152:189

Electroscope — was one of the first instruments to indicate electric → *charge* [i]. The instrument consists of two thin leaves of gold foil suspended from a conductive support. When the metallic holder is charged by induction or by contact, the leaves receive similar electric charges and repel each other due to the → *Coulomb force*, indicating the charge stored on them. The instrument is usually enclosed in an evacuated glass jar to minimize charge leakage.

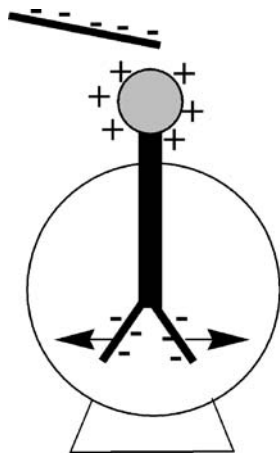

Electroscope — Figure

Ref.: [i] Heilbron JL (1979) *Electricity in the 17th & 18th centuries: A study in early modern physics*. University of California Press, Berkeley
EK

Electrospray mass spectrometry (ESMS) — The electrospray component of ESMS [i] provides a very “soft” method of transferring ions from solution to the gas phase with minimal risk of decomposition and fragmentation of ions prior to their determination by mass spectrometry. Ideally suited for the determination of charged solution species which are frequently generated in electrochemical experiments [ii].

Refs.: [i] Yamashita M, Fenn JB (1984) *J Phys Chem* 88:4451 and 4671; [ii] Bond AM (2002) *Broadening electrochemical horizons*. Oxford University Press, Oxford, pp 117–123

AMB

Electrosorption — At the → *interface* between the electrode metal (or other electron conductor) and the electrolyte, beside the usual forces (e.g., → *van der Waals forces*) causing a concentration change (→ *adsorption*), the potential difference between phases plays a determining role. The potential difference may arise spontaneously or it can be maintained, e.g., by using a → *potentiostat*. Because the surface coverage is a function of both the concentration of the adsorbate and the → *electrode potential*, this type of adsorption is called electrosorption. Not only the purely electrostatic adsorption shows potential dependence, but also the specific ionic adsorption, the adsorption of uncharged molecules (e.g., dipoles) and the → *chemisorption* (e.g., that of hydrogen, oxygen, organic molecules) are influenced by the electrode potential. Generally the surface coverage vs. potential function is parabolic. A knowledge of the electrosorption is crucial regarding many electrode reactions, especially in the case of → *electrocatalysis*. (See also → *adsorption constant*, → *adsorption isotherms*, → *chemisorption of hydrogen*, → *chemisorption of oxygen*, → *differential capacity*, → *double layer*, → *electrosorption valency*, → *Frumkin adsorption isotherm*, → *Gibbs–Lippmann equation*, → *Langmuir adsorption isotherm*, → *Lippmann equation*, → *potential of zero charge*, → *surface concentration*).

Refs.: [i] Gileadi E (1967) *Electrosorption*. Plenum Press, New York; [ii] Bockris J'OM, Srinivasan S (1969) *Fuel cells: their electrochemistry*. McGraw-Hill, New York, p 96; [iii] Horányi G (2002) *State of art: present knowledge and understanding*. In: Bard AJ, Stratmann M, Gileadi E, Urbakh M (eds) *Thermodynamics and electrified interfaces*. *Encyclopedia of Electrochemistry*, vol. 1. Wiley-VCH, Weinheim, p 349

GI

Electrosorption valency — A quantity describing the \rightarrow adsorption with \rightarrow charge transfer from the adsorbate to the electrode surface. The thermodynamic approach to the problem was initially outlined in the context of \rightarrow hydrogen adsorption on platinum with formation of hydrogen adatoms with non-zero residual charge (the effective interfacial dipoles), with simultaneous decrease of the ionic \rightarrow double-layer capacity [i]. It was later assumed that a partial charge transfer is possible in the course of redox reaction, and the notions of true (or microscopic) charge transfer coefficient λ was introduced [ii] by means of presenting the transition of Ox to Red ($\text{Ox} + e^- \rightleftharpoons \text{Red}$) by two subsequent steps: $\text{Ox} + n_1 e^- \rightleftharpoons \text{A}$; $\text{A} + n_2 e^- \rightleftharpoons \text{Red}$, with an intermediate adsorbed state A. The quantities n_1 and n_2 (giving unity in sum) were named the formal charge transfer coefficients [iii]. Chemisorption of both Ox and Red was assumed to stop after one of these steps, resulting in formation of A. According to [iv], the formal charge-transfer coefficients can be presented as $n_1 = -(\partial\Gamma_{\text{Red}}/\partial\Gamma_{\Sigma})_E$ and $n_2 = (\partial\Gamma_{\text{Ox}}/\partial\Gamma_{\Sigma})_E$, where $\Gamma_{\Sigma} = \Gamma_{\text{Ox}} + \Gamma_{\text{Red}}$, and E is the electrode potential. Both n_1 and n_2 coefficients mirror not only a portion of charge transferred from the adsorbate to the electrode, but also contain a component resulting from the reconstruction of the ionic double layer. In contrast to λ , these quantities can be obtained from electrochemical measurements. Formality of n_1 and n_2 is well illustrated by the example of thallium amalgam/ Tl^+ aqueous solution system. For this system, n_2 undergoes a break at certain potential ($n_2 \rightarrow \infty$) [v]. The quantity having a meaning of $n_{1(2)}$ was introduced as electrosorption valency γ [vi], and there were attempts to separate the true charge-transfer coefficient from γ [vi, vii]. Bringing into use ‘valency’ in relation to formal charge transfer was claimed as misleading [viii]. The valency notion belongs to quantum mechanics and should be applied exclusively to description of the electronic density distribution inside an adsorbate/adsorbent system [ix]. Systematic consideration can be found in [x].

Refs.: [i] Frumkin AN, Shlygin AI (1936) *Acta physicochim URSS* 5:819; [ii] Lorenz W, Salie G (1961) *Z phys Chem NF*29:390, 408; [iii] Frumkin AN, Damaskin BB, Petrii OA (1975) *Z phys Chem* 256:728; [iv] Grafov B, Pekar E, Petrii O (1972) *J Electroanal Chem* 40:179; [v] Frumkin AN, Polianovskaya NS, Damaskin BB (1976) *J Electroanal Chem* 73:267, 273; [vi] Vetter K, Schultze J (1972) *Ber Bunsenges phys Chem* 76:920, 927; [vii] Schultze J, Koppitz F (1976) *Electrochim Acta* 21:327, 337; Schultze JW, Rolle D (1997) *Can J Chem* 75:1750; [viii] Frumkin A, Damaskin D, Petrii O (1974) *J Electroanal Chem* 53:57; [ix] de Levie R (2004) *J Electroanal Chem* 562:273; [x] Trasatti S, Parsons R (1986) *Pure Appl Chem* 58:437

Electrostatic field \rightarrow electrical (electric) field

Electrostatic potential \rightarrow potential, electric \sim

Electrostenolysis \rightarrow Braun first reported in 1891 the effect that an oxidation and a reduction reaction can occur on opposite surfaces of a high-resistance membrane in a solution when there is a large electric potential gradient across the membrane [i–iii]. This can lead to the precipitation of a metal on the surface of the membrane facing the anode, and evolution of oxygen on the surface facing the cathode. Braun coined the term electrostenolysis. The effect has been explained as being due to a large streaming potential resulting from the strong forced electrolyte flow (\rightarrow electroosmotic flow) through the membrane pores; however, a conclusive study of the effect has not yet been published.

Refs.: [i] Braun F (1891) *Wied Ann* 42:450; [ii] Braun F (1891) *Wied Ann* 44:473; [iii] Homes HN (1914) *J Am Chem Soc* 36:784

FS

Electrostriction — The change of shape of an insulating material (dielectric) under the effect of an electric field. The deformation is proportional to the square of the polarization.

RH

Electrosynthesis — Synthesis performed with the help of \rightarrow electrolysis. Electrosynthesis is performed both on laboratory as well as on an industrial scale, and both organic and inorganic compounds are synthesized. In most cases, electrosynthesis affords divided cells, i.e., separation of the \rightarrow anolyte and \rightarrow catholyte by a \rightarrow diaphragm to prevent reactions between the products of the reaction proceeding at the \rightarrow anode with those formed at the \rightarrow cathode.

See also \rightarrow aluminum production, \rightarrow Baizer–Monsanto process, \rightarrow chlor-alkali production, \rightarrow electrochemical cell, \rightarrow fluidized bed electrodes, \rightarrow H-cell, \rightarrow Swiss-rod cell, \rightarrow three-dimensional electrodes, \rightarrow two-phase electrolysis.

Refs.: [i] Baizer MM, Lund H (eds) (1983) *Organic electrochemistry*, 2nd edn. Marcel Dekker, New York; [ii] Zirngiebl E (1993) *Einführung in die Angewandte Elektrochemie*. Salle & Sauerländer, Frankfurt; [iii] Sperry JB, Dennis L., Wright DL (2006) *Chem Soc Rev* 35:605

FS

Electrotyping \rightarrow Galvanoplastics

Electroviscous effects — Collective effects (\rightarrow electrokinetic effects) by which the presence of an electrical

OP

→ *double layer* influences the flow behavior of a liquid. Usually, it is the double layer of charged particles suspended in the liquid or → *polyelectrolytes* dissolved in solution. Three electroviscous effects are known: (a) the primary electroviscous effect: Increase of fluid viscosity due to the distortion of the double layer during shear. (b) The secondary electroviscous effect: Increase of fluid viscosity due to the interaction or overlap of adjacent double layers. (c) The tertiary electroviscous effect: Variation in fluid viscosity caused by geometrical changes within the fluid due to double-layer interactions. Thus, the viscosity of polyelectrolyte solutions depends on the conformation of the molecules, which in turn is affected by intramolecular electrostatic interactions between charged parts of the polymer backbone or side chains.

The electroviscous effects are observed as variations of viscosity upon application of outer electric fields, and as build-up of potential gradients upon flow of such fluids. See also → *electroconvection*, → *electrorheological fluid*, → *sedimentation potential*, → *electrokinetic effect*, → *electroendosmotic flow*.

Refs.: [i] Hackley VA, Ferraris CF (2001) *Guide to rheological nomenclature: measurements in ceramic particulate systems*. NIST Special Publication 946. Washington, U.S. Government Printing office

FS

Electrowetting — The change of → *contact angle* of liquids (mostly in form of droplets) with a solid electrode upon application of a potential difference [i]. The phenomenon is based on the dependence of the interfacial tension on electrode potential (→ *Lippmann equation*), and on the dependence of contact angle on → *interfacial tension* (→ *Young's equation*). Electrowetting can be used to manipulate small aqueous droplets sandwiched between two plates of hydrophobized electrodes. Applications range from chemical analysis, displays, optical systems, to cooling devices for electronic systems [ii, iii].

Refs.: [i] Beni G, Hackwood S (1981) *Appl Phys Lett* 38:207; [ii] Srinivasan V, Pamula VK, Fair RB (2004) *Anal Chim Acta* 507:145; [iii] Pamula VK, Chakrabarty K (2003) *Proc ACM Great Lakes Symposium on VLSI*, pp 84–87

FS

Electrowinning — The extraction of metals from their compounds by → *electrolysis* of solutions containing the metal ions. Usually electrowinning refers to mass production of metals from their ores after dissolution in appropriate medium, or in molten salts at high temperatures. The basis of electrowinning is electrolysis, in which the produced metal is plated on the cathode of

an electrochemical production cell. Electrowinning usually produces either impure metal or mixtures of metals, which are later purified. In contrast to electroplating, the physical form of the produced metal is of minor importance, while high production rates and efficient energy utilization are of great significance.

Electrowinning of metals in aqueous solutions is applicable to those metals that possess high electrochemical reduction potentials, such as silver, copper, cadmium, and zinc. Magnesium, aluminum, and sodium, like other reactive metals, are electro-produced from molten salt baths, such as NaCl/CaCl₂ mixture at ca. 600 °C for sodium and MgCl₂/NaCl/CaCl₂ eutectic mixture at ca. 750 °C for magnesium.

Electrowinning is also used frequently to reduce metallic contamination in wastewater from production plants, along with the benefit of the metal recovery.

Refs.: [i] Wendt H, Kreysa G (1999) *Electrochemical engineering: Science and technology in chemical and other industries*. Springer, Berlin, chap 11, pp 326–344; [ii] Long RB (1995) *Separation processes in waste minimization*. Marcel Dekker, New York, chap 10, pp 288–298; [iii] Krishnan ER (1995) *Recovery of metals from sludges and wastewaters*. Pollution Technology Review, no 207. Noyes Data Corporation, William Andrew, pp 38–46

YG

Element — In → *electrochemistry* the term means a → *galvanic element*. See also → *normal element*.

FS

Elementary electric charge — $e = 1.60217653(14) \times 10^{-19}$ C (best value, 2003). Before 2003 the accepted value was $1.60217733(49) \times 10^{-19}$ C (1986) (→ *coulomb*). See also → *electron*.

Refs.: [i] The National Institute of Standards and Technology (NIST) *Reference on Constants, Units, and Uncertainties* (2003), <http://physics.nist.gov/cuu/constants>; [ii] Mills I (2004) *Chemistry International (IUPAC)* 26(3):17; [iii] Mills I, Cvitas T, Homann K, Kallay N, Kuchitsu K (eds) (1993) *IUPAC quantities, units and symbols in physical chemistry*. Blackwell, Oxford, p 58; [iv] Cardarelli F (1997) *Scientific unit conversion. A practical guide to metrication*. Springer, London

FS

Elementary reaction — A → *chemical reaction* for which no reaction intermediates have been detected or need to be postulated in order to describe the chemical reaction on a molecular scale. An elementary reaction is assumed to occur in a single step and to pass through a single transition state.

Ref.: [i] Muller P (1994) *Pure Appl Chem* 66:1077

WK

Elimination — The reverse of an addition reaction or transformation. In an elimination two groups (called eliminands) are lost most often from two different centers (1/2/elimination or 1/3/elimination, etc.) with concomitant formation of an unsaturation in the molecule (double bond, triple bond) or formation of a new ring. If the groups are lost from a single center (α -elimination, 1/1/elimination) the resulting product is a carbene or a “carbene analogue”.

Ref.: [i] Muller P (1994) *Pure Appl Chem* 66:1077

WK

Elimination voltammetry — This is a mathematical procedure by which the components of the total response in \rightarrow linear scan voltammetry can be separated using a linear combination of total responses corresponding to the same potential, but different \rightarrow scan rates [i, ii]. A condition is that the components have different current-scan rate relationships. The current due to the fast and reversible, \rightarrow diffusion-controlled \rightarrow faradaic reaction is a linear function of the square-root of the scan rate v : $I_r = Y_r \sqrt{v}$, where Y_r is a function of electrode potential, but not of the scan rate. The \rightarrow double layer charging current and a pseudocapacitive current (\rightarrow pseudocapacitance) of the \rightarrow surface redox reaction depend linearly on the scan rate: $I_c = Y_c v$, while the kinetic current of a CE mechanism and the spherical contribution to the diffusion current are independent of the scan rate: $I_k = Y_k$, where Y_c and Y_k are the functions of the potential. Assuming that the total response is a sum of these three components, $I = I_r + I_c + I_k$, a separation of the components is possible when the total current I is recorded employing three different scan rates and measured at a constant potential. The simplest combination of scan rates is v , $v/4$, and $4v$ (e.g., $v = 80$ mV/s, $v/4 = 20$ mV/s, and $4v = 320$ mV/s). The elimination of unwanted components is achieved by calculating the parameters of a linear combination of these three total currents ($F(I) = a_v I_v + a_{v/4} I_{v/4} + a_{4v} I_{4v}$) for which these components are canceled:

$$\begin{aligned} a_v I_v &= a_v Y_r \sqrt{v} + a_v Y_c v + a_v Y_k \\ a_{v/4} I_{v/4} &= a_{v/4} Y_r \sqrt{v}/2 + a_{v/4} Y_c v/4 + a_{v/4} Y_k \\ a_{4v} I_{4v} &= 2a_{4v} Y_r \sqrt{v} + 4a_{4v} Y_c v + a_{4v} Y_k \end{aligned}$$

To eliminate the capacitive and kinetic currents, the sums of the second and the third columns on the right side of this system must be equal to zero. What remains

is a function of the reversible faradaic current:

$$\begin{aligned} (a_v + a_{v/4}/2 + 2a_{4v}) \cdot Y_r \sqrt{v} &= Y_r \sqrt{v} \\ (a_v + a_{v/4}/4 + 4a_{4v}) \cdot Y_c v &= 0 \\ (a_v + a_{v/4} + a_{4v}) \cdot Y_k &= 0 \end{aligned}$$

The solution is $F(I) = 5I_v - 4I_{v/4} - I_{4v}$. A similar procedure was developed for DC \rightarrow polarography on \rightarrow dropping mercury electrode, which is called elimination polarography [iii].

Refs.: [i] Dračka O (1996) *J Electroanal Chem* 402:19; [ii] Trnkova L (2001) *Chem Listy* 95:518; [iii] Dračka O (1986) *Collect Czechoslov Chem Commun* 51:288

MLo

ELISA — Abbreviation for enzyme-linked immunosorbent assay, that is a heterogeneous immunoassay format employing the highly selective binding of antibody to a target molecule (antigen) and enzyme marker. There are a number of different ELISA-formats. All rely on the labeling of an antibody or antigen with an enzyme and determining the activity of the enzyme. The assay contains three basic steps: 1. attachment of the capture immunoreactant to the solid phase, 2. incubation with the test sample, so that the target binds or competes for the binding and, 3. detection of the bound or free fraction using an enzymatic amplification step. Usually antibodies are immobilized onto the well of microtiter plates and the assay is either competitive or noncompetitive. In the competitive ELISA, enzyme-labeled antigen competes with free antigen (the target analyte) for a limited quantity of immobilized antibodies. Alternatively, the antigen is immobilized and the antibody is labeled with the enzyme. In this case the target antigen added together with the labeled antibody competes with the bound antigen for the limited amount of antibody binding sites. The bound enzyme activity is quantified. It is inversely related to the target analyte concentration. Sandwich ELISA belongs to the noncompetitive assay type. In a sandwich ELISA a primary antibody quantitatively binds the antigen and after a washing step an enzyme-labeled secondary antibody is allowed to react with the bound antigen thereby forming a sandwich (immobilized antibody, antigen, secondary antibody) that is detected by measuring the bound enzyme activity. The bound enzyme activity increases with increasing analyte concentration. The sandwich format is restricted to macromolecular analytes. Horseradish peroxidase, alkaline phosphatase, urease, and β -galactosidase are the most common enzyme labels. Most often the formation of colored and fluorescing products of the enzyme reac-

tions are detected. Among the other methods used for quantification is also electrochemistry (\rightarrow immunoassays, electrochemical). Application is in clinical chemistry, food, and environmental control.

Ref.: [i] Tijssen P (1992) *Practice and theory of enzyme immunoassays. Laboratory techniques in biochemistry*, vol. 15. Elsevier, Amsterdam

UW

Ellingham diagrams — are used for graphical codification of the standard \rightarrow Gibbs energy for chemical reactions, presented as a function of temperature. These diagrams are a commonly accepted tool for the analysis of high-temperature \rightarrow corrosion processes involving \rightarrow solid materials, particularly metals or metal compounds, and gaseous components. The analysis is usually based on the approximation that the \rightarrow activities of pure solid reactants and products are equal to unity, whilst the \rightarrow partial pressures of the gaseous phases are determined by the \rightarrow equilibrium expressions. In the case of corrosion reactions, the relative stability of reactants and products can be assessed comparing positions of the lines, showing the standard Gibbs energy (ΔG^\ominus) of the corresponding reactions per mole of the gaseous component (see Fig. 1). The temperature, at which the \rightarrow oxidation or \rightarrow reduction reactions start, is determined considering zero level of the free energy. For the simple reaction $M + y/2X_2 \rightleftharpoons MX_y$, the equilibrium partial pressure of X_2 gas, p_{X_2} , over the M/MX_y mixture is directly related to the standard Gibbs energy normalized to one mole of the gaseous component, as

$$p_{X_2}^{M/MX_y} = \exp \left[\Delta G^\ominus / RT \right] .$$

This equation may also be used for the evaluation of X_2 partial pressure range where the corrosion reaction occurs at a given temperature.

The standard Gibbs energy values, plotted in the Ellingham diagrams, are often calculated from the \rightarrow electromotive force of appropriate \rightarrow galvanic cells, where the \rightarrow potential-determining component is involved in chemical reaction(s) at one \rightarrow electrode. In such cells, the activity of the potential-determining component at another electrode (\rightarrow reference electrode) should be fixed; the calculations are performed using the \rightarrow Nernst equation. One important application of this method includes the analysis of equilibrium dissociation pressures using \rightarrow solid electrolytes.

See also: \rightarrow chemical potential, \rightarrow electrolytic domain, \rightarrow gas titration: coulometric, \rightarrow Wagner equation.

Refs.: [i] Ellingham HJT (1944) *J Soc Chem Ind* 63:125; [ii] Hauffe K (1965) *Oxidation of metals*. Plenum Press, New York; [iii] Khanna AS

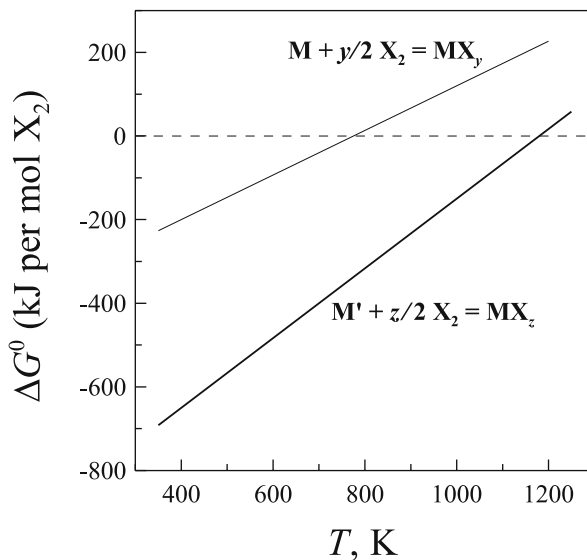

Ellingham diagrams — Figure. Hypothetical Ellingham diagram for two reactions, where the metals M and M' are oxidized by gaseous X_2 . The stability of M is higher than that of M'

(2002) *Introduction to high temperature oxidation and corrosion*. ASM International, Materials Park; [iv] Kröger FA (1964) *The chemistry of imperfect crystals*. North-Holland, Amsterdam

VK

Ellipsometry — Light emitted from a glowing wire (an incandescent or tungsten halogen lamp) or from most other natural as well as artificial sources shows no preferred polarization, i.e., the electric as well as the magnetic vector (both are coupled, their planes of oscillation enclose an angle of 90°) of emitted electromagnetic waves are randomly oriented. When such a beam of light is reflected at a surface, the actual orientation of the electric vector with respect to the plane of reflection (defined by the incoming and the outgoing beam) has considerable influence on the properties of the outgoing wave. This influence can be studied more precisely with polarized light. The latter type of electromagnetic radiation is generated per se, e.g., by certain types of lasers (gas ion) employing windows mounted at the Brewster angle (so-called Brewster windows) at the ends of the plasma tube. From other sources polarized light can be obtained by means of a polarizer. Upon reflection of polarized light both the amplitude (i.e., the magnitude of the electric field vector) and the phase might undergo changes. This depends on the complex refractive index N of the material designated 1 according to

$$N_1 = n_1 - ik_1$$

with the refractive index n_1 and the extinction coefficient k_1 . The refractive index n_1 can be measured using an Abbé refractometer; the extinction coefficient k_1 is related to the absorption coefficient α_1 according to

$$\alpha_1 = 4\pi k_1/\lambda .$$

Further understanding of the interaction is most straightforward when only incident light with its electromagnetic vector parallel to the plane of reflection (E_p) and with its vector perpendicular (E_s) are treated. After superposition of the electric field vectors of these two waves the resulting vector describes a circle provided they were in phase and of the same amplitude. After reflection the mentioned changes result in a superposition wherein the resulting electric field vector describes an ellipse, thus the name of the method. The changes caused by the reflection can be expressed in various ways. A very convenient and popular description using the physical parameters gives the amplitude ratio as

$$\tan \Psi = \frac{|E_p|}{|E_s|} .$$

The difference Δ of the time-independent phases ε of the two components is

$$\Delta = \varepsilon_p - \varepsilon_s .$$

Both parameters are combined in the basic equation of ellipsometry

$$\rho = (\tan \Psi) e^{i\Delta}$$

with $i = \sqrt{-1}$. These parameters are related to the optical properties of the investigated films etc. Textbooks on ellipsometry are available [i–iii]. Thorough reviews of fundamentals including selected applications related to electrochemistry have been published [iv–vii].

An ellipsometer is used to determine the change of the polarization of light effected by reflection at a surface as expressed by ρ . The principal optical elements are polarizer and compensators. The former device has been introduced above. The latter devices (also known as retarders) introduce a defined phase difference between two orthogonal components of a passing wave. The difference may be fixed (e.g., 90° or quarter-wave) or variable. Compensators are manufactured from crystalline birefringent materials like mica, calcite, or quartz. Measurements can be performed at fixed angle of incidence or at variable angles; the used wavelength can be a fixed one or can be variable. In the latter case the instrument is

called a spectroscopic ellipsometer. Instruments can be grouped into two types: compensating and photometric (noncompensating) types. The basic components of a spectroscopic ellipsometer of commercial design of the former type are depicted below.

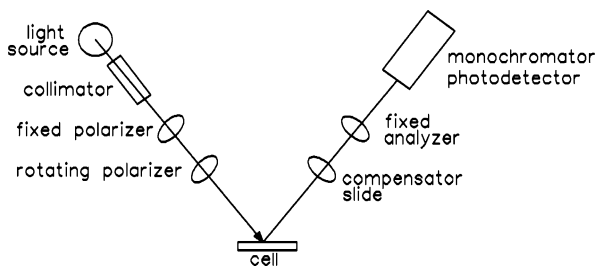

Ellipsometry — Figure. Components of a spectrometric rotating polarizer ellipsometer

In the compensating instrument the phase change caused by the reflection is counteracted by a compensator yielding in effect linearly polarized light. The required information is extracted from the position of the fixed polarizer and the compensator in the incoming beam and the polarizer in the reflected beam. This setup is also called nulling ellipsometer because the correct adjustment of the three optical components resulting in an intensity minimum at the detector is searched. The sensitivity of the photomultipliers frequently used as detectors has to be taken into account. Obviously this approach is too slow for practical application. By adding Faraday modulators in incoming and reflected beam, oscillation of the plane of polarization is possible. Phase-sensitive detection of the signal at the detector with respect to the modulation allows faster determination of the minimum and the relevant position of the corresponding settings of the three optical devices. Further compensation of mechanical adjustment errors is possible by adding two further Faraday modulators operated with a constant current. The technical status of this type of instrument has been reviewed together with further types of instruments [viii]. For further details see [ix].

Refs.: [i] Archer RJ (1968) *Manual on ellipsometry*. Gaertner, Chicago; [ii] Azzam MA, Bashara NM (1977) *Ellipsometry and polarized light*. North-Holland, Amsterdam; [iii] Neal WEJ (1982) *Ellipsometry. Theory and applications*. Plenum, New York; [iv] Muller RH (1991) *Ellipsometry as an in situ probe for the study of electrode processes*. In: Varma R, Selman JR (eds) *Techniques for characterization of electrodes and electrochemical processes*. Wiley, New York, p 31; [v] Plieth W, Kozłowski W, Twomey T (1992) *Reflectance spectroscopy and ellipsometry of organic monolayers*. In: Lipkowski J, Ross PN (eds) *Adsorption of molecules at metal electrodes*. VCH, New York, p 239; [vi] Gottesfeld S

(1989) *Ellipsometry: principles and recent applications in electrochemistry*. In: Bard AJ (ed) *Electroanalytical chemistry*, vol. 15. Marcel Dekker, New York, p 143; [vii] Greef R (1984) *Ellipsometry*. In: White RE, Bockris JO'M, Conway BE, Yeager E (eds) *Comprehensive treatise of electrochemistry*, vol. 8. Plenum Press, New York, p 339; [viii] Muller R (1976) *Surf Sci* 56:19; [ix] Holze R (2008) *Surface and interface analysis: an electrochemists toolbox*. Springer, Berlin

RH

E -log c_i diagram — diagrams where log c_i , i.e., the decadic logarithm of concentration of all species i are plotted versus the redox potential of a solution. The diagrams are similar to the $\rightarrow pH$ -log c_i diagrams. See also $\rightarrow pE$ -log c_i diagrams.

Refs.: [i] Stumm W, Morgan JJ (1996) *Aquatic chemistry*, 3rd edn. Wiley, New York, pp 429; [ii] Butler JN (1998) *Ionic equilibrium*. Wiley, New York, pp 318

FS

Embrittlement — is a process by which various metals, most importantly iron and its alloys (steel), become brittle. Most important is embrittlement caused by insertion of \rightarrow hydrogen (hydrogen embrittlement) following exposure to hydrogen. Embrittlement may result in formation of cracks and subsequent material failure. During acidic \rightarrow corrosion and during exposure of iron and its alloys to gas atmospheres rich in hydrogen (or even water vapor at sufficiently high temperatures) hydrogen atoms diffuse from the surface into the metal. By combination with carbon (present in most iron alloys) methane is formed at grain boundaries, in voids etc. It does not diffuse out of the metal but forms gas pockets of high pressure which in turn initiate cracks. This process is also called hydrogen attack. Embrittlement may also occur at room temperature provided the hydrogen is already present in the metal. Besides steel, aluminum and titanium alloys are most susceptible. In processes involving hydrogen evolution (the presence of molecular or atomic hydrogen) in close contact with steel surface, hydrogen insertion and embrittlement are facilitated. Typical examples are cathodic protection (especially when not properly controlled), phosphating, pickling, and \rightarrow electroplating. Hydrogen embrittlement can also be caused by arc welding when hydrogen is released from moisture in the coating of the welding electrodes. The reaction of steel with hydrogen sulfide (oil and gas industries) may result in the formation of hydrogen and subsequently in hydrogen embrittlement (SSC sulfide stress cracking).

Refs.: [i] Briant CL, Banerji SK (eds) (1983) *Treatise on materials science and technology: embrittlement of engineering alloys*: 25. Academic Press,

New York; [ii] Raymond L (ed) (1988) *Hydrogen embrittlement: prevention and control*. American Society for Testing and Materials, Philadelphia

RH

Emeraldine \rightarrow polyaniline

EMF \rightarrow electromotive force

EM-SPR (Electrochemically modulated surface plasmon resonance) \rightarrow surface plasmon resonance

Emulsions — An emulsion is a dispersion of one liquid in a second immiscible liquid. It is composed of more than two phases of a continuous phase and dispersed phases. It is metastable and tends to be separated gradually into two original phases. Emulsions containing droplets larger than 1 μm exhibit turbidity because of light scattering. In contrast, those with 0.1 μm droplets are semi-transparent or transparent. There are basically two electrochemical approaches; micro-behavior through the knowledge of electrochemically controlled simple oil|water interface [i] and macro-behavior for observing the degree of dispersion and stability [ii]. An electrode in electroactive emulsions causes \rightarrow two-phase electrolysis because the oil and the aqueous phases come in contact with the electrode.

Refs.: [i] Gunaseela K, Romsted LS, Gonzalez-Romer E, Bravo-Diaz C (2004) *Langmuir* 20:3047; [ii] Yoshida J, Chen J, Aoki K (2003) *J Electroanal Chem* 553:117

KA

Enamel electrode — Potentiometric electrode with an enamel layer as ion-sensitive and selective membrane component (see \rightarrow ion-selective electrodes, \rightarrow potentiometry). Enamels showing proton or sodium ion selectivity are composed of 60–75 mol % SiO_2 , 10–25 mol % Na_2O , 0–3 mol % CaO , 0–15 mol % B_2O_3 , and 0–12 mol % Al_2O_3 . Selectivity towards sodium is better than with a glass membrane. The ion-selective enamel is coated on a silver layer serving as electronic conductor supporting itself by insulating enamel-coated steel. Operating conditions range from 0 to 140 $^\circ\text{C}$, from vacuum to 60 bar and from pH 0 to 10. Formation and regeneration occur in particular after exposure to elevated temperature (e.g., in sterilization procedures) much faster than with \rightarrow glass electrodes or \rightarrow ISFETs).

Refs.: [i] Camman K, Galster H (1996) *Das Arbeiten mit ionenselektiven Elektroden*, 3rd edn. Springer; [ii] Endrefß J (2002) *Pharma + Food* 1:36; [iii] anon. (1979) *Chem Ing Tech* 51:A582; [iv] Dittmer H (1979) *Chem Ing Tech* 51:1216

RH

Enantiomer — One of a pair of \rightarrow *molecular entities* which are mirror images of each other and nonsuperimposable.

Ref.: [i] Muller P (1994) *Pure Appl Chem* 66:1077

WK

Encounter complex (or precursor complex) — is a complex of \rightarrow *molecular entities* produced at an \rightarrow *encounter-controlled rate*, and which occurs as an intermediate in a reaction mechanism. If the complex is formed from two molecular entities, it is called an “encounter pair”. A distinction between encounter pairs and (larger) encounter complexes may be relevant in some cases, e.g., for mechanisms involving pre-association.

Ref.: [i] Muller P (1994) *Pure Appl Chem* 66:1077

WK

Encounter-controlled rate — A \rightarrow *reaction rate* corresponding to the rate of encounter of the reacting \rightarrow *molecular entities*. This rate is also known as “diffusion-controlled rate” since rates of encounter are themselves controlled by \rightarrow *diffusion rates* (which in turn depend on the \rightarrow *viscosity* of the medium and the dimensions of the reactant molecular entities). For a bimolecular reaction between solutes in water at 25 °C an encounter-controlled rate is calculated to have a second-order rate constant of about $10^{10} \text{ dm}^3 \text{ mol}^{-1} \text{ s}^{-1}$.

Ref.: [i] Muller P (1994) *Pure Appl Chem* 66:1077

WK

End point (of a titration) — An experimental point in the progress of a titrimetric reaction located where the reaction between the \rightarrow *analyte* and reagent is considered as complete. Ideally, it should be coincident to the \rightarrow *equivalence point* [i].

Ref.: [i] Mendham J, Denney R, Barnes J, Thomas M (2000) *Vogel's quantitative chemical analysis*. Prentice Hall, New Jersey

FG

Endocytosis — A process in which a substance gains entry into a eukaryotic cell without passing through the cell membrane. In this process particles (phagocytosis) or droplets (pinocytosis) are accumulated at the cell surface and enclosed by the cell membrane. The so-formed \rightarrow *vesicles* are then delivered into the cell. Opposite process: \rightarrow *exocytosis*. Endo- and exocytosis are fundamental processes of membrane fusion in living cells. See also \rightarrow *membrane*.

BM

Endosmosis \rightarrow *electroosmosis*

Endotherm galvanic cell — According to the \rightarrow *Gibbs–Helmholtz equation*

$$\Delta G = \Delta H + T \left(\frac{\partial \Delta G}{\partial T} \right)_p$$

$$-\Delta S = \left(\frac{\partial \Delta G}{\partial T} \right)_p$$

Because $\Delta G = -nFE_{\text{cell}}$

$$E_{\text{cell}} = -\frac{\Delta H}{nF} + T \left(\frac{\partial E_{\text{cell}}}{\partial T} \right)_p,$$

where ΔG , ΔH , and ΔS are the \rightarrow *Gibbs energy*, the enthalpy and the entropy change of the reaction, respectively, T is the temperature, p is the pressure, E_{cell} is the \rightarrow *potential* of the cell reaction, F is the \rightarrow *Faraday constant*, and n is the \rightarrow *charge number of the cell reaction*. If $\Delta H > 0$ the reaction is called endothermic. Before 1897 there had not been experimental evidence that endothermic reactions could proceed spontaneously when \rightarrow *Bugarszky* [i] discovered a \rightarrow *galvanic cell* where the cell reaction was endothermic:

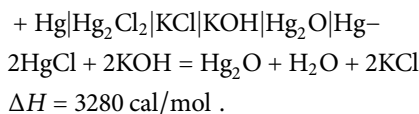

Such cells when $(\partial E_{\text{cell}}/\partial T)_p > 0$ absorb heat from the surroundings if thermostatted or cooling down.

Ref.: [i] Bugarszky I (1897) *Z anorg Chem* 14:145

GI

Energy — In physics the capability or ability to provide work. There are numerous forms of energy including thermal energy (heat), chemical energy, mechanical energy (kinetic energy, potential energy), and electricity (electrical energy). Various forms of energy can be converted into other forms; these processes are governed by the basic laws of \rightarrow *thermodynamics* (conservation of energy, etc.). In most conversion processes a fraction of energy is converted into heat, i.e., into irregular motion of particles and thus lost for practical use in most cases.

RH

Energy density — (specific energy) In the \rightarrow *battery* discipline, energy density is the amount of electrical energy stored in a cell or a battery, per unit of volume or weight. Energy density is divided into (i) theoretical energy density, and (ii) practical (or actual) energy density. Theoretical energy density is the calculated total quantity of electrical energy stored as chemical energy by the active

materials of the cell, and defined by the electrochemical reaction of the cell during discharge, the molecular weight of the active materials, and their density. The theoretical energy density is calculated solely from the thermodynamical data of the active materials (cathode and anode), excluding the electrolyte, current collectors, conductive additives, binders, and packaging. Practical (or actual) energy density is the actual measured amount of electrical energy delivered by a specific cell or battery during discharge at certain conditions. It is measured as the integration of power with time over the course of the cell discharge. The measured (actual) energy density is dependent on numerous variables, such as temperature, current density, manufacturing practices, materials purity, etc. The practical energy density is always lower than the theoretical, and usually amounts to around one half to one fifth of the theoretical value.

Energy density is expressed in terms of watt-hour per unit mass (usually kilogram) or watt-hour per unit volume (usually liter), and termed “gravimetric energy density”, and “volumetric energy density”, respectively.

Refs.: [i] Crompton TR (2000) *Battery reference book*, 3rd edn. Newnes, Oxford, pp 42–44; [ii] Berndt D (2003) *Fundamentals and theory, running techniques, applications and outlook: traction batteries, stationary batteries and charging methods*. In: Kiehne HA (ed) *Battery technology handbook*, 2nd edn. Marcel Dekker, New York, p 44

YG

Energy profile → Gibbs energy diagram

Energy storage — Depending on the type of energy considered numerous possibilities to store energy are feasible. Thermal energy can be stored in heated matter, chemical energy is stored in chemical compounds which deliver the stored energy during chemical transformations. Mechanical energy can be stored as kinetic energy in devices like, e.g., flywheels, as potential energy in pump storage power stations. Electrical energy can be stored in condensers, as space charge in electrets, or electromagnetic coils. The storage capacity of the former devices is too low for general applications beyond use in electronics (see → *electrolytic capacitor*) and as booster devices. The energy of the magnetic systems can only be recovered as heat. Storage of electrical energy is feasible generally only after transformation into other forms of energy like, e.g., chemical energy in → *secondary cells* (→ *accumulators*) or regenerative → *fuel cells* (i.e., fuel cells operating alternatively as → *electrolyzers*).

RH

Ensemble averaging → digital filter

Enthalpy — The main variables in the thermodynamic treatment of an isolated system can be defined as the ‘internal energy’ U of the system, its pressure, volume, and temperature, and the amount of heat supplied or removed. In general, if dq is the amount of heat supplied in an incremental form, dU the corresponding change in internal energy and $p dV$ the external work done by the system, then conservation of energy demands that $dq = dU + p dV$. This equation defines the first law of → *thermodynamics*. The internal energy U is, in general, a function only of the temperature and pressure of the system and is termed a state function. However, q is not a state function (see → *Entropy*). State functions have the property that no matter how the state is realized, provided that the conditions of temperature, pressure, and quantity of material are the same, then U will also be the same. For convenience in describing systems at constant pressure, the quantity ‘Enthalpy’ has been introduced and is defined as $H = U + pV$. The significance of H is that if we consider two systems at the same pressure but differing temperatures and volumes, then the difference in enthalpy between them, $\Delta H = H_2 - H_1 = U_2 - U_1 + p(V_2 - V_1)$. However, we can see by integrating the conservation of energy formula that $\Delta q = \Delta U + p\Delta V$ at constant pressure, from which we see that under conditions of constant pressure $\Delta H = \Delta q$. We can thus write the molar specific heat at constant pressure $C_p = \left(\frac{\partial H}{\partial T}\right)_p$ in contrast to the specific heat at constant volume $C_v = \left(\frac{\partial U}{\partial T}\right)_v$. Further progress can be made by employing the relationship $(dq/T)_{\text{rev}} = dS$, where S is the → *entropy*. Then we can write $T dS = dU + p dV$ and $dU = T dS - p dV$. From this it is clear that $dH = dU + p dV + V dp = T dS + V dp$. The analysis above is entirely adequate for an isolated system able to do only work of expansion and which contains either a single substance or a set of noninteracting substances. If we wish to consider a system which is open, or whose composition may vary in time, we must consider the dependence of U and H on the number of moles of each component. For H , we have $H = H(S, p, n_1 \dots n_k)$, and we must have: $dH = T dS + V + \sum_{i=1}^{i=k} \left(\frac{\partial H}{\partial n_i}\right)_{S,p,n_j} dn_i$. It is easily shown that the differentials in the sum are the → *chemical potential* introduced by → *Gibbs, J.W.* and defined as $\mu_i = \left(\frac{\partial G}{\partial n_i}\right)_{T,p,n_j}$ and so we can write finally: $dH = T dS + V dp + \sum_{i=1}^{i=k} \mu_i dn_i$.

Ref.: [i] Denbigh KG (1987) *Principles of chemical equilibrium*, 4th edn. Cambridge University Press, Cambridge

AH

Enthalpy of activation $\Delta^\ddagger H$ (standard enthalpy of activation $\Delta^\ddagger H^\ominus$) (kJ mol⁻¹) — The standard enthalpy difference between the transition state and the ground state of the reactants at the same temperature and pressure. It is related to the temperature coefficient of the rate constant according to the equation:

$$\begin{aligned}\Delta^\ddagger H &= RT^2(\partial \ln k / \partial T)_p - RT = E_a - RT \\ &= -R[\partial \ln(k/T) / \partial (1/T)]_p,\end{aligned}$$

where E_a is the \rightarrow *activation energy*, providing that the \rightarrow *rate constants* for reactions other than first-order reactions are expressed in temperature-independent concentration units (e.g., mol dm⁻³, measured at a fixed temperature and pressure). If $\ln k$ is expressed as

$$\ln k = (a/T) + b + c \ln T + dT,$$

then

$$\Delta^\ddagger H = -aR + (c-1)RT + dRT^2.$$

If enthalpy of activation and \rightarrow *entropy of activation* are assumed to be temperature independent, then

$$\Delta^\ddagger H = -aR.$$

If the concentration units are mol dm⁻³, the true and apparent enthalpies of activation differ by $(n-1)/(\alpha RT^2)$, where n is the \rightarrow *order of reaction* and α — the thermal expansivity. See also \rightarrow *Gibbs energy of activation*.

Ref.: [i] Muller P (1994) *Pure Appl Chem* 66:1077

WK

Entropy — Entropy arose out of an attempt to understand why certain processes were never observed to take place in adiabatic systems; we can heat water up by driving a paddle by a weight that descends to the floor, but we never observe the water cooling spontaneously and the weight rising. In a similar way, if we place two copper blocks of the same mass but different temperatures in thermal contact, the final temperature will be the mean of the initial temperatures; however, we never observe that the two blocks spontaneously attain measurably different temperatures whilst remaining in thermal contact. To describe this impossibility, it must be possible to identify a state function for the system that has certain bounds on its behavior, and after much discussion in the nineteenth century, it was realized that one of the key concepts was \rightarrow *'reversibility'*, a reversible process being one carried out such that at all times the system remains in equilibrium. For example, if a system is heated sufficiently slowly, then no macroscopic thermal gradients

will be set up. The heat required in a reversible process can be written $(dq)_{\text{rev}}$ and \rightarrow *Clausius* discovered that if this differential is divided by the temperature of the system, T , then the result is the change of a state function: $dS = (dq/T)_{\text{rev}}$ where S is termed the entropy, a word derived from the Greek word for transformation. For an isolated system, where no heat exchange with the surroundings is permitted, Clausius showed that $dS \geq 0$. Thus, for the copper blocks above, the change in entropy if one block cools by an amount a and the other heats up by the same amount is $-\int_{T-a}^T \frac{C_p dT}{T} + \int_T^{T+a} \frac{C_p dT}{T}$ which is evidently negative since C_p is essentially constant if a is sufficiently small. Similarly, if a copper block, initially at temperature $T_>$ is placed in contact with a thermal bath at a fixed temperature then $dS = -\int_{T_>}^{T_{\text{bath}}} \frac{dq}{T} + \frac{1}{T_{\text{bath}}} \int_{T_{\text{bath}}}^{T_>} dq$, which remains positive if and only if $T_> \geq T_{\text{bath}}$.

The above definitions reflect the Clausius view of the origin of entropy; at the beginning of the twentieth century a reformulation of thermodynamics by \rightarrow *Born* and *Carathéodory* showed firstly that the formulation of the second law of \rightarrow *thermodynamics* requires a consideration of the heat and work relationships of at least two bodies, as implicitly discussed above, and that entropy arises in this formulation from the search for an integrating factor for the overall change in heat, dq when the simultaneous changes in two bodies are considered. The Born–Carathéodory formulation then leads naturally to the restriction that only certain changes of state are possible under adiabatic conditions.

A more fundamental understanding of entropy derives from the work of \rightarrow *Boltzmann* towards the end of the nineteenth century. Boltzmann suggested that in any system, there would be a large number of possible arrangements of molecules corresponding to any particular fixed energy, volume, and number of particles of each component. Given that there is no reason to favor any one of these arrangements over others, then under conditions of constant energy, volume, and composition, the state with the greatest number of possible arrangements or 'complexions' available will be that most likely to be realized. If this number is denoted by Ω , then Boltzmann suggested the relationship $S = k \ln \Omega$, where k is now recognized as a fundamental constant, termed \rightarrow *Boltzmann constant*. A simple example of a calculation using Boltzmann's formula is the entropy of solid CO at 0 K. Because the dipole moment of CO is so small, when the substance solidifies the CO molecules can have either orientation CO or OC in the crystal. Since each molecule is independent, clearly per mole $\Omega = 2^{N_A}$ where N_A

is the Avagadro constant. The entropy 'frozen in' to the crystal is then $S = k \ln 2^{N_A} = R \ln 2 = 1.38 \text{ J K}^{-1}$; this is actually slightly larger than the experimental value, but clearly accounts for the deviation from the expected third-law value.

Entropy effects also play a major role in \rightarrow solvation phenomena, especially in such areas as \rightarrow polyelectrolyte interactions in aqueous solutions, protein folding effects, and \rightarrow micelle formation and structures, where the main driving force is the gain in entropy on micellar formation due to loss of highly structured water (\rightarrow Iceberg structure) surrounding the individual amphiphiles. Entropy effects also dominate the dissociation of many weak organic acids in solution and the well-known chelate effect in inorganic chemistry.

Refs.: [i] Denbigh KG (1987) *Principles of chemical equilibrium*, 4th edn. Cambridge University Press, New York; [ii] Radeva T (2001) *Physical chemistry of polyelectrolytes*. Marcel Dekker, New York; [iii] Ben-Naim A (1992) *Statistical thermodynamics for chemists and biologists*. Plenum Press, London

AH

Entropy of activation $\Delta^\ddagger S$ (standard entropy of activation $\Delta^\ddagger S^\ominus$) ($\text{J mol}^{-1} \text{K}^{-1}$) — The standard entropy difference between the \rightarrow transition state and the ground state of the reactants, at the same temperature and pressure. It is related to the \rightarrow Gibbs energy of activation and \rightarrow enthalpy of activation by the equations

$$\begin{aligned}\Delta^\ddagger S &= (\Delta^\ddagger H - \Delta^\ddagger G)/T \\ &= \Delta^\ddagger H/T - R \ln(k_B/T) + R \ln(k/T)\end{aligned}$$

or, if $\ln k$ is expressed as

$$\begin{aligned}\ln k &= a/T + b + c \ln T + dT \\ \Delta^\ddagger S &= R[b - \ln(k_B/h) + (c - 1)(1 + \ln T) + 2dT]\end{aligned}$$

provided that rate constants for reactions other than first-order reactions are expressed in temperature-independent concentration units (e.g., mol dm^{-3} , measured at a fixed temperature and pressure). The numerical value of ASS depends on the standard state (and therefore on the concentration units selected). If entropy of activation and enthalpy of activation are assumed to be temperature-independent,

$$\Delta^\ddagger S = R[b - \ln(k_B/h)].$$

Strictly speaking, the quantity defined is the entropy of activation at constant pressure from which the entropy of activation at constant volume can be deduced. The information represented by the entropy of activation may

alternatively be conveyed by the pre-exponential factor A (\rightarrow Arrhenius equation). See also \rightarrow energy of activation.

Ref.: [i] Muller P (1994) *Pure Appl Chem* 66:1077

WK

Entropy of transport \rightarrow heat of transport

EnViro[®] cell — Electrochemical cell employing \rightarrow packed-bed electrodes (mostly of graphite or other carbonaceous materials in general-purpose cells or of metal particles when only a single metal is deposited) as cathode and an \rightarrow ion-exchange membrane as separator. The anode can be of any suitable material. EnViro cells are employed in wastewater treatment for the removal of cations from effluents. The strong turbulence caused by the packed-bed electrodes results in efficient \rightarrow mass transport of metal cations yielding high metal deposition rates even at low metal cation concentrations. The cross section of the cell is small at the entrance and large at the exit resulting in low flow rates of the solution enabling metal cations to reach the packed-bed particles even at lowest concentrations. Reductions in metal concentrations by up to 4 orders of magnitude have been achieved. Metal recovery is possible by either simple removal of the bed particles (in case particles of the same metal which has been deposited have been used) or by treatment with suitable acids or by switching the packed bed to a suitable positive electrode potential. Anodic oxidation of organic pollutants is also possible.

Ref.: [i] Kreysa G (1983) *Chem Ing Tech* 55:23

RH

Enzyme electrodes — An enzyme electrode consists of an enzyme immobilized on an electrode, the function of the enzyme electrode being essentially connected with the catalytic activity of the immobilized enzyme. The electrochemical response of an enzyme electrode can be based either on the enzymatic generation of electroactive species or on the electrochemical communication of the enzyme with the electrode.

Enzyme electrodes play a vital role in the operation of \rightarrow biosensor and \rightarrow biofuel cells. The term 'enzyme electrode' was coined by Clark and Lyons after their first demonstration of a \rightarrow glucose sensor in which glucose oxidase was entrapped at a \rightarrow Clark oxygen electrode using a dialysis membrane. The decrease in measured oxygen concentration was proportional to the glucose concentration.

For the repeated use of enzymes in such an analytical device, numerous techniques for enzyme immobilization including entrapment in hydrogels (membrane

Enzyme electrodes — Table 1. Types of enzyme electrodes

Analytes	Enzyme classes	Electrochemical transducer and indicated species or effects		
		Voltammetric and coulometric electrodes;	Potentiometric electrodes/ISFETs	Capacitive electrodes
		(Current, Charge)	(Potential)	(Capacitance)
Enzyme substrates Activators Inhibitors Coenzymes Cofactors Prosthetic groups Enzymes	Oxidoreductases <ul style="list-style-type: none"> Dehydrogenases Oxidases Peroxidases Electron transferases Hydrolases: <ul style="list-style-type: none"> Proteases Esterases Glycosidases Transferases: <ul style="list-style-type: none"> Kinases Transaminases 	NAD(P)H O ₂ H ₂ H ₂ O ₂ Mediators/redox dyes Phenolics/quinones Redox proteins Prosthetic groups Thiols/disulfides	H ⁺ HCO ₃ ⁻ NH ₃ NH ₄ ⁺ L ⁻ F ⁻	Binding effect Substrate degradation Protein digestion

electrode), electropolymers (\rightarrow *enzyme immobilization, electrochemically controlled*), in the bulk of an electrode (\rightarrow *carbon paste electrode*) and on electrode surfaces have been developed. The layer of immobilized enzyme is characterized by an enzyme loading reflecting the interplay of enzyme kinetics and mass transfer.

The loading is crucial for the response characteristics and the stability of the enzyme electrode. The choice of the enzyme determines the chemical selectivity of the measurement due to the specificity of the signal-producing interaction of the enzyme with the analyte. The selection of the indicator electrode is largely determined by the species involved in the enzyme reaction.

Typically the reaction is monitored by measuring the rate of formation of a product or disappearance of a reactant. If the product or reactant is electroactive, amperometric and coulometric electrodes are used to monitor the reaction directly. The enzymes used here are mainly oxidoreductases (see Table 1) and oxygen and H₂O₂, which are the cosubstrate and product of oxidases, as well as NAD(P)H, the cosubstrates of pyridine nucleotide-dependent dehydrogenases are indicated. Some hydrolases, e.g., β -galactosidase and alkaline phosphatase generate also electroactive products. Otherwise potentiometric transducers are monitoring pH-change and the formation of NH₄⁺ or I⁻. A prominent example is the urea electrode comprising urease and a glass electrode. Other pH-sensitive transducers are metal oxide electrodes, e.g., antimony oxide and palladium oxide, and ion-sensitive field effect transistors. Modification of the gate of the latter with urease or β -lactamase led to ENFETs (enzyme-modified field-effect transistors) for urea and penicillin.

The most common enzyme electrodes involve the amperometric monitoring of oxygen consumption or formation of hydrogen peroxide using a platinum electrode. For example, glucose, lactate, cholesterol, and glutamate with glucose oxidase, lactate oxidase, cholesterol oxidase, and glutamate oxidase, respectively. However, varying O₂-concentrations in the sample and interferences from electroactive sample components may restrict the quality of measurement. This is partly overcome by using artificial electron transfer mediators (\rightarrow *redox mediators*). These mediators are used as diffusional mediators or coupled to the electrode surface (\rightarrow *chemically modified electrode*). Further progress was achieved with \rightarrow *conducting polymers*, flexible polymers onto which mediating functionalities were covalently bound, and direct coupling of the mediators to the enzyme (the so-called wired enzymes).

A virtually interference-free and reagentless approach is immobilizing the redox enzyme on a suitable electrode surface in such a way that the protein-integrated redox site can directly exchange electrons with the electrode (enzymes with direct electron transfer contact).

Under appropriate conditions these enzyme electrodes are capable of determining not only substrates, but also co-substrates, effectors, prosthetic groups and coenzymes, and enzyme activities via substrate determination.

It is also possible to couple several enzymes into the same sensor (Table 2) to measure a broader range of substrates and to improve the sensor performance.

Three processes shall be regarded as for the theoretical description of an amperometric enzyme electrode:

Enzyme electrodes — Table 2. Coupling principles for design of sensor performance

Principle of coupling	Reaction	Effect on performance	Example
Sequential reactions	Linear sequence	Expansion of analyte spectrum; Specificity	Lactose with β -galactosidase and GOD
	Accumulation/enzymatic stripping	Expansion of analyte spectrum; Specificity	NADH with glycerol dehydrogenase and lactate dehydrogenase
	Cascade	Expansion of analyte spectrum; Specificity	AMP with glycogenphosphorylase, alkaline phosphatase, and GOD
Parallel reactions	Competition	Expansion of analyte spectrum; Specificity	Glucose measurement with low interference of ascorbate using ascorbate oxidase and GOD
	Elimination	Specificity	
	Anti-interference	Linear working range	
Cyclic reactions	Mono-, multiple and non-linear cycle	Enhanced sensitivity	Dopamine with tyrosinase and glucose dehydrogenase

the electrochemical reaction (\rightarrow *electrode reaction*), the enzyme-catalyzed reaction, and the \rightarrow *mass transport*. Provided the electrochemical reaction is sufficiently fast, in a stirred solution the response of an enzyme electrode may be limited by the enzyme kinetics (i) or is controlled by diffusion (ii). For these limiting cases the steady-state response of an amperometric mono-enzyme electrode I_{st} is given by

$$(i) I_{st} = \frac{nFAV_{max}}{K_M} S_0 \quad (\text{for } S < K_M)$$

and

$$(ii) I_{st} = \frac{nFAD_s}{d} S_0$$

with n the number of electrons, F the \rightarrow *Faraday constant*, V_{max} maximum conversion rate of the substrate S , and K_M the substrate concentration, where the substrate conversion rate is half of the maximum. D_s diffusion coefficient of the substrate, A the electrode area, and d the thickness of the enzyme layer.

Increase of the load of enzyme of a highly active enzyme shifts the kinetically controlled enzyme electrode to diffusional limitation. Since diffusion-limiting effects are associated with the immobilization, they may be manipulated by the procedure of coupling an enzyme to the electrode.

Depending on the target analyte and the application one or the other limiting case is desired. Multiple substrate analysis over a long time period, i.e., high long-term stability, requires diffusional limitation. A typical example is a glucose sensor for an autoanalyzer in a clinical laboratory.

Kinetic control is essential if effectors of enzymes are to be measured, for example, nerve agents which are inhibitors of acetylcholine esterase.

The most relevant fields of practical application of enzyme electrodes are medical diagnostics, followed by process control, food analysis, and environmental monitoring.

Refs.: [i] Clark LC, Lyons C (1962) *Ann NY Acad Sci* 102:29; [ii] Turner APF, Karube I, Wilson GS (1987) *Biosensors: fundamentals and applications*. Oxford University Press, Oxford; [iii] Scheller FS, Schubert F (1992) *Biosensors*. Elsevier, Amsterdam; [iv] Heller A (1990) *Acc Chem Res* 23:128; [v] Scheller F, Wollenberger U (2002) *Enzyme electrodes*. In: Bard AJ, Stratmann M, Wilson GS (eds) *Bioelectrochemistry*. Encyclopedia of electrochemistry, vol. 9. Wiley-VCH, Weinheim; [vi] Scheller F, Lisdat F, Wollenberger U (2005) *Application of electrically contacted enzymes for biosensors*. In: Willner I, Katz E (eds) *Bioelectronics: from theory to applications*. Wiley-VCH, Weinheim; [vii] Cass AEG (ed) (1990) *Biosensors a practical approach*. Oxford University Press, Oxford

UW

Enzyme immobilization, electrochemically controlled

— The reproducible immobilization of enzymes as biorecognition elements in \rightarrow *biosensors* on suitable transducer surfaces is of great importance for the sensor properties. Moreover, the ability to control the sensor fabrication process is a fundamental prerequisite for a potential commercialization of a biosensor architecture. In order to increase reproducibility non-manual procedures for enzyme immobilization were proposed based on electrochemically controlled immobilization strategies such as: i) electrophoretic accumulation of enzymes in front of an electrode surface followed by crosslinking [i], ii) electrochemically induced polymerization of conducting or insulating polymer films at the electrode surface leading to an entrapment of enzymes within the growing polymer film [ii, iii] electrochemically induced modulation of the solubility of polymers in the vicinity of an electrode surface by means of elec-

trochemically induced pH modulation leading to the entrapment of enzymes within the precipitating polymer film [iii, iv]. The principal idea is based on the initiation of a reaction or reaction sequence by application of a suitable electrode potential in an amperometric or voltammetric experiment spatially confined to the diffusion layer in front of the electrode surface. Thus, by controlling a number of influencing parameters such as temperature, ionic strength, pH value, and concentrations of the enzyme, polymer, or monomer a highly reproducible formation of an immobilization layer is possible. During electrophoretic accumulation the pH value is adjusted to obtain charged protein molecules which are migrating in an electric field towards the electrode surface. After a predefined accumulation time at a defined concentration and applied potential the electrode is removed from the electrolyte and placed in a solution containing bifunctional crosslinking agents. The crosslinking of the accumulated enzymes leads to an insoluble protein layer on top of the electrode surface. Entrapment of enzymes within growing conducting or nonconducting polymer films involves electrochemically induced formation of polymer precursors, e.g., by oxidation of suitable monomers such as pyrrole, aniline, phenol, or thiophene yielding the related radical cations within the diffusion zone in front of the electrode. Radical recombination formation of the related oligomers and electrochemical oxidation of these oligomers lead to further growth of the polymer chain until finally an insoluble polymer chain is formed. Concomitant with the precipitation of the formed polymer chain and its oxidation under formation of a charged polymer backbone on the electrode surface the enzyme is entrapped within the growing polymer network. This approach has been widely investigated for the formation of conducting polymer-based

biosensors, however, there are limitations imposed by the solubility of the monomers in aqueous solution, the often hydrophobic polymer films, and the high potentials necessary for the radical formation. A third approach aiming to overcome these limitations is based on electrodeposition polymers which consists of polycationic or polyanionic micelles emulgated in aqueous solution. The charge at the polymer backbone is caused by protonated amino functions or deprotonated carboxylic acid side chains and can thus be modulated by pH changes. Electrochemically induced water oxidation or water reduction at the electrode surface leads to the liberation of OH^- or H_3O^+ and consequently to a spatially confined change of the pH value. The solubility of polymer micelles in close vicinity to the electrode surface is changed and the polymer chains are precipitating on the electrode surface simultaneously entrapping an enzyme present in the solution. As a matter of fact, the polymer film thickness can be easily adjusted via the electrochemical induced change of the pH value.

Refs.: [i] Strike DJ, De Rooij NF, Koudelka-Hep M (1993) *Sens Actuators B* 13–14:61; [ii] Schuhmann W (2002) *Rev Molecular Biotechnol* 82:425 (see also references in “Biosensors, conducting polymer based”); [iii] a) Kurzawa C, Hengstenberg A, Schuhmann W (2002) *Anal Chem* 74:355; b) Ngounou B, Neugebauer S, Frodl A, Reiter S, Schuhmann W (2004) *Electrochim Acta* 49:3855

WSchu

Enzyme linked immunosorbent assay → ELISA

E-pH diagram → potential-pH diagram

Epitaxial metal deposition — In an epitaxial deposition the crystal lattice of the substrate is continued in the deposit. In homoepitaxy the substrate and the growing film

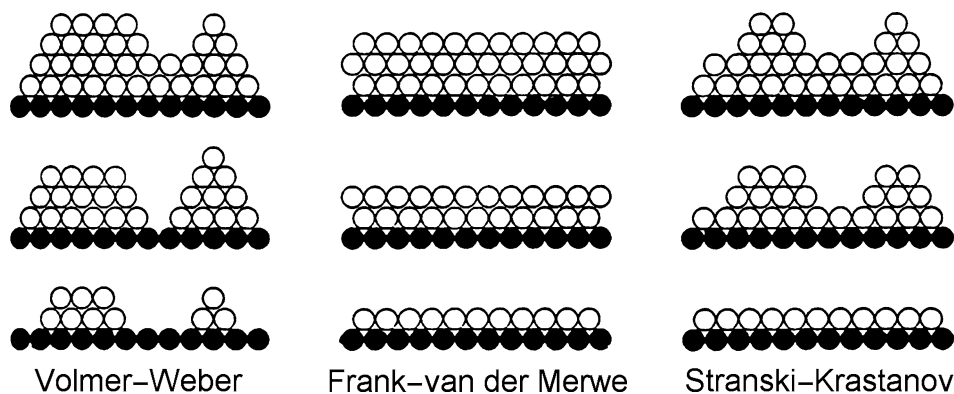

Epitaxial metal deposition — Figure. Schematic representation of heteroepitaxial growth modes

consist of the same material, in heteroepitaxy they are different.

The growth mode for a heteroepitaxial metal deposition of M on a substrate S is governed by the relative magnitudes of the binding energy between the \rightarrow *adatom* of the growing film and the substrate, $\Psi(M_{\text{ad}} - S)$, and the binding energy between M_{ad} and the bulk phase of M , $\Psi(M_{\text{ad}} - M)$. A further important parameter is the crystallographic misfit between S and M . Three important growth modes can be distinguished: Volmer–Weber, Stranski–Krastanov, and Frank–van der Merwe (see Fig. 1) (see also \rightarrow *Volmer*, \rightarrow *Stranski*).

The Volmer–Weber growth mode is characterized by the fact that the binding energy of the adatoms, M_{ad} , on the substrate, S , is smaller than the binding energy of M_{ad} on pure M . As a consequence, the formation of the bulk phase of M occurs via the formation of 3D islands. The Frank–van der Merwe mode is a layer-by-layer growth mode and occurs for the case $\Psi(M_{\text{ad}} - S) > \Psi(M_{\text{ad}} - M)$ and a small crystallographic misfit. For $\Psi(M_{\text{ad}} - S) > \Psi(M_{\text{ad}} - M)$ and a considerable crystallographic misfit the growth occurs via the Stranski–Krastanov mode. It is characterized by a 3D island growth on top of a strained 2D monolayer.

Refs.: [i] Budevski E, Staikov G, Lorenz WJ (1996) *Electrochemical phase formation and growth. An introduction to initial stages of metal deposition*. VCH, Weinheim, pp 4–6; [ii] Watanabe T (2004) *Nano-plating. Microstructure control theory of plated film and data base of plated film microstructure*. Elsevier, Amsterdam, pp 97–106

AB

EQCM \rightarrow *electrochemical quartz crystal microbalance*

EQCN \rightarrow *electrochemical quartz crystal microbalance*

Equilibrium — A system has reached equilibrium when the properties of the system (such as volume, pressure, color, composition, etc.) no longer change with time. For a chemical equilibrium (involving one or more reversible chemical reactions), the forward and reverse directions of each reaction proceed at equal rates and the system has reached a state of minimum \rightarrow *Gibbs energy*. See also \rightarrow *reversibility*.

DT

Acid–base equilibrium — Using the Brønsted–Lowry definition (see \rightarrow *acid–base theories*), an acid–base reaction involves a \rightarrow *proton transfer* from an acid to a base. Removal of a proton from an acid forms its conjugate base, while addition of a proton to a base forms its conjugate acid. Acid–base equilibrium is achieved when the \rightarrow *activity* (or \rightarrow *concentration*) of each conjugate

acid and conjugate base in solution becomes constant, at which point the \rightarrow *pH* is also constant. In aqueous solutions, typical proton transfer reactions are very rapid and acid–base equilibrium is quickly reached.

DT

Equilibrium constant — For a general chemical reaction such as

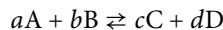

the thermodynamic equilibrium constant K_a is defined as

$$K_a = \frac{a_C^c a_D^d}{a_A^a a_B^b} = \frac{\gamma_C^c \gamma_D^d [C]^c [D]^d}{\gamma_A^a \gamma_B^b [A]^a [B]^b},$$

where a_i represents the \rightarrow *activity* of species i , γ_i the \rightarrow *activity coefficient* of species i , and $[i]$ the \rightarrow *concentration* of species i . The equilibrium constant in terms of activities is a dimensionless thermodynamic quantity, depending only on temperature, and is related to the standard \rightarrow *Gibbs energy change* (ΔG^\ominus) for the reaction by

$$\Delta G^\ominus = -RT \ln K_a,$$

where R and T are the \rightarrow *gas constant* and absolute temperature, respectively. In some cases, a \rightarrow *conditional (or apparent) equilibrium constant* (K_c) expressed in terms of concentrations (rather than activities) may be preferred, defined as

$$K_c = \frac{[C]^c [D]^d}{[A]^a [B]^b}.$$

Such constants depend not only on temperature but also on the \rightarrow *ionic strength* of the solution, have units of concentration (e.g., molarity) raised to some power, and are related to the activity based equilibrium constant K_a by the expression

$$K_c = \frac{\gamma_A^a \gamma_B^b}{\gamma_C^c \gamma_D^d} K_a.$$

DT

Dynamic equilibrium — A dynamic equilibrium is reached when you have a reversible reaction taking place in a closed system. At equilibrium, the activities of all species participating in the reaction remain constant, although the reactions are still continuing. This is because the rates of the forward and the reverse reactions are equal.

DT

Electrochemical equilibrium — An \rightarrow electrochemical cell consists of at least two \rightarrow electrodes at which particular \rightarrow half-cell reactions are occurring, for example

cathode:

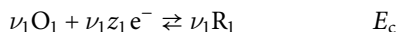

anode:

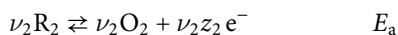

net cell reaction:

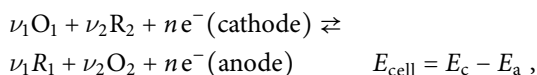

where E_c , E_a , and E_{cell} are the \rightarrow cathode, \rightarrow anode and \rightarrow cell potentials, respectively, $n = \nu_1 z_1 = \nu_2 z_2$ is the electron charge number, z_1 and z_2 are the ion charge numbers, and ν_1 and ν_2 are the stoichiometric numbers for the net cell reaction, R is the reduced form, and O is the oxidized form. The cell is at electrochemical equilibrium when there is no current flow through the cell (for example, at \rightarrow open circuit or with a high impedance voltmeter attached), and the cell voltage and the cell composition (activities of all species) remain constant. Note that this is rigorously true only for the (hypothetical) cell having no \rightarrow liquid junction and no parasitic reactions (e.g., no direct reaction between O_1 and R_2 in the electrolyte). However, it is a useful concept even for cells that do have one or more liquid junctions and/or parasitic reactions, as long as compositional changes in the cell due to such processes are negligibly small over the time scale of interest.

Electrochemical equilibrium is established at each interface of the cell when the \rightarrow electrochemical potentials of the common components of the two phases (α and β) forming the interface are equal, that is $\bar{\mu}_i^\alpha = \bar{\mu}_i^\beta$, and the electrochemical free energy change ($\Delta\bar{G}$) for the process occurring at the interface is zero. For the net cell reaction given above, such considerations lead to an expression for the electrochemical equilibrium constant \bar{K}_a given by [i]

$$\bar{K}_a = \exp \left\{ \frac{nFE_{\text{cell}}}{RT} \right\} \frac{a_{\text{R}_1}^{\nu_1} a_{\text{O}_2}^{\nu_2}}{a_{\text{O}_1}^{\nu_1} a_{\text{R}_2}^{\nu_2}}.$$

Note that there are virtually an infinite number of combinations of cell voltage and cell composition (the activity term) that satisfy this equation. Thus, there are an infinite number of electrochemical equilibrium states, each corresponding to a different cell voltage [i].

If the cell is completely discharged such that E_{cell} goes to zero, then the cell is at chemical equilibrium and the above equation collapses to

$$\bar{K}_a = \frac{a_{\text{R}_1}^{\nu_1} a_{\text{O}_2}^{\nu_2}}{a_{\text{O}_1}^{\nu_1} a_{\text{R}_2}^{\nu_2}} = K_a.$$

Thus, the numerical value of the electrochemical equilibrium constant for a cell in which a net particular reaction occurs is identical to the chemical equilibrium constant K_a for that reaction (see \rightarrow redox equilibrium) [i].

Ref.: [i] Oldham KB, Myland JC (1994) *Fundamentals of electrochemical science*, 1st edn. Academic Press, San Diego, pp 71–74

DT

Redox equilibrium — An equilibrium system may involve one or more \rightarrow redox reactions taking place in solution. Such reactions may be written as a combination of individual half reactions (\rightarrow half-cell reactions), for example

half reaction 1 (reduction):

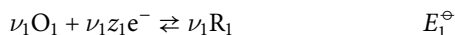

half reaction 2 (oxidation):

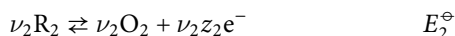

net reaction:

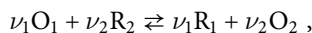

where O and R are the oxidized and reduced forms, respectively, of species 1 and 2 and E_1^\ominus , E_2^\ominus are the \rightarrow standard potentials of the respective half reactions that involve the transfer of $n = \nu_1 z_1 = \nu_2 z_2$ electrons. The \rightarrow equilibrium constant for the net reaction is related to the standard potentials of the individual half reactions by [i]

$$K_a = \frac{a_{\text{R}_1}^{\nu_1} a_{\text{O}_2}^{\nu_2}}{a_{\text{O}_1}^{\nu_1} a_{\text{R}_2}^{\nu_2}} = \exp \left\{ \frac{nF}{RT} (E_1^\ominus - E_2^\ominus) \right\}.$$

Some redox reactions involve additional species (e.g., H^+ , H_2O , or Cl^-) that do not undergo change in oxidation state.

Ref.: [i] Oldham KB, Myland JC (1994) *Fundamentals of electrochemical science*, 1st edn. Academic Press, San Diego, p 74

DT

Equilibrium electrode potential \rightarrow potential

Equilibrium form of crystals and droplets

Liquid droplets — The condition for the \rightarrow equilibrium form of a liquid droplet formed on a solid foreign substrate (the working electrode) is obtained from

the requirement for a minimum of the total free surface and edge energies (see → *surface energy*) at a constant volume, $d\Phi(\gamma, \kappa) = 0$, $dV = 0$ and results in [i–v]

E

$$\gamma_{23} - \gamma_{12} + \gamma_{13} \cos \theta + \frac{\kappa}{R \sin \theta} = 0. \quad (1)$$

In Eq. (1) R is the radius of the homogeneously formed sphere, θ is the → *wetting angle*, γ_{12} , γ_{13} , and γ_{23} are the specific free surface energies at the solution|substrate, solution|droplet and substrate|droplet interface boundaries, respectively. κ is the specific free line energy (or line tension) at the droplet periphery and could be either zero or a positive, or a negative quantity [v, vii–x].

Equation (1) tells us that for sufficiently small droplets the wetting angle θ is a function of the curvature radius R . For $R \rightarrow \infty$, $\kappa/R \sin \theta \rightarrow 0$ and Eq. (1) transforms into the → *Young's rule* [vi],

$$\gamma_{23} - \gamma_{12} + \gamma_{13} \cos \theta_0 = 0. \quad (2)$$

Thus, Eq. (1) can be rewritten in the form:

$$(\cos \theta_0 - \cos \theta) \sin \theta - \frac{\kappa}{\gamma_{13} R} = 0. \quad (3)$$

Note that γ_{23} , γ_{12} , γ_{13} , κ , and θ depend on the electrode potential E .

Refs.: [i] Vesselovski VS, Pertzov VN (1936) *Zh Fis Khim* 8:245; [ii] Gretz RD (1966) *J Chem Phys* 45:3160; [iii] Tarazona P, Navascués G (1981) *J Chem Phys* 75:3114; [iv] Mostany J, Mozota J, Scharifker BR (1984) *J Electroanal Chem* 177:25; [v] Toshev BV, Platikanov D, Scheludko A (1988) *Langmuir* 4:489; [vi] Young T (1805) *Philos Trans R Soc* 95:65; [vii] Gibbs JW (1928) *Collected works, vol. 1. New Haven*; [viii] Kolarov T, Scheludko A, Exerova D (1968) *Trans Faraday Soc* 64:2864; [ix] Navascués G, Tarazona P (1981) *J Chem Phys* 75:2441; [x] Exerova D, Kashchiev D, Platikanov D, Toshev BV (1994) *Adv Colloid Interface Sci* 49:303

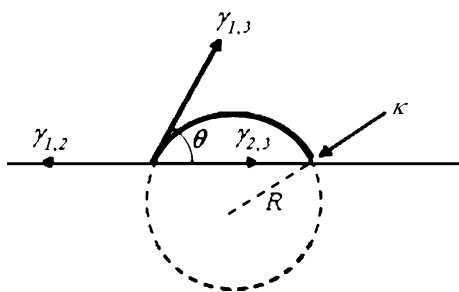

Equilibrium form of crystals and droplets — Liquid droplets — Figure. Cross section of a liquid droplet formed on a flat foreign substrate

Solid crystals — If a crystal contacts a foreign substrate (the working electrode) the total free surface energy Φ of the system crystal–solution–foreign substrate is given by [i]

$$\Phi = \sum_j \gamma_j S_j + \sum_k (\gamma_{i,k} - \gamma_s) S_{i,k}. \quad (4)$$

Here γ_j and S_j are the specific free surface energies (→ *surface energy*) and the surface areas of the crystal faces, which contact only the solution; $\gamma_{i,k}$ and $S_{i,k}$ are the specific free interfacial energies and the surface areas of the faces which contact the foreign substrate and γ_s is the substrate specific free surface energy (the quantities γ_s , γ , and γ_i correspond to γ_{12} , γ_{13} , and γ_{23} from → *Equilibrium form of crystals and droplets* → *liquid droplets*). Substituting the difference $\gamma_{i,k} - \gamma_s$ for $\gamma_k - \beta_k$ according to the rule of Dupré (→ *Dupré equation*) [ii] one obtains

$$\Phi = \sum_j \gamma_j S_j + \sum_k (\gamma_k - \beta_k) S_{i,k}, \quad (5)$$

where β_k is the specific free adhesion energy and γ_k is the specific free surface energy that the face k would have if the substrate was absent. Since a closed crystal polyhedron can be considered as composed of pyramids with a common apex P (point of Wulff) inside the crystal, its volume \tilde{V} is given by

$$\tilde{V} = (1/3) \sum_j h_j S_j + (1/3) \sum_k h_k^* S_{i,k}, \quad (6)$$

where h_j and h_k^* are the distances between the Wulff's point and the j and k faces (Fig. 1).

Making use of Eqs. (2) and (3) the condition for the equilibrium form $d\Phi = 0$, $dV = 0$ leads to Wulff's rule (Gibbs–Curie–Wulff theorem [iii–v]) generalized by → *Kaischew* [i] to account for the crystal–substrate interaction:

$$\text{AM} \quad \gamma_j / h_j = \lambda \quad (7)$$

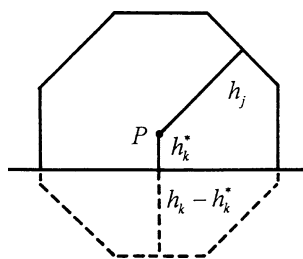

Equilibrium form of crystals and droplets — Solid crystals — Figure. Equilibrium form of a cubic crystal formed on a foreign substrate (cross section)

or

$$\gamma_1 : \gamma_2 : \dots : \gamma_j : \dots = h_1 : h_2 : \dots : h_j : \dots \quad (5.4')$$

for the crystal faces which contact only the parent phase, and

$$(\gamma_k - \beta_k)/h_k^* = \lambda \quad (8)$$

or

$$\begin{aligned} \gamma_1 - \beta_1 : \gamma_2 - \beta_2 : \dots : \gamma_k - \beta_k : \dots \\ = h_1^* : h_2^* : \dots : h_k^* : \dots \end{aligned} \quad (5.5')$$

for the crystal faces which contact the foreign substrate where λ is a material constant [iv]. The quantities γ and β depend on the electrode potential E .

Refs.: [i] Kaischew R (1951) *Commun Bulg Acad Sci* 2:191; [ii] Dupré A (1869) *Theorie mécanique de la chaleur*. Gauthier-Villard, Paris; [iii] Gibbs JW (1878) *Am J Sci Art* 16:454; [iv] Curie P (1885) *Bull Soc Mineralog* 8:145; [v] Wulff G (1901) *Z Kristallogr* 34:449; [vi] Milchev A (2002) *Electrocrystallization: fundamentals of nucleation and growth*. Kluwer, Boston

AM

Equivalent circuit → *circuit*

Equivalent conductivity → *conductivity*

Equivalence point (of a titration) — A theoretical point in the progress of a titrimetric reaction located where the reaction between the analyte and reagent is stoichiometrically complete [i].

Ref.: [i] Mendham J, Denney R, Barnes J, Thomas M (2000) *Vogel's quantitative chemical analysis*. Prentice Hall, New Jersey

FG

Erdey-Grúz, Tibor



(Oct. 27, 1902, Budapest, Hungary (Austro-Hungarian Empire) – Aug. 16, 1976, Budapest, Hungary) Erdey-Grúz earned his M.Sc. and Ph.D. degrees from the University of Budapest. After receiving his Ph.D. degree

in 1924, he joined the staff of the same university. He worked for the University of Budapest (presently Eötvös Loránd University, Budapest) until his death, from 1941 as a full professor. He became a member of the Hungarian Academy of Sciences in 1943 and was the president of the Academy between 1970 and 1976. He published valuable works on the transport processes in electrolyte solutions, → *electrocrystallization* [i, ii], adsorption, catalysis, and oxygen overvoltage, however, his most important result was achieved while working with → *Volmer* in Berlin. They published together a pivotal paper [iii] on the hydrogen overpotential in which the proper relationship between the current and the electrode potential was formulated for the first time (→ *Erdey-Grúz–Volmer equation*). This seminal paper can be considered as a landmark since the Nernstian equilibrium theory already hindered the development of electrochemistry. The importance of their contribution has been widely acknowledged. Bockris expressed this view in a most adequate manner [iv]: “Erdey-Grúz and Volmer, whom I see as the fathers of electrode kinetics...” Erdey-Grúz published several books on transport processes [v] and electrochemical kinetics [vi].

Refs.: [i] Erdey-Grúz T, Volmer M (1931) *Z phys Chem* A157:165; [ii] Erdey-Grúz T (1933) *Naturwiss* 21:799; [iii] Erdey-Grúz T, Volmer M (1930) *Z phys Chem* A150:203–213; [iv] Bockris JO'M (1991) *Electrochim Acta* 36:1–4; [v] Erdey-Grúz T (1974) *Transport phenomena in aqueous solutions*. Hilger, London; [vi] Erdey-Grúz T (1972) *Kinetics of electrode processes*. Akadémiai Kiadó, Budapest

GI

Erdey-Grúz–Volmer equation — see → *Butler–Volmer equation* → *Erdey-Grúz* and → *Volmer* developed the theory of electrode processes in 1930 [i]. They recognized that these processes should be studied by applying the laws of reaction → *kinetics*, and that electrolytic hydrogen → *overpotential* (on the electrodes characterized by large overpotential) is due to the slow neutralization of hydrogen ions which, in turn, is caused by the high → *activation energy* of this process. As shown by Erdey-Grúz and Volmer, the → *energy of activation* can be changed in a controllable manner by varying the potential. The → *transfer coefficient* (α) introduced by these authors permits the interpretation of the experimental results without a detailed knowledge of the transition state (activated complex) and the energetic structure of the electrochemical → *double layer*. Based on this kinetic model the relationship between the reversible (equilibrium) potential (→ *potential*, subentry → *equilibrium electrode potential*) and the concentration of the species participating in the electrode reaction, i.e., the → *Nernst*

equation, was also derived which had originally been established only by thermodynamic consideration, and the \rightarrow Tafel relationship was properly elucidated.

In Ref. [i] the following equations can be found:

$$\frac{J}{F} = k_2 c_+ e^{-\frac{\alpha E F}{RT}} - k_3 c_H e^{+\frac{\alpha E F}{RT}}, \quad (1)$$

where J is current, F is the \rightarrow Faraday constant, k_2 and k_3 the rate constants of the neutralization of the hydrogen atom and the ionization of the hydrogen, respectively, c_+ and c_H are the concentrations of the hydrogen ions and the hydrogen at the electrode surface, E is the electrode potential, α is the transfer coefficient, R is the \rightarrow gas constant, and T is the thermodynamic temperature.

At equilibrium, i.e., at the reversible potential (E_r)

$$\frac{J}{F} = k_2 c_+ e^{-\frac{\alpha E_r F}{RT}} - k_3 c_H e^{+\frac{\alpha E_r F}{RT}} = 0. \quad (2)$$

At overpotential η

$$J = F k_2 c_+ e^{-\frac{\alpha(E_r+\eta)F}{RT}} - F k_3 c_H e^{+\frac{\alpha(E_r+\eta)F}{RT}}. \quad (3)$$

A high negative η , $\eta > 0.03$ V

$$J = F k c_+ e^{-\frac{\alpha \eta F}{RT}}. \quad (4)$$

It soon became clear that the relationships derived from the above concept for the hydrogen overpotential constitute the general basis of the theory of the electrode processes, with \rightarrow charge transfer as the rate-determining step.

Ref.: [i] Erdey-Grúz T, Volmer M (1930) Z phys Chem A150:203

GI

Error (of measurement) — A numerical difference between a measured (or estimated) datum and the \rightarrow true value. Every measurement process is subject to \rightarrow random and/or \rightarrow systematic errors [i].

Random error — The difference between an observed value and the mean that would result from an infinite number of measurements of the same sample carried out under repeatability conditions. It is also named *indeterminate error* and reflects the \rightarrow precision of the measurement [i]. It causes data to be scattered according to a certain probability distribution that can be symmetric or skewed around the mean value or the median of a measurement. Some of the several probability distributions are the normal (or Gaussian) distribution, logarithmic normal distribution, Cauchy (or Lorentz) distribution, and Voigt distribution. Voigt distribution is

a \rightarrow convolution of a normal distribution and a Cauchy distribution [ii].

Systematic error — A kind of \rightarrow error that can be ascribed to a definite cause and even predicted if all the aspects of the measurement are known. It is also named *determinate error*. Systematic errors are usually related to the \rightarrow accuracy of a measurement since their deviations are generally of the same magnitude and unidirectional with respect to the \rightarrow true value. There are basically three sources of systematic errors: \rightarrow instrumental errors, \rightarrow methodic errors, and \rightarrow operative errors [iii]. In addition, systematic errors can be classified as \rightarrow constant errors and \rightarrow proportional errors [iv].

Constant error — A kind of systematic error of constant magnitude which is independent of the size of the \rightarrow sample.

Instrumental error — A sort of systematic error caused by failure of measuring devices to function in accordance to required standards.

Methodic error — A type of systematic error arising from nonideal chemical or physical behavior of analytical systems.

Operative error — A kind of systematic error resulting from the carelessness, inattention, or personal limitations of the experimenter.

Proportional error — A sort of error with a magnitude that is fixed by the size of the \rightarrow sample to be analyzed.

Refs.: [i] Harris D (2002) Quantitative chemical analysis. WH Freeman, New York; [ii] Hogg RV, Ledolter J (1991) Applied statistics for engineers and physical scientists. Prentice Hall, New Jersey; [iii] IUPAC (1997) Compendium of chemical terminology; [iv] Skoog D, West D, Holler F (1996) Fundamentals of analytical chemistry. Saunders College Publishing, New York

FG

ESCR model \rightarrow electrochemically stimulated conformational relaxation model

Esin–Markov coefficient — Various cross-differential relationships can be obtained from the \rightarrow Gibbs–Lippmann equation because it is a complete differential. For instance,

$$\left(\frac{\partial E}{\partial \mu_{KA}^\beta} \right)_{T,p,\sigma^\alpha, \mu_B} = - \left(\frac{\partial \Gamma_{K^+}^\beta}{\partial \sigma^\alpha} \right)_{T,p, \mu_{KA}, \mu_B} \quad (1)$$

where E is the \rightarrow electrode potential of the \rightarrow nonpolarizable electrode, μ_{KA} is the \rightarrow chemical potential of the salt KA in the electrolyte (phase β), $\Gamma_{K^+}^\beta$ is the surface excesses of the charged species K^+ at the electrolyte side of

the interfacial region, and σ^α is the free \rightarrow charge density on phase α (e.g., on liquid mercury), T is the temperature, p is the pressure. It is called the Esin and Markov coefficient.

Refs.: [i] Trasatti S, Parsons R (1986) *Pure Appl Chem* 58:437; [ii] Bard AJ, Faulkner LR (2001) *Electrochemical methods*, 2nd edn. Wiley, New York, pp 554–555

GI

ESPR \rightarrow plasmon resonance

Etching — A method of surface patterning in which an image is incised into the surface of a processed solid material using aggressive chemicals. This may be achieved by using solutions of acids or oxidants (wet etching), or by using aggressive gases (dry etching). Etching is widely used in the electronic industry in manufacturing of printed circuit boards where an excess of copper foil has to be removed from insulator plates. Usually this is achieved by oxidation with iron(III) chloride solutions. In semiconductor fabrication industries the patterning of silicon wafers is performed by removing the silicon with HF. Chemical etching combined with polishing (chemical-mechanical polishing) is widely used for removal of excess of material and flattening of a surface. Etching is also used for surface finishing to remove oxide layers or other unwanted deposits. Especially composite etching solutions are used in metallurgy for developing of grains. In galvano-technique processes chemical etching (usually in diluted acid or alkali solutions) is applied for the activation of the substrate metal before \rightarrow electroplating. See also \rightarrow electrochemical machining.

Refs.: [i] Varteresian J (2002) *Fabricating printed circuit boards*. Elsevier, New York; [ii] Maruyama K, Ohkawa H, Ogawa S, Ueda A, Niwa O, Suzuki K (2006) *Anal Chem* 78:1904

MD

Ethanol — Common \rightarrow solvent in chemistry and potential fuel in \rightarrow fuel cells. $T_{\text{mp}} = -114.5^\circ\text{C}$, $T_{\text{bp}} = 78.3^\circ\text{C}$, $\varepsilon_r = 24.5$, $\mu = 11.2 \times 10^{-30}$ Cm.

RH

Ethers — Class of organic compounds of the general formula $\text{R-O-R}'$ with R and R' being organic groups. Popular \rightarrow solvent.

RH

Euler-Deckart rule — The crystals are surrounded by faces, edges, and apexes, the number of which fulfils the relation of Euler-Deckart:

$$\text{Faces} + \text{Apexes} = \text{Edges} + 2.$$

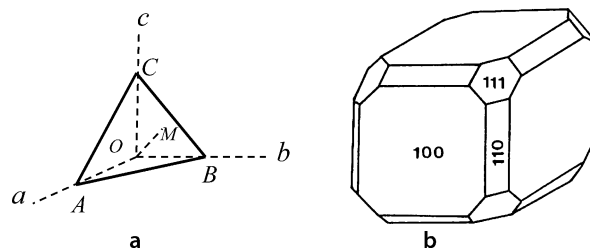

Euler-Deckart Rule — Figure. A crystal face ABC (a) and a crystal with a simple cubic lattice and (100), (111), and (110) faces (b)

The position of every crystal face ABC (Fig. 1) is defined by the intercepts OA, OB, and OC and the angles ψ_a , ψ_b , and ψ_c between the normal OM to the face ABC and the axes a, b, and c [i]. The definition ratio is:

$$\cos \psi_a : \cos \psi_b : \cos \psi_c = 1/OA : 1/OB : 1/OC.$$

Ref.: [i] Milchev A (2002) *Electrocrystallization: Fundamentals of nucleation and growth*. Kluwer, Boston

AM

EXAFS — Extended X-ray absorption fine structure spectroscopy. X-ray spectroscopy close and slightly above the X-ray absorption edge. See \rightarrow surface analytical methods.

RH

Exchange current density — When an electrode reaction is in equilibrium, the reaction rate in the anodic direction is equal to that in the cathodic direction. Even though the net current is zero at equilibrium, we still envisage that there is the anodic current component (I_a) balanced with the cathodic one (I_c). The current value $I_0 \equiv I_a = |I_c|$ is called the “exchange current”. The corresponding value of current density $j_0 \equiv I_0/A$ (A , the electrode area) is called the “exchange current density”. If the rate constants for an electrode reaction obey the \rightarrow Butler-Volmer equation, j_0 is given by

$$\begin{aligned} j_0 &= nFk_s c_O^* \exp \left[-\frac{\alpha nF}{RT} (E_e - E_c^{\ominus'}) \right] \\ &= nFk_s c_R^* \exp \left[\frac{(1-\alpha)nF}{RT} (E_e - E_c^{\ominus'}) \right], \end{aligned}$$

where k_s is the \rightarrow standard rate constant, α the \rightarrow transfer coefficient, E_e the \rightarrow equilibrium electrode potential, and $E_c^{\ominus'}$ the \rightarrow formal potential. Because c_O^* and c_R^* , i.e., the bulk concentrations of O and R are related at equilibrium by the \rightarrow Nernst equation, j_0 is then expressed as:

$$j_0 = nFk_s (c_O^*)^{1-\alpha} (c_R^*)^\alpha.$$

Since j_0 is thus proportional to k_s , it is regarded as one of the kinetic parameters for electrode reactions.

Ref.: [i] Bard AJ, Faulkner LR (2001) *Electrochemical methods*, 2nd edn. Wiley, New York

E

Excited state — is the state of a system with energy higher than that of the ground state. This term is most commonly used to characterize a molecule in one of its electronically excited states, but can also refer to vibrational and/or rotational excitation in the electronic ground state.

Ref.: [i] Muller P (1994) *Pure Appl Chem* 66:1077

Exciton — A bound and thus localized pair of an \rightarrow electron in the conduction band and a \rightarrow hole in the valence band. An exciton is an elementary excitation and quasiparticle in solids. See also \rightarrow Frenkel, \rightarrow defects in solids.

Ref.: [i] Elliott SR (1998) *The physics and chemistry of solids*. Wiley, Chichester

TO

WK

FS

Exclusion zone \rightarrow nucleation, subentry \rightarrow exclusion zone

Exocytosis — A process in which a substance is released from a eukaryotic cell without passing through the cell membrane. These substances may be waste products of the cell or newly-synthesized molecules that are incorporated in a plasma membrane. These \rightarrow vesicles are transported to the cell membrane, the vesicle membrane fuses with the cell membrane, and the content of the vesicle is released out of the cell. The opposite process is \rightarrow endocytosis. Endo- and exocytosis are fundamental processes of membrane fusion in living cells. See also \rightarrow membrane.

BM

Exponential decay — Many natural processes can be described by the differential equation $dx/dt = -\lambda x$. This means that the temporal decay of a physical quantity x is proportional to its absolute value. The solution of this differential equation is $x = x_0 e^{-\lambda t}$ for x_0 being the starting value of x . The constant λ is called the decay constant and its reciprocal value $\tau = \lambda^{-1}$ is called \rightarrow time constant because it has the unit of time, and it is the time necessary for a decay of x to $x_0 e^{-1} = 0.367 \dots \times x_0$. Typi-

cal examples for exponential decays in electrochemistry are (a) the capacitive current decay following a potential step, where in case of a simple circuit containing only a capacity C and an ohmic resistor R in parallel, the time constant is $\tau = 1/RC$, which follows from $I = U/R = -\frac{dQ}{dt} = -C \frac{dU}{dt} = -CR \frac{dI}{dt}$ (I - current, U - voltage, Q - charge) since the solution of the latter equation reads $I = I_0 e^{-t/RC}$. See also \rightarrow RC constant and \rightarrow electrochemical impedance spectroscopy. (b) In case of a circuit with an ohmic resistor R and an induction L the time constant follows as $\tau = R/L$. Other examples of exponential decays following an equation like $dx/dt = -\lambda x$, and characterized by a decay constant λ are the decay of intensity of radiation by absorption in an isotropic medium (Bouguer–Lambert–Beer law), the radioactive decay and the response of \rightarrow flow-through detectors that can be characterized by a \rightarrow response time.

Refs.: [i] Oldham KB, Myland JC (1994) *Fundamentals of electrochemical science*. Academic Press, San Diego, p 20, 400; [ii] Westphal WH (ed) (1952) *Physikalisches Wörterbuch*. Springer, Berlin; [iii] Macdonald JR (1987) *Impedance spectroscopy*. Wiley, New York

FS

Extended defects \rightarrow defects in solids

Extraction — is a dynamic process of transferring a chemical compound or species from one phase to another phase. It is a separation process and can be also a preconcentration. One distinguishes liquid–liquid, liquid–solid, and liquid–gas extraction. Not very frequently, liquid–liquid extraction has been used as a separation step, sometimes also as a preconcentration step before electroanalytical measurements. Sometimes the electroanalysis was performed in the organic extract, and the term extraction-voltammetry (or \sim polarography) was used. Because liquid–liquid extractions need organic solvents and produce contaminated samples, this kind of analysis has serious disadvantages compared to \rightarrow stripping voltammetry. A comparison of different separation techniques with voltammetric analysis is given in [i].

Ref.: [i] Möller A, Scholz F (1996) *Fresenius J Anal Chem* 356:160

MD

Extraction-polarography \rightarrow extraction

Extraction-voltammetry \rightarrow extraction

F

Facilitated transfer (at ITIES) — Facilitated transfer of an ion across the → interface between two immiscible electrolyte solutions (ITIES) is an important class of charge transfer reactions at ITIES involving not only the transferring ion, but also another ion or a neutral ligand which can be distributed on either side of the interface [i]. The coupling of the → ion transfer at liquid–liquid interfaces with the homogeneous ion association or complexation shifts the partition of the transferred ion in favor of one of the adjacent liquid phases. Figure 1 shows the scheme of various pathways for the transfer of an ion M^{z+} in the presence of a neutral ligand L. These pathways can be classified as the transfer by interfacial complexation (TIC), ion transfer followed by organic phase complexation (TOC), or aqueous complexation followed by transfer of the complex (ACT) [ii]. The classical description of the mechanism as a reaction with one electrochemical (E) and one chemical (C) step, i.e., E, EC, and CE reaction, respectively, assumed that the partition of the ligand L is shifted wholly in favor of the organic phase [iii]. These reactions have been studied mainly by → cyclic voltammetry [iv] (Fig. 2), AC voltammetry [iii], and by current scan → polarography [v]. Following the first attempt to explain the voltammetric behavior in terms of the standard ion transfer potential and the complex stability constant [i], a fundamental approach to the transport problem in polarography [vi] and cyclic voltammetry [vii, viii] has been developed. Although a large number of ion transfer processes of this type were studied, kinetic data are few pointing to

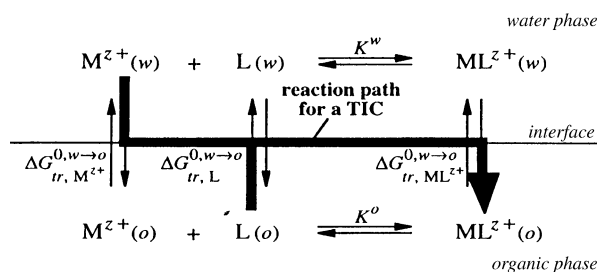

Facilitated transfer (at ITIES) — Figure 1. Various reaction pathways for the transfer of an ion M^{z+} in the presence of a neutral ligand L, with highlighted transfer by interfacial complexation (TIC). Reprinted with permission from [ii]. © 2000 Elsevier B.V.

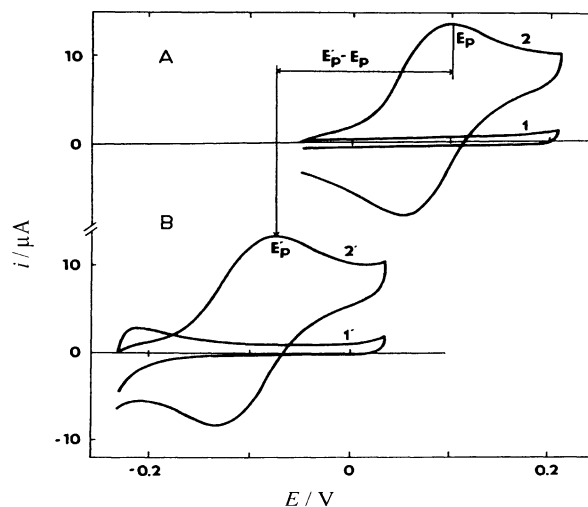

Facilitated transfer (at ITIES) — Figure 2. Cyclic voltammograms (0.02 V s^{-1}) of supporting electrolytes (1,1') and 1 mM 2-phenylethylammonium ion (2,2') in the absence (A) and presence (B) of 10 mM 2,3,11,12-dibenzo-1,4,7,10,13,16-hexaoxacyclooctadecane (dibenzo-18-crown-6) in the organic phase. Reprinted with permission from [iv]. © 1991 Elsevier B.V.

fast ion transfer kinetics with the apparent standard rate constant (→ reaction rate) exceeding 1 cm s^{-1} [ix, x].

Another type of the facilitated transfer is that involving molecules with acid–base properties. A construction of ion partition diagram of the solute, which is analogous to Pourbaix's → potential–pH diagrams widely used in electrochemistry of corrosion, has been proposed as a convenient tool that makes it possible to relate the voltammetric behavior to the partition of the neutral and the ionic species, as well as to acid–base equilibria in the adjacent liquid phases [xi].

Refs.: [i] Homolka D, Hung LQ, Hofmanová A, Khalil MW, Koryta J, Mareček V, Samec Z, Sen SK, Vanýsek P, Weber J, Březina M (1980) *Anal Chem* 52:1606; [ii] Reymond F, Fermín D, Lee HJ, Girault HH (2000) *Electrochim Acta* 45:2647; [iii] Kakutani T, Nishiwaki Y, Osakai T, Senda M (1986) *Bull Chem Soc Jpn* 59:781; [iv] Dvořák O, Mareček V, Samec Z (1991) *J Electroanal Chem* 300:407; [v] Yoshida Z, Freiser H (1984) *J Electroanal Chem* 162:307; [vi] Matsuda H, Yamada Y, Kanamori K, Kudo Y, Takeda Y (1991) *Bull Chem Soc Jpn* 64:1497; [vii] Kakiuchi T, Senda M (1991) *J Electroanal Chem* 300:431; [viii] Reymond F, Carrupt PA, Girault HH (1998) *J Electroanal Chem* 449:49; [ix] Beattie PD, Delay A, Girault HH (1995) *Electrochim Acta* 40:2961; [x] Cai CX, Tong Y, Mirkin MV (2004) *J Phys Chem Soc* 108:1787; [xi] Reymond F, Steyaert G, Carrupt PA, Testa B, Girault HH (1996) *J Am Chem Soc* 118:11951

Falkenhagen, Hans



F

(May 13, 1895, Wernigerode, Germany – June 26, 1971, Rostock, Germany) Studied physics, mathematics, and chemistry in Heidelberg, Munich, and Göttingen. Ph.D. 1921 Göttingen, 1924 habilitation Cologne. 1927/28 working with → Debye in Zurich and Leipzig. Following appointments in Cologne and Dresden, from 1949–1964 Professor of Theoretical Physics in Rostock. Together with Debye he could explain the dispersion of → conductivity [i–iii], he could give a qualitative theory of the → Wien effect [iv], and finally a theory of viscosity of → electrolytes [v]. The entire theory that evolved in the group of Debye is sometimes referred to as the Debye–Hückel–Onsager–Falkenhagen theory (→ Debye–Hückel–Onsager theory). Falkenhagen wrote well-known books and book chapters on the theory of electrolytes [iv].

Refs.: [i] Debye P, Falkenhagen H (1928) *Z Elektrochem* 24:562; [ii] Falkenhagen H, Debye P (1928) *Phys Z* 29:121; [iii] Falkenhagen H, Debye P (1928) *Phys Z* 29:401; [iv] Falkenhagen H, Kelbg G (1954) *Z Elektrochem* 58:653; [v] Falkenhagen H (1931) *Nature* 127:439; [vi] (a) Falkenhagen H (1932) *Elektrolyte*. S Hirzel, Leipzig; Engl transl: Falkenhagen H (1934) *Electrolytes*. Clarendon, Oxford; (b) Falkenhagen H (with contributions of Ebeling W and Hertz HG) (1971) *Theorie der Elektrolyte*. S Hirzel, Leipzig; (c) Falkenhagen H, Kelbg G (1959) *The present state of the theory of electrolytes*. In: Bockris JO'M, Conway BE (eds) *Modern aspects of electrochemistry*. Butterworth, London

FS

Farad — SI-derived measurement unit for → capacitance. Symbol: F (named in honor of the British physicist and chemist → Faraday).

Definition: A condenser has the capacitance of 1 farad, when a charge of 1 → coulomb generates a voltage of 1 → volt.

$$1 \text{ F} = 1 \text{ C V}^{-1} = 1 \text{ C}^2 \text{ J}^{-1} = \text{m}^{-2} \text{ kg}^{-1} \text{ s}^4 \text{ A}^2 .$$

Ref.: [i] Cohen ER, Cvitas T, Frey JG (eds) (2006) *IUPAC quantities, units and symbols in physical chemistry*

BM

Faradaic current → current

Faradaic efficiency (or coulometric efficiency) — Relates the moles of product formed in an → electrode reaction to the consumed → charge. The faradaic efficiency is 1.00 (or 100%) when the moles of product correspond to the consumed charge as required by → Faraday's law. See also → current efficiency, → coulometry.

FS

Faradaic efficiency measurement → Tubandt method

Faradaic reaction — An electron transfer reaction obeying → Faraday's laws and proceeding at an → electrode (charged interface).

FS

Faradaic rectification — When the electrode potential of the working → electrode is modulated with a sinusoidal → alternating current the mean potential is shifted from the DC value by a small increment in many cases when the AC modulation is sufficiently large. This effect has been named faradaic rectification, it is caused by the nonlinearity of the electrode response, in particular the variation of current with electrode potential [i]. A theoretical treatment for an electrode in contact with a solution containing a redox system has been provided [ii]. It was extended to reactions where one reactant is present in its element form dissolved in the liquid metallic phase (e.g., $\text{Cd}^{2+} + 2\text{e}^- \rightarrow \text{Cd}_{(\text{Hg})}$) [iii]. An improved evaluation technique has been proposed [iv], and some inherent problems have been reviewed [v]. A variant of this method applied to → polarography has been described [vi]. Second and higher harmonics in → AC voltammetry (polarography) [vii] also arise from this nonlinearity, and hence these techniques also have some characteristics that resemble those found in → faradaic rectification voltammetry.

See also → impedance, → electrochemical impedance spectroscopy.

Refs.: [i] Doss KS, Agarwal HP (1951) *Proc Ind Acad Sci* 34A:229; Hillson PJ (1954) *Trans Faraday Soc* 50:385; Oldham KB (1957) *Trans Faraday Soc* 53:80; Agarwal HP (1971) *Electrochim Acta* 16:1395; [ii] Doss KS, Agarwal HP (1951) *Proc Ind Acad Sci* 34A:263; Doss KSG, Agarwal HP (1951) *Proc Ind Acad Sci* 33A:66; Doss KS, Agarwal HP (1952) *Proc Indian Acad Sci* 35:45; [iii] Barker GC, Faircloth RL, Gardner AW (1958) *Nature* 181:247; [iv] Bauer HH, Smith DL, Elving PJ (1960) *J Am*

Chem Soc 82:2094; [v] de Leuwe R, Sluyters-Rehbach M, Sluyters JH (1967) *Electrochim Acta* 12:1593; [vi] van der Pol F, Sluyters-Rehbach M, Sluyters JH (1973) *J Electroanal Chem* 45:377; [vii] Bauer HH, Foo DCS (1966) *Australian J Chem* 19:1103

Faradaic rectification voltammetry — A → *voltammetry* technique utilizing an asymmetric current response to a symmetric voltage perturbation (usually sinusoidal and large enough to induce nonlinear effects) or *visa versa* [i–iv]. See also → *faradaic rectification*.

Refs.: [i] Delahay P (1961) *Fast electrode processes by relaxation methods*. In: Delahay P (ed) *Advances in electrochemistry and electrochemical engineering*, vol. 1. Interscience, New York, Chap. 5; [ii] Reinmuth WH (1964) *Anal Chem* 36:211R; [iii] Bond AM (1980) *Modern polarographic methods in analytical chemistry*. Marcel Dekker, New York, pp 296, 298, 361; [iv] Agarwal HP (1974) *Faradaic rectification method and its applications in the study of electrode processes*. In: Bard A (ed) *Electroanalytical chemistry*, vol. 7. Marcel Dekker, New York, pp 161

RH

use today to discuss electricity: ion, electrode, cathode, and anode. Two electrical units (for capacitance and charge) were named after Faraday to honor his accomplishments: → *farad* (F) is the SI unit of electric capacitance; → *Faraday constant* is a unit of electric charge.

Refs.: [i] Williams LP (1965) *Michael Faraday, A biography*. Basic Books, New York; [ii] Hamilton J (2004) *A life of discovery: Michael Faraday, giant of the scientific revolution*. Random House; [iii] Ihde AJ (1961) In: Farber E (ed) *Great chemists*. Interscience Publishers, New York, pp 465–480; [iv] Williams LP (1965) *Michael Faraday*. Basic Books, New York; [v] Williams LP (1967) *Brit J Phil Sci* 18:230; [vi] Jeffreys AE (1960) *Michael Faraday: A list of his lectures and published writings*. London

EK

Faraday box (cage, shield) — A grounded metallic box that houses and therefore protects the electrolytic cell (→ *galvanic cell*) and the unshielded parts of the cables from outside electrical radiation. This box minimizes the electric → *noise* in the measured signal and is especially useful in the cases of very low concentrations of → *electrode-reaction* substrates and of high resistance of the solution. The most popular design of it is based on a carton box covered with aluminum foil. Can be also built of wire mesh or as a series of parallel wires.

Refs.: [i] Stojek Z (2002) *Experimental setup*. In: Scholz F (ed) *Electroanalytical methods*. Springer, Berlin; [ii] http://en.wikipedia.org/wiki/Faraday_cage

ZS

Faraday constant — Symbol: F , SI unit: $C\ mol^{-1}$. Definition: $F = eN_A$, i.e., the → *elementary charge* (e) is multiplied by the Avogadro constant (N_A). Its best value (IUPAC 2005): $9.64853383(83) \times 10^4\ C\ mol^{-1}$.

Refs.: [i] Mills I, Cvitas T, Homann K, Kallay N, Kuchitsu K (eds) (1993) *IUPAC quantities, units and symbols in physical chemistry*. Blackwell, Oxford, p 58; [ii] <http://physics.nist.gov/cuu/constants>

GI

Faraday's law — The number of moles of a substance, m , produced or consumed during an electrode process, is proportional to the electric charge passed through the electrode, q . Assuming that there are no parallel processes, $q = nFm$, where n and F are the number of electrons appearing in the electrode reaction equation, and the → *Faraday constant*, respectively.

See also → *coulometry*, → *coulometric titration*.

TP

Faraday impedance → *impedance*

Fast scan rate cyclic voltammetry → *Cyclic voltammetry* executed using scan rates exceeding $10^5\ V\ s^{-1}$. Presently,

Faraday, Michael



(Courtesy of Faraday School, Winnipeg)

(Sep. 22, 1791, Newington, Surrey, UK – Aug. 25, 1867, Hampton Court, UK). Faraday made fundamental discoveries in the theory of electricity and electromagnetism [i–vi]. He provided the experimental background, which was later used by James Clerk Maxwell to develop classical electromagnetic field theory. Faraday was the first to produce an electric current from a magnetic field, invented the first electric motor and dynamo, demonstrated the relation between electricity and chemical bonding, discovered the effect of magnetism on light, and discovered and named diamagnetism. Faraday formulated two laws of electrochemistry: (1) The amount of a substance deposited on each electrode of an electrolytic cell is directly proportional to the quantity of electricity passed through the cell. (2) The quantities of different elements deposited by a given amount of electricity are in the ratio of their chemical equivalent weights. He introduced several words that we still

the record is $\sim 2 \times 10^6 \text{ V s}^{-1}$. Use of an \rightarrow *ultramicro-electrode* is essential to minimize the $R_{\text{u}}C$ time constant (the \rightarrow *uncompensated resistance*, R_{u} , increases as the electrode radius decreases but the \rightarrow *capacitance*, C , decreases as the square of the radius. Objective is usually to measure large heterogeneous or homogeneous rate constants [i, ii]. In practice, especially at solid electrodes, the maximum useful sweep rate is limited by surface redox reactions.

Ref.: [i] Amatore C, Maisonhaute (2005) *Anal Chem* 77:303; [ii] Bard AJ, Faulkner LR (2001) *Electrochemical methods*, 2nd edn. Wiley, New York, p 216

AMB

Faure accumulator \rightarrow *accumulator*

Faure electrode \rightarrow *accumulator*

Fechner, Gustav Theodor



(Reproduced from [i])

(Apr. 19, 1801, Groß Särchen, near Hoyerswerda, Germany – Nov. 18, 1887, Leipzig, Germany) [i, ii]. Physicist, psychologist, and philosopher. 1834–39 professor of physics in Leipzig, after 1843 professor of “Naturphilosophie” (natural philosophy) and anthropology. Fechner expanded the Weber law of physiology to the strong stimuli. Thus the Weber–Fechner law states that for weak and strong stimuli the sensation is proportional to the logarithm of the stimulus. Fechner extensively performed electrochemical experiments, esp. testing \rightarrow *Ohm’s law* for \rightarrow *galvanic cells*. He was the first to show that Ohm’s law can be applied to electrolyte solutions, and he was the first who claimed a “Übergangswiderstand” (\rightarrow *charge-transfer resistance*) at metal|electrolyte \rightarrow *interfaces* (it is not clear whether he has really observed charge-transfer resistances, or whether it was additional Ohmic resistances of surface layers) [ii]. Fechner was very influential by translating and completely rewriting volume 3 (“Lehrbuch des Galvanismus und der Elektrochemie”) of Jean Baptiste Biot’s textbook on experimental physics in which he gives a full account of

the state of knowledge in electrochemistry of his time, including his own findings [iii]. Fechner was the first who reported the observation of \rightarrow *electrochemical oscillations* in 1828 [iv]. See also \rightarrow *Fechner electroscope*.

Refs.: [i] Lasswitz K (1910) *Gustav Theodor Fechner*. F Frommanns Verlag (E Hauff), Stuttgart; [ii] Ostwald W (1896) *Elektrochemie. Ihre Geschichte und Lehre*. Veit, Leipzig; (English translation: Ostwald W (1980) *Electrochemistry. History and theory*. Amerind Publ Co, New Delhi); [iii] Fechner GT (1828–29) *Lehrbuch der Experimental-Physik oder Erfahrungs-Naturlehre von Jean Baptiste Biot*. Verlag von Leopold Voß; [iv] Fechner GT (1828) *Schweigg J Chemie Physik* 53:129

FS

Fechner electroscope (electrometer) \rightarrow *Electroscope* developed by \rightarrow *Fechner*. A \rightarrow *dry cell* consisting of 800 to 1000 pairs of metal foils was used to charge two metal condenser plates between which a thin strip of gold foil is hanging. As long as the gold foil is not charged it will hang completely vertical; however, minute charges will lead to a deviation from that position.

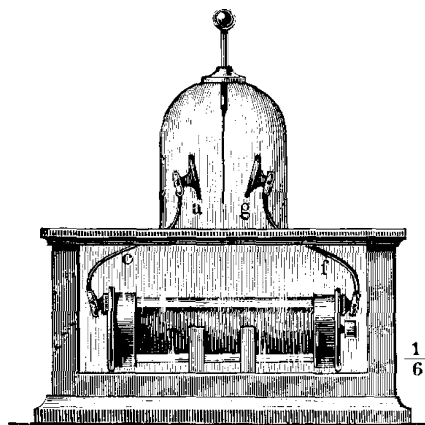

Fechner electroscope (electrometer) — Figure

Ref.: [i] Pfandlner L (1888–1890) *Müller-Pouillet’s Lehrbuch der Physik und Meteorologie*. 9th edn. vol. 3. Vieweg, Braunschweig, pp 364–365

FS

Fenton reagent generated in situ — Indirect electrochemical oxidation of aromatic compounds (e.g., benzene to phenol) proceeds with the Fenton reagent generated in situ electrochemically at the cathode by the reduction of ferric to ferrous salt and by the reduction of oxygen to hydrogen peroxide

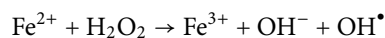
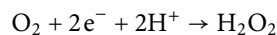
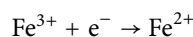

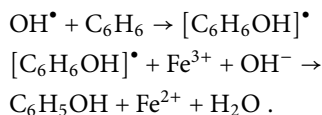

Addition of Cu^{2+} salt facilitates the following oxidation of benzene since Cu^{2+} ions are better oxidants than the Fe^{3+} ions

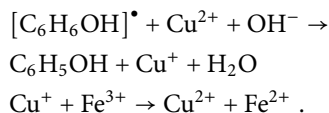

In summary, this oxidation of an aromate occurs in the course of oxygen reduction

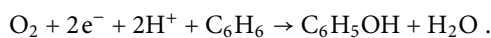

Refs.: [i] Amatore C, Pinson J, Savéant JM (1981) *J Am Chem Soc* 103:6930; [ii] Steckhan E, Wellman J (1977) *Chem Ber* 110:356; [iii] Tzedakis T, Savall A, Clifton MJ (1989) *J Appl Electrochem* 19:911; [vi] da Pozza A, Ferrantelli P, Merli C, Petrucci E (2005) *J Appl Electrochem* 35:391

Fermi, Enrico



(© The Nobel Foundation)

(Sep. 29, 1901, Rome, Italy – Nov. 28, 1954, Chicago, USA) Fermi studied at the University of Pisa, receiving his Ph.D. in 1922. Later he worked with → *Max Born* in Göttingen, Germany (1923) and Paul Ehrenfest in Leyden, Holland. In 1924 he returned to Italy occupying the position of lecturer in mathematical physics and mechanics at the University of Florence. He became professor of theoretical physics at the University of Rome in 1927 and professor of physics at Columbia University, USA (1939–1942). During the Second World War he participated in the Manhattan project. In 1939, Fermi and Leo Szilard (1898–1964) invented the nuclear reactor at Columbia University. They assembled the first full-scale ‘pile’, as Fermi dubbed it, and executed the first

controlled nuclear chain reaction on December 2, 1942. In 1926, Fermi discovered the statistical laws valid for particles obeying Pauli’s exclusion principle [i]. These particles are now referred to as fermions and the corresponding statistics as Fermi statistics (see → *Fermi–Dirac statistics* and also → *Fermi energy*, → *Fermi level*). In 1934 he developed the β -decay theory and demonstrated that nuclear transformation occurs in almost every element subjected to neutron bombardment. He was awarded the Nobel Prize in Physics in 1938.

Refs.: [i] Fermi E (1926) *Z Phys* 36:902; [ii] Fermi L (1954) *Atoms in the family: My life with Enrico Fermi*. University of Chicago Press, Chicago; [iii] Segrè E (1970) *Enrico Fermi: Physicist*. University of Chicago Press, Chicago

IH

Fermi–Dirac statistics — Fermi–Dirac statistics are a consequence of the extension of the application of Pauli’s exclusion principle, which states that no two electrons in an atom can be in the same quantum state, to an ensemble of electrons, i.e., that no two could have the same set of quantum numbers. Mathematically, in a set of indistinguishable particles, which occupy quantum states following the Pauli exclusion principle, the probability of occupancy for a state of energy E at thermal equilibrium is given by $f(E) = \frac{1}{e^{\frac{E-\mu}{k_B T}} + 1}$, where E is the energy, μ is the → *chemical potential*, k_B is the → *Boltzmann constant*, and T is the temperature.

Fermi–Dirac statistics apply to fermionic systems. Fermions are particles with half integral spin and that obey the Pauli exclusion principle.

Refs.: [i] Fermi E (1926) *Z Phys* 36:902; [ii] Dirac PAM (1926) *Proc R Soc London A* 112:661; [iii] French AP, Taylor EF (1978) *An Introduction to quantum physics*. Norton, New York; [iv] Blakemore JS (1987) *Semiconductor statistics*. Dover, New York

IH

Fermi energy — The Fermi energy of a system is the energy at which the Fermi–Dirac distribution function equals one half. In metals the Fermi energy is the boundary between occupied and empty electronic states at absolute temperature $T = 0$. In the → *Fermi–Dirac statistics* the so-called Fermi function, which describes the occupation fraction as a function of energy, is given by $f(E) = \frac{1}{e^{\frac{E-\mu}{k_B T}} + 1}$, where E is the energy, μ is the → *chemical potential*, and k_B is the → *Boltzmann constant*. The Fermi energy is given by $\lim_{T \rightarrow 0} \mu = E_F$, so that $f(E) = 1$ for $E < \mu$; and $f(E) = 0$ for $E > \mu$.

In metals the variation of the chemical potential for electrons with the temperature is quite small so that it

practically remains equal to the Fermi energy up to room temperature. For this reason at equilibrium between two phases such as metal and electrolyte or semiconductor and electrolyte, E_F is equal to the \rightarrow electrochemical potential of \rightarrow electrons in the electrolyte solution [iv–v].

Refs.: [i] Ashcroft W, Mermin ND (1976) *Solid state physics*. Saunders College, Philadelphia; [ii] Kittel C, Krömer H (2001) *Thermodynamik*. Oldenbourg, Munich; [iii] Mandel F (1988) *Statistical physics*. Wiley, Chichester; [iv] Bard AJ, Memming R, Miller B (1991) *Pure Appl Chem* 63:569; [v] Trasatti S, Parsons R (1986) *Pure Appl Chem* 58:437

IH

Fermi level — In metals or in systems with a continuous distribution of states the Fermi level is the energy level of a system described by \rightarrow Fermi–Dirac statistics between the effectively filled energy levels and effectively empty energy levels at which half the states are occupied.

In metals the chemical potential remains equal to the Fermi energy to a high degree of accuracy up to room temperature and the term Fermi level usually denotes \rightarrow chemical potential in solid-state physics. In semiconductors at temperatures $T \neq 0$ the chemical potential may significantly differ from the \rightarrow Fermi energy and in several cases there are no available states at this energy, but even in this case it is also a widespread practice to refer to the chemical potential of a semiconductor as the Fermi level.

Refs.: [i] Ashcroft W, Mermin ND (1976) *Solid state physics*. Saunders College, Philadelphia; [ii] Guggenheim EA (1959) *Thermodynamics, classical and statistical*. In: Flüge S (ed) *Encyclopedia of physics, principles of thermodynamics and statistics*, vol. III/2. Springer, Göttingen, pp 1–113

IH

Ferrocene (and derivatives) — Ferrocene and ferrocene derivatives are frequently employed redox systems in many electrochemical systems. Ferrocene is an organometallic “sandwich” compound consisting of an Fe(II) center and two symmetrically bound cyclopentadienide ligands. Ferrocene is readily oxidized to a ferrocenium cation (Fe(III)) which is stable in many organic solvents (the cation is unstable in the presence of strong nucleophiles). Substituted ferrocene derivatives such as \rightarrow decamethylferrocene are chemically much more inert and often employed as redox mediator systems (e.g., in glucose sensors [i]). By substituting the hydrogen atoms for electron-donating or electron-accepting groups, the reversible potential can be tuned to more negative or more positive potentials, respectively. Ferrocene has been recommended as internal potential reference system in organic solvents [ii] but the variation of the

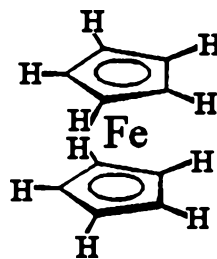

Ferrocene (and derivatives) — Figure

$\text{Fc}^{+/0}$ \rightarrow standard potential with solvent is not insignificant [iii].

Refs.: [i] Cass AEG, Davis G, Francis GD, Hill HAO, Aston WJ, Higgins IL, Plotkin EV, Scott LDL, Turner APF (1984) *Anal Chem* 56:667; [ii] Gritzner G, Kuta J (1984) *Pure Appl Chem* 56:461; [iii] Zanello P (2003) *Inorganic electrochemistry*. Royal Society of Chemistry, London

FM

Fiber electrodes \rightarrow microelectrodes in a form of bare fibers as the conductive elements, protruding from the end of an insulator, usually made of carbon fibers of 7–8 μm diameter and sealed in glass capillaries; often used for direct measurements (e.g., using fast \rightarrow cyclic voltammetry) of the in-vivo release of oxidizable neurotransmitters, such as dopamine, serotonin, norepinephrine, or epinephrine, from living cells. Also used to monitor electric activity of single nerve cells or for diagnostic purposes in electroanalysis. See also \rightarrow carbon fiber electrode.

PK, AL

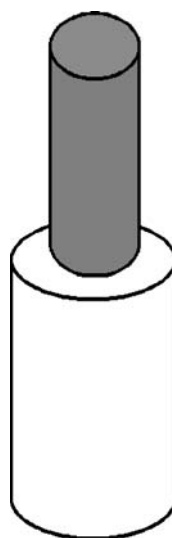

Fiber electrodes — Figure

Fichter, Friedrich



(July 6, 1869, Basel, Switzerland – June 6, 1952, Basel, Switzerland). Studied chemistry in Basel, Ph.D. at the University of Straßburg (at that time Germany, now Strasbourg, France); in 1903 extraordinary professor of inorganic chemistry at the University of Basel, from 1911–1939 full professor at that place. From 1907/08, Fichter performed electrochemical experiments with organic compounds, and in 1925 he could electrochemically transform isoeugenol to vanillin. Fichter wrote one of the first monographs entirely devoted to organic electrochemistry [i].

Ref.: [i] Fichter F (1942) *Organische Elektrochemie*. In: Bonhoeffer KF (ed) *Die Chemische Reaktion*, vol. 6. Verlag von Theodor Steinkopff, Dresden

Fick, Adolf Eugen



(Sep. 3, 1829, Kassel, Germany – Aug. 21, 1901, Blankenberghe, Belgium) Although Fick had an intense interest in mathematics as a schoolboy, he opted to study medicine on the advice of his brother. However, Fick supplemented these studies by attending additional lectures on 'analytical mechanics', i.e., mathematics. Having studied in Marburg and Berlin, he received his M.D.

in 1851 in Marburg. In 1852 he became Privatdozent at the Anatomical Institute of the University of Zurich (Switzerland). In 1868 he became full professor of physiology at the University of Würzburg (Germany). Realizing the great importance of diffusion across membranes, he derived [i] the basic laws which are now known as → *Fick's laws*. Thus, as a physiologist, he not only made fundamental contributions to physics (with implications for all branches of natural science) but he also introduced the study of diffusion into electrochemistry. Today, in medicine, he is rightly regarded as one of the founders of exact and experimental physiology [ii, iii].

Refs.: [i] Fick A (1855) *Ann Phys* 170:59; [ii] Wöhlisch E (1938) *Naturwiss* 26:585; [iii] Vandam LD, Fox JA (1988) *Anesthesiology* 88:514

FS

Fick's laws — The laws of diffusion were first formulated by → *Fick* [i]. The flux in the case of planar (one-dimensional or linear) diffusion can be described by Fick's first law:

$$-J_i(x, t) = D_i [\partial c_i(x, t) / \partial x], \quad (1)$$

where J_i ($\text{mol cm}^2 \text{s}^{-1}$) is the flux of species i , D_i ($\text{cm}^2 \text{s}^{-1}$) and c_i are the diffusion coefficient and the concentration (mol cm^{-3}) of species i , respectively, x is the location, ∂x is the distance (cm), and t (s) is the time.

The minus sign expresses that the diffusion proceeds from places where the concentration of i is higher towards those of lower concentration.

In electrochemical kinetics under steady-state electrolysis conditions often a simplified form of Eq. (1) is used:

$$J_i = D_i \frac{c_i^* - c_i(x=0)}{\delta_i}, \quad (2)$$

where c_i^* and $c_i(x=0)$ are the concentrations of species i in the bulk solution ($x \rightarrow \infty$) and at the electrode surface ($x=0$), respectively, and δ_i is the → *diffusion-layer thickness* (→ *diffusion layer*, → *Nernst-layer*).

If the concentration of species i at a given location x changes with time, Fick's second law should be considered:

$$[\partial c_i(x, t) / \partial x]_x = D_i [\partial^2 c_i(x, t) / \partial x^2]_t. \quad (3)$$

In order to obtain the concentration c_i at a location x and time t , the partial differential equation should be solved. It is possible if the initial (values $t=0$) and boundary conditions (values at certain location x) are known, i.e., if a model of diffusion is assumed [ii–v].

Equation (3) has been solved for many cases, e.g., \rightarrow *semi-infinite diffusion* (subentry of \rightarrow *diffusion*), and also in combination with the kinetic equation (potential-dependent rate) of \rightarrow *electrode reaction* for most of the transient experimental techniques [ii–iv].

Refs.: [i] Fick A (1855) *Ann Phys* 170:59; [ii] Erdey-Grúz T (1974) *Transport phenomena in aqueous solutions*. Hilger, London, pp 142–209; [iii] Bard AJ, Faulkner LR (2001) *Electrochemical methods*, 2nd edn. Wiley, New York, pp 148–151, 769; [iv] Atkins PW (1995) *Physical chemistry*. Oxford University Press, Oxford, pp 822–856; [v] Inzelt G (2002) *Kinetics of electrochemical reactions*. In: Scholz F (ed) *Electroanalytical methods*. Springer, Berlin, pp 245–278

GI

Film growth — refers to the process of systematic increase of the film thickness during its generation (deposition, see \rightarrow *electrodeposition*). It is observed during deposition of metals, polymer-like inorganic compounds (e.g., metal hexacyanoferrates or transition metal oxides) and organic \rightarrow *conducting polymers* (e.g., \rightarrow *polyaniline* or \rightarrow *polypyrrole*). The common mechanism of the film growth is based on the progressive \rightarrow *nucleation* with the three-dimensional diffusionally-controlled growth of the nuclei. In the case of multilayer organic–inorganic materials, the so-called layer-by-layer approach is particularly useful because it permits fabrication of three-dimensionally organized structures on \rightarrow *electrode surfaces*. In such multicomponent films, the distances between layers or orientation of molecules, can be controlled. The deposited layers can interact with each other through chemical, electrostatic and van der Waals (see \rightarrow *van der Waals forces*) intermolecular attraction forces. Representative examples include multilayers of \rightarrow *polyoxometallates*, large organic cations, ultrathin films of \rightarrow *conducting polymers*, \rightarrow *polyelectrolytes* and colloidal polyanions, as well as network films of surface-functionalized metal \rightarrow *nanoparticles*.

Refs.: [i] Mallouk TE, Kim HN, Ollivier PJ, Keller SW (1996) *Ultrathin films based on layered inorganic solids*, vol. 7. Pergamon Press, Oxford; [ii] Decher G, Lvov Y, Schmitt J (1994) *Thin Solid Films* 244:772; [iii] Harrison JA, Thirsk HR (1971) *The fundamentals of metal deposition*. In: Bard AJ (ed) *Electroanalytical chemistry*, vol. 5. Marcel Dekker, New York; [iv] Ingersoll D, Kulesza PJ, Faulkner LR (1994) *J Electrochem Soc* 141:140; [v] Ulman A (1991) *An introduction to ultrathin organic films from Langmuir–Blodgett to self-assembly*. Academic Press, New York; [vi] Zamborini FP, Leopold MC, Hicks JF, Kulesza PJ, Malik MA, Murray RW (2002) *J Am Chem Soc* 124:8958; [vii] Kulesza PJ, Chojak M, Karnicka K, Miecznikowski K, Palys B, Lewera A, Wieckowski A (1994) *Chem Mater* 16:4128; [viii] Cordova R, del Valle MA, Arratia A, Gomez H, Schrebler R (1994) *J Electroanal Chem* 377:75

PK, AL

Fill factor — The current versus potential $I(U)$ characteristics of a \rightarrow *power source*, contrarily to those of power dissipation devices, is not limited to the first and third quadrant. In this case the $I(U)$ curve crosses the U and I axes at values different from zero. The value of I at $U = 0$ is denoted \rightarrow *short-circuit current*, I_{sc} , and the value of U at $I = 0$ is denoted open-circuit potential, U_{oc} . The maximum power output, P_{max} , from a power source depends on the shape of the $I(U)$ curve and is given by $P_{max} = (UI)_{max}$, excluding first and third quadrant points. The fill factor FF is given by $FF = \frac{P_{max}}{I_{sc}U_{oc}}$.

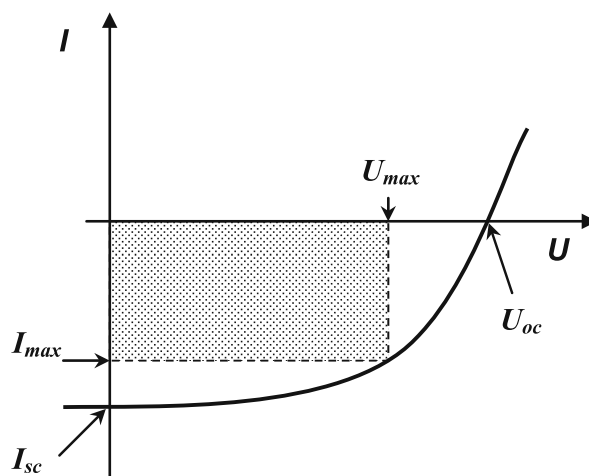

Fill factor — Figure

Refs.: [i] Seeger K (1991) *Semiconductor physics – An introduction*. Springer, Berlin; [ii] Ng KK (2002) *Complete guide to semiconductor devices*. Wiley, New York

IH

Filters — Current/potential filters are used in electroanalysis for reducing unwanted noise appearing during signal registration. Those are passive, electronic devices, which extract only part of the frequencies from the whole spectrum of recorded current frequencies. A low-pass filter is a filter that passes low frequencies well, but eliminates (or reduces) frequencies higher than the cut-off frequency. A high-pass filter passes the high frequencies but blocks the low ones, the opposite response of a low-pass filter.

A band-pass filter is a combination of two different filter circuits which will only allow passage of those frequencies that are neither too high nor too low. Filter circuits can be designed to accomplish this task by combining the properties of low-pass and high-pass into a single filter. The filters are used in \rightarrow *potentiostats* for improving recorded experimental signals, however improper

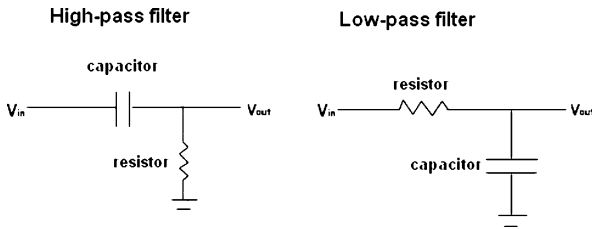

Filters — Figure 1

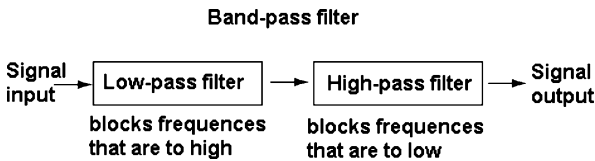

Filters — Figure 2

usage of filters can strongly deform the experimental results.

Active filters utilize an operational amplifier as part of the circuit and allow the design of any RLC filter without the need of an inductance. Filters of this type include Butterworth and Chebyshev filters.

Ref.: [i] Sedra AS, Smith KC (2004) *Microelectronic circuits*, 5th edn. Oxford University Press, Oxford; [ii] Horowitz P, Hill W (1990) *The art of electronics*, 2nd edn. Cambridge University Press, Cambridge, Chap. 5

MD

Finite difference — Finite difference is an iterative numerical procedure that has been used to quantify current-voltage-time relationships for numerous electrochemical systems whose analyses have resisted analytic solution [i]. There are two generic classes of finite difference analysis: 1. “explicit finite difference” (EFD), where a new set of parameters at $t + \Delta t$ is computed based on the known values of the relevant parameters at t and 2. “implicit finite difference” (IFD), where a new set of parameters at $t + \Delta t$ is computed based on the known values of the relevant parameters at t and on the yet-to-be-determined values at $t + \Delta t$. EFD is simple to encode and adequate for the solution of many problems of interest. IFD is somewhat more complicated to encode but the resulting codes are dramatically more efficient and more accurate – IFD is particularly applicable to the solution of “stiff” problems which involve a wide dynamic range of space scales and/or time scales.

Ref.: [i] Britz B (1988) *Digital simulation in electrochemistry*. Springer, Berlin

SWF

F

Finite element methods — The finite element method is a powerful and flexible numerical technique for the approximate solution of (both ordinary and partial) differential equations involving replacing the continuous problem with unknown solution by a system of algebraic equations. The method was first introduced by Richard Courant in 1943 [i], and over the next three decades, and particularly in the 1960s, a comprehensive mathematical framework was developed to underpin the method.

Implementation of the finite element method involves the partitioning of the solution domain into a set of non-overlapping, geometrically simple, “elements” (typically line segments in one spatial dimension, triangles or quadrilaterals in two spatial dimensions, for example) which together tessellate the whole domain. The differential equations are then reformulated into integral representations over the whole solution domain (the “weak formulation” of the problem – see below). The continuous unknown solution to the differential equation is then approximated in terms of “basis” functions which have a simple (polynomial) form over each of the elements. The whole problem reduces to the solution of a system of (possibly nonlinear) algebraic equations for the parameters defining the polynomials over each element which can then be solved to give the approximate solution which is a patchwork of the simple solutions over each of the elements.

To express this in more formal mathematical terms, we cast a partial differential equation in variational form (or integral form or weak formulation) by multiplying by a suitable function, integrating over the domain where the equation is posed and applying Green’s theorem. Thus, if we consider the reaction-diffusion equation

$$-\nabla^2 u + cu = f \quad \text{in } \Omega$$

with \rightarrow Dirichlet boundary conditions on the boundary of Ω which we denote $\partial\Omega$, we may multiply through by the function v and integrate to get

$$\int_{\Omega} (-\nabla^2 u + cu) v \, d\Omega = \int_{\Omega} f v \, d\Omega .$$

Applying Green’s theorem gives

$$\begin{aligned} \int_{\Omega} (\nabla u \cdot \nabla v + cuv) \, d\Omega - \int_{\partial\Omega} v (\nabla u) \cdot \mathbf{n} \, ds \\ = \int_{\Omega} f v \, d\Omega . \end{aligned}$$

If we choose v to be zero on $\partial\Omega$ the variational formulation of the problem requires us to find u satisfying certain regularity conditions and the Dirichlet boundary

conditions such that

$$\int_{\Omega} (\nabla u \cdot \nabla v + cuv) \, d\Omega = \int_{\Omega} f v \, d\Omega$$

for all v which are zero on $\partial\Omega$ (Problem (1)). Having partitioned the computational domain into a set of finite elements, known as the mesh, we then seek an approximate solution of the problem on this mesh by restricting ourselves to a finite dimensional subspace, typically a space of piecewise polynomials. Thus we may write down a set of basis functions for the finite dimensional subspace. Then we write our finite element solution as $u_h = \sum_j U_j \phi_j(x)$ where the $\phi_j(x)$ are the finite element basis functions. We then consider problem (1) over the finite dimensional subspace and take in turn $v = \phi_i(x)$ to get

$$\sum_j U_j \int_{\Omega} (\nabla \phi_j \cdot \nabla \phi_i + c \phi_j \phi_i) \, d\Omega = \int_{\Omega} f \phi_i \, d\Omega.$$

This gives rise to the matrix problem $AU = \mathbf{f}$ where

$$a_{ij} = \int_{\Omega} (\nabla \phi_j \cdot \nabla \phi_i + c \phi_j \phi_i) \, d\Omega$$

$$f_i = \int_{\Omega} f \phi_i \, d\Omega.$$

The matrix problem is then solved to give the unknown coefficients U_j . Typically, the basis functions are chosen to be nonzero only on patches of elements so that the matrix A is sparse.

The finite element method was first introduced into the electrochemical literature in the 1990s [ii, iii] to tackle problems in higher spatial dimensions which contained boundary singularities at the interface between electrodes and insulating surfaces in which they are embedded (the so-called \rightarrow "edge-effect"). Since then they have been applied to a wide range of problems in electrochemistry, with examples including transport processes at micro-electrodes (recessed disk electrodes, channel, membrane-covered, etc.) and \rightarrow scanning electrochemical microscopy (SECM) [iv].

The particular advantages of the technique over the more commonly used (in electrochemistry) finite difference methods are: the ability to deal naturally with arbitrary geometries; a strong theoretical underpinning allowing rigorous mesh adaptation strategies to be developed; and the ability to deal with discontinuities at boundaries or internal interfaces.

Refs.: [i] Courant R (1943) *Bull Am Math Soc* 49:1; [ii] Nann T, Heinze J (1999) *Electrochem Commun* 1:289; [iii] Harriman K, Gavaghan DJ,

Houston P, Suli E (2000) *Electrochem Commun* 2:150; [iv] Abercrombie SCB, Denuault G (2003) *Electrochem Commun* 5:647

KG, DG

Finite impulse response filter \rightarrow nonrecursive filter

FIR filter \rightarrow nonrecursive filter

Flade, Friedrich — (Sep. 16, 1880, Arolsen, now Bad Arolsen, Germany – Sep. 5, 1916, near Manancourt, France) After studies of chemistry in Halle and Munich, Flade received his PhD in 1906 from the University of Marburg, Germany. There he qualified as University teacher (habilitation) in 1910 [i]. Flade observed that iron shows a sudden potential change when it goes from the passive to the active state. Now, the electrode potential of a metal where the current associated with the anodic metal dissolution drops to very small values bears his name (\rightarrow potential, subentry \rightarrow Flade potential). He also showed that loading of the iron surface with oxygen is essential for its \rightarrow passivation [ii–vi]. Flade fell in World War I in the Battle of the Somme, and he was buried in Manancourt, France.

Refs.: [i] Auwers K v (1917) *Chem Ztg* 41:105; [ii] Flade F (1911) *Z phys Chem* 76:513; [iii] Flade F Koch H (1912) *Z Elektrochem* 18:334; [iv] Flade F (1913) *Z Elektrochem* 19:808; [v] Flade F, Koch H (1914) *Z phys Chem* 88:307; [vi] Flade F (1914) *Z phys Chem* 88:569

FS

Flade potential \rightarrow potential, subentry \rightarrow Flade potential

Flat-band potential \rightarrow potential, subentry \rightarrow flat-band potential

Flicker-noise \rightarrow noise

Flicker-noise spectroscopy — The spectral density of \rightarrow flicker noise (also known as $1/f$ noise, excess noise, semiconductor noise, low-frequency noise, contact noise, and pink noise) increases with frequency. Flicker noise spectroscopy (FNS) is a relatively new method based on the representation of a nonstationary chaotic signal as a sequence of irregularities (such as spikes, jumps, and discontinuities of derivatives of various orders) that conveys information about the time dynamics of the signal [i–iii]. This is accomplished by analysis of the power spectra and the moments of different orders of the signal. The FNS approach is based on the ideas of deterministic chaos and may be used to identify any chaotic nonstationary signal. Thus, FNS has application to electrochemical systems (\rightarrow noise analysis).

Recent applications of FNS include the dynamics of the electrical potential fluctuation in an electromembrane system [iv], analysis of the fluctuations of the electrical current in electrochemically deposited *→ conducting polymers* [v], and forecasting electrical breakdown in porous silicon [vi].

Refs.: [i] Timashev SF (1993) *Zh Fiz Khim* 67:1755; [ii] Timashev SF (2001) *Russ J Phys Chem* 75:1742; [iii] Timashev SF (2001) *Flicker-noise spectroscopy as a tool for analysis of fluctuations in physical systems*. In: Bosman G (ed) *Noise in physical systems and 1/f fluctuations*. ICNF, World Scientific, New Jersey, pp 775–778; [iv] Timashev SF, Vstovskii GV (2003) *Russ J Electrochem* 39:141; [v] Parkhutik V, Patil R, Harima Y, Matveyeva E (2006) *Electrochim Acta* 51:2656; [vi] Parkhutik V, Rayon E, Ferrer C, Timashev S, Vstovsky G (2003) *Phys Status Solidi A: Applied Research* 197:471

DT

Float charging — A continuous, low-level, constant voltage charging of secondary *→ batteries* (cells), with the purpose of maintaining the battery fully charged, offsetting spontaneous self-discharge or low-level drain. Accomplished by a voltage source, with preset constant voltage bias, the “*→ float voltage*”. This mode of keeping the batteries fully charged is common for standby *→ lead–acid* and *→ nickel–cadmium batteries*. Closely related is the constant low-current *→ trickle charging*.

Refs.: [i] Hammel RO, Salkind AJ, Linden D (1994) *Sealed lead–acid batteries*. In: Linden D (ed) *Handbook of batteries*, 2nd edn. McGraw-Hill, New York, pp 25.29–25.30; [ii] Nagy Z (ed) (2005) *Online electrochemistry dictionary*. <http://electrochem.cwru.edu/ed/dict.htm>; [iii] Crompton TR (2000) *Battery reference book*, 3rd edn. Newnes, Oxford, Chap. 31.14, pp 31.18–31.19

YG

Float voltage — A preset constant voltage used for continuous, low-current, charging of secondary *→ batteries* (cell), with the purpose of maintaining the battery fully charged, offsetting spontaneous *→ self discharge* or low-level drain. The float voltage is supplied by a voltage source. This mode of charging is common for standby *→ lead–acid accumulators* and *→ nickel–cadmium batteries*. The preset float voltage is selected carefully to maintain the battery in its fully charged state, preventing overcharging as much as possible, as it leads to accelerated self-discharge and damages the battery by corrosion, etc. Closely related is the constant, low-current, *→ trickle charging*. See also *→ float charging*.

Refs.: [i] Hammel RO, Salkind AJ, Linden D (1994) *Sealed lead–acid batteries*. In: Linden D (ed) *Handbook of batteries*, 2nd edn. McGraw-Hill, New York, 25.29–25.30; [ii] Nagy Z (ed) (2005) *Online electrochemistry dictionary*. <http://electrochem.cwru.edu/ed/dict.htm>; [iii] Crompton TR

(2000) *Battery reference book*, 3rd edn. Newnes, Oxford, Chap. 49.1 p 49/4

YG

Flooded battery — A battery (or a cell) containing an excess of electrolytic solution (in contrast to starved electrolyte batteries). Usually relevant to rechargeable *→ lead–acid* and *→ nickel–cadmium batteries*. Flooded battery design is typically applicable for heavy duty batteries, equipped with a vent valve that releases pressure buildup due to gas evolution. The excess electrolyte affects more sturdy batteries to become less susceptible to damage due to overcharge. In addition, the thermal conductivity of the electrolyte affords more efficient heat dissipation and thus higher *→ power densities*.

Refs.: [i] Kiehne HA (2003) *Battery technology handbook*. Marcel Dekker, New York, pp 250–252; [ii] Dhameja S (2002) *Electric vehicle battery systems*. Newnes, Butterworth-Heinemann, Boston, pp 6–7; [iii] Gates Energy Products (1998) *Rechargeable batteries applications handbook*. Butterworth-Heinemann, Boston, p 7

YG

Flow-cell (or flow-through cell) — is a device through which fluid may be driven using an external force. Often of rectangular or tubular form for electrochemical applications, a cell may incorporate a variety of different *→ sensors*, e.g., voltammetric [i] or potentiometric [ii], these devices can also be used in conjunction with spectroscopic analysis. Flow-through cells are also used extensively in synthetic and technical applications *→ Swiss-rolle cell*.

See also *→ convection*, *→ Grashof number*, *→ Hagen–Poiseuille*, *→ hydrodynamic electrodes*, *→ laminar flow*, *→ turbulent flow*, *→ Navier–Stokes equation*, *→ Nusselt number*, *→ Peclet number*, *→ Prandtl boundary layer*, *→ Reynolds number*, *→ Stokes–Einstein equation*, *→ wall jet electrode*.

Refs.: [i] Compton RG, Pilkington MBG (1989) *J Chem Soc Faraday Trans 1* 85:2255; [ii] Wang J (1995) *Anal Chem* 67:487R

AF

Flow-through electrodes *→ flow cell*, and *→ hydrodynamic electrodes*

Flowing junction — is a special kind of *→ liquid junction* made in such a way that the two electrolyte solutions forming the junction are flowing in a vertical tube so that the upward flow of the heavier electrolyte meets the downward flow of the lighter electrolyte solution. Lamb and Larson have developed this type of liquid junction and they have discovered that the flowing junction gives

a very constant and reproducible → *liquid junction potential* (reproducible to 10 μV) [i] because the junction is practically of constant nature as long as the flow rate is constant. → MacInnes [ii] improved that system and studied the effect of flow rate on the liquid junction potential.

Refs.: [i] Lamb AB, Larson AT (1920) *J Am Chem Soc* 42:229; [ii] MacInnes DA, Yeh YL (1921) *J Am Chem Soc* 43:2563

FS

Fluidized-bed electrode — A → *three-dimensional electrode* consisting of a bed of individual electronically conducting particles fluidized by an appropriate upward flow of electrolyte. The solid particles/solution system behaves like a single fluid. A perforated distributor through which the electrolyte is admitted to operate the fluidization supports the bed. Current enters (or leaves) the bed *via* metallic feeders (or collectors) in contact with the particulate suspension.

The cells can be conceived with different geometries, namely cylindrical, rectangular or annular but they are always divided by a → *diaphragm*, usually an → *ion-exchange membrane* that separates the working fluidized-bed electrode (FBE) from the other compartment. Generally, the configuration of the cells comply with two extreme arrangements: “flow-through”, when current and electrolyte flows are parallel, or the most utilized in practice “flow-by”, where those flows are perpendicular.

The attractiveness of the FBE relies on the large specific area (area/unit volume) providing very low current densities on the particles’ surfaces, thus allowing high mass transfer rates and regular flow distribution. Relevant characteristics of the electrochemical reactors using this kind of electrodes are the non-uniform potential (hence the current distribution within the bed), electrolyte concentration, current efficiency, and specific energy consumption. Major factors in the performance of FBEs are the particle size, flow rate, bed expansion, and bed thickness. Potential applications include organic → *electrosynthesis*, metal recovery and pollution abatement from metal-containing effluents, electroleaching of sulfide ores, or even primary metal → *electrowinning* from ore leach solutions. When the FBE is used for metal reclamation, continuous operation can be achieved with periodical withdrawal of grown particles at the bottom of the cell and addition of original fine particles at the top of the bed. The drawbacks of FBEs are: continuous fluctuation of particles size and weight; formation of inactive zones; bad electrical conduction in highly expanded beds; damage of diaphragms caused by

local deposition; particles agglomeration; particles behaving as bipolar due to mutual touching or contact with the current feeders.

Refs.: [i] Pletcher D, Walsh FC (1990) *Industrial electrochemistry*, 2nd edn. Chapman and Hall, London; [ii] Rajeshwar K, Ibanez JC (1997) *Environmental electrochemistry, fundamentals and applications in pollution abatement*. Academic Press, San Diego; [iii] Walsh FC (1993) *A first course in electrochemical engineering*. The electrochemical Consultancy, Romsey, Hants

LMA

Fluorescent indicator — A substance that shows definite changes in fluorescence with a change in pH. This kind of indicator is especially useful for the titration of opaque, highly turbid, or deeply colored solutions. A long-wavelength ultraviolet lamp in a dimly lighted room provides the best environment for titrations involving fluorescent indicators [i].

Ref.: [i] Skoog D, West D, Holler F (1996) *Fundamentals of analytical chemistry*. Saunders College Publishing, New York

FG

Fluoride anion conductors → *solid electrolyte*

Fluoride conducting solid electrolyte → *solid electrolyte*

Fluorine production by electrolysis → *Moissan*, and → *Fredenhagen*

Fluorine-doped tin oxide → *FTO*

FNS → *flicker-noise spectroscopy*

Formal potential → *potential*

Foerster, Fritz



(Courtesy of Universitätsarchiv der TU Dresden, Fotoarchiv)

(Feb. 22, 1866, Grünberg, Germany, now Zielona Góra, Poland – Sep. 14, 1931, Dresden, Germany) Foerster studied chemistry at the University of Berlin from 1884–88

where he attended lectures given by → *Helmholtz*, and → *du Bois-Reymond*. Ph.D. from the University of Berlin in 1888, 1894 habilitation at ‘Technische Hochschule’ of Berlin (now Technical University). From 1895 on at the ‘Technische Hochschule Dresden’ (now Technical University) (1898 extraordinary, 1900 ordinary professor) [i]. Foerster made various contributions to technical electrochemistry, founded the electrochemical school in Dresden, and was most influential by his textbook on the electrochemistry of aqueous solutions [ii]. Foerster also contributed to the analysis of glasses and developed various new methods which he published in a series of papers with the title ‘Elektroanalytik’ (→ *electroanalysis*) [iii].

Ref.: [i] Müller E (1932) *Z Anorg allg Chem* 204:1; [ii] Foerster F (1905) *Elektrochemie wässriger Lösungen*. In: Bredig G (ed) *Handbuch der angewandten physikalischen Chemie*, Band 1. J Ambrosius Barth, Leipzig; [iii] Foerster F (1908) *Z Elektrochem* 14:3; [iv] Foerster F (1908) *Z Elektrochem* 14:17; [v] Foerster F (1908) *Z Elektrochem* 14:90; [vi] Foerster F (1916) *Z Elektrochem* 10:26; [vii] Foerster F (1910) *Z Elektrochem* 16:980

FS

Four-electrode system — For electrochemical measurements with the → *interface between two immiscible electrolyte solutions* (or the → *oil/water interface*), the four-electrode system is used. In potentiostatic measurements such as cyclic voltammetry, two reference elec-

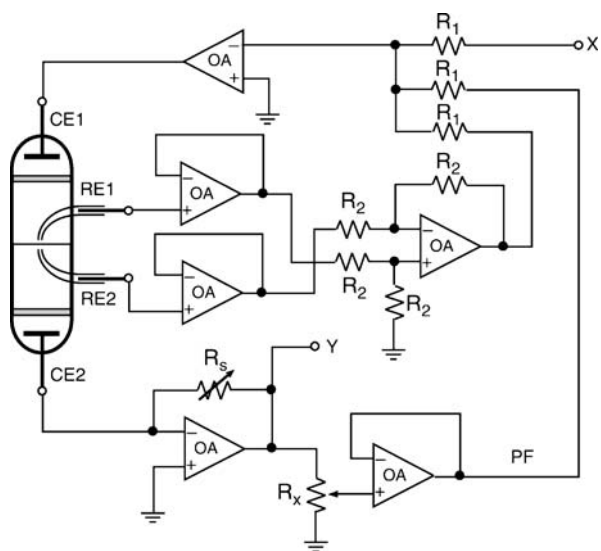

Four-electrode system — **Figure.** Electronic circuit of a four-electrode potentiostat (X, potential input; Y, current output; RE1 and RE2, reference electrodes; CE1 and CE2, counter electrodes; PF, positive feedback circuit for IR drop compensation)

trodes immersed in the oil and water phases are used for controlling the potential difference of the interface, while two counter electrodes immersed in the respective phases are used for detecting the current flowing through the interface. For such measurements, a four-electrode → *potentiostat* (or → *galvanostat*) is necessary. A simplified electronic circuit of a four-electrode potentiostat is shown in the figure. Four-electrode configurations are also used in → *SECM* and → *rotating ring disk electrode* measurements, but for these measurements, a → *bipotentiostat* is used, whose electronic circuit and function are different from those shown here. See also → *three-electrode system*, → *positive feedback circuit*.

Ref.: [i] Samec Z, Marecek V, Weber J (1979) *J Electroanal Chem* 100:841

TO

Four-electrode technique for conductivity measurements — involves passing an electrical → *current* between two → *electrodes* and measuring the corresponding → *voltage* drop between two other electrodes (potential probes), provided that the system can be described by a certain solution of → *Ohm's law* for given boundary conditions. This method makes it possible to avoid errors due to non-negligible electrode → *polarization* and, often, nonuniform current distribution in the → *conductivity cell*. Although a number of various configurations are known, in most cases the potential probes are placed between the current probes (electrodes to which an external voltage is applied). In such a simplest case illustrated in the figure, when the linear one-dimensional solution of the Ohm's law is applicable, the conductivity

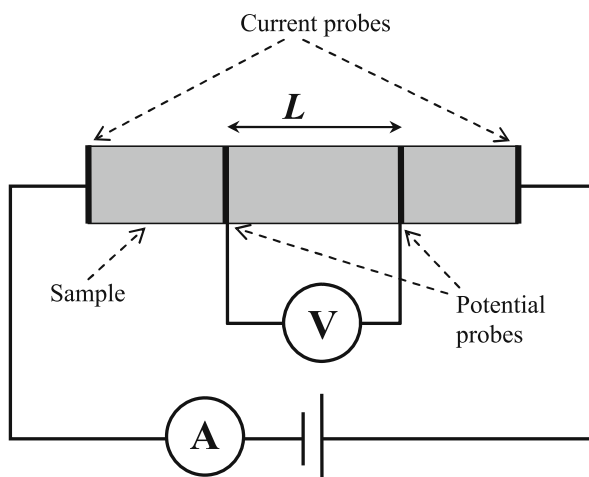

Four-electrode technique for conductivity measurements — **Figure.** One possible electrode arrangement for the four-probe conductivity measurements, used often in solid-state electrochemistry

can be calculated as

$$\chi = \frac{I}{U} \cdot \frac{L}{A},$$

where L corresponds to the distance between the potential probes. A similar approach can be applied for the determination of partial ionic and electronic conductivities in conducting solids, using electron- or ion-blocking electrodes. See also: → *Hebb–Wagner technique*, → *diffusion (determination in solids)*, → *impedance spectroscopy*.

Refs.: [i] Bagotsky VS (2005) *Fundamentals of electrochemistry*, 2nd edn. Wiley, New York; [ii] Van der Pauw L (1958) *Phillips Res Rep* 13:1; [iii] Van Herle J, McEvoy AJ, Thampi RK (1994) *J Mater Sci* 29:3691; [iv] Kröger FA (1964) *The chemistry of imperfect crystals*. North-Holland, Amsterdam

VK

Fourier transformation — In common with many other technologies, electrochemical instruments nowadays produce data in the form of a “time series” – a large array of numbers equally spaced in time. As an alternative to inspecting the data – usually electric current in electrochemical applications – in its raw time-series form, an alternative is to determine the amplitudes of the sinusoidal frequencies present in the signal. Fourier transformation is the procedure by which the time series is analyzed into its component frequencies. This task is delegated to a computer, usually through a “fast Fourier transform” or FFT program.

In electrochemistry, Fourier transformation is usually applied to the current resulting when a periodic (often sine-wave or square-wave) voltage is imposed on a cell. This may be the only signal applied, as in → *impedance spectroscopy* or the periodic voltage may modulate an aperiodic (“DC”) potential as in → *AC voltammetry* or → *square-wave voltammetry*.

Refs.: [i] Barsoukov E, Macdonald JR (eds) (2005) *Impedance spectroscopy, theory, experiment and applications*, 2nd edn. Wiley, New York; [ii] Hazi J, Elton DM, Czerwinski WA, Schiewe J, Vincente-Beckett VA, Bond AM (1983) *J Electroanal Chem* 9:87

KBO

Fourier transform voltammetry — Analysis of any AC or transient response using (fast) Fourier transformation (FFT) and inverse (fast) Fourier transformation (IFFT) to convert time domain data to the frequency domain data and then (often) back to time domain data but separated into DC and individual frequency components [i–ii]. See also → *Fourier transformation*, → *AC voltammetry*, → *AC polarography*.

Refs.: [i] Smith DE (1976) *Anal Chem* 48:221A; [ii] Bond AM, Duffy NW, Guo S, Zhang J, Elton D (2005) *Anal Chem* 77:186A

AMB

Fowler–Frumkin isotherm → *Frumkin adsorption isotherm*

FRA → *frequency*, subentry → *frequency response analyzer*

Fractals in electrochemistry — Fractals [i] are geometrical objects whose most obvious feature is their blow-up symmetry: their smaller-and-smaller details are similar to each other: scale invariance or self-similarity is observed. In general, the extent of a geometrical structure is characterized by covering the structure with D -dimensional cubes of size ε , counting the number of cubes, $N(\varepsilon)$, and calculating $N(\varepsilon)\varepsilon^D$ product. This product becomes independent of ε at low ε only if an appropriate D value has been chosen. Whereas for conventional geometrical objects, D is 1, 2, or 3; for fractals, D is usually a non-integer number in the full range of 0 to 3, referred to as fractal dimension, D_f . A typical example of fractals is the famous von Koch curve (Figure).

In electrochemistry, fractals play a role in the context of two subjects:

- During → *electrodeposition* of metals, under certain conditions the deposit forms dendrites: needles, whiskers, branched structures, rather than a dense smooth layer. In these cases the shape of the deposits may be modeled by fractals; theories on phase formation kinetics can be checked by comparison with the “fractal growth” during electrodeposition experiments.
- Since many solid surfaces can be approximated as fractals, rough, porous, and partially active → *elec-*

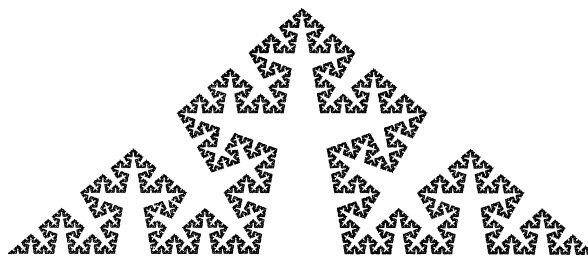

Fractals in electrochemistry — **Figure.** A von Koch curve of $D_f = 1.5$. Note that no characteristic length of the structures can be identified – this is associated with the fact that the size-distribution of the features of the curves is a power-law function

trodes may also be modeled by fractals. It is instructive to generalize the concepts and laws of electrode kinetics – which were introduced or derived by tacitly assuming that the electrode geometry is planar or of some other simple (e.g., spherical) form – for the cases of fractal interfaces. Such generalizations lead to the following statements [ii]:

1. The \rightarrow *impedance* of a planar capacitive electrode immersed in a resistive solution conforms to that of a serial R–C circuit. If the geometry of the capacitive electrode is some fractal, then the electrode impedance, $Z(\omega)$, is a \rightarrow *CPE*, $Z = \text{const} \cdot (i\omega)^{-n}$, and the exponent n – depending on the actual form of the fractal – is some function of D_f .
2. The time decay of the \rightarrow *diffusion*-limited current to a planar electrode under semi-infinite diffusion conditions is expressed by the \rightarrow *Cottrell-equation*, that is, $j = \text{const} \cdot t^{-1/2}$. If the diffusion proceeds towards an electrode which is fractal in a certain size range, then the exponent changes to $-(D_f - 1)/2$, in a corresponding time range. In the similar vein, the exponent of $(i\omega)$ in the expression of the \rightarrow *Warburg impedance* also changes to $-(D_f - 1)/2$ in the case of an electrode of fractal geometry.

In both cases the time (or frequency) functions become power-law functions of time (or frequency) indicating that the measured current or impedance involve no characteristic time (or frequency) with fractals – which have no characteristic sizes.

Refs.: [i] Mandelbrot BB (1982) *The fractal geometry of nature*. Freeman, San Francisco; [ii] Pajkossy T (1995) *Heterogen Chem Rev* 2:143

TP

Frank-van der Merwe heteroepitaxial metal deposition \rightarrow epitaxial metal deposition

Fray–Farthing–Chen Process — Metal winning by \rightarrow *electrolysis* of solid metal oxides, e.g., TiO_2 and Tb_4O_7 , dispersed in molten salts, e.g., CaCl_2 [i, ii]. The technology is still under development.

Ref.: [i] Fray DJ, Farthing TW, Chen GZ (1999) *Removal of oxygen from metal oxides and solid solutions by electrolysis in a fused salt*, World Patent 99/64638; [ii] Wang D, Qiu G, Jin X, Hu X, Chen GZ (2006) *Angew Chem Int Ed* 45:2384

FS

Fredenhagen, Karl (Carl)



(May 11, 1877, Loitz, Germany – April 4, 1949, Greifswald, Germany) Fredenhagen studied science in Hannover, Darmstadt, Leipzig, and Göttingen from 1896 to 1899. In 1901 he received a Ph.D. from the University of Göttingen where he worked with \rightarrow *Nernst*. From 1903 to 1923 he was at the University of Leipzig as assistant, docent, and finally professor. From 1923 to 1945 he was professor of physical chemistry at the University of Greifswald. Fredenhagen studied aqueous and nonaqueous electrolyte solutions (especially solutions in liquid anhydrous HF, e.g. [ii–iii], and ref. in [iv]), and he developed a method to produce elementary fluorine by \rightarrow *electrolysis* of molten KH_2F_3 in which the temperature can be kept at 50 °C (see also \rightarrow *Moissan*). Fredenhagen realized in his studies that there are distinctly different series of \rightarrow *standard electrode potentials* of the elements for different \rightarrow *solvents*.

Refs.: [i] Fredenhagen C (1902) *Zur Theorie der Oxydations- und Reduktionsketten*. Ph.D. thesis, Göttingen; [ii] Fredenhagen K, Fredenhagen H (1939) *Z anorg allg Chem* 243:42; [iii] Fredenhagen K, Cadenbach G (1931) *Z Elektrochem* 37:684; [iv] Jander G (1949) *Die Chemie in wasserähnlichen Lösungsmitteln*. Springer, Berlin

FS

Free energy \rightarrow Gibbs energy

Free energy of ion transfer \rightarrow *ion transfer at liquid-liquid interfaces*

Free energy relationship \rightarrow *linear free energy relationship (LFER)*

Free surface charge density \rightarrow *Gibbs–Lippmann equation*

Frenkel, Yakov Il'ich



(Feb. 10, 1894, Rostov-on-Don, Russia – Jan. 23, 1952, Leningrad, USSR, now St. Petersburg, Russia) Frenkel entered St. Petersburg University in 1910 and graduated from the Physics and Mathematics Department after 3 years. After some time teaching in Simferopol, from 1921 till the end of his life he worked at the Physico-Technical Institute in St. Petersburg (which was evacuated to Kazan during WW II). In 1925 he started out for a one-year tour around Europe. Frenkel was extremely productive in writing physics books. For solid-state science his introduction of the hole as a \rightarrow *defect* in solids [i] and also of the \rightarrow *exciton* is of special importance.

Refs.: [i] Frenkel J (1926) *Z Phys* 35:652; [ii] Obituary: Yakov Il'ic Frenkel (1952) *Akad Nauk SSSR. Zh Ekspert Teoret Fiz* 23:613

Frenkel defects \rightarrow defects in solids

Frequency — In general, frequency is the rate at which a happening or phenomenon recurs, measured as the number of cycles or completed alternations per unit time. In electrochemistry, it usually refers to the number of complete cycles per second in some periodic current or voltage oscillation. Such oscillations are often sinusoidal in shape, but may have other wave shapes such as square wave, triangle wave, etc. The frequency f (in cycles per second or hertz, Hz) is equal to the reciprocal of the period of the waveform T_P (in s). The period (T_P) is the time required to complete one complete cycle of the oscillation, as illustrated for a sine wave in the figure below (where $T_P = 0.100$ s).

Sometimes the angular frequency ω is used. This definition of frequency refers to the rate of rotation of a vector (or phasor) about the origin in the complex plane. The projection of the unit vector on the imaginary (vertical) axis gives rise to the sine wave shown in the figure. Angular frequency ω in Hz is the magnitude of the angular velocity (in radians per second) of the vector and

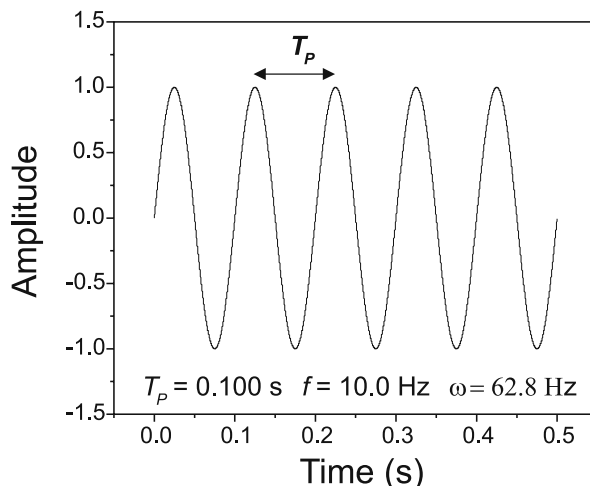

Frequency — Figure

is related to f by the relationship $\omega = 2\pi f$. Thus, the frequency of the sine wave in the figure may be specified either as $f = 10.0$ Hz or as $\omega = 62.8$ Hz.

DT

Analysis — Any arbitrary time-dependent function may be synthesized by adding together sine and cosine functions of different frequencies and amplitudes, a process known as synthesis [i]. Conversely, the determination of the amplitudes and frequencies of the sine and cosine waves that make up a time-dependent signal (or noise), for example $v(t)$ or $I(t)$, is known as analysis (or decomposition). Thus, for a signal defined over some time period T , analysis results in the determination of the amplitudes a_n and b_m as a function of frequency in the expression

$$v(t) = \frac{a_0}{2} + \sum_{n=1}^{\infty} a_n \sin(2\pi n f_1 t) + \sum_{m=1}^{\infty} b_m \cos(2\pi m f_1 t)$$

or, equivalently, the amplitudes a_n and phases ϕ_n in the expression

$$v(t) = \frac{a_0}{2} + \sum_{n=1}^{\infty} a_n \sin(2\pi n f_1 t + \phi_n),$$

where the $a_0/2$ term is the average DC level of the signal and $n f_1$ and $m f_1$ are the frequencies of the components, with the fundamental frequency $f_1 = 1/T$. More compact representations using complex notation are available [i]. The result of such an analysis is a spectrum whereby amplitudes and/or phases are plotted as a function of frequency. Such analyses are most often performed using the \rightarrow *Fourier transformation*, although other approaches such as maximum entropy spectral analysis

and wavelet analysis are used, particularly for nonstationary signals whose spectral composition (i.e., a_n , ϕ_n , f_n) vary over long periods of time.

Ref.: [i] Simpson RE (1987) *Introductory electronics for scientists and engineers*, 2nd edn. Allyn and Bacon, Boston, Chap. 3

DT

Audio-bridge — An unknown \rightarrow impedance may be determined by placing the impedance element in a bridge circuit as indicated in the figure below, where Z_U represents the unknown impedance element (e.g., an electrochemical cell). The other impedances in the bridge circuit (Z_1 , Z_2 , and Z_3) are high-quality calibrated components, at least one of which can be adjusted in value (Z_2 in the figure). A fixed frequency signal that falls within the audio range (e.g., 50 Hz–10 kHz) is applied to the bridge and, while listening to the headphones or a speaker, one (or more) of the impedance “arms” of the bridge is adjusted. A balance is realized when the headphones fail to produce “clicks” or tones as the switch is activated, at which point the impedance of the unknown element is given by

$$Z_U = \frac{Z_3}{Z_1 Z_2}.$$

In general, all the impedances in the figure and in the above equation are complex quantities, accounting for both magnitude and phase angle. The measurement can be repeated at each of several frequencies throughout the audio frequency range, providing an \rightarrow impedance spectrum of Z_U . Bridge methods are labor intensive and very slow, difficult to use for frequencies below about 1 Hz, and preclude the use of a \rightarrow three electrode system. In general, direct methods (e.g., see \rightarrow frequency response analyzer) can be used to acquire impedance data more rapidly than bridge methods.

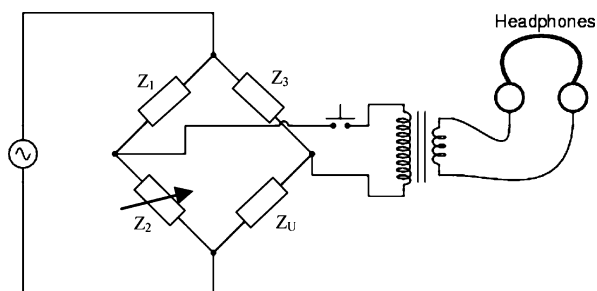

Frequency — Audio-bridge — Figure

DT

Domain — Most signals in the laboratory are acquired in the \rightarrow time domain, that is, as a current or

voltage that changes over time. Such signals can be converted to the frequency domain by a suitable transform technique, such as the \rightarrow Fourier transformation, resulting in a graph that shows the composition of the signal (i.e., amplitude and/or phase) at each given frequency over a range of frequencies. This conversion process is called \rightarrow analysis. These two representations of a signal, ‘time domain’ and ‘frequency domain’, are entirely equivalent. Some instruments display the data in the frequency domain as in \rightarrow electrochemical impedance spectroscopy, where the time domain data is converted to the frequency domain using a \rightarrow frequency response analyzer. Digital filtering can be accomplished by transformation of time domain data to the frequency domain where specific (noise) frequencies can be removed, followed by inverse transformation back to the time domain [i]. AC circuit analysis is often much easier in the frequency domain since algebraic equations arise rather than the differential equations encountered in the time domain [ii].

Refs.: [i] Simpson RE (1987) *Introductory electronics for scientists and engineers*, 2nd edn. Allyn and Bacon, Boston, Chap. 16; [ii] *ibid.* Chap. 2

DT

Dispersion — Frequency dispersion results from different frequencies propagating at different speeds through a material. For example, in the \rightarrow electrochemical impedance spectroscopy (EIS) of a crevice (or porous) electrode, the solution resistance, the charge transfer resistance, and the capacitance of the electric double layer often vary with position in the crevice (or pore). The impedance displays frequency dispersion in the high frequency range due to variations in the current distribution within the crevice (pore). Additionally, EIS measurements in thin layer cells (such as \rightarrow electrochromic devices, \rightarrow conducting polymer-coated electrodes, \rightarrow ion-exchange membranes, or any type of \rightarrow diffusion layer which exerts some hindrance to \rightarrow mass transport at the boundaries) display frequency dispersion in the low frequency range due to a mixture of ‘volume’ and ‘boundary’ properties of the layer influencing the response. At solid metal/electrolyte interfaces, the frequency dispersion is commonly attributed to a nonuniform distribution of the electric charge (and, thus, also of the current density) due to the roughness and/or heterogeneity of the solid electrode surface. These behaviors are usually modeled by a \rightarrow constant phase element or a \rightarrow transmission line element [i]. Dispersion of the \rightarrow (dielectric) permittivity of materials is often observed, for example, in the two-electrode impedance (dielectric) spectroscopy of materials that show a space-charge limited response [i].

Ref.: [i] Barsoukov E, Macdonald JR (eds) (2005) *Impedance spectroscopy: Theory, experiment, and applications*, 2nd edn. Wiley, Hoboken, Chap. 2

DT

Radio-bridge — A bridge circuit similar to the → *audio-bridge* except the signal source produces frequencies in the radio frequency range (e.g., 50 kHz–50 MHz) and a radio receiver (or even an oscilloscope) is used to determine the condition of null.

DT

Response analyzer, potentiostatic — There are various approaches to obtaining an electrochemical impedance spectrum. The most common involve perturbing the sample with one or more small amplitude (usually a few mV) sinusoidal potential variation(s) superimposed on a base (or DC) potential. The perturbation may be applied one frequency at a time (single sine) or with several frequencies applied simultaneously (multi sine). Analysis of the current response can then be accomplished in the time domain (e.g., with the multi sine approach using Fourier transform methods) or in the frequency domain (single sine) using a frequency response analyzer (or FRA) [i]. The potentiostatic FRA holds the base potential constant and varies the frequency of the perturbation over some range. At each frequency, the FRA multiplies the current response by a reference sine wave and also by a reference cosine wave, each derived from the same signal source that supplies the sample perturbation, and these products are integrated over a whole number of cycles. This process provides the in-phase (real) and out-of-phase (imaginary) components of the impedance, respectively, while rejecting any harmonic responses and significantly reducing random noise. The FRA process can be carried out in the digital domain using software or in the analog domain using hardware. Alternatively, the applied perturbation could be a current and the measured response a potential (galvanostatic EIS).

Ref.: [i] Bard AJ, Faulkner LR (2001) *Electrochemical methods*, 2nd edn. Wiley, New York, Chap. 10

DT

Transformation — Several approaches are available for transformation of → *time domain* data into the → *frequency domain*, including → *Fourier transformation*, the maximum entropy method (MEM) [i], and wavelet analysis [ii]. The latter two methods are particularly useful for nonstationary signals whose spectral composition vary over long periods of time or that exhibit transient or intermittent behavior or for time records with unevenly sampled data. In contrast to Fourier transformation which looks for perfect sine

waves in the data, MEM looks for a best fit solution and, thus, has the ability to handle more complex periodic phenomena. For example, MEM has been applied to analysis of electrochemical noise data [iii]. Wavelet analysis extracts both the time evolution and the frequency composition of a signal [ii].

Refs.: [i] Press WH, Brian PF, Teukolsky SA, Vetterling WT (1992) *Numerical recipes in C*, 2nd edn. Cambridge University Press, Cambridge; [ii] Newland DE (1993) *An introduction to random vibrations, spectral and wavelet analysis*. Longman Scientific & Technical, New York; [iii] Bierwagen GP, Wang X, Tallman DE (2003) *Prog Org Coatings* 46:163

DT

Freundlich, Herbert Max Finlay



(Reproduced with permission of 'Archiv der Max-Planck-Gesellschaft, Berlin-Dahlem')

(Jan. 28, 1880, Berlin, Germany – Mar. 30, 1941, Minneapolis, USA) Freundlich studied chemistry in Munich and Leipzig, and received his Ph.D. in 1903 (Leipzig). Later he was assistant of → *Ostwald, F.W.* In 1906 he habilitated [i], i.e., he qualified as university teacher of physical and inorganic chemistry. In 1911 he became assistant professor in Brunswick (Braunschweig, Germany). In 1916 he joined the group of → *Haber* at the “Kaiser-Wilhelm-Institut” of physical chemistry in Berlin where he became deputy director in 1919. Because he and also Haber were ordered by the Nazi regime in 1933 to dismiss all ‘non-Aryan’ collaborators, they both resigned from all their positions in Berlin, and Freundlich left Germany for the UK. He was invited by → *Donnan* to work at University College, London. After some years of work there, he went to the US in 1937/38 as guest professor, and became professor of colloid chemistry in 1938 in Minneapolis. Freundlich studied various colloidal systems, discovered magnetic thixotropy, and performed electrophoretic studies of colloids. Freundlich is best known for the → *Freundlich adsorption isotherm*. Among the various publications of Freundlich, his book on capillary chemistry was most influential [ii]. For more biographic details see [iii].

Refs.: [i] Freundlich H (1906) *Über die Adsorption in Lösungen* (On the adsorption in solutions). Wilhelm Engelmann, Leipzig; [ii] Freundlich H (1909) *Kapillarchemie. Eine Darstellung der Chemie der Kolloide und verwandter Gebiete*. Akademische Verlagsgesellschaft, Leipzig, (4th German edn. in 2 vols, 1930–32); Engl transl: Freundlich H (1926) *Colloid & capillary chemistry*. Methuen, London; [iii] Donnan FG (1942) Obituary Notices of Fellows of the Royal Society 4:27

FS

Freundlich adsorption isotherm — The empirical adsorption isotherm $\Theta = bc^n$ (Θ surface coverage, b and n are constant, $0 < n < 1$, and c is the solution concentration) was initially proposed by Boedecker in 1895 [i], however it was popularized by \rightarrow Freundlich [ii], and today is generally referred to as the Freundlich adsorption isotherm [iii].

Refs.: [i] Boedecker C (1895) *J Landw* 7:48; [ii] Freundlich H (1909) *Kapillarchemie. Eine Darstellung der Chemie der Kolloide und verwandter Gebiete*. Akademische Verlagsgesellschaft, Leipzig, (4th German edn. in 2 vols 1930–32); Engl transl: Freundlich H (1926) *Colloid & capillary chemistry*. Methuen, London; [iii] Ościk J (1982) *Adsorption*. PWN, Warsaw, Ellis Horwood, Chichester

FS

Friction coefficient \rightarrow electrophoresis, subentry \rightarrow electrophoretic mobility

Friedel oscillations — Oscillations of the electronic density caused by a disturbance such as a surface or an excess charge. At surfaces, they decay asymptotically with $1/z^2$, where z is the distance from the surface. Within electrochemistry they play a role in \rightarrow double-layer theories that represent the metal as \rightarrow jellium.

Refs.: [i] Blandin A, Daniel E, Friedel J (1959) *Philos Mag* 4:180; [ii] Lundquist S, March NH (eds) (1983) *Theory of the inhomogeneous*

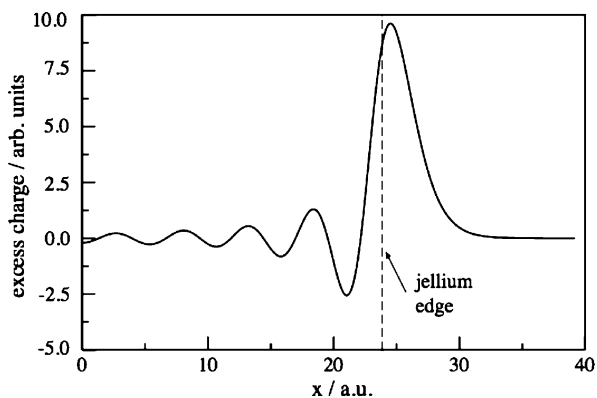

Friedel oscillations — Figure

electron gas. Plenum Press, New York; [iii] Schmickler W, Henderson D (1986) *Prog Surf Sci* 22:323

WS

Frost–Ebsworth diagrams — Frost [i] and Ebsworth [ii] have suggested a graphical way to present the redox properties of elements and compounds by plotting nE^\ominus (n is the number of transferred \rightarrow electrons, and E^\ominus is the \rightarrow standard potential) versus the oxidation number of the element [iii]. Since $nE^\ominus = -\Delta G^\ominus / F$ (ΔG^\ominus is the standard \rightarrow Gibbs energy, and F the \rightarrow Faraday constant) the plot visualizes the changes in Gibbs energies from one oxidation state to the other. It is important that all plotted nE^\ominus values refer to the oxidation state 0. Since mostly the standard potentials are given for successive redox transformation, e.g., for the couple $\text{MnO}_2/\text{Mn}^{2+}$, and not for the couple MnO_2/Mn , the necessary values have to be computed from the tabulated standard potentials using \rightarrow Luther's rule. The figure gives the Frost–Ebsworth diagram for some oxidation states of manganese. Further it is important that for one diagram all standard potentials have to relate either to acidic or to alkaline conditions, and should never be mixed.

FS

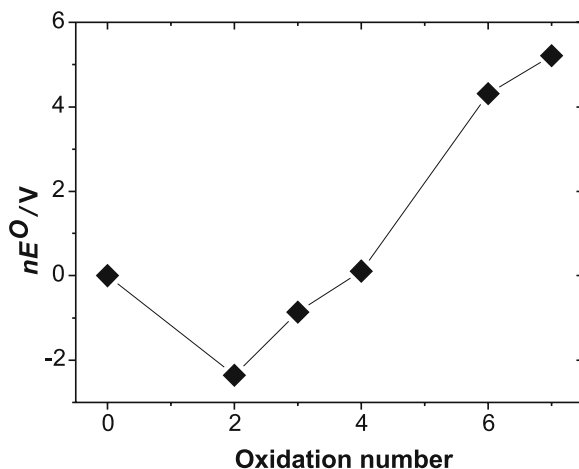

Frost–Ebsworth diagrams — Figure

Refs.: [i] Frost AA (1951) *J Am Chem Soc* 73:2680; [ii] Ebsworth EAV (1964) *Educ Chem* 1:123; [iii] Housecroft CE, Sharpe AG (2005) *Inorganic chemistry*, 2nd edn. Pearson, UK

FS

Frozen solution voltammetry — Electrochemistry (usually voltammetry) in frozen media (e.g., frozen aqueous perchloric acid) [i].

Refs.: [i] Stimming U, Schmickler W (1983) *J Electroanal Chem* 150:125

AMB

Frumkin, Alexander Naumovich



F

(Oct. 24, 1895, Kishinev, Russia, now Chişinău, Moldova – May 27, 1976, Moscow, USSR, now Russia) After graduating from the technical college in Odessa (1912) and probation in Straßburg and Bern, he had taken an external degree of Novorossiisk University (1915). The early studies of Frumkin of → *electrocapillary* phenomena at electrified interfaces (thesis, 1919) determined his future key directions in electrochemistry and colloid chemistry, continued later in Moscow: in the Karpov Physico-chemical Institute (starting from 1922), Moscow University (starting from 1930; in 1933 he founded the Dept. of Electrochemistry there), and in the Institute of Colloid Chemistry and Electrochemistry later transformed into the Institute of Physical Chemistry. Finally, in 1958 Frumkin founded the Institute of Electrochemistry of the USSR Academy of Sciences, and headed it up to his death.

The Frumkin epoch in electrochemistry [i–iii] commemorates the interplay of electrochemical kinetics and equilibrium interfacial phenomena. The most famous findings are the → *Frumkin adsorption isotherm* (1925) → *Frumkin's slow discharge theory* (1933, see also → *Frumkin correction*), the → *rotating ring disk electrode* (1959), and various aspects of surface thermodynamics related to the notion of the → *point of zero charge*. His contributions to the theory of → *polarographic maxima*, kinetics of multi-step electrode reactions, and corrosion science are also well-known. An important feature of the Frumkin school was the development of numerous original experimental techniques for certain problems. The Frumkin school also pioneered the experimental style of ultra-pure conditions in electrochemical experiments [i]. A list of publications of Frumkin until 1965 is available in [iv], and later publications are listed in [ii].

Refs.: [i] Bockris JO'M (1977) *Proc R Austral Chem Inst*, p 19; [ii] (1975) *J Electroanal Chem* 65:1; [iii] Parsons R (1976) *J Electroanal Chem* 74:1; [iv] (1965) *J Electroanal Chem* 10:351

OP, GT

Frumkin coefficient → *Frumkin isotherm*

Frumkin isotherm — is a frequently observed dependence of the surface adsorbate concentration or surface coverage θ on the bulk concentration $c_i^{(b)}$ of neutral organic molecules:

$$\beta c_i^{(b)} = \frac{\theta}{1 - \theta} \exp(-2a\theta),$$

where β is the constant of adsorption equilibrium, and a is the so-called attraction (interaction) coefficient (a is also called Frumkin coefficient). The value of $\ln \beta$ characterizes the free adsorption energy ΔG_A^\ominus :

$$-\Delta G_A^\ominus = \text{const} + RT \ln \beta,$$

where the value of const depends on the choice of the standard state. The attraction coefficient reflects the set of lateral interactions between the molecules of adsorbate A and solvent S in the surface layer:

$$a = (-\Delta G_{AA} + \Delta G_{AS} - \Delta G_{SS}) / RT.$$

The ΔG_A^\ominus , ΔG_{AA} , ΔG_{AS} , and ΔG_{SS} values, and, correspondingly, $\ln \beta$ and a values depend on the electric state of the surface, i.e., on the electrode potential or charge. This isotherm was deduced by Frumkin [i] (and named after him soon) as a general case of the → *Langmuir isotherm*, which corresponds to $a = 0$. A statistical derivation of the Frumkin isotherm is available [ii]; various model considerations and relations to other types of isotherms are discussed in [iii]. Another typical form of the Frumkin isotherm is

$$\beta c_i^{(b)} = \frac{\theta}{1 - \theta} \exp(g\theta),$$

with interaction coefficient $g = -2a$ (in contrast to the original form of the isotherm, the sign of g agrees with the repulsion/attraction sign accepted in physics). The Frumkin isotherm can be extended to three-dimensional systems (the so-called intercalation Frumkin isotherm [iv]). Applications of the Frumkin isotherm to real systems has been discussed in detail in [v].

See also → *adsorption*, → *adsorption isotherm*, → *Frensdlich adsorption isotherm*, → *Langmuir adsorption isotherm*, → *Markin–Volkov isotherm*.

Refs.: [i] Frumkin A (1925) *Z phys Chem* 116:466; [ii] Fowler R, Guggenheim EA (1956) *Statistical mechanics*. Cambridge University Press, Cambridge; [iii] Parsons R (1964) *J Electroanal Chem* 7:136; [iv] Levi MD,

Aurbach D (1999) *Electrochim Acta* 45:167; Nikitas P (1994) *J Electroanal Chem* 375:319; [v] Damaskin BB, Petrii OA, Batrakov VV (1971) *Adsorption of organic compounds on the electrodes*. Plenum Press, New York (German translation: (1975) Akademie Verlag, Berlin)

OP

Frumkin correction — is the procedure of experimental data treatment aimed at extracting the dependence of \rightarrow reaction rate (current) on the electrode potential in the absence of distortions induced by electrostatic reactant-electrode interactions. The idea of F. correction follows from the \rightarrow Frumkin's slow discharge theory operating with a model parameter ψ_1 (named originally psi-prime potential and having a meaning of potential in the point of reactant location). In the framework of this theory, the \rightarrow Tafel plots are expected to be independent of the supporting electrolyte concentration in the following form (so-called corrected Tafel plots, first introduced in [i]): $(\ln j + \frac{z_0 F}{RT} \psi_1)$ vs. $(\eta - \psi_1)$, where j is the current density, η is the overvoltage, z_0 is the charge of the reacting species. Equilibrium double layer is assumed, with \rightarrow Boltzmann distribution of charged species governed exclusively by electrostatic interaction with the electrode surface. The absence of the exact coincidence of data for various solutions is usually considered as a manifestation of an incorrect choice of the ψ_1 value [i, ii]. It can result from large size and/or asymmetry of the real reactant and/or from the existence of a non-electrostatic component of reactant-electrode interaction (\rightarrow specific adsorption). The linearity of the corrected Tafel plots (assumed indirectly in \rightarrow Frumkin's slow discharge theory) can be considered as reliable criteria only when the \rightarrow symmetry coefficient α is independent of potential. Correspondingly, there are no exact criteria to find unambiguous combinations of ψ_1 and α using the classical version of the Frumkin correction. A similar procedure based on \rightarrow Marcus theory [iii] provides more certain determination of model parameters. The meaning of the ψ_1 potential can be better understood at the molecular level by means of considering the interaction of finite size reactant with the electrode with taking into account real charge distribution inside the reactant species [iv].

Refs.: [i] Asada K, Delahay P, Sundaram AK (1961) *J Am Chem Soc* 83:3396; [ii] Delahay P (1965) *Double layer and electrode kinetics*. Interscience, New York, chap IX; [iii] Zagrebina PA, Tsirlina GA, Nazmutdinov RR, Petrii OA, Probst M (2006) *J Solid State Electrochem* 10:157; [iv] Nazmutdinov RR, Tsirlina GA, Petrii OA, Kharkats YuI, Kuznetsov AM (2000) *Electrochim Acta* 45:3521

GT, OP

Frumkin effect \rightarrow double layer, effect on charge transfer rate

Frumkin's slow discharge theory — had been first proposed in 1933 [i] for taking into account the role of reaction layer structure in electrode kinetics. The theory is based on the potential dependence of the \rightarrow activation energy ΔG^\ddagger

$$\Delta G^\ddagger = \alpha F(\eta - \psi_1) + z_0 F \psi_1,$$

where η is the \rightarrow overvoltage (see \rightarrow potential, subentry \rightarrow overpotential), z_0 is the charge of the reacting species, and ψ_1 (named originally psi-prime potential) has a meaning of potential in the point of reactant location. By these means the slow discharge theory considers two basic effects, the potential drop in the reaction plane and the difference in reactant concentration in the bulk and in the reaction plane. The generalized version of the theory takes into account the energies of specific adsorption of the reactants and products as well. The slow discharge theory was able to explain the dependence of the reaction rate on the nature of electrode material, solution composition, and concentration. The detailed experimental tests covered the data on cathodic \rightarrow hydrogen evolution (mostly at mercury-like metals) [ii], and later the data on the electroreduction of anions on negatively charged electrodes [iii, iv] (see also \rightarrow peroxodisulfate). The latter group of model systems provided a possibility to check purely electrostatic effects in the absence of specific adsorption. The important and widely accepted [v, vi] application of the slow discharge theory is the \rightarrow Frumkin correction providing a possibility to study the elementary act of electron transfer in the framework of advanced theoretical models (see \rightarrow electron transfer, \rightarrow Marcus theory).

The classical version of Frumkin correction includes the initial procedure of z_0 determination [iii] from the dependence of current density on the supporting electrolyte concentration at constant electrode charge.

Refs.: [i] Frumkin A (1933) *Z phys Chem A* 164:121; [ii] Frumkin AN (1961) *Hydrogen overvoltage and adsorption phenomena, part 1, mercury*. In: Delahay P (ed) *Advances in electrochemistry and electrochemical engineering*, vol. 1. Interscience, New York; [iii] Frumkin AN, Petrii OA, Nikolaeva-Fedorovich NV (1963) *Electrochim Acta* 8:177; [iv] Frumkin AN, Nikolaeva-Fedorovich NV, Berezina NP, Keis KhE (1975) *J Electroanal Chem* 58:189; [v] Fawcett WR (1998) *Double layer effects in the electrode kinetics of electron and ion transfer reactions*. In: Lipkowsky J, Ross PN (eds) *Electrocatalysis*. Wiley-VCH, New York, p 323

GT, OP

FTO — Usual acronym for “fluorine-doped tin oxide”. Tin oxide is a \rightarrow semiconductor transparent to light in the visible range of the spectrum and fluorine doping is

used to reduce its electrical resistance. It is used, for example, as transparent electrode in photoelectrochemical experiments and as substrate for electrochemical preparation of optoelectronic devices.

Refs.: [i] Hartnagel HL, Dawar AL, Jain AK, Jagadish C (1995) *IOP. Bristol Philadelphia*; [ii] Chopra KL, Major S, Pandya DK (1983) *Thin Solid Films 102:1*; [iii] Rakhshani AE, Makdisi Y, Ramazaniyan HA (1998) *J Appl Phys 83:1049*

IH

Fuel cells — are electrochemical devices that convert the chemical energy of a reaction directly into electrical energy. In contrast to → *batteries* the fuel and the oxidant are continuously fed to the → *anode* and to the → *cathode*, respectively. The most attracting feature of fuel cells is a high efficiency. The theoretical efficiency exceeds 80% for hydrogen or methanol fuels at typical operation temperatures, i.e., 30 °C–100 °C. The practical conversion efficiency currently ranges between 35 and 70%, whereas the efficiency of heat engines is usually below 30% (with a maximum of 50%) [i]. The first fuel cells date back to → *Schönbein* and → *Grove* (1839) who proposed the first hydrogen-oxygen fuel cells. There are many classifications of fuel cells; the most basic one is – according to the operation temperatures – into low-temperature (operated at temperatures below 500 °C) and high temperature fuel cell (operation temperature usually between 500 and 1000 °C). Low-temperature fuel cells are → *alkaline fuel cells*, → *biofuel cells*, → *direct methanol fuel cell (DMFC)*, → *phosphoric acid fuel cell (PAFC)* and → *polymer electrolyte membrane fuel cells PEMFC*. Typical high-temperature fuel cells are → *molten carbonate fuel cells (MCFC)* and → *solid oxide fuel cells (SOFC)* [i–iii].

Refs.: [i] Vielstich W, Lamm A, Gasteiger HA (eds) (2003) *Handbook of fuel cells, fundamentals, technology and applications*. Wiley, Chichester; [ii] Kordesch K, Simander G (1996) *Fuel cells and their applications*. VCH, Weinheim; [iii] US Department of Energy (ed) (2004) *Fuel cell handbook*, 7th edn. EG&G Technical Services

US

Fugacity — The → *chemical potential* of an ideal single-component gas can be written in the form $\mu = \mu^0 + RT \ln p$, where p is the pressure. Particularly at higher pressures, gases show very substantial deviations from ideality, but it is often desirable to retain the functional form of the expression for chemical potential, and the fugacity, f , of a gas is defined by the expression $\mu = \mu^0 + RT \ln f$, where $f/p \rightarrow 1$ as $p \rightarrow 0$, since at low pressure all gases obey the ideal gas law. In principle, the value of μ^0 defined by the fugacity equation is not the same as that

in the ideal case: it is the molar free energy at unit fugacity. However, for many gases remote from the critical point deviations from ideality are only seen at pressure much higher than one atmosphere, and the difference in standard states is small. The calculation of fugacity is straightforward provided the equation of state of the gas is known, since we have from the definition of G for a single-component system $\left(\frac{\partial \mu}{\partial p}\right)_T = V = \left(\frac{RT \partial \ln f}{\partial p}\right)_T$,

whence $\ln\left(\frac{f}{p}\right) = \int_0^p \left(\frac{V'}{RT} - p'\right) dp'$. If the equation of state takes the simple form $p(V - B) = RT$, then we can carry out the integration at once to give $\ln\left(\frac{f}{p}\right) = \frac{Bp}{RT}$.

As in the case of activities, the fugacities of the two components of a mixture of gases are not independent; from the Gibbs–Duhem equation: $x_A d \ln f_A + x_B d \ln f_B = 0$.

Ref.: [i] Denbigh KG (1987) *Principles of chemical equilibrium*, 4th edn. Cambridge University Press, Cambridge

AH

Full-width-half-maximum (fwhm) → *half-peak-width*

Fullerenes — are a family of → *carbon* allotropes consisting of fused five- and six-membered rings forming spherical or elongated closed-cage structures [i]. When the cages encapsulate atoms or small molecules, the compounds are called endohedral fullerenes [ii]. The most common fullerene, C_{60} , contains 60 carbon atoms located at the vertices of a truncated icosahedron, a spherical polygon consisting of 12 pentagons and 20 hexagons [i]. The structure formed is identical to that of a soccer ball. The most commonly available fullerenes, normally obtained by purification of the soot produced by the Krätschmer–Huffman method, are C_{60} , C_{70} , C_{76} , C_{78} , and C_{84} [iii]. All carbons in fullerenes are sp^2 hybridized, which results in alternating single and double bonds. In contrast with flat graphitic systems, the curvature imposed by the presence of pentagons results in pyramidalization of the sp^2 carbons. This feature provides fullerenes with the ability to easily undergo addition reactions at the double bond junction between two six-membered rings. Consequently, a very large number of derivatives can be prepared by functionalizing the fullerene surface [iv]. Generally, all fullerenes of 60 or more carbon atoms contain 12 pentagons and obey the isolated pentagon rule (IPR). The rule states that all stable fullerenes have every pentagon surrounded by 5 hexagons [v]. This rule cannot be satisfied in molecules with fewer than 60 carbons, and it has also been violated by a family of C_{68} endohedral compounds [vi, vii].

Due to their high electron affinity fullerenes and their derivatives are easily reduced. However, their oxidation is somewhat difficult due to their higher ionization energy [viii]. The closed-shell molecular orbital (MO) configuration of C_{60} , for example, exhibits 30 molecular orbitals with 60 π -electrons, which fully occupy the highest occupied molecular orbital (HOMO). The energetically accessible LUMO (lowest unoccupied molecular orbital) is triply degenerate, resulting in relatively high affinity for up to six electrons in solution [ix]. On the voltammetric time scale, C_{60}^- through C_{60}^{6-} appear to be chemically stable, while only C_{60}^- through C_{60}^{4-} are stable under coulometric conditions.

C_{60} and its derivatives are also easily excited by low-energy light [x]. Thus, a rational combination of electronic properties with chemical reactivity and/or photoactivity has resulted in the preparation of numerous fullerene-derived materials, including low temperature superconducting salts [xi], radical scavengers [xii], materials for \rightarrow photovoltaic devices and \rightarrow conducting polymers [xiii].

Refs.: [i] Kroto HW, Heath JR, O'Brien SC, Curl RF, Smalley RE (1985) *Nature* 318:162; [ii] Guha S, Nakamoto K (2005) *Coord Chem Rev* 249:1111; [iii] Diederich F, Whetten RL (1992) *Acc Chem Res* 25:119, [iv] Hirsch A (1993) *Angew Chem Int Ed Engl* 32:1138; [v] Kroto HW (1987) *Nature (London)* 329:529; [vi] Fowler PW, Manolopoulos DE (1995) *An atlas of fullerenes*. Clarendon, Oxford; [vii] Stevenson S, Fowler PW, Heine T, Duchamp JC, Rice G, Glass T, Harich K, Hajdu E, Bible R, Dorn HC (2000) *Nature (London)* 408:427; [viii] Echegoyen LE, Herranz MA, Echegoyen L (2006) *Carbon, fullerenes*. In: Bard AJ, Stratmann M, Scholz F, Pickett CJ (eds) *Inorganic Electrochemistry. Encyclopedia of electrochemistry, vol. 7*. Wiley-VCH, Weinheim, pp 143–201; [ix] Xie Q, Perez-Cordero E, Echegoyen L (1992) *J Am Chem Soc* 114:3978; [x] Guldi DM, Prato M (2000) *Acc Chem Res* 33:695; [xi] Haddon RC (1992) *Acc Chem Res* 25:127; [xii] Nakamura E, Isobe H (2003) *Acc Chem Res* 36:807; [xiii] Wudl F (2002) *J Mater Chem* 12:1959

LEE, LE

Function generator — A function generator is an electronic device which generates a desired potential wave form (e.g., DC bias, steps, triangular, square, sinusoidal, and any desired combination thereof). Modern function generators are often interfaced with a computer which allows for a choice of user-selected and/or user-defined functions or combinations of functions. In electrochemical applications the function generator will provide the input for a \rightarrow potentiostat or

\rightarrow galvanostat. In many cases the function generator and potentiostat (and/or galvanostat) are combined and both are computer controlled.

SWF

Furman, Nathaniel Howell



(With permission of the Princeton University Library, Princeton University Archives, Department of Rare Books and Special Collections.)

(June 22, 1892, Lawrenceville, NJ, USA – Aug. 2, 1965, Burlington, VT, USA) [i, ii]. N. Howell Furman attended the Lawrenceville School where he was the leading scholar of the Class of 1909. He did his undergraduate degree at Princeton University graduating Phi Beta Kappa in 1913 and continued on there to earn his Ph.D., in 1917. He served in World War I as a private in the Chemical Warfare Service. From 1917–1919 he was an instructor in analytical chemistry at Stanford University and then returned to Princeton in 1919 as an Assistant Professor. During World War II he carried out research sponsored by the Office of Scientific Research and Development, participating in the Manhattan project and focusing on the analytical separation of uranium. He authored several books: “Elements of Quantitative Analysis” (with H.H. Willard and E.K. Bacon and a later edition with Willard and C.E. Bricker); “Potentiometric Titrations” (with \rightarrow Kolthoff). He also translated two of Kolthoff’s texts into English from the original German. Furman was also the editor in chief of “Scott’s Standard Methods of Chemical Analysis”. In 1948 he became the first recipient of the Fisher Award in Analytical Chemistry; in 1951 he became president of the American Chemical Society; in 1953 he was the recipient of the Palladium Medal of the Electrochemical Society – his successful application of electrochemical principles to the development of new methods and techniques of chemical analysis were specifically noted. From 1951–1954 he served as chairman of Princeton’s Chemistry Department. Among his students were \rightarrow Adams RN,

→ Reilley CN, and W.D. Cooke [iii]. Furman was the quintessential gentleman and scholar. He was revered as a teacher: his style was low-key and his lectures routinely described the latest advances in the field. He cared equally deeply about the students and the subject matter.

Refs.: [i] Who was who in America, volume IV. Marquis-Who's Who, Chicago, p 339; [ii] Thomas Spiro and Stephanie Greene, Department of Chemistry, Princeton University, additional biographical information, private communication; [iii] Furman NH, Cooke WD, Reilley CN (1951) Anal Chem 23:945

SWF

G

Gaiffe cell

(a) This was a variation of the → *Leclanché cell*.

(b) This was a variant of the → *Daniell cell*.

See also → *zinc*, → Zn^{2+}/Zn electrodes, → $Zn^{2+}/Zn(Hg)$ electrodes, → *zinc-air batteries (cell)*.

Ref.: [i] Hauck WP (1883) *Die Galvanischen Batterien, Accumulatoren und Thermoäulen*, 2nd edn. Hartleben's Verlag Wien

Galvani, Luigi



(Courtesy of IEEE Virtual Museum, Rutgers University History Center, USA)

(Sep. 9, 1737, Bologna, Papal state, now Italy – Dec. 4, 1798, Bologna, Cisalpin Republic, now Italy). Galvani was a physician and physicist who investigated the nature of electrical effects in animal tissue [i, ii]. In his early studies, Galvani worked in comparative anatomy and physiology, including a study of the kidneys of birds and of their sense of hearing. His interest in electrical phenomena was initiated with the accidental observation (1780) of the twitching of the legs of a dissected frog when a bared crural nerve was touched with the steel scalpel, while sparks were passing from an electric machine nearby. This was the beginning of his extensive studies of electrical effects produced in animal tissues [iii, iv]. → *Electrochemistry*, and particularly, → *bioelectrochemistry* were started from Galvani's experiments. Galvani provided the major stimulus for Volta to discover a source of constant current electricity (→ *Volta pile*). Galvani's name survives in the → *Galvanic cell*, the → *galvanometer*, → *galvanism*, etc.

Refs.: [i] Galvani L, *Encyclopædia Britannica*; [ii] Kipnis N (1987) *Ann Sci* 44:107; [iii] Galvani L (1791) *De Viribus Electricitatis in Motu Musculari Commentarius*. (Commentary on the effect of electricity on muscular motion, essay) *Accademia delle Scienze, Bologna*; [iv] Galvani L

(1794) *Dell'Uso e dell'Attività dell'Arco Conduttore nella Contrazione dei Muscoli*. (On the use and activity of the conductive arch in the contraction of muscles, essay) *Accademia delle Scienze, Bologna*

EK

Galvanic — Following the epochal experiments of → *Galvani*, in which electric discharges were shown to activate the dissected muscles of a frog [i], the word “galvanic” was adopted by a small group of scientists to describe this particular effect. However, shortly thereafter, → *Volta* announced the invention of his eponymous pile (which consisted of alternating disks of zinc and copper separated by brine-soaked cloth), and with this new source of electricity it became possible to carry out galvanic experiments for longer periods, and on a much wider range of materials, than previously. As a result, the word “galvanic” rapidly spread into much wider usage. Today, the word “galvanic” has entered most languages in the world, and remains in regular use in three principal areas of science: (a) to describe electricity generated spontaneously from a voltaic pile (→ *galvanic cell*), (b) to describe phenomena occurring at the junction of two dissimilar metals (galvanic contact, galvanic corrosion), and (c) to describe phenomena occurring at the interface between an electrode and living cells (galvanic skin response).

FS

Refs.: [i] Galvani AL (1791) *De viribus electricitatis in motu musculari*, pub. *Accademia delle Scienze, Bologna*; [ii] Volta A (1800) *Philos Trans R Soc London* 2:403

SF

Galvanic cell (or galvanic element) — A galvanic cell is an → *electrochemical cell* in which reactions occur spontaneously at the → *electrodes* when they are connected externally by a conductor. In these cells chemical energy can be converted into electrical energy [i, ii]. The galvanic cell consists of two electrodes, i.e., electron conductors (→ *metal*, → *carbon*, → *semiconductor* etc.) in contact with one or more ionic conductors (which may be → *electrolyte* solutions, → *ionic liquids*, electrolyte melts, or → *solid electrolytes*).

The electrodes may be separated by a → *salt bridge* or a glass frit, or an → *ion-permeable (exchange) membrane* or a porous inert → *diaphragm*, or – in the case of → *concentration cells* without transference even with a metal in contact with its poorly soluble salts. The galvanic cell is represented by a → *cell diagram*. In the galvanic cell an → *electrochemical cell reaction* occurs. The relationship between the molar → *Gibbs (free) energy* change (ΔG) of the cell reaction and the **potential of the cell reaction**

(E_{cell}) is as follows:

$$E_{\text{cell}} = -\frac{\Delta G}{nF}, \quad (1)$$

where n is the \rightarrow *charge number* of the cell reaction and F is the \rightarrow *Faraday constant*.

Galvanic cells as power (current) sources include primary (non-rechargeable) cells, secondary (rechargeable) cells (\rightarrow *batteries*), and \rightarrow *fuel cells*.

The \rightarrow *concentration cells* are used only for determination of \rightarrow *transport (transference) numbers*, \rightarrow *activity*, and \rightarrow *activity coefficients* of electrolytes and other quantities. Their practical application is limited by the \rightarrow *self-discharge* due to the spontaneous diffusion process. In concentration cells no chemical reactions occur, a physical process (the equalization of activities by diffusion) causes the potential difference and supplies the energy.

Galvanic cells can also be used as sensors since a supply of a compound that can be oxidized or reduced, can induce current flow. There are several gas analyzers working by this principle, a typical example is the \rightarrow *Hersch cell* for monitoring oxygen concentration.

Refs.: [i] Cohen ER, Cvitas T, Frey JG et al. (eds) (2006) *IUPAC quantities, units and symbols in physical chemistry*, p 82; [ii] Bard AJ, Faulkner LR (2001) *Electrochemical methods*, 2nd edn. Wiley, New York, pp 11–18

GI

Galvanic element \rightarrow *galvanic cell*

Galvani potential difference \rightarrow *potential*, subentry \rightarrow *galvanic potential difference*

Galvanic process — Electrochemical process occurring **spontaneously** in a cell at two electrodes connected externally by a conductor. The \rightarrow *anode* due to the oxidation of the substrate is charged negatively, the \rightarrow *cathode* as a donor of electrons is charged during the reduction positively. The electrons flow externally from the anode to the cathode and this \rightarrow *faradaic current* can be used for a work. These systems represent a change of chemical to electrical energy and are utilized as source of voltage in batteries, rechargeable accumulators, or in fuel cells.

JL

Galvanism \rightarrow *Galvani's* investigation on “animal electricity” inspired \rightarrow *Volta's* experiments which eventually led to the birth of electrochemistry, and the production of electric current. The most spectacular part of Galvani's experiment was the contraction of frog legs which

has been repeated by others afterwards with other muscle preparations, and it became a part of many shows in the 19th century. It seemed as if they could restore the muscle preparation to life. It was called galvanism, which is preserved in today's language in the expression: galvanize, i.e., a person may be galvanized into action (to rouse into doing something) [i–ii]. The expression galvanism has been used in physics for electrical phenomena originated by contact [iii]. The definition of galvanism in the present English language [i–ii] is as follows: “Electricity produced by chemical action, especially that of acids on metals; the branch of science dealing with this, its application for medical purposes.” “To apply galvanism to, especially, to stimulate muscular action by galvanism; to plate with gold or other metal by galvanism.” The flow of electricity is often called “galvanic electricity”, and we speak of \rightarrow *galvanic cells*. Iron protected by zinc against corrosion is called “galvanized iron”. For the measurement of current we use a \rightarrow *galvanometer*. Reproduction of objects by “galvanization” is called \rightarrow *galvanoplastics*. The terms galvanocoating and galvanodeposition are sometimes also used instead of electrocoating (\rightarrow *electrodeposition*). Although we still honor the memory of Galvani in many other expressions in electrochemistry beside those mentioned above (e.g., \rightarrow *Galvani potential difference*, \rightarrow *galvanostatic*, \rightarrow *galvanostat*), the term “galvanism” is not used in electrochemical science nowadays.

Refs.: [i] Hornby AS, Gatenby EV, Wakefield H (1970) *The advanced learner's dictionary of current English*. Oxford University Press, London; [ii] Hayward AL, Sparkes JJ (1988) *The concise English dictionary*. New Orchard Editions, Poole, Dorset, p 473; [iii] Larousse Dictionnaire (1991) *Librairie Larousse*, Paris

GI

Galvanize — (1) To stimulate living cells by means of an electric current. (2) To electroplate a metal surface with a dissimilar metal; in particular, to electroplate iron with zinc. In the latter case, the term is also commonly misapplied to iron that has been dip-coated with zinc. (3) Figuratively, to restore something to life from a dormant state.

SF

Galvanocoating \rightarrow *galvanism*

Galvanodeposition \rightarrow *galvanism*

Galvanodynamic measurements — also referred to as “programmed current \rightarrow *chronopotentiometry*” [i], are the controlled current analogues of potential sweep

methods (\rightarrow *cyclic voltammetry*). They are based on the measurement of the potential as a function of a swept (or stepped) current using a \rightarrow *galvanostat*. Galvanodynamic methods are less commonly used than potentiodynamic methods. Their domain is the study of the polarization behavior of electrodes in \rightarrow *corrosion* and \rightarrow *fuel cell* research.

See also: \rightarrow *galvanostatic techniques*, \rightarrow *constant-current techniques*.

Ref.: [i] Bard AJ, Faulkner LR (2001) *Electrochemical methods*, 2nd edn. Wiley, Chichester

US

Bericht über die Entwicklung der Galvanoplastik. Bulletin de la Classe Physico-Mathématique de l'Académie Impériale des Sciences de Saint-Petersbourg 1. Sp 65–71

SF

Galvanometer \rightarrow *ammeter*

Galvanometry — Obsolete term for the art and process of measuring the strength of electrical \rightarrow *current*.

Ref.: [i] Michels W (ed) (1956) *The international dictionary of physics and electronics*. Van Nostrand, Princeton

FS

Galvanoglyphy — An electrotype process in which a copy of an engraved plate is produced with a raised surface, suitable for letter-press printing. The term originated in the Victorian era, and is synonymous with glyphography, electrotint, cerography, etc. In the first stage of the process, an artist incised a design into the surface of a wax-coated plate by means of a hand tool. After dusting with graphite, the remaining wax was then electroplated with copper, filling the incised lines and forming the master plate for printing. After the invention of the \rightarrow *Daniell* cell in 1836, which provided a stable electrical current for several hours, galvanoglyphy based on thick copper plating became technologically feasible, and a number of practical processes soon emerged. These provided an inexpensive means of making durable printing plates for mass production. Early success was achieved by CJ Jordan [i], Thomas Spencer and John Wilson [ii], Sidney Edwards Morse (1794–1871) [iii], and Moritz Hermann Jacobi (1801–1874) [iv]. However, many others developed similar processes around the same time, but withheld the details as trade secrets.

Refs.: [i] Jordan CJ (1839) *Engraving by galvanism*. *Mechanics Magazine*; [ii] Spencer T, Wilson J (1849) *Certain improvements in the process of engraving upon metals by means of voltaic electricity*. British Patent No 8656, 7th October 1840; [iii] Morse SE (1843) *Cerographic atlas*. SE Morse & S Breese, New York; [iv] Jacobi MH (1843)

Galvanoplastics (electrotyping) — This is a process of producing duplicates of reliefs, sculptures, letterpress, etc., usually by plating a thin copper or other metal layer onto a mold, e.g., from wax with a layer of graphite on it to make it conductive. When that metal layer is deposited thick enough to remove it from the mold, the backside can be backed with metal. Galvanoplastics was invented by \rightarrow *Jacobi* in 1838. The term galvanoplastics is also used when items like leaves, flowers, small animals, shoes, etc., are covered by a galvanic plating of a metal layer, be it for the case of preservation, or for the production of art. See also \rightarrow *electroforming*, \rightarrow *electroplating*.

FS

Galvanoscope — Early instrument to indicate currents and for obtaining a rough estimate of its magnitude. The simplest galvanoscope had a single metal coil and a magnetic needle that shows a deflection when a current passes the wire (\rightarrow *Ørsted*). Later instruments with multiple metal coils were called multiplier or multiplier (\rightarrow *Poggendorff*, \rightarrow *Schweigger*).

Ref.: [i] <http://physics.kenyon.edu/EarlyApparatus/>

FS

Galvanostat — A galvanostat is a constant current device, an amplifier which sends a constant current

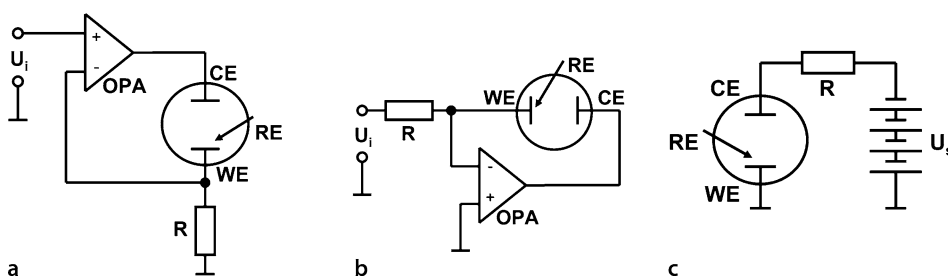

Galvanostat — Figure

through an electrochemical cell via → *counter electrode* (CE) and → *working electrode* (WE). The WE is normally connected to ground potential and the potential drop at the WE is often monitored by an optional → *reference electrode*. Two simple circuits based on → *operational amplifiers* are presented in Fig. (a) and (b). The cell current is given by $I = -U_i/R$ in both cases. Disadvantageous in (a) is that the WE is not at ground potential, in (b) that the source U_i has to deliver the total current I .

If the potential drop at the cell U_{cell} is large, the maximum current I_{max} can be limited by the maximum output voltage U_{max} of the amplifier as U_{max} must be larger than $U_{\text{cell}} + I \cdot R$. Typical laboratory devices deliver currents in the range from ±50 mA to ±1 A at output voltages from ±10 to ±100 V.

If a stabilized power supply with large output voltage U_S (e.g. > 100 V) is available, the simple circuit of Fig. (c) can be used, where the current is given by $I = \frac{U_S - U_{\text{cell}}}{R}$. If $U_{\text{cell}} \ll U_S$ then $I \cong U_S/R$. This concept was common before 1960.

Ref.: [i] Bard AJ, Faulkner LR (2001) *Electrochemical methods*, 2nd edn. Wiley, New York

MML

Galvanostatic intermittent titration technique (GITT)

— Technique applied to measure the chemical → *diffusion coefficient* of the intercalating species within insertion-host electrode materials through the electrochemical cell, followed by the voltage response after a short constant current pulse that is recorded as voltage-time curve [i]. The theory of this technique is based on the equation of $D = \frac{4}{\pi t} \left(\frac{m V_M}{MS} \right)^2 \left(\frac{\Delta E_s}{\Delta E_t} \right)^2$, where D is the chemical diffusion coefficient; t is the constant current pulse time; m , V_M , and M are the mass, the molar volume, and the molar mass of insertion-host electrode material, respectively; S is the area of the electrode-electrolyte interface; ΔE_s is the change of the steady-state voltage during a single-step GITT experiment; ΔE_t is the total change of cell voltage during the current pulse time t of a single-step GITT experiment (the IR drop excluded).

Ref.: [i] Weppner W, Huggins RA (1977) *J Electrochem Soc* 124:1569

XCT

Galvanostatic techniques — In galvanostatic techniques the → *current* is controlled and the → *potential* is the dependent variable. The current is usually held constant or stepped by programming, while the potential is measured as a function of time. The experiment is carried out by applying a → *galvanostat*. See also → *constant current techniques*, → *Sand equation* → *chronopotentiometry*, → *coulometry*, → *coulometric techniques*, → *charging current*.

Ref.: [i] Bard AJ, Faulkner LR (2001) *Electrochemical methods*, 2nd edn. Wiley, pp 305–330

GI

Galvanotropism — In analogy to other tropisms [i], the orientation of a living organism in an → *electric field*. The term was introduced by Herrmann in 1885 [ii]. → *Loeb* published a number of studies on galvanotropism. The physiological mechanism of galvanotropism of eukaryotic cells has been elucidated recently [iii, iv]. Galvanotropism should **not** be confused with the passive movement of cells in electric fields, as it is observed, e.g., in → *dielectrophoresis*, → *travelling-wave dielectrophoresis*, → *electrorotation*, and → *Quincke rotation*.

Refs.: [i] Mast SO (1915) *Arch Entwicklungsmech Organismen (Dev Genes Evol)* 41:251; [ii] Hermann L (1885) *Pflügers Arch* 37:457; [iii] McCaig CD (1989) *Biol Bull* 176:136; [iv] Brand A, Shanks S, Duncan VMS, Yang M, Mackenzie K, Gow NAR (2007) *Curr Biol* 17:347

FS

Gas-activated battery → *reserve battery*

Gas constant (molar) — Symbol: R , SI unit: $\text{J K}^{-1} \text{mol}^{-1}$. Definition: $R = N_A k_B$; i.e., the Avogadro constant (N_A) is multiplied by the → *Boltzmann constant* (k_B).

Its best value:

8.314510(70) $\text{J K}^{-1} \text{mol}^{-1}$ (1993) [i]

8.314472(15) $\text{J K}^{-1} \text{mol}^{-1}$ (2006) [ii]

It is the constant that appears in the universal gas equation, however, R is widely used in thermodynamic and electrochemical relationships, e.g., in the → *Nernst equation*.

Refs.: [i] Mills I, Cvitas T, Homann K, Kallay N, Kuchitsu K (eds) (1993) *IUPAC quantities, units and symbols in physical chemistry*. Blackwell, Oxford, p 39, 89; [ii] Cohen ER, Cvitas T, Frey JG et al. (eds) (2007) *IUPAC quantities, units and symbols in physical chemistry*, 3rd edn. RSC Publishing, Cambridge, p 111

GI

Gas diffusion electrode — (also: gas fed electrode) Electrode employed in → *fuel cells*, → *electrolysers*, and → *sensors*. The electrode is a porous body prepared in various ways from a variety of materials [i]. Hydrophilic electrodes are mostly made from metals (e.g., nickel). The material is finely dispersed (e.g., by the Raney process) and manufactured into a sheet or plate. Depending on the wetting properties and the pore size, large pores will be wetted and subsequently filled by the electrolyte solution (or molten electrolyte salt), fine pores are not filled

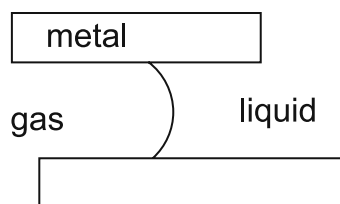

Gas diffusion electrode — Figure

but instead will allow access of the gas from the other side of the electrode. Inside the electrode a three-phase boundary electrode/solution/gas is established providing a large area where the various components and reactants can get into close contact.

Semihydrophobic electrodes are made from an active electrode material (\rightarrow *electrocatalyst*), a binder (dissolved polymer), and a hydrophobizing agent (e.g., dispersion of polytetrafluoroethylene PTFE). Upon thorough mixing a slurry is obtained, which is spread onto a material serving as mechanical carrier and in most cases also as current collector. After removal of the solvent a porous layer/sheet is obtained. Upon contact with an aqueous electrolyte solution various interactions are possible [ii]:

- In a hydrophilic system most of the inner surface is wetted with solution, the PTFE aggregates from gas channels providing gas supply.
- In a hydrophobic system catalyst agglomerates form channels which are wetted with the electrolyte solution, most of the internal surface is not wetted.
- In a homogeneous mix the local PTFE-content controls the wetting angle and consequently the local degree of wetting, a statistical distribution of dry pores is established.

The actual type of system depends on the PTFE-content and various other preparation and operation parameters.

Refs.: [i] Justi EW, Winsel AW (1962) *Kalte Verbrennung*. Steiner-Verlag, Wiesbaden; [ii] Pshenichnikov AG, Kryukov Yu, Burshtein RKh, Astakhov II, Surikov VV (1976) *Sov Electrochem* 12:1183

RH

Gas sensors

(a) **Gas sensors with liquid electrolytes** — Devices in which information on the concentration of a gaseous \rightarrow *analyte* is transformed into an analytically useful signal, and where \rightarrow *diffusion* and \rightarrow *migration* processes are taking place in liquid electrolyte

solutions [i, ii]. Amperometric and potentiometric sensors are the two major sensor classes [i, ii]. Potentiodynamic gas sensors are less frequently employed because of the more complicated potential-time programs, and more complicated data analysis [ii, iii]. The sensors usually work at room temperature and share features such as a gas entry chamber or membrane, the use of at least two electrodes, and an ion-conducting electrolyte [ii].

- Amperometric gas sensors are \rightarrow *electrochemical cells* that produce a \rightarrow *current* signal directly related to the concentration of the \rightarrow *analyte* by \rightarrow *Faraday's law* and the laws of \rightarrow *mass transport*. The schematic structure of an amperometric gas sensor is shown in Fig. 1. The earliest example of this kind of sensor is the \rightarrow *Clark sensor* for oxygen. Since that time, many different geometries, membranes, and electrodes have been proposed for the quantification of a broad range of analytes, such as CO, nitrogen oxides, H₂S, O₂, hydrazine, and other vapors.

The response of an amperometric gas sensor is associated with the diffusion of the \rightarrow *analyte* to the \rightarrow *working electrode*, the actual electrochemical reaction, and the purging of electrochemical products from the \rightarrow *working electrode* surface. It is operated in a region where \rightarrow *mass transport* is limiting and therefore ideally has a linear response on the \rightarrow *analyte* concentration. Amperometric gas sensors with liquid electrolytes have some advantage over many other kinds of sensors because they combine relatively high sensitivity, selectivity, suitable \rightarrow *response times* (i.e. < 30 s to achieve 90% of the \rightarrow *limiting current*) and low power consumption. However, they have a larger size and higher

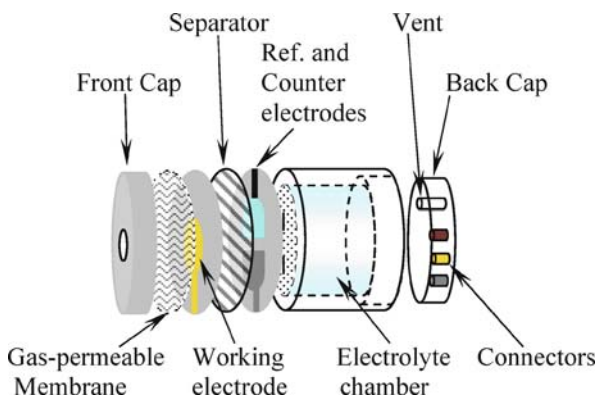

Gas sensors — (a) Gas sensors with liquid electrolytes — Figure 1. Scheme of an amperometric gas sensor

cost than devices with solid electrolytes, as well as time-related problems such as leakage, → *corrosion*, and evaporation or contamination of the → *electrolyte* [ii].

- Potentiometric gas sensors with liquid electrolyte are based on measuring the → *cell voltage* as a function of the concentration of a chemical species in the sample. In the broadest definition, such measurement can be performed at any cell → *current*; however, the majority of potentiometric sensors measure the potential at near-zero current. Their design is frequently similar to the → *Severinghaus electrode*, in which a flat-bottom → *pH* or → *ion-selective electrode* is placed behind and very close to a gas-permeable membrane (Fig. 2). Thus, great selectivity is achieved over many potentially interfering gaseous species, since they must cross the gas-permeable membrane, react with the → *electrolyte* of solution (B), and its resulting → *ionic product* be recognized by the → *ion-selective electrode*. Usually, this class of sensor has a lower cost and simpler associated electronics than amperometric gas sensors with liquid electrolytes. However, the → *response times* are quite slow and have to be calibrated periodically [iv]. See also → *ammonia sensor*, → *carbon dioxide sensor*.
- Potentiodynamic gas sensors have a schematic structure that is practically equal to that of amperometric gas sensors. They are → *electrochemical cells* that measure a → *current* signal directly related to the concentration of the analyte, but are not necessarily operated in a region where → *mass transport* is limiting. They are typically employed to detect less reactive species such as benzene and halogenated hydrocarbons that require a previous accumulation step at a suitable → *adsorption* potential to be then reduced or oxidized according to a given potential scan [iii]. The adsorption time can be automat-

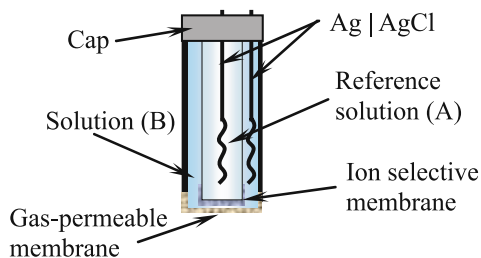

Gas sensors — (a) Gas sensors with liquid electrolytes — Figure 2. Scheme of a potentiometric gas sensor

ically adjusted to a specific application in order to increase the range of analysis. Furthermore, the selectivity and sensitivity of these sensors can be optimized by changing the parameters of a potential-time program. At the moment, however, they are mainly prototype devices that require further optimization to increase their lifetime and automation [iii].

- → *galvanic cells* can also be used as gas sensors. See → *Hersch cell*.

Refs.: [i] Stetter JR, Penrose WR, Yao S (2003) *J Electrochem Soc* 150:S11; [ii] Cao Z, Buttner WJ, Stetter JR (1992) *Electroanalysis* 4:253; [iii] Baltuschat H, Kamphausen I, Oelgeklaus R, Rose J, Wahlkamp M (1997) *Anal Chem* 69:743; [iv] Mowery MD, Hutchins RS, Molina P, Alajarín M, Vidal A, Bachas LG (1999) *Anal Chem* 71:201 [ii] Janata J, Bezegeh A (1988) *Anal Chem* 60:62R

FG

(b) Gas sensors with solid electrolytes — Electrochemical cells using → *solid electrolyte* are widely used as gas sensors. As a solid electrolyte gas-tight sintered ceramics in form of tubes, discs, planar substrates, or thick films consisting of → *stabilized zirconia* (e.g., YSZ means the most common solid electrolyte yttria-stabilized zirconia) are utilized. With increasing temperature the electrical → (*ionic*) *conductivity* increases exponentially. Solid electrolyte sensors are suited to measure gas components in three kinds of gas phases:

- gas mixtures that contain free oxygen beside inert gases, e.g., O₂, N₂ (potentiometric and → *amperometric sensors*)
- gas mixtures that are in chemical equilibrium, e.g., water gas (→ *potentiometric sensors*)
- gas mixtures of non-equilibrated gases, e.g., of hydrocarbons with oxygen or nitric oxides with oxygen (→ *mixed potential sensor* or non-Nernstian sensors)

Potentiometric sensors for free oxygen and equilibrium oxygen are very common in gas phases with established thermodynamical equilibria (e.g., $p(\text{H}_2\text{O})/p(\text{H}_2)$) or, generally, the ratio of partial pressures of burnt and non-burnt components). For that purpose highly porous platinum is used as an electrode material (Fig. 3, left). Such cells symbolized by

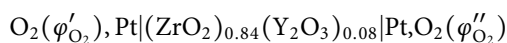

can be regarded as an oxygen concentration cell. They work depending on electrode material in a broad range

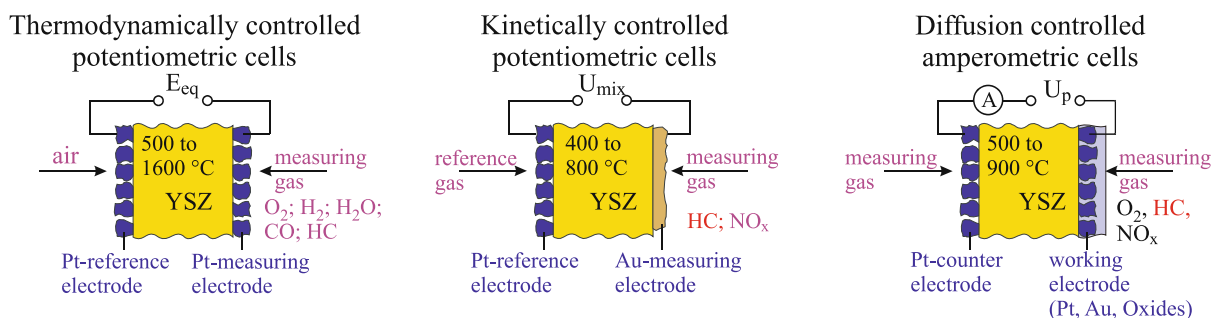

Gas sensors — (b) Gas sensors with solid electrolytes — Figure 3. Basic principles of gas sensors based on oxide ion-conducting solid electrolytes

of temperature (400 to 1600 °C) and oxygen partial pressure (10 bar to 10^{-20} bar). Using the \rightarrow Kröger-Vink notation for defects:

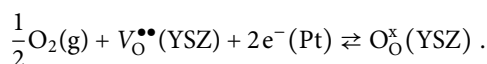

The cell reaction is the transfer of oxygen from one side to the other. (See also \rightarrow Lambda probe). In the case of an \rightarrow electrochemical equilibrium (subentry of \rightarrow equilibrium) the measured \rightarrow open circuit potential (subentry of \rightarrow potential) or \rightarrow equilibrium potential (subentry of \rightarrow potential) U_{eq} or E (emf) can be calculated by the \rightarrow Nernst equation:

$$E = -U_{\text{eq}} = \frac{RT}{4F} \ln \frac{p'_{\text{O}_2}}{p''_{\text{O}_2}}.$$

Therefore such sensors are called Nernstian sensors. As a reference air with defined humidity is used. In reducing gases that are in chemical equilibrium (e.g., H_2 , H_2O ; CO , CO_2 ; water gas) the oxygen partial pressure is determined by the mass law constant K_p and this in turn depends on the temperature. In the case of H_2 , H_2O -mixtures the cell voltage is obtained by insertion of a temperature function of $\log K_p$ into the Nernst equation

$$\log K_p = 2.947 - 13,008 [\text{K}] / T.$$

With pure oxygen as p''_{O_2} :

$$E(\text{H}_2, \text{H}_2\text{O})/\text{mV} = -0.0496 \frac{T}{[\text{K}]} \log \left[K_p \left(\frac{p_{\text{H}_2\text{O}}}{p_{\text{H}_2}} \right) \right]^2$$

$$E(\text{H}_2, \text{H}_2\text{O})/\text{mV} =$$

$$1290.6 - \left[0.2924 + 0.0992 \log \left(\frac{p_{\text{H}_2\text{O}}}{p_{\text{H}_2}} \right) \right] \frac{T}{[\text{K}]}.$$

Main field of application is the fast measuring of oxygen concentration in liquid metals and gases, such as flue gases of combustion in steam boilers, in glass and ceramic manufacturing industries [ii]. The lambda probes for the detection of the oxygen/fuel ratio are also oxygen concentration cells (Fig. 4). The signal of a lambda probe (black curve) is low in the case of an excess of oxygen (lean mixtures, left side, $\lambda > 1$) and high at an excess of fuel (rich mixtures, $\lambda < 1$, right side). Oxygen concentration cells can also be constructed with other solid electrolytes provided that the ionic \rightarrow transport number is one. But the \rightarrow response time of such sensors is much slower than that of sensors using oxide ion-conducting electrolyte.

The measuring of gas components like hydrocarbons (HC) or nitric oxides (NO_x) in non-equilibrated gas phases becomes more and more important. Depending on the electrode material, the gas components do not equilibrate on the measuring electrode at temperatures < 700 °C. Thus gas components, which are not thermodynamically stable, are electrochemically active. In HC and O_2 containing gas at least two electrode reactions can take place: the electrochemical reduction of oxygen and the electrochemical oxidation of hydrocarbons. The measured open-circuit voltage does not obey the \rightarrow Nernst equation. Therefore such electrode behavior is often referred to non-Nernstian electrodes (or mixed potential sensors) (Fig. 3, middle). According to the theory by Miura [iii] based on the \rightarrow Butler-Volmer equation the cell voltage mainly depends logarithmically on the concentrations (Fig. 4, blue curve). The mixed potential of such solid electrolyte electrodes is contrary to that of electrodes in aqueous solution very stable and reproducible [iv].

Especially composites consisting of gold and oxides like Ga_2O_3 and Nb_2O_5 perovskite-type mixed oxide (ABO_3) with Cr and Ga as B-cation are suited as

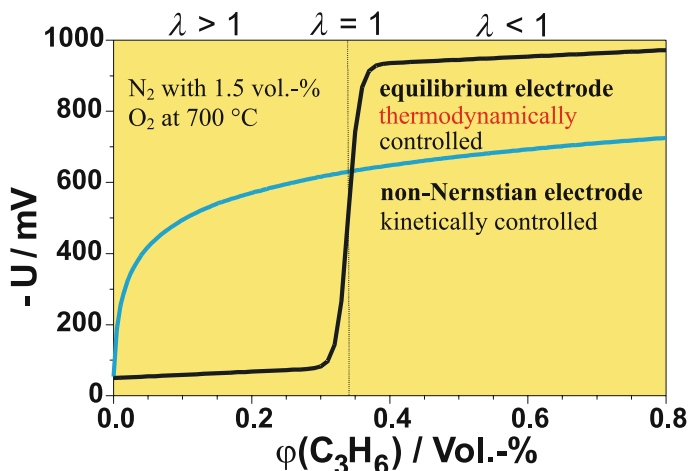

$$E = \frac{R \cdot T}{4F} \ln \frac{p(\text{O}_2)_{\text{eq}}}{p(\text{O}_2)_{\text{ref}}}$$

$$U_{\text{mix}} = U_0 - A \ln(\varphi_{\text{HC}})$$

Gas sensors — (b) Gas sensors with solid electrolytes — Figure 4. Voltage characteristics of an idealized hydrocarbon electrode vs. Pt-air reference electrode in propylene-containing mixtures

hydrocarbon-sensitive electrode material. Materials exhibiting a low catalytic activity for the combustion of hydrocarbons show a high sensitivity (several mV/ppm HC) [v]. A mixed potential sensor combines an oxygen electrode as a reference and a second electrode, which shows a low oxygen sensitivity but a high hydrocarbon-sensitivity. Both electrodes may be exposed to the analyte gas (Fig. 5). Alternatively, the sensor can operate with an oxygen electrode exposed to air as an external reference.

→ *amperometric sensors* work at a certain voltage in which the electrode reaction is determined by the gas transport (Fig. 3, right). The diffusion barrier consists of porous ceramic or a small hole. With the area A and the length L of the hole and the diffusion coefficient of

oxygen D_{O_2} the current measured is proportional to the oxygen partial pressure.

$$I_{\text{lim}} = -\frac{4FD_{\text{O}_2}A}{RTL} p_{\text{O}_2} \cdot$$

By means of amperometric sensors a simultaneous determination of oxygen and hydrocarbons or nitric oxides is possible. For such sensors tube [vi, vii] or planar [viii] designs were described. The current measured is proportional to the oxygen concentration and the concentration of hydrocarbons and nitric oxides, respectively.

Nernstian gas concentration cells operating in the temperature range 300–700 °C are also used for determination of CO_2 . Those cells consist of sintered gas-

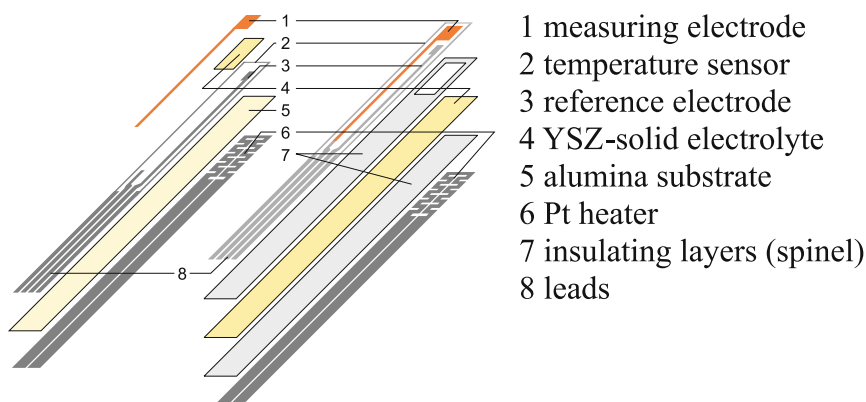

Gas sensors — (b) Gas sensors with solid electrolytes — Figure 5. Schematic drawing of the layer structure of a mixed potential sensor

tightly sodium carbonate (or mixtures of sodium and barium carbonates) covered on both side with gold layers which separate two gas chambers (Fig. 6, left).

According to the following equation the cell emf depends on both concentrations CO_2 and O_2 .

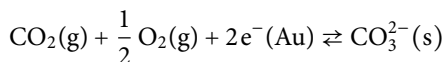

measuring electrode

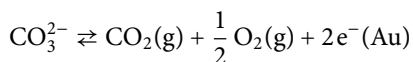

reference electrode

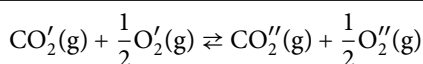

cell reaction .

The charge compensation occurs by migration of sodium ions from the side having a lower CO_2 and O_2 concentration to the other one with lower concentration. If a current flows sodium carbonate is formed on the side with higher gas concentration and disappeared on the other side. That behavior is different from oxygen concentration cells using stabilized zirconia. In the temperature range 450–700 °C CO_2 can be measured continuously from ppm to the percentage level over more than one year [ix].

Because pressed alkali carbonates are often hygroscopic and tend to sublimate a combination of alkali carbonates and a stable alkali ion conductor like \rightarrow Nasicon, \rightarrow β' -alumina or β'' -alumina as an electrolyte are used (Fig. 6, middle) [x]. The β -alumina can be formed as a thin layer on a α -alumina substrate [xi].

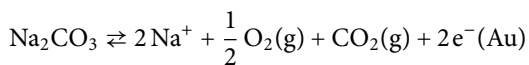

measuring electrode

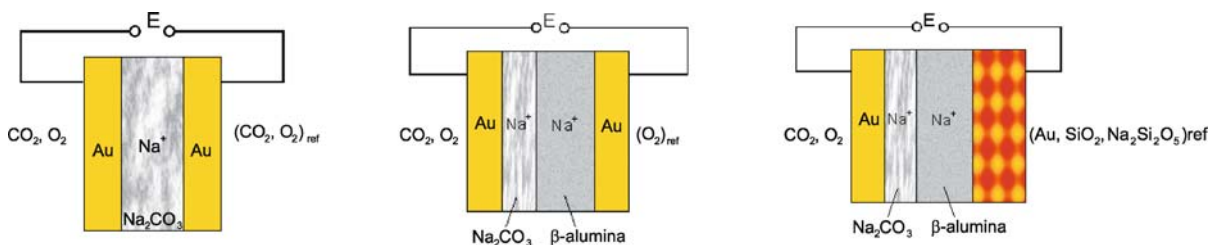
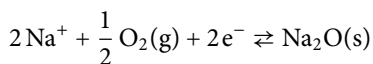

Gas sensors — (b) Gas sensors with solid electrolytes — Figure 6. Basic principle of CO₂ sensors

reference electrode

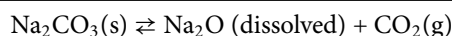

cell reaction .

On the measuring electrode CO_2 and O_2 are electrochemically transformed whereas on the reference side oxygen is reduced. The reference electrode potential can be established by fixing sodium oxide activity using $\text{Na}_x(\text{Hg})$ and Na_xCoO_2 respectively [xii]. Possible is also a gold or platinum layer covered by a glass. An elegant solution is to fix the O_2 by a solid thermodynamic system like SiO_2 , $\text{Na}_2\text{Si}_2\text{O}_5$ (Fig. 6, right) [xiii]. Then the reaction on the reference electrode is

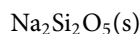
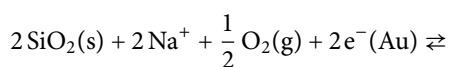

and hence the cell reaction

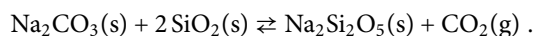

If the solid components are pure the cell emf depends only on the CO_2 partial pressure:

$$E = \text{const} + \frac{RT}{2F} \ln p_{\text{CO}_2} .$$

Instead of the system silica/silicate also other systems such as titania/titanate, zirconia/zirconate can be used as a reference system [xiv]. The response time of freshly fabricated thick-film sensors based on thin-film β -alumina is very short (about 15 ms at 650 °C). After several weeks of operating this time increases 10 times (150 ms) [xv]. Solid electrolyte CO_2 sensors using Ni/carbonate composite as measuring electrode are suited for measuring of CO_2 in equilibrated water gases [xiv]. Using semiconducting oxides and carbonates like ITO (indium tin oxide) Nasicon-based CO_2 sensors are able to measure at room temperature [xvi].

(c) Metal oxide gas sensors — (MOS, MOG, *semiconductive/resistive sensors*) consisting of SnO₂ or ZnO are used in the form of single crystals, thin layers, or sintered polycrystalline thick-films (Figs. 7, 8) as sensors for detection of combustibles and hazardous gases such as CO, hydrocarbons, NO₂. The basic principle is the change of the electrical (surface) conductivity due to the exchange of chemisorbed oxygen (O⁻) by reducing species (HCs). As a result, oxygen gives the electrons back to the surface of SnO₂ and the conductivity is increased. Those sensors also react on oxidizing gases such as NO₂ in opposite direction. The sensitivity S_i to the gas species i , different to the usual definition, is expressed by relative change of conductance $G = 1/R$.

$$S_i = \frac{G_i - G_{\text{air}}}{G_{\text{air}}} = \frac{R_{\text{air}} - R_i}{R_i} \cong \frac{G_i}{G_{\text{air}}}$$

MOS are very sensitive (detection limit a few ppm) but not selective. To improve the selectivity finely distributed catalysts (e.g., Pt, Pd [xvii]), admixtures with diverse metal oxide (MeO) additives (e.g., La₂O₃, CuO, ZnO, In₂O₃ [xviii–xx]), and ionic conductors (e.g., Nasion [xxi]) are added or doped-SnO₂ layers with aliovalent ions [xxii] are used. Such sensors operate isothermally in the range of 150 to 450 °C. Another way to improve the selectivity and sensitivity is the change into the

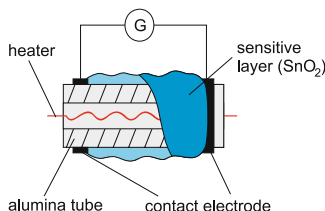

Gas sensors — (c) Metal oxide gas sensors — Figure 7. Gas sensor based on SnO₂ thick-film

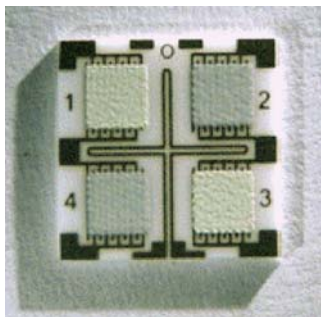

Gas sensors — (c) Metal oxide gas sensors — Figure 8. Layered SnO₂ sensors

dynamic mode. By periodic variation of the sensor operation temperature in a triangular shape and simultaneous sampling of the conductance, additional information of the gas-specific dynamic surface processes is reflected in the resulting conductance-over-time-profiles (CTP). The obtained sensitivities are significantly higher as compared to the signals obtained by isothermal operation mode [xxiii].

In semiconducting oxides such as iron-doped SrTiO₃ (e.g., SrTi_{0.8}Fe_{0.2}O₃) the conductivity depends thermodynamically on the oxygen partial pressure. In the thermodynamic equilibrium a metal oxide exchanges lattice oxygen O_O^x with the ambient gas phase.

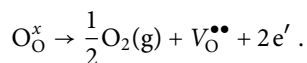

As a result oxygen ion vacancies $\text{V}_\text{O}^{\bullet\bullet}$ and excess electrons e' are formed [xxiv]. On the other hand, by incorporation of oxygen into the lattice, defect electrons (holes) are generated

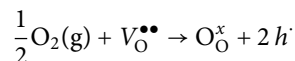

(→ *Kröger-Vink notation* is used for defect equations).

Using the mass action law the concentration of excess electrons $[e']$ and hence the electrical conductivity σ is given by

$$[e'] \propto \sigma \propto \text{const} \cdot p_{\text{O}_2}^{-\frac{1}{4}} \quad \text{or} \quad [e'] \propto \sigma \propto \text{const} \cdot p_{\text{O}_2}^{-\frac{1}{6}}$$

For the concentration of defect electrons (holes) the opposite sign (+1/4 or +1/6) was measured.

Contrary to the SnO₂-based sensors the conductivity of the equilibrated bulk is measured. Due to the establishing of the equilibrium the operating temperature (>500 °C) is much higher than those of SnO₂-sensors. The temperature dependence can be minimized by selection of oxides and by doping [xxv]. It is also possible to measure hydrocarbons by means of such sensors.

Both kinds of resistive sensors are summarized as unstructured gas sensors. Gas-sensitive field effect transistors (gas FET) are called, however, structured gas sensors. The gate of the FET is sensitized by a gas-sensitive layer (e.g., Pd for H₂ FETs, Fig. 9). The gas FET operates preferably in the so-called constant charge mode, in which current and potential are kept constant.

Also organic compound like metal phthalocyanines [xxvi] and electronic conducting polymers [xxvii] are used as gas-sensitive layers in resistive sensors, POSFETs (polymer oxide silicon field-effect transistors), heterojunction diodes (e.g., polypyrrole on

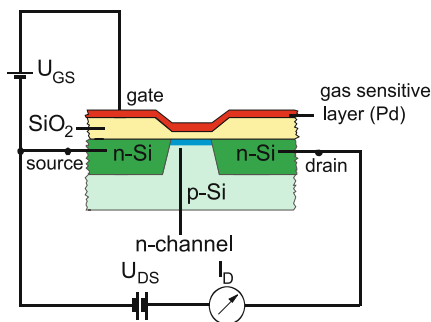

Gas sensors — (c) Metal oxide gas sensors — Figure 9. H₂ FET sensor

n-type Si) and → *Schottky barrier diodes*, respectively. At constant current the voltage of a heterojunction diode is shifted due to the influence of, e.g., NO₂. The junction between the low work function metal and a high work function semiconductor is called Schottky barrier. The deposition of the organic semiconductor can be carried out by chemical and electrochemical polymerization or by spin coating.

Refs.: [i] Möbius HH (1991) *Solid State Electrochemical Potentiometric Sensors for Gas Analysis*. In: Göpel W, Jones TA, Kleitz M, Lundström I, Seiyama T, Hesse J, Zemel JN (eds) *Chemical and biochemical sensors, part I. Sensors, vol 2*. VCH, Weinheim; [ii] Möbius HH, Sandow H, Hartung R, Jakobs S, Guth U, Buhrow J (1992) *Entwicklung neuer Sensorsysteme mit galvanischen Hochtemperatur Festelektrolytzellen*. In: Göpel W, Sandstede G (ed) *Elektrochemische Sensorik*. DECHEMA Monographie 126:329; [iii] Miura N, Raisen T, Lu G, Yamazoe N (1998) *Sens Actuators B* 47:84; [iv] Guth U, Zosel J, Jakobs S, Westphal D, Müller R (2002) *Solid State Ionics* 152–153:525; [v] Zosel J, Ahlborn K, Müller R, Westphal D, Vashook V, Guth U (2004) *Solid State Ionics* 169:115; [vi] Somov SI, Reinhardt G, Guth U, Göpel W (2000) *Sens Actuators B* 65:68; [vii] Somov SI, Guth U (1998) *Sens Actuators B* 47:13; [viii] Schmidt-Zhang P, Zhang W, Gerlach F, Ahlborn K, Guth U (2005) *Sens Actuators B* 108:797; [ix] Gauthier M, Chamberland A (1977) *J Electrochem Soc* 124:1579; [x] Liu J, Weppner W (1991) *Eur J Solid Inorg Chem* 28:1151; [xi] Schäf O, Widmer T, Guth U (1997) *Ionics* 3:277; [xii] Chu WF, Tsagarakis ED, Metzlin T, Weppner W (2003) *Ionics* 9:321; [xiii] Maier J, Warhus U (1986) *J Chem Thermodyn* 18:309; [xiv] Möbius HH (2004) *J Solid State Electrochem* 8:94; [xv] Widmer T, Brüser V, Schäf O, Guth U (1999) *Ionics* 5:86; [xvi] Bredikhin S, Liu J, Weppner W (1993) *Appl Phys A57*:37; [xvii] Diéguez A, Vila A, Cabot A, Romano-Rodríguez A, Morante JR, Kappler J, Barsan N, Weimar U, Göpel W (2000) *Sens Actuators B* 68:94; [xviii] Kanazawa E, Sakai G, Shimano K, Kanmura Y, Teraoka Y, Miura N, Yamazoe N (2000) *Sens Actuators B* 77:72; [xix] Mizuno N, Yoshioka T, Kato K, Iwamoto M (1993) *Sens Actuators B* 13–14:473; [xx] Ivanovskaya M, Bogdanov P, Faglia G, Sberveglieri G (2000) *Sens Actuators B* 68:344; [xxi] Hetzner A, Kohler H, Schönauer U, Guth U (2004) *Sens Actuators B*

99:373; [xxii] Galdikas A, Mironas A, Setkus A (1995) *Sens Actuators B* 26–27:29; [xxiii] Kohler H, Röber J, Link N, Bouzid I (1999) *Sens Actuators B* 61:163; [xxiv] Logothetis EM (1980) *Ceram Eng Sci Proc* 1:281; [xxv] Moos R, Menesklou W, Schreiner H-J, Härdtl K-H (2000) *Sens Actuators B* 67:178; [xxvi] Sadaoka Y (1992) *Organic semiconductor gas sensors*. In: Sberveglieri G (ed) *Gas sensors*. Springer Netherlands, pp 187–218; [xxvii] Potje-Kamloth K (2002) *Crit Rev Anal Chem* 32:121

UG

G

Gas titration

Gas titration, coulometric: – with liquid electrolytes — Specific variant of → *coulometric titration*, where the gaseous sample is absorbed in a reagent solution. An equivalent reagent amount is consumed by reaction with the sample. The reagent loss is compensated by electrolysis current either constant or controlled by a parameter characteristic for the titration progress (e.g., light absorption of an indicator substance or pH). The amount of charge is determined in the course of electrolysis. The main application field is determination of carbon content after combustion to form CO₂. The latter is dissolved in an acidified solution. At a platinum cathode, OH[−] is generated until the original pH has been re-established. Analogous methods exist for determination of SO₂ after absorption in iodine solution.

Other coulometric gas analyzers often are ranked among titrators, although not really a titration is taking place. Most important among them are the → *Hersch cells*, where oxygen or other oxidizing gases are reduced at a noble metal cathode. Hersch cells are galvanic cells, where the electrolysis current is not delivered by an external source, but by dissolution of a → *sacrificial anode* of Zn, Cd, etc.

Ref.: [i] Bishop E (1975) *Coulometric analysis*. In: Wilson CL, Wilson DW (eds) *Wilson and Wilson's comprehensive analytical chemistry, vol. 2D*. Elsevier, New York

PG

Gas titration, coulometric: – with solid electrolytes — The physical principles of the → *coulometric titration* of gases using → *solid electrolyte* → *galvanic cells* are identical to those used in cells with liquid electrolytes. This method is based on a controlled change of the amount of given species in a gas phase near one electrode of the cell, determined from → *Faraday's law*, and on the simultaneous measurement of → *concentration* or → *chemical potential* of reaction products. Most often, the coulometric titration of gases is carried out in the cells with → *oxygen ion* or → *proton-conducting electrolytes*; the cell operation comprises → *electrolysis* of the analyte and/or its chemical reaction with oxygen or → *hydrogen* dosed into the gas phase. The correspond-

ing changes in oxygen or hydrogen chemical potential, which can be measured by electrochemical \rightarrow *sensors*, make it possible to calculate precisely the analyte concentration. Relevant examples include the determination of trace amounts of water vapor, carbon dioxide and/or ammonia in inert gases, the analysis of nitrogen oxides and hydrocarbons, etc. See also: \rightarrow *oxygen pumps*, \rightarrow *hydrogen pumps*, \rightarrow *electrolytic domain*, \rightarrow *oxygen sensors*.

G

A similar technique is used to study the concentration – chemical potential relationships in nonstoichiometric solids. In this case, \rightarrow *solid materials* are to be equilibrated with a gas phase, resulting in adsorption or desorption of a component; the determination of compositional changes in the solid is based on the gas coulometric titration. The relaxation curves may be used to calculate the \rightarrow *exchange currents* and \rightarrow *diffusion coefficients* (see also: \rightarrow *Diffusion: determination in solids*).

Note that the coulometric titration of solid materials can often be performed without an exchange with gas phase, particularly in the case of \rightarrow *cation* \rightarrow *conducting solids*. For this goal, a sample should be placed in contact with a solid electrolyte, where \rightarrow *ions* of the same sort are mobile. The concentration of these ions in the sample may be changed passing direct \rightarrow *current* through the cell. After equilibration, the chemical potential variations can be determined from the cell \rightarrow *EMF* using \rightarrow *Nernst equation*. See also: \rightarrow *Wagner equation*, \rightarrow *Wagner theory*, \rightarrow *Hebb–Wagner method*.

Refs.: [i] Wagner C (1953) *J Chem Phys* 21:1819; [ii] Kröger FA (1964) *The chemistry of imperfect crystals*. North-Holland, Amsterdam; [iii] Rickett H (1982) *Electrochemistry of solids. An introduction*. Springer, Berlin; [iv] Chebotin VN (1989) *Chemical diffusion in solids*. Nauka, Moscow

VK

Gauss, Carl Friedrich



(Apr. 30, 1777, Brunswick, Duchy of Brunswick, now Lower Saxony, Germany – Feb. 23, 1855, Göttingen, Hanover, now Lower Saxony, Germany) Gauss (Gauß)

was a polymath who made profound contributions to many fields, including number theory, analysis, differential geometry, geodesy, magnetism, astronomy, and optics. Gauss attended the Katharinen-Volksschule (1784–1788) and the Gymnasium Catharineum in Braunschweig (1788–1792). His extraordinary mathematical abilities were drawn to the attention of The Duke of Brunswick (Karl Wilhelm Ferdinand, Herzog zu Braunschweig-Lüneburg), whose patronage enabled Gauss to attend the Collegium Carolinum (1792–1795) and the “Georgia Augusta” (Georg-August-Universität) in Göttingen (1795–1798). Gauss was awarded a doctorate from the Universität Helmstedt on July 16, 1799.

While still in college, Gauss proved that any regular polygon whose number of sides is a Fermat prime can (in principle!) be constructed by compass and straight edge. This extended the list of constructible regular polygons for the first time since antiquity, famously including the case $n = 17$ (the heptadecagon). Then, in his 1799 dissertation, Gauss gave a proof of the fundamental theorem of algebra, which states that every polynomial has a root of the form $a + bi$. This was followed in 1801 by his fundamental theorem of arithmetic, which states that every natural number can be represented as the product of primes in just one way. Finally, at age 24, Gauss published one of the greatest achievements in the history of mathematics, his “Disquisitiones Arithmeticae”, in which number theory was systematized for the first time [i]. In 1801, Gauss also developed the method of least squares fitting, some years before Legendre, but unaccountably did not publish it. The method did, however, enable him to calculate the orbit of the asteroid Ceres. This was the start of a life-long pattern. Among several major discoveries that he failed to publish were the concept of non-Euclidean geometry, and the Cauchy integral theorem. Any one of those would have made an ordinary mathematician immortal. Financial insecurity after 1806 (caused by the death of his patron) caused Gauss to seek more regular employment, and in 1807 he was appointed Professor of Astronomy and Director of the astronomical observatory at Göttingen, a post he retained for the rest of his life. In 1831 Gauss began a collaboration with Wilhelm Weber (1804–1891) that involved a thorough investigation of magnetic fields. This led Gauss into a period of practical invention, including the electric telegraph in 1833, and the bifilar magnetometer in 1836. Meanwhile, in 1835, Gauss had formulated his famous law – but did not publish it. Indeed, it did not emerge into the light of day until published by James Clerk Maxwell in 1865 [ii]. In physical chemistry, Gauss’s law gives the relation between

the electric flux flowing through a closed surface and the electric charge enclosed by the surface. (The electric flux is equal to the charge divided by the permittivity.) Oddly, the mathematical function most closely associated with Gauss today – the Gaussian distribution – was actually introduced by Abraham de Moivre in 1734 (in the context of approximating certain binomial distributions for large n). However, Gauss used the distribution in 1809 in his celebrated proof of the method of least squares, and the name has stuck ever since. Gauss was buried in the Albani cemetery in Göttingen. He asked for a heptadecagon on his gravestone, but the stonemason balked! Among his many international honors were Fellowship of the Royal Society (1807), Knight of the Order of the Westphalian Crown (1810), Fellow of the American Academy of Arts and Sciences (1822), Chevalier de Légion d'Honneur (1837), and the Copley Medal (1838).

Refs.: [i] Gauss CF (1801) *Disquisitiones Arithmeticae*. Ger trans (1889) *Untersuchungen über höhere Arithmetik*. Springer, Berlin; Reprinted (1965) by Chelsea, New York; [ii] Maxwell JC (1865) *Philos Trans R Soc London* 155:459

SF

Gel layers — are film-like chemical systems produced through sol-gel chemistry typically on electrode substrates (see → *chemically modified electrodes*). Silica gels have characteristics of both aqueous solutions (in terms of mobility of substances) and rigid molecular sieves (in terms of their structures). Aqueous and nonaqueous (e.g., proton-conducting) polymer gels (e.g., prepared using polyacrylates or polymethacrylates) are also known. Gel layers (or multi-layers) are widely considered as membranes, → *electrochromic devices*, → *sensors*, for → *corrosion protection* and electroceramic applications. They could be in a form of redox-modified siloxane-based crosslinked films on → *carbon*, → *platinum*, and other metal electrode (see → *electrodes, metal*) substrates. Such gel layers were applied to → *electrocatalysis*, amperometric and potentiometric sensing (→ *amperometric sensors*), biosensing, and as reference electrodes. The most common approach to produce thin gel layers utilizes spin-coating or dip-coating step followed by sol-gel processing. Such systems can be further derivatized by encapsulation of charge → *mediators*, silica-based organic-inorganic hybrids, chromophores, metal and organometallic catalysts, preconcentration agents, ionophores, biologically-active compounds, macromolecules, or even bulky dopants capable of stabilizing reactants. Thin-layer gel electrodes with transparent substrates are also used as → *opti-*

cally transparent electrodes or as electrochromic devices (→ *electrochromism*). Thin, scratch-resistant gel layers on metals can exhibit corrosion protection properties. Gel layers are also considered for protection of common electrode substrates against fouling by hydrophobic or surface-active small molecules.

Refs.: [i] Lev O, Wu Z, Bharathi S, Glezer V, Modestov A, Gun J, Rabinovich L, Sampath S (1997) *Chem Mater* 9:2354; [ii] Walcarius A, Mandler D, Cox JA, Collinson M, Lev O (2005) *J Mater Chem* 15:3663; [iii] Kulesza PJ, Cox JA (1998) *Electroanalysis* 10:73; [iv] Ciszowska M, Osteryoung JG (1995) *Anal Chem* 67:1125; [v] Caban K, Lewera A, Zukowska GZ, Kulesza PJ, Stojek Z, Jeffrey KR (2006) *Anal Chim Acta* 575:144; [vi] Lenhard JR, Murray RW (1978) *J Am Chem Soc* 100:7870; [vii] Lenhard JR, Murray RW (1977) *J Electroanal Chem* 78:195; [viii] Kuo K, Moses PR, Lenhard JR, Green DC, Murray RW (1979) *Anal Chem* 51:745; [ix] Guglielmi M (1997) *J Sol-Gel Sci Technol* 8:443; [x] Keller OC, Buffle J (2000) *Anal Chem* 72:936

PK, AL

Gelled electrolyte battery → *sealed battery*

Geometric current density — Current per unit area of the electrode surface. Geometric current density refers to the macroscopic surface area of the electrode as measured from the actual geometric dimensions. Calculating → *current density* based on the geometric area of the electrodes can be misleading. The true active surface area can be bigger than the geometric one due to roughness of the electrode (→ *roughness factor*) surface or due to porosity. Consequently, frequently the geometric current density does not reflect the true current density, which is larger than the real one. On the other hand, due to inhomogeneous current distribution, the active area of the electrode can be smaller than the geometric area. Such situation can often be seen during metal deposition, when the metal growth is dendritic (→ *dendrite growth*). In such cases, the actual current density is larger than the geometric one. Therefore, although calculating geometric current density is straightforward and convenient, the microscopic conditions of the electrode surface and the electrochemical process must be taken into consideration for determination the “true” current density.

Refs.: [i] McCormick M (1993) *Tutorial note 14. Current distribution in electrochemical cells*. *Electron Electr Eng*, De Momfort Univ, Leicester; *Transactions of the Institute of Metal Finishing*; [ii] Ibl N (1983) *Current distribution*. In: Yeager E, Bockris JO', Conway BE (eds) *Comprehensive treatise on electrochemistry*, vol. 3. Kluwer, Amsterdam, p 235–315

OC

Geometric electrode area → *electrode surface area*

Gerischer, Heinz



(Mar. 31, 1919 Wittenberg, Germany – Sep. 14, 1994, Berlin, Germany) Gerischer studied chemistry at the University of Leipzig from 1937 to 1944; Ph.D. thesis with K.F. Bonhoeffer (1946), assistant professor at the Institute of Physical Chemistry at Humboldt University and department head at the Kaiser-Wilhelm-Institut for Physical Chemistry in Berlin-Dahlem (now the Fritz-Haber-Institut of the Max Planck Gesellschaft); 1949, research associate at the Max-Planck-Institut for Physical Chemistry in Göttingen; work on electrode kinetics and new methods (e.g., the double-potential step technique or AC modulation, to measure fast electrode reaction kinetics); 1953, Bodenstein Prize of the Deutsche Bunsen-Gesellschaft; 1954, department head at the Max-Planck-Institut for Metal Research in Stuttgart; habilitation at the University of Stuttgart on the discharge of metal ions; 1957, first publication on → *semiconductor* electrochemistry, 1962, electrochemistry department of Munich University of Technology, 1964, director of the institute of physical chemistry, 1969–1987, director of the Fritz-Haber-Institut der Max-Planck-Gesellschaft (Berlin); 1970, honorary professor of physical chemistry at the Free University and Technical University of Berlin; published more than 300 papers in the areas of electrochemical kinetics, fast reactions in solution and at electrodes, → *electrocatalysis*, metal deposition and corrosion, semiconductor electrochemistry, and → *photoelectrochemistry*; editor of “Advances in Electrochemistry and Electrochemical Engineering” (Wiley Interscience, New York) (with → Tobias CW) 1977–1984, editor of “Advances in Electrochemical Science and Engineering” (VCH, Weinheim) (with C.W. Tobias) 1990–1994.

Refs.: [i] Nozik AJ (1997) *J Phys Chem B* 101:2389; [ii] Lewis NS, Tributsch H, Nozik AJ (1997) *J Phys Chem B* 101:2391; [iii] Kolb DM (1996) *Prog Surf Sci* 51:U3; [iv] Kolb DM (1995) *J Electroanal Chem* 384:1

RH

Gibbs, Josiah Willard



(Feb. 11, 1839, New Haven, CT, USA – Apr. 28, 1903, New Haven, CT, USA) [i, ii] American theoretical physicist and chemist Gibbs was awarded the first Doctor of Engineering in the U.S., and, after studies in Europe (1866–69 in Paris, Berlin, and Heidelberg), he was appointed Professor of Mathematical Physics at Yale in 1871. During his time in Germany he made the acquaintance of G. Kirchhoff and → *Helmholtz*. He developed the fundamental mathematical treatment of thermodynamics (‘On the Equilibrium of Heterogeneous Substances’ 1876 and 1878) [iii]. Gibbs introduced the concept of → *chemical potential*. Since the original publications [iii] appeared in a less widely distributed journal, the translation into German by → *Ostwald, F.W.* [iv] and into French by Le Chatelier [v] made them available for a broader audience. → *Boltzmann* and Gibbs were the founders of statistical thermodynamics; Gibbs was the first who used the expression ‘statistical mechanics’ [vi]. Now the complete work of Gibbs is also available [vii]. The enormous contribution of Gibbs to the development of thermodynamics is recognized by naming several functions, rules, and equations after him: → *Gibbs energy*, → *Gibbs energy of activation*, → *Gibbs energy of ion and dipole transfer*, → *Gibbs adsorption equation*, → *Gibbs–Lippmann equation*, → *Gibbs–Duhem equation*, Gibbs–Helmholtz equation, Gibbs phase rule. See also → *Electrocapillarity*.

Refs.: [i] Magnusson M (ed) (1990) *Chambers biographical dictionary*. W&R Chambers, Edinburgh; [ii] Crystal D (ed) (1998) *The Cambridge biographical encyclopedia*. Cambridge University Press, Cambridge; [iii] Gibbs JW (1876,1878) *Trans Connecticut Acad Arts* 3:108; 343; [iv] Gibbs JW (1892) *Thermodynamische Studien*. Translated by Ostwald W, Leipzig; [v] Gibbs JW (1899) *Équilibre de Système Chimiques*. Translated by Le Chatelier HL. Gabay, Paris (reprinted 2003); [vi] Gibbs JW (1902) *Elementary principles in statistical mechanics developed with special reference to the rational foundations of thermo-*

dynamics. New Haven; [vii] Gibbs JW (1961) *The scientific papers of J Willard Gibbs*. Dover, New York

Gibbs, Oliver Wolcott



(Feb. 21, 1822, New York, USA – Dec. 9, 1908, Newport Rhode Island, USA) [i]. O.W. Gibbs started to study science at the Columbia College in New York in 1837, continued with chemistry at the Medical School of the University of Pennsylvania in Philadelphia in 1841, and further at the College of Physicians and Surgeons in New York where he obtained a Ph.D. in chemistry in 1845. He worked with K.F. Rammelsberg, Heinrich Rose, and Justus von Liebig in Germany and with Jean-Baptiste Dumas in Paris, France. In 1848 he became assistant professor at the College of Physicians and Surgeons, in 1849 full professor of chemistry and physics at the Free Academy in New York (now College of the City of New York), and in 1963 professor for applied sciences at Harvard University, Massachusetts, and head of the chemical laboratory at the Lawrence Scientific School, New York. O.W. Gibbs was the first to suggest a \rightarrow carbon electrode in \rightarrow batteries (1840), and he was the first to suggest \rightarrow electrolysis of metal solutions for the sake of precipitation of the pure metals for a gravimetric determination [ii], i.e., he is the inventor of \rightarrow electrogravimetry.

Refs.: [i] Szabadváry F (1966) *Geschichte der Analytischen Chemie*. Akadémiai Kiadó, Budapest (Engl ed: Szabadváry F (1966) *History of analytical chemistry*. Pergamon Press, Oxford); [ii] Gibbs W (1864) *Fresenius' Z anal Chem* 3:334

RH

applied to the \rightarrow chemical potential (μ_i) is called the Gibbs–Duhem equation [i, ii].

A single phase α consisting of K components with amount of species n_i , apart from its size, can be characterized by the set of intensive quantities: temperature T , pressure p , and μ_i^α . The number of these is $K + 2$, however, the number of degrees of freedom of a single phase is only $K + 1$, and therefore there must be some relation between them corresponding to the identity between mole fractions.

By differentiating the \rightarrow Gibbs energy function

$$dG^\alpha = \sum_i \mu_i^\alpha dn_i^\alpha + \sum_i n_i^\alpha d\mu_i^\alpha \quad (1)$$

and then by subtracting it from the fundamental equation for the variables T, p, n_i

$$dG^\alpha = -S^\alpha dT + V^\alpha dp + \sum_i \mu_i^\alpha dn_i^\alpha \quad (2)$$

we obtain the Gibbs–Duhem relation:

$$S^\alpha dT - V^\alpha dp + \sum_i n_i^\alpha d\mu_i^\alpha = 0. \quad (3)$$

It is particularly useful in its application to changes at constant T and p :

$$\sum_i n_i^\alpha d\mu_i^\alpha = 0. \quad (4)$$

The Gibbs–Duhem equation is used in several cases in electrochemistry, e.g., in the derivation of \rightarrow Gibbs adsorption equation or \rightarrow Gibbs–Lippmann equation; since Eq. (4) can be extended by surface work:

$$A dy + \sum_i n_i d\mu_i = 0 \quad (5)$$

or by using the surface excess concentration, $\Gamma_i = n_i/A$

$$-dy = \sum_i \Gamma_i d\mu_i. \quad (6)$$

Refs.: [i] Guggenheim EA (1993) *Thermodynamics*. North-Holland, Amsterdam, p 25; [ii] Klotz IM, Rosenberg RM (1994) *Chemical thermodynamics*. Wiley Interscience, New York, pp 256–258

GI

FS

Gibbs adsorption equation \rightarrow Gibbs–Lippmann equation

Gibbs–Curie–Wulff theorem \rightarrow equilibrium form of crystals and droplets

Gibbs–Duhem equation — The relationship between partial molar quantities of different components when

Gibbs energy — (also called ‘Gibbs free energy’, or ‘free energy’). The thermodynamic potential for variables T and P is called the Gibbs energy: $G = U - TS + PV$. Calculating its differential, one finds that $dG = -SdT + VdP$.

It follows that if $dT = 0$ and $dP = 0$, then $dG = 0$. This relationship replaces the law of internal energy conservation for systems under isothermic-isobaric conditions. The derivatives of Gibbs energy give \rightarrow entropy

and volume: $(\frac{\partial G}{\partial T})_P = -S$ and $(\frac{\partial G}{\partial P})_T = V$. Gibbs energy is a state function of a thermodynamic system. For homogeneous multicomponent charged systems $dG = -SdT + VdP + \sum_i \tilde{\mu}_i dn_i$, where $\tilde{\mu}_i$ is the \rightarrow *electrochemical potential* and n_i is the number of moles of component i . For a system of two immiscible phases α and β $dG = -SdT + V_\alpha dP_\alpha + V_\beta dP_\beta - Ad\gamma + \sum_i \tilde{\mu}_i dn_i$, where A is the area of the interface and γ is the \rightarrow *interfacial tension*. For electrochemical cells, Gibbs energy change of the \rightarrow *cell reaction* is proportional to the potential of the cell reaction E (\rightarrow *Galvanic cell*) ($\Delta G = -nFE$, where n is the \rightarrow *charge number* of the cell reaction and F is the \rightarrow *Faraday constant*). The configurational Gibbs energy ΔG_c is the part of the Gibbs energy not depending on the transpositional contribution to entropy. The configurational Gibbs energy is different from the standard Gibbs

energy ΔG^\ominus : $\Delta G_c = \Delta G^\ominus + RT \ln \frac{\prod_i X_i^\ominus}{\prod_f X_f^\ominus}$. Here X_i^\ominus and X_f^\ominus are the mole fractions of n initial (i) and m final (f) reagents in their standard states. If the reaction is not accompanied by changes in the number of particles, there is no difference between the standard Gibbs energy and the configurational Gibbs energy. However, if the number of particles changes, for instance, by decomposition of a molecule, the expression for the basic reaction involves only the configurational Gibbs energy which does not include the entropy related to commutation of the particles. ΔG_c is the Gibbs energy of the reaction and it differs from the work of the reaction by the work of mixing reagents depending on the concentration.

Refs.: [i] Volkov AG, Deamer DW, Tanelian DI, Markin VS (1998) *Liquid interfaces in chemistry and biology*. Wiley, New York; [ii] Guggenheim EA (1993) *Thermodynamics*. North-Holland, Amsterdam, pp 22–28; [iii] Klotz IM, Rosenberg RM (2000) *Chemical thermodynamics. Basic theory and methods*. Wiley, New York

AV

Gibbs energy diagram — A diagram showing the relative standard \rightarrow *Gibbs energies* of reactants, \rightarrow *transition states*, reaction intermediates, and products, in the same sequence as they occur in a chemical reaction. These points are often connected by a smooth curve (a “Gibbs energy profile”, commonly still referred to as a “free energy profile”) but experimental observation can provide information on relative standard Gibbs energies only at the maxima and minima and not at the configurations between them. The abscissa expresses the sequence of reactants, products, reaction intermediates, and transition states and is usually undefined or only vaguely defined by the reaction coordinate (extent of bond breaking or bond making). In some adaptations the abscissas

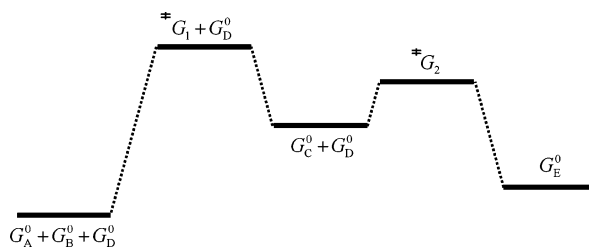

Gibbs energy diagram — Figure

are however explicitly defined as bond orders, Brønsted exponents, etc. The highest point on a Gibbs energy diagram does not necessarily correspond to the transition state of the rate-limiting step. For example, in a stepwise reaction consisting of two reaction steps

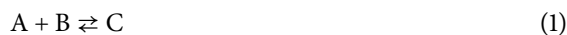

one of the transition states of the two reaction steps must (in general) have a higher standard Gibbs energy than the other, whatever the concentration of D in the system. However, the value of that concentration will determine which of the reaction steps is rate-limiting. If the particular concentrations of interest, which may vary, are chosen as the standard state, then the rate-limiting step is the one of highest Gibbs energy.

(See also \rightarrow *Gibbs J.W.*.)

See also \rightarrow *potential energy profile*, \rightarrow *potential energy (reaction) surface*.

Ref.: [i] Muller P (1994) *Pure Appl Chem* 66:1077

WK

Gibbs energy of activation $\Delta^\ddagger G$ (standard free energy of activation $\Delta^\ddagger G^\ominus$) (kJ mol⁻¹) — The standard Gibbs energy difference between the \rightarrow *transition state* of a reaction (either an elementary reaction or a stepwise reaction) and the ground state of the reactants. It is calculated from the experimental rate constant k via the conventional form of the absolute reaction rate equation:

$$\Delta^\ddagger G = RT[\ln(k_B/h) - \ln(k/T)],$$

where k_B is the \rightarrow *Boltzmann constant* and h the \rightarrow *Planck constant* ($k_B/h = 2.08358 \times 10^{10} \text{ K}^{-1} \text{ s}^{-1}$). The values of the rate constants, and hence Gibbs energies of activation, depend upon the choice of concentration units (or of the thermodynamic standard state). See also \rightarrow *activation energy*, \rightarrow *enthalpy of activation* and \rightarrow *entropy of activation*, \rightarrow *Gibbs J.W.*

Ref.: [i] Muller P (1994) *Pure Appl Chem* 66:1077

WK

Gibbs energy of amalgam formation — When the oxidized and reduced forms of metal ions are soluble, the \rightarrow half-wave potential ($E_{1/2}$) in \rightarrow polarography is very close to the \rightarrow standard potential (E^\ominus). Larger differences (up to 1 V) can arise when the activities and \rightarrow diffusion coefficients of the oxidized and reduced forms differ. Assuming that the activity of \rightarrow mercury in the \rightarrow amalgam does not differ appreciably from that of pure mercury, the following relation holds: $E'_{1/2} = E_M^\ominus - \frac{\Delta G^\ominus}{nF} + \frac{RT}{nF} \ln a_{\text{sat}} + \frac{RT}{nF} \ln \left[\frac{f_{\text{Ox}} D_{\text{Red}}^{1/2}}{f_{\text{Red}} D_{\text{Ox}}^{1/2}} \right]$ (E_M^\ominus – standard potential of the redox system M^{n+}/M , a_{sat} – activity of the metal in the saturated amalgam, f – the activity coefficient, D – the diffusion coefficient) [i]. If the metal is very soluble in mercury and no solid intermetallic compounds formed, then $E'_{1/2}$ is close to E_M^\ominus , since in such a case $\Delta G^\ominus = 0$ and a_{sat} is close to 1. Radiopolarography has been used to access the partial excess Gibbs energies of formation of amalgams of Cm, Bk, Cf, Es, Fm, Md, or No employing as low concentration of these metal ions as 10^{-8} to 10^{-11} mol L $^{-1}$. They were estimated from the polarographic half-wave potentials. Such estimations would not be possible with typical thermodynamic techniques used for macro amounts of these metals [ii]. Such electrochemical determination of ΔG^\ominus in the formation of different amalgams is often used [iii].

(See also \rightarrow Gibbs J.W.)

Refs.: [i] Galus Z (1994) *Fundamentals of electrochemical analysis*, 2nd edn. Ellis Horwood, New York, Polish Scientific Publisher PWN, Warsaw; [ii] Gumiński C (2002) *Amalgams*. In: Westbrook JH, Fleischer RL (eds) *Intermetallic compounds*, vol. 3. Wiley, Chichester; [iii] Ryabuchin AG (2001) *Proceedings of the Chelyabinsk Scientific Center* 3:40 (in Russian)

BY

Gibbs energy of ion and dipole transfer — The standard \rightarrow Gibbs energy of ion transfer (see also \rightarrow ion transfer at liquid–liquid interfaces) can be represented as the difference of two \rightarrow solvation energies: $\Delta_\beta^\alpha G_i^\ominus = \Delta_{\text{vac}}^\alpha G_i^\ominus - \Delta_{\text{vac}}^\beta G_i^\ominus = -\frac{\Delta_\beta^\alpha \phi_i^\ominus}{z_i F}$, where $\Delta_\beta^\alpha \phi_i^\ominus$ is the standard potential for transfer of ion i from α to β phase. If two immiscible liquids α and β are mutually saturated, a certain amount of one solvent will be dissolved in the other solvent and *vice versa*. The corresponding energy of Gibbs free energy of ion transfer between two mutually balanced solvents is called the free partition energy. The main contributions to the energy of ion or dipole transfer between two solvent phases are (i) electrostatic \rightarrow polarization of the medium; (ii) production in a medium of a cavity to accommodate the ion or dipole also known as the solvo-

phobic, hydrophobic (or neutral) effect (\rightarrow solvophobicity, \rightarrow hydrophobic effect); (iii) changes in the structure of the solvent that involve the breakdown of the initial structure and the production of a new structure in the immediate vicinity of the ion; (iv) specific interactions of ions or dipoles with solvent molecules, such as hydrogen bond formation, donor–acceptor and ion–dipole interactions; (v) annihilation of defects: a small ion may be captured in a “statistical micro-cavity” within the local solvent structure so far releasing energy of this defect; (vi) the correction term for different standard states. Gibbs free energy of ion or dipole transfer can be represented as a sum of all contributions: $\Delta G(\text{tr}) = \Delta G(\text{el}) + \Delta G(\text{svph}) + \Delta G(\text{si})$, where $\Delta G(\text{si})$ is caused by specific interactions of the transferred particle (ion, dipole) with solvent molecules, such as hydrogen bond formation, donor–acceptor and ion–dipole interactions. The ion resolution energy can be calculated or measured by two methods. In the \rightarrow Born theory (\rightarrow Born solvation energy), the electrical part of Gibbs free energy of ion transfer is given by the relation: $\Delta_\beta^\alpha G^\ominus(\text{el}) = -\frac{z^2 e_0^2}{8\pi \epsilon_0 a} \left(\frac{1}{\epsilon^\beta} - \frac{1}{\epsilon^\alpha} \right)$. The solvophobic contribution to the resolution energy: $\Delta_\beta^\alpha G^\ominus(\text{svph}) = -4\pi a^2 \gamma_{\alpha\beta} \text{sgn}(\gamma_\alpha - \gamma_\beta)$. The solvophobic contribution to the Gibbs free energy of ion or molecule (dipole, multipole) transfer from water to hydrocarbon is negative and the absolute value is obviously greater for particles with larger radii. Some deviation from the solvophobic formula is observed if the interfacial tension of two pure immiscible solvents is less than 10 mN m $^{-1}$ and if the size of the dissolved particle is less than 0.2 nm. The electrostatic part of Gibbs free energy of dipole transfer from phase w to phase m : $\Delta_w^m G(\text{el}) = \frac{\mu^2}{12\pi \epsilon_0 l^3} \left(\frac{\epsilon_w - 1}{2\epsilon_w + 1} - \frac{\epsilon_m - 1}{2\epsilon_m + 1} \right) = \frac{\mu^2}{4\pi \epsilon_0 l^3} \left(\frac{\epsilon_w - \epsilon_m}{(2\epsilon_w + 1)(2\epsilon_m + 1)} \right)$, where μ is the \rightarrow dipole moment and l is the effective dipole size.

(See also \rightarrow Gibbs J.W.)

Refs.: [i] Volkov AG, Deamer DW, Tanelian DI, Markin VS (1998) *Liquid interfaces in chemistry and biology*. Wiley, New York; [ii] Markin VS, Volkov AG (1989) *Electrochim Acta* 34:93

AV

Gibbs–Lippmann equation — The relationship between the \rightarrow interfacial tension (γ) and the surface excess quantities was derived by \rightarrow Gibbs, J.W. At constant temperature (T) and external pressure (p)

$$-d\gamma = \sum_\alpha \sum_i \Gamma_i^\alpha d\mu_i^\alpha, \quad (1)$$

where Γ_i^α is the surface excess amount (surface concentration in mol m $^{-2}$) of the group of species i in phase α ,

β etc., and μ_i is the \rightarrow chemical potential of these species in the different phases. (The summation is over all the chemical species i , except one which is selected as a reference component.) Since in Eq. (1) γ is used, the equation is valid for fluid phases. For phases including a solid $d\gamma$ has to be replaced by surface energy (see \rightarrow interfacial tension). For charged interfaces (adsorption of charged species)

$$-d\gamma = \sum_{\alpha} \sum_i \Gamma_i^{\alpha} d\tilde{\mu}_i^{\alpha}, \quad (2)$$

where $\tilde{\mu}_i$ is the \rightarrow electrochemical potential of species i in phase α .

For \rightarrow ideally polarizable electrodes

$$\sigma^{\alpha} = \sum z_i F \Gamma_i^{\alpha} = -\sigma^{\beta} = -\sum z_i F \Gamma_i^{\beta}, \quad (3)$$

where z_i is the charge number of an ion or electron, F is the \rightarrow Faraday constant, and σ^{α} and σ^{β} are the free surface charge densities on phases α and β , respectively, in $C m^{-2}$.

For ideally \rightarrow non-polarizable electrodes

$$Q_A^{\alpha} = z_A F \Gamma_A^{\alpha}, \quad (4)$$

where Q_A^{α} is the total surface charge density on phase α . For ideally polarizable electrodes [e.g., mercury immersed in a KA electrolyte containing also neutral solvent (H_2O) and other neutral molecules (B)]

$$-d\gamma = \sigma^{\alpha} dE_{(-)} + \Gamma_{K^{+}(H_2O)}^{\beta} d\mu_{KA}^{\beta} + \Gamma_{B(H_2O)}^{\beta} d\mu_B, \quad (5)$$

where $E_{(-)}$ is the electrode potential with respect to reference electrode reversible to the anion (A^{-}), $\Gamma_{K^{+}(H_2O)}^{\beta}$ and $\Gamma_{B(H_2O)}^{\beta}$ are the surface excesses relative to the solvent, μ_{KA} and μ_B are the chemical potentials of the neutral combination of KA (e.g., a salt) and molecules B, respectively. This equation is called Gibbs–Lippmann or electrocapillary equation.

$$-\left(\frac{\partial\gamma}{\partial E_{(-)}}\right) = \sigma^{\alpha} \quad (6)$$

is the \rightarrow Lippmann equation, while

$$-\left(\frac{\partial\gamma}{\partial\mu_{KA}^{\beta}}\right)_{E_{(-)},\mu_B} = \Gamma_{K^{+}(H_2O)}^{\beta} \quad (7)$$

is the **Gibbs adsorption equation**. Equation (7) is often used in the form

$$\Gamma_{K^{+}(H_2O)}^{\beta} = -\frac{1}{RT} \left(\frac{\partial\gamma}{\partial \ln a_{KA}^{\beta}}\right)_{p,T,E,\mu_B} \quad (8)$$

expressing the relationship between the activity (concentration) and the surface excess, where R is the \rightarrow gas constant, and a_{KA} is the relative \rightarrow activity of the electrolyte KA.

For nonpolarizable electrodes ($\partial\gamma/\partial E$) gives Q_A the value of which depends on the choice of reference component. Various cross-differential relationships can also be obtained (see \rightarrow Esin–Markov coefficient).

Refs.: [i] Guggenheim EA (1967) *Thermodynamics*. North-Holland, Amsterdam, pp 45–50; [ii] Linford RG (1978) *Chem Rev* 78:81; [iii] Trasatti S, Parsons R (1986) *Pure Appl Chem* 58:437; [iv] Bard AJ, Faulkner LR (2001) *Electrochemical methods*, 2nd edn. Wiley, New York, pp 534–544

GI

Glass electrode — An electrode (sensor) for the measurement of ion, especially hydronium (\rightarrow pH) and alkali ion (pNa) \rightarrow activities in aqueous [i], and, less often, nonaqueous solutions. Glass electrodes are also applicable for measuring deutonium (D_3O^{+}) (pD values) and sodium activities in heavy water (D_2O) solutions [ii].

The functioning of glass electrodes is based on the formation of electrical \rightarrow potential differences between certain and, in principle all, oxidic glasses and contacting aqueous solutions, which was detected by Cremer in 1906. Since, in contrast to metal electrodes, glass is a \rightarrow solid electrolyte that cannot simply be connected to the terminals of a measuring instrument by a metal wire, the two-phase system solution/glass is extended by other phases to become a complete electrochemical cell with two metal terminals, whose \rightarrow Galvani potential difference (earlier: \rightarrow electromotive force, emf) can be measured. consists of the sum of all potential differences between the added phases according to the cell scheme

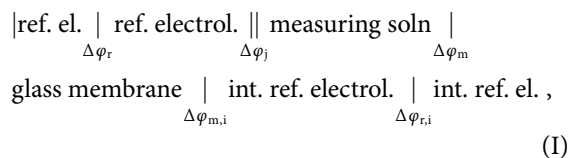

where $\Delta\varphi$ is the Galvani potential difference between reference electrode and reference electrolyte (index r), reference electrolyte and measuring solution (a diffusion voltage indicated by a double bar, index j), measuring solution and glass membrane (index m), glass membrane and internal reference solution (index m, i), and internal reference electrolyte and electrode (index r, i). Except for $\Delta\varphi_m$, the potential difference of interest, the potential differences are kept constant (merely $\Delta\varphi_j$ is subject to small solution-dependent changes), so that the cell potential difference is a function of the measuring solution

and thus of its pH, pM or pD, as the case may be, for example $\Delta_{\alpha}^{\beta} \varphi = f(\text{pH})$ if alkali and deuterium ions are absent.

In practice, glass electrodes are closed tube-, tablet-, or any other shaped bodies of the ion-sensitive membrane glass with a several tenths of a millimeter-thick wall melted to a high resistance glass shaft tube, which also contains the internal reference electrode and solution. As cell scheme (I) demonstrates, practical glass electrode cells either consist of a single glass and a reference electrode both dipping into the solution of interest, scheme (Ia),

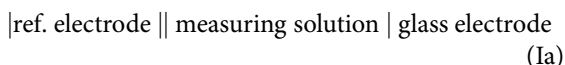

or of a single rod or combination electrode combining both glass and reference electrode in one electrode shaft, scheme (Ib),

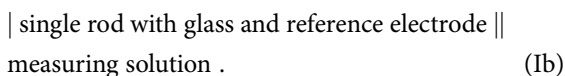

Glass electrode cells must be calibrated by means of standard pH (or pM) buffer solutions (see \rightarrow pH or pH value), by which the electrode isotherm is determined. Within the range of medium pH values ($\text{pH} < 1$ to > 10), the isotherm is a linear function with slightly smaller than ideal slope (see \rightarrow dissociation mechanism), which, outside this range, shows slight deviations, the less significant negative acid error and the positive or salt error, indicating the onset of alkali sensitivity of the membrane glass.

Points of further interest: Besides normal-size-, also mini- and micro-glass electrodes are applied according to the available volume of measuring solution. Micro-electrodes are applied within single cells of, e.g., living tissue and are generally constructed from extremely thin membrane glass capillaries by the applying researchers. Solid metallic and other internal contacts have been tried but were unsuccessful so far, mostly because of principle reasons. Membrane glasses for redox measurements have not been successful either.

Refs.: [i] Baucke FGK (2000) *Electrochemistry of solid glasses*. In: Bach H, Baucke FGK, Krause D (eds) *Electrochemistry of glasses and glass melts, including glass electrodes*. Springer, Berlin, pp 35–268; [ii] Baucke FGK (1998) *J Phys Chem B* 102:4835

FB

Dissociation mechanism (mechanism of response of the glass electrode) — The mechanism of an electrode response is the electrochemical process

between electrode and solution that causes a measurable solution-dependent electrical \rightarrow potential of the electrode. Different from metal-metal ion and redox electrodes, the potential difference between a glass electrode membrane, a \rightarrow solid electrolyte, and an \rightarrow electrolyte solution is caused by an interfacial ionic process [i]. During the first decades after the potential difference between glasses and solutions had been discovered by Cremer in 1906, it was tried to understand the new effect by applying the then available nonspecific analytical methods on the basis of thermodynamics. This work yielded theories and hypotheses, some of which describe the glass electrode function amazingly well, but it could not yield any knowledge about the physical processes at and in the membrane glass. The response mechanism thus remained unknown. This unfortunate state changed only in the mid-seventies when sufficiently sensitive depth-resolving quantitative analytical methods had become available. Especially IBSCA (ion bombardment for spectrochemical analysis) and NRA (nuclear reaction analysis) in combination with other chemical and electrochemical methods were applied. But, surprisingly, the old thinking continued, and corrections for faulty explanations and even new theories were invented after the glass electrode mechanism had been experimentally verified. The thermodynamically based work continues even today in some places despite the knowledge that, in principle, thermodynamics can neither prove nor disprove reaction mechanisms.

The modern work has shown that the glass electrode response is based on an interfacial equilibrium between functional glass groups R (e.g., SiO or [SiOAl]) at the glass surface (s) and thus in contact with the solution and hydronium (H_3O^+) and/or alkali (M^+) ions in the solution (soln). Depending on glass composition and relative \rightarrow pH and pM, it causes the neutral acid (RH) and/or the salt (RM) form of the surface groups, whose dissociation results in a minute concentration of the anionic, negatively charged, component R^- , which is thus determined by the pH and/or the pM of the solution. This dependence, $c'_{\text{R}^-} = f(\text{pH}, \text{pM})$, is the key to understanding the glass electrode response because the anionic groups represent a negative charge density at the glass surface and thus a (negative) potential of the glass membrane relative to the potential of the solution: the potential difference between glass and solution is a quantitative function of the solution composition, $\varepsilon_{\text{m}} = f(\text{pH}, \text{pM})$. This mechanism is also valid in heavy water (D_2O), where pD and $\text{pM}(\text{D}_2\text{O})$ are of interest [ii].

Dissociation and association of the glass surface groups, which are represented by their coupled equilib-

ria, Eqs. (1a) and (1b),

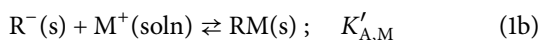
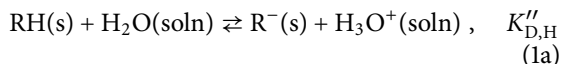

have rather different glass-dependent equilibrium constants. Silicate glasses are distinguished by small dissociation constants, $K''_{\text{D,H}}$, whereas aluminosilicate glasses have large association constants, $K'_{\text{A,M}}$. The equilibria, Eqs. (1a) and (1b), are thus rather well separated so that one of the equilibria is usually favored. The heterogeneous equilibrium constants are still unknown, but correlated relative couples have been estimated. For example, for a lithium silicate pH glass correlated constants were found to be $K''_{\text{D,H}} \leq 10^{-16} \text{ mol kg}^{-1}$ and $K'_{\text{A,Li}} \geq 10^4 \text{ kg mol}^{-1}$ yielding the “selectivity product” ($K''_{\text{D,H}} K'_{\text{A,Li}} \approx 10^{-12}$). The difference between this mechanistic selectivity product and the ion exchange constant according to the ion exchange theory is that the latter is a non-dividable equilibrium constant between hydrogen and alkali ions, which are believed to form a common ion exchange equilibrium. The coupled equilibria, Eqs. (1a) and (1b), on the contrary, demonstrate the existence of two equilibria, which are linked by the common charged surface groups R^{\ominus} , but can also exist independently, e.g., the acid dissociation equilibrium, Eq. (1a), when alkali ions are absent.

For example, a thermodynamic treatment of the acid dissociation equilibrium, Eq. (1a), yields Eq. (2)

$$\begin{aligned} \varepsilon_{\text{m}} &= \varepsilon_{\text{H}}^0 + \frac{RT}{F} \ln \frac{a'_{\text{R}^{\ominus}} a_{\text{H}_3\text{O}^+}}{a'_{\text{RH}^{\ominus}} a_{\text{H}_2\text{O}}} \\ &= \varepsilon_{\text{H}}^0 + k \log \frac{a'_{\text{R}^{\ominus}}}{a'_{\text{RH}^{\ominus}} a_{\text{H}_2\text{O}}} - \text{pH} \end{aligned} \quad (2)$$

which describes the linear pH dependence of the membrane glass potential as it is usually known. Equation (2) also indicates that the potential of the glass is determined by the minute concentration of the dissociated groups R^{\ominus} , which are bound to the glass surface and contacted by the solution. The number of hydrogen ions released by the dissociation is equal to the minute number of anionic groups and does thus not change the pH of the solution in any detectable way. They do not take part in the formation of the potential difference either because they belong to the solution only, which is basically different from the state of the R^{\ominus} groups at the phase boundary.

The glass/solution equilibria, Eqs. (1a) and (1b), are examples of ‘heterogeneous ionics’, which describes the

interaction of solid and liquid electrolytes. Most important in this connection is the redox property of the glass surface groups (R) to exist as neutral (RH and RM) and as charged groups (R^{\ominus}) at the glass surface, as they not only present the basis for the potential formation but also reveal surprising properties of glass electrodes.

- (A) Due to the negative potential of the glass, the heterogeneous dissociation (association) constants are smaller (larger) by orders of magnitude than corresponding constants in homogeneous solution. The concentration of R^{\ominus} groups is thus minute. This ‘electrochemistry’ effect arises from the competing chemical and electrical driving forces simultaneously establishing the equilibrium.
- (B) It is usually assumed that glass electrodes exhibit an ‘ideal slope’, $k = 2.303RT/F$, of their pH- and pM-dependent potential. However, rigorous examination reveals that the theoretical slope must necessarily be smaller than ideal, $k' < k$, because changes of the hydronium (and alkali) ion activity are connected with activity changes of the other participants in the equilibrium. This reduces noticeably the ideal slope, $d\varepsilon_{\text{m}}/d\text{pH} = k$, to a smaller value, Eq. (3),

$$\frac{d\varepsilon_{\text{m}}}{d\text{pH}} = - \left[1 - \frac{d}{d\text{pH}} \left(\log \frac{a'_{\text{R}^{\ominus}}}{a'_{\text{RH}^{\ominus}} a_{\text{H}_2\text{O}}} \right) \right] k \quad (3)$$

so that the thermodynamically correct expression for the pH-dependent glass electrode potential is given by Eq. (4)

$$\varepsilon_{\text{m}} = \varepsilon_{\text{H}}^0 - \left(1 - \frac{d \log a'_{\text{R}^{\ominus}}}{d\text{pH}} \right) k\text{pH} \quad (4)$$

- (C) The ‘subideal response’ in the brackets of Eq. (4) provides a quantitative thermodynamic explanation of the experimental ‘sub-Nernstian response’ αk ($\alpha = 0.999$ to 0.995) in Eq. (5),

$$\varepsilon_{\text{m}} = \varepsilon_{\text{H}}^0 - \alpha k\text{pH} = -(1 - n)k\text{pH}, \quad (5)$$

which was first reported by Bates, who termed α ‘electromotive efficiency’ [iii]. However, the difference with respect to unity, $n = (1 - \alpha) = d \log a'_{\text{R}^{\ominus}} / d\text{pH}$, see Eqs. (4) and (5), called ‘electromotive loss factor’, is more appropriate because it yields detailed information about the heterogeneous equilibrium [iv]. ($n = 0.001$ to 0.005 , mean value $n = 0.0025 \pm 0.0013$).

- (D) The electromotive loss factor n yields details of the interfacial equilibrium which have hitherto been unknown. Thus, a combination of $n = d \log a'_{R^-} / dpH$ and the practical electrode slope $(1-n)k$, which is between 58 and 59.1 mV (25 °C), gives the 'internal slope' $d\varepsilon_m / d \log a'_{R^-} = -(1-n)k/n$. Depending on n , it amounts to between -11.8 and -59.1 volt; for the average $n = 0.0025$, it is 23.6 volt. n thus divides the practical electrode slope into a minute, more 'chemical', and a very large, more 'physical', part of the equilibrium. n is a finite quantity, $n > 0$, that can approach but cannot be equal to zero.
- (E) The electromotive loss factor n yields also the relative activity change of the charged surface groups as a function of pH change, Eq. (6),

$$\Delta c'_{R^-} / c'_{R^-,2} = (c'_{R^-,1} - c'_{R^-,2}) / c'_{R^-,2} = 10^{n(pH_1 - pH_2)} - 1, \quad (6)$$

where concentrations replace activities because of their small changes. Equation (6) states quantitatively the minute changes of the surface groups, for example, $\Delta c'_{R^-} / c'_{R^-,2} = \pm 0.58\%$ for $\Delta pH = \pm 1$. n also shows the wide pH range available for measurements; for example, a change of $\Delta pH = 10$ causes a concentration change of the negative surface groups of only 5.9%. It also follows from Eq. (6) that the practical electrode slope, $d\varepsilon_m / dpH$, is linear, independent of the pH, as experimentally observed. However, the linearity is not a matter of first principles, as always believed, but is a consequence of the assumed constant activity coefficient of the surface groups.

- (F) The state of the glass membrane surface reflects two different functions of the surface groups.
- (a) Practically 100% of the surface groups, whose absolute concentration, however, is unknown, exist as neutral components RH and/or RM. Their relative mole fractions x' are determined by the pH and pM according to Eq. (7),

$$x'_{RM} = 1 - x'_{RH} = \left[\frac{1}{K''_{DH} K'_{AM}} \left(\frac{a_{H_3O^+}}{a_{M^+}} \right) + 1 \right]^{-1} \quad (7)$$

which shows that $x'_{RH} = 1$ at pure pH, $x'_{RM} = 1$ at pure pM, and $(x'_{RH} + x'_{RM}) = 1$ at

mixed pH/pM selectivity. Thus, the selectivity is given by the relative mole fraction of the neutral surface groups, independent of the potential difference of the glass membrane.

- (b) On the contrary, potential changes of the membrane are determined by the minute concentration changes of the charged groups R^- with ΔpH and/or ΔpM , Eq. (8),

$$\Delta \log c'_R = n(\Delta pH \text{ and/or } \Delta pM), \quad (8)$$

where the proportionality constant is the electromotive loss factor n . Thus, the membrane potential is not invariably coupled to the selectivity.

Refs.: [i] Baucke FGK (1996) *Ber Bunsenges Phys Chem* 100:1466; [ii] Baucke FGK (1998) *J Phys Chem B* 102:4835; [iii] Baucke FGK (1994) *Anal Chem* 66:4519; [iv] Baucke FGK (2001) *Phys Chem Glasses* 42:220; [v] Baucke FGK (2000) *Electrochemistry of solid glasses*. In: Bach H, Baucke FGK, Krause D (eds) *Electrochemistry of glasses and glass melts, including glass electrodes*. Springer, Berlin, pp 35-268

FB

Glass capillaries for polarography — Typical glass capillary of **classical shape** (vertical, cylindrical) is 15–20 cm long, external and internal diameters are about 5–7 mm and 20–70 μm . The typical drop time is between 3–10 sec with the mercury column height of ca. 25–80 cm at potentials near the electrocapillary maximum (\rightarrow *electrocapillary curve*). The increasing length and/or decreasing diameter of the capillary slow down the mercury flow and the drop time is therefore longer. The shift of the potential towards negative values results in shorter drop time at the same mercury flow rate (due to decreasing surface tension) (\rightarrow *drop weight method*).

Other commonly used capillaries:

\rightarrow **Smoler type** – the end (tip) of the capillary is bent 45° (inclined) to 90° (horizontal). The drop time is shorter, the reproducibility is better, the solution around the orifice is more efficiently renewed, hence the current at the next drop is unaffected by the depletion of solution near the capillary, moreover, the eventual insoluble products are totally removed (i).

Spindle capillary (Novotný type) is manufactured from a classical cylindrical capillary. The length and the diameter of the upper narrow, cylindrical part of the capillary controls the mercury flow. The inner space in the lower part has the shape of an unsymmetrical spindle with its longer end pointing downwards. This shape of the inner part of the capillary prevents penetration of the solution into the orifice; the capillary exhibits then

higher reproducibility of the drop time, better stability and durability (ii).

For → *hanging mercury drop electrode* (HMDE) or for → *static mercury drop electrode* (SMDE) the cylindrical glass capillaries are 10–15 cm long with internal diameter 100–150 μm. These parameters enable a very fast flow of mercury. The drop is formed very quickly, then the mercury flow is stopped by an electromagnetic needle-like stopcock and the surface of the drop is kept constant during measurement.

Ref.: [i] Smoler I (1963) *J Electroanal Chem* 6:465; [ii] Novotny L, Heyrovsky M (1987) *Trends Anal Chem* 6:176

JL

Glassy carbon electrode — an electrode utilizing glassy carbon substrate. Glassy carbon (also called vitreous carbon) is an advanced material of pure → *carbon* combining glass-like mechanic characteristics with physical properties of → *graphite*. It features carbon that cannot be transformed into crystalline graphite even at temperatures of 3000 °C. In addition to the above-mentioned resistance to high temperature, it is also extremely resistant to many chemicals, it is impermeable to gases and liquids, has good electric conductivity, low density, high hardness, and high strength. Only strong oxidizing agents like oxygen at elevated temperature, or hot melts, or strong oxidizing acids can attack glassy carbon. But even under such conditions it is probably the most inert carbon material. Glassy carbon can be shaped to produce many forms. Thus it is widely used as an electrode material in electrochemistry. Its biocompatibility makes it attractive as a component of prosthetic devices.

It was first produced in the early 1960s by The General Electric Company, UK, by using cellulose as a substrate. Present techniques of preparation of glassy carbon utilize such organic substrates as phenolic resins and involve controlled pyrolysis in inert atmosphere at temperatures ranging between 1000 and 3000 °C.

Ref.: [i] Harris PJF (2004) *Philos Mag* 84:3159 and references therein

PK, AL

Glassy (amorphous) metals — Metallic alloys that are nearly X-ray amorphous with a crystalline structure in the nanometer range. Such a state is very rarely reported for single metals. Glassy/amorphous metals can be obtained, among others, by rapid cooling (quenching) and → *electrolysis*. Very thin layers of such metals also can be obtained by ion bombardment/implantment. Interest in glassy metals is related to the fact that these alloys often have better corrosion, surface, and mechanical properties than the corresponding macro-crystalline

forms. Good examples of glassy metals are the alloys of tungsten with iron group metals.

Refs.: [i] Lemley B (2004) *Discover* 25 No. 04, [ii] <http://www.metglas.com>, [iii] Brookes HC, Carruthers CM, Doyle TB (2005) *J Appl Electrochem* 35:903

ZS

Glove box technique — A glove box is a device that enables to work with materials which are sensitive to atmospheric components, under inert atmosphere (Ar, N₂, or dry air depending on need and reactivity of materials).

It includes the following major parts:

1. A box constructed of aluminum or stainless steel (depending on materials, pressure applied, temperature range, etc.), which maintains an inert atmosphere and serves as the working area.
2. A transparent window (the most practical material is polycarbonate), to which rubber gloves are attached. The work is being carried out in the box through the gloves.
3. A vacuum chamber with a vacuum pump through which tools and materials are transferred in and out to/from the box.
4. A system which circulates the inert atmosphere in the box, through sets of absorbents.

For most common operation, H₂O and O₂ traces are removed, using columns of molecular sieves and active catalysts (respectively).

It is possible to remove nitrogen and organic solvents as well, using appropriate absorbing columns. This system includes the appropriate sensors and regeneration cycles.

5. A system for pressure control and inert gas supply, which includes all the necessary valves.

Modern glove boxes include central computerized units that monitor pressure and level of contaminants and automatically initiates regeneration of the contaminant removal system when needed.

Glove boxes may be designed to contain high temperature ovens, sensitive systems, spectrometers, spattering units, and more. They can be designed for both research and production purposes. A commonly used glove box is depicted below.

Refs.: [i] Aurbach D (1999) *Nonaqueous electrochemistry*. Marcel Dekker, New York; [ii] Kissinger PT, Heineman WR (1996) *Laboratory*

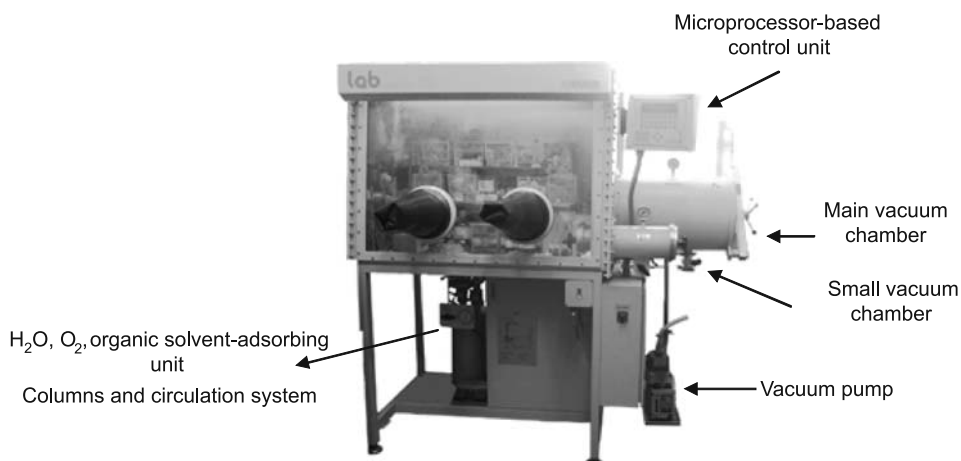

Glove box technique — Figure

techniques in electroanalytical chemistry, 2nd edn. Marcel Dekker, New York; [iii] Mbraun.de/about_mbraun.htm

DA

Glow discharge electrolysis → plasma electrochemistry

Glucose oxidase — (EC 1.1.3.4) The systematic name is β -D-glucose:oxyg \ddot{e} n 1-oxidoreductase. Synonyms are GOD, notatin, glucose oxyhydrase, and D-glucose-1-oxidase. Glucose oxidase belongs to the GMC (glucose-methanol-choline)-oxidoreductases family of proteins, which are all flavoprotein enzymes. The enzyme is produced predominantly by *Aspergillus* and *Penicillium* species but also found in other fungi and in bacteria, plants, and animals. The most widely used GOD from *Aspergillus niger* is a homodimer of 160 kDa consisting of about 74% protein and 16% carbohydrates and 1 mol tightly bound flavin adenine dinucleotide (FAD) per subunit, which acts as a redox carrier in catalysis. Each subunit consists of two domains, an N-terminal FAD-binding domain and a C-terminal substrate-binding domain. Glucose oxidase catalyzes hydrogen transfer from β -D-glucose to molecular oxygen, thereby forming δ -D-gluconolactone and hydrogen peroxide according to the following reaction:

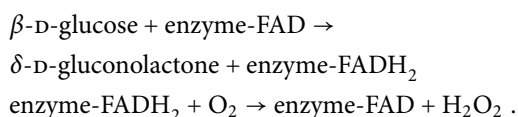

The enzyme is highly specific for β -D-glucose. 2-Deoxy-D-glucose, D-mannose, D-xylose, and D-galactose exhibit low activities as substrates.

Oxygen can be replaced by other (natural and synthetic) electron acceptors. The enzyme is widely applied in → biosensors, such as → enzyme electrodes, for the quantitative determination of β -D-glucose in body fluids. See also → glucose sensors.

Refs.: [i] Gibson QH, Swoboda BEP, Massey V (1964) *J Biol Chem* 239:3927; [ii] Bright HJ, Porter DJT (1975) *Flavoprotein oxidases*. In: Boyer PD (ed) *The enzymes*, 3rd edn. vol. 12. Academic Press, New York, p 421; [iii] Hecht HJ, Kalisz HM, Hendle J, Schmid RD, Schomburg D (1993) *J Mol Biol* 229:153; [iv] <http://www.worthington-biochem.com/GOP>; [v] <http://www.brenda.uni-koeln.de/index.php4>

UW

Glucose sensor — A glucose sensor is a device that detects or measures glucose. It is a chemosensor or → biosensor which consists of a glucose-specific recognition element and a transducer (see → biosensor) which converts the recognition event into a measurable signal whose magnitude is proportional to the concentration of glucose. In this sense it shall be distinguished from the biological glucose sensors regulating the metabolism. Glucose-specific recognition elements are enzymes, sugar-binding proteins, and whole cells, and also synthetic binders. Most often used transducers are → electrochemical sensors, optoelectronic detectors, and thermistors. Predominantly used in electrochemical glucose sensors are enzymes such as → glucose oxidase (GOD) and mediator-dependent glucose dehydrogenase, but also NAD(P)H-dependent glucose dehydrogenase and hexokinase and additionally coupled peroxidase.

Different configurations are found. The enzymes are immobilized in membranes and placed onto the elec-

trode or they are coupled directly to the surface of an electrode (enzyme \rightarrow *chemically modified electrode*) or integrated in the bulk of the electrode itself (see also \rightarrow *enzyme electrode* and *carbon paste electrode*). Oxygen consumption, hydrogen peroxide formation, oxidation of the reduced electron acceptor (\rightarrow *mediator*), or direct oxidation of the enzyme generates the measuring signal. Typical examples of electrochemical glucose sensors are

- (a) the amperometric glucose enzyme electrode using glucose oxidase coupled to a \rightarrow *Clark oxygen electrode*, where GOD is immobilized in a membrane and fixed on the electrode; enzymatic glucose conversion results in oxygen consumption and peroxide formation according to: $\text{glucose} + \text{enzyme-FAD} \rightarrow \text{gluconolactone} + \text{enzyme-FADH}_2$; $\text{enzyme-FADH}_2 + \text{O}_2 \rightarrow \text{enzyme-FAD} + \text{H}_2\text{O}_2$

This reaction is followed by the electrode, to which a potential is applied either for reduction of oxygen (-600 to -800 mV versus Ag/AgCl) or oxidation of hydrogen peroxide ($+600$ to $+800$ mV versus Ag/AgCl). The resulting current is proportional to the glucose concentration. The earliest description of a glucose electrode by Clark and Lyons used this principle and was later used in several commercial glucose analyzers. However, the analysis is hampered by two major limitations. Firstly, the current will depend not only on glucose but also on the partial oxygen tension of the solution. Variations of the oxygen level will restrict the application, in particular in the case of implantable glucose sensors. Furthermore, at the potential required for peroxide oxidation, other coexisting electroactive substances in biological fluids, such as ascorbic acid, uric acid, and acetaminophen, may be oxidized and thus contribute to the signal. One way to improve the glucose measurements is to replace the oxygen by a nonphysiological electron acceptor, for example, organic and organometallic redox compounds such as ferrocene and quinone derivatives, osmium and ruthenium complexes, ferricyanide, phenoxazines, and organic conducting salts. The mediators are sometimes added to the sample.

- (b) Glucose oxidase and ferrocene derivatives integrated in test-strip electrodes (see \rightarrow *screen-printed electrodes*); The enzymatic oxidation of glucose is followed by the regeneration of the enzyme: $\text{enzyme-FADH}_2 + 2 \text{Fc}_{(\text{ox})} \rightarrow \text{enzyme-FAD} + 2 \text{Fc}_{(\text{red})}$ and subsequent oxidation of the ferrocenium ion $2 \text{Fc}_{(\text{red})} \rightarrow 2 \text{Fc}_{(\text{ox})} + 2 \text{e}^-$. The current

is related to the glucose concentration. This chemistry has led to mass-produced single-use glucose sensors for personal glucose measurement.

- (c) Coulometric measurement of glucose consumption with a wired quinoprotein dehydrogenase are alternatives that are almost oxygen independent. A redox hydrogel containing osmium derivatives is used together with quinoprotein glucose dehydrogenase in a small compartment of a coulometric cell. The reaction in the presence of glucose is: $\text{glucose} + \text{enzyme-PQQ} \rightarrow \text{gluconolactone} + \text{enzyme-PQQH}_2$; $\text{enzyme-PQQH}_2 + 2 \text{Os}^{3+} \rightarrow \text{enzyme-PQQ} + 2 \text{Os}^{2+}$ and at $+200$ mV $2 \text{Os}^{2+} \rightarrow 2 \text{Os}^{3+} + 2 \text{e}^-$. The current is collected and related to the glucose concentration of the sample.

Glucose sensors are mainly used to determine blood glucose in clinical chemistry and diabetes home monitoring. The detection limit is around $1 \mu\text{M}$ and increases by additional diffusion barriers for undiluted whole-blood measurement and in-vivo application. Typical response times are below one min. Screen-printed electrodes are often made for single use. Entrapment of GOD in polyurethane and amperometric indication of hydrogen peroxide may result in a massively stabilized glucose sensor which may be reused more than 1000 times.

The determination of glucose is not only a frequently performed routine analysis in clinical chemistry but also in biotechnology and food industry.

Refs.: [i] Clark LC, Lyons C (1962) *Ann NY Acad Sci* 102:29; [ii] Turner APF, Karube I, Wilson GS (1987) *Biosensors: fundamentals and applications*. Oxford University Press, Oxford; [iii] Scheller FS, Schubert F (1992) *Biosensors*. Elsevier; [iv] Heller A (1990) *Acc Chem Res* 23:128; [v] Bard AJ, Stratmann M, Wilson GS (eds) (2002) *Bioelectrochemistry*. *Encyclopedia of electrochemistry*, vol. 9. Wiley-VCH, Weinheim

UW

Glutathione — Glutathione (γ -Glutathione) is a tripeptide (γ -glutamylcysteinylglycine), with molecular mass: $M = 307.33$ g/mol, m.p. 192 – 195 °C with decomposition. Glutathione (GSH) is occurring in high concentrations in living organisms (1 – 10 mM in animals). GSH is an antioxidant and protects cells from free radicals and toxic xenobiotics (drugs, carcinogens, pollutants). GSH adsorbs on metal electrodes forming a barrier film to redox reactions of negatively charged hydrophilic redox species (e.g., $[\text{Fe}(\text{CN})_6]^{-3/-4}$), at $\text{pH} > 3$. The GSH monolayer films show interesting ion gating properties as the GSH molecules can change their conformation in

response to divalent and trivalent metal ions coordinating to carboxylic groups in GSH side chains. The conformational transition results in opening of ion channels in GSH film with diameter of 0.4 nm, allowing for a free access of redox probe ions to the electrode surface. The formation of ion channels can be used for templated metal deposition. The high conformational sensitivity to alkaline earth metals, heavy metals and, especially, to lanthanide ions has been used to design sensors for these metals, based on EQCN or capacitive response.

While the metal ions are coordinated reversibly to GSH films, the cationic drugs and neurotransmitters, such as chlorpromazine, serotonin, and dopamine bind irreversibly to GSH films, most likely due to the hydrophobic interactions.

On an Au electrode, GSH is oxidized at $E > 0.7$ V (NHE) at pH 5. The adsorbed GSH films, in the form of a gold thiolate (AuSG), are reductively desorbed at sufficiently cathodic potential, $E \approx -1.2$ V, which depends on the presence of stabilizers, such as Ni^{2+} ions, and pH.

Refs.: [i] Hepel M, Tewksbury E (2003) *J Electroanal Chem* 552:291; [ii] Hepel M, Tewksbury E (2004) *Electrochim Acta* 49:3827; [iii] Wu G, Fang YZ, Yang S, Lupton JR, Turner ND (2004) *J Nutr* 134:489

MHep

Goldschmidt tolerance factor → *perovskites*

Gokhshtein, Yakov Peysachovich



(Courtesy of A.Y. Gokhshtein)

(Sep. 23, 1906, Golendry, Russia, now Ukraine – Nov. 29, 1996, Moscow, Russia) Soviet electrochemist, graduated at Odessa Chemical Institute in 1930, where he received his Ph.D. in 1935 for work on polarography. From 1946 to 1996 he worked at the Academy of Sciences in Moscow, until 1963 at the Institute of Geochemistry and Analytical Chemistry, later at the Institute of High Temperatures. He invented in 1961 together with his son Alexander the first automatically working → *static mercury drop*

electrode [i, ii] that was manufactured in Smolensk, Russia. He has also contributed to the theory of diffusion-controlled reactions [iii].

Refs.: [i] Gokhshtein YP, Gokhshtein AY (1962) *Zh fiz khim* 36:651; [ii] Gokhshtein YP (1964) *Oscillographic polarography of the interrupted mercury electrode and the accumulation effect*. In: Hills GJ (ed) *Polarography. Proceedings of the third international congress, Southampton*, vol. 1. Macmillan, London, pp 215–219; [iii] Gokhshtein AY, Gokhshtein YP (1960) *Dokl Akad Nauk SSSR* 131:601

FS

Gold → *electrode materials*

Goodness-of-fit — (R^2) A dimensionless number that varies between 0.0 and 1.0 from which the higher values indicate that the model fits the data better. Thus, R^2 would be equal to 1.0 if all calculated points lie exactly on the experimental curve with no scatter. By tradition, uppercase (R^2) is used for the results of non-linear and multiple regressions, while lowercase (r^2) is employed for the results of linear regression. It is computed from the sum of the squares of the → *residuals* divided by the sum of the squares of the difference between every data point of the dependent variable ‘ y_i ’ and their → *mean*. Thus, the value of R^2 is calculated as [i]:

$$R^2 = 1.0 - \sqrt{\frac{\sum_{i=1}^n (y_i - f(x_i))^2}{\sum_{i=1}^n (y_i - \bar{y})^2}}$$

Ref.: [i] Ryan TP (1997) *Modern regression methods*. Wiley Interscience, New York

FG

Gouy–Chapman capacity → *double layer*, → *Parsons and Zobel Plot*

Gouy, Louis Georges



(Courtesy of “The International Solvay Institutes, Brussels”)

(Feb. 19, 1854, Vals-des-Bains, Ardèche, France – Jan. 27, 1926, Vals, Ardèche, France) Gouy was a professor at the Université de Lyon [i–iii] and is most remembered in electrochemistry for the theory of the diffuse electrical

→ *double layer* [iv, v]. He reported the equations based on his double-layer model for 1:1 electrolytes [iv], and in a related full paper for asymmetrical electrolytes [v]. He published several papers also on the → *electrocapillary* phenomenon [vi]. His famous work on Brownian motion [iv] was cited by → *Einstein* [vii]. He worked on optical interference and magnetic effects (the Gouy balance is named after him). In some books and papers his name cited erroneously as M. Gouy because many of Gouy's papers refer to him as M. Gouy, however, M. denotes monsieur! Gouy became a corresponding member (1901) and a member (1913) of the French Academy of Sciences.

Refs.: [i] Laidler KJ (1993) *The world of physical chemistry*. Oxford Univ Press, Oxford; [ii] de Levie R (2000) *J Chem Educ* 77:5; [iii] Dunsch L (1985) *Geschichte der Elektrochemie*. VEB Deutscher Verlag f Grundstoffindustrie, Leipzig; [iv] Gouy G (1909) *CR Acad Sci* 149:654; [v] Gouy G (1910) *Sur la constitution de la charge électrique à la surface d'un électrolyte* (On the constitution of the electric charge on the surface of an electrolyte). *J phys* 9(4):457; [vi] Gouy G (1903) *Sur la fonction électrocapillaire I–III*. *Ann Chim Phys* 29(7):145; *ibid* (1906) 8 (18):291; [vii] Einstein A (1905) *Ann Phys* (IV) 19:371

GI

Gouy–Chapman layer → *double layer*

Gouy–Chapman theory → *double layer*

Gouy length — The width of the → *diffuse double layer* at an electrode depends on a number of factors among which the charge density q on the surface of the metal and the concentration c of electrolyte in the solution are paramount. Roughly speaking, the charge in, and the potential of, the double layer falls off exponentially as one proceeds into the solution from the interface.

The characteristic length associated with this exponential fall-off is the Gouy length. According to the Gouy–Chapman model, this length is $\beta \operatorname{arsinh} \sqrt{8RT\epsilon c/q}$, where ϵ and T are the permittivity and temperature of the medium, R being the gas constant. The quantity β , equal to $\sqrt{RT\epsilon/2z^2F^2c}$, is the → *Debye length*. The Debye length and the Gouy length have much in common because the diffuse double layer adjacent to an electrode and the “ionic cloud” around a single ion arise from similar causes.

See also → *Gouy*.

Refs.: [i] Oldham KB, Myland JC (1993) *Fundamentals of electrochemical science*. Academic Press, San Diego, section 9.2; [ii] Bard AJ, Faulkner LR (2001) *Electrochemical methods*, 2nd edn. Wiley, New York, Chap. 13

KBO

Graded potential — is a wave of electrical excitation that appears as a result of short-lived depolarization or hyperpolarization of an area of the plasma membrane in neurons or conductive bundles of plants. This phenomenon causes local flows of electrical current that decrease with distance. The magnitude of a graded potential depends on the intensity or strength of the stimulus. The more intense is the stimulus, the more ion channels are opened, and the voltage change is greater. Many neurons and plant conductive bundles use graded potentials to transmit information. Graded potentials are used by dendrites for returning signals from sensory organs. Graded potentials get weaker as they travel along nerve fibers or conductive bundles in plants, whereas → *action potentials* remain the same strength as they travel. Graded potentials are additive, or undergo summation.

Ref.: [i] Volkov AG (ed) (2006) *Plant electrophysiology*. Springer, Berlin

AV

Graham, Thomas



(Dec. 21, 1805, Glasgow, Scotland, UK – Sep. 16, 1869, London, UK) Graham studied at the Universities of Glasgow and Edinburgh. In 1830 he became Professor of Chemistry at the Andersonian University, Glasgow, and in 1837 he was appointed at London University (now University College, London) where he served until 1855, when he succeeded Sir John Herschel as Master of the Mint. Among his many contributions to science [i, ii] are the discovery that phosphoric acid is a triple-basic acid, the discovery of laws of gas → *diffusion* and effusion, and the discovery of dialysis. Graham coined the term → *colloid* and is regarded as one of the fathers of colloid chemistry.

Refs.: [i] Williamson AW (1869) *Nature* 1:20; [ii] Kauffman GB (2005) *Chem Educator* 10:457

FS

Grain boundaries — are the → *interfaces* between crystals or individual grains in polycrystalline solid materials. In a simplest case, the grain boundary separates

two crystallites, each having the same structure as a single crystal of given composition. When the difference in orientation of these crystallites is moderate, the interface can be considered as a dislocation network (see also → *Burger's vector* and → *defects in solids*). In realistic systems, the grains are often separated by a thin amorphous layer, which may also comprise inclusions of secondary phases.

The zone near grain boundaries is usually a highly defective, → *space charge region*. As a result, the boundaries may have a significant effect on the transport and electrochemical properties, especially for → *ionic conductors*. Due to a high interfacial energy (→ *interfacial tension*) and relatively weak bonding compared to the crystallite bulk, grain boundaries are the preferred sites for segregation of new phases, including a liquid phase nucleation on heating, for the → *corrosion* onset, and for the defects formation and annihilation. See also → *surface*.

In common cases, the grain-boundary thickness is close to a few nanometers; the overall volume fraction of the boundaries is very small. The opposite situation is observed in nanocrystalline solids, with profound effects on defect → *thermodynamics* and transport.

Refs.: [i] Chiang YM, Birnie DP, Kingery WD (1997) *Physical ceramics: principles for ceramic science and engineering*. Wiley, New York; [ii] Sutton AP, Balluffi (1995) *Interfaces in crystalline materials*. Oxford Sc Publ, Oxford

VK

Grain refiners → *electroplating additives*

Granfeld cell — This was a variant of the → *Daniell cell*.

See also → *zinc*, → *Zn²⁺/Zn electrodes*, → *Zn²⁺/Zn(Hg) electrodes*, → *zinc-air batteries (cell)*, and → *Leclanché cell*.

Ref.: [i] Hauck WP (1883) *Die Galvanischen Batterien, Accumulatoren und Thermosäulen*, 2nd edn. Hartleben's Verlag Wien

FS

Graphite electrode — Graphite is the thermodynamically stable form of → *carbon* under standard conditions [i]. Graphite has a gray metallic appearance, a density of 2.26 g cm⁻³, and an atomic structure composed of grapheme sheets, a two-dimensional honey comb structures of carbon atoms (sp²) where each atom has three nearest neighbors in 1.42 Å distance (compare to curved structures → *fullerenes* and → *carbon nanotubes*). In graphite these sheets (“graphene sheet”) are stacked with a regular interlayer spacing of 3.35 Å.

The structure of graphite allows electrons to move fast within graphene sheets (specific conductivity parallel to

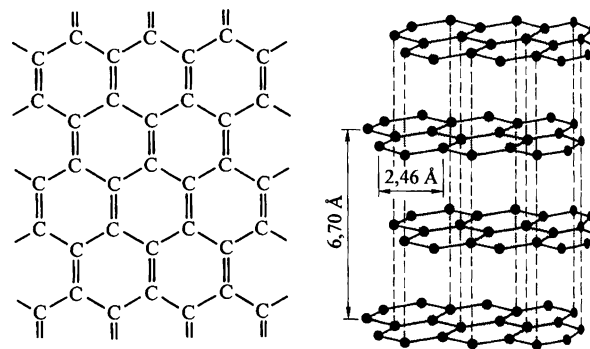

Graphite electrode — Figure

layers $2.6 \times 10^4 \Omega^{-1} \text{cm}^{-1}$, negative temperature coefficient like a metal) and relatively slow perpendicular to the graphene sheets (specific conductivity four orders of magnitude lower, positive temperature coefficient). The properties of carbon materials strongly depend on the crystalline order in graphitic regions.

Graphite is widely employed as electrode material. A range of synthetic graphite materials have been developed by high temperature treatment of coke (→ *Acheson process*, → *Acheson® graphite*), by high temperature carbonization of precursor polymers (→ *carbon fiber electrodes*, → *carbon felt electrodes*, carbon foams or aerogels, and → *glassy carbon electrodes*), by carbonizing organic materials (activated carbons), by burning petroleum with limited air supply (soot, carbon black), and by burning methane, natural gas (thermal blacks) or acetylene (acetylene black). The blacks as seen under the electron microscope consist of aggregates of 5–100 nm diameter particles with extremely high surface areas of up to 1000 m² g⁻¹. Many of these graphite materials have been employed as electrodes in pure form or as a composite. Important modified graphite materials are intercalated graphite (with species such as fluorine, sulfate, lithium, potassium, etc. inserted into the interlayer spaces, → *intercalation electrodes*), exfoliated or expanded graphites (with graphene sheets separated and reoriented).

Highly oriented pyrolytic graphite (HOPG) is commercially produced by high temperature deposition of carbon at ceramic surfaces and graphitization at 3000 °C [ii]. Highly oriented pyrolytic graphite is employed as edge plane pyrolytic graphite electrode (EPPG, graphene sheets perpendicular to the electrode surface) or as basal plane pyrolytic graphite electrode (BPPG, graphene sheet parallel to the electrode surface). The properties of these electrodes are very different due

to the different abilities of electrons to transfer from the graphene edges or perpendicular to the graphite plane [iii]. EPPG is often observed to behave electrocatalytically [iv] and has been successfully employed for processes involving immobilized redox proteins [v].

Graphite composite electrodes are obtained by incorporation of graphite flakes (or similar pure graphitic materials) into inert host materials. The → *carbon paste electrode* is obtained from graphite flakes and mineral oil. The → *paraffin impregnated graphite electrode* (PIGE) is based on a graphitic host impregnated with high melting paraffin. “Pencil lead” as a graphite–ceramic composite has been employed as electrode and carbon–epoxy composites are commonly prepared with functional additives for specific sensor applications.

Refs.: [i] Holleman AE, Wiberg N (1995) *Inorganic chemistry*. Academic Press, London; [ii] Pierson HO (1993) *Handbook of carbon, graphite, diamond and fullerenes*. Noyes Publications, New Jersey; [iii] McCreery RL (1991) *Carbon electrodes: structural effects on electron transfer kinetics*. In: Bard AJ (ed) *Electroanalytical chemistry*, vol. 17. Marcel Dekker, New York; [iv] Banks CE, Compton RG (2005) *Anal Sci* 21:1263; [v] Conrad LS, Hill HAO, Hunt NI, Ulstrup J (1994) *J Electroanal Chem* 364:17

FM

Graphite felt electrode → *carbon electrode*, subentry → *carbon felt electrode*

Grashof number — The Grashof number (*Ge*) is a dimensionless parameter that relates the ratio of buoyancy forces to the viscous forces with a fluid solution. It is defined as:

$$Ge = gL^3 \beta (T_s - T_\infty) / \nu^2,$$

where *L* is the characteristic dimension, β is the volumetric coefficient of thermal expansion of fluid, ν is the kinematic → *viscosity*, *g* the acceleration due to gravity, *T_s* the source temperature, *T_∞* the bulk temperature. The product of the Grashof number and the Prandtl number gives the Rayleigh number, a dimensionless parameter that characterizes convection problems in heat transfer.

Ref.: [i] Wragg AA (2001) *J Heat Transfer* 21:1047

AF

Grätzel cells → *dye cells*

Gravimetric analysis — A quantitative chemical analysis in which the → *analyte* and a specific reagent react to give a slightly soluble product that can be separated, dried, and weighed. Alternatively a solid compound can also be weighed before and after volatilization of some

volatile component with the difference in mass representing the amount of such volatile species [i]. When the precipitate is produced by an electrochemical reaction, the technique is called → *electrogravimetry*.

Ref.: [i] Harris D (2002) *Quantitative chemical analysis*. WH Freeman, New York

FG

Gravimetric energy density → *energy density*

Gravimetric titrimetry — A → *titration* method in which the mass of → *titrant* that is added to the → *titrand* is weighted by using a balance [i].

Ref.: [i] Harris D (2002) *Quantitative chemical analysis*. WH Freeman, New York

FG

Gravimetry → *gravimetric analysis*

Gray, Stephen — (b. 1666 Canterbury, England – Feb. 15, 1736 London, England) Stephen Gray was baptised in Canterbury, Kent, England on 26 December 1666 (St Stephen’s day – hence possibly his name). Little is known about his education, though like Shakespeare he probably acquired rudimentary Latin at school. He first came to the attention of the Royal Society in 1696, when he published the design of a novel magnifying lens. This greatly interested the Astronomer Royal, John Flamsteed, and the two soon became firm friends. For a decade afterwards Gray applied his energies to the quantitative observations of astronomical phenomena such as sunspots and solar eclipses, but after 1706 his astronomical work petered out as he became increasingly troubled by an arthritic hip. He then found it difficult to earn a living, a problem exacerbated by his natural shyness [i]. Fortunately, he was rescued by the good offices of Flamsteed and Sir Hans Sloane (later President of the Royal Society), who arranged for him to be admitted as a Poor Brother into the Charterhouse (a well-endowed almshouse for “gentlemen by descent and in poverty”) in Clerkenwell, London, in 1718. It was at this point that Gray began his epochal experiments on electricity, sometimes carried out at friend’s houses. In 1732 (at the age of sixty five!) Gray announced the discovery of electrical conduction in the following words [ii];

“Sir, in the Year 1729 I communicated to Dr. Desaguliers [iii], and some other Gentlemen, a Discovery I had then made, showing that the Electric Virtue of a Glass Tube may be conveyed to other Bodies so as to give them the same Property of attracting and repelling Light Bodies as the Tube does, when excited by rubbing; and that

this attractive Virtue might be carried to Bodies that were many Feet distant from the Tube...” [iv].

No other method of electrification (other than by friction) had previously been known. After Hans Sloane had taken over the Presidency of the Royal Society in 1727, Gray belatedly began to receive the recognition that his electrical research deserved. He was awarded the Royal Society’s first Copley Medal in 1731 for his discovery of conduction, and the second in 1732 for his work on electrostatic induction. Despite his electrical experiments, and a fondness for tobacco, he survived until 1736. He has no monument in stone, but is memorialized in verse by “Dictionary Johnson” (Samuel Johnson 1709–1784) [v]. He received the Copley Medal twice (in 1731 and 1732) and became FRS in 1733.

Refs.: [i] *An observation of Brook Taylor (originator of Taylor’s theorem) in a letter to John Keill, 03 July 1713.* [ii] *“Two letters from Gray to Mortimer, containing a farther account of his experiments concerning electricity”, Philosophical Transactions No 37 (1731–32).* [iii] *Jean Théophile (John Theophilus) Désaguliers (12 March 1683–29 February 1744) was a brilliant instrument designer, the French-born son of a Huguenot who fled to England some time after the revocation of the Edict of Nantes in 1685.* [iv] *“Attractive virtue” may be interpreted as “electrostatic potential”. Note that I have modernized the spelling, but not the punctuation!* [v] *“On the Death of Stephen Grey (sic), FRS” in “Miscellanies in Prose and Verse”, ostensibly by Mrs. Anna Williams, but actually by Samuel Johnson, as described in Boswell’s “Life of Johnson”, ed Hill GB and Powell LF, Oxford, Clarendon Press, 1934*

SF

Grazing angle optical cell — An optical cell for the spectroscopic analysis of thin layers adsorbed on reflective surfaces, commonly used for IR spectroscopy. The optical setup in reflectance mode guides the incident IR beam to the reflective surface at a grazing angle that is usually defined as an angle higher than 75° (see figure below). The best results are usually obtained by using an incident angle at $80\text{--}85^\circ$. These incident angles are used in order to enhance the spectral sensitivity to the surface species, which are usually adsorbed with their dipole moment perpendicular to the surface. The enhancement is firstly due to the enlargement of the op-

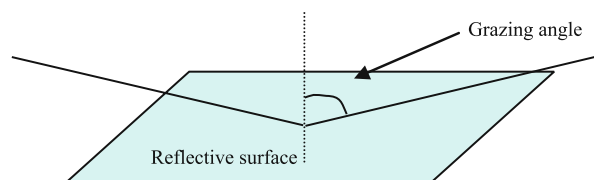

Grazing angle optical cell — Figure

tical way of the IR beam through the adsorbed film. The length of the sample that is actually analyzed by the IR beam in reflectance mode is equal to $l/\cos\theta$ (l is the film’s thickness and θ is the incident angle). Therefore, increasing the angle of the incidence enlarges the sample length that interacts with the IR beam, and thus improves the SNR (\rightarrow *signal-to-noise ratio*) of the obtained spectra and increases the sensitivity of the measurements. Such a configuration is normally used for sub-micrometric thick film analysis. In addition, polarized light can be used for the further enhancement of the spectral features measured from the surface. The P-polarized component of the light is well absorbed by adsorbed species whose dipole moment is perpendicular to the surface, which enhances the signal that interacted with the surface species. The s-polarized component has a node on the surface due to destructive interference, and therefore does not contribute to the signal measured from the surface. Hence, the use of p-polarized light at a grazing angle reflectance mode contributes to the further enhancement to the sensitivity of the spectra measured from adsorbed surface species. The spectra obtained under these conditions are not pure absorbance spectra, and occasionally the peaks are shifted to the blue. In addition, since the peak intensity depends on the angle of incident and on the light polarization state, quantitative work based on Beer’s law can be misleading. Grazing angles are also used in XRD measurements for enhancement sensitivity to surface species.

Refs.: [i] Nishikida K (1996) *Selected applications of modern FT-IR techniques*. Taylor & Francis, London, pp 46–57; [ii] Humecki HJ (1995) *Practical guide to infrared microspectroscopy*. Marcel Dekker, New York, pp 41–85; [iii] Rubinstein I (1995) *Physical electrochemistry*. Marcel Dekker, New York, pp 354–355

OC, DA

Grenet–Jarriant pile — This was a \rightarrow *battery* consisting of 48 chromic acid (carbon electrode) – zinc cells.

See also \rightarrow *chromic acid battery*, \rightarrow *Daniell cell*, \rightarrow *zinc*, \rightarrow *Zn²⁺/Zn electrodes*, \rightarrow *Zn²⁺/Zn(Hg) electrodes*, \rightarrow *zinc–air batteries (cell)*, and \rightarrow *Leclanché cell*.

Ref.: [i] Hauck WP (1883) *Die Galvanischen Batterien, Accumulatoren und Thermosäulen*, 2nd edn. Hartleben’s Verlag, Wien

FS

Griscom battery — This was a chromic acid (carbon electrode) – zinc \rightarrow *battery* with a mechanism to control the depth of immersion of the electrodes in the electrolyte. The latter was attempted to regulate the current for sewing machines.

See also → *chromic acid battery*, → *Daniell cell*, → *zinc*, → Zn^{2+}/Zn electrodes, → $Zn^{2+}/Zn(Hg)$ electrodes, → *zinc-air batteries (cell)*, and → *Leclanché cell*.

Ref.: [i] Hauck WP (1883) *Die Galvanischen Batterien, Accumulatoren und Thermosäulen*, 2nd edn. Hartleben's Verlag, Wien

FS

G

Grounding (of instruments) — The shielding of electrical cables employed in connections between measuring instruments (including, e.g., → *potentiostats*) has to be connected to a point called “ground” or “system ground”. In many cases this may be the external metal case of the main measuring instrument, which in turn is connected to true ground of the electrical power supply line by means of a grounding wire. Care must be exercised when connecting shields of wires between various instruments. They should be connected all to one single common point in order to avoid “ground loops” which might induce noise signals. See also → *earthing*.

RH

Grove, William Robert

(July 11, 1811, Swansea, Wales, UK – Aug. 1, 1896, London, UK) Grove was educated at the Branos College, Oxford. He was a successful lawyer and judge but besides carried out scientific work and was professor of experimental philosophy at the London Institution from 1841 to 1846. He was one of the founders of the Chemical Society (London, 1841) and served as a secretary of the Royal Society from 1847 to 1849. His book “On the Correlation of Physical Forces” (1846) was an important contribution to the law of conservation of energy [i]. Grove invented two cells of special significance. His first cell consisted of zinc in dilute sulfuric acid and platinum in concentrated nitric acid, separated by a porous pot [ii]. It was used by → *Faraday* in his demonstration at the Royal Institution, and was a favorite battery of the early American telegraph (1840–1860), because it offered strong current output and an → *electromotive force* of 1.8–2.0 V. As the

telegraph traffic increased the Grove cell was replaced because it discharged poisonous nitric dioxide gas.

His second cell called “gas voltaic battery” consisted of platinum electrodes immersed in acid solution, with hydrogen over one electrode and oxygen over the other [iii–v]. It was the forerunner of the modern → *fuel cells*.

Refs.: [i] Laidler KJ (1995) *The world of physical chemistry*. Oxford University Press, Oxford, pp 219, 432; [ii] Grove WR (1839) *Philos Mag* 20:249; [iii] Grove WR (1839) *Philos Mag* 14:127; [iv] Grove WR (1842) *Philos Mag* 21:417; [v] Grove WR (1843) *Proc R Soc* 4:463

GI

Grove cell → *Grove*

Grotthuss, Christian Johann Dietrich (later Theodor)

(Jan. 20, 1785, Geddutz, Kurland, now Gedučiai, Lithuania – Mar. 26, 1822, Geddutz, Kurland, now Gedučiai, Lithuania) The Lithuanian natural scientist Grotthuss studied chemistry at the University of Leipzig in 1803; 1805 publication on theory of electrolysis of aqueous solutions describing for the first time the polarization of water molecules and the hopping mechanism of electrolytic conductivity [i]; 1807 member of Société Galvanique in Paris. He investigated various other scientific subjects [ii], especially in photochemistry. In 1809 he discovered that for photochemical action the light must be absorbed; this was rediscovered by Draper in 1841 and is known as the Grotthuss–Draper law. (See also → *Grotthuss mechanism*).

Refs.: [i] Grotthuss T (1805) *Mémoire sur la décomposition de l'eau et des corps, qu'elle tient en dissolution à l'aide de l'électricité galvanique*, Rome, 1805. (*Philos Mag* (1806) 25:330); [ii] Laidler KJ (1995) *The world of physical chemistry*. Oxford University Press, Oxford

RH

Grotthuss mechanism — Classical mechanism proposed by → *Grotthuss* [i] to explain the transport of elec-

tricity in solutions. He had noticed that in a row of marbles in contact, the collision of the marble at one end of the row with a new marble caused a marble at the far end to detach itself and go off alone. This sort of movement would provide a rapid way for a proton to travel through a solution. When a proton arrives at one water molecule, making it temporarily a hydronium ion (H_3O^+), another different proton from the same H_3O^+ detaches itself from the H_3O^+ for the next hop. This proton jump mechanism, the so-called Grotthuss mechanism, provides the abnormally high conductivity of protons in water. A similar mechanism is applied to explain the higher conductivity for OH^- . However, the actual mechanism is still highly contentious [ii–v]. Attention now focuses on the H_9O_6^+ unit, in which a H_3O^+ ion is associated with three strongly solvating H_2O molecules [iv, v]. It is envisaged that the rate-determining step of the proton transfer is the cleavage of a weaker hydrogen bond, not in the first solvation shell, but in the second solvation shell. (See also \rightarrow *prototropic charge transfer*).

Refs.: [i] von Grotthuss CJD (1806) *Ann Chim LVIII*:54; [ii] Bockris JOM, Reddy AKN (1998) *Modern electrochemistry*, vol. 1, 2nd edn. Wiley, New York; [iii] Atkins P, de Paula J (2002) *Physical chemistry*, 7th edn. Oxford University Press, Oxford; [iv] Agmon N (1995) *Chem Phys Lett* 244:456; [v] Marx D, Tuckerman ME, Hutter J, Parrinello M (1999) *Nature* 397:601

TO

Guest — An organic or inorganic ion or molecule that occupies a cavity, cleft, or pocket within the molecular structure of a host and forms an inclusion complex (\rightarrow *inclusion compound*) with it or that is trapped in a cavity within the crystal structure of a host.

Ref.: [i] Muller P (1994) *Pure Appl Chem* 66:1077

Gurney, Ronald Wilfrid



(Photo © Cambridge University (with permission))

(July 01, 1898, Cheltenham, Gloucestershire, England – Apr. 15, 1953, New York, USA). Gurney entered Chel-

tenham College in Sep. 1911 and left in Apr. 1917. He was commissioned “ensign” (2nd Lieutenant) in the 4th (City of Bristol) Battalion, The Gloucester Regiment on 3rd Feb. 1919, but by Oct. 1919 he had entered Trinity Hall, Cambridge, where he graduated BA in June 1922. This was followed by doctoral studies under Ernest Rutherford at the Cavendish Labs, which led to MA and Ph.D. degrees in June 1926. Thereafter, he accepted a Visiting Fellowship at Princeton University (1926–27) that was extended into 1928 thanks to the award of a Charlotte Elizabeth Proctor Fellowship. It was during 1928 that he met Edward Uhler Condon (1902–1974). Famously, the pair published the first paper on the application of the “new” quantum mechanics to radioactive decay [i]. As recounted by Condon [ii], it was Gurney who had the key idea that the emission of alpha particles from radioactive elements could take place by “barrier penetration” (today known as \rightarrow *tunneling*). Within a year, Gurney had also explained how the rate of barrier penetration could be massively enhanced if the penetrating particle had the same energy on both sides of the barrier (resonance tunneling) [iii]. This was three years before the Cockcroft–Walton experiments established that resonance tunneling could cause the artificial transmutation of chemical elements [iv]. After these early successes, it was only a matter of time before Gurney would apply his concept of resonance tunneling to electron transfer, and this duly took place back at the Cavendish Labs in 1931. Based on some experimental data of the Australian scientist Frank Philip Bowden (1903–1968), Gurney wrote the most important electrochemistry paper since \rightarrow *Tafel* [v]. In the paper [vi] Gurney assembled many of the key ideas of modern \rightarrow *electron transfer* theory. In particular, he noted that electrons in electrodes occupy a distribution of states according to \rightarrow *Fermi–Dirac statistics*; he noted that ions in solution occupy an electron transfer distribution of states due to their differing degrees of \rightarrow *solvation*; and he noted that electron transfer must take place preferentially between states having the same energy. He further noted that the effect of the electrode potential was to decrease the \rightarrow *electron work function* of the metal; he noted that the elementary act of electron transfer must take place so quickly that nuclei are effectively stationary (“as in the Franck–Condon principle”); and he pointed out that an essential condition for large current flow was that there must be a large overlap between the ionic and metallic orbitals. Finally, he showed that the mathematical formulation of electron transfer theory necessarily involves summations over joint dis-

tributions of ionic and electronic states. The only major feature that he was not able to explain was how the conservation of energy and the Franck–Condon principle could be satisfied simultaneously. That particular conundrum was finally solved by → *Randles* in 1952 [vii]. In a final flourish to his career [viii], Gurney pointed out that the chemical potentials of non-electrolytes in various solvents should be based on their concentrations expressed as mole fractions x_k (amount fractions) rather than molalities. (The advantage of doing this is that the unit of mole fraction corresponds to 100% purity of one component, which eliminates complications from the entropy of mixing. This has

proved to be very important in the study of hydrophobicity.)

Gurney married Natalie Kouteinikoff on 31st Aug. 1934, moved to the United States in 1941, and died in New York City in 1953.

Refs.: [i] Gurney RW, Condon EU (1928) *Nature (Lond)* 122:439; [ii] Condon EU (1969) reprinted (1978) *Am J Phys* 46:319; [iii] Gurney RW (1929) *Nature (Lond)* 123:565; [iv] Cockcroft JD, Walton ETS (1932) *Nature (Lond)* 129:649; [v] Tafel J (1905) *Z Phys Chem* 50:641; [vi] Gurney RW (1931) *Proc Roy Soc (Lond)* 134:137; [vii] Randles JEB (1952) *Trans Faraday Soc* 48:828; [viii] Gurney RW (1953) *Ionic processes in solution*, McGraw-Hill, New York

SF

H

H-cell — is a divided electrochemical cell, named after its similarity with letter H. It principally consists of two compartments, connected through a diaphragm. A modification or special H-type design is the → *Lingane* cell [i], developed for use with mercury electrodes within a three-electrode setup. Glass H-cells are commercially available, but may nevertheless be easily constructed in a laboratory, as shown in the figure [ii].

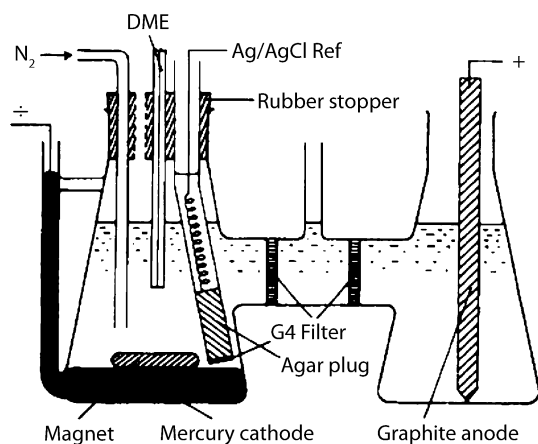

H-cell — Figure

With minor modifications, the setup can also be used with a solid working electrode, or for nonaqueous electrolyte solutions. H-cells with solid plane parallel electrodes of the same area are frequently utilized for work in anhydrous media, also since they provide a uniform current distribution. A small distance between the electrodes, not only for this cell design, makes them suitable for work in media of low electrical conductivity. The cell design can be used for electrolysis in liquid ammonia, if a connection between the anode and cathode compartment above the solution level is ensured, to equilibrate the pressure in the system [iii].

Refs.: [i] Lingane JJ, Gardner Swain C, Fields M (1943) *J Am Chem Soc* 65:1348; [ii] Lund H (2001) *Practical problems in electrolysis*. In: Lund H,

Hammerich O (eds) *Organic electrochemistry*, 4th edn. Marcel Dekker, New York, pp 223–292; [iii] Smith WH, Bard AJ (1975) *J Am Chem Soc* 97:5203

MHer

Haber, Fritz



(© The Nobel Foundation)

(Dec. 9, 1868, Breslau, Silesia, Germany, now Wrocław, Poland – Jan. 29, 1934, Basel, Switzerland). Haber has controversial fame: he is primarily known for the development of a method of synthesizing ammonia (Nobel Prize in Chemistry, 1918) [i–iii] and for the development of poisoning gas used in the World War I [iv]. He worked successfully in many different areas of chemistry and chemical technology. Even his failure at obtaining gold from seawater actually paved the way for the extraction of bromine from the ocean. In electrochemistry, he studied the nature of the quinone-hydroquinone redox system, devised a → *glass electrode* to measure hydrogen ion concentration by means of the electric potential (pH-electrode) (together with → *Klemensiewicz*) [v] and designed → *fuel cells*. Haber published a book on the theoretical basis of technical electrochemistry [vi].

See also → *Beutner*, and → *Luggin*.

Refs.: [i] Farber E (1961) *Great chemists*. Interscience Publishers, New York; [ii] Goran M (1967) *The story of Fritz Haber*. University of Oklahoma Press, Norman; [iii] McBryde WAE (1993) In: James LK (ed) *Nobel laureates in chemistry 1901–1992*. American Chemical Society, New York, pp 114–123; [iv] Haber LF (1986) *The poison cloud*. Clarendon Press, Oxford; [v] Haber F, Klemensiewicz Z (1909) *Z phys Chem* 67:385; [vi] Haber F (1898) *Grundriss der Technischen Elektrochemie auf theoretischer Grundlage*. Oldenbourg, München

EK

Hackerman, Norman



H

(Mar. 2, 1912, Baltimore, Maryland, USA, – June 16, 2007, Austin, Texas, USA), Hackerman received both his baccalaureate (1932) and doctoral (1935) degrees in chemistry at Johns Hopkins University. He held assistant professorships at Loyola College in Maryland (1935–39) and at the Virginia Polytechnic Institute (1941–43), as well as positions with Colloid Corporation and Kellogg Corporation. During the period of World War II, he also served with the U.S. Coast Guard and the Manhattan Project. In 1945 he moved to Texas to accept a teaching position at The University of Texas in Austin (UT) and remained in Texas for the rest of his life.

Hackerman quickly rose through the academic ranks at UT and served as chairman of the chemistry department (1952–62), dean of research and sponsored programs (1961–62), vice president and provost (1962), vice chancellor of academic affairs (1963–67), and university president (1967–70). In 1970, he joined the faculty of Rice University as a professor of chemistry and president of the university, holding both appointments until his retirement in 1985. Beginning in 1982 and continuing until 2005 Hackerman chaired the Scientific Advisory Board of the Robert A. Welch Foundation, which had a large impact on fundamental chemical research in the state of Texas.

Hackerman was a leader in the field of \rightarrow corrosion, \rightarrow passivity, and surface chemistry at electrodes and metals. He was especially active in the field of \rightarrow corrosion inhibitors and establishing a molecular basis for their action. Hackerman promoted science at the federal and state levels through many activities, such as the National Science Board (1968–80; chair 1975–80). He was also active in the Electrochemical Society, serving as president (1957–58) and editor of the Journal of the Electrochemical Society (1969–89). He was elected to membership in a number of societies, including the National Academy of Sciences (1971), the American Philosophi-

cal Society (1972), and the American Academy of Arts and Sciences (1978). He received numerous awards, including the Palladium Medal from the Electrochemical Society in 1965, the Gold Medal of the American Institute of Chemists in 1978, the Charles Lathrop Parsons Award from the American Chemical Society in 1987, and the National Medal of Science in 1993.

He remained active, as a professor *emeritus* from both UT and Rice, in both teaching and research activities until his death.

Ref.: [i] Uhlig HH (1966) *J Electrochem Soc* 113:9C

AJB

Hägg diagram \rightarrow log *c*–*pH* diagrams

Hagen–Poiseuille equation — predicts the laminar flow of an incompressible and uniform viscous liquid (Newtonian fluid) through a cylindrical pipe of constant cross-section. The rate of movement of a liquid volume *V*, during a time *t*, may be predicted using:

$$\frac{dV}{dt} = \frac{\pi r^4 \Delta p}{8\eta l},$$

where *r* is the internal radius of the tube, Δp the pressure drop, η the dynamic fluid \rightarrow viscosity, and *l* the characteristic length along the pipe. Tubular flow cell geometries have been used under Hagen–Poiseuille flow conditions for voltammetric and in-situ electrochemical electron spin resonance studies [i].

Ref.: [i] Albery WJ, Compton RG, Chadwick AT, Coles BA, Lenkait JA (1980) *J Chem Soc Faraday Trans 1* 76:1391

AF

Half-crystal position (kink position) — The term was introduced into the theory of crystal growth simultaneously and independently by W. Kossel [i] and \rightarrow Stranski [ii, iii], who were the first to realize the necessity of a close consideration of the elementary acts of attachment and detachment of single particles (atoms, ions, or molecules) to and from a crystal surface.

An atom in the half-crystal position (also called kink position) (Fig. 1), is bonded (i) with a semi-infinite crystal block, (ii) with a semi-infinite crystal lattice plane, and (iii) with a semi-infinite crystal row. Attaching or detaching one atom to and from the half-crystal position a new half-crystal position is created and this is what makes this position a repeatable step in the successive building or disintegration of the bulk crystals.

Refs.: [i] Kossel W (1927) *Nachr Ges Wiss Göttingen, Math-physik Klasse, Band 135*; [ii] Stranski IN (1927) *Ann Univ Sofia* 24:297; [iii] Stranski IN (1928) *Z phys Chem* 136:259

AM

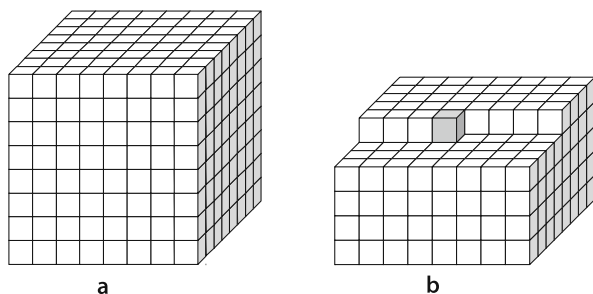

Half-crystal position (kink position) — **Figure.** The Kossel's cubic crystal (a) and the atom in the half-crystal position (b)

Half-cell — Consists of at least an electronic and an ionic conductor in close contact. It is one half of a → *galvanic cell*. Frequently it is also called an → *electrode*.

Refs.: [i] Bagotsky VS (2005) *Fundamentals of electrochemistry, part 1: Basic concepts*, 2nd edn. Wiley, New York; [ii] Brett CMA, Oliveira Brett AM (1993) *Electrochemistry*. Oxford University Press, Oxford

MD

Half-cell reaction — The → *redox reaction* (→ *electrode reaction*) proceeding in a → *half-cell*. The half-cell reaction changes the ratio of the → *activities* of the reduced and oxidized forms. When the half-cell reaction is electrochemically reversible (see → *reversibility*), the → *Nernst equation* will describe the dependence of the → *electrode potential* on the ratio of the activities of the reduced and oxidized forms.

Refs.: [i] Bagotsky VS (2005) *Fundamentals of electrochemistry, part 1: Basic concepts*, 2nd edn. Wiley, New York; [ii] Brett CMA, Oliveira Brett AM (1993) *Electrochemistry*. Oxford University Press, Oxford; [iii] Bard AJ, Faulkner LR (2001) *Electrochemical methods*, 2nd edn. Wiley, New York, p 2

MD

Half-life, $t_{1/2}$ (s) — In a kinetic experiment, the time required for the concentration of a particular reacting species to fall to one-half of its initial value. Its dependence on initial concentration depends upon the reaction order. It is independent of initial concentration only for a first-order process.

Ref.: [i] Muller P (1994) *Pure Appl Chem* 66:1077

WK

Half-peak-width — Also known as full-width-half-maximum (fwhm), peak width at half-height, $W_{1/2}$: When any experimental technique produces a peak that rises from and falls back to approximately the same base line, that peak may be characterized by its width at half the full height. In electrochemistry, the requisite peaks can be produced by → *cyclic voltammetry*

(DC) of a surface-confined redox process – at 298.2 K the half-peak-width for a reversible process is $90.6/n$ in mV where n is the number of exchanged electrons if there are no interactions between the adsorbed species (sites). In the case of attractive interactions $W_{1/2}$ is smaller, while at repulsive interactions its value is higher than 90.6 mV [i]. Peaks are also produced by AC and → *square-wave voltammetry* of solution-based as well as surface-confined redox species, and by → *stripping analysis* and other techniques [i–iii].

Refs.: [i] Bard AJ, Faulkner LR (2001) *Electrochemical methods*, 2nd edn. Wiley, New York, p 591; [ii] Bond AM (2002) *Broadening electrochemical horizons*. Oxford University Press, Oxford, pp 135, 137, 293, 295, 341, 420; [iii] Bond AM (1980) *Modern polarographic methods in analytical chemistry*. Marcel Dekker, New York, p 301

AMB

Half-wave potential → *potential*

Hall, Charles Martin



(Dec. 6, 1863, Thompson, Ohio, USA – Dec. 27, 1914, Daytona Beach, Florida, USA) Hall constructed his own chemistry laboratory in his parents' home after he graduated from Oberlin College, Ohio in 1885. In 1886, Hall – and independently → *Hérault* in France – discovered an effective method for the production of aluminum based on the → *electrolysis* of dissolved aluminum in molten cryolite. This method is called Hall–Hérault process (see also → *aluminum production*).

Julia Hall (1859–1925), who had also been a chemistry major at Oberlin, was a great assistance to his younger brother; helping with experiments, taking laboratory notes, and later in the business. Hall together with metallurgist Alfred E. Hunt established the Pittsburgh Reduction Company which in 1907 was renamed the Aluminum Company of America (in 1990 this name was shortened to Alcoa). He began to manufacture aluminum at Kensington, Pennsylvania in 1888, then

moved to Niagara Falls because of the cheap electricity that contributed to the falling price of the aluminum.

Ref.: [i] Williams TI (1993) *Endeavour* 17:89

Hall–Héroult process → *aluminum production*, → *Hall, Charles Martin*, and → *Héroult, Paul Louis Toussaint*

H

Hamaker constant — The interaction of macrobodies (i.e., here bodies consisting of an ensemble of molecules) resulting from → *van der Waals forces* can be characterized by the Hamaker constants H_{12} for bodies 1 and 2, and by H_{13} for bodies 1 and 3 with the medium 2 in-between. The Hamaker constants have the dimension of → *energy*. They are responsible for the attractive interaction between colloidal particles, for → *adhesion* of particles to surfaces, etc. The Hamaker constants are material constants that occur in the equation for the → *Gibbs energy* of interaction, here for the case of particle 1 and 2: $\Delta G_{12} = -\pi^2 \rho_1 \rho_2 H_{12} \int_{V_1} dV_1 \int_{V_2} \frac{dV_2}{\pi^2 r_{12}^6}$ (ρ_1 and ρ_2 are the molecular number densities (molecules per volume unit), dV_1 and dV_2 are volume elements of the volumes V_1 and V_2 of the particles 1 and 2, r_{12} is the distance between the particles 1 and 2). When a medium 2 intervenes the particles 1 and 3, the relation between the different Hamaker constants is: $H_{123} \approx (H_{11}^{1/2} - H_{22}^{1/2})(H_{33}^{1/2} - H_{22}^{1/2})$. If the constant H_{22} is intermediate between H_{11} and H_{33} , then H_{123} is negative, and the Gibbs energy of interaction of the particles 1 and 3 is positive, i.e., the particles repel each other. Lifshitz derived interactions, now referred to as Lifshitz constants, from the electrical properties of particles considering the → *frequency* dependence of the → *dielectric constants* of solids and liquids (see also → *dielectric relaxation*). The Lifshitz constants are superior to the Hamaker constants.

Refs.: [i] Evans FD, Wennerström H (1999) *The colloidal domain*. Wiley-VCH, New York, pp 217; [ii] Hunter RJ (2004) *Foundations of colloid science*, 2nd edn. Oxford University Press, Oxford, pp 539; [iii] Hamaker HC (1937) *Physics* 4:1058; Morrison ID, Ross S (2002) *Colloidal dispersions. Suspensions, emulsions, and foams*. Wiley Inter-science, New York, pp 355

FS

Hammett acidity function — The acidity function (H_0) was [i] introduced by Louis Planck Hammett (1894–1987) and co-workers [ii] for characterization of the acidity especially of strong acid solutions of high concentrations. The fundamental idea is the utilization of the protonation of weak bases. The primary systems

used by Hammett based on anilines, [e.g., 2,3,6-trinitro-difenilamine ($pK_a = 10.38$) or 2-trinitro-aniline ($pK_a = 17.88$)], however, several indicators have been studied, and the tabulated H_0 values obtained for different strong acids can be found in several papers and books [iii–v]. The extent of protonation of the indicator molecules depends on the → *activity* of the hydrogen ions in the solution, therefore, a determination of the concentration ratio of the protonated and unprotonated form of the indicator molecules gives information on the hydrogen ion activity of the solution under study. If the light absorption (color) of the two forms is different, the ratio can easily be determined by UV-visible spectrometry. Recently, NMR measurements have also been applied [i]. H_0 can be defined as follows:

$$H_0 = pK_a - \log I = -\lg a_{H^+} - \log \frac{\gamma_B}{\gamma_{BH^+}}, \quad (1)$$

where pK_a is the negative logarithm of the dissociation constant of the protonated weak base (BH^+), I is ratio of c_{BH^+}/c_B , a_{H^+} is the relative activity of hydrogen ions, γ_B and γ_{BH^+} are the respective → *activity coefficients*. At low acid concentrations $H_0 = \text{pH}$. Since the reference system is the pure water, at high acid concentrations – when, in fact, a mixed solvent is present – pK_a may be varied. The H_0 values depend on the nature of the indicator (weak base). The accuracy of the determination I , i.e., the c_{BH^+}/c_B ratio, is in connection with the indicator used. Therefore, the indicator has to be varied when a wide range of acid concentration is studied. For instance, in the case of H_2SO_4 solution, when the concentration is less than 20% *o*-nitroaniline or 4-chlor-2-nitro-aniline can be used, while at $c_{H_2SO_4} > 35\%$ 2,4-dichlor-6-nitro-aniline is the suitable indicator due to its higher pK_a value. See also → *acid–base theories*.

Refs.: [i] (1997) *IUPAC compendium of chemical terminology*, 2nd edn. www.iupac.org/publications/compendium/index.html; [ii] Hammett LP, Deyrup AJ (1932) *J Am Chem Soc* 54:2721, 4239; [iii] Paul MA, Long FA (1957) *Chem Rev* 57:1; [iv] Boyd RH (1969) *Acidity functions*. In: Coetzee JF, Ritchie CD (eds) *Solute-solvent interactions*. Marcel Dekker, New York, pp 97–218; [v] Rochester CH (1970) *Acidity functions*. In: *Organic chemistry, a series of monographs*, vol. 17. Academic Press, New York

GI

Hammett equation (or Hammett relation) — The equation in the form $\log(k/k_0) = \rho\sigma$ or $\log(K/K_0) = \rho\sigma$ applied to account for the influence of *meta*- or *para*-substituents X on the reactivity of the functional group Y in the benzene derivative *m*- or *p*-XC₆H₄Y. k or K is the rate or equilibrium constant, respectively, for the given reaction of *m*- or *p*-XC₆H₄Y; k_0 or K_0 refers to

the reaction of C_6H_5Y , i.e., $X = H$; σ is the substituent constant characteristic of m - or p - X ; ρ is the reaction constant characteristic of the given reaction of Y . The equation is often used in a form with $\log k_0$ or $\log K_0$ written as a separate term on the right-hand side, e.g., $\log k = \rho\sigma + \log k_0$ or $\log K = \rho\sigma + \log K_0$. It then signifies the intercept corresponding to $X = H$ in a regression of $\log k$ or $\log K$ on σ . See also \rightarrow *linear free energy relationship (LFER)*.

Ref.: [i] Muller P (1994) *Pure Appl Chem* 66:1077

WK

Hanging mercury drop electrode — The hanging mercury drop electrode (HMDE) was invented by \rightarrow *Kemula* and his student \rightarrow *Kublik*, and it is sometimes referred to as *Kemula electrode*. It is a spherical stationary mercury electrode of the surface area in the range of a few square millimeters. A mercury drop is dispensed from a glass capillary connected to a mercury reservoir and easily dislodged at any time. The entire construction is very tight, so screwing a stainless-steel wire into the mercury reservoir with the help of a micrometer screw allows the formation of mercury drops with good precision. The HMDE can be used as the working electrode for various electroanalytical purposes, among others for studying the mechanisms and kinetics of electrochemical reactions and for voltammetric determination of various analytes. Particularly important is a possibility of preconcentration of traces of metal ions in the mercury drop followed by anodic dissolution and determination (\rightarrow *anodic stripping voltammetry*).

Ref.: [i] *Kemula W, Kublik Z (1958) Anal Chim Acta 18:104*

ZS

Hansch constant — A measure of the capability of a solute for hydrophobic (lipophilic) interaction (see \rightarrow *hydrophobic effect*) based on the partition coefficient, P , for distribution of the solute between octan-1-ol and water. The most general way of applying P in correlation analysis, etc. is as $\log P$, but the behavior of substituted benzene derivatives may be quantified by a substituent constant scale, π , which is defined in a way analogous to the Hammett σ scale. There are various π scales, depending on the substrate series used as reference. See also \rightarrow *hydrophilicity*.

Ref.: [i] Muller P (1994) *Pure Appl Chem* 66:1077

WK

Hard-sphere electrolyte model \rightarrow *double-layer models*

Hare's cell — This was a copper and zinc \rightarrow *battery* (see also \rightarrow *Volta pile*) where the Cu and Zn plates are wound

in a spiral around each other (with wooden separators in-between). See also \rightarrow *Daniell cell*, \rightarrow *zinc*, \rightarrow Zn^{2+}/Zn electrodes, \rightarrow $Zn^{2+}/Zn(Hg)$ electrodes, \rightarrow *zinc-air batteries (cell)*, and \rightarrow *Leclanché cell*.

Ref.: [i] Hauck WP (1883) *Die Galvanischen Batterien, Accumulatoren und Thermosäulen*, 2nd edn. Hartleben's Verlag, Wien

FS

Haring-Blum cell — A rectangular cell with two cathodes at the small ends with an anode placed between them (see Fig. 1). The two cathodes are connected electrically. Usually the ratio, L , of the two anode-cathode distances is five. Thus a high current density (hcd) and a low current density (lcd) edge results. The Haring-Blum cell is used to determine the macro \rightarrow *throwing power, TP*, of an electrolyte, according to the relation: $TP = (L - M) / (L + M - 2)$ where M is the ratio of the deposited masses.

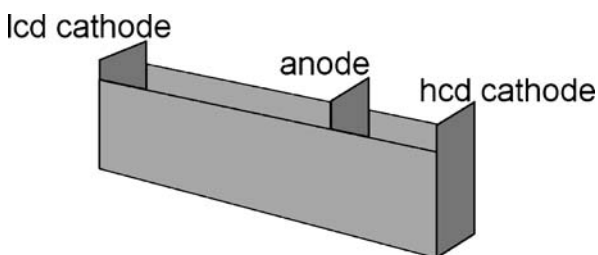

Haring-Blum cell — **Figure.** Schematic representation of the Haring-Blum cell

Ref.: [i] Haring HE, Blum W (1923) *Trans Am Electrochem Soc* 44:313

AB

Hasselbalch, Karl Albert



(Copyright Iben Hasselbalch, Kokkedal)

(Nov. 1, 1874, Aastrup, Denmark – Sep. 19, 1962, Copenhagen, Denmark) Hasselbalch studied medicine and physiology, and received his Dr. med. in 1899 for a work on respiration. In 1903/04 he made a study tour to Berlin and Leipzig [i, ii]. Hasselbalch used the law of mass action for carbonic acid as proposed by \rightarrow *Henderson* to

calculate the $\rightarrow pH$ of blood from the carbon dioxide bicarbonate status [iii, iv]. Therefore the \rightarrow buffer equation is frequently (esp. in the biological sciences) referred to as \rightarrow Henderson–Hasselbalch equation.

Refs.: [i] Schultz JH (1936) *Dansk Biografisk Leksikon*, vol. 9. København; [ii] Saur KG (1994) *Scandinavian Biographical Index*. London; [iii] Hasselbalch KA (1916) *Biochem Z* 78:112; [iv] Warburg E] (1922) *Biochem J* 16153

H

Heat activated battery \rightarrow reserve battery

Heat of transport — The amount of heat absorbed or released when a mol of charged particles i or electrons are transported from one site to another in a phase by a driving force, e.g., concentration gradients, potential differences, and temperature gradients, is called heat of transport (Q_i^*). When the heat of transport is used to calculate the entropy, it is named transport \rightarrow entropy and is also known as Eastman's entropy [i].

$$S_i^* = \frac{Q_i^*}{T} .$$

For migrating particles it is necessary to consider not only the transport entropy, but also the entropy carried by the particle itself.

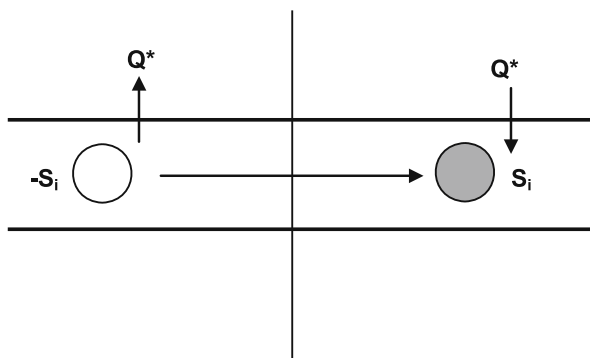

Heat of transport — Figure

For instance, a particle i shown in the figure as an open circle is transported from left to right by a driving force. Thus, when the particle i leaves the left side it releases an amount of heat and when it arrives to the right side it absorbs the same amount of heat if the phase and conditions are the same. An entropy balance at the right-hand side comprises both transport entropy and molar entropy.

$$S_i^\# = S_i^* + S_i .$$

The explanation of the heat of transport is given by the 'hindrance energy' Q_H and the 'gap formation energy' Q_G for a particle [i, ii]. The 'gap formation energy' is the energy necessary to form a hole to insert a particle i in a determined place; on the other hand, the 'hindrance energy' is the energy necessary for the entrance of the particle into the hole formed. The heat of transport is a function of both contributions.

$$Q_i^* = Q_H + Q_L .$$

For electrolyte solutions the heat of transport depends on both temperature and concentration. Experimental studies have found that the heat of transport increases with temperature. For diluted electrolyte solutions the heat of transport decreases when the concentration is higher, while for concentrated electrolyte solutions the heat of transport increases with higher concentrations.

Refs.: [i] Agar JN (1963) *Thermogalvanic cells*. In: Delahay P (ed) *Advances in electrochemistry and electrochemical engineering*, vol. 3. Interscience, New York, pp 31–121; [ii] Lange E, Göhr H (1962) *Thermodynamische Elektrochemie*. Hüthig, Heidelberg

MBS

Heated electrodes — Electrodes which are heated in situ, forming part of a nonisothermal \rightarrow electrochemical cell. Preferred techniques of electrode heating are laser irradiation, inductive heating, and direct electric heating by \rightarrow alternating current. The latter technique became practicable when AC distortions could be avoided by introducing a symmetrical electrode arrangement. When applied to thin wire electrodes, the term "hot-wire electrodes" is used occasionally. Different from other heating principles mentioned, direct electrical heating allows to design microsensors driven by simple equipment. By pulsed heating, temperature values far above the boiling point of the surrounding solution have been achieved. Temperature-pulse \rightarrow voltammetry (TPV) is based on this technique. Permanent heating generates a continuous, precisely controllable convection.

Heated electrodes are useful as chemical \rightarrow sensors, preferably in bioanalytical applications like DNA hybridization analysis. Other applications are kinetic studies using the temperature pulse method, and determination of physicochemical constants like redox entropy, etc.

Refs.: [i] Climent V, Coles BA, Compton RG, Feliu JM (2004) *J Electroanal Chem* 561:157 [ii] Qiu FL, Compton RE, Marken F, Wilkins SJ, Goetting CH, Foord JS (2000) *Anal Chem* 72:2362 [iii] Gründler P, Flechsig G-U (2006) *Microchim Acta* 154:175

PG

Hebb–Wagner method — is a technique to study electronic conductivity in \rightarrow *solid electrolytes*, based on the use of one ion-blocking \rightarrow *electrode* (electronic filter) under \rightarrow *steady-state* conditions. The filter is to be made of an electronically-conducting material, inhibiting supply or removal of ionic \rightarrow *charge carriers* in/from the electrolyte; examples include the carbon electrode for cation-conducting solids and hermetically-encapsulated platinum electrode for \rightarrow *stabilized zirconia*. Another electrode should be, in theory, \rightarrow *reversible*. Assuming that (i) blocking is ideal and the effect of other boundary conditions is negligible, (ii) the \rightarrow *mobilities* of electronic charge carriers are concentration-independent, (iii) the relationships between \rightarrow *concentration* and \rightarrow *chemical potential* of the electronic charge carriers are expressed in terms of Boltzmann statistics, and (iv) all \rightarrow *activity coefficients* are constant, the current-voltage ($I-U$) dependence of such a cell is expressed as

$$I = \frac{RT}{FK_G} \cdot \left\{ \sigma_n^0 \left[1 - \exp\left(-\frac{FU}{RT}\right) \right] + \sigma_p^0 \left[\exp\left(\frac{FU}{RT}\right) - 1 \right] \right\},$$

where K_G is the constant describing geometry of the cell, F is the \rightarrow *Faraday constant*, R is the \rightarrow *gas constant*, T is the temperature, and σ_p^0 and σ_n^0 are the partial p-type and n-type electronic conductivities at unit activity of the potential-determining component, respectively. The electronic contributions to the total conductivity can thus be studied as a function of the potential-determining component activity, varying this activity at ion-blocking electrode by the applied voltage. If one type of the electronic charge carriers is prevailing, or when the absolute value of the voltage is high enough, the electronic conductivity can be calculated from the slope (dI/dU) using the appropriate geometrical constant.

This technique can be even applied if the conditions (ii), (iii), and (iv) are not observed. In the latter case, however, regression analysis of the $I-U$ dependencies requires to define explicit relationships between chemical potentials of all components, their concentrations, and mobilities. In practice, experimental problems are often observed due to leakages, non-negligible \rightarrow *polarization* of “reversible” electrodes, indefinite contact area between solid electrolyte and electronic filter, formation of depletion layers and/or phase decomposition of the electrolyte.

Historically, this method was suggested by Wagner [i] following the work by Hebb [ii], who first proposed to use ion- or electron-blocking electrodes for the determination of partial conductivities in a 4-probe arrange-

ment. Now various modifications of steady-state measurements with blocking electrodes are often referred to as the Hebb–Wagner method.

Refs.: [i] Wagner C (1956) *Z Elektrochem* 60:4; [ii] Hebb MN (1952) *J Chem Phys* 20:185; [iii] Kröger FA (1964) *The chemistry of imperfect crystals*. North-Holland, Amsterdam

VK

Helical potentiometer — A metal wire wound around an insulating cylinder used as variable \rightarrow *voltage divider*. A helical potentiometer has been used in the first \rightarrow *polarograph* developed by \rightarrow *Heyrovský* and \rightarrow *Shikata*. The helical potentiometer with a sliding contact was invented by \rightarrow *Kohlrausch* (in German: Kohlrausch Walze). A commercial version is called a Helipot.

Ref.: <http://physics.kenyon.edu/EarlyApparatus/>

FS

Helipot \rightarrow *helical potentiometer*

Helmholtz, Hermann Ludwig Ferdinand von



(Photo 1891)

(Aug. 31, 1821, Potsdam, Germany – Sep. 8, 1894, Berlin, Germany). One of the 19th century’s greatest scientists, Helmholtz made important discoveries in physiology, optics, electrodynamics, mathematics, thermodynamics, and meteorology [i]. Helmholtz obtained medical education, and in the beginning of his scientific career he performed studies in physiological optics and sensing that were summarized in his famous books ‘Handbuch der physiologischen Optik’ (Handbook of Physiological Optics, 1856) [ii] and ‘Die Lehre von den Tonempfindungen als physiologische Grundlage für die Theorie der Musik’ (Sensation of Tone as a Physiological Basis for the Theory of Music, 1863) [3]. Mathematic and theoretic interests of Helmholtz brought him to the studies of non-Euclidean geometry and cosmogonic problems. Helmholtz contributed to the studies of the nature of electricity and understanding of electrodynamic

ics. Helmholtz was interested in and had studied electrochemistry, particularly the nature of the \rightarrow *galvanic cell*. He is mostly known to electrochemists for the formulation of the charged \rightarrow *double layer* at an electrode/electrolyte interface [iv].

Refs: [i] Cahan D (ed) (1993) *Hermann von Helmholtz and the foundations of nineteenth-century science*. University of California Press, Los Angeles; [ii] Helmholtz HLF (1896) *Handbuch der physiologischen Optik*, 2nd edn. Voss, Hamburg; [iii] Helmholtz HLF (1863) *Die Lehre von den Tonempfindungen als physiologische Grundlage für die Theorie der Musik*. Vieweg, Braunschweig; [iv] Helmholtz HLF (1879) *Wied Ann* 7:337

EK

Helmholtz energy — Symbol: A , SI unit: J

Helmholtz energy (sometimes also called Helmholtz free energy, or Helmholtz function) is the thermodynamic state function equal to the maximum possible nonexpansion work output, which can be done by a closed system in an isothermal isochoric process ($T = \text{const}$, $V = \text{const}$). In terms of the \rightarrow *internal energy* and \rightarrow *entropy*

$$A \equiv U_E - TS.$$

The physical meaning of the Helmholtz free energy is similar to that of the \rightarrow *Gibbs energy*, both being criteria to define \rightarrow *equilibrium*. The equilibrium criterion in a closed system, which is only capable of doing P - V work and held at constant temperature and volume, is the minimum of Helmholtz energy. See also \rightarrow *Helmholtz*.

Ref.: [i] Levine IN (1995) *Physical chemistry*, 4th edn. McGraw-Hill, New York

VK

Helmholtz free energy \rightarrow *Helmholtz energy*

Helmholtz function \rightarrow *Helmholtz energy*

Helmholtz plane and layer \rightarrow *double layer*

Heme — Heme is a protoporphyrinato-IX iron complex which is biosynthesized from acetate and glycine [i]. Naturally, the iron metal center occurs in the oxidation states II, III, and IV and Fe(III) heme is also called \rightarrow *hemin*. The heme unit is essential (the prosthetic group) in \rightarrow *hemoglobin*, \rightarrow *cytochrome c*, cytochrome P450s, and in myoglobin [i]. In hemoglobin and myoglobin the heme group is weakly bound to the protein via histidine coordination to iron. However, in cytochrome *c* two covalent S-C bonds evolved.

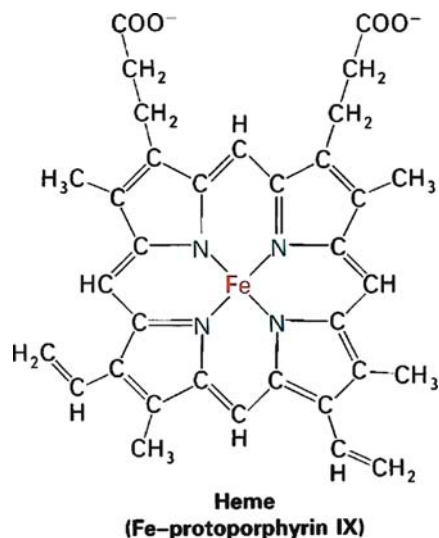

Heme — Figure

The biological function of the heme unit varies from electron transporter (cytochrome *c*), oxygen transporter (hemoglobin and myoglobin), to catalytic site for metabolic processes such as C-H activation (cytochrome P450). In electrochemistry heme systems are popular model redox systems. They have been employed as an active sensor component [ii] or as an electrocatalyst for dehalogenation and mono-oxygenation processes [iii].

Refs.: [i] Stryer L (1995) *Biochemistry*. WH Freeman, New York; [ii] Bishtolas N, Wollenberger U, Jung C, Scheller FW (2005) *Biosens Bioelectronics* 20:2408; [iii] Rusling JE, Forster RJ (2003) *J Coll Interface Sci* 262:1

FM

Hemin — The Fe(III) form of \rightarrow *heme*.

FM

Hemoglobin — Approximately spherical protein (molecular weight ca. 64 kD, diameter ca. 5.5 nm) consisting of four similarly sized subunits each with a prosthetic \rightarrow *heme* group [i]. The four iron atoms are in Fe(II) oxidation state and they bind and transport oxygen from the lungs to the rest of the body. The four heme units interact to give specific oxygen transport properties and the protein has additional functionality for CO₂ and proton transport [ii]. In electrochemistry, hemoglobin has been demonstrated to undergo \rightarrow *electron transfer* to the Fe(III) oxidation state (methemoglobin) and to the Fe(I) oxidation state. Hemoglobin immobilized at electrode surfaces can act as active electrochemical \rightarrow *sensor* (for hydrogen peroxide, cyanide, carbon monoxide, NO, nitrite, trichloroacetate, etc.) or

as electrocatalyst for dehalogenation and oxygenation processes [iii].

Refs.: [i] Weissbluth M (1974) *Hemoglobin*. Springer, Berlin; [ii] Stryer L (1995) *Biochemistry*. WH Freeman, New York; [iii] Zhou YL, Hu NF, Zeng YH, Rusling JF (2002) *Langmuir* 18:211

Ref.: [i] Muller P (1994) *Pure Appl Chem* 66:1077

WK

Henry, Joseph

FM



Henderson, Lawrence Joseph



(June 3, 1878, Lynn, Massachusetts, USA – Feb. 10, 1942 Boston, USA) Henderson studied medicine at Harvard and was Professor of Biological Chemistry at Harvard University, Cambridge, Massachusetts, from 1904 to 1942 [i]. Henderson published on the physiological role of \rightarrow buffers [ii–vii] and the relation of medicine to fundamental science. Because he and also \rightarrow Hasselbalch made use of the law of mass action to calculate the \rightarrow pH of solutions containing corresponding acid-base pairs, the buffer equation is frequently (esp. in the biological sciences) referred to as \rightarrow Henderson–Hasselbalch equation.

Refs.: [i] Salié H (ed) (1973) *JC Poggendorff Biographisch-literarisches Handwörterbuch der exakten Naturwissenschaften, vol. VIIb*. Akademie-Verlag, Berlin; [ii] Henderson LJ (1908) *Am J Physiol* 21:173; [iii] Henderson LJ, Spiro E (1908) *Biochem Z* 15:105; [iv] Henderson LJ (1908) *J Am Chem Soc* 30:954; [v] Henderson LJ, Black OF (1908) *Am J Physiol* 21:420; [vi] Henderson LJ (1909) *Ergebn Physiol* 8:254; [vii] Henderson LJ (1910) *Biochem Z* 24:40; [viii] Henderson LJ (1909) *Erg Physiol* 8:254

FS

Henderson equation \rightarrow diffusion potential

Henderson–Hasselbalch equation (buffer equation) — is the equation $\text{pH} = \text{p}K_a - \lg\left(\frac{[\text{HA}]}{[\text{A}^-]}\right)$, where K_a is acid dissociation constant, and $[\text{HA}]$ and $[\text{A}^-]$ are the concentrations of the acid and corresponding base, respectively. The equation is used to calculate the \rightarrow pH of \rightarrow buffer solutions. See also \rightarrow Henderson, \rightarrow Hasselbalch.

(Dec. 17, 1797, Albany, New York, USA – May 13, 1878 Washington, DC, USA) Son of William Henry (1764–1811) and Ann Alexander (1760–1835) who were both immigrants to the USA from Scotland. The untimely death of his father compelled him to become apprenticed to a local watchmaker in his mid-teens. However, between 1819 and 1822 he was able to obtain a formal education at the recently-opened Albany Academy. He was appointed Professor of Mathematics and Natural Philosophy there in 1826. In 1832 he became Professor of Natural Philosophy in the College of New Jersey (now Princeton University), where he remained until 1846. In that year the United States government received the then-astonishing sum of half a million dollars as a bequest from the English chemist James Smithson, which they used to found the Smithsonian Institution. On 3 December 1846 Henry became its first Secretary (Director). At the height of his career he was a technical adviser to Abraham Lincoln. However, most of Henry's discoveries took place during the Albany years. In 1831, he constructed a functioning electric telegraph, though he did not patent it. Also around 1831, he improved the electromagnet design of William Sturgeon (1783–1850), which he did by insulating the windings. By 1832 he had built an electromagnet so powerful that it could lift “between six hundred and seven hundred pounds” [i]. While carrying out these experiments, Henry observed that a spark was generated when breaking a circuit containing a long wire, but not when breaking a circuit containing a short wire. He soon realized that the spark was caused by the primary current in the long wire acting upon itself. This was the first experimental observation of self-inductance [i]. Although this secured his place in history, he was careful not to extend his claim to the induction of secondary currents. “The secondary currents, as it is well known, were discovered

in the induction of magnetism and electricity, by Dr Faraday, in 1831" [ii]. Thus, Henry was the discoverer of self-inductance, while → *Faraday* was the discoverer of mutual inductance [ii]. Throughout his life, Henry promoted high ethical standards in scientific research. Indeed, he once remarked that, "I think that immorality and great mental power are incompatible with one another, and that more error is introduced from defect in moral sense than from want of intellectual capacity." Today, the → *SI unit* of inductance the henry (symbol H) is named in his honor.

Refs.: [i] Henry J (1832) *Am J Sci Arts* 22:403; [ii] Henry J (1839) *Trans Am Philos Soc (NS)* 6:303

SF

HER (hydrogen evolution reaction) → hydrogen

Herasymenko, Polikarp — (1900 Odessa – 1959 New York) Co-worker of → *Heyrovský, J.* in Prague, later at the Iron & Steel Institute (Washington, DC) and professor at New York University, College of Engineering. Often quoted is his work on reduction of hydrogen ions at mercury electrodes, done in Prague with his colleague I. Slendyk [i–iii].

Refs.: [i] Herasymenko P, Slendyk I (1930) *Z phys Chem A* 149:123; [ii] Slendyk I, Herasymenko P (1932) *Z phys Chem A* 162:223; [iii] Herasymenko P, Slendyk I (1934) *Coll Czech Chem Commun* 6:204

MHey

Héroult, Paul Louis Toussaint



(Apr. 10, 1863, Thoury-Harcourt, France – May 9, 1914, near Antibes, on the sea) Already as a high-school student he started to be interested in discoveries. He was fascinated by the book of Henri Étienne Sainte-Claire Deville (1818–1881) about aluminum, and decided that he would produce aluminum by electrical means at a reasonable price. He entered the Ecole des Mines, Paris in 1882 where he began working on the electrolysis of aluminum compounds. In 1886 – simultaneously with

→ *Hall* – he elaborated the effective technology of production of aluminum by electrolysis (see → *aluminum production*, → *Hall–Héroult process*).

The first aluminum plant was built in Neuhausen, on the banks of the Rhine. In 1888 the Société Electrometallurgique Francaise was founded for production of aluminum where Héroult became the technical director. Later this company merged with the Société Francaise de l'Aluminium Pur at which Héroult was also involved in research. Héroult is also noted for his electric furnace named for him.

Refs.: [i] <http://www.geocities.com/bioelectrochemistry/heroult/htm>; [ii] Williams TI (1993) *Endeavour* 17:89

GI

Hersch cell → *Galvanic cell* developed by Hersch for the quantitative determination of oxygen. The principle of the cell is that oxygen is reduced at the cathode (typically made of graphite or silver) while a suitable anode (such as lead or cadmium) is simultaneously oxidized. The current delivered by this → *galvanic cell* is proportional to the oxygen concentration in a gas or in a solution provided that the mass transport to the cathode is controlled, e.g., by the passage of the oxygen through a membrane. See also → *Clark electrode*.

Refs.: [i] Hersch PA (1952) *Nature* 169:792; [ii] Hersch PA (1964) *Galvanic analysis*. In: Reilley CA (ed) *Advances in analytical chemistry and instrumentation*, vol. 3. Interscience, New York; [iii] Hersch PA (1965) *US Patent* 3223597; [iv] Bahmet W, Hersch PA (1971) *Anal Chem* 43:803; [v] Rigby R, Lynch JT, Dewey DL, Michael BD (1975) *J Phys E: Sci Instrum* 8:258

FS

Hertz, Heinrich Rudolf



(Photo 1888–89)

(Feb. 22, 1857, Hamburg, Germany – Jan. 1, 1894, Bonn, Germany). Hertz was a physicist who experimentally proved the existence of electromagnetic waves theoretically predicted by Maxwell [i, ii]. He was the first (1885–1889) to generate and receive → *electromagnetic waves*

(radio waves) in the laboratory using spark discharges. He demonstrated that electromagnetic waves were reflected and refracted like light waves and, most important, that they traveled at the same speed as light but had a much longer wavelength. Hertz also noted that electrical conductors reflect the waves and concave reflectors can focus them. He found that nonconductors allow most of the waves to pass through. In 1884, Hertz contributed to the development of the theory of electromagnetic waves deriving → *Maxwell's equations* by a new method, casting them in modern form without assumption of either. He also discovered the photoelectric effect (which was later explained by → *Einstein*) when he noticed that a charged object loses its charge more readily when illuminated by ultraviolet light.

Refs.: [i] Lenard P (ed), Jones DE (transl) (1896) *Hertz H: Miscellaneous papers*. Dover, London; Lenard P (ed), Jones DE (transl) (1893, reprinted 1962) *Hertz H: Electric waves*. Dover, London; Lenard P (ed), Jones DE (transl) (1899, reprinted 1955) *Hertz H: The principles of mechanics*. Dover, London; [ii] Lodge O (1894) *The work of Hertz and some of his successors*. Electrician Printing and Publishing, London

EK

Heteroepitaxial metal deposition → *epitaxial metal deposition*

Heterogeneous charge transfer reaction → *charge-transfer reaction*

Heterojunction cell — Short designation for heterojunction photovoltaic cell. Heterojunction cells make use of different → *semiconductors* to produce interfaces with energy discontinuities, aiming the facilitation of dissociation of photoinduced excited charge pairs. This cell configuration differs from homojunction cells, like p–n junction based cells, where an internal electric field for charge dissociation is obtained at the interface separating the p-doped from the n-doped regions of the same host semiconductor. (See also → *photovoltaic device*).

Refs.: [i] Gregg BA, Ferrere S, Pichot F (2002) *Interfacial process in organic-based solar cells*. In: Kafafi ZH (ed) *Organic photovoltaics II – Proceedings of SPIE*, vol. 4465. Washington, pp 31–42; [ii] Ng KK (2002) *Complete guide to semiconductor devices*. Wiley, New York

IH

Hevesy, György*



(© The Nobel Foundation)

(Aug. 1, 1885, Budapest, Hungary (Austro-Hungarian Empire) – July 5, 1966, Freiburg, Germany) He studied at Budapest University and Berlin Technical University and he gained his doctor's degree at the University of Freiburg in 1908. He worked in Zürich, in Berlin (with → *Haber*), in Manchester (with Ernest Rutherford) as well as in Budapest (in the laboratory of Gusztáv Buchböck).

In 1913 he carried out the first radioactive tracer experiment with Friedrich Adolf Paneth in Vienna [i]. After the service in the Austrian–Hungarian Army during the war he became a professor at Budapest University. By the help of radiotracer technique he first proved the existence of heterogeneous and homogeneous → *electron transfer* reactions [ii]. He also introduced the concept of → *self-diffusion* [iii]. He left Hungary in 1919, and worked in Copenhagen at Niels Bohr's Institute where he discovered the element hafnium (with D. Coster). In 1926 he became a professor at Freiburg University, however, he left Germany for Copenhagen in 1934. He elaborated the method of neutron activation analysis [iv] and prepared $^{32}_{15}\text{P}$ isotope which became a very useful indicator in physiological studies [v]. He moved to Stockholm in 1943, and worked at the Stockholm University during the next 23 years.

In 1943 he received the Nobel Prize in Chemistry “for his work on the use of isotopes as tracers in the study of chemical processes” [vi].

* Also written as: Georg Karl von Hevesy, Georg Hevesy, George Charles de Hevesy, George de Hevesy, George Hevesy

Refs.: [i] Hevesy G, Paneth F (1913) *Z Anorg Chem* 82:323; [ii] Hevesy G, Zechmeister L (1920) *Z Elektrochem* 23:151; [iii] Gróh J, Hevesy G (1920) *Ann Phys* 63:85 and (1921) 65:216; [iv] Hevesy G, Levi H (1935) *Nature* 136:754; [v] Hevesy G, Ghiewitz O (1935) *Nature* 136:754;

[vi] http://nobelprize.org/nobel_prizes/chemistry/laureates/1943/index.html

Heyrovský, Jaroslav



(Courtesy of Dr. Michael Heyrovský)

(Dec. 20, 1890, Prague, Austro-Hungarian Empire – Mar. 27, 1967, Prague, Czechoslovakia, now Czech Republic). Heyrovský was a pioneer of electroanalytical chemistry. Inspired by → *Kučera*, Heyrovský studied the → *potential* dependence of → *interfacial tension* at the mercury|electrolyte solution interface with the help of the → *dropping mercury electrode* (→ *drop time method*). In the course of these studies he discovered → *polarography*, the predecessor of all modern voltammetric techniques [i–v]. Polarography is based on the use of a dropping mercury electrode (DME) with a linearly varying potential. In 1924 he designed (with the assistance of → *Shikata*) the first electroanalytical device – the → *polarograph*. This was the first analytical instrument with automatic registration of a measuring curve. He studied the basic features of polarography, the polarographic behavior of numerous inorganic and organic compounds, and he is the author of fundamental books on that method, [e.g., vi–ix]. Heyrovský received the Nobel Prize in Chemistry in 1959, “for his discovery and development of the polarographic methods of analysis”. See also → *Brdička*, → *Herasymentko*, → *Kalousek*, → *Kemula*, → *Kolthoff*, → *Koryta*, → *Kůta*, → *Ilkovič*, → *Smoler*, → *Ševčík*.

Refs.: [i] Zuman P (2001) *Crit Rev Anal Chem* 31:281; [ii] Hulanicki A (2004) *Chem Analityczna* 49:763; [iii] Heyrovská R (1998) *Curr Sci* 74:554; [iv] Koryta J (1991) *Electrochim Acta* 36:221; [v] Walsh J (1993) In: James LK (ed) *Nobel laureates in chemistry 1901–1992*. American Chemical Society, New York, pp 412–418; [vi] Heyrovský J (1933) *Použití polarografické metody v praktické chemii*. Knihotiskárna Jednoty československých matematiků a fysiků. Prague; [vii] Heyrovský J (1941) *Polarographie*. Springer, Wien; [viii] Heyrovský J, Kůta J (1965) *Principles of polarography*. Czechoslovak Academy of Sciences, Prague; (American ed: Heyrovský J, Kůta J (1966) *Principles of polarography*. Academic

Press, New York; German ed: Heyrovský J, Kůta J (1965) *Grundlagen der Polarographie*. Akademie-Verlag, Berlin); [ix] Heyrovský J, Zuman P (1968) *Practical polarography, an introduction for chemical students*. Academic Press, London

EK

Heyrovský–Ilkovič equation → *Ilkovič, Dionýz*

Heyrovský reaction → *hydrogen evolution reaction*

High-field oxide growth — Many metal oxides are ceramic-like ionic and electronic insulators. Their anodic growth cannot be explained by → *diffusion* of ions as the → *diffusion coefficients* are much too small to enable growth rates with current densities up to $A\text{ cm}^{-2}$. The high-field model assumes an electric field strength E of about 10^8 V m^{-1} perpendicular to the surface which is calculated from the potential drop $\Delta\phi$ across the oxide film (e.g., 10 V) with a thickness d (e.g., 20 nm), yielding values such as $E = \Delta\phi/d = 5 \times 10^7\text{ V m}^{-1}$. These field strengths are sufficient to cause a migration of cations or anions through the oxide film. The ratio of cation and anion movement is given by the → *transport numbers* [i] which vary from $t_+ = 1$ (pure cation movement) to $t_+ = 0$ (pure oxygen ion movement, e.g., Hf, Zr). Normally, transport numbers are closer to 0.5 (e.g., Al, Nb, Ta, Ti).

The migration process is described as a thermally activated, field-supported hopping process of ions between neighbored sites of minimum energy within the oxide lattice [ii]. The activation energy W is significantly lowered in one direction due to the electric field which results in an ion transport in this direction. The current density j corresponding to this ion flux is given by

$$j = j_0 \exp(\beta E) = j_0 \exp\left(\frac{\beta \Delta\phi}{d}\right) \quad (\text{i})$$

with the oxide specific constants j_0 and β :

$$j = \nu \rho a \exp\left(-\frac{W}{RT}\right) \text{ and } \beta = \frac{\alpha z a F}{RT}, \quad (\text{ii})$$

where ν is the vibration frequency of the ions (around $6 \times 10^{12}\text{ s}^{-1}$ at room temperature), ρ [C m^{-3}] is the density of mobile charge, a the hopping distance (0.5 to 1 nm), α a symmetry factor of the barrier, z the charge number of the ion, and F the → *Faraday constant*. Equation (i) excludes thickness changes as a result of current flow; the time-dependent thickness is given by

$$\frac{\partial d}{\partial t} = \frac{j_0 M}{\rho_{\text{ox}} y F} \exp\left(\frac{\beta \Delta\phi}{d}\right), \quad (\text{iii})$$

where M and ρ_{ox} are the molecular mass and the mass density of the oxide and γ is the number of electrons needed to form one oxide molecule. The differential Eq. (iii) must be solved by numeric integration.

This model locates the rate-determining step within the oxide; however, it can also be located at the interfaces without differences in the mathematical description [iii].

Refs.: [i] Pringle JPS (1980) *Electrochim Acta* 25:1423; [ii] Verwey EJW (1935) *Physica* 2:1059; Lohrengel MM (1993) *Mater Sci Eng R11*:243; [iii] Cabrera N, Mott NF (1948–49) *Rep Prog Phys* 12:163

MML

Higgins cell — This was a chromic acid (carbon electrode) – zinc → battery constructed in such a way that the chromic acid electrolyte was stirred to reduce concentration polarization. See also → *chromic acid battery*, → *Daniell cell*, → *zinc*, → *Zn²⁺/Zn electrodes*, → *Zn²⁺/Zn(Hg) electrodes*, → *zinc-air batteries (cell)*, and → *Leclanché cell*.

Ref.: [i] Hauck WP (1883) *Die Galvanischen Batterien, Accumulatoren und Thermosäulen*, 2nd edn. Hartleben's Verlag, Wien

High field mechanism → *passivation*

High-pass filter → *signal filtering*

Highly-oriented pyrolytic graphite electrode → *graphite electrode*

Hittorf, Johann Wilhelm

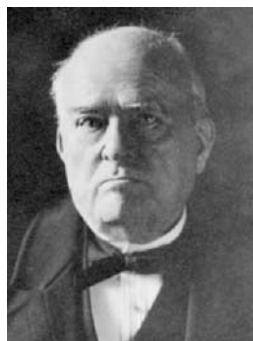

(Courtesy of Universitätsarchiv, Westfälische Wilhelms-Universität Münster)

(Mar. 27, 1824, Bonn, Germany – Nov. 28, 1914, Münster, Germany) His early work at Berlin was carried out on the allotropes of selenium and phosphorus, but he is remembered for his work on ionic transport and cathode rays, in both areas making substantial contributions. In ionic transport theory, he was the first to formulate laws about the separate → *migration* of oppositely charged ions to anode and cathode compartments and to derive a method for the measurement of

the fraction of charge carried by the different migrating ions. These fractions he termed → *transport numbers*, and they have proved to be highly significant both technically and fundamentally. His developmental work on ionic transport mainly took place between 1853 and 1859, but remained an important area of study for him for over fifty years, and is remarkable because many of the measurements were made before the → *Arrhenius* theory of ionic dissociation reached its final form. In 1869 he discovered that the cathode rays recently identified by Julius Plücker at Marburg were propagated in straight lines provided no magnetic fields were present, and that physical objects placed between the cathode and the illuminated side of the tube cast a shadow. His work in this area was extended by Crookes, who developed an improved vacuum pump allowing the production of cathode rays with reduced residual gas in the tube. In 1879 he became Professor of Physics and Chemistry at the University of Münster, and Director of laboratories there until 1889, but continued his studies well after retirement.

FS See also → *Tubandt method* for the determination of transport numbers in → *solid electrolytes*.

Ref.: [i] Ostwald W (1896) *Elektrochemie. Ihre Geschichte und Lehre. Veit Comp, Leipzig*; (engl transl: Ostwald W (1980) *Electrochemistry. History and theory*, 2 vols. Amerind Publ, New Delhi)

AH

Hittorf transport method — Only at infinite dilution can the molar conductivity of a solution be split into the two limiting molar conductivities associated with the individual ions, which are independent of each other. This is because only at infinite dilution can we completely neglect interionic interactions. However, in order to determine the values of the individual ionic conductivities, an additional measurement is necessary in order to partition Λ_0 into λ_0^+ and λ_0^- ; we must determine the so-called → *transport numbers* of the individual ions. The total current i , can be written as the sum of partial currents i^+ and i^- , corresponding to the currents carried by the cations and anions. We define the transport number of the cations, t^+ , as $t^+ = \frac{i^+}{i^+ + i^-} = \frac{u^+}{u^+ + u^-}$ and similarly $t^- = \frac{i^-}{i^+ + i^-}$ and from these definitions it can clearly be seen that $t^+ + t^- = 1$ and that $t^+ = \frac{\nu_+ \lambda^+}{(\nu_+ \lambda^+ + \nu_- \lambda^-)}$, where ν_+ and ν_- are the numbers of cations and anions formed for each molecular formula unit dissolved and λ^+ , λ^- the individual ionic molar conductances. Strictly, these only have a real meaning at infinite dilution but as we will see below, they remain good approximations to quite high concentrations, so the values of the lim-

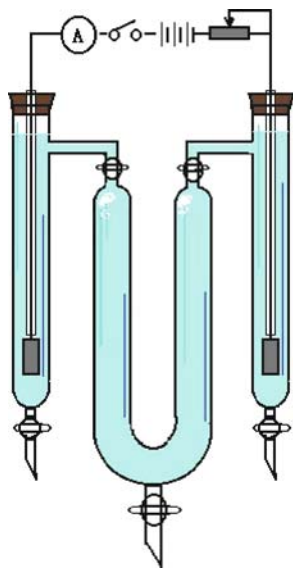

Hittorf transport method — Figure

iting ionic conductivities λ_0^+ , λ_0^- are accessible provided that we can measure Λ_0 and we can determine the transport numbers of anion and cation at reasonably high dilutions.

Experimentally, the partition of the charge transport from anion and cation was first investigated by \rightarrow Hittorf in the years 1853–1859. For this purpose, Hittorf used, inter alia, the arrangement shown, comprising three compartments, an anode, cathode, and a third, intervening compartment. As an example, we could have a cell consisting of an anode and cathode formed from platinum and an electrolyte of hydrochloric acid. On current flow, hydrogen is evolved at the cathode and chlorine gas at the anode, and on the passage of one Faraday ($\equiv N_A e_0$, where N_A is the Avogadro constant and e_0 the electronic charge, and has the value of $\sim 96,485$ coulomb mol^{-1}) through the cell, the following changes in composition will be observed in the various parts of the cell, as given in the Table.

In total, t^+ mol HCl have disappeared from the anode compartment and t^- mol HCl from the cathode compartment. By quantitatively analyzing the solutions around the anode and cathode before and after the passage of a known amount of charge, it is, therefore, possible to determine the transport numbers. It is also clear that the principle of Hittorf's method, sketched above, can be extended without difficulty to

Hittorf transport method — Table. Changes in composition on passage of one Faraday of charge through hydrochloric acid

Anode space	Cathode space	Process
$-t^+$ mol H^+	$+t^+$ mol H^+	The cation contribution to the charge passed is t^+F , and this is the charge transported by the cations as they move from the anode compartment to the cathode compartment.
$+t^-$ mol Cl^-	$-t^-$ mol Cl^-	This corresponds to the transport of charge t^-F by the anions which migrate from the cathode compartment towards the anode compartment.
-1 mol Cl^-	-1 mol H^+	Evolution of $1/2 \text{H}_2$ from the cathode compartment and $1/2 \text{Cl}_2$ from the anode compartment.
$(t^- - 1)$ mol Cl^- $-t^+$ mol H^+	$(t^+ - 1)$ mol H^+ $-t^-$ mol Cl^-	Sum of processes
$= -t^+$ mol HCl	$= -t^-$ mol HCl	

other systems whose ionic composition and electrode reactions are known. However, in any measurement, care must always be taken to ensure that the concentration differences generated by the passage of current are not reduced either by back-diffusion or by stirring of the solution associated, for example by the evolution of gas bubbles at either of the two electrodes. The first problem can be tackled by using a long diffusion path length between the anode and cathode compartments and short measuring times, and the second by placing frits between the two compartments. In more precise measurements, correction must also be made for concentration changes arising from the unequal transport of water molecules in the \rightarrow hydration sheaths of the two ions. It is also possible to carry out such measurements in nonaqueous solvents and in molten and solid electrolytes (\rightarrow Tubandt method).

Refs.: [i] Robinson RA, Stokes RH (1970) *Electrolyte solutions*. Butterworths, London; [ii] Hamann CH, Hamnett A, Vielstich W (1998) *Electrochemistry*. Wiley-VCH, Weinheim

AH

HMDE (hanging mercury drop electrode) \rightarrow Kemula electrode

Höber, Rudolf

(Reproduced with permission of Springer from *Pflügers Archiv* (1954) 254:1)

(Dec. 27, 1879 Stettin, Germany, now Szczecin, Poland – Sep. 5, 1953, Philadelphia, USA) Höber completed his medical degree at the University of Erlangen in 1898 [i].

From his first academic appointment at the University of Zurich (1897–1909), and then at the Institute of Physiology, University of Kiel (1909–1933), Höber focused his research interests on the physicochemical nature of the cell membrane. In consultation with → *Nernst*, he devised exquisite dielectric measurements (using a motor-car ignition coil and a spark gap in a modified Wheatstone bridge) to demonstrate for the first time that normal cells consist of an electrically insulating ‘envelope’ that surrounds a conducting electrolyte in the cell interior [ii]. This same approach, using more sophisticated equipment, led to the first indication of the ultrathin molecular thickness of the cell membrane [iii]. His crowning achievement, which established his reputation as an international authority in ‘general physiology’, was his monograph “*Physikalische Chemie der Zelle und der Gewebe*” (1st ed. 1902–7th ed. 1926).

In 1931 at Kiel, he chaired a university disciplinary court that expelled six pro-Nazi students on assault charges. As a result of this, in 1933, he was forced into retirement by the Education Ministry [i]. In 1934 he accepted a visiting professorship at the School of Medicine, University of Philadelphia, and between 1936 and 1949 was a staff member of the summer course in Physiology at the MBL, Woods Hole, USA.

Refs.: [i] *Amberson WR* (1954) *Science* 120:199; [ii] *Höber R* (1910) *Pflüger's Arch f d ges Physiol* 133:237, 254; (1912) 148:189; (1913) 150:15; [iii] *Fricke H* (1925) *Phys Rev* 26:682

Hofer–Moest reaction (non-Kolbe electrolysis) — A two-electron variation (1902) of the Kolbe reaction (→ *Kolbe synthesis*): Salts of aliphatic acids (carboxylate

anions) are anodically oxidized under elimination of CO₂ and the formed radicals undergo further oxidation yielding carbocation. The latter can eliminate a proton (giving rise to an alkene), react with nucleophiles, or undergo rearrangements with follow-up reactions. Typical medium is a mixture of dipolar organic solvent with water; electron-donating substituents on the α-carbon stabilize the originating carbocations.

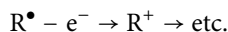

Refs.: [i] *Chkir M, Lelandais D* (1981) *Can J Chem* 59:945; [ii] *Wladislaw B, Ayres AMJ* (1962) *J Org Chem* 27:281; [iii] *Eberson L* (1969) In: *Patai S (ed) Chemistry of carboxylic acids and esters*. Wiley, London; [iv] *Volke J, Liška F* (1994) *Electrochemistry in organic synthesis*. Springer, Berlin, pp 75–78

JL

Hoff, Jacobus Henricus van't

(© The Nobel Foundation)

(Aug. 30, 1852, Rotterdam, Netherlands – Mar. 1, 1911, Berlin-Steglitz, Germany) Dutch physical chemist. Educated in Delft as a technical chemist, he later studied physics and mathematics in Leiden. In 1872–74 he worked in the laboratories of A. Kekulé in Bonn (Germany) and of Ch. A. Wurtz in Paris. In 1876 he became a docent in Utrecht. Since 1878 van't Hoff was professor of chemistry, mineralogy, and geology at the University of Amsterdam (Netherlands). In 1896 he was elected to become a full (ordinary) member of the Prussian Academy of Sciences in Berlin and honorary Professor at the University of Berlin. This position allowed him to devote himself almost completely to research as his teaching load was small. In 1901 van't Hoff was the first recipient of the Nobel Prize in Chemistry for his contributions to chemical thermodynamics and for his discoveries concerning the osmotic pressure of solutions. Among his many contributions to chemistry are the derivation

RP

of the equations describing the temperature dependence of the equilibrium constant of a chemical reaction at constant pressure (van't Hoff's reaction isobar) and at constant volume (van't Hoff's reaction isochore), the discovery that the osmotic pressure in dilute solutions can be described by the same equation as the pressure of an ideal gas, and the tetrahedral model of carbon to understand optically active compounds. He was also the first to give equations for the temperature dependence of reaction rates, among which was what is now called the → *Arrhenius equation*.

Refs.: [i] <http://nobelprize.org/index.html>; [ii] Partington JR (1961) *A history of chemistry*, 4 vols. Macmillan, London; [iii] Laidler KJ (1993) *The world of physical chemistry*. Oxford University Press, Oxford, p 453; [iv] Laidler KJ (1985) *Arch Hist Exact Sci* 32:43; [v] Cohen E (1912) *Jacobus Henricus van't Hoff. Sein Leben und Wirken*. Akademische Verlagsgesellschaft, Leipzig

Hofmeister series — The Hofmeister series (HS) originates from the ranking of anions and cations toward their ability to precipitate a mixture of hen egg white proteins [i]. This protein precipitation can be explained simply in terms of the extent of ions binding to water (i.e., as a salting-out effect). The HS has been shown to have a much more general utility with a broad range of biophysical phenomena, which include the stability and crystallization of biological macromolecules, enzyme activity, DNA–protein interactions, etc. The traditional and extended HS [ii] is shown as

THE HOFMEISTER SERIES

KOSMOTROPIC STABILIZING DESTABILIZING CHAOTROPIC
(SALTING-OUT) (SALTING-IN)

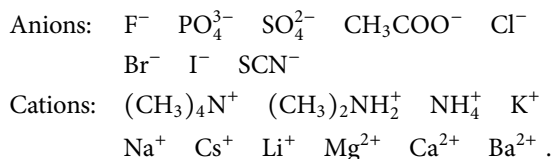

Ions in this series positioned to the left of Cl^- and Na^+ , known as water-structure makers or “kosmotropes”, exhibit stronger interactions with water molecules than water itself and most effective in precipitating proteins (“salting-out”). In contrast, the ions to the right side, known as water-structure breakers or “chaotropes”, exhibit weaker interactions with water than water itself and are most effective in solubilizing proteins (“salting-in”). Generally, however, the effect of cations on the protein precipitation or solubilization is less

remarkable than that of anions. It should also be noted that the HS has been reported in different ways, e.g., by adding/deleting some ions as occasion demands. In the field of electrochemistry, the HS is frequently used to discuss the selectivity of → *ion-selective electrodes* (particularly for anions [iii]). It is desirable to develop anion-selective electrodes that display an anti-Hofmeister selectivity sequence.

Refs.: [i] Kunz W, Henle J, Ninham BW (2004) *Curr Opin Colloid Interface Sci* 9:19; [ii] Cacace MG, Landau EM, Ramsden JJ (1997) *Quart Rev Biophys* 30:241; [iii] Wegmann D, Weiss H, Ammann D, Morf WE, Pretsh E, Sugahara K, Simon W (1984) *Microchim Acta (Wien)* 3:1

TO

Hole — When in → *semiconductors* and → *dielectrics* there is an → *electron* → *vacancy* this can be treated as a fictitious quasiparticle and it is called a hole. The effective → *charge* of a hole is positive.

FS

Ref.: [i] Elliott SR (1998) *The physics and chemistry of solids*. Wiley, Chichester

FS

HOMO — Acronym for “Highest Occupied Molecular Orbital”, which together with the → *LUMO* are called frontier orbitals. The HOMO corresponds to the highest molecular energy level occupied with electrons. These orbitals are important for determining materials characteristics because they are directly involved in electronic excitations caused, for example, by photon absorption. In the specific case of organic semiconductors, like conjugated molecules in the solid state, the delocalization of the π -electrons over the whole system causes a decrease in the energy gap between the HOMO and LUMO, so that increasing conjugation permits excitation by progressively lower frequency. HOMO–LUMO transitions promote electrons from HOMO to LUMO levels, creating holes in HOMO levels; both under the presence of an applied electric field may contribute to charge transport.

Ref.: [i] Levine IN (1991) *Quantum chemistry*. Prentice Hall, New Jersey

IH

Homoepitaxial metal deposition → *epitaxial metal deposition*

Homogeneous charge transfer reaction → *charge-transfer reaction*

Homogeneous chemical reactions in electrochemistry → *chemical reactions in electrochemistry*

HOPG → *graphite electrode*

Host — A → *molecular entity* that forms an → *inclusion complex* with organic or inorganic → *guests*, or a → *chemical species* that can accommodate guests within cavities of its crystal structure. Examples include cryptands and crowns (where there are → *ion-dipole interactions* between heteroatoms and positive ions), hydrogen-bonded molecules that form “clathrates” (e.g., hydroquinone and water), and host molecules of inclusion compounds (e.g., urea or thiourea). The → *van der Waals forces* and hydrophobic interactions (→ *hydrophobic effect*) bind the guest to the host molecule in clathrates and inclusion compounds.

Ref.: [i] Muller P (1994) *Pure Appl Chem* 66:1077

Horányi, György



(July 18, 1934, Budapest, Hungary – Sep. 3, 2006, Budapest, Hungary).

Horányi graduated in chemistry from the Eötvös Loránd University, Budapest in 1958 [i]. He developed an in situ radiotracer technique which is called thin-foil radiotracer method [ii, iii]. It has proved to be a very powerful tool for the investigation of → *electrosorption* and electrocatalytic phenomena at solid electrodes, ionic exchange processes in polymer-modified electrodes, and → *electrochemical oscillations* [ii–vi]. Although he remained in close contact with the university as a titular professor, in 1961 he joined the Central Research Institute for Chemistry of the Hungarian Academy of Sciences. Here beside the application of radiotracer labeling he studied many systems with traditional and other combined electrochemical techniques [vii–xi]. Some of his results are considered fundamental, e.g., the application of nickel oxide electrodes for the oxidation of organic species [viii–x], open-circuit electrochemical oscillations proving that the periodic changes are in connection with the nature of the electrochemical reactions and not with the electrical circuit [vii], reduction of perchlorate and nitrate ions, reductive splitting of C–OH

and C–Cl bonds [ix, x], the application of tungsten carbide as a hydrogenation catalyst [ix], the clarification of the properties of platinized platinum electrodes [x, xi]. He extended the application of radiotracer technique to the investigation of powered oxide surfaces. These studies contributed to a better understanding of the overall adsorption phenomena in the course of corrosion and constituted a link between electrochemistry and colloid chemistry [iii].

Refs.: [i] Inzelt G (2005) *J Solid State Electrochem* 9:245; [ii] Horányi G (1980) *Electrochim Acta* 25:45; [iii] Horányi G (2004) In: Horányi G (ed) *Radiotracer studies of interfaces*. Elsevier, Amsterdam, chapters 1,2,4,6; [iv] Horányi G (2002) *State of art: present knowledge and understanding*. In: Bard AJ, Stratmann M, Gileadi E, Urbakh M (eds) *Thermodynamics and electrified interfaces*. *Encyclopedia of electrochemistry*, vol. 1. Wiley-VCH, Weinheim, Chap. 3; [v] Horányi G (1999) *Radiotracer studies of adsorption/sorption phenomena at electrode surfaces*. In: Wieckowski A (ed) *Interfacial electrochemistry*. Marcel Dekker, New York, pp 477; [vi] Horányi G, Inzelt G (1978) *J Electroanal Chem* 87:423; [vii] Horányi G, Inzelt G, Szetey E (1977) *J Electroanal Chem* 81:395; [viii] Vértes G, Horányi G (1974) *J Electroanal Chem* 52:47; [ix] Horányi G (1994) *Catal Today* 19:285; [x] Horányi G (2003) *Electrocatalysis – heterogeneous*. In: Horváth IT (ed) *Encyclopedia of catalysis*, vol. 3. Wiley Interscience, Hoboken, pp 115–155; [xi] Inzelt G, Horányi G (2006) *The nickel group (nickel, palladium, and platinum)*. In: Bard AJ, Stratmann M, Scholz F, Pickett CJ (eds) *Inorganic chemistry*. *Encyclopedia of electrochemistry*, vol. 7a. Wiley-VCH, Weinheim, chap. 18

GI

Horiuti, Juro (Horiuchi J)



(Sep. 17, 1901, Sapporo, Japan – June 27, 1979, Sapporo, Japan) Horiuti's academic career began at the University of Tokyo. During his studies in Germany he started to work with → *Polanyi M* whom he followed to Manchester. They published together pivotal papers regarding electrode kinetics and heterogeneous catalysis, and they realized the inherent link between these areas [i–iv]. He returned to Sapporo as a professor of physical chemistry at Hokkaido University where he worked until his re-

tirement on the problems of catalysis and electrode processes. He introduced the concept of the \rightarrow *stoichiometric number* of the rate-determining step [v–viii].

Refs.: [i] Horiuti J, Polanyi M (1933) *Nature* 132:819, 132:931; [ii] Horiuti J, Polanyi M (1934) *Nature* 134:377; [iii] Horiuti J, Polanyi M (1935) *Acta Physicochim U.R.S.S.* 2:505; [iv] Horanyi G (2003) *J Molecular Catal* 199:7; [v] Horiuti J, Ikushima M (1939) *Proc Imp Acad Tokyo* 15:39; [vi] Horiuti J, Nakamura T (1967) *Adv Catal* 17:1; [vii] Erdey-Grúz T (1972) *Kinetics of electrode processes. Akadémiai Kiadó, Budapest*, pp 65–67; [viii] Aramata A (2003) *J Molecular Catal* 199:1

GI

Hot-wire electrodes \rightarrow *heated electrodes*

Howell cell — This was a variation of the \rightarrow *Leclanché cell*. See also \rightarrow *Daniell cell*, \rightarrow *zinc*, \rightarrow *Zn²⁺/Zn electrodes*, \rightarrow *Zn²⁺/Zn(Hg) electrodes*, \rightarrow *zinc–air batteries (cell)*.

Ref.: [i] Hauck WP (1883) *Die Galvanischen Batterien, Accumulatoren und Thermosäulen*, 2nd edn. Hartleben's Verlag, Wien

Hückel, Erich Armand Joseph



(Aug. 9, 1896, Berlin, Germany – Feb. 16, 1980, Marburg, Germany) From 1914 to 1921 Hückel studied physics and mathematics in Göttingen, where he received his Ph.D. in 1921 for a work on diffraction of X-rays by anisotropic liquids. That topic was given to him by \rightarrow *Debye*. Later he was assistant of \rightarrow *Born* in Göttingen and moved in 1922 to Debye in Zurich. Together with Debye he developed what is now known as the \rightarrow *Debye–Hückel theory* of strong electrolytes [i, ii]. In 1925 Hückel habilitated in Zurich with a thesis on strong electrolytes. In 1928 Hückel started to work as a Rockefeller scholar in the Institute of \rightarrow *Donnan* in London, and moved in 1929 to Copenhagen where he joined the institute of Niels Bohr. Bohr suggested that Hückel should try to apply the modern quantum mechanics to chemical problems, especially the double bonds of carbon. The development of the so-called “Hückel molecular orbital (HMO) theory” is regarded as his opus magnum. In 1929 Hückel

obtained a scholarship to work in Leipzig, where Debye was professor since 1927, and Heisenberg and Hund were also professors. In that fruitful environment he started to study the bonding theory of benzene, and developed his theory of aromaticity. After getting a teaching position at the University of Stuttgart he habilitated in 1931 with the work on benzene [iii]. In 1937 he became extraordinary Professor in Marburg, and in 1962 he became full Professor there. Erich Hückel was the brother of the well-known organic chemist Walter Hückel (1895–1973), and he was married to the daughter of \rightarrow *Zsigmondy*.

See also \rightarrow *Hückel equation of electrophoretic mobility*, \rightarrow *Debye–Hückel approximation*, \rightarrow *Debye–Hückel length*, \rightarrow *Debye–Hückel limiting law*, \rightarrow *Debye–Hückel–Onsager theory*, \rightarrow *Debye–Hückel parameter*.

Refs.: [i] Debye P, Hückel E (1923) *Phys Z* 24:185; [ii] Debye P, Hückel E (1923) *Phys Z* 24:305; [iii] Hückel E (1931) *Z Phys* 70:204

FS

FS

Hückel equation of electrophoretic mobility — The \rightarrow *electrophoretic mobility* μ_E of a particle with a rather thick \rightarrow *double layer*, i.e., for $\kappa r \ll 1$ (κ is the \rightarrow *Debye–Hückel parameter* and r is the particle radius) is as follows:

$$\mu_E = v/E = Q/6\pi r = (2\varepsilon_0 \varepsilon_r \zeta/3\eta) (1 + \kappa r) \approx 2\varepsilon_0 \varepsilon_r \zeta/3\eta$$

(Here v is the velocity of the particle, E is the electric field strength, ε_0 is the \rightarrow *permittivity of vacuum*, ε_r is the \rightarrow *dielectric constant* of the electrolyte solution, ζ is the equilibrium potential at the ‘plane of shear’ (\rightarrow *zeta potential*), and η is the \rightarrow *viscosity*. See also \rightarrow *Smoluchowski equation* (for the case of $\kappa r \gg 1$).

Refs.: [i] Hückel E (1924) *Phys Z* 25:204; [ii] Hunter RJ (2004) *Foundations of colloid science*, 2nd edn. Oxford University Press, Oxford, pp 380; [iii] Morrison ID, Ross S (2002) *Colloidal dispersions. Suspensions, emulsions, and foams*. Wiley Interscience, New York, pp 334

FS

Hull cell — The Hull cell is a trapezoidal cell (see Fig. 1) and is used for screening purposes of electrolytes. Due to the asymmetric shape the current varies over a wide range from the high current density (hcd) to the low current density (lcd) edge. Thus the effect of the current density can be checked by visual inspection of the cathode after the plating process. A typical cell volume is 250 ml. A useful formula for the estimation of the local current density is: $i/i_m = -2.33 \log(z) - 0.08$, where i_m is the average current density and z the normalized distance from the hcd edge.

AB

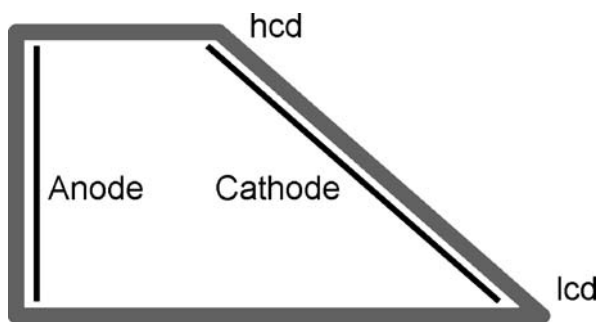

Hull cell — **Figure.** Schematic representation of the Hull cell

Hybrid ion \rightarrow zwitter ion

Hydrated electron — When a free electron is injected into water, it localizes in a cavity (electrostatic potential well) between two water molecules within less than 1 ps:

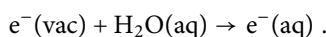

There it forms two slightly asymmetric H-bonds with neighboring water molecules, and survives for about 1 ms at pH 7. During its brief lifetime it exists in an s-like (near-spherical) ground state. After formation, the equivalent radius of the hydrated electron is about 200 pm. Ultimately it decomposes by reaction with a proton to create a hydrogen atom:

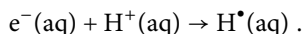

Electrochemically, “hydrated electrons” require ultra-negative electrode potentials for their formation in the dark (more negative than -2.87 V vs. SHE), corresponding to $+1.57$ V vs. a stationary electron in the vacuum [i]. Accordingly, they are not formed spontaneously in the conventional range of electrode potentials in water. The thermodynamic properties of hydrated electrons may be estimated by a \rightarrow *Born-Haber cycle*. Thus the Gibbs energy of hydration of the electron is $\Delta G_{\text{hyd}} \approx -149$ kJ mol $^{-1}$, the enthalpy of hydration of the electron is $\Delta H_{\text{hyd}} \approx -166$ kJ mol $^{-1}$, and the entropy of hydration of the electron is $\Delta S_{\text{hyd}} \approx -58$ J K $^{-1}$ mol $^{-1}$. Analogous to hydrated electrons, ammoniated electrons can be prepared in liquid ammonia. These are stable for several days, forming a characteristic blue solution.

Ref.: [i] Trasatti S (1986) *Pure Appl Chem* 58:955

SF

Hydrated ion — Ion associated with water molecules in aqueous solution. Since an ion has an electric charge, it

interacts with some water molecules by electrostatic interactions (e.g., \rightarrow *ion-dipole interaction*) and hydrogen bonding and forms a molecular group, i.e., a hydrated ion. This reaction is called \rightarrow *hydration*. The strength of hydration of ions increases in general with increasing the ionic valence and with decreasing the crystal ionic radius (e.g., $\text{K}^{+} < \text{Na}^{+} < \text{Li}^{+}$). Because hydrophilic ions become apparently larger, their hydration tends to decrease the ionic conductivity (\rightarrow *ionic conductors*) or \rightarrow *ionic mobility*. When strongly hydrophilic ions such as Li^{+} , Na^{+} , Ca^{2+} , Ba^{2+} , Cl^{-} , and Br^{-} are transferred from water to water-immiscible organic solvents, some water molecules hydrated to the ions are co-transferred to the organic phase [iii, iv]. Even water-immiscible organic solvents such as nitrobenzene usually dissolve a considerable amount of water (e.g., 0.168 M H_2O in nitrobenzene). In such “mixed” solvents, hydrophilic ions are selectively solvated with water. See also \rightarrow *ion*, \rightarrow *hydration number*.

Refs.: [i] Marcus Y (1985) *Ion solvation*. Wiley, Chichester; [ii] Marcus Y (1997) *Ion properties*. Marcel Dekker, New York; [iii] Osakai T, Ogata A, Ebina K (1997) *J Phys Chem B* 101:8341; [iv] Osakai T, Ebina K (2001) *Ion solvation and resolution*. In: Volkov AG (ed) *Liquid interfaces in chemical, biological, and pharmaceutical applications*. Marcel Dekker, New York, p 23

TO

Hydration

- (a) In chemical reactions is addition of water or of the elements of water (i.e., H and OH) to a \rightarrow *molecular entity*. For example, hydration of ethene:

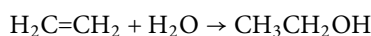

- (b) The term is also used in a more restricted sense for the process:

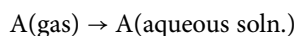

- (c) In solution chemistry the term is used to describe the state of the ions of an electrolyte in aqueous solution. See also \rightarrow *solvation*.

Ref.: [i] Muller P (1994) *Pure Appl Chem* 66:1077

WK

Hydration number — The number of solvent molecules in the immediate neighborhood of the ions can be regarded as the measure of primary \rightarrow *hydration*. In a narrower sense, this is the coordination number of hydration or hydration number. Usually, however, in a broader

sense of the word, hydration number means the assumed number of water molecules moving together with the ion required for the formal interpretation of the phenomena observed experimentally, when hydration is supposed to alter merely the size of ions as kinetic entities, leaving the medium unaltered [i]. Among the phenomena involved in the concept of hydration, the effect of the electric field of ions on the immediate neighboring dipole molecules of water is the predominating factor. According to the Born-theory [ii], the smaller the size (r_i radius) and the higher the charge of the ion (z_i), the more important this effect is, because the electric force at the “surface” of the ion is greater. Owing to the ion-dipole interaction partial or total dielectric saturation, increase of the \rightarrow *dielectric relaxation* time occurs. The number of water molecules whose rotation is hindered may also be a measure of the hydration number. Not surprisingly, the hydration numbers determined by various methods (water transport, diffusion, ion mobility, electrolyte activity, density compressibility, ultrasonic absorption, entropy measurements, etc.) differ, considerably [i]. However, the increase of the hydration number with the higher z_i and smaller r_i remains always true [iii–iv]. (See also \rightarrow *Born equation*, \rightarrow *hydrated ion*.)

Ref.: [i] Erdey-Grúz T (1974) *Transport phenomena in aqueous solutions*. Adam Hilger, London; [ii] Born M (1920) *Z Phys* 1:45; [iii] Komorosky-Lovrić Š (2002) *Electrolytes*. In: Scholz F (ed) *Electroanalytical methods*. Springer, Berlin, pp 287–290; [iv] Robinson RA, Stokes RH (1959) *Electrolyte solutions*. Butterworths, pp 52–71

Hydrazine — (NH_2NH_2) A chemical reagent with ammonia-like odor and strong reducing capacity. It is characterized by M_W of $32.045 \text{ g mol}^{-1}$; m.p. 1.4°C (1 atm); b.p. 113.55°C (1 atm). In liquid state it is colorless and fuming, while it forms white crystals in the solid state. It is very soluble in water where it reacts to produce basic solutions of hydrazine hydrate, $\text{N}_2\text{H}_4 \cdot \text{H}_2\text{O}$. In water, hydrazine hydrate is a dibasic reagent with $\text{p}K_{b,1} = 5.9$ and $\text{p}K_{b,2} = 15.0$ at 25°C [i]. Hydrazine can ignite spontaneously; it burns rapidly and produces a large amount of heat. It has been applied in many areas, such as \rightarrow *fuel cells* [ii], the synthesis of \rightarrow *nanoparticles* [iii], catalysts, herbicides, as well as a propellant of rockets [iv].

Breathing hydrazine may cause coughing and irritation of the throat and lungs. It is classified as a possible cancer-causing agent and prolonged exposure may lead to hepatorenal failure [v].

Refs.: [i] Lide DR (2005) *CRC handbook of chemistry and physics*, vol. 8. CRC Press, Florida, p 58; [ii] Yamada K, Yasuda K, Tanaka H,

Miyazaki Y, Kobayashi T (2003) *J Power Sources* 122:132; [iii] Solla-Gullón J, Rodes A, Montiel V, Aldaz A, Clavilier J (2003) *J Electroanal Chem* 554:273; [iv] Safavi A, Abdollahi H, Sedaghatpour F, Hormozi Nezhad MR (2003) *Talanta* 59:147; [v] Choudhary G, Hansen H (1996) *Chemosphere* 37:801

FG

Hydrodynamic boundary layer — is the region of fluid flow at or near a solid surface where the shear stresses are significantly different to those observed in bulk. The interaction between fluid and solid results in a retardation of the fluid flow which gives rise to a boundary layer of slower moving material. As the distance from the surface increases the fluid becomes less affected by these forces and the fluid velocity approaches the freestream velocity. The thickness of the boundary layer is commonly defined as the distance from the surface where the velocity is 99% of the freestream velocity. The hydrodynamic boundary layer is significant in electrochemical measurements whether the convection is forced or natural; the effect of the size of the boundary layer has been studied using hydrodynamic measurements such as the \rightarrow *rotating disk electrode* [i] and \rightarrow *flow-cells* [ii].

Refs.: [i] Mandin P, Pauporté T, Fanouillère P, Lincot D (2004) *J Electroanal Chem* 565(2):159; [ii] Shukla PK, Orazem ME, Nelissen G (2006) *Electrochim Acta* 51:1514

SM

Hydrodynamic electrodes — are electrodes where a forced convection ensures a \rightarrow *steady state* \rightarrow *mass transport* to the electrode surface, and a \rightarrow *finite diffusion* (subentry of \rightarrow *diffusion*) regime applies. The most frequently used hydrodynamic electrodes are the \rightarrow *rotating disk electrode*, \rightarrow *rotating ring disk electrode*, \rightarrow *wall-jet electrode*, wall-tube electrode, channel electrode, etc. See also \rightarrow *flow-cells*, \rightarrow *hydrodynamic voltammetry*, \rightarrow *detectors*.

Ref.: [i] Mount AR (2003) *Hydrodynamic electrodes*. In: Bard AJ, Stratmann M, Unwin P (eds) *Instrumentation and electroanalytical chemistry*. *Encyclopedia of electrochemistry*, vol. 3. Wiley-VCH, Weinheim, pp 134

FS

Hydrodynamic voltammetry — is a \rightarrow *voltammetry* technique featuring an electrolyte solution which is forced to flow at a constant speed to the electrode surface. \rightarrow *mass transport* of a redox species enhanced in this way results in higher current. The forced flow can be accomplished either by agitation of the solution (solution stirring, or channel flow), or the electrode (electrode rotation, see \rightarrow *rotating disk electrode* or vibration,

see → *sonoelectrochemistry*). Depending on the distance from the electrode surface, three regions of the solution flow can be distinguished, i.e., (i) a turbulent flow region comprising the bulk of the solution, (ii) a laminar flow region, situated closer to the electrode surface, composed of adjacent layers sliding by each other parallel to the electrode surface, and (iii) a stagnant-solution layer of thickness δ , called the → *Nernst layer*, in which the flow rate is decreased to zero due to frictional forces. A redox species is transported by a forced flow to the stagnant layer and then diffuses through this layer to the electrode surface. At potentials sufficiently negative to completely reduce an oxidized substrate, a steady-state limiting cathodic current is recorded in all hydrodynamic voltammetry techniques at a constant flow speed. Ref.: [i] Heineman WR, Kissinger PT (1996) *Large-amplitude controlled-potential techniques*. In: Kissinger PT, Heineman WR (eds) *Laboratory techniques in electroanalytical chemistry*, 2nd edn. Marcel Dekker, New York, pp 110; [ii] Mount AR (2003) *Hydrodynamic electrodes*. In: Bard AJ, Stratmann M, Unwin P (eds) *Instrumentation and electroanalytical chemistry*. *Encyclopedia of Electrochemistry*, vol. 3. Wiley-VCH, Weinheim, pp 134

WK

Hydrofluoric acid — (HF) A solution of hydrogen fluoride in water. The pure hydrogen fluoride is characterized by M_W of 20.0063 g mol⁻¹; m.p. -83.55 °C (1 atm); b.p. 19.5 °C (1 atm). When concentrated, this colorless fuming liquid is extremely corrosive and can dissolve almost all inorganic oxides such as silicate compounds or oxides of metals like stainless steel, aluminum, and uranium; however, it can be stored in casted iron bottles because a corrosion-resistant iron fluoride layer protects the metal. It is used for several purposes such as the preparation of titanium oxide nanotube arrays [i], silicon nanoparticles [ii] and electrochemical etching of silicon [iii], electrochemical deposition of lithium [iv], etc.

In dilute solutions HF_(aq) behaves as a weak acid with $pK_a = 3.20$. Contrary to ordinary weak acids, however, it becomes more and more dissociated with increasing concentration and is a considerable strong acid in pure state. This is because, irrespective of the concentration, hydrofluoric acid is mostly ionized in water. Nevertheless, the fluoride anion has strong tendency to form ion pairs like H₃O⁺ ⋯ F⁻ in dilute solutions. Provided the solution is more concentrated, the molecules of water that stabilize the ion pairs are replaced by the ions of dissociated HF, increasing the number of charged species [v].

It is an extremely toxic reagent that must be handled with extreme care. HF may cause little harm to outer

tissues but considerable damage to inner tissues, since it can penetrate tissues quickly and react later. Consequently, exposure to HF may not evidence symptoms during some hours, until the fluoride ions begin to react with calcium in the bones [vi].

Refs.: [i] Gong D, Grimes CA, Varghese OK, Hu W, Singh RS, Chen Z, Dickey EC (2001) *J Mater Res* 16:3331; [ii] Liu S, Sato S, Kimura K (2005) *Langmuir* 21:6324; [iii] Lehmann V, Foell H (1990) *J Electrochem Soc* 137:653; [iv] Kanamura K, Shiraishi S, Takehara ZI (1996) *J Electrochem Soc* 143:2187; [v] Giguère PA (1979) *J Chem Educ* 56:571; [vi] Hatzifotis M, Williams A, Muller M, Pegg S (2004) *Burns* 30:156

FG

Hydrogen absorption — A term used to describe the dissolution of hydrogen into a bulk liquid or solid phase.

This is in contrast with hydrogen → *adsorption* in which the molecules are only at the interface of two phases. Investigation of dissolution of hydrogen in solid phases is of special interest for hydrogen storage systems applicable, e.g., in → *fuel cells*. The high solubility of hydrogen in palladium is one of the oldest examples, reported by Graham [i]. The first examples that he studied were palladium and palladium-silver alloys. He also showed that hydrogen could be introduced into palladium and palladium silver alloys by electrochemical charging [ii]. The transfer of hydrogen from the gas phase into the lattice is composed of at least two steps. First, the dissociative chemisorption of H₂ molecules impinging on the surface, followed by the subsequent atomic diffusion of atomic hydrogen into and through the lattice. These steps are schematically represented by the following equations:

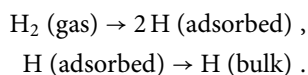

The most often used equation to describe the absorption of hydrogen is the Sievert relationship (Sievert's law):

$$c_{\text{H}} = K \sqrt{p_{\text{H}_2}} ,$$

where c_{H} is the concentration of hydrogen in the metal phase, K is the temperature-dependent equilibrium constant, and p_{H_2} is the partial pressure of hydrogen. For electrochemical charging and thermodynamic considerations [iii] see → *electrode materials (palladium)*; → *cold fusion*.

Refs.: [i] Graham T (1866) *Philos Trans R Soc London* 156:415; [ii] Graham T (1868) *Proc R Soc London* 16:422; [iii] Checchetto R, Trettel G, Miotello A (2004) *Meas Sci Technol* 15:127; Gabrielli C, Grand PP, Lasia A, Perrot H (2004) *J Electrochem Soc* 151:A1925; 151:A1937; 151:A1943

GH

Hydrogen adsorption → chemisorption of hydrogen

Hydrogen bond — is a form of association between an electronegative atom and a hydrogen atom attached to a second, relatively electronegative atom (→ *electronegativity*). It is best considered as an electrostatic interaction, heightened by the small size of hydrogen, which permits proximity of the interacting dipoles or charges. Both electronegative atoms are usually (but not necessarily) from the first row of the Periodic Table, i.e., N, O, or F. Hydrogen bonds may be intermolecular or intramolecular. With a few exceptions, usually involving fluorine, the associated energies are less than $20\text{--}25\text{ kJ mol}^{-1}$ ($5\text{--}6\text{ kcal mol}^{-1}$).

Ref.: [i] Muller P (1994) *Pure Appl Chem* 66:1077

Hydrogen electrode — A gas → *electrode* where purified hydrogen gas is dissolved, usually in an aqueous solution, in which an inert electrode, preferably a → *platinized platinum* (→ *platinum black*, → *electrode materials*) electrode is inserted. The hydrogen electrode is of exceptional importance in electrochemistry because the → *standard hydrogen electrode* (SHE) provides by convention a reference potential for all half reactions and thus the thermodynamic reference point for all energy calculations. An alternative form is the → *dynamic hydrogen electrode* (DHE).

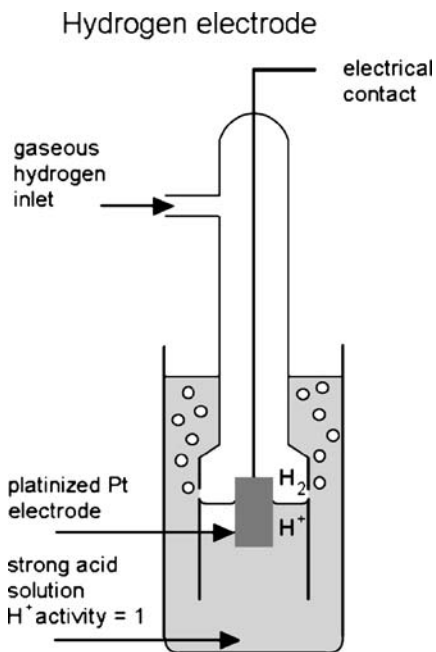

Hydrogen electrode — Figure

Refs.: [i] Sawyer D, Sobkowiak A, Roberts JL Jr (1995) *Electrochemistry for chemists*, 2nd edn. Wiley Interscience, New York; [ii] Inzelt G (2006) *Standard potentials* (chap. 1). *Platinum* (chap. 17.3). In: Bard AJ, Stratmann M, Scholz F, Pickett C (eds) *Inorganic chemistry. Encyclopedia of electrochemistry*, vol. 7a. Wiley-VCH, Weinheim; [iii] Kahlert H (2002) *Reference electrodes*. In: Scholz F (ed) *Electroanalytical methods*. Springer, Berlin, pp 263–264

MD

Hydrogen embrittlement → embrittlement

Hydrogen energy systems — refer to production, storage, delivery, and use of hydrogen as a fuel for “Hydrogen Economy”. The systems are being developed to overcome problems of use of the fossil fuels and to replace in the future those fuels by hydrogen produced from water using renewable sources of energy. Oxygen generated during hydrogen production is released to the atmosphere to balance for the oxygen used later, when it combines with the hydrogen, producing energy and water. Such systems produce virtually no contamination, no greenhouse gases, and no particulates. But there are many technical problems, especially with hydrogen generation. Renewable sources of energy (solar cells, wind or tide turbines, etc.) have low energy output, they are still more expensive per energy unit and cannot be placed everywhere. If the output of the energy source is in form of electric current, it is much more valuable than the hydrogen that can be produced from it. Despite very fast developments in the area that include very promising high temperature → *electrolysis* and thermochemical production, the methods of producing hydrogen from water are so far not very effective.

Storage and delivery of hydrogen may be done following pressurization or liquefaction, as gaseous hydrogen has low energy density per volume at atmospheric pressure. Both processes are energy intensive. As a small molecule, hydrogen tends to diffuse through the walls of the containers and cause the → *embrittlement* (weakening) of the container material. The same problem makes transmission of hydrogen difficult.

Hydrogen could be dangerous, because of its low density; it disperses in air much faster than common fuels. But this feature could also be advantageous when hydrogen leaks to air at open space locations: due to fast dispersion practically no explosive level of the hydrogen concentration is reached. Hydrogen economy is still a long-term goal, especially to make it economically sound. But as the oil prices rise many countries want to make its economies less oil dependent. There has been

growing interest in scientific research and fast technological developments in the area including electrochemical energy devices such as hydrogen – oxygen → *fuel cells*.

Refs.: [i] Lovins AB (2005) *Twenty hydrogen Myths*. Rocky Mountain Institute; [ii] United States Department of Energy (2002) *The national hydrogen energy roadmap*; [iii] United States Department of Energy (2002) *A national vision of America's transition to a hydrogen economy-to 2030 and beyond*; [iv] Bockris JO'M (2002) *Int J Hydrogen Energy* 27:731

PK

Hydrogen evolution reaction — [i–iii] is an → *electrode reaction* in which hydrogen gas is produced at the → *cathode* of an → *electrolysis cell* by the reduction of hydrogen ions or by the reduction of the water molecules of an aqueous solution. Abbreviated as “her”.

In acid solution the overall reaction is:

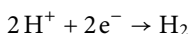

and in neutral and basic media:

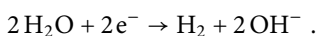

The electrochemical evolution of hydrogen has long been one of the most studied electrochemical processes. The mechanism of this process and the → *overpotential* depend on the electrode material. The → *Tafel equation* was formulated by → *Tafel* as an empirical relationship for the evolution of hydrogen. The electrocatalytic character of “her” follows from the marked dependence of the constants of the Tafel equation. According to the mechanistic interpretations the “her” consists of two steps, in the first of which adsorbed hydrogen is formed from the reactants (H_3O^+ or H_2O):

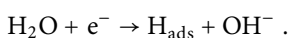
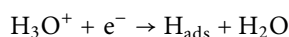

This process is often called the **Volmer reaction**. In the second step, adsorbed hydrogen is removed from the electrode, either in a chemical reaction

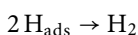

the **Tafel reaction** or in an electrode reaction (‘electrochemical desorption’).

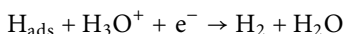

the **Heyrovský reaction**. The adsorbed hydrogen atom formed as intermediate plays a key role in the mechanism and kinetics of the “her”. In situ spectroscopic techniques and other methods such as → *cyclic voltammetry* give definitive evidence for the formation of adsorbed hydrogen atoms on some metals, particularly the

platinum metals. At such metals, the → *exchange current density* for H_2 evolution is relatively high. On other metals (e.g., Hg, Cd, and Hg), there is no evidence for adsorbed intermediates and the exchange current densities are low, i.e., a very large overpotential is needed in order to see significant H_2 evolution. Whatever the mechanisms are, the formation and then the cleavage of an M–H bond is involved. This means that while an increase in the free energy of adsorption will favor the formation of the adsorbed species, it will have the opposite effect on the second step in the overall process. Thus the maximum rate of hydrogen evolution will occur at intermediate values of metal-hydrogen bond strength, which leads to a significant, but not complete monolayer, coverage by adsorbed hydrogen atoms. A ‘volcano plot’ (→ *volcano curves*) of exchange current density vs. the free energy of hydrogen atom adsorption was found for a series of metal cathodes [iv, v]. (See also → *hydrogen electrode*, → *hydrogen energy system*.)

Refs.: [i] Koryta J, Dvořák J, Kavan L (1993) *Principles of electrochemistry*. Wiley, Chichester; [ii] Sawyer DT, Sobkowiak A, Roberts JL Jr (1995) *Electrochemistry for chemists*. Wiley, New York; [iii] Calvo EJ (1986) *Fundamentals. The basics of electrode reactions*. In: Bamford CH, Compton RG (eds) *Comprehensive chemical kinetics*, vol. 26. Elsevier, Amsterdam, pp 1–78; [iv] Conway BE (1999) *Electrochemical processes involving H adsorbed at metal electrode surfaces*. In: Wieckowski A (ed) *Interfacial electrochemistry, theory, experiment, and applications*. Marcel Dekker, New York, pp 131–150; [v] Savadogo O (1999) *Synergetic effects of surface active sites on the hydrogen evolution reaction*. In: Wieckowski A (ed) *Interfacial electrochemistry, theory, experiment, and applications*. Marcel Dekker, New York, pp 915–935

GH

Hydrogen ion exponent — Obsolete term for the numerical value of → *pH* used by → *Sørensen*.

Ref.: [i] Clark WM (1928) *The determination of hydrogen ions*. The Williams Wilkins Comp, Baltimore, p 37

FS

Hydrogen overpotential → *hydrogen evolution reaction*

Hydrogen overvoltage — This expression is sometimes used as a synonym of hydrogen overpotential, → *hydrogen evolution reaction*, however, this practice is discouraged.

GH

Hydrogen pumps — are electrochemical devices with proton-conducting → *solid electrolytes*, where → *hydrogen* is transported through a dense electrolyte membrane by an applied electrical field. The device

should comprise, at least, one membrane, two porous electronically-conducting → *electrodes* and current collectors. The applications include hydrogen separation and precise control of hydrogen → *activity*, which can be combined with electrocatalytic hydrogenation and dehydrogenation reactions, steam electrolysis, dehumidification, etc. Attractive potential applications are also the extraction of hydrogen isotopes and the synthesis of ammonia at atmospheric oxygen pressure. Significant → *proton mobility* is known for a great number of solid materials. A high proton conductivity at elevated temperatures is characteristic for oxide → *perovskites* derived from cerates, zirconates, and niobates of alkaline-earth elements. See also → *electrochemical gas compressors*.

Refs.: [i] Iwahara H, Asakura Y, Katahira K, Tanaka M (2004) *Solid State Ionics* 168:299; [ii] Schober T (2003) *Solid State Ionics* 162–163:277

VK

Hydrolysis — Generally, hydrolysis is a chemical reaction where a formal addition of a molecule of water at a substrate leads to a bond breaking (the reverse reaction is condensation).

In electrochemistry, hydrolysis often occurs as a follow-up reaction after an → *electron transfer*. Two basic types of hydrolysis can be distinguished: a) an intermediate or product of an electrochemical process bearing for example an electrochemically active C=N double bond (representing a substrate) undergoes an addition of water. The kinetics of the hydrolysis can be then followed directly using DC → *polarography* [i]; b) an intermediate or product of an electrochemical process (being, e.g., a strong nucleophile) can serve as a catalyst initiating (provoking) hydrolysis of an electrochemically inactive substrate dissolved in solution.

Ref.: [i] Ludvik J, Jirkovsky J, Urban J, Zuman P (1999) *J Agric Food Chem* 47:3879

Hydronium (H₃O⁺) activity → *pH*, and → *glass electrode*

Hydronium (H₃O⁺) ion → *water*, → *Eigen complex*, → *proton*, → *Zundel complex*

Hydrophilicity — The tendency of a molecule to be hydrated by water. The logarithm of the partition coefficient $\log(P)$ in the biphasic system octan-1-ol/water can be explored as a measure of the hydrophilicity of the molecules or a moiety [i]. The more negative value of $\log(P)$ means a higher hydrophilicity of the investigated compound. See also → *Hansch constant*.

Refs.: [i] Leo A, Hansch C, Elkins D (1971) *Chem Rev* 71:525; [ii] Testa B, van der Waterbeemd H, Folkers G, Guy R (2001) *Pharmacokinetic optimization in drug research*. Wiley-VCH, Weinheim, pp 275–304

RG

Hydrophobic effect — Effect that nonpolar compounds possess a low solubility in water. The reason for the low solubility is that nonpolar compounds when they dissolve in water destroy the water structure (hydrogen bonds) because of cavity formation, what is accompanied by a loss of entropy, and the water molecules are forced to order around the solute molecule (“iceberg” structure), which is a further loss of entropy. These entropy losses are not compensated for by formation of strong bonds between the solute and water, as it happens in case of polar molecules or esp. in case of ions.

Refs.: [i] Frank HS, Evans MW (1945) *J Chem Phys* 13:507; [ii] Tanford C (1973, 2nd edn. 1980) *The hydrophobic effect: formation of micelles and biological membranes*. Wiley, New York; [iii] Lazarides T (2001) *Acc Chem Res* 34:931

FS

Hypertonic → *osmosis*

JL **Hypotonic** → *osmosis*

Iceberg structure — Water molecules adjacent to an organic (nonpolar) liquid or solid phase and also adjacent to single hydrophobic molecules or hydrophobic parts of molecules are forming a shell-like structure via hydrogen bonding. Frank and Evans [i] have called this ‘iceberg structure’ because of its similarity with the structure of ice. This structure building is associated with a loss of entropy, and therefore that effect is partially responsible for the low solubility of nonpolar liquids in water, for → *micelle* formation, protein folding, etc. [ii]. See also → *hydrophobic effect*.

Refs.: [i] Frank HS, Evans MW (1945) *J Chem Phys* 13:507; [ii] Tanford C (1973, 2nd edn. 1980) *The hydrophobic effect: formation of micelles and biological membranes*. Wiley, New York

FS

Ideal nonpolarizable electrode — An electrode whose potential does not change upon passage of the current. Typical such electrodes with fixed potential are the → *reference electrodes*. See also → *electrode*.

Ref.: [i] Bard AJ, Faulkner LR (2001) *Electrochemical methods, 2nd ed.* Wiley, New York, p 22

JL

Ideal depolarized electrode — Working electrode in the situation, when electrolysis starts to occur and even a very small change of potential results in a large change of faradaic current (in the potentiostatic regime) or when the passing current does not cause the change of the potential (galvanostatic regime). The ideal nonpolarizability (depolarization) is characterized by the vertical part of the potentiostatic *I–E* curve or horizontal part of the galvanostatic *E–t* curve. (See also → *electrode*.)

JL

Ideal polarized electrode — Working electrode in the situation when a large change of potential is accompanied by an infinitesimal increase of the current. The ideal polarizability is characterized by a horizontal region of a potentiostatic *I–E* curve (so-called “potential window” where the electrode can be used for measurements). See also → *electrode*.

Ref.: [i] Bard AJ, Faulkner LR (2001) *Electrochemical methods, 2nd edn.* Wiley, New York, p 11

JL

Identity reaction — $A \rightarrow$ chemical reaction whose products are chemically identical with the reactants, e.g., the bimolecular self-exchange reaction of CH_3I with I^- .

Ref.: [i] Muller P (1994) *Pure Appl Chem* 66:1077

WK

IIR filter → *recursive filter*

Ilkovič, Dionýz



(Courtesy of Dr. M. Heyrovský, Prague)

(Jan. 18, 1907, Šarišský Štiavnik, Austro-Hungarian Empire, now Slovakia – Aug. 3, 1980, Bratislava, Czechoslovakia, now Slovakia). Ilkovič was assistant of → *Heyrovský, Jaroslav*, and from 1940 Professor of Physics at the Technical University of Bratislava, Slovakia. Ilkovič greatly contributed to the development of → *polarography*. He is particularly known for the → *Ilkovič equation* (1934), which describes the diffusion current at a → *dropping mercury electrode* [i, ii]. The Heyrovský–Ilkovič equation (1935) describes the entire current-potential curve (polarographic wave) [iii] of a reversible redox system in polarography, from which follows the definition of the polarographic → *half-wave potential*.

Ref.: [i] Ilkovič D (1934) *Coll Czech Chem Commun* 6:498; [ii] Ilkovič D (1938) *J Chim Phys* 35:129; [iii] Heyrovský J, Ilkovič D (1935) *Coll Czech Chem Commun* 7:198

EK

Ilkovič equation — The relationship between the concentration of an electrochemically active species at the electrode surface (*c*), inside the electrolyte solution (*c*₀), the flow of mercury at the dropping electrode (*m*), the number of electrons (*z*) transferred in the reduction step of the species under investigation and the current as a function of the time (during the life of a drop) under purely diffusional control *I*_{D,t} is

$$I_{D,t} = 0.732zFD^{1/2}m^{2/3}t^{1/6}(c - c_0).$$

This form already takes into account the change of the diffusion layer thickness during growth of the drop. At

sufficiently large overpotentials the surface concentration will drop to zero, thus the equation will be simplified:

$$I_{D,\text{lim}} = 0.732zFD^{1/2}m^{2/3}t_t^{1/6}c_0.$$

Mostly the average current (averaged over drop time t_t and thus drop size) is used:

$$\bar{I}_{D,\text{lim}} = 0.627zFD^{1/2}m^{2/3}t_t^{1/6}c_0.$$

A slightly varied form combines the constants into

$$\bar{I}_{D,\text{lim}} = 607zD^{1/2}m^{2/3}t_t^{1/6}c_0$$

(units: $D/\text{cm s}^{-1}$; $m/\text{g s}^{-1}$; t_t/s , $c/\text{mol cm}^{-3}$, $I/\mu\text{A}$).

See also → *Ilkovič*.

Refs.: [i] *Ilkovič D (1934) Coll Czech Chem Commun 6:498*; [ii] *Ilkovič D (1938) J Chim Phys 3:129*

RH

Image plane in double layer theory — In classical electrostatics a charge in front of a metal surface gives rise to an image charge on the metal, whose surface forms the image plane. In a real metal the effective image plane need not be identical to the metal surface, usually it lies a distance of the order of 0.5 \AA in front of it. The image plane is also the effective plate position of a metal capacitor. The electric → *double layer* can be viewed as a capacitor with an effective plate separation of a few Ångströms; hence a small shift of the image plane has a sizable effect on its capacity. The concept of the image plane has mostly been used in models in which the metal is represented as → *jellium model*.

Ref.: [i] *Schmickler W, Henderson D (1986) Prog Surf Sci 22:323*

WS

Imaginary part of impedance → *impedance*

Impedance — Symbol: Z , SI unit: Ohm (Ω) Impedance (or “complex impedance”) of an electrochemical system under study, Z , is defined on the basis of the passing → *alternating current*: $I = I_0 + I' \cos(\omega t + \varphi)$, at the same → *frequency*, ω , as the imposed sinusoidal perturbation of the electrode potential, $E = E_0 + E' \cos \omega t$, near a direct (average) potential bias, E_0 . Useful information on the system is given by two measured characteristics, the ratio of the amplitudes of the potential and current oscillations, E'/I' , and the phase difference (phase shift, or phase angle), φ (sometimes defined with an opposite sign). By definition, the impedance represents a complex quantity given by the formula: $Z = (E'/I') \exp(-i\varphi)$, i being the imaginary unit: $i = (-1)^{1/2}$. This complex quantity can be written down as a set of two real

quantities, e.g., $Z' = \text{Re } Z = (E'/I') \cos \varphi$ and $Z'' = \text{Im } Z = -(E'/I') \sin \varphi$ (called “real” and “imaginary part of impedance”, correspondingly), or $|Z| = (Z'^2 + Z''^2)^{1/2} = E'/I'$ and $\arg Z = \arctan(Z''/Z') = -\varphi$ (called “module” and “argument of impedance”). Another possibility is to represent this characteristic, Z , as a series or parallel combination of a resistance and a capacitance: $Z = R_s + (i\omega C_s)^{-1} = (R_p^{-1} + i\omega C_p)^{-1}$. These elements (which depend on the frequency, ω , in → *electrochemical impedance spectroscopy* measurements) can be expressed through the above characteristics, in particular the ratio, E'/I' , and the phase shift, φ . The conventional version of this technique requires several conditions to be satisfied: 1) The measurement is performed under equilibrium ($I_0 = 0$) or → *steady-state* ($I_0 \neq 0$) conditions; in the latter case (direct-current passage), all characteristics of the system (in particular, all concentration distributions) must be time-independent. 2) This state of the system must be stable, i.e., the intensity of the response to any external perturbation can be reduced to a sufficiently low level by the diminution of the amplitude of the perturbation. 3) The amplitude of the imposed sinusoidal perturbation of the electrode potential (or the passing current) should be so low that the induced current (potential variation) corresponds to linear response theory, i.e., the amplitudes, E' and I' , must be proportional to each other so that the measured impedance is independent of the perturbation intensity (a strong nonlinearity of the interfacial charging and faradaic current requires to diminish the amplitude by at least 10 mV, preferably within 5 mV). 4) The signal is only registered after reaching the regime of stabilized sinusoidal variation of both characteristics. The impedance measurement can be performed in the conventional three-electrode cell (→ *three-electrode system*). However, a nonsymmetrical geometry of the system results in deviations from the → *equivalent circuit* used for interpretation of the impedance plot, see → *Faraday impedance*. To minimize this effect one can use a two-electrode cell with a symmetrical configuration of electrodes, e.g., working electrode WE and counter/reference electrodes CE/RE as two parallel planes or a WE as a wire on the axis of a cylindrical CE/RE.

Refs.: [i] *Bard AJ, Faulkner LR (2001) Electrochemical methods, 2nd edn. New York*; [ii] *Macdonald JR (ed) (1987) Impedance spectroscopy. Emphasizing solid materials and systems. Wiley, New York*; [iii] *Retter U, Lohse H (2005) Electrochemical impedance spectroscopy. In: Scholz F (ed) Electroanalytical methods. Springer, Berlin, pp 149–166*; [iv] *Barsoukov E, Macdonald JR (ed) (2005) Impedance spectroscopy. Theory, experiment, and applications. Wiley, Hoboken*

MAV

Adsorption impedance — The current flowing in an electrochemical system splits into two parts at an interface: the charge either transfers across, (\rightarrow *faradaic current*) or gets accumulated at the two sides of the boundary (\rightarrow *non-faradaic* or \rightarrow *charging current*); the related impedance elements are called \rightarrow *Faraday impedance* and non-Faraday impedances, respectively. The latter element is an essentially capacitive element; its lossy character is related to the slow kinetics of \rightarrow *adsorption*-related processes involved.

Assume a metal-electrolyte interface; the capacitance of the interface is given as $C_{dl}(E) \equiv dq^M/dE$, where q^M is the electronic charge on the metal. This charge is balanced by the charge of species of the electrolyte, bound to the interface electrostatically or chemically. Thus, q^M depends on E at first directly, and then indirectly, through the surface excesses of the adsorbates, $\Gamma_i(E)$. That is, $q^M = q^M(E, \Gamma_i(E))$, and hence we can define interfacial capacity (\rightarrow *double layer*) in two ways: either by $C_{dl,r} = (\partial q^M/\partial E)_r$ or by $C_{dl} = dq^M/dE$. The first definition refers to a state which is frozen from the point of adsorption, whereas the second is the total capacity, i.e., when the capacitance is measured when the adsorbed species got in equilibrium at the given potential. Therefore, irrespectively of the impedance model of the interface, C_{dl} and $C_{dl,r}$ can be identified as $C_{dl}(\omega \rightarrow 0)$ and $C_{dl}(\omega \rightarrow \infty)$; the capacitance of adsorption is defined as their difference. The $C_{dl,r}$ term, with a given, constant adsorbate coverage, is usually interpreted as the electrostatic term of the \rightarrow *double-layer* capacitance, whereas the adsorption capacitance represents the potential dependence of the coverage; and as such, interpreted as the contribution of the chemically bound, not necessarily charged, species to the double-layer capacitance.

The lossy character of the adsorption impedance stems in the finite-rate response of coverages to potential changes: $\Gamma = \Gamma_i(E, t)$. Assuming one adsorption-desorption process, the adsorption-related current at a certain potential contains a $dq^M/dt = (\partial q^M/\partial \Gamma) \cdot d\Gamma/dt$ term; which, through the $d\Gamma/dt$ term, depends on the (eventually diffusion-controlled) kinetics of the adsorption process.

The detailed derivation leads to an impedance function, having an equivalent circuit where serially to the adsorption capacitance there are a resistance and a \rightarrow *Warburg impedance* [1]. Important points are as follows:

1. The adsorption capacitance is related to the potential dependence of the equilibrium surface excesses;

and thus, it is related to the thermodynamics of the adlayer.

2. The adsorption resistance is related to the potential dependence of the rate of adsorption proceeding to the actual, partially covered surface.
3. All terms include the $\gamma = (-1/F)(\partial q^M/\partial \Gamma)$ factor, the formal partial charge number, expressing the double-layer charging consequences of adsorption. Its generally non-zero value ensures that adsorption impedance can be measured even if the adsorbate is a noncharged species.
4. All three elements can scarcely be identified from impedance spectra of systems with adsorption; for example, in many cases the adsorption resistance is masked by the diffusional element. In addition, whenever electrodes of inhomogeneous surfaces (e.g., polycrystalline electrodes) are measured, the resistance-diffusional element – capacitance terms of the adsorption impedance are smeared out yielding a CPE-like impedance.

TP

Faraday impedance — The \rightarrow *impedance* of a conventional electrochemical cell is determined by a combination of contributions from the bulk solution and the interfaces of electrodes. For a symmetrical geometry of the system the WE surface is uniformly polarized even under conditions of an alternating current. Then, the cell impedance, Z , may be represented by a series combination of impedances of the bulk solution (a pure resistance, R_Ω , for not too high frequencies) and of the metal|solution interface (or two m|s interfaces for a two-electrode cell), $Z = R_\Omega + Z_{m|s}$. If the components of the solution are not electroactive at this m|s interface and the ion species cannot cross the interface (systems without \rightarrow *faradaic current*) the process at the interfaces is restricted to the charging of the electrical double layer characterized by a capacitance, C_{dl} , so that $Z_{m|s} = (i\omega C_{dl})^{-1}$. In contrast, if the electrochemical \rightarrow *double layer* EDL charging is accompanied by a faradaic current these two processes give parallel contributions into the interfacial impedance: $Z_{m|s} = (i\omega C_{dl})^{-1} + Z_F$ where the latter is called Faraday impedance.

For a system containing a solute redox couple reacting at the electrode surface, the faradaic current is controlled by two processes, the rate of the \rightarrow *charge transfer* step across the interface ($Ox + n e^- = Red$) and the transport of Ox and Red species to/from the electrode surface. In the conditions of a sinusoidal perturbation (\rightarrow *electrochemical impedance*) the latter process represents a dif-

fusion (in the presence of excess of a \rightarrow supporting electrolyte) or diffusion-migration (in systems without such electrolyte) across the nonstationary diffusion layer. Correspondingly, the total faradaic impedance is given by a series combination of the charge-transfer resistance and the \rightarrow Warburg impedance, $Z_F = R_{ct} + Z_w$. The overall impedance of the cell is given by the combination of all above formulas corresponding to the \rightarrow Randles-Erschler impedance circuit:

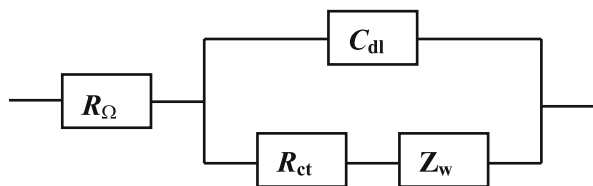

Impedance — Faraday impedance — Figure

The charge-transfer resistance for a simple one-step electrochemical reaction is given by the following equation:

$$R_{ct} = \frac{RT}{n^2 F^2 S k_s [(1 - \alpha) c_R(0) \times \exp((1 - \alpha)\varphi) + \alpha c_O(0) \exp(-\alpha\varphi)]}$$

The symbols $c_O(0)$ and $c_R(0)$ denote the concentrations of the reactant and product at the electrode surface, respectively, S is the electrode surface area, k_s is the \rightarrow standard rate constant, α is the \rightarrow transfer coefficient, $\varphi = nF(E - E^\ominus)/RT$ and n , F , R , T , and E^\ominus have their usual meanings.

The real and imaginary parts of Warburg impedance for the planar, semi-infinite \rightarrow diffusion are equal:

$$Z_w' = Z_w'' = \frac{\sigma}{\sqrt{\omega}}$$

$$\sigma = \frac{RT \exp(-\alpha\varphi) \left[\sqrt{D_O/D_R} \exp(\varphi) + 1 \right]}{n^2 F^2 \sqrt{2D_O} [(1 - \alpha) c_R(0) \times \exp((1 - \alpha)\varphi) + \alpha c_O(0) \exp(-\alpha\varphi)]},$$

where D_O and D_R are diffusion coefficients of the reactant and product and ω is the angular frequency.

At the \rightarrow equilibrium potential the parameters R_{ct} and σ are defined by \rightarrow Randles equations:

$$R_{ct,eq} = \frac{RT}{n^2 F^2 S k_s (c_R^*)^\alpha (c_O^*)^{1-\alpha}}$$

$$\sigma_{eq} = \frac{RT}{n^2 F^2 \sqrt{2}} \left[\frac{1}{c_R^* \sqrt{D_R}} + \frac{1}{c_O^* \sqrt{D_O}} \right],$$

where c_O^* and c_R^* are bulk concentrations of the reactant and the product.

In a more general case where the sinusoidal perturbation is imposed to a steady-state, concentration distributions due to a DC current passage (I_{DC}), the surface concentrations $c_O(0)$ and $c_R(0)$, are expressed as functions of the experimentally accessible variables c_O^* , c_R^* , and E using the diffusion layer theory:

$$I_{DC} = nFSD_R [c_R^* - c_R(0)] / \delta$$

$$I_{DC} = -nFSD_O [c_O^* - c_O(0)] / \delta$$

$$I_{DC} = nFSk_s [c_R(0) \exp((1 - \alpha)\varphi) - c_O(0) \exp(-\alpha\varphi)],$$

where δ is the diffusion layer thickness.

The same treatment is used if a reactant diffuses inside the liquid electrode (e.g., amalgam).

The above formulas may become inapplicable for systems with adsorption processes or/and coupled chemical steps in solution whose characteristic times are comparable with the inverse frequency within the impedance measurement interval. In this case the charge-transfer resistance, R_{ct} , must be replaced by a complex charge-transfer impedance, Z_{ct} . Another restriction of this treatment is its assumption of the uniform polarization of the m|s interface which requires to ensure a highly symmetrical configuration of the system.

Refs.: [i] Sluyters-Rehbach M, Sluyters JH (1970) Sine wave methods in the study of electrode processes. In: Bard AJ (ed) *Electroanalytical chemistry*, vol. 4. Marcel Dekker, New York, p 1; [ii] Bard AJ, Faulkner LR (2001) *Electrochemical methods*, 2nd edn. Wiley, New York; [iii] Retter U, Lohse H (2005) *Electrochemical impedance spectroscopy*. In: Scholz F (ed) *Electroanalytical methods*. Springer, Berlin, pp 149–166; [iv] Barsoukov E, Macdonald JR (ed) (2005) *Impedance spectroscopy*. Wiley, Hoboken

MAV, MLo

Gerischer impedance — The Gerischer impedance is a transport-related interfacial impedance element which differs from the Warburg impedance in that the electroactive species taking part in the electrode process is chemically generated in a spatially homogeneous way prior to diffusing to the interface. It has the form:

$$Z_G = \frac{\sigma \sqrt{2}}{\sqrt{i\omega + k}},$$

where σ is the coefficient of \rightarrow Warburg impedance and k is the homogeneous rate coefficient of the production of the electroactive species.

TP

Randles–Ershler impedance — An “equivalent circuit” named in honor of → *Randles* and Boris V. Ershler (1908–1978) [i–iii]. It consists of a parallel arrangement of a → *double-layer* capacitor and an interfacial → *impedance*, in series with a solution → *resistance*. Sometimes the interfacial impedance is further split into a series arrangement of a charge-transfer resistance and a → *Warburg impedance*. In general, equivalent circuits consist of ideal linear circuit elements in series, parallel, or even more complex arrangements. Typical elements include resistors, inductors, and capacitors. More rarely, Warburg impedances, → *transmission lines*, and → *constant phase elements* are also inserted. The principal significance of equivalent → *circuits* is that they provide a visual representation of the mathematical couplings between different interfacial processes. See also → *Randles semicircle*.

Refs.: [i] *Randles JEB (1947) Discuss Faraday Soc 1:11*; [ii] *Ershler BV (1947) Discuss Faraday Soc 1:269*; [iii] *Dolin P, Ershler BV (1940) Acta Phys Chim URSS 13:747*

SF

Warburg impedance — Warburg impedance is a transport-related interfacial impedance element; originated from the → *diffusion* of the electroactive species taking part in the electrode process. In general, the → *electrode processes* involves → *mass transport* of the species from and to the electrode surface; when calculating the impedance due to mass transport, the effects of diffusion, migration, and convection are to be considered. The Warburg impedance, with a characteristic $(i\omega)^{-1/2}$ frequency dependence (where *i* and ω stand for the imaginary unit and angular frequency, respectively) appears in the equivalent circuit of the electrode whenever diffusion to a planar interface affects the kinetics of the electrode process (of → *charge transfer*, or of → *adsorption*).

Consider a planar electrode on which some charge-transfer reaction proceeds. Let this electrode of area *A* be immersed in a quiescent electrolyte of a highly conducting, supporting electrolyte with a relatively low concentration of the electroactive species. The Warburg impedance is given as

$$Z_W = \frac{\sigma(1-i)}{\sqrt{\omega}} = \frac{\sigma\sqrt{2}}{\sqrt{i\omega}}$$

with

$$\sigma = \frac{1}{A} \frac{RT}{n^2 F^2 \sqrt{2}} \left(\frac{1}{\sqrt{D_{\text{ox}} c_{\text{ox}}^s}} + \frac{1}{\sqrt{D_{\text{red}} c_{\text{red}}^s}} \right),$$

where D_{ox} and D_{red} are the diffusion coefficients of the oxidized and reduced form of the electroactive species

whose surface concentrations are denoted by the c_{ox}^s and c_{red}^s ; *R*, *T*, *F*, and *n* stand for the → *gas constant*, absolute temperature, → *Faraday constant*, and number of electrons transferred, respectively.

Four important aspects need mentioning:

1. In general, the frequency dependence of the diffusional impedance and the geometry of diffusion are correlated. The $(i\omega)^{-1/2}$ frequency dependence corresponds to the semi-infinite planar diffusion; such a frequency dependence is valid only if the characteristic length, $(D/\omega)^{1/2}$ of diffusion is much shorter than any size of the electrode or the thickness of the electrolyte layer from which diffusion proceeds. Otherwise spherical, or bounded diffusion with different frequency dependence is observed.
2. In case of → *reversible systems* surface concentrations are determined by the electrode potential through the → *Nernst equation*; thus $\sigma(E)$ can be given as function of the c_{ox}^b and c_{red}^b bulk concentrations:

$$\begin{aligned} \sigma(E) &= \frac{1}{A} \frac{RT}{n^2 F^2 \sqrt{2}} \\ &\quad \times \frac{4 \cosh^2(nF(E - E_{1/2})/2RT)}{(c_{\text{ox}} \sqrt{D_{\text{ox}}} + c_{\text{red}} \sqrt{D_{\text{red}}})} \\ &= \frac{dm(E)}{dE}, \end{aligned}$$

where $E_{1/2}$ is the → *half-wave potential*, and the $m(E)$ is the semiintegrated current (→ *semiintegration*). This is how diffusion is represented by two interrelated perturbation-invariant response functions: by the Warburg coefficient and by the semiintegrated current characterizing the small-signal and large-signal responses, respectively.

3. The $(i\omega)^{-1/2}$ frequency dependence appears also in the impedance function of unsupported systems, that is, when the transport of the electroactive species proceeds via coupled diffusion and migration.
4. The Warburg impedance is sometimes modeled by RC ladder networks having impedance of $(i\omega)^{-1/2}$ frequency dependences. However, such modeling is somewhat misleading, due to the different underlying physics.

Impedance converters → *operational amplifier*

Immiscible liquid electrolytes → *interface between two immiscible electrolyte solutions*

Immiscibility polarization — Several solid compounds exhibit a partial immiscibility between their oxidized and reduced forms, usually due to structural dissimilarity of the oxidized and reduced phases. For an insertion electrochemical reaction $\{\text{Ox}\}_{\text{solid}} + e^- + \text{Cat}_{\text{solution}}^+ \rightleftharpoons \{\text{Cat}^+, \text{Red}\}_{\text{solid}}$, a miscibility gap between the oxidized and reduced phases gives rise to an inert region in → *voltammograms* because for a certain range of ratios of $a_{\{\text{Ox}\}_{\text{solid}}}/a_{\{\text{Cat}^+, \text{Red}\}_{\text{solid}}}$, no mixed crystals (solid solutions) exist, which would correspond to the electrode potential. In cyclic voltammograms, a miscibility polarization leads to a more or less large peak separation [i, ii], and the current peaks will in experiments show typical → *nucleation-growth* features [ii, iii]. When the two phases that enclose the miscibility gap have a sharp interface, additional concentration barriers can build up giving rise to unusual current spikes [ii] that have been experimentally observed, e.g., for a solid squaraine compound on electrodes [iv]. See also [v].

Refs.: [i] Scholz F, Lovrić M, Stojek Z (1997) *J Solid State Electrochem* 1:134; [ii] Lovrić M, Hermes M, Scholz F (2000) *J Solid State Electrochem* 4:394; [iii] Bond AM, Fletcher S, Symons PG (1998) *Analyst* 123:1891; [iv] Takeda N, Stawasz ME, Parkinson BA (2001) *J Electroanal Chem* 498:19; [v] Scholz F, Schröder U, Gulaboski R (2005) *Electrochemistry of immobilized particles and droplets*. Springer, Berlin

MHer

Immittance — In alternating current (AC) measurements, the term immittance denotes the electric → *impedance* and/or the electric → *admittance* of any network of passive and active elements such as the resistors, capacitors, inductors, constant phase elements, transistors, etc. In → *electrochemical impedance spectroscopy*, which utilizes equivalent electrical circuits to simulate the frequency dependence of a given electrochemical process or electrical double-layer charging, the immittance analysis is applied.

Both the impedance Z and admittance Y are complex functions defined by:

$$Z = R + iX$$

$$Y = G + iB,$$

where R is the resistance, X the reactance, G the conductance, B the susceptance, and $i = \sqrt{-1}$. The relationship between the impedance and admittance is given by:

$$Y = 1/Z.$$

Also the admittance modulus:

$$|Y| = \sqrt{R^2 + X^2}$$

and the impedance modulus:

$$|Z| = \sqrt{G^2 + B^2}$$

are related to each other by the reciprocal dependence: $|Y| = 1/|Z|$. However, the conductance G is not, in general, the reciprocal of resistance R . The same concerns to the reactance X and susceptance B .

The selection of impedance or admittance for presentation of experimental results and data analysis is dependent on the type of equivalent electric circuit. For instance, for the analysis of → *charge-transfer* processes and → *double-layer* charging, the impedance may be preferred, while for the resonance circuits (e.g., in piezometric systems) the admittance may offer advantages.

The immittance analysis can be performed using different kinds of plots, including complex plane plots of X vs. R for impedance and B vs. G for admittance. These plots can also be denoted as Z'' vs. Z' and Y'' vs. Y' , or $\text{Im}(Z)$ vs. $\text{Re}(Z)$, and $\text{Im}(Y)$ vs. $\text{Re}(Y)$. Another type of general analysis of immittance is based on network analysis utilizing logarithmic Bode plots of impedance or admittance modulus vs. frequency (e.g., $\log|Y|$ vs. $\log \omega$) and phase shift vs. frequency (ϕ vs. $\log \omega$). Other dependencies taking into account specific equivalent circuit behavior, for instance, due to diffusion of reactants in solution, film formation, or electrode porosity are considered in → *electrochemical impedance spectroscopy*.

Refs.: [i] Macdonald JR (1987) *Impedance spectroscopy*. Wiley, New York; [ii] Jurczakowski R, Hitz C, Lasia A (2004) *J Electroanal Chem* 572:355

MHep

Immunoassays, electrochemical — A quantitative or qualitative assay based on the highly selective antibody-antigen binding and electrochemical detection. Potentiometric, capacitive, and voltammetric methods are used to detect the immunoreaction, either directly without a label or indirectly with a label compound. The majority of electrochemical immunoassays are based on → *voltammetry* (→ *amperometry*) and detection of redox-active or enzyme labels of one of the immunochemical reaction partners. The assay formats are competitive and noncompetitive (see also → *ELISA*).

In enzyme electrochemical immunoassays the antigen or a second antibody is labeled with an enzyme that catalyzes the production of an electrochemically detectable product and the rate of the product formation is taken to quantify the antigen.

If the reaction is performed on a sensor it is called immunosensor or immunoelectrode (\rightarrow biosensor).

Refs.: [i] Brezer B, Radcliffe EJ (1951) *Nature* 167:79; [ii] Heineman WR, Halsall HB (1985) *Anal Biochem* 57:1321; [iii] Green MJ, Barrance DJ, Hilditch PI (1991) *Electrometric immunoassay*. In: Price C, Newman LJ (eds) *Principle and practice of immunoassay*. Macmillan, London, pp 135; [iv] Wijayawardhana CA, Halsall B, Heineman WR (2002) *Electrochemical immunoassay*. In: Bard AJ, Stratmann M, Wilson GS (eds) *Bioelectrochemistry. Encyclopedia of electrochemistry*, vol. 9. Wiley-VCH, Weinheim, pp 145; [v] Warsinke A, Benkert A, Scheller F (2000) *Fresenius J Anal Chem* 366:622

UW

Immunoelectrode \rightarrow immunoassay, electrochemical

Immunosensor \rightarrow immunoassay, electrochemical

Impinging-jet electrode (or stagnation-point electrode) — is a disk \rightarrow electrode of radius R embedded on an insulating plate in the stagnation region of a circular jet discharged from a nozzle of diameter d . The jet is submerged in a stationary electrolyte. The electrode is normal and axial to the jet direction. The electrode diameter is smaller than that of the jet, $2R < d$. This geometry results in a high \rightarrow mass transport rate.

The cathodic limiting current equation is, $I_L^- = 0.850nFAc_0D_O^{2/3}\nu^{-1/6}(v/l)^{1/2}$, where A is electrode surface area, m^2 ; c_0 concentration of oxidized species, $mol\ m^{-3}$; ν kinematic viscosity of solution, $m^2\ s^{-1}$; v linear liquid flow speed, $m\ s^{-1}$; $l = \pi R/2$.

The electrode is uniformly accessible to the diffusing ions within dimensionless electrode radius, $0.1 \leq R/d \leq 1.0$, for turbulent nozzle flow and, $0.1 \leq R/d \leq 0.5$, for laminar nozzle flow. Within the region of uniform accessibility, the mass transport rate is relatively independent of the electrode size in both laminar and turbulent flow for $0.2 \leq H/d \leq 6$, where H is the nozzle-to-plate distance. Beyond the region of uniform accessibility, the mass transfer rate decreases with the radial distance. In the intermediate range, $1 < R/d < 4$, the turbulent impinging jet changes from the stagnation flow to the wall-jet flow and for $R/d \geq 4$ the wall-jet flow predominates (\rightarrow wall-jet electrode).

Refs.: [i] Matsuda H (1967) *J Electroanal Chem* 15:109; [ii] Chin DT, Tsang CH (1978) *J Electrochem Soc* 125:1461

WK

Inclusion compound (or inclusion complex) — A complex in which one component, the host, forms a cavity or, in the case of a crystal, a crystal lattice containing spaces in the shape of long tunnels or channels in which

\rightarrow molecular entities of a second \rightarrow chemical species (the \rightarrow guest) are located. There is no covalent bonding between guest and host, the attraction being generally due to \rightarrow van der Waals forces. If the spaces in the host lattice are enclosed on all sides so that the guest species is “trapped” as in a cage, such compounds are known as “clathrates” or “cage compounds”.

Ref.: [i] Muller P (1994) *Pure Appl Chem* 66:1077

WK

Indicator

- in titrimetry: A reagent used to give an observable physical change at or near the \rightarrow equivalence point. Typical reagents that are used as indicators involve a change in color or the appearance or disappearance of turbidity [i]. There are also instruments to indicate the \rightarrow end point of a \rightarrow titration that respond to certain properties of the solution, such as conductivity, potential, temperature, etc., and whose readings vary in a characteristic way at or near the equivalence point [ii].
- in catalymetry: A kind of reagent whose reaction is catalyzed by the \rightarrow analyte and the resulting \rightarrow reaction rate can be readily measured by a given method. Thus, conditions are provided in such a way that the concentration of the analyte can be determined from the \rightarrow reaction rate data of the indicator [iii].

Refs.: [i] Bishop E (1972) *Indicators*. Pergamon, Oxford; [ii] Harris D (2002) *Quantitative chemical analysis*. WH Freeman, New York; [iii] Skoog D, West D, Holler F (1996) *Fundamentals of analytical chemistry*. Saunders College Publishing, New York

FG

Indicator electrode — In \rightarrow potentiometry the electrode for which the \rightarrow potential is recorded, in \rightarrow amperometry the electrode for which the \rightarrow current is recorded.

FS

Indirect and direct electrolysis — Electrolysis is the oxidation or reduction reaction caused by the current flowing through the cell. Direct electrolysis is a \rightarrow heterogeneous process and the \rightarrow electron transfer proceeds directly from the electrode to the molecule of the substrate. In the case of indirect electrolysis the \rightarrow mediator is necessary, which is first heterogeneously reduced (oxidized) at the electrode and then the electron transfer to/from the molecule of the substrate occurs in homogeneous conditions in the bulk of the solution. The intermediate

form of the mediator should be stable enough to diffuse from the electrode and to encounter the molecule of the substrate. The typical mediator is able to form a \rightarrow redox couple and thus it functions as a single-electron donor/acceptor.

JL

Induced adsorption — Enhancement of the \rightarrow adsorption of a component induced by another adsorbed species. These phenomena are treated in terms of induced anion and cation adsorption. Interrelation of anionic \rightarrow specific adsorption and \rightarrow underpotential deposition of metal ions is a typical example for the induced adsorption of anions [i].

Radiotracer adsorption studies (\rightarrow tracer methods) furnish information on this latter phenomenon by the use of labeled anions at low concentration in the presence of a great excess of supporting electrolyte containing the metal ion forming the \rightarrow adatoms [ii].

Refs.: [i] Horányi G (2002) *Specific adsorption. State of art: present knowledge and understanding*. In: Bard AJ, Stratmann M, Gileadi M, Urbakh M (eds) *Thermodynamics and electrified interfaces*. *Encyclopedia of electrochemistry*, vol. 1. Wiley-VCH, Weinheim, pp 349–382; [ii] Horányi G (2004) In: Horányi G (ed) *Radiotracer studies of interfaces*. *Interface science and technology*, vol 3. Elsevier, Amsterdam, p 54

GH

Induction period — The initial slow phase of a chemical reaction which later accelerates. Induction periods are often observed with radical reactions, but they may also occur in other systems (for example, before steady-state concentration of the reactants is reached).

Ref.: [i] Muller P (1994) *Pure Appl Chem* 66:1077

WK

Inductive effect — is an effect of the transmission of charge through a chain of atoms by electrostatic induction on rates of reaction, etc. A theoretical distinction may be made between the field effect, and the inductive effect as models for the Coulomb interaction between a given site within a \rightarrow molecular entity and a remote unipole or \rightarrow dipole within the same entity. The experimental distinction between the two effects has proved difficult, except for molecules of peculiar geometry, which may exhibit “reversed field effects”. Typically, the inductive effect and the field effect are influenced in the same direction by structural changes in the molecule and the distinction between them is not clear. Therefore, the field effect is often included in the term “inductive effect”. Thus, the separation of σ values (see \rightarrow electronic effect) into inductive and resonance components does

not imply the exclusive operation of a through-bonds route for the transmission of the nonconjugative part of the substituent effect. To indicate the all-inclusive use of the term inductive, the phrase “so-called inductive effect” is sometimes used. Certain modern theoretical approaches suggest that the “so-called inductive effect” reflects a field effect rather than through-bonds transmission.

Ref.: [i] Muller P (1994) *Pure Appl Chem* 66:1077

WK

Inert — Stable and unreactive under specified conditions.

Ref.: [i] Muller P (1994) *Pure Appl Chem* 66:1077

WK

Inert electrode — An \rightarrow electrode that does not take part in the \rightarrow electrode reaction but serves only as a source or sink of electrons. Thus the inertness of an electrode strongly depends on the experimental conditions, and there is no absolute and always inert electrode. In many instances electrodes made of noble metals, e.g., \rightarrow platinum, \rightarrow gold, \rightarrow mercury, or \rightarrow carbon (subentries of \rightarrow electrode materials) behave as (almost) inert electrodes.

BM

Inert electrolyte — An \rightarrow electrolyte that does not take part in any reaction but is only added to a solution to increase the \rightarrow conductivity. It is also called supporting electrolyte. The inertness of an electrolyte is always subject to the experimental conditions, e.g., \rightarrow electrode potential, \rightarrow electrode material, temperature, etc., and there is no universally inert electrolyte.

BM

Indium tin oxide (ITO) optically transparent electrode — An indium tin oxide (ITO) optically transparent electrode consists of a thin film of semiconducting tin-doped indium oxide $((\text{In}_2\text{O}_3)_x(\text{SnO}_2)_{1-x})$ coated onto a glass, quartz, or plastic substrate [i, ii]. Such an “optically transparent electrode” (OTE) is a prerequisite for spectroelectrochemical transmission measurements in the UV/visible region [iii, iv]. See \rightarrow spectroelectrochemistry. In addition to fundamental spectroelectrochemical studies, indium tin oxide (ITO) optically transparent electrodes see applications in liquid crystal displays, electrochromic devices, organic light emitting diodes (OLED), and in the development of photovoltaic devices. ITO is a “controlled band-gap material”, an increase of the Sn(IV) content having several important

effects [i]: the semiconductor band gap is shifted towards the ultraviolet, the luminous transmittance remains high, the infrared reflectance increases to a high value beyond a certain wavelength which shifts towards the visible, phonon-induced infrared absorption bands vanish, the microwave reflectance goes up, and the dc resistivity drops. A resistivity of $\sim 1 \times 10^{-4} \Omega \text{ cm}$ is often quoted as a number characteristic of an optimized ITO film [ii].

Refs.: [i] Hamberg I, Granqvist CG (1986) *J Appl Phys* 60:R123; [ii] Granqvist CG, Hultåker A (2002) *Thin Solid Films* 411:1; [iii] Mortimer RJ (1999) *Electronic spectroscopy: Spectroelectrochemistry, methods and instrumentation*. In: Lindon JC, Tranter GE, Holmes JL (eds), *Encyclopedia of spectroscopy and spectrometry*. Academic Press, London, pp 2174–2181; [iv] Bard AJ, Faulkner LR (2001) *Electrochemical methods*, 2nd edn. Wiley, New York, Chap. 17

RJM

Infinite impulse response filter → *recursive filter*

Infrared spectroscopy → *spectroscopy*

Inhibition — is a decrease in the reaction rate caused by a substance (→ *inhibitor*) affecting the concentration of a reactant, catalyst, or reaction intermediate. For example, molecular oxygen and *p*-benzoquinone can react as inhibitors in many reactions involving radicals as intermediates by virtue of their ability to act as scavengers toward these radicals. If the rate of a reaction in the absence of inhibitor is v_0 and that in the presence of a certain amount of inhibitor is v , the degree of inhibition, i , is given by

$$i = (v_0 - v)/v_0 .$$

Inhibition in electrochemistry is the decrease of the rate of the electrode process under influence of inhibitor that is adsorbed on the electrode surface. In the presence of inhibitor, the rate constant of the electrode process is expressed by

$$k = k_{\theta=0} (1 - \theta)^{r^*} \exp(A\theta) ,$$

where $k_{\theta=0}$ is the rate constant in the absence of inhibitor, A and θ is surface area and surface coverage, respectively, and r^* is the number of solvent molecules (associates) removed from the electrode surface by one molecule of the activated complex.

Refs.: [i] Muller P (1994) *Pure Appl Chem* 66:1077; [ii] Parsons R (1969) *J Electroanal Chem* 21:35; [iii] Parsons R (1970) *Ann Univ Ferrera Ser V, Suppl* 5/3

WK

Inhibitor (of an electrode reaction) — is a substance that added to the electrolyte solution causes a decrease in the rate of an electrochemical process by a physical, physicochemical, or chemical action and, generally, by modifying an electrode surface. This modification is due to adsorption of the inhibitor. The inhibitor may play no direct role in the electrochemical reaction or it can be a reaction intermediate.

A corrosion inhibitor may (a) decrease the rate of the cathodic or anodic process per apparent unit area by simply blocking active redox sites on the metal surface, (b) remove electrons from the metal thereby shifting the potential of the metal surface into a positive range of passivation, in which a metal oxide film is spontaneously formed, or (c) contribute to the formation of a thin protective coat on the surface, which stifles corrosion.

WK

Inner electric potential → *potential*, subentry → *inner electric potential*

Inner-sphere (electron transfer) — is, historically, an → *electron transfer* between two metal centers sharing a ligand or atom in their respective coordination shells. The term was then extended to any case in which the interaction energy between the donor and acceptor centers in the → *transition state* is significant ($>20 \text{ kJ mol}^{-1}$). See also → *Marcus theory*.

Ref.: [i] Muller P (1994) *Pure Appl Chem* 66:1077

WK

Inner electric potential → *potential*

Input impedance — Any measurement instrument, which can be represented as a combination (connected in series) of the actual measurement device and a resistor R_i representing the input impedance, connected with an electrochemical cell draws a current from this cell:

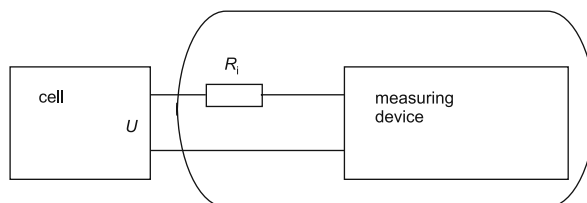

Input impedance — Figure

The value depends on the voltage and R_i (the input impedance). In an ideal case (→ *electrometer amplifier*, → *voltage follower*) R_i is very large resulting in an input

current U/R_i approaching zero. Thus the error caused by the current drawn from the cell vanishes. The actual input impedance of an instrument can be determined by measuring the cell voltage at various values of an additional resistor inserted between the cell and the instrument. At high values of input impedance even at large values of the additional resistor no significant deviation of the observed voltage will occur. Only when the value of the external resistor approaches the value of R_i deviations will become noticeable.

RH

Insertion electrochemistry — A branch of solid-state electrochemistry dealing with the electrochemical behavior of \rightarrow *insertion electrodes*.

These electrodes consist of a one-, two-, or three-dimensional lattices (frameworks) of an inorganic (or organic) host material with initially unoccupied cavities (sites). These sites can be occupied in an electrochemically controlled manner by guest ions, exhibiting a potential-dependent concentration in the electrode bulk and showing, in addition, a certain degree of mobility in the framework of the host. Since insertion electrodes are electrically neutral, the host material should also provide the sites for a concomitant insertion of electronic species. In transition metal oxides, for example, a localized electronic description is appropriate, so that the intercalation of Li-ions changes the valence of the transition metal. On the other hand, the insertion of anions or cations into the framework of π -conjugated oligomers or polymers results first in the appearance of single polaronic levels, which transform quickly into continuous polaronic or bipolaronic bands. Despite the difference in the electronic conductivity of the above-mentioned hosts, both of them are mixed electronic-ionic \rightarrow *conductors*, which is an essential feature of any insertion compound.

Historically, \rightarrow *graphite* intercalation compounds allowing for insertion cations, anions, and even large neutral molecules, have been intensively studied since the 1970s. Since then, there has been rapid progress in understanding the mechanisms of cation insertion (especially Li cations) into hard disordered \rightarrow *carbons*, artificially designed carbons such as fullerenes, and single- and multi-wall carbon nanotubes, etc. A great many transition metal oxides, sulfides, and mixed transition metal oxides were characterized for the purpose of searching for the effective reversible cathodes for Li-ion insertion. In recent years, there has been considerable interest in finding a reversible cathode for multi-cation insertion, and Mg ions, molybdenum sulfides and se-

lenides (Chevreton phase compounds) in particular were shown to perform excellently. In parallel to insertion compounds of an inorganic nature, another family of insertion materials based on π -conjugated oligomers and polymers has been intensively studied since the 1970s, e.g., oligo- and poly(phenylenes or thiophenes), \rightarrow *polypyrrole*, \rightarrow *polyaniline*, etc.

From a fundamental point of view, insertion electrochemistry deals with the thermodynamics and kinetics of intercalation processes starting at the electrode-solution and current collector-electrode interfaces, and occurring (propagating) into the electrode's interior. Very often (but not mandatory) intercalation processes into host electrodes occur in the form of first-order phase transition, and thus the classical galvanostatic charging of the electrode can be beneficially combined with simultaneous *in situ* XRD characterization. The latter allows the distinction between solid-solution and the two-phase coexistence paths of the intercalation process.

Although electrochemical characterizations have recently been performed on single intercalation particles, in most cases composite powdery electrodes containing a mixture of intercalation particles, electrically conductive additives (e.g., carbon black) and PVDF binder have also been used. In order to obtain consistent results and to reach comprehensible intercalation mechanisms in these electrodes, basic electroanalytical characterizations such as slow-scan rate \rightarrow *cyclic voltammetry* (SSCV), \rightarrow *potentiostatic intermittent titration* (PITT) (or \rightarrow *galvanostatic intermittent titration*, GITT), and \rightarrow *electrochemical impedance spectroscopy* (EIS) should be applied in parallel or in a single study.

Slow galvanostatic charging, SSCV, and one of the incremental titration techniques (PITT or GITT) provide valuable information on the experimental charge, Q , vs. potential, E , or differential intercalation capacitance, C_{dif} vs. potential, E , curves. These, in turn, are important for describing the occupation of the host lattice sites by inserted ions and (or) electrons in terms of intercalation isotherms. Short-range interactions between the inserted ions and lattice distortions affect greatly the shape of intercalation isotherms.

Dynamic characteristics of \rightarrow *phase transitions* upon intercalation after application of an infinitely small potential step may include a slow process of \rightarrow *nucleation* and the growth of primary droplets of a new phase (more concentrated with the inserted ions) at the boundary with the solution electrolyte. After that, a continuous boundary of the new phase is formed, which moves into the host's interior in a diffusion-like manner. This process can be formally described in terms of a moving

boundary or an ordinary, finite-space Cottrell \rightarrow *diffusion*. The latter approach allows for the evaluation of the effective chemical diffusion coefficients, D , which appear to be a sharp function of the electrode potential (minimum in D corresponds to maximum in C_{dif} or to the peak of SSCV). This is characteristic of a strong, short-range attraction between the intercalation sites, and can be clearly observed for Li intercalation into highly crystalline hosts such as graphite, transition metal oxides, and sulfides, etc. In contrast, Li ion insertion into disordered hosts such as hard carbons, or ion insertion into conducting polymers during their n- or p-doping, suffers from the lack of far-order. In addition, there is a wide distribution of particle sizes (or macromolecule length of conjugation). As a result, the related SSCV peaks are much broader than those of the crystalline hosts. Therefore, D vs. E plots manifest broad maxima in the vicinity of the SSCV peaks.

Insertion electrochemistry differs from the conventional electrochemistry of solution redox-species in the following respects:

1. Finite-space diffusion takes place during the charging of insertion electrodes at moderate frequencies, transforming into mainly capacitive behavior within the limit of very low frequencies, in contrast to the semi-infinite diffusion for solution redox-species (except for thin-layer solution electrochemistry); electrochemical impedance spectroscopy becomes a very useful diagnostic tool for the characterization of insertion mechanisms;
2. Within the limit of low frequencies, i.e., close to the equilibrium conditions of charging, the electrochemical behavior of insertion electrodes to a first approximation is similar to that of conventional metallic electrodes covered by specifically adsorbed redox-species. This resemblance is because the former electrodes can be characterized in terms of intercalation isotherms, whereas the latter are characterized in terms of \rightarrow *adsorption isotherms*. Generally, insertion processes can be conveniently considered as a three-dimensional analog of adsorption phenomena. As in the case of the adsorption process, ion intercalation may take place on sites having a different energy, thus giving rise to the ion-trapping effect in the host bulk;
3. At the same time, mechanisms of the solid-state diffusion of ions in the intercalation electrodes are numerous and more complicated than the mechanisms of surface diffusion. Crystallographic fea-

tures of the host accommodating the guest ions, the nature of transition sites for the elementary diffusion step, local interactions with surrounding “anions” and “cations” of the framework and with each other, and energetic and geometric non-uniformity of the intercalation electrodes all make diffusion motion a unique phenomenon typical of insertion electrochemistry.

Refs.: [i] McKinnon WR, Haering RR (1983) *Physical mechanisms of intercalation*. In: White RE, Bockris JO'M, Conway BE (eds) *Modern aspects electrochemistry*, vol. 15. Plenum, New York, pp 235–30; [ii] Bruce PG (1995) *Solid state electrochemistry*. Cambridge University Press, Cambridge, pp 1–344; [iii] Nazri GA, Pistoia G (eds) (2004) *Lithium batteries: science and technology*. Kluwer, Boston, p 344

ML, DA

Insertion electrodes — insertion electrodes the electrochemical activity of which relates to insertion processes. Insertion involves two types of materials: host materials and guest materials. Host materials provide a framework (lattice) of atoms/molecules, with specific sites such octahedral, tetrahedral, trigonal, or prismatic sites. The guest atoms or ions are inserted electrochemically (by applying an electrical field) and occupy these sites. Insertion can be in most cases reversible, thus leaving most host materials invariant in their physical and chemical properties after an insertion–deinsertion cycle.

The electrochemical insertion process includes \rightarrow *charge transfer* (red–ox reaction) by electrons and ions and \rightarrow *diffusion* of ions in the host to their sites. The inserted species can be cations (upon cathodic polarization), anions (upon anodic polarization), atoms, and molecules. Insertion of ions can be accompanied by co-insertion of solvent molecules from the \rightarrow *solvation shell* of the ions, which are dragged to the host together with the ions as the electrical field is applied. Insertion electrodes are highly important for the field of \rightarrow *Li batteries*, as most of the electrodes used in Li/Li-ion batteries are in fact insertion electrodes. Thereby, this entry concentrates mainly on Li ion insertion electrodes.

Lithium insertion: negative electrodes —

(i) Some transition-metal oxides or chalcogenides insert Li ion reversibly at low redox potentials, for example, TiO_2 , Li_xTiO_y , MoS_2 , MoO_2 . (ii) Lithium alloys – in this case lithium ions, react with other elements polarized to low potentials to **reversibly** form Li alloys. The reaction usually proceeds reversibly according to the general scheme $\text{Li}_x\text{M} \xrightleftharpoons[\text{charge}]{\text{discharge}} x\text{Li}^+ + x\text{e}^- + \text{M}$. Among the relevant elements: Al, Si, Sn, Pb, In, Bi, Sb, Ag, and

also mixtures/alloys of these elements (thus forming ternary and quaternary Li alloys that behave as insertion electrodes). Generally, these elements undergo major structural changes while alloying with lithium. In most cases even the binary systems $\text{Li}^- \text{M}$ are very complex. Sequences of stoichiometric intermetallic compounds and different $\text{Li}_x \text{M}$ phases are usually formed during lithiation of the above elements, characterized by several steps. (iii) Polymers such as substituted polythiophene were suggested as negative electrodes for batteries but they have moderate specific charges and a rather poor stability. (iv) Carbons—carbons are mostly used as the negative electrodes in rechargeable lithium batteries because they exhibit high specific capacity, low enough redox potentials, and stability upon cycling due to their dimensional stability (they show better cycling performance than Li alloys). The insertion of lithium into carbons proceeds according to the general formula:

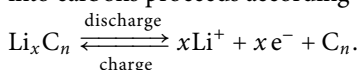

Upon electrochemical reduction (charging) of the carbon host, lithium ions from the electrolyte solution penetrate into the carbon and form lithium/carbon intercalation compounds; the reaction is reversible. The quality for sites capable of lithium accommodation strongly depends on the crystallinity, the microstructure, and the micromorphology of the carbonaceous material. → *carbons* that are capable of reversible lithium intercalation can roughly be classified as ordered and disordered materials. The former ones have graphitic, layered structure. The latter ones may be soft (graphitizable, by heating) or hard (non graphitizable). A general feature of Li insertion into graphitic materials is the stepwise processes which form Li-graphite stages in which layers of Li atoms are intercalated between graphene planes. The stability of all negative Li-insertion electrodes depends on passivation phenomena because when the red–ox activity of Li-insertion compounds is below 1.5 V vs. Li/Li^+ , they undergo spontaneous reactions in most relevant polar aprotic solvents. Such reactions can be inhibited only by formation of protecting films, which result as products of solution reduction by the lithiated materials.

Li-insertion materials for positive electrodes —

These include mostly transition metal oxides and sulfides that can be classified in several ways, e.g., according to their red–ox potentials 2, 3, 4, 5 V vs. Li/Li^+ , or according to their structure, e.g., layered, spinel, inverse spinel, olivine. Typical 2–3 V materials are $\text{Li}_x \text{Mo}_6 \text{O}_8$ chevrel phase ($0 < x < 4$), TiS_2 , MoS_2 . Typical 3–4 V materials are $\text{Li}_x \text{MnO}_2$ ($0 < x < 1$), $\text{Li}_x \text{VO}_y$, $\text{Li}_x \text{CoO}_2$,

$\text{Li}_x \text{NiO}_2$, and $\text{LiMn}_2 \text{O}_4$ spinel. Typical 5 V materials are $\text{Li}_x \text{Mn}_{2-y} \text{M}_y \text{O}_4$ spinel with $\text{M} = \text{Ni}, \text{Cr}, \text{Cu}$. The basic reaction is: $\text{LiMO}_2 \xrightleftharpoons[\text{charge}]{\text{discharge}} x \text{Li}^+ + x \text{e}^- + \text{Li}_{1-x} \text{MO}_2$.

There are extensive studies on lithiation processes of various types of $\text{Li}_x \text{M}_{(1)y} \text{M}_{(2)z} \text{M}_{(3)k} \text{O}_2$ materials ($0 < x, y, z, k < 1$, $\text{M}_{(1)}, \text{M}_{(2)}, \text{M}_{(3)}$ different transition metals) in attempts to develop high-capacity, high-rate electrodes for Li-ion batteries.

Other types of insertion electrodes of interest

— Graphitic carbons can also insert anions at high potentials (e.g., PF_6^- ion potentials of >4 V vs. Li/Li^+ , from polar aprotic LiPF_6 solutions). There are reports on Mg-insertion electrodes. For instance, $\text{Mo}_6 \text{X}_8$ chevrel phases ($\text{X} = \text{S}, \text{Se}$) intercalate reversibly with magnesium ions (2 ions per formula). Mg ions can be inserted to VO_x compounds and to cubic TiS_2 .

Analyses of insertion electrodes include structural analysis by XRD, neutron diffraction, HRTEM with electron diffraction, chemical analysis by EDAX, XPS and dissolution followed by ICP, morphological analysis by electron microscopy, surface area measurements by gas adsorption, and electrochemical analysis by voltammetry chronopotentiometry (primary techniques) and fine electrochemical tools such as EIS, PITT, GITT, and SSCV.

Refs.: [i] Whittingham MS (2000) *Solid State Ionics* 134:169; [ii] Markevich E, Levi MD, Aurbach D (2005) *J Electroanal Chem* 580:231; [iii] Spahr ME, Buqa H, Würsig A, Goers D, Hardwick L, Novák P, Krumeich F, Dentzer J, Vix-Guterl C (2006) *J Power Sources* 153:300; [iv] Aurbach D, Markovsky B, Weissmann I, Levi E, Ein-Eli Y (1999) *Electrochim Acta* 45:67; [v] Jurewicz K, Frackowiak E, Béguin F (2004) *Appl Phys A* 78:981; [vi] Nakayama M, Ikuta H, Uchimoto Y, Wakihara M (2003) *J Phys Chem B* 107:10715; [vii] Aurbach D, Weissman I, Gofer Y, Levi E (2003) *The Chemical Record* 3:61; [viii] Winter M, Besenhard JO, Spahr ME, Novák P (1998) *Adv Mater* 10:725; [ix] Bruce HP, Kuhn A (1993) *J Power Sources* 41:253; [x] Peled E, Golodnitzky D, Ardel G (1997) *J Electrochem Soc* 144:L208; [xi] Novák P, Scheifele W, Joho F, Haas O (1995) *J Electrochem Soc* 142:2544; [xii] Sotani N, Shimada I, Suzuki T, Eda K, Kunitomo M (1998) *Solid State Ionics* 113–115:377; [xiii] Dunn B, Goodby JW, West AR, Bruce PG (eds) (1995) *Solid state electrochemistry (Chemistry of solid state materials)*. Cambridge University Press, Cambridge

DA, YT

Instability constant → *stability constant*

Instantaneous nucleation → *nucleation, subentry → instantaneous nucleation*

Insulator → *dielectric*

Insulators (electrical) — These are materials of high dielectric strength, resisting the flow of electrically charged particles. Though used in different contexts, the term ‘electrical insulator’ has generally the same meaning as the term ‘dielectric’. Electrical insulators are materials which lack movable electric charges and which therefore lack a low-resistance path for charge flow. When a difference in electrical potential is placed across a nonconductor, no free charges are exposed to the electric field, hence no flow of charges appears, and an electric current cannot arise. A measure of the degree to which a body opposes the passage of an electric current, is the electrical \rightarrow resistance (measured in Ohm, Ω), or its reciprocal quantity, the electrical \rightarrow conductance (measured in Siemens, S). The specific electrical resistance is for insulators given as 10^{10} , sometimes 10^{16} Ω m or higher, and these materials are often referred to as ‘low-dielectric-constant’, or ‘low- k ’ materials.

Electrically insulating materials are technically used to inhibit or prevent the conduction of electricity. The conductor, acting as a guide for the electric current, must be insulated at every point of contact with its support to prevent escape, or leakage, of the current. Insulators are commonly used as a flexible coating on electric wires and cables. In electronic devices, the active components are embedded within nonconductive epoxy or phenolic plastics, or within baked glass or ceramic coatings; printed circuit boards are made from epoxy plastic and fiberglass, supporting layers of copper foil conductors. Insulators used for high-voltage power transmission are either porcelain insulators or composite insulators. Alumina insulators are used where high mechanical strength is necessary. In recent times, there is a shift towards composite insulators which are less costly, of light weight, and they have excellent hydrophobic capability. They comprise a central rod made of fiber-reinforced plastic and outer weather sheds made of silicone rubber or EPDM (ethylene propylene diene monomer). Glass insulators are still used to mount electrical power lines, but since the late 1960s to a lesser extent compared with ceramic materials. In high-voltage systems containing transformers and capacitors, liquid nonconductor oil is the typical method used for preventing sparks. Among naturally-occurring substances, mica and asbestos have performed well as both thermal and electrical insulators. Other good insulators or dielectrics exemplarily include dry air, dry cotton, glass, paraffin, porcelain, resin, rubber, and varnishes.

Dielectric strength of various common electric insulator materials, in MV/m:

air: 3; bakelite: 24; neoprene rubber: 12; nylon: 14; paper: 16; polystyrene: 24; Pyrex glass: 14; quartz: 8; silicone oil: 15; strontium titanate: 8; Teflon: 60.

Refs.: [i] Gibilisco S (ed) (2001) *The illustrated dictionary of electronics*, 8th edn. McGraw-Hill, New York; [ii] Ho PS, Leu J, Lee WW (2002) *Low dielectric constant materials for IC applications*. Springer, Berlin; [iii] Berger LI (2003) *Dielectric strength of insulating materials*. In: Lide DR (ed) *CRC handbook of chemistry and physics*, 84th edn. 2003–2004. CRC press, pp 15–30 – 15–35; [iv] Ushakov VY (2004) *Insulation of high-voltage equipment (power systems)*. Springer, Berlin; [v] Milholland M (1983) *Milholland’s final and complete glass insulator reference book: Most about glass insulators*, 4th revision, 2nd printing update edn. Ben Print

MHer

Integration of currents — The amount of material affected by electrochemical processes is obtained from the electric charge by applying \rightarrow Faraday’s Law. In general,

the charge Q is determined according to $Q = \int_{t=0}^t I dt$

from the current I by integration from $t = 0$ to t . This simplifies to $Q = I \cdot t$ in a galvanostatic experiment. Under potentiostatic control, if I is not constant, numeric integration is used. This can be done by digital or analogue methods. If n current values I with a constant sample interval Δt were digitized, the charge Q is given by $Q = \Delta t \cdot \sum_{i=1}^n I_i$. Many \rightarrow potentiostats convert the cell current I into a proportional potential $U_I = R_I \cdot I$. This can be integrated by analogue circuits. Figure 1(a) shows an integrator based on an \rightarrow operational amplifier (OPA).

If the experiment starts with a discharged capacitor C , the output voltage is given by $U_{out} = \frac{1}{RC} \int_{t=0}^t U_I dt$ and the

charge is given by $Q = \frac{1}{R_I \cdot RC} \int_{t=0}^t U_I dt = \frac{U_{out}}{R_I}$. The switch

is used to discharge the capacitor after the experiment; a small resistor R_d limits the discharge current. Such integrators tend to drift, U_{out} changes continuously with time even for $U_I = 0$ due to an internal input offset of the amplifier. Furthermore, losses due to leakage of the capacitor must be respected, especially for longer peri-

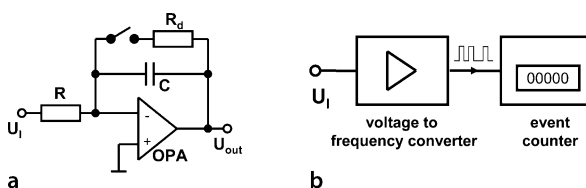

Integration of currents — Figure

ods of time. This is avoided by the semidigital method in Fig. 1(b). U_1 is transformed into a proportional pulse frequency f by a voltage-to-frequency converter according to $f = A \cdot U_1$. The pulses are counted in an event counter. The counter output, which means the total number of pulses N , is proportional to the charge Q :

$$Q = \int_{t=0}^t I dt = \frac{1}{R_1} \int_{t=0}^t U_1 dt = \frac{1}{R_1 \cdot A} \int_{t=0}^t f dt = \frac{N}{R_1 \cdot A}$$

Ref.: [i] Bard AJ, Faulkner LR (2001) *Electrochemical methods*, 2nd edn. Wiley, New York

MML

Integrators → operational amplifier

Intercalation electrodes → insertion electrodes

Interdigitated array — An interdigitated electrode configuration (see accompanying drawing) comprises two metallic electrodes, usually of micron dimensions, deposited on an insulating substrate. The potential of each electrode vs. a reference electrode can be individually controlled [i]. Applications are numerous and include time-of-flight measurements (see → *time-of-flight measurements*).

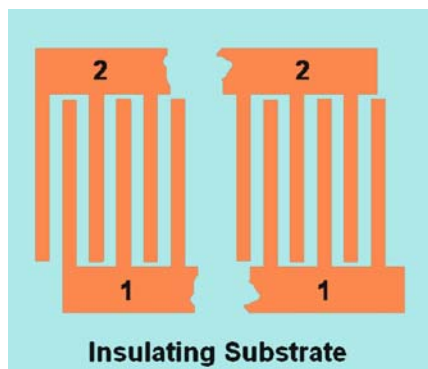

Interdigitated array — Figure

Ref.: [i] Chidsey CED, Feldman BH, Lundgren C, Murray RW (1986) *Anal Chem* 58:601

SWF

Interface — In chemistry and physics ‘interface’ means the two-dimensional plane separating two phases. The general thermodynamic requirement for the stability of an interface between two phases is a positive → *Gibbs energy* of formation, because otherwise the interface

would either fluctuate or disappear. Since the molecular forces on either side of an interface possess a specific anisotropy the structure of the utmost surface layers differs from that inside the phases (see → *double layer*). For these interfacial regions the term → *interphase* is also used.

See also → *electrode surface area*, → *Gibbs–Lippmann equation*, → *interfacial tension*, → *interface between two liquid solvents*, → *interface between two immiscible electrolyte solutions* → *Lippmann capillary electrometer*, → *Lippmann equation*; → *surface*, → *surface analytical methods*, → *surface stress*.

Refs.: [i] Adamson AW, Gast AP (1997) *Physical chemistry of surfaces*, 6th edn. Wiley, New York; [ii] Schmickler W (1996) *Interfacial electrochemistry*. Oxford University Press, New York; [iii] Bard AJ, Faulkner LR (2001) *Electrochemical methods*, 2nd edn. Wiley, New York; [iv] Wieckowski A (ed) (1999) *Interfacial electrochemistry. Theory, experiment, and applications*. Marcel Dekker, New York

FS

Interface between two liquid solvents — Two liquid solvents can be miscible (e.g., water and ethanol) partially miscible (e.g., water and propylene carbonate), or immiscible (e.g., water and nitrobenzene). Mutual miscibility of the two solvents is connected with the energy of interaction between the solvent molecules, which also determines the width of the phase boundary where the composition varies (Figure) [i]. Molecular dynamic simulation [ii], neutron reflection [iii], vibrational sum frequency spectroscopy [iv], and synchrotron X-ray reflectivity [v] studies have demonstrated that the width of the boundary between two immiscible solvents comprises a contribution from thermally excited capillary waves and intrinsic interfacial structure. Computer calculations and experimental data support the view that the interface between two solvents of very low miscibility is molecularly sharp but with rough protrusions of one solvent into the other (capillary waves), while increasing solvent miscibility leads to the formation of a mixed solvent layer (Figure). In the presence of an electrolyte in both solvent phases, an electrical potential difference can be established at the interface. In the case of two electrolytes with different but constant composition and dissolved in the same solvent, a → *liquid junction potential* is temporarily formed. Equilibrium partition of ions at the → *interface between two immiscible electrolyte solutions* gives rise to the ion transfer potential, or to the → *distribution potential*, which can be described by the equivalent two-phase Nernst relationship. See also → *ion transfer at liquid–liquid interfaces*.

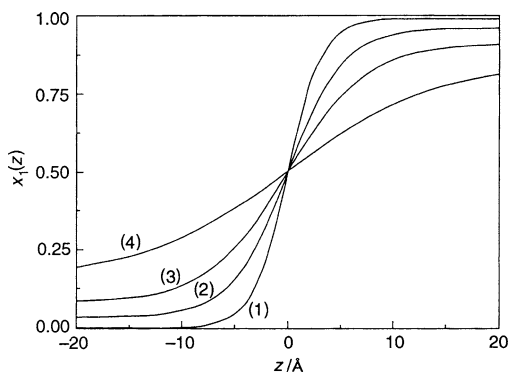

Interface between two liquid solvents — Figure. Composition profile at interface between liquid 1 and 2 as the mole fraction x_1 vs. the distance z from the interface for several values of energy of interaction of the two phases ϵ_{12}/kT : (1) 0.5, (2) 0.75, (3) 0.80, (4) 0.83. Reprinted with permission from [i]. © 1996 The Royal Society of Chemistry

Refs.: [i] Henderson DJ, Schmickler W (1996) *J Chem Soc Faraday Trans* 92:3839; [ii] Benjamin I (1997) *Annu Rev Phys Chem* 48:407; [iii] Strutwolf J, Barker AL, Gonsalves M, Caruana DJ, Unwin PR, Williams DE, Webster JRP (2000) *J Electroanal Chem* 483:163; [iv] Scatena LF, Brown MG, Richmond GL (2001) *Science* 292:908; [v] Luo GM, Malkova S, Pingali SV, Schultz DG, Lin BH, Meron M, Benjamin I, Vanysek P, Schlossman ML (2006) *J Phys Chem B* 110:4527

ZSam

Interface between two immiscible electrolyte solutions — An Interface between Two Immiscible Electrolyte Solutions (ITIES) is formed between two liquid solvents of a low mutual miscibility, each containing an electrolyte [i]. One of these solvents is usually water and the other is a polar organic solvent of moderate or high dielectric permittivity, e.g., 1,2-dichloroethane, 1,6-dichlorohexane, 2-octanone, nitrobenzene, *o*-nitrophenyl octyl ether, or benzonitrile, see also → *interface between two liquid solvents*. A high permittivity ensures at least partial dissociation of dissolved electrolyte(s) into ions and, thus, the electric conductivity of the liquid phase. An analogous system is the interface between an aqueous electrolyte solution and a room temperature molten salt [ii]. Two types of charge transfer processes can take place at ITIES: a) the transfer of an ion between the aqueous phase and the organic solvent phase, see also → *ion transfer at liquid–liquid interfaces*, and b) a single electron transfer between a redox system in one phase and a redox system in the other phase, see also → *electron transfer at liquid–liquid interfaces*. Both heterogeneous charge transfer reactions can be coupled to a series of homogeneous chemical reactions in one or the other phase, and to the partition of

neutral species. Often, ion association or complex formation occurs, which facilitates the ion transfer across ITIES; see also → *facilitated transfer (for ITIES)*. In addition, the partition of both solvents reflecting their mutual miscibility has to be considered.

ITIES can be classified as being nonpolarizable or polarizable depending on whether the interfacial potential difference can be controlled by applying a voltage from the external source [iii]. A nonpolarizable ITIES would be

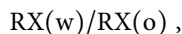

where RX represents a binary electrolyte, e.g., tetra-*n*-butylammonium chloride, in a partition equilibrium between the aqueous (w) and the organic solvent (o) phase. Other reversible ion partition systems including $RX(w)/RY(o)$ and $RX(w)/QX(o)$ can be classified as being practically nonpolarizable (nonpolarized), because a slight deviation of the → *Galvani potential difference*, $\Delta_o^w \phi = \phi^w - \phi^o$, would induce large currents passing through the interface [iii]. The state of an ideally polarizable ITIES is controlled entirely by the externally supplied charge, which means that ion transfer reactions are completely blocked and there are no common ionic species in the two phases [i]. Since the equilibrium concentrations of all ions in a real two-phase liquid system are always finite [iv], the charge supplied splits into the faradaic and nonfaradaic (charging) component. A polarizable ITIES can be realized using two different binary electrolytes RX and SY,

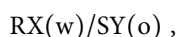

whose partition equilibria are shifted in favor of the phases w or o, respectively, e.g., LiCl and tetrabutylammonium tetraphenylborate [i], see also → *distribution (Nernst) potential*. In general, the external polarization of ITIES can be accomplished by means of the four-electrode methodology with two couples of the current-supplying (counter) and potential-measuring (reference) electrodes [v]. Uncompensated solution resistance effects due to high resistance of the organic solvent phase usually complicate polarization measurements. For this reason, ohmic potential drop compensation has to be introduced in a potential step or potential sweep experiment [vi]. Figure 1 shows cyclic voltammograms obtained with a planar ITIES using the electrochemical cell

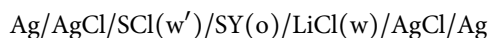

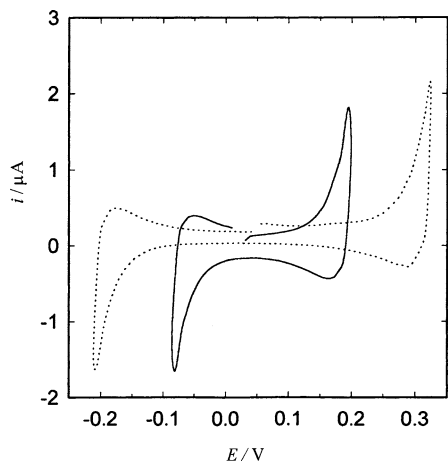

Interface between two immiscible electrolyte solutions — **Figure.** Cyclic voltammograms of 0.1 M LiCl in water and 0.01 M tetrabutylammonium tetrphenylborate (—) or tetrapentylammonium tetrakis[3,5-bis(trifluoromethyl)-phenyl]borate (···) in *o*-NPOE at a sweep rate of 20 mV s⁻¹, interfacial area 0.14 cm². Reprinted with permission from [vii]. © 1998 Elsevier B.V.

with *o* = *o*-nitrophenyl octyl ether and SY = tetrabutylammonium tetrphenylborate or tetrapentylammonium tetrakis[3,5-bis(trifluoromethyl) phenyl] borate. Depending on the ion concentrations and the standard ion transfer potentials $\Delta_0^w \varphi_i^{\ominus}$ (or the standard Gibbs energy of ion transfer $\Delta G_{tr,i}^{\ominus,w \rightarrow o}$), the onset of the electrical current at positive potential differences can be associated with the transfer of Li⁺ from *w* to *o*, and/or of the transfer of Y⁻ from *o* to *w* [vii]. Analogously, the onset of the electrical current at negative potential differences can be associated with the transfer of S⁺ from *o* to *w*, and/or of the transfer of Cl⁻ from *w* to *o*. The two current onsets determine the range of the potential differences (so-called potential window), within which the current is associated mainly with the charging of the electric double-layer ITIES, see also the → *Verwey-Niessen model*. Various aspects of ITIES have been discussed with a focus on history and electrochemical phenomena [viii], general electrochemistry [ix], mechanism of → *charge transfer* [x], electric → *double layer* [xi], charge transfer kinetics [xii], theory and methods [xiii], and chemical, biological, and pharmaceutical applications [xiv]. Recently, basic theoretical and methodological concepts have been reviewed [xv], and new experimental approaches to kinetic measurements have been developed [xvi]. Polarization studies have been extended to ITIES systems comprising room-temperature ionic liquids [xvii, xviii].

Refs.: [i] Koryta J, Vanýsek P, Březina M (1977) *J Electroanal Chem* 211:75; [ii] Kakiuchi T, Tsujioka N, Kurita S, Iwami Y (2003) *Electrochem*

Commun 5:159; [iii] Kakiuchi T (1996) *Partition equilibrium and ionic components in two immiscible electrolyte solutions*. In: Volkov AG, Deamer DW (eds) *Liquid-liquid interfaces. Theory and methods*. CRC Press, Boca Raton, pp 1-17; [iv] Hung LQ (1980) *J Electroanal Chem* 115:159; [v] Gavach C, Mlodnicka T, Guastalla J (1968) *CR Acad Sci C* 266:1196; [vi] Samec Z, Mareček V, Weber J (1979) *J Electroanal Chem* 100:841; [vii] Samec Z, Trojáněk A, Langmaier J (1998) *J Electroanal Chem* 444:1; [viii] Koryta J, Vanýsek P (1981) *Electrochemical phenomena at the interface between two immiscible electrolyte solutions*. In: Gerischer H, Tobias CW (eds) *Advances in electrochemistry and electrochemical engineering*, vol. 12. Wiley Interscience, New York, pp 113-176; [ix] Girault HH, Schiffrin DJ (1989) *Electrochemistry of liquid-liquid interfaces*. In: Bard AJ (ed) *Electroanalytical chemistry*, vol. 15. Marcel Dekker, New York, pp 1-141; [x] Girault HH (1993) *Charge transfer across liquid/liquid interfaces*. In: White RE, Conway BE, Bockris JOM (eds) *Modern aspects of electrochemistry*, vol. 25. Plenum Press, New York, pp 1-62; [xi] Samec Z (1988) *Chem Rev* 88:617; [xii] Samec Z, Kakiuchi T (1995) *Charge transfer kinetics at water-organic solvent phase boundaries*. In: Gerischer H, Tobias CW (eds) *Advances in electrochemical science and engineering*, vol. 4. VCH, Weinheim, pp 297-361; [xiii] Volkov AG, Deamer DW (eds) (1996) *Liquid-liquid interfaces. Theory and methods*. CRC Press, Boca Raton; [xiv] Volkov AG (ed) (2001) *Liquid interfaces in chemical, biological, and pharmaceutical applications*. Marcel Dekker, New York; [xv] Samec Z (2004) *Pure Appl Chem* 76:2147; [xvi] Cai CX, Mirkin MV (2006) *J Am Chem Soc* 128:171; [xvii] Quin BM, Ding ZF, Moulton R, Bard AJ (2002) *Langmuir* 18:1734; [xviii] Nishi N, Imakura S, Kakiuchi T (2006) *Anal Chem* 78:2726

ZSam

Interfacial area → *electrode surface area*

Interfacial tension — **Interfacial** tension between phases α and β ($\gamma^{\alpha\beta}$), or **surface** tension of phase α (γ^α) (when this phase is adjacent to vacuum) denotes the work (→ *Gibbs energy*, G) needed to change the surface area (A_s) at constant temperature (T) and pressure (p):

$$\gamma = (\partial G / \partial A)_{T,p} \quad (1)$$

Its unit is J m⁻² or N m⁻¹ [i-iii].

The work required to form a unit area of new surface is also called the surface free energy, the superficial work, the surface energy beside the surface tension [iv].

The **surface strain**, $d\varepsilon$, i.e., the change in surface area per unit area, can be **plastic** and/or **elastic**.

If one distorts the surface of a liquid, there is no barrier to prevent molecules from entering or leaving the surface. A new state of equilibrium can be reached, in which each surface molecule covers the same area as in the original undistorted state. The number of molecules in the surface region has changed, but the area per surface molecule has not. In this case the strain is said to be

plastic. The distortion of the surface of a **solid** far from its melting point, causes no change in the number of the molecules (atoms) in the surface region but the area occupied by each molecule differs from that in the undistorted case. Such a surface strain is called elastic. The work required per unit area to produce new surface under plastic strain conditions is independent of the new area formed. Under elastic strain conditions, the work required is a function of the area formed, because the greater the area formed, the greater the deviation from equilibrium intermolecular lattice spacing at the surface:

$$g = \gamma + A \left(\frac{\partial \gamma}{\partial A} \right)_{T, \mu_i, E} \quad (2)$$

where g is called the \rightarrow *surface stress*.

The surface tension depends on the potential (the excess charge on the surface) and the composition (chemical potentials of the species) of the contacting phases. For the relation between γ and the potential see \rightarrow *Lippmann equation*. For the composition dependence see \rightarrow *Gibbs adsorption equation*. Since in these equations γ is considered being independent of A , they can be used only for fluids, e.g., liquid|liquid such as liquid mercury|electrolyte, interfaces. By measuring the surface tension of a mercury drop in contact with an electrolyte solution as a function of potential important quantities, such as \rightarrow *surface charge density*, surface excess of ions, \rightarrow *differential capacitance* (subentry of \rightarrow *double-layer capacity*) of the electrode, can be derived from the \rightarrow *electrocapillary curve* (see also \rightarrow *Lippmann capillary electrometer*). The surface tension plays an important role in the behavior of \rightarrow *mercury electrodes* and \rightarrow *polarography*, as well as for the shape of the ‘immobilized’ droplets (see \rightarrow *Young equation*).

The temperature dependence of the surface tension of pure liquid is given by the Eötvös–Ramsay equation:

$$\gamma V^{2/3} = k_E (T_{cr} - T_x - T) , \quad (3)$$

where V is the molar volume, k_E is the Eötvös constant, T_{cr} is the critical temperature, $T_x = 4-6$ K, T is the temperature.

The effect of surface tension is to minimize the surface area, which may result in the formation of a curved surface, e.g., in the case of a droplet or a bubble or a cavity. The pressure on the concave side of an interface is always greater than the pressure on the convex side. This relation is expressed by the Laplace equation:

$$\Delta p = \frac{2\gamma}{r} , \quad (4)$$

where Δp is the pressure difference and r is the radius of curvature. (For flat surfaces $r \rightarrow \infty$, $\Delta p \rightarrow 0$.) When r is comparable with the thickness of the surface region, γ depends on the curvature [ii], which is of importance in systems of nanometer size.

A surface pressure (π) can be defined as the change of the interfacial tension caused by the addition of a given species to the base solution:

$$\pi = \gamma_{base} - \gamma , \quad (5)$$

where γ_{base} is the measured surface tension under the same conditions (e.g., at constant cell potential) which is frequently the surface tension measured in pure solvent or electrolyte solutions (see also \rightarrow *Langmuir–Blodgett films*).

The measurement of the work needed to increase the surface area of a solid material (e.g., an electrode metal) is more difficult. The work required to form unit area of new surface by stretching under equilibrium conditions is the surface stress (g_{ij}) which is a tensor because it is generally anisotropic. For an isotropic solid the work, the “generalized surface parameter”, or “specific surface energy” (γ^s) is the sum of two contributions:

$$\gamma^s = (\partial \varepsilon_p / \partial \varepsilon_{tot}) \gamma + (\partial \varepsilon_e / \partial \varepsilon_{tot}) g , \quad (6)$$

where ε_p an ε_e are the plastic and elastic contributions to the total strain ε_{tot} . In more general case both γ^s and g are tensors [iv–vi].

It follows that in all equations elaborated for liquid interfaces $d\gamma$ should be replaced by

$$d\gamma + (\gamma - g) d\varepsilon_e . \quad (7)$$

For instance, the Lippmann equation becomes:

$$\left(\frac{\partial \gamma}{\partial E} \right)_{T, p, \mu_i, \dots} = -\sigma - (\gamma - g) (\partial \varepsilon_e / \partial E)_{T, p, \mu_i} , \quad (8)$$

where σ is the free surface charge density.

The surface stress (specific surface energy) can be measured by \rightarrow *bending beam technique* or by electrochemical \rightarrow *Kösters laser interferometry* [vii]. (See also \rightarrow *surface stress measurements*.)

For measurement of interfacial tension see also \rightarrow *Wilhelmy plate (slide) method*, \rightarrow *drop weight method*, \rightarrow *ring method*. There are also a number of other static and dynamic methods for the determination the interfacial tension [viii].

Refs.: [i] Mills I, Cvitas T, Homann K, Kallay N, Kuchitsu K (eds) (1993) *IUPAC quantities, units and symbols in physical chemistry*. Blackwell Scientific Publications, Oxford, pp 63–64; [ii] Guggenheim EA (1993)

Thermodynamics. North Holland – Elsevier, Amsterdam, pp 46–58; [iii] Bard AJ, Faulkner LR (2001) *Electrochemical methods*, 2nd edn. Wiley, New York, pp 534–543; [iv] Linford RG (1978) *Chem Rev* 78:81–95; [v] Trasatti S, Parsons R (1986) *Pure Appl Chem* 58:437; [vi] Láng GG, Heusler KE (1994) *J Electroanal Chem* 377:1; [vii] Láng GG, Seo M, Heusler KE (2005) *J Solid State Electrochem* 9:347; [viii] Adamson AW, Gast AP (1997) *Physical chemistry of surfaces*, 6th edn. Wiley, New York, p 4–47

Intermetallic phase — A homogenous, usually well-ordered, solid phase that is constituted by at least two interacting metals. Intermetallic phases possess specific, characteristic physical and chemical properties. In contrast to frequently occurring solid solutions of metals in metals the intermetallic phases usually have their own original crystallographic structure which is different from the structures of the pure participating metals. The chemical reactivity, the → *passivation* capability and the gas evolution → *overpotentials* of intermetallic phases can significantly vary from those of the pure metals. With a few exemptions (e.g., intermetallic solid phases formed by silver with → *mercury*, Ag – Hg solid → *amalgams*) the stoichiometries of intermetallic phases are fixed, but sometimes a variation of several percent can be observed in the intermetallic phase diagrams.

Refs.: [i] Desch CH (2003) *Intermetallic compounds*. Wexford College Press, Palm Springs

GI

MD

Internal electric potential → *potential*

Internal electrolysis — Internal electrolysis, also known as spontaneous electrogravimetric analysis, is the deposition of a metal in an electrochemical cell for the purpose of gravimetric analysis without an external source of electrical energy by proper selection of the anode material. For example Ag can be determined in the presence of Pb, Cu, and Bi by use of a Cu anode. (See also → *electrogravimetry*).

Refs.: [i] Lingane JJ (1958) *Electroanalytical chemistry*. Chap. 17, *Inter-science*, New York; [ii] Sand HJS (1930) *Analyst* 55:309

AJB

Internal electrolyte — Electrolyte solution filling the internal chamber of a → *reference electrode* or → *ion-selective electrode*, separated from an external solution by a → *separator*. In reference electrodes a constant composition and constant concentration of the internal electrolyte secure a constant potential of the → *electrode*. In-

ternal electrolyte is also frequently called “filling solution”.

MD

Internal energy — Symbol: U_E , SI unit: J

Internal energy is the energy of a system determined by the system's thermodynamic state only. In simplest cases, this quantity can be visualized as the difference between total energy of a given system, its kinetic energy related to macroscopic motion, and its potential energy due to the presence of external fields such as gravitational, electric, and/or magnetic. The internal energy depends on the pressure and temperature, and comprises the energies of each particle in the system, including the contributions due to particle interactions, motion, vibrations, electronic shells, nuclear energy, etc.

The absolute value of internal energy cannot be measured by thermodynamic methods. However, this has no significance for thermodynamic analysis of a system, dealing with the derivatives and the internal energy differences between various states of the system. For any cyclic process, the internal energy increment is equal to zero.

See also: → *thermodynamics*, → *potential*, → *chemical potential*, → *Gibbs energy*.

Ref.: [i] Levine IN (1995) *Physical chemistry*, 4th edn. McGraw-Hill, New York

VK

Internal reference electrode → *reference electrode*

International Society of Electrochemistry, The — The precursor of the International Society of Electrochemistry (ISE) was the International Committee of Electrochemical Thermodynamics and Kinetics (Comité International de Thermodynamique et Cinétique Electrochimiques – CITCEE) which was founded in 1949 by leading European and American electrochemists. The first meeting held in Brussels in 1949 was organized by → *Pourbaix* who became the first secretary general (he served also as a president between 1957 and 1962), and Pierre Van Rysselberghe, a professor of chemistry at the University of Oregon was elected as the first president of the Society.

In the beginning the scientific activity focused on thermodynamical equilibrium and corrosion but later electrochemical kinetics as well as industrial applications gained ground.

The divisional structure implemented in 1971 has changed several times during the last decades. At present, the following scientific divisions exist: Ana-

lytical Electrochemistry, Bioelectrochemistry, Electrochemical Energy Conversion and Storage, Electrochemical Materials Science, Electrochemical Process Engineering and Technology, Molecular Electrochemistry, and Physical Electrochemistry.

The ISE has organized annual meetings since 1949, regional meetings, and from 2004 also Spring meetings. The lectures have been published in the form of Proceedings, and also in the journal of the Society called *Electrochimica Acta* that was launched in 1959.

The ISE presently has more than 1200 members from 62 different countries and is an associated member of IUPAC.

The address of the ISE office: Avenue Vinet 19, CH – 1004 Lausanne, Switzerland.

Web: <http://www.ise-online.org>.

International Powder Diffraction File → *diffraction*

Interphase — A spatial region at the interface between two bulk phases in contact, which is different chemically and physically from both phases in contact (also called interfacial region). The plane that ideally marks the boundary between two phases is called the → *interface*. Particles of a condensed phase located near a newly created (free) surface are subject to unbalanced forces and possibly to a unique surface chemistry. Modifications occurring to bring the system to equilibrium or metastability generally extend somewhat into one of the phases, or into both.

The region between the two phases where the properties vary from those in the bulk is the interfacial region. It may also be regarded as a distinct, although not autonomous, phase, and be called the interphase.

Thus, the “interface” is a two-dimensional surface, while the “interphase” is a thin, but three-dimensional entity, which possesses volume (Fig.). The properties of the interphase usually vary in the direction perpendicular to the surface. There may be no clear boundary between the interfacial region and the bulk of the phases, so that the thickness of the interphase depends on the model chosen to describe this region. The interphase may be considered as consisting of the surface regions of the two phases in contact. The properties of each of these generally differ from those of the free surfaces of the phases.

Interphases containing free charged components, which are usually accumulated or depleted in the surface regions, are called electrified interphases. When charged components are present in the two phases, electroneu-

trality must be fulfilled, on a time average, in any infinitesimal volume in the bulk of the phases. In the interphase, electroneutrality is also fulfilled in any volume with constant cross-section parallel to the interface, extending into each bulk phase.

Charged components may or may not be able to cross the interface between the two phases. In this respect, interphases may be divided into limiting types, unpolarizable and polarizable, respectively. Ideally, unpolarizable interphases are those in which the exchange of common-charged components between the phases proceed unhindered. Ideally, polarizable interphases are those in which there are no common components between the phases, or their exchange is hampered. Real interphases may approach, more or less well, one of the above two idealized cases.

GI An example of an interphase is the well-known and explored electrical → *double layer*. Another example is the passivating layer between electrode and electrolyte solutions. Such a layer on Li electrodes, which arises from the reductive decompositions of a small amount of the electrolyte solutions, was named SEI (solid electrolyte interphase). SEI is a crucial factor in the performance of Li-ion batteries since its nature and behavior affect Li-ion battery cycle-life, life time, power capability, and safety. Li electrodes (and Li–C electrodes as well) develop a classical interphase between them and all the relevant polar aprotic electrolyte solutions. All

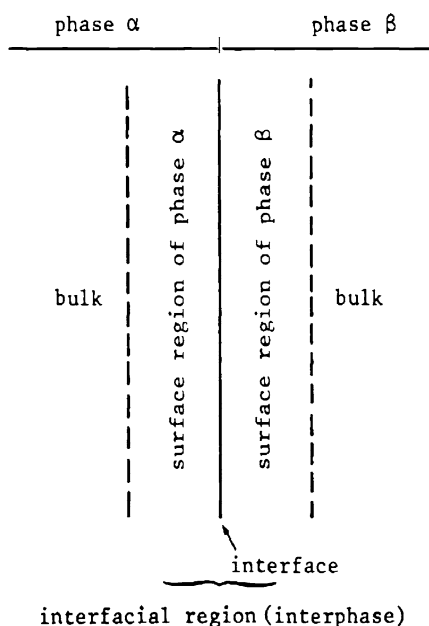

Interphase — Figure

polar solvents and many electrolyte anions (e.g., ClO_4^- , PF_6^-) are reduced by lithium or lithiated carbon to insoluble Li salts. These salts precipitate on the reactive electrodes' surface as surface films, and hence, passivate the electrodes. Thin films comprising Li salts can conduct Li ions under an electrical field. Hence, the surface films formed on Li or Li-C are nearly an ideal nonpolarizable interphase called SEI (solid electrolyte interphase) by Peled in 1979. Similar surface film formation occurs on magnesium electrodes in polar aprotic solutions. However, due to the bivalent nature of Mg^{2+} ions, surface films comprising Mg salt do not allow Mg^{2+} ion transport through them. Thereby, surface films formed on Mg electrodes are in fact an ideal polarizable interphase.

In a similar manner, most of active and moderately active metals are expected to develop an interphase when they are in contact with polar solvents (polar solvents always mean the existence of active bonds that can be reduced by metallic reagents).

Refs.: [i] Trasatti S, Parsons R (1986) *Pure Appl Chem* 58:437; [ii] Peled E (1979) *J Electrochem Soc* 126:2047; [iii] Lu Z, Schechter A, Moshkovich M, Aurbach D (1999) *J Electroanal Chem* 466:203

DA, EM

Iodine — Iodine, I_2 , is a halogen which occurs naturally mainly as iodide, I^- [i]. Iodine (Greek: “ioeides” for “colored violet”) is a black solid with a melting point of 113.6°C which is readily undergoing sublimation to form a violet gas. Iodine occurs in the oxidation states $-1, 0, +1, +3, +5, +7$ and it possesses a rich redox chemistry [ii]. In aqueous solution the formation of I_2 from I^- occurs with a standard potential of 0.621 V vs. SHE and this oxidation process is preceded by the formation of I_3^- with a standard potential of 0.536 V vs. SHE. For the reaction $\text{I}_2(\text{cryst}) + 2\text{e}^- \rightarrow 2\text{I}^- E^\ominus = 0.535\text{ V}$. The I^-/I_3^- redox couple is employed, for example, in solar cells [iii] and in long-lived lithium-iodine battery systems. The oxidation of I_2 in organic solvents results formally in “ I^+ ” intermediates which is a powerful oxidant and useful, for example, in electro-synthetic chemical processes [ii].

Refs.: [i] Holleman AF, Wiberg N (1995) *Inorganic chemistry*. Academic Press, London; [ii] Marken F (2006) *The electrochemistry of halogens*. In: Bard AJ, Stratmann M, Scholz F, Pickett CJ (eds) *Inorganic Chemistry. Encyclopedia of electrochemistry*, vol. 7a. Wiley-VCH, New York, p 291; [iii] Papageorgiou N, Maier WF, Grätzel M (1997) *J Electrochem Soc* 144:876

FM

Ion — Atom or group of atoms with a net electric charge. A negatively-charged ion, which has more electrons in

its electron shells than it has protons in its nuclei, is called an \rightarrow *anion*, while a positively-charged ion, which has fewer electrons than protons, is called a \rightarrow *cation*. Atomic and polyatomic ions are denoted by a superscript with the sign of the net electric charge and the number of deficient or excess electrons. For example, H^+ , Fe^{3+} , Cl^- , SO_4^{2-} . The term “ion” as well as “anion”, “cation”, “electrode”, “electrolyte”, etc. was introduced by \rightarrow *Faraday*, who believed that ions were produced in the process of electrolysis. Later in 1883, however, \rightarrow *Arrhenius* reached the modern concept that an electrolyte is dissociated into ions, even in the absence of an electric current. Ions thus produced in solution are solvated, i.e., associated with solvent (water) molecules to form solvated ions (\rightarrow *hydrated ions*).

TO

Ion association — A solution of a weak electrolyte such as acetic acid shows a molar \rightarrow *conductance* considerably lower than that expected for a strong electrolyte. This is due to the ion association, that is, ion-pair formation of the electrolyte ions M^+ and X^- :

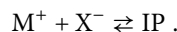

The ion pair IP has no net charge and therefore does not contribute to the solution conductance. The ion association constant is expressed as

$$K_A = \frac{a_{\text{IP}}}{a_{\text{M}^+} a_{\text{X}^-}},$$

where a_{IP} , a_{M^+} , and a_{X^-} are the activities of IP, M^+ , and X^- , respectively. \rightarrow *Bjerrum N* assumed that ion-pair formation will occur when the distance a between M^+ and X^- (i.e., the sum of their ionic radii) is within a certain limit q , and derived a theoretical equation for K_A :

$$K_A = \frac{4\pi N_A}{1000} \int_a^q r^2 \exp\left(\frac{2q}{r}\right) dr, \quad q = \frac{|z_+ z_-| e^2}{8\pi\epsilon_0 \epsilon k T},$$

where N_A is the Avogadro constant, ϵ_0 the permittivity of vacuum, ϵ the dielectric constant of the medium, e the elementary charge, k the \rightarrow *Boltzmann constant*, T the absolute temperature, and z_+ and z_- are the charge numbers of M^+ and X^- , respectively. The q value was arbitrarily set to the distance from a reference cation at which the probability of finding an anion is the minimum. On the other hand, R.M. Fuoss [iii] defined the ion pair as two oppositely charged ions that are in contact, i.e., at a distance $r = a$, and derived the following equation for K_A :

$$K_A = \frac{4\pi N_A a^3}{3000} \exp\left(\frac{2q}{a}\right).$$

These theories based on simple electrostatic models, however, do not always predict well the experimental data, because they have some problems regarding the effects of ion solvation on the value a and of the dielectric saturation on ϵ . See also \rightarrow *association constant*.

Refs.: [i] Barthel JMG, Krienke H, Kunz W (1998) *Physical chemistry of electrolyte solutions: modern aspects (Topics in physical chemistry, vol. 5)*. Springer, New York; [ii] Bockris JO'M, Reddy AKN (1998) *Modern electrochemistry, vol. 1, 2nd edn*. Wiley, New York; [iii] Fuoss RM (1958) *J Am Chem Soc* 80:5059

TO

Ion channel \rightarrow *ion transport through membranes and ion channels*

Ion-dipole interaction — One of the intermolecular interactions, which acts between an ion and \rightarrow *dipoles* such as water molecules. The ion-dipole interaction shows a significant stabilizing effect on the \rightarrow *hydration* or \rightarrow *solvation* of ions (see \rightarrow *hydrated ion*). The interaction energy U_{I-D} between a dipole and an ion placed at a distance r from the dipole center is approximately given by

$$U_{I-D} = -\frac{z_i e \mu \cos \theta}{4\pi \epsilon_0 r^2},$$

where z_i is the charge number of the ion, e the elementary charge, μ the \rightarrow *dipole moment*, ϵ_0 the permittivity of vacuum, and θ the angle at which the dipole is oriented to the line joining the centers of the ion and dipole. The above approximate equation is valid if the distance between the charges in the dipole is negligible compared with r . When the ion and dipole exist in a medium with the relative permittivity ϵ_r , U_{I-D} should be corrected for the medium effect, approximately by replacing ϵ_0 with $\epsilon_r \epsilon_0$ in the above equation.

Refs.: [i] Bockris JO'M, Reddy AKN (1998) *Modern electrochemistry, vol. 1, 2nd edn*. Wiley, New York; [ii] Israelachvili JN (1985) *Intermolecular and surface forces*. Academic Press, London

TO

Ion exchange — Process in which ions are extracted from a solution to an ion exchanger, an insoluble solid, or gel. Typical ion exchangers are ion-exchange resins, \rightarrow *zeolites*, montmorillonite, and clay. Ion exchangers are either cation exchangers for positively charged cations or anion exchangers for negatively charged anions. Ion exchange for ions A and B using an ion exchanger R can be expressed as

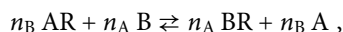

where n_A and n_B are the charge numbers (not including the signs) of ions A and B, respectively. This process

is reversible and the ion exchanger can be regenerated by washing with an excess of the ions to be exchanged. Equilibrium constants of the ion-exchange reactions of ions are called the selectivity coefficients, which are governed mainly by the magnitude of hydrophobicity or dehydration energy of the ions. For example, the selectivity coefficients of monovalent anions are generally ordered according to the so-called \rightarrow *Hofmeister series*: $Cl^- < NO_2^- < Br^- < NO_3^- < I^- < SCN^- < ClO_4^-$.

Most ion-exchange resins are based on crosslinked polystyrene. There are four main types differing in their functional groups:

- strongly acidic (e.g., sulfonic acid groups);
- strongly basic (e.g., trimethylammonium groups);
- weakly acidic (e.g., carboxylic acid groups);
- weakly basic (e.g., amino groups).

Ion-exchange resins are widely used in water purification and softening, separation and detection of ions (including biomolecules such as proteins) by ion exchange chromatography, etc.

Ion exchange can proceed also as a surface-confined process, in which the substituted ions are bound on the surface of a solid (or liquid) phase. Ion-exchange resins, as well as the above-mentioned ion exchangers, are often immobilized on electrode surfaces and used for the accumulation of metal ions, etc. It is improper to term such a surface ion-exchange reaction as "ion transfer", because this term is generally referred to the movement of ions from a solution phase to another bulk phase (not onto the surface). See also \rightarrow *ion-exchange membrane*.

Refs.: [i] Helfferich FG (1995) *Ion exchange*. Dover Publications, Mineola

TO

Ion-exchange membrane — Thin sheet or film of ion-exchange material, which may be used to separate ions by allowing the preferential transport of either cations (for a cation-exchange membrane) or anions (for an anion-exchange membrane). If the membrane material is made from only ion-exchange material, it is called a homogeneous ion-exchange membrane. If the ion-exchange material is embedded in an inert binder, it is called a heterogeneous ion-exchange membrane. Higher ion-selective permeability (i.e., a higher \rightarrow *transport number*) and lower electric resistance are required for practical use of ion-exchange membranes. Typical ion-exchange materials are hydrocarbon-based polymers (e.g., crosslinked polystyrene) and perfluorocarbon-based polymers (e.g., \rightarrow *Nafion*), into which functional

groups such as sulfonic acid and trimethylammonium groups are incorporated. These ion-exchange membranes are widely used for production of ultrapure water, desalination of seawater, production of salt from seawater, construction of \rightarrow fuel cells, etc. See also \rightarrow ion-exchange, \rightarrow electrodialysis.

Refs.: [i] Helfferich FG (1995) *Ion exchange*. Dover Publications, Mineola TO

Ion-pair formation — See \rightarrow ion association

Ion partition — The partition coefficients of ions between two liquid phases can be determined with electrochemical methods: See \rightarrow ion transfer at liquid-liquid interfaces, and \rightarrow droplets, electrochemistry of immobilized~.

FS

Ionic potential — Function defined by $\phi \equiv z/r$, where z and r are the valence and radius of an ion, respectively. This function was introduced by G.H. Cartledge [i, ii], who used it as a quantitative basis of the periodic classification of elements. The ionic potential is directly connected with the heat of hydration of ions (see \rightarrow Born equation), and thus related to the heat of solution of salts, acidic properties of ions, and others. It is also known that the ionic potential is correlated with electrochemical redox potentials (e.g., for solid metal hexacyanometallates [iii]).

Refs.: [i] Cartledge GH (1928) *J Am Chem Soc* 50:2855; 50:2863; [ii] Cartledge GH (1930) *J Am Chem Soc* 52:3076; [iii] Barcena Soto M, Scholz F (2002) *J Electroanal Chem* 521:183

TO

Ion product — A temperature-dependent constant related to pure substances that can dissociate forming ions and remain in equilibrium with them. It is the product of the ion \rightarrow activities raised to the stoichiometric coefficients of such ionic species in former pure substance. Since the concentration of the pure substance is practically a constant, it is not included in this equilibrium expression. Common pure substances characterized by an ion-product constant are \rightarrow amphiprotic solvents, and those salts that are partially dissolved in a given solvent. In the latter case, the ion product is synonymous with \rightarrow solubility product. The following table (Table 1) summarizes self-ionization ionic products and \rightarrow autoprotolysis constants of some \rightarrow amphiprotic solvents [i].

Ref.: [i] Reichardt C (2004) *Solvents and solvent effects in organic chemistry*. Wiley-VCH, Weinheim

Ion pumps (physiological) \rightarrow ion transport through membranes and ion channels

Ion-selective electrodes — Used in \rightarrow potentiometry as \rightarrow indicator electrode that responds to the \rightarrow activity of a primary ion in presence of various other (interfering) ions in the sample solution. The \rightarrow potential of an ion-selective electrode (ISE), measured against a \rightarrow reference electrode, (see figure) is proportional to the logarithm of the activity of the primary ion according to the \rightarrow Nernst equation, as long as there is no influence from interfering ions. An ISE is said to have a Nernstian response (\rightarrow Nernst equilibrium) when the slope of the linear part of the calibration plot of the potential vs. the logarithm of the activity (a_i) of a given ion i with charge z_i is (approximately) equal to $2.303(RT/z_iF)$ (59.16/ z_i mV per unit of $\log a_i$ at 25 °C). The preference of an ISE for the primary ion relative to the interfering ions is given by the \rightarrow selectivity coefficients, as originally defined in the \rightarrow Nikolskij-Eisenman equation. However, practically useful selectivity coefficients may also be obtained by methods that are independent of the Nikolskij-Eisenman equation.

The essential part of an ISE is the ion-selective membrane that contains fixed or mobile sites that interact with ions in the solution. The membrane is commonly based on a plasticized polymer, glass, single crystal, or a sparingly soluble salt. The back-side of the membrane is in contact with a liquid- or solid-state ion-to-electron transducer that completes the ISE. New materials, such

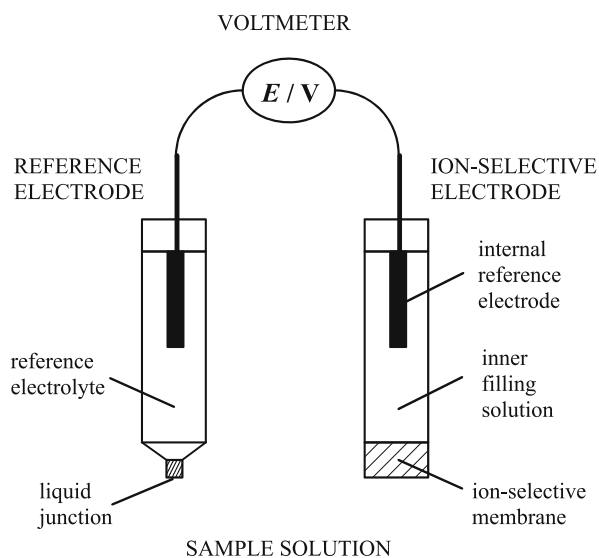

FG **Ion-selective electrodes** — Figure

Ion product — Table. Autoprotolysis constants ($K_{\text{auto}} = [\text{SH}_2^+] \cdot [\text{S}^-]$) of some amphiprotic solvents 'SH'. Values at 25 °C unless stated otherwise

Solvent	Conjugate cation	Conjugate anion	$\log(K_{\text{auto}}/\text{mol}^2 \text{L}^{-2})$
Sulfuric acid	H_3SO_4^+	HSO_4^-	3.33
2-Aminoethanol	$\text{HO} - (\text{CH}_2)_2 - \text{NH}_3^+$	$\text{HN}_2 - (\text{CH}_2)_2 - \text{O}^-$	5.7
Formic acid	$\text{HC}(\text{OH})_2^+$	HCO_2^-	6.2
N-Methylformamide	$\text{CH}_3 - \overset{+}{\text{N}}\text{H} = \text{CH} - \text{OH}$	$\text{CH}_3 - \text{N} = \text{CH} - \text{O}^-$	10.74
Hydrogen fluoride	H_2F^+	F^-	12.5 (0 °C)
Water	H_3O^+	HO^-	14.00
Acetic acid	$\text{CH}_3 - \text{C}(\text{OH})_2^+$	$\text{CH}_3 - \text{CO}_2^-$	14.45
Acetic anhydride	$\text{CH}_3 - \text{CO}^+$	$\text{CH}_3 - \text{CO}_2^-$	14.5 (20 °C)
Acetamide	$\text{CH}_3 - \text{CO} - \text{NH}_3^+$	$\text{CH}_3 - \text{CO} = \text{NH}$	14.6 (98 °C)
Deuterium oxide	D_3O^+	DO^-	14.96
1,2-Diaminoethane	$\text{H}_2\text{N} - (\text{CH}_2)_2 - \text{NH}_3^+$	$\text{H}_2\text{N} - (\text{CH}_2)_2 - \text{NH}^-$	15.2
1,2-Ethanediol	$\text{HO} - (\text{CH}_2)_2 - \text{OH}_2^+$	$\text{HO} - (\text{CH}_2)_2 - \text{O}^-$	15.84
Formamide	$\text{HCO} - \text{NH}_3^+$	$\text{HCO}^- = \text{NH}$	16.8 (20 °C)
Methanol	$\text{H}_3\text{C} - \text{OH}_2^+$	$\text{H}_3\text{C} - \text{O}^-$	17.2
Ethanol	$\text{H}_5\text{C}_2 - \text{OH}_2^+$	$\text{H}_5\text{C}_2 - \text{O}^-$	18.88
1-Propanol	$\text{H}_7\text{C}_3 - \text{OH}_2^+$	$\text{H}_7\text{C}_3 - \text{O}^-$	19.43
Hexamethylphosphoric triamide	$[(\text{H}_3\text{C})_2\text{N}]_3\overset{+}{\text{P}} - \text{OH}$		20.56
1-Pentanol	$\text{H}_{11}\text{C}_5 - \text{OH}_2^+$	$\text{H}_{11}\text{C}_5 - \text{O}^-$	20.65
2-Propanol	$(\text{H}_3\text{C})_2\text{C} - \text{OH}_2^+$	$(\text{H}_3\text{C})_2\text{C} - \text{O}^-$	20.80
1-Butanol	$\text{H}_9\text{C}_4 - \text{OH}_2^+$	$\text{H}_9\text{C}_4 - \text{O}^-$	21.56
Ethyl acetate	$\text{H}_3\text{C} - \text{COH} = \overset{+}{\text{O}} - \text{C}_2\text{H}_5$	$\text{H}_2\text{C} = \text{C} - \text{OC}_2\text{H}_5$ O^-	22.83
N,N-Dimethylacetamide	$\text{H}_3\text{C} - \text{COH} = \overset{+}{\text{N}} - (\text{CH}_3)_2$	$\text{H}_2\text{C} = \text{C} - \text{N}(\text{CH}_3)_2$ O^-	23.95
1-Methyl-2-pyrrolidinone			24.15
Tetrahydrothiophene-1,1-dioxide			25.45
2-Butanone	$\text{H}_3\text{C} - \text{CH}_2 - \underset{\text{HO}^+}{\underset{\parallel}{\text{C}}} - \text{CH}_3$	$\text{H}_3\text{C} - \text{CH} = \underset{\text{O}^-}{\underset{\parallel}{\text{C}}} - \text{CH}_3$	25.94
2-Methyl-2-propanol	$(\text{H}_3\text{C})_3\text{C} - \text{OH}_2^+$	$(\text{H}_3\text{C})_3\text{C} - \text{O}^-$	26.8
Ammonia	H_4N^+	H_2N^-	32.5 (-33 °C)
Acetone	$(\text{H}_3\text{C})_2\text{C} = \overset{+}{\text{O}}\text{H}$	$\text{H}_2\text{C} = \underset{\text{O}^-}{\underset{\parallel}{\text{C}}} - \text{CH}_3$	32.5
Dimethyl sulfoxide	$(\text{H}_3\text{C})_2\overset{+}{\text{S}} - \text{OH}$	$\text{H}_2\text{C} = \underset{\text{O}^-}{\underset{\parallel}{\text{S}}} - \text{CH}_3$	33.3
Acetonitrile	$\text{H}_3\text{C} - \text{C} \equiv \overset{+}{\text{N}}\text{H}$	$\text{H}_2\text{C} = \text{C} = \text{N}^-$	≥ 33.3

as \rightarrow *conducting polymers*, have emerged as promising ion-to-electron transducers in all-solid-state ISEs.

Belonging to the family of \rightarrow *electrochemical sensors*, ISEs are used as \rightarrow *potentiometric sensors* for the determination of various inorganic and organic ions. The

largest routine application of ISEs is the determination of electrolytes, such as Na^+ and K^+ , in clinical analysis. The well-known pH electrode (\rightarrow *pH-sensitive electrodes*, \rightarrow *glass electrodes*) is another typical example of an ISE. The range of activities covered by ISEs is commonly ca.

10^{-6} – 1 M, the pH glass electrode being an exception with a very broad linear range (pH 0–14). However, recently the \rightarrow *detection limit* of several ISEs has been dramatically improved towards picomolar (10^{-12} M) concentrations, which is promising concerning potentiometric trace-level analysis. For characteristics of ion-selective electrodes see also \rightarrow *response time*, \rightarrow *response volume*, and \rightarrow *selectivity coefficient*.

Ref.: [i] Morf WE (1981) *The principles of ion-selective electrodes and of membrane transport*. Elsevier, New York; [ii] Umezawa Y, Umezawa K, Sato H (1995) *Pure Appl Chem* 67:507; [iii] Bakker E, Bühlmann P, Pretsch E (1997) *Chem Rev* 97:308; [iv] Bobacka J, Ivaska A, Lewenstam A (2003) *Electroanalysis* 15:366; [v] Sokalski T, Ceresa A, Zwickl T, Pretsch E (1997) *J Am Chem Soc* 119:11347; [vi] Bakker E, Pretsch E (2005) *Trends Anal Chem* 24:199

Ion-sensitive field effect transistor (ISFET) — In a semiconductor device based on the principle of the field effect transistor (FET) the current between two \rightarrow *semiconductor* electrodes (designated source and drain) is controlled by a third electrode, the gate. In an ISFET this gate is modified on its surface in a way which makes the surface ion-responsive (-selective and -sensitive). Changes in the concentration of the species in the solution in contact with the gate surface thus control the current between source and drain. In order to establish proper working conditions a reference electrode (e.g., a \rightarrow *REFET*) is needed. See also \rightarrow *CHEMFET*.

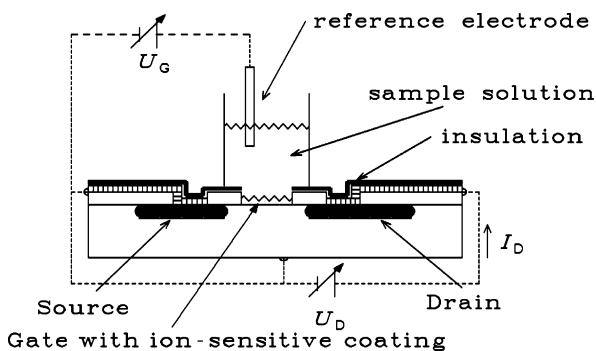

Ion-sensitive field effect transistor (ISFET) — Figure

Refs.: [i] Wang J (1994) *Analytical electrochemistry*. VCH, Weinheim; [ii] Janata J, Huber RJ (1979) *Ion Sel Electrode Rev* 1:31

RH

Ion transfer \rightarrow *charge-transfer reaction*, and \rightarrow *ion transfer at liquid–liquid interfaces*

Ion transfer at liquid–liquid interfaces — A single ion transfer between the aqueous phase (w) and the organic solvent phase (o) can be described by the reaction scheme

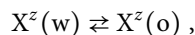

where X^z represents an ion with the charge number z . The equilibrium partition of this ion between the two adjacent phases is linked to the difference of inner (Galvani) electric potentials (ion-transfer potential), $\Delta_o^w \phi = \phi^w - \phi^o$, which can be described by the \rightarrow *Nernst equation*, see also \rightarrow *distribution (Nernst) potential*. A series of transient electrochemical and spectroelectrochemical techniques has been applied to study this charge-transfer reaction at the polarizable \rightarrow *interface between two immiscible electrolyte solutions* [i].

\rightarrow *Cyclic voltammetry* has been used mainly for the determination of the standard ion-transfer potential $\Delta_o^w \phi_X^\ominus$ (or the standard \rightarrow *Gibbs energy* of ion transfer $\Delta G_{tr,X}^{\ominus,w \rightarrow o}$), and the ion diffusion coefficient. The Figure shows an example of the cyclic voltammogram for the Cs^+ ion-transfer reaction at ITIES in the electrochemical cell

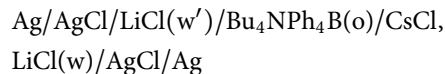

with LiCl and tetrabutylammonium tetraphenylborate ($\text{Bu}_4\text{NPh}_4\text{B}$) as supporting electrolytes in the aqueous and organic solvent phase, respectively. Measured

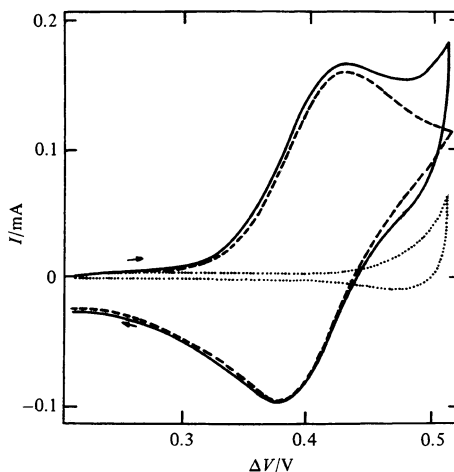

Ion transfer at liquid–liquid interfaces — Figure. Full line: Cyclic voltammogram (5 mV/s) of 1 mM Cs^+ in water. Aqueous phase: 50 mM LiCl; nitrobenzene phase: 50 mM $\text{Bu}_4\text{NPh}_4\text{B}$. Dotted line: supporting electrolyte, dashed line: voltammogram of Cs^+ corrected for the supporting electrolyte current. Reprinted with permission from [ii]. © 1979 Elsevier B.V.

voltammograms exhibit the same characteristics as those for the electron transfer at a metal electrode.

From a kinetic point of view, an ion transfer reaction can be expected to follow a first-order rate law [iii]

$$J = \frac{j}{zF} = k_f c^w(x=0) - k_b c^o(x=0),$$

where J is the ion flux in the direction $w \rightarrow o$, j is the electric current density, $c^w(x=0)$ and $c^o(x=0)$ are the ion concentrations on the aqueous and organic side of ITIES, respectively [iii]. Heterogeneous rate constants for the forward and backward ion transfer, k_f and k_b , respectively, are related to each other by virtue of the principle of microscopic reversibility, i.e., $k_f/k_b = \exp[zF(\Delta_o^w\phi - \Delta_o^w\phi_X^{\ominus})RT]$. Kinetics of an ion-transfer reaction is characterized by the apparent standard rate constant $k'_s = k_f(\Delta_o^w\phi_X^{\ominus}) = k_b(\Delta_o^w\phi_X^{\ominus})$ at the standard ion-transfer potential, and the apparent charge-transfer coefficient $\alpha = (RT/z_i F)(\partial \ln k_f / \partial \Delta_o^w\phi)$. ($\Delta_o^w\phi_i^{\ominus}$ or $\Delta_o^w\phi_i^{\ominus'}$ are the standard or formal ion-transfer potentials, respectively). Ion transfer kinetics has been studied mainly by using AC \rightarrow impedance techniques. Reported experimental values of k'_s fall in range 0.1–1 cm s⁻¹, and the values of α are usually about 0.5 [i]. Apparent activation energy for an ion transfer was found to be comparable with that for the ion transport (ca. 20 kJ mol⁻¹) [iv]. More recently, the application of steady-state voltammetry at nanometer-sized (10–300 nm) pipet electrodes has provided the values of k'_s exceeding 1 cm s⁻¹ [v].

The static \rightarrow double-layer effect has been accounted for by assuming an equilibrium ionic distribution up to the positions located close to the interface in phases w and o , respectively, presumably at the corresponding outer Helmholtz plane (\rightarrow Frumkin correction) [iii], see also \rightarrow Verwey–Niessen model. Significance of the Frumkin correction was discussed critically to show that it applies only at equilibrium, that is, in the absence of faradaic current [vi]. Instead, the dynamic Levich correction should be used if the system is not at equilibrium [vi, vii]. Theoretical description of the ion transfer has remained a matter of continuing discussion. It has not been clear whether ion transfer across ITIES is better described as an activated (Butler–Volmer) process [viii], as a mass transport (Nernst–Planck) phenomenon [ix, x], or as a combination of both [xi]. Evidence has been also provided that the Frumkin correction overestimates the effect of electric double layer [xii]. Molecular dynamics (MD) computer simulations highlighted the dynamic role of the water protrusions (fingers) and friction effects [xiii, xiv], which has been further studied theoretically [xv, xvi].

Irradiation of the ITIES by visible or UV light can give rise to a photocurrent, which is associated with the transfer of an ion in its excited state, or with the transfer of an ionic product of the photochemical reaction occurring in the solution bulk [xvii]. A model of the photoinduced ion transfer across the liquid–liquid interface was developed using MD calculations [xviii].

Refs.: [i] Samec Z (2004) *Pure Appl Chem* 76:2147; [ii] Samec Z, Mareček V, Weber J (1979) *J Electroanal Chem* 100:841; [iii] d'Epenoux, Seta P, Amblard G, Gavach C (1979) *J Electroanal Chem* 99:77; [iv] Wandlowski T, Mareček V, Samec Z, Fuoco R (1992) *J Electroanal Chem* 331:765; [v] Cai CX, Tong Y, Mirkin MV (2004) *J Phys Chem Soc* 108:1787; [vi] Mutomäki L, Kontturi K, Schiffrin DJ (1999) *J Electroanal Chem* 474:89; [vii] Senda M (1995) *Electrochim Acta* 40:2993; [viii] Samec Z (1979) *J Electroanal Chem* 99:197; [ix] Shao Y, Girault HH (1990) *J Electroanal Chem* 282:59; [x] Kakiuchi T (1992) *J Electroanal Chem* 322:55; [xi] Samec Z, Kharkats YI, Gurevich (1986) 204:257; [xiii] Kakiuchi T, Noguchi J, Senda M (1992) *J Electroanal Chem* 336:137; [xiii] Schweighofer K, Benjamin I (1996) *J Phys Chem* 99:9974; [xiv] Schweighofer K, Benjamin I (1999) *J Phys Chem* 103:10274; [xv] Marcus RA (2000) *J Chem Phys* 113:1618; [xvi] Frank S, Schmickler W (2006) *J Electroanal Chem* 590:138; [xvii] Samec Z, Brown AR, Yellowlees LJ, Girault HH, Base K (1989) *J Electroanal Chem* 259:309; [xviii] Benjamin I (2005) *Faraday Discuss* 129:47

ZSam

Ion transport through membranes and ion channels

\rightarrow membrane transport is vital to cell survival. The two major mechanisms used to transport \rightarrow ions and solutes across biological membranes are ion pumps and ion channels. Ion transport is essential to the generation of membrane potentials, signal transduction, and other biological processes. A membrane potential (\rightarrow Donnan potential) is a difference in electrical potential between intercellular and extracellular aqueous solutions. Ion channels are integral proteins that quickly facilitate the movement of specific ions across a biological membrane down their electrochemical gradient. Ion channels can facilitate the movement of approximately 10⁶–10⁸ ions per second. These channels are classified as mechanically gated, non-gated, voltage-gated, or ligand-gated. Non-gated channels remain permeable to specific ions. Voltage-gated channels become permeable when the membrane voltage is modulated above its threshold. Ligand-gated channels become permeable when the bound \rightarrow ligand is removed. Ion pumps employ a different mechanism. Ion pumps undergo conformational changes, and they require energy to move specific ions against the electrochemical gradient. Ion pumps can facilitate the movement of approximately 10–100 ions per second. Ion channels are highly specific filters, allow-

ing only desired ions through the cell membrane. Ion channels are devices in the engineering sense: They have signal inputs, power supplies, and signal outputs. They use their complex structure to convert input signals to output signals. Voltage-gated channels open or close depending on the transmembrane potential. Examples include the sodium and potassium voltage-gated channels of nerve and muscle cells that are involved in the propagation of action potentials, and voltage-gated calcium channels that control neurotransmitter release in presynaptic endings. Voltage-gated channels are found in neurons, muscle cells, and plant cells. Voltage-gated ion channels are membrane proteins that conduct ions at high rates regulated by the membrane potential. Voltage-gated channels consist of three major parts: the gate, the voltage sensor, and the ion-selective conducting channel. The voltage sensor is a region of a protein bearing charged amino acids that relocate upon changes in the membrane potential. The movement of the sensor initiates a conformational change in the gate of the conductive pathway thus controlling the flow of ions. The voltage-gated K^+ , Na^+ , and Ca^{2+} channels have a common domain of six helical transmembrane segments S1–S6. The fourth segment, S4, is the voltage sensor of the channel and has a symmetrical arrangement of charged residues, with each third residue being arginine or lysine. A voltage-sensing domain consists of membrane segments S1–S4 and controls the conformation of gates located in the pore domains S5–S6. *Ligand-gated* channels open in response to a specific ligand molecule on the external face of the membrane in which the channel resides. Examples include the “nicotinic” acetylcholine receptor, AMPA receptor, and other neurotransmitter-gated channels. Cyclic nucleotide-gated channels, calcium-activated channels, and others open in response to internal solutes and they mediate cellular responses to second messengers. Stretch-activated channels open or close in response to mechanical forces that arise from local stretching or compression of the membrane around them. Such channels are believed to underlie touch sensation and the transduction of acoustic vibrations into the sensation of sound. G-protein-gated channels open in response to G protein-activation via its receptor. Inward-rectifier K channels allow potassium to flow into the cell in an inwardly rectifying manner, for example, potassium flows into the cell but not out of the cell. They are involved in important physiological processes such as the pacemaker activity in the heart, insulin release, and potassium uptake in glial cells. Light-gated channels like channelrhodopsin 1 and channelrhodopsin 2 are directly

opened by the action of light. Resting channels remain open at all times.

Refs.: [i] Volkov AG, Brown CL (2006) *Nanodevices in nature*. In: Kumar CSSR (ed) *Nanodevices for life sciences*. Wiley-VCH, Weinheim, pp 440–463; [ii] Hille B (2001) *Ion channels of excitable membranes*. Sinauer Associates, Sunderland

AV

Ionic conductor → *conductor*

Ionic current — The propagation of charge by ions. Ionic currents can flow between electrodes in an → *electrolyte* solution, in → *solid electrolytes*, in molten salts (including → *ionic liquids*) and also in plasmas. In solid electrolytes ionic currents can be accompanied by electronic currents, whereas they will be always accompanied by electronic currents in plasmas.

FS

Ionic liquids — A class of preferably organic salts that are liquid at room temperature and may be simultaneously used as both solvents and supporting electrolytes for electrochemical reactions. Their unconventional properties include a negligible vapor pressure, a high thermal and electrochemical stability, and exceptional dissolution properties for both organic and inorganic systems.

Popular liquids for electrochemical applications are:

[BEIm] BF_4^- = 1-butyl-3-ethylimidazoliumtetrafluoroborate

[BMIm] PF_6^- = 1-butyl-3-methylimidazoliumhexafluorophosphate

[BMP] Tf_2N^- = 1-butyl-methyl pyrrolidinium bis(trifluoromethylsulfonyl) imide

Physical properties: conductivity: $\leq 10 \text{ mS cm}^{-1}$ at room temperature; viscosity: $\sim 10 \text{ mPa s} - 500 \text{ mPa s}$; diffusion coefficient of electroactive species: $10^{-7} \text{ cm}^2 \text{ s}^{-1}$.

See also → *room-temperature molten salts*.

Refs.: [i] Endres F, Zein El Abedin S (2006) *Phys Chem Chem Phys* 8:2101; [ii] Ohno Y (2005) *Electrochemical aspects of ionic liquids*. Wiley, New Jersey

JH

Ionic mobility — Quantity defined by the velocity of an ion moving in a unit electric field (SI unit: $\text{m}^2 \text{ V}^{-1} \text{ s}^{-1}$). The ionic mobility of ion i (u_i) is related to its molar ionic conductivity (λ_i) by $\lambda_i = |z_i| F u_i$, where z_i is the charge number of the ion. The ionic mobility is also related to the → *diffusion coefficient* (D_i) by the → *Nernst-Einstein*

equation: $u_i = (|z_i|F/RT)D_i$. In \rightarrow *electrophoresis*, the difference in u_i is utilized to separate biomolecular ions such as proteins and DNA or charged colloids by moving them in an electric field at different velocities. See also \rightarrow *molar ionic conductivity*.

TO

Ionic and mixed ionic–electronic conductors — Ionic conductors are solid systems that conduct electric current by movement of the ions. Mixed ionic–electronic conductors are those also conducting by the passage of electrons or holes (like metals or semiconductors). Usually only one type of ion (cation or anion) is predominantly mobile and determines conductivity.

As compared to metals, ionic conductors have lower \rightarrow *conductivity* (usually between 10^{-3} S/m and 10 S/m). Conductivity also grows as temperature increases (activation mechanism). Ionic conductivity in solids needs large populations of mobile ions and, therefore, a large number of empty sites (\rightarrow *defects in solids*) is required in the structure. Under such conditions, the movement of ions in solids is limited by their ability to propagate through the lattice. Thus, highly polarizable ions are preferred because they are likely to induce relatively small local distortion of the lattice, and their transfer requires low activation energy. The empty and occupied sites should also have similar potential energies. Ionic conductivity in solid frameworks is favored by the presence of open channels as well. Solid ionic conductors with conductivity at room temperature greater than 10^{-2} – 10^{-3} S m $^{-1}$ are often called “fast ion” or “superionic” conductors.

Ionic conductors can be classified according to the type of conducting ion as follows: cationic, where cations (e.g., Li $^+$, Na $^+$, K $^+$, Ag $^+$, Cu $^+$, Ti $^+$, Pb $^{2+}$, H $^+$) are predominant charge carriers; and anionic, where anions (e.g., F $^-$, O $^{2-}$) are predominant carriers.

Some examples of typical ionic conductors include: Ag $^+$ -ion conductors (AgI and RbAg $_4$ I $_5$ with the highest known conductivity at room temperature, ca. 30 S/m), Na $^+$ -ion conductors (sodium-beta-alumina, i.e., NaAl $_{11}$ O $_{17}$, Nasicon – Na $_3$ Zr $_2$ PSi $_2$ O $_{12}$), Li $^+$ -ion conductors (LiCoO $_2$, LiNiO $_2$, LiMnO $_2$), O $^{2-}$ -ion conductors (cubic stabilized ZrO $_2$, defected perovskites), F $^-$ -ion conductors (PbF $_2$, BaF $_2$, SrF $_2$, CaF $_2$). Examples of mixed conductors include Li-intercalated graphite or Li $_x$ CoO $_2$ of importance to Li-ion batteries.

There is also a large group of ion-conducting organic polymer electrolytes (typically containing solvent or low-molecular-weight plasticizer) that are capable of solvating dissolved alkali metal cations (e.g., Li $^+$).

As polymer matrices, various polyethers are frequently used because the mobile metal ions existing within are not only solvated but also coordinated by oxygen atoms originating from polyethers, e.g., poly(ethylene oxide)/PEO. The respective materials are often cross-linked, and they are bound together to form single three-dimensional networks.

Ionic conductivity also exists in redox conductors (see \rightarrow *solid-state electrochemistry*), when ion movement accompanies (is coupled to) the electron self-exchange reaction. In those systems, the redox centers are immobilized, but there exists a relatively large population of mobile ions (counter ions) to assure the local electroneutrality.

Ionic conductors have many practical applications. For example, solid ion conductors are used as solid electrolytes and electrode materials in \rightarrow *batteries*, \rightarrow *fuel cells*, \rightarrow *electrochromic devices* and \rightarrow *gas sensors*.

Refs.: [i] Surridge NA, Jernigan JC, Dalton EF, Buck RP, Watanabe M, Zhang H, Pinkerton M, Wooster TT, Longmire ML, Facci JS, Murray RW (1989) *Faraday Discuss Chem Soc* 88:1; [ii] Armand MB (1989) *Faraday Discuss Chem Soc* 88:65; [iii] Armand MB (1986) *Annu Rev Mater Sci* 16:245

PK

Ionic strength — Symbol: I , on molality basis: $I_m = 0.5 \sum m_i z_i^2$. SI unit: mol kg $^{-1}$; on molarity (concentration) basis: $I_c = 0.5 \sum c_i z_i^2$, SI unit: mol dm $^{-3}$ [i, ii].

It is a function expressing the effect of charge of the ions in a solution. It was introduced by \rightarrow *Lewis and Randall* [iii]. The factor 0.5 was applied for the sake of simplicity since for 1:1 electrolytes $I = c$ (electrolyte). It is an important quantity in all electrostatic theories and calculations (e.g., \rightarrow *Debye–Hückel theory*, \rightarrow *Debye–Hückel limiting law*, \rightarrow *Debye–Hückel–Onsager theory*) used for the estimation of \rightarrow *activity coefficients*, \rightarrow *dissociation constants*, \rightarrow *solubility products*, \rightarrow *conductivity of* \rightarrow *electrolytes* etc., when independently from the nature of ions only their charge is considered which depends on the total amount (concentration) of the ions and their charge number (z_i).

Refs.: [i] Mills I, Cvitas T, Homann K, Kallay N, Kuchitsu K (eds) (1993) *IUPAC quantities, units and symbols in physical chemistry*. Blackwell, Oxford, pp 50, 58; [ii] Guggenheim EA (1967) *Thermodynamics*. North-Holland, Amsterdam, p 282; [iii] Lewis GN, Randall M (1921) *J Amer Chem Soc* 43:1141

GI

Ionic strength buffer \rightarrow *buffer*

Ionics — This term has been suggested by Bockris for that branch of electrochemistry that concerns the struc-

ture and thermodynamics of phases containing ions, e.g., electrolyte solutions and kinetics of processes of charge transport within phases, mainly ion transport.

Ref.: [i] Bockris JO'M, Reddy AKN, Gamboa-Aldeco M (2000) *Modern electrochemistry, ionics*, vol. 1, 2nd edn. Kluwer/Plenum, New York

FS

Ionization — means formation of an ion or ions. Homogeneous ionization may occur by (a) loss of an electron from a neutral → *molecular entity*, (b) unimolecular heterolysis of such an entity into two or more ions, or (c) heterolytic substitution involving neutral molecules, such as

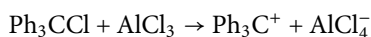
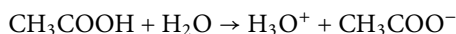

(electrophile assisted)

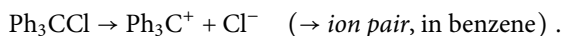

The loss of an electron from a singly, doubly, etc. charged cation is called second, third, etc. ionization. Heterogeneous ionization in condensed systems is due to → *charge transfer* between a neutral molecular entity persisting in one phase and electrode or across the → *interface between two immiscible electrolyte solutions*. See also → *dissociation*, → *ionization energy*.

Ref.: [i] Muller P (1994) *Pure Appl Chem* 66:1077

WK

Ionization energy, *I* — or ionization potential of an element is the energy required to remove an electron from its atom in the ground state, i.e., the state of the lowest energy, in a gas phase to form a positively charged ion. For the hydrogen atom, *I* is expressed by

$$I = -\frac{\mu_{\text{H}} e^4}{32\pi^2 \epsilon_0^2 \hbar^2}$$

(where μ_{H} is reduced mass for hydrogen, e is elementary charge, ϵ_0 is permittivity of free space, and $\hbar = h/2\pi$) and equals to 1312 kJ/mol or 13.598 eV/atom. Ionization energy periodically changes with atomic number. It generally increases across a row of the periodic table of elements being at minimum for the alkali metals, which have a single electron outside of a closed shell, and at maximum for the noble gases, which have closed shells. For example, Na requires only 496 kJ/mol or 5.14 eV/atom for ionization while Ne, the noble gas immediately preceding it in the periodic table, requires 2081 kJ/mol or 21.56 eV/atom.

Refs.: [i] Muller P (1994) *Pure Appl Chem* 66:1077; [ii] Atkins PW (1998) *Physical chemistry*, 6th edn. Oxford University Press, Oxford

WK

Ionophore — (Greek: ion = going, phorsis = being carried) General name introduced in 1967 by Pressman for various different, mostly organic molecules capable of selectively binding and releasing ionic species and moving them across phase boundaries by forming chelates or complexes (carrier ionophores). Because ionophores are mostly hydrophobic and lipophilic they are capable of transporting ions across hydrophobic surfaces or interfaces including membranes as being present in → *ion-selective electrodes*. Naturally occurring ionophors are macrolides and some peptide antibiotics. Synthetically prepared ionophores are crown ethers, cryptands, polyethers, and derivatives of ethylene diamine tetraacetic acid. Ion selectivity is based on the size of the inner free volume provided for ion inclusion and spatial arrangement and number of negative or positive charges possibly interacting with the ion. There are also species forming pores or transmembrane channels enabling ion transfer through membranes.

Refs.: [i] Amman D (1986) *Ion-selective microelectrodes*. Springer, Berlin;

[ii] Morf WE (1981) *The principles of ion-selective electrodes and membrane transport*. Elsevier

RH

IPCE — Incident photon to current efficiency (or incident photon to collected electron efficiency, or incident monochromatic photon to current conversion efficiency) determines the action spectrum for a device. In a photovoltaic device it measures the ratio between electrons driven by external circuitry and incident photons by a given device. The rate of collected electrons per unit area N_e is calculated by dividing the → *short-circuit current* density J_{sc} by the elementary charge e_0 , $N_e = \frac{J_{sc}}{e_0}$. The rate of incident photons N_{ph} is calculated by dividing the → *irradiance* at a wavelength λ , E_λ , by the corresponding photon energy, $\frac{hc}{\lambda}$, $N_{ph} = \frac{E_\lambda \lambda}{hc}$, where h is the → *Planck constant*. So, the IPCE is given by $IPCE = \frac{N_e}{N_{ph}} = \frac{1.24 \times 10^{-6} J_{sc}}{E_\lambda}$.

Refs.: [i] Glenis S, Horowitz G, Tourillon G, Garnier F (1984) *Thin Solid Films* 111:93; [ii] Brabec CJ, Sariciftci NS (2000) *Conjugated polymer-based plastic solar cells*. In: Hadziioannou G, van Hutten PF (eds) *Semiconducting polymers - chemistry, physics and engineering*. Wiley-VCH, Weinheim, pp 514–560

IH

IR_u (ohmic potential) drop — Drop in the potential of the → *working electrode* caused by the existence of the resistivity of the electrolyte when current (I) flows in the cell. Generally, it is the potential drop between the working electrode and the → *reference electrode*. In most experimental systems there is a substantial uncompen-

sated resistance, R_u , that produces the corresponding uncompensated ohmic potential drop, IR_u (see $\rightarrow IR$ drop compensation). As a result of this the true working electrode potential is lower than the expected potential by IR_u . The potential drop is biggest near the working electrode surface, since the current densities are the highest there. The value of R increases with decreasing size of the electrode, with the distance between the working and the reference electrodes, and with the specific resistivity of the electrolyte which depends on the concentration and the nature of the ions in the solution. Ref.: [i] Bard AJ, Faulkner LR (2001) *Electrochemical methods*, 2nd edn. Wiley, New York, section 15.6.3

IR drop compensation — The $\rightarrow IR$ drop (or ‘voltage drop’) of a conducting phase denotes the electrical potential difference between the two ends, for example of a metal wire, during a current flow, equaling the product of the current I and the electrical resistance R of the conductor. In electrochemistry, it mostly refers to the solution IR drop, or to the ohmic loss in an electrochemical cell. Even for a three-electrode cell (\rightarrow three electrode system), the IR drop in the electrolyte solution (between the \rightarrow working and the \rightarrow reference electrode) is included in the measured potential. To avoid or minimize this error, the electrolyte resistance between both electrodes has to be minimized, e.g., with the help of a \rightarrow Luggin probe (capillary) connecting the reference electrode compartment with a place near to the working electrode surface. The IR drop arises from the electrolyte volume between the working electrode surface and the tip of the Luggin probe because only through that volume an appreciable current passes, whereas the Luggin probe (or any other salt bridge) is practically current free. Synonymous terms for IR drop are ‘ohmic loss’, ‘ohmic overpotential’ or ‘ohmic polarization’, and ‘resistance overpotential’ or ‘ohmic polarization’.

For potential measurements without any current flow, the IR drop is zero. In all other cases, beside the electrode placement mentioned above, IR drop should be estimated and eliminated from the measured potential: It can be either compensated during potential control, or one can correct for it to obtain the real electrode potential. The IR drop can be straightaway determined by fast current interruption measurements: Shortly, e.g., 1 μ s, after a current shut-down, the potential is already decreased by all ohmic voltage drop while other overvoltages remain at their stationary values.

Optional electronic IR drop correction/compensation possibilities are integrated in most modern \rightarrow po-

tentiostats, though this technique is still far from perfection; at least a full IR drop compensation can still cause instability in the potential control, or, on the other hand, a partial compensation may result in an uncompensated IR drop portion. Some setups need a manual input of the solution resistance value.

An IR drop correction refers to a numerical correction of the measured potential of the working electrode for the solution IR drop, using the values of the current I and the resistance R of the electrolyte between the working and the reference electrodes; consequently, the absolute value of the corrected potential is smaller than the uncorrected.

ZS Ref.: [i] Roe DK (1996) *Overcoming solution resistance with stability and grace in potentiostatic circuits*. In: Kissinger PT, Heineman WR (eds) *Laboratory techniques in analytical chemistry*, 2nd edn. Marcel Dekker, New York, pp 195–235

MH

Irradiance — The irradiance E is the radiometric quantity that corresponds to the “incident power per unit area” at a given surface, given in W m^{-2} .

Ref.: [i] Meyer-Arendt JR (1995) *Introduction to classical and modern optics*. Prentice-Hall, Englewood Cliffs

IH

Iridium \rightarrow electrode materials

Iridium dioxide \rightarrow electrode materials

Irreversibility — This concept – as also the \rightarrow reversibility – is used in several ways. We speak of chemical irreversibility when the reaction can proceed only in one direction. Irreversibility in a thermodynamic sense is when a process generates \rightarrow entropy [i, ii].

The kinetics is called irreversible in electrochemistry when the charge-transfer step is very sluggish, i.e., the standard rate constant (k_s) and \rightarrow exchange current density (j_o) are very small. In this case the anodic and cathodic reactions are never simultaneously significant. In order to observe any current, the charge-transfer reaction has to be strongly activated either in cathodic or in anodic direction by application of \rightarrow overpotential. When the electrode process is neither very facile nor very sluggish we speak of quasireversible behavior.

In electrochemistry books it is often stated that the charge (electron) transfer is slow. This is not entirely correct because the act of the \rightarrow electron transfer itself is very fast, it occurs within 10^{-16} s, however, according to the advanced theories, e.g., \rightarrow Marcus theory, the reorganization of the structure of the reactants and products

and that of their \rightarrow solvation sphere or ligands need more time (10^{-11} s– 10^{-14} s).

The exchange current density depends also on the nature of the electrode. For instance, the rate of the \rightarrow hydrogen evolution reaction may change about 8 orders in magnitude, $j_0 \sim 10^{-4}$ A cm $^{-2}$ for Pt, while $j_0 \sim 10^{-12}$ A cm $^{-2}$ for Hg or Pb. It is the very reason that hydrogen evolution practically needs no overpotential at Pt but a rather high one, ca. -2 V at Hg. Because the electrode material acts as a catalyst, i.e., it specifically enhances the electrode reaction without being consumed, we speak of \rightarrow electrocatalysis. There might be several reasons why a metal or other electrodes increase the speed of the reaction. In this case the main event is the dissociative \rightarrow chemisorption of hydrogen molecules at Pt (it decreases the energy of activation) which does not occur at Hg.

The \rightarrow polarization curves for irreversible and quasireversible systems are shown in Figure (a). The respective \rightarrow Tafel plots are presented in Figure (b). Tafel plots can be constructed only for electrochemically irreversible systems, and kinetic parameters can be determined only when irreversible kinetics prevails. A switching from reversible to irreversible behavior and vice versa may occur. It depends on the relative values of k_s and the \rightarrow mass transport coefficient, k_m . If $k_m \gg k_s$ irreversible behavior can be observed. An illustration of the reversibility–irreversibility problem can be found in the entry \rightarrow reversibility.

Refs.: [i] Atkins PW (1995) *Physical chemistry*. Oxford University Press, Oxford, pp 123, 133; [ii] Guggenheim EA (1993) *Thermodynamics*. North-Holland, Amsterdam, p 362; [iii] Inzelt G (2002) *Kinetics of electrochemical reactions*. In: Scholz F (ed) *Electroanalytical methods*. Springer, Berlin, pp 29–47

GI

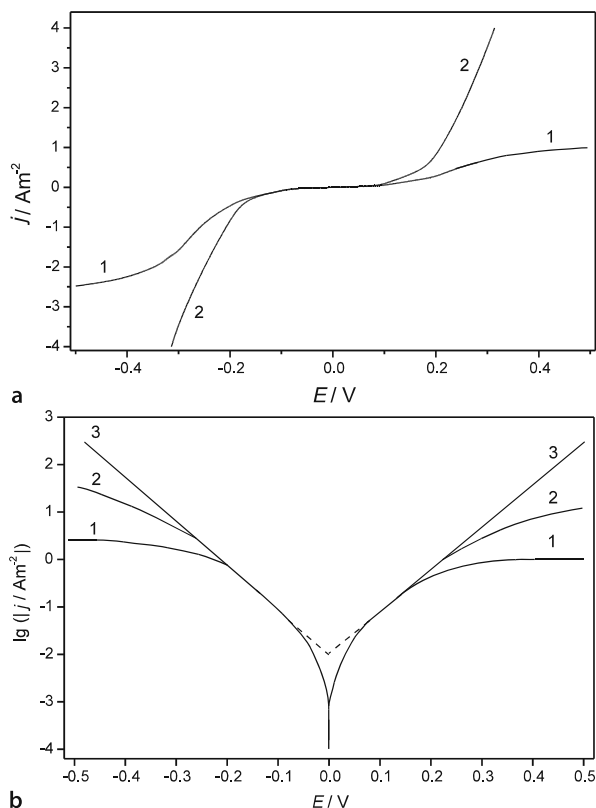

Irreversibility — Figure. Quasireversible and irreversible behavior. **a** Current-potential curves and **b** $\lg |j| - E$ plots (Tafel plots) for a redox system at different angular velocities of a rotating disc electrode: $\omega_r = 50$ s $^{-1}$ (1) and 10^4 s $^{-1}$ (2). Parameters are $E_e = 0.0$ V, $j_0 = 0.01$ A m $^{-2}$, $n = 1$, $D_R = 5 \times 10^{-10}$ m 2 s $^{-1}$, $D_O = 10^{-9}$ m 2 s $^{-1}$, $c_R^* = 10^{-3}$ mol dm $^{-3}$, $c_O^* = 2 \times 10^{-3}$ mol dm $^{-3}$, $v = 10^{-6}$ m 2 s $^{-1}$, $\alpha_a = \alpha_c = 0.5$, $T = 298.15$ K. For the sake of comparison the pure activation-controlled case (curves (3)) is also displayed

ISAB \rightarrow buffer, subentry \rightarrow ion strength buffer

ISFET \rightarrow ion-sensitive field effect transistor

Ising model — Developed by Ising as a basic model for magnetism. It consists of an ensemble of spins arranged on a spatial lattice. Each spin interacts with its nearest neighbors and with an external field through its z -component. Usually, the total spin is taken as $1/2$, so that the z -component can take up only two values; however, versions with higher spins also exist. The Ising model can be re-interpreted in various ways; in particular, values of the z -component can be taken to denote the presence or absence of particles; the resulting model is known as the \rightarrow lattice gas model, and under this name it has been applied in electrochemistry.

Ref.: [i] Ising E (1925) *Z Phys* 31:253

WS

Isoelectric focussing — A method for separating proteins based on their relative content of acidic and basic residues. This content/ratio is represented by a value known as the \rightarrow isoelectric point. Proteins are introduced into a gel (composed of polyacrylamide, starch, agarose, etc.) which already has a pH gradient or is capable of forming such a gradient after applying an electrical current. This pH gradient can be established by subjecting a mixture of \rightarrow polyampholytes (small polymer molecules with different isoelectric point values) to \rightarrow electrophoresis before the application of the sample protein. The pores of the gel are kept large to avoid the sieving effect. Sample proteins introduced into the gel

begin to move until they reach a place in the gel where the pH is equal to the isoelectric point of the protein. Isoelectric focusing can resolve proteins that differ in isoelectric point values by as little as 0.01.

Refs.: [i] Westermeier R (2001) *Electrophoresis in practice*. Wiley-VCH, Weinheim; [ii] Townshend A (ed) (1995) *Encyclopedia of analytical science*. Academic Press, New York, 1068

RH

Isoelectric point — The isoelectric point (pI) is the pH at which a molecule carries no net electrical charge. For an acid with only one amino and one carboxyl group (e.g., an amino acid) the pI can be calculated from the pK_a 's of this molecule:

$$pI = \frac{\sum pK_a}{2}$$

Proteins can be separated according to their isoelectric point in a process known as \rightarrow *isoelectric focussing*. See also \rightarrow *zwitter ion*.

RH

Isopotential point — In potentiometric measurements with the use of a \rightarrow *ion-selective electrode* (ISE) cell, the isopotential point is the potential difference between the internal and external reference electrodes which is independent of temperature. The isopotential point is governed by a particular activity of the ion being determined. Both ISE and the outer reference electrode must be specified. When an isothermal cell is used with identical reference electrodes, the isopotential point is defined by the activity of the sensed ions that gives zero net \rightarrow *membrane potential*, e.g., sensed activity is the same in the inner and outer (test) solution. Calibration lines for different cell temperatures have different slopes, but they intersect at a common activity point. Cells with temperature gradients are not recommended.

In multiscan cyclic voltammetry measurements, e.g., of a redox film-coated electrode, the isopotential point is the potential of the same current value for voltammograms of different cycles. That is, by analogy to, e.g., the isosbestic point in absorption spectroscopy of two species remaining in equilibrium, this is the potential at which voltammograms of two redox species being in equilibrium in the film cross each other. A pair of such redox species can have several isopotential points in their multicyclic voltammograms.

Refs.: [i] Buck RP, Lindner E (1994) *Pure Appl Chem* 66:2531; [ii] IUPAC *Compendium of chemical terminology*, 2nd edn. (1997)

WK

Isotachopheresis — (Greek: iso = equal, tachos = speed, phoresis = migration) A separation technique using a discontinuous electrical field to create sharp boundaries between sample constituents. In conventional \rightarrow *electrophoresis* the electric current is carried mostly by the buffer electrolyte. The sample constituents migrate under the influence of a homogeneous electrical field. The buffer determines the pH of the medium as well as the degree of dissociation of the sample constituents according to their pK values. The sample constituents migrate at different speeds and become diluted by diffusion. Preparation of the sample is often necessary to concentrate the sample elements before application. The sample is introduced between a fast leading electrolyte and a slow terminating electrolyte. After application of an electric potential a low electrical field is created in the leading electrolyte and a high electrical field in the terminating electrolyte. The pH at sample level is determined by the counter ion of the leading electrolyte that migrates in the opposite direction. In a first stage the sample constituents migrate at different speeds and start to separate from each other. The faster constituents will create a lower electrical field in the leading part of the sample zone and vice versa. Finally the constituents will completely separate from each other and concentrate at an equilibrium concentration, surrounded by sharp electrical field differences. Specific spacer or marker molecules are added to the sample to separate physically the sample constituents one is interested in.

Refs.: [i] Everaerts FM (1976) *Isotachopheresis*. Elsevier, Amsterdam; [ii] Townshend A (ed) (1995) *Encyclopedia of analytical science*. Academic Press, New York, 1075

RH

Isothermal temperature coefficient — $(dE/dT)_{\text{isoth}}$ is the derivative of the \rightarrow *electromotive force* with respect to the temperature for the following isothermal cell [i]:



where the left-hand-side cell is the \rightarrow *standard hydrogen electrode*. The temperature of the whole cell is varied in the same manner simultaneously. See also \rightarrow *thermal temperature coefficient* and \rightarrow *temperature coefficient*.

Ref.: [i] deBethune AJ, Licht TS, Swendeman N (1959) *J Electrochem Soc* 106:616

MBS

Isotonic \rightarrow *osmosis*

ITIES \rightarrow *interface of two immiscible electrolyte solutions*

J

Jacobi, Moritz Hermann von



(Photo 1856)

(Sep. 21, 1801, Potsdam, Germany – Mar. 10, 1874, St. Petersburg, Russia) Jacobi was a German physicist and engineer who worked mainly in Russia on practical applications of electricity. His research on electromagnets and their applications in electro-generators and electro-motors was of great practical importance [i]. In 1834 he designed one of the first electro-motors and in 1839 he constructed a 28-ft boat propelled by an electric motor with a large number of battery cells. It carried 14 passengers on the Neva River, St. Petersburg, at a speed of three miles per hour. In 1838, Jacobi developed → *galvanoplastics* (also called electrotyping) [ii] – the method for making duplicate plates for relief, letterpress, or printing. He also contributed to the development of wire telegraphy.

Refs.: [i] Jacobi MH (1835) *Mémoire sur l'application de l'électromagnétisme au mouvement des machines*. Eggers et Cie, Sankt Petersburg; [ii] Jacobi MH (1840) *Die Galvanoplastik*. Eggers et Cie, Sankt Petersburg

EK

Jacobi current strength (intensity) — Obsolete definition of the strength of current. → *Jacobi* has suggested to use as a unit of current strength that current which produces 1 cm³ of detonating gas (oxygen-hydrogen mixture) in one minute (under dry conditions, at 0 °C, and 760 mmHg pressure).

FS

Jander, Gerhart



(Universitätsarchiv, Technische Hochschule Berlin)

(Oct. 26, 1892, Alt-Döbern, Germany – Dec. 12, 1961, Berlin, Germany) Jander studied chemistry from 1912–1917 in Munich and Berlin, where he received his Ph.D. in 1917. From 1918–1922 he was assistant of → *Zsigmondy* in Göttingen, where he habilitated in 1921 for inorganic chemistry. In 1933/34 he was deputy director of the Kaiser-Wilhelm-Institute of Physical Chemistry in Berlin (the position was vacant because the Nazis forced the former director → *Haber* to leave). Jander had the chair of chemistry at the University of Greifswald from 1935–1951, and from 1951 to 1960 he was director of the Institute of Inorganic Chemistry at the Technical University of Berlin (West-Berlin). Jander is known for his work on → *electrolytes*, nonaqueous → *solvents*, and development of → *conductometric titration*. He contributed to the → *acid-base theories* by advocating a generalized solvo-acid–solvo-base theory.

Ref.: [i] Jander G (1949) *Die Chemie in wasserähnlichen Lösungsmitteln*. Springer, Berlin

FS

Jellium model — Jellium is a simple model for metals: The charge on the metal ions is smeared into a constant positive background charge, which drops to zero at the surface; the electrons are treated within density-functional theory. Due to their small mass the electrons spill over the surface into the adjacent phase, and their density responds to an external field. Jellium has been used as a model for the metal in → *double-layer* theory in order to explain the dependence of the interfacial capacity on the nature of the metal.

Refs.: [i] Badiali JP, Goodisman J, Rosinberg M (1983) *J Electroanal Chem* 143:73; [ii] Schmickler W (1983) *J Electroanal Chem* 150:19; [iii] Schmickler W, Henderson D (1986) *Prog Surf Sci* 22:323

WS

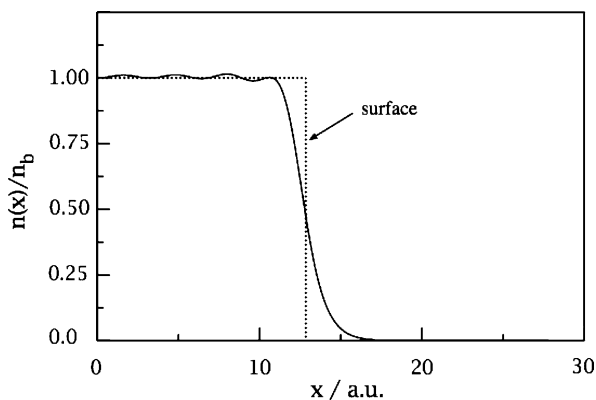

Jellium model — Figure. Normalized electronic density $n(x)$ near the jellium surface (full line); n_b is the bulk density

Jost, Wilhelm Friedrich



(June 15, 1903, Friedberg, Hessen, Germany – Sep. 23, 1988, Göttingen, Germany) Jost studied chemistry at the University of Halle from 1921–1926 (partly also in Munich). In 1926 he received his Ph.D. in Halle, and from 1926 to 1929 he was private assistant to M.E.A. Bodenstein in Berlin. In 1929 he habilitated in Hannover, and in 1932/33 he worked at the MIT, Cambridge. In 1937 he was appointed Professor of Applied Physical Chemistry at the University of Leipzig, Germany. He held Professor positions at the University of Marburg (1943–51), at TH Darmstadt (1951–53), and Göttingen (1953–1968). Jost contributed to various fields of physical chemistry; however, for electrochemistry his work on → *diffusion in*

solids is most important. In that field he published two important books [i, ii].

Refs.: [i] Jost W (1957) *Diffusion. Methoden der Messung und Auswertung*. Steinkopf, Darmstadt; [ii] Jost W (1960) *Diffusion in solids, liquids, gases*, 3rd edn. Academic Press, New York

FS

Joule, James Prescott



(Dec. 24, 1818, Salford, Greater Manchester, Great Britain – Oct. 11, 1889, Sale near Manchester, Great Britain) Joule studied the nature of heat and its relationship to mechanical work (mechanical equivalent of heat) at Manchester University under John Dalton, developed the first law of thermodynamics, made observations on magnetostriction, found the relationship between electrical current flowing through a resistor and the dissipated heat (Joule's law 1840). Between 1852 and 1862 he studied with William Thomson (later Lord Kelvin) the expansion of gases and discovered the effect later named Joule–Thomson effect. The SI unit of energy (→ *SI derived units*) was named after him to honor his accomplishments.

Refs.: [i] Crystal D (ed) (1998) *The Cambridge biographical encyclopedia*. Cambridge University Press, Cambridge; [ii] Laidler KJ (1995) *The world of physical chemistry*. Oxford University Press, Oxford; [iii] Joule JP (1841) *Philos Mag* 19:260; [iv] Joule JP (1843) *Proc R Soc* 4:280

RH

Joule's law → *power (electrical)*

Junction potential → *liquid–junction potential*

K

Kabanov, Boris Nikolaevich



(May 28, 1904, Moscow, Russia – Aug. 12, 1988, Nikolina Gora, Moscow region, USSR, now Russia) graduated from the Chemistry Faculty of the Moscow State University in 1930; worked at the Karpov Institute of Physical Chemistry, the Institute of Physical Chemistry of the Soviet Academy of Sciences, and later at the Frumkin Institute of Electrochemistry. Kabanov contributed to many fundamental areas of electrochemistry, including the analysis of various interfacial processes at solid and liquid → *electrodes*, anodic dissolution and → *passivation* of metals, → *corrosion*, → *electrochemical machining*, and → *electrode reactions* in chemical → *power sources*. He studied the phenomenon of electrochemical incorporation of alkaline metals forming chemical compounds with → *cathode* materials via a single-stage electrochemical reaction. This phenomenon, understood presently in framework of the → *insertion electrochemistry* concepts, is sometimes considered as having both distinctive and common features with respect to → *underpotential deposition* and → *intercalation* processes. Kabanov contributed also in the determination of zero-charge potential (→ *point of zero charge*) of various solid electrodes, analysis of hydrogen overvoltage at very high → *current densities*, developments of → *lead–acid* and *silver–zinc* → *batteries*.

Refs.: [i] Kabanov BN (1966) *Electrokhimiya metallov i adsorbt-siya* (The electrochemistry of metals and the adsorption). Nauka, Moscow; [ii] Frumkin AN, Bagotsky VS, Iofa ZA, Kabanov BN (1952) *Kinetika elektrodnykh protsessov* (Kinetics of electrode processes). Moscow State University Publ., Moscow; [iii] Davydov AD, Pleskov YuV, Grafov BM, Leikis DI (2004) *Russ J Electrochem* 40:1227

Kaishev (Kaischew), Rostislav Atanasov



(Feb. 29, 1908, Sankt Petersburg, Russia – Nov. 19, 2002, Sofia, Bulgaria) Kaishev was born in Russia where his father was at that time at the Russian General Staff Academy. He graduated with a diploma in chemistry from Sofia University in 1930. As a Humboldt fellow he was in Germany (Berlin and Breslau) and obtained his Ph.D. degree from Technische Hochschule zu Breslau under the supervision of Franz Simon (1893–1956) in 1932 [i, ii].

He started to work at the Chemical Faculty of Sofia University where he became a professor and the head of the Department of Physical Chemistry, in 1947. Kaishev founded the Institute of Physical Chemistry of the Bulgarian Academy of Sciences in 1958, and helped to establish the Central Laboratory of Electrochemical Power Sources [i]. Kaishev started to collaborate with → *Stranski* in Berlin in 1931 [iii] and became his assistant in Sofia in 1933. They laid the fundamentals of the crystal growth theory. They proposed the first kinetic theory of the two-dimensional → *nucleation* and growth. The spiral type growth during → *electrocrystallization* was first observed by Kaishev on silver [iii]. On the history of the creation of the molecular-kinetic theory of crystal growth see [iv].

Refs.: [i] Milchev A, Stoyanov S (2002) *Academician Rostislav Kaishev – a life dedicated to science*. Academic Publisher 'Marin Drinov', Sofia, (in Bulgarian); [ii] Kaischew R (1932) *Thermische Untersuchungen am festen und flüssigen Helium* (Thermal studies of solid and liquid helium). PhD thesis, TH Breslau; [iii] Stranski IN, Kaishev R (1931) *Z Kristallogr* 78:373; [iii] Kaischew R, Budevski E, Malinowski J (1955) *Z phys Chem* 204:348 [iv] Kaischew R (1981) *J Cryst Growth* 51:643

GI

Kalousek, Mirko



K

(June 19, 1915, Nakhchivan, Russian Empire, now Naxçıvan Autonomous Republic (part of Azerbaijan) – Aug. 8, 1996, Prague, Czech Republic) Kalousek was an assistant of → Heyrovský with whom he made his Ph.D. Kalousek habilitated in Physical Chemistry on May 1, 1951, and became Professor of Physical Chemistry at Charles University, Prague, on March 1, 1960. Kalousek invented an ingenious glass cell for performing → polarography: Its main feature was that a reference electrode serving as counter electrode, was separated from the polarographic cell by an electrolyte bridge using a glass cock (see Fig.). In his dissertation in 1939 he dealt with the topic of reversibility of polarographic reactions in reductions of various metallic ions [i] and in oxidations of dilute amalgams [ii], which inspired him to construct

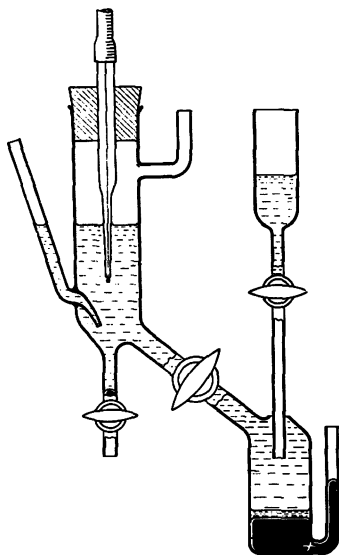

Kalousek, Mirko — Figure. Polarographic cell designed by M. Kalousek

an electrochemical commutator [iii] that bears his name (→ *Kalousek commutator*).

Refs.: [i] Kalousek M (1939) *Coll Czech Chem Commun* 11:592; [ii] Kalousek M (1940) *Chem Listy* 24:47 (CA 34, 5761); [iii] Kalousek M (1948) *Coll Czech Chem Commun* 13:105

FS, MHey

Kalousek commutator — In 1946 Mirko → *Kalousek* constructed an instrument with a rotating commutator that switched the → *potential* of the → *dropping mercury electrode* between two voltage levels with a constant frequency [i]. At the lower level the reactant was reduced and at the higher level the product of reduction was oxidized. The switching rate was five cycles per second, and the current was recorded during the higher potential half-cycles. The method was developed to study the → *reversibility* of → *electrode reactions* and to investigate → *electroactivity* and other properties of intermediates. Kalousek devised three methods for programming the voltages applied to the dropping mercury electrode [ii]. These methods have been designated as types I, II, and III. Type I polarograms were recorded by superimposing a low-amplitude square-wave (20–50 mV) onto the ramp voltage of conventional → *polarography*. The response was a bell-shaped current-voltage curve similar to the backward component of the modern → *square-wave voltammogram*. In type II the lower potential level was constant and well into the → *limiting current* region and the voltage was alternated between this fixed value and the ramp potential. The response was a DC polarogram with both the oxidation and reduction limiting currents. The type III was devised to inspect intermediates of electrode reactions. In this type the ramp potential was crossing the fixed potential. The response recorded at the ramp potential showed the oxidation of the intermediate if the ramp potential was higher than

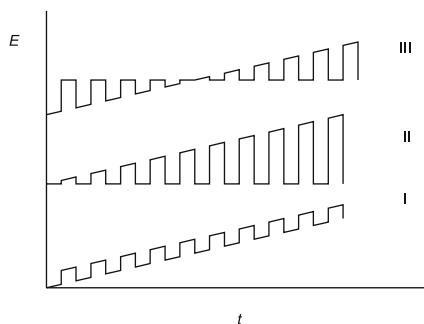

Kalousek commutator — Figure. Potential-time relationships of Kalousek commutator

the fixed potential, and the reduction of the intermediate if the ramp potential was lower than the fixed potential.

Refs.: [i] Kalousek M (1946) *Chem Listy* 40:149; [ii] Kalousek M (1948) *Collect Czech Chem Commun* 13:105

MLo

Kanevskii's scale → *potential*, → *absolute potential*

Kelvin (William Thomson, Baron Kelvin of Largs)

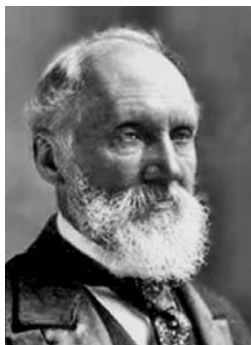

(26 June 1824, Belfast, County Antrim, Ireland, now Northern Ireland – 17 Dec. 1907, Largs, Ayrshire, Scotland, UK) His father, James Thomson (1786–1849) was Professor of Mathematics at the Belfast Academical Institution. He registered at Glasgow University at the age of ten! In 1841 William Thomson went up to the ancient college of Peterhouse, Cambridge. There he soon revealed his exceptional physical and mental powers. On leaving Cambridge in 1845 he spent some time at → *Faraday's* laboratory at the Royal Institution in London and at Regnault's laboratory at the Collège de France in Paris. During these visits Thomson developed an interest in the theory of dielectrics, and at the age of 21 astonished the world of physics by describing his “method of images” [i], which allowed the precise determination of the electric field surrounding a point charge, even when it is perturbed by a nearby spherical or planar conductor. Shortly thereafter he announced the discovery of a mathematical technique for transforming a harmonic function inside the unit sphere into a harmonic function outside the unit sphere [ii], now generally known as the “Kelvin transformation”. The following year (1846) he was appointed to the Chair of Natural Philosophy at the University of Glasgow. In 1848, in another *tour de force*, he proposed a thermodynamic scale of temperature [iii]. This implied the existence of an absolute zero of temperature. By February 1851 he had arrived at the second law of thermodynamics [iv], although he cannot claim sole credit for this, since the idea was “in the air”. (Other versions of the second law emerged contemporaneously

from the fertile minds of Clausius, → *Helmholtz*, → *Joule*, *Liebig*, and *Rankine*.) In 1852 he discovered the “Joule–Thomson Effect” in collaboration with Joule [v]. This led, ultimately, to the development of industrial-scale refrigeration. In 1855–56 he derived, and solved, the “Telegraph Equation” [vi, vii] and pointed out the “law of squares” which states that the delay in a → *transmission line* is proportional to the square of its length. This was crucially important in the design of telegraph cables. In December 1856, Thomson was invited to join the board of directors of the Atlantic Telegraph Company. He developed a complete electrical system for operating a submarine telegraph. This included a mirror galvanometer (1858) and a siphon recorder (1867), the latter anticipating the modern ink-jet printer. Later, he invented a balance for the precise specification of the → *Ampère*, and he investigated many aspects of hydrodynamic flow, including wave-motion and vortex-motion [viii]. Thomson received many awards during his lifetime, including Fellowship of the Royal Society (1851), a Knighthood (1866), the Copley Medal (1883), Prussian Orden Pour le Mérite (1884), the Barony of Largs (1892), and the Order of Merit (1902). The → *SI unit* of temperature, the kelvin (symbol K), is named in his honor.

Refs.: [i] Thomson W (1845) *J Math Pure Appl* 10:364; [ii] Thomson W (1847) *J Math Pure Appl* 12:256; [iii] Thomson W (1848) *Math and Phys Papers*, vol. 1. pp 100–106; [iv] Thomson W (1851) *Math and Phys Papers*, vol. 1. p 175; *Ibid* p 179; *Ibid* p 183; [v] Joule JP, Thomson W (1856) *Proc R Soc London* 78; [vi] Thomson W (1855) *Proc R Soc London* 61; [vii] Thomson W (1856) *Proc R Soc London* 299, 303; [viii] Thomson W (1856) *Math and Phys Papers*, vol. 1, pp 333–455

SF

Kelvin probe — The surface (or contact) potential of a solid or a liquid-film covered solid can be measured with a Kelvin probe [i]. Essentially the → *Volta potential difference* $\Delta\Psi$ between the two employed surfaces as described below is measured. In common abbreviation this is also called measurement of a Volta potential Ψ . As depicted below a probe tip is brought close to the surface under investigation.

The tip and the adjacent surface form a capacitor. When the distance between tip and surface is changed by vibrating the probe an AC current flows; its magnitude depends on the existing potential difference. By adjusting the external bias voltage U_{comp} this potential difference can be compensated, as a consequence the AC current vanishes. In most cases relative changes of the local surface potential are of interest. In order to remove any unwanted influence of the probe surface potential a material with constant surface potential is used (typically an

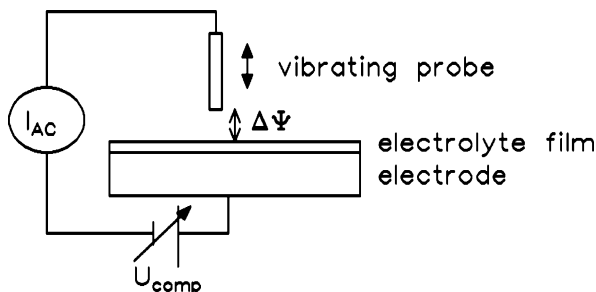

Kelvin probe — Figure. Scheme of Kelvin-probe measurement

K

etched Ni/Cr wire tip or a cylindrical probe of this material), thus the measured local Volta potential depends only on the surface potential of the sample. A calibration of the probe is accomplished by measuring the \rightarrow corrosion potential with a conventional \rightarrow reference electrode touching the electrolyte film-covered surface under investigation with a \rightarrow Luggin-capillary [ii]. Simultaneous measurements with a Scanning Kelvin Probe (SKP) yield the desired Volta potential difference, which differs from the measured corrosion potential only by a constant difference typical of the experimental setup. The Volta potential is thus closely and directly related to the local corrosion potential. Thus spatially resolved measurements are useful in studies of localized processes like, e.g., corrosion on heterogeneous surfaces. The required resolution can be obtained with piezodrives. The required compensation voltages are high enough to cause faradaic processes in aqueous solution in the gap between tip and surface, obviously this method will work only in the absence of bulk solution. It works well with thin electrolyte solution films coating the corroding surface under investigation as frequently encountered in atmospheric corrosion. In its described setup the distance between the tip (needle) and the surface is kept constant on a macroscopic level. In case of very rough, bent, or otherwise deformed surfaces this might prove insufficient. A mode of operation with a height-regulated probe has been proposed (HR-SKP) [iii].

Refs.: [i] Kelvin L (1898) *Philos Mag* 46:82; Adamson AW (1990) *Physical chemistry of surfaces*. Wiley, New York; [ii] Stratmann M, Streckel H (1990) *Corros Sci* 30:681; [iii] Wapner K, Schoenberger B, Stratmann M, Grundmeier G (2005) *J Electrochem Soc* 152:E114

RH

Kemula, Wiktor



(Mar. 6, 1902, Ismail, Bessarabia, Russian Empire, now Ukraine – Oct. 17, 1985, Warsaw, Poland) Kemula studied at Lwów University and there became professor of chemistry in 1936. From 1945 till 1968 Kemula has been Head of the Department of Inorganic Chemistry at Warsaw University. From 1968, after he was forced to leave the University, he led the laboratory of Physicochemical Analysis at the Institute of Physical Chemistry, Polish Academy of Sciences, Warsaw, and retired in 1980. Kemula's research spectrum was very broad; however, the main accent was given to the development of \rightarrow polarography. The invention of chromatopolarography and the construction of \rightarrow hanging mercury drop electrode (HMDE) are seen as his most important achievements. Chromatopolarography is a combination of chromatography with polarographic detection. The eluent leaving the polarographic column enters a polarographic cell and the consecutive analytes can be determined amperometrically. The term 'chromatopolarography' is obsolete as the mercury electrodes, especially the dropping mercury electrode, are not anymore employed for detection in liquid chromatography. However, amperometric detection with solid electrodes became an important analytical tool in HPLC (high performance liquid chromatography) and \rightarrow electrophoresis. The HMDE allowed the advance of \rightarrow cyclic voltammetry, amalgam electrochemistry, and \rightarrow anodic stripping voltammetry. Kemula was the founder of a famous electrochemistry school in Warsaw (see also \rightarrow Kublik). He also served as: vice-Rector of Warsaw University, Chairman of the Warsaw Scientific Society and Chairman of the Polish Chemical Society. He also served as Editor-in-Chief of the *Polish Journal of Chemistry* and *Chemia Analityczna*.

Ref.: [i] Hulanicki A (2002) *Chem Anal (Warsaw)* 47:U3–U5

ZS

Kemula electrode → hanging mercury drop electrode

Kiesele cell → electrochemical cell that may be used for → voltammetry, → coulometry, and → electrosynthesis in superdry aprotic media. Its essential feature is an internal drying column which contains activated alumina as superdrying agent and allows repetitive filtrations of the solution at low temperatures in a tightly closed and grease-free system.

Ref.: [i] Kiesele H (1981) *Anal Chem* 53:1952

JH

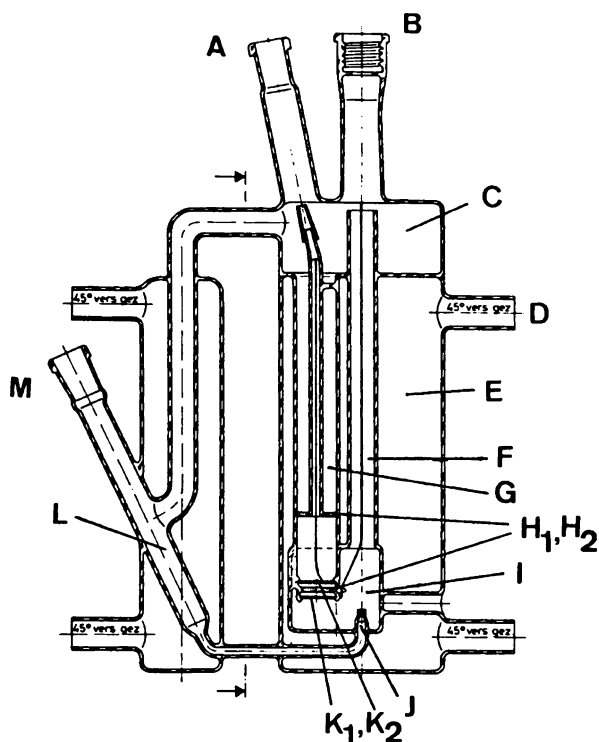

Kiesele cell — **Figure.** Kiesele cell: A: connection to a vacuum line; B: adjustable electrode adapter for combined auxiliary and working electrode; C: cell top that contains electrolytic solution during drying operation; D: connection to a cryostat; E: coding jacket; F: column connecting cell top and measuring compartment; G: drying column (filled with alumina); H₁, H₂: auxiliary and working electrodes for large scale electrolysis; I: working compartment in voltammetric or large-scale experiments; J: Luggin tip; K₁, K₂: quartz frits; L: reference electrode compartment; M: standard joint for reference electrode

Kinetic current → current, subentry → kinetic limiting current. See also → pre-equilibrium

Kinetic parameter — Also known as a “dimensionless kinetic parameter”. Any dimensionless combination of

physical parameters which includes a rate constant: homogeneous first-order ($k_1: s^{-1}$), homogeneous second-order ($k_2: M^{-1} s^{-1}$), heterogeneous ($k: cm s^{-1}$): e.g., $k_1 t$, $k_1 r_0^2/D$, $k_1 c t$ (where c is usually the bulk concentration of a designated reference species, most often the bulk concentration of the analyte), $k/\sqrt{FDv/RT}$, kr_0/D . Dimensionless parameters in general are invaluable for the efficient presentation of data and become the essential variables in any computation [i–iii]. Furthermore, dimensionless parameters by themselves can often lead to useful quantification of experimental behavior even in the absence of detailed mathematical or computational analysis.

Refs.: [i] Bond AM (2002) *Broadening electrochemical horizons*. Oxford University Press, Oxford, pp 95–100; [ii] Bard AJ, Faulkner LR (2001) *Electrochemical methods*, 2nd edn. Wiley, New York, pp 788–790; [iii] Oldham KB, Myland JC (1994) *Fundamentals of electrochemical science*. Academic Press, San Diego, pp 427–430

AMB

K

Kinetics — In classical terms reaction kinetics refers simply to the measurements of rates of chemical reactions. The overall reactions usually take place via series of elementary reactions. Therefore, the understanding of the molecular mechanism for a reaction – which is called reaction dynamics – is of primary importance. There is a strong link between the rate of reactions and dynamics of the reactions. Major developments in experimental techniques have allowed to take significant steps forward in the understanding of the detailed mechanism of both the elementary and complex reactions [i]. The velocity of the reactions can be influenced by a variation of the conditions, e.g., with an increase or decrease in temperature (see → Arrhenius equation). Electrochemical reactions involve charged species whose energy depends on the potential of the phase containing these species [ii, iii]. The essential step of electrochemical reactions is the transfer of charged species (ions or electrons) across the interface of two adjacent phases. The rate of this process is related to the potential difference between these phases. This potential difference can conveniently be varied; therefore at least within certain limits, we can regulate the reaction rate. If one of the electrodes is at equilibrium (two-electrode arrangement), or a separate → reference electrode is used (→ three-electrode system), we can investigate a given → electrode reaction at the → working electrode.

In electrochemistry the → reaction rate can be determined by the measurements of the → current flowing in the electrical circuit. Because the current is proportional to the → surface area of the electrode, in order to char-

acterize the rate of the reaction, the \rightarrow *current density* (j) is used. The relationship between the current density and the reaction rate related to unit surface area (v) is as follows:

$$j = nFv \quad (1)$$

where n is the \rightarrow *charge number* of the electrochemical cell reaction and F is the \rightarrow *Faraday constant*. The fundamental equation of electrode kinetics that describes the relationship between the current density and the \rightarrow *electrode potential* is the \rightarrow *Butler–Volmer equation*. The rate of the electrode processes depends on the rate of the electrode reaction and the \rightarrow *mass transport processes*. The rate of the electrode reaction also depends on the rate of several processes, such as the rates of the \rightarrow *charge transfer step*, structural reorganization, \rightarrow *adsorption*, \rightarrow *chemical reactions*. See also \rightarrow *Erdey-Grúz, T.*, \rightarrow *Ostwald F. W.*, \rightarrow *Hoff, J.H. van't*, \rightarrow *Volmer, M.*, \rightarrow *Wilhelmy, L.F.* For the history of chemical kinetics see [iv].

Refs.: [i] Pilling MJ, Seakins PW (1995) *Reaction kinetics*. Oxford Science Publications, Oxford; [ii] Inzelt G (2002) *Kinetics of electrochemical reactions*. In: Scholz F (ed) *Electroanalytical methods*. Springer, Berlin, pp 29–47; [iii] Bard AJ, Faulkner LR (2001) *Electrochemical methods*, 2nd edn. Wiley, New York, pp 87–155; [iv] Laidler KJ (1985) *Arch Hist Exact Sci* 32:43

Kink position \rightarrow *half-crystal position*

Klemensiewicz, Zygmunt Aleksander



(Reproduced with permission of 'Archiv der Max-Planck-Gesellschaft, Berlin-Dahlem')

(June 24, 1886, Krakau, Austro–Hungarian Empire, now Kraków, Poland – Mar. 25, 1963, Gliwice, Poland) Klemensiewicz studied chemistry, physics, and mathematics at the University of Lemberg (now Lviv, Ukraine), where he graduated in 1908. From 1908 to 1911 he worked at the 'Technische Hochschule' (technical university) in Karlsruhe with \rightarrow *Haber* studying the potential drop across thin glass membranes, leading finally to the development of the \rightarrow *glass electrode* [i]. Shortly afterwards,

he presented an exhaustive treatment of the methods used in the study of critical phenomena [ii]. Klemensiewicz habilitated in 1912 at the University of Lemberg (now Lviv). In 1913 he got a scholarship from the Carnegie–Curie Foundation and worked in Paris with Maria Skłodowska-Curie on the electrochemistry of radioactive elements, and from 1914 to 1917 he worked in Paris at the Pasteur Institute. From 1920 to 1940 he was Professor in Lemberg. In 1940, he was arrested by the Soviet Secret Police and deported to the Kazakh Republic of USSR. In 1942 he could leave the USSR via Iran to Egypt. Between 1947 and 1951 he was a co-organizer of the Polish Polytechnic, later Polish University College in London. During 1951–1956 he lived in Beckham near London continuing his scientific interests. From 1956 to 1960 he was the chair of nuclear physics at the Silesian University of Technology in Gliwice. In his scientific career he published approx. 50 papers in electrochemistry, radioactivity, kinetics, and thermodynamics.

Refs.: [i] Haber F, Klemensiewicz ZA (1909) *Z phys Chem* 67:385; [ii] Klemensiewicz ZA (1912) *Kritische Größen*. In: Stähler A (ed) *Stählers Handbuch der Arbeitsmethoden in der anorganischen Chemie*, vol. 3. Berlin, pp 193–238; [iii] <http://info.ifpan.edu.pl/ON-1/Historia/klemensiewicz.htm>

HK

GI Knudsen cell — A technical or electrochemical device that generates a strictly controlled effused beam of a desired gas, usually for the purpose of performing chemical reactions or for physicochemical characterizations. An electrochemical Knudsen cell uses galvanic current to generate the desired chemical species. The specified flux conditions are reached by selecting optimal gasification temperature and electrolysis current. Electrochemical Knudsen cells usually consist of two solid electrodes, separated by solid-state ionic conductor electrolyte. Typically these cells operate at elevated temperatures, both to impart acceptable ionic conductivity to the solid-electrolyte, and to assure stable gas effusion. For example, stable, small flux of S_2 vapors is obtained in an electrochemical Knudsen cell of the type: $^-Pt|Ag|AgI|Ag_2S|Pt^+$ at high temperature (scheme *vide infra*). External polarization results in removing Ag^+ from Ag_2S by solid-state electrolysis, accompanied by anodic oxidation of S^{2-} to S^0 which sublimates as S_2 . Control of the cell temperature and the electrolysis current results in controlled effused beam of the desired S_2 gas.

The cell was named after Martin Hans Christian Knudsen (Feb. 15, 1871 – May 27, 1949), a Danish physicist who taught and conducted research on molecular gas flow at the Technical University of Denmark.

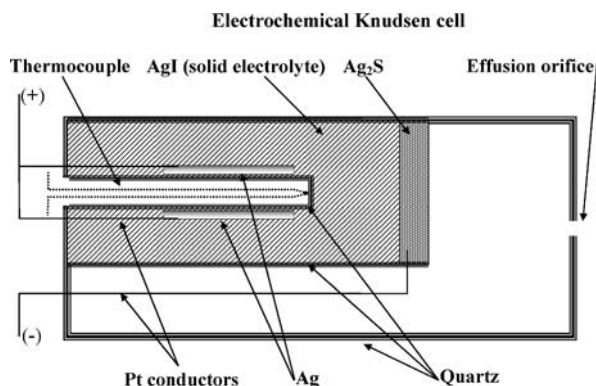

Knudsen cell — Figure

Refs.: [i] Steudel R (2004) *Series: Topics in current chemistry*, vol. 231. *Elemental sulfur and sulfur-rich compounds II*. Springer, p 89; [ii] Takemiko T (1989) *High conductivity solid state conductors – recent trends and applications*. World Scientific Publishing, Singapore, p 672

ML

Knudsen coefficient — The term relates to a particular type of mass transfer of gases through the pores of a specific porous medium. The gas transport characteristics depends on the ratio of the mean free path for the gas molecule, λ , to the pore diameter, d_{pore} , which is called the Knudsen number, Kn ($\text{Kn} = \frac{\lambda}{d_{\text{pore}}}$). In the continuum region, the mean free path of the gas molecules, is small compared with the pore diameter, and hence molecule–molecule collisions predominate over molecule–wall collisions ($\text{Kn} \ll 1$). As a result, a gradient in the gas pressure leads to a viscous flow (Darcy’s law). In contrast, in the Knudsen region $\text{Kn} \gg 1$, in which molecule–wall collisions predominate over molecule–molecule collisions, the mass transport driven by the pressure gradient can be expressed by Knudsen’s law. At a given temperature (T), the flux of gas through a porous body in the Knudsen region, J_{kn} , is proportional to the pressure gradient, ∇p , with the effective Knudsen coefficient, D_{kn} : $J_{\text{kn}} = -\frac{D_{\text{kn}}}{kT} \nabla p$. Knudsen coefficient depends linearly on d_{pore} : $D_{\text{kn}} = \frac{4d_{\text{pore}}\epsilon_p}{3\mu_p} \left(\frac{kT}{2\pi M}\right)^{\frac{1}{2}}$ (where ϵ_p stands for porosity, μ_p tortuosity factor, M molecular weight of the gas). This is in contrast to the case of continuous flow of gas through a porous body with permeability proportional to the square of the mean pore diameter, d_{pore} , so that the viscous flow (J_{vis}) is expressed by the Darcy–Poiseuille’s law: $J_{\text{vis}} = -\frac{\epsilon_p d_{\text{pore}}^2}{\mu_p 32\eta} c \nabla p$, where c denotes molar density of the gas, and η its dynamic \rightarrow viscosity.

Refs.: [i] Kasta W, Hohenthannerb CR (2000) *Heat Mass Transfer* 43:807–823; [ii] Bird RB, Stewart WE, Lightfoot EN (1976) *Transport phenomena*. Wiley, New York; [iii] Knudsen M (1909) *Ann Phys* 29:179
ML

Kohlfürst cell — This was a variant of the \rightarrow Daniell cell. See also \rightarrow zinc, \rightarrow Zn^{2+}/Zn electrodes, \rightarrow $\text{Zn}^{2+}/\text{Zn}(\text{Hg})$ electrodes, \rightarrow zinc–air batteries (cell), and \rightarrow Leclanché cell.

Ref.: [i] Hauck WP (1883) *Die Galvanischen Batterien, Accumulatoren und Thermosäulen*, 2nd edn. Hartleben’s Verlag, Wien

FS

Kohlrausch, Friedrich Wilhelm Georg



(Oct. 14, 1840, Rinteln, Germany – Jan. 17, 1910, Marburg, Germany) He studied physics in Göttingen and Erlangen, doctorate in Göttingen in 1863, habilitation in Göttingen, professor in Göttingen 1867, 1870 in Zürich, 1875 in Würzburg where his students and co-workers were \rightarrow Nernst, Heydweiler and \rightarrow Arrhenius, 1894 president of the Physikalisch-Technische Reichsanstalt in Berlin-Charlottenburg, worked on numerous physical subjects including electrolytic \rightarrow conductivity, independent movement of ions (\rightarrow Kohlrausch square root law). The \rightarrow Kohlrausch-Walze has been applied to regulate the resistance in electrical circuits, until the 1960s.

Refs.: [i] Magnusson M (ed) (1990) *Chambers biographical dictionary*. W&R Chambers, Edinburgh; [ii] Crystal D (ed) (1998) *The Cambridge biographical encyclopedia*. Cambridge University Press, Cambridge

RH

Kohlrausch square root law — (1900) A plot of equivalent conductivity Λ^{eq} vs. square root of concentration $c^{1/2}$ according to

$$\Lambda^{\text{eq}} = \Lambda^0 - k\sqrt{c}$$

yields a straight line for strong (completely dissociated) electrolytes with Λ^0 being the equivalent conductivity

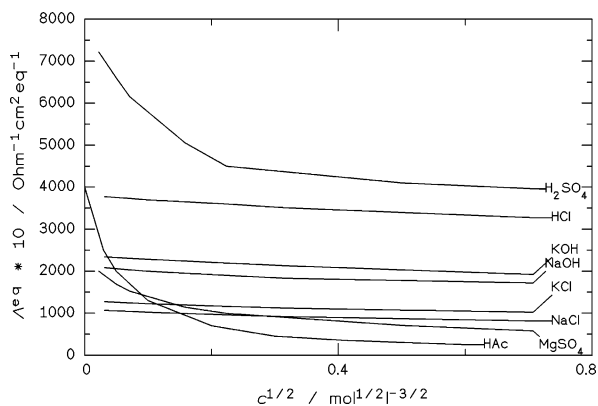

Kohlrausch square root law — Figure

Λ^{eq} at infinite dilution. For the theoretical explanation see \rightarrow Debye-Hückel-Onsager theory.

RH

Kohlrausch-Walze \rightarrow helical potentiometer

Kolbe, Adolf Wilhelm Herman



(Sept. 27, 1818, Elliehausen, near Göttingen, Germany – Nov. 25, 1884, Leipzig, Germany) Pupil of F. Wöhler and \rightarrow Bunsen, 1845–1847 assistant at the Museum of Economic Geology, London, UK (working with L. Playfairs), 1851 Professor in Marburg, Germany, since 1865 Professor in Leipzig, Germany [i]. Kolbe is famous for various contributions to organic chemistry. Although \rightarrow Faraday was possibly the first who electrolyzed acetate solutions, it was Kolbe who performed systematic studies of the electrolysis of aqueous solutions of organic salts (acetate, valeriante) [ii] and thus he is by some regarded as the father of organic electrochemistry. In the case of an acetate solution he supposed to have obtained the methyl radical. Later, A. Kekulé proved that the product was ethane [iii].

Refs.: [i] Remane H, Hantschmann A, Weiffenfels M (1984) *Z Chem (Leipzig)* 24:393; [ii] Kolbe H (1840) *Ann Chem Pharm* 69:257; [iii] Kekulé A (1864) *Ann Chem Pharm* 131:79

FS

Kolbe synthesis — The definition and use of the terms \rightarrow Kolbe synthesis, K. reaction, K. electrolysis, and K. process are not very clearly distinguished and often bear different nuances of meaning. Kolbe electrolysis or synthesis mainly accounts for the anodic oxidation of carboxylic acids or carboxylates, followed by a decarboxylation step, when concentrated aqueous solutions of the respective carboxylates are electrolyzed. Kolbe picked up earlier results from \rightarrow Faraday on the electrolysis of acetic acid or acetate solutions to CO_2 and ethane [i] and continued these experiments during 1843–1845 with further homologs as, e.g., valerianic acid [ii]. The carboxylate R-COO^- is anodically oxidized to form an unstable radical R-COO^\cdot , which is stabilizing via a decarboxylation reaction, leaving radical rest R^\cdot :



Eventually, the formed alkyl radical(s) dimerize forming an alkane R-R (with an even number of C atoms), if high current densities and high radical concentration are provided. The Kolbe synthesis can be used for the build-up of higher saturated hydrocarbons or fatty acids, or longer-chain diester compounds.

The Kolbe nitrile synthesis and the Kolbe-Schmitt reaction refer to nonelectrochemical syntheses.

Refs.: [i] Faraday M (1834) *Pogg Ann* 33:438; [ii] Kolbe H (1849) *Liebigs Ann Chem* 69:257

MHer

Kolbe cross-coupling or “mixed” Kolbe reaction —

When two different carboxylic acids A and B (carboxylate anions) are used, generally all three possible products (A-A, A-B, B-B) are formed. The yield of the mixed one (A-B) can be enhanced when one of the starting compounds is used in high excess. The main application: synthesis of natural products (e.g., pheromones).

Refs.: [i] Seidel W, Schaefer HJ (1980) *Chem Ber* 113:3898; [ii] Huh-tasaari M, Schaefer HJ, Beckung L (1984) *Angew Chem Int Ed Engl* 23:980; [iii] Muller N (1986) *J Org Chem* 51:263; [iv] Uneyama K, Watanabe S, Tokunaga Y, Kitagawa K, Sato Y (1992) *Bull Chem Soc Jpn* 65:1976

JL

Kolmogorov entropy — Entropy is related to the amount of information needed to locate a system in

a certain state. For the case of a chaotic dynamical system, the Kolmogorov entropy measures how chaotic the system is. Formally, it is defined in the following way: Consider the trajectory $\mathbf{x}(t)$ of a dynamical system in N -dimensional space, which is partitioned into cubes of size l^N . The state of the system is now observed at equally spaced time intervals of separation τ . Let $P_{i_0 \dots i_n}$ denote the joint probability that $\mathbf{x}(t = 0)$ is in the box i_0 , $\mathbf{x}(t = \tau)$ is in the box i_1 , ... and $\mathbf{x}(t + n\tau)$ is in box i_n . The Kolmogorov entropy is then defined as:

$$K = -\lim_{\tau \rightarrow 0} \lim_{l \rightarrow 0} \lim_{n \rightarrow \infty} \frac{1}{n\tau} \sum_{i_0 \dots i_n} P_{i_0 \dots i_n} \log P_{i_0 \dots i_n}$$

It measures the average loss of information. For regular motion, $K = 0$, and for random motion $K = \infty$.

Refs.: [i] Kolmogorov AN (1959) *Dokl Akad Nauk* 81:527

WS

Kolthoff, Izaak Maurits (Piet)



(Courtesy of Michigan State University, Chemistry Department)

(Feb. 11, 1894, Almelo, Netherlands – Mar. 4, 1993, St. Paul, Minnesota, USA) Kolthoff greatly contributed to many areas of chemistry, particularly focusing on the theoretical background of analytical chemistry [i–iv]. He studied acid–base analysis, gravimetric analysis, volumetric analysis, iodometry, the theory of colloids and crystal growth, thereby establishing a scientific basis for gravimetry [v]. He developed the theory of potentiometric and conductometric titrations. His research transformed analytical chemistry from a collection of empirical recipes and prescriptions to a fundamental branch of modern chemistry [vi, vii]. Kolthoff started his studies in voltammetry in 1933 influenced by the visit of → *Heyrovský*, the inventor of → *polarography*. Two of Kolthoff's students were working on voltammetry, → *Lingane* on → *dropping mercury electrodes*, and → *Laitinen* on solid microelectrodes. Their studies were extremely important for the development of electroanalytical chemistry,

and the results were summarized in seminal review papers and books [viii–x].

Refs.: [i] *Lingane JJ* (1964) *Talanta* 11:67; [ii] *Laitinen HA* (1981) *Trends Anal Chem* 1:4; [iii] *Laitinen HA, Meehan EJ* (1984) *Anal Chem* 56:248A; [iv] *Laitinen HA, Hume DN, Jordan J, Bruckenstein S* (1989) *Anal Chem* 61:287A; [v] *Kolthoff IM* (1942) *Volumetric analysis*, 2nd edn. Interscience; [vi] *Kolthoff IM* (1969) *Quantitative chemical analysis*, 4th edn. Macmillan, New York; [vii] *Kolthoff IM* (1978) *Treatise on analytical chemistry*, 2nd edn. Wiley, New York; [viii] *Kolthoff IM, Lingane JJ* (1952) *Polarography*. Interscience, New York; [ix] *Kolthoff IM* (1941) *Polarography: polarographic analysis and voltammetry, amperometric titrations*. Interscience; [x] *Zuman P, Kolthoff IM* (1972) *Progress in polarography*. Wiley, New York

EK

Koryta, Jiří



(June 24, 1922, Písek, then Czechoslovakia – May 30, 1994, Prague, Czech Republic) Professor of physical chemistry at Charles University, leading scientific worker of the Polarographic Institute, Prague. Koryta studied processes at the mercury jet electrode [i–ii], the electrochemical behavior of complex compounds [iii], and the effect of adsorption of electroinactive compounds on electrode processes [iv]. Later he concentrated on processes at the interface of immiscible electrolyte solutions (→ *interface between two immiscible electrolyte solutions*, → *ion transfer at liquid–liquid interfaces*) [v, vi]. He co-authored a textbook on electrochemistry ([vii]), which was translated into several languages.

Refs.: [i] *Koryta J* (1954) *Coll Czech Chem Commun* 19:433; [ii] *Koryta J* (1955) *Coll Czech Chem Commun* 20:1125; [iii] *Koryta J* (1967) *Electrochemical kinetics of metal complexes*. In: *Delahay P* (ed) *Advances in electrochemistry and electrochemical engineering*, vol. 6. Interscience, New York, pp 289–327; [iv] *Koryta J* (1953) *Coll Czech Chem Commun* 18:206; [v] *Koryta J, Vanýšek P, Březina M* (1976) *J Elanal Chem* 67:263; [vi] *Koryta J* (1983) *Ion Sel Electrode Rev* 5:131; [vii] *Koryta J, Dvořák J, Boháčková V* (1970) *Electrochemistry*. Methuen, London

MHey

Kosmotropes → Hofmeister series

Kösters laser interferometer — The Kösters laser interferometer (Kösters-prism [i] interferometer) is a laser-illuminated double-beam interferometer. The main advantage of this type of interferometer (as represented schematically in Fig. 1) is its high immunity to environmental noise due to the close vicinity of the two interfering beams. This immunity makes it an ideal tool for high-precision measurements, e.g., for the determination of → *surface stress* changes (Δg) of solid electrodes.

The central constituent of the interferometer is the Kösters-prism beam splitter (KP), which produces two parallel coherent beams. Transparent samples may be inserted in region P1, while reflective samples will replace one or both reflecting mirrors (M1, M2) at position P2. The two reflected beams recombine in the prism, and an interference pattern is observed at the detector D. Kösters-prisms consist of two identical prism halves which are cemented together. The angles of the prism halves are 30° – 60° – 90° , with high angular accuracy, and one long cathetus side is semi-transparent (the reflection and transmission coefficients are equal).

Figure 2 shows the principle of electrochemical Kösters laser interferometry for the determination of changes of surface energy by the resulting deformation of an elastic plate. The height ΔZ_C of the center of the plate with respect to a plane at a given radius yields Δg from the appropriate form of Hooke's law

$$\Delta g = k \Delta Z_C$$

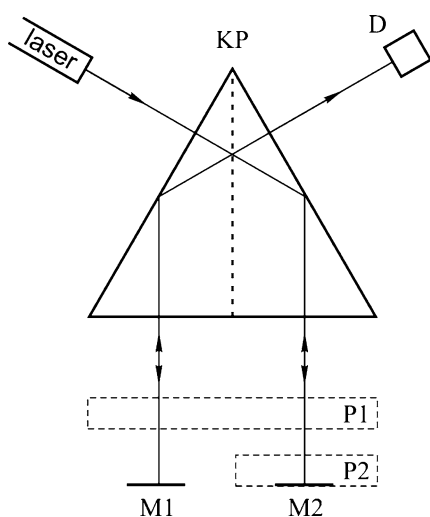

Kösters laser interferometer — Figure 1. The principle of the Kösters-prism interferometer

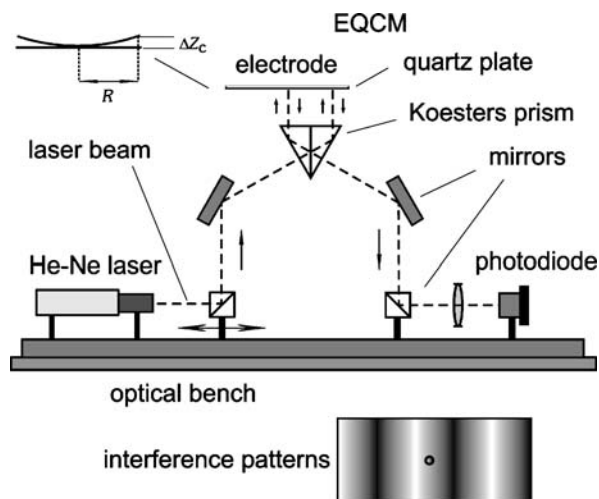

Kösters laser interferometer — Figure 2. Kösters laser interferometer setup for electrochemical experiments

Choosing a circular AT-cut quartz plate with a thin metal layer on it in contact with the solution being the working electrode in an electrochemical cell (→ *electrochemical quartz crystal microbalance, EQCM*) provides the advantage of measuring simultaneously surface energy, mass, and charge.

The constant k in the equation is determined completely by the mechanical properties of the quartz plate (radius R) and by the type and quality of the support at the edge of the plate. The sensitivity is of the order 0.1 nm with respect to ΔZ_C and 1 mN/m with respect to Δg [ii–iii].

If the electrodes on both sides of the quartz disk are connected to an oscillator circuit, frequencies f can be measured with a frequency counter. The changes of superficial mass can be calculated from changes of the frequency Δf using the Sauerbrey-equation (→ *quartz crystal microbalance*). Changes at the sensitivity level of 0.1 Hz at a fundamental frequency of 10 MHz correspond to a mass of about $0.4 \text{ ng} \cdot \text{cm}^{-2}$.

Refs.: [i] Kösters W (1934) *Interferenzdoppelprisma für Messzwecke*. German patent: 595211; [ii] Jaeckel L, Láng G, Heusler KE (1994) *Electrochim Acta* 39:1031; [iii] Láng GG, Seo M, Heusler KE (2005) *J Solid State Electrochem* 9:347

Koutecký, Jaroslav

(Courtesy of Vlasta Bonačić-Koutecký, Berlin)

(Oct. 14, 1922, Kroměříž, then Czechoslovakia – Aug. 10, 2005, Berlin, Germany) Koutecký was a theoretical electrochemist, quantum chemist, solid state physicist (surfaces and chemisorption), and expert in the theory of clusters. He received his PhD in theoretical physics, was later a co-worker of → Brdička in Prague, and since 1967 professor of physical chemistry at Charles University, Prague. Since 1973 he was professor of physical chemistry at Freie Universität, Berlin, Germany. Koutecký solved differential equations relevant to spherical → diffusion, slow electrode reaction, → kinetic currents, → catalytic currents, to currents controlled by nonlinear chemical reactions, and to combinations of these [i–v]. For a comprehensive review of his work on spherical diffusion and kinetic currents see [vi]. See also → Koutecký–Levich plot.

Refs.: [i] Koutecký J (1953) *Coll Czech Chem Commun* 18:183; [ii] Koutecký J (1954) *Nature* 174:233; [iii] Koutecký J, Čížek J (1956) *Coll Czech Chem Commun* 21:836, 1063; [iv] Koutecký J, Koryta J (1961) *Electrochim Acta* 3:318; [v] Brdička R, Hanuš V, Koutecký J (1962) *General theoretical treatment of the polarographic kinetic currents*. In: Zuman P, Kolthoff IM (eds) *Progress in polarography*, vol. 1. Interscience, New York London, pp 145–199; [vi] Čížek J (1987) *Prog Surf Sc* 25:17

MHey

Koutecký–Levich plot — The diffusion-limited current $I_{\text{lim,diff}}$ at a → rotating disk electrode is given by the → Levich equation based totally on mass-transfer-limited conditions. The disk current I_K in the absence of diffusion control, i.e., in case of electron transfer control, would be

$$I_K = FAk(E)c^*$$

with the surface area A of the electrode, the rate constant k as a function of the electrode potential E and the concentration c^* . A general equation of the disk current

taking into account both → mass transport and → electron transfer kinetics can thus be given as the Koutecký–Levich equation:

$$\frac{1}{I} = \frac{1}{I_K} + \frac{1}{I_{\text{lim,diff}}} = \frac{1}{I_K} + \frac{1}{0.62nFAD^{2/3}\omega^{1/2}\nu^{-1/6}c^*}$$

See also → Koutecký.

Ref.: [i] Bard AJ, Faulkner LR (2001) *Electrochemical methods*, 2nd edn. Wiley, New York

RH

Krafft temperature → critical micellisation concentration

K

Kramer cell — This was a variation of the → Daniell cell. See also → zinc, → Zn^{2+}/Zn electrodes, → $Zn^{2+}/Zn(Hg)$ electrodes, → zinc–air batteries (cell), and → Leclanché cell.

Ref.: [i] Hauck WP (1883) *Die Galvanischen Batterien, Accumulatoren und Thermosäulen*, 2nd edn. Hartleben's Verlag, Wien

FS

Kröger–Vink notation — is a conventional method to denote point → defects in solids and their associates. This method proposed by F.A. Kröger and H.J. Vink [i, ii] is now commonly accepted in solid-state electrochemistry, chemistry, and physics, with adaptation to various specific cases [iii, iv].

According to this notation, the main symbol in a formula shows the species (usually elements) present in a certain site. The → vacancies are normally denoted by the italicized symbol V . Sometimes the vacant sites may also be indicated by other symbols, such as square box (\square), especially when the symbol of vanadium (V) is present. The right lower indexes may indicate the species occupying this crystallographic site in an ideal lattice, or may show that this position is interstitial (subscript i). The second right lower index, if any, indicates the occupancy and should be separated by a comma.

The → charge of the defect may be indicated by a right upper index. This index may show either the formal charge of an → ion (e.g., $n+$ or $n-$), or the effective charge with respect to the ideal structure. In the latter case, one unit of positive or negative effective charge is to be indicated by a superscript dot (\bullet) and prime ($'$), respectively. Zero effective charge with respect to the unperturbed lattice is explicitly indicated by a cross (\times). When the effective charge is higher than unity, the index can be written either analogously to the formal charge (e.g., superscript $n\bullet$) or using several symbols (e.g., $\bullet\bullet$ for double effective charge).

The free electrons and holes are denoted as e' and h^\bullet , respectively. The simplest defect clusters are usually written by listing all point defects between parentheses, with subsequent superscript showing the cluster effective charge. Note that parentheses and brackets are sometimes used also to indicate local coordination in the lattice.

Examples (Table 1):

Kröger-Vink notation — Table

Interstitial M^{2+} cation	M_i^\cdot
M^+ cation vacancy	V_M'
X^- anion occupying M^+ cation site	X_M''
Z^- anion occupying X^{2-} anion site	Z_X
A^{2+} cation at the M^{2+} site	A_M^x
A^{4+} cation at the M^{2+} site	$A_M^{x\cdot}$
Cluster formed by one X^{2-} vacancy and one A^{2+} cation occupying M^{3+} site	$(V_X^{\cdot\cdot} A_M^{\cdot})'$ or $(V_X A_M)'$

Refs.: [i] Kröger FA, Vink HJ (1956) *Solid State Phys* 3:307; [ii] Kröger FA (1964) *The chemistry of imperfect crystals*. North-Holland, Amsterdam; [iii] Conelly NG, Damhus T, Hartshorn RM, Hutton AT (eds) (2005) *Nomenclature for inorganic chemistry: IUPAC recommendations*. The Royal Society of Chemistry, London; [iv] <http://www.iupac.org/reports/provisional/abstract04/RB-prs310804/Chap11-3.04.pdf>

VK

Krüger cell — This was a variant of the → *Daniell cell*. See also → *zinc*, → Zn^{2+}/Zn electrodes, → $Zn^{2+}/Zn(Hg)$ electrodes, → *zinc-air batteries (cell)*, and → *Leclanché cell*.

Ref.: [i] Hauck WP (1883) *Die Galvanischen Batterien, Accumulatoren und Thermosäulen*, 2nd edn. Hartleben's Verlag, Wien

FS

Kublik, Zenon



(Jan. 6, 1922, Warsaw, Poland – Nov. 9, 2005, Warsaw, Poland) Kublik studied at Warsaw University, and there received his Ph.D. and habilitation degrees. From 1969 till his retirement in 1991 Kublik was Head of the La-

boratory of Polarography in the Department of Chemistry at Warsaw University. He is most famous for the construction of the → *hanging mercury drop electrode* (HMDE) which was a result of his Ph.D. work under supervision of → *Kemula*. Kublik published about 90 papers on voltammetric application of the HMDE, → *mercury film electrodes*, and → *amalgam electrodes*. He also served as Head of the Institute of Fundamental Problems of Chemistry in the Department of Chemistry, Warsaw University.

Ref.: [i] http://www.chem.uw.edu.pl/labs/ltae_add/history.htm

ZS

Kučera, Bohumil



(Courtesy of Petr Zuman, USA)

(Mar. 22, 1874 Semily, then Austro-Hungarian Empire – Apr. 16, 1921, Prague, Czechoslovakia) Since 1912, Professor of experimental physics at Charles University, Prague. Kučera introduced the measurement of surface tension of polarized mercury by applying the → *dropping mercury electrode* [i] rather than the → *Lippmann capillary electrometer*, and he inspired thereby → *Heyrovský, J.* to introduce → *polarography*.

Ref.: [i] Kučera G (1903) *Drud Ann Phys IV F 11:529, 698*

MHey

Küster, Friedrich Wilhelm



(© I. Wetzel, Berlin)

(Apr. 11, 1861, Falkenberg (Kr. Luckau), Germany – June 22, 1917, Frankfurt a. d. Oder, Germany) Küster stud-

ied sciences and mathematics in Berlin, Munich, and Marburg, where he received his Ph.D. for research in organic chemistry guided by Th. Zincke. In 1881 he received the habilitation for physical chemistry. In 1896 he moved to the University of Göttingen (on the initiative of → *Nernst*) and in 1897 to the University of Breslau. After 1899/1900 he was professor at the Bergakademie (mining college) Clausthal. In 1903 Küster published one of the first conductometric titrations (acid–base titration) [i]; however, there are good arguments that → *Kohlrausch*, → *Ostwald, F.W.*, and others performed conductometric titrations even earlier [iii]. The first potentiometric redox titration was published by his student → *Crotogino*.

Refs.: [i] *Stumpp E* (2005) *TU Contact (TU Clausthal) No. 16:31*; [ii] *Küster FW* (1903) *Z anorg Chem* 35; [iii] *Szabadváry E, Chalmers RA* (1983) *Talanta* 30:997

Kůta, Jaroslav



(July 30, 1924, Chrášťovice, then Czechoslovakia – Sep. 6, 1981 Prague, then Czechoslovakia, now Czech Republic) Kůta was a student and later co-worker of → *Heyrovský, J.* at the Polarographic Institute. Later he became assistant professor of physical chemistry at Charles University, Prague. He thoroughly studied various processes at the → *dropping mercury electrode*, and he is co-author of a textbook on polarography [i], translated into several languages.

Ref.: [i] *Heyrovský J, Kůta J* (1966) *Principles of polarography*. Academic Press, New York

MHey

L

Lagrange cell — Fabre de Lagrange developed a zinc-air → battery where the sulfuric acid dropped slowly through a column in which the carbon electrode was placed and down on to the zinc electrode. This was made to increase the current by a movement of the electrolyte solution, and thus decreasing the → concentration polarization. See also → Daniell cell, → zinc, → Zn^{2+}/Zn electrodes, → $Zn^{2+}/Zn(Hg)$ electrodes, → zinc-air batteries (cell), and → Leclanché cell.

Ref.: [i] Hauck WP (1883) *Die Galvanischen Batterien, Accumulatoren und Thermosäulen*, 2nd edn., Hartleben's Verlag, Wien

Laitinen, Herbert August



(Jan. 17, 1915, Otter Tail County, Minnesota, USA – Mar. 22, 1991) Of Finnish heritage, Laitinen studied chemistry at the University of Minnesota. His Ph.D. thesis, based on studies under the direction of → Kolthoff at the University of Minnesota, was entitled “A Quantitative Study of Diffusion by Electrolysis with Micro Electrodes”. With → Lingane, Herb Laitinen was one of Kolthoff’s disciples in bringing electrochemistry in America into the realm of Analytical Chemistry. His most productive years were during his professorship at the University of Illinois in Urbana, 1940–1974. Among his many accomplishments were pioneering studies of electrochemistry in two very demanding solvents: liquid ammonia and fused salts. A generation of students benefited from his tutelage and inspiration, among whom Robert → Osteryoung might be singled out. Following his retirement from the University of Illinois, Laitinen moved to Gainesville, where he continued with electrochemical research at the University of Florida until his death in 1991.

Lamb’s equation → quasielastic light scattering

Lambda probe — The so-called lambda probe (lambda sensor) is a potentiometric oxygen → gas sensor that is used to monitor the partial pressure of oxygen p_{O_2} (oxygen concentration), e.g., in the exhaust gas of cars in order to control the air/fuel ratio that is going to the internal combustion engine. The term “lambda” originates from the stoichiometry number λ which describes the composition of the air/fuel mixture, as follows:

$$\lambda = \frac{(m_{\text{air}}/m_{\text{fuel}})_{\text{real}}}{(m_{\text{air}}/m_{\text{fuel}})_{\text{stoich}}}$$

where m_{air} = mass of air, m_{fuel} = mass of fuel, subscript “real” indicates the actual air/fuel ratio, and subscript “stoich” indicates the stoichiometric air/fuel ratio (which depends on the exact composition of the fuel). When $\lambda < 1$ there is a fuel excess and when $\lambda > 1$ there is an excess of air. The Lambda probe gives a very steep voltage step at $\lambda = 1$ and can therefore be used to detect the stoichiometry point. To keep three-way catalysts for car exhaust gases working at their optimum a fast and precise feedback control is necessary that guarantees $\lambda = 1$.

The Lambda probe consists of a solid-state electrolyte (yttrium-stabilized zirconia) that is covered with porous platinum → electrodes on the inside (1) and outside (2) (see Fig.).

The Lambda probe is usually shaped like a sparking plug where the solid-state electrolyte forms a closed-end cylinder that it inserted into the exhaust gas. The inside of the cylinder is in contact with ambient air with a constant partial pressure of oxygen, $p_{O_2,1}$, and the outside is in contact with the exhaust gas in which the partial pressure of oxygen, $p_{O_2,2}$, is monitored by measuring the potential difference between the two platinum electrodes

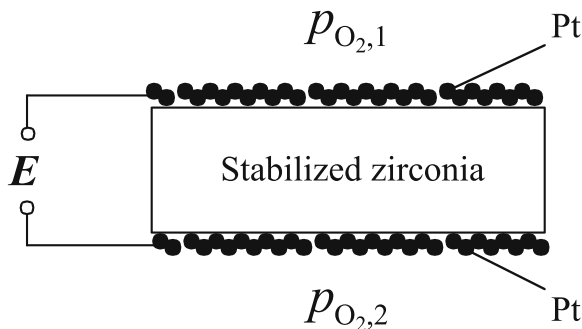

KBO **Lambda probe — Figure**

where the following two reactions take place:

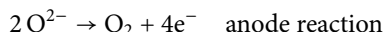
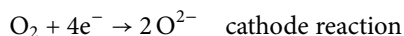

The O^{2-} ions are transported through the \rightarrow *solid electrolyte* (and also \rightarrow *stabilized zirconia*) at elevated temperature (above 400 °C). The measured potential of the sensor is then given by the \rightarrow *Nernst equation*:

$$E = E^\ominus + \frac{RT}{4F} \ln \left[\frac{p_{\text{O}_2,1}}{p_{\text{O}_2,2}} \right]$$

Ref.: [i] Göpel W, Hesse J, Zemel JN (1991) *Sensors – A comprehensive survey*, vols. 2 and 8. VCH, Weinheim

JB

Laminar flow — arises at low \rightarrow *Reynolds numbers* when $Re < Re_c$ and generally occurs when viscous forces dominate. It is characterized by the smooth steady flow of fluid in parallel layers or laminae, although each layer may not have the same velocity.

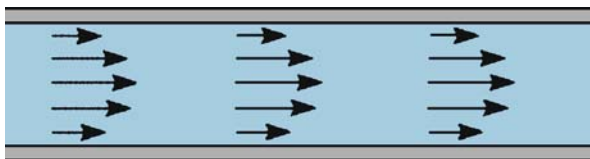

Laminar flow — **Figure.** Schematic of laminar flow through a pipe

The characteristics of laminar flow can allow mathematical prediction of the solution velocity and this has led to a range of hydrodynamic devices which use forced convection as a transport component under laminar flow conditions, examples include, the \rightarrow *rotating disk electrode* [i], \rightarrow *wall jet electrode* [ii], and channel flow cell (see \rightarrow *flow cell*).

Refs.: [i] Newman J (1966) *J Electrochem Soc* 113:501; [ii] Brett CMA, Oliveira Brett AM, Pereira JLC (1991) *Electroanalysis* 3:83

AF, SM

Laminar flow to turbulent flow transition — When increasing the velocity of the flow, a transition from \rightarrow *laminar flow* to “rippling” and finally to “turbulent” flow will occur [i]. The transition from laminar to turbulent flow is governed by the dimensionless \rightarrow *Reynolds number*.

Ref.: [i] Levich VG (1962) *Physicochemical hydrodynamics*. Prentice-Hall, Englewood Cliffs

FM

Landau free energy — Landau free energy is the free energy of the system F as a functional of an order parameter $\psi(\mathbf{r})$ characterizing the state of the system at fixed values of other thermodynamic parameters (temperature, pressure, etc.). Being first introduced for the description of second-order phase transitions, it was then used in the theory of superfluidity, superconductivity, ferromagnetism, etc., and is known also as Landau–Ginzburg free energy.

In chemistry it is used in particular in the theory of liquid state.

The order parameter $\psi(\mathbf{r})$ may be a scalar or vector field. An ordinary scalar variable ξ may play the role of an order parameter in some systems. Landau free energy represents in this case an ordinary function of ξ .

The minimum of Landau free energy functional with respect to the order parameter determines the equilibrium state of the system. The deviations of the order parameter from the equilibrium value describe equilibrium thermodynamic fluctuations.

Examples of the order parameter are the density of the liquid, $\rho(\mathbf{r})$, polarization vector of a dielectric medium, $\mathbf{P}(\mathbf{r})$, magnetic moment, $\mu(\mathbf{r})$, spin of the atom in the crystal lattice of a solid, S , and charge density in the electrolyte solution, $q(\mathbf{r})$.

The simplest form of the Landau free energy functional describing the state of the longitudinal polarization field $\mathbf{P}(\mathbf{r})$ in a homogeneous isotropic liquid in the presence of an external electric field $\mathbf{E}(\mathbf{r})$ is

$$F[\mathbf{P}(\mathbf{r})] = \frac{1}{2} \int d^3r \Phi(\mathbf{r} - \mathbf{r}') \mathbf{P}(\mathbf{r}) \mathbf{P}(\mathbf{r}') - \int d^3r \mathbf{P}(\mathbf{r}) \mathbf{E}(\mathbf{r})$$

where the function $\Phi(\mathbf{r} - \mathbf{r}')$ characterizes the spatial correlation properties of the polarization in the liquid. In the absence of spatial correlations $\Phi(\mathbf{r} - \mathbf{r}') = [4\pi/(1 - 1/\epsilon)] \delta(\mathbf{r} - \mathbf{r}')$ where $\delta(\mathbf{r} - \mathbf{r}')$ is the Dirac δ -function and ϵ the dielectric constant (permittivity) of the liquid. In general the Fourier components of $\Phi(\mathbf{r} - \mathbf{r}')$ depend on the wave vector \mathbf{k} .

At small \mathbf{k} (long-wave approximation) in a one-mode pole approximation this dependence has the form $\Phi(\mathbf{k}) = [4\pi/(1 - 1/\epsilon)] (1 + \lambda k^2)$ where λ is the correlation length. This form corresponds to a gradient expansion of the Landau free energy functional

$$F[\mathbf{P}(\mathbf{r})] = \frac{2\pi}{1 - 1/\epsilon} \int d^3r \left\{ [\mathbf{P}(\mathbf{r})]^2 + \lambda^2 |\nabla \mathbf{P}(\mathbf{r})|^2 \right\} - \int d^3r \mathbf{P}(\mathbf{r}) \mathbf{E}(\mathbf{r}) .$$

The functionals of this type allow calculating the equilibrium value of the polarization and free energy of the system, spatial correlation function of the polarization, contribution of the solvent reorganization to the activation free energy of charge transfer processes in polar media, etc.

Refs.: [i] Landau LD, Lifshitz EM (1970) *Statistical physics*, 2nd edn. Pergamon, Oxford; [ii] Kuznetsov AM (1997) *Stochastic and dynamic views of chemical reaction kinetics in solutions*. Presses polytechniques et universitaire romandes, Lausanne; [iii] Kornyshev AA, Leikin S, Sutmacher G (1997) *Electrochim Acta* 42:849

AMK

Lange, Erich



(Reproduced from [iv])

(Nov. 26, 1896, Hartha near Waldheim, Germany – Apr. 24, 1981) Lange started his chemistry studies at the Technical University of Dresden, where at that time → Foerster worked as electrochemist. Following his diploma examinations he moved to the University of Munich where he worked with Kasimir Fajans on electrochemical problems, including problems associated with the → Debye–Hückel theory. Already at that time he performed extremely precise calorimetric measurements of dilution heats of → electrolyte solutions. He obtained his Ph.D. in 1924, and in 1928 he habilitated with calorimetric measurements testing the Debye–Hückel theory. In 1932 he was appointed as Professor at the University of Erlangen, where he continued his thermodynamic studies of electrochemical systems. Since 1959 he was full Professor at Erlangen University [i]. Lange has made a lasting contribution to electrochemistry by publishing very clear and precise texts on electrochemical thermodynamics [ii, iii].

See also → potential, and the subentry → inner electric (or internal electric) potential.

Refs.: [i] Obituary: Schwabe K (1979–1980) *Jahrbuch der Sächsischen Akademie der Wissenschaften*, 235–236; [ii] Lange E, Koenig FO (1933) *Elektrochemie der Phasengrenze*. In: Wien W, Harms F, Fajans K, Schwartz E (eds) *Elektrochemie. Handbuch der Experimentalphysik*, vol.

12, part 2. Akadem Verlagsges, Leipzig; [iii] Lange E, Göhr H (1962) *Thermodynamische Elektrochemie*. Hüthig, Heidelberg; [iv] Gerischer H (1971) *Z Elektrochem (Ber Bunsenges)* 75:1153

FS

Langmuir, Irving



(© The Nobel Foundation)

(Jan. 31, 1881, Brooklyn, New York, USA – Aug. 16, 1957, Woods Hole, Massachusetts, USA) Langmuir graduated as a metallurgical engineer from the School of Mines at Columbia University in 1903. He received his Ph.D. in 1906 from the University of Göttingen (Germany) for work performed under the guidance of → Nernst. After his return to the US Langmuir joined the Stevens Institute of Technology (Hoboken, NJ) and in 1909 he entered the Research Laboratory of the General Electric Company, Schenectady. Langmuir studied intensively adsorption esp. from gases under vacuum conditions, the nature of electric discharge in vacuum and gases under low pressures (see → Langmuir adsorption isotherm, → adsorption isotherm) [i]. He was the first to observe stable monoatomic adsorbate films of hydrogen on W and Pt filaments. Langmuir discovered that small partial pressures of nitrogen slow down the evaporation of tungsten from filaments in vacuum bulbs, and he also discovered that coiled filaments are superior to non-coiled. In 1924 he invented a method to measure both the temperature and density of a plasma with the help of an electrostatic probe that is now called Langmuir probe. He studied the behavior of films on water surfaces, and for the measurement of → surface pressure he constructed a surface film balance (Langmuir-balance) [ii] which was a technical improvement of the device used by → Pockels. Together with → Blodgett he worked on monolayers, a work resulting in what is now called → Langmuir–Blodgett films. In 1932 he was awarded the Nobel Prize in Chemistry. During WW II he performed research on developing protective smoke and a method for the de-icing of airplane wings. This research led him also to develop a technique to induce

rain, the so-called seeding of clouds, with the help of, e.g., silver iodide crystals. His collected works have been published [iii].

Refs.: [i] *Langmuir I* (1916) *J Am Chem Soc* 38:2221; [ii] *Langmuir I* (1917) *J Am Chem Soc* 39:1845; [iii] *Suits CG (gen ed) Way HE (exec ed) Langmuir, Irving (1960-1962) The collected works of Irving Langmuir with contributions in memoriam, including a complete bibliography of his works, 12 vols. Pergamon Press, New York*

Langmuir adsorption isotherm → *Langmuir* [i, ii] proposed the adsorption isotherm

$$k = \frac{\alpha^s}{p\alpha_0^s} = \frac{\Theta}{p\Theta_0} \quad (1)$$

k is a constant which is the ratio of the rates of the adsorption and desorption processes, p is the → *partial pressure* of the adsorbable compound in the gas phase (or the pressure of a gas in vacuum, or it can be the → *concentration* in a solution), α_0^s is the surface concentration of free active sites on the adsorbent,

$$\Theta_0 = \frac{\alpha_0^s}{\alpha_m^s} \quad (2)$$

is the fraction of the surface covered with free active sites, α_m^s is the maximum surface concentration for a unimolecular adsorbed film, and α^s is the surface concentration of occupied sites on the surface, i.e., the surface concentration of the adsorbate. Taking into account that

$$\alpha^s + \alpha_0^s = \alpha_m^s, \quad (3)$$

rearrangement of Eqs. (1) and (2) gives:

$$k = \frac{\alpha^s}{p(\alpha_m^s - \alpha^s)} = \frac{\Theta}{p(1 - \Theta)} \quad (4)$$

and finally

$$\Theta = \frac{kp}{1 + kp}. \quad (5)$$

Instead of c , for adsorption from the gas phase, it is custom to use the partial pressure. For that isotherm it has to be assumed (a) that a localized adsorption (i.e., finite and defined number of adsorption sites) takes place at an isotropic surface, (b) that the adsorbed particles do not interact with each other, and (c) that the maximum coverage is a monolayer of the adsorbed particles [iii]. About the importance of the Langmuir isotherm in electrochemistry see → *adsorption isotherm*.

Refs.: [i] *Langmuir I* (1916) *J Am Chem Soc* 38:2221; [ii] *Langmuir I* (1918) *J Am Chem Soc* 40:136; [iii] *Ościak J (1982) Adsorption. PWN, Warsaw, Ellis Horwood, Chichester*

FS

Langmuir–Blodgett films — are films that are produced on a solid substrate by a technique developed by → *Langmuir* and → *Blodgett*. The respective monolayers of organic compounds are transferred from the liquid|air interface onto a solid support by immersing (or emersing) the solid substrate into (or from) the liquid. A monolayer is added with each immersion or emersion step, thus films with very accurate thickness can be formed. In a first step, an → *amphiphilic compound* is dissolved in an organic solvent and subsequently spreads on the liquid|air interface. The solvent evaporates and a so-called Langmuir monolayer appears. By gentle compression, these moieties are ideally arranged into one molecular layer, using a moveable barrier, to control the area per molecule. The monolayers serve as building block for the fabrication of thin layers by transferring them onto a solid support. That is, a solid target is dipped into the water and refused, thus forming the monolayer on the target. Onto hydrophilic surfaces, this is done by an up-stroke, while onto a hydrophobic surface – via a down-stroke. This usually automated procedure can be repeated, even with several layers of, if desired, differing properties, to achieve the desired layer sequence. The transfer ratio is defined as the ratio of the decrease in Langmuir monolayer surface area divided by the area of the covered solid support; a transfer ratio of one is achieved. Conventional applications of L.B. films include gas sensor devices, often combined with a → *quartz crystal microbalance*, or, with higher sensitivity, combined with optical reflectance techniques as → *ellipsometry* or surface plasmon spectroscopy, SPS (see also → *plasmon resonance*). Many of the latter utilize the properties of phthalocyanine compounds. Several organic moieties, processed via L.B. technique, comprise nonlinear optical (NLO) second-order effects, with respective applications as NLO materials and devices, i.e., for generation of new frequencies (frequency doubling, sum frequency generation), and modulation of light by an external electric or magnetic field. L.B. materials possess inherent potential as molecular rectifier giving access to electronic molecular memory devices, or for designing “command surfaces”, i.e., a single L.B. monolayer with the respective functionalized molecules can be addressed to control the properties and order in the adjacent bulk phase. Novel types of L.B. films are obtained by the organization of metallic nanoparticles at the air–

water interface and the following application of the outlined L.B. technique. The respective films provide the possibilities of an ordered array of metal quantum dots.

See also → *self-assembled monolayers* as an alternative technique of creating monolayers.

Refs.: [i] Ulmann A (1991) *An introduction to ultrathin organic films: from Langmuir–Blodgett to self-assembly*. Academic Press, San Diego; [ii] Roberts G (1990) *Langmuir–Blodgett films*. Plenum Press, New York; [iii] Peterson IR (2000) *Langmuir monolayers*. In: Richardson TH (ed) *Functional organic and polymeric materials*. Wiley, New York; [iv] Hähner G (2001) *Organic films (Langmuir–Blodgett films and self-assembled monolayers)*. In: Moore, JH, Spencer ND (eds) *Encyclopedia of chemical physics and physical chemistry*. Taylor & Francis Boca Raton, pp 2608–2620; [v] Frederikse HPR (2003) *Nonlinear optical constants*. In: Lide DR (ed) *CRC handbook of chemistry and physics*, 84th edn., 2003–2004. CRC Press Boca Raton, pp 12-168–12-171

MHer

Langmuir–Hinshelwood kinetics → *adsorption kinetics*

Laplace transformation — One of a family of mathematical operations called “integral transforms”, Laplace transformation converts a function $f(t)$, usually of time, into another function $\tilde{f}(s)$ of a “dummy” variable s . The definite integral $\int_0^{\infty} f(t) \exp(-st) dt = \tilde{f}(s)$ defines the “image function” $\tilde{f}(s)$. The motive for transforming in this way is that operations of the calculus, such as the solution of differential equations, are more easily performed “in Laplace space”. For example, integration with respect to t is equivalent to division by s .

In electrochemistry, the most frequent use of Laplace transformation is in solving problems involving → *diffusion* to an electrode. → *Fick’s second law*, a partial differential equation, becomes an ordinary differential equation on Laplace transformation and may thereby be solved more easily.

Refs.: [i] Boas ML (1983) *Mathematical methods in the physical sciences*, 2nd edn. Wiley, New York; [ii] Bard AJ, Faulkner LR (2001) *Electrochemical methods*, 2nd edn. Wiley, New York; [iii] Oldham KB, Myland JC (1994) *Fundamentals of electrochemical science*. Academic Press, San Diego

KBO

Lattice-gas model — This is a variant of the → *Ising model*, in which the component of the spin is interpreted as the presence or absence of certain particles. In electrochemistry, this model has been applied to → *adsorption* phenomena and to liquid–liquid interfaces.

WS

LB films → *Langmuir–Blodgett films*

Lead–acid accumulator — secondary (electrically rechargeable) battery employing a lead and a lead dioxide electrode; see → *accumulator*.

RH

Lead–acid battery → *lead–acid accumulator*

Le Blanc, Max Julius Louis



(May 26, 1865, Barten, East Prussia, Germany, now Barciany, Poland – July 31, 1943, Leipzig, Germany) German scientist who studied at the universities of Tübingen, Munich, and Berlin, became professor of Physical Chemistry at Leipzig University, and subsequently he was head of the electrochemistry division of Hoechst Farbenwerke. Afterwards he served as chair of physical chemistry at the Technical Institute in Karlsruhe, finally in 1906 he returned to Leipzig University as director of the Institute of Physical Chemistry. He supervised most of the construction works at the latter two institutes. Author of highly successful textbooks on electrochemistry including “The Elements of Electrochemistry” (1896) and “A Textbook of Electrochemistry” (1907). Studies of electrochemical polarization dominated his work. This includes the decomposition voltage of aqueous solutions and the understanding of electrode processes. Using a third (independent) → *reference electrode* he could determine anode and cathode electrode potentials in the electrolytic cell during → *electrolysis* separately. He introduced the → *hydrogen electrode* [i].

Ref.: [i] Le Blanc M (1893) *Z physik Chem* 12:333

RH

Leclanché, Georges

(Oct. 9, 1839, Parmain, France – Sep. 14, 1882, Paris, France) French chemist, engineer by training, developed a dry battery (→ *Leclanché cell*).

Refs.: [i] Magnusson M (ed) (1990) *Chambers biographical dictionary*. W&R Chambers, Edinburgh; [ii] Crystal D (ed) (1998) *The Cambridge biographical encyclopedia*. Cambridge University Press, Cambridge

RH

Leclanché cell — Primary cell (→ *Leclanché*; 1866) containing a manganese dioxide cathode in an aqueous electrolyte solution of NH_4Cl (20 wt %) in a zinc beaker used as anode (negative electrode, negative mass). Gelatin is added to enhance the viscosity of the electrolyte solution. Electrode reactions are

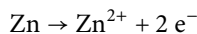

and

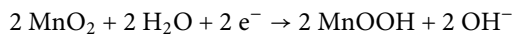

whereas in the electrolyte solution

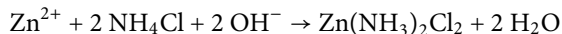

The resulting cell reaction is

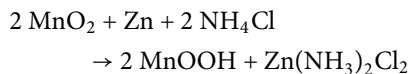

The actual cell voltage is about 1.5 V, it does not depend on the actual pH-value of the electrolyte solution as obvious from the absence of protons and hydroxide ions in the cell reaction equation. It slightly depends on the source of the used manganese dioxide. Initially naturally occurring manganese dioxide was used. The battery required a quality of less than 0.5% copper, nickel, cobalt, and arsenic to avoid undue corrosion of the zinc electrode. Currently synthetic manganese dioxide is prepared either by chemical (CMD) or electrochemical (EMD) procedures. For improved electrical conductivity graphite or acetylene black are added. Upon deep

discharge the cell reaction changes to:

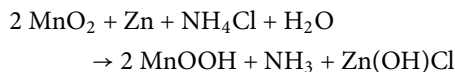

Hydrogen developed during corrosion of the zinc electrode can cause internal overpressure resulting in leakage of electrolyte solution. The same effect can result from the release of lattice water from the manganese oxide upon reduction. Partial or complete replacement of NH_4Cl by ZnCl_2 results in a water-consuming reaction alleviating the latter problem:

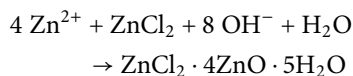

Corrosion of zinc was initially prevented by amalgamation of the zinc electrode (i.e., by adding soluble mercury salts which result in a mercury deposit by → *cementation*). Currently organic additives are used for corrosion prevention.

Ref.: [i] Linden D, Reddy TB (eds) (2002) *Handbook of batteries*. McGraw-Hill, New York

RH

Letheby, Henry (1816–1876) — Letheby was a professor of chemistry and toxicology at the Medical College of London Hospital. He worked as Medical Officer of Health of the City of London [i]. He was engaged in the study of poisons and food adulteration, his reports on the bad hygienic conditions in London aroused Karl Marx's interest who cited those in the Capital. He was also a member of the London Electrical Society. While working with aniline in 1862, he discovered that during electrolysis a material was deposited on the electrode which changed color upon oxidation and reduction [ii]. It was the first report on the material which now is called → *polyaniline*. For this reason he became a highly cited author also in the field of electrochemistry, recently [iii].

Refs.: [i] *Obituary, Lancet* 1876, I, 509; [ii] *Letheby H (1862) J Chem Soc* 15:161; [iii] <http://chemweb.com>

GI

Leucoemeraldine → *polyaniline*

Leveling agent (leveler) — Leveling agents are used as additives in → *electroplating baths* to reduce the surface roughness of a substrate during the deposition of a layer. Leveling is important in the electronics industry (uniform deposition in microprofiles) and for the → *electroforming* of micromechanical devices. Even in the absence of leveling agents grooves in the substrate will pro-

gressively disappear provided that the current distribution is uniform (geometric leveling). Geometric leveling occurs for deposition thickness at least equal to the depth of the groove. Leveling in the presence of leveling agents (true or electrochemical leveling) is achieved much earlier. In the case of nickel electroforming, 2-butynyl 1,4-diol can act as a leveling agent. Important parameters in the mechanisms of leveling are the preferential adsorption of the leveling agent and the effect on polarization.

Ref.: [i] Paunovic M, Schlesinger M (2006) *Fundamentals of electrochemical deposition*. Wiley, New York, pp 190–193

Levich, Veniamin (Benjamin) Grigorievich

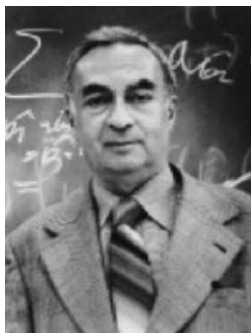

(Courtesy of Benjamin Levich Institute for Physico-Chemical Hydrodynamics)

(Mar. 30, 1917, Kharkov, Russia, now Kharkiv, Ukraine – Jan. 19, 1987, Englewood, New Jersey, USA) Levich was a leading scientist in the field of electrochemical hydrodynamics, which he was the first to establish as a separate scientific discipline [i, ii]. He is best known for the development of the → *rotating-disk electrode* as a tool for electrochemical research. The famous → *Levich equation* describing a current at a rotating-disk electrode is named after him. His fundamental contributions to theoretical physics and physical chemistry have been recognized worldwide after the publication of the English translation of his monograph “Physicochemical Hydrodynamics” in 1962 [iii]. His research activities also included gas-phase collision reactions and the quantum mechanics of electron transfer. Levich was one of the first Soviet scientists who succeeded to emigrate from the USSR in 1978, first to Israel and then to the USA. A strong international campaign in his support helped him to leave the Soviet Union that was closed for immigration at that time. Upon his arrival in Israel, Levich received offers from many universities. In 1979, he finally accepted the invitation to become the Albert Einstein Professor of Science at the City College of New York, where he established the Institute of Applied Chemical

Physics that is named now Benjamin Levich Institute for Physico-Chemical Hydrodynamics.

Refs.: [i] Bockris JO'M, Reddy AKN, Gamboa-Aldeco M (2000) *Modern electrochemistry, fundamentals of electrochemistry*, vol. 2A, 2nd edn. Kluwer, New York, p 1140; [ii] Acrivos A (1992) *Memorial tributes: National Academy of Engineering*, vol. 5. The National Academies Press, Washington DC, pp 165–170; [iii] Levich VG (1962) *Physicochemical hydrodynamics*. Prentice-Hall, Englewood Cliffs, (the first Russian edition was published in 1952)

EK

Levich equation — The diffusion-limited (i.e., transport-controlled) current at a → *rotating-disk electrode* is given by the Levich equation:

$$I_{\text{lim,diff}} = 0.62nFAD^{2/3}\omega^{1/2}\nu^{-1/6}c^*$$

with the electrode surface area A , the → *angular velocity* ω , the kinematic → *viscosity* ν , the concentration c^* , the number of electrons transferred in the electrode reaction n , the → *diffusion coefficient* D , and the → *Faraday constant* F .

Refs.: [i] Bard AJ, Faulkner LR (2001) *Electrochemical methods*, 2nd edn. Wiley, New York; [ii] Levich VG (1962) *Physicochemical hydrodynamics*. Prentice-Hall, Englewood Cliffs

RH

Levich plot → *Koutecky-Levich plot*

Lewis, Gilbert Newton

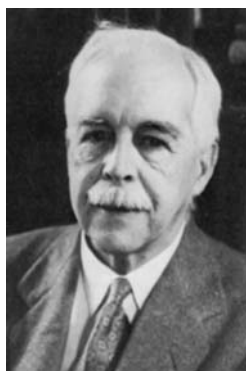

Reproduced from [i] with permission of the Welch Foundation

(Oct. 23, 1875, Weymouth, Mass., USA – Mar. 23, 1946, Berkeley, USA) Lewis studied at Harvard University where he got the B.A in 1896 and his Ph.D. in 1899. After the Ph.D. he worked in the laboratory of → *Ostwald*, F.W. in Leipzig, and in the laboratory of → *Nernst* in Göttingen, Germany. He returned to Harvard as an instructor and in 1904 went to Manila as superintendent of weights and measures for the Bureau of Science of the

Philippine Islands. In 1905 he was appointed a faculty position at MIT, Cambridge, USA, where he worked under Arthur Amos Noyes. In 1907 Lewis became assistant professor, in 1908 associate professor, and in 1911 full professor at MIT. Since 1912 he was professor of physical chemistry at the University of California, Berkeley, where he died at the age of 70 of a heart attack while working in the laboratory. Lewis made important contributions to physics and physical chemistry. He worked on the theory of relativity, and in 1916 he published the idea of a covalent bond resulting from paired electrons. In 1923, the same year when \rightarrow Brønsted and \rightarrow Lowry published their \rightarrow acid–base theories, Lewis published what is now known as the Lewis acid–base theory (electron-pair donor-acceptor interaction). Lewis made fundamental contributions to chemical thermodynamics, esp. by determining the \rightarrow free energy changes of chemical reactions, and he introduced the concept of \rightarrow fugacity, \rightarrow activity, \rightarrow activity coefficients, as well as the concept of \rightarrow ionic strength of a solution. Lewis was the first to produce a pure sample of heavy water in 1933. He studied the properties of atomic nuclei at the Ernest O. Lawrence cyclotron, and in his final years he discovered that phosphorescence of organic molecules is based on excited triplet states.

Refs.: [i] Calvin M (1976) *Proc The Robert A. Welch Found Conf on Chem Res, XXth American Chemistry – Bicentennial* (Nov 8-10, 1976, Houston, Texas) 116-150; Calvin M (1984) *J Chem Educ* 61:14; [ii] Laidler K (1993) *The world of physical chemistry*. Oxford University Press, Oxford, pp 30, 126, 218, 320, 341, 437; Lewis GN (1901) *Z phys Chem* 38:205; Lewis GN (1901) *Proc Am Acad* 37:49; Lewis GN (1908) *Z phys Chem* 61:129; Lewis GN (1908) *Proc Am Acad* 43 : 259

FS

Lewis acid–base theory \rightarrow acid–base theory

Lewis-Surgent equation \rightarrow potential, \rightarrow diffusion potential

Leyden jar — was a device developed in the 18th century and used by early experimenters to store electric energy and to conduct many early experiments in electricity [i, ii]. This device revolutionized early experiments with static electricity allowing accumulation of large amounts of charges. The device was also called a "condenser" because many people thought of electricity as fluid or matter that could be condensed. According to the modern terminology it is a capacitor. The device was a glass jar coated inside and outside with metal separated by glass. The metal electrodes can accumulate opposite charges, thus storing a big amount of electric charge. Leyden

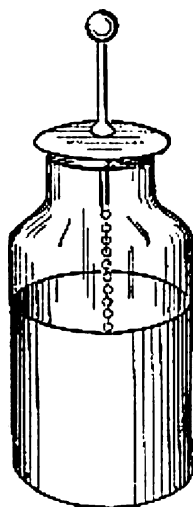

Leyden jar — Figure

jars were invented in 1745 by Pieter van Musschenbroek, a physicist and mathematician in Leyden, the Netherlands. It should be noted that the same device was independently invented by Ewald Georg von Kleist, a German cleric, but he did not investigate it as thoroughly as did Musschenbroek. The name "Leyden jar" was given to the device by \rightarrow Nollet who extensively studied its application for numerous electrical experiments.

Refs.: [i] Heilbron JL (1979) *Electricity in the 17th & 18th centuries: A study in early modern physics*. University of California Press, Berkeley; [ii] Dorsman C, Crommelin CA (1957) *The invention of the Leyden jar*. National Museum of the History of Science, Leiden

EK

LFER \rightarrow linear free energy relationship

Liesegang, Raphael Eduard



(Courtesy of Klaus Beneke, Kiel)

(Nov. 1, 1869, Elberfeld, Germany – Nov. 13, 1947, Bad Homburg, Germany) Liesegang first attended a college of photography, then the Fresenius Institute of Analytical Chemistry, Wiesbaden, before he studied chemistry

at the University of Freiburg im Breisgau. He left the university in 1892 without the final examination. That year he started in the photographic company of his father. In 1904 he sold the photo-paper production to Bayer, Leverkusen, and his brother continued the optical department of the company. Liesegang continued his scientific work as a private scientist. Since 1909 he worked for the Senckenberg Museum in Frankfurt/M. and soon after in the Neurological Institute of the Surgical Clinic of the University Hospital in Frankfurt. He became Dr. phil. h.c. (honorary doctor) in Gießen, and Dr. med. h. c. in Frankfurt [i]. Liesegang invented the photographic hydroquinone developer “Aristogen”, contributed to various parts of colloid science, and he is best remembered for the discovery of the so-called Liesegang rings, patterns that build in the course of chemical reactions in gels [ii–v]. These reaction patterns are akin to the \rightarrow *electrochemical oscillations* as they are dissipative structures.

Refs.: [i] (1985) *Neue Deutsche Biographie*, vol. 14. Duncker & Humblot, Berlin; [ii] Liesegang RE (1896) *Naturwiss Wochenschrift* 11:353; [iii] Liesegang RE (1907) *Z phys Chem* 59:444; [iv] Liesegang RE (1943) *Kolloide in der Technik*, 2nd edn. T Steinkopf, Dresden; [v] Freundlich H (1932) *Kapillarchemie*, vol. II. Akademische Verlagsgesellschaft, Leipzig, pp 701

FS

Lifshitz constants \rightarrow *Hamaker constant*

LIGA technology — An acronym from German words for lithography (Lithographie), electroplating (Galvanoformung), and molding (Abformung). The process consists of sputtering, lithography, \rightarrow *etching*, \rightarrow *electroforming*, aligned bonding, forming, surface micro machining, bulk micro machining, and micro assembling. LIGA technology can fabricate 3-D metal microstructures. The feature definition, radius, and side-wall texture using LIGA are superior to current precision machining techniques. LIGA is applied in informatics, electronics, biomedicine, optoelectronics, and communication.

Ref.: [1] Menz W, Mohr J, Paul O (2001) *Microsystem technology*. Wiley-VCH, Weinheim

MD

Ligand — An electron-pair donor species, commonly an anion or a neutral molecule that can form one or several bonds, involving highly covalent character, with metal species. A ligand with a single donor group is usually called unidentate, whereas the terms bidentate, tridentate, tetradentate, pentadentate, and hexadentate are commonly used to indicate the number of bonds that

a ligand with several pairs of unshared electrons can form in a \rightarrow *chelate* [i].

In biochemistry, this term is also employed to denominate the atoms, groups, or molecules bound to a central polyatomic molecular entity. Thus, the biochemical usage of this term is wider, since it not only can be assigned to a hormone that is binding to a receptor, but also to ions like H^+ that may be considered as ligands for proteins [ii].

Refs.: [i] Cotton FA, Wilkinson G, Murillo CA, Bochmann M (1999) *Advanced inorganic chemistry*. Wiley Interscience, New York; [ii] IUPAC (1997) *Compendium of Chemical Terminology*

FG

Ligand-gated ion channel \rightarrow *ion transport through membranes and ion channels*

Lilienfeld, Julius Edgar — (Apr. 18, 1881, Lemberg, Austro-Hungarian Empire, now Lviv, Ukraine – Aug. 28, 1963, Charlotte Amalie, the Virgin Islands, USA) Lilienfeld proposed the basic principle behind the MOS field-effect transistor in 1925 [i]. This was the background of all field-effect transistors used now, including \rightarrow *ion-selective field-effect transistors* (ISFETs) used in numerous electrochemical sensors.

Refs.: [i] Kleint C (1998) *Prog Surf Sci* 57:253

EK

Limit of detection — The limit of detection (LOD) is the lowest concentration of an \rightarrow *analyte* that can be detected by an analytical method with a chosen statistical probability. LOD is derived from the smallest response that can be detected with reasonable certainty (R_{LOD}) and the sensitivity (S) of the method. The value R_{LOD} is given by the equation: $R_{LOD} = \overline{R}_{bg} + ks_{bg}$, where \overline{R}_{bg} is the mean of the background measures, s_{bg} is the standard deviation of the background measures and k is a numerical factor chosen according to the confidence level desired [i]. If $k = 3$ this definition corresponds to a 99.865% probability that the background measure does not exceed the LOD value [ii]. The sensitivity is defined as the ratio of the net response of the \rightarrow *detector* and the concentration of the analyte: $S = \Delta R/c$. The net response is the difference between the response and the background measure: $\Delta R = R - R_{bg}$. So, the limit of detection in concentration units is given by: $c_{LOD} = ks_{bg}/S$ [iii].

Refs.: [i] McNaught AD, Wilkinson A (1997) *IUPAC compendium of chemical terminology*, 2nd edn. Blackwell Science, Oxford; [ii] Mocak J, Bond AM, Mitchell S, Scollary G (1997) *Pure Appl Chem* 69:297; [iii] Toth K, Štulík K, Kutner W, Feher Z, Lindner E (2004) *Pure Appl Chem* 76:1119

ŠKL

Limit of quantitation — (LOQ) The lowest amount of \rightarrow *analyte* in a \rightarrow *sample* that can be quantitatively determined [i]. The LOQ is related to a signal value (y_Q) at which the \rightarrow *analyte* can surely be detected. It is defined by the following equation: $y_Q = \mu_b + k_Q \sigma_b$, μ_b and σ_b are the population \rightarrow *mean* and the \rightarrow *standard deviation* of the blank signal. The use of $k_Q = 9$ is recommended in order to have only a 0.135% of risk that a single signal measured in quantitative analysis is below the limit where it can be surely detected [ii].

Refs.: [i] Harris D (2002) *Quantitative chemical analysis*. WH Freeman, New York; [ii] Mocak J, Bond AM, Mitchell S, Scollary G (1997) *Pure Appl Chem* 69:297

FG

Limiting current — Limiting – potential-independent – current is achieved when the electrode process is occurring at the maximum rate possible for a given set of mass transfer conditions (\rightarrow *electrode potential*, concentration, stirring rate, electrode area, cell geometry, temperature, composition of the solution, ...) It is the case in a well-stirred solution at usual electrodes, or when a \rightarrow *rotating-disk electrode*, a \rightarrow *dropping mercury electrode*, or a \rightarrow *microelectrode* is applied at a relatively high \rightarrow *overpotential*. The applied potential is usually at least 120 mV (in absolute value) higher than the \rightarrow *equilibrium* \rightarrow *redox* or \rightarrow *half-wave potential*. Under these conditions the current reaches a constant (steady-state) value, which is limited only by \rightarrow *mass transport* or the rate of the chemical reaction preceding the charge transfer step. See also \rightarrow *current*, \rightarrow *diffusion*, \rightarrow *diffusion-controlled rate*, \rightarrow *diffusion overpotential*, \rightarrow *polarography*, \rightarrow *reaction overpotential*.

JL

Limiting current titration \rightarrow *amperometric titration*

Linear free energy relationship (LFER) — For various series of similar chemical reactions it has been empirically found that linear relationships hold between the series of free energies (\rightarrow *Gibbs energy*) of activation ΔG_i^\ddagger and the series of the standard free energies of reactions ΔG_i^\ominus , i.e., between the series of $\log k_i$ (k_i – rate constants) and $\log K_i$ (K_i – equilibrium constants) (i labels the compounds of a series). Such relations correlate the \rightarrow *kinetics* and \rightarrow *thermodynamics* of these reactions, and thus they are of fundamental importance. The LFER's can be formulated with the so-called Leffler-Grunwald operator δ_R :

$$\delta_R \Delta G_{i,j}^\ddagger = a_j \delta_R \Delta G_{i,j}^\ominus, \quad (1)$$

and

$$\delta_R \Delta G_{i,j}^\ddagger = b_{j,j+1} \delta_R \Delta G_{i,j+1}^\ddagger = a_{j+1} b_{j,j+1} \delta_R \Delta G_{i,j+1}^\ominus, \quad (2)$$

where a and b are constants, i labels the compounds of a series, and j labels the reactions [i]. The existence of LFER's also implies (a) linear correlations between the free energies of activation $\Delta G_{i,j}^\ddagger$ and $\Delta G_{i,j+1}^\ddagger$ for series of similar compounds i in two reactions labeled j and $(j+1)$, and (b) of the standard free energies of reactions $\Delta G_{i,j}^\ominus$ and $\Delta G_{i,j+1}^\ominus$ of similar compounds i in two reactions labeled j and $(j+1)$. Several LFER's are known under specific names, e.g., the \rightarrow *Brønsted relation* correlating the logarithms of rate constants of ester hydrolysis with the \rightarrow *acidity constants* of the acids, the \rightarrow *Hammett equation* relating the \rightarrow *rate constants* and \rightarrow *equilibrium constants* of series of substituted benzene derivatives with the help of characteristic substituent constants, and many other LFER's used especially in organic chemistry. LFER's have been observed in electrochemistry [e.g., ii], and \rightarrow *Frumkin's slow discharge theory* has been inspired by the Brønsted relation. See also \rightarrow *Marcus theory*, and \rightarrow *Polanyi's rule*. For the case of homogeneous reversible and irreversible electron transfer reactions it has been shown that LFER's are special cases of more general nonlinear relationships [iii]. See also \rightarrow *Hammett equation (or Hammett relation)*.

Refs.: [i] Hammett LP (1970) *Physical organic chemistry*. McGraw-Hill, New York; [ii] D'Souza F, Zandler ME, Tagliatesta P, Ou Zh, Shao J, Van Caemelbecke E, Kadish KM (1998) *Inorg Chem* 37:4567; [iii] Scandola E, Balzani V, Schuster GB (1981) *J Am Chem Soc* 103:2519

FS

Linear scan voltammetry (LSV) — It is an experimental method when the \rightarrow *electrode potential* is varied linearly with time (t) with a scan (sweep) rate $v = dE/dt$ and the current (I) vs. E curve (which is equivalent with E vs. t curve) is recorded. Usually scan rates ranging from 1 mV s^{-1} to 1 V s^{-1} are applied in the case of conventional electrodes with surface area between 0.1 and 2 cm^2 , however, at \rightarrow *ultramicroelectrodes* 1000 or even 10^6 V s^{-1} can also be used. The scan is started at a potential where no electrochemical reaction occurs. At the potential where the charge transfer begins, a current can be observed which increases with the potential, however, after a maximum value (current peak) it starts to decrease due to the depletion of the reacting species at the \rightarrow *interface*.

In LSV essentially only the first half-cycle of a cyclic voltammogram (\rightarrow *cyclic voltammetry*) is executed.

Ref.: [i] Bard AJ, Faulkner LR (2001) *Electrochemical methods*. Wiley, New York, p 236

AMB

Linear sweep voltammetry \rightarrow *linear scan voltammetry*

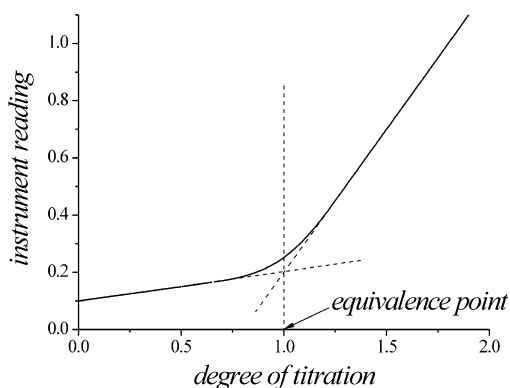

Linear titration curve — Figure

Linear titration curve — A type of \rightarrow *titration curve* in which a variable that is directly proportional to the concentration of the \rightarrow *titrand* and/or \rightarrow *titrant*, and/or a product of their chemical reaction is plotted as a function of the volume of titrant added. Thus, a linear titration curve generally consists of two linear segments that have to be extrapolated to intersect at a point that is associated with the \rightarrow *equivalence point*. The measurements are performed below and above the zone of the equivalence point and preferably away from this last point where nonlinear behavior is commonly found [i]. Linear titration curves are typical for \rightarrow *amperometric titrations*, and \rightarrow *conductometric titrations*, whereas \rightarrow *potentiometric titrations* yield nonlinear curves (\rightarrow *logarithmic titration curve*).

Ref.: [i] Harris D (2002) *Quantitative chemical analysis*. WH Freeman, New York

FG

Lineweaver–Burk plot \rightarrow *Michaelis–Menten kinetics*

Lingane, James J.



(Sep. 13, 1909, St. Paul, Minnesota, USA, – Mar. 14, 1994, Lexington, Massachusetts, USA) Lingane received both

his baccalaureate (1935) and doctoral (1938) degrees in chemistry at the University of Minnesota. His Ph.D. work with \rightarrow *Kolthoff* was some of the earliest in the U.S. in the area of \rightarrow *polarography*, and was of intense interest following \rightarrow *Heyrovský's* visit to Minnesota (and other universities in the U.S.) in 1933. After instructorships for one year at Minnesota and 2 years at the University of California at Berkeley, he moved to Harvard University and remained there until his retirement in 1976.

Lingane was a leader in the field of \rightarrow *electroanalytical chemistry* and wrote, with Kolthoff, the definitive, two volume monograph, *Polarography* [i] that remains a useful reference work. He also helped develop other electroanalytical techniques, like controlled potential electrolysis, \rightarrow *coulometry*, \rightarrow *coulometric titrations*, and developed an early electromechanical (Lingane–Jones) \rightarrow *potentiostat*. He wrote the widely-used monograph in this field, “*Electroanalytical Chemistry*” (1st edn., 1953; 2nd edn., 1958). Lingane received a number of awards, including the Analytical Chemistry (Fisher) Award of the American Chemical Society in 1958. Many of his Ph.D. students, e.g., \rightarrow *Meites*, Fred Anson, Allen Bard, Dennis Peters, and Dennis Evans, went on to academic careers in electrochemistry.

Refs.: [i] Kolthoff IM, Lingane JJ (1941) *Polarography. Polarographic analysis and voltammetry. Amperometric titrations*. Interscience, New York; 2nd edn: Kolthoff IM, Lingane JJ (1952, reprinted 1965) vol. 1: *Theoretical principles, instrumentation and technique*. vol. 2: *Inorganic polarography, organic polarography, biological applications, amperometric titrations*. Interscience, New York; [ii] Faulkner LR (1994) *Talanta* 41:1613

AJB

Lipophilicity — The affinity of a molecule or a part of a molecule for a lipophilic environment. For molecules and ions it is commonly measured by its distribution behavior in a biphasic system, either liquid–liquid (by determining the logarithm of the partition coefficient $\log(P)$ in octan-1-ol/water [i, ii]) or solid/liquid (retention on reversed-phase high-performance liquid chromatography (RP-HPLC), or thin-layer chromatography (TLC) system). (Alternative term is *Hydrophobicity*.)

For a compound *i*, the partition coefficient is defined as: $P_i = a_i(o)/a_i(w)$, where $a_i(o)$ and $a_i(w)$ stand for the \rightarrow *activities* of the compound *i* in octan-1-ol and water, respectively. In general, the more positive value of $\log(P)$, measured in the biphasic system of octan-1-ol/water, means the higher lipophilicity of the investigated system. See also \rightarrow *hydrophobic effect*, and \rightarrow *ice-berg structure*.

Refs.: [i] Leo A, Hansch C, Elkins D (1971) *Chem Rev* 71:525; [ii] Testa B, van der Waterbeemd H, Folkers G, Guy R (2001) *Pharmacokinetic optimization in drug research*. Wiley-VCH, Weinheim, pp 275–304

RG

Liposomes → Vesicles built up from molecules having a hydrophobic chain and a polar head group, as e.g., lecithins [i]. These molecules arrange in a double-walled shell (bilayer) with the polar groups facing the aqueous environment. Liposomes can be unilamellar (one bilayer) or multilamellar, they can be filled with smaller liposomes, or contain only an aqueous solution. Their radii may range from 20 nm to some hundred micrometers. Liposomes are important transport vesicles in living systems. At → *mercury electrodes* they adhere and disintegrate in a complex reaction sequence to form islands of an adsorbed monolayer [ii].

Refs.: [i] Lasic D (1993) *Liposomes. From physics to applications*. Elsevier, Amsterdam; [ii] Hellberg D, Scholz F, Schubert F, Lovrić M, Omanović D, Agmo Hernández V, Thede R (2005) *J Phys Chem B* 109:14715

FS

Lippmann, Gabriel Jonas



(© The Nobel Foundation)

(Aug. 16, 1845, Hollerich, Luxembourg – July 12, 1921, on an overseas voyage return from America). Lippmann was appointed as professor of mathematical physics in 1878 at the Faculty of Science in Paris. Later he became professor of experimental physics succeeding Jamin. This position he held until his death. In 1873 he was appointed to a Government scientific mission visiting Germany to study methods for teaching science. Thus he worked with Kühne and Kirchhoff in Heidelberg and with → *Helmholtz* in Berlin. In Heidelberg he studied electrocapillary phenomena and invented the first version of what later became known as the → *Lippmann capillary electrometer* [i, ii]. His research on electrocapillaries lead to the → *Lippmann equation*, and was fundamental for the entire development of electrochemistry in allowing to gain a detailed understanding

of the structure and properties of electrode interfaces. Lippmann was awarded the Nobel Prize for Physics in 1908 for his development of an interference-based color photography.

Refs.: [i] Lippmann G (1873) *Ann Phys* 225:546 (also referred to as: *Pogg Ann* 149:546); [ii] Lippmann G (1875) *Ann Chim Phys* 5:494

FS

Lippmann capillary electrometer — Instrument to measure either small voltages (or charges), or the interfacial tension between mercury and solutions. It was developed by → *Lippmann* [i, ii]. This electrometer is based on the dependence of the surface tension of a mercury electrode on electrode potential (→ *electrocapillary curve*, → *Lippmann equation*). Figure 1 depicts the instrument as published by Lippmann in [ii]. The mercury is situated in a wide glass tube A connected with rubber tubes to a glass tube with the platinum wire α that makes the electrical contact to the mercury having the meniscus M in the glass tube G'G. Above the mercury meniscus is the aqueous solution that fills also the bent glass tube H and communicates with the solution above the mercury in the beaker. The beaker contains a bottom mercury electrode that is electrically contacted via β . Any change of the → *Galvani potential difference* at the mercury|aqueous solution interface will affect the height of the mercury column in the capillary. Figure 2a shows the instrument as depicted by

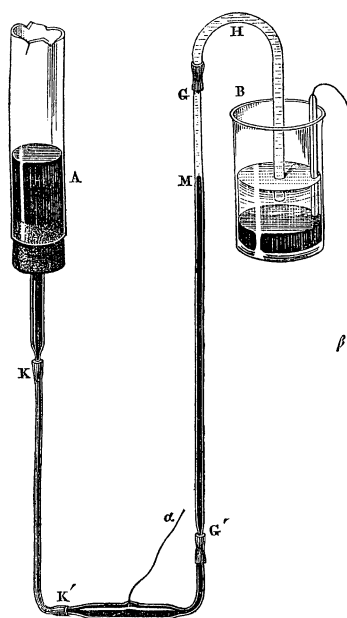

Lippmann capillary electrometer — Figure 1. Lippmann capillary electrometer [ii]. For explanation see text

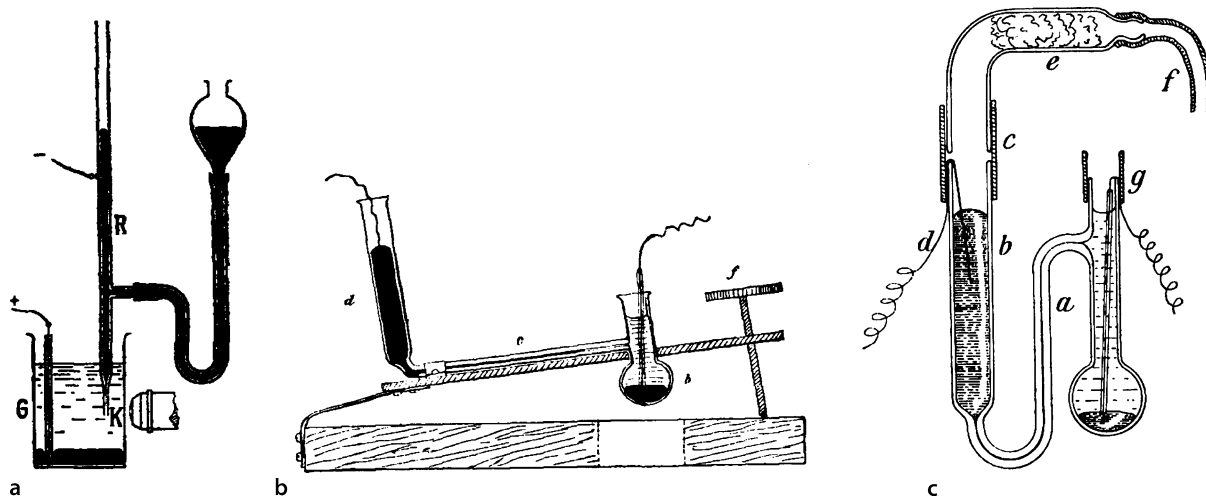

Lippmann capillary electrometer — Figure 2. (a), (b), (c) from left to right: Lippmann capillary electrometers. (Reproduced (a) from [iii], and (b) and (c) from [iv]). For explanation see text and sources

Freundlich [iii]: A mercury column is situated in a capillary that is open on both ends. If the surface tension of the spherical mercury meniscus at the lower orifice is balanced by the weight of the mercury column, no mercury will flow out. When the potential of the mercury electrode versus the bottom mercury is changed, the surface tension will change and the height of the mercury column has to be adjusted accordingly to balance the changed surface tension. Several other versions of the Lippmann capillary electrometer were developed later [iv]. The following two are given by → Ostwald, F.W. and → Luther [iv]: Figure 2b shows a version where the capillary is slightly ascending versus the horizontal. Figure 2c depicts a version with a vertical capillary where the position of the meniscus is measured with a microscope. The Lippmann capillary electrometer allowed very sensitive studies of the relation between surface tension and → electrode potential (i.e., electrocapillary phenomena, → electrocapillary curve), and it was instrumental in the development of the idea of the → electrochemical double layer as a capacitor (→ Helmholtz). The Lippmann capillary electrometer is seldom used nowadays.

For measurement of interfacial tension see also → Wilhelmy plate (slide) method, → drop weight method, → ring method. There are also a number of other static and dynamic methods for the determination of interfacial tension [v].

Refs.: [i] Lippmann G (1873) *Ann Phys* 225:546 (also referred to as: *Pogg Ann* 149:546); [ii] Lippmann G (1875) *Ann Chim Phys* 5:494; [iii] Freundlich H (1922) *Kapillarchemie*, 2nd edn. Akademische Verlagsgesellschaft, Leipzig, p 391 (Engl transl: Freundlich H (1924) *Colloid & cap-*

illary chemistry. Maggs Bros, London); [iv] Ostwald W, Luther R (1902) *Hand- und Hilfsbuch zur Ausführung physiko-chemischer Messungen*, 2nd edn. W Engelmann, Leipzig, pp 333 (Engl ed: Ostwald W, Luther R, Drucker C (1943) *Manual of physical-chemical measurements*. Bibliodisia, Chicago); [v] Adamson AW, Gast AP (1997) *Physical chemistry of surfaces*, 6th edn. Wiley, New York, p 4–47

FS

Lippmann electrometer → Lippmann capillary electrometer

Lippmann equation — This is the relationship between the → surface tension, the → charge density, and the → potential applied to the → polarizable interface, for a fixed composition of a solution:

$$d\gamma = -QdE$$

This equation was first derived by → Lippmann in the course of his studies that led him to develop the → Lippmann capillary electrometer [i].

The charge density of a → double layer is: $Q = C(E - E_{zc})$, where C is the → differential capacity and E_{zc} is a → potential of zero charge, i.e., the potential of electro-capillary maximum. By integrating the Lippmann equation a relationship between the surface tension and the electrode potential is obtained: $\gamma = \gamma_{\max} - C(E - E_{zc})^2/2$. This is a parabola symmetrical about γ_{\max} , if C is independent of E [ii].

Refs.: [i] Lippmann G (1875) *Ann Chim Phys* 5:494; [ii] Bockris JO'M, Reddy AKN, Gamboa-Aldeco M (2000) *Modern electrochemistry*, vol. 2A. Kluwer/Plenum, New York, p 858, 875

ŠKL

Liquid junction — This is the locus where two electrolyte solutions meet, as it happens in many → *galvanic cells*, → *electrolysis cells*, and cells used in → *voltammetry* or other electrochemical measuring techniques. When the solvent of the two solutions is the same, e.g., water, or when the two solvents are miscible, the liquid junction is not in an equilibrium situation (unless both electrolyte solutions are identical). At liquid junctions → *liquid junction potentials* build up. They can be minimized by intersection of a solution containing a very high electrolyte concentration (→ *salt bridge*) [i]. Generally, one can distinguish the following types of junctions: (a) free-diffusion junctions, (b) restricted-diffusion junctions, (c) continuous-mixture junctions, (c) and flowing junctions. [ii] → *Flowing junctions* possess a very constant and highly reproducible liquid junction potential. For liquid junctions between immiscible electrolyte solutions see → *interface between two immiscible electrolyte solutions*. See also → *electrolyte junction*.

Refs.: [i] Bard AJ, Faulkner LR (2001) *Electrochemical methods*, 2nd edn. Wiley, New York, p 72; [ii] Newman J, Thomas-Alyea KE (2004) *Electrochemical systems*, 3rd edn. Wiley Interscience, Hoboken, pp 150

FS

Liquid junction potential — (also called junction potentials) At the interface between liquids of different composition kept from immediate intermixing by, e.g., a porous glass frit or a ceramic disk (see → *salt bridge*) a liquid junction potential may be established. Three different situations are conceivable:

1. Solutions with the same constituents at different concentrations.
2. Solutions with different constituents at the same concentrations.
3. Solutions with different constituents at different concentrations.

As a consequence, different ionic movements may result (only impeded by the mechanical separator):

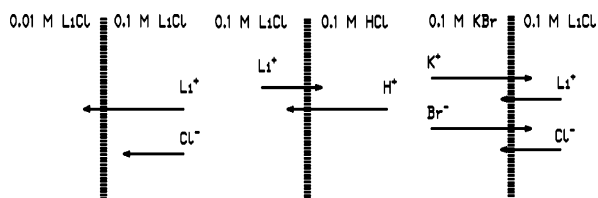

Liquid junction potential — Figure

The indicated ionic movements are based on the different concentrations and → *ionic mobilities*:

Liquid junction potential — Table. Mobility of ions in water ($T = 298\text{ K}$)

Cations	$u/\text{cm}^2\text{ s}^{-1}\text{ V}^{-1}$	Anions	$u/\text{cm}^2\text{ s}^{-1}\text{ V}^{-1}$
H ⁺	36.23×10^{-4}	OH ⁻	20.64×10^{-4}
Li ⁺	4.01×10^{-4}	NO ₃ ⁻	7.40×10^{-4}
Na ⁺	5.19×10^{-4}	Cl ⁻	7.91×10^{-4}
K ⁺	7.62×10^{-4}	Br ⁻	8.09×10^{-4}
Ba ²⁺	6.59×10^{-4}	HCO ₃ ⁻	4.61×10^{-4}
Zn ²⁺	5.47×10^{-4}	SO ₄ ²⁻	8.29×10^{-4}

Due to the different mobilities, concentration gradients and thus potential gradients will be established. In actual measurements these potentials will be added to the electrode potentials. A calculation of liquid junction potential is possible with the → *Henderson equation*. As liquid junction potential is an undesired addition in most cases, methods to suppress liquid junction potential like → *salt bridge* are employed. (See also → *diffusion potentials*, → *electrolyte junction*, → *flowing junctions*, and → *MacInnes*.)

A completely different situation arises at the interface between → *immiscible liquids* where ion transfer may occur.

Refs.: [i] Bard AJ, Faulkner LR (2001) *Electrochemical methods*, 2nd edn. Wiley, New York; [ii] Holze R (1989) *Leitfaden der Elektrochemie*. Teubner, Stuttgart; [iii] Newman J, Thomas-Alyea KE (2004) *Electrochemical systems*, 3rd edn. Wiley Interscience, Hoboken, pp 149

RH

Liquid-liquid interfaces → *interface between two liquid solvents*

Lithium batteries — Lithium batteries are → *batteries* that have lithium metal → *anodes*. The term lithium battery actually refers to a family of different chemistries, comprising many types of → *cathodes* and → *electrolytes*. Primary cells using lithium anodes have many advantages, such as high voltage (up to 4 V), high specific energy and energy density (over 200 Wh kg⁻¹ and 400 Wh L⁻¹), operation over a wide temperature range from about - 40 °C to 70 °C, good power density, flat discharge characteristics, and superior shelf life (up to 10 years) [i]. The discharge reaction for the lithium anode is the oxidation of Li for lithium ions, Li⁺, with the release of an electron:



The cathode materials used in primary lithium batteries are SO₂, SOCl₂, SO₂Cl₂, (CF)_n, MnO₂, CuS, FeS,

FeS₂, etc. [i]. Polar organic liquids such as acetonitrile, γ -butyrolactone, dimethylsulfoxide, 1,2-dimethoxyethane, dioxolane, propylene carbonate, and methyl formate are the most common solvents for electrolyte solutions in primary Li cells. Thionyl chloride (SOCl₂) and sulfuryl chloride (SO₂Cl₂) are inorganic compounds that serve as both the solvent and the active cathode material in primary Li batteries [i].

Lithium batteries are used in many portable consumer electronic devices and are also widely used in industry. The most common type of lithium cell used in consumer applications comprises metallic lithium as the anode and manganese dioxide as the cathode, with a Li salt such as Li perchlorate or Li tetrafluoroborate dissolved in an organic solvent. Lithium batteries find application in many long-life, critical devices such as cardiac pacemakers and other implantable electronic medical devices. These devices use special lithium-iodide batteries designed to last 15 years or more. Lithium batteries can be used in place of ordinary alkaline cells in many devices such as clocks and cameras. Although they are more expensive, lithium cells provide a much longer life, and thereby minimize battery replacement.

Small lithium batteries are commonly used in small, portable electronic devices such as watches, thermometers, calculators, etc., as backup batteries in computers and communication equipment, and in remote-control car locks. They are available in many shapes and sizes, with the common variety being a 3-volt “coin”-type manganese battery, 20 mm in diameter and 1.6–4 mm thick. The heavy electrical demands of many of these devices make lithium batteries a particularly attractive option. In particular, lithium batteries can easily support the brief and heavy current demands of devices such as digital cameras. They also maintain a higher voltage for a longer period than alkaline cells.

Lithium batteries can provide extremely high currents and can be discharged very rapidly when short-circuited. Although this is useful in applications where high currents are required, a too-rapid discharge of a lithium battery can result in the overheating of the battery, rupture, and even explosion. Lithium-thionyl chloride batteries are particularly capable of high-rate discharge. Consumer batteries usually incorporate overcurrent or thermal protection or vents in order to prevent thermal runaway and explosion. Because of the above risks, shipping and cartage of lithium batteries is restricted in some situations, particularly the transport of lithium batteries by air.

Rechargeable lithium batteries, with Li metal as the anode, were developed during the 80s and early 90s of

the 20th century, but never became widely-used commercial products due to safety and performance problems related to the use of highly reactive Li metals in the cell (e.g., nonuniform Li deposition-dissolution forms a highly reactive area that consumes the electrolyte solution). The limits and drawbacks to the use of Li metal in rechargeable batteries led to the development of Li-ion batteries during the early 90s, when Li metal was replaced by Li-carbon intercalation compounds. Li-ion batteries can store more than twice the energy per unit weight and volume than other rechargeable batteries [ii]. They contain negative and positive Li intercalation electrodes (usually, graphite/carbon and transition metal oxide), and electrolyte solutions that usually comprise alkyl carbonate solvents and LiPF₆. The first commercially successful rechargeable lithium battery, introduced by the Sony Corporation in 1990, consisted of a carbon-based negative electrode, layered lithiated cobalt oxide LiCoO₂ as the positive electrode, and a nonaqueous liquid electrolyte [iii]. Electrolytes based on ethylene carbonate, diethyl or dimethyl carbonates, comprising salts like LiPF₆, LiAsF₆, LiClO₄, are commonly used in Li-ion batteries.

A typical chemical reaction of the Li-ion battery is as follows:

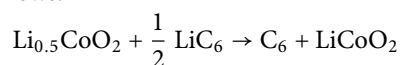

The high cost and toxicity of cobalt compounds has prompted a search for alternative materials that intercalate lithium ions. Examples of these are LiMn₂O₄ [iv], LiCo_{0.2}Ni_{0.8}O₂, LiNi_{0.5}Mn_{1.5}O₄ [v], LiNi_{0.5}Mn_{0.5}O₂ [vi], LiFePO₄ [vii], Li_xVO_y [viii], and Li_xM_yVO_z (M = Ca, Cu) [ix], etc.

Currently, three types of graphite material are in use in Li-ion manufacturing – artificial graphite, mesophase carbon microbeads (MCMB), and natural graphite. Tin-based amorphous and silicon-based materials, as well as titanium oxides, are potential anode materials for Li-ion batteries with some unique and useful characteristics [x]. For instance, Li₄Ti₅O₁₂ spinel has a operating voltage of about 1.5 V vs. lithium for the Ti⁴⁺/Ti³⁺ redox couple, which is above the reduction potential of common electrolyte solvents. Thus, a solid electrolyte interface based on solvent reduction is not formed. This should be favorable for high rate and low temperature operation [xi, xii]. The 1.5 V insertion potential removes the danger of lithium plating that can occur at high rates and/or at low temperature when the conventional carbonaceous anode is used.

A schematic charge-discharge processes and the overall reaction of a lithium-ion battery using carbon (neg-

ative) and a LiMO_2 (positive) electrode is shown in the figure.

Lithium-ion batteries are commonly used in consumer electronics. They are currently one of the most popular types of battery, with one of the best energy-to-weight ratios, no “memory effect”, and a slow loss of charge when not in use. However, they can be dangerous if mistreated, and unless care is taken they may have a short lifespan compared to other battery types.

A unique drawback to the Li-ion battery is that its lifespan is dependent upon aging, from time of manufacture (shelf life) regardless of whether it was charged, and not just on the number of charge/discharge cycles. At a 100% charge level, a typical Li-ion laptop battery, which is kept fully charged most of the time at 25 °C, will irreversibly lose approximately 20% of its capacity per year. This capacity loss begins from the time it was manufactured, and occurs even when the battery is unused. Different storage temperatures produce different loss results: a 6% loss at 0 °C, 20% at 25 °C, and 35% at 40 °C. When stored at a 40% charge level, these figures may be reduced to 2%, 4%, 15% at 0, 25, and 40 °C, respectively. Li-ion batteries are not as durable as NiMH or NiCd designs and can be extremely dangerous if mistreated. Lithium-ion batteries have a nominal voltage of

3.6 V and a typical charging voltage of 4.2 V. The charging procedure usually includes operation at a constant current until a voltage of 4.2 V is reached by the cell, and then continuing with a constant voltage applied until the current drops close to zero.

The development of rechargeable Li batteries based on solid electrolyte should also be mentioned. It is possible to prepare Li-ion-conducting matrices with a gel structure that comprises polymers, such as a solid, flexible structure, a Li salt (electrolyte), and polar aprotic solvents such as alkyl carbonates and plasticizers. The Li ion is conducted by salt dissolved in the solvent. The use of solid electrolytes improves safety features, enables flexible design, and allows an increase in the energy density by using Li metal as an anode. The drawbacks are lower rates, and worse, low temperature performance. Compared to the systems based on liquid electrolytes, there are also developments of rechargeable Li batteries based on all-solid electrolyte systems. These may include polyethers (polymers), which can dissolve Li salts or thin films of conducting ceramic materials, glass, or Li salts (e.g., Li_3O_4). This field is very dynamic and attracts a great deal of attention from the scientific and technological communities in materials science, physics, and chemistry. Attempts are being made to push Li-ion

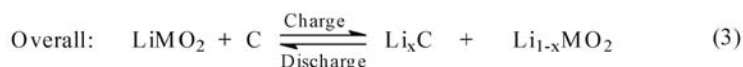
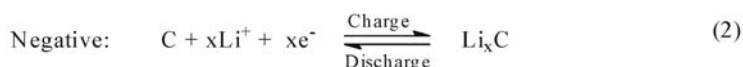
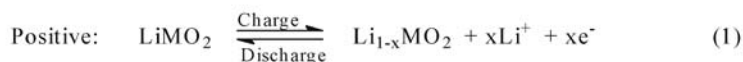
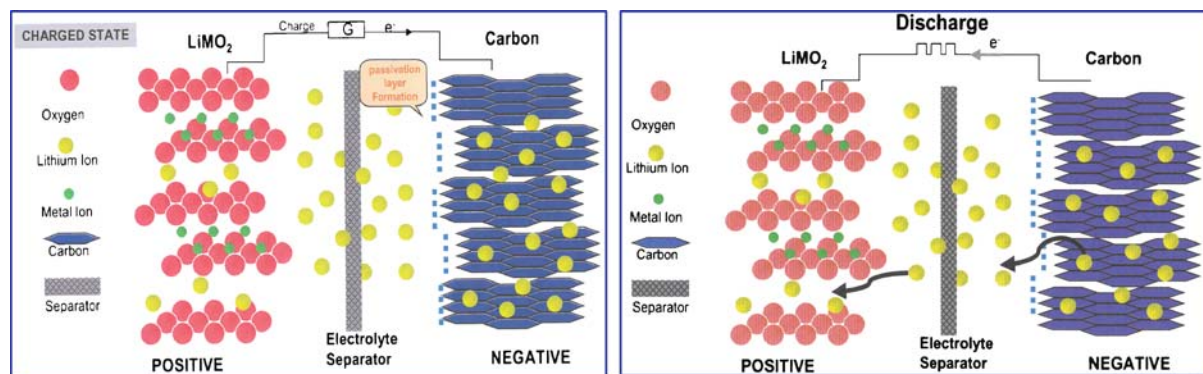

technology towards demanding uses such as electric vehicles by investing novel, high capacity/high rate materials through the use of nanotechnology.

Refs.: [i] Linden D, Reddy TB (2002) *Lithium batteries*. In: Linden D, Reddy TB (ed) *Handbook of batteries*. McGraw-Hill, New York, pp 14.1–14.106; [ii] Oyama N, Tatsuo T, Sato T, Sotomura T (1995) *Nature* 373:598; Scrosati B (1995) *Nature* 373:557; [iii] Nagaura T (1990) 3rd Int Battery Seminar. Deerfield Beach, FL, USA; [iv] Thackeray MM, David WIF, Bruce PG, Goodenough JB (1983) *Mater Res Bull* 18:461; [v] Dokko K, Mohamedi M, Anzue N, Itoh T, Uchida I (2002) *J Mater Chem* 12:3688; Sun K, Hong KJ, Prakash J, Amine K (2002) *Electrochem Comm* 4:344; [vi] Spahr ME, Novak P, Schnyder B, Haas O, Nesper R (1998) *J Electrochem Soc* 145:1113; Lu Z, MacNeil DD, Dahn JR (2001) *Electrochem Solid State Lett* 4:A191; Ohzuku T, Makimura Y (2001) *Chem Lett* 30:744; [vii] Padhi AK, Nanjundaswamy KS, Goodenough JB (1997) *J Electrochem Soc* 144:1188; Anderson AS, Kalska B, Haggstrom L, Thomas JO (2000) *Solid State Ionics* 130:41; Yamada A, Chung SC, Hinokuma K (2001) *J Electrochem Soc* 148:A224; [viii] Thackeray MM (1999) *The structural stability of transition metal oxide insertion electrodes for lithium batteries*. In: Besenhard JO (ed) *Handbook of battery materials*. Wiley-VCH, Weinheim, pp 293–321; [ix] Morcrette M, Rozier P, Dupont L, Mugnier E, Sannier L, Galy J, Tarascon JM (2003) *Nat Mater* 2:755; [x] Courtney IA, Dunlap RA, Dahn JR (1999) *Electrochim Acta* 45:51; [xi] Ohzuku T, Ueda A, Yamamoto N (1995) *J Electrochem Soc* 142:1431; Kanamura K, Umegaki T, Naito H, Takehara Z, Yao T (2001) *J Appl Electrochem* 31:73; [xii] Ehrlich GM (2002) *Lithium-ion batteries*. In: Linden D, Reddy TB (ed) *Handbook of batteries*. McGraw-Hill, New York, pp 35.1–35.94

DA, BMA

Lithium cation conductors → *solid electrolyte*

Lithium-conducting solid electrolyte → *solid electrolyte*

Local element — A combination of two metals showing different standard potentials staying in electrically conducting connection, i.e., a steel screw connecting aluminum sheets or a copper washer on a zinc plate. When this combination is covered with an ionically conducting (electrolyte) solution the less noble metal may act as anode and be subject to dissolution (i.e., → *corrosion*) whereas at the more noble metal merely oxygen reduction proceeds. Such an “electrochemical cell” may also be called a short-circuit cell or short-circuit element. It is a major source of damage due to corrosion by unsuitable materials combination. Inserting an insulating material (e.g., a polymer washer) or selecting suitable metal combinations may avoid the problem. A most effective application of local elements is the use of metal combinations resulting in the establishment of a → *sacrificial anode* in corrosion protection. A local element can also be established at an interface between an electrolyte solution and

an electronically conducting material composed of only a single constituent when the electrode potential established at the interface varies as a function of localization by, e.g., changes in the composition of the solution. Locally increased oxygen concentration (by, e.g., supply of air) may result in less positive potentials as compared to regions with lower oxygen concentration. Corrosion may thus proceed at the latter place with higher rate. This local element is also called aeration element.

RH

Lock-in amplifiers → *amplifiers*, subentry → *lock-in amplifier*

Lockwood cell — This was a variant of the → *Daniell cell*. See also → *zinc*, → *Zn²⁺/Zn electrodes*, → *Zn²⁺/Zn(Hg) electrodes*, → *zinc-air batteries (cell)*, and → *Leclanché cell*.

Ref.: [i] Hauck WP (1883) *Die Galvanischen Batterien, Accumulatoren und Thermosäulen*, 2nd edn. Hartleben's Verlag, Wien

FS

Loeb, Jacques



(Reproduced from *Journal of General Physiology*, 1928, 8:lxiii–xciii. Copyright 1928, Rockefeller University Press)

(Apr. 7, 1859, Mayen, Germany – Feb. 11, 1924, Hamilton, The Bermuda Islands, UK) Loeb studied at the Universities of Berlin, Munich, and Strassburg, where he studied brain physiology and took a medical degree in 1884. Following some time in Berlin he joined the group of → *Fick* in Würzburg. He continued his career in Strassburg, Naples, and Zurich, and in 1891 he moved to the USA accepting a position at the Bryn Mawr College. In 1892 he joined the University of Chicago and also led the Department of Physiology at the MBL, Woods Hole. In 1902 he went to the University of California, and from 1910 he worked at The Rockefeller Institute for Medical Research. Together with W.J.V. Osterhout he founded the *Journal of General Physiology* [i–iii]. Loeb was an outstanding physiologist who was convinced that the processes of life can only be understood on the basis of physical chemistry, and thus he helped very much in putting

physiology on a strictly scientific basis. He strongly supported the application of the ion theory of → *Arrhenius* in physiology, studied different kinds of tropism, amongst which was → *galvanotropism*. Together with → *Beutner* he studied the origin of → *electromotive forces* in living organisms [iv–xi]. A complete bibliography of his publications is available in [xii].

Refs.: [i] Osterhout WJV (1928) *J Gen Physiol* 9:8; [ii] Höber R (1924) *Klin Wochenschr* 3:510; [iii] Freundlich H (1924) *Naturwiss* 12:602; [iv] Loeb J, Beutner R (1911) *Science* 34:884; [v] Loeb J, Beutner R (1912) *Biochem Z* 41:1; [vi] Loeb J, Beutner R (1912) *Science* 35:970; [vii] Loeb J, Beutner R (1912) *Biochem Z* 44:303; [viii] Loeb J, Beutner R (1913) *Science* 37:672; [ix] Loeb J, Beutner R (1913) *Biochem Z* 51:288; [x] Loeb J, Beutner R (1913) *Biochem Z* 51:300; [xi] Loeb J, Beutner R (1914) *Biochem Z* 59:195; [xii] Kobelt N (1928) *J Gen Physiol* 8:LXI

FS

log c–pH diagrams — Diagrams in which the logarithm of the concentrations of the species of protolysis reactions or other electrolyte systems are plotted versus the pH. For a two-basic acid with the following equilibria

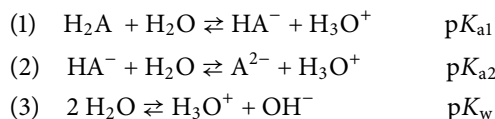

($pK_a = -\log K_a$, K_a acidity constant, $pK_w = -\log K_w$, K_w ion product of water) the following figure shows the log c–pH diagram. The real dependencies are hyperbola; however, usually it is sufficient to plot the asymptotes of the hyperbola, because significant deviations between the hyperbola and their asymptotes occur only for pH values around the pK_a values. Such diagrams were in-

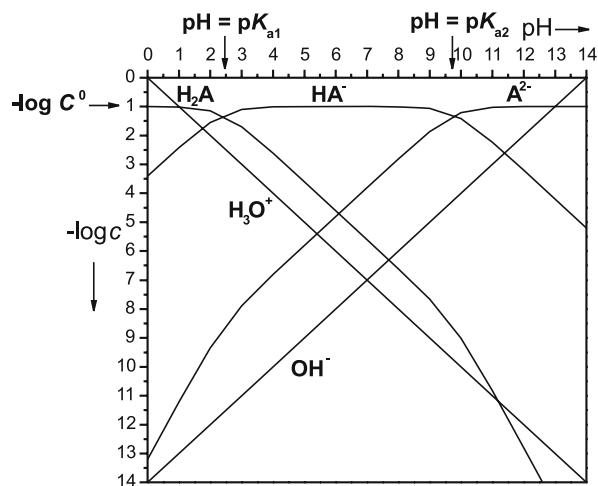

log c–pH diagrams — Figure. log c–pH diagram for a di-basic acid in aqueous solution with the analytical (overall) concentration of C^0 , and the two pK_a values: pK_{a1} and pK_{a2}

troduced by → *Bjerrum* [i] and have been made popular by Hägg (Dec. 14, 1903 – May 28, 1986) [ii, iii]. This is the reason that the diagrams are also referred to as Hägg diagrams. They are of great value in understanding the composition of acid–base electrolyte solutions, for the derivation of titration plots, etc. [iv].

Refs.: [i] Bjerrum N (1915) *Sammlung chemisch und chemisch-technischer Vorträge* 21:1; [ii] Hägg G (1950) *Die theoretischen Grundlagen der analytischen Chemie*. Birkhäuser, Basel; [iii] Magnéli A (1987) *J Appl Chryst* 20:1; [iv] Butler JN (1998) *Ionic equilibria. Solubility and pH calculations*. Wiley, New York

FS

Logarithmic analysis → semi-logarithmic plot

Logarithmic titration curve — A sigmoidal shaped → *titration curve* in which the → *cell voltage* or a → *p-function* of the → *titrand* or → *titrant* is plotted as a function of the volume of titrant added. The most important measurements are confined near and surrounding the middle segment of the sigmoid in which the → *equivalence point* is found [i]. See also → *linear titration curve*.

Ref.: [i] Harris D (2002) *Quantitative chemical analysis*. WH Freeman, New York

FG

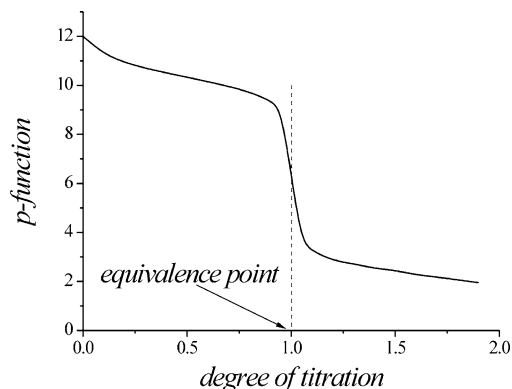

Logarithmic titration curve — Figure

London forces (or “dispersion forces”) — are forces attracting apolar molecules due to their mutual → *polarizability*. London forces are also components of the forces between polar molecules. The London equation approximately describes respective energy of interactions, $V_L = -C/r^6$, where C is constant dependent on energy of ionization and polarizabilities of both molecules and r is the distance between the molecules. See also → *van der Waals forces*, and → *Casimir force*.

Ref.: [i] Muller P (1994) *Pure Appl Chem* 66:1077

WK

Low-pass filter → *signal filtering*

Long path length optical cell — An optical cell that is used for spectroscopic measurements. Optical cells with long path length are usually utilized for quantitative and qualitative detection of dissolved traces in solutions and gas phase species. The length of long length optical cells can be varied from few centimeters to tens of meters depending on the system under analysis. Long path is usually important to enhance the spectral signal by increasing the total amount of absorbing species in the sample. It is commonly used in IR and UV → *spectroscopy*, in transmittance mode.

Refs.: [i] Jackson K, Bowman EL, Fulton LJ (1995) *Anal Chem* 67(14):2368; [ii] Silva ML, Sonnenfroh DM, Rosen DI, Allen MG, Keefe AO (2005) *Appl Phys B* 81(5):705

OC, DA

Low-amplitude perturbation — A potential perturbation (rarely a current perturbation) whose magnitude is small enough to permit linearization of the exponential terms associated with the relevant theory [i]. See for example → *electrochemical impedance spectroscopy* where low-amplitude voltage perturbations (usually sinusoidal) are the sole perturbations; see also AC → *polarography* where, historically, a small amplitude voltage perturbation was imposed on a DC ramp [ii].

Refs.: [i] Kissinger PT, Ridgway TH (1996) *Small-amplitude controlled-potential techniques*. In: Kissinger PT, Heineman WR (eds) *Laboratory techniques in electroanalytical chemistry*, 2nd edn., Marcel Dekker, New York, pp 141; [ii] Smith DE (1966) *AC polarography and related techniques: theory and practice*. In: Bard AJ (ed) *Electroanalytical chemistry*, vol. 1. Chap. 1 Marcel Dekker, New York

AMB

Lowry, Thomas Martin



(Reproduced courtesy of the Library and Information Center of the Royal Society of Chemistry)

(Oct. 26, 1874, Bradford, West Riding, UK – Sep. 2, 1936, Cambridge, UK) Lowry is most well-known for his → *acid-base theory* that he developed independent

of and simultaneous to → *Brønsted* in 1923. As a physical chemist he worked on the optical activity of organic compounds and discovered mutarotation. In 1920 he became the first professor of physical chemistry at Cambridge University.

Ref.: [i] Lowry TM (1923) *Chem Ind* 42:43

FS

Luggin, Hans



(Photo reproduced from [x])

(June 24, 1863, Klagenfurt, Austria – Dec. 5, 1899, Klagenfurt, Austria) [i, ii] Luggin studied physics from 1881 to 1888 in Vienna, Strassburg, and Prague, where he received his Ph.D. in 1888. The following year he was at the Universities of Vienna and Graz, and from 1894–96 he worked at the University of Stockholm (Sweden) with → *Arrhenius* [iii]. In 1896 he habilitated [iii] at the Technical University of Karlsruhe (Germany), where → *Haber* habilitated in the same year in chemistry. Luggin is well-known for the so-called → *Luggin capillary (probe)*, which he had suggested to *Haber*, what the latter acknowledged in [iv]. Luggin published on photoelectric effects (→ *photoelectrochemistry*), photography, and → *electrocapillary* effects, and on polarization of very thin metal → *membranes* [v–viii].

Refs.: [i] (1972) *Österreichisches Biographisches Lexikon 1815–1950*, vol. 5. Böhlau, Wien, p 357; [ii] *Arrhenius S (1900) Z Elektrochem* 6:50; [iii] Kernbauer A (1988) *Svante Arrhenius' Beziehungen zu österreichischen Gelehrten*. Akademische Druck- und Verlagsanstalt, Graz; [iv] Luggin H (1897) *Über die photoelektrischen Erscheinungen und den photographischen Prozeß*. Karlsruhe, Universität; [v] *Haber F (1900) Z phys Chem* 32:193; [vi] *Luggin (1894) Z phys Chem* 14:385; [vii] *Luggin H (1897) Z phys Chem* 23:577; [viii] *Luggin H (1895) Z phys Chem* 16:677; [ix] *Luggin H (1895) Ann Phys Chem* 56:347; [x] *Riesefeld EH (1931) Svante Arrhenius*. Akademische Verlagsgesellschaft B.M.H., Leipzig, p 40/41

FS

Luggin capillary (probe) — Device for the elimination (or better reduction) of the → *IR drop* in electrochemical

measurements. It is usually a bent glass tube with a large enough opening to accommodate a \rightarrow *reference electrode* (immersed in the background electrolyte solution) and a usually much smaller opening only large enough to ensure the ionic conduction. By locating the smaller opening close to the surface of a \rightarrow *working electrode*, the influence of IR drop can be minimized. However, it must not be placed too close, otherwise the diffusion of redox species toward the working electrode may be blocked. See also \rightarrow *Luggin*.

Ref.: Kahlert H (2002) *Reference electrodes*. In: Scholz F (ed) *Electroanalytical methods*. Springer, Berlin, pp 272–276

TO

FS

L

Luminescence spectroscopy \rightarrow *spectroscopy*

LUMO — Acronym for “Lowest Unoccupied Molecular Orbital”, which together with the \rightarrow *HOMO* are called frontier orbitals.

Ref.: [i] Levine IN (1991) *Quantum chemistry*. Prentice-Hall, New Jersey

IH

Luther, Robert Thomas Diederich



(Jan. 2, 1868, Moscow, Russia – Apr. 17, 1945, Dresden, Germany.) German physical chemist who studied chemistry from 1885–1889 in Dorpat, Russia (now Tartu, Estonia). Luther was assistant at the Technological Institute of St. Petersburg (Russia) from 1889–1891. In subsequent years he studied at the University of Leipzig where he received his Ph.D. in 1896, habilitated in 1899, and became an assistant professor at the Institute of \rightarrow *Ostwald, F.W.* From 1908–1935 he was professor in Dresden (Germany) where he was director of the Photographic Institute. In his Leipzig period he worked mainly in electrochemistry, and developed a very

sensitive capillary electrometer (\rightarrow *Lippmann capillary electrometer*). He also found what is now known as \rightarrow *Luther's rule*. Together with Wilhelm Ostwald he wrote a standard book on electrochemical laboratory techniques [i]. Luther also introduced the term ‘electrode of the third kind’ (\rightarrow *electrode*) [ii]. In his later life he concentrated on photochemistry.

Refs.: [i] Ostwald W, Luther R (1902) *Hand- und Hilfsbuch zur Ausführung physiko-chemischer Messungen*, 2nd edn. W Engelmann, Leipzig (Engl ed: Ostwald W, Luther R, Drucker C (1943) *Manual of physical-chemical measurements*. Bibliodisica, Chicago); [ii] Luther R (1899) *Z phys Chem* 27:364

Luther's rule \rightarrow Luther studied the relation between the standard electrode \rightarrow *potentials* of metals that can exist in more than one oxidation state. For some electrochemically reversible systems (\rightarrow *reversibility*) he showed theoretically and experimentally that for a metal Me and its ions Me^+ and Me^{2+} the following relation holds (in contemporary nomenclature) for the \rightarrow *Gibbs energies* of the redox transitions:

$$\Delta G_{\text{M}/\text{M}^+}^{\ominus} + \Delta G_{\text{M}^+/\text{M}^{2+}}^{\ominus} = \Delta G_{\text{M}/\text{M}^{2+}}^{\ominus} \cdot$$

With $\Delta G^{\ominus} = -nFE^{\ominus}$ (n number of transferred electrons for both half-reactions, F is the \rightarrow *Faraday constant*) follows for the relation of the standard \rightarrow *potentials*:

$$E_{\text{M}/\text{M}^+}^{\ominus} + E_{\text{M}^+/\text{M}^{2+}}^{\ominus} = 2E_{\text{M}/\text{M}^{2+}}^{\ominus}$$

For the more general case

- $\text{Me} \rightarrow \text{Me}^{n_1+} + n_1 e^-$
- $\text{Me}^{n_1+} \rightarrow \text{Me}^{(n_1+n_2)+} + n_2 e^-$
- $\text{Me} \rightarrow \text{Me}^{(n_1+n_2)+} + (n_1 + n_2) e^-$

the following relations follow for the standard Gibbs free energies and the standard potentials:

$$\begin{aligned} \Delta G_{\text{M}/\text{M}^{n_1+}}^{\ominus} + \Delta G_{\text{M}^{n_1+}/\text{M}^{(n_1+n_2)+}}^{\ominus} &= \Delta G_{\text{M}/\text{M}^{(n_1+n_2)+}}^{\ominus} \\ n_1 F E_{\text{M}/\text{M}^{n_1+}}^{\ominus} + n_2 F E_{\text{M}^{n_1+}/\text{M}^{(n_1+n_2)+}}^{\ominus} & \\ &= (n_1 + n_2) F E_{\text{M}/\text{M}^{(n_1+n_2)+}}^{\ominus} \end{aligned}$$

Refs.: [i] Luther R (1899) *Z phys Chem* 30:628; [ii] Luther R, Wilson R (1900) *Z phys Chem* 34:489; [iii] Luther R (1901) *Z phys Chem* 36:385

FS

M

MacInnes, Duncan Arthur



(March 31, 1885, Salt Lake City, Utah, USA – Sept. 23, 1965, Hanover, N.H., USA) [i] MacInnes graduated with a B.S. degree in chemical engineering from the University of Utah in 1907, and did his graduate work in electrochemistry at the University of Illinois. In 1917 he moved to the Massachusetts Institute of Technology and became Associate Professor in 1921. In 1926 he was invited to join the Rockefeller Institute as Associate Member, and in 1940 he became a Member, a position that he held until 1950 when he became Emeritus Member. MacInnes made numerous contributions to electrochemistry, e.g., experimentally verifying the → *Debye–Hückel theory* of electrolyte solutions [ii], developing a low-resistance glass for → *glass electrodes* (the so-called MacInnes-type glass or 015 pH Corning Glass: 22% Na₂O, 6% CaO, 72% SiO₂) [iii], improving the → *moving boundary method* to determine → *transference numbers* of ions [iv], studies on the dependence of the acidity constants of organic acids on their constitution [v], and studies on → *liquid junction potentials* [vi]. MacInnes invented the use of a ‘→ *retarded electrode*’ for differential potentiometric titrations [vii]. MacInnes also wrote an influential textbook [viii].

Refs.: [i] Longworth LG, Shedlovsky T (1965) *J Electrochem Soc* 112:262C; [ii] MacInnes DA (1921) *J Am Chem Soc* 43:1217; MacInnes DA, Cowperthwaite JA (1927) *Trans Faraday Soc* 23:400; [iii] MacInnes DA, Dole M (1929) *Ind Eng Chem Anal* 1:57, 457; MacInnes DA, Dole M (1930) *J Am Chem Soc* 52:29; [iv] MacInnes DA, Smith ER (1923) *J Am Chem Soc* 45:2246; MacInnes DA, Smith ER (1924) *J Am Chem Soc* 46:1398; MacInnes DA, Brighton TB (1925) *J Am Chem Soc* 47:994, 1009; MacInnes DA, Cowperthwaite JA, Blanchard KC (1926) *J Am Chem Soc* 48:1909; MacInnes DA, Cowperthwaite JA,

Huang TC (1927) *J Am Chem Soc* 49:1710; [v] MacInnes DA (1928) *J Am Chem Soc* 50:2587; [vi] MacInnes DA (1915) *J Am Chem Soc* 37:2301; MacInnes DA (1915) *Proc Natl Acad Sci* 1:526; [vii] MacInnes DA, Jones PT (1926) *J Am Chem Soc* 48:2831; MacInnes DA, Dole M (1929) *J Am Chem Soc* 51:1119; [viii] MacInnes DA (1939) *The principles of electrochemistry*. New York (reprinted 1961)

FS

Macropores (macroporosity) → *porous electrodes*

Madelung constant — is the factor by which the ionic charges must be scaled to calculate the electrostatic interaction energy of an → *ion* in a crystal lattice with given structure, and the total lattice energy of ionic crystals. This constant is solely determined by the geometrical arrangement of point charges, and has the same value for all compounds having identical structure. The electrostatic interaction energy, called often the Madelung energy, is the main contribution to the total binding energy of lattices with predominantly ionic bonding.

Ref.: [i] Kittel C (1996) *Introduction to solid state physics*, 7th edn. Wiley, Chichester

VK

Magnesium batteries → *Batteries* that utilize metallic magnesium as anode. Magnesium anode-based batteries belong to several very different families of batteries. All these batteries are aimed to take advantage of the high theoretical → *charge capacity* of magnesium and its low redox potential in order to realize high energy density batteries. Commercial magnesium batteries include: i) **Aqueous magnesium–manganese oxide** primary cells, used primarily for military application. These exhibit higher energy density than zinc–carbon cells (→ *Leclanché cell*), with relatively flat discharge curves, excellent shelf life and good power. These batteries suffer from very rapid → *self-discharge* after putting into service. ii) **Magnesium water-activated** batteries belong to the family of reserve batteries. These come with a variety of cathodes, such as AgCl, CuCl, CuSCN, Cu₂Cl₂ and MnO₂. These cells come in various designs, each targeted at different application. In general, except for high energy density, these cells possess exceptional shelf life, owing to their reserve-battery design. Additionally, there are several magnesium batteries that are experimental, or in various stages of development: iii) **Magnesium–air** batteries are also aqueous, primary batteries, but these use oxygen from the air for reduction at the cathode. Although much effort has been devoted for their development, up to date they have not been commercialized. iv) **Magnesium–organic solvent**

primary batteries, that have been proposed, coupled with a variety of cathode materials, among them, meta-dinitrobenzene, have reached an advanced development stage. v) **Rechargeable magnesium** batteries, based on organic solvents, organo-halo aluminum and magnesium complex salts, with Mo_6S_8 chevrel phase cathode. These cells exhibit very long cycle life with moderate \rightarrow energy density.

Refs.: [i] Crompton TR (2000) *Battery reference book*, 3rd edn. Newnes, Oxford, chap 10, 11, 17, 25, 39, 57, 58, 63; [ii] Spellman PJ, Larsen DM, Ekern RJ, Oxley JE (1994) *Magnesium and aluminum cells*. In: Linden D (1994) *Handbook of batteries*, 2nd edn. McGraw-Hill, New York, pp 9.5–9.15; [iii] Koontz RA (1994) *Magnesium water-activated batteries*. In: Linden D (1994) *Handbook of batteries*, 2nd edn. McGraw-Hill, New York, pp 17.1–17.25. [iv] Aurbach D, Lu Z, Schechter A, Gofer Y, Gizbar H, Turgeman R, Cohen Y, Moshkovich M, Levi E (2000) *Nature* 407:724

YG, DA

Magnesium electrochemistry — can be considered in regard to the media in which the magnesium electrode is in contact with, i.e., aqueous or nonaqueous solutions, or molten salts. As magnesium is one of the electropositive (or “of the least noble”) elements, with redox potential of -2.38 V, the metal reacts spontaneously with water, yielding hydrogen gas and magnesium ions. Nevertheless, numerous studies involving aqueous magnesium electrochemistry have been published, and aqueous magnesium batteries are commercially available. Magnesium batteries are characterized by a relatively high \rightarrow energy density, owing to the low molecular weight, 24.3 g mol^{-1} , of the metal, and its low (very negative) reversible potential. As an important construction material, many aqueous electrochemical studies have concentrated on the anodic \rightarrow passivation of magnesium and magnesium alloys as a means for protection from the environment against \rightarrow corrosion. Magnesium is utilized also for cathodic protection electrodes for steel in underground pipelines and marine environments. Recently, magnesium attracted also attention with regard to the electrochemistry of hydrogen storage alloys, proposed to be superior for metal-hydride-based batteries. Another latest interest in aqueous magnesium electrochemistry concentrates on deposition of MgB_2 high-temperature superconductor.

Magnesium ions are important players in the biochemistry and physiology of most plants and other living organisms. Of special interest is the role of magnesium ions in the transmittance of nerve signals, and in the potential differences across membranes developed by magnesium ion concentration gradients. Numerous bioelec-

trochemical studies have been published in the last two decades in this field.

Magnesium electrochemistry in molten salts media is especially important for the mass production of the pure metal. Magnesium is frequently produced and refined by electrolysis of high-temperature, molten eutectic mixtures of anhydrous MgCl_2 with various salts, such as KCl , CaCl_2 etc. High-temperature molten salts baths, with similar compositions, with the addition of borate are also studied for the production of MgB_2 .

Interest in the nonaqueous electrochemistry of magnesium has its roots in the early 20th century, mainly as an analytical means for the study of the chemistry of Grignard reagents, RMgX , R-organic ligand, e.g., alkyl, aryl, X-halogen e.g., Cl, Br). Also, during the second half of the 20th century scattered papers have been published on the nonaqueous electrochemistry of magnesium, in relation to magnesium \rightarrow electrodeposition and \rightarrow batteries. During the eighties it was established that magnesium forms a compact passivation layer when in contact with common organic solvents-based solution. Only at the turn of the century feasible rechargeable magnesium battery chemistry was developed, based on ethers as solvents, complexes of organo-halo aluminum and magnesium compounds, and intercalation cathode based on Chevrel-phase molybdenum sulfide.

Refs.: [i] Crompton TR (2000) *Battery reference book*, 3rd edn. Newnes, Oxford, chap 10, 11, 17, 25, 39, 57, 58, 63; [ii] Wendt H, Kreysa G (1999) *Electrochemical engineering, science and technology*. In: *Chemical and other industries*. Springer Berlin, pp 342–345; [iii] Berger DM (1989) *Fundamentals and prevention of metallic corrosion*. In: Schweitzer PE (ed) *Corrosion and corrosion protection handbook*. Marcel Dekker, New York, pp 1–23; [iv] Ga XP, Wang Y, Lu ZW, Hu WK, Wu F, Song DY, Shen PW (2004) *Chem Mat* 16:2515; [v] Pawar SH, Shiragan PM, Shivagan DD, Jadhav AB (2004) *Mod Phys Lett B* 18:505; [vi] Schlue WR, Kilb W, Gunzel D (1997) *Electrochim Acta* 42:3197; [vii] Kipouros GJ, Sadoway DR (1987) *The chemistry and electrochemistry of magnesium production*. In: Mamantov G, Mamantov CB, Braunstein J (eds) *Advances in molten salt chemistry*, vol 6. Elsevier, Amsterdam, pp 127–209; [viii] Gaddum LW, French HE (1927) *J Am Chem Soc* 49:1295; [ix] Meitav A, Peled E (1979) *Extended Abstracts, Meeting – International Society of Electrochemistry* 30th 367–9; [x] Aurbach D, Lu Z, Schechter A, Gofer Y, Gizbar H, Turgeman R, Cohen Y, Moshkovich M, Levi E (2000) *Nature* 407:724; [xi] Perrault GG (1978) *Magnesium*. In: Bard AJ (ed) *Encyclopedia of the electrochemistry of the elements*, vol 8. Marcel Dekker, New York, pp 263–319

YG, DA

Magnetochemistry — Magnetochemistry is concerned with the influence of magnetic fields on electrochemical reactions. The most prominent and

so far best understood effect is the magnetohydrodynamic (MHD) effect. The MHD effect is mainly due to Lorentz forces which induce convection in the electrolyte and thus decrease the \rightarrow *diffusion layer thickness*. As a result, a slight increase of the limiting current density of an electrochemical reaction is observed if a magnetic field is applied perpendicular to the electric current. Another type of magnetic force which can be active in electrochemical reactions are gradient forces which arise from gradients of the magnetic field or concentration gradients of paramagnetic species (such as Mn^{2+} , Co^{2+} , Cu^{2+} , Ni^{2+}).

Refs.: [i] Fahidy TZ (1999) *The effect of magnetic fields on electrochemical processes*. In: Conway BE, Bockris JO'M, White RE (eds) *Modern aspects of electrochemistry*, vol 32. Kluwer/Plenum, New York, pp 333–354; [ii] Fahidy TZ (2001) *Progr Surf Sci* 68:155; [iii] *Special issue on magnetic effects in electrochemistry* (2007) *J Solid State Electrochem* 11:677–756

AB

Maiche cell — This \rightarrow *battery* was developed by Lois Maiche and it was a zinc–air battery. The oxygen electrode was from platinized carbon, and the electrolyte solution contained either an ammonia salt or sodium hydrogen-sulfate and sulfuric acid. See also \rightarrow *zinc*, \rightarrow *Zn²⁺/Zn electrodes*, \rightarrow *Zn²⁺/Zn(Hg) electrodes*, \rightarrow *zinc–air batteries (cell)*, and \rightarrow *Leclanché cell*.

Ref.: [i] Hauck WP (1883) *Die Galvanischen Batterien, Accumulatoren und Thermosäulen*, 2nd edn. Hartleben's Verlag, Wien

FS

Maintenance-free battery — A rechargeable \rightarrow *battery* that does not require replenishing of water during its service life. Usually the term refers to maintenance-free \rightarrow *lead-acid* and sealed nickel–cadmium batteries, which, in contrary to the conventional ones, are designed to suppress water loss due to \rightarrow *electrolysis* (overcharging) and evaporation.

Refs.: [i] Crompton TR (2000) *Battery reference book*, 3rd edn. Newnes, Oxford, pp 18/5–18/10; [ii] Carcone JA (1994) *Sealed nickel cadmium batteries*. In: Linden D (ed) *Handbook of batteries*, 2nd edn. McGraw-Hill, New York, pp 28.1–28.35; [iii] Hammel RO, Salkind AJ, Linden D (1994) *Sealed lead-acid batteries*. In: Linden D (ed) *Handbook of batteries*, 2nd edn. McGraw-Hill, New York, pp 28.1–28.35

YG

Mairanovskii, Stal Grigorievich



(Reprinted from *J. Electroanal. Chem.* 340(1992)1, Copyright (1992), with permission from Elsevier)

(Feb. 12, 1926, Moscow, USSR, now Russia – Sep. 28, 1991, Moscow, USSR, now Russia) [i] Mairanovskii studied Chemistry at the Lomonosov Institute of Fine Chemical Technology (Moscow) from 1943 to 1948. After graduation he worked at a pharmaceutical plant where he also started his electrochemical research. \rightarrow *Frumkin* discovered the young scientist and supported him until his death. Mairanovskii became a co-worker of Frumkin at the Institute of Electrochemistry (the later Frumkin Institute) in the years 1959–1961. In his Ph.D. thesis (Candidate of Chemistry, in the Soviet Union) supervised by Moisei B Neiman and defended in 1953, he developed the reaction scheme explaining catalytic hydrogen waves of organic compounds (\rightarrow *catalytic currents*). In 1962 he was awarded the degree of doctor of science (degree qualifying for a professor position) for the thesis “The theory of catalytic polarographic hydrogen evolution”. Since 1956 Mairanovskii worked at the N. D. Zelinskii Institute of Organic Chemistry, Moscow. He contributed to various fields of electrochemistry, however, his major contributions concern the experimental and theoretical studies of catalytic and other kinetic signals in \rightarrow *voltammetry* (mainly \rightarrow *polarography*). Mairanovskii published a monograph on catalytic hydrogen waves [ii], a book on polarography of organic compounds [iii], three other books, and more than 350 original publications.

Refs.: [i] Stradiņš J, Mairanovskii VG (1992) *J Electroanal Chem* 340:1 (Orbituary); [ii] Mairanovskii SG (1966) *Catalytic and kinetic waves in polarography*. Nauka, Moscow (Engl transl: Mairanovskii SG (1968) *Catalytic and kinetic waves in polarography*. Plenum Press, New York); [iii] Mairanovskii SG, Stradiņš J, Bezuglyi VD (1975) *Polarography in organic chemistry*. Khimia, Leningrad

FS

Manganese — A d-metal (transition metal) with the electronic configuration $1s^2 2s^2 2p^6 3s^2 3p^6 3d^5 4s^2$. This metal exists in a number of oxidation states, starting from Mn(II) (manganous), Mn(III) (manganic), Mn(IV) presented in a great variety of stoichiometric and nonstoichiometric manganese dioxides, Mn(V) (hypomanganates), Mn(VI) (manganate), and Mn(VII) (permanganate). Except for the hypomanganates, all these families of compounds are stable. Mn(II) is a strong reducing agent in alkaline medium, where it readily oxidizes. Mn(VII) is a strong oxidizing agent being usually reduced to Mn(II). Mn(IV) compounds form a family of host materials suitable for Li-ion intercalation, called sometimes in a broad sense “manganates”.

MnO₂ — Compounds based on crystallographically different forms of manganese (IV) dioxide. They are used frequently as cathodes in commercial primary and secondary MnO₂-Zn batteries (→ *Leclanche* and → *alkaline cells*), and are considered as perspective intercalation hosts for Li-ion insertion (3- and 4-V cathodes for rechargeable Li-ion batteries). Electrochemical activity along the 3 V discharge plateau is typical for layered (e.g., busenite and birnessite) and tunnel-structured variants (e.g., ramsdellite/rutile, α -MnO₂, hollondite, todorokite) of MnO₂. Although this discharge plateau region is also observed for the electrochemical insertion of Li ions into manganese spinel, the latter compound is basically considered as a 4-V cathode for Li-ion cells, since the cycle life of this material is superior in this voltage plateau over that at 3 V. Manganates are more abundant and are cheaper than the commonly used LiCoO₂ in commercial Li-ion cells which stimulates their further studies in R&D of Li-ion cells. Moreover, the toxicological aspects of the manganates are also better than those of the cobalt-based compounds.

Refs.: [i] Cotton FA, Wilkinson G (1972) *Advanced inorganic chemistry*, 3rd edn. Wiley, New York, p 845; [ii] Pistoia G (ed) (1994) *Lithium batteries: new materials, developments and perspectives*. Elsevier, Amsterdam, p 252; [iii] Nazri GA, Pistoia G (eds) (2004) *Lithium batteries: science and technology*. Kluwer, Dordrecht, p 344

ML

Marangoni streaming — A → *surface tension* gradient (due to local temperature or composition variation) induces a convection effect. Marangoni effects [i, ii] occur at liquid-gas or at liquid-liquid interfaces and result in convection or streaming in the liquid adjacent to the interface. See also → *polarographic maximum*.

Refs.: [i] Marangoni CGM (1871) *Ann Phys (Poggendorff)* 3:337; [ii] Sternling CV, Scriven LE (1959) *AIChE J* 5:514

FM

Marcus theory — describes theoretical aspects of single electron transfer reactions. The theory was originally developed by Rudolph A. Marcus to explain relatively simple outer sphere → *electron transfers* which do not involve rupture and formation of bonds but cause only changes in the so-called reorganization energy (λ , where $\lambda = \lambda_i + \lambda_o$) that describes changes in bond lengths in the reacting molecules (inner component, λ_i), and changes in the radii of solvated ions or in the → *solvation* sphere including orientation of the solvent dipoles (outer component, λ_o). Thus, Marcus theory relates the → *activation energy* of electron transfer reaction to λ . The whole concept was based on the energy conservation principle and the Franck-Condon principle. Fundamental equations were initially derived upon assumption of the adiabatic character of the processes [i, ii]. Transfers of electrons were assumed to occur practically at fixed positions of the ions and molecules in the system, and the electrons were expected to follow adiabatically changes in the coordinates of the → *ligands* (with respect to the central ion) without any change in quantum state. The theoretical aspects of single electron transfer reactions were also studied independently by → *Levich*, N. S. Hush, → *Dogonadze*, A. M. Kuznetsov. Modern charge transfer theory is extended to diabatic reactions as well, and considers quantitatively bond rupture, asymmetry of the innersphere reorganization, multielectron elementary steps, and other complex processes [iii].

The Marcus theory describes kinetic details of both homogeneous electron self-exchange reactions and heterogeneous electron transfer (electrode) processes. The Figure, illustrating the dependence of standard → *Gibbs energy* (G^\ominus) as a function of reaction coordinate, applies to the case of a heterogeneous reaction in which the oxidized (Ox) and reduced (Red) forms react at an electrode under the simplest assumption of parabolic terms (harmonic oscillation approximation) of equal curvature. Here λ is the energy difference between the bottom (minimum) of the left parabola (equivalent to the equilibrium energy level of substrates before the reaction) and a point vertically above on the upper part of the other parabola (equivalent to the energy level of the reaction products before any atomic positions have been changed). The crossing point of parabolas defines the standard free activation energy (ΔG_f^\ddagger) of the forward electrode process: $\Delta G_f^\ddagger = \lambda/4$. Thus the standard heterogeneous → *rate constant* (k_s) can be expressed: $k_s = \nu \exp(-\lambda/4RT)$, where R is → *gas constant*, T stands for absolute temperature, and ν is the vibration frequency of the atoms around their equilibrium positions. The re-

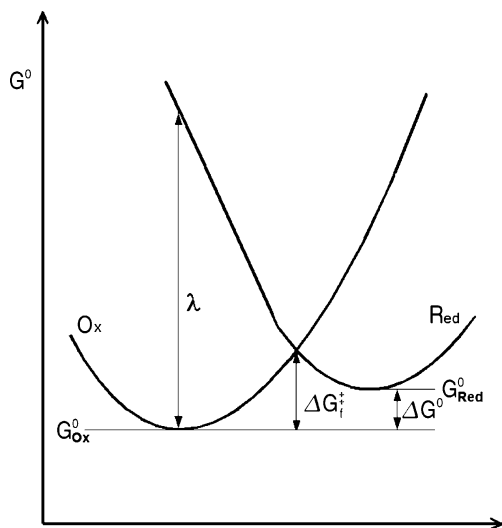

Marcus theory — Figure. Standard Gibbs energy, G^\ominus , as a function of reaction coordinate (q , horizontal axis) for an electron transfer reaction, for homogeneous or heterogeneous charge transfer reactions

organization energy (λ) depends strongly on the type of reaction and the solvent used. Similar diagrams can be drawn for homogeneous electron transfer reactions involving two different redox couples. In the case of electron self-exchange homogeneous processes, the equilibrium energy levels of substrates (G_{Ox}^\ominus) and products (G_{Red}^\ominus) are equal, and the standard Gibbs energy change (ΔG^\ominus) becomes 0.

Using the Marcus theory, the α value (see \rightarrow *charge-transfer coefficient*) can be predicted, and its dependence on the potential applied. For low \rightarrow *overpotentials*, and when neither Ox nor Red are specifically adsorbed on the electrode surface, α should be approximately equal to 0.5. Further, the theory describes the relation between homogeneous and heterogeneous rate constants characteristic of the same redox system. An interesting prediction from Marcus theory is the existence of a so-called “inverted region” for the homogeneous electron transfer reactions, of importance to the phenomenon of \rightarrow *electrogenerated chemiluminescence*. A similar region for heterogeneous reactions corresponds to \rightarrow *activationless processes*. Marcus theory has been successfully applied to explain the electron transfer processes during oxidation of metals (\rightarrow *corrosion*), photosynthesis, and in living matter, e.g., electron transport over large distances in redox proteins containing metal ions. R. A. Marcus received a Nobel Prize in Chemistry in 1992 [iv].
 Ref.: [i] Marcus RA (1956) *J Chem Phys* 24:966; [ii] Marcus RA (1965) *J Chem Phys* 43:679; [iii] Kuznetsov AM, Ulstrup J (1999) *Electron trans-*

fer in chemistry and biology. Wiley, Chichester; [iv] Marcus RA (1997) *Electron transfer reactions in chemistry: theory and experiment*. Nobel lecture, December 8, 1992. In: Malmström BG (ed) *Nobel lectures, chemistry 1991–1995*. World Scientific Publishing, Singapore, pp 69–92

PK, AL

Marié–Davy cell — This was a \rightarrow *Bunsen cell* with a carbon electrode in a paste of mercury sulfate, i.e., it was a zinc-mercury \rightarrow *battery*.

Ref.: [i] Hauck WP (1883) *Die Galvanischen Batterien, Accumulatoren und Thermosäulen*, 2nd edn. Hartleben’s, Verlag, Wien

FS

Mark, Harry Berst Jr.



(Reproduced from [i] with permission)

(Feb. 28, 1934, Camden, NJ, USA – Mar. 3, 2003, Cincinnati, OH, USA) Mark received a B.A. in chemistry from the University of Virginia and a Ph.D. from Duke University. He was postdoc at the University of North Carolina and at the California Institute of Technology. After a faculty position at the University of Michigan he served from 1970 until his death as Professor in the Chemistry Department of the University of Cincinnati. Mark was electrochemist and analytical chemist. His major contributions concern spectroelectrochemistry and conducting polymer electrodes. He was among the pioneers of kinetic methods of analysis. His scientific work is documented in over 300 publications and 14 books which he either has written or edited.

Ref.: [i] Heineman WR, Ridgway TH (2003) *J Solid State Electrochem* 7:251

FS

Markin–Volkov (MV) isotherm — Classical isotherms of \rightarrow *adsorption* (\rightarrow *Frumkin*, \rightarrow *Langmuir*) were based on the model of nonpenetrable interface, where an adsorbate can substitute only molecules of one solvent. However, at the interface between two immiscible electrolytes or liquid membranes, amphiphilic molecules can substitute molecules of both solvents. Therefore classical

isotherms are not applicable in these cases. The generalization of \rightarrow Langmuir and \rightarrow Frumkin isotherms for permeable and nonpermeable interfaces, known as the Markin–Volkov (MV) isotherm, makes it possible to analyze the adsorption and the interfacial structure in a general case:

$$\frac{\Theta [\eta - (\eta - 1)\Theta]^{p-1}}{\eta^p (1 - \Theta)^p} \exp(-2a\Theta) = \frac{(X_A^b)^r}{(X_o^b)^p (X_w^b)^{pn_w}} \exp\left(-\frac{\Delta_b^s G^\ominus}{RT}\right).$$

η is the ratio of areas occupied in the interface by the molecule of surfactant, a is the attraction constant, r is the interfacial aggregation number of surfactant molecules, X designates the mole ratio of corresponding substances, b is the bulk phase, A is the surfactant molecule, $\Delta_b^s G^\ominus$ is the Gibbs energy of adsorption equilibrium, Θ is the surface coverage, and p is a relative size of the surfactant molecule in the interfacial layer. If $\eta = p$ and the concentration of surfactant in the solution and the mutual solubility of oil and water is low, then we can use the approximation $X_o^b = X_w^b = 1$, so that the general equation simplifies to:

$$\frac{\Theta [p - (p - 1)\Theta]^{p-1}}{p^p (1 - \Theta)^p} \exp(-2a\Theta) = (X_A^b)^r \exp\left(-\frac{\Delta_b^s G^\ominus}{RT}\right).$$

This is the final expression for the Markin–Volkov (MV) isotherm. It is straightforward to derive classical adsorption isotherms from the MV isotherm:

1. The Henry isotherm, when $a = 0$, $r = 1$, $p = 1$, $\Theta \ll 1$: $\Theta = X_a^b \exp\left(-\frac{\Delta_b^s G^\ominus}{RT}\right)$.
2. The Freundlich isotherm, when $a = 0$, $p = 1$, $\Theta \ll 1$: $\Theta = (X_a^b)^r \exp\left(-\frac{\Delta_b^s G^\ominus}{RT}\right)$.
3. The Langmuir isotherm, when $a = 0$, $r = 1$, $p = 1$: $\frac{\Theta}{1 - \Theta} = X_a^b \exp\left(-\frac{\Delta_b^s G^\ominus}{RT}\right)$.
4. The Frumkin isotherm, when $r = 1$, $p = 1$: $\frac{\Theta}{1 - \Theta} \exp(-2a\Theta) = X_a^b \exp\left(-\frac{\Delta_b^s G^\ominus}{RT}\right)$.

Therefore, the MV isotherm could be considered as a generalization of the Langmuir and Frumkin isotherms, taking into account the replacement of solvent molecules by larger molecules of surfactant.

Refs.: [i] Volkov AG, Deamer DW, Tanelian DI, Markin VS (1998) *Liquid interfaces in chemistry and biology*. Wiley, New York; [ii] Volkov AG,

Markin VS (2004) *Electric properties of oil/water interfaces*. In: Petsev DN (ed) *Emulsions: structure stability and interactions*. Elsevier, Amsterdam, pp 91–182

AV

Masking agent — An auxiliary \rightarrow ligand that is added to a sample in order to avoid unwanted interference of a metal ion in a complex formation analysis. A suitable masking agent has to react selectively and form a sufficiently stable complex with the interfering component so that its reaction with the ligand used as \rightarrow titrant is prevented [i].

Ref.: [i] Perrin DD (1970) *Masking and demasking of chemical reactions*. Wiley Interscience, New York

FG

Mass distribution ratio (in micellar electrokinetic chromatography), k_{MEKC} — Defined as:

$$k_{\text{MEKC}} = \frac{n_{\text{mc}}}{n_{\text{aq}}} = K \cdot \frac{V_{\text{mc}}}{V_{\text{aq}}}$$

where n_{mc} and n_{aq} is the chemical amount of the \rightarrow analyte in the micellar and aqueous phase, respectively, K is the distribution constant, and V_{mc} and V_{aq} are the corresponding volumes of the phases. In case of an electrically neutral analyte, k_{MEKC} can be calculated directly from the relevant migration times:

$$k_{\text{MEKC}} = \frac{(t_m - t_{\text{eo}})}{t_{\text{eo}} (1 - t_m/t_{\text{mc}})},$$

where t_m , t_{eo} , and t_{mc} is \rightarrow migration time, \rightarrow electroosmotic hold-up time, and \rightarrow migration time of micelles, respectively. k_{MEKC} should not be confused with the retention factor (in column chromatography) k . However, k_{MEKC} is analogous to the \rightarrow mass distribution ratio (in chromatography).

Ref.: [i] Riekkola ML, Jönsson JÅ, Smith RM (2004) *Pure Appl Chem* 76:443

WK

Mass distribution ratio in microemulsion electrokinetic chromatography, k_{MEEKC} — Defined analogously to the \rightarrow mass distribution ratio (in \rightarrow micellar electrokinetic chromatography), k_{MEKC} , by replacing terms for micelles with corresponding terms for microemulsion.

Ref.: [i] Riekkola ML, Jönsson JÅ, Smith RM (2004) *Pure Appl Chem* 76:443

WK

Mass transfer \rightarrow mass transport processes

Mass transfer coefficient → *steady state*

Mass transport coefficient — Symbol: k_m or k_d ; unit: m s^{-1} .

Mass transport coefficient (also called mass transport rate coefficient, mass transfer coefficient, heterogeneous diffusion rate constant) is defined as

$$k_{d,B} = D_B/\delta \quad (1)$$

which can be determined by measuring the → *limiting current* which is associated with the → *diffusion* of species B of concentration c_B and of → *diffusion coefficient* D_B :

$$k_{d,B} = I_{L,B}/nFc_BA \quad (2)$$

where n is the → *charge number of the cell reaction* written so that the stoichiometric coefficient of this species is unity. A is usually taken as the geometric area of the electrode. δ is the → *diffusion layer thickness*; because it is often unknown, it is the very reason why $k_{d,B}$ was introduced.

Refs.: [i] Parsons R (1974) *Pure Appl Chem* 37:503; [ii] Ibl N (1981) *Pure Appl Chem* 53:1827; [iii] Bard AJ, Faulkner LR (2001) *Electrochemical methods, 2nd edn*. Wiley, New York, pp 30–31; [iv] Inzelt G (2002) *Kinetics of electrochemical reactions*. In: Scholz F (ed) *Electroanalytical methods*. Springer, Berlin, pp 35–36.

GI

Mass transport overpotential (or concentration polarization (overpotential)) η_c — is a departure of the → *electrode potential* (or cell potential), E , from the → *equilibrium electrode potential* (or zero-current potential), E_{eq} , caused by a → *faradaic current flow* and the associated surface concentration, $c_{\text{Ox}}(x=0)$, deviation from the bulk concentration, $c_{\text{Ox}}(\infty)$, of the reacting redox species, Ox.

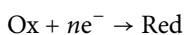

$$\eta_c = E - E_{\text{eq}} = \frac{RT}{nF} \ln \frac{c_{\text{Ox}}(x=0)}{c_{\text{Ox}}(\infty)}.$$

If net cathodic current flows then this potential is shifted negatively. Concentration polarization (alternatively called → *mass-transport polarization* or → *concentration overpotential*) is encountered if the rate of transport of the redox reactant to the electrode surface is lower than that of the → *charge-transfer reaction*. Together with the charge-transfer or → *activation polarization (overpotential)*, η_a , and the polarization (overpotential) due to a preceding chemical reaction, η_{rxn} , (see

→ *reaction overpotential*) the concentration polarization (overpotential) contributes to the overall electrode or cell polarization (overpotential), η .

$$\eta = E - E_{\text{eq}} = \eta_c + \eta_a + \eta_{\text{rxn}}$$

Refs.: [i] Bockris JO'M, Reddy AKN, Gamboa-Aldeco M (2000) *Modern electrochemistry, vol. 2A, Fundamentals of electrochemistry*. Kluwer, New York; [ii] Bard AJ, Faulkner LR (2001) *Electrochemical methods, 2nd edn* Wiley, New York; [iii] Purushothaman BK, Morrison PW Jr, Landau U (2005) *J Electrochem Soc* 152:J33

WK

Mass transport processes → *diffusion*, → *migration*, and → *convection* are the three possible mass transport processes accompanying an → *electrode reaction*. Diffusion should always be considered because, as the reagent is consumed or the product is formed at the electrode, concentration gradients between the vicinity of the electrode and the bulk solution arise, which will induce diffusion processes. Reactant species move in the direction of the electrode surface and product molecules leave the interfacial region (→ *interface*, → *interphase*) [i–v]. The → *Nernst–Planck equation* provides a general description of the mass transport processes. Mass transport is frequently called mass transfer; however, it is better to reserve that term for the case that mass is transferred from one phase to another phase.

Refs.: [i] Inzelt G (2002) *Kinetics of electrochemical reactions*. In: Scholz F (ed) *Electroanalytical methods*. Springer, Berlin, pp 29–30; [ii] Erdey-Grúz T (1972) *Kinetics of electrode processes*. Akadémiai Kiadó, Budapest, pp 17–20; [iii] Bard AJ, Faulkner LR (2001) *Electrochemical methods, 2nd edn*. Wiley, New York, pp 49–52; [iv] Parsons R (1974) *Pure Appl Chem* 37:503; [v] Parsons R (1979) *Pure Appl Chem* 52:233

GI

Maxwell's equations — A set of equations describing how an → *electromagnetic field* propagates. In vacuum, these equations can be written as:

$$\nabla \cdot \vec{E} = 0 \quad (1)$$

$$\nabla \cdot \vec{H} = 0 \quad (2)$$

$$\nabla \times \vec{E} = -\mu_0 \frac{\partial \vec{H}}{\partial t} \quad (3)$$

$$\nabla \times \vec{H} = \varepsilon_0 \frac{\partial \vec{E}}{\partial t} \quad (4)$$

where \vec{E} and \vec{H} indicate the electric and magnetic fields, whereas ε_0 and μ_0 correspond to the electric → *permittivity*

tivity and magnetic permeability of free space, respectively. Taking the curl of Eqs. (3) and (4) results in:

$$\begin{aligned}\nabla \times \nabla \times \vec{E} &= \nabla (\nabla \cdot \vec{E}) - \nabla^2 \vec{E} = \\ &= -\mu_0 \frac{\partial (\nabla \times \vec{H})}{\partial t} = -\mu_0 \frac{\partial (\epsilon_0 \frac{\partial \vec{E}}{\partial t})}{\partial t} = -\mu_0 \epsilon_0 \frac{\partial^2 \vec{E}}{\partial t^2} \\ \nabla \times \nabla \times \vec{H} &= \nabla (\nabla \cdot \vec{H}) - \nabla^2 \vec{H} = \\ &= \epsilon_0 \frac{\partial (\nabla \times \vec{E})}{\partial t} = \epsilon_0 \frac{\partial (-\mu_0 \frac{\partial \vec{H}}{\partial t})}{\partial t} = -\mu_0 \epsilon_0 \frac{\partial^2 \vec{H}}{\partial t^2}.\end{aligned}$$

Since from Eqs. (1) and (2): $\nabla (\nabla \cdot \vec{E}) = \nabla (\nabla \cdot \vec{H}) = 0$, the following second-order partial differential equations that describe the propagation of \rightarrow electromagnetic waves in a vacuum are obtained:

$$\begin{aligned}\nabla^2 \vec{E} &= \frac{1}{c_0^2} \frac{\partial^2 \vec{E}}{\partial t^2} \\ \nabla^2 \vec{H} &= \frac{1}{c_0^2} \frac{\partial^2 \vec{H}}{\partial t^2}\end{aligned}$$

where c_0 is the speed of light in vacuum and it is commonly replaced by c to indicate this speed in other media. The solution of these equations gives:

$$\begin{aligned}\vec{E}(\vec{r}, t) &= \vec{E}_0 \cos(\omega t - \vec{k} \cdot \vec{r} + \phi_0) \\ \vec{H}(\vec{r}, t) &= \vec{H}_0 \cos(\omega t - \vec{k} \cdot \vec{r} + \phi_0)\end{aligned}$$

where \vec{E}_0 and \vec{H}_0 are the magnitudes of the fields and related by $|\vec{H}_0| = |\vec{E}_0| c^{-1}$, ω is the angular frequency, \vec{k} is the wave vector, \vec{r} is the position vector, and ϕ_0 is the phase angle. The electric and magnetic fields are orthogonal and propagate in the same direction that is given by: $\vec{E} \times \vec{H}$ [i, ii].

Refs.: [i] Reitz J, Milford F, Christy R (1992) *Foundations of electromagnetic theory*. Addison Wesley, New York; [ii] Battaglia F, George TF (1990) *Notes in classical and quantum physics*. Blackwell Scientific Publications, Oxford

Maxwell–Wagner effect \rightarrow dielectric relaxation

Mean — The average value computed from a set of data sampled under repeatability conditions. When the number of observations approaches to infinity, the mean of such a huge set of data is called \rightarrow population mean (μ),

otherwise the term \rightarrow sample mean \bar{x} is used to indicate that the set of data is limited [i].

Ref.: [i] Mendham J, Denney R, Barnes J, Thomas M (2000) *Vogel's quantitative chemical analysis*. Prentice Hall, New Jersey

FG

Measuring electrode \rightarrow working electrode

Median — The middle value of a set of data sampled under repeatability conditions, and that has been arranged in order of size. For an even number of observations, the mean of the middle pair is used [i].

Ref.: [i] Harris D (2002) *Quantitative chemical analysis*. WH Freeman, New York

FG

Mediator \rightarrow redox mediator

Meites, Louis



(Courtesy of Petr Zuman, USA)

(Dec. 8, 1926, Baltimore, PA, USA – June 13, 1993, Fairfax, VA, USA) Meites graduated from Middlebury College (1945), was awarded the PhD at Harvard University (1947), taught at Princeton (1947–48), Yale (1948–55), the Polytechnic Institute of Brooklyn (1955–67), and became a chairman of the Department of Chemistry in what was then Clarkson College of Technology of Chemistry (1968–1984) and became Clarkson University, where he taught till 1984, when he became a chairman of the Chemistry Department at the George Mason University. His main area of interest was \rightarrow electroanalytical chemistry; he was one of the leading pioneers of \rightarrow polarography [i] in the USA. He studied mechanisms of oxidation-reduction processes mostly of inorganic systems, developed techniques using controlled potential electrolysis, as well as the use of thermochemistry in the study of kinetics of chemical reactions and was one of the early pioneers in the area now called chemometrics, which he used in treatment of electrochemical data.

FG

His experience in mechanistic studies was most valuable in critical evaluation of numerous mechanisms in the preparation of the largest existing collection of electrochemical data [ii, iii]. Meites was an excellent teacher of analytical chemistry [iv, v] and an editor of the "Handbook of Analytical Chemistry" [vi], containing numerous electrochemical data, such as redox potentials, pK_a values, stability constants, etc. Author of 204 publications, he was the founding editor of "Critical Reviews in Analytical Chemistry" and served on the commission of IUPAC dealing with electroanalytical chemistry. He received the Benedetti-Pichler Award (1983) for his achievements in analytical chemistry.

Refs.: [i] Meites L (1955) *Polarographic techniques*. Interscience, New York; (1965) 2nd edn. Wiley, New York; [ii] Meites L, Zuman P et al. (1977–83) *Handbook series in organic electrochemistry*, vols. I–VI. CRC Press, Boca Raton; [iii] Meites L, Zuman P et al. (1976–88) *Handbook series in inorganic electrochemistry*, vols. I–VIII. CRC Press, Boca Raton; [iv] Meites L, Thomas HC (1958) *Advanced analytical chemistry*. McGraw-Hill, New York; [v] Meites L (1981) *An introduction to chemical equilibria and kinetics*. Pergamon Press, Oxford; [vi] Meites L (ed) (1963) *Handbook of analytical chemistry*. McGraw-Hill, New York

PZ

Membrane — Thin, typically planar structure or material separating two phases. It has finite volume. Membranes can selectively control the mass transport between different phases. Some membranes exert ion selectivity. In this case the \rightarrow *membrane potential* arises.

Refs.: [i] Koryta J (1982) *Ions, electrodes and membranes*. Wiley, New York; [ii] Buck RP, Lindner E (1994) *Pure Appl Chem* 66:2527; [iii] <http://www.iupac.org/goldbook/M067878>

MO

Close meshed membrane electrode \rightarrow *membrane electrode* with large-meshed membrane. The small pores of its membrane allow diffusion of ions and molecules up to a certain size. Its potential is equal to the \rightarrow *Donnan potential*.

Ref.: [i] Kahlert H (2002) *Potentiometry*. In: Scholz F (ed) *Electroanalytical methods*. Springer, Berlin

MO

Glass membrane \rightarrow *glass electrode*

Large meshed membrane electrode \rightarrow *membrane electrode* with large-meshed membrane. The pores of its \rightarrow *membrane* are large enough to allow diffusion of all \rightarrow *ions*. Therefore rapid mixing of inner and outer \rightarrow *electrolyte* is possible. Its \rightarrow *potential* is equal to the \rightarrow *diffusion potential*.

Ref.: [i] Kahlert H (2002) *Potentiometry*. In: Scholz F (ed) *Electroanalytical methods*. Springer, Berlin

MO

Membrane electrode — After immersion into \rightarrow *electrolyte* solution it can be represented as \rightarrow *inner reference electrode*|inner \rightarrow *electrolyte* solution| \rightarrow *membrane*|outer \rightarrow *electrolyte* solution.

Among other factors its performance depends on the \rightarrow *membrane* properties. Its potential is equal to the potential across the membrane. It can be measured with high \rightarrow *input impedance* voltmeters versus an outer \rightarrow *reference electrode* present in an outer \rightarrow *electrolyte* solution. In some cases \rightarrow *inner reference electrode* and inner electrolyte solution can be eliminated, see for example \rightarrow *coated-wire electrodes*. This term is very often used as synonym of \rightarrow *ion-selective electrode*.

Apart of this traditional meaning, recently the term of membrane electrode (assembly) is used. It is defined as two electrodes (the anode and the cathode) with a very thin layer of catalyst, bonded to either side of an ion-exchange membrane. It is an element of polymeric membrane \rightarrow *fuel cell*.

Refs.: [i] Koryta J (1982) *Ions, electrode and membranes*. Wiley, New York; [ii] Kahlert H (2005) *Potentiometry*. In: Scholz F (ed) *Electrochemical methods*. Springer, Berlin; [iii] Vielstich W, Lamm A, Gasteiger H (2003) *Handbook of fuel cells – fundamentals, technology, applications*. Wiley-VCH, Chichester

MO

Membrane potential \rightarrow *Donnan potential*

Membrane system — It can be represented as \rightarrow *electrolyte* A|L \rightarrow *membrane* R| \rightarrow *electrolyte* B.

L and R represent the regions just inside a \rightarrow *membrane*, in direct contact with \rightarrow *electrolyte*. The \rightarrow *potential* drop across the membrane consists of two \rightarrow *Donnan potentials* associated with \rightarrow *ion* exchange on the left and right side of the membrane and the \rightarrow *diffusion potential* due to the concentration gradient within the \rightarrow *membrane*.

Refs.: [i] Koryta J (1982) *Ions, electrode and membranes*. Wiley, New York; [ii] Fawcett WR (2004) *Liquids, solutions and interfaces*. Oxford University Press, Oxford

MO

Porous membrane \rightarrow *Membrane* made of porous material. When it separates liquid phases its performance depends on the size of the pores and chemical properties of the material. If pore size is much larger than the molecular dimensions, the membrane exerts no influence on transport of individual components of separated liquids and only prevents mixing by convection. For smaller pores it selectively controls transport of species between the phases discriminating them by the size and/or charge. See also \rightarrow *membrane system*, \rightarrow *membrane electrode*.

Ref.: [i] Koryta J (1982) *Ions, electrodes and membranes*. Wiley, New York

MO

Semipermeable membrane electrode → *membrane electrode* with membrane permeable only for limited type of ionic species. Its potential is equal to the → *Donnan potential*. The electrode with the membrane permeable only for one type of ionic species is called → *ion selective electrode* used in → *potentiometry*.

Refs.: [i] Koryta J (1982) *Ions, electrodes and membranes*. Wiley, New York; [ii] Fawcett WR (2004) *Liquids, solutions and interfaces*. Oxford University Press, Oxford

MO

Thick membrane electrode → *membrane electrode* with membrane thick enough to allow to build up → *Donnan potentials* at membrane–solution interface and diffusion potential within the membrane. → *Glass electrode* is an example despite the small thickness of glass membrane.

Ref.: [i] Kahlert H (2002) *Potentiometry*. In: Scholz F (ed) *Electroanalytical methods*. Springer, Berlin

MO

Membrane cell process → *alkali chloride electrolysis*

Membrel® cell — (**m**embrane **e**lectrolysis) Electrochemical cell developed by BBC Brown Boveri Ltd, now joined with ASEA AB, to ABB Asea Brown Boveri Ltd) for water electrolysis. A polymeric cation exchange membrane acting as → *solid electrolyte* is placed between a catalyst-coated porous graphite plate acting as cathode and a catalyst-coated porous titanium plate acting as anode.

RH

Mercury and mercury electrodes — Symbol: Hg, Atomic number: 80, Atomic mass: 200.59 g mol⁻¹

A metal which exists at room temperature in liquid state (melting point: -38.87 °C) and possesses high → *surface tension* (0.483 J m⁻² at 25 °C) and density (13.534 g cm⁻³). These properties of Hg and its high → *overpotential* for hydrogen reduction makes it an excellent → *electrode material*. Mercury electrodes are additionally characterized by ideally smooth and easily renewed surfaces and by the wide, negative → *potential window* for the examination of redox systems. Several types of working electrodes are based on mercury: → *dropping mercury electrode (DME)*, → *hanging mercury drop electrode (HMDE)*, → *static mercury drop electrode (SMDE)*, and → *thin mercury film electrode (TMFE)*. In some applications mercury electrodes are in

fact consisting of liquid amalgam. This happens when a thin mercury film is deposited on a metallic surface (e.g., Ag, Au, Pt) or a hanging mercury drop reservoir is filled with e.g. copper amalgam. Mercury electrodes were used extensively in research and electroanalysis as well as in → *chlor-alkali* electrolysis in the 20th century. Recently, due to problems with handling of liquid mercury and poisonous properties of mercury vapor the use of these electrodes in the laboratories has rapidly decreased.

See also → *electrode materials*, and subentry → *mercury*.

Refs.: [i] Komorsky-Lovrić Š (2002) *Electrodes and electrolytes*. In: Scholz F (ed) *Electroanalytical methods*. Springer, Berlin; [ii] Wrona PK, Galus Z (1982) *Mercury*. In: Bard AJ (ed) *Encyclopedia of electrochemistry of the elements*, vol. IX, part A. Marcel Dekker, New York

ZS

Mercuric and mercurous salts — Salts of Hg(II) and Hg(I), respectively. Soluble mercuric and mercurous salts such as acetates and nitrates are used for the deposition of mercury films on conducting substrates (see → *anodic stripping voltammetry*). Insoluble salts, e.g., chloride and sulfate of Hg(I) in chloride and sulfate medium, respectively, can be used to prepare reference electrodes (see → *calomel electrode*). The formation of insoluble salts of mercury on → *mercury electrodes* determines, among others, the positive limit of their voltammetric potential window.

Ref.: [i] Wrona PK, Galus Z (1982) *Mercury*. In: Bard AJ (ed) *Encyclopedia of electrochemistry of the elements*, vol. IX, part A. Marcel Dekker, New York

ZS

Mercury battery → *Ruben cell*

Mercury cell process → *alkali chloride electrolysis*

Mercury jet electrode → *streaming mercury electrode*

Mercury pool electrode → *electrode materials*, subentry → *mercury*

Mesopores (mesoporosity) → *porous electrodes*

Metals — Chemical elements that are typically lustrous solids at room temperature (except mercury and gallium above 29.78 °C), good electronic and heat → *conductors*. Those of *s*- and *p*-blocks (e.g., sodium, calcium, aluminum) are generally soft silvery reactive elements, and they exist as → *cations* in → *electrolytes*. The transition elements (e.g., copper, iron) are harder

substances and generally less reactive and form coordination complexes. All metals have oxides that are usually basic, although some of those (e.g., aluminum) have amphoteric properties, or even form acids (e.g., CrO_3). Most metallic elements crystallize in one of three simple forms: hexagonally close-packed (hcp) as Be, Cd, Co, Mg, Sc, Ti, Zn; cubic close-packed (ccp) as Ag, Al, Au, Ca, Cu, Ni, Pd, Pb, Pt, Rh, Sr; or less closely packed body-centered cubic (bcc) as Ba, Cs, Cr, Fe, K, Li, Mn, Mo, Rb, Na, Ta, W, V. The properties of the bulk phase is responsible for the \rightarrow conductivity, \rightarrow Fermi level, and the chemical properties, while the differences in atomic level of the surface determine the \rightarrow adsorption and the electrocatalytic activity (\rightarrow electrocatalysis). The structure of the surface of the metals may change, e.g., on the influence of potential-driven oxide formation, dissolution, and redeposition, or chemisorption (surface relaxation, surface reconstruction). Both polycrystalline forms and single crystals are used in electrochemistry as \rightarrow electrode materials.

See \rightarrow charge transport, and \rightarrow semiconductors.

GI

Metal–air battery — Electrochemical energy conversion systems employing a metal anode and an air-fed oxygen-consuming \rightarrow gas diffusion electrode. They may be considered as a special type of \rightarrow fuel cell operating with a special “fuel” or as a \rightarrow primary battery operating with oxygen as \rightarrow depolarizer or positive mass.

RH

Metal deposition — Electrochemical metal deposition is the special case of a \rightarrow redox reaction involving the reduction of a metal cation, Me^{z+} , to the solid metal, Me: Me^{z+} (solution) + $ze^- \rightarrow \text{Me}$ (lattice). This process involves several intermediate steps which can be associated with \rightarrow overpotentials (\rightarrow mass transport overpotential, \rightarrow activation overpotential, \rightarrow crystallization overpotential). The electrons can be supplied by an external power source (\rightarrow electroplating) or by another redox system with a more cathodic Nernst potential (\rightarrow electrodeless plating). Electrochemical metal deposition is a typical surface finishing process for substrates (e.g., \rightarrow corrosion protection, decorative coating). To get well-adhering metal depositions a series of mechanical and chemical pretreatment steps must be applied to the substrate (grinding, polishing, \rightarrow degreasing). In some cases special posttreatment procedures (e.g., conversion coatings in the case of zinc) are used to further improve the properties of the deposit.

Refs.: [i] Budevski E, Staikov G, Lorenz WJ (1996) *Electrochemical phase formation and growth. An introduction to initial stages of metal deposition*. VCH, Weinheim; [ii] Bockris J O'M, Khan SUM (1993) *Surface electrochemistry. A molecular level approach*. Plenum Press, New York

AB

Metal displacement reaction \rightarrow cementation

Metal–metal oxide electrodes — are \rightarrow electrodes of the second kind which can be used for \rightarrow pH measurements. Many metals, e.g., Sb, Bi, W, Mo, Hg, Te, Ag, are covered by a sparingly soluble oxide layer so that the \rightarrow potential of these systems responds to the solution pH as follows: For an electrode $\text{OH}^-|\text{MO}, \text{M}$ with the following equilibrium reactions:

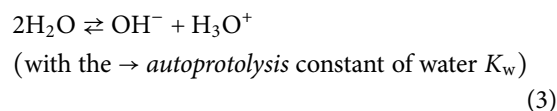
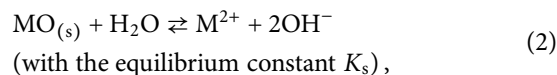
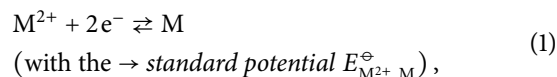

the electrode potential follows as:

$$\begin{aligned} E &= E_{\text{M}^{2+}, \text{M}}^\ominus + (RT/2F) \ln a_{\text{M}^{2+}} \\ &= E_{\text{M}^{2+}, \text{M}}^\ominus + (RT/2F) \ln K_s \\ &\quad - (RT/F) \ln K_w + (RT/F) \ln a_{\text{H}_3\text{O}^+}. \end{aligned}$$

R is the \rightarrow gas constant, T is the absolute temperature, F is the \rightarrow Faraday constant, and $a_{\text{H}_3\text{O}^+}$ is the activity of the hydronium ions.

A similar pH dependence is operative when the metal is covered by a hydroxide layer, or an oxide hydrate layer, provided that the appropriate equilibrium constants are considered. Usually, these electrodes need calibration (the mercury–mercury oxide electrode is an exception and it is a common reference electrode in strongly alkaline systems). Metal–metal oxide electrodes are applicable in a pH range that is limited to low pH values due to the oxide (or hydroxide) dissolution.

Refs.: [i] Galster H (1991) *pH-Measurement: fundamentals, methods, applications, instrumentation*. Wiley-VCH, Weinheim; [ii] Ives DJG, Janz GJ (1961) *Reference electrodes*. Academic Press, New York

HK, FS

Metal oxide gas sensors \rightarrow gas sensors

Methanol — Methanol is the simplest alcohol, of formula CH_3OH ($M_W = 32.042 \text{ g mol}^{-1}$) and is a liquid at room temperature with a melting point of -97°C and a boiling point of 64.7°C . Its vapor pressure is given by $\ln p(\text{mmHg}) = 18.5875 - 3626.55/(T - 34.29)$ in the range -16 to 91°C . At room temperature it is a colorless liquid of density 0.791 g cm^{-3} and viscosity $0.58 \text{ mPa s (mNs m}^{-2}\text{)}$ at 20°C (at other temperatures: $\log_{10} \eta(\text{mNs.m}^{-2}) = 555.3(1/T - 0.003837)$). It is fully miscible with water in all proportions, and other names include methyl alcohol, wood alcohol, and carbinol. Pure methanol was first isolated by Robert Boyle in 1661 and its composition determined by Dumas and Peligot in 1834. In 1923, Matthias Pier, working for BASF, discovered a catalyst for the conversion of synthesis gas (a mixture of CO , CO_2 , and H_2) into methanol, and this is the basis for the modern production of methanol from syngas, which is produced by steam or oxygen reforming of methane through $\text{CH}_4 + \text{H}_2\text{O} \rightarrow \text{CO} + 3\text{H}_2$ and $\text{CH}_4 + \frac{1}{2}\text{O}_2 \rightarrow \text{CO} + 2\text{H}_2$, where the ratio of CO to H_2 can be adjusted to the desired 1:2 ratio by the water-gas shift reaction $\text{CO} + \text{H}_2\text{O} \rightarrow \text{CO}_2 + \text{H}_2$. The CO and H_2 are then reacted over a catalyst mixture of Cu , ZnO and Al_2O_3 developed by ICI at $50\text{--}100 \text{ atm}$ and 250°C : $\text{CO} + 2\text{H}_2 \rightarrow \text{CH}_3\text{OH}$. Methanol can be used directly as a fuel in the internal combustion engine, and in antifreeze mixtures, though its main use at the moment is as a base chemical for conversion to formaldehyde and thence to a range of plastics, plywood, paints, explosives, and textiles. Methanol itself is toxic, mainly because its metabolites, formic acid and formaldehyde cause blindness and death. It can be absorbed through the skin, and it is dangerous to fetal development. The usual fatal dose is about $100\text{--}125 \text{ cm}^3$ in an adult, but toxic effects can take several hours to develop and can be treated using ethanol or 4-methylpyrazole (Formepizole). Both these act by slowing down the action of the enzyme alcohol dehydrogenase, allowing methanol to be excreted without metabolism.

The thermodynamic properties of methanol are as follows: $\text{CH}_3\text{OH (g)}$: $\Delta H^\ominus = -202.2 \text{ kJ mol}^{-1}$, $\Delta G^\ominus = -161.9 \text{ kJ mol}^{-1}$ and $S^\ominus = 238 \text{ J mol}^{-1} \text{ K}^{-1}$; $\text{CH}_3\text{OH (l)}$: $\Delta H^\ominus = -238.64 \text{ kJ mol}^{-1}$, $\Delta G^\ominus = -166.3 \text{ kJ mol}^{-1}$ and $S^\ominus = 127 \text{ J mol}^{-1} \text{ K}^{-1}$; $\text{CH}_3\text{OH (aq)}$: $\Delta H^\ominus = -246 \text{ kJ mol}^{-1}$, $\Delta G^\ominus = -174.5 \text{ kJ mol}^{-1}$ and $S^\ominus = 132.3 \text{ J mol}^{-1} \text{ K}^{-1}$. The E^\ominus value for reduction: $\text{CH}_3\text{OH(aq)} + 2\text{H}^+ + 2\text{e}^- \rightarrow \text{CH}_4 + \text{H}_2\text{O}$ is 0.588 V and for the technologically important reaction $\text{CO}_2 + 6\text{e}^- + 6\text{H}^+ \rightarrow \text{CH}_3\text{OH(aq)} + \text{H}_2\text{O}$, we have $E^\ominus = 0.022 \text{ V}$. This latter is close to the value for hydrogen and suggests that methanol might be able to substitute

for hydrogen in fuel cells, allowing the use of liquid rather than gaseous feed. In fact this \rightarrow *direct methanol fuel cell* has proved difficult to realize: the electrochemical kinetics for the oxidation of methanol are sluggish, with the best catalysts in acid solution being based on platinum/ruthenium mixtures with some tertiary additives. Such catalysts are most effective at higher temperatures, but the current SPE membranes used in these cells (*q.v.*) are not capable of sustaining operation at temperatures much above 80°C . Oxidation of methanol in alkaline solutions is easier, probably because adsorbed CO is more easily attacked by strong nucleophiles such as OH^- than by H_2O or adsorbed Pt-OH or Ru-OH , the dominant species in acidic solutions. However, the oxidation product, CO_2 is strongly soluble in alkali, giving CO_3^{2-} which leads to precipitation of K_2CO_3 or Na_2CO_3 on the electrode surface. It has recently been suggested that OH^- exchange membranes may be more effective in preventing electrode fouling, and new catalysts based on highly divided transition metals have been developed that show promising activity with these membranes.

Refs.: [i] Bard AJ, Parsons R, Jordan J (1985) *Standard potentials in aqueous solution*. Marcel Dekker, New York; [ii] Hamnett A (1999), *Mechanism of methanol electro-oxidation*. In: Wieckowski A (ed) *Interfacial electrochemistry*. Wiley, New York; [iii] Hamnett A (2003) *Direct methanol fuel cells (DMFC)*. In: Vielstich W, Lamm A, Gasteiger H (eds) *Handbook of fuel cells: fundamentals, technology, applications*, vol. 1. Wiley, Chichester, chap 18, pp 305–322

AH

Methylene blue — Methylene blue (MB) is a heterocyclic chemical compound with molecular formula: $\text{C}_{16}\text{H}_{18}\text{ClN}_3\text{S}$, molar mass $M = 319.85 \text{ g mol}^{-1}$; and chemical name: 3,7-bis(Dimethylamino)-phenazathionium chloride, or: Tetramethylthionine chloride; CAS No [61-73-4], m.p. 190°C .

MB belongs to the group of thiazine dyes and is widely used as a redox indicator in analytical chemistry and as a staining dye in biology. In aqueous solutions, which are intensely blue due to the strong light absorbance, MB forms monomers and dimers. The reduced form of MB, called Leuco Methylene blue (LMB), is colorless.

Electrochemical studies indicate that MB adsorbs on Hg , Au , Pt , and other solid electrodes in horizontal orientation with primary interactions with electrode coming from aromatic rings. In contrast to that, on S-modified Au electrodes, well organized MB films with vertical orientation were observed. This is attributed to the formation of disulfide bonds with S adatoms. These

films exhibit fluorescence with $\lambda_{\max,FL} = 660$ nm (compared to 678 nm for monomers and 710 nm for dimers in solution) under laser excitation at $\lambda_{\text{ex}} = 595$ nm. The reduction of MB can be expressed by the equation:

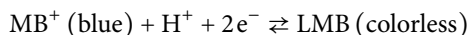

where LMB is neutral. The complex behavior of MB films is due to the involvement of anions in MB films and the formation of different polymorphic phases composed of LMB, cation radical $\text{LMB}^{+\cdot}$, anions, and hydration water. Among anions, particularly strong interactions with F^- ions have been found using EQCN technique.

MB is used as a temporary stain to examine and verify DNA and RNA under a microscope or in a gel. MB is less sensitive as ethidium bromide, but does not intercalate into nucleic acid chains. Recent studies have shown that MB immobilized on metal oxide substrates can mediate NADH catalytic oxidation.

MB can undergo oxidative \rightarrow *electropolymerization* resulting in a poly(methylene blue) film on Au or Pt electrodes. The structure of MB is preserved in PMB, and hence it shows the same catalytic activity, e.g., towards the oxidation of \rightarrow *hemoglobin* as the monomer does.

Refs.: [i] Hepel M, Janusz W (2000) *Electrochim Acta* 45:3785; [ii] Svetlicic V, Zutic V, Clavilier J, Chevalet J (1985) *J Electroanal Chem* 195:307; Zaitseva G, Gushikem Y, Ribeiro ES, Rosatto SS (2002) *Electrochim Acta* 1469; [iii] Kertesz V, Bacskai J, Inzelt G (1996) *Electrochim Acta* 41:2877; [iv] Brett CMA, Inzelt G, Kertesz V (1999) *Anal Chim Acta* 385:119

MHep

Methylene chloride \rightarrow *solvents*

N-Methylformamide \rightarrow *solvents*

Methylisobutyl ketone \rightarrow *solvents*

Micellar electrokinetic chromatography (MEKC) or micellar electrokinetic capillary chromatography (MECC)

— A special case of \rightarrow *electrokinetic chromatography*, in which the secondary phase is a micellar dispersed phase in the capillary.

Ref.: [i] Riekkola ML, Jönsson JÅ, Smith RM (2004) *Pure Appl Chem* 76:443

WK

Michaelis, Leonor



(Jan. 16, 1875, Berlin, Germany – Oct. 9, 1949, New York, USA) German-American chemist. 1908 professor in Berlin, 1922–26 in Nagoya, Japan, 1929–41 in New York, USA. Michaelis has studied redox reactions in living systems [i] and he derived together with Maud Menten an equation describing the rate of enzymatic reactions that became known as Michaelis–Menten equation. Michaelis gave as early as in 1922, a clear description of interfacial potentials (*Phasengrenzpotentiale*) at liquid–liquid interfaces, and he arranged ions according to their lipophilicities, propagating the experimental results and interpretations of \rightarrow *Beutner* [ii].

Refs.: [i] Michaelis L (1933) *Oxydations-Reductions-Potentiale*. Berlin (Engl ed: (1930) *Monographs on experimental biology: oxidation-reduction potentials*. Lippincott, Philadelphia); [ii] Michaelis L (1922) *Die Wasserstoffionenkonzentration*, 2nd edn. Springer, Berlin (Engl edn: (1926) *Hydrogen ion concentration*, vol. 1: *The principles of the theory*. Williams and Wilkins Co, Baltimore)

FS

Michaelis-Menten conditions \rightarrow *Michaelis-Menten kinetics*

Michaelis-Menten kinetics — is the dependence of an initial \rightarrow *reaction rate* upon the concentration of a substrate S that is present in large excess over the concentration of an enzyme or another catalyst (or reagent) E with the appearance of saturation behavior following the Michaelis-Menten equation,

$$v = v_{\max}[\text{S}]/(K_m + [\text{S}]),$$

where v is the observed initial rate, v_{\max} is its limiting value at substrate saturation (i.e., $[\text{S}] \gg K_m$), and K_m is the Michaelis constant, i.e., the substrate concentration at $v = v_{\max}/2$. The definition is experimental, i.e., it applies to any reaction that follows an equation of this general form.

The parameters v_{\max} and K_m of the equation can be determined from the slope and intercept of a linear plot of v^{-1} against $[S]^{-1}$ ("Lineweaver-Burk plot") or from slope and intercept of a linear plot of v against $v/[S]$ ("Eadie-Hofstee plot").

The Michaelis-Menten equation is also applicable if E is present in large excess, in which case the concentration [E] appears in the equation instead of [S].

The term often used to describe reactions that proceed according to the scheme

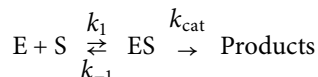

in which case $K_m = (k_{-1} + k_{\text{cat}})/k_1$ ("Briggs-Haldane conditions"). It has mostly been applied only to the special case in which $k_{-1} \gg k_{\text{cat}}$ and $K_m = k_{-1}/k_1 = K_S$; in this case K_m is a true \rightarrow dissociation constant ("Michaelis-Menten conditions").

Ref.: [1] Muller P (1994) *Pure Appl Chem* 66:1077

WK

Micelle — Materials formed of molecules that possess two well-defined regions, one of which is oil-soluble (i.e., hydrophobic) and the other water-soluble (i.e., hydrophilic) are termed amphiphiles, and well-known examples include the fatty acid salts, such as sodium stearate, $\text{CH}_3(\text{CH}_2)_{16}\text{COO}^-\text{Na}^+$, and anionic detergents, such as sodium dodecyl sulfate (SDS), $\text{CH}_3(\text{CH}_2)_{11}\text{OSO}_2^-\text{Na}^+$. In both these cases, the long hydrocarbon chains are hydrophobic and the anionic groups hydrophilic, and all such molecules show strong surfactant behavior, segregating at the surface and lowering the surface tension. At the surface, the molecules adopt a characteristic structure with the hydrocarbon tails protruding into the gas phase but the hydrophilic part remaining immersed in the solution. At low concentrations ($< \sim 10^{-4}$ M), solutions of these amphiphiles behave fairly simply apart from the preferential segregation to the surface, but at higher concentrations, two effects take place: the first is that the surface becomes saturated – a complete monolayer of surfactant forms with the chains all protruding roughly parallel into the gas phase, and secondly the molecules begin to associate strongly in solution, forming micelles as shown schematically in Fig. 1.

The concentration at which micelles first form is the \rightarrow critical micellization concentration or c.m.c.. Initially the micelles formed by SDS and other simple amphiphiles are roughly spherical in shape with a reasonably well-defined number of molecules associating (~ 50

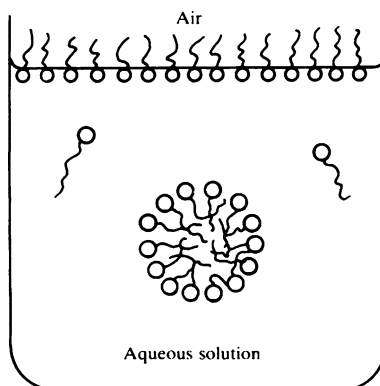

Micelle — Figure 1

in this case). At higher concentrations, well above the first c.m.c., a second c.m.c. may be seen as these spheres become more distorted, forming cylindrical rods, flattened discs, and possibly bilayer membranes and vesicles. A key property of micelles is their ability to solubilize hydrophobic solutes in aqueous solution by incorporating such species into the interior of the micelle. This is the basis of detergent action, but the effect has been exploited in many areas.

Electrochemistry in micellar solutions can take several forms. A key question is whether aggregates form on the electrode surface, as shown in Fig. 2 below; if they do, then electron transfer kinetics to species in solution will depend on whether the species can displace the surfactant or only approach the electrode to within the

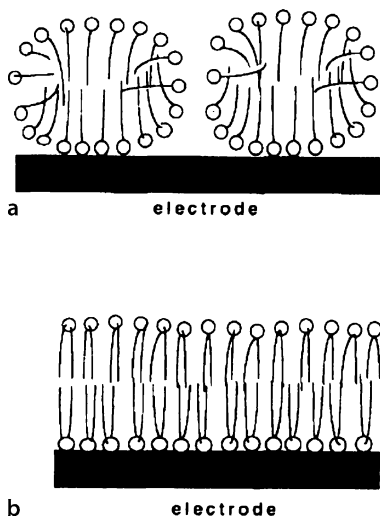

Micelle — Figure 2

diameter of the head group. In the case where the electroactive species is hydrophobic but can be solubilized into the micelle, electron transfer may take place either by the micelle dissociating at the electrode surface, or the micelle may interact with a surfactant aggregate on the electrode, delivering the hydrophobic electroactive species into a local nonaqueous environment as shown in Fig. 3.

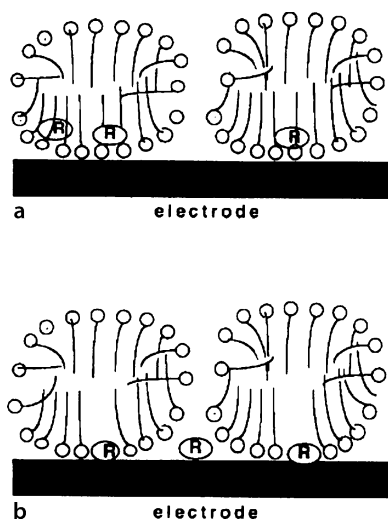

Micelle — Figure 3

A second set of possibilities arises if the electroactive species is adsorbed onto the surface of the micelle; under these circumstances the main effects will be a marked decrease (normally) in apparent diffusion coefficient and again the possibility of inhibited electron transfer due to surface aggregate formation. Finally, the micelle itself may be formed from electroactive surfactant species, and their electrochemistry under controlled hydrodynamic conditions used to explore changes in structure with increasing surfactant or background electrolyte concentrations.

Refs.: [i] Rusling JF (1997) *Colloid Surf* 123:81; [ii] Hunter RJ (1989) *Foundations of colloid science*. Clarendon Press, Oxford, 2 vols

AH

Microcells — A microcell was defined in [i] as an electrochemical cell where at least one distance which limits the electrolyte volume is smaller than 1 mm. A small electrolyte volume can be chosen for different reasons:

- Only parts of the sample are wetted and the microcell enables spatially resolved investigations (\rightarrow *capillary-based microcells*).

- The cell resistance and, thus, the potential drop and the evolution of heat are small.
- The ratio ‘vessel surface’ to ‘electrode volume’ is large, i.e., a good heat emission and an intensive relaxation of intermediates, e.g., radicals. The accumulation of critical amounts of products or educts can be avoided.
- A small cell volume is important for the processing of rare and expensive materials (e.g., enzymes) or for analytical purposes, if only small electrolyte samples are available.
- Processes with common current densities cause detectable changes of the product/educt concentration in the electrolyte (thin film cells).

M

The volume of a real microcell can be defined by different methods:

- By phase boundaries, e.g., walls of solid material (usually insulating materials like glass or plastic, but also metal; this can be true for solid cells like movable masks or capillary based microcells).
- By the interface electrolyte|gas. In some capillary based microcells the droplet volume is defined by the surface tension of the electrolyte and the contact angles.
- By the interface aqueous electrolyte|oil. Electrolyte droplets are sometimes embedded in oil to avoid evaporation of the solvent.

In some cases microcells are parts of macroscopic cells and are defined by diffuse boundaries:

- By hindrance of diffusion, e.g., in the \rightarrow *scanning electrochemical microscope*.
- By the electric field, e.g., with a small counter electrode in a weakly conductive electrolyte.

Typical applications of microcells are:

- Electrochemical microsensors, which measure the concentration of special substances, typically in macroscopic volumes. The microcell is often separated from the environment by a selective barrier, e.g., a membrane.
- Microbatteries which are small devices for energy storage.

- Microcells for surface analysis, e.g., → *capillary-based microcells*.
- Flow-through microcells which are used for pre-concentration of substances (stripping techniques) or to get a fast response if the concentration changes with time. In applications with large current densities the electrolyte flow guarantees the supply of educt or the removal of products.
- Microreactors for electrochemical synthesis.

Refs.: [i] Schultze JW, Osaka T, Datta M (eds) (2002) *New trends in electrochemical technologies series: vol 2. Electrochemical microsystem technologies*. Taylor & Francis, Andover; [ii] Lohrengel MM (1997) *Electrochim Acta* 42:3265

MML

Microelectrode — Electrode with a characteristic dimension ranging from 25 μm to 1 mm. See also → *ultramicroelectrode (UME)*.

CGZ

Microemulsion electrokinetic chromatography (MEEKC) or microemulsion electrokinetic capillary chromatography (MEECC) — A special case of → *electrokinetic chromatography*, where a microemulsion is employed as the dispersed phase.

Ref.: [i] Riekkola ML, Jönsson JÅ, Smith RM (2004) *Pure Appl Chem* 76:443

WK

Microparticles, electrochemistry of → *voltammetry of immobilized microparticles (VIM)*

Micropores (microporosity) → *porous electrodes*

Microscopy, in situ electrochemistry — Several microscopic techniques can be in situ coupled with electrochemistry, as well as electrochemical measurements themselves can be used for producing microscopic images. See → *AFM (atomic force microscopy) in situ electrochemistry*, and → *STM (scanning tunneling microscopy) in situ electrochemistry*. It is also possible to use light microscopy for in situ electrochemical studies, esp. for following electrochemical reactions of immobilized microparticles (→ *voltammetry of immobilized microparticles* [i]). The microscopy can be further combined with diffuse reflection spectroscopy [ii]. In → *scanning electrochemical microscopy* electrochemical measurements at → *ultramicroelectrodes* are used to produce microscopic images of surfaces.

Refs.: [i] Schröder U, Meyer B, Scholz F (1996) *Fresenius' J Anal Chem* 356:295; [ii] Schröder U, Scholz F (1997) *J Solid State Electrochem* 1:62

FS

Microwaves — Electromagnetic radiation in the frequency range 0.5 to 500 GHz (corresponding to wavelengths from 0.6 m to 0.6 mm) is commonly known as microwave radiation and situated between radio-wave and terahertz radiation in the electromagnetic spectrum [i]. This frequency domain is associated with the rotation and rotational transition for many molecules and therefore microwave spectroscopy is employed in the measurement of molecular properties. The domestic microwave frequency, 2.45 GHz, is close to the rotational excitation of liquid water (at ca. 20 GHz at room temperature) and therefore used to thermally excite or heat water (and other solvent media) [ii]. In electrochemistry microwaves can be self-focused into the solution phase at the tip of the electrode to provide strong localized heating and jet-boiling effects [iii].

Refs.: [i] Kingston HM, Haswell SJ (1997) *Microwave-enhanced chemistry*. American Chemical Society, Washington; [ii] Loupy A (2002) *Microwaves in organic synthesis*. Wiley-VCH, New York; [iii] Marken F, Sur UK, Coles BA, Compton RG (2006) *Electrochim Acta* 51:2195

FM

Mid-peak potential in cyclic voltammetry → *potential, subentry* → *mid-peak potential in cyclic voltammetry*

Migration — A kind of → *charge transport* that is related to ions and the existence of potential gradient in the solution. When current flows through a solution it is carried by ions and this constitutes the migrational transport. To limit migrational transport of the ions that are components of the redox system examined in the cell, excess → *supporting electrolyte* is added to the solution. A 100-excess supporting electrolyte means that the contribution of examined ions to the migrational transport is smaller than 1%. Then it can be assumed that the transport of the examined species to the → *working electrode* surface is of diffusional character only. This simplifies the theoretical description of the current. Migration of the electroactive species can either enhance (e.g., during the reduction of cations) or diminish (e.g., during the oxidation of cations) the current flowing at the electrode. Measuring the currents under mixed migration-diffusion conditions may be advantageous in particular electrochemical and electroanalytical situations. Uncharged molecules do not migrate.

Ref.: [i] Bard AJ, Faulkner LR (2001) *Electrochemical methods, 2nd edn* Wiley, New York

ZS

Migration time, t_m — In \rightarrow *capillary electromigration techniques*, the time required for the analyte to move through the effective length of the capillary, L_{eff} , that is, from the sample introduction point to the detection point.

Ref.: [i] Riekkola ML, Jönsson JÅ, Smith RM (2004) *Pure Appl Chem* 76:443

WK

Migration time of micelles (in micellar electrokinetic chromatography), t_{mc} — Experimentally determined as the \rightarrow *migration time* of a compound that is completely retained in the micellar phase.

Ref.: [i] Riekkola ML, Jönsson JÅ, Smith RM (2004) *Pure Appl Chem* 76:443

WK

Minerals, electrochemistry of — Many minerals, esp. the ore minerals (e.g., metal sulfides, oxides, selenides, arsenides) are either metallic conductors or semiconductors. Because of this they are prone to undergo electrochemical reactions at solid solution interfaces, and many industrially important processes, e.g., mineral leaching and flotation involve electrochemical steps [i–ii]. Electrochemical techniques can be also used in quantitative mineral analysis and phase identification [iii]. Generally, the surface of minerals (and also of glasses) when in contact with solutions can be charged due to ion-transfer processes. Thus mineral surfaces also have a specific \rightarrow *point of zero charge* depending on their surface chemistry [iv].

Refs.: [i] Woods R (1981) *Mineral flotation*. In: Bockris JO'M, Conway BE, Yeager E, White RE (eds) *Comprehensive treatise of electrochemistry*, vol. 2. Plenum Press, New York, pp 571; [ii] Doyle FM, Kelsal GHL, Woods R (eds) (2003) *Electrochemistry in mineral and metal processing VI (Proceedings of the 6th International Symposium, From the 203rd Meeting of The Electrochemical Society, Paris, France, April 27–May 2, 2003, ECS Proceedings, vol. 2003-18)*. ECS, Pennington; [iii] Scholz F, Schröder U, Gulaboski R (2005) *Electrochemistry of immobilized particles and droplets*. Springer, Berlin; [iv] Brady PV (ed) (1996) *Physics and chemistry of mineral surfaces*. CRC Press, Boca Raton

FS

Minotto cell — This was a variant of the \rightarrow *Daniell cell*. See also \rightarrow *zinc*, \rightarrow *Zn²⁺/Zn electrodes*, \rightarrow *Zn²⁺/Zn(Hg) electrodes*, \rightarrow *Zinc-air batteries (cell)*, and \rightarrow *Leclanché cell*.

Ref.: [i] Hauck WP (1883) *Die Galvanischen Batterien, Accumulatoren und Thermosäulen*, 2nd edn. Hartleben's Verlag, Wien

FS

Mirage effect — The deflection of a probe light beam based on the refraction property. When a light beam

crosses a transparent medium with an inhomogeneous index of refraction, it deviates from its initial trajectory in the direction of the increasing index [i]. The dependence of the deviation angle (θ) of the light beam on the gradient of refractive index is given by: $\theta = (L/n)(\delta n/\delta x)$. L is the interaction length between the beam and the zone of perturbed index, n the \rightarrow *refractive index* of the unperturbed medium, and x the axis along which the perturbation evolves. Under isobaric conditions, the \rightarrow *refractive index* depends on the temperature (T) and on the concentration (C) of dissolved species [ii]. Thus, the derivation of n with respect to x results in: $\delta n/\delta x = (\partial n/\partial T)(\delta T/\delta x) + (\partial n/\partial C)(\delta C/\delta x)$.

The term mirage effect has been indistinctly assigned to studies performed by \rightarrow *photothermal deflection spectroscopy (PDS)* and \rightarrow *probe beam deflection (PBD)*. However, PDS is based on the analysis of the first term of the last equation, whilst in PBD, essentially the second term is evaluated.

Refs.: [i] Barbero CA (2005) *Phys Chem Chem Phys* 7:1885; [ii] Bidoia ED (2005) *Chem Phys Lett* 408:1

FG

Mirror galvanometer (reflecting galvanometer) \rightarrow *Ampereometer* where instead of a moving needle, a small mirror is placed on a turning metal wire. The mirror directs a light beam to a scale where the deflection of the beam can be read. The first mirror galvanometer was invented by \rightarrow *Poggendorff* in 1826. A mirror galvanometer was used in the first \rightarrow *polarograph* to measure the current.

Ref.: <http://physics.kenyon.edu/EarlyApparatus/>

FS

Mixed electrode \rightarrow *electrode*

Mixed ionic–electronic conductor \rightarrow *conductor*

Mixed potential \rightarrow *potential*

Mixing entropy — An important result that can be derived directly from the \rightarrow *Boltzmann* equation for entropy is the value of the \rightarrow *entropy* of mixing: if we consider a simple lattice with $N_A + N_B$ points occupied by N_A molecules of A and N_B molecules of B, then in the absence of mixing there is only one arrangement, assuming that the molecules of A are all indistinguishable, and making a similar assumption about B. However, A and B molecules are clearly distinguishable, and if we allow free mixing on the lattice, then it is easy to see that $\Omega_{\text{mix}} = \frac{(N_A + N_B)!}{N_A! N_B!}$ (Ω_{mix} is the number of possible arrangements of the molecules A and B, bearing in mind that all A are

identical to one another, and likewise all B). The entropy change on mixing, assuming that the mixing is indeed random, which will be satisfied provided there are no large differences between intermolecular forces and no large differences in molecular size, is $\Delta S_{\text{mix}} = k \ln(\Omega_{\text{mix}}/1) = -k \left(N_A \ln \frac{N_A}{N_A+N_B} + N_B \ln \frac{N_B}{N_A+N_B} \right)$, and from this expression the chemical potential for the components of an ideal solution may be derived. If we make the assumption that the heat of mixing is not zero but that the entropy of mixing is still given by the configuration term above, then we recover the theory of regular solutions. In this case, if w_{AB} , w_A and w_B are the intermolecular interactions of A and B molecules, A–A molecules and B–B molecules respectively, it is straightforward to show that $\Delta_{\text{mix}}H = zw \left(\frac{N_A N_B}{N_A + N_B} \right)$, where z is the mean number of next-nearest neighbors, and $2w = 2w_{AB} - w_{AA} - w_{BB}$. From this and the expression for the configurational or mixing entropy above:

$$\Delta G_{\text{mix}} = zw \left(\frac{N_A N_B}{N_A + N_B} \right) + kT \left(N_A \ln \frac{N_A}{N_A + N_B} + N_B \ln \frac{N_B}{N_A + N_B} \right)$$

this leads to the following expressions for the activity coefficients: $\ln \gamma_A = z \frac{Lw}{RT} x_B^2$ and $\ln \gamma_B = z \frac{Lw}{RT} x_A^2$, where L is the Avogadro constant (here the symbol L is used for the Avogadro constant to avoid confusion with N_A).

The entropy of mixing has important consequences not only for the simple theories of mixing but also in such areas as solid-solutions where a mixture of two species with a single electroactive common ion can show considerable deviations from the expected linear behavior of formal potential with composition, a result highlighted by Heusler.

Refs.: [i] Denbigh KG (1987) *Principles of chemical equilibrium*, 4th edn. Cambridge University Press, Cambridge; [ii] Heusler KE (1996) *Electrochim Acta* 41:411

AH

Mobility — The (ionic or electric) mobility u of an ion is given by the drift velocity v (the velocity of an ion at equilibrium between the accelerating effect of the electric field and the decelerating effect of the viscous medium (Stokes friction)) of an ion and the effective electric field E

$$u = \frac{v}{E}$$

A larger mobility of an ion results at the same electric field in a greater drift velocity. Typical velocities are around $6 \times 10^{-8} \text{ m}^2 \text{ s}^{-1} \text{ V}^{-1}$. Only values for protons

and hydroxyl ions are larger because their movement is not actually a movement of these species (\rightarrow Grotthuss mechanism).

RH

Möbius cell — Cell design employed in electrochemical silver purification (\rightarrow *electrorefining*). Silver of low purity is used as anode, an aqueous solution of silver nitrate (and added NaNO_3) serves as electrolyte solution, the cathodically deposited silver is of higher purity. Metallic impurities less noble than silver will not be deposited at the cathode potential, more noble metals will drop off the anode but will not be dissolved; they form the anode sludge. Unfortunately silver is deposited in dendritic form (\rightarrow *dendrite growth*). In order to avoid short-circuiting between anode and cathode a fairly large electrode distance (about 7 cm) has to be maintained, in addition the dendritic deposit has to be removed periodically. In the Möbius cell design this is accomplished by wiping the deposit of the cathode from time to time. Contamination of the silver deposit falling down to the cell bottom by the anode sludge is avoided by encapsulating the anode in a porous woven bag. Purities of 99.99% can be obtained in a single electrolysis, further purification up to 99.999% can be achieved by repeating the process. As compared to the \rightarrow *Balbach-Thum cell* the incomplete dissolution of the anode (a stump always remains), the handling of several anodes connected in parallel, the moving parts of the scraper may be taken into account. The small cell size and electrolyte solution volume, the lower cell voltage, and higher current density may be seen as advantage.

Refs.: [i] Zirngiebl E (1993) *Einführung in die Angewandte Elektrochemie*. Salle & Sauerländer, Frankfurt; [ii] Pletcher D, Walsh FC (1993) *Industrial electrochemistry*. Blackie Academic & Professional, London

RH

Modified Born equation \rightarrow *Born equation*

Modified Verwey–Niessen model (MVN model) \rightarrow *Verwey–Niessen model*

Module of impedance \rightarrow *impedance*

MOG (Metal oxide gas sensors) \rightarrow *gas sensors*

Moiety — is generally used to signify part of a molecule, e.g., in an ester R^1COOR^2 the alcohol moiety is R^2O . The term should not be used for a small fragment of a molecule.

Ref.: [i] Muller P (1994) *Pure Appl Chem* 66:1077

WK

Moissan, Ferdinand Frédéric Henri



(© The Nobel Foundation)

(Sep. 28, 1852, Paris, France – Feb. 20, 1907, Paris, France) Moissan studied chemistry and pharmacy at the Musée d'Histoire Naturelle, Paris. In 1880 he received his Ph.D. for work in inorganic chemistry. After 1886 he was professor of toxicology at the Ecole Supérieure de Pharmacie, and after 1899 he held the chair of inorganic chemistry. In 1900 he became professor of inorganic chemistry at the Sorbonne. Moissan was the first person to synthesize elementary fluorine, by \rightarrow *electrolysis* of KF dissolved in liquid anhydrous HF in a platinum cell at low temperature ($-23\text{ }^\circ\text{C}$). With that experiment he proved that electrolysis was capable of oxidizing species such as fluoride ions, for which no chemical oxidant was strong enough. Moissan received the Nobel Prize in Chemistry in 1906 for the synthesis of fluorine and for the development of the electric arc furnace. He also discovered carborundum. Electrolysis is still used today to produce fluorine on an industrial scale; however, KF is now electrolyzed as a molten salt at $250\text{ }^\circ\text{C}$, or molten KH_2F_3 is used at $50\text{ }^\circ\text{C}$ (see also \rightarrow *Fredenhagen*).

Refs.: [i] <http://nobelprize.org/index.html>; [ii] Tressaud A (2006) *Angew Chem Int Ed* 45:6792

FS

Molar conductivity \rightarrow *conductivity*

Molar electrochemical Peltier heat (II) — accounts for the amount of heat absorbed or released when an electrochemical reaction takes place under isothermal and reversible conditions and one mol of electric charge or ions is transferred from one phase to another. The molar electrochemical Peltier heat Π comprises two contributions; one comes directly from the entropy of the reaction taking place at the electrode and another is provided by the movement of ions in solution by migration (\rightarrow *transport entropy* S^* or \rightarrow *Eastman's entropy*). By convention the molar electrochemical Peltier heat is considered positive for an exothermic anodic reaction. For

a general oxidation–reduction reaction, the molar electrochemical Peltier heat can be written in terms of the entropy as follows [i]:

$$\begin{aligned} \{\text{Ox}\} + z e^- &\rightleftharpoons \{\text{Red}\} \\ \Pi = \Pi_{\text{Ox}} &= -T (\Delta S_{\text{Ox}} + \Delta S^*) = -\Pi_{\text{Red}} \\ &= T (\Delta S_{\text{Red}} - \Delta S^*) \end{aligned}$$

where

$$\begin{aligned} \Delta S_{\text{Ox}} &= S_{\text{Ox}} - S_{\text{Red}} + z S_e \\ S_i &= S_i^0 - R \ln a_i - RT \frac{d \ln a_i}{dT} \end{aligned}$$

the subscript i refers to the species that participate in the reaction and the molar entropies. On the other hand, the transport entropy is given by:

$$\Delta S^* = z \left(\sum \frac{t_j S_j^*}{z_j} + S_e^* \right)$$

where j denotes all the ionic species migrating in the electric field, t_j and z_j are the ion transport number and the ion charge, respectively, S_j^* corresponds to the \rightarrow *Eastman's entropy* for the ion under consideration. The relationship between the electrochemical Peltier heat (Π) and the Peltier coefficient π is given by the following expression:

$$\Pi = \pi \cdot z \cdot F$$

where F is the \rightarrow *Faraday constant*.

Refs.: [i] Boudeville P (1994) *Inorganic Chim Acta* 226:69; [ii] Newman J, Thomas-Alyea KE (2004) *Electrochemical systems*, 3rd edn. Wiley-Interscience, Hoboken, pp 317

MBS

Molar ionic conductivity — This quantity, first introduced by \rightarrow *Kohlrausch*, is defined by $\lambda_i \equiv |z_i| F u_i$ (SI unit: $\text{S m}^2 \text{ mol}^{-1}$), where z_i and u_i are the charge number and \rightarrow *ionic mobility* of an ion, respectively. The molar \rightarrow *conductivity* of an electrolyte $\text{M}_{\nu_+} \text{X}_{\nu_-}$ (denoted by Λ) is given by $\Lambda = \nu_+ \lambda_+ + \nu_- \lambda_-$, where λ_+ and λ_- are the molar ionic conductivities of the cation and anion. The λ_i value of an ion at infinite dilution (denoted by λ_i^∞) is specific to the ion. For alkali metal ions and halide ions, their λ_i^∞ values in water decrease in the orders: $\text{K}^+ > \text{Na}^+ > \text{Li}^+$ and $\text{Br}^- > \text{Cl}^- > \text{F}^-$. These orders are in conflict with those expected from the crystal ionic radii, because the smaller ions are more highly hydrated, so that the \rightarrow *hydrated ions* become larger and thus less mobile. Based on Stokes' law, the radius of a hydrated ion

(r_s) can be estimated from λ_i^∞ by $r_s = |z_i|e/(6\pi\eta u_i^\infty)$ with $u_i^\infty = \lambda_i^\infty/(|z_i|F)$, where η is the dynamic \rightarrow viscosity of water. It is also known that the λ_i^∞ value of hydronium ion (H_3O^+) is much larger than those of other ions (about seven times larger than for Na^+). This phenomenon can be elucidated in terms of the proton jump mechanism, the so-called \rightarrow Grotthuss mechanism.

Refs.: [i] Marcus Y (1985) *Ion solvation*. Wiley, Chichester; [ii] Marcus Y (1997) *Ion properties*. Marcel Dekker, New York

Molar polarization \rightarrow Debye–Clausius–Mossotti equation

M

Molecular entity — is any constitutionally or isotopically distinct atom, molecule, ion, \rightarrow ion pair, \rightarrow radical, conformer etc., identifiable as a separately distinguishable entity. Molecular entity is used as a general term for singular entities, irrespective of their nature, while \rightarrow chemical species stands for sets or ensembles of molecular entities. The name of a compound may refer to the respective molecular entity or to the chemical species, e.g., methane may mean a single molecule of CH_4 (molecular entity) or a molar amount, specified or not (chemical species), participating in a reaction. The degree of precision necessary to describe a molecular entity depends on the context. For example, “hydrogen molecule” is an adequate definition of a certain molecular entity for some purposes, whereas for others it is necessary to distinguish the electronic state and/or vibrational state, and/or nuclear spin, etc. of the hydrogen molecule.

Ref.: [i] Muller P (1994) *Pure Appl Chem* 66:1077

WK

Molecular metals — A large group of molecular compounds which possess metal-like electronic conductivities (\rightarrow metals) in the solid state (sometimes even superconductivity at low temperatures). Among these compounds are salts consisting of anions and cations that form \rightarrow charge-transfer complexes (conducting salts). Most prominent are the conducting salts derived from tetracyanoquinodimethane (\rightarrow tetracyanoquinodimethane electrodes [i]), however, also various transition metal complexes possess such properties [ii]. Another group of molecular metals are the \rightarrow fullerenes [iii, iv]. Molecular metals are used in electrochemistry as electrodes or to modify the surface of electrodes for the purpose of achieving desirable electrocatalytic properties (\rightarrow electrocatalysis). See also \rightarrow tetrathiafulvalene electrodes. The \rightarrow conducting poly-

mers are distinguished from molecular metals by possessing a covalent network of bonds that keeps the polymer together, whereas the molecular metals possess discernable \rightarrow molecular entities, i.e., here charge-transfer complexes, that build up the solid lattice.

Refs.: [i] Oguro F, Otsubo T (1997) *Conducting hetero-TCNQs*. In: Nalwa HS (ed) *Organic conducting molecules and polymers*, vol. 1. Wiley, Chichester, pp 229; [ii] Kobayashi A, Kobayashi H (1997) *Molecular metals and superconductors based on transition metal complexes*. In: Nalwa HS (ed) *Organic conducting molecules and polymers*, vol. 1. Wiley, Chichester, pp 249; [iii] Tanigaki K (1997) *Conductivity and superconductivity in doped fullerenes*. In: Nalwa HS (ed) *Organic conducting molecules and polymers*, vol. 1. Wiley, Chichester, pp 293; [iv] Chlístunoff J, Cliffl D, Bard AJ (1997) *Electrochemistry of fullerenes*. In: Nalwa HS (ed) *Organic conducting molecules and polymers*, vol. 1. Wiley, Chichester, pp 333

FS

Molecular sieving range (molecular porosity) \rightarrow porous electrodes

Molten carbonate fuel cell — Fuel cells are classified primarily by the kind of electrolyte they employ. The type of electrolyte used in \rightarrow fuel cells relates to the kind of chemical reactions that take place in the cell, the kind of catalysts required, the temperature range in which the cell operates, the fuel required, and other factors. These characteristics, in turn, affect the applications for which these cells are most suitable. The molten carbonate cell is a high-temperature device. The high rates of reactions at high temperature enable the use of the catalysts and allow one to conduct electrochemical reactions at relatively low \rightarrow overpotentials. As a result molten carbonate fuel cells can reach efficiencies approaching 60 percent, considerably higher than the 37–42 percent efficiencies of phosphoric acid fuel cells. When the waste heat is well managed and used, overall fuel efficiencies can be as high as 85 percent. Currently, demonstration units have produced up to 2 megawatts (MW), but designs exist for units of 50 to 100 MW capacity. Molten carbonate fuel cells (MCFCs) are currently being developed for natural gas and coal-based power plants for electrical utility, industrial, and military applications. MCFCs use an electrolyte composed of a molten carbonate salt mixture suspended in a porous, chemically inert ceramic lithium aluminum oxide (LiAlO_2) matrix. Since they operate at 650 °C and above, nonprecious metals can be used as catalysts at the anode and cathode, reducing costs. At such temperatures the salts melt and conduct carbonate ions (CO_3^{2-}) from the cathode to the anode. The electrochemical reactions occurring in these cell are:

- at the anode: $\text{H}_2 + \text{CO}_3^{2-} \rightleftharpoons \text{H}_2\text{O} + \text{CO}_2 + 2\text{e}^-$
- at the cathode: $\frac{1}{2}\text{O}_2 + \text{CO}_2 + 2\text{e}^- \rightleftharpoons \text{CO}_3^{2-}$

with the overall cell reaction:

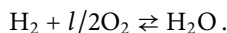

Note that CO, when presents is not directly used by the electrochemical oxidation, but rather produces additional H_2 by the water gas shift reaction: $\text{CO} + \text{H}_2\text{O} \rightleftharpoons \text{H}_2 + \text{CO}_2$. A fuel such as natural gas can also be used in MCFCs. However, it has to be processed either externally or within the cell in the presence of a suitable catalyst to form H_2 and CO by the reaction: $\text{CH}_4 + \text{H}_2\text{O} \rightleftharpoons 3\text{H}_2 + \text{CO}$ (and when $\text{CO} + \text{H}_2\text{O} \rightarrow \text{H}_2 + \text{CO}_2$).

The scheme of MCFC is presented below:

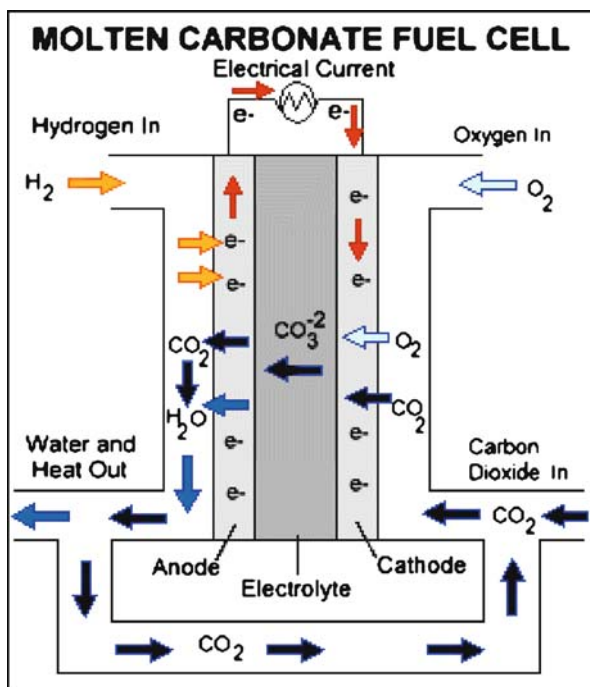

Molten carbonate fuel cell — Figure

Refs.: [i] Bischoff M (2006) *J Power Sources* 154(2):461; [ii] Wijayas-inghe A, Bergman B, Lagergren C (2006) *Solid State Ionics* 177(1–2):165; [iii] Durante G, Vegni S, Capobianco P, et al (2005) *J Power Sources* 152(1):204; [iv] Heidebrecht P, Sundmacher KD (2005) *J Electrochem Soc* 152(II):A2217; [v] Dicks AL (2004) *Solid State Mater Sci* 8(5):379

DA, MK

Monocrystal — A single crystal that is as perfect as possible. Monocrystals can be obtained under strictly controlled crystallization conditions, using, e.g., the Czochralski technique. In electrochemical investigation

at single-crystal surfaces a breakthrough was achieved when Clavilier et al. showed that small single-crystal platinum surfaces could be prepared simply with high temperature flame treatment in an oxygen–hydrogen burner by melting and recrystallization of metal [i]. A similar technique of heat treatment, called flame annealing, appeared to work well also with gold and silver (for more details and other approaches see [ii]). Electrochemical measurements with distinct faces of monocrystals allow a deeper insight into the electrochemistry on polycrystalline electrodes, because it is possible to determine which electrochemical signal arises on which crystal face. Further, the effect of crystal structure on the kinetics and the thermodynamics of electrode reactions could be elucidated [iii]. Scanning tunneling microscopy (STM) and atomic force microscopy (AFM) (\rightarrow *AFM in situ electrochemistry*, \rightarrow *scanning probe microscopy (SPM)*, \rightarrow *STM, in-situ electrochemistry*) allowed in situ studies of the orientation of the adsorbed molecules and ions on single faces of monocrystals.

Refs.: [i] Clavilier J, Faure R, Guinet G, Durand R (1980) *J Electroanal Chem* 107:205; [ii] Kolb DM (2001) *Angew Chem Int Ed* 40:1162; [iii] Hubbard AT (1988) *Chem Rev* 88:633

MD

Monolayer — is a single, closely packed layer of atoms or molecules. Monolayers can be formed only on interfaces of two contacting phases. In electrochemistry the phenomenon of monolayer formation at electrode surfaces is most important. In this case monolayers of substances are formed at electroconductive faces by physical interaction (\rightarrow *adsorption*) or at least partially chemical reaction (\rightarrow *chemisorption*). Monolayers of atoms can be formed at electrode surfaces in processes of \rightarrow *underpotential deposition*. In special cases, when a particular part of the adsorbed molecule interacts strongly with the substrate and the monolayer has a strongly ordered structure, a \rightarrow *self-assembled monolayer* is formed. Monolayers formed at interfaces usually significantly modify their properties. They usually strongly affect the electrode processes, the electron transfer rate (both \rightarrow *electrocatalysis* and \rightarrow *inhibition* are possible), or even the mechanism of the electrode reaction. See also \rightarrow *Langmuir–Blodgett films*.

Ref.: [i] Adamson AW, Gast AP (1997) *Physical chemistry of surfaces*, 6th edn. Wiley-Interscience; [ii] Wieckowski A (ed) (1999) *Interfacial electrochemistry. Theory, experiment, and application*. Marcel Dekker, New York; [iii] Dynarowicz-Latka P, Dhananabalan A, Oliveira Jr ON (2001) *Adv Colloid Interface Sci* 91:221

MD

MOS (metal oxide sensors) → *gas sensors*

Mössbauer spectroscopy → *spectroscopy*, → *radiochemical (nuclear) methods in electrochemistry*

Mott, Nevill Francis



M

(Sep. 30, 1905, Leeds, England – August 08, 1996, Milton Keynes, England) Mott was the first child of Charles Francis Mott and Lilian Mary Reynolds, both of whom worked at the Cavendish Laboratory under J. J. Thomson (1856–1940), the discoverer of the → *electron*. In 1927 Mott graduated BA from St. John's College, Cambridge. After spending part of 1928 in Copenhagen with Niels Bohr (1885–1962), he was appointed lecturer at Manchester University in 1929. In 1930, Mott returned to Cambridge, received a master's degree, and became a lecturer at the college of Gonville and Caius (pronounced *kees*). In 1933 he moved to Bristol University. After a period of military research in London during WWII, he became Director of the Henry Herbert Wills Physical Laboratory at Bristol. In 1954 he was appointed Cavendish Professor of Physics at Cambridge, a post he held until 1971. During the period 1929–33 he applied the “new” quantum mechanics to electron scattering. In particular, he was interested in the case where a high-energy electron is passing by an atom, and is deflected by its electric field. During such a process the electron is often decelerated, causing it to emit a type of radiation called “bremsstrahlung”. When quantum effects dominate over classical coulombic effects, this interaction is now referred to as “Mott Scattering”. After his move to Bristol, Mott decided to investigate the behavior of electrons in solids. Over a decade, he gradually built up a store of knowledge, and eventually collaborated with → *Gurney* to create the classic solid-state textbook “Electronic Processes in Ionic Crystals” [i]. Together, they also formulated a theory explaining the effect of light on photographic emulsions (the theory of the latent image). By the mid-1940s he had turned his attention to doped magnetic oxides, which were puzzling everyone because they

should have been conducting, but weren't. These materials are now known as “Mott Insulators”, in recognition of his remarkable discovery that, for partially filled bands, electron–electron correlations tend to localize the electrons and thus drive the whole system into an insulating state [ii]. Finally, in the mid-1960s, Mott switched his attention to noncrystalline, or amorphous, semiconductors, a research shift that brought him the Nobel Prize in 1977 (together with P. W. Anderson and J. H. van Vleck). Once again Mott focused on the interaction between the motions of electrons and the motions of atomic nuclei, but this time at low energies where localized electronic states are formed. Mott and his contemporaries realized that in any noncrystalline material the states at the bottom of the → *conduction band* were localized (that is to say, they were actually electron traps) and that there was a distribution of such traps as a function of energy, up to a certain “mobility edge” [iii]. Most importantly, the existence of a mobility edge implied two different mechanisms of conduction, which were soon found by experimentalists. At high temperature, the electrons had enough energy to become delocalized above the mobility edge, and thus conducted normally, whereas at low temperature the electrons remained localized below the mobility edge, and could move only by “hopping” (tunneling) between the localized states. This overall picture, which Mott helped to develop, is widely applied today in such diverse areas as computer memory, photocopying machines, and the theory of → *conducting polymers*. Mott's ideas on noncrystalline materials are beautifully summarized in his book with Edward Arthur Davis (b. 1936) published in 1979 [iv].

Refs.: [i] Mott NF, Gurney RW (1948) *Electronic processes in ionic crystals*. Clarendon Press, Oxford; [ii] Mott NF (1949) *Proc Phys Soc London A62:416*; [iii] Mott NF (reprinted 1992) *Electrons in glass*. In: Lundqvist S (ed) *Nobel lectures, physics 1971–1980*. World Scientific Publishing Co., Singapore; [iv] Mott NF, Davis EA (1979) *Electronic processes in non-crystalline materials*. Clarendon Press, Oxford

SF

Mott–Schottky equation → *Mott–Schottky plot*

Mott–Schottky plot — is a graphical representation of the relationship between the → *space charge layer* → *capacitance*, and the → *potential* of a semiconducting → *electrode* (Mott–Schottky equation):

$$\frac{1}{C^2} = \frac{2}{\epsilon\epsilon_0 e N_D} \left(E - E_{fb} - \frac{kT}{e} \right)$$

where E_{fb} is the flatband potential, and N_D is the → *doping density*. This relationship results from pinning of the

energy band edges at the \rightarrow surface (see also \rightarrow semiconductor), and can be used for an ideally polarizable semiconductor/electrolyte \rightarrow interface. Analysis of Mott-Schottky plots is a standard approach for electrochemical characterization of semiconductors and films on metal surface [i]. In particular, the doping density and flat-band potential can be determined from slope of the straight line and from intercept, respectively (Figure). The major limitations are related to the appearance of faradaic processes and surface states affecting the density of electronic \rightarrow charge carriers.

See also \rightarrow band-bending at semiconductor-solution interface.

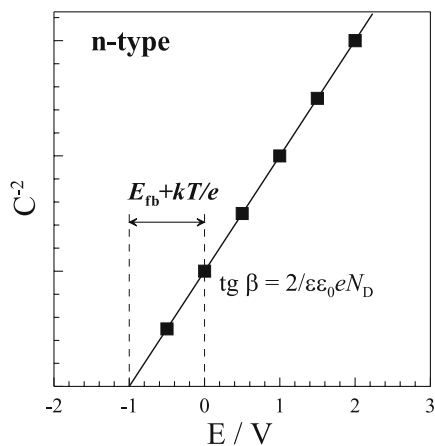

Mott-Schottky plot — Figure. Determination of the doping density and flat-band potential from the Mott-Schottky plot of an n-type semiconductor

Refs.: [i] Morrison SR (1980) *Electrochemistry at semiconductor and oxidized metal electrodes*. Plenum Press, New York; [ii] IUPAC Commission on Electrochemistry (1991) *Pure Appl Chem* 63:569

Moving boundary electrophoresis \rightarrow isotachopheresis

Muirhead pile — Assembly of \rightarrow Daniell cells. See also \rightarrow zinc, \rightarrow Zn²⁺/Zn electrodes, \rightarrow Zn²⁺/Zn(Hg) electrodes, \rightarrow Zinc-air batteries (cell), and \rightarrow Leclanché cell.

Ref.: [i] Hauck WP (1883) *Die Galvanischen Batterien, Accumulatoren und Thermosäulen*, 2nd edn. Hartleben's Verlag, Wien

Müller, Erich



(Universitätsarchiv der TU Dresden, Fotoarchiv)

(Feb. 17, 1870, Chemnitz, Germany – Nov. 20, 1948, Dresden, Germany) Müller studied in Strassburg and Berlin, where he also obtained his doctorate in 1895. From 1895–98 he worked as a chemist in dye factories in Germany and England, and he returned in 1898 to Dresden where he worked as assistant of \rightarrow Foerster. Müller habilitated in 1901 and became extraordinary professor in 1903. In the following years he moved to Braunschweig and Stuttgart, and in 1912 he became professor in Dresden where he worked until his retirement in 1935. Müller contributed to \rightarrow electroanalysis, especially popularizing \rightarrow potentiometric titrations [i–iii].

Refs.: [i] Herzog K, Hegewald H (2002) *Analytische Chemie in Dresden im Wandel der Zeit*. TU Dresden; [ii] *Professorenkatalog Universität Dresden*; [iii] Müller E (1912) *Elektrochemisches Praktikum*. Steinkopff, Dresden (8th edn, 1950); [iv] Müller E (1921) *Elektrochemische Maßanalyse*. Steinkopff, Dresden

FS

Multielectron transfer reactions at the interface of dielectric media — Vectorial charge transfer at the interface between two dielectric media is an important stage in many electrochemical and bioelectrochemical processes such as those mediated by energy-transducing membranes. Many biochemical redox reactions take place at aqueous medium/membrane interfaces, and some of these reactions are multielectron processes. Since multielectron reactions do not pollute the environment with toxic intermediates and are ecologically safe, they are used by nature for biochemical energy conversion during respiration and photosynthesis. An important parameter in the quantum theory of charge transfer in polar media is the medium reorganization energy E_s that determines activation energy. Reagents and products can be represented by a set of N spherical centers arbitrarily distributed in a polar medium. The charges of each of the reaction centers in the initial and final state

VK

FS

are z^i and z^f , respectively. Taking R_k to represent coordinates of the centers and ε_i for dielectric constants of the reagents, it follows that energy of reorganization E_s is equal to

$$E_s = 0.8 \left(\frac{1}{\varepsilon_{opt}} - \frac{1}{\varepsilon_{st}} \right) \times \left\{ \sum_{p=1}^N \left[\frac{(\delta z_k)^2}{2a_p} + \sum_{\substack{k=1 \\ k \neq p}}^N \frac{(\delta z_p)(\delta z_k)}{2R_{pk}} + \sum_{\substack{k=1 \\ k \neq p}}^N \sum_{\substack{l=1 \\ l \neq p}}^N \frac{(\delta z_p)(\delta z_l)a_p^3 \vec{R}_{pk} \vec{R}_{pl}}{R_{pk}^3 R_{pl}^3} \right] \left[\frac{3\varepsilon_{st}^2}{(2\varepsilon_{st} + \varepsilon_i)^2} - \frac{1}{2} \right] \right\}$$

where $(\delta z_k) = z_k^f - z_k^i$, $R_{pk} = R_p - R_k$, z_k^i , and z_k^f are charge numbers of particle k in the initial and final states, respectively. The term a_p is the radius of particle p , R_k is the coordinate of k -particle center, and ε_i is the dielectric constant of reactant. It follows from the equation that E_s is proportional to the square of the number of charges transferred. Homogeneous multielectron processes are unlikely, due to the high activation energy resulting from a distinct rise in the energy of solvent reorganization. For multielectron reactions, the exchange currents of n -electron processes are small compared to those of single-electron multistep processes, which makes the stage-by-stage reaction mechanism more advantageous. Therefore, multielectron processes can proceed only if the formation of an intermediate is energetically disadvantageous. However, conditions can be chosen which reduce E_s during transfer of several charges to the level of the reorganization energy of ordinary single-electron reactions. These conditions require systems with a low dielectric constant and large reagent radii. Furthermore, the substrate must be included in the coordination sphere of the charge acceptor with several charge donors or acceptors bound into a multicenter complex. The term synchronous multielectron reaction does not mean that all n electrons started synchronously, since this is impossible according to quantum mechanics. Instead, each electron is transferred from donor to acceptor individually, but the time between successive electron transfer events is less than the time of reorganization of the medium. The expression for the probability of electron transfer at the interface between two immiscible liquids can be written as $W = A \exp \left\{ -\frac{U_i}{kT} - \frac{[E_s + \Delta G_c + U_f - U_i]^2}{4E_s kT} \right\}$, where U_i is the work that must be performed upon the system to place the reactants at distances h_1 and h_2 from the interface, U_f is the corresponding work for the reaction products,

ΔG_c is the configurational \rightarrow Gibbs energy, E_s is the solvent reorganization energy, and A is the pre-exponential factor, which is proportional to the transmission coefficient. Theoretical analysis shows that the most effective electron transfer takes place at the closest disposition of reaction centers. The difference between Gibbs energies for substrates and products can be found by using the \rightarrow Born equation corrected for the solvophobic effect $\Delta G_c = \Delta G_c(svp) + \frac{e_0^2}{4\pi\varepsilon_0} \left(\frac{n^2 + 2z_\alpha n}{2\varepsilon_\alpha a} + \frac{n^2 - 2z_\beta n}{2\varepsilon_\beta b} \right)$, where the solvophobic component of Gibbs energy $\Delta G_c(svp)$ does not depend on the electrostatic contribution. For a sharp interface between two immiscible liquids the solvent reorganization energy can be written as:

$$E_s = \frac{(ne_0)^2}{8\pi\varepsilon_0 a} \left(\frac{1}{\varepsilon_{op\alpha}} - \frac{1}{\varepsilon_\alpha} \right) + \frac{(ne_0)^2}{8\pi\varepsilon_0 b} \left(\frac{1}{\varepsilon_{op\beta}} - \frac{1}{\varepsilon_\beta} \right) + \frac{(ne_0)^2}{16\pi\varepsilon_0 h_\alpha} \left(\frac{\varepsilon_{op\alpha} - \varepsilon_{op\beta}}{\varepsilon_{op\alpha}(\varepsilon_{op\alpha} + \varepsilon_{op\beta})} - \frac{\varepsilon_\alpha - \varepsilon_\beta}{\varepsilon_\alpha(\varepsilon_\alpha + \varepsilon_\beta)} \right) - \frac{(ne_0)^2}{16\pi\varepsilon_0 h_\beta} \left(\frac{\varepsilon_{op\alpha} - \varepsilon_{op\beta}}{\varepsilon_{op\beta}(\varepsilon_{op\alpha} + \varepsilon_{op\beta})} - \frac{\varepsilon_\alpha - \varepsilon_\beta}{\varepsilon_\beta(\varepsilon_\alpha + \varepsilon_\beta)} \right) - \frac{(ne_0)^2}{2\pi\varepsilon_0(h_\alpha + h_\beta)} \left(\frac{1}{\varepsilon_{op\alpha} + \varepsilon_{op\beta}} - \frac{1}{\varepsilon_\alpha + \varepsilon_\beta} \right)$$

where ne_0 is the charge transferred in the reaction, subscripts α and β denote the dielectric permittivities (ε) in media α and β , and the reactants are spheres of radii a and b which are located at distances h_1 and h_2 from the interface with charges $z_1 e_0$ and $z_2 e_0$, respectively.

The simplest expressions for U_i and U_f are obtained when the reactions take place at equal distances from the interface, $h_1 = h_2 = h$:

$$U_i = \frac{z_\alpha z_\beta e_0^2}{4\pi\varepsilon_0(\varepsilon_\alpha + \varepsilon_\beta)h} + \frac{z_\alpha^2 e_0^2(\varepsilon_\alpha - \varepsilon_\beta)}{16\pi\varepsilon_0\varepsilon_\alpha(\varepsilon_\alpha + \varepsilon_\beta)h} - \frac{z_\beta^2 e_0^2(\varepsilon_\alpha - \varepsilon_\beta)}{16\pi\varepsilon_0\varepsilon_\beta(\varepsilon_\alpha + \varepsilon_\beta)h}$$

$$U_f = \frac{(z_\alpha + n)(z_\beta - n)e_0^2}{4\pi\varepsilon_0(\varepsilon_\alpha + \varepsilon_\beta)h} + \frac{(z_\alpha + n)^2 e_0^2(\varepsilon_\alpha - \varepsilon_\beta)}{16\pi\varepsilon_0\varepsilon_\alpha(\varepsilon_\alpha + \varepsilon_\beta)h} - \frac{(z_\beta - n)^2 e_0^2(\varepsilon_\alpha - \varepsilon_\beta)}{16\pi\varepsilon_0\varepsilon_\beta(\varepsilon_\alpha + \varepsilon_\beta)h}$$

In the case of homogeneous electron transfer in a dielectric medium, the work required to bring the reactants or reaction products together approaches zero when one of the reactants or products is electrically neutral, whereas in the process discussed here, U_i values are never zero because of the interactions with image charges.

Refs.: [i] Kharkats Yu I (1978) *Sov Electrochem* 14:172; [ii] Kharkats Yu I, Volkov AG (1985) *J Electroanal Chem* 184:435; [iii] Girault HHJ (1995) *J Electroanal Chem* 388:93; [iv] Marcus RA (1990) *J Phys Chem* 94:1050; [v] Volkov AG, Deamer DW, Tanelian DI, Markin VS (1998) *Liquid interfaces in chemistry and biology*. Wiley, New York

AV

Multi-cofactor enzyme — Multi-cofactor enzymes are redox proteins which contain more than one redox-active prosthetic group either in the same or in different subunits of the protein. Usually, these enzymes exhibit a predefined electron-transfer pathway between a primary redox site within the catalytic region of the enzyme to secondary redox sites which are intermediately storing the charge until it can be delivered to the biological redox partner. Multi-cofactor enzymes such as cellobiose dehydrogenase, quinoprotein alcohol dehydrogenase, sulfite oxidase, theophylline oxidase, or fructose dehydrogenase involve combinations of, e.g., PQQ and heme or FAD and heme, etc. Multi-cofactor enzymes are especially suitable to studying electron-transfer reactions between proteins and electrodes and as biological recognition element in amperometric biosensors. See also → *multiple electron transfer*, → *multielectron transfer reactions at the interface of dielectric media*.

Refs.: [i] Ikeda T, Kobayashi D, Matsushita F, Sagara T, Niki K (1993) *J Electroanal Chem* 361:221; [ii] Larsson T, Elmgren M, Lindquist SE, Tessema M, Gorton L, Henriksson G (1996) *Anal Chim Acta* 331:207; [iii] Gorton L, Lindgren A, Larsson T, Munteanu FD, Ruzgas T, Gazaryan I (1999) *Anal Chim Acta* 400:9; [iv] Schuhmann W, Zimmermann H, Habermüller K, Laurinavicius V (2000) *Faraday Discuss* 116:245; [v] Stoica L, Ludwig R, Haltrich D, Gorton L (2006) *Anal Chem* 78:393

WSchu

Multimeter — A multimeter is an analog or digital multipurpose – or universal measuring instrument, usually including standard measurement abilities for electric voltage (→ *voltmeter*), electric current (→ *ammeter*, amperemeter, galvanometer), and electric resistance (Ohmmeter) in one unit, often as a handheld device. More complex multimeters include the measurement of inductance and → *capacitance*, a sound notification for circuit continuity testing, autoranging, and often an amplifier to sense small voltages, currents, and high resistances. Analog multimeters are often referred to as ‘volt-ohm-meters’, VOM, digital m’s – as DMM.

Since the voltage is measured by putting the galvanometer across the voltage drop to be measured, whereas the current is measured by putting the meter in the circuit itself, for most accurate measurements, a volt-

meter needs a high input resistance, whereas an amperemeter – a very low resistance. At the same time, the current over the galvanometer has to be kept very small.

Modern multimeters may be equipped with memory possibilities, and/or interfaces to a personal computer by infrared, IrDA, or serial link, RS-232, or an instrument bus such as IEEE. Modern portable DMMs may have accuracies as good as ±0.025%, whereas nowadays bench-top instruments reach accuracies in the single-digit parts per million figures.

Ref.: [i] Gibilisco S (ed) (2001) *The illustrated dictionary of electronics*, 8th edn. McGraw-Hill, New York

MHer

Multiphase system — An inhomogeneous system consists of two or more phases of one or more substances. In electrochemistry, where all processes occur at the interface thus all measurement systems must contain at least two → *phases*. In common understanding so-called multi-phase systems contain more than two phases. Good examples of such systems are → *electrode* contacting a solid phase (immobilized at the electrode electroactive material or heterogeneous → *amalgams*) and electrolyte solution, and an electrode that remains in contact with two immiscible liquids [i]. All phenomena appearing in such multi-phase systems are usually more complicated and additional effects as → *interphase* formation and → *mass transport* often combined with → *ion transfer* must be taken into account [ii].

Refs.: [i] Scholz F, Schröder U, Gulaboski R (2004) *Electrochemistry of immobilized particles and droplets*. Springer, Berlin; [ii] Faghri A, Zhang Y (2006) *Transport phenomena in multiphase systems*. Elsevier, New York

MD

Multiple electron transfer — When redox moieties can accept (or donate) more than one electron the electrochemical response can show a series of waves or peaks each associated with a single electron transfer or single waves or peaks associated with concerted multiple electron transfers (see → *concerted electron transfers*). These multiple electron transfer sequences can be depicted as

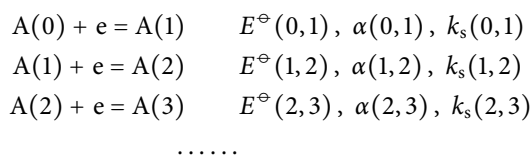

where $E^\ominus(n-1, n)$, $\alpha(n-1, n)$, $k_s(n-1, n)$ correspond to the standard potential, → *transfer coefficient* and standard rate constant of the reaction $A(n-1) + e =$

$A(n)$. A plethora of coupled homogeneous redox cross-reactions can also play a role in the system behavior, e.g., $2A(n) = A(n-1) + A(n+1)$ or $A(n+1) + A(n-1) = A(n+2) + A(n-2)$. A more general scheme could include additional coupled homogeneous reactions, e.g.:

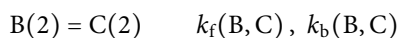
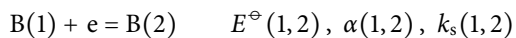
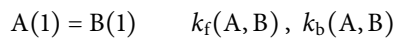
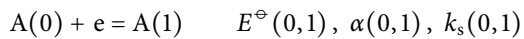

.....

Homogeneous kinetics may be considerably more complicated than the simple first-order reactions de-

picted here and could involve second-order protonations, dimerizations, and/or parent–daughter reactions as well as the aforementioned redox cross-reactions.

SWF

Multiplier → *Poggendorff*

Multiplier (multiplier) → *galvanoscope*

Multiwalled carbon nanotube → *carbon nanotubes*

MVN (modified Verwey-Niessen) model → *Verwey-Niessen model*

N

NADH — Reduced form of nicotinamide adenine dinucleotide (NAD^+). NADH and NAD^+ are important coenzymes in cellular energy production. With a \rightarrow *biochemical standard potential*, E' , of -0.32 V NADH is a key redox and hydrogen carrier in the metabolic substrate oxidation. Located in the cell plasma it serves as a cofactor, e.g., in the citric acid cycle and glycolysis in cell respiration. Together with NADPH/NADP^+ (nicotinamide adenine dinucleotide phosphate) it is essential for the functioning of NAD(P)^+ -dependent hydrogenases, as, e.g., lactate dehydrogenase, alcohol dehydrogenase, and glucose dehydrogenase. In this function it is also essential when NADH -dependent enzymes are used for \rightarrow *biosensors* and \rightarrow *biofuel cells*. At unmodified electrodes, the redox behavior of NADH/NAD^+ is rather irreversible. Whereas the oxidation of NADH to NAD^+ requires applying a large \rightarrow *overpotential* (electrochemical irreversibility) the reduction of NAD^+ often leads to the formation rather of the dimer than of NADH . One possibility to increase the stability and the electrochemical reversibility is to use modified electrodes that facilitate the two-electron redox processes (Fig.).

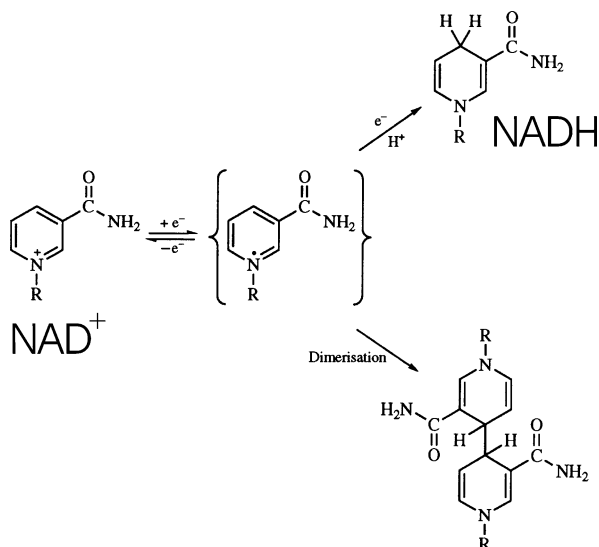

NADH — Figure. Structures of NADH and NAD^+ , and the reduction of NAD^+ [i]

Ref.: [i] Eggins BR (1996) *Biosensors: an introduction*. Wiley, Chichester US

Nafion[®] — registered trademark of E.I. DuPont de Nemours & Co. Nafion[®] is a copolymer consisting of sulfonate-terminated perfluorovinyl ether groups on a tetrafluoroethylene (Teflon) backbone (Fig.). It represents one of the prototypes of modern \rightarrow *polyelectrolytes* (ionomers) with a high proton conductivity thermal, chemical, and mechanical stability. The high ionic conductivity of Nafion is based on a microscopic morphology comprising interconnected micro-channels and sulfonate clusters [i, ii]. Nafion \rightarrow *membranes* are broadly used, examples are, e.g., \rightarrow *polymer electrolyte membrane fuel cells* (PEMFC) and technical electrolysis processes. Solutions of low-molecular-weight Nafion in alcohols have been used to cast films on electrode surfaces to produce polyelectrolyte polymer-modified electrodes [iii, iv] and to bind catalyst to membranes in PEMFCs.

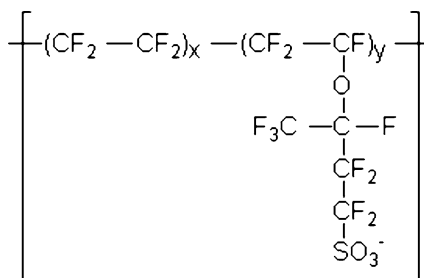

Nafion[®] — Figure. Structural formula of Nafion[®]

Refs.: [i] Heitner-Wirguin C (1995) *J Membrane Sci* 120:1; [ii] Mauritz KA, Moore RB (2004) *Chem Rev* 104:4535; [iii] Murray R (1992) *Molecular design of electrode surfaces*. Wiley, New York; [iv] Inzelt G (1994) *Mechanism of charge transport in polymer-modified electrodes*. In: Bard AJ (ed), *Electroanalytical chemistry*, vol. 18. Marcel Dekker, New York

US

Nanodes — Occasionally used term for \rightarrow *ultramicroelectrodes* with nm dimensions. It has several meanings outside of electrochemistry. The term \rightarrow *nanoelectrodes* is probably more descriptive and preferred.

FS, AJB

Nanoelectrode — Electrode with a characteristic dimension below $1\ \mu\text{m}$. See \rightarrow *ultramicroelectrode* (UME).

CGZ

Nanoelectrodes in SECM — For the improvement of the lateral resolution in \rightarrow *scanning electrochemical microscopy* (SECM) the size of the \rightarrow *ultramicroelectrode*

used as tip has to be decreased. Moreover, due to the dependence of the tip-to-sample distance from the tip size, smaller electrodes unequivocally require an accurate positioning of the SECM tip in constant distance throughout scanning. In order to decrease the size of the active electrode surface below the minimum size of the commercially available noble-metal wires mainly electrochemical etching procedures were described leading to conically shaped ultramicroelectrodes. Insulated etched tips were prepared using apiezon wax, electrophoretic paint, electrochemically deposited self-limiting polymer films or poly(ethylene). Recently, the use of a laser puller for the fabrication of ultramicroelectrodes was proposed. The obtained nanoelectrodes were characterized by means of electron microscopy, cyclic voltammetry, and z-approach curves in SECM. In combination with shear force-dependent constant-distance positioning in SECM, nanoelectrodes were successfully applied for the imaging of local electrochemical activity of samples at high resolution.

Refs.: [i] Fish G, Bouevitch O, Kokotov S, Lieberman, Palanker D, Turovets I, Lewis A (1995) *Rev Sci Instr* 66:3300; [ii] Shao YH, Mirkin MV, Fish G, Kokotov S, Palanker D, Lewis A (1997) *Anal Chem* 69:1627; [iii] Sun P, Zhang ZQ, Guo JD, Shao YH (2001) *Anal Chem* 73:5346; [iv] Katemann BB, Schuhmann T (2002) *Electroanalysis* 14:22; [v] Zoski CG (2002) *Electroanalysis* 14:1041; [vi] Lugstein A, Bertagnolli E, Kranz, Kueng A, Mizaikoff B (2002) *Appl Phys Lett* 81:349; [vii] Sklyar O, Wittstock G (2002) *J Phys Chem B* 106:7499; [viii] Katemann BB, Schulte A, Schuhmann W (2004) *Electroanalysis* 16:60; [ix] Sklyar O, Treutler TH, Vlachopoulos N, Wittstock G (2005) *Surf Sci* 597:181; [x] Fan FR, Bard AJ (1999) *PNAS USA* 96:14222; [xi] Ufheil J, Hess C, Borgwarth K, Heinze J (2005) *Phys Chem Chem Phys* 7:3185

WSchu

Nanoparticles — Nanoparticles are small solid-state particles with dimensions below ca. 100 nm. Due to the small size, nanoparticles exhibit a range of interesting physical and chemical properties different from those of the corresponding bulk material. The most striking phenomenon observed with electrically conductive nanoparticles is the transition from high density of states in macroscopic particles to more separated (quantized) energy levels in nanoparticles with dimensions decreasing below ca. 10 nm. While a macroscopic particle has physical properties invariant with particle size, a nanoparticle may show physical properties dramatically changing with its size, for instance, Cu nanoparticles with diameter $\phi < 50$ nm become super hard, Pt nanoparticles with $\phi < 5$ nm lose their catalytic properties toward oxygen reduction and methanol oxidation, and CdS nanoparticles with $\phi < 10$ nm exhibit

continuously changing absorption band edge and visible color changes with decreasing diameter.

Very important are electronic, optical, and magnetic properties of nanoparticles. → *Semiconductor* nanoparticles, called quantum dots for their small size and quantized energy levels, have been utilized in single electron transistors, charge-coupled devices, cancer research and imaging, dye-sensitized solar cells, and other applications. Optical absorption, excited states, and luminescence of Cd chalcogenides have been extensively studied. Various forms of ZnO nanoparticles (e.g., nanorods) have been proposed for nanolasers and assemblies of various nanoparticles have been utilized as photonic crystals with well-defined optical bandgap. Magnetic nanoparticles (Fe_2O_3 , Fe_3O_4) have been mass produced for computer memory devices and for biotechnology as carriers of bioactive compounds, sensory materials, and cells. Electrodeposited semiconducting WO_3 nanoparticles have been characterized in electrochromic and solar cell applications. The TiO_2 nanoparticles exhibit antibacterial properties and are widely used in hospitals and homes for disinfecting and self-cleaning purposes, also as an addition to ceramic tiles and paints. TiO_2 nanoparticles are also used as an antifogging coating since its hydrophilic/hydrophobic properties can be controlled by the method of preparation. TiO_2 nanoparticles play an important role in cancer research, photoelectrocatalysis, and electrochemical solar cells. Gold paints with Au nanoparticles have been known for centuries.

The methods of nanoparticle preparation are very diverse and include solution chemistry (ageing of solutions containing reactive components), electrochemical → *nucleation* and growth on electrodes, spray pyrolysis, chemical vapor deposition, reactive plasma processing, magnetron sputtering, electric arc processes, thermal evaporation, etc. The nanoparticle form ranges from monodispersed spheres, crystalline cubes, pyramids, and other regular shapes, platelets, flakes, nanorods, nanonails, and nanobridges (ZnO), tetrapods, to → *nanowires* and → *nanotubes*. The crystallinity of nanoparticles depends on the preparation method and final annealing. Thus, low-temperature syntheses often yield amorphous structures, whereas the high temperature tends to generate crystalline structures. Usually, annealing at temperatures above ca. 300 °C converts samples to crystalline state.

Multicomponent and complex nanoparticle structures have been designed. For instance, $\text{Pt}_{22}\text{V}_{35}\text{Fe}_{43}$ ternary alloy nanoparticles have been synthesized by

manipulating feeding ratios of the metal precursors and reducing agent 1,2-hexadecanediol followed by thermal decomposition. The magnetic $\text{Fe}_3\text{O}_4|\text{Au}$ nanoparticles with Fe_3O_4 core and Au shell with controllable capping properties, allowing for subsequent control and manipulation of interparticle interactions and reactivities, have been synthesized by solution chemistry.

Some of the nanoparticle properties are due to the increasing percentage of their atoms being at the surface in relation to the atoms residing inside the particle, as the nanoparticle size decreases. The surface atoms extend outwards some dangling bonds, present on the surface due to the termination of the solid. The miniscule mass of nanoparticles, in conjunction with strong interactions with the medium (dangling bonds), make it easy to suspend nanoparticles in various solvents. The nanoparticle colloidal dispersions (often called: solutions) are usually thermodynamically stable, in contrast to large particles which may sink or float in a given liquid due to the density difference.

Due to the small size, nanoparticles are often used as building blocks in designing large assemblies and core-shell nanoparticle networks with various functionalities.

Refs.: [i] Templeton AC, Murray RW (2000) *Acc Chem Res* 33:27; [ii] Hepel M, Hazelton S (2005) *Electrochim Acta* 50:5278; [iii] Luo J, Maye MM, Lou Y, Han L, Hepel M, Zhong CJ (2002) *Catalysis Today* 77:127

MHep

Nanotubes — are cylindrical molecules with diameters of a few nanometers and up to a few centimeters in length. The most popular are carbon nanotubes, but inorganic (e.g., metal oxide) nanotubes also exist. Organic (e.g., \rightarrow *conducting polymer*) type nanotubes have been postulated as well. Carbon nanotubes can be viewed as the allotropic forms of \rightarrow *carbon* linked by the sp^2 bonds only. They have unique properties, like resistance to mechanical stress (as the sp^2 bond is stronger than the sp^3 one) and good electric (ballistic) conductivity and thermal conductivity. They are very strong materials along the axes of symmetry. They are hollow structures, thus they are much less resistant to compressive, torsional, or bending stresses. In general, upon application of stress, they undergo plastic deformation. There are two types of nanotubes, single- and multi-walled. Single-walled nanotubes are less common. They consist of nanotubes not containing smaller nanotubes inside, as opposed to multi-walled nanotubes consisting of many single-walled nanotubes nested one into another. Multi-walled nanotubes can slide and rotate without friction. Those properties of multi-walled nan-

otubes have been utilized in construction of nanosized rheostats and rotational actuators, that can be viewed as real examples of nanotechnology. The nanotubes were discovered in 1952 by Radushkevich and Lukyanovich. The materials are synthesized using arc discharge, laser ablation, high-pressure carbon monoxide, and chemical vapor deposition methods. Inorganic nanotubes resemble the carbon ones, and they are usually composed of metal oxides. When compared to carbon nanotubes, they are not so resistant to tensile stresses but they exhibit higher resistance to compression. This feature makes them potentially attractive for such applications where large stresses are expected, i.e., in bullet-proof vests.

Refs.: [i] Monthieux M, Kuznetsov VL (2006) *Carbon* 44:1621; [ii] Yu MF, Lourie O, Dyer MJ, Moloni K, Kelly TF, Ruoff RS (2000) *Science* 287:637; [iii] Fennimore AM, Yuzvinsky TD, Han WQ, Fuhrer MS, Cumings J, Zettl A (2003) *Nature* 424:408; [iv] Cumings J, Zettl A (2004) *Phys Rev Lett* 93:086801; [v] Tenne R, Margulis L, Genut M, Hodes G (1992) *Nature* 360:444

PK

Nanowires — Nanowires are solid-state or molecular structures with cross-sectional width W ranging from a fraction of nm (atomic size) to ca. 100 nm, and unrestricted length L . The cross section is critical since it controls the nanowire properties, which are different from those of the bulk material. The electrical conductivity of nanowires can span a wide range of values, from those typical of metals to semiconductors and insulators. The conductance type can be metallic (conforming to free electron gas model with inelastic electron scattering), n -type or p -type semiconductive (band theory with delocalized states), electron-hopping type (transfer between localized states), electron tunneling, etc. Some nanowires exhibit metal-semiconductor transitions when the wire cross section is decreased (e.g., Bi nanowires with diameter $\phi > 48$ nm are semimetallic and those with diameter $\phi < 48$ nm are semiconducting).

The conductance scaling of metallic nanowires is very interesting and can be divided into three ranges:

- (a) classical conductance range, for nanowires longer than the electron mean free path L_e and wider than deBroglie wavelength λ_e :

for $L > L_e$, $W > \lambda_e$: $G = \sigma_{\text{Me}}(A/L)$, where G is the conductance measured in siemens [S], σ_{Me} is the specific conductivity dependent on the material [S/m], A is the wire cross section [m^2], and L is the wire length [m].

(b) classical conductance with finite size effects when:

$L < L_e$, $W > \lambda_e$: ballistic electron transport, G independent of material,

(c) quantum conductance range when: $L < L_e$, $W \leq \lambda_e$:
 $G = g_0 n$,

where $g_0 = 2e^2/h$ is the minimum conductance, n is the number of conductance channels for degenerate states, e is the \rightarrow elementary electric (electron) charge, and h is the \rightarrow Planck constant. The value of g_0 is then: $g_0 = 77.48 \mu\text{S}$, equivalent to the resistance of $12.906 \text{ k}\Omega$. The quantum conductance is not associated with superconductivity. Interesting properties of quantum nanowires and nanobridges are attributed to the narrow constriction resulting in quantized conductance, temperature invariance, and high current-carrying capability. Single-walled and multi-walled \rightarrow carbon nanotubes, with diameter on the order of 2 nm are also excellent conductors and can serve as nanowires in electronic circuits.

Nanowires are essential part of nanotechnology and their importance is surging due to insatiable growth of nanoelectronic applications.

Refs.: [i] Sharvin YV (1965) *Zh Eksp Teor Fiz* 48:984; [ii] Landauer R (1970) *Philos Mag* 21:863; [iii] Heipel M (2006) *Electrochim Acta* 51:5811 MHep

NASICON — (**Na Super Ionic Conductor**) is a family of sodium cation-conducting solid materials, comprising both \rightarrow solid electrolytes and mixed ionic–electronic \rightarrow conductors. The general formula is $(\text{Na}1)_n(\text{Na}2)_m[\text{A}_2\text{B}_3\text{O}_{12}]$ ($n = 0-1$; $m = 0-3$; $\text{B} = \text{Si}, \text{P}, \text{Ge}, \text{As}$); the crystal structure comprises AO_6 octahedra, BO_4 tetrahedra, and two types of interstitial Na^+ cations, namely octahedrally-coordinated $\text{Na}1$ and 10-coordinated $\text{Na}2$. The A sites can be occupied by a variety of cations, including Zr, Ti, Hf, Sn, Nb, V, Y, Sc, Mg, Fe, Co, Na, rare-earth ions, etc. The first group of \rightarrow superionic compounds discovered in this system, was $\text{Na}_{1+x}\text{Zr}_2\text{Si}_x\text{P}_{3-x}\text{O}_{12}$ [i, ii]; one representative, $\text{Na}_3\text{Zr}_2\text{PSi}_2\text{O}_{12}$ was found to exhibit a high level of sodium \rightarrow ion conductivity, comparable to that of \rightarrow β -alumina ($\sim 10 \text{ Sm}^{-1}$ at 573 K). The \rightarrow diffusion of cations occurs in the channels formed by $\text{Na}1$ and $\text{Na}2$ positions, partially empty [iii]. Attractive members of this family include $\text{Na}_3\text{Sc}_2(\text{PO}_4)_3$ with a high ionic conductivity, mixed-conducting $\text{Na}_{1+4x}\text{M}_x^{\text{II}}\text{Fe}_{2x}^{\text{III}}\text{Zr}_{2-3x}(\text{PO}_4)_3$ ($\text{M}^{\text{II}} = \text{Fe}^{2+}, \text{Co}^{2+}, \text{Ni}^{2+}$), and their derivatives [iv, v]. The transport properties of NASICON-based ceramics are often affected by minor grain-boundary segregation of secondary phases and resultant compositional deviations (\rightarrow grain boundaries).

Refs.: [i] Goodenough JB, Hong HY-P, Kafalas JA (1976) *Mater Res Bull* 11:203; [ii] Hong HY-P, Kafalas JA, Bayard ML (1978) *Mater Res Bull* 13:757; [iii] Bohnke O, Ronchetti S, Mazza D (1999) *Solid State Ionics* 122:127; [iv] Tillimont O, Angenault J, Couturier JC, Quarton M (1991) *Solid State Ionics* 44:299; [v] Susman S, Delbecq CJ, Brun TO, Prince E (1983) *Solid State Ionics* 9/10:825

VK

Navier–Stokes equation — The Navier–Stokes equation is one of the equations used to derive the velocity profile of an incompressible fluid:

$$\rho \frac{d\mathbf{v}}{dt} = -\nabla P + \eta \nabla^2 \mathbf{v} + \mathbf{f}$$

with density ρ of the fluid, \mathbf{v} the velocity vector, η the viscosity, and \mathbf{f} the force/volume exerted on a fluid element by gravity. The term $\eta \nabla^2 \mathbf{v}$ represents frictional forces. Using the kinematic \rightarrow viscosity $\nu = \eta/\rho$ and rearranged the Navier–Stokes equation is frequently written as:

$$\frac{d\mathbf{v}}{dt} = -\frac{1}{\rho} \nabla P + \nu \nabla^2 \mathbf{v} + \frac{\mathbf{f}}{\rho}$$

Refs.: [i] Bard AJ, Faulkner LR (2001) *Electrochemical methods*, 2nd edn. Wiley, New York; [ii] Pleskov YuV, Filinovskii VYu (1976) *The rotating disc electrode*. Consultants Bureau, New York

RH

NIR (near infra red) spectroscopy \rightarrow spectroscopy

NEMCA effect — The term NEMCA is the acronym of Non-faradaic Electrochemical Modification of Catalytic Activity. The NEMCA effect is also known as electrochemical promotion (EP) or electropromotion. It is the effect observed on the rates and selectivities of catalytic reactions taking place on electronically conductive catalysts deposited on ionic (or mixed ionic–electronic) supports upon application of electric current or potential (typically $\pm 2 \text{ V}$) between the catalyst and a second (counter or auxiliary) electrode also deposited on the same support. The catalytic reactants are usually in the gas phase.

The NEMCA effect was first reported in 1981 [i] for the case of the oxidation of C_2H_4 by gaseous O_2 on porous Ag catalyst films deposited on Y_2O_3 -stabilized- ZrO_2 (YSZ), an O^{2-} conductor, and has been described in the literature for more than 80 catalytic systems on a variety of catalysts (Pt, Pd, Rh, Ag, IrO_2 , RuO_2 , Ni, Cu, Au, etc.) using numerous anionic (YSZ, CaF_2), cationic (β'' - Al_2O_3 , $\text{Na}_3\text{Zr}_2\text{Si}_2\text{PO}_{12}$, $\text{K}_2\text{YZr}(\text{PO}_4)_3$, $\text{CaZr}_{0.9}\text{In}_{0.1}\text{O}_{3-a}$, CsHSO_4 , Nafion), or

mixed electronic–ionic (TiO₂, CeO₂, YZTi) supports and also aqueous and molten salt electrolytes [ii–v].

The observed change in catalytic rate is typically 5 to 10⁵ times larger than the electrochemical reaction rate (i.e., the rate of ionic transport in the support, or the rate of ion supply to or ion removal from the catalyst) thus the effect is strongly non-faradaic. The electropromoted catalytic reaction rate is typically 2–500 times larger than the open-circuit (i.e., unpromoted) catalytic rate.

The product selectivity is also significantly affected by the NEMCA effect, which is usually quite reversible, although at lower temperatures a “permanent” NEMCA effect is often observed [iv, v].

Electrochemical and surface spectroscopic techniques [iii, v] have shown that the NEMCA effect is due to electrochemically controlled (via the applied current or potential) migration of ionic species (e.g., O^{δ-}, Na^{δ+}) from the support to the catalyst surface (catalyst–gas interface). These ionic species serve as promoters or poisons for the catalytic reaction by changing the catalyst work function Φ [ii, v] and directly or indirectly interacting with coadsorbed catalytic reactants and intermediates [iii–v].

The magnitude of the NEMCA effect for a given catalytic system is commonly described by two parameters, the rate enhancement ratio, ρ , ($= r/r_0$, where r and r_0 are the electropromoted and unpromoted reaction rate values) and the faradaic efficiency, Λ , ($= (r - r_0)/(I/nF)$), where I is the current, F is the Faraday constant, and n is the charge of the promoting ion. The magnitude of Λ can be predicted from the parameter $2Fr_0/I_0$, where I_0 is the exchange current of the catalyst–support interface [v].

During investigation of the NEMCA effect the rates of catalytic reactions were found to depend on catalyst work function, Φ , via the equation $\ln(r/r_0) = \alpha\Phi/k_B T$ where α is a reaction-specific constant and k_B is the → Boltzmann constant.

Depending on the rate, r , dependence on catalyst potential and work function, heterogeneous catalytic reactions are classified in four categories, i.e., electrophobic ($\alpha > 0$, $\partial r/\partial\Phi > 0$), electrophilic ($\alpha < 0$, $\partial r/\partial\Phi < 0$), volcano and inverted volcano [v]. Rigorous rules have been derived which predict to which category a catalytic reaction belongs on the basis of the reaction kinetics [v].

The NEMCA effect is closely related to classical promotion and to the phenomenon of metal–support interactions (MSI) with oxide supports and that MSI can be viewed as a self-driven NEMCA microsystem where the promoting O²⁻ ions are thermally migrating from the support to the dispersed catalyst nanoparticles and replenished in the support by gaseous O₂ [v].

Refs.: [i] Stoukides M, Vayenas CG (1981) *J Catal* 70:137; [ii] Vayenas CG, Bebelis S, Ladas S (1990) *Nature* 343:625; [iii] Lambert RM, Williams F, Palermo A, Tikhov MS (2000) *Topics Catal* 13:91; [iv] Fôti G, Bolzonella I, Comninellis C (2003) *Electrochemical promotion of catalysis*. In: Vayenas CG, Conway BE, White RE (eds) *Modern aspects of electrochemistry – electrochemical promotion of catalysis*, vol. 36. Kluwer/Plenum, New York; [v] Vayenas CG, Bebelis S, Pliangos C, Brosda S, Tsiplakides D (2001) *Electrochemical activation of catalysis: promotion, electrochemical promotion and metal–support interactions*. Kluwer/Plenum, New York

CV

Nernst, Walther Hermann



(© The Nobel Foundation)

(June 25, 1864, Briesen, West Prussia, Germany, now Wąbrzeźno, Poland – Nov. 18, 1941, Zibelle, Germany, now Niwica, Poland) Ph.D. 1887 in Würzburg, worked together with → Ostwald, F.W. at Leipzig University, 1888 → *Nernst equation*, 1890/91 Nernst distribution law, 1893 1st edition of his book “Theoretische Chemie vom Standpunkte der Avogadro’schen Regel und der Thermodynamik (Theoretical chemistry from the standpoint of Avogadro’s rule and thermodynamics)”; 1894 Professor of Physical Chemistry in Göttingen, where he founded the Institute for Physical Chemistry and Electrochemistry and became its Director, 1897 → *Nernst Lamp*, 1905–1924 Professor of Chemistry at the University of Berlin, 1905 Third law of thermodynamics, 1920 Nobel Prize in Chemistry, 1924–1933 Professor of Physics at the University of Berlin. Nernst made fundamental contributions not only to electrochemistry, but also to the theory of solutions, → *thermodynamics*, solid-state chemistry and photochemistry. See also the following entries.

Refs.: [i] *Nobel lectures, chemistry 1901–1921* (1966). Elsevier, Amsterdam; [ii] Medelssohn K (1973) *The world of Walther Nernst. The rise and fall of German science*. University of Pittsburgh Press, Pittsburgh; [iii] Barkan D (1999) *Walther Nernst and the transition to modern physical science*. Cambridge University Press, Cambridge

JB

Nernst–Einstein equation → *Nernst* derived the relationship between the → *diffusion coefficient* D_{KA} of 1:1 electrolyte and the mobilities of the individual ions (u_K , u_A) [i]:

$$D_{KA} = \frac{RT}{F} \frac{2u_K u_A}{u_K + u_A}.$$

→ *Einstein* presented an equation relating the diffusion coefficient of species i (D_i) to the frictional coefficient in a diffusion process [ii], this can be transformed into a relationship between → *ionic mobility* u_i and → *diffusion coefficient* D_i

$$D_i = \frac{RTu_i}{|z_i|F}$$

wherein R is the → *gas constant*, T is the temperature, F is the → *Faraday constant*, and z_i is the → *charge number* of species i . (The mobility is often used instead of frictional resistance.)

Further development results in the Nernst–Einstein equation

$$\Lambda_0 = \frac{F^2}{RT} (\nu_+ z_+^2 D_+ + \nu_- z_-^2 D_-)$$

describing the relationship between molar conductivity at infinite dilution Λ_0 , the diffusion coefficient, the number of charges on an ion z , and the stoichiometric ν coefficient.

Refs.: [i] *Nernst W (1888) Z phys Chem 2:613*; [ii] *Einstein A (1905) Ann Phys 17:549*

GI, RH

Nernst equation — A fundamental equation in → *electrochemistry* derived by → *Nernst* at the end of the nineteenth century assuming an osmotic equilibrium between the metal and solution phases (→ *Nernst equilibrium*). This equation describes the dependence of the equilibrium electrode → *potential* on the composition of the contacting phases. The Nernst equation can be derived from the → *potential of the cell reaction* ($E_{\text{cell}} = \Delta G/nF$) where ΔG is the → *Gibbs energy* change of the → *cell reaction*, n is the charge number of the electrochemical cell reaction, and F is the → *Faraday constant*.

For the cell reaction $0 = \sum \nu_i A_i$, where A_i symbolizes the species taking part in the chemical reaction and ν_i is for the respective stoichiometric numbers, the following equation can be written:

$$E_{\text{cell}} = E^\ominus - (RT/nF) \sum_i \nu_i \ln a_i \quad (1)$$

where $E^\ominus = \Delta G^\ominus/nF$ is the standard → *potential* of the cell reaction, R is the → *gas constant*, T is the tem-

perature (in K). Sometimes Eq. (1) is also called Nernst equation. When the **cell reaction** is at equilibrium, i.e., $\Delta G = 0$, $E_{\text{cell}} = 0$: $E^\ominus = (RT/nF) \ln K$ where K is the equilibrium constant of the cell reaction.

It follows that for the equilibrium electrode potential, E

$$E = E^\ominus - (RT/nF) \sum_i \nu_i \ln a_i$$

when the → *reference electrode* is the → *standard hydrogen electrode*, where E^\ominus is the standard potential of the → *electrode reaction*.

For a solution containing the oxidized (O) and reduced form (R) of a redox couple $O + n e^- = R$ at activities a_O and a_R , respectively, the redox potential (E) is given by the Nernst equation, as follows:

$$E = E^\ominus + \frac{RT}{nF} \ln \frac{a_O}{a_R} \approx E^\ominus + \frac{2.303RT}{nF} \log \frac{a_O}{a_R}$$

where E^\ominus is the → *standard potential* of the redox couple.

The Nernst equation is applicable also to interfacial ionic equilibria where the activity of an ion is equal to a_i (1) at one side of the interface and a_i (2) at the other side, as follows:

$$E = E^\ominus + \frac{RT}{z_i F} \ln \frac{a_i(1)}{a_i(2)}$$

where z_i is the charge of the ion.

Very often concentrations are used in the Nernst equation instead of activities. In this case the only difference is that the standard potential is replaced by the → *formal potential* in the equation.

Refs.: [i] *Nernst W (1888) Z phys Chem 2:613*; [ii] *Bockris JO'M, Reddy AKN, Gamboa-Aldeco M (2000) Modern electrochemistry, vol. 2A, 2nd edn. Kluwer/Plenum, New York*; [iii] *Bard AJ, Faulkner LR (2001) Electrochemical methods, 2nd edn. Wiley, New York*

JB

Nernst equilibrium — It was → *Nernst* who first treated the thermodynamical → *equilibrium* for an → *electrode* [i], and derived the → *Nernst equation*. Although the model used by Nernst was not appropriate (see below) the Nernst equation – albeit in a modified form and with a different interpretation – is still one of the fundamental equations of electrochemistry. In honor of Nernst when equilibrium is established at an electrode, i.e., between the two contacting phases of the electrode or at least at the interface (interfacial region), it is called Nernst equilibrium. In certain cases (see → *reversibility*) the Nernst equation can be applied also when current flows. If this situation prevails we speak of reversible or

nernstian reaction (reversible or nernstian system, nernstian response of an electrode) [ii, iii].

Nernst, while working under the guidance of → *Ostwald*, F.W. in Leipzig, derived his famous equation by using van't Hoff's osmotic theory [i, iv, v]. According to Nernst the reason for the dissolution of a metal or the deposition of metal ions is a pressure difference. Two types of pressures exist, i.e., the osmotic pressure (p) exerted by the dissolved molecules (ions) on the metal surface (which acts as a semipermeable membrane) and an opposite one, the "Lösungstension" ("dissolution tension") of the metal (P), which drives the ions into the solution. An equilibrium will be established when $p = P$. The equation for the metal-electrolyte potential difference (E) in Nernst's original work [i] was given as follows:

$$E = p_0 \ln \frac{P}{p} \quad (1)$$

where p_0 is a constant of the Boyle–Mariotte equation ($p_0 = pV$). In fact, dE was considered as a work, i.e., $dE = -Vdp$, where V is the volume of the cation under the pressure p .

In 1921 Nernst still insisted on his inappropriate model, and gave the following equation:

$$E = \frac{RT}{n} \ln \frac{C}{c} \quad (2)$$

where R is the gas constant, n is the chemical valency of the ion concerned, C is a constant specific to the electrode, and c is the ion concentration [iv].

Refs.: [i] Nernst W (1889) *Z phys Chem* 4:129; [ii] Bard AJ, Faulkner LR (2001) *Electrochemical methods*, 2nd edn. Wiley, New York, p 161; [iii] Inzelt G (2002) *Kinetics of electrochemical reactions*. In: Scholz F (ed) *Electroanalytical methods*. Springer, Berlin, pp 32, 39–44; [iv] Nernst W (1921) *Studies in chemical thermodynamics*. Nobel Lectures, Chemistry 1901–1921 (1966). Elsevier, Amsterdam; [v] Inzelt G (2006) *J Solid State Electrochem* 10:1008

GI

Nernst factor → *nernstian slope*

Nernst lamp — In 1897 → *Nernst* filed his first patent of a lamp [i] that was later referred to as the Nernst lamp. The light-emitting unit was a rod consisting of a sintered mixture of ZrO_2 and Y_2O_3 , i.e., yttria-stabilized zirconia (→ *stabilized zirconia*), an oxide ion conductor. This rod was heated by passing through an electric current (DC). The rod had to be preheated because the conductivity is negligible at room temperature. The advantage of the Nernst lamp was that the rod had to be electrically heated in ambient air and did not need a vacuum bulb, its



Nernst lamp — **Figure.** Nernst lamp (Copyright: Museum für Energiegeschichte, Hannover)

high luminosity, white light, and long maintenance-free operating. In 1903, already 1 million Nernst lamps had been produced. Later the Nernst lamp could not compete with metal wire lamps, although recent patent literature indicates an ongoing interest in the concept of the Nernst lamp. The stabilized zirconia of the Nernst lamp was the first high-temperature → *solid electrolyte* used in practice, and it can be regarded as the starting point of → *solid state electrochemistry*, and many applications such as the → *lambda probe*, and many other applications of solid electrolytes. The Nernst glower (electrically heated stabilized zirconia) is still in use as an infrared radiation source.

Refs.: [i] Nernst W (1897) D.R.P. 104 872 July 6th, 1897; [ii] Bartel HG, Scholz G, Scholz F (1983) *Z Chem* 23:277

FS

Nernst law of electrical nerve stimulus threshold

→ *Nernst* discovered the law that the minimum current that causes a physiological stimulation increases proportionally to the square root of the frequency.

Refs.: [i] Nernst W (1899) *Nachr Kgl Ges Wiss Gött*, No. 1, 104 (<http://dz-srv1.sub.uni-goettingen.de/cache/toc/D54774.html>);

[ii] Nernst W (1908) *Pflügers Archiv ges Physiologie* 122: 275 (DOI: 10.1007/BF01677956)

FS

Nernst layer → *Diffusion* of electroactive species from the bulk solution to the → *electrode* surface, or vice versa, takes place in a thin layer of stagnant solution close to the electrode/solution interface when the concentration of electroactive species at this interface, c_i ($x = 0$), deviates from the bulk concentration c_i^* (see Figure). The concentration gradient at the electrode/solution interface drives the diffusion flux of electroactive species. Generally, there is a linear concentration profile close to the electrode surface and at longer distances from the electrode surface the concentration asymptotically approaches the bulk concentration. The Nernst layer is ob-

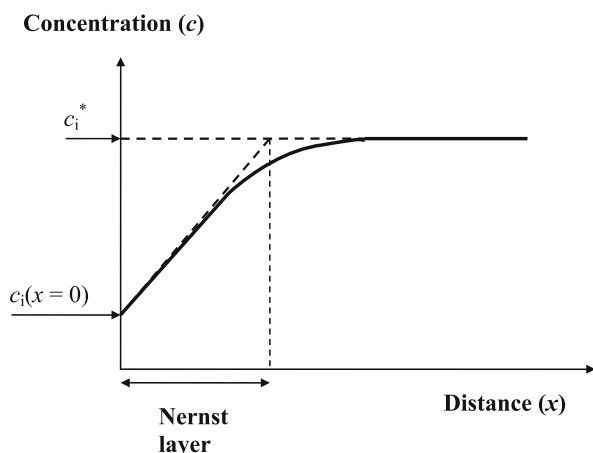

Nernst layer — Figure

tained by extrapolation of the linear part of the concentration vs. distance curve to the bulk concentration, as shown in the Figure. The Nernst-layer approximation simplifies the analysis of transport-controlled electrode reactions.

The thickness of the Nernst layer increases with the square root of time until natural \rightarrow convection sets in, after which it remains constant. In the presence of forced convection (stirring, electrode rotation) (see also \rightarrow Prandtl boundary layer), the Nernst-layer thickness depends on the degree of \rightarrow convection that can be controlled e.g., by controlling the rotation speed of a \rightarrow rotating disk electrode. See also \rightarrow diffusion layer. See also \rightarrow Fick's law.

Refs.: [i] Bockris JO'M, Reddy AKN, Gamboa-Aldeco M (2000) *Modern electrochemistry*, vol. 2A, 2nd edn. Kluwer/Plenum, New York; [ii] Ibl N (1981) *Pure Appl Chem* 53:1827

JB

Nernst–Planck equation — This equation describes the flux of charged particles by \rightarrow diffusion and electrostatic forces. When the ion with charge ze is distributed at concentration c in the potential, ϕ , it has a one-dimensional flux of the ion, $J = -D\partial c/\partial x - (zF/RT)Dc\partial\phi/\partial x$ [i]. This can be derived from the concept that the force caused by the gradient of the \rightarrow electrochemical potential is balanced with frictional force by viscosity, η , of the medium. When a spherical ion with radius r_0 is in the inner potential, ϕ , the gradient of the electrochemical potential per ion is given by

$$\begin{aligned}\text{grad}\bar{\mu} &= \text{grad}(\mu^\circ + k_B T \ln(c/c^\circ) + ze\phi) \\ &= (k_B T/c)\text{grad}c + ze\text{grad}\phi.\end{aligned}$$

This force makes the ion move at velocity v . Since this is equal to the Stokes' frictional force, $6\pi\eta r_0 v$, the flux, $J = -cv$, is given by

$$J = -D\text{grad}c - cD(zF/RT)\text{grad}\phi.$$

See also \rightarrow Onsager relations, \rightarrow migration, \rightarrow diffusion, and subentry \rightarrow convective diffusion.

Ref.: [i] Atkins PW (1998) *Physical chemistry*. Oxford University Press, Oxford, pp 737–738

KA

Nernstian behavior \rightarrow Nernst equilibrium

Nernstian electrode reaction — An \rightarrow electrode reaction proceeding at electrochemical \rightarrow equilibrium. Therefore the \rightarrow Nernst equation is applicable. See \rightarrow reversibility.

FS

Nernstian reaction \rightarrow Nernst equilibrium

Nernstian response \rightarrow Nernst equilibrium

Nernstian slope — A nernstian slope is equal to the pre-logarithmic term of the \rightarrow Nernst equation, i.e., $2.303(RT/nF)$. An \rightarrow ion-selective electrode is thus said to have a nernstian slope when the slope of the linear part of the calibration plot of the potential vs. the logarithm of the activity of a given ion (a_i) with charge z_i is equal to $2.303(RT/z_i F)$ (59.16/ z_i) mV per unit of $\log a_i$ at 25 °C). Analogously, a \rightarrow redox electrode is said to have a nernstian slope when the slope of the linear part of the calibration plot of the potential vs. the logarithm of the activity ratio (a_O/a_R) of a given \rightarrow redox couple $O + ne^- = R$ is equal to $2.303(RT/nF)$. See also \rightarrow Nernst equilibrium, \rightarrow potentiometry, \rightarrow sub-nernstian slope.

Ref.: [i] Guilbault GG, Durst RA, Frant MS, Freiser H, Hansen EH, Light TS, Pungor E, Rechnitz G, Rice NM, Rohm TJ, Simon W, Thomas JDR (1976) *Pure Appl Chem* 48:127

JB

Nerve conduction \rightarrow action potential, \rightarrow graded potential

Neumann (von ~) boundary condition \rightarrow von Neumann boundary condition

Neurotransmitters, electrochemical detection — Neurotransmitters such as catecholamines (dopamine, serotonin), glutamate, γ -amino butyric acid (GABA), or NO are low-molecular compounds which are released upon stimulation from neurons enabling

chemical communication with neighboring cells. Often neurotransmitters are released from storage vesicles by means of exocytosis. Neurotransmitters which can be directly converted at an electrode either by oxidation or reduction at a suitable applied potential can be directly detected using microelectrodes positioned in close vicinity to the release site at the cell. First approaches have used carbon fiber microelectrodes positioned by means of micromanipulators under optical control in close proximity to a selected cell [i]. Recently, constant-distance mode → *scanning electrochemical microscopy* was used for positioning of microsensors at the cell without touching the cell membrane [ii]. Depolarization of the membrane using application of high potassium concentrations or addition of specific stimulating agents lead to the fusion of storage vesicles with the cell membrane under release of the neurotransmitter molecules (e.g., dopamine, serotonin etc.) or to the allosteric regulation of enzymes causing the synthesis of the neurotransmitter (NO) which are diffusing through the cell membrane. Detection of the released neurotransmitters by means of constant-potential amperometry or fast-scan cyclic voltammetry allows their quantification as well as the elucidation of release kinetics.

Refs.: [i] a) Wightman RM, Jankowski JA, Kennedy RT, Kawagoe KT, Schroeder TJ, Leszczyszyn DJ, Near Jr JA, Diliberto EJ, Viveros OH (1991) *Proc Natl Acad Sci USA* 88:10754; b) Schroeder TJ, Jankowski JA, Kawagoe KT, Wightman RM, Lefrou C, Amatore C (1992) *Anal Chem* 64:3077; c) Bruns D, Jahn R (1995) *Nature* 377:62; d) Chen GY, Ewing AG (1997) *Crit Rev Neurobiol* 11:59; e) Hochstetler SE, Puopolo M, Gustincich S, Raviola E, Wightman RM (2000) *Anal Chem* 72:489; f) Troyer KP, Heien MLAV, Venton BJ, Wightman RM (2002) *Curr Opin Chem Biol* 6:696; g) Troyer KP, Wightman RM (2002) *J Biol Chem* 277:29101; h) Cans AS, Wittenberg N, Eves D, Karlsson R, Karlsson A, Orwar O, Ewing A (2003) *Anal Chem* 75:4168; i) Wightman RM (2006) *Science* 311:1570; [ii] a) Kashyap R, Gratzl K (1999) *Anal Chem* 71:2814; b) Hengstenberg A, Blöchl A, Dietzel ID, Schuhmann W (2001) *Angew Chem Int Ed Engl* 40:905; c) Liebetrau JM, Miller HM, Baur JE (2003) *Anal Chem* 75:563; d) Pitta Bauermann L, Schuhmann W, Schulte A (2004) *Phys Chem Chem Phys* 6:4003

WSchu

Neutralization — A chemical reaction in which an acid and a base interact with the formation of a salt and water [i].

Ref.: [i] Harris D (2002) *Quantitative chemical analysis*. WH Freeman, New York

FG

Neutron activation → *radiochemical (nuclear) methods in electrochemistry*

NEXAFS — Near-edge extended X-ray absorption fine structure (spectroscopy), evaluation of the X-ray absorption spectrum around and slightly below the absorption edge, for details see → EXAFS.

Refs.: [i] Holze R (2008) *Surface and interface analysis: an electrochemists toolbox*. Springer, Berlin; [ii] Agarwal BK (1991) *X-Ray spectroscopy*. Springer, Berlin; [iii] Tsuji K, Injuk J, Van Grieken R (eds) (2004) *X-Ray spectrometry: recent technological advances*. Wiley, Chichester

RH

Ni–Cd cells — The nickel–cadmium cell is a secondary → *battery* that has a nominal cell potential of 1.20–1.25 V. The negative electrode comprises nickel hydroxide-nickel oxyhydroxide, the positive electrode is cadmium, and the electrolyte solution is based on aqueous potassium hydroxide (KOH, 32% in water). At the anode, the discharge reaction is the oxidation of cadmium metal to cadmium hydroxide with the release of two electrons [i]:

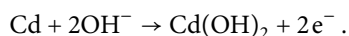

At the cathode, nickel oxyhydroxide is reduced to nickel hydroxide with the acceptance of an electron:

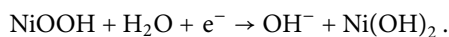

The overall reaction that occurs in a NiCd battery is:

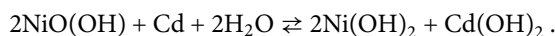

This reaction goes from left to right when the battery is being discharged, and from right to left when it is being recharged. The alkaline electrolyte (KOH) is not consumed in this reaction. In this electrochemical system, the electrodes containing the active materials undergo changes in the oxidation state without pronounced changes in their physical properties. This is because the active materials are highly insoluble in the alkaline electrolyte. An important cell characteristic which results from these chemical and other properties is that the cell voltage is essentially constant throughout most of the discharge. When a cell is overcharged, oxygen and hydrogen gases may be generated at the positive electrode, but the sealed nickel–cadmium cell is designed to accommodate the excess oxygen during slow overcharge with no noticeable loss of performance. This is accomplished by forcing oxygen gas, when formed, to diffuse to the anode and to be reduced there via recombination with hydrogen.

A typical Ni–Cd cell construction is presented in the Figure below [ii]. A cylindrical nickel-plated steel case

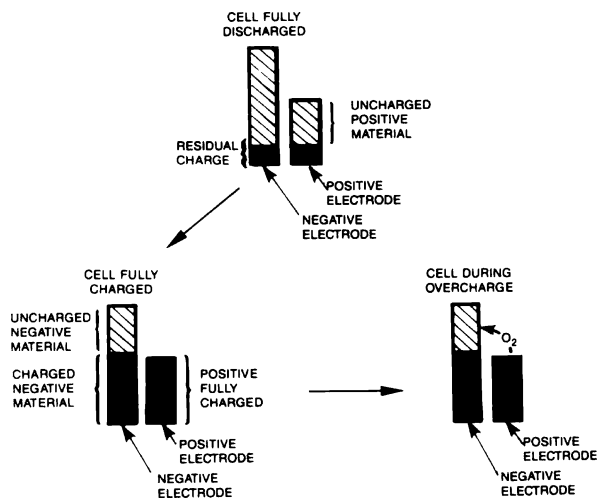

Ni-Cd cell — Figure. nickel-cadmium cell construction

(referred to as the cell can) is used as the negative terminal and the cell cup as the positive terminal. The plates, which are wound to form a compact roll, are isolated from each other by a porous separator, usually nylon, or, in high temperature cells, polypropylene. This separator material, in addition to isolating the plates, contains the electrolyte through which the electrochemical reaction takes place. An insulating seal ring, nylon or polysulfone, electrically isolates the positive cover from the negative can. The battery also contains a resealable vent that employs an elastomer gasket backed by a steel disk and held in place by a helical spring, thus establishing a safety valve. This valve is important for releasing the oxygen formed upon fast charging that may lead to overcharge.

The nickel-cadmium cell is a popular type of rechargeable battery for portable electronics and toys. They are sometimes used as a replacement for primary cells, e.g., heavy-duty, zinc-based alkaline primary batteries. In addition, specialty NiCd batteries have a niche in the market in the area of cordless and wireless telephones, emergency lighting, as well as power tools. Due to their beneficial weight/energy ratio, as compared to lead-based technologies, and their good service lifetimes, nickel-cadmium batteries of large capacities with wet electrolytes (wet NiCds) are used for electric cars and as start batteries for airplanes. Since a nominal Ni-Cd cell potential is lower than the 1.5 V of many popular primary cells, they are not appropriate as replacements in all applications. However, unlike most primary cells, NiCds keep a near-constant voltage throughout their service life. Because many electronic devices are

designed to work throughout the lifetime of the battery, they must operate on voltages as low as 0.9 to 1.0 V per cell, and the 1.2 V of a NiCd is more than enough. In addition, 1.2 V single cells, 7.2, 9.6, and 12 V NiCd batteries made up of several cells connected in series are widely available. NiCd batteries contain cadmium, which is a toxic heavy metal and therefore requires special care during battery disposal. NiCd batteries can be used at temperatures down to -20°C with the standard electrolyte, and down to -50°C with a more concentrated electrolyte. These batteries can also be used at elevated temperatures, up to $45\text{--}50^{\circ}\text{C}$ [iii].

Refs.: [i] Linden D (2002) Basic concepts. In: Linden D, Reddy TB (ed) *Handbook of batteries*. McGraw-Hill, New York, pp 1.3–1.18; [ii] <http://www.rcbatteryclinic.com/seminar.htm>; [iii] Nilsson AO, Baker CA (2002) *Industrial and aerospace nickel-cadmium batteries*. In: Linden D, Reddy TB (ed) *Handbook of batteries*. McGraw-Hill, New York, pp 26.1–26.29

DA, BMa

Nicholson, William

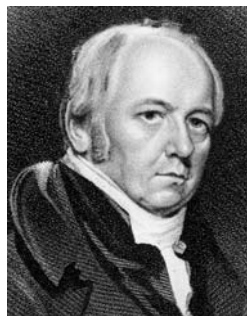

(Science Museum Pictorial)

(1753, London, England – May 21, 1815, Bloomsbury, England) He served as a civil servant at the East India Company before he devoted himself to scientific pursuits and journalism. In 1797 he founded *The Journal of Natural Philosophy, Chemistry and the Arts*, generally known as *Nicholson's Journal*, which he published monthly until 1814.

In 1799 he established a school in London, where he taught natural philosophy and chemistry. In 1800 he and → *Carlisle* constructed a voltaic pile by using half-crown as silver discs (they also used platinum, gold and copper wires) pieces of zinc, pasteboard soaked in salt water, and noticed that gas bubbles were evolved from a drop of water which they used to improve the electrical contact of the leads. They proved that the gases were hydrogen and oxygen, therefore water was decomposed by → *electrolysis*. Nicholson immediately announced the results in his journal, the paper [i] appearing in July, 1800, in advance of → *Volta's* paper.

The results surprised the whole scientific community in two respects: it was the first experiment on the chemical effect of the current, and the decomposition of water which led to the evolution of two different gases at a distance of two inches was a puzzle which initiated further research on the development of theory of electrolysis. (See → Davy, → Grotthus, → Faraday, → Ritter)

During the later years of his life he worked as waterworks engineer and a science writer. In 1808 he compiled a Dictionary of Practical and Theoretical Chemistry [ii, iii].

Refs.: [i] Nicholson W, Carlisle A (1800) *Nicholson's Journal (J Natl Phil Chem Arts)* 4:179; [ii] Laidler KJ (1993) *The World of Physical Chemistry*, Oxford University Press, Oxford, pp 199, 200, 440; [iii] Rieger PH (1994) *Electrochemistry*. Chapman & Hall, New York, p 4

Nickel–cadmium cell → *Ni–Cd cell*

Nickel–iron rechargeable cell → *Edison cell*

Nickel–metal hydride cell → *Ni–MH cell*

Nicotinamide adenine dinucleotide → *NADH*

Nigraniline → *polyaniline*

Nikolskij–Eisenman equation — describes the contribution of interfering ions B, C ... to the potential of an → *ion-selective electrode* which is mainly dominated by the primary ion A. It is an extension of the → *Nernst equation*:

$$E = \text{const.} + \frac{2.303RT}{z_A F} \lg \left[a_A + K_{A,B}^{\text{pot}} a_B^{z_A/z_B} + K_{A,C}^{\text{pot}} a_C^{z_A/z_C} + \dots \right]$$

(*E*: experimentally observed → *emf* of a cell (in V) when the only variables are activities in the test solution, *R* is the → *gas constant*, *T* is the absolute temperature, *F* is the → *Faraday constant*, *a_A* is the activity of the primary ion A, *a_B* and *a_C* are the activities of the interfering ions B and C, *K_{A,B}^{pot}* is the potentiometric → *selectivity coefficient* for ion B with respect to the primary ion A, *z_A* is the charge number of the primary ion A, *z_B* and *z_C* are charge numbers of interfering ions B and C). An ideal ion-selective electrode would exhibit *K_{A,B}^{pot}* = 0. Practical values are between 10⁻¹ and 10⁻⁵.

Refs.: [i] Buck RP, Lindner E (1994) *Pure Appl Chem* 66:2527; [ii] Diamond D, Sáez de Viteri FJ (1998) *Ion-selective electrodes and optodes*.

In: Diamond D (ed) *Principles of chemical and biological sensors*. Wiley, New York, pp 21–26

HK

Ni–MH cell — A → *secondary battery* (→ *accumulator*) containing a nickel hydroxide positive electrode, a metal hydride negative electrode, and a strongly alkaline aqueous electrolyte solution. The electrode reactions are

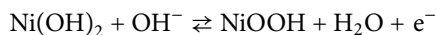

and

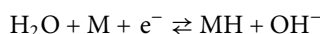

with the cell reaction.

GI Numerous metal hydrides have been examined as possible materials for reversible hydrogen

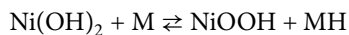

storage, most popular are AB₅ alloys (e.g., LaNi₅). Because of insufficient stability, in particular versus corrosive attack, mixing with other metals like cobalt is applied. The rather expensive pure lanthanum is substituted by mixtures of naturally occurring rare earth metals. This also results in a diminished hydrogen partial pressure inside the cell. Use of porous plates as electrodes wrapped into coils as already established with → *NiCd-batteries* provides rate capabilities of NiMH batteries equal to those of NiCd batteries. → *Self discharge* of NiMH batteries amounts to about 20% per month. It is caused by decomposition of the nickel oxide–hydroxide electrode

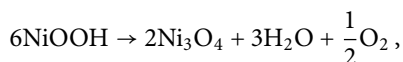

reduction of the nickel oxide electrode by gaseous hydrogen escaping from the metal hydride electrode

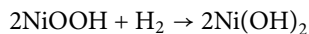

and chemical reactions involving nitrogen-containing impurities

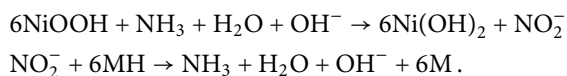

NiMH cells show a significantly reduced memory effect in comparison with NiCd cells.

Because the electrode potential of the cadmium electrode employed in the → *NiCd cell* is rather similar to the

potential of the metal hydride hydrogen electrode used in the NiMH cell the cell voltages of both systems are also very similar, the cells can thus be freely exchanged; this does not apply to charging devices which are different for both systems. The similar discharge curves support the possibility of direct replacement. The maximum cycle number of NiMH cells is larger because the limiting cadmium electrode is replaced by the metal hydride electrode. Because of the slower hydrogen desorption kinetics the NiMH cells are somewhat inferior at low temperatures. The considerable enthalpic effects associated with hydrogen adsorption and desorption during charging and discharging result in larger thermal effects during operation of these cells.

Ref: [i] Linden D, Reddy TB (eds) (2002) *Handbook of batteries*. McGraw-Hill, New York

N

NIR spectroscopy → spectroscopy

Nitrobenzene — Aromatic nitro compound ($C_6H_5NO_2$, M_W 123.1 g mol⁻¹, density 1.2 g cm⁻³ at 20 °C, dielectric constant $\epsilon_r = 35.6$, solubility in water 1.9 g L⁻¹ at 20 °C). Nitrobenzene is a standard solvent for ion-transfer experiments using the 4-electrode technique (see → *ion-transfer at liquid-liquid interfaces*), and also for ion-transfer experiments with immobilized droplets (→ *droplets, electrochemistry of immobilized*).

RH

Noise — (*random*) An unwanted interference of a desired signal. It contains a large number of transient disturbances with a statistically random time distribution. Noise enters a measurement system as a result of intrinsic properties of the electronic system used for detection. The major kinds of noise related to solid-state electronic devices are:

Thermal noise — originates from the thermal agitation of charge carriers (→ *electrons*, → *ions*, etc.) in a → *resistor*. It exists even in the absence of current flow and can be described by the formula: $U_{\text{thermal}} = (4k_B TR\Delta f)^{1/2}$. U_{thermal} is the average amplitude of this noise (also denoted U_{RMS} (or V_{RMS}), see also → *root mean square*), k_B is the → *Boltzmann constant*, R is the → *resistance*, and Δf is the bandwidth of measurement frequencies.

Shot noise — originates from the movement of charge carriers when they cross *n-p* junctions or arrive at an electrode interface. It is much smaller than thermal noise and depends on the signal as follows: $U_{\text{shot}} = R(2Ie\Delta f)^{1/2}$. U_{shot} is the → *root mean square* amplitude

of this noise, R is the → *resistance*, I is the amplitude of the DC current signal, and e is the → *elementary electric charge*. The relative fluctuations associated with this noise are larger for smaller currents [i].

Flicker noise — is common to all solid-state devices and predominates in measurements at frequencies, $f < 300$ Hz. Although the physical origin of this noise is not well understood, it can be described by the following empirical equation: $U_{\text{flicker}} = (KI^2/f)^{1/2}$, U_{flicker} is the → *root mean square* amplitude of this noise, K is a constant depending on factors such as resistor materials and geometry, and I is the DC current [i].

Impulse noise — is an unwanted interference of a signal by random energy spikes having random amplitude and spectral content.

Environmental noise — is related to the transfer of energy from the environment to the measuring system. Although this kind of noise typically occurs at specific frequencies, such as the electric and magnetic fields produced by the electrical transmission lines, environmental sources can also originate from random sources. → *Shielding* the electronic circuits can reduce or eliminate this kind of noise [ii].

Refs.: [i] Horowitz P, Hill W (2001) *The art of electronics*. Cambridge University Press, Cambridge; [ii] Willard HH, Merritt LL, Dean JA, Settle FA (1988) *Instrumental methods of analysis*. Wadsworth, California

FG

RG

Noise analysis — Unlike the usual definition of → *noise*, electrochemical noise (ECN) is a stochastic (or random) fluctuation in signal that arises from fluctuations in the rate of electrochemical reactions. Such fluctuations often result from nonuniform dissolution of a metal substrate (e.g., → *pitting corrosion*), leading to current transients. These current transients, in turn, lead to fluctuations in the metal substrate potential, a consequence of the current passing through the interfacial impedance at the site of dissolution. Measurements of these fluctuations in current and/or potential are referred to as electrochemical noise measurements (or the electrochemical noise method). Electrochemical noise might also arise from → *adsorption/desorption* processes, variations in → *mass transport* rate (e.g., due to variations in boundary layer thickness under turbulent flow conditions) or from bubble nucleation, growth, and detachment (e.g., hydrogen evolution). An advantage of the electrochemical noise method is that the measurement can be performed without applying any external perturbation. As a result, the electrochemical noise method is finding increasing application to the study of corrosion in the laboratory and also to corrosion monitoring of real structures, such as

power plant boilers, transmission line towers, offshore pipelines, nuclear waste storage tanks, etc.

Electrochemical noise measurements may be performed in the potentiostatic mode (current noise is measured), the galvanostatic mode (potential noise is measured), or in the ZRA mode (zero resistance ammeter mode, whereby both current and potential noise are measured under open-circuit conditions). In the ZRA mode, two nominally identical metal samples (electrodes) are used and the ZRA effectively “shorts” them together while permitting the current flow between them to be measured. At the same time, the potential of the coupled electrodes is measured versus a low-noise reference electrode (or in some cases a third identical electrode). The ZRA mode is commonly used for corrosion monitoring.

Electrochemical noise is $1/f$ noise (that is, the power spectral density increases at low frequencies). Thus, most electrochemically generated noise occurs at relatively low frequencies (of the order of 1 Hz and less). The current and potential data are collected in the time domain at a fixed sampling rate (typically 0.1 Hz to several hundred Hz) and for a fixed sampling duration (typically a few tens or hundreds of seconds). The sampling rate and sampling duration determine the highest and lowest limits of frequency, respectively, (i.e., the bandwidth) over which information can be extracted from the data during analysis. The ECN measurement may be repeated periodically to track long-term changes in the system under study.

Although most agree that electrochemical noise contains useful information about electrochemical processes, there is not yet agreement on the best approach to extracting the information from the data. Most noise analysis techniques assume the noise data is stationary, that is, the mean, variance, and autocorrelation structure do not change over time. However, typical current and potential noise data are nonstationary or weakly stationary in character. Often prior to analysis, detrending is performed on the data whereby a straight line or a polynomial fit to the data is obtained and then subtracted from each data point, removing any background drift in voltage and/or current. The ECN data may then be analyzed in the time domain or in the frequency domain.

A common time domain analysis involves computing the standard deviation of the potential (σ_E) and the standard deviation of the current (σ_I) from the time series data and taking their ratio to compute a noise resistance R_N :

$$R_N = \frac{\sigma_E}{\sigma_I}.$$

The value of R_N depends on the bandwidth of the ECN measurement and equals the \rightarrow *polarization resistance* (R_P) only if the ECN and impedance data are independent of frequency within that bandwidth. In such cases, R_N can be used to compute the corrosion rate of a bare metal specimen [i, ii]. For coated metals, the R_N is often used as a measure of coating barrier properties [iii].

More detailed information can be obtained from noise data analyzed in the frequency domain. Both \rightarrow *Fourier transformation* (FFT) and the Maximum Entropy Method (MEM) have been used to obtain the power spectral density (PSD) of the current and potential noise data [iv]. An advantage of the MEM is that it gives smooth curves, rather than the noisy spectra obtained with the Fourier transform. Taking the square root of the ratio of the PSD of the potential noise to that of the current noise generates the “noise impedance” spectrum, $Z_N(f)$, equivalent to the impedance spectrum obtained by conventional \rightarrow *electrochemical impedance spectroscopy* (EIS) for the same frequency bandwidth. The noise impedance can be interpreted using methods common to EIS. A critical comparison of the FFT and MEM methods has been published [iv].

Wavelet analysis is a rather new mathematical tool for the frequency analysis of nonstationary time series signals, such as ECN data. This approach simulates a complex time series by breaking up the ECN data into different frequency components or wave packets, yielding information on the amplitude of any “periodic” signals within the time series data and how this amplitude varies with time. This approach has been applied to the analysis of ECN data [v, vi]. Since electrochemical noise is $1/f$ (or flicker) noise, the new technique of \rightarrow *flicker noise spectroscopy* may also find increasing application.

Refs.: [i] Eden DA, Hladky K, John DG, Dawson JL (1986) *Corrosion* 86, Paper 274, NACE; [ii] Mansfeld F, Xiao H (1993) *J Electrochem Soc* 140:2205; [iii] Bierwagen GP, Tallman DE (2001) *Prog Org Coat* 41:201; [iv] Bertocci U, Frydman J, Gabrielli C, Huet F, Keddah M (1998) *J Electrochem Soc* 145:2780; [v] Aballe A, Bethencourt M, Botana FJ, Marcos M (1999) *Electrochim Acta* 44:4805; [vi] Wharton JA, Wood RJK, Mellor BG (2003) *Corros Sci* 45:97

DT

Noise elimination \rightarrow Noise can be eliminated using either electronic circuits or software procedures. The hardware methods based on simple RC \rightarrow *circuits* can work well in \rightarrow *potentiostats*. More complex circuits may have names such as noise filter, noise jammer, or noise killer. Very helpful in protecting the electrochemical cell from external noise is the application of a \rightarrow *Faraday box* (*cage*). When \rightarrow *smoothing* of data is done with the soft-

ware or hardware tools, to eliminate noise, care is advised as the measured signals can be affected by such procedures.

In some cases the noise can carry some useful information, see → *noise analysis*.

Refs.: [i] Bard AJ, Faulkner LR (2000) *Electrochemical methods*, 2nd edn. Wiley, New York

ZS

NO (nitrogen monoxide) sensors — Nitric oxide (nitrogen monoxide, NO) is involved in many important physiological processes and it has been identified to be the endothelium-derived relaxing factor (EDRF). A deficiency of NO plays a role in hypertension, hyperglycaemia, arteriosclerosis, Parkinson disease, and Alzheimer disease. Conversely, increased NO levels contribute to arthritis, reperfusion injury, and cancer. Thus, it is important to quantify the details of NO production in biological matrices in order to elucidate the physiological and pathological processes related to NO production and release.

Electrochemical NO sensors based on platinized or electrocatalyst-modified electrodes often in combination with a permselective and charged membrane for interference elimination were proposed. Although the catalytic mechanism is still unknown, it can be assumed that NO is coordinatively bound to the metal center of porphyrin or phthalocyanine moieties immobilized at the electrode surface. The coordinative binding obviously stabilizes the transition state for NO oxidation under formation of NO⁺. Typically, sub- μ M concentrations of NO can be quantified using NO sensors enabling the detection of NO release from individual cells.

Refs.: [i] Vallance P, Patton S, Bhagat K, MacAllister R, Radomski M, Moncada S, Malinski T (1995) *Lancet* 346:153; [ii] Bedioui F, Trevin S, Devynck J (1996) *Electroanalysis* 8:1085; [iii] Pontie M, Bedioui F (2000) *Analysis* 28:465; [iv] Bedioui F, Villeneuve N (2002) *Electroanalysis* 15:5; [v] Oni J, Diab N, Radtke I, Schuhmann W (2003) *Electrochim Acta* 48:3349; [vi] Amatore C, Arbault S, Bouton C, Coffi K, Drapier JC, Ghandour H, Tong Y (2006) *Chem Biol Chem* 7:653

WSchu

Nollet, Jean-Antoine



(Nov. 19, 1700, Pimpré, Oise, France – Apr. 25, 1770, Paris, France) Nollet was a French clergyman, experimental physicist, and leading member of the Paris Academy of Science. In 1748 he invented one of the first electrometers, the → *electroscope*, that showed the presence of electric charge using electrostatic attraction and repulsion. In 1745, Nollet developed a theory of electrical attraction and repulsion assuming the existence of a continuous flow of electrical matter between charged bodies. He was the first to apply the name → *Leyden jar* to the first device for storing electricity. Nollet developed and described in his books different kinds of electrostatic machines, mostly electrostatic friction machines popular at that time. In 1750, he demonstrated electrostatic spraying using electrically charged species. Abbé Nollet taught physics to the French royal children. He was a great popularizer of electrical phenomena and often performed experiments for the public, including experiments with electrostatic charging of a human body popular at that time. Nollet contributed many papers about electrical phenomena to ‘Recueil de l’Académie des Sciences’ and ‘Philosophical Transactions of the Royal Society’, and also published several important books on physical and particularly electrical studies [i–iv].

Refs.: [i] Nollet J-A (1738) *Programme d’un cours de physique expérimentale*. Chez P.E.G., Paris; [ii] Nollet J-A (1743) *Leçons de physique expérimentale*. Durand, Paris; [iii] Nollet J-A (1749) *Recherches sur les causes particulières des phénomènes électriques*. Neveu, Paris; [iv] Nollet J-A (1770) *L’art des expériences*. Libraire, Paris

EK

Non-adiabatic (diabatic) process (quantum mechanics) — In quantum mechanics a process is called non-adiabatic (diabatic) if one or more electrons fail to equilibrate with nuclei as they move. In a widely-used extension of this terminology, non-adiabatic electron transfer is said to occur when an electron tunnels out of one electronically non-equilibrated state into another. Due

to the requirement of energy conservation, such tunneling also requires a random fluctuation inside the system to equalize the energies of the two states. In principle, this fluctuation can be provided by any suitable degree of freedom, although it is usually assumed to be due to electrostatic polarization of the reaction center by the motion of one or more nearby solvent molecules.

Unfortunately, the mathematical modeling of non-adiabatic electron transfer requires the solution of the fully time-dependent Schrödinger equation, something generally considered impossible except at the very lowest levels of system complexity. To overcome this difficulty, Paul Dirac (1902–1984) developed a brilliant extension of quantum mechanics called “time-dependent perturbation theory”, which yields good approximate solutions to many practical problems. The only limitation on Dirac’s method is that the coupling (orbital overlap) between the donor states and the acceptor states should be weak [i]. → *Fermi* was so impressed with Dirac’s solution that he famously referred to it as a “Golden Rule”, and the name has stuck [ii]. The Golden Rule formula for the electron transition rate from a near-continuum of donor states to a near-continuum of acceptor states is

$$\langle \lambda_{\text{MDMA}} \rangle \approx \frac{2\pi}{\hbar} \int_{-\infty}^{\infty} \langle |M_{\text{DA}}(E)|^2 \rangle \phi_{\text{DA}}(E) dE$$

where λ_{MDMA} (s^{-1}) is the multiple-donor multiple-acceptor rate constant for electron transfer, \hbar is the reduced Planck constant (1.055×10^{-34} Js), M_{DA} is the coupling energy (matrix element) between the donor and acceptor states (joules), and $\phi_{\text{DA}}(E)$ is the joint density of donor and acceptor states through which electron transfer may occur (joules^{-2}). The term $\langle |M_{\text{DA}}(E_{\text{D}})|^2 \rangle$ denotes the value of $|M_{\text{DA}}(E_{\text{D}})|^2$ averaged over all the paired states, and by “joint density” we simply mean the number of donor states whose energies actually coincide with the energies of acceptor states.

Three landmark papers on the application of time-dependent perturbation theory to electrochemical problems were published in rapid succession by → *Levich* and → *Dogonadze* in 1959 [iii], → *Gerischer* in 1960 [iv], and *McConnell* in 1961 [v]. A very large literature has subsequently sprung from these works, driven by developments in scanning tunneling microscopy, molecular electronics, and biological electron transfer.

See also → *adiabatic process*, → *Marcus theory*, → *Randles*, and → *Gurney*.

Refs.: [i] *Dirac PAM (1927) Proc Roy Soc (Lond) A114:243*; [ii] *Nuclear physics. A course given by Enrico Fermi at the University of Chicago. Notes compiled by Orear J, Rosenfeld AH, and Schluter RA, Univ Chicago*

Press, 1950; [iii] *Levich V, Dogonadze RR (1959) Dokl Akad Nauk SSR 124:123*; [iv] *Gerischer H (1960) Z Physik Chem 26:223*; [v] *McConnell HM (1961) J Chem Phys 35:508*

SF

Nonaqueous electrochemistry — Electrochemistry (both interfacial and ionic) related to solutions other than aqueous solutions. This includes the following solvents, condensed gases, gels, and solids, all ensuring electric conductivity either by self-dissociation or by dissolving the appropriate electrolytic salts:

- Inorganic liquids of a protonic and aprotic nature obtained by the condensation of gases at low temperature and/or high external pressure, e.g., liquid ammonia and SO_2 , respectively;
- Inorganic protonic compounds such as pure H_2SO_4 and oleums containing different amounts of SO_3 ;
- Organic protonic solvents such as methanol, ethanol, etc.;
- Dipolar aprotic organic solvents, e.g., acetonitrile, tetrahydrofurane, dimethylformamide, dimethylsulfoxide, sulfolane, methylene chloride, γ -butyrolactone, etc;
- Ionic liquids, mainly molten salts. These include melts for high-temperature electrochemistry and room temperature molten salts.
- Crystalline solid electrolytes such as α -AgI, β -alumina, NASICON, and LISICON, Li_3N , oxide ion conductors such as yttria-stabilized zirconia, etc;
- Polymeric electrolytes, polymer–salt complexes, and gelled electrolytes, e.g., benzyl sulfonic acid siloxane, polyethylene oxide (imine, succinate)- LiClO_4 , and PVDF gel in THF containing a mixture of Bu_2Mg and AlEtCl_2 , respectively.

Nonaqueous electrochemical systems are used when (i) the electrode under consideration chemically reacts with water, (ii) the required electrolytic salt and/or the active solution species under study is not soluble in water, and (iii) when a wider electrochemical window of the solution electrolyte is required than that of aqueous solutions.

A typical example is the electrochemistry of active metals, e.g., Li electrochemistry. Active metal electrodes react continuously, not only with water and protonic

organic solvents such as alcohols, but also with some dipolar aprotic solvents (such as acetonitrile), which do not result in the formation of protective Li-conducting surface films during the reduction process. Thus, the reversible cycling of lithium electrodes, as well as a vast variety of carbonaceous anodes, is only possible with Li salts dissolved in those dipolar aprotic solvents that ensure the formation of passivating (protective) surface films during reduction of the suitable solvent (e.g., organic carbonates: propylene carbonate, different combinations of ethylene carbonate and dimethyl carbonate, etc.), and/or the salt (e.g., LiPF_6). Crystalline, gelled, and polymeric Li-conducting electrolytes are also suitable for the reversible cycling of Li electrodes.

Mg also reacts with water and alcohol. However, in contrast to Li electrodes, Mg cannot be reversibly cycled in dipolar aprotic solvents in the presence of its simple salts such as MgClO_4 , due to the formation of surface films comprising Mg salts that cannot transport Mg ions (because they are bivalent). The choice of the appropriate electrolytic solution is of crucial importance in this case (vide supra).

Mercury and solid s-p metal electrodes show stable electrochemical behavior in nonaqueous media, in particular in dipolar aprotic solvents. This knowledge was important for the advancement of electrochemical methodology, e.g., the special branch of polarography in nonaqueous systems has emerged. When performing electrochemical experiments in nonaqueous media, special attention should be paid to the reasonable choice of reversible \rightarrow *reference electrodes*.

Studies in nonaqueous dipolar aprotic solvents allowed the elucidation of the complicated role of the solvent nature in determining the \rightarrow *double layer* structure and kinetics of electrochemical reactions. Special attention was paid to the phenomenon of ion \rightarrow *solvation* and its effect on \rightarrow *standard electrode potentials*. Experimental studies of the various electrochemical systems in nonaqueous media greatly contributed to the advancement of the theory of elemental electron-transfer reactions across charged interfaces *via* the so-called energy of solvent reorganization.

Modern technological challenges such as the R&D and the commercialization of high-energy density rechargeable \rightarrow *batteries*, effective ion-conducting membranes, super capacitors, electrochemical organic synthesis, including the synthesis of \rightarrow *conducting polymers*, etc., greatly contributed to the development of nonaqueous electrochemistry.

Refs.: [i] Kolthoff IM (1971) In: Marchon JC (ed) *Nonaqueous electrochemistry*. Butterworth, London; [ii] Kissinger PT, Heineman WR (eds)

(1996) *Laboratory techniques in electroanalytical chemistry*, 2nd edn. Marcel Dekker, New York; [iii] Aurbach D (ed) (1999) *Nonaqueous electrochemistry*. Marcel Dekker, New York

DA, ML

Nonaqueous solvents — Nonaqueous solvents are liquids, relevant for the preparation of solutions other than water. They can be classified in several ways: protic (e.g., alcohols, acids, amines, mercaptans, i.e., having labile protons) vs. aprotic; polar vs. nonpolar (e.g., paraffins, olefins, aromatic derivatives, or benzene); organic (e.g.; esters, ethers, alkylcarbonates, nitriles, amides, sulfones) vs. inorganic (chalcogenides such as SOCl_2 , SO_2Cl_2). Nonaqueous solvents may be superior to water in the following aspects:

1. Dissolving organic and inorganic species which are insoluble in water
2. Compatible with substances which are reactive with water (and other protic liquids such as active metals, highly reducing agents)
3. May be less volatile than water, having a very high boiling point (e.g., cycling alkyl carbonates and esters, polyethers, amides)
4. May have much wider electrochemical windows than water (up to 5 V compared to <2 V for aqueous solutions)

Nonaqueous solvents can form electrolyte solutions, using the appropriate electrolytes. The evaluation of nonaqueous solvents for electrochemical use is based on factors such as \rightarrow *dielectric constant*, \rightarrow *dipole moment*, \rightarrow *donor* and *acceptor number*. Nonaqueous electrochemistry became an important subject in modern electrochemistry during the last three decades due to accelerated development in the field of Li and Li ion \rightarrow *batteries*. Solutions based on ethers, esters, and alkyl carbonates with salts such as LiPF_6 , LiAsF_6 , $\text{LiN}(\text{SO}_2\text{CF}_3)_2$, LiSO_3CF_3 are apparently stable with lithium, its alloys, lithiated carbons, and lithiated transition metal oxides with red-ox activity up to 5 V (vs. Li/Li^+). Thereby, they are widely used in Li and Li-ion batteries. Nonaqueous solvents (mostly ethers) are important in connection with other battery systems, such as magnesium batteries (see also \rightarrow *nonaqueous electrochemistry*).

Refs.: [i] Aurbach D, Weissman I (1999) *Nonaqueous electrochemistry: an overview*. In: Aurbach D (ed) *Nonaqueous electrochemistry*. Marcel Dekker, New York, pp 1–52; [ii] Hamann CH, Hamnett A, Vielstich W (1998) *Electrochemistry*. Wiley-VCH, Weinheim; [iii] Gut-

mann V, Resch G (1995) *Lecture notes on solution chemistry*. World Scientific Publishing, Singapore

DA, EM

Nonfaradaic current → *current*

Nonfaradaic electrochemical modification of catalytic activity → *NEMCA*

Nonlinear optical methods → *spectroscopy*

Nonpolarizable electrode → *ideal nonpolarizable electrode*

Nonrechargeable battery — Single use → *batteries*. Batteries that cannot be recharged, and are, thus, disposed of or sent for recycling after their complete discharge. Among the most common nonrechargeable batteries (or cells) are: alkaline MnO_2 , → *Leclanché*, → *zinc-air* and several types of primary → *lithium batteries*. These are in contrast to secondary (rechargeable) batteries (or cells). Also named “primary battery (cell)”.

Refs.: [i] Crompton TR (2000) *Battery reference book*, 3rd edn. Newnes, Oxford, pp 2/3–2/14; [ii] Linden D (1994) *Basic concepts*. In: Linden D (ed) *Handbook of batteries*, 2nd edn. McGraw-Hill, New York, pp 1.9–1.10; [iii] Nagy Z (ed) (2005) *Online electrochemistry dictionary*, <http://electrochem.cwru.edu/ed/dict.htm>

YG

Nonrecursive filter — A software technique based on calculating the current filtered output (y_n) only from the current and previous input values ($x_n, x_{n-1}, x_{n-2}, \dots$). They are inherently stable and commonly involve easier design and less complications than → *recursive filters*. However, some types of nonrecursive filters require significantly more processing and memory resources than → *recursive filters*. The order of a nonrecursive filter (n) is given by the number of previous inputs used to calculate the current output. There is a set of $(n + 1)$ coefficients, one for each input value, that joins the following filter specifications: filter type (low-pass, band-pass, etc), cut-off, and sampling frequencies, smoothing function (Triangular, Hanning, Hamming, Blackman, Kaiser–Bessel, etc.). Filtered data can be obtained by the convolution of inputs with the set of coefficients [i, ii].

Refs.: [i] Oppenheim AV, Schaffer RW (1999) *Discrete-time signal processing*. Prentice-Hall, New Jersey; [ii] Antoniou A (1993) *Digital filters: analysis, design, and applications*. McGraw-Hill, New York

FG

Nonspecific adsorption → *adsorption*

Nonstationary nucleation → *nucleation*, *subentry* → *nonstationary nucleation*

Nonvolmerian electrode reaction → *volmerian electrode reaction*

Normal electrode potential → *standard potential*

Normal element (cell) → *Galvanic element* of exceptional reproducibility of the cell voltage. Since 1908 the → *Weston normal element* is used as the international standard because it has a higher stability than the → *Clark cell*.

FS

Normal hydrogen electrode → *standard hydrogen electrode*

Normal pulse polarography → *polarography*, *subentry* → *normal pulse polarography*

Normal pulse voltammetry (NPV) — A technique invented in 1958 by → *Barker* in which pulses of increasing amplitude are applied. The pulses always start from the initial potential. The current response is usually sampled at the end of the pulse and then plotted versus pulse potential. In such a way a discrete, digitized curve is obtained. The initial potential is a very important parameter. It determines the electrode surface state before the → *faradaic current* starts to flow. The measurement of the current at the end of the pulse allows for a substantial elimination of the → *charging current* and leads to exposition of the faradaic current of interest. The pulse width is usually in the range of 2–200 ms. In specific applications the pulse time can be either shorter or longer. Originally the technique was designed for the → *dropping mercury electrode*, therefore the primary name of the technique was normal pulse → *polarography*. In the work with solid electrodes it is convenient to apply an as-long-as-possible distance between consecutive pulses (usually up to several seconds). Then the initial conditions are restored at the electrode surface before the application of the next pulse and the theoretical modeling of the transport of the reagents and the products of the electrode reaction is greatly simplified. Under such conditions, and also for the → *static mercury drop electrode*, the wave height can be described by

$$i_d = \frac{nFAD^{1/2}C^*}{\pi^{1/2}t_p^{1/2}},$$

where A is the electrode area, D is \rightarrow *diffusion coefficient*, n is the number of electrons transferred, and t_p is the pulse time.

A very useful property of NPV is the independence of the wave height of the electron transfer rate.

Refs.: [i] Bard A, Faulkner LR (2001) *Electrochemical methods*, 2nd edn. Wiley, New York, pp 278–283; [ii] Stojek Z (2002) *Pulse voltammetry*. In: Scholz F (ed) *Electroanalytical methods*. Springer, Berlin

ZS

Norsk-Hydro process — Electrolytic winning of magnesium from melt electrolysis of MgCl_2 requires a dry salt. Precipitates from aqueous solutions contain considerable amounts of water $\text{MgCl}_2 \cdot 6\text{H}_2\text{O}$. Thermal drying results only in $\text{MgCl}_2 \cdot 2\text{H}_2\text{O}$, further heating yield hydrolysis products according to



In the Norsk-Hydro process dehydration takes place in an atmosphere of HCl, this way the equilibrium is shifted to the left-hand side. Pellets of MgCl_2 are dropped into a furnace kept under HCl wherein they are heated and dehydrated.

Refs.: [i] Zirngiebl E (1993) *Einführung in die Angewandte Elektrochemie*. Salle & Sauerländer, Frankfurt; [ii] Pletcher D, Walsh FC (1993) *Industrial electrochemistry*. Blackie Academic, London; [iii] Dittmeier R, Keim W, Kreysa G, Oberholz A (eds) (2005) *Winnacker-Küchler: Chemische Technik*, vol. 3. Wiley-VCH, Weinheim, p 899

RH

Nuclear magnetic resonance spectroscopy \rightarrow *spectroscopy*

Nucleation — is the commonest mechanism by which first-order \rightarrow *phase transitions* are initiated. The nucleation mechanism involves the creation of domains of a new phase, together with their phase boundaries, somewhere inside an existing system. In many cases the new domains are crystals, in which case the process is also referred to as crystallization. If the phase transition occurs at an electrode, the process is referred to as \rightarrow *electrocrystallization*. When the domains are small, their interfacial excess \rightarrow *Gibbs energy* is a substantial fraction of their total Gibbs energy. As a result, there is a Gibbs energy barrier separating the reactant state from the product state. The magnitude of this barrier depends on domain size, but has a local maximum at a certain critical size. Domains that are comparable in size with this critical size are called nuclei. After the initiation of a nucleation process (typically by changing the \rightarrow *electrode potential*) thermal fluctuations create a steady state

population of nuclei around the critical size. Macroscopic domains then grow out of this seed population. The time delay required to form the seed population is known as the time-lag. Time lags are the signature feature of nucleation processes – all nucleation processes exhibit them. If we denote the solution or ambient phase as phase 1, the electrode as phase 2, and the new phase as phase 3, then we may define three interfacial excess free energy densities between them, namely γ_{12} , γ_{13} , and γ_{23} . The steady state rate of nucleation on the electrode surface may then be written [i]

$$\alpha = \alpha_0 \exp\left(\frac{-4\pi [\gamma_{13} - \gamma_{12} + \gamma_{23}]^2 [2\gamma_{13} + \gamma_{12} - \gamma_{23}]}{3RT [nF\rho_m\eta]^2}\right)$$

where α is the steady state rate of nucleation, α_0 is a constant, R is the \rightarrow *gas constant*, T is the absolute temperature, n is the number of electrons in the total reaction, F is the \rightarrow *Faraday constant*, ρ_m is the molar density of the depositing phase, and η is the \rightarrow *overpotential*. Inspection of the above equation reveals that the steady state rate of nucleation is a highly nonlinear function of both overpotential and interfacial excess free energy density. This accounts for the observation that nucleation rates are different on different parts of electrode surfaces (nucleation rate dispersion), the appearance of long-range order among nucleated crystals (decoration of scratches, defects, etc), and the very poor level of experimental reproducibility between ostensibly identical electrodes. In theory, the equilibrium shape of crystals in solution can be determined from knowledge of their Gibbs energies and their interfacial excess free energy densities. In practice, however, the interfacial excess free energy densities are so dependent on the molecular properties of solvents that the construction of the equilibrium shapes of crystals remains a difficult problem.

Ref.: [i] Deutscher RL, Fletcher S (1990) *J Electroanal Chem* 277:1

SF

Atomistic theory of nucleation — The theory applies to very small clusters, the size n of which is a discrete variable and the process of nucleus formation must be described by means of atomistic considerations. Thus, the thermodynamic barrier $\Delta\tilde{G}(n)$ that has to be overcome in order to form an n -atomic nucleus of the new phase is given by the general formula [i–v]

$$\Delta\tilde{G}(n) = -n\Delta\tilde{\mu} + \tilde{\Phi}(n).$$

Here $\Delta\tilde{\mu}$ is the electrochemical \rightarrow *supersaturation* and $\tilde{\Phi}(n)$ takes into consideration the total energy excess due to the creation of new interfaces when a nucleus appears on the electrode surface. The last quantity is expressed as a difference between the \rightarrow *Gibbs energy* $\tilde{G}(n)$

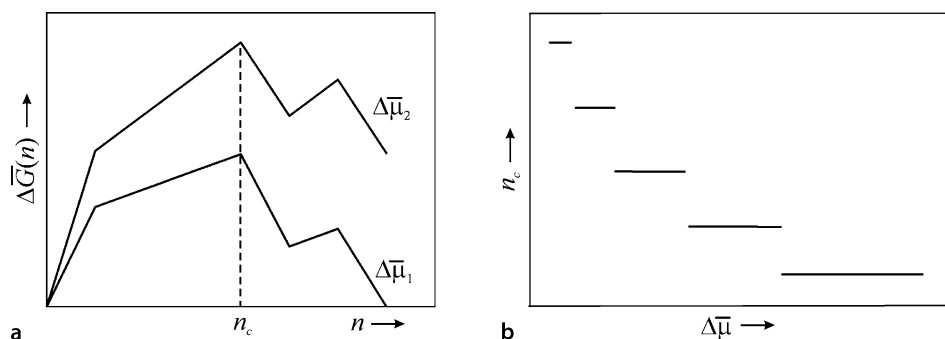

Nucleation — Atomistic theory of nucleation — Figure 1. Dependence of the nucleation work $\Delta\bar{G}(n)$ on the cluster size n (a) and dependence of the critical nucleus size n_c on the supersaturation $\Delta\bar{\mu}$ (b) according to the atomistic nucleation theory (a schematic representation)

of n atoms when they form an individual n -atomic cluster and the Gibbs energy $n\bar{\mu}_\infty$ of the same number of atoms but when they are part of the bulk new phase, its atoms having an \rightarrow electrochemical potential $\bar{\mu}_\infty$,

$$\bar{\Phi}(n) = \bar{G}(n) - n\bar{\mu}_\infty.$$

Note that the quantity $\Delta\bar{G}(n)$ is called also a \rightarrow nucleation work.

The obtained main result of the atomistic treatment is that the $\Delta\bar{G}(n)$ vs. n relationship is not a smooth curve, as in the classical nucleation theory but displays minima and maxima depending on the clusters' structure and energy state (Figure 1a). The highest maximum at a given supersaturation corresponds to the critical nucleus size $n = n_c$. The discrete change of the clusters' size at small dimensions affects also the $n_c(\Delta\bar{\mu})$ relationship (Figure 1b). In this case, to each critical nucleus corresponds a supersaturation interval and not a fixed value of $\Delta\bar{\mu}$ as predicted by the Gibbs–Thomson equation.

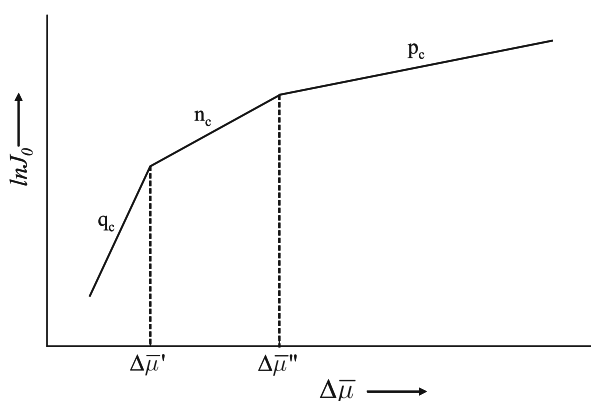

Nucleation — Atomistic theory of nucleation — Figure 2. Supersaturation dependence of the stationary nucleation rate J_0 according to the atomistic theory of nucleus formation (a schematic representation)

Apart from the purely thermodynamic analysis, the description of the \rightarrow electrocrystallization phenomena requires special consideration of the kinetics of nucleus formation [i–v]. Accounting for the discrete character of the clusters' size alteration at small dimensions the atomistic nucleation theory shows that the supersaturation dependence of the stationary nucleation rate J_0 is a broken straight line (Figure 2) representing the intervals of $\Delta\bar{\mu}$ within which different clusters play the role of critical nuclei. Thus, $[\Delta\bar{\mu}', \Delta\bar{\mu}'']$ is the supersaturation interval within which the n_c -atomic cluster is the critical nucleus formed with a maximal thermodynamic work $\Delta\bar{G}(n_c)$.

Refs.: [i] Milchev A, Stoyanov S, Kaischew R (1974) *Thin Solid Films* 22:255, 267; [ii] Milchev A, Stoyanov S (1976) *J Electroanal Chem* 72:33; [iii] Milchev A, Malinowski J (1985) *Surf Sci* 156:36; [iv] Milchev A (1991) *Contemp Phys* 32:321; [v] Milchev A (2002) *Electrocrystallization: fundamentals of nucleation and growth*. Kluwer, Boston

AM

Exclusion zones — Zones of reduced \rightarrow supersaturation in which nucleation of a new phase is fully arrested. Such zones appear around growing stable clusters due to reduced concentration of ionic species and/or reduced \rightarrow overpotential in the clusters' vicinity.

Refs.: [i] Milchev A (1983) *Electrochim Acta* 28:947; [ii] Michailova E, Milchev A (1988) *J Appl Electrochem* 18:614

AM

Instantaneous nucleation — This is the case when all nuclei of the new phase are formed within a short time period after supersaturating the parent phase. Then the nuclei only grow, which means that what we call instantaneous nucleation is the process of growth of a constant number N_0 of supercritical clusters. In this case the theoretical expression for the total \rightarrow current density $j_{N_0}(t)$ reads

$$j_{N_0}(t) = N_0 I_1(t) \quad (1)$$

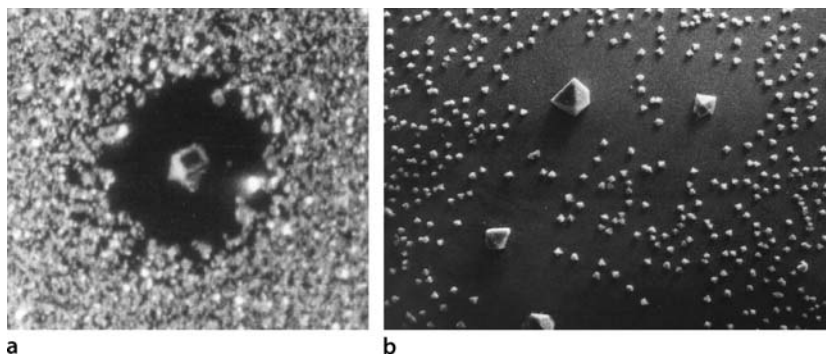

Nucleation — Exclusion zones — Figure. Nucleation exclusion zones formed around growing (a) Ag [i] and (b) Ag₇NO₁₁ single crystals [ii]

N

if the clusters grow independently, $I_1(t)$ being the growth current of an individual cluster. If clusters influence each other during the growth an expression for the current density $j_{N_0}(t)$ can be derived accounting either for direct clusters' coalescence [i–iii] or for overlapping of planar diffusion zones within which nucleation is fully arrested [iv, v]. In the latter case,

$$j_{N_0}(t) = zFc \left(\frac{D}{\pi t} \right)^{1/2} \times \left\{ 1 - \exp \left[-N_0 \pi (8\pi c V_M)^{1/2} D t \right] \right\} \quad (2)$$

In Eq. (2) D is the \rightarrow diffusion coefficient of the ionic species, c is their concentration, and V_M is the molar volume of the deposit.

Refs.: [i] Armstrong RD, Fleischmann M, Thirsk HR (1966) *J Electroanal Chem* 11:208; [ii] Abyaneh MY, Fleischmann M (1981) *J Electroanal Chem* 119:187, 197; [iii] Abyaneh MY (1982) *Electrochim Acta* 27:1329; [iv] Gunawardena G, Hills G, Montenegro I, Scharifker BR (1982) *J Electroanal Chem* 138:225; [v] Scharifker B, Hills G (1983) *Electrochim Acta* 28:879

AM

Non-stationary nucleation

Activation of latent sites — The theory accounts for non-stationary effects due to the appearance and disappearance of active nucleation sites on the electrode surface as a result of chemical and/or electrochemical reactions parallel to the process of nucleus formation. Under such circumstances the time dependence of the number $N(t)$ of nuclei is given by a second-order differential equation:

$$\frac{d^2 N}{dt^2} + A \frac{dN}{dt} + B(N - N_0) = 0 \quad (3)$$

the solution of which yields

$$N(t) = N_0 \left[1 - \frac{A + \lambda - P}{2\lambda} \exp \left(-\frac{A - \lambda}{2} t \right) + \frac{A - \lambda - P}{2\lambda} \exp \left(-\frac{A + \lambda}{2} t \right) \right] \quad (4)$$

Correspondingly, for the nucleation rate $J(t) = dN(t)/dt$ it results

$$J(t) = \frac{N_0 B}{\lambda} \left[\left(1 - \frac{P}{A + \lambda} \right) \exp \left(-\frac{A - \lambda}{2} t \right) - \left(1 - \frac{P}{A - \lambda} \right) \exp \left(-\frac{A + \lambda}{2} t \right) \right] \quad (5)$$

In Eqs. (3)–(5) A , B , and P are kinetic constants depending on the activation, deactivation and nucleation frequencies, $\lambda^2 = A^2 - 4B > 0$ and N_0 is the total number of active sites.

Refs.: [i] Milchev A (1985) *Electrochim Acta* 30:125; [ii] Milchev A (1986) *Electrochim Acta* 31:977; [iii] Milchev A (1998) *J Electroanal Chem* 457:35, 47; [iv] Milchev A (2002) *Electrocrystallization: fundamentals of nucleation and growth*. Kluwer, Boston

AM

Zel'dovich theory — The theory determines the time dependence of the nucleation rate $J(t) = dN(t)/dt$ and of the number $N(t)$ of nuclei and derives a theoretical expression for the induction time τ needed to establish a stationary state in the supersaturated system. The \rightarrow Zel'dovich approach [i] (see also [ii]) consists in expressing the time dependence of the number $Z(n, t)$ of the n -atomic clusters in the supersaturated parent phase by means of a partial differential equation:

$$\frac{\partial Z(n, t)}{\partial t} = \frac{\partial}{\partial n} \left\{ \omega_+(n) Z_e(n) \frac{\partial}{\partial n} \left[\frac{Z(n, t)}{Z_e(n)} \right] \right\} \quad (6)$$

in which

$$J(n, t) = -\omega_+(n)Z_e(n) \frac{\partial}{\partial n} \left[\frac{Z(n, t)}{Z_e(n)} \right] \quad (7)$$

is the nonstationary nucleation rate, ω_{+n} is the frequency of attachment of single atoms to the n -atomic clusters, and $Z_e(n)$ is their number at equilibrium. As \rightarrow Zel'dovich pointed out, in a particular case of constant $Z_e(n)$, i.e., when all points of the size axis are equivalent as in the case of the motion of particles in a space with exterior forces absent, Eq. (6) transforms into the \rightarrow Fick's law:

$$\frac{\partial Z}{\partial t} = \omega \frac{\partial^2 Z}{\partial n^2} \quad (8)$$

where ω plays the role of a diffusion coefficient [i].

An exact solution of Eq. (6) cannot be obtained. However, different approximate expressions have been derived for $J(t)$, $N(t)$, and τ [ii-x], the latter being presented as

$$\tau = \frac{1}{a\Gamma^2\omega_{+n_c}} \quad (9)$$

where Γ is the so-called factor of Zel'dovich and $a = 4\pi^2$ according to [vi], $a = \pi^3/4$ according to [viii], $a = 6.4 \pm 0.4$ according to [xi].

Refs.: [i] Zel'dovich YB (1943) *Acta Physikokhim USSR* 18:1; [ii] Frenkel YI (1955) *Kinetic theory of liquids*. Dover, New York; [iii] Probstein RF (1951) *J Chem Phys* 19:619; [iv] Kantrowitz A (1951) *J Chem Phys* 19:1097; [v] Wakeshima H (1954) *J Chem Phys* 22:1614; [vi] Collins FC (1955) *Z Electrochem* 59:404; [vii] Chakraverty BK (1966) *Surface Sci* 4:205; [viii] Kashchiev D (1969) *Surface Sci* 14:209; [ix] Binder K, Stauffer D (1976) *Adv Phys* 25:343; [x] Roldigin VI, Danilov AI, Polukarov YuM (1985) *Elektrokhimiya* 21:661; [xi] Isaev VA, Volegov AV, Baraboshkin AN (1989) *Rasplavi* 3:114

AM

Probabilistic approach to nucleation — Basic stochastic properties of assemblies of clusters randomly distributed in space or appearing in time as a nonstationary flux of random independent events can be examined in terms of the Poisson theory [i]. See \rightarrow temporal distribution of clusters \rightarrow spatial distribution of clusters.

Ref.: [i] Poisson SD (1837) *Recherches sur la Probabilité des Judgment*. Paris

AM

Progressive nucleation — If nuclei of the new phase form, grow and overlap during the whole period of observation the nucleus formation is considered as a progressive process. Then the current density $j_N(t)$ of

progressive nucleation is obtained by solving the general convolution integral [i-iii]

$$j_N(t) = \int_0^t J(u) [1 - \theta(u)] I_1(t - u) du. \quad (10)$$

Here $I_1(t - u)$ is the growth current of a single cluster born at time $t = u$, $[1 - \theta(u)]$ is the actual free surface fraction available for the nucleus formation, and $J(u)$ is the nucleation rate at time $t = u$. Similarly to the case of \rightarrow instantaneous nucleation an expression for the current density $j_N(t)$ can be derived accounting either for direct clusters' coalescence [iii-vi] or for overlapping of planar diffusion zones within which nucleation is fully arrested [vii-xi]. In the latter case,

$$j_N(t) = \frac{4}{3} zFc \left(\frac{D}{\pi t} \right)^{1/2} \left\{ 1 - \exp \left[-\frac{1}{2} J_0 \pi (8\pi c V_M)^{1/2} D t^2 \right] \right\}. \quad (11)$$

In Eq. (10) D is the \rightarrow diffusion coefficient of the ionic species, c is their concentration, J_0 is the stationary nucleation rate, and V_M is the molar volume of the deposit.

Refs.: [i] Fleischmann M, Thirsk HR (1959) *Electrochim Acta* 1:146; [ii] Fleischmann M, Thirsk HR (1963) *J Electrochem Soc* 110:688; [iii] Thirsk HR, Harrison JA (1972) *A guide to the study of electrode kinetics*. Academic Press, London; [iv] Armstrong RD, Fleischmann M, Thirsk HR (1966) *J Electroanal Chem* 11:208; [v] Abyaneh MY, Fleischmann M (1981) *J Electroanal Chem* 119:187, 197; [vi] Abyaneh MY (1982) *Electrochim Acta* 27:1329; [vii] Gunawardena G, Hills G, Montenegro I, Scharifker BR (1982) *J Electroanal Chem* 138:225; [viii] Scharifker B, Hills G (1983) *Electrochim Acta* 28:879; Scharifker BR, Mostany J (1984) *J Electroanal Chem* 177:13; [ix] Sluyters-Rehbach M, Wijenberg JHOJ, Bosco E, Sluyters JH (1987) *J Electroanal Chem* 236:1; [x] Mirkin MV, Nilov AP (1990) *J Electroanal Chem* 283:35; [xi] Heerman L, Tarallo A (1998) *J Electroanal Chem* 451:101

AM

Stochastic approach to nucleation — Basic stochastic properties of assemblies of clusters randomly distributed in space or appearing in time as a nonstationary flux of random independent events can be examined in terms of the Poisson theory [i]. See \rightarrow temporal distribution of clusters \rightarrow spatial distribution of clusters.

Ref.: [i] Poisson SD (1837) *Recherches sur la Probabilité des Judgment*. Paris

AM

Spatial distribution of clusters — The general theoretical expression for the probability distribution function $dP_{\nu,n}$ of the distances between

n th neighbor clusters randomly located within a ν -dimensional space is given by [i–iv]:

$$dP_{\nu,n} = \frac{\nu}{(n-1)!} \left[\frac{\pi^{\nu/2} N_{0,\nu}}{\Gamma(1+\nu/2)} \right]^n \quad (12)$$

$$r_{\nu,n}^{\nu n-1} \exp \left[-\frac{\pi^{\nu/2} N_{0,\nu} r_{\nu,n}^{\nu}}{\Gamma(1+\nu/2)} \right] dr_{\nu,n} \quad (13)$$

In fact $dP_{\nu,n}$ is the probability for a given cluster to have its n th neighbor in a distance between $r_{\nu,n}$ and $r_{\nu,n} + dr_{\nu,n}$ if $N_{0,\nu}$ is the average cluster density, Γ is the gamma function, and ν is the space dimension. $\nu = 1$ if clusters are formed on a step, $\nu = 2$ if clusters are formed on a surface, and $\nu = 3$ if clusters are incorporated within a three-dimensional matrix, e.g., within the bulk of an electrically conducting medium. Correspondingly, the average distance $\bar{r}_{\nu,n}$ between clusters is defined as

$$\bar{r}_{\nu,n} = \int_0^{\infty} r_{\nu,n} dP_{\nu,n} = \frac{\Gamma(n+1/\nu)}{(n-1)! (\kappa_{\nu} N_{0,\nu})^{1/\nu}} \quad (14)$$

Figure illustrates the correlation between the experimental (histograms) and theoretical (lines) distributions of the distances between first, second, and third neighbor silver crystals electrodeposited on a mechanically polished glassy carbon electrode [v]. It shows that the experimentally measured smallest distances appear with a probability lower than the theoretically predicted for a random distribution, the effect being less pronounced for second and for third neighbor clusters. The reason is that nucleation \rightarrow exclusion zones arise around the growing stable clusters. Deviations from the random distribution were experimentally registered also in other electrochemical systems [vi–xi] and were confirmed by means of computer simulations, too [xii, xiii].

Refs.: [i] Hertz P (1909) *Math Ann* 67:387; [ii] Chandrasekhar S (1943) *Rev Mod Phys* 15:1; [iii] Milchev A (1994) *J Chem Phys* 100:5160;

[iv] Milchev A (2002) *Electrocrystallization: fundamentals of nucleation and growth*. Kluwer, Boston; [v] Milchev A, Michailova E, Lesigiraska I (2000) *Electrochem Commun* 2:407; [vi] Kruijt WS, Sluyters-Rehbach M, Sluyters JH, Milchev A (1994) *J Electroanal Chem* 371:13; [vii] Mostany J, Serruya A, Scharifker BR (1995) *J Electroanal Chem* 383:33; [viii] Serruya A, Scharifker BR, Gonzalez I, Oropeza MT, Palomar-Pardave M (1996) *J Appl Electrochem* 26:451; [ix] Schmidt U, Donten M, Osteryoung JG (1997) *J Electrochem Soc* 144:2013; [x] Serruya A, Mostany J, Scharifker BR (1999) *J Electroanal Chem* 464:39; [xi] Ivanov S, Tsakova V (2002) *J Appl Electrochem* 32:709; [xii] Milchev A, Kruijt WS, Sluyters-Rehbach M, Sluyters JH (1993) *J Electroanal Chem* 362:21; [xiii] Tsakova V, Milchev A (1998) *J Electroanal Chem* 451:211

AM

Temporal distribution of clusters —

In the initial stage of the first-order \rightarrow phase transitions, the appearance of nuclei on the electrode surface can be considered as a flux of random independent events along the time axis. Therefore, the probability P_m to form exactly m nuclei within a time interval $[0, t]$ can be expressed by the Poisson distribution law:

$$P_m = \frac{N^m \exp(-N)}{m!} \quad (15)$$

where $N(t)$ is the expected average number of nuclei within $[0, t]$. Thus the probability P_0 to form $m = 0$ nuclei is $P_0 = \exp(-N)$, the probability to form exactly 1 nucleus ($m = 1$) is $P_1 = N \exp(-N)$ etc.

Correspondingly, the probability $P_{\geq m}$ to form at least m , i.e., m or more than m , nuclei within the interval $[0, t]$ is given by:

$$P_{\geq m} = 1 - P_0 - P_1 - P_2 - \dots - P_{m-1} = 1 - \exp(-N) \sum_{i=0}^{m-1} \frac{N^i}{i!} \quad (16)$$

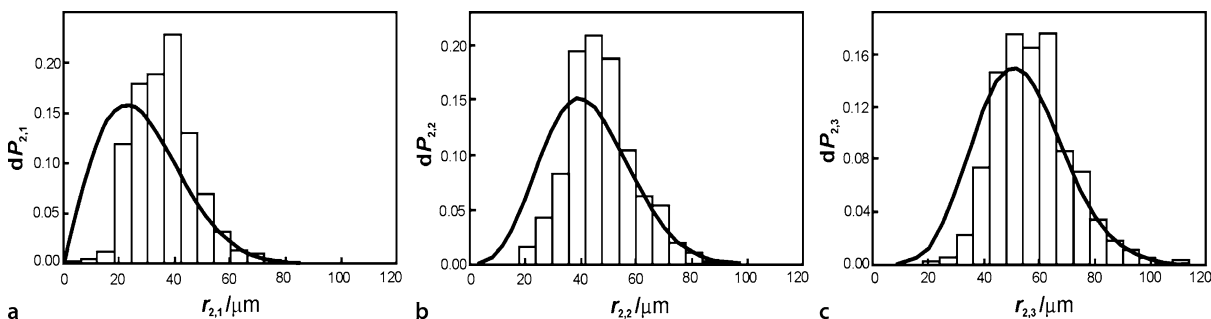

Nucleation — Stochastic approach to nucleation — Spatial distribution of clusters — Figure. Experimental (histograms) and theoretical (lines) distribution of the distances between first (a), second (b) and third (c) neighbor silver crystals electrochemically deposited on a glassy carbon electrode [iii–v]

whereas for the probability $dP_{\geq m}$ to form the m th nucleus within the infinitesimal time interval $[t, t + dt]$ it results:

$$dP_{\geq m} = \frac{N^{m-1} \exp(-N) dN}{(m-1)! dt} \quad (17)$$

Thus, the average time \bar{t}_m of expectation is defined as:

$$\bar{t}_m = \int_0^{\infty} t dP_{\geq m} \quad (18)$$

For the special case $m = 1$, Eq. (16) transforms into $P_{\geq 1} = 1 - \exp(-N)$, which gives the probability of formation of at least one nucleus within the time interval $[0, t]$ and is a very frequently studied stochastic quantity.

The probabilities $P_{\geq m}$, $dP_{\geq m}$, and the average time of expectation \bar{t}_m contain essential information on the most important kinetic characteristics of the nucleation process: the nucleation rate $J(t) = dN(t)/dt$ and the average number of nuclei $N(t) = \int_0^t J(t) dt$. If the nucleus formation takes place with a stationary rate J_0 then $N(t) = J_0 t$ and Eq. (18) integrates to $\bar{t}_m = m/J_0$. In the particular case of $m = 1$, the average time of expectation becomes $\bar{t}_1 = 1/J_0$.

Refs.: [i] Toshev S, Milchev A, Stoyanov S (1972) *J Crystal Growth* 13/14:123; [ii] Gunawardena, GA, Hills GJ, Scharifker BR (1981) *J Electroanal Chem* 130:99; [iii] Milchev A, Tsakova V (1985) *Electrochim Acta* 30:133; [iv] Milchev A (2002) *Electrocrystallization: fundamentals of nucleation and growth*. Kluwer, Boston

AM

Nucleation overpotential — In 1898 → *Haber* showed that different reaction products could be obtained at different → *electrode potentials*, using the reduction of nitrobenzene as an example [i]. However, a further forty four years would elapse before the invention of the → *potentiostat* by Hickling (1942), which finally made the control of the electrode potential routine [ii]. In the interim, a tradition developed of describing the mechanisms of electrode reactions in terms of current as input and “overpotential” as output. The culmination of this tradition was Vetter’s magnum opus of 1961 which summarized much of the theory of → *overpotentials* [iii]. Today, the use of overpotentials survives only in certain specialist applications, such as in metal plating, where nucleation overpotentials continue to be routinely measured. The relation between the rate of nucleation of bulk crystals and overpotential was first derived in 1931 by → *Erdey-Gruz* and

→ *Volmer* [iv]. In modern terminology the result is given by Fletcher [v] as

$$\alpha = a_0 \exp\left(\frac{-4\pi [\gamma_{13} - \gamma_{12} + \gamma_{23}]^2 [2\gamma_{13} + \gamma_{12} - \gamma_{23}]}{3RT [nF\rho_m\eta]^2}\right)$$

or

$$\ln \alpha = \ln a_0 - \frac{const}{\eta^2}.$$

Here we denote the solution or ambient phase as phase 1, the electrode as phase 2, and the new phase as phase 3. The three interfacial excess free energy densities between them are γ_{12} , γ_{13} , and γ_{23} , and α is the steady state rate of nucleation. In addition, a_0 is a constant, R is the → *gas constant*, T is the absolute temperature, n is the number of electrons in the total reaction, F is the → *Faraday constant*, ρ_m is the molar density of the depositing phase, and η is the overpotential.

Refs.: [i] Haber F (1898) *Z Electrochem* 4:506; [ii] Hickling A (1942) *Trans Faraday Soc* 38:27; [iii] Vetter KJ (1967) *Electrochemical kinetics: theoretical and experimental aspects*. Academic Press, New York, 1967; [iv] Erdey-Gruz T, Volmer M (1931) *Z phys Chem A* 157:165; [v] Fletcher S (1990) *J Electroanal Chem* 277:1

SF

Nucleation and growth kinetics — Nucleation-and-growth is the principal mechanism of phase transformation in electrochemical systems, widely seen in gas evolution, metal deposition, anodic film formation reactions, and polymer film deposition, etc. It is also seen in solid-state phase transformations (e.g., battery materials). It is characterized by the complex coupling of two processes (nucleation and phase growth of the new phase, typically a crystal), and may also involve a third process (diffusion) at high rates of reaction. In the absence of diffusion, the observed electric current due to the nucleation and growth of a large number of independent crystals is [i]

$$I = \int_0^t I_1(\tau, t) N'(\tau) d\tau$$

here I_1 is the current flowing into one crystal nucleated at time τ and observed at time t , $N(t)$ is the number of crystals at time t , and $N'(t)$ is the observed nucleation rate (appearance rate) of crystals. The superscript “primed” indicates the first derivative of N with respect to time t . The above expression for the electrical current is a Volterra integral equation of the first kind.

This equation generates a number of distinctive features that are useful for diagnosing nucleation-growth kinetics, most notably a nucleation-growth loop in \rightarrow *cyclic voltammetry* [ii] a U-shaped potential-time curve in \rightarrow *chronamperometry* [iii], and an inductive loop in the complex plane of \rightarrow *impedance* [iv]. At constant potential, the Volterra integral may be replaced by a convolution integral, allowing simplified models to be derived, usually based on polynomial approximations for $N'(t)$ and $I_1(t)$. Often, the current flowing into one crystal is wholly determined by the rate of ion transfer at the crystal surface. But when diffusion intervenes, the mathematical analysis generally becomes intractable. One exception is the current-time behavior for the growth of a single nucleus at which hemispherical diffusion is coupled with a reversible, first-order ion transfer reaction. The result is then [v]

$$I_1 = 2\pi nFD C_b \left[1 - \exp\left(\frac{-nF}{RT}\eta\right) \right] \left[\frac{r^2}{r + D/k_f} \right]$$

$$r = \left(\left[\frac{D}{k_f} \right]^2 + \frac{2DC_b t}{\rho_m} \left[1 - \exp\left(\frac{-nF}{RT}\eta\right) \right] \right)^{1/2} - \frac{D}{k_f}$$

where n is the number of electrons transferred, F is the \rightarrow *Faraday constant*, D is the \rightarrow *diffusion coefficient* of the diffusing species, C_b is the bulk concentration of the diffusing species, R is the \rightarrow *gas constant*, T is the absolute temperature, η is the \rightarrow *overpotential*, r is the radius of the hemispherical nucleus at time t , k_f is the rate constant of the ion transfer reaction, and ρ_m is the molar density of the material composing the nucleus. In the case of multiple nucleation, the simplest possible solution to the Volterra integral equation for the total current arises in the case of so-called progressive nucleation confined to a monolayer. Then $I_1 \approx at$ and $N(t) \approx bt$, so that $I \approx abt^2/2$. The characteristic result is an electric current that rises as the square of time.

Refs.: [i] Fletcher S (1984) *J Electrochem Soc* 131:251; [ii] Fletcher S, Halliday CS, Gates D, Westcott M, Lwin T, and Nelson G (1983) *J Electroanal Chem* 159:267; [iii] Hasse U, Fletcher S, Scholz F (2006) *J Solid State Electrochem* 10:833; [iv] Fletcher S, unpublished results; [v] Fletcher S (1983) *J Chem Soc Faraday Trans I* 79:467

Nucleophile \rightarrow electrophile

Nujol — Mineral oil that is frequently used as binder for graphite \rightarrow *paste electrodes*. Colorless liquid, boiling point: 179–210 °C, specific density: 0.752 g cm⁻³, vapor pressure: 2 psi at 21.2 °C. CAS No: 8020-83-5.

SF
FS

Nürnberg, Hans Wolfgang



(Reprinted from *J. Electroanal Chem.* 214(1986), Copyright (1986), with permission from Elsevier)

(March 18, 1930, Cologne, Germany – May 12, 1985). From 1951–56 Nürnberg studied chemistry in Cologne and Bonn where he made his Ph.D. with \rightarrow *Stackelberg*. After 2 years at the Max-Planck Institute for Iron Research he joined the KFA (Kernforschungsanlage/Nuclear Research Facility) Jülich. In 1962–63 he worked at the Atomic Energy Research Establishment at Harwell, UK, with \rightarrow *Barker*. At the beginning of his career Nürnberg published on \rightarrow *catalytic hydrogen evolution* (waves), and since his stay with Barker he was an enthusiastic user of modern techniques of \rightarrow *voltammetry*, especially \rightarrow *differential pulse voltammetry*. Since 1968 Nürnberg was Director of the Central Institute of Analytical Chemistry of KFA, in 1967 he became Privatdozent, and in 1971 Professor at the University of Bonn, a position which he held parallel to his KFA position. Nürnberg was an extraordinarily gifted organizer of research and together with his many co-workers and cooperation partners he developed numerous electroanalytical methods for the determination of environmentally hazardous compounds.

Ref.: [i] *Obituary: Kastening B, Dürbeck HW, Valenta P (1986) J Electroanal Chem* 214:1

FS

Nusselt number — The Nusselt number (Nu) is used to represent the dimensionless temperature gradient at a surface where heat transfer occurs by convection. This dimensionless parameter may be defined as:

$$Nu = hL/k_f$$

where h is the convective heat transfer coefficient, L the characteristic length, and k_f the thermal conductivity of the fluid. The Nusselt number is a function of the \rightarrow *Reynolds number*, the \rightarrow *Prandtl number*, and when a fluid is at the thermal entry region, the Nusselt number

can vary as a function of the characteristic length. The Nusselt number is used extensively in studies of electrochemical mass transfer [i].

Ref.: [i] Goldstein R, Fleischer AS, Hogerton PB (2001) *J Heat Transfer* 123:1015

AF

Nyquist diagram — The set of values for the frequency dependence of the complex \rightarrow impedance, $Z(f)$, is often presented in the form of a graph in the complex-impedance plane, i.e., as $-Z'' = -\text{Im}Z$ (imaginary part of Z) vs $Z' = \text{Re}Z$ (real part of impedance). For numerous systems this graph looks as a single or several loops (usually, distorted or depressed semicircles) along the x -axis within the 1st quadrant, each loop corresponding to a particular interval of frequencies, i.e., being related to a process (or several processes) with the characteristic time about f^{-1} .

Refs.: [i] Bard AJ, Faulkner LR (2001) *Electrochemical methods*, 2nd edn. Wiley, New York; [ii] Retter U, Lohse H (2005) *Electrochemical impedance spectroscopy*. In: Scholz F (ed) *Electroanalytical methods*. Springer, Berlin, chap II.5.; [iii] Barsoukov E, Macdonald JR (ed) (2005) *Impedance spectroscopy. Theory, experiment, and applications*. Wiley, Hoboken

MAV

Nyquist's frequency — The minimum frequency necessary for accurate sampling of a signal. It must be greater than twice the maximum frequency component in the signal. Thus, \rightarrow aliasing of data is avoided [i].

Ref.: [i] Horowitz P, Hill W (2001) *The art of electronics*. Cambridge University Press, Cambridge

FG

Nyquist's theorem \rightarrow aliasing, and \rightarrow Nyquist's frequency.

O

Occlusion — A type of \rightarrow *coprecipitation* in which a contaminant species is trapped within the growing crystal. The amount of occluded material is greatest in the part of a crystal that forms first [i]. Occlusion of organic additives can occur in \rightarrow *electrodeposition*, e.g., incorporation of cumarin in nickel [ii].

Refs.: [i] Skoog D, West D, Holler F (1996) *Fundamentals of analytical chemistry*. Saunders College Publishing, New York; [ii] Pauvonic M, Schlesinger M (2006) *Fundamentals of electrochemical deposition*, 2nd edn. Wiley, New York, p 194

FG

Ohm, Georg Simon



(Courtesy of Georg-Simon-Ohm-Fachhochschule Nürnberg)

(Mar. 16, 1789, Erlangen, Germany – July 6, 1854, Munich, Germany) Ohm was a German physicist who studied fundamental principles of electricity and electromagnetism [i, ii]. He discovered the law, named after him Ohm's law, which states that the current (I) flowing through a \rightarrow *conductor* is directly proportional to the potential difference (voltage, U) and inversely proportional to the resistance (R): $I = U/R$ (Ohm equation) [iii]. The \rightarrow *resistance* unit Ohm (SI) was named after him.

Refs.: [i] Pourprix B (1995) *Arch Int Hist Sci* 45:30–56; [ii] Jungnickel C, McCormmach R (1986) *Intellectual mastery of nature: theoretical physics from Ohm to Einstein*. University of Chicago Press, Chicago; [iii] Ohm GS (1827) *Die galvanische Kette: mathematisch bearbeitet* (The Galvanic circuit investigated mathematically). Riemann, Berlin

EK

Ohmic contact — In semiconductor science the term 'ohmic contact' designates a metal or silicide contact to

a \rightarrow *semiconductor* with a small interfacial \rightarrow *resistance*. In the strict sense, ohmic characteristic applies only to the observation of a linear dependence between current I and applied \rightarrow *voltage* U . But in practice, contacts are usually denominated ohmic if the contact resistance is low compared to the resistance of the device to be contacted, even if the $I(U)$ characteristics are not linear. A satisfactory ohmic contact should not significantly perturb the device performance. An important figure of merit for ohmic contacts is its contact resistance at zero bias. The contact resistance is defined as the reciprocal of the derivative of the \rightarrow *current density* with respect to applied voltage, $R_c \equiv \left(\frac{\partial I}{\partial U} \right)^{-1} \Big|_{U=0}$

Refs.: [i] Ng KK (2002) *Complete guide to semiconductor devices*. Wiley, New York; [ii] Sze SM (1981) *Physics of semiconductor devices*. Wiley, Singapore

IH

Ohmic drop distortion — Distortion of an electrochemical response caused by uncompensated ohmic resistance (see: $\rightarrow IR_u$ (*ohmic potential*) *drop*).

AMB

Ohmic polarization \rightarrow *ohmic overpotential*

Ohmic resistance behavior — A system obeying \rightarrow *Ohm's law* (the voltage equals the product of \rightarrow *current* and \rightarrow *resistance*, $U = IR$) is said to exhibit ohmic resistance behavior. The electrical resistance R of an ohmically behaving device or element is constant and does not depend on the magnitude of the current or applied \rightarrow *voltage* U , i.e., the differential or incremental resistance defined as $R = dU/dI$ has to be constant. The electrical resistance R is equivalent to the differential resistance only for true ohmic resistance behavior. If the $U - I$ function is not monotonic (i.e., it has a maximum or minimum), the differential resistance will be negative for some values of voltage and current. This property is called negative differential resistance. No real device demonstrates ideal ohmic resistance behavior, but for a wide variety of materials and conditions, many devices approximate it closely, including resistors, pieces of \rightarrow *metal wire*, light bulbs, and \rightarrow *electrolyte solutions*, whereas \rightarrow *charge transfer resistance* is non-ohmic. In \rightarrow *semiconductor* devices, highly doped regions (\rightarrow *ohmic contacts*) approximate ohmic responses even though moderately doped regions are strongly dependent on voltage. The electric resistance of a typical metal conductor increases linearly with the temperature:

$R = R_0 + aT$, whereas that of a typical semiconductor decreases exponentially with the temperature: $R = R_0 + e^{(a/T)}$.

Ref.: [i] Cutnell JD, Johnson KW (2003) *Physics*. Wiley, New York

MHer

Ohmic overpotential — The deviation of the applied \rightarrow potential or the \rightarrow voltage measured in an electrochemical system under conditions of \rightarrow current passage due to solution \rightarrow resistance. Whenever current passes through an electrochemical system, the voltage measured or applied suffers deviation from the equilibrium value due to several factors. The main factors are \rightarrow concentration polarization, \rightarrow activation polarization, and ohmic overpotential, which is also called “ohmic polarization”. In the case of ohmic overpotential, the voltage difference amounts to $\Delta U = IR$, in which I and R denote the current and the solution resistance, respectively. Regardless of the system, (a \rightarrow battery, an \rightarrow electrolysis cell, or a three-electrode electroanalytical system) ohmic overpotential always lowers the actual biased or measured potential (its absolute value). In cases where very large currents are employed, ohmic overpotentials can also be caused due to the conductors (wires, contacts) resistance. Moreover, electrodes made of materials of low electronic conductivity, e.g., composite electrodes, can also develop ohmic overpotentials due to the electronic resistance within the electrode mass. These come in addition to the solution ohmic overpotential. Occasionally, initially electronically conducting electrodes develop insulating surface films as a result of chemical or electrochemical reaction, or due to adsorption. In such cases an ohmic overpotential would also be developed.

Ohmic overpotential is also named \rightarrow IR drop, resistance overpotential, or ohmic drop.

Refs.: [i] Broadhead J, Kuo HC (1994) *Electrochemical principles and reactions*. In: Linden D (ed) *Handbook of batteries*, 2nd edn. McGraw-Hill, New York, p 2.1, Appendix A, p A 7; Gellings PJ, Bouwmeester HJM (eds) (1997) *The CRC handbook of solid state electrochemistry*. CRC Press, p 450; [ii] Zoltan N (1990) *DC relaxation techniques for the investigation of fast electrode reactions*. In: Bockris JO'M, Conway BE, White RE (eds) *Modern aspects of electrochemistry*, vol. 21. Plenum Press, New York, p 244

YG

Ohm's law — One of the most fundamental laws of electric circuits that linearly relates the \rightarrow current passing through a system to the \rightarrow potential across it, with the proportional factor of \rightarrow resistance. It has the form: $I = U/R$, where I is the electric current (in amperes), U is the potential difference (in volts), and R is the re-

sistance (in ohms). Resistance should have positive values. It was first formulated by \rightarrow Ohm in 1826. Systems obeying Ohm's law are called “linear”, whereas the other systems are termed “non-ohmic”, “active”, or “nonlinear”. For instance, the I/U characteristic of \rightarrow semiconductors usually is nonlinear (where R is a function of U). Relatively “negative” values of R (negative slopes of I vs. U) are sometimes observed for redox systems, certain semiconductor types (tunnel/Esaki diodes or Gunn diodes), and discharge lamps. The I vs. U dependencies observed for reversible or quasireversible redox systems (see \rightarrow reversibility), when recorded at sufficiently high polarization rate, are in a form of peaks (\rightarrow cyclic voltammetry, \rightarrow current-voltage curve). Some systems, called “superconductors” exhibit $R = 0$ but, so far, they are practically applicable only at temperatures below 100 K. Ohm's law can be extended to \rightarrow alternating current circuits (where U and I are periodic functions of time), then “ R ” in Ohm's law is called \rightarrow impedance, and a symbol Z is usually used then to denote that it is a complex quantity (\rightarrow impedance spectroscopy).

PK

Oil-water interface — Interface formed between a water-immiscible liquid (oil) and water. In electrochemistry, when \rightarrow electrolytes are dissolved in both phases, it is also often called the \rightarrow interface between two immiscible electrolyte solutions (ITIES).

TO

Oilbag \rightarrow Acheson® graphite

Onsager, Lars



(Nov. 27, 1903, Christiana, now Oslo, Norway – Oct. 5, 1976, Coral Gables, FL, USA) Norwegian-born American physical chemist, studied at the Norwegian Institute of Technology, with \rightarrow Debye in Zürich, went to Yale in 1928, studied and taught there from 1934

until 1972, became a naturalized US citizen in 1945, received the Nobel Prize in Chemistry in 1968 for the discovery of the reciprocity relations as foundations of thermodynamics of irreversible processes. See also → *Debye–Hückel–Onsager theory*, → *Onsager equation*, → *Onsager reciprocal relations*.

Refs.: [i] Magnusson M (ed) (1990) *Chambers biographical dictionary*. W&R Chambers, Edinburgh; [ii] Crystal D (ed) (1998) *The Cambridge biographical encyclopedia*. Cambridge University Press, Cambridge

RH

Onsager equation — (a) → *Debye–Hückel–Onsager equation*, see also → *Debye–Hückel–Onsager theory*.

Ref.: [i] Bockris JO'M, Reddy AKN (2006) *Modern electrochemistry*. Springer, New York

RH

Onsager equation — (b) The Onsager equation is an extension of the → *Debye–Clausius–Mosotti equation*, and it relates the → *dielectric constant* ϵ_r with the → *dipole moment* $\bar{\mu}$:

$$\frac{4\pi N}{3} \frac{\bar{\mu}^2}{3kT} = \frac{(\epsilon_r - n_\infty^2)(2\epsilon_r + n_\infty^2)}{\epsilon_r(n_\infty^2 + 2)^2} [i].$$

(N is the number of molecules per unit volume, k is the → *Boltzmann constant*, T is the absolute temperature, and n_∞ is diffraction index extrapolated to long wavelengths.) For most of the polar molecules the Onsager equation is superior to the Debye–Clausius–Mosotti equation; however, for a number of strongly associating solvents, e.g., water, liquid HF, etc., more elaborate formulas have to be used.

Refs.: [i] Onsager L (1936) *J Am Chem Soc* 58:1486; [ii] Kortüm G (1962) *Lehrbuch der Elektrochemie*. Verlag Chemie, Weinheim, pp 121–129

FS

Onsager reciprocal relations — For coupled fluxes J_i and J_j :

$$J_i = L_{ii}X_i + L_{ij}X_j \quad (1)$$

$$J_j = L_{ji}X_i + L_{jj}X_j \quad (2)$$

where L_{ii} , L_{ij} , L_{ji} , and L_{jj} are the transport coefficients and X_i and X_j are the driving forces. Onsager postulated the following relationship: $L_{ij} = L_{ji}$ proving that these coefficients are invariably symmetrical [i–iii]. This principle is known as Onsager reciprocal (reciprocity or symmetry) relations. For the fluxes of diffusional → *mass transport* (J_1) and → *charge transport* (J_2) it can be written:

$$J_1 = L_{11}X_1 + L_{12}X_2 \quad (3)$$

$$J_2 = L_{21}X_1 + L_{22}X_2 \quad (4)$$

where X_1 is the gradient of the → *chemical potential* and X_2 the gradient of the electric → *potential*. It follows that

$L_{12} = L_{21}$. For the combination of → *diffusion* and electrical conduction (→ *conductance*) of electrolytes

$$J_i = - L_{ii}(\text{grad } \mu_i + z_i F \text{grad } \varphi) \quad (5)$$

where μ_i is the chemical potential, φ is the → *inner electric potential*, z_i is the → *charge number of ions*, and F is the → *Faraday constant*.

Equation (5) can be written in a shortened form and for all ions present in the solution since only the combination of μ_i and φ , i.e., the → *electrochemical potential* ($\bar{\mu}_i$) is uniquely defined in these systems:

$$J_i = - \sum_{k=1}^n L_{ik} \text{grad } \bar{\mu}_k \quad (6)$$

In dilute electrolytes $L_{ik} = 0$ ($i \neq k$) because the interactions between ions becomes practically zero. Then,

$$L_{ii} = \frac{u_i c_i}{|z_i| F} \quad (7)$$

where u_i is the → *mobility*, c_i is the concentration of i^{th} ions. Based on Eqs. (5) and (7) the relationship between the mobility and diffusion coefficients (→ *Nernst–Einstein equation*), as well as the → *diffusion potential* can also be obtained.

Refs.: [i] Onsager L (1931) *Phys Rev* 37:405, 38:2265; [ii] Onsager L (1968) *The motion of ions*, Nobel Lecture; [iii] Guggenheim EA (1993) *Thermodynamics*. Elsevier, Amsterdam, p 362

GI

Open circuit potential (OCP) → *potential*, subentry → *open circuit potential (OCP)*

Operational amplifier — An electronic device (available in numerous different forms, built with discrete components, in thick film or thin film technology, but mostly as an integrated solid state circuit IC). It is an amplifier with ideally infinite input → *impedance*, zero output impedance, response behavior independent of the rate of change of the input signal (amplification constant from DC to high frequency AC). It is schematically plotted as a triangle:

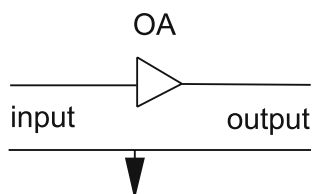

Operational amplifier — Figure

This device used as plotted would be useless, because even a small input voltage would result in an output voltage approaching the supply voltage operating the O.A. Thus various types of feedback circuitry are employed resulting in voltage followers (impedance converters), current followers, integrators.

Refs.: [i] Barna A, Porat DI (1989) *Operational amplifiers*. Wiley, New York; [ii] Bard AJ, Faulkner LR (2001) *Electrochemical methods*, 2nd edn. Wiley, New York, p 632; [iii] Horowitz P, Hill W (1989) *The art of electronics*. Chap. 4, Cambridge University Press, Cambridge; [iv] Clayton GB, Newby BWG (1992) *Operational amplifiers*. Butterworth-Heinemann, Oxford; [v] Clayton G, Winder S (2003) *Operational amplifiers*. Newness, Oxford; [vi] Huijsing JH (2001) *Operational amplifiers: theory and design*. Kluwer, Boston

RH

Optical beam deflection → *probe beam deflection*

Optical cell → *grazing angle optical cell*, → *long path length optical cell*

Optically transparent electrode — (OTE), the electrode that is transparent to UV-visible light. Such an electrode is very useful to couple electrochemical and spectroscopic characterization of systems (→ *spectroelectrochemistry*). Usually the electrodes feature thin films of metals (Au, Pt) or semiconductors (In₂O₃, SnO₂) deposited on transparent substrate (glass, quartz, plastic). Alternatively, they are in a form of fine wire mesh minigrids. OTE are usually used to obtain dependencies of spectra (or absorbance at given wavelengths) on applied potentials. When the → *diffusion layer* is limited to a thin layer (i.e., by placing another, properly spaced, transparent substrate parallel to the OTE), bulk electrolysis can be completed in a few seconds and, for → *reversible* or → *quasireversible* systems, equilibrium is reached for the whole solution with the electrode potential. Such OTEs are called optically transparent thin-layer electrodes or OTTLE's.

Historically, OTEs were used to investigate complex redox reactions including mediated reactions of enzymes (→ *mediators*). Recently OTEs have been extensively applied to study spectroelectrochemical properties of thin films of electrochromic materials (→ *electrochromic devices*, → *electrochromism*), and various chromic deposits including bioelectrochemical materials (e.g. → *enzymes*) or network films of gold → *nanoparticles*. They are often used in → *photoelectrochemistry* as electrode materials.

See also the fluorine-doped tin oxide electrode (→ *FTO*).

Refs.: [i] Bard AJ, Faulkner LR (2001) *Electrochemical methods*, 2nd edn. Wiley, New York; [ii] Kissinger PT, Heineman WR (eds) (1996) *Laboratory techniques in electroanalytical chemistry*, 2nd edn. Marcel Dekker, New York

PK

Optical spectroscopy → *Spectroscopy* performed in the visible region of the electromagnetic spectrum generally between 300 and 1000 nm.

RH

Order of reaction, *n* (SI unit: 1) — If the macroscopic (observed, empirical, or phenomenological) → *reaction rate*, *v*, for any reaction can be expressed by an empirical differential rate equation, which contains a factor of the form $k[A]^\alpha[B]^\beta \dots$ (expressing in full the dependence of the rate of reaction on the concentrations [A], [B] ...), where α and β are constant exponents (independent of concentration and time) and *k* is the rate constant (rate coefficient) independent of [A] and [B] etc., then the reaction is said to be of order α with respect to A, of order β with respect to B, etc., and of (total or overall) order $n = \alpha + \beta + \dots$. The exponents α , β , etc. can be positive or negative integral or rational nonintegral numbers. They are the reaction orders with respect to A, B, etc., and are sometimes called partial orders of reaction. Orders of reaction deduced from the dependence of initial rates of reaction on concentration are called 'orders of reaction with respect to concentration'; orders of reaction deduced from the dependence of the rate of reaction on time of reaction are called 'orders of reaction with respect to time'.

The concept of order of reaction is also applicable to chemical processes occurring in systems for which concentration changes (and hence the rate of reaction) are not themselves measurable, provided it is possible to measure a chemical flux. For example, if there is a dynamic equilibrium described by the equation

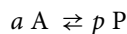

and if a chemical flux of A, φ_{-A} , is experimentally found (e.g., by analysis of the NMR line shape) to be related to concentrations by the equation

$$\varphi_{-A}/a = k[A]^\alpha[L]^\lambda$$

then the corresponding reaction is of order α with respect to A, etc., and of total (or overall) order $n (= \alpha + \lambda + \dots)$. The proportionality factor, *k*, is called the (*n*-th order) → *rate constant*. Rate constants referring to (or believed to refer to) elementary reactions are called rate

constants or, more appropriately, ‘microscopic’ (hypothetical, mechanistic) rate constants. The (overall) order of a reaction cannot be deduced from measurements of a ‘rate of appearance’ or ‘rate of disappearance’ at a single value of the concentration of a species whose concentration is constant (or effectively constant) during the course of the reaction. If the overall rate of reaction is, for example, given by

$$v = k[A]^\alpha[B]^\beta$$

but [B] is constant, then the order of the reaction (with respect to time), as observed from the concentration change of A with time, will be α , and the rate of disappearance of A can be expressed in the form

$$v_A = k_{\text{obs}}[A]^\alpha$$

The proportionality factor, k_{obs} deduced from such an experiment, is called the “observed rate constant” and is related to the $(\alpha + \beta)$ th order rate constant, k , by the equation

$$k_{\text{obs}} = k[B]^\beta.$$

For the common case when $\alpha = 1$, k_{obs} is often referred to as a pseudofirst-order rate constant (k_ψ).

For a simple (elementary) reaction, a partial order of reaction is the same as the \rightarrow *stoichiometric number* of the reactant concerned and must, therefore, be a positive integer (see \rightarrow *reaction rate*). The overall order is then the same as the molecularity. For stepwise reactions there is no general connection between stoichiometric numbers and partial orders. Such reactions may have more complex rate laws, so that an apparent order of reaction may vary with the concentrations of the chemical species involved and with the progress of the reaction: in such cases it is not useful to use the orders of reaction terms, although apparent orders of reaction may be deducible from initial rates. In a stepwise reaction, orders of reaction may in principle always be assigned to the elementary steps.

Ref.: [i] Muller P (1994) *Pure Appl Chem* 66:1077

WK

Organic compounds, electrochemistry of

Anodic processes involving reactions of mercury ions with organic compounds \rightarrow Oxidation of mercury electrodes increases with increasingly positive potentials. Resulting mercury (I) or (II) ions can react with organic compounds (X) or their anions (X^-) present in the solution following the sequence:

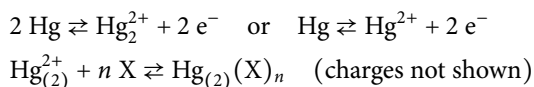

Compound X or anion X^- can either act as a complexing agent or form slightly soluble salts with mercury. If X is a complexing agent, like the anion of EDTA, the \rightarrow *limiting current* in \rightarrow *DC polarography* of the resulting anodic wave is a linear function of concentration and is limited by \rightarrow *diffusion*.

For anions of organic compounds, like thiols (i), derivatives of urea and thiourea (ii) such as barbituric and thiobarbituric acids and their derivatives, as well as for some heterocyclic compounds, the reaction product $\text{Hg}_2(X)_n$ is slightly soluble. In such cases the anodic wave is a linear function of concentration only until a concentration is reached, when the surface is covered by $\text{Hg}_2(X)_n$. With a further increase in concentration the limiting current of the anodic wave becomes independent of concentration of X. Such limiting current is controlled by adsorption and is a linear function of the height of the mercury column (h). From the concentration at which the electrode surface is covered by $\text{Hg}_2(X)_n$ it is possible to calculate the surface area covered by the species $\text{Hg}_2(X)_n$.

For some compounds, after this concentration is reached, an increase of another anodic wave is observed at more positive potentials. The height of this more positive wave increases with increasing concentration of the organic compound and for some compounds this wave too reaches a limiting value. The more positive wave can result from desorption of the $\text{Hg}_2(X)_n$ or is due to a formation of another, slightly soluble compound with mercury. This compound can differ from $\text{Hg}_2(X)_n$ either by the oxidation state or mercury or the number of ligands n . Finally, the structure of the adsorbed layer at these more positive potentials can be different from that formed at more negative potentials. The difference can be due either to a different orientation of the adsorbed organic compound in the layer or in the number of layers in the adsorbate.

Refs.: [i] Březina M, Zuman P (1956) *Polarography in medicine, biochemistry and pharmacy*. Interscience, New York; [ii] Zuman P (1955) *Collect Czech Chem Commun* 20:649, 1020; Koryta J, Zuman P (1953) *Collect Czech Chem Commun* 18:197; Zuman P, Koryta J, Kalvoda R (1953) *Collect Czech Chem Commun* 18:350; Manoušek O, Zuman P (1955) *Collect Czech Chem Commun* 20:1340; Fedoroňko M, Manoušek O, Zuman P (1956) *Collect Czech Chem Commun* 21:672; [iii] Heyrovský J, Kuta J (1966) *Principles of polarography*. Academic Press, New York, pp 171–179

PZ

Electrooxidations of organic compounds — Examples of easily oxidized groupings that can be studied using the \rightarrow *dropping mercury electrode* or other types of mercury electrodes are hydroquinones (both para- and ortho-), hydroquinone-like heterocyclic compounds, *o*- and *p*-phenylenediamines, enediol compounds, like ascorbic acid, with grouping HO-CH=CH-OH, geminal diol anions [$>C(OH)O^-$] formed by addition of OH^- ions to formyl groups in aldehydes, some heterocyclic compounds, and derivatives of hydrazine and hydroxylamine. To follow oxidations of less easily oxidized organic compounds, like phenols, anilines, amines, and thiols, and some heterocycles, which takes place at more positive potentials, it is necessary to use solid \rightarrow *working electrodes*, such as carbon, gold, silver, or platinum.

Refs.: [i] Bard AJ, Lund H (eds) (1978–1984) *Encyclopedia of electrochemistry of elements*, vols. XI–XV. Marcel Dekker, New York; [ii] Lund H, Hammerich O (eds) (2001) *Organic electrochemistry*, 4th edn. Marcel Dekker, New York; [iii] Meites L, Zuman P (1976–1983) *Handbook series in organic electrochemistry*, vols. I–VI. CRC Press, Boca Raton; [iv] Adams RN (1969) *Electrochemistry at solid electrodes*. Marcel Dekker, New York; [v] Torii S (1985) *Electroorganic synthesis. Part 5. Oxidation methods and applications*. Kodansha and VCH, Tokyo; [vi] Shono T (1984) *Electroorganic chemistry as a new tool in organic synthesis*. Springer, Berlin

Electroreductions of organic compounds \rightarrow *reductions* of organic compounds on cathodes belong to three main categories: (1) hydrogenation of multiple bonds; (2) reductive cleavage of single bonds; and (3) generation of radicals or radical anions, which can undergo further chemical or electrochemical reactions.

(1) Hydrogenation of multiple bonds, like C=C, C=O, C=N, C=S, N=N, C \equiv C, N \equiv N, and bonds in NO and NO₂, bonds in quinones and quinone-like structures and in aromatic rings are often followed in protic media. Under such conditions such reductions often involve a proton transfer, either preceding or following the electron transfer.

(2) Cleavage of single bonds, such as C–Cl, C–Br, C–I, O–O, or S–S is often sufficiently facile that it can occur in molecules containing only such bonds and no activating groupings. On the other hand, reductive splitting of bonds like C–F, C–O, C–N, and C–S, as well as N–O and N–N, can usually occur only in the presence of an adjacent activating group. For example, the C–N bond in amines is usually difficult to cleave reductively, but in α -aminoketones the C–N bond can be reductively split, even before the carbonyl group is reduced.

(3) Radicals and radical anions can undergo dimerization, can form intramolecular bonds, can react with

another group in the parent molecule, with ions of the supporting electrolyte, or react with solvent used.

Refs.: [i] Bard AJ, Lund H (eds) (1978–1984) *Encyclopedia of electrochemistry of elements*, vols. XI–XV. Marcel Dekker, New York; [ii] Lund H, Hammerich O (eds) (2001) *Organic electrochemistry*, 4th edn. Marcel Dekker, New York; [iii] Meites L, Zuman P (1976–1983) *Handbook series in organic electrochemistry*, vols. I–VI. CRC Press, Boca Raton; [iv] Zuman P (1971) *Substituents effects in organic polarography*. Plenum Press, New York

PZ

Reduction of organic compounds with two electroactive centers on an aromatic ring — Frequently, the \rightarrow *reductions* of organic compounds bearing two electroactive centers on one aromatic ring follow reductions of individual groups in the same sequence in which they would be reduced, where each of them would be reduced if present separately on the same aromatic ring. For example, nitrobenzenes are reduced at much more positive potentials than benzaldehydes or acetophenones. Hence in the reduction of nitrobenzaldehydes or nitroacetophenones, the nitro group is reduced first, followed by a reduction of the carbonyl group at more negative potentials. This applies to all reported reductions of aromatic compounds, where the two reducible groups are in *meta*-position.

If the two reducible groups are in an 1,2- or 1,4-position, the strong interaction between the two groups can result in a change in mechanism which results in a reversal of the sequence of the reductions, that would be expected based on the behavior of compounds bearing a single electroactive group.

Perhaps the most striking example of such behavior is the reduction of halonitrobenzenes and halobenzonitriles [i]. Even when the reduction of halobenzenes occurs at more negative potentials than that of nitrobenzenes or benzonitriles, in halonitrobenzenes and halobenzonitriles the acceptance of the first electron yields a radical anion, sufficiently stable to eliminate the halide ion. The resulting radical of nitrobenzene or benzonitrile accepts the second electron and a proton. This is followed by the usual reduction of the NO₂ or CN group. Thus formally, the C–X bond is reduced before the NO₂ or CN group.

Protonation in the vicinity of the electrode can also play a role in the reversal of sequence and change in mechanism. Thus in *p*-cyanoacetophenone the cyano group is protonated in acidic media and is first reduced. The *p*-acetyl group, which here acts as a strong electron-withdrawing substituent, is then reduced at more negative potential. Such reversal of the sequence does not occur at higher pH-values, where the rate of

protonation of the CN group is not sufficiently fast. Under such conditions the reduction follows the expected sequence and the carbonyl group is reduced first [ii]. Another example of a strong interaction between two electroactive groups in *para*-position are reductions of *p*-diacetylbenzene [iii] and terephthalaldehyde [iv], where diprotonated forms undergo in acidic media a two-electron reversible reduction yielding a di-radical quinonemethide. In monoprotinated forms sequential reductions of the two carbonyl groups occurs.

The hydration can also affect differently compounds with two reducible formyl groups. In isophthalaldehyde the interaction between two CHO groups in *meta*-position is relatively weak and does not affect the degree of the hydration of the first CHO group reduced. The hydration of the first group is below 5% as with other substituted benzaldehydes [v]. The total limiting current thus corresponds to a diffusion controlled four-electron process [iv]. In terephthalaldehyde, on the other hand the two CHO groups in *para*-position show a strong resonance interaction. The hydration of one CHO group reaches 25% and the reduction current of the first reduced CHO group is significantly lower than would correspond to a two-electron diffusion controlled process.

Refs.: [i] Bard AJ, Lund H (eds) (1980) *Encyclopedia of electrochemistry of elements*, vol. XIV. Marcel Dekker, New York, pp 1–308; [ii] Manoušek O, Zuman P, Exner O (1968) *Collect Czech Chem Commun* 33:3979; [iii] Kargin J, Manoušek O, Zuman P (1966) *J Electroanal Chem* 12:443; [iv] Zuman P, Manoušek O, Vig SK (1968) *J Electroanal Chem* 19:147; Baymak MS, Bover WJ, Celik H, Zuman P (2005) *Electrochim Acta* 50:1347; [v] Zuman P (2002) *Arxivoc* 1:540

PZ

Reversibility of organic oxidation–reduction electrode processes — When the \rightarrow electron transfer is not accompanied by chemical reactions of the oxidized or of the reduced form or when such reactions involve very rapidly established equilibria, the oxidation–reduction process is described as electrochemically reversible, if the equilibrium $\text{Ox} + n e^- \rightleftharpoons \text{Red}$ is rapidly established [i, ii]. Attribution of \rightarrow reversibility depends on the technique used, actually on the \rightarrow time scale of the experiment. In \rightarrow potentiometry a system is described as reversible when the above equilibrium is established within minutes. In \rightarrow polarography using \rightarrow dropping mercury electrodes with drop-times of the order of seconds, such equilibrium must be established within fractions of a second. In \rightarrow cyclic voltammetry generally the establishment of the \rightarrow redox equilibrium must be achieved during a much shorter period of time. The actual limit depends on the rate of voltage scanning. Experimental evidence of the rapidly established redox

equilibrium is the practical identity (within less than 0.06 V) of the potentials of the reduction of the oxidized form with the potential of the oxidation of the reduced form. To test for reversibility under conditions of cyclic voltammetry solution of only one – oxidized or reduced-form is needed. In polarography, to obtain the curves of both reduction and those of oxidation, both oxidized and reduced forms must be available. If one of these forms is not stable or available, the information under conditions of polarography, can be obtained by using rectangular voltage polarization, obtained by \rightarrow Kalousek commutator method [iii]. In this technique the current of the electrolysis product is measured and the *I*–*E* curve of the product is recorded. Such curves can be compared with those of the starting material. Typical examples of reversible systems, when a dropping mercury electrode is used in protic media, are systems like *p*- or *o*-quinone – corresponding hydroquinones, those of quinone-like heterocyclic compounds particularly those with 1,4 or 1,2-nitrogen atoms and aryl nitroso compounds – corresponding arylhydroxylamines. In aprotic media the transfer of the first electron to numerous systems is often reversible.

Refs.: [i] Heyrovský J, Kuta J (1965) *Principles of polarography*. Academic Press, New York, pp 161–165; [ii] Bond AM (2005) *Modern polarographic methods in analytical chemistry*, 2nd edn. Marcel Dekker, New York, pp 14–23; [iii] Heyrovský J, Kuta J (1965) *Principles of polarography*. Academic Press, New York, pp 477–495

PZ

Ring size effects on reduction of organic compounds — For aromatic compounds, bearing an irreversibly reducible group in the side chain (such as a nitro or a formyl group) the \rightarrow reduction is shifted to more positive potentials in the sequence: benzene < naphthalene < anthracene. This is due to an increase in conjugation. For alicyclic compounds the reduction can occur: (a) in the side-chain; (b) as a reductive substitution of a group, attached to the ring; (c) it can be due to a hydrogenation of a double bond involving an exocyclic atom linked to an atom which is a part of the ring; (d) hydrogenation of a bond that is a part of the ring.

(a) Too limited information is available for reductions of groups like nitro, acetyl, or formyl attached to alicyclic rings of various sizes. (b) The potentials of reductions of cycloalkylbromides correlate well with logarithms of rate constants of corresponding S_N2 reactions, such as substitution by iodides. No correlation with rates following S_N1 mechanisms was observed [i]. (c) Reduction potentials of cyclanones and their derivatives show good correlations with half-wave potentials of cycloalkylbromides [i]. The reduction of the un-

protonated forms of benzocyclenones occurs at most positive potential for the tetralone with six-membered ring, followed by the indanone with five-membered ring, and by benzosuberone with a seven-membered ring [ii]. (d) Hydrogenation of the ethylenic bond in α,β -unsaturated ketones occurs at only slightly more positive potentials in six-membered ring, than in five-membered ones. For 1,2-dibromoderivatives, when reduction results in elimination yielding an ethylenic bond the reduction occurs at most positive potentials for 1,2-dibromocyclopentanone, followed by the cycloheptane and cyclohexane derivatives [i].

Refs.: [i] Zuman P (1965) *Talanta* 12:1337; [ii] Toure V, Levy M, Zuman P (1974) *J Electroanal Chem* 56:285

Role of conjugation in the reduction of organic compounds — Extension of conjugation in organic molecules, where the electroactive group is adjacent to an ethylenic, acetylenic, azomethine, or thioketone bond or to an aromatic – benzenoid or heterocyclic – ring results in a shift of the reduction potential of irreversible reductions towards more positive potentials. Thus, for example, benzaldehydes are reduced at more positive potentials than acetaldehyde or a nitropyridine than nitrocyclohexane, etc. [i, ii, iii]. Not all systems containing adjacent double bonds are conjugated. Whereas in systems like $C=C-C=C$, $C=C-C=O$, $C=C-C=N$, $N=C-C=N$ conjugation plays a role, in systems containing $C=N-N=C$ it does not (iv). In α,β -unsaturated ketones the ethylenic bond is hydrogenated prior to the reduction of the carbonyl group (v). In the reversible systems of quinone–hydroquinone the dianion of the hydroquinone is more strongly conjugated than the quinone. Hence in the sequence: 1,4-benzoquinone < 1,4-naphthoquinone < 9,10-anthraquinone the redox potential is shifted to more negative values.

Refs.: [i] Bard AJ, Lund H (eds) (1978–1984) *Encyclopedia of electrochemistry of elements*, vols. XI–XV. Marcel Dekker, New York; [ii] Meites L, Zuman P (1976–1983) *Handbook series of organic chemistry*, vols. I–VI. CRC Press, Boca Raton; [iii] Zuman P, Perrin CL (1984) *Organic polarography*. Wiley, New York; [iv] Zuman P, Ludvík J (2000) *Tetrahedron Lett* 41:7851; [v] Zuman P, Spritzer L (1976) *J Electroanal Chem* 69:433

PZ

action $>C=O + H_2O = >C(OH)_2$ only the free carbonyl group with $>C=O$ grouping is reducible. The limiting current depends on the value of the equilibrium constant $K_\alpha = [>C=O]/[>C(OH)_2]$ and on the rate by which the form with group $>C(OH)_2$ is converted into one with $>C=O$ (usually a \rightarrow kinetic current). Limiting currents in such situations are often much smaller than the corresponding diffusion current, but increase with increasing acidity and with increasing pH. This is due to the acid- and base-catalyzed rate of dehydration. Currents affected by hydration are often observed for aliphatic aldehydes [i], aldehydes bearing a halogen in α -ketoaldehydes, few substituted benzaldehydes (nitrobenzaldehydes) [iv], tere- and orthophthalaldehydes [v], pyridine-carboxaldehydes [vi], ketones bearing halides in α -position [ii], 1,2-diketones [vii], and α -ketoacids [viii]. Hydration of the azomethine bond was observed for some heterocycles, like some pyrimidines, 1,2,4- and 1,3,5-triazines [iii] and pteridines [xi].

Addition of hydroxide ions results in formation of a geminal diol anion: $-CH=O + OH^- = CH(OH)O^-$ (ix). As shown for substituted benzaldehydes, resulting anion undergoes in alkaline media electrooxidation to a carboxylate anion. The height of the anodic wave of this process is controlled by the rate of addition of the OH^- ions. The limiting current increases with increasing activity of OH^- ions until it reaches a diffusion-controlled value, corresponding to a two-electron process.

Refs.: [i] Zuman P (1977) *J Electroanal Chem* 75:523; [ii] Scott WJ, Zuman P (1976) *J Chem Soc Faraday Trans I* 72:1192; (1981) *Anal Chim Acta* 126:71; Romer MM, Zuman P (1975) *J Electroanal Chem* 64:258; [iii] Privman M, Zuman P (1998) *J Electroanal Chem* 455:235; Ludvík J, Riedel F, Liška F, Zuman P (1998) *J Electroanal Chem* 457:177; *Electroanalysis* 10:869; Zuman P (2002) *Arhivov* 1:540; [iv] Person M, Meunier JM, Beau D (1972) *CR Acad Sci Paris* 275:527; [v] Bover WJ, Baymak MS, Camaione L, Zuman P (2003) *Electrochem Commun* 5:334; Baymak MS, Bover WJ, Celik H, Zuman P (2005) *Electrochim Acta* 50:1347; [vi] Rusling JF, Segretario JP, Zuman P (1983) *J Electroanal Chem* 143:291; Rusling JF, Zuman P (1986) *J Electroanal Chem* 213:245, 255, 277; [vii] Segretario JP, Sleszynski N, Partch RE, Zuman P, Horak V (1986) *J Org Chem* 51:5393; [viii] Kozłowski J, Zuman P (1992) *J Electroanal Chem* 343:43; [ix] Bover WJ, Zuman P (1975) *J Electrochem Soc* 122:368

PZ

Role of covalent hydration and addition of OH^- ions — In aqueous solutions the reductions of some carbonyl compounds, for example of numerous aldehydes [i], and some ketones [ii] as well as of some compounds with azomethine ($C=N$) bonds [iii] are complicated by hydration–dehydration equilibria. In a re-

PZ

Role of keto-enol equilibria in electroreduction — Contrary to earlier interpretations of reduction of numerous carbonyl compounds, the role of keto-enol equilibria in electroreductions of carbonyl compounds is rather limited. This is caused by a rapid – acid- or base-catalyzed – conversion of any enol present in the solution or formed in the course of electrolysis into the more

easily reducible keto form in the vicinity of the electrode. Even when carbanion-enolates are formed during the reduction of 1,3-diketones, it is the keto form which is reduced [i]. A rare example of confirmed reduction of the enol form involves that of oxalacetic acid [ii].

Refs.: [i] Nisli G, Barnes D, Zuman P (1970) *J Chem Soc B, Phys Org Chem* 764:771, 778; [ii] Kozłowski J, Zuman P (1992) *J Electroanal Chem* 28:43

PZ

Substituent effects in organic polarography —

Changes in reduction or oxidation potentials, due to an introduction of a group into the molecule, which is itself not electroactive in the given potential range, but causes changes in the studied redox potential, are called substituent effects. Evaluation of substituent effects is carried out in a group of compounds bearing the same electroactive group, called “reaction series.” To evaluate quantitatively the effects of substituents on the redox potentials, all compounds in the reaction series must be reduced or oxidized following the same mechanism. An introduction of a substituent in the vicinity of the electroactive group, can – due to steric and direct field effects – affect not only potentials, but also the mechanism of the electrode process. Therefore, the comparison of substituent effects is first restricted to those compounds where substituents are located at some distance, i.e., several atoms away from the electroactive center. The most frequently encountered example of such substituent effects are reductions or oxidations of aromatic compounds, in which the substituents are located in position 4- or 3- relative to the electroactive group in position 1-. In such reaction series the shift of the redox potential at a compound bearing a *p*- or *m*-substituent X on the benzene ring (E_X^R) relative to the redox potential of the unsubstituted parent compound (E_H^R) with the electroactive grouping R is given by equation: $E_X^R - E_H^R = \rho_\pi^R \sigma_X$, where σ_X is a tabulated Hammett substituent constant and ρ_π^R is a proportionality constant (in volts) called reaction constant. The value of ρ_π^R depends on the nature of the electroactive group. Its value expresses the susceptibility of the reduction or oxidation potential of group R to the effects of substituents. It has been observed empirically that the more positive is the potential of the unsubstituted molecule (E_H^R) the smaller the value of ρ_π^R . This means that compounds which are less easily reduced (at less positive potentials) show smaller effects of substituent X on potential E_X . – When the values of E_H^R and ρ_π^R are known for a given electroactive group R, it is possible to predict the value of E_X^R for a substituent X that has not been yet studied, if the value σ_X is known. Perhaps more importantly, deviations from a linear plot

of $E_X^R = f(\sigma_X)$ may indicate a change in mechanism for the deviating compound. Similar approaches to substituent effects in heterocyclic aromatic and in aliphatic compounds have more restricted applications.

See also → *linear free energy relationship*.

Ref.: [i] Zuman P (1967) *Substituent effects in organic polarography*. Plenum Press, New York

PZ

Organic radical battery — Group of rechargeable → *batteries* based on a redox couple with one organic radical, e.g., the poly(2,2,6,6-tetramethylpiperidinyloxy methacrylate) radical.

Refs.: [i] Nakahara K, Iwasa S, Satoh M, Morioka Y, Iriyama J, Suguro M, Hasegawa E (2002) *Chem Phys Lett* 359:351; [ii] Satoh M (2005) *NEC J Adv Technol* 2:262

FS

Ørsted, Hans Christian



(Aug. 14, 1777, Rudkøbing, Denmark – Mar. 9, 1851, Copenhagen, Denmark) From 1806 Ørsted was Professor in Copenhagen. He worked both as a chemist and as a physicist. In 1820 he discovered during a lecture the effect of an electric current flowing through a metal wire on a nearby magnetic needle, and thus initiated the study of electromagnetism. Soon afterwards → *Ampère* heard about this finding and immediately began research on electromagnetism, as did → *Faraday* in England, → *Schweigger* in Germany, and *Nobili* in Italy. The observation of Ørsted prompted → *Poggendorff* to invent the first electromagnetic measuring instrument, the so-called multiplier (see also → *Schweigger* who independently developed a multiplier). In 1823, Ørsted and J.-B.J. de Fourier constructed the first thermopile. In honor of this Danish scientist the non-SI unit of magnetic field strength is called the ørsted.

Refs.: [i] Ostwald W (1896) *Elektrochemie. Ihre Geschichte und Lehre*. Veit Comp, Leipzig; (Engl transl: Ostwald W (1980) *Electrochemistry. History and theory*, 2 vols. Amerind Publ, New Delhi)

FS

ORTA → *electrode materials*

Oscillation of electrochemical systems → *electrochemical oscillations*

Oscillometry — Also called high frequency conductometry or high frequency titration. A variant of → *conductometry*, but working with frequencies of the order of 10^6 to 10^7 Hz compared with 10^3 Hz for classical → *conductance* measurements. High working frequency allows applying electrodes outside the solution separated from it by glass walls. Electrodes can be coupled inductively or capacitively. The oscillometric response is composed of resistive as well as capacitive contributions of the solution and the cell itself. With solutions of high → *dielectric constant*, but low conductivity, the response is primarily capacitive. In → *titrations*, the curve shape generally is nonlinear, often v-shaped or inverted v-shaped. Applications: determination of weak acids in lubricants; analysis of binary mixtures where dielectric constants of the constituents differ (e.g., acetone/water; hexane/benzene), and any cases where the solutions could corrode the electrodes or spoil their response. An actual medical application is noninvasive, fast blood pressure measurement.

Refs.: [i] Pungor E (1965) *Oscillometry and conductometry*. Pergamon Press, New York; [ii] Sugimachi M, Okamoto H, Hoka S, Sunagawa K (2004) *Blood Press Monit* 9:135

Oscillopolarography — Obsolete variants of → *polarography*, in which the → *dropping mercury electrode* was polarized by an alternating potential or alternating current, or by potential or current pulses. The recorded polarization curves were potential–time curves ($E-t$ curves), (dE/dt) versus time curves, or (dE/dt) versus potential curves. Therefore, the technique is akin to → *chronopotentiometry*. The name of the techniques refers to the use of oscillographs for recording. At the time of its development the technique was important because faster electrode processes could be studied than in the classic DC polarography. The term oscillopolarography has also been used when current versus potential (time) curves were recorded with an oscillograph for linear potential scans performed within the lifetime of the mercury droplets.

Refs.: [i] Heyrovský J, Kůta J (1965) *Grundlagen der Polarographie*. Akademie-Verlag, Berlin, (English translation: Heyrovský J, Kůta J (1965) *Principles of polarography*. Academic Press, New York); [ii] Kalvoda R (1965) *Techniques of oscillographic polarography*. Elsevier, Amsterdam; [iii] Heyrovský J, Kalvoda R (1960) *Oscillographische Polarographie*

mit Wechselstrom. Akademie-Verlag, Berlin; [iv] Heyrovský M, Míčka K (1967) *Oscillographic polarography at controlled alternating current*. In: Bard AJ (ed) *Electroanalytical chemistry*, vol. 2. Marcel Dekker, New York, p 193

FS

Osmosis — refers to the flow of a → *solvent* in a system, in which two solutions of different concentration are separated by a semipermeable → *membrane* or → *diaphragm*. It was first described in 1748 by → *Nollet* and in 1877 experimentally quantified by the German botanist Wilhelm Friedrich Philipp Pfeffer (1845–1920) using what is now called Pfeffer cell (see → *osmotic pressure*). Contrary to the case of a fully permeable membrane (transfer of solute; see: → *electrodialysis*), solvent molecules are transferred from the lower concentrated (or ‘hypotonic’) to the higher concentrated (or ‘hypertonic’) solution. If no osmosis occurs, the two solutions are called ‘isotonic’. When a solute is dissolved in a solvent, the random mixing of the two species results in an increase of the system’s → *entropy*, which corresponds to a lowering of the → *chemical potential* of the solvent, which is the driving force for the → *diffusion* of solvent through the semipermeable membrane. Assuming an ideal solution behavior that most real solutions approximate for low solute concentrations, this reduction in chemical potential corresponds to: $RT \ln(1 - X)$, where X is the relative solute concentration in terms of mole fraction. If the higher concentrated solution is in a self-contained volume, then the inflowing solvent generates a hydrostatic pressure, which counteracts the dilution affinity, and the net flow will slow down. The hydrostatic pressure equals the so-called → *osmotic pressure* in size, but is opposite in sign. The osmotic flow will stop when both, the forth and back fluxes through the membrane, are equal and the chemical potential is equal on both sides. If further external pressure is exerted against the net solvent flux, the transfer of solvent can be even reversed (‘reverse osmosis’). → *Electroosmosis* refers to the process in which water is transported across an anion or cation exchange membrane under an applied electric field. The case of two different solvents on both sides of the semipermeable membrane is called diosmosis; the transfer rate of the solvents through the membrane in this case may be different. Since biological cell membranes possess semipermeability, osmosis plays a crucial role in living matter: Exemplarily, distribution of nutrients, transport and regulation of water, and the intrinsic pressure called ‘turgor’ in plant cells are all connected to osmotic and reverse-osmotic phenomena. The maintenance of a constant osmotic pressure within the hu-

PG

man blood and tissue fluid is called 'osmoregulation' and is employed via uptake or delivery of water, minerals, and especially the release of osmotically active metabolites (urea). 'Osmoreceptors', hormonal balancing systems and organs with resorptive and excretory function as kidney, mucous membranes, and skin, serve for that purpose. Many aquatic organisms are 'osmoregulators', maintaining the osmotic concentration of their body fluids at a level independent of that of the surrounding medium.

Refs.: [i] *Pure Appl Chem* (1996) 68:1488; [ii] Gilles R (1979) *Mechanisms of osmoregulation in animals: maintenance of cell volume*. Wiley, New York; [iii] Strange K (1993) *Cellular and molecular physiology of cell volume regulation*. CRC Press, Boca Raton

MHer

Osmotic pressure — Π is the pressure that must be exerted to maintain osmotic equilibrium between a solution and a pure solvent separated by a \rightarrow *membrane* or \rightarrow *diaphragm*, permeable only for the solvent. The osmotic pressure thus prevents or stops the passage of the solvent through a semipermeable membrane from solvent to solution side, see: \rightarrow *osmosis*. In an ideal dilute solution, the osmotic pressure is related to the solute concentration (gradient) c , and the system's temperature T , known as Van't Hoff equation (\rightarrow *Hoff, Jacobus Henricus van't*): $\Pi = \frac{n}{V}RT = cRT$ (R is the \rightarrow *gas constant*). It can be intuitively, although not correctly, interpreted as the pressure of the solvent molecules inside the solution, which they exert on the membrane. For an ideal diluted solution, Π equals the theoretical gas pressure of the solute, if it would, as gas, inflate into the same volume V at the same temperature T . The osmotic pressure can be experimentally determined. The osmotic driven diffusion of the solvent into the cell leads to an increase of the solvent capillary line in a rising tube. From the capillary height, i.e., the difference of the menisci at the beginning and the end of the osmosis process, the resulting o.p. Π can be derived via the hydrostatic pressure Δp_h as: $\Pi = \Delta p_h = \rho g \Delta h$, where ρ is the density of the solvent, g the gravitational constant, and Δh the difference (rising) in the liquid capillary tube, due to the influence of the osmotic pressure. The osmotic pressure is, as a colligative property, related to the concentration of solute particles only. Thus, it is usually directly proportional to the concentration, and may be used to determine the molecular weight of unknown solutes.

Refs.: [i] van 't Hoff JH (1887) *Z phys Chem* 1:481; [ii] Aseyev GG (1998) *Electrolytes, equilibria in solutions and phase equilibria: calculation of multicomponent systems and experimental data on the activities of wa-*

ter, vapor pressures, and osmotic coefficients. Begell House Publishers, New York

MHer

Osteryoung, Robert Allen



(Jan. 20, 1927, Cleveland, Ohio, USA – Aug. 10, 2004, Raleigh, NC, USA) Osteryoung received his bachelor's education at Ohio University and his Ph.D. at the University of Illinois. He was professor and Chairman of the Chemistry Department at Colorado State University, a professor at the State University of New York at Buffalo and research professor and Chair of the Department of Chemistry of North Carolina State University. He published about 225 original scientific papers, and was especially known for his papers on double potential step \rightarrow *chronocoulometry*, \rightarrow *square-wave voltammetry*, and room-temperature molten salt electrochemistry. He also initiated computer-controlled electrochemical measurements, which helped in developing and optimizing \rightarrow *pulse voltammetry*. He served as an Associate Editor for the journal *Analytical Chemistry*.

Ref.: [i] Stojek Z (2005) *Electroanalysis* 17:1339

ZS

Osteryoung square-wave voltammetry — The protocol of \rightarrow *square-wave voltammetry* developed by \rightarrow *Osteryoung* is based on a square-wave potential train with a frequency that for each forward potential pulse the DC electrode is stepped in the same direction by one increment, i.e., one step of the DC staircase ramp.

Refs.: [i] Osteryoung J, O'Dea JJ (1986) *Square-wave voltammetry*. In: Bard AJ (ed) *Electroanalytical chemistry*, vol. 14. Marcel Dekker, p 209; [ii] Bond AM (1980) *Modern polarographic methods in analytical chemistry*. Marcel Dekker, pp 391–399; [iii] Lovrić M (2002) In: Scholz F (ed) *Electroanalytical methods*. Springer, Berlin, pp 111–136; [iv] Mirčeski V, Komorsky-Lovrić Š, Lovrić M (2007) *Square-wave voltammetry*. In: Scholz F (ed) *Monographs in Electrochemistry*. Springer, Berlin

FS

Ostwald, Friedrich Wilhelm



(Copyright: Nobel Foundation)

(Sep. 2, 1853, Riga, Russian Empire, now Latvia, – Apr. 4, 1932, Großbothen, near Leipzig, Germany) Ostwald studied chemistry at the University of Dorpat (now Tartu, Estonia) from 1872–75. In 1877 he was admitted as unpaid academic lecturer at Dorpat University, and in 1881 he became Professor of Chemistry at the Polytechnicum in Riga. Ostwald was one of the principle founders of physical chemistry, who organized physical chemistry into a nearly independent branch of chemistry [i, ii]. He won the Nobel Prize in Chemistry (1909) in recognition of his work on catalysis and for his investigations of the fundamental principles governing chemical equilibria and rates of reactions (→ *kinetics*). He is best known to electrochemists for the theory of electrolyte solutions. In 1887 he founded the first journal of physical chemistry (*Zeitschrift für physikalische Chemie*). Ostwald wrote an influential book on the history of electrochemistry [iii]. Ostwald created a famous school of chemists, and physico-chemists among his famous pupils are → *Arrhenius*, van't → *Hoff*, → *Nernst*, *Tammann*, and *Wislicenus*.

Refs.: [i] Zott R (2003) *Angew Chem Int Ed* 42:3990; [ii] (1966) *Nobel lectures, chemistry 1901–1921*. Elsevier, Amsterdam; [iii] Ostwald W (1896) *Elektrochemie. Ihre Geschichte und Lehre*, Veit Comp. Leipzig; (Engl transl: Ostwald W (1980) *Electrochemistry. History and theory*, 2 vols. Amerind Publ, New Delhi)

EK

Ostwald, Wolfgang (Carl Wilhelm)



(May 27, 1883, Riga, Russian Empire, now Latvia – Nov. 22, 1943, Dresden, Germany) Wolfgang Ostwald is the son of → *Ostwald, Friedrich Wilhelm*. He studied biology in Leipzig (Germany) where he received his Ph.D. in 1904 and habilitated in 1907 for biology. One of his teachers was W.F.P. Pfeffer who was the first to measure the osmotic pressure of solutions with the so-called Pfeffer cell. Wo. Ostwald's main claim to fame is the establishment of colloid science as an independent branch of science, by editing a journal on → *colloids* and a series of handbooks.

FS

Ostwald's dilution law — A weak → *electrolyte* is dissociated incompletely upon dissolution in a solvent. The chemical equilibrium of dissociation of a weak acid HA into protons and acid anions is described by:

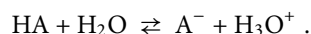

The equilibrium constant (see also → *acidity constant*) is

$$K_a = \frac{a_{\text{A}^-} a_{\text{H}_3\text{O}^+}}{a_{\text{HA}}}$$

At very low concentrations → *activities* can be assumed to be equal to the concentrations *c* because the → *activity coefficients* will approach unity:

$$K_a = \frac{c_{\text{A}^-} c_{\text{H}_3\text{O}^+}}{c_{\text{HA}}}$$

Obviously the degree of dissociation α (or degree of protolysis) must be concentration dependent. The first attempt to describe the → *conductivity* vs. concentration dependence of weak electrolytes was reported by → *Ostwald, F.W.* Using the degree of dissociation α (or degree of protolysis) the concentrations in the solution containing a total concentration of electrolyte *C* are:

$$c_{\text{A}^-} = c_{\text{H}_3\text{O}^+} = \alpha C$$

and

$$c_{\text{HA}} = (1 - \alpha)C.$$

Substitution into the equilibrium equation yields:

$$K_a = \frac{\alpha^2 C}{(1 - \alpha)}.$$

At small values of α this can be simplified

$$\alpha \sqrt{C} = \sqrt{K_a}.$$

At infinite dilution a weak electrolyte will be completely dissociated. Thus the conductance Λ^0 at infinite dilution can be associated with complete dissociation and $\alpha = 1$. Assuming that the decrease of Λ_{eq} ($\Lambda_{\text{eq}} = \Lambda/z$) with increasing concentration is caused mostly by the decrease of the degree of dissociation, α can be defined as

$$\alpha = \frac{\Lambda_{\text{eq}}}{\Lambda^0}.$$

Combination and rearrangement yield

$$\Lambda_{\text{eq}} \sqrt{C} = \sqrt{K_a} \Lambda^0 = \text{const}.$$

The hyperbola-like relationship between Λ_{eq} and concentration C is obvious:

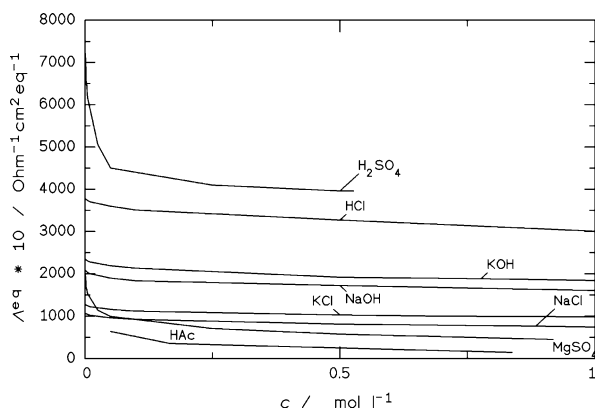

Ostwald's dilution law — **Figure.** Plot of Λ_{eq} vs. concentration c for aqueous solutions of various electrolytes. (see also → *Kohlrausch square root law*)

Ref.: [i] Kortüm G (1953) *Z Elektrochem* 57:874

RH

Ostwald-Walden rule → *Walden's rule*

Outer (or external) electric potential → *potential*, subentry → *outer (or external) electric potential*

Overcharging — Charging a secondary cell or → *battery* beyond the point where it is fully charged. Each rechargeable battery has an ultimate → *charge capacity*, beyond which forcing further charging results in overcharging and damage. In most cases the end-point for charging is set at a certain → *cut-off voltage* or, as in nickel-cadmium (→ *Ni-Cd cell*) and nickel metal-hydride (→ *Ni-MH cell*), there is a unique voltage versus charge response, in addition to cut-off voltage. Any further charging results usually in irreversible dissolution or decomposition of the active materials and electrode corrosion, as well as solution decomposition.

Refs.: [i] Linden D (1994) *Sealed nickel-metal hydride batteries*. In: Linden D (ed) *Handbook of batteries*, 2nd edn. McGraw-Hill, New York, 33.17–33.24; [ii] Crompton TR (2000) *Battery reference book*, 3rd edn. Newnes, Oxford, p 1/26, 2/19, 3/3–3/4, 4/6–4/9, 19/4–19/6 and Glossary YG

Overpotential → *potential*, subentry → *overpotential*

Oversaturation — A thermodynamically unstable system that contains more of the dissolved material than would be dissolved by that solvent at equilibrium. It can also refer to a vapor of a compound whose partial pressure is higher than the vapor pressure of that compound at that temperature. Small particles can trigger the precipitation of dissolved material or the condensation of vapor in oversaturated systems since they provide a suitable interface to start the formation of the new phase [i].

See also → *crystallization overpotential (polarization)*, → *nucleation and growth kinetics*, → *equilibrium forms of crystals and droplets*, → *half-crystal position*, → *Kaischew*, → *metal deposition*, → *supersaturation*, → *Stranski*, → *Zel'dovich*.

Ref.: [i] Palmer DA, Fernandez-Prini R, Harvey AH (2004) *Aqueous systems at elevated temperatures and pressures. Physical chemistry in water, steam and hydrothermal solutions*. Academic Press, London

FG

Overvoltage → *potential*, subentry → *overpotential*

Oxidant — A substance, also called oxidizing agent, that oxidizes another substance by accepting electrons from this reagent to establish a lower energetic state. The oxidant itself is reduced during this reaction. Hence, oxidants are electron acceptors in → *redox reactions*. A measure of the oxidation power is the → *redox potential*.

Important oxidants (beside → *oxygen*) are permanganate, peroxides, chlorine, or iodine, and, most importantly in electrochemistry, an electrode that serves as electron sink (→ *anode*).

BM

Oxidation — is, in a narrow sense, the reaction of a substance with \rightarrow oxygen. During this reaction, electrons are transferred from the substance to the oxygen. Oxygen itself is being reduced. (For example, iron may react with oxygen to form iron oxide, also called rust.)

In a general sense, oxidation is a reaction in which a substance (molecule, atom or ion) loses electrons. These are transferred to another substance called \rightarrow oxidant. The oxidation number of the substance being oxidized increases. Oxidation and reduction always occur simultaneously. In nature, oxidation reactions play an important role, e.g., in \rightarrow respiration, metabolic processes, photooxidation, \rightarrow corrosion and combustion, and, most importantly in electrochemistry, oxidation processes proceed at \rightarrow anodes.

BM

Oxidation–reduction potential (redox potential) —

A measure of the oxidation/reduction capability of a solution (liquid or solid) measured with an \rightarrow inert electrode. For \rightarrow electrochemically reversible systems it is defined by the \rightarrow Nernst equation. For \rightarrow electrochemically irreversible systems it is a conditional measuring quantity, i.e., depending on the experimental conditions. See also \rightarrow potential, \rightarrow redox potential.

BM

Oxide layers — Thin oxide layers on \rightarrow electrode surfaces govern the properties and heterogeneous kinetics of many metal electrodes. For most conditions a metal surface is not free of any layer. Only at very negative \rightarrow potentials, i.e., during hydrogen evolution they may be free of any oxide. Reactive metals are mostly covered by an oxide or hydroxide film if the potential is positive enough so that they may form according to their thermodynamic properties. Also semi-noble metals and noble metals form an oxide layer if the applied potential is sufficiently positive. Pt and Au are covered by very thin oxide layers at potentials $E > 0.7$ V or $E > 1.0$ V respectively. Thus \rightarrow oxygen evolution occurs even in the case of these metals on a oxide-covered surface. The oxygen ions of these layers may even participate in the mechanistic details of oxygen evolution. At sufficiently negative potentials the metal surfaces are free of oxide films as, e.g., during cathodic \rightarrow hydrogen evolution. These layers are often highly soluble in acidic electrolytes, e.g., in the case of Cu, Ag, Al, Mo, so that they are not stable enough and thus are not protective and the metal is dissolved without showing \rightarrow passivity. In weakly acidic or alkaline solutions these films will form and may protect the metal underneath. In other cases these oxides

dissolve extremely slowly in strongly acidic electrolytes although they are not in dissolution equilibrium. Thus they are protective and cause passivity at low pH as, e.g., in the case of Fe, Cr, Ni, Ti above their related passivation potential. The potentials of oxide formation may be calculated from thermodynamic data which are compiled in potential-pH diagrams, the so-called \rightarrow Pourbaix diagrams [i] and their \rightarrow standard potentials are given in the literature [ii]. Many metals form a monolayer of oxide or hydroxide at potentials much more negative than their thermodynamic value of oxide formation. These layers may be seen as \rightarrow chemisorption layers and are often a precursor of the three-dimensional oxide films formed at more positive potentials [iii, iv]. They often already have the atomic structure of the three-dimensional films.

The chemical composition of many anodic oxide layers has been successfully studied in detail by qualitative and quantitative XPS analysis. A specimen transfer within a closed system allows the study of these oxides without chemical changes and uncontrolled growth by oxidation due to air access. The start of oxide growth with a sputter-cleaned and thus oxide-free metal surface allows the investigation of very thin films formed at negative potentials or short oxidation times, including the quantitative evaluation of lower valent species as, e.g., Fe(II). Thus, reliable XPS investigations become possible with specimen preparations at very low potentials and time-resolved measurements of oxide growth starting in the millisecond range [i, v, vi] (see \rightarrow surface analytical methods).

Due to the presence of oxide layers on many electrode surfaces, their electronic properties are of decisive importance for \rightarrow charge transfer processes and their photoelectrochemical behavior. They may be insulating as in the case of Al, Nb, or Ta-oxide. These metals may be charged to more than 100 V without oxygen evolution due to their insulating properties which prevents electron transfer. Often oxide layers on metals are \rightarrow semiconductors and allow electron exchange during electrochemical reactions of redox systems and thus also permit their imaging by tunnel currents with STM. Their band gap has been studied by \rightarrow photoelectrochemistry, i.e., the wavelength dependence of the photocurrent. The flat band potential has been determined by the potential dependence of the photocurrent or by a \rightarrow Schottky–Mott evaluation of capacity measurements. The Schottky–Mott plot yields also the doping of the semiconducting oxide layers, which is often high in the range of 10^{19} cm⁻³. UPS measurements provide in addition the energy of the valence band edge with refer-

ence to the vacuum energy scale or the standard hydrogen electrode. One thus has in some cases a good insight into the electronic properties of these oxide layers. Details for anodic oxide layers on Cu are presented in [iii]. An overview of the photoelectrochemical properties of passive layers is given in [vii].

Refs.: [i] Pourbaix M (1966) *Atlas of electrochemical equilibria in aqueous solutions*. Pergamon, Oxford; [ii] Vetter KJ (1967) *Electrochemical kinetics*. Academic Press, New York, 751, 753; [iii] Strehblow HH (2003) *Passivity of metals*. In: Alkire RC, Kolb DM (eds) *Advances in electrochemical science and engineering*. Wiley-VCH, Weinheim, pp 271–374; [iv] Kunze J, Maurice V, Klein LH, Strehblow HH, Marcus P (2003) *Electrochim Acta* 48:1157; [v] Haupt S, Collisi U, Speckmann HD, Strehblow HH (1985) *J Electroanal Chem* 194:179; [vi] Haupt S, Calinski C, Hoppe HW, Speckmann HD, Strehblow HH (1986) *Surf Interface Anal* 9:357; [vii] Di Quareto E, Santamaria M, Sunseri C (2006) *Photoelectrochemical techniques in corrosion studies*. In: Marcus P, Mansfeld F (eds) *Analytical methods in corrosion science and engineering*. Taylor Francis, Boca Raton, pp 697–732

HHS

Oxidized ruthenium titanium anode → *dimensionally stable electrodes*, and → *electrode materials*, subentry → ORTA

Oxygen — (also: dioxygen to distinguish O_2 from ozone, O_3). The most abundant element in the environment (atmosphere [ca. 21%], sea, upper 16 km of the crust of the earth) with approx. 49.5%. Of fundamental importance in biological processes of energy conversion (breathing, aerobic metabolism). In electrochemistry oxygen is encountered frequently, sometimes necessary, sometimes undesired or disturbing:

1. Oxygen is the oxidant in most → *fuel cells* and in all → *metal-air batteries*
2. Oxygen is involved in most metal → *corrosion* processes
3. Oxygen is a product of → *water electrolysis*
4. Oxygen may interfere with interfacial electrochemical processes when not completely removed (purged) from the electrolyte solution

ad 1: Oxygen can be reduced to water in a cathodic reaction, the standard potential of this electrode is $E^\ominus = 1.229\text{ V}$. The kinetics of this reaction are sluggish both in alkaline and acidic electrolyte solution, the rate of reaction is acceptable only with suitable catalysts [i, ii]. In

alkaline solution most catalysts support formation of hydrogen peroxide only (→ *Berl reaction*); in order to remove unwanted radicals formed during decomposition of hydrogen peroxide high catalytic peroxide decomposition activity (catalase activity) is required, too. The actual mechanism of oxygen reduction is complicated, it depends on pH, type of catalyst, and electrolyte solution composition. In aprotic solvents oxygen is reduced to superoxide anion radicals $\bullet O_2^-$.

ad 2: The cathodic process supporting the anodic metal dissolution reaction is either hydrogen evolution (acid corrosion) which occurs only infrequently. In the majority of metal corrosion reactions oxygen reduction is the cathodic process. In addition, oxygen is finally present in most oxidic corrosion products. Thus → *corrosion inhibition* deals frequently with suppression of oxygen supply to a potential corrosion site and with inhibition of the cathodic reduction reaction by, e.g., surface-active inhibitors.

ad 3: Although industrial production proceeds predominantly via fractionated distillation of liquefied air, generation of oxygen by water electrolysis is infrequently encountered (e.g., when cheap electrical energy is available, as a byproduct of electrolytic hydrogen generation). Various processes (e.g., Zdansky–Lonza process of an aqueous solution of KOH at elevated pressure $p = 30\text{ bar}$) are available. The mechanism of oxygen evolution from water is complicated, it depends on the type of catalyst (metal, metal oxide, etc.), pH, and composition of solution. → *Chemisorbed oxygen* as well as oxidic intermediates are encountered.

ad 4: In all electrochemical investigations involving solvent-based electrolyte solutions the presence of oxygen is a nuisance. At most electrode materials oxygen will be reduced to hydrogen peroxide, which in turn establishes a redox system in the electrolyte solution causing current peaks in → *cyclic voltammetry* or additional current steps in → *polarography*. In addition oxygen might react homogeneously with reaction intermediates of, e.g., fuel oxidation reactions causing erroneous observations of products which are actually formed by undesired chemical reactions instead of electrochemical heterogeneous reactions. Oxygen can be removed from most electrolyte solutions by carefully purging the solution with a stream of nitrogen or argon which itself has been carefully deoxygenated by suitable catalytic converters or oxygen getters. In most aqueous electrolyte solutions purge times of 15 min shall be sufficient provided that the purge gas is finely distributed (e.g., by a coarse glass

frit) and transported to all parts of the electrochemical cell. Feed lines for purge gas shall be constructed of metal (copper or stainless steel) because most polymers have a considerable permeability for oxygen. In addition numerous polymers might release volatile plastizisers.

Preparation and study of solutions where rigorous protection from oxygen is needed is often carried out in a glove box or on a vacuum line (→ *glove box technique*).
 Refs.: [i] Hoare JP (1974) Oxygen (electrochemistry). In: Bard AJ (ed) *Encyclopedia of electrochemistry of the elements*, vol. 2. Marcel Dekker, New York, p 192; [ii] Yeager E (1986) *J Mol Catal* 38:5; [iii] Sawyer DT, Sobkowiak A, Roberts JL (1995) *Electrochemistry for chemists*. Wiley, New York; [iv] LHer M (2006) *Redox properties, electrochemistry of oxygen*. In: Bard AJ, Stratmann M, Scholz F, Pickett CJ (eds) *Inorganic electrochemistry*. *Encyclopedia of electrochemistry*, vol. 7a. Wiley-VCH, Weinheim, pp 119

RH

Oxygen anion conductors → *solid electrolyte*

Oxygen, chemisorbed → *chemisorption of oxygen*

Oxygen conducting solid electrolyte → *solid electrolyte*

Oxygen pumps — are solid-electrolyte devices for generation of high-purity oxygen, oxygen removal, → *coulometric titration*, and precise control of oxygen → *activity* levels in various media, usually gases. The pump should comprise, at least, one dense membrane of an oxygen ion-conducting → *solid electrolyte*, two electronically-conducting → *electrodes* and current collectors. The oxygen transfer through the electrochemical cell is driven by a DC voltage applied to the electrodes. Examples of the electrolytes are → *stabilized zirconia*, doped → *cerium dioxide* and → *BIMEVOX*.

See also → *oxygen* and → *electrochemical gas compressors*.

Refs.: [i] Ciacchi FT, Badwal SPS, Zelizko V (2002) *Solid State Ionics* 152–153:763; [ii] Dyer PN, Richards RE, Russek SL, Taylor DM (2000) *Solid State Ionics* 134:21

VK

Oxygen sensors — Device for measurement of → *oxygen* concentration or activity. See → *Clark cell*, → *lambda-probe*.

Ref.: [i] Sreedharan OM, Mallika C, Gnanamoorthy JB (1986) *Bull Electrochem* 2:297

RH

P

Packed bed electrode — A static three-dimensional → *electrode* consisting of a restrained bed of electronically conducting particles in continuous intimate contact. Packed Bed Electrodes (PBEs) present high electroactive area per unit electrode volume and moderately high → *mass transport* characteristics (the limiting current at a PBE may exceed 100 times the one observed at a two-dimensional electrode of the same volume).

Many configuration designs are possible for cells using PBE, depending upon: the electrolyte flow conditions (trickle or flooded); the electrical current feeders/collectors connections to the bed (monopolar or bipolar); the relative directions of current and electrolyte flows (parallel or perpendicular); the counter electrode type (two- or three-dimensional); the electrode geometry (cylindrical, rectangular, or profiled, where the cross-section area and/or the particles' sizes are changed along the cell).

PBE can be used for the destruction of organic compounds, regeneration of hexavalent chromium, production of hydrogen peroxide, but their major application is in metal removal from dilute solutions. In this situation, the choice of small-sized particles is tempting for the increase of process efficiency; nevertheless, a compromise must be considered since very fine particles also decrease the bed permeability causing problems to the electrolyte flow.

To improve the porosity and also the ionic → *conductivity*, it is useful to formulate the bed by mixing the electronically conducting particles (graphite or metallic granules) with ionic conducting ones (for example, ionic resin beads). In extremely adverse operative conditions, high current density and low bed voidance, the PBE may be completely plugged with metal in their interstices. To recover the deposited metal, the packed bed can be removed from the cell by vacuuming or subject to dissolution in a small volume of electrolyte for obtaining a concentrate solution.

The principal drawbacks of PBE are: possibility of channeling; uneven distribution of the electric fields; need for electrical currents near the limiting value to achieve large conversion yield; efficiency lowering with the increase in bed thickness.

Refs.: [i] Walsh FC (1993) *A first course in electrochemical engineering*. The Electrochemical Consultancy, Romsey, Hants; [ii] Pletcher D, Walsh FC (1990) *Industrial electrochemistry*, 2nd edn. Chapman and Hall, Lon-

don; [iii] Rajeshwar K, Ibanez JC (1997) *Environmental electrochemistry, fundamentals and applications in pollution abatement*. Academic Press, San Diego

LMA

Palladium → *electrode materials*

Paraffin impregnated graphite electrode (PIGE) → *electrode* prepared from graphite rods by impregnation with melted paraffin under vacuum. These electrodes are not permeated by aqueous solutions and can be used for solution studies, as well as for immobilizing microparticles and microdroplets to study their electrochemistry. See also → *carbon*, → *voltammetry of immobilized microparticles*.

Ref.: [i] Scholz F, Schröder U, Gulaboski R (2005) *Electrochemistry of immobilized particles and droplets*. Springer, Berlin

FS

Parallel circuit → *circuit*

Parallel plate and frame cell — This → *electrolysis* cell type has been developed since the 1970s, and reliable cells from laboratory up to industrial production scale in divided or undivided form are commercially available. Parallel plate and frame cells comprise interelectrode gaps of 1 to 12 mm. They can be used as monopolar (A) or → *bipolar electrode* (B) arrangement, see figure.

In type (A), each electrode is connected, and both faces of the electrode have the same polarity, while in type (B), i.e., bipolar connections, only the end plates are contacted, and the other electrodes are polarized in the electric field, so that two faces of the electrodes, therefore, have different polarities. Monopolar connected cells require a low voltage and a high current (cell voltage plus cell current multiplied by the number of cells) to be supplied by a DC → *rectifier*. The current path through the electrodes is rather long, and electrodes with a high

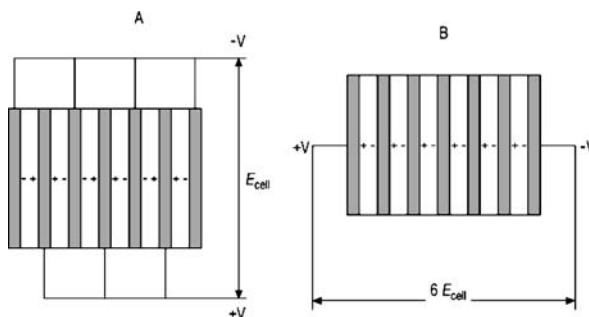

Parallel plate and frame cell — Figure

conductivity have to be used. In case of a bipolar connection, the cell current plus the cell voltage multiplied by the number of cells has to be supplied, therefore, a lower current but a high voltage is required. Less-conducting electrode materials can be used, since the current path through the electrodes is small.

Ref.: [i] Steckhan E (2002) *Organic electrochemistry*. In: *Ullmann's encyclopedia of industrial chemistry*, 6th edn. Wiley-VCH

MHer

Parsons and Zobel plot — In several theories for the electric \rightarrow *double layer* in the absence of specific adsorption, the interfacial \rightarrow *capacity* C per unit area can formally be decomposed into two capacities in series, one of which is the Gouy–Chapman (\rightarrow *Gouy*, \rightarrow *Chapman*) capacity C_{GC} : $1/C = 1/C_H + 1/C_{GC}$. The capacity C_H is assumed to be independent of the electrolyte concentrations, and has been called the inner-layer, the \rightarrow *Helmholtz*, or Stern layer capacity by various authors. In the early work by Stern, C_H was attributed to an inner solvent layer on the electrode surface, into which the ions cannot penetrate; more recent theories account for an extended boundary region. In a Parsons and Zobel plot, C_H is determined by plotting experimental values for $1/C$ vs. $1/C_{GC}$. Specific adsorption results in significant deviations from a straight line, which invalidates this procedure.

Ref.: [i] Parsons R, Zobel FGR (1965) *J Electroanal Chem* 9:333

WS

Partial current (density) — The partial current concept has been introduced by \rightarrow *Erdey-Grúz* and \rightarrow *Volmer* [i], i.e., they considered \rightarrow *anodic partial current* (I_a) and \rightarrow *cathodic partial current* (I_c) in order to interpret the current (I) – potential (E) function (see \rightarrow *Erdey-Grúz–Volmer equation*).

When single \rightarrow *electrode reaction* occurs, the current can be split into two parts

$$I = I_a + I_c \quad (1)$$

I_a being positive and I_c negative.

The same relationship can be given also for the respective current densities:

$$j = j_a + j_c \quad (2)$$

When more than one reaction is significant the reactions may be numbered and the numbers used as subscripts: $I_{1,a}$, $I_{1,c}$, $I_{2,a}$ etc. [ii]. Then

$$I = \sum_i I_{i,a} + \sum_i I_{i,c} \quad (3)$$

When the reaction is at equilibrium

$$I_o = I_a = -I_c \quad (4)$$

where I_o is the exchange current of the electrode reaction ($I_o / A = j_o$ where j_o the \rightarrow *exchange current density*).

For an electrode at equilibrium at which only one reaction is significant $I = 0$.

When appreciable, contributions to the total anodic and/or cathodic partial currents are made by species belonging to two or more different redox couples, but the total current is zero, i.e.,

$$I = \sum_i I_i = 0 \quad (I_i \neq 0) \quad (5)$$

where I_i is the partial current of reaction i

$$I_i = I_{i,a} + I_{i,c} \quad (6)$$

the summation in Eq. (5) contains appreciable contributions from at least two reactions. In this case a \rightarrow *mixed potential* may develop. A typical example is the dissolution (\rightarrow *corrosion*) of metals, when the $I_{1,a}$ belongs to oxidation of the metal, while $I_{2,c}$ corresponds to the reduction of O_2 or H^+ ions. If a single electrode reaction occurs at high \rightarrow *overpotentials* ($|\eta| > 0.118/n, V$) one of the partial currents can be neglected, and the reaction takes place in either the anodic or cathodic direction [iii, iv].

Refs.: [i] Erdey-Grúz T, Volmer M (1930) *Z phys Chem* A150:203; [ii] Parsons R (1974) *Pure Appl Chem* 37:503; [iii] Inzelt G (2002) *Kinetics of electrochemical reactions*. In: Scholz F (ed) *Electroanalytical methods*. Springer, Berlin, pp 29–33; [iv] Bard AJ, Faulkner LR (2001) *Electrochemical methods*, 2nd edn. Wiley, New York, pp 98–103

GI

Partial pressure — Symbol p_B , defined as $p_B = y_B p$ (y_B mole fraction of B, p total pressure). Partial pressure and \rightarrow *fugacity* are sometimes used as ‘concentration-like’ measures for gaseous compounds, e.g., in case of gas electrodes.

Ref.: [i] Quack M, Frey J (eds) (2005) *IUPAC quantities, units and symbols in physical chemistry*, 3rd edn. *Pure Appl Chem Manuscript ID PAC-REC-05-11-10*

FS

Passivation — Metals usually dissolve in acidic electrolytes when their electrode potential becomes more positive than the value of the related \rightarrow *Nernst equilibrium* \rightarrow *potential* of the metal/metal ion electrode. The dissolution current density increases exponentially with

the potential according to the \rightarrow Butler–Volmer equation and finally becomes \rightarrow diffusion controlled. At sufficiently positive potentials the formation of \rightarrow corrosion products becomes faster than the transfer by diffusion into the bulk \rightarrow electrolyte. As a consequence, a salt film will precipitate at the metal surface with a related potential-independent dissolution current density. In the case of iron in moderately stirred sulfuric acid this value is ca. 300 mA cm^{-2} . When the potential becomes more positive than the passivation potential the current density drops by several orders of magnitude to the range of $\mu\text{A cm}^{-2}$. This effect is caused by the formation of a passivating film which consist of the oxides and hydroxides of the metal under study (see also oxide film (\rightarrow oxide layers)). Figure 1 of the next entry (\rightarrow passivation potential) gives as an example the current density potential curves of three important metals which are the main components of stainless steel. They all show active dissolution, a passive potential range, and a current increase with transpassive dissolution at positive potentials.

Passivation of a metal depends on the properties of its anodic oxides which protect the metal surface and prevent the direct contact to the aggressive electrolyte. Any metal dissolution in the passive state requires the transfer of metal cations from the metal surface across the thin anodic passive layer to the electrolyte. This transfer occurs usually under the influence of a very high \rightarrow electrical field strength in the range of several 10^6 V cm^{-1} , which causes an exponential current/potential relationship from transient measurements similar to the Butler–Volmer equation (high field mechanism). Due to the transfer across this dense and poreless passive layer the passive current density is very small in the range of $\mu\text{A/cm}^{-2}$. The stationary passive current density depends decisively on the solubility and dissolution kinetics of the protecting passive layer. In $0.5 \text{ M H}_2\text{SO}_4$, iron has a stationary dissolution current density of $7 \mu\text{Acm}^{-2}$, in 1 M HClO_4 it is one order of magnitude smaller. This observation demonstrates the complexing properties of the anions within the electrolyte [ii, iii, iv]. The formation of faster dissolving complexes of metal ions with anions increases their transfer from the surface of the oxide matrix to the electrolyte, thus causing the increased passive current density. In this sense complexing of cations by chloride or other halides is the main chemical reason for breakdown of passivity and localized corrosion, i.e. \rightarrow pitting corrosion [iii, iv]. The dissolution kinetics of cations depends also on the pH of the solution. This has been explained by the \rightarrow pH dependence of the potential drop at the oxide/electrolyte interface which is determined by the \rightarrow equilibrium potential for the forma-

tion of OH^- or O^{2-} ions from water [i, ii]. With increasing pH this potential drop decreases which influences the cation transfer which then gets slower. When the pH reaches close to the dissolution equilibrium value of the oxide or hydroxide, cation transfer is no longer possible and the metal is passive due to the formation of a layer which is insoluble within the contacting electrolyte. In consequence one has to distinguish two causes for passivity: (a) The anodic oxide is in dissolution equilibrium and cannot dissolve or (b) the transfer of the cations from the oxide surface to the electrolyte is so slow that the dissolution rate becomes extremely small although the oxide is far from its dissolution equilibrium. The first case is found for metals like aluminum, copper, silver, or cobalt. They are not protected in strongly acidic electrolytes. The second case holds for metals like iron, nickel, or chromium in acidic electrolytes (Fig. 1 of the next entry (\rightarrow passivation potential)). They are also passive in alkaline solutions, where the dissolution equilibrium is established for their oxides. Chromium is special in so far as its oxide dissolves in acidic electrolytes extremely slowly even in the presence of complexing anions like chloride. Therefore, this metal is well protected by its passive layer and does not pit at all. This high stability of the Cr_2O_3 layer protects even in the case of Cr-alloys as FeCr or FeNi alloys or stainless steel (Fe18Cr8Ni). The accumulation of Cr oxide within the passive layer gives a good protection and prevents localized corrosion or shifts at least the pitting potential to more positive values [iii, iv].

Under \rightarrow open-circuit conditions a possible passivation depends seriously on the environment, i.e., the pH of the solution and the potential of the redox system which is present within the electrolyte and its kinetics. For electrochemical studies redox systems are replaced by a \rightarrow potentiostat. Thus one may study the passivating properties of the metal independently of the thermodynamic or kinetic properties of the redox system. However, if a metal is passivated in a solution at open-circuit conditions the cathodic current density of the redox system has to exceed the maximum anodic dissolution current density of the metal to shift the electrode potential into the passive range (Fig. 1 of the next entry (\rightarrow passivation potential)). In the case of iron, concentrated nitric acid will passivate the metal surface whereas diluted nitric acid does not passivate. However, diluted nitric acid may sustain passivity if the metal has been passivated before by other means. Thus redox systems may induce or only maintain passivity depending on their electrode potential and the kinetics of their reduction. In consequence, it depends on the characteristics of metal disso-

lution and the redox system whether a metal will passivate in a given environment, i.e., under open-circuit conditions. See also → *Flade*.

Refs.: [i] Strehblow HH (2003) *Passivity of metals*. In: Alkire RC, Kolb DM (eds) *Advances in electrochemical science and engineering*. Wiley-VCH, Weinheim, pp 271–374; [ii] Vetter KJ, Gorn F (1973) *Electrochim Acta* 18:321; [iii] Strehblow HH (2002) *Mechanisms of pitting corrosion*. In: Marcus P (ed) *Corrosion mechanisms in theory and practice*. Marcel Dekker, New York, pp 243–285; [iv] Strehblow HH (2003) *Pitting corrosion*. In: Bard AJ, Stratmann M, Frankel GS (eds) *Corrosion and oxide films*. *Encyclopedia of electrochemistry*, vol. 4. Wiley, Weinheim, 337

HHS

Passivation potential — A metal turns passive if the electrode potential is shifted above the passivation potential E_p into the passive range of the → *polarization* curve (Fig. 1). This critical potential depends on the thermodynamic properties of the metal. In many cases it equals the value deduced from the thermodynamic data for the formation of an oxide layer of the metal in aqueous electrolytes according to Eq. (1). This reaction is → *pH* dependent by -0.059 V/pH . In some cases it corresponds to the oxidation of a lower valent to a higher valent oxide (Eq. (2)). For iron the passivation potential in acidic electrolytes has been explained by Eq. (3).

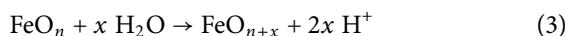
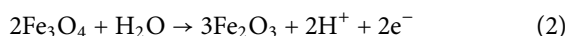

$$E_{F2} = 0.58 - 0.059 \text{ pH} \quad (4)$$

Equation (1) leads with the thermodynamic values of any of the possible oxides at pH 0 to a value slightly more

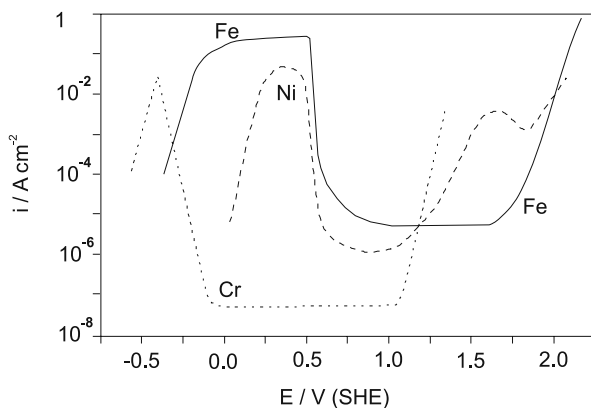

Passivation potential — **Figure 1.** Polarization curves of three metals in 0.5 M H_2SO_4 with active dissolution, a passive potential range, and transpassive dissolution and/or oxygen evolution at positive potentials $E_p(\text{Cr}) = -0.2 \text{ V}$, $E_p(\text{Fe}) \approx E_p(\text{Ni}) = 0.6 \text{ V}$ [i]

negative than 0 V. The experimental passivation potential, the so-called → *Flade potential* E_{F2} follows Eq. (4) and is ca. 0.6 V more positive. As a consequence, the passivation potential of Fe in acidic solutions has to be explained by the reaction of Eqs. (2, 3) with thermodynamic data which yield the experimental value [ii]. In alkaline solution passivation occurs at much more negative potentials E_{F1} as predicted by Eq. (4) (Fig. 2) which may be explained with formation of a FeO or Fe_3O_4 layer according to a reaction following Eq. (1). Although the Fe_3O_4 layer dissolves immediately in acidic solutions it is protective in 1 M NaOH because it is insoluble for these conditions. XPS investigation of thin anodic oxide films on Fe in 1 M NaOH have shown that at $E = -0.24 \text{ V}$ the Fe(II) content of the layer is changed to Fe(III) which

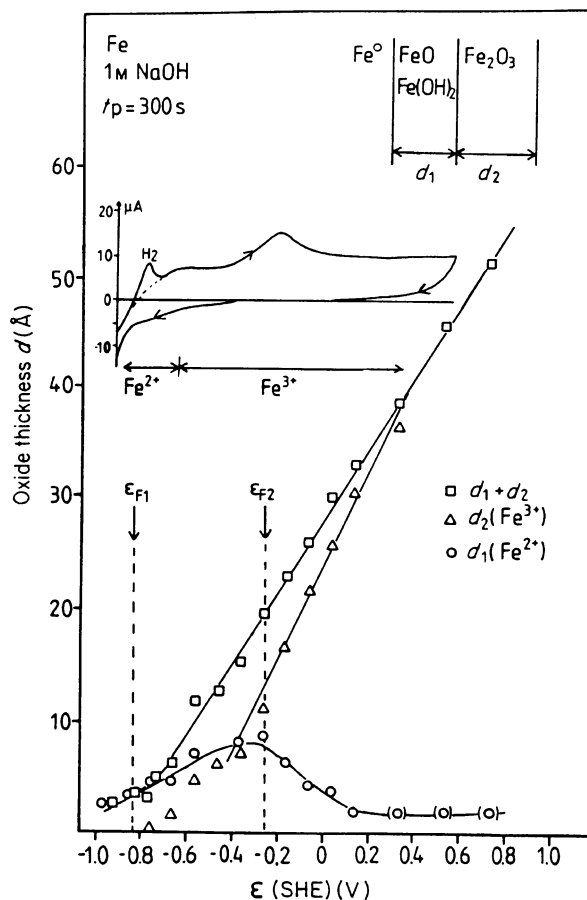

Passivation potential — **Figure 2.** Evaluation of XPS data on the chemical structure of the passive layer on Fe formed for 300 s in 1 M NaOH as a function of potential with a two-layer model Fe(II)/Fe(III). Insert shows the polarization curve with oxidation of Fe(II) to Fe(III) at the Flade potential E_{F2} , indication of soluble corrosion products Fe^{2+} and Fe^{3+} , and passivation potential E_{F1} in alkaline solution [i, iii]

goes along with an anodic peak of the polarization curve (Fig. 2) [i, iii]. This potential is the extrapolated value of the Flade potential of acidic electrolytes following Eq. (4). Thus the XPS investigations in alkaline solution give justification for the interpretation of the Flade potential of iron in acidic solution according to Eq. (2). The average composition of the passive layer at $E = -0.24$ V has been determined to Fe_3O_4 with a change to almost pure Fe_2O_3 up to $E = 0.20$ V (Fig. 3) [i, iii]. However, the details of the XPS analysis suggest a more complex situation with an interpretation by a bilayer structure with an inner Fe(II)-rich and an outer Fe(III)-rich part (Fig. 2) [i, iii] (\rightarrow oxide layers).

\rightarrow potential-pH diagrams, the so-called \rightarrow Pourbaix diagrams present a compilation of the thermodynamic data for all elements and thus help to predict under which conditions a metal is passive or is submitted to active or transpassive dissolution [i, iv]. Usually transpassive dissolution corresponds to the formation of higher valent compounds which are more soluble or are dissolving faster. The higher dissolution of Cr in the transpassive state is related to the formation of soluble CrO_4^{2-} or $\text{Cr}_2\text{O}_7^{2-}$ in alkaline or acidic electrolytes, respectively. As a consequence, Cr is dissolving intensively at potentials $E > 1.0$ V (Fig. 1). However, the predictions of the Pourbaix diagrams have to be taken with caution, because they are based on thermodynamic data only. It depends, in addition to the equilibrium data, also on the kinetic

parameters of a system whether a metal behaves passive or not. Fe, Cr, and Ni should not show passivity in strongly acidic electrolytes, such as 0.5 M H_2SO_4 , or 1 M HClO_4 . However, they are passive when the potential allows the formation of the protecting oxides. When these oxides form, the slow transfer of their cations from the protecting oxide layer to the electrolyte reduces the passive current density to a negligibly small value. These oxides Fe_2O_3 , Cr_2O_3 , or NiO , have sufficiently slow transfer rates of the metal cations from the passive layer to the electrolyte so that they are protective although they are far from the dissolution equilibrium in strongly acidic solutions (Fig. 1).

Refs.: [i] Strehblow HH (2003) *Passivity of metals*. In: Alkire RC, Kolb DM (eds) *Advances in electrochemical science and engineering*. Wiley-VCH, Weinheim, pp 271–374; [ii] Vetter KJ (1967) *Electrochemical kinetics*. Academic Press, New York, 781; [iii] Haupt S, Strehblow HH (1987) *Langmuir* 3:873; [iv] Pourbaix M (1966) *Atlas of electrochemical equilibria in aqueous solutions*. Pergamon, Oxford

HHS

Passive filter \rightarrow analog filter

Passivity — An active metal is one that undergoes oxidation (\rightarrow corrosion) when exposed to electrolyte containing an oxidant such as O_2 or H^+ , common examples being iron, aluminum, and their alloys. The metal becomes passive (i.e., exhibits passivity) if it resists corrosion under conditions in which the bare metal should react significantly. This behavior is due to the formation of an oxide or hydroxide film of limited ionic conductivity (a passive film) that separates the metal from the corrosive environment. Such films often form spontaneously from the metal itself and from components of the environment (e.g., oxygen or water) or may be formed by an anodization process in which the anodic current is supplied by a power supply (see \rightarrow passivation). For example, Al forms a passive oxide film by the reaction

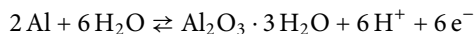

where various solid modifications of hydrated Al_2O_3 can form (hydrargillite is often considered the most stable form) [i]. In electronics and other fields, “passivation” may refer to any protective film deposited on a material to prevent its corrosion, for example, using physical vapor deposition.

The Figure is a schematic polarization curve for a metal exhibiting typical thin-film active-passive behavior (e.g., Ni or Cr in sulfuric acid). Note that this diagram is for a single redox system, namely M/M^+ (i.e.,

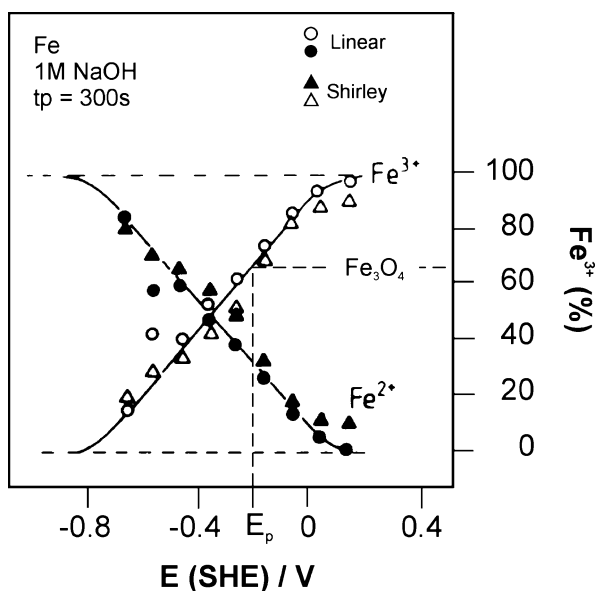

Passivation potential — Figure 3. Evaluation of XPS data of Fig. 2 with an average composition of the oxide layer with composition Fe_3O_4 at $E_p = E_{\text{Fe}2}$ [i, iii]

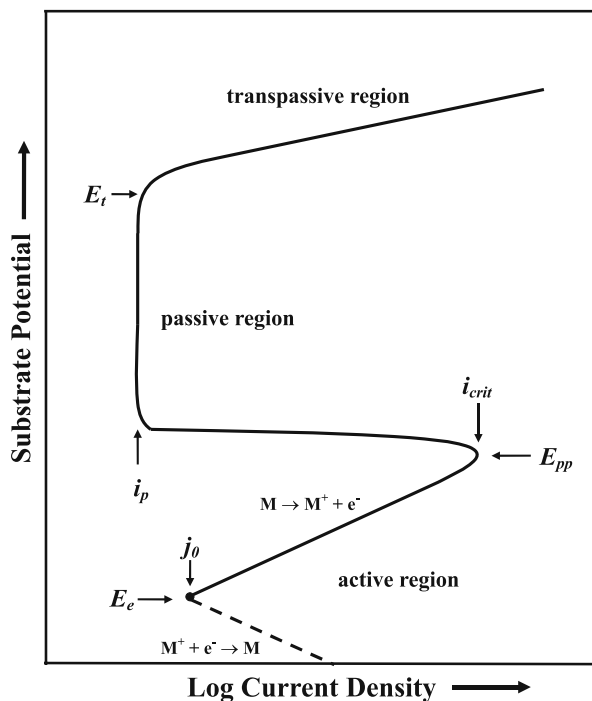

Passivity — Figure

the polarization curves for typical oxidants such as oxygen or H^+ are not shown). The dashed portion of the curve represents the cathodic branch where metal ion reduction occurs. The solid portion of the curve represents the anodic branch along which metal oxidation occurs. The intersection point of these two branches corresponds to the \rightarrow equilibrium potential E_e and the \rightarrow exchange current density j_0 of the M/M^+ redox couple. As the potential is increased positive of E_e , the current density (hence, corrosion rate) increases until a critical passivation potential (E_{pp} , also known as the \rightarrow Flade potential) or a critical current density (i_{crit}) is reached, at which point the current drops to a (usually) much lower value (i_p), signaling the onset of passivation. In the passive region, the current remains low even though a large driving force (positive potential) is applied to the metal. Above some potential E_t , the current again increases as the oxide film dissolves uniformly, often accompanied by oxygen evolution (the transpassive region). Thick film passivity (e.g., Al or Mg in water) differs from that illustrated in the figure in that the precipitous drop in current at E_{pp} is not observed, but rather the current levels off from the linear active branch directly to a plateau current, i_p [i]. Some metals such as Al form rather homogeneous passive (oxide) films, while other metals form duplex or bipolar films consisting of layers with differing

valency or differing hydration. For example, the passive layer on Cu consists of Cu_2O and $CuO/Cu(OH)_2$ while the oxide film on Fe consists of an inner layer of Fe_3O_4 and an outer layer of Fe_2O_3 [i]. In the case of gold, an inner layer of Au_2O_3 and an outer layer of $Au(OH)_3$ have been observed [ii]. Alloys often exhibit complex passive films, with compositions that depend on the passivation conditions. For example, angle-resolved X-ray photoelectron spectroscopy reveals the passive film formed on 316L stainless steel to consist of an outer hydroxide layer (mostly Cr^{3+}) and a duplex inner layer containing mixed oxides of Fe, Cr, Mo, and Ni [iii]. See also \rightarrow Flade. Refs.: [i] Schultze JW, Hassel AW (2006) Passivity of metals, alloys, and semiconductors. In: Bard AJ, Stratmann M, Frankel GS (eds) Corrosion and oxide films. Encyclopedia of electrochemistry, vol. 4. Wiley-VCH, Weinheim, pp 216–270; [ii] Lohrengel MM, Schultze JW (1976) Electrochim Acta 21:957; [iii] Gaben F, Vuillemin B, Oltra R (2004) J Electrochem Soc 151:B595

DT

Paste electrodes \rightarrow electrodes prepared by making a paste from an electron-conducting material and a binder. The binder may be an electrolyte solution or ‘inert’ oils like \rightarrow Nujol. Paste electrodes can be part of batteries [i], where the electroactive material is used to prepare the paste, often with the addition of an inert electron conductor. In \rightarrow electroanalytical chemistry, unmodified and modified \rightarrow carbon paste electrodes are used.

Ref.: [i] Besenhard JO (ed) (1999) Handbook of battery materials. Wiley-VCH, Weinheim

FS

PBD \rightarrow probe beam deflection

PBD maximum (probe beam deflection maximum) — The maximal chronodeflectometric response observed at the time t_{max} in which, the maximum concentration gradient of soluble species is achieved at the probe beam position. The value of t_{max} depends on the beam–electrode distance, on the kind of electrochemical process, and on the \rightarrow diffusion coefficient of soluble species [i]. In consequence, if the probe beam is farther away from the electrode, a longer t_{max} will be involved. Chronodeflectometric responses can show a maximum, a minimum, or both effects, depending on the involved soluble species and on the reaction that takes place at the electrode [ii]. See also \rightarrow chronodeflectometry.

Refs.: [i] Rudnicki JD, Brisard GM, Gasteiger HA, Russo RE, McLaron FR, Cairns EJ, (1993) J Electroanal Chem 362:55; [ii] Barbero CA (2005) Phys Chem Chem Phys 7:1885

FG

$p\varepsilon$ value (also pE , or pe value) — In analogy to the → pH , the $p\varepsilon$ value has been introduced and defined as follows: $p\varepsilon = -\lg a_{e^-}$ where a_{e^-} is supposed to mean the → activity of electrons in solution. This is a misleading (although thermodynamically correct) concept because (i) free electrons do not exist in solution (unusual exceptions are very short-lived solvated electrons in some solvents and rather stable solvated electrons in solvents like liquid ammonia), (ii) because of the nonexistence of free electrons in solution, any redox equilibrium of the kind $Ox + ze^- \rightleftharpoons Red$ (reaction 1) (charges of species omitted) is coupled to another redox equilibrium. The standard system to relate redox equilibria to is the → hydrogen electrode. The law of mass action applied to reaction 1 yields: $p\varepsilon = \frac{1}{z} \log K_1 + \log \frac{a_{Ox}}{a_{Red}}$ with K_1 being the equilibrium constant of reaction 1, and a denoting activities. Since K_1 cannot be determined, instead of it, the equilibrium constant K' of the reaction $Ox + \frac{z}{2}H_2 \rightleftharpoons Red + zH^+$ (reaction 2) is used. It holds that K' equals K_1 because of the thermodynamic convention that the equilibrium constant K_2 of the reaction $1/2H_2 \rightleftharpoons H^+ + e^-$ is arbitrarily set to 1. It follows that $p\varepsilon = (1/z) \log K' + (1/z) \log \frac{a_{Ox}}{a_{Red}}$, $p\varepsilon = p\varepsilon^\ominus + (1/z) \log \frac{a_{Ox}}{a_{Red}}$, $p\varepsilon = \frac{F}{2.303RT} E_{Ox/Red}$, and $p\varepsilon^\ominus = \frac{F}{2.303RT} E_{Ox/Red}^\ominus$. The $p\varepsilon$ values are frequently used in biological and environmental textbooks.

Ref.: [i] Stumm W, Morgan JJ (1996) *Aquatic chemistry*, 3rd edn. Wiley, New York, pp 429

$p\varepsilon$ -log c_i diagrams — The analog of → E -log c_i diagrams; however using → $p\varepsilon$ values instead of the redox potential E .

Refs.: [i] Stumm W, Morgan JJ (1996) *Aquatic chemistry*, 3rd edn. Wiley, New York, pp 429; [ii] Butler JN (1998) *Ionic equilibrium*. Wiley, New York, pp 318

$p\varepsilon$ - pH diagrams — The analog of → E - pH diagrams (→ Pourbaix diagram); however using → $p\varepsilon$ values instead of the redox potential E .

Ref.: [i] Stumm W, Morgan JJ (1996) *Aquatic chemistry*, 3rd edn. Wiley, New York, pp 429

Peak current (in → voltammetry) → voltammetry

Peak height (in → voltammetry) — It is the maximum current in → linear scan voltammetry, → cyclic voltammetry, → staircase voltammetry, → differential staircase voltammetry, → alternating current polarography

and voltammetry, → differential pulse polarography and voltammetry, and → square-wave voltammetry. In all these techniques the peak current is proportional to the bulk concentration of the reactant, regardless of → electrode geometry, the kinetics of electrode reaction, and hydrodynamic conditions in the cell. This is the basis for its analytical application. If a diffusion-controlled reaction is either → reversible or totally → irreversible within a certain interval of scan rates, or frequency, or pulse durations, the peak current depends linearly on the square root of scan rate, or frequency, or the inverse value of pulse duration. For → quasireversible electrode reactions, i.e., for reactions where the apparent reversibility depends on the scan rate, or the other two parameters mentioned above, the peak current is not a linear function of the square root of these parameters. In the case of → surface redox reactions and reactions in → thin-layer cell, which are independent of mass transfer, the peak current of reversible and totally irreversible reactions is linearly proportional to the scan rate, or the other two parameters. For quasireversible reactions this relationship is not linear.

In linear scan voltammetry (LSV) the peak current of fast and reversible electrode reactions controlled by semi-infinite planar → diffusion is given by the following equation [i]:

$$I_{p,c} = 0.4463nFSc_O^* \sqrt{nFDv/RT}$$

FS where c_O^* is the bulk concentration of the reactant, S is the → electrode surface area, n is the number of → electrons, D is the → diffusion coefficient, v is the scan rate (→ potential sweep rate) and F , R , and T have their usual meanings.

The peak current in LSV of totally irreversible electrode reaction of dissolved reactant is given by the following equation:

$$I_p = 0.4958nFSc_O^* \sqrt{\alpha nFDv/RT}$$

where α is a → transfer coefficient.

- In LSV of reversible surface reaction, the peak current is:

$$I_p = n^2 F^2 S v \Gamma / 4RT$$

where Γ is the initial surface concentration of the adsorbed reactant.

- In alternating current polarography of diffusion-controlled, reversible → electrode reaction, the peak current is given by the equation [ii]:

$$I_p = n^2 F^2 S \sqrt{D\omega} U_m c_O^* / 4RT$$

where ω is the angular frequency and U_m is the amplitude of sinusoidal voltage.

- In square-wave voltammetry of diffusion-controlled, reversible, and totally irreversible electrode reactions, the peak current is a linear function of the square root of frequency, but its relationship with square-wave amplitude is not linear.

Refs.: [i] Marken F, Neudeck A, Bond AM (2002) *Cyclic voltammetry*. In: Scholz F (ed) *Electroanalytical methods*. Springer, Berlin, p 51; [ii] Galus Z (1994) *Fundamentals of electrochemical analysis*, 2nd edn. Ellis Horwood, New York, Polish Scientific Publisher PWN, Warsaw; [iii] Bard AJ, Faulkner LR (2001) *Electrochemical methods*, 2nd edn. Wiley, New York; [iv] Mirčeski V, Komorsky-Lovrić Š, Lovrić M (2007) *Square-wave voltammetry*. In: Scholz F (ed) *Monographs in Electrochemistry*. Springer, Berlin

ML0

P

Peak potential (in \rightarrow voltammetry) — It is the potential at which the maximum current appears in \rightarrow linear scan voltammetry (LSV) and several other techniques (\rightarrow peak height). It is one of diagnostic criteria for the estimation of electrode kinetics. If the reaction is simple, fast, and \rightarrow reversible the peak potential is independent of the scan rate, or frequency, or pulse duration. The condition is that the \rightarrow electrode reaction is not complicated by the \rightarrow adsorption, the \rightarrow amalgam formation, the precipitation of solid phase, the gas evolution, or the coupled chemical reactions. In LSV and \rightarrow cyclic voltammetry (CV) of a simple, reversible, semi-infinite planar diffusion-controlled reaction $\text{Ox}_{\text{aq}} + n e^- \rightleftharpoons \text{Red}_{\text{aq}}$ the cathodic and anodic peak potentials are $E_{\text{p,c}} = E_{1/2}^{\text{r}} - 0.0285/n$ mV and $E_{\text{p,a}} = E_{1/2}^{\text{r}} + 0.0285/n$ mV, respectively, where $E_{1/2}^{\text{r}} = E_c^{\ominus'} - (RT/nF) \ln \sqrt{D_{\text{O}}/D_{\text{R}}}$ is a reversible half-wave potential, $E_c^{\ominus'}$ is the formal potential, and D_{O} and D_{R} are diffusion coefficients of the reactant and product, respectively. In LSV and CV of reversible \rightarrow surface redox reactions and the simple, reversible reactions in a thin-layer cell, which are independent of mass transfer, the peak potential is equal to the formal potential. In \rightarrow alternating current polarography and \rightarrow square-wave voltammetry (SWV) of simple, reversible reactions of dissolved reactant the peak potential is equal to the reversible half-wave potential. In \rightarrow differential pulse polarography and voltammetry of dissolved reactant, the cathodic and anodic peak potentials of reversible reaction are $E_{\text{p,c}} = E_{1/2}^{\text{r}} - \Delta E/2$ and $E_{\text{p,a}} = E_{1/2}^{\text{r}} + \Delta E/2$, respectively, where ΔE is a pulse height.

If the peak potential depends on the scan rate, or the other two parameters mentioned above, the elec-

trode reaction may be quasireversible. If, however, the relationship between the peak potential and the logarithm of these parameters is linear, the electrode reaction is considered as being totally \rightarrow irreversible and the slope of this relationship depends on the character of the reaction. If the reactant and product are dissolved, the slope is $-29.6/\alpha n$ mV for the cathodic process and $29.6/(1-\alpha)n$ mV for the anodic process. In the case of surface redox reactions these values are $-59/\alpha n$ mV and $59/(1-\alpha)n$ mV for the cathodic and anodic processes, respectively.

ML0

Peak separation (often expressed as ΔE_{peak} or ΔE_{p}) —

The difference in \rightarrow peak potentials observed in \rightarrow cyclic voltammetric or \rightarrow AC voltammetric responses in cyclic and/or higher harmonic forms for an \rightarrow analyte in bulk solution or attached to the electrode surface. In the case of corresponding anodic and cathodic peaks, a value of ΔE_{p} greater than the value predicted for reversible electron transfer may be attributed to quasireversibility of the electron transfer, to uncompensated resistance (see \rightarrow uncompensated IR drop), and/or to coupled chemical processes [i–iv]. In the case of multiple peaks associated with sequential multiple electron transfers for a single analyte or for several analytes, ΔE_{p} can also denote the difference in the peak potentials of individual electron-transfer steps.

Refs.: [i] Nicholson RS, Shain I (1964) *Anal Chem* 36:706; [ii] Nicholson RS (1965) *Anal Chem* 37:1351; [iii] Laviron EJ (1979) *Electroanal Chem* 101:19; [iv] Bond AM, O'Halloran RJ, Ruzic I, Smith DE (1976) *Anal Chem* 48:872

AMB

Peak splitting — Splitting of a single experimentally detected voltammetric peak into two or more distinguishable peaks because of a change in experimental conditions (e.g., pH, T , electrode material) or modification of the electrochemical protocol (e.g., scan rate, ac frequency and/or amplitude). This term is sometimes used as a synonym of \rightarrow peak separation.

AMB

Peak width at half-height \rightarrow half-peak-width

Peclet number — The Peclet number (Pe) is a dimensionless ratio which relates the relative importance of advection (transport of a scalar quantity in a vector field) and \rightarrow diffusion within a fluid. It is dependent on the heat capacity, density, \rightarrow velocity, characteristic length, and heat transfer coefficient and it is defined as

$$Pe = uL/\kappa$$

where L is the characteristic length, u the velocity, and κ the heat transfer coefficient and can be considered as the ratio of the heat transport by \rightarrow convection to the heat transfer by conduction within a fluid. The Peclet number may also be calculated as the product of the \rightarrow Reynolds number and the Prandtl number. The Peclet number is used extensively for the characterization of hydrodynamic systems in electrochemistry, such as the wall-jet electrode [i].

Ref.: [i] Albery WJ, Bruckenstein S (1983) *J Electroanal Chem* 144:105

AF

Pekar factor \rightarrow solvent effect

Peltier coefficient \rightarrow molar electrochemical Peltier heat

Peltier effect \rightarrow Peltier heat

Peltier heat — is the amount of heat absorbed or released when electrically charged particles (i.e., \rightarrow electrons or \rightarrow ions) are transferred from one phase to another under isothermal and reversible conditions [i]. See also \rightarrow molar electrochemical Peltier heat.

Refs.: [i] Agar JN (1963) *Thermogalvanic cells*. In: Delahay P (ed) *Advances in electrochemistry and electrochemical engineering*, vol. 3. Interscience, New York, pp 31–121; [ii] Newman J, Thomas-Alyea KE (2004) *Electrochemical systems*, 3rd edn. Wiley Interscience, Hoboken, pp 317

MBS

PEM \rightarrow polymer–electrolyte membrane

PEMFC \rightarrow polymer–electrolyte-membrane fuel cell

Peptization — A process by which an insoluble substance is dispersed as a colloidal suspension (\rightarrow colloid). This process commonly takes place when pure water is employed to remove an electrolyte from a coagulated colloid. Commonly, the precipitate is washed with a solution of an electrolyte that can be subsequently volatilized in order to minimize its contamination and prevail its peptization [i]. The diminution of the electrolyte concentration increases the \rightarrow Debye length (κ^{-1}) of the electrical \rightarrow double layer (see also \rightarrow Gouy length). Under these conditions, the screening of charge that the electrical \rightarrow double layer provides to the colloid particles is incomplete at a distance where significant short-range attractive forces (\rightarrow van der Waals) exist. Therefore, if the electrolyte concentration is low or pure water is employed to wash a coagulated colloid, the repulsive electrostatic forces between coagulated particles can prevail over the short-range attractive forces, and contribute to the colloidal state of the system [ii].

Refs.: [i] Skoog D, West D, Holler F (1996) *Fundamentals of analytical chemistry*. Saunders College Publishing, New York; [ii] Lyklema J (1991) *Fundamentals. Fundamentals of interface and colloid science*, vol. I. Academic Press, London

FG

Perchlorate — An anion consisting of an atom of chlorine in the oxidation state +7, attached to four atoms of oxygen in tetrahedral symmetry, with a symmetric distribution of charges on each atom. The Cl–O bond length is 1.5 Å. Perchlorate salts, with the exception of potassium and larger alkali metal perchlorates, are very soluble in aqueous media and in polar organic solvents. On heating, perchlorates decompose into chlorine, chlorides, and oxygen. As the reaction proceeds, the temperature increases, and the decomposition may become self-propagating. Hence, perchlorate salts may be considered as unsafe materials that can undergo thermal runaway.

Main properties of perchlorate salts:

1. Solubility and high conductivity in nonaqueous solvents and polyether solids.
2. Inertness in electrochemical reactions, being nonoxidizable at anodes and reducible at cathodes only in the presence of appropriate catalysts (e.g., Pt, Fe).
3. Vigorous oxidation strength in contact with easily combustible matter and unleashed by application of sufficiently high temperature.

Some uses of perchlorates:

1. Electrolytic solutions for \rightarrow electropolishing, \rightarrow electromachining, and electrothinning of metal parts, films, and alloys.
2. Perchloric acid is employed as an electrolyte in the anodization of metals to produce noncorroding surfaces.
3. Enhancing \rightarrow passivation of iron and steel and dissolving refractory substances such as titanium slag, copper–yttrium oxide, and metal fluorides.
4. Lithium perchlorate may be used as an \rightarrow electrolyte in primary \rightarrow lithium batteries.
5. Zinc perchlorate and magnesium perchlorate can be used as electrolytes in aqueous \rightarrow zinc and primary \rightarrow magnesium batteries. For example, zinc perchlorate is used as an electrolyte in dry cells comprising zinc anodes and manganese dioxide cathodes.

6. Perchlorate salts are used as electrolytes in \rightarrow *electropolymerization* reactions involving monomers such as aniline, benzidine, azulene, biphenyl, divinylbenzene, and indole.
7. Perchlorates may be used in electrochromic devices (\rightarrow *electrochromism*).
8. Their relatively high solubility in polymer matrices have led to the use of perchlorate salts as dopants in polymers in order to obtain antistatic behavior. As dopants in polyvinylchloride (PVC) and other chlorine-containing polymers, they improve heat stability and fire retardation characteristics.
9. Anhydrous magnesium perchlorate has long been used as an efficient drying agent, especially for industrial gases. It affords a special advantage over most desiccants because it does not lose its porous and powder morphology upon absorption of water. Hence, it can be used in drying columns for gases.
10. Due to its oxidizing nature, perchlorate salts are used in propellant mixtures, flares, pyrotechnics, and explosive formulations.

Refs.: [i] Li T, Balbuena PB (1999) *J Electrochem Soc* 146:3613; [ii] www.itrcweb.org/Documents/PERC-1.pdf; [iii] Walter R, Selsler JC, Smith M, Bogoslovo R, Piet G (2002) *J Chem Phys* 117:417; [iv] Yu L, Zhang X (2004) *J Colloid Interface Sci* 278:160; [v] Seshadri G, Bower KA, Brooks RW, Kelber JA (1995) *J Electrochem Soc* 142:744

DA, YT

Perfluorosulfonic acid (PFSA) \rightarrow polyelectrolyte

PEO \rightarrow *poly(ethylene oxide)*, and \rightarrow *polymer electrolyte*

Permittivity — Symbol: ϵ . SI units: F/m

The permittivity of a \rightarrow *dielectric* (an electronic \rightarrow *insulator*) is the ratio of an electric displacement field **D** and the electric field **E** applied to the dielectric:

$$\epsilon = \mathbf{D}/\mathbf{E}.$$

The permittivity of a dielectric is the product of the relative \rightarrow *dielectric constant* ϵ_r and the **permittivity of vacuum** ϵ_0 : $\epsilon = \epsilon_r \epsilon_0$, where $\epsilon_0 = 8.8541878176 \times 10^{-12} \text{ F m}^{-1}$. In the common case of isotropic media, **D** and **E** are parallel vectors and ϵ is a scalar, but in general anisotropic media ϵ is a tensor.

Ref.: [i] von Hippel AR (1995) *Dielectrics and waves*. Wiley, New York

ŠKL

Permittivity of seawater — Relative permittivity of \rightarrow *seawater* ($\epsilon_{r,sw}$) decreases with the chlorinity

(*Cl*), which is the chlorine equivalent of the total mass of halides that can be precipitated from 1 kg of seawater by the addition of silver nitrate. The relationship is: $\epsilon_{r,sw} = (\epsilon_{r,w} - ACl) / (1 + ACl)$, where $\epsilon_{r,w}$ is relative permittivity of \rightarrow *water*, $A = 6.00 \times 10^{-3} + 5.33 \times 10^{-6} \times T$, and T is the temperature in $^{\circ}\text{C}$. This is because of the \rightarrow *hydration* of ions dissolved in the seawater.

Ref.: [i] Ho W, Hall W (1973) *J Geophys Res* 78:6301

ŠKL

Permittivity of water \rightarrow *water* is a polar liquid with a high relative permittivity decreasing with temperature from $\epsilon_r = 87.90$, at 0°C , to 80.20 at 20°C and 55.51 at 100°C . This is because the heat accelerates the random movement of \rightarrow *dipole* molecules and disturbs their orientation in the \rightarrow *electric field*.

Ref.: [i] Meissner T, Wentz FJ (2004) *IEEE Trans Geosci Remote Sensing* 42:1836

ŠKL

Permselectivity — According to IUPAC: “A term used to define the preferential permeation of certain ionic species through \rightarrow *ion-exchange membranes*.” (See also \rightarrow *surface-modified electrodes*). Discrimination is based on the size or ion charge of the ionic species studied. Permselectivity prevents electrode surface fouling by sample matrix components, e.g., by proteins in biological fluids.

Ref.: [i] (1997) *IUPAC compendium of chemical terminology*, 2nd edn.

PK, AL

Pernigraniline \rightarrow polyaniline

Perovskites — are a very large family of compounds with the crystal structure similar to that of (Ca, Sr) TiO₃ mineral, named after the Russian mineralogist L. A. Perovski (1792–1856). This structure is often called an “inorganic chameleon” due to the diversity of chemical compositions, structural modifications, and properties. Although most members of this family are oxidic compounds, some nitrides, carbides, halides, and hydrides also have this structure.

For the ideal cubic lattice of ABO₃ perovskite, A is the larger cation surrounded by eight BO₆ octahedra. In order to estimate the general possibility of perovskite lattice formation from ionic radii, the Goldschmidt tolerance factor (t_s) can be used [i]:

$$t_s = \frac{r_A + r_O}{\sqrt{2}(r_B + r_O)}.$$

In the ideal case, $t_s = 1$. The perovskite structure forms usually in an approximate range $0.75 < t_s < 1.0$; the

deviations from unity lead to lattice distortions. The valence of A and B site cations varies usually in the ranges I–III and I–VI, respectively. The fragments of perovskite structure, such as BO_6 octahedra sheets, may also be involved in other structural types; important examples of such perovskite-related compounds include the Aurivillius series $[\text{Bi}_2\text{O}_2](\text{A}'_{n-1}\text{B}_n\text{O}_{3n+1})$ (see also \rightarrow BIMEVOX) and the Ruddlesden–Popper compounds with general formula $\text{A}_2(\text{A}'_{n-1}\text{B}_n\text{O}_{3n+1})$.

The key types of point defects in the perovskite lattices are the oxygen and A-site cation \rightarrow vacancies (see also \rightarrow defects in solids). The vacancy formation in the B sublattice is only significant for oxygen-excess perovskites, where this process is accompanied with creation of the A-site vacancies or various intergrowth lattices are formed [i, ii]. Respectively, the main ionic \rightarrow charge carriers are either oxygen anions for the oxygen-deficient lattices, or \rightarrow protons when water intercalation into oxygen vacancies is thermodynamically favorable. A fast cation \rightarrow diffusion is observed for perovskite phases where the deficient A sublattice contains relatively small cations such as Li^+ . The electronic transport is usually governed by the B–O–B bonds, but may also be contributed by variable-valence A site cations [iii]. In many cases, optimization of ionic and electronic transport is possible by \rightarrow doping, since the perovskite structure may tolerate extensive cation substitutions.

Selected groups of perovskite-type oxide materials, important for electrochemical applications, include:

- Oxygen-ion conducting $(\text{Ln},\text{A})(\text{M},\text{M}')\text{O}_{3-\delta}$ (Ln is a rare-earth cation; A = Sr, Ca, Ba; M = Ga, Al, In; M' = Mg, Ni, Co, Fe). One representative example relates to \rightarrow solid electrolytes $(\text{La},\text{Sr})(\text{Ga},\text{Mg})\text{O}_{3-\delta}$ (LSGM), with the ionic conductivity level comparable to that of doped \rightarrow cerium dioxide.
- Lithium-conducting $(\text{Ln},\text{Li})_{1-x}\text{MO}_3$ (M = Ti, V, Nb).
- Electronically-conducting $(\text{Ln},\text{A})(\text{M},\text{M}')\text{O}_{3-\delta}$ (M = Cr, Mn), used for \rightarrow cathodes and interconnects of \rightarrow solid oxide fuel cells (SOFCs).
- Mixed-conducting $(\text{A},\text{Ln})\text{MO}_{3-\delta}$ (M = Fe, Co), promising as cathodes of intermediate-temperature SOFCs, oxygen-separation membranes, and electrocatalysts for high- and low-temperature processes involving oxygen.
- Proton-conducting $\text{A}(\text{M},\text{M}')\text{O}_{3-\delta}$ (M = Ce, Zr, Ta, Nb; M' = Y, Yb, etc.).

- Semiconducting ATiO_3 and their derivatives, used also for \rightarrow sensors and photocatalysis.
- Derivatives of $\text{LaNiO}_{3-\delta}$ with a high electrocatalytic activity for oxygen evolution and peroxide decomposition.

Refs.: [i] Pena MA, Fierro JLG (2001) *Chem Rev* 101:1981; [ii] Islam MS (2002) *Solid State Ionics* 154–155:75; [iii] Goodenough JB, Zhou J-S (2001) *Transport properties*. In: Goodenough JB (ed) *Localized to itinerant electronic transition in perovskite oxides*. Springer, Berlin; [iv] Iwahara H, Asakura Y, Katahira K, Tanaka M (2004) *Solid State Ionics* 168:299; [v] Bouwmeester HJM, Burggraaf AJ (1996) *Dense ceramic membranes for oxygen separation*. In: Burggraaf AJ, Cot L (eds) *Fundamentals of inorganic membrane science and technology*. Elsevier, Amsterdam, pp 435–528; [vi] Kharton VV, Marques FMB, Atkinson A (2004) *Solid State Ionics* 174:135

VK

Peroxydisulfate — ($\text{S}_2\text{O}_8^{2-}$, the anion of persulfuric acid) is one of the famous model reactants in electrochemistry. The studies of its reduction on mercury and mercury-like metals [i–iii] contributed to the development of phenomenological theory of electrode \rightarrow kinetics. Total reduction to sulfate requires two electrons and is limited by the first step, i.e., the O–O bond rupture and formation of sulfate and sulfate radical. DC polarography in diluted solutions [i] allowed to observe the decrease of the peroxydisulfate reduction current with increasing overvoltage in the region of the limiting diffusion current, followed by a subsequent recovery of current up to the limiting value. This typical current pit was later found for the reduction of various anionic and neutral species, as well as for oxidation of some cations [ii]. Such a behavior was [iii] explained in the framework of \rightarrow Frumkin's slow discharge theory by the decrease of the interfacial reactant concentration (induced by the change of sign of the electrode charge at the \rightarrow point of zero charge), in combination with the decrease of activation energy with overvoltage. Quantitative agreement with \rightarrow Frumkin's slow discharge theory was found for a wide range of solution compositions, by taking into account ion pair formation in the media of low permittivity. For long it remained a problem unsolved by this theory to interpret the zero activation energy at the potential of the current minimum. This can now be explained [iv] in terms of an activationless electron transfer (\rightarrow activationless process) (the region of minimum corresponds to an overvoltage far above 2 V). With the use of peroxydisulfate as a model, the effects of potential(charge)-dependent reaction volume and local electrostatic interactions (interfacial ion pairing) are

treated on the basis of quantum chemical modeling of the reaction layer [iv]. The reduction of peroxydisulfate at catalytically active metals is assumed to follow a dissociative adsorption step [v], with possible subsequent chemical interaction with hydrogen adatoms in the case of Pt [vi]. The reduction of peroxydisulfate is completely irreversible. The anodic electrosynthesis of peroxydisulfate on platinum electrodes from concentrated sulfuric acid takes place at high anodic potentials [vii], resulting in important industrial processes [viii]. Peroxydisulfate is widely applied as a strong oxidizer and analytical reagent. In aqueous solutions peroxydisulfate undergoes slow pH-dependent hydrolysis with oxygen evolution.

Refs.: [i] Kryukova TA (1949) *Dokl Akad Nauk SSSR* 65:517; [ii] Delahay P (1965) *Double layer and electrode kinetics*. Interscience, New York, chap IX; [iii] Frumkin AN, Florianovich GM (1951) *Dokl Akad Nauk SSSR* 80:907; [iv] Nazmutdinov RR, Glukhov DV, Petrii OA, Tsirlina GA, Botukhova GN (2003) *J Electroanal Chem* 552:26; [v] Samec Z, Krischer K, Doblhofer K (2001) *J Electroanal Chem* 499:129; [vi] Samec Z, Doblhofer K (1994) *J Electroanal Chem* 367:141; [vii] Balej J (1984) *Electrochim Acta* 29:1239; [viii] Pletcher D, Walsh FC (1993) *Industrial electrochemistry*, 3rd edn. Blackie Academic Professional, London

OP, GT

Peters equation — Obsolete term for the → *Nernst equation* in the special case that the oxidized and reduced forms of a redox pair are both dissolved in a solution and a reversible potential is established at an inert metal electrode. Initially Nernst derived his equation for the system metal/metal ions, and it was Peters in the laboratory of → *Ostwald, F.W.* who published the equation for the above described case [i]. The equation is also sometimes referred to as Peters–Nernst equation [ii].

Refs.: [i] Peters R (1898) *Z physik Chem* 26:193; [ii] Stumm W, Morgan JJ (1996) *Aquatic chemistry*, 3rd edn. Wiley, New York, p 430

FS

Peters–Nernst equation → *Peters equation*

Pfeffer, Wilhelm Friedrich Philipp → *osmosis*, and → *Ostwald, Wolfgang*

Pfeffer cell → *osmosis*, and → *Ostwald, Wolfgang*

PFSA → *perfluorosulfonic acid*, → *polyelectrolyte*, and → *Nafion*

p-function — The negative logarithm to the base 10 of a number or variable x . It can be generally formulated as $\text{p}x = -\log x$ [i]. This function is commonly employed for dealing with very small numbers related to the concentration of a reagent. Thus, the functions pH and pOH are

employed to indicate the concentrations of the → *hydroxide ion* and the hydroxide anion, respectively. In the same way, the function $\text{p}K_w$ corresponds to the negative logarithm of the → *ion-product* constant of water.

Ref.: [i] Mendham J, Denney R, Barnes J, Thomas M (2000) *Vogel's quantitative chemical analysis*. Prentice Hall, New Jersey

FG

pH — The **pH value** is a measure of the hydrogen ion → *activity* of solutions. It is defined (theoretically) by the negative logarithm of the hydrogen ion activity according to → *Sørensen* and *Linderstrøm-Lang* (1924),

$$\text{pH} = -\log a_{\text{H}} = -\lg \frac{m_{\text{H}}\gamma_{\text{H}}}{m^0}$$

where a is relative activity, m molality, γ → *activity coefficient*, and m^0 standard molality (1 mol kg⁻¹). pH is unique in that it is a single ion quantity, which is immeasurable. It is, therefore, experimentally verified, with stated uncertainties, by pH(PS) values of primary standard buffer solutions (PS). The assignment of pH(PS) to the primary standard buffers is carried out in a Harned cell, which is without transference and thus defined a primary method of measurement, and involves the quasi-thermodynamic Bates–Guggenheim convention. Consequently, pH(PS), although a conventional quantity, can be incorporated into the internationally accepted SI system of measurement by considering the uncertainty of the Bates–Guggenheim convention.

For practical pH measurements, more convenient secondary standard → *buffer* solutions (SS) are recommended. Their secondary pH(SS) values are obtained by comparison with primary buffers in recommended cells with transference and have thus slightly larger uncertainties than pH(PS). pH(SS) can be traced back, again with stated uncertainties, to pH(PS) values and consequently to the definition of pH.

Finally, the measurement of pH(X) of unknown solutions, the actual subject of pH measurement, is carried out in practical cells with transference containing → *glass electrodes*. Calibration procedures for such practical cells are recommended so that the unknown pH(X) is traced back to pH(SS), pH(PS) and to the defined pH.

To summarize: pH measurement consists of a hierarchical system of three metrologically defined steps: (1) the definition of pH by primary pH(PS) values assigned to primary buffer solutions (PS) in a Harned cell defined as a primary method of measurement, (2) the assignment of pH(SS) to secondary buffer solutions (SS) by tracing them back to pH(PS), and (3) measurement of pH(X) of unknown solutions (X) by comparison with

pH(SS) in practical cells, which are calibrated according to defined recommendations. Assigned or measured practical pH values are thus linked to the definition of pH by traceable procedures, traceability being an internationally agreed upon standard. Traceability, consequently, is the metrological principle of pH measurement, so that pH 'scales', which are highly unsatisfactory metrologically and have caused an over twenty year-long controversy, are completely eliminated.

The given modern concept of pH and pH measurement was established by IUPAC in 2002 [i], a brief and more easily comprehensible version also containing the most relevant literature is given in [ii].

Refs.: [i] Buck RP, Rondinini S, Covington AK, Baucke FGK, Camoes MF, Milton MJT, Mussini T, Naumann R, Pratt KW, Spitzer P, Wilson GS (2002) *Pure Appl Chem* 74:2169; [ii] Baucke FGK (2002) *Anal Bioanal Chem* 374:772

pH buffer → *buffer*

pH meter → *electrometer amplifier*

pH-sensitive electrodes — Potentiometric pH measurements are performed on the basis of

- (i) → *glass electrodes*,
- (ii) → *ion-selective field effect transistors (ISFETs)*,
- (iii) → *metal-metal oxide electrodes*,
- (iv) → *redox electrodes* like the → *hydrogen electrode* and the → *quinhydrone electrode*.

See also → *potentiometric sensors*, → *potentiometry*, and → *potentiometric titration*.

Refs.: [i] Bach H, Baucke FGK, Krause D (2001) *Electrochemistry of glasses and glass melts, including glass electrodes*. Springer, Berlin; [ii] Galster H (1991) *pH-measurement: fundamentals, methods, applications, instrumentation*. Wiley-VCH, Weinheim

Phagocytosis — One form of → *endocytosis*. The incorporation of solid particles into a eukaryotic cell via the formation of cell → *vesicles*.

Phase — If the system is not homogeneous, then in order to describe its thermodynamic state we have to consider it as composed of a number, small or large, of homogeneous parts called phases each of which is described by specifying its content and a sufficient number

of other properties [i]. In other words a phase of a substance is a form of matter that is uniform throughout in chemical composition and physical state [ii]. The word phase comes from the Greek word for appearance. Generally, we distinguish solid, liquid, and gas phases, however, a substance may have several solid phases, as well. The conversion of one phase to another phase, which may occur at a given temperature, pressure, or electric potential etc., is called phase transition. See also → *phase transition*, and → *multiphase system*.

Refs.: [i] Guggenheim EA (1993) *Thermodynamics*, North-Holland, Amsterdam p 6; [ii] Atkins PW (1995) *Physical chemistry*, Oxford University Press, Oxford, p 184

FB

Phase transfer catalysis — Phase transfer catalysis is the phenomenon of rate enhancement of a reaction between two chemical species predominantly in different phases, by the addition of a third species (called a "phase-transfer catalyst") that extracts one of the reactants and carries it across the interface into the other phase so that the overall reaction speeds up. Phase transfer catalysts are typically heterocyclic compounds (such as crown ethers) or "onium ions" (such as tetraalkylammonium ions). They are classified as true catalysts because they are not consumed in the reaction. An example is the transfer of MnO_4^- from an aqueous to a non-aqueous solution by adding either a reagent (e.g., the crown ether 18-Crown-6) that makes the counter ions, e.g., K^+ , by complexation so lipophilic that the partition coefficient for the salt $[\text{K}^+ \text{-18-Crown-6}][\text{MnO}_4^-]$ is large enough to get the permanganate ions to the organic phase where they may serve as an oxidant in a reaction with a substrate. In many cases the transfer of ions is facilitated by providing highly lipophilic counter ions to track ions from the aqueous to the organic phases. The action of the catalyst is often described as due to ion-pair formation; however, even when no ion-pairs are formed, the → *lipophilicity* of a salt always depends on the lipophilicity of both ions (see → *ion partition*), and it can be increased when to the solution of a hydrophilic ion is added a lipophilic one. Electrochemistry contributes significantly to the study of phase transfer catalysis because it provides means to measure the ion partition coefficients (see → *ion partition*, → *interface between two immiscible electrolyte solutions*, → *droplets, electrochemistry of immobilized~*).

Refs.: [i] Dehmlow EV, Dehmlow SS (1980) *Phase transfer catalysis*. Verlag Chemie, Weinheim; [ii] Sasson Y, Neumann R (1997) *Handbook of phase transfer catalysis*. Blackie Academic & Professional, London

HK

BM

GI

P

FS

Phase transition — A \rightarrow phase transition occurs when the molar \rightarrow Gibbs energy (also called free energy) of a system is nonanalytic (non-smooth) over a small range of a thermodynamic variable, implying an abrupt change in the value of that variable. In many areas of science, the heat capacity is the variable of most interest. But in electrochemistry the molar density plays the central role. According to the Ehrenfests [i] phase transitions may be divided into two principal classes based on the type of nonanalyticity involved. The most commonly observed phase transitions (such as those involving solid/liquid/gas transformations) are classified as first-order transitions because they exhibit a discontinuity in the first derivative of the molar Gibbs energy with respect to \rightarrow chemical potential. Some less commonly observed phase transitions are classified as second-order transitions because they exhibit a discontinuity in the second derivative of the molar Gibbs energy. For example, the ferromagnetic phase transition in iron involves a discontinuity in the second derivative of the molar Gibbs energy with respect to the magnetic field. Phase transitions are widely observed in electrochemical systems because high values of molar Gibbs energy can easily be reached by changing the \rightarrow electrode potential. A notable mechanism by which first-order phase transitions are initiated is called \rightarrow nucleation. Other mechanisms include replacement (short-range diffusive reordering), and displacement (short-range nondiffusive reordering, also known as Martensitic reordering).

See also \rightarrow nucleation and growth kinetics.

Ref.: [i] Ehrenfest P, Ehrenfest T (1959) *The conceptual foundations of the statistical approach in mechanics*. Cornell University Press, Ithaca

SF

Phospholipids — Phospholipids are a class of lipids containing negatively charged phosphate groups. The commonest phospholipids are phosphoglycerides (general formula $(\text{RCOO})\text{CH}_2[(\text{R}'\text{COO})\text{CH}]\text{CH}_2\text{O}(\text{PO}_2^- \text{X}^+)$). These are biological surfactants made up of one glycerol molecule attached to two fatty acid moieties (R and R') and one phosphate group. Structurally, phosphoglycerides resemble triglycerides except that the phosphate group replaces one of the fatty acids. The alkyl chains of the fatty acids (R and R') are hydrophobic whereas the phosphate group is hydrophilic. Phosphoglycerides therefore readily self-assemble as bilayer \rightarrow micelles that can solubilize organic compounds.

See also \rightarrow liposomes.

SF

Phosphoric-acid fuel cell (PAFC) — In PAFCs the \rightarrow electrolyte consists of concentrated phosphoric acid (85–100%) retained in a silicon carbide matrix while the \rightarrow porous electrodes contain a mixture of Pt electrocatalyst (or its alloys) (\rightarrow electrocatalysis) supported on \rightarrow carbon black and a polymeric binder forming an integral structure. A porous carbon paper substrate serves as a structural support for the electrocatalyst layer and as the current collector. The operating temperature is maintained between 150 to 220 °C. At lower temperatures, phosphoric acid tends to be a poor ionic conductor and poisoning of the electrocatalyst at the anode by CO becomes severe.

The charge carrier in this type of fuel cell is the proton generated at the anode (fed with \rightarrow hydrogen or a hydrogen-rich gas mixture) that migrates through the electrolyte to combine with the oxygen, usually from air, at the cathode to form water.

The electrochemical reactions occurring in a PAFC are:

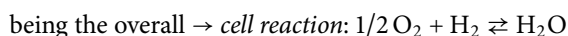
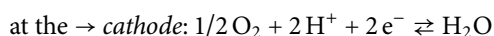
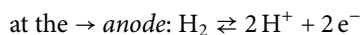

CO₂ does not affect the electrolyte or cell performance but CO is a poison when present in a concentration greater than 0.5%. If a hydrocarbon such as natural gas is used as a primary fuel, reforming according to the reaction:

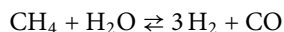

and shift of the reformat by the reaction

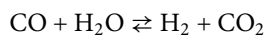

are required to generate the fuel for the cell. Also the sulfur compounds present in the fuel have to be removed prior to use in the cell to a concentration of <0.1 ppm.

The net electrical efficiency of a PAFC is typically about 40%, and a total efficiency of approximately 85% when operating in cogeneration (combined heat and power applications).

The PAFCs were the first fuel cells to be commercialized. Developed in the mid-1960s and field tested since the 1970s, they have improved significantly in stability, performance, and cost. Such characteristics have made this cell a good candidate for early stationary applications.

See also \rightarrow fuel cells.

Refs.: [i] Sammes N, Bove R, Stahl K (2004) *Curr Opin Solid State Mater Sci* 8:372; [ii] Kinoshita K (1992) *Electrochemical oxygen technology*. Wiley, New York; [iii] Appleby AJ (1996) *Energy* 21:581

JC

Photoacoustic spectroscopy → *photothermal spectroscopy*

Photoconductivity — Photoconductivity is light-sensitive → *conductivity*, due to the generation of free → *charge carriers* when photons are absorbed in a → *semiconductor*. It is called intrinsic if the photon absorption involves electron transition from occupied states of the → *valence band* to unoccupied states of the → *conduction band*. It is called extrinsic if it involves electron excitation from defect levels to the → *conduction band* or from the → *valence band* to defect levels. Photoconductivity was discovered by W. Smith in 1873 in selenium. The phenomenon was explained in 1922 by B. Gudden and R. Pohl using quantum mechanical concepts. See also → *photocurrent*.

Refs.: [i] Ng KK (2002) *Complete guide to semiconductor devices*, Wiley, New York; [ii] Meier H (1974) *Organic semiconductors*. Verlag Chemie, Weinheim; [iii] Smith W (1873) *J Soc Tel Eng* 2:31; [iv] Gudden B, Pohl R (1922) *Phys Z* 23:417

IH

Photocurrent — Contribution to the current in a → *semiconductor* due to photon incidence. For both inorganic and organic photoconductors the light intensity I_L and the photocurrent I_{ph} are related by $I_{ph} = \gamma I_L$, where γ is characteristic of the photoconducting system. In → *photovoltaic devices* photocurrent denotes the difference between the → *current* generated by the device under illumination and the current with the device in the dark, the → *dark current*. See also → *photoconductivity*.

Ref.: [i] Meier H (1974) *Organic semiconductors*. Verlag Chemie, Weinheim

IH

Photodetector — Device used to detect photons. After a long period having only thermal photodetectors, quantum photodetectors based on → *photocurrent* were developed and are used quite widely in applications such as photographic meters, flame detectors and lighting control. In the late 1950s the *p-i-n* photodiode, simply referred to as photodiode, was developed and now is one of the most common photodiodes. There are several types of photodetectors, the most adequate depending on the specific application, like photoconductors, *p-i-n* photodiodes, Schottky-barrier photodiodes, charge-coupled

image sensors, avalanche photodiodes, phototransistors, metal-semiconductor-metal photodetectors, quantum-well and quantum-dot photodetectors, and negative-electron-affinity photocathodes, which are used in photomultipliers.

Ref.: [i] Ng KK (2002) *Complete guide to semiconductor devices*. Wiley, New York

IH

Photoelectrochemistry — In principle, any process in which photon absorption is followed by some electrochemical process is termed photoelectrochemical, but the term has come to have a rather restricted usage, partly to avoid confusion with photoemission (*q.v.*). The critical requirements for normal photoelectrochemical activity is that the → *electrode* itself should be a → *semiconductor*, that the → *electrolyte* should have a concentration substantially exceeding the density of → *charge carriers* in the semiconductor and that the semiconductor should be reverse biased with respect to the solution. To follow this in detail, the differences in potential distribution at the metal–electrolyte and semiconductor–electrolyte → *interfaces* need to be understood, and these are shown in Fig. 1, which illustrates the situation for an *n*-type semiconductor under positive bias.

In this case, it can be seen that the main region over which the potential changes is not at the interface within the Helmholtz layer (→ *double layer*), as for a metal, but

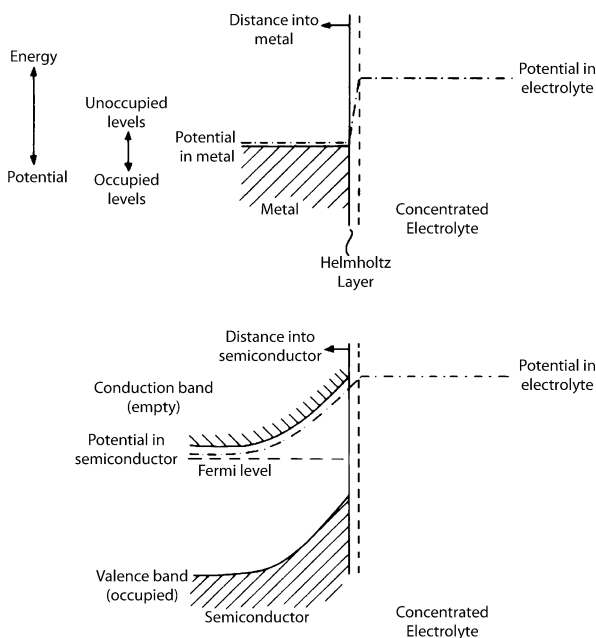

Photoelectrochemistry — Figure 1

rather within the semiconductor itself, often extending over many nm. In this region, for an n -type material, the donor sites are all ionized, creating a region of depletion. The important point is that as the bias on the semiconductor is altered, the change in potential is also entirely accommodated within this depletion, as shown in Fig. 2. The main effect of increasing the positive bias is that the depletion layer increases in thickness.

The presence of this depletion layer has profound consequences: if light of energy exceeding the bandgap is incident on the semiconductor, then the electron excited to the conduction band and the \rightarrow hole left behind in the valence band can separate under the influence of the internal \rightarrow electric field, with the electron drawn into the interior of the semiconductor and the hole driven to the surface, where, as can be seen from Fig. 3, it can be captured by an acceptor state in solution, driving an electrochemical reaction. The electron can pass round an external circuit to the counter electrode, and two types of electrochemical reaction are possible: either a second different electrochemical couple

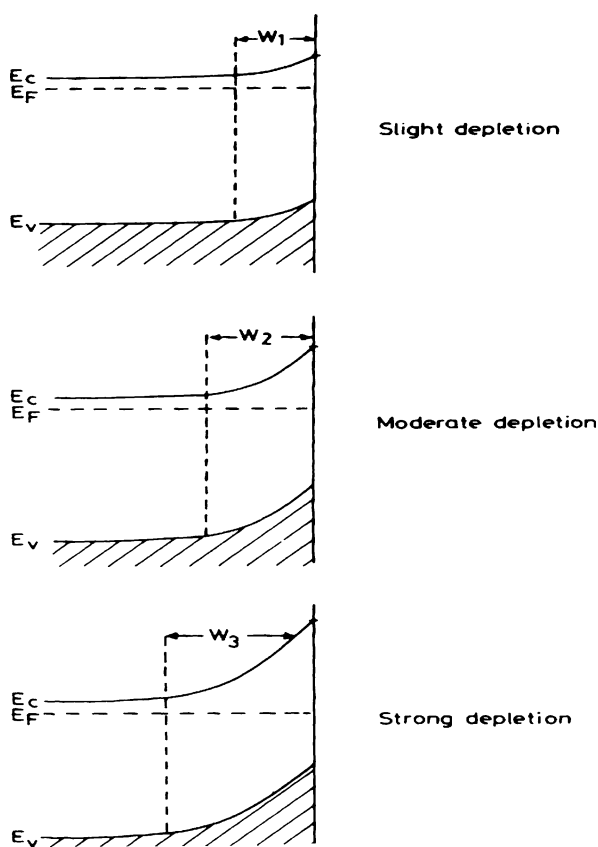

Photoelectrochemistry — Figure 2

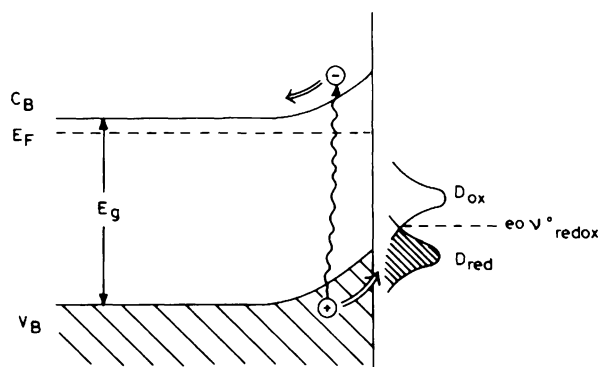

Photoelectrochemistry — Figure 3

may be involved, in which case a net chemical change is effected, and we have a true photoelectrochemical process, such as the photo-splitting of water, as shown in Fig. 4, or the same redox couple in solution recaptures the electron, the net effect being that electronic work is done in the external circuit but there is no net chemical change, as shown in Fig. 5. An important variant on the simple photoelectrochemical cell is shown in Fig. 6; in this case, the light is actually harvested not by the semiconductor itself but by a dye adsorbed on the surface of the semiconductor.

The excited state of the dye may, provided the energies match, inject an electron into the conduction band of the semiconductor, forming an oxidized species D^+ which can then accept an electron from a solution redox couple, which is, in turn, re-reduced at the counter

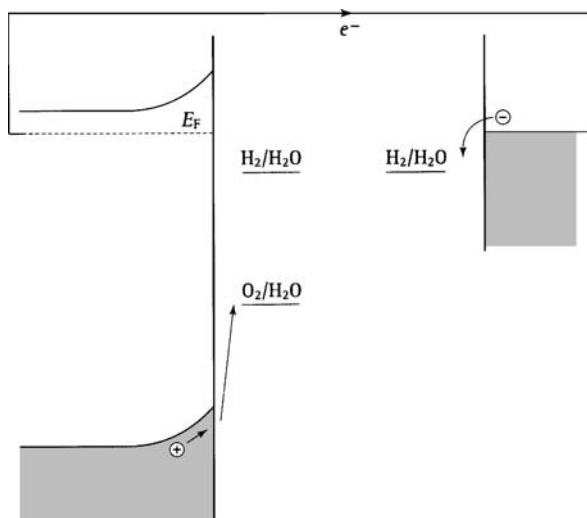

Photoelectrochemistry — Figure 4

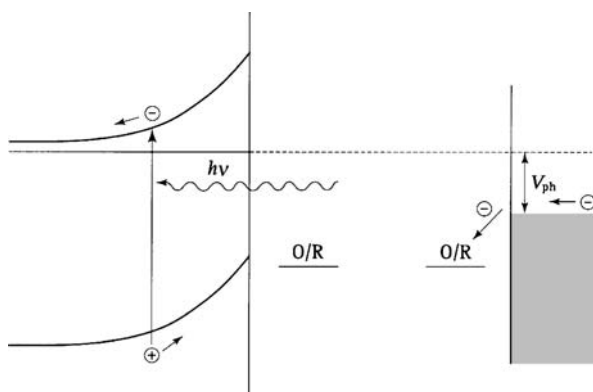

Photoelectrochemistry — Figure 5

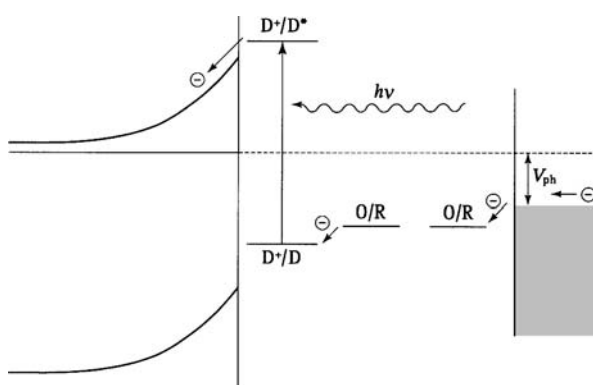

Photoelectrochemistry — Figure 6

electrode. Again there is no net chemical change, but external work is done by the electron as it passes round the circuit, converting light energy into electrical energy.

Refs.: [i] Christensen PA, Hamnett A (2000) *Electrochemical energy conversion*. In: N Hall (ed) *The new chemistry*. Cambridge University Press, Cambridge; [ii] Hamann CH, Hamnett A, Vielstich W (1998) *Electrochemistry*. Wiley-VCH, Weinheim; [iii] Bard AJ, Stratmann M, Licht S (eds) (2002) *Semiconductor electrodes and photoelectrochemistry*. Encyclopedia of electrochemistry, vol. 6. Wiley-VCH, Weinheim; [iv] Bard AJ, Memming R, Miller B (1991) *Terminology in semiconductor electrochemistry and photoelectrochemical energy conversion*, *Pure Appl Chem* 63:569–596.

AH

Photoelectron spectroscopy → *surface analytical methods*

Photoemission — Photoemission is the effect first discovered by H. R. Hertz (1857–1894) in Karlsruhe and W. Hallwachs (1859–1922) in Dresden in 1887, which is now known to be the emission of electrons from solids under illumination by electromagnetic radiation. The significance of the phenomenon historically is that it gave the first clear indication that the photons postulated by → *Planck* to explain the energy distribution of light emitted from a black body had a real physical existence. → *Einstein* was able to show that the energy of electrons emitted by the solid should obey the law: $E_{\max}^{\text{kin}} = h\nu - \Phi_0$, where Φ_0 is a constant for each material, termed the → *work function*. The basis of the modern photoemission experiment is shown in the first Figure.

The kinetic energy of the electrons is analyzed in an appropriate analyzer, and the results show the binding energy of the various electronic energy levels in the solid, as shown in the second Figure, where the resulting kinetic energy distribution of the emitted electrons reflects

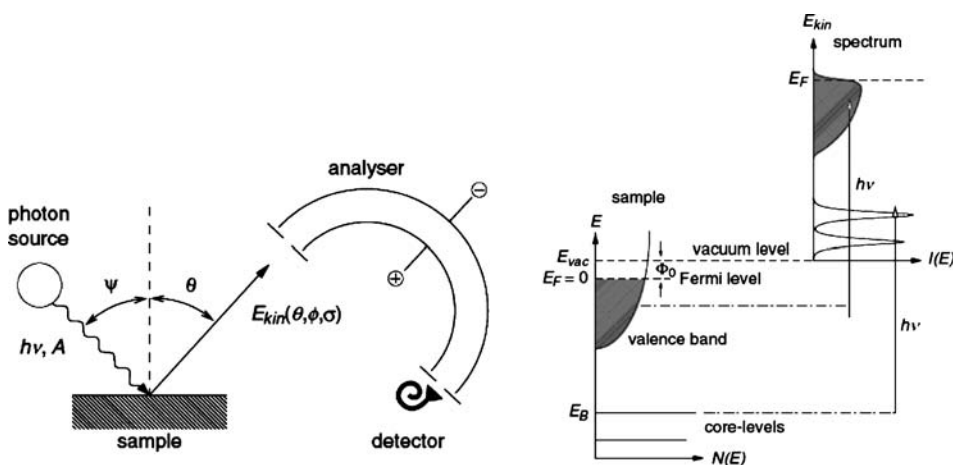

Photoemission — Figure 1

both core and valence electron energy levels, provided light of sufficient frequency is used. A major application, particularly of photoemission using X-rays, is in chemical analysis, and indeed the technique was first developed analytically for this purpose by K. Siegbahn. It can be coupled with electrochemical experiments provided that there is some means of transferring the working electrode from the cell to the spectrometer without exposing it to oxygen or any other possible reactant, and the technique has been used to analyze co-deposited metals in alloys. In a similar way, the technique can be used with UV-radiation to study details of the band structure of metals, and to follow changes in the band structure as a result of such electrochemical processes as Li insertion into TiO_2 (\rightarrow *insertion electrochemistry*). As can be seen from the next Figure, this leads to the clear development of a Ti 3d band at the \rightarrow *Fermi* edge of Li_xTiO_2 (Fig. 2).

Photoemission has also been studied directly in \rightarrow *electrolyte solutions*. As for metals in a vacuum, metal electrodes will also emit electrons on illumination with laser-UV light. In this case, the electrons are emitted into the electrolyte, with an emission intensity that depends on the $5/2$ -power of the electrode potential as $I = A(h\nu - \Phi_0 - e_0E)^{5/2}$, where E is the electrode potential measured against the point of zero charge. The subsequent fate of these electrons depends on the solvent itself. In the case of water and other polar liquids, the electrons undergo thermalization and \rightarrow *solvation* with a characteristic time not exceeding 10^{-12} sec, with the result, in water, that a source of $[\text{e}^-]_{\text{aq}}$ forms within a few nm of the electrode surface. Within a time scale of the order of 10^{-8} – 10^{-9} s these electrons will drift back

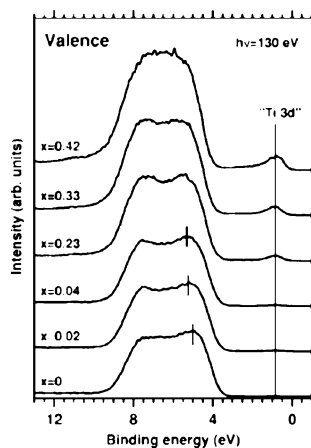

Photoemission — Figure 2

to the electrode unless further reaction with acceptors in solution can take place. The normal rate constants for this latter process are of the order 10^9 – 10^{10} $\text{M}^{-1}\text{s}^{-1}$ so concentrations of acceptor of the order 0.01 M–0.1 M are used to ensure adequate competition. The \rightarrow *radicals* formed in solution may then be detected electrochemically by time-resolved rapid potential sweep as shown above for the trifluoromethyl radical as a function of the rate at which the incident light is pulsed (Fig. 3). From these types of plot, \rightarrow *Tafel* slopes (\rightarrow *Tafel plot*) can be obtained, and working electrodes include stationary \rightarrow *mercury drop* and solid electrodes such as Au, Ag, Pb, Sn, Pt, Bi, Zn, Cd, Sb, and Cu (\rightarrow *electrode materials*). In addition, various forms of \rightarrow *carbon* including carbon nanotubes have also been studied. The solution chemistry of radical species can also be studied; where the radical contains a leaving group, dissociation is usually the rate-limiting step as in halides: $\text{RX} + [\text{e}^-]_{\text{aq}} \rightarrow \text{RX}^- \rightarrow \text{R}^+ + \text{X}^-$. Hydrogen extraction can be studied by generating highly reactive hydroxyl radicals as: $\text{N}_2\text{O} + [\text{e}^-]_{\text{aq}} + \text{H}_2\text{O} \rightarrow \text{N}_2 + \text{OH}^- + \text{OH}^\cdot$ and hydrogen atoms from reaction of aquated electrons with protons in solution.

The discussion above must be modified if the acceptor molecules adsorb onto the electrode surface. Under these circumstances, the electrons are captured by the acceptor directly rather than through an intermediary solvated electron, and such direct photoassisted electron transfer has been much studied recently with the advent of dye-sensitized solar cells and molecular electronic devices. The normal approach is to use two-photon excitation both to probe the existence of localized states at the surface and to explore their dynamics. In experiments of this nature, which have been mostly carried out on ad-

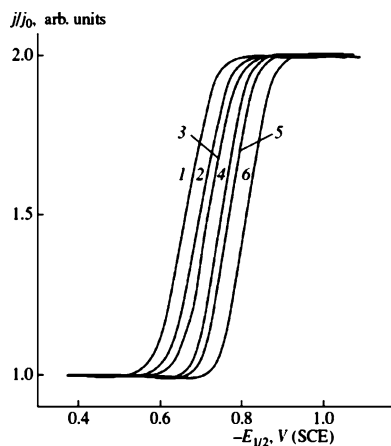

Photoemission — Figure 3

sorbed species in a photoemission apparatus to allow energy analysis of the emitted electrons, the femto-second laser used is typically a mode-locked Ti-sapphire oscillator pumped by a solid-state laser. The output (700–1000 nm) can be frequency doubled or tripled, and the resultant UV then split into two pulses for pump and probe as shown (Fig. 4).

The first pulse excites an electron in the metal, which migrates to the surface where it is either directly captured by a localized surface state arising from molecule–metal interactions or tunnels through a barrier to a molecular state more localized on the adsorbate itself. The second pulse then excites the electron to a vacuum state where it can be analyzed by energy or time-of-flight methods (Fig. 5). Interestingly, even in the absence of adsorbates, localized states can form on the surface arising through the image potential of the electron in the metal; such states are usually within 1 eV of the vacuum level and are purely electrostatic in origin. Of more interest to electrochemists are states forming through interaction of adsorbates with surfaces. Classic examples are states arising on Au(111) by interaction with alkanethiols.

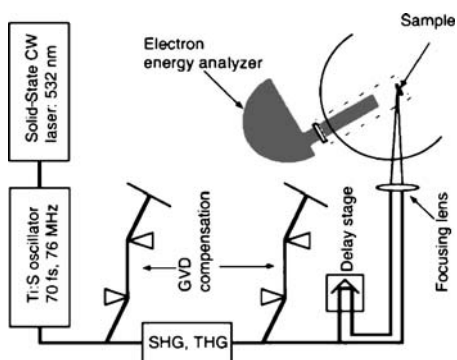

Photoemission — Figure 4

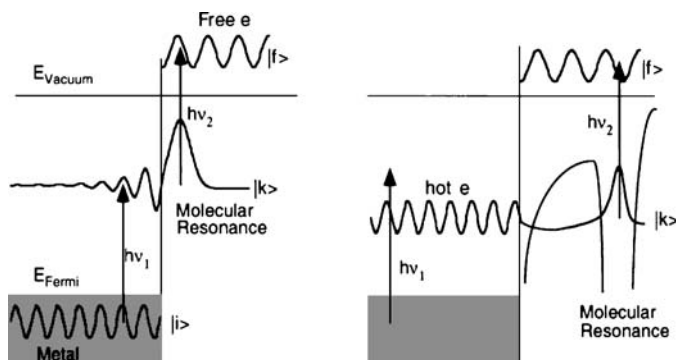

Photoemission — Figure 5

Formation of the Au–S bond in hexanethiol adsorption leads to a localized σ^* resonance which broadens and shifts when the hexanethiol molecules, initially lying flat at low coverages, realign vertically at higher coverages. Extensive studies of the model system $C_6F_6/Cu(111)$ have shown the presence of a transient anionic resonance, and similar studies are now being carried out on other systems.

Refs.: [i] Görlich P(1962) *Photoeffekte*. Geest & Portig, Leipzig; [ii] Gurevich YuYa, Pleskov YuV, Rotenberg ZA (1980) *Photoelectrochemistry*. Consultants Bureau, New York; [iii] Reinert F, Hüfner S (2005) *New J Phys* 7:97; [iv] Krivenko AG, Kotkin AS, Kurmaz VA (2005) *Russ J Electrochem* 41:122, 137; [v] Zhu XY (2002) *Ann Rev Phys Chem* 53:221; [vi] Lindstrom CD, Muntwiler M, Zhu XY (2005) *J Phys Chem B* 109:21492

AH

Photosynthesis, electrochemical aspects —

Life on Earth has been supported by the continuous flow of solar energy over billions of years. The power of this flux is extremely high: 5×10^{21} kJ per year of which 3×10^{18} kJ is converted into chemical energy by photosynthesis in plants and microorganisms. In water-oxidizing photosynthesis two membrane-integrated protein complexes photosystem II (PS II) and photosystem I (PS I) operate in series. The \rightarrow *electron transfer* starts in both photosystems vectorially across the membrane. Light energy is harvested by photosynthetic pigment systems in which the electronic structure of excited-state chlorophyll donates an electron to a primary acceptor pheophytin, the first component of an electron transport chain. The electron gains the energy of the original photon of light absorbed. In the process of electron transport, the energy is captured in two ways. The first involves the coupling of a proton pump mechanism to the sequential redox reactions in the electron transport chain, so that a pro-

ton gradient is established across the thylakoid membrane. The electrochemical energy of the proton gradient is then used to drive ATP synthesis by the ATP synthase enzymes embedded in the membrane. The second energy capture occurs when an acceptor molecule such as NADP^+ is reduced to NADPH, which in turn is used to reduce carbon dioxide in the Calvin cycle. The oxygen-evolving complex is a highly ordered structure in which a number of polypeptides interact to provide the appropriate environment for cofactors such as manganese, chloride, and calcium, as well as for electron transfer within the complex. Plastoquinone (PQ) acts as a transmembrane carrier of electrons and protons between reaction centers of two photosystems in the case of noncyclic electron transfer. Pheophytin is an intermediate acceptor in photosystem II. Water oxidation to molecular oxygen is a multielectron process that proceeds with surprisingly high quantum efficiency. Membrane-bound P680 enters an excited state upon illumination. In several picoseconds an electron is first transferred to pheophytin, then to plastoquinone Q_A , and from plastoquinone Q_A to another polypeptide-bound plastoquinone Q_B in the thylakoid membrane resulting in an oxidized pigment and a reduced acceptor. The cation radical P680^+ successively oxidizes four manganese ions, which in turn drives the production of molecular oxygen. The transfer of electrons in a 1:1:1:1 series from a manganese cluster to the electron-transport chain is accompanied by the ejection of 1:0:1:2 protons and the evolution of molecular oxygen.

Refs.: [i] Volkov AG (1989) *Bioelectrochem Bioenerg* 21:3; [ii] Volkov AG (2002) *Biocatalysis: electrochemical mechanisms of respiration and photosynthesis*. In: Volkov AG (ed) *Interfacial catalysis*. Marcel Dekker, New York

AV

Photothermal calorimetry → *photothermal spectroscopy*

Photothermal deflection spectroscopy — Photothermal deflection is a photothermal spectroscopic technique used to detect the changes in the refractive index of the fluid above an illuminated sample by the deflection of a laser beam. There are two sources from which the thermal deflection effect might appear. One of them is produced by a gradient in the refractive index after a thermal excitation where the density also varies with temperature, in the so-called mirage effect. And the other one is produced by the topographical deformation of the surface over which the laser beam is reflected. This effect is known as photothermo-elastic effect or surface photothermal deflection [i].

Ref.: [i] Terazima M, Hirota N, Braslavsky SE, Mandelis A, Bialkowski SE, Diebold GJ, Miller RJD, Fournier D, Palmer RA, Tam A (2004) *Pure Appl Chem* 76:1083

MBS

Photothermal spectroscopy — The interaction of electromagnetic radiation with matter causes an absorption, emission, and dispersion of the radiation. Except for emission and dispersion, the electromagnetic energy is absorbed and converted into heat by various nonradiative processes. Thus, the conversion of electromagnetic energy into heat raises the temperature and modifies pressure and refractive index of the media. The detection of the changes of temperature produced by the absorption of radiation at different wavelengths provides a characteristic spectrum; this technique is called photothermal spectroscopy. Photothermal techniques are methods used to detect the effect of the heating following the absorption of radiation, in such a form that several physical properties depending on temperature can be detected (e.g., pressure, refractive index, absorbance changes, thermal radiation) and other dynamic process also can be simultaneously monitored. These techniques bear their names according to the variable being sensed as a function of the temperature, for example, photoacoustic spectroscopy monitors pressure changes, photothermal calorimetry measures temperature changes and → *photothermal deflection* measures the changes in the refractive index. Photothermal techniques have several advantages with respect to other spectroscopic methods. They are highly sensitive and can be applied to materials in different phases (e.g., gas, liquids, liquid crystals, and solids) as well as different optical properties, e.g., transparent or opaque. Photothermal spectroscopy can operate in either vacuum or air and the sample may have different geometries. Experiments take place without any contact with the sample and they are considered as nondestructive techniques. Photothermal spectroscopies are widely used in physics, chemistry, biological sciences, and engineering [i].

Ref.: [i] Terazima M, Hirota N, Braslavsky SE, Mandelis A, Bialkowski SE, Diebold GJ, Miller RJD, Fournier D, Palmer RA, Tam A (2004) *Pure Appl Chem* 76:1083

MBS

Photothermo-elastic effect → *photothermal deflection spectroscopy*

Photovoltaic device — A photovoltaic device generates a → *voltage* when exposed to electromagnetic radiation. When light, X-rays, β -rays, or other radiation, whose

quantum energy exceeds a threshold of the order of the \rightarrow semiconductor band gap energy, ionizes the region in or near a potential barrier, a photovoltaic potential is generated. The photovoltaic effect was discovered by E. Becquerel (1820–1891) in 1839, at the \rightarrow interface between an \rightarrow electrode and an \rightarrow electrolyte. The most important device application of the photovoltaic effect is the solar cell for conversion of solar radiation into electrical energy.

Refs.: [i] Ng KK (2002) *Complete guide to semiconductor devices*. Wiley, New York; [ii] Becquerel E (1869) *Compt Rend* 9:561; [iii] Seeger K (1991) *Semiconductor physics – an introduction*. Springer, Berlin

IH

Phthalocyanine — Organic compound ($C_{32}H_{18}N_8$; name based on (Greek) kyanous = blue and phthalo... derived from naphthaline describing a relationship to phthalic acid):

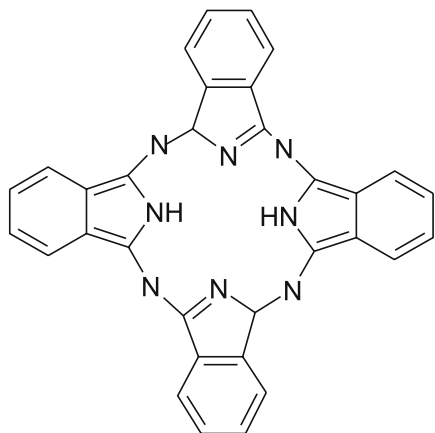

Phthalocyanine — Figure

The molecule is very stable and can be sublimed [i]. Numerous metal phthalocyanines can reversibly bind molecules like, e.g., dioxygen at the metal ion. This can result in activation of internal bonds and subsequent facilitation of chemical reaction, in this case of dioxygen \rightarrow electroreduction. Thus these molecules have attracted attention as catalysts for various reactions, in particular dioxygen reduction in, e.g., \rightarrow fuel cells [ii], in general \rightarrow electrocatalysis [iii] and in \rightarrow sensors [iv]. Their strong coloration, which can be modified electrochemically by reduction/oxidation, suggests use in \rightarrow electrochromic devices [v].

Refs.: [i] Beilstein EIII/IV 26, 4255; [ii] Jahnke H, Schönborn M, Zimmermann G (1976) *Top Curr Chem* 61:133; [iii] Vasudevan P, Santosh, Mann N, Tyagi S (1990), *Transition Met Chem* 15:81; [iii] Zagal JH (1992) *Coord Chem Rev* 119:89; [iv] Lever ABP (1999) *J Porphyrins Phthalocya-*

nines 3:488; [v] Somani PR, Radhakrishnan S (2003) *Mater Chem Phys* 77:117

RH

π -complex — An \rightarrow adduct formed by electron-pair donation from or to a π -orbital. It is recommended to use the term π -adduct instead [i].

Ref.: [i] Muller P (1994) *Pure Appl Chem* 66:1077

FG

pl-meter \rightarrow electrometer amplifier

Piezoelectric filter \rightarrow analog filter

Piezoelectricity (piezoelectric effect) — is the ability of certain crystals to generate a \rightarrow voltage in response to deformation (torsion, press, squeeze, pull) or other mechanical stress. The effect was discovered in 1880 by Pierre Curie (1859–1906) and Jacques Curie (1855–1941). When piezoelectric crystals are stressed in a particular direction, the formerly symmetrically distributed positive and negative lattice ions/electrical charges are shifted, which results in a charge \rightarrow polarization and electric \rightarrow dipole moment. The occurring charge separation on the surface reflects the amount of pressure applied to it, and manifests itself as apparent macroscopic surface charge of the overall neutral crystal (see also \rightarrow electroneutrality condition). Exemplarily, the voltage, generated by the piezoelectrically induced charge asymmetry, can exceed 12,500 V for a quartz cube of 1 cm edge length, with 2 kN force applied upon it. Around twenty natural crystal classes show direct piezoelectricity, among which are quartz, tourmaline, topaz, quartz analogue crystals like berlinite, and gallium orthophosphate. Moreover, several ceramic materials, or so-called piezoceramics, often with perovskite or tungsten–bronze structures, as titanates or niobates, exhibit a piezoelectric effect sufficient for technical utilization, like in sensors, piezo-lighters, and others. Polymer materials including polyvinylidene fluoride or rubber exhibit piezoelectricity, also materials like wool, silk, and wood fiber, and, to some extent, hair, and bone. The piezo-effect is reversible; via the application of an electrical field or externally applied (AC) voltage, mechanical oscillations of the piezoelectric crystals are generated, which leads to a certain nanometer-sized dislocation/deformation or change of shape. Since the beginning of the 20th century, with the first practical application for a piezoelectric device being an ultrasonic submarine detector (sonar) in 1917, both, direct and reverse piezoelectricity find numerous applications in many fields of

technology, science, and industry, e.g., electronic high-frequency and high-voltage sources ('high-voltage differentials'), voltage transformer (AC voltage multiplier), piezoceramic radios and TV filters, for sound generation and detection (loudspeakers, microphones), in ink-jet printer heads, for ultrasonic generation and ultrasonic time-domain reflectometers. Their ability to move large mass over microscopic dimensions with high precision is exploited in piezoelectric actuators and motors, as for ultrafine focusing and alignment of optical assemblies (laser mirrors) or in \rightarrow AFM and \rightarrow STM arrangements, or the auto-focus in cameras. As a related application, the acousto-optic modulator can fine-tune a laser frequency by vibrating a mirror to give the reflected light a Doppler shift. They are used as frequency standards in (ultraprecise) quartz clocks, and in piezoelectric microbalances (see \rightarrow quartz crystal microbalance, \rightarrow electrochemical quartz crystal microbalance).

Refs.: [i] Vives AA (2004) *Piezoelectric transducers and applications*. Springer, Berlin; [ii] Lu C, Czanderna AW (eds) (1984) *Applications of piezoelectric quartz crystal microbalances (Methods and phenomena, their applications in science and technology)*. Elsevier, New York

MHer

Pile \rightarrow electrochemical pile

Pile electroscop (electrometer) \rightarrow Fechner electroscop

Pincus cell (also called silver chloride cell) — This cell was developed almost at the same time by Pincus, Warren de la Rue, and Müller. An amalgamated zinc rod and a silver beaker filled with silver chloride were placed in a NaCl solution.

Ref.: [i] Pfaunder L (1888–1890) *Müller-Pouillet's Lehrbuch der Physik und Meteorologie*, 9th edn, vol. 3. Vieweg, Braunschweig, p 385

FS

Pitting corrosion — A localized type of \rightarrow corrosion penetrating a metal perpendicularly to its surface rather than spreading laterally. Metals undergoing \rightarrow passivation (aluminum alloys, stainless steel, nickel alloys) are prone to pitting corrosion because uniform corrosion processes are largely suppressed by passive layers on such materials. The pitting corrosion occurs typically in the presence of halide ions but the relative rates of degradation (e.g., in chlorides or fluorides) depend on the composition and surface morphology of the investigated metal material.

The mechanism of pitting corrosion involves two steps: pit initiation and pit growth. Mechanism of pit

initiation is not well understood yet. Most mechanisms emphasize the necessity of damage of passive layer, either mechanical or chemical, in the initial stage. Such defects as grain boundaries, other metal intrusions, or steps on metal surfaces make the passive layer thinner in those places, and they can become starting points for pitting corrosion of some materials. Halogen anions may also replace hydroxyl ions in the passive layer or diffuse through it to the metal surface. Solubility of metal halides formed there usually favors the pit growth. In view of vacancy theory (\rightarrow vacancies), pitting corrosion can be understood in terms of \rightarrow diffusion of metal cations through the passive layer from the metal surface to the solution and the movement of "cation vacancies" in the opposite direction. The presence of sufficient amounts of such vacancies on the metal surface would cause the rupture of the passive layer. The theory often allows estimation of the pit initiation rate. In the above discussion, it is assumed that the passive layer is a static system but, in reality, it seems to be a dynamic one that breaks and repairs itself. Pits are initiated within passive layers of certain thicknesses and in the sufficiently concentrated halide solutions. The passive layer can repair itself later and, under certain conditions, limit the further pit growth.

The growth of pits is an autocatalytic reaction involving oxidation of metals within the pit that becomes a local source of cations capable of the local attraction of anions (halides) to form hydrochloric acid in the presence of water:



This anodic reaction results in the local increase of the halide (e.g., Cl^-) concentration and in the decrease of pH inside the pit. On the other hand, the pit growth is accompanied by the cathodic protective reaction (occurring outside the growing pit), namely by the reduction of oxygen to hydroxyl ions:

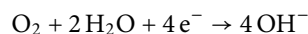

that tends to block somewhat the lateral expansion of corrosion. The relative rates of the reactions often depend on the metal surface areas.

Refs.: [i] Frankel GS (1998) *J Electrochem Soc* 145:2186; [ii] Szklarska-Smialowska Z (1986) *Pitting corrosion of metals*. National Association of Corrosion Engineers; [iii] Punckt C, Bölscher M, Rotermund HH, Mikhailov AS, Organ L, Budiansky N, Scully JR, Hudson JL (2004) *Science* 305:1133

PK, AL

Planck, Max Karl Ernst Ludwig



(© The Nobel Foundation)

(Apr. 23, 1858, Kiel, Germany – Oct. 4, 1947, Göttingen, Germany) Ph.D. Berlin 1879, 1885 Professor in Kiel, 1889–1927 Professor in Berlin. Since 1894 member and since 1912 permanent secretary of the Prussian Academy of Sciences. From 1930–37 and 1945–46 Planck was President of the ‘Kaiser-Wilhelm-Gesellschaft zur Förderung der Wissenschaften e.V.’, i.e., the later ‘Max-Planck-Gesellschaft zur Förderung der Wissenschaften e.V.’ Planck made fundamental contributions to → *thermodynamics*, the theory of dilute → *solutions*, dissociation, and equilibria. In 1900 he found an equation describing the spectral distribution of energy of black body radiation in which he had to introduce a ‘Wirkungsquantum’ later referred to as → *Planck constant*. This was the start of the quantum area in physics and chemistry. Planck was awarded the Nobel Prize for 1918, which he received in 1919. See also → *Nernst–Planck equation*.

Refs.: [i] Frank J (1948) *Science* 107:534; [ii] Meitner L (1958) *Naturwiss* 45:406

FS

Planck constant — To describe the spectral distribution of energy of black body radiation → *Planck* made the ad hoc assumption that the radiant energy could exist only in discrete quanta which were proportional to the frequency: $E = h\nu$; with $h = 6.6260693(11) \times 10^{-34}$ Js. Before 2003 the accepted value was $6.6260755(40) \times 10^{-34}$ Js = $4.1356692(12) \times 10^{-15}$ eV s. The quantity h later was referred to as Planck’s constant.

Refs.: [i] Cardarelli F (1997) *Scientific unit conversion. A practical guide to metrication*. Springer, London; [ii] The National Institute of Standards and Technology (NIST) *Reference on constants, units and uncertainties* (2003), <http://physics.nist.gov/cuu/constants>; [iii] Mills I (2004) *Chemistry International (IUPAC)* 26 (3):17; [iv] Mills I, Cvitas T, Homann K, Kallay N, Kuchitsu K (eds) (1993) *IUPAC quantities, units and symbols in physical chemistry*. Blackwell Scientific Publications, Oxford, p 58, 89

FS

Planck equation → *diffusion potential*

Plant electrophysiology — All processes of living organisms examined with suitable and sufficiently sensitive measuring techniques generate → *electric fields* and the conduction of electrochemical excitation must be regarded as one of the most universal properties of living organisms. It arose in connection with a need for the transmission of a signal about an external influence from one part of a biological system to another. The study of the nature of regulatory relations of the plant organism with the environment is a basic bioelectrochemical problem. The inducement of nonexcitability after excitation and the summation of subthreshold irritations were developed in the plant and animal kingdoms in protoplasmatic structures prior to morphological differentiation of nervous tissues. These protoplasmatic structures merged into the organs of a nervous system and adjusted the interfacing of the organism with the environment. → *Action potentials* in plants have been studied in detail in the giant cells of *Chara* and *Nitella*. These plants possess many of the properties associated with action potentials of animal cells such as the all-or-nothing law, threshold potential, and a refractory period. The plasma → *membrane* allows for cells, tissues, and organs to transmit electrochemical signals over short and long distances. Excitation waves or action potentials in higher plants are tools for intercellular and intracellular communication in the presence of environmental changes. Plants respond to irritants at the site of the applied stimulus, but excitation can be dispersed throughout the entire plant. Waves of excitation travel from the top of the stem to the root and from the root to the top of the stem, but not at identical rates. The speed of propagation depends on the chemical treatment, intensity of the irritation, mechanical wounding, previous excitations, or temperature. Physical factors such as electromagnetic or gravitational fields, mechanical wounding, and temperature effects also elicit electrical impulses. Plants respond quickly to changes in luminous intensity, osmotic pressure, and temperature. Action potentials activate the membrane enzymatic systems. These systems realize biochemical reactions, accelerate the production of ethylene, increase the concentration of proteinase inhibitors, and modify the rate of production of polysomes and proteins. Many physiological responses in higher plants occur within seconds of the application of a stimulus: gravitropic responses, thigmotropic responses in *Mimosa pudica* and *Dionaea muscipula*, growth responses to salinity, and stomatal closure following treatment of *Salix* roots with abscisic acid. The speed of propagation of bioelectrical signals ranges from 0.05 cm/s to 40 m/s and it adequately sustains swift

long-distance communication. This also allows for the rapid response feature to be observed in plants. A potential pathway for transmission of this electrical signal might be the phloem sieve-tube system, which represents a continuum of plasma membranes, the xylem, and plasmodesmata. Phloem consists of two types of conducting cells: the characteristic type known as sieve-tube elements and another type called companion cells. Electrolytic species such as K^+ , Ca^{2+} , H^+ , and Cl^- are actively involved in the establishment and modulation of electrical potentials. Specificity of communication can be accomplished through modulation of the amplitude, the duration, the direction of the change in polarity, and the rate of propagation of the electrical potential signal. Many electrophysiological parameters are highly variable within higher plants, including the excitability state, the excitability threshold, the velocity of impulse movement, and the length of the refractory period.

Ref.: [i] Volkov AG (ed) (2006) *Plant electrophysiology*. Springer, New York

P

Planté, Gaston



(April 22, 1834, Orthy, France – May 21, 1889, Paris, France) French physicist, professor in Paris from 1860, constructed the first practical → *secondary cell* (→ *accumulator*), the → *lead-acid accumulator* by improving the invention of → *Sinsheden*.

Refs.: [i] Magnusson M (ed) (1990) *Chambers biographical dictionary*. W&R Chambers, Edinburgh; [ii] Crystal D (ed) (1998) *The Cambridge biographical encyclopedia*. Cambridge University Press, Cambridge

RH

Plasma electrochemistry — Gas plasmas possess mixed electronic and ionic conductivities. This allows their use as ion → *conductors* in electrochemical cells, i.e., interfaced with electronic conductors [i, ii], and, when they are in intimate contact with solid or liquid → *electrolytes*, they can be also used as the electronically conducting

part of an → *electrode* [iii]. Plasma-electrochemical deposition at a liquid electrolyte interface goes back to the late 19th century [iv], and was revived recently using → *ionic liquids* [v]. Plasmas are also involved in glow discharge electrolysis [vi]. Due to the elaborate experimental set-up, and due to the mixed conductivity of plasmas, progress in plasma electrochemistry started rather late.

Refs.: [i] Hadzifejzovic E, Sanchez Galiani JA, Caruana DJ (2006) *Phys Chem Chem Phys* 8:2797; [ii] Hadzifejzovic E, Stankovic J, Firth S, McMillan PE, Caruana DJ (2007) *Phys Chem Chem Phys* 9:5335; [iii] Vennekamp M, Janek J (2003) *J Electrochem Soc* 150:C723; [iv] Gubkin J (1887) *Ann Phys Chem (N F)* 32:114; [v] Poellet M, Meiss SA, Rohnke M, Kienle L, El Abedin SZ, Endres F, Janek J (2007) *Proceedings of the XXVIIIth International Conference on Phenomena in Ionized Gases, Prague, Czech Republic*. [vi] Hickling A (1971) *Electrochemical processes in glow discharge at the gas-solution interface*. In: Bockris JO'M, Conway BE (eds) *Modern Aspects of Electrochemistry*, No. 6. 329–73

FS

AV Plasmon resonance (simultaneous application in voltammetry) — Surface plasmon resonance (SPR) is a surface-sensitive optical technique, typically applied to the characterization of biological → *membranes*, → *proteins*, and → *Langmuir-Blodgett films*, or for transducers of optical sensing systems and bioanalytical → *sensors*. The technique measures the change in the refractive index, due to changes at a metal-dielectric interface, e.g., due to binding interactions. The basic principle is the surface plasmon resonance effect, based on the interaction between electromagnetic waves of incident light and free electrons in a conducting surface layer. Electron charges, located at a metal|dielectric interface, can be caused to undergo coherent fluctuations known as surface plasma oscillations or surface plasmons. The incident light is totally reflected above a certain critical angle at the interface of two → *dielectric* media, and it generates an evanescent field with its maximum intensity at the surface. In case of certain metal supports (see below), the field can be enhanced, and the surface plasmons, i.e., free metal surface electrons, resonate with it. Depending on wavelength, angle of incidence, and refractive index at the phase boundary, resonance conditions are produced if electromagnetic radiation, leaving the interface, excites the plasmons to coupled vibrations. That leads to an attenuation of the reflected beam at a certain so-called resonance angle (see Figure).

The measuring system consists of a thin metal film, generally of gold, silver, and occasionally copper or aluminum, produced by vacuum deposition onto a glass

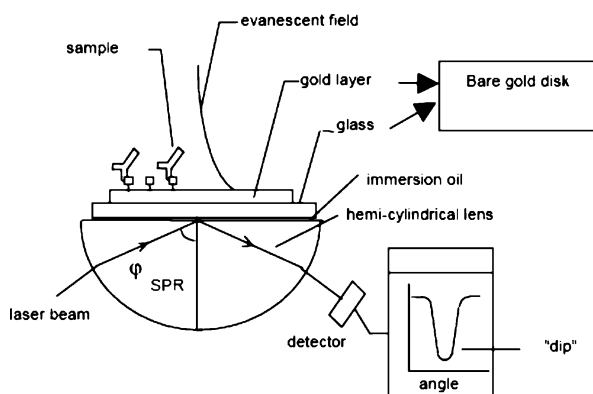

Plasmon resonance — Figure

prism (or half cylinder). The SP excitation is usually accomplished by an attenuated total reflection coupler, where the base of a prism is coated with a ca. 50 nm thin metal film, using incident monochromatic p-polarized (light polarized parallel to the plane of incidence) light to be reflected at this interface. The plasmon resonance is observed as a sharp minimum in the intensity of the reflected light, and it can be detected by scanning the incident angle. Small changes at the metal|dielectric interface, as, e.g., the build-up of a thin layer, are thus measured as a corresponding shift in the resonance angle Θ . Alternatively, there are SPR setups using convergent light beams at a preset angle, corresponding to a number of incidence and reflecting angles, detected with an array of photodiodes. The latter setup comprises a lower resolution.

SPR transducers were first described in 1983, and they have been used in \rightarrow immunoassays, or \rightarrow sensors for gases and liquids. Examples of biomolecular studies include the interactions of: peptide–antibody, protein–antibody, protein–DNA, protein–virus, protein–cell, or DNA–DNA. For the immunosensing, i.e., antibody–antigen interaction, the metal layer is coated with appropriate covalently immobilized or matrix-embedded antibodies. A solution of the target molecule flows across the metal film ‘chip’, and the exposure to a specific antigen will result in a resonance angle shift, i.e., a thickness change of 0.1 nm results in a 0.01° change in the resonance angle. As chemical sensor, the metal surface must be coated with a thick dielectric layer of a reactive chemical, and the chemical reaction corresponds again to a certain shift in Θ . Self-assembled receptor layers or intermediate binding of another protein have successfully been applied for peptides, usually on Au electrodes. The detection principle limits the overall molecular mass

of the analytes below approximately 5 kDa. Also, particles larger than 400 nm cannot be measured totally.

Through the combination of SPR with a \rightarrow potentiostat, SPR can be measured in-situ during an electrochemical experiment (electrochemical surface plasmon resonance, ESPR). Respective setups are nowadays commercially available. Voltammetric methods, coupled to SPR, are advantageously utilized for investigations of \rightarrow conducting polymers, thin film formation under influence of electric fields or potential variation, as well as \rightarrow electropolymerization, or for development of \rightarrow biosensors and \rightarrow modified electrodes. Further in-situ techniques, successfully used with SPR, include electrochemical \rightarrow impedance measurements and \rightarrow electrochemical quartz crystal microbalance.

Refs.: [i] Liedberg B, Nylander C, Lundström I (1983) *Sens Actuators* 4:299; [ii] Raether H (1988) *Surface plasmons on smooth and rough surfaces and on gratings*. Springer, Berlin; [iii] Homola J, Yee SS, Gauglitz G (1999) *Sens Actuators B54:3*; [iv] Homola J (2006) *Surface plasmon resonance*. Springer, Berlin

MHer

Platinized platinum \rightarrow electrode materials

Platinum \rightarrow electrode materials

Platinum black \rightarrow electrode materials

Platinum–ruthenium \rightarrow electrode materials

Plush cell — This was a variant of the \rightarrow Daniell cell. See also \rightarrow zinc, \rightarrow Zn^{2+}/Zn electrodes, \rightarrow $Zn^{2+}/Zn(Hg)$ electrodes, \rightarrow zinc–air batteries (cell), and \rightarrow Leclanché cell.

Ref.: [i] Hauck WP (1883) *Die Galvanischen Batterien, Accumulatoren und Thermosäulen*, 2nd edn. Hartleben's Verlag, Wien

FS

Pockels, Agnes Luise Wilhelmine



(Courtesy of TU Braunschweig)

(Feb. 14, 1862, Venice, Italy – Nov. 21, 1935, Braunschweig (Brunswick) [i], Germany) Agnes Pockels went

to school in Braunschweig, but she could not make the 'Abitur', the German school leaving examination for joining a university, as that was not allowed for girls at her time. She was an autodidact in mathematics and physics and performed experiments at home in her kitchen. Her brother Friedrich Pockels studied physics, became professor and was able to support her studies with literature. Friedrich Pockels discovered the effect of an electrostatic field on the optical properties of crystals (Pockels effect). In 1862, Agnes Pockels developed a special trough in her kitchen (now called Pockels trough), and she could compress surface layers and measure the force with a balance construction. That development resulted from a careful observation of \rightarrow *interfacial (surface) tension* changes when she washed dishes. In 1891, Agnes Pockels communicated her experiments and results to Lord Rayleigh, who suggested a publication in *Nature* [ii] (see also [iii-viii]). \rightarrow *Langmuir* sophisticated and improved the experimental approach that is now known as the Langmuir- or Langmuir-Pockels balance (trough). In 1932 she was honored with a honorary doctorate of the Technische Hochschule Braunschweig.

See also \rightarrow *capillarity*.

Refs.: [i] (a) Derrick ME (1982) *J Chem Educ* 59:1030; (b) Beisswanger G (1991) *Chemie unserer Zeit* 25:97; [ii] Pockels A (1891) *Nature* 43:437; [iii] Pockels A (1892) *Nature* 46:418; [iv] Pockels A (1893) *Nature* 48:152; [v] Pockels A (1894) *Nature* 50:223; [vi] Pockels A (1899) *Ann Phys Chem* 303:668; [vii] Pockels A (1917) *Naturwiss* 9:137, 149; [viii] Pockels A (1918) *Naturwiss* 6:118; [ix] Pockels A (1914) *Phys Z* 15:39; [x] Pockels A (1916) *Phys Z* 17:142; [xi] Pockels A (1916) *Phys Z* 17:441; [xii] Pockels A (1926) *Science* 64:304

Pockels trough \rightarrow *Pockels*

Poggendorff, Johann Christian



(Dec. 29, 1796, Hamburg, Germany – Jan. 24, 1877, Berlin, Germany) 1812–20 working in an apothecary,

then university studies in Berlin, and since 1834 extraordinary professor of physics in Berlin. In 1820 he developed independent of \rightarrow *Schweigger* the first electromagnetic measuring instrument, the so-called multiplier. Multiplier was the name for a measuring instrument where a number of metal coils multiplied the effect of a current on a magnetic needle, and which therefore was suitable for measuring very small currents. Poggendorff also developed the mirror galvanometer to be able to read very small inclinations of a magnet in the vicinity of metal coils through which a current passes [i]. In 1841 he developed what is now called the \rightarrow *Poggendorff compensation circuit*. Since 1824 he edited the "Annalen der Physik", all in all 160 volumes. Because of this heavy work load he always refused to accept a chair in physics.

Ref.: [i] Pfaundler L (1888-1890) *Müller-Pouillet's Lehrbuch der Physik und Meteorologie*, vol. 3, 9th edn. Vieweg, Braunschweig

FS

Poggendorff compensation circuit — For the measurement of \rightarrow *electromotive force* (emf, E_{MF}) of a \rightarrow *galvanic cell* a compensation method, based on the principle of counter emf, was elaborated by \rightarrow *Poggendorff* in 1841 [i-ii]. Later it was developed further by others. The method is also called du Bois-Reymond-Poggendorff compensation method which is an acknowledgement of the contribution of Emil du Bois-Reymond (1798-1896). The zero current condition is established by using another power supply (**A**) which is connected with an opposite polarity. The currentless circuit is realized by changing the \rightarrow *resistances* of the potentiometer until the 'null indicator', i.e., the galvanometer (**G**) shows zero.

FS

The measurement is carried out as follows: The circuit of the \rightarrow *secondary battery* (**A**) or other power supply is closed by a measuring wire which is uniform in diameter, and is mounted on a board above a me-

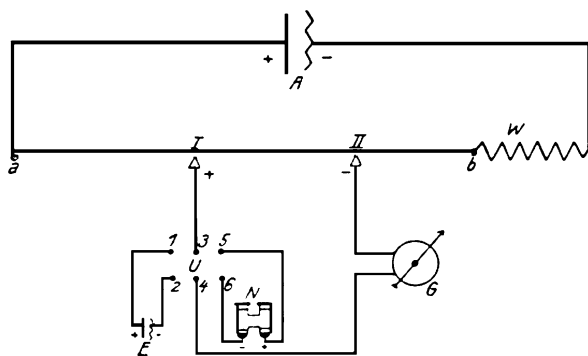

Poggendorff compensation circuit — **Figure**. The drawing of the Poggendorff compensation circuit [ii]

ter rule. The galvanic cell (E) whose emf to be measured is connected oppositely to the battery in the auxiliary circuit established between points **a** and **b**. By the help of the variation of the position of the sliding contact it can be achieved that the potential difference between points **I** and **II** will correspond to the emf of E cell, providing that its emf is smaller than that of the battery (A) which is usually 2 V. The contact at any intermediate point is done with a square-ended metal probe, which presses the wire on the scale ('tapping'). The switch is closed for an instant, and the galvanometer indicates the direction of the current. This technique permits length measurement to ± 1 mm which – choosing an appropriate **a–b** length – corresponds to 1 mV accuracy. Then the sub-circuit will be currentless which is indicated by the sensitive (ca. 10 μ A) center-reading galvanometer (G). Since the voltage of the battery may change, it is of importance to use a standard reference source which is usually a \rightarrow *Weston cell* developed by Edward Weston (1850–1936). The potential of the Weston cell is 1.0183 V at 25 °C, and it is very stable and reproducible. In the Figure this cell is marked by **N** which is related to the German name: "Normalelement" (\rightarrow *normal element*). Thus, the measurement is repeated by replacing E with N. The currentless situation is achieved in a different position of **II** which is denoted by **II'**. The ratio of the two different lengths (*l*) is equal to the ratio of the electromotive forces of E and N, respectively, i.e., $\text{emf (E)} : \text{emf (N)} = l (\text{I–II}) : l (\text{I–II}')$. The serial resistance **W** (rheostat) serves for the setting of the value of the current. It should be done when the test with the Weston element is carried out, and the value of the resistance should not be varied afterwards.

Instead of the measuring wire other types of resistances, resistance series, which are brought into the circuit by a dial-switch, can also be used.

The accuracy of the measurement has been enhanced by the application of 'compensators'. The principle of compensators was elaborated by Feussner in 1890 [iii]. The compensators worked with two or more identical series of resistances, sometimes combined with a \rightarrow *Wheatstone-bridge* and a Thomson-bridge. Many variants such as Franke-, Wilmshire-, Raps- or Siemens-Halske-, Lindeck–Rothe- etc. compensators were used.

With the appearance of the valve voltmeter (or vacuum tube electrometer) in 1935 (see \rightarrow *Beckman*) the compensation method has been gradually displaced from everyday laboratory practice [iv], and nowadays almost exclusively electronic \rightarrow *voltmeters* equipped with transistors and integrated circuits are being used.

Refs.: [i] Poggendorff JC (1841) *Pogg Am* 54:161; [ii] Jaeger W (1917) *Elektrische Messtechnik*. JA Barth, Leipzig, pp 278–285; [iii] Feussner K (1890) *Z Instrumentenkunde* 10:113; [iv] Selley NJ (1977) *Experimental approach to electrochemistry*. Edward Arnold, London, pp 64–66

GI

Point defects \rightarrow *defects in solids*

Point of zero charge (pzc) — The potential corresponding to zero electrode charge (the latter notion was introduced by \rightarrow *Frumkin* in 1928 [i]). Electrode charge (\rightarrow *charge density*) is the total quantity of electricity required to charge the interface up to its equilibrium state at certain potential under conditions of no charge exchange between the electrode surface and electrolyte bulk [ii]. The IUPAC definition can be found in [iii, iv]. Free and total surface charges (σ and Q , respectively) are used to be separated. The former characterizes a true excess electronic charge density of the electrode surface, while the latter includes both free and bonded charged species, i.e., presents also the charge reserved in the form of an electroactive substance. In general, the potentials of zero free and zero total charge differ from each other (excluding the \rightarrow *ideally polarizable electrodes*, for which the partial charge transfer is absent). If the electrochemically active component is dissolved, intercalated, or exists as a three-dimensional electroactive film at the electrode surface, the total charge should be normalized per material volume, not per surface area. The pzc is a basic feature of the electrode/solution \rightarrow *interface* playing a key role in \rightarrow *electrocapillary* and \rightarrow *electrokinetic phenomena*, affecting the interfacial structure (i.e., \rightarrow *adsorption* of ions and molecules), as well as physicochemical mechanics of solids, photoemission, and electron transfer at the interface. By introducing the pzc concept it is possible to solve the so-called Volta problem (the interplay of the contact potential drop at metal/metal interface and \rightarrow *emf* of the cell including the same metals as the electrodes). It became also possible to interpret numerous attempts to measure or compute the "absolute" electrode potential (\rightarrow *absolute potential*). In the absence of specific adsorption the difference in pzc of two metals can be reasonably compared with the difference in metal/vacuum \rightarrow *work functions* [v]. For semi-conducting electrodes, pzc is equal to the flat band potential. Pzc values depend on electrode and solution nature/composition, on surface crystallography and defectiveness. For metals adsorbing hydrogen and oxygen pzc are pH-dependent. The assumption of local pzc has been introduced for crystallographically different fragments of polycrystalline electrodes. The specific aspects of pzc

values for partly oxidized metals and their pzc interrelation with \rightarrow *isoelectric point* are considered in [vi]. Numerous techniques of experimental determination of the pzc have been developed. The most reliable pzc values are collected in [vii]. The highest accuracy of pzc values is achieved for mercury in NaF solutions, i.e., -0.472 V vs. SCE.

Refs.: [i] Frumkin A, Gorodetskaya A (1928) *Z phys Chem* 136:451; [ii] Frumkin A, Petrii O, Damaskin B (1970) *J Electroanal Chem* 27:81; [iii] Parsons R (1974) *Pure Appl Chem* 37:503; [iv] Trasatti S, Parsons R (1986) *Pure Appl Chem* 58:437; [v] Weaver M J (1998) *Langmuir* 14:3932; [vi] Duval J, Lyklema J, Mieke Kleijn J, van Leeuwen HP (2001) *Langmuir* 17:7573; [vii] Frumkin AN (1982) *Potentials of zero charge. Nauka, Moscow (in Russian)*

OR, GT

Poisson equation — In mathematics, the Poisson equation is a partial differential equation with broad utility in electrostatics, mechanical engineering, and theoretical physics. It is named after the French mathematician and physicist Siméon-Denis Poisson (1781–1840). In classical electrodynamics the Poisson equation describes the relationship between (electric) \rightarrow *charge density* and electrostatic potential, while in classical mechanics it describes the relationship between mass density and gravitational field. The Poisson equation in classical electrodynamics is not a basic equation, but follows directly from the Maxwell equations if all time derivatives are zero, i.e., for electrostatic conditions. The corresponding ('first') Maxwell equation [i] for the electrical field strength **E** under these conditions is

$$\nabla \mathbf{E} = \frac{\rho}{\varepsilon_r \varepsilon_0}, \quad (1)$$

where ε_0 is the \rightarrow *permittivity* of free space, ε_r is the relative permittivity, ρ is the (free) charge density, and ∇ stands for the nabla ('del' or 'gradient') operator $\nabla = \left[\frac{\partial}{\partial x}, \frac{\partial}{\partial y}, \frac{\partial}{\partial z} \right] \equiv \frac{\partial}{\partial x} \mathbf{e}_x + \frac{\partial}{\partial y} \mathbf{e}_y + \frac{\partial}{\partial z} \mathbf{e}_z$. (In the expression for the ∇ operator x, y , and z are Cartesian coordinates, $\mathbf{e}_x, \mathbf{e}_y$, and \mathbf{e}_z are the unit vectors). For problems of pure electrostatics – in which the electric fields are constant and there are no magnetic fields – the Maxwell equations may be simplified by writing the electric field in terms of an electric potential $\varphi(x, y, z)$, i.e., $\mathbf{E} = -\nabla \varphi(x, y, z)$.

Substituting this into Eq. (1), and defining the Laplacian or 'del-squared' operator $\nabla^2 = \Delta$ by $\nabla^2 \varphi(x, y, z) = \nabla \cdot \nabla \varphi(x, y, z) = \left[\frac{\partial^2}{\partial x^2}, \frac{\partial^2}{\partial y^2}, \frac{\partial^2}{\partial z^2} \right] \varphi(x, y, z)$, we arrive at the Poisson equation,

$$\nabla^2 \varphi(x, y, z) = -\frac{\rho(x, y, z)}{\varepsilon_r \varepsilon_0}. \quad (2)$$

(Evidently, for vanishing ρ , this equation simplifies to the Laplace equation $\Delta \varphi = 0$.)

To determine the spatial variation of a static electric field, one has to solve the Poisson equation for the appropriate charge distribution, subject to such boundary conditions as may pertain. The Poisson equation plays a central role in the Gouy–Chapman (\rightarrow *Gouy*, \rightarrow *Chapman*) electrical \rightarrow *double layer* model and in the \rightarrow *Debye–Hückel theory* of electrolyte solutions. In the first case the one-dimensional form of Eq. (2)

$$\frac{d^2 \varphi(x)}{dx^2} = -\frac{\rho(x)}{\varepsilon_r \varepsilon_0} \quad (3)$$

is used [ii], while in spherical symmetry, which is relevant for the Debye–Hückel theory Eq. (2) has the form [iii]

$$\frac{1}{r^2} \frac{\partial}{\partial r} \left[r^2 \frac{\partial \varphi(r)}{\partial r} \right] = -\frac{\rho(r)}{\varepsilon_r \varepsilon_0}. \quad (4)$$

The Poisson equation can also be used in modelling \rightarrow *charge transport* phenomena in \rightarrow *semiconductors* and \rightarrow *conductive polymers* [iv, v].

Refs.: [i] Feynman RP, Leighton RB, Sands M (1964) *The Feynman lectures on physics. Addison-Wesley Publishing, Reading, p 4-1*; [ii] Reeves R (1980) *The double layer in the absence of specific adsorption. In: Bockris JO'M, Conway BE, Yeager E (eds) Comprehensive treatise of electrochemistry, vol. 1. Plenum Press, New York, pp 105–110*; [iii] Oldham KB, Myland JC (1993) *Fundamentals of electrochemical science. Academic Press., San Diego, pp. 40–45*; [iv] Wang S (1966) *Solid-state electronics. McGraw-Hill, New York, p 284*; [v] Láng G, Inzelt G (1999) *Electrochim Acta* 44:2037

GGL

Poisson–Boltzmann equation — The Poisson–Boltzmann equation is a nonlinear, elliptic, second-order, partial differential equation which plays a central role, e.g., in the Gouy–Chapman (\rightarrow *Gouy*, \rightarrow *Chapman*) electrical \rightarrow *double layer* model and in the \rightarrow *Debye–Hückel theory* of electrolyte solutions. It is derived from the classical \rightarrow *Poisson equation* for the electrostatic potential

$$\nabla^2 \varphi(x, y, z) = -\frac{\rho(x, y, z)}{\varepsilon_r \varepsilon_0}, \quad (1)$$

and using the \rightarrow *Boltzmann distribution function*

$$n_i = n_\infty \exp\left(-\frac{\omega_i}{k_B T}\right) \quad (2)$$

to model the charge distribution in the solution. In Eq. (1) $\varphi(x, y, z)$ is the electric potential, ε_0 is the \rightarrow *permittivity* of free space, ε_r is the relative permittivity, ρ is

the (free) \rightarrow charge density, and ∇ stands for the nabla operator. In Eq. (2) n_∞ is the mean distribution at “far-field” (“far-field” in this context is used to refer to regions of space that for practical purposes can be considered as being at infinity, i.e., the variation of energy with distances within these regions is negligible), k_B is the \rightarrow Boltzmann constant, and T is the absolute temperature of the system. The assumption made while deriving Eq. (2) is that the probability of finding n_i particles with energy ω_i ($i = 1, 2, 3$) is respectively proportional to the number of possible ways of distributing them so.

In the Gouy model the \rightarrow Boltzmann equation based on Eq. (2) is the primary relation describing the interplay of electrostatics and thermal motion [i, ii]. The local concentrations of the i -th ionic species at the distance x from the interface is given as a function of the local potential $\varphi(x)$ as

$$c_i(x) = c_{i,\infty} \exp\left[-\frac{z_i F \varphi(x)}{RT}\right]. \quad (3)$$

In Eq. (3) $c_{i,\infty}$ is the bulk concentration of the i -th ionic species with charge number z_i at a sufficiently large distance from the interface, F and R are the \rightarrow Faraday constant and \rightarrow gas constant, respectively. The local charge density is then

$$\rho(x) = \sum_i z_i F c_{i,\infty} \exp\left[-\frac{z_i F \varphi(x)}{RT}\right], \quad (4)$$

where i runs over all ionic species.

Equation (4) and the one-dimensional form of Eq. (1) can be combined to yield the one-dimensional form of the (nonlinear) Poisson–Boltzmann equation:

$$\frac{d^2 \varphi(x)}{dx^2} = -\frac{F}{\epsilon_r \epsilon_0} \sum_i z_i c_{i,\infty} \exp\left[-\frac{z_i F \varphi(x)}{RT}\right]. \quad (5)$$

In an electrolyte solution the ions are interspersed by water molecules, moreover they are subject to thermal motion. Debye and Hückel simplified the description of this problem to a mathematically manageable one by considering one isolated ion in a hypothetical, uniformly smeared-out sea of charge, the ionic cloud, with the total charge just opposing that of the ion considered. For this case the Poisson equation in terms of spherical coordinates is given by

$$\frac{1}{r^2} \frac{\partial}{\partial r} \left[r^2 \frac{\partial \varphi(r)}{\partial r} \right] = -\frac{\rho(r)}{\epsilon_r \epsilon_0} \quad (6)$$

where r is the radial distance from the central ion [i, iii]. The resulting Poisson–Boltzmann equation is quite sim-

ilar to that of Gouy, except that the geometry is a spherical one:

$$\frac{1}{r^2} \frac{\partial}{\partial r} \left[r^2 \frac{\partial \varphi(r)}{\partial r} \right] = -\frac{F}{\epsilon_r \epsilon_0} \sum_i z_i c_{i,\infty} \exp\left[-\frac{z_i F \varphi(r)}{RT}\right]. \quad (7)$$

In the limit of low potential φ , the right-hand side of the Poisson–Boltzmann equation can be linearized by using the first two terms of its Taylor series to get the linearized Poisson–Boltzmann equation:

$$\frac{1}{r^2} \frac{\partial}{\partial r} \left[r^2 \frac{\partial \varphi(r)}{\partial r} \right] = \left(\frac{1}{\beta}\right)^2 \varphi(r) \quad (8)$$

where β is a constant with the dimension of length. This approach is frequently used in theoretical descriptions, but it suffers from some consistency problems related to the validity of linearization. However, it should be noted that the complete nonlinear Poisson–Boltzmann equation is inconsistent with the linear superposition principle, while in the case of the linearized Poisson–Boltzmann equation the superposition principle for the electrostatic potential is valid.

Refs.: [i] de Levie R (1999) *J Chem Educ* 76:129; [ii] Reeves R (1980) *The double layer in the absence of specific adsorption*. In: Bockris JOM, Conway BE, Yeager E (eds) *Comprehensive treatise of electrochemistry*, vol. 1. Plenum Press, New York, pp 105–110; [iii] Wedler G (1985) *Lehrbuch der Physikalischen Chemie*. VCH, Weinheim, pp 203–205

GGL

Polanyi, Michael (Polányi Mihály)



(Mar. 11, 1891, Budapest, Hungary (Austro-Hungarian Empire) – Feb. 22, 1976, Oxford, UK) Polanyi completed his medical studies at Budapest University and became a physician. While serving as a medical officer during World War I, he worked on the application of quantum theory to the third law of thermodynamics and on the thermodynamics of adsorption. In 1920 Polanyi received an appointment to the Institute of Fiber Chemistry in Berlin where he dealt with the X-ray diffraction of cellu-

lose fibers. From 1923 he worked in the Kaiser Wilhelm Institute of Physical Chemistry in Berlin. Here he carried out fundamental studies in gas kinetics which led to the later work in chemical dynamics. Polanyi started to use contour maps for representing the potential energy of the species participating in chemical reactions. Polanyi with Henry Eyring (1901–1981) – who came from Wisconsin to study with him – worked on the calculation of \rightarrow activation energy using this entirely new approach [i, ii]. In 1933 he left Germany and became a professor of physical chemistry at the University of Manchester. There, the transition-state theory was developed [iii] which practically replaced the kinetic theory of collisions later on. Polanyi with \rightarrow Horiuti explained the physical meaning of the \rightarrow transfer coefficient (α) by the help of the transition-state theory which was a milestone in the development of the kinetics of electrode processes [iv, v].

From 1936 Polanyi increasingly turned his attention from science to economics and philosophy, and after the Second World War he dealt exclusively with these subjects. He became a professor of social sciences. That status was created for him at the University of Manchester where he stayed until he became a Fellow at Merton College Oxford in 1959.

From the many readings available about Polanyi's life and scientific career two are recommended herein; one is written by Eugen P. Wigner (1902–1995, Nobel Prize 1963) who was Polanyi's student in Berlin in the 1920s and lifelong friend [vi], and the other by his son John C. Polanyi (1929–, Nobel Prize in Chemistry 1986) who continued the family tradition regarding the study of reaction dynamics [vii]. Additional information on Polanyi can be found on the Polanyi Society homepage [viii]. See also \rightarrow Polanyi's rule.

Refs.: [i] Polanyi M, Eyring H (1930) *Naturwissenschaften* 18:914; [ii] Polanyi M (1932) *Atomic reactions*. William & Norgate, London; [iii] Polanyi M, Evans MG (1935) *Trans Faraday Soc* 31:875; [iv] Horiuti J, Polanyi M (1935) *Acta Physicochim URSS* 2:505; [J Mol Catal (2003) 199:185]; [v] Inzelt G (2006) *Russian J Electrochem* 42:109; [vi] Wigner EP, Hodgkin RA (1977) *Michael Polanyi, Biog memoirs of FRSS*, vol. 23. London; [vii] Polanyi JC (2003) *Polanyiana* 12:117; [viii] <http://www.mwsc.edu/orgs/polanyi>

Polanyi's rule \rightarrow Polanyi and co-workers [i–iii] established that for homologous reaction series a simple linear relationship exists between the \rightarrow activation energy (Q) and the heat of reaction ($\Delta\chi$):

$$\Delta Q = -\alpha \Delta\chi,$$

where α is a proportionality factor (Fig. 1). This is a \rightarrow linear free energy relationship.

It also has been shown that similar reasoning can be used to interpret the relationship between the activation energy and the variation of electrode potential (ε) (Fig. 2) as well as between the activation energy and the energy of adsorption (W) (Fig. 3).

Today Polanyi's rule is used in the following form:

$$\Delta G^\ddagger = \alpha \Delta G \quad (1)$$

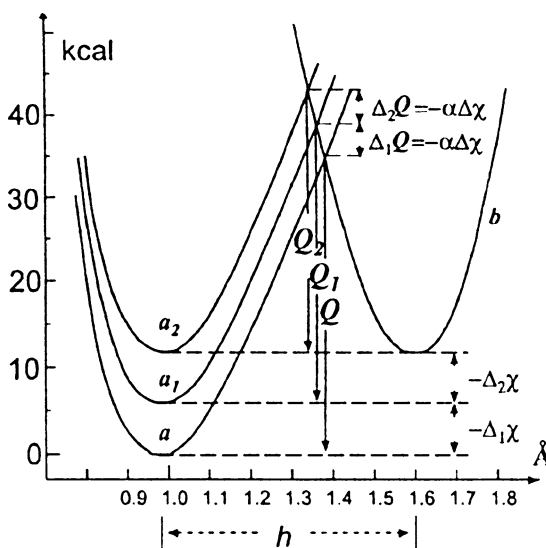

Polanyi's rule — Figure 1. Illustration of the relationship between Q and $\Delta\chi$ from [i]

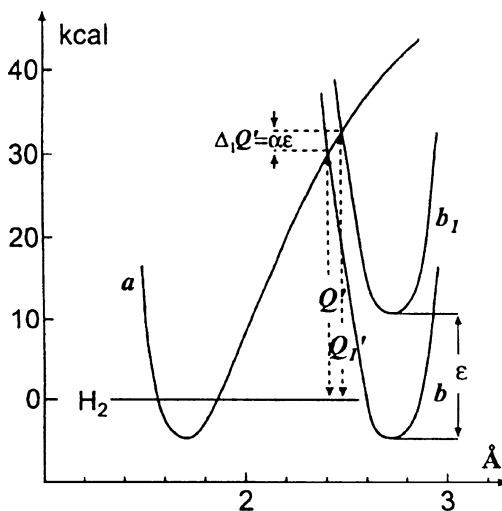

Polanyi's rule — Figure 2. Illustration of the relationship between the energy of activation of ionization/deionization processes (Q) and the electrode potential (ε) [i]

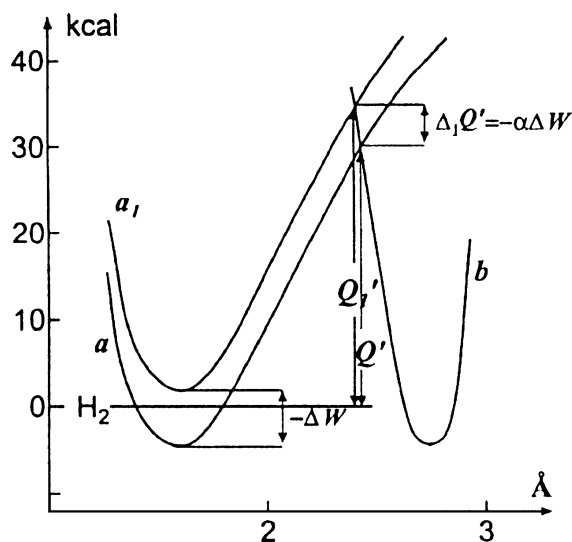

Polanyi's rule — Figure 3. Illustration of the relationship between the energy of activation (Q) and the energy of adsorption of hydrogen atoms (W) [i]

where ΔG^\ddagger is the \rightarrow Gibbs energy of activation and ΔG is \rightarrow Gibbs energy change of the reaction (\rightarrow activation overpotential, \rightarrow charge-transfer coefficient).

Refs.: [i] Horiuti J, Polanyi M (1935) *Acta Physicochim URSS* 2:505; [ii] Evans MG, Polanyi M (1936) *Trans Faraday Soc* 32:1333; [iii] Evans MG, Polanyi M (1938) *Trans Faraday Soc* 34:1138

GI

Polarity of electrodes — (a) Two-electrode systems:

The polarity of each \rightarrow electrode of a \rightarrow galvanic cell or of an \rightarrow electrolysis cell depends on the relative \rightarrow potential of that electrode versus the other. In case of two different electrodes, one electrode will always be the positive one and the other the negative. This property is independent of whether the cell is being charged or discharged. Example: Consider a zinc electrode is immersed in a Zn^{2+} solution and a copper electrode immersed in a Cu^{2+} solution, separated by a \rightarrow diaphragm (\rightarrow Daniell cell). The zinc electrode is the negative \rightarrow pole and the copper electrode is the positive pole, regardless of the direction of current flow. Thus, when the cell is charged, zinc metal is deposited from the Zn^{2+} ions in solution and copper metal dissolves as Cu^{2+} ions in solution. In this case, the negative electrode (the zinc) is the cathode, and the positive electrode (the copper) is the anode. Conversely, when the cell is discharged, zinc metal dissolves as Zn^{2+} ions in solution, and copper metal is deposited from the Cu^{2+} ions in solution. Now the negative electrode (the zinc) is the anode, and the positive electrode (the cop-

per) is the cathode, but the polarity of the cell is unchanged. At equilibrium (neither charge nor discharge) the sign and magnitude of the cell polarity depend only upon the \rightarrow formal potentials of the metal electrodes in their respective solutions, plus a small \rightarrow liquid junction potential associated with the diaphragm. (b) **Multi-electrode systems:** The polarity of each electrode can be given only with respect to individual electrodes.

(The terms 'cathodic' and 'anodic' pertain to the direction of current flow (not potential) and it is considered bad practice to use them to describe electrode polarity.)

FS

Polarity of molecules — If applied to molecules, the polarity term refers to those of permanently separated positive and negative charge (e.g., HCl , O_3 , NH_3) to form permanent \rightarrow dipoles, characterized by electrical \rightarrow dipole moments. This charge separation arises from the difference in electronegativity of atoms or other bond properties. Only molecules belonging to the C_n , C_{nv} , and C_s symmetry groups have permanent dipole moments. In molecules belonging to the C_n and C_{nv} groups, this moment is directed along the molecule axis of rotation. An external electric field applied may temporarily modify the molecule polarity.

Refs.: [i] Muller P (1994) *Pure Appl Chem* 66:1077; [ii] Atkins P (1998) *Physical chemistry*. Oxford University Press, Oxford

WK

Polarity of solvents — If applied to solvents, this rather ill-defined term covers their overall \rightarrow solvation capability (solvation power) with respect to solutes (i.e., in chemical equilibria: reactants and products; in reaction rates: reactants and activated complex; in light absorptions: ions or molecules in the ground and excited state), which in turn depends on the action of all possible, nonspecific and specific, intermolecular interactions between solute ions or molecules and solvent molecules, excluding interactions leading to definite chemical alterations of the ions or molecules of the solute. Occasionally, the term solvent polarity is restricted to nonspecific solute/solvent interactions only (i.e., to \rightarrow van der Waals forces).

Refs.: [i] Muller P (1994) *Pure Appl Chem* 66:1077; [ii] Atkins P (1998) *Physical chemistry*. Oxford University Press, Oxford

WK

Polarizable electrode — When current flows through an \rightarrow electrode it changes the \rightarrow electrode potential. This phenomenon is called \rightarrow polarization. Until the appearance of the \rightarrow potentiostat (constructed by A. Hickling

[1908–1975]) in 1942 the current was the controlled and the potential the measured quantity, i.e., the \rightarrow *galvanostatic technique* was used. The term ‘polarization’ is dated back from the early period of electrochemistry. There are two limiting cases: (a). When the \rightarrow *charge carriers* (ions, electrons) do not cross the metal|solution interface there is only a change of the amount of charge of the double-layer capacitor and a change of the potential difference across its “plates”. Systems which behave in this manner are \rightarrow *ideally polarizable electrodes*. On the other hand (b), if the rate of \rightarrow *charge transfer*, i.e., the \rightarrow *exchange current density* (j_o) is very large, the \rightarrow *depolarization* is strong. The potential of such electrodes is practically unaffected by small current densities ($j \ll j_o$). These are the ideally \rightarrow *nonpolarizable electrodes*.

The behavior of the real electrodes falls within these limits, i.e., the current changes their potentials, consequently these are termed polarizable electrodes.

The potential change upon the effect of the current density (j) is quantitatively described by the \rightarrow *Tafel equation*, and \rightarrow *Butler–Volmer equation*.

The potential of the electrode can be varied not only by a current supplied by an external current source but also by changing the composition of the electronically conducting phase or, which is more frequently the case (see, e.g., \rightarrow *potentiometry*), the composition of the ionically conducting phase (solution) of the electrode.

Polarizability (of a molecule) — There are numerous different mechanisms that contribute to the total polarizability of a molecule. The three most important of these are termed electron polarizability, molecular-distortion polarizability, and orientation polarizability. All these parameters are measured as statistical averages over large numbers of molecules present in the bulk phase. (1) \rightarrow *Electron polarizability* α is a measure of the ease with which electrons tend to be displaced from their zero-field positions by the applied \rightarrow *electric field*. Thus, the electron polarizability of a molecule is defined as the ratio of induced dipole moment μ_{ind} (coulomb meters) to the inducing electric field E (volts per meter):

$$\alpha = \frac{\mu_{\text{ind}}}{E}.$$

The SI units of polarizability are $\text{Cm}^2 \text{V}^{-1}$. In the older literature, electron–nucleus polarizability was often defined as

$$\alpha' = \frac{\alpha}{4\pi\epsilon_0}$$

so that the units were cm^3 . Here ϵ_0 is the vacuum \rightarrow *permittivity* ($8.854 \times 10^{-12} \text{Fm}^{-1}$).

(2) *Molecular distortion polarizability* is a measure of the ease with which atomic nuclei within molecules tend to be displaced from their zero-field positions by the applied electric field. (3) *Orientation polarizability* is a measure of the ease with which dipolar molecules tend to align against the applied electric field. The electron polarizability of an individual molecule is related to the \rightarrow *permittivity* (relative) of a dielectric medium by the \rightarrow *Clausius–Mossotti relation*.

SF

Polarization (of an electrode) — For a \rightarrow *cell* or an \rightarrow *electrode* that has a defined equilibrium potential (see \rightarrow *equilibrium electrode potential*), a departure of the electrode (or cell) potential (E) from its equilibrium value (E_{eq}) is called polarization. The measure of the magnitude of polarization is called the \rightarrow *overpotential* and is marked by symbol η : $\eta = E - E_{\text{eq}}$.

An \rightarrow *ideal nonpolarizable electrode* is one whose potential does not change as current flows in the cell. Much more useful in electrochemistry are the electrodes that change their potential in a wide potential window (in the absence of a \rightarrow *depolarizer*) without the passage of significant current. They are called \rightarrow *ideally polarized electrodes*. Current–potential curves, particularly those obtained under steady-state conditions (see \rightarrow *Tafel plot*) are often called polarization curves. In the \rightarrow *corrosion* measurements the ratio of $\Delta E/\Delta I$ in the polarization curve is called the polarization resistance. If during the \rightarrow *electrode processes* the overpotential is related to the \rightarrow *diffusional* transport of the depolarizer we talk about the concentration polarization. If the electrode process requires an \rightarrow *activation energy*, the appropriate overpotential and activation polarization appear.

Refs.: [i] Brett CMA, Brett MOB (1996) *Electrochemistry. Principles, methods, and applications*. Oxford University Press, Oxford; [ii] Bard AJ, Faulkner LR (2001) *Electrochemical methods*, 2nd edn. Wiley, New York; [iii] Scholz F (ed) (2002) *Electrochemical methods*. Springer, Berlin

ZS

Polarization curve \rightarrow *polarization*

Polarization density (of a dielectric medium) — The polarization density P is the difference between the electric displacement in a \rightarrow *dielectric* medium D_C and the electric displacement in a vacuum D_O . (Note: The electric displacement is defined as the product of the electric field strength E and the \rightarrow *permittivity* ϵ .) The polarization density of a dielectric medium may also be

thought of as the volume density of permanent and induced dipole moments. The units of polarization density D are therefore coulomb-meters per cubic meter, i.e. coulombs per square meter (C m^{-2}).

Polarization resistance → *polarization*

Polarogram — A plot depicting the measured current versus the potential applied to a → *dropping mercury electrode* (DME). If a → *hanging mercury drop electrode* (HMDE) or a solid electrode is used, the term → *voltammogram* should be used instead of polarogram, which by definition, specifically implies the use of a DME as the working electrode [i]. Different kinds of potential ramps can be applied to a DME and thus, diverse sorts of polarograms can be obtained [ii]. Some of these potential scans and the respective polarographic curves are shown in the following Figure. See also → *polarography*.

Refs.: [i] Bond AM (1999) *Anal Chim Acta* 400:333; [ii] Brett CMA, Oliveira Brett AM (1994) *Electrochemistry. Principles, methods, and applications*. Oxford University Press, Oxford

FG

Polarograph — Instrument developed by → *Heyrovský* and → *Shikata* for performing → *polarography* (which is a variant of what is now called → *voltammetry*). The name is derived from → *polarization* and 'graph', since a polarization curve is recorded. In the first polarograph a → *helical potentiometer* (Kohlrausch's drum), driven

by a spring motor, provided a continuously varied voltage to the set of two electrodes dipping into the electrolytic cell, one nonpolarizable and one polarizable, formed by dropping mercury. A mirror galvanometer was used to measure the ensuing current. A narrow light beam from a lamp was reflected from the mirror of the galvanometer to photographic paper that was wound around a cylinder revolving in a cylindrical case with a closing slit; the cylinder was mechanically coupled to

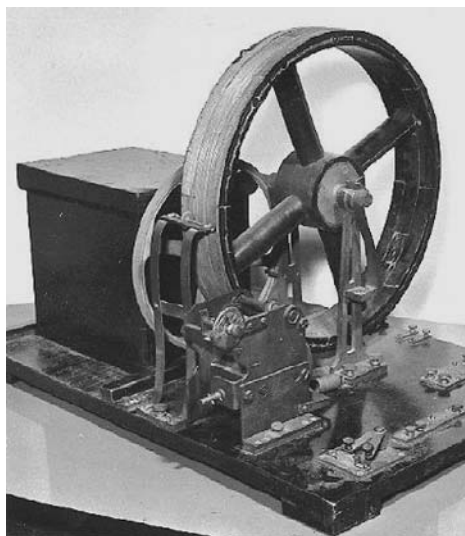

Polarograph — Figure 1. The first polarograph from 1924. (Courtesy of Heyrovský Institute of Physical Chemistry, Prague)

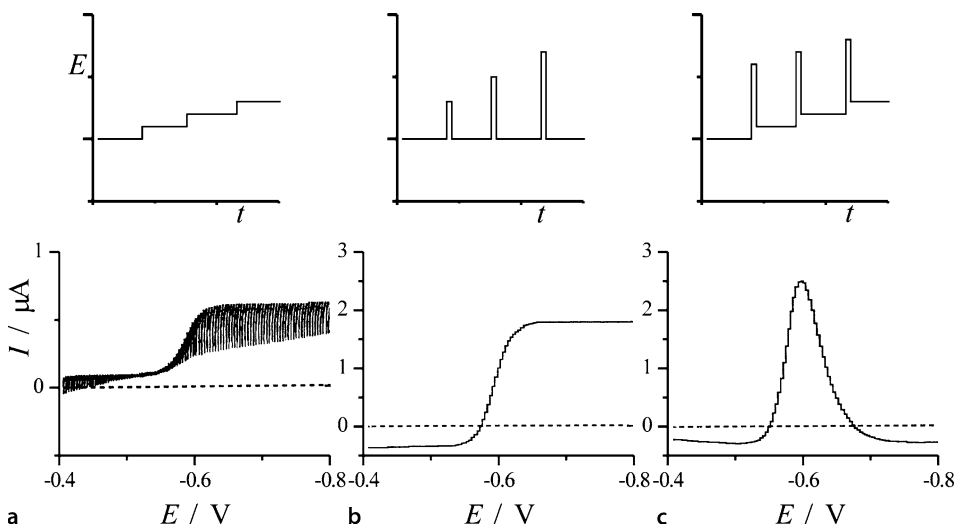

Polarogram — Figure. Potential program and the respective (a) direct current (DC) (staircase ramp), (b) normal pulse (NP) and (c), differential pulse (DP) polarograms of $0.1 \text{ mM Cd}(\text{NO}_3)_2$. All measurements were in water with 0.1 M KCl , E is versus a SCE, scan rate = 2 mVs^{-1} and drop time = 2 s . Differential pulse height = 10 mV

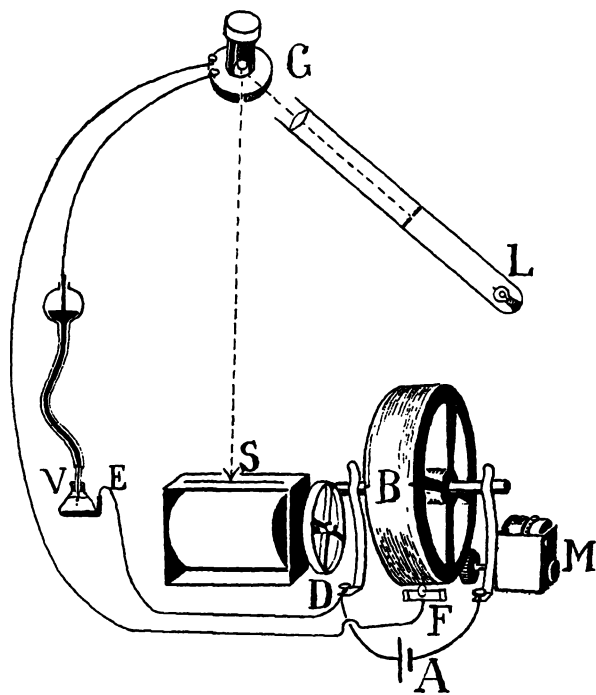

Polarograph — **Figure 2.** The parts of the first polarograph together with the polarographic cell: A is the battery, B is the helical potentiometer, G is a mirror galvanometer, M is the clock-work to drive the potentiometer and the cylinder with the photographic paper in the box D, F is the sliding contact to the potentiometer, V is the polarographic cell with the dropping mercury electrode, E is the contact wire to the bottom mercury, L is the light source, and S is the slit through which the light beam coming from the mirror galvanometer is directed on the photographic paper (reproduced from [1])

the helical potentiometer. Figure 1 shows the first polarograph from 1924 (without the galvanometer) and Fig. 2 shows the experimental setting. More advanced polarographs (voltammetric instruments) used electronic circuits with pen recorders and allowed applying also various other than DC continuous forms of polarizing voltage to the electrodes. Later instruments were built on → *operational amplifiers* and digital data processing. The recent polarographs (voltammetric measuring stations) are computer-controlled with programmable performance.

Ref.: [1] Heyrovsky J, Shikata M (1925) *Rec Trav Chim* 44: 496

FS

Polarographic maximum — A peak-shaped current signal that is caused by enhanced streaming of the solution, or mercury and solution, in measurements with a → *dropping mercury electrode* (DME) and sometimes also on → *stationary mercury drop electrodes* (SMDE). Two different types are to be distinguished: (a) Polarographic

maxima of the first kind: they are characterized by a steep current increase at the ascending part of either polarographic reduction or oxidation waves, reaching values several times higher than the limiting wave current, and then dropping quickly to the limiting current values. Maxima of the first kind occur in diluted electrolyte solutions. The reason of that kind of maxima is a streaming of the electrolyte solution in the surrounding of the electrode, caused by potential differences on the surface of the mercury drop, due to changes of surface activity of the electroactive species in the course of electrode reaction (see also → *Marangoni streaming*). The potential differences are caused by an uneven current density distribution on the drop surface. The streaming of the solution can be directed upwards or downwards with respect to the glass capillary. (b) Polarographic maxima of the second kind: These are rounded peaks on top of oxidation or reduction waves. They occur usually in electrolyte solutions with concentrations higher than 0.1 mol L^{-1} . The reason for that effect is a fast flow of mercury into the growing droplets when the pressure of mercury above the capillary tip is unduly high. An accompanying streaming of the solution layer adjacent to the electrode surface leads to an enhanced mass transfer of depolarizer, and thus to a current increase. The solution always streams in the direction upwards to the capillary. The cause of maxima of the second kind is of pure hydrodynamic origin – it can be removed from the curve by lowering the pressure of mercury above the capillary tip. The strong streaming of the mercury inside the growing droplets is of pure hydrodynamic origin, has always the same pattern, and always causes the solution to stream upwards to the capillary.

Both kinds of maxima can be suppressed by addition of → *surface-active substances*, for the analysis of which that effect has been used.

Ref.: [1] Heyrovský J, Kůta J (1965) *Grundlagen der Polarographie*. Akademie-Verlag, Berlin, pp 401 (Engl transl: Heyrovský J, Kůta J (1965) *Principles of polarography*. Academic Press, New York, pp 429)

FS

Polarographic titration → *amperometric titration*

Polarography — is an electroanalytical technique involving recording of current-voltage ($I-E$) curves using a mercury electrode with a continuously renewed surface, i.e., the → *dropping mercury electrode* (DME). This electrode is used as → *working electrode* in a two- or three-electrode arrangement. In recording current-voltage curves using such arrangement, the voltage is

usually changed relatively slowly, at a rate varying between 1 and 5 mV/s. In this way the potential during the life of every drop varies only by a maximum of 15 mV. The total potential range scanned for a single I - E curve is up to 2 volts. The currents measured in polarography are thus recorded at an almost constant potential for each drop. Polarographic curves show current oscillations, caused by the repetitive drop growth and drop detachment. The increase of the instantaneous current during the life of a single drop with time has a shape of a parabola with an exponent varying from 1/6 (for electrochemically reversible systems (\rightarrow reversibility) at potentials along the whole ascending part of the wave) to 2/3, depending on the nature of the electrode process. This increase is followed by a sudden decrease in current, due to the detachment of the drop from the mercury column and the rise of a new drop. Usually damped recording systems are used, and mean currents are measured. The majority of theoretical expressions has been derived for these mean currents. The regularity of oscillations is a good indicator of a well-functioning dropping electrode. Furthermore, the shape of these oscillations can offer in some instances useful information about the nature of the electrode process, for example, adsorption or presence of a charging current. The main advantage of the use of the DME is the reproducibility of recorded current-voltage curves due to the renewal of the electrode surface. The surface of each drop is fresh and unaffected by previous processes, thus an onset of such phenomena, such as adsorption, is well defined. Another advantage of DME is a high hydrogen \rightarrow overpotential: Hydrogen ions are reduced only at rather negative potentials (the actual potential of H^+ reduction is shifted to more negative values with increasing pH). As numerous reductions, both of inorganic and organic species, take place at negative potentials, the potential window available in polarography is particularly useful for reduction processes. The positive limit of the \rightarrow potential window is mainly set by the anodic dissolution of mercury, which depends on the anion present. The most positive potential that can be reached is about +0.4 V (SCE). Polarography remains a useful tool, although infrequently used, in the initial stages of investigations of the nature of electrode processes, for example, in the determination of the number of transferred electrons (n) or for detection and identification of chemical reactions accompanying the electrode transfer. – In classical (DC) polarography it is usually possible to analyze solutions containing 1×10^{-3} to 5×10^{-6} mol L $^{-1}$ electroactive species. Reaching a higher sensitivity is prevented by the presence of the \rightarrow charging current. Minimizing the effect of

this charging current was one of the main goals of the development of modern variants of polarography, of which more than 50 have been reported. The most frequently used ones are described below. They differ mainly in the way in which the voltage is applied to the \rightarrow working electrode and in the way in which the current is measured.

Refs.: [i] Heyrovský J, Kůta J (1966) *Principles of polarography*. Academic Press, New York; [ii] Meites L (1965) *Polarographic techniques*, 2nd edn. Wiley Interscience, New York; [iii] Bond AM (1980) *Modern polarographic methods in analytical chemistry*. Marcel Dekker, New York; [iv] Meites L, Zuman P (1976–1983) *Handbook series in organic electrochemistry*, vols. I–VI. CRC Press, Boca Raton

PZ

AC polarography — Polarographic techniques in which an \rightarrow alternating voltage is superimposed to a slowly and linearly increasing or decreasing potential ramp are called alternating current (AC) **polarography**, provided a \rightarrow dropping mercury electrode is used. The wave forms of the AC voltage can be rectangular (square-wave), triangular, or sinusoidal. The latter one and the square-wave (\rightarrow square-wave voltammetry/polarography) are most frequently used. The sinusoidal AC polarography will be discussed below. The amplitude of the sinusoidal voltage is usually small (10–50 mV) and the frequency is constant. The linear potential ramp is the same as in DC polarography, with a scan rate of 2 to 5 mV s $^{-1}$. The AC current is amplified and recorded versus the DC potential. The shape of the resulting current-voltage curve shows a characteristic peak. Peaks with one maximum are obtained when it is the fundamental harmonic alternating current, which is plotted as a function of the DC voltage. The peak current (I_p) is usually a linear function of the concentration of the electroactive species. The value of the peak potential (E_p) is close to that of $E_{1/2}$ in DC polarography and depends on the nature of the electroactive species present and on composition of the supporting electrolyte. Characteristics of the electrode process, both kinetic and thermodynamic, affect both E_p and I_p and the shape of the I - E curve. Electrochemically reversible processes give higher and narrower peaks which can be observed also at lower concentrations than those of electrochemically irreversible processes, which are characterized by low and broad peaks. The AC current can be recorded at the same phase as that of the applied alternating voltage. Phase-selective current measurements allow separating the capacitive and faradaic currents. This is possible because the capacitive (charging) current is 90° out of phase with the applied alternating voltage, whereas the faradaic current is only 45° out of phase. AC polarography can also be applied to compounds that

are neither reduced or oxidized at the dropping mercury electrode, but are adsorbed within the investigated potential range. This form of application of AC polarography is called \rightarrow *tensammetry*. It considerably extends the scope of application of polarography to a large group of compounds which otherwise would not be possible to follow using other polarographic techniques.

See also \rightarrow *AC voltammetry*.

Refs.: [i] Bond AM (1980) *Modern polarographic methods in analytical chemistry*. Marcel Dekker, New York; [ii] Galus Z (1994) *Fundamentals of electrochemical analysis*, 2nd edn. Ellis Horwood, New York, Polish Scientific Publisher PWN, Warsaw; [iii] Breyer B, Bauer HH (1963) *Alternating current polarography and tensammetry*. Interscience, New York; [iv] Bard AJ, Faulkner LR (2001) *Electrochemical methods*, Wiley, New York, pp 388–396; [v] Smith DE (1966) *Electroanalytical chemistry*. In: Bard AJ, ed, Marcel Dekker, New York, vol. 1, chap 1

PZ

DC polarography — This is the oldest variant of polarographic techniques, invented by \rightarrow *Heyrovský*. The applied voltage varies linearly with time and the resulting current-voltage curves have the shape of a wave. In most instances, the \rightarrow *limiting currents* are a linear function of concentration between 1×10^{-3} and 5×10^{-6} mol L⁻¹. The electrode process is qualitatively characterized by the potential at the current-voltage curve, where the current reaches half of its limiting value. This is the so-called \rightarrow *half-wave potential* ($E_{1/2}$), which, in most instances, is practically independent of the concentration of the electroactive species. For electrochemically reversible systems the half-wave potential is approximately equal to the \rightarrow *formal potential*, provided that no amalgam formation is involved (\rightarrow *Gibbs energies of amalgam formation*) and for equal \rightarrow *diffusions coefficients* of the oxidized and reduced forms. In solutions containing several electroactive species in a mixture, the current-voltage curves show separate waves if the half-wave potentials of individual species differ by more than about 0.10 V. The limiting currents corresponding to electrolysis of individual species are usually additive. This allows determining the number of electrons (n) for an unknown electrode process. This is achieved by comparing the limiting currents of the unknown with limiting currents of several species of similar size, for which the value of n is known. As the diffusion coefficients of such species differ only slightly, the ratios of limiting currents are practically proportional to the ratios of the n values. Measurements of limiting currents also enable identification of chemical reactions accompanying the electron transfer and often in combination with shifts of half-wave potential determination of equilibrium or rate constants of such reactions.

See also \rightarrow *linear scan voltammetry*, and \rightarrow *cyclic voltammetry*.

Refs.: [i] Heyrovský J, Kůta J (1966) *Principles of polarography*. Academic Press, New York; [ii] Meites L (1965) *Polarographic techniques*, 2nd edn. Wiley Interscience, New York; [iii] Bond AM (1980) *Modern polarographic methods in analytical chemistry*. Marcel Dekker, New York; [iv] Galus Z (1994) *Fundamentals of electrochemical analysis*, 2nd edn. Ellis Horwood, New York, Polish Scientific Publisher PWN, Warsaw

PZ

Differential pulse polarography — In differential pulse polarography (DPP) a linearly increasing voltage ramp is superimposed by small amplitude (usually about 50 mV) voltage pulses. To minimize the effect of \rightarrow *charging current* the pulses are applied towards the end of the drop-life, where the electrode surface is almost constant and the current is measured both at a potential before the application of the pulse and during the last 10–20% of the duration of the pulse. The difference between the current measured before the pulse rise and the current measured towards the end of the pulse is plotted as a function of the applied potential. As such plots are analogous to a derivative of the current-voltage curve obtained in DC or normal pulse polarography, the record of the current difference as a function of the applied voltage has the shape of a peak. The peak current (I_p) is usually a function of the concentration of the electroactive species and the plot of $I_p = f(c)$ is usually linear. The maximum of the peak occurs at a potential (E_p) that is close to the value of $E_{1/2}$ obtained in DC polarography. In the presence of two or more electroactive species in the analyzed solution, two or more peaks may be observed on the I - E curve. In such cases peak currents are a simple linear function of concentration of the species reduced at E_p , when the current between the peaks decreases close to the current, observed in a blank, containing only the supporting electrolyte. This can be achieved in practice when the values of the two E_p differ by more than about 0.15 V. When the reduction potentials differ by less than this value, the peaks overlap and a deconvolution treatment has to be used. The simple additivity, observed for limiting currents in DC polarography does not apply here. The shapes of the peaks depend on the shape of I - E curves in DC polarography. It can be affected by the rate of the electrode process, by the presence of chemical reactions accompanying the electron transfer, and by the presence and concentration of surface-active substances. The greatest advantage of DPP is the increased sensitivity, allowing detection of various species up to the 1×10^{-8} M level.

Due to its high sensitivity, DPP is particularly useful for trace analysis, e.g., for forensic or environmen-

tal science. For quantitative evaluation the use of standard addition is preferred. When calibration curves are used for such purposes, it is essential that the composition of the matrix and of the supporting electrolyte and the concentration of surfactants be as similar as possible for the analyzed sample and for solutions used for construction of the calibration curve. Because of its sensitivity DPP is currently the most frequently used variation of polarographic methods for analysis. There are some limitations for the use of DPP: (a) The $I-E$ curves recorded by DPP can be affected by adsorption phenomena, but their presence is not easily recognized. (b) The theoretical treatment of $I-E$ curves is available only for a few simple types of electrode processes.

See → *differential pulse voltammetry*, → *normal pulse voltammetry*, and → *reverse pulse voltammetry*.

Refs.: [i] Heyrovský J, Kůta J (1966) *Principles of polarography*. Academic Press, New York; [ii] Meites L (1965) *Polarographic techniques*, 2nd edn. Wiley Interscience, New York; [iii] Galus Z (1994) *Fundamentals of electrochemical analysis*, 2nd edn. Ellis Horwood, New York, Polish Scientific Publisher PWN, Warsaw; [iv] Kissinger PT, Heineman WR (1984) *Laboratory techniques in electroanalytical chemistry*. Marcel Dekker, New York

PZ

Normal pulse polarography — was introduced to minimize the effect of the → *charging current* and hence to increase the sensitivity of polarographic methods of analysis. In this technique, instead of increasing the potential ramp (like in DC polarography) the voltage is applied in gradually increasing pulses, one pulse during the life of a single drop of mercury. After the pulse is applied for 40 to 60 ms, the voltage returns to the initial potential. The pulses are usually applied during the last 20 to 10% of the drop-time. To achieve application of pulses in such a way, the timing of pulses must be synchronized with the drop-time. This is most frequently achieved using an electronic control of the drop time. In this device the drop control is achieved either by mechanically knocking off the drop or by a movement of the metal block in which the capillary electrode is mounted. To minimize the charging current in this (and also in differential pulse and square wave polarography), the current is measured during the last about 20% of the duration of the pulse. To this current contribute both the faradaic (electrolytic) and the charging current. But whereas the charging current decreases from the initial value rapidly and soon reaches a very small value, the faradaic current decreases more slowly and toward the end of the drop-time reaches a nearly constant value. Thus when the cur-

rent is measured during the last part of the drop-time, it contains a very small contribution of the charging current.

The shape of the current-voltage curves recorded by this technique resembles those obtained by DC polarography. The currents reach a limiting value that is a linear function of concentration of the electroactive species: The limiting currents are additive and the half-wave potentials characterize the electroactive species qualitatively. The shape of $I-E$ curves is still affected by the charging current and limiting current can be measured for electrochemically reversible systems to somewhat lower concentrations, up to about 1×10^{-7} mol L⁻¹.

See → *differential pulse voltammetry*, → *normal pulse voltammetry*, and → *reverse pulse voltammetry*.

Refs.: [i] Heyrovský J, Kůta J (1966) *Principles of polarography*. Academic Press, New York; [ii] Bond AM (1980) *Modern polarographic methods of analytical chemistry*. Marcel Dekker, New York; [iii] Kissinger PT, Heineman WR (eds) (1996) *Laboratory techniques in electroanalytical chemistry*, 2nd edn. Marcel Dekker, New York; [iv] Galus Z (1994) *Fundamentals of electrochemical analysis*, 2nd edn. Ellis Horwood, New York, Polish Scientific Publisher PWN, Warsaw

PZ

Square-wave polarography — Commonly denotes the special case of *square-wave voltammetry* applied to a dropping mercury electrode. See → *square-wave voltammetry*.

AMB

Tast polarography (sampled current polarography) → *DC polarography* with → *current sampling* at the end of each drop life. This way the ratio of → *faradaic current* to → *charging current* is enhanced and the → *limit of detection* can be decreased.

Refs.: [i] Heyrovský J, Kůta J (1966) *Principles of polarography*. Academic Press, New York; [ii] Bond AM (1980) *Modern polarographic methods of analytical chemistry*. Marcel Dekker, New York

FS

Polarometric titration → *amperometric titration*

Polaron — Polarons are charged quasiparticles with spin 1/2. This term has been introduced by physicists as one of the possible solutions to the equations of the relevant defect model of solids in order to describe an electron in a dielectric polarizing its environment (electron-phonon coupling), electrically situated below the conduction band, and transported together with its polarized environment. Polarons and → *bipolarons* are the charge carriers in oxidized or reduced (doped) → *conducting polymers*. A polaron is defined as a neutral and a charged → *soliton* in the same

chain. Chemists use the terms of radical for a neutral soliton, ion for a charged soliton, and ion radical for polaron. A polaron may possess either positive charge (cation radical) or negative charge (anion radical). By help of quantum chemical calculations information can be obtained regarding the bond length alternation, the extent of localization of the charge, density of states at the \rightarrow Fermi level, and the conduction mechanism can be explained. At high charging (doping) level, i.e., with increasing polaron concentration, polarons interact resulting in the formation of bipolarons (spinless dications) [i–iii]. (See also \rightarrow charge transport, \rightarrow conduction band, \rightarrow charge carrier, \rightarrow electronic defects.)

Refs.: [i] Chance RR, Boundreaux DS, Brédas J-L, Silbey R (1986) In: Skotheim TA (Ed) *Handbook of conducting polymers*, vol. 2. Marcel Dekker, New York, p. 825; [ii] Inzelt G (1994) *Mechanism of charge transport in polymer-modified electrodes*. In: Bard AJ (ed), *Electroanalytical chemistry*, vol. 18. Marcel Dekker, New York; [iii] Lyons MEG (1994) In: Lyons MEG (ed) *Electroactive polymer electrochemistry*, part 1. Plenum, New York, p 1

P

Pole — (i) the locus of the charge in a static electric field, or (ii) the electrically isolated terminus of a conducting path. (This latter usage, though regarded as old-fashioned, still survives in technical electrochemistry, and in circuit theory.) The inadequacy of the word in connection with electrolysis was noted by \rightarrow Faraday, and, after conferring with \rightarrow Whewell, he adopted the word \rightarrow electrode [i].

Ref.: [i] Faraday M (1834) Letter to William Whewell, 24 April 1834. In: Frank AJL James (ed) (1993) *The correspondence of Michael Faraday*, vol. 2. p 176

FS, GI, SF

Polyacetylene — An organic polymer that results from the polymerization of acetylene, characterized by a backbone comprised of long chains of alternating single and double carbon-carbon bonds. Polyacetylene is the simplest member of the family of electronically \rightarrow conducting polymers. The neutral polymer is a silvery-black, rigid compound possessing low electronic conductivity. Partial oxidation of polyacetylene, which is called in the conducting polymers field jargon \rightarrow doping (p -doping, for oxidation) with oxidants, like AsF_5 and halogens results in a dramatic increase in electronic conductivity, by up to more than 11 orders of magnitude. Crystalline polyacetylene films are synthesized by the “Shirakawa technique”, in the presence of Ziegler catalysts. Polyacetylene exists in *cis* and *trans* forms:

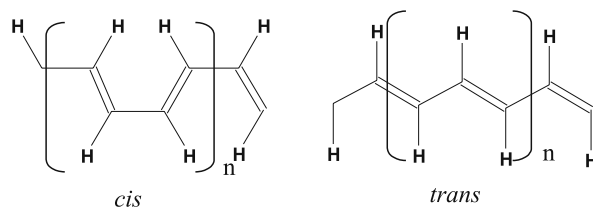

Polyacetylene — Figure

Like many other organic conducting polymers, polyacetylene is electrochemically active, attracting a great deal of interest both from the scientific and the applied point of view. In the year 2000 the chemistry Nobel Prize was granted to A. J. Heeger, H. Shirakawa, and A. G. MacDiarmid for their work on polyacetylene and the nature of conducting polymers.

Refs.: [i] Chiang CK, Fincher Jr CR, Park YW, Heeger AJ, Shirakawa H, Louis EJ, Gau SC, MacDiarmid AG (1977) *Phys Rev Lett* 39:1098; [ii] Ito T, Shirakawa H, Ikeda S (1974) *J Polym Sci Polym Chem* 12(1):11; [iii] Shirakawa H (1998) *Synthesis of polyacetylene*. In: Skotheim TA, Elsenbaumer RL, Reynolds JR (eds) *Handbook of conducting polymers*, 2nd edn. Marcel Dekker, New York, pp 197–206

YG

Polyamines \rightarrow conducting polymers

Polyampholyte — A polyampholyte is a polymeric \rightarrow ampholyte, i.e., a macromolecular (polymeric) substance having both anionic and cationic groups attached to the molecule.

Ref.: [i] Hess M, Jones RG, Kahovec J et al. (2006) *Pure Appl Chem* 78:2067

RH

Polyaniline — Beside \rightarrow polypyrroles and \rightarrow polythiophenes, polyanilines represent an important class of conjugated conducting polymers. Polyaniline is not intrinsically conductive. Its \rightarrow conductivity results from so-called \rightarrow doping via protonation and partial oxidation. Polyaniline exists in three oxidation and several protonation states (leucoemeraldine, protoemeraldine, emeraldine, nigraniline, pernigraniline – with leucoemeraldine being the fully reduced and pernigraniline the fully oxidized form). The synthesis of polyaniline is achieved from the monomer, aniline, via chemical or electrochemical oxidative polymerization (\rightarrow electropolymerization). The chemical polymerization is usually performed with ammonium peroxodisulfate, dichromate, or Fe(III) as the oxidants. Intrinsically conductive (self-doped) polyanilines are generally synthe-

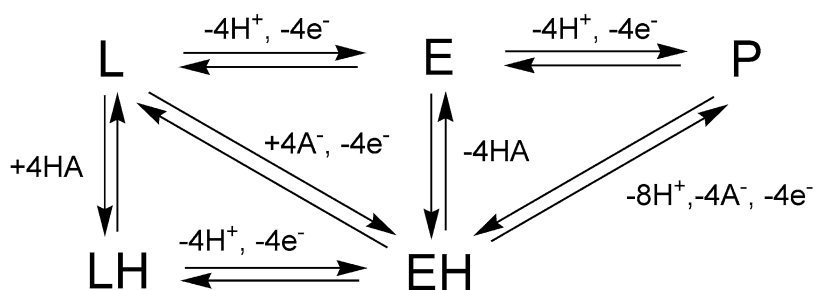
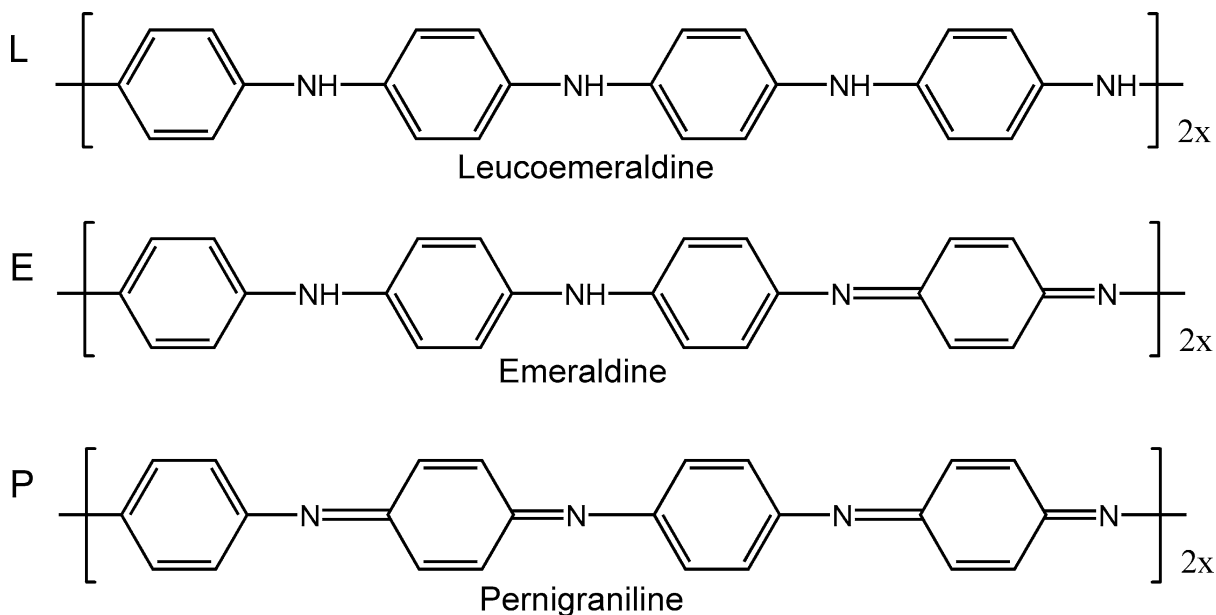

Polyaniline — Figure. Oxidation and protonation states of polyaniline

sized from substituted anilines (e.g., anthranilic acid, aminobenzenesulfonic acid) [i–v].

Electrochemical applications of polyanilines comprise \rightarrow *electrochromic devices*, \rightarrow *electrochemical sensors*, and *bioelectrochemical devices* (\rightarrow *biosensors*, \rightarrow *biofuel cells*).

Refs.: [i] MacDiarmid AG (2001) *Angew Chem* 113:2649; [ii] Nalwa HS (ed) (1997) *Handbook of organic conductive molecules and polymers. Conductive polymers: synthesis and electrical properties*, vol. 2. Wiley, Chichester; [iii] Diaz AF, Logan JA (1980) *J Electroanal Chem* 111:111; [iiii] Inzelt G, Pineri M, Schultze JW, Vorotyntsev MA (2000) *Electrochim Acta* 45:2403; [iv] Stejkal J, Gilbert RG (2002) *Pure Appl Chem* 74:857; [v] Inzelt G (2008) *Conducting polymers. A new era in electrochemistry*. In: Scholz F (ed) *Monographs in Electrochemistry*. Springer, Berlin

US

Polycarbazole \rightarrow *conducting polymers*

Polyelectrolyte membrane — A polymer can be prepared or modified resulting in functional groups being covalently attached to the polymer backbone. When these groups can dissociate like an electrolyte, a fixed ion-like part will remain attached to the backbone whereas the other part becomes mobile. In case of acidic functional groups (e.g., carbonic acids, sulfonic acids) the acid anion remains, in case of basic groups (e.g., amine groups) a cationic group remains. These polymers behave like electrolytes. With respect to the mobile ions the polymers are also called ion exchanger, in the former case cation exchanger, in the latter case anion exchanger. Polyelectrolytes can be employed as electrolytes, in electrochemical cells. Because the distance between the electrodes of a cell (\rightarrow *battery*, \rightarrow *fuel cell*, \rightarrow *electrolyzer*) should be small and because any potential drop across the electrolyte results in

voltage losses and production of heat, the polyelectrolyte should be made as thin as possible. Therefore, membrane-shaped polymer electrolytes are used.

RH

Polyelectrolytes — Polyelectrolytes are macromolecules having many ionizable groups [i, ii]. A large group of polyelectrolytes can be dissolved in appropriate solvents, e.g., in water. Other polyelectrolytes exist as swollen gels or membranes (\rightarrow *ion-exchange membrane*, \rightarrow *Donnan potential*). Most of the biopolymers, e.g., proteins, polypeptides, DNA, belong to the latter group. Polyelectrolytes can dissociate into polyvalent macroions (polyions) and a large number of small ions of opposite charge (\rightarrow *counter ions*). The high charge of the macroion produces a strong electric field which attracts the counter ions. The effect of interactions among ionized groups, counter ions, and solvent molecules is amplified by the high charge density of the polyions. A small difference in the interactions may have a great influence on the properties of polyelectrolytes. Therefore, polyelectrolytes are most sensitive to structural and environmental changes.

The \rightarrow *activity coefficient* of counter ions is very low even at low concentrations of polyions, and the \rightarrow *dielectric* \rightarrow *permittivity* of these systems is large. With an increase of the number of charges on the macroion, the electric field becomes strong and more counter ions are retained in the volume of the macroion. This phenomenon is called counter ion condensation.

There are completely dissociated polyelectrolytes, usually those containing $-\text{SO}_3\text{H}$ groups (e.g., polyvinylsulfonic acid), and also weak electrolytes having $-\text{COOH}$ groups (e.g., polyacrylic acid). There are also several polybases, e.g., those containing pyridinium groups. Copolymers are also very important, most of the biological macromolecules, e.g., proteins containing various L-amino acids, belonging to this group. They may have both positive and negative charges on the chains (side chains) (see \rightarrow *polyampholytes*).

The properties of polyelectrolytes are essentially determined by the functional groups and factors like, e.g., stereoregularity, extent of crosslinks, etc. Occasionally electrochemistry offers a unique opportunity to create a polyelectrolyte from an originally neutral polymer by oxidation or reduction (see \rightarrow *polymer-modified electrodes*).

The conformation of the macroion strongly depends on the extent of dissociation and the added amount of small ions as well as on the temperature. A macroion having a flexible linear chain may show random coil, rod,

or helical conformations. For instance, polyacrylic acid takes a spherical random coil at low pH. With increasing pH, the polyion extends, and eventually becomes rod-like. It causes a large change in the properties of the solution, e.g., in its viscosity.

The electrical effect of the highly charged macroion is screened by addition of simple electrolytes of high concentrations. This causes conformational changes, and a decrease of the repulsive forces between two polyions may eventually lead to a salting-out effect (see \rightarrow *DLVO theory*). When a polyacid is partially neutralized by addition of a base, the pH of the solution can be calculated as follows (titration curve)

$$\text{pH} = \text{p}K + m \log \alpha / (1 - \alpha) \quad (1)$$

where α is the degree of neutralization, $\text{p}K$ is the negative logarithm of the dissociation constant, and m is a constant larger than unity. The value of $(m-1)$ gives the magnitude of the effect of interaction among the charged groups ($m = 1$ for simple weak acids). It follows from the fact that a polyelectrolyte can be characterized by a series of dissociation constants since the free energy change differs for subsequent dissociation steps.

In polyelectrolyte gels the variation of pH or salt concentration (c_s) causes a swelling or shrinkage. Therefore, in this case chemical energy is transformed to mechanical work (artificial muscles). An increase of c_s (or a decrease of temperature) makes the gel shrink. Usually, the shrinking process occurs smoothly, but under certain conditions a tiny addition of salt leads to the collapse of the gel [iii, iv]. Hydration of macroions also plays an important role, e.g., in the case of proton-conductive polymers, such as \rightarrow *Nafion*, which are applied in \rightarrow *fuel cells*, \rightarrow *chlor-alkali electrolysis*, effluent treatment, etc. [v]. Polyelectrolytes have to be distinguished from the solid polymer electrolytes [vi] (\rightarrow *polymer electrolytes*) inasmuch as the latter usually contain an undissociable polymer and dissolved small electrolytes.

Refs.: [i] Oosawa F (1971) *Polyelectrolytes*. Marcel Dekker, New York; [ii] Rice SA, Nagasawa M, Moravetz H (1961) *Polyelectrolyte solutions*. *Molecular Biol Int Ser*, vol. 2. Academic Press, London; [iii] Rydzewski R (1990) *Continuum Mech Therm* 2:77; [iv] Inzelt G (1994) *Mechanism of charge transport in polymer-modified electrodes*. In: Bard AJ (ed) *Electroanalytical chemistry*, vol. 18. Marcel Dekker, New York, pp 90–241; [v] Inzelt G, Pineri M, Schultze JW, Vorotyntsev MA (2000) *Electrochim Acta* 45:2403

GI

Poly(ethylene oxide) (PEO) \rightarrow *polymer electrolytes*

Polymer electrolytes — Polymer electrolytes are materials that are based on structures usually possessing

a backbone on which charged species of one charge are immobilized in some way, whilst the counter ions are free to diffuse through the polymer conferring electrical conductivity. Early versions of such materials had very low conductivity and were designed for use with electrochemical sensors. They played much the same role as the glass in \rightarrow *glass electrodes*; with modern very high \rightarrow *impedance* voltmeters a stable \rightarrow *potential* difference proportional to the difference in concentration of ions across the \rightarrow *membrane* could be measured. A good example is the calcium-ion electrode in which the calcium salt of didecylphosphoric acid as a specific chelating agent in di-octylphenylphosphonate is stabilized by incorporation into a porous polymeric matrix of PVC or silicone rubber. Such systems are not capable of sustaining any finite current density and the need for ionically conducting membranes in the chlor-alkali industry to separate the anolyte and catholyte and allow the removal of NaOH led to the development of polymeric perfluorosulfonic acid (PFSA) derivatives commonly referred to under the trade name \rightarrow *Nafion*[®], which was the first to be marketed. The basic chemical structures of two different formulations are shown in Fig. 1 and the actual transport mechanism in the aquated membrane is shown in Fig. 2.

The main disadvantage of Nafion is that the inverse micelles in the structure must contain water if the polymer is to conduct protons or sodium ions, and dehydration of the membrane at higher temperatures leads to failure. A second disadvantage, particularly serious in \rightarrow *direct methanol fuel cells*, is that Nafion-type membranes tend to be permeable to the methanol, giving rise to major problems. Substantial effort has recently been put into fabricating higher temperature systems, especially for use in fuel cells. The main approaches have been: to form a composite between the PFSA and

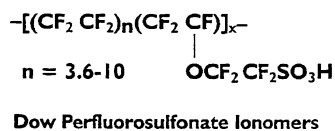
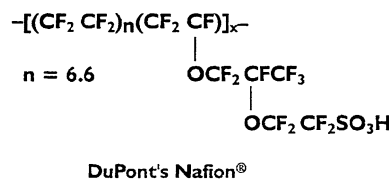

Polymer electrolytes — Figure 1

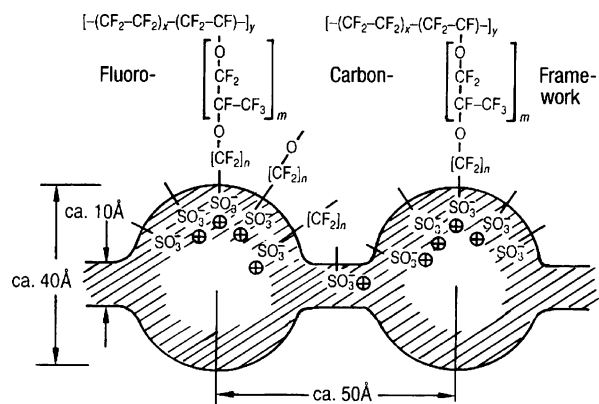

Polymer electrolytes — Figure 2

a lower volatility source of protons, such as phosphoric acid, or with mixed hygroscopic oxides such as SiO_2 and TiO_2 . More recent work has concentrated on re-cast PFSA membranes containing inorganic materials known to be proton conductors in their own right, such as heteropolyacids and zirconium phosphate. Development of sulfonated polymer membranes as alternatives to PFSA has been another active area, particularly in the development of high-temperature alternatives.

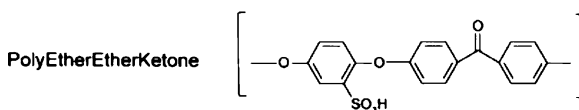
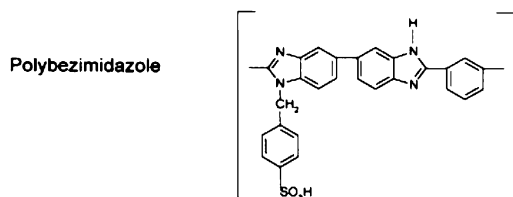
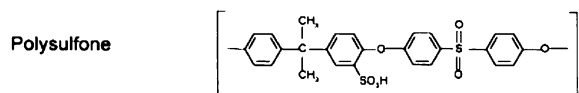
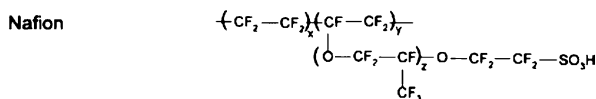

Polymer electrolytes — Figure 3

Figure 3 shows some polymer structures of other sulfonic-acid-based materials and Fig. 4 shows the conductivity of propanesulfonated polybenzimidazole, showing the strong decrease in conductivity of PFSA above $\sim 80^\circ\text{C}$ and the much more thermally stable PBI derivative.

Cationic conducting electrolytes have also been developed for Li^+ -batteries in recent years. The requirements are high conductivity, a Li^+ -transport number very close to unity, negligible electronic conductivity, high chemical and electrochemical stability, good mechanical stability, low cost and benign chemical composition. Such properties are not commonly found together, and the first successful polymers were those in which lithium salts, such as the perchlorate or tetrafluoroborate were mixed with a high-molecular-weight polymer such as poly(ethylene oxide) in a common solvent such as acetonitrile and then cast to form films be-

tween 25 and $1000\ \mu\text{m}$. The PEO forms a helical chain coordinating the Li^+ ions as shown in Fig. 5, which shows the structure of the low-temperature crystalline phase. In fact, the glass transition temperature of simple PEO phases is rather high, and branched structures are commonly employed as well as additional plasticizers or immobilized liquid solutions of Li-salts in organic solvents such as propylene carbonate. Typical conductivities are shown in Fig. 6.

Finally, anionically conducting polymeric membranes are currently being developed for use in fuel cells, particularly direct alcohol cells, where such membranes appear to expel CO_2 even at high OH^- -ion concentrations in the membrane. A simple example is shown in Fig. 7.

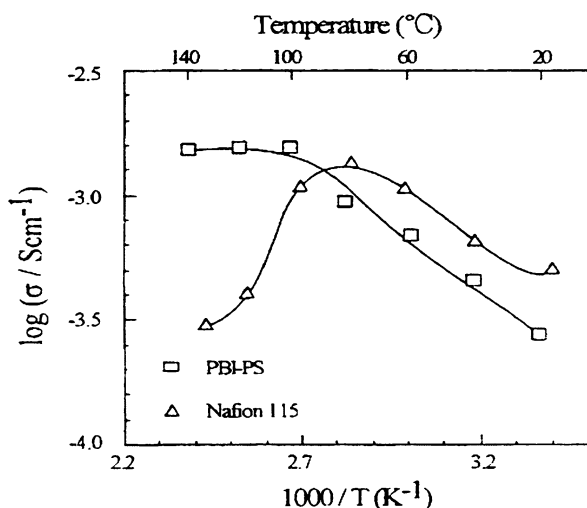

Polymer electrolytes — Figure 4

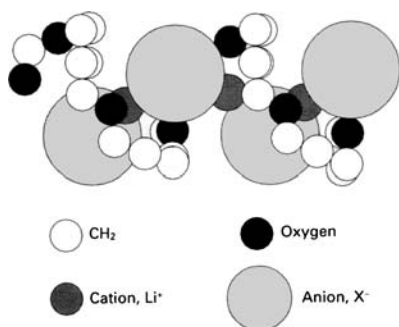

Polymer electrolytes — Figure 5

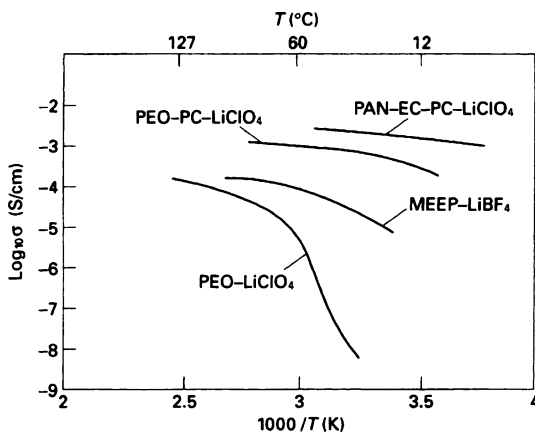

Polymer electrolytes — Figure 6

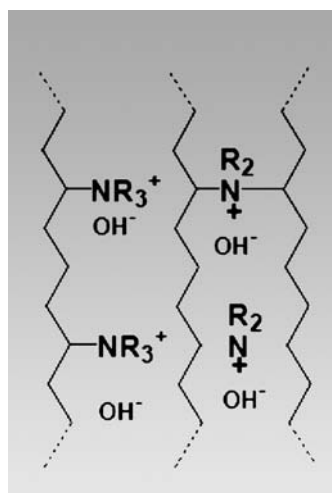

Polymer electrolytes — Figure 7

Refs.: [i] Vincent CA, Scrosati B (1997) *Modern batteries*, 2nd edn. Arnold Press, London; [ii] Li Q-F, He R-H, Jensen JO, Bjerrum NJ (2003) *Chem Mater* 15:4896; [iii] Hamann CH, Hamnett A, Vielstich W (1998) *Electrochemistry*. Wiley-VCH, Weinheim

AH

Polymer electrolyte membrane — A polymer can be prepared or modified resulting in functional groups being attached to the polymer backbone. When these groups can dissociate like an electrolyte, a fixed ion-like part will remain attached to the backbone whereas the other part becomes mobile. In case of acidic functional groups (e.g., carboxylic acids, sulfonic acids) the acid anion remains, in case of basic groups (e.g., amine groups) a cationic group remains. These polymers behave like \rightarrow *electrolytes*. With respect to the mobile ions the polymer are also called ion exchanger, in the former case cation exchanger, in the latter case anion exchanger. Polymeric electrolytes can be employed as electrolytes in electrochemical cells. Because the distance between the electrode of a cell (\rightarrow *battery*, \rightarrow *fuel cell*, \rightarrow *electrolyzer*) should be small and because any potential drop across the electrolyte results in voltage losses and production of heat, the polymeric electrolyte should be made as thin as possible, thus membrane-shaped polymer electrolytes are used.

See also \rightarrow *ions-exchange membrane*, \rightarrow *Nafion*®, \rightarrow *polyelectrolytes*, \rightarrow *polymer electrolytes*.

RH

Polymer-electrolyte-membrane fuel cell (PEMFC) — In this type of fuel cell, also known as Proton Exchange Membrane Fuel Cell, the \rightarrow *electrolyte* consists in a thin (25–175 μm) \rightarrow *proton-conducting* \rightarrow *membrane*, such as a perfluorosulfonic acid polymer, separating two Pt (or its alloys)-impregnated porous electrodes (usually carbon paper). The back sides of the electrodes are coated with hydrophobic compounds (\rightarrow *hydrophobicity*) such as PTFE forming a wet-proof coating which provides a gas \rightarrow *diffusion* path to the catalyst layer. The operating temperature of the cell is typically 80 °C.

The fuel is hydrogen (or a hydrogen-rich gas mixture) and the \rightarrow *charge carriers* are the protons that migrate through the electrolyte to combine with the \rightarrow *oxygen*, usually from air, at the cathode to form water according with the reactions:

at the \rightarrow *anode*: $\text{H}_2 \rightleftharpoons 2\text{H}^+ + 2\text{e}^-$

at the \rightarrow *cathode*: $1/2\text{O}_2 + 2\text{H}^+ + 2\text{e}^- \rightleftharpoons \text{H}_2\text{O}$

being the overall \rightarrow *cell reaction*: $1/2\text{O}_2 + \text{H}_2 \rightleftharpoons \text{H}_2\text{O}$

Due to the low operating temperature, only a few ppm (<10 ppm) of CO may be tolerated by the Pt catalyst. If a hydrocarbon such as natural gas is used as a primary fuel, reforming according to the reaction:

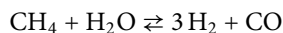

and shift of the reformat by the reaction

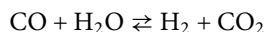

and the removal of the unconverted CO to ppm levels is required to generate the fuel for the cell. Also the sulfur compounds present in the fuel have to be removed prior to use in the cell to a concentration of <0.1 ppm.

The net electrical efficiency of a PEMFC is 40–47% and the operating temperature is not high enough to perform useful cogeneration. At low levels of Pt loading (0.4 mg cm^{-2}) a maximum \rightarrow *power density* of 1.57 W cm^{-2} was obtained at a \rightarrow *cell voltage* of 0.46 V (0.73 W cm^{-2} at 0.73 V). At high Pt loading (5 mg cm^{-2}), power density was increased by 60–70%.

Being very compact and lightweight, the PEMFCs generate more power for a given volume or weight of the units than other types of fuel cells. In addition, the low operating temperature allows a rapid start-up. These qualities and the ability to rapidly change the power output are some of the characteristics that make the PEMFC the top candidate for automotive power applications. Other advantages result from the electrolyte being a solid material, compared to a liquid, which simplifies the fuel cell manufacture and minimize the \rightarrow *corrosion* phenomena.

See also \rightarrow *fuel cells*.

Refs.: [i] Costamagna P, Srinivasan S (2001) *J Power Sources* 102:242;

[ii] Costamagna P, Srinivasan S (2001) *J Power Sources* 102:253;

[iii] Bockris JO'M, Khan SUM (1993) *Surface electrochemistry*. Plenum Press, New York

JC

Polymer-modified electrodes — A polymer-modified electrode or polymer film electrode can be defined as an \rightarrow *electrode* in which at least three phases are contacted successively in such a way that between a first-order \rightarrow *conductor* (usually a metal) and a second-order conductor (usually an \rightarrow *electrolyte* solution) is an electrochemically active polymer layer: this polymer is, in general, a mixed (electronic and ionic) conductor [i]. A transfer of electrons to solution species may occur at the two \rightarrow *interfaces* (phase boundaries) and as a mediated reaction inside the film. The essential characteristic of polymer-modified electrodes is the mechanism of the

→ *charge transport*. The electrons transferred to the polymer at the metal/polymer interface can be transported through the surface layer by electron-exchange reaction (→ *electron hopping*) in the case of redox polymers or can move through the conjugated systems of electronically → *conducting polymers*.

Redox polymers contain either covalently attached redox sites, or redox-active ions that are held by electrostatic binding. The redox sites are oxidized or reduced during the electrochemical transformations. The necessary approach of the redox sites for the electron hopping is made possible by the chain and segmental motion of the polymer.

The electronically conducting polymers consist of polyconjugated, polyaromatic, or polyheterocyclic macromolecules and have the unusual property of possessing high electrical conductivity in partial oxidized or reduced (“doped”) state. Even assuming intrachain electron transport, it is likely that electron hopping ensures the interchain electron transport. In the case of both the redox and conducting polymers charge is also carried by the motion of electroinactive ions during electrolysis, because it is necessarily coupled to the transfer of electrons in order to preserve → *electroneutrality* within the film.

Polymer film electrodes are prepared either by evaporation technique or by → *electropolymerization*. Redox polymers that are usually synthesized chemically are dissolved in a suitable solvent, placed as a droplet on the surface of a metal (or dip-coating, spin-coating techniques are applied) and the solvent is subsequently left to evaporate. The electrode can be used in other solvents in which the polymer is insoluble. Conducting polymer layers are usually developed by electropolymerization directly on the surface of the metal.

Since the appearance of the redox [ii, iii] and conducting [iv] polymer-modified electrodes much effort has been made concerning the development and characterization of electrodes modified with electroactive polymeric materials, as well as their application in various fields such as → *sensors*, actuators, ion exchangers, → *batteries*, → *supercapacitors*, → *photovoltaic devices*, → *corrosion protection*, → *electrocatalysis*, → *electrochromic devices*, electroluminescent devices (→ *electroluminescence*) [i, v–viii]. See also → *electrochemically stimulated conformational relaxation (ESCR) model*, and → *surface-modified electrodes*.

Refs.: [i] Inzelt G (1994) *Mechanism of charge transport in polymer-modified electrodes*. In: Bard AJ (ed) *Electroanalytical chemistry*, vol. 18. Marcel Dekker, New York, pp 89–241; [ii] Merz A, Bard AJ (1978) *J Am Chem Soc* 100:3222; [iii] Miller LL, Van De Mark MR (1978) *J Am Chem*

Soc 100:3223; [iv] Diaz AF, Kanazawa KK, Gardini GP (1979) *J Chem Soc Chem Commun* 635; [v] Murray RW (1984) *Chemically modified electrodes*. In: Bard AJ (ed) *Electroanalytical chemistry*, vol. 13. Marcel Dekker, New York, pp 191–368; [vi] Murray RW (ed) (1992) *Molecular design of electrode surfaces*. In: Weissberger A, Sanders WH, *Techniques of chemistry*, vol. 22. Wiley, New York; [vii] Lyons MEG (ed) (1994, 1996) *Electroactive polymer electrochemistry, parts 1 and 2*. Plenum Press, New York; [viii] Inzelt G, Pineri M, Schultze JW, Vorotyntsev MA (2000) *Electrochim Acta* 45:2403

GI

Polyoxometalates — Polyoxometalates are polymeric (polynuclear) oxoanions of certain transition metal elements (e.g., molybdenum, tungsten, and vanadium). When during the condensation process which leads to the formation of polyanions, oxo-anionic hetero-groups of *p*-block atoms (e.g., tetrahedral PO_4^{3-} , SiO_4^{4-} , BO_3^{3-} or AsO_4^{3-} ions) are incorporated into the structures, heteropolyanions are formed. Otherwise isopolyanions are formed. Among the heteropolyanions, Keggin-type dodecatungstate or dodecamolybdate structures are best known, such as tungstosilicic or silicotungstic ($\text{SiW}_{12}\text{O}_{40}^{4-}$), phosphotungstic ($\text{PW}_{12}\text{O}_{40}^{3-}$) and phosphomolybdic ($\text{PMo}_{12}\text{O}_{40}^{3-}$) anions. When the condensation involves acids of *p*-block atoms (such as H_3PO_4 , H_4SiO_4), rather than their salts, highly hydrated single crystals of heteropolyacids can be grown. Their identity can be described in terms of the rigid primary heteropolymetalate structure surrounded by the secondary pseudoliquid structure of the hydration water molecules and exceptionally mobile hydrated → *protons*.

Polyoxometalates can undergo fast and reversible multi-electron redox reactions involving → *electron transfer* between mixed-valence transition metal sites (e.g., $\text{W}^{\text{VI,V}}$ or $\text{Mo}^{\text{VI,V}}$) according to the electron self-exchange or → *electron hopping* mechanism. This model is operative during partial electroreduction, i.e., injection of up to four electrons to a Keggin-type heteropoly structure of molybdenum or tungsten. Further reduction of heteropolytungstate or molybdate is irreversible and leads to the formation of so-called heteropolybrown species in which such distinct ionic sites as W^{VI} and W^{IV} or Mo^{VI} and Mo^{IV} can coexist. The high “ionic budget” of structural protons in polyoxometalate single crystals (capable of providing electroneutrality during redox transitions) permits their electroanalytical investigation in the absence of external liquid electrolyte phase, i.e., using so-called microelectrode-based solid-state voltammetry (see → *solid-state electrochemistry*).

Because of its chemical and physical properties, polyoxometalates are widely used in many areas of science

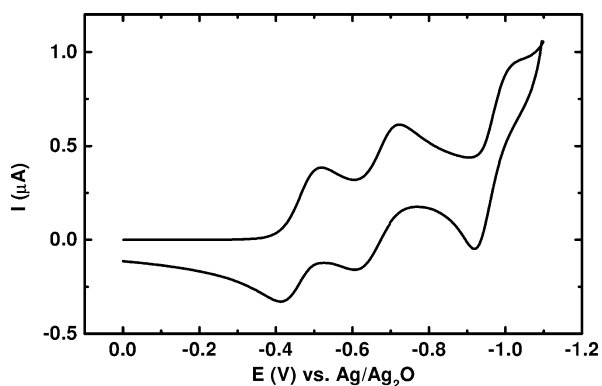

Polyoxometalates — Figure. Cyclic voltammogram of the phosphotungstic acid single crystal recorded (at 5 Vs^{-1} scan rate) in the absence of contact with liquid electrolyte phase using gold microdisk (diameter, $10 \mu\text{m}$) working electrode. The redox processes involve injections of 1, 1, and 2 electrons according to general equation: $\text{PW}_{12}\text{O}_{40}^{3-} + n \text{e}^{-} + n \text{H}^{+} \rightleftharpoons \text{H}_n\text{PW}_{12}\text{O}_{40}^{3-n}$

and technology including catalysis and electrocatalysis, charge-storage and electrochromic devices, photoelectrochemistry, \rightarrow corrosion protection, amperometric \rightarrow gas sensors, and in medicine, e.g., to produce antiviral drugs.

Refs.: [i] Hill CL (1998) *Chem Rev* 98:1; [ii] Kulesza PJ, Karwowska B (1996) *J Electroanal Chem* 401:201; [iii] Himeno S, Takamoto M, Ueda T (1999) *J Electroanal Chem* 465:129; [iv] Himeno S, Takamoto M, Ueda T (2000) *J Electroanal Chem* 485:49; [v] Nakamura O, Kodama T, Ogino I, Miyake Y (1979) *Chem Letters* 17; [vi] Nakamura O, Ogino I, Kodama T (1981) *Solid State Ionics* 3-4:347; [vii] England WA et al (1980) *Solid State Ionics* 1:231; [viii] Clark CJ, Hall D (1976) *Acta Cryst B* 32:1545; [ix] Misono M et al (1987) *J Am Chem Soc* 109:5535; [x] Kreuer KD, Hampele M, Dolde K, Rabenau A (1988) *Solid State Ionics* 28-30:589; [xi] Kulesza PJ, Karwowska B, Malik MA (1998) *Colloids Surf A* 134:173; [xii] Kulesza PJ, Faulkner LR (1993) *J Am Chem Soc* 115:11878; [xiii] Clearfield A (1988) *Chem Rev* 88:125; [xiv] Andrieux CP, Saveant JM (1980) *J Electroanal Chem* 111:377; [xv] Pope MT, Mueller A (2003) *Angew Chem Int Ed* 30:34; [xvi] Keita B, Nadjo L (2006) *Electrochemistry of isopoly and heteropoly oxometalates*. In: Bard AJ, Stratmann M, Scholz F, Pickett CJ (ed) *Inorganic chemistry. Encyclopedia of Electrochemistry*, vol. 7b. Wiley-VCH, Weinheim, pp 607

PK, AL

Poly(paraphenylene), PPP — is a conjugated polymer that can be electrochemically and chemically synthesized. The repeating unit in PPP is shown below. The polymer is insoluble in all organic or mineral solvents, and the neutral form environmentally stable. The \rightarrow electrosynthesis gives adherent films. The polymer can be *n*- and *p*-doped (\rightarrow doping), it has a nondegenerate ground state, and it shows electroluminescence. The

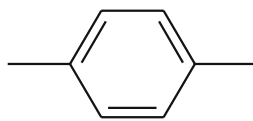

Poly(paraphenylene), PPP — Figure

\rightarrow conductivity varies with the way of synthesis and doping between 10^{-7} – 100 Scm^{-1} . PPP has been applied in light-emitting diodes and in Schottky-type devices (see also \rightarrow Schottky, \rightarrow Schottky barrier, \rightarrow Schottky contact). See also \rightarrow conducting polymers.

Refs.: [i] Lacaze PC, Aeiach S, Lacroix JC (1997) *Poly(p-phenylenes): preparation techniques and properties*. In: Nalwa HS (ed) *Handbook of organic conductive molecules and polymers*. Wiley, Chichester; [ii] Kvarnström C, Ivaska A (1997) *Characterization and applications of poly(p-phenylene) and poly(p-phenylene vinylene)*. In: Nalwa HS (ed) *Handbook of organic conductive molecules and polymers*. Wiley, Chichester

CK

Poly(paraphenylene vinylene), PPV — is a conjugated polymer that can be electrochemically (by electroreduction) and chemically synthesized, e.g., from sulfonated or halogenated *p*-xylene. The repeating unit is shown below. The polymer can be *n*- and *p*-doped (\rightarrow doping). The polymer has a nondegenerate ground state, nonlinear-optical properties, and has bright yellow fluorescence. The optical band gap is approx. 2.6 eV. PPV derivatives have been applied as active layer in LED structures and in \rightarrow photovoltaic devices. See also \rightarrow conducting polymers.

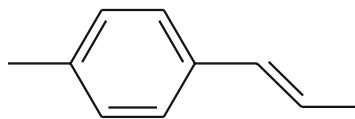

Poly(paraphenylene vinylene), PPV — Figure

Refs.: [i] Gruber J, Li RWC, Hümmelgen IA (2001) *Synthesis, properties and applications of poly(paraphenylene vinylene)*. In: Nalwa HS (ed) *Handbook of advanced electronic and photonic materials and devices*. Academic Press, San Diego; [ii] Kvarnström C, Ivaska A (1997) *Characterization and applications of poly(p-phenylene) and poly(p-phenylene vinylene)*. In: Nalwa HS (ed) *Handbook of organic conductive molecules and polymers*. Wiley, Chichester

CK

Polypyrrole, PPy — is a conducting polymer with the repeating unit of a nitrogen heterocycle (see structure be-

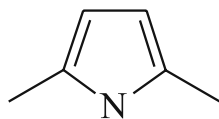

Polypyrrole, PPy — Figure

low). The polymer can be synthesized chemically or electrochemically. The \rightarrow *electrosynthesis* is possible in both aqueous and organic solutions. The oxidation potential of the polymer is low enough to allow charge transfer interaction with oxygen. The *p*-doped PPy-form (\rightarrow *doping*) is stable towards oxygen. PPy has been suggested as matrix for a variety of chemical \rightarrow *sensors* and \rightarrow *biosensors* and as carrier of catalytically active materials. Functionalization and substitution in *N*-position of the pyrrole unit results in strongly modified properties (i.e., solubility, \rightarrow *conductivity*, ion recognition, etc.) of the polymer. See also \rightarrow *conducting polymers*.

Refs.: [i] Rodriguez J, Grande H-J, Otero TF (1997) *Polypyrroles: from basic research to technological applications*. In: Nalwa HS (ed) *Handbook of organic conductive molecules and polymers*. Wiley, Chichester; [ii] Wallace GG, Spinks GM, Kane-Maguire LAP, Teasdale, PR (2002) *Conductive electroactive polymers: intelligent materials systems*. CRC Press, Boca Raton

CK

Poly(thiophene) — is a conducting polymer with repeating unit consisting of a sulfur hetero five ring (see Figure (1)). Poly(thiophene) is environmentally stable in its neutral state and highly resistant to heat. The \rightarrow *electropolymerization* from nonaqueous solutions proceeds at a higher anodic potentials than that of pyrrole. A range of functional groups has been introduced to modify the chemical properties. Substitution at the β -carbon position by different electron-donating or -withdrawing groups effects the polymerization potential of the monomer. Substitution of active groups, e.g., amino acids, introduces molecular recognition properties in \rightarrow *biosensors*. Alkylsubstitution (see Figure (2)) in 3-position of the heteroring makes the polymer soluble in nonpolar organic solvents and enables solution casting. Substitution of sulfonated groups makes the polymer water soluble. Substitution in both 3- and 4-positions like in the monomer 3,4-ethylenedioxythiophene, EDOT (see Figure (3)), excludes crosslinking effects during polymerization. In presence of surfactants like sodium dodecylsulfonate, EDOT can be polymerized from aqueous solutions. Composite material consisting of poly(3,4-ethylenedioxythiophene)-poly(styrene sulfonate) (PEDOT-PSS)

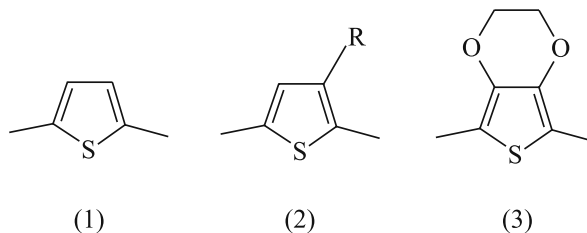

Poly(thiophene) — Figure

(Baytron P) has been extensively used as antistatic coating. See also \rightarrow *conducting polymers*.

Refs.: [i] Inzelt G (2008) *Conducting polymers. A new era in electrochemistry*. In: Scholz F (ed) *Monographs in Electrochemistry*. Springer, Berlin; [ii] Schopf G, Koßmehl G (1997) *Adv Polym Sci* 129:1; [iii] Roncali J (1997) *Chem Rev* 97:173

CK

Population mean (μ) — The \rightarrow *mean* of a large set of data [i].

Ref.: [i] Skoog D, West D, Holler F (1996) *Fundamentals of analytical chemistry*. Saunders College Publishing, New York

FG

Porous electrodes — Porous \rightarrow *electrodes* possess an internal pore system expanding into the solid. As a result, there is an internal surface area which comprises the wall of the pores, and it is orders of magnitudes larger than the outer or geometric surface area of the solid body. Since \rightarrow *electrode processes* occur at the \rightarrow *interface*, the primary motivation for using porous electrodes is the enlargement of the surface area per unit volume of the solid. From among several tens of types of porous solids (mainly solid oxides), the most significant porous electrodes are carbon and graphite.

The unit 'electrode activity per unit of weight or volume' (related to the energy density of the electrical \rightarrow *double layer* (EDL) \rightarrow *capacitors* or the \rightarrow *current density* of a \rightarrow *fuel cell* electrode) is estimated depending on the particular application. In the case of volume-based optimization, the goal is to attain as large a surface area per unit volume as possible. This requires progressively greater subdivision of the solid, resulting in smaller pores. Obviously, a lower limit is set to the size of the pores: as the pore size becomes closer to that of the reacting molecule, the electrode \rightarrow *kinetics* becomes progressively slower and, when the pore size becomes smaller than the size of the reacting molecule, no electrode process can take place. This pore size range, which is about that of a single molecule, is termed "molecular sieving range" and is the smallest that is electrochemi-

cally interesting. It is useful for devices of very slow electrode rates such as the EDL capacitor for memory support. In these devices, the current density is just a fraction of a mA cm^{-2} . The largest “pore” size is infinity, namely that of a flat electrode. An example for its application is the catalytically-activated flat titanium anode plates in \rightarrow *chlor-alkali production*. The currents in this case are several hundreds of mA cm^{-2} . Examples for intermediate (or meso, see below) pore application are the carbon electrodes that support catalyst particles, such as platinum, e.g., in \rightarrow *phosphoric acid fuel cells*. Here the catalyst particles are about 1–2 nm in size, while the host is a \rightarrow *carbon black powder* which forms clusters separated by vacancies of several nm. In summary, the more finely divided is the pore system, the larger is the electrode capacity, but the slower is the process kinetics.

A nomenclature was adopted internationally by IUPAC. Thus, micropore dimensions are smaller than 2 nm, mesopores fall between 2–50 nm, and macropores are above 50 nm.

To this we may add the molecular sieve porosity which falls below 0.6 nm.

Molecular sieving and microporosity: Carbons (\rightarrow *carbon, electrode material*) are the product of pyrolysis of polymers (synthetic or natural) under inert atmosphere. If the polymers are low in C–H bonds, they are likely to be nonmelting in the course of pyrolysis. In this case there is no chance for extensive reorganization to a graphitic order. Therefore, a distorted aromatic structure is obtained, comprising chemical nonhomogeneity. By careful oxidation, the more active sites are burnt off, leading to a porous structure in the range of 0.4 to 2 nm that is adjustable by the extent of oxidation.

Mesoporosity: Nanoparticles of tin and titanium oxides can be readily prepared by the hydrolysis of their four valent compounds. These nanopowders, can be packed, with or without a binder, leading to mesoporous oxide electrodes. Mesoporous oxides, especially those of silica and aluminum, may serve as templates for depositing nonmelting polymers that can be carbonized and chemically treated (aqueous HCl, HF, or alkali) to dissolve the templating material, thus obtaining pure mesoporous carbons (may also be activated to create microporosity). Templated (see \rightarrow *template synthesis*) mesoporous carbons have recently become very popular, in regard to nanoscience and technology. The methods that are based on templating are attractive, since accurately patterned powders or massive solids can be obtained.

Powder packaging of carbon blacks creates clusters of particles. The spaces between the clusters yield mesoporosity. Packed carbon blacks provide a fair multipore-

size distribution that is very useful in both EDLC, and in porous anodes and cathodes in batteries. Although a packed bed of carbon blacks without a binder provides stable structure, the use of binders is not rare since the electrodes can be fabricated into flexible sheets that can be rolled or stacked to the required configuration.

Air diffusion electrodes: In fuel cells and in air-breathing batteries, a mesoporous carbon electrode is made up of two layers: an outer layer composed of carbon powder and a hydrophobic (nonwetable) binder, typically PTFE. This enables the access of gas to the inner layer, where the binder is selected to be both a hydrophilic (wetable) and an ion-conducting ionomer, to support (rather than impair if the binder was nonconducting) the ionic conductivity of the porous electrode. The catalyst particles are dispersed in-between the carbon particles. Thus, a very tortuous interface between the two layers is formed. The reacting gas approaches this interface, forming three phase points of contact providing a high active surface area. See also \rightarrow *air electrode*.

Characterization: Surface area of porous electrodes can be calculated from gas \rightarrow *adsorption*, using appropriate models (e.g., the commonly used B.E.T model). The electrode structure can be analyzed by X-ray and neutron diffraction. The pore morphology can be analyzed by electron microscopy (SEM, TEM, HRTEM, and HRSEM).

Refs.: [i] Eliad L, Salitra G, Soffer A, Aurbach D (2001) *J Phys Chem B* 105:6880; [ii] Bommaraju TV, Orosz PJ, Brine electrolysis. In: *Electrochemistry encyclopedia* (<http://electrochem.cwru.edu/ed/encycl/>); [iii] Sing KSW, Everett D, Haul RAW, Moscou L, Pierotti RA, Rouquerol J, Siemieniowska T (1985) *Pure Appl Chem* 57(4):603; [iv] Koresh JE, Soffer A (1983) *Sep Sci Technol* 18(8):723; [v] Álvarez S, Blanco-López MC, Miranda-Ordieres AJ, Fuertes AB, Centeno TA (2005) *Carbon* 43:866; [vi] Carrette L, Friedrich KA, Stimming U (2001) *Fuel Cells 1:1*; [vii] Adamson AW (1976) *Physical chemistry of surfaces*, 3rd edn. Wiley, New York; [viii] Jagiello J, Thommes M (2004) *Carbon* 42:1227

DA, AS

Porphyrin — The porphyrins are a group of highly colored, naturally occurring pigments containing a porphine nucleus (Figure) with substituents at the eight β -positions (2,3,7,8,12,13,17,18) of the pyrroles, and/or the four meso-positions (5,10,15,20) between the pyrrole rings [i]. The natural pigments are metal chelate complexes of the porphyrins. Electrochemical studies of porphyrins reveal characteristic reversible multi-step redox chemistry, with two reversible successive ligand-centered one-electron transitions on both oxidation and reduction [ii]. The electrochemical behavior and \rightarrow *re-*

dox potentials for a given metalloporphyrin will depend on the solution and experimental factors, as well as upon the type and oxidation state of the metal ion, the type and planarity of the macrocycle and the specific set of axial ligands [iii].

Porphyrins are an important class of \rightarrow *electron-transfer* ligands. \rightarrow *Photosynthesis* is primarily driven by chromophores (light-harvesting antenna and reaction centers) which consist of special assemblies of porphyrins. Porphyrins have been intensively studied for their possible applications, including their use as photonic materials, catalysts, photosensitizers for photodynamic therapy, receptor models in molecular recognition, and components of \rightarrow *electrochemical sensors* [v].

Phthalocyanines (Figure) are tetraazatetrabenzo derivatives of porphyrins with highly delocalized π -electron systems. The metal ion in metallophthalocyanines lies either at the center of a single phthalocyanine ligand (Pc = dianion of phthalocyanine) (Figure), or between two rings in a sandwich-type complex. Phthalocyanine complexes of transition metals usually contain only a single Pc ring while lanthanide-containing species usually form bis(phthalocyanines), where the π -systems interact strongly with each other. See \rightarrow *phthalocyanines*.

Refs.: [i] Mashiko T, Dolphin D (1987) *Porphyrins, hydroporphyrins, azaporphyrins, phthalocyanines, corroles, corrins and related macrocyclic*

des. In: Wilkinson G, Gillard RD, McCleverty JA (eds) *Comprehensive coordination chemistry* 2. Pergamon, Oxford, chap 21.1; [ii] Zanello P (2003) *Inorganic electrochemistry: theory, practice and application*. The Royal Society of Chemistry, Cambridge, pp 363–371; [iii] Kadish KM, Royal G, van Caemelbecke E, Gueletti L (2000) 59. *Metalloporphyrins in nonaqueous media: database of redox potentials*. In: Kadish KM, Smith KM, Guillard R (eds) *Database of redox potentials and binding constants. The porphyrin handbook*, vol. 9. Academic Press, New York; [iv] Leznoff CC, Lever ABP (eds) *Phthalocyanines: properties and applications* 1. Wiley, New York, vol. 1 (1989); vol. 2 (1993); vol. 3 (1993); vol. 4 (1996); [v] Kadish KM, Smith KM, Guillard R (eds), (2000) *Applications: past, present, and future. The porphyrin handbook*, vol. 6. Academic Press, New York

RJM

Positive feedback circuit — Electronic circuit incorporated in a \rightarrow *potentiostat*, which is used for the \rightarrow *IR drop* compensation. Through this circuit, a part of the voltage at the current output of a potentiostat is positively fed back to the potential input, so that the \rightarrow *IR drop* can be automatically compensated for. However, note that the positive feedback makes the system unstable and occasionally leads to oscillation. See also \rightarrow *four-electrode system*.

Ref.: [i] Britz D (1978) *J Electroanal Chem* 88:309; [ii] Roe DK (1996) *Overcoming solution resistance with stability and grace in potentiostatic circuits*. In: Kissinger PT, Heineman WR (eds) *Laboratory techniques in electroanalytical chemistry*. Marcel Dekker, New York, chap. 7

TO

Positron lifetime spectroscopy \rightarrow *radiochemical (nuclear) methods in electrochemistry*

Post-wave \rightarrow *pre-wave*

Potassium cation conductors \rightarrow *solid electrolyte*

Potassium conducting solid electrolyte \rightarrow *solid electrolyte*

Potential

Absolute potential (also called single electrode potential) — is a hypothetical *p.* of an isolated \rightarrow *electrode* without referring it to any reference electrode. Although it has long been known that only relative \rightarrow *electrode p.* can be measured experimentally, numerous attempts were undertaken to determine such a value (see in [i–x]). The problem was also formulated as a search for the hypothetical reference state determined as reckoned from the ground state of \rightarrow *electron* in vacuum (a “physical” scale of energy with the opposite sign). In

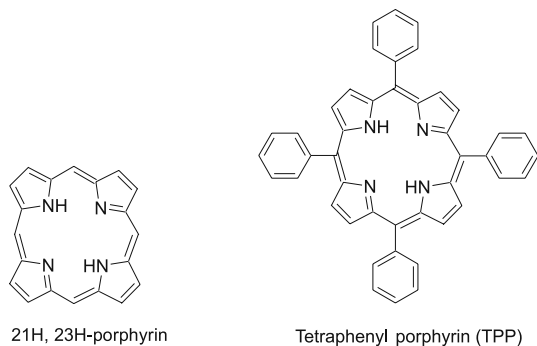

21H, 23H-porphyrin

Tetraphenyl porphyrin (TPP)

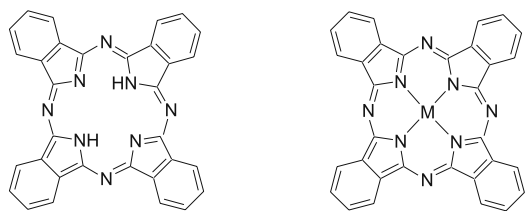

29H, 31H-phthalocyanine

A 1:1 metallo-phthalocyanine complex

Porphyrin — **Figure**. Structures of a selection of porphyrins and phthalocyanines

this connection, the requirement for the reference electrode was formulated as the absence of any additional electrochemical \rightarrow *interfaces*. Finally, these studies have transformed into a reasonable separation of the measured \rightarrow *electromotive force (emf)* for a cell, which consists of an electrode under consideration and a standard \rightarrow *reference electrode*, in order to determine two electrode potentials referred to individual interfaces (or to the separate half-reactions) by using only the experimentally measurable values. The absolute potential can not be calculated in the framework of thermodynamics without introducing certain model assumptions. One can obtain this value from \rightarrow *Volta potential difference* and \rightarrow *surface potential* values of a metal (χ^M) and a solution (χ^S):

$$\Delta_S^M \varphi = \Delta_S^M \psi - \chi^S + \chi^M .$$

For the surface potential of water various model estimates result in ca. 0.1 V. Model estimates of the surface potential of metals still remain contradictory. The scale of “absolute potentials” which was recommended in [iv], is in fact equivalent to the E_K scale (Kanevskii’s scale) [v] that was proposed in [vi, vii]:

$$E_K = - \left[\Delta G_{\text{subl}} + \Delta G_{\text{ion}} + \Delta G_{\text{hydr}}^{(\text{real})} \right] / z_i F .$$

By introducing this scale, we can separate the total emf of the cell into two quantities, for which the contributions (ΔG_{subl} , ΔG_{ion} , and $\Delta G_{\text{hydr}}^{(\text{real})}$ are the sublimation, ionization, and real hydration \rightarrow *Gibbs energies*, respectively) can be experimentally determined. For the \rightarrow *hydrogen electrode* it holds that

$$(E_K)_{\text{H}^+, \text{H}_2} = - \left[\frac{1}{2} \Delta G_{\text{diss}} + \Delta G_{\text{ion}} + \Delta G_{\text{hydr}}^{(\text{real})} \right] / F$$

and this gives the possibility to recommend the value $-4.44 (\pm 0.02)$ V for the “absolute potential” of the \rightarrow *standard hydrogen electrode* (at 298.15 K). The uncertainty of absolute potential calculation is substantially higher than the accuracy of direct potential measurements with respect to a reference electrode. Useful comments to Kanevskii’s scale can be found in [viii–x]. In the “absolute” scale, the “absolute potential” of any aqueous electrode at 298.15 K can be determined as

$$E_K = (E_K)_{\text{H}^+, \text{H}_2} + E \approx -4.44 \text{ V} + E ,$$

where E is the potential referred to the standard hydrogen electrode. The “absolute potentials” of the hydrogen electrode in a number of nonaqueous solvents are reported in [iv]. The value of E_K can be expressed

via the metal–vacuum electron \rightarrow *work function* W_e and \rightarrow *Volta potential difference* [v], e_0 is the charge of the electron:

$$E_K = W_e / e_0 + \Delta_S^M \psi .$$

The majority of electrochemical problems can be solved without using “absolute potentials”, but these quantities are of interest for the electrochemistry of \rightarrow *semiconductors* (for calibrating the energy levels of materials) and are related to a general problem of physical chemistry, the determination of \rightarrow *activity coefficients* of an individual charged species.

Refs.: [i] Pleskov VA, Ershler BV (1949) *Zh Fiz Khimii* 23:101; [ii] Reiss H, Heller A (1985) *J Phys Chem* 89:4207; [iii] Pleskov YuV (1987) *J Phys Chem* 91:1691; [iv] Trasatti S (1985) *Pure Appl Chem* 58:955; [v] Frumkin A, Damaskin B (1975) *J Electroanal Chem* 66:150; [vi] Kanevskii EA (1948) *Zh Fiz Khimii* 22:1397; [vii] Kanevskii EA (1981) *Doklady AN SSSR* 257:926; [viii] Ershler BV (1954) *Zh Fiz Khimii* 28:957; [ix] Pleskov VA (1949) *Zh Fiz Khimii* 23:104; [x] Ershler BV, Pleskov VA *Zh Fiz Khim* (1951) 25:1258; [xi] Parsons, R (1985) *The single electrode potential: Its significance and calculation*. In: Bard AJ, Parsons R, Jordan J (eds) *Standard potentials in aqueous solution*. Marcel Dekker, New York, chap 2

GT, OP

Accumulation potential — is the value of potential for accumulating a certain reagent at the electrode surface or in the electrode volume (for instance in an \rightarrow *amalgam* or when using the electroanalytical technique known as \rightarrow *stripping voltammetry*).

GT

Asymmetry potential — In case of any membrane it happens that the potential drop between the solution and either inner side of the \rightarrow *membrane* is not completely identical so that a nonzero net potential drop arises across the entire membrane. This is best known for \rightarrow *glass electrodes* and other \rightarrow *ion-selective electrodes*. The reasons of asymmetry potentials are chemical or physical differences between each side of a membrane, in particular an inhomogeneous membrane structure resulting from fabrication conditions and/or curvature. Asymmetry p. can change in the course of membrane ageing. To measure asymmetry p. one should use a symmetrical cell with identical solutions and \rightarrow *reference electrodes* on each side of the membrane.

Ref.: [i] Wiemhoefer H-D, Cammann K (1992) *Specific features of electrochemical sensors*. In: Goepel W, Hesse J, Zemel JN (eds) *Sensors – a comprehensive survey chemical and biochemical sensors*, vols. 7, 8. VCH, Weinheim, p 160

FS

Biochemical potential \rightarrow *biochemical standard potential*

Biochemical standard potential — (E') Most biochemical processes proceed at pH values that are not too far from 7, and most biochemical redox systems involve also a proton transfer, i.e., they can be written as $\text{Ox} + n\text{H}^+ + m\text{e}^- \rightleftharpoons \text{H}_n\text{Red}^{(n-m)+}$. Thus it became customary to define the potential of those redox systems at pH 7.0 as the biochemical standard potential E' . E' is related to the (chemical) \rightarrow standard potential E^\ominus as follows: $E' = E^\ominus - 0.414 \left[\text{V} \right] \frac{n}{m}$.

Ref.: [i] Rieger PH (1987) *Electrochemistry*. Prentice-Hall, London

Characteristic potential — means the potential of a certain singular point in electrochemical response that is characteristic of the particular charge-transfer process (\rightarrow charge-transfer kinetics) or interfacial phenomenon. Any characteristic p. is related to given experimental conditions (such as the temperature, the nature of the solvent, and supporting \rightarrow electrolyte and its concentration). The nature and type of characteristic p. depends on the technique that is employed. Typical characteristic potentials are the \rightarrow half-wave potential in \rightarrow polarography and the \rightarrow peak potentials in \rightarrow voltammetry, similar maximum/minimum of inflection points can be listed for other techniques.

Ref.: [i] IUPAC Recommendations (1985) *Pure Appl Chem* 57:1493

Chemical potential \rightarrow chemical potential

Deposition potential — is the required value to observe the appearance of a new phase in the course of a \rightarrow electrocrystallization process. See, \rightarrow equilibrium forms of crystals and droplets, \rightarrow nucleation and growth kinetics, \rightarrow nucleation overpotential.

Diffusion potential — $\Delta\varphi_{\text{diff}}$ is the \rightarrow Galvani potential difference at the junction of two electrolytes resulting from the difference in the rates of transport of various ions and/or differences of their activities across the junction region. For the case of junction of two electrolyte solutions it is called \rightarrow liquid junction potential (see also \rightarrow liquid junction, and \rightarrow flowing junction). This quantity can not be measured. Diffusion potential can be estimated by adopting a model approach to the concentrational distribution of ions in the junction region, the models of Planck [i] and Henderson [ii, iii] being the most conventional. The general expression for $\Delta\varphi_{\text{diff}}$ at the interface of liquid solutions (1) and (2) is as follows:

$$\Delta\varphi_{\text{diff}} = -\frac{RT}{F} \int_{(1)}^{(2)} \sum \frac{t_i}{z_i} d \ln a_i$$

where t_i is the \rightarrow transport number of the i -th ion, z_i and

a_i are the charge and \rightarrow activity of this ion, respectively. In the first approximation, $\Delta\varphi_{\text{diff}}$ can be estimated by substituting corresponding concentrations for the partial activities. In Planck's model for a sharp boundary, for 1,1-electrolyte,

$$\Delta\varphi_{\text{diff}} = \frac{RT}{F} \ln \xi,$$

where function ξ can be found from a transcendental equation in which "+" and "-" denote the sets which consist of all cations and of all anions, respectively, and λ denotes the limiting conductivity of the corresponding ion:

$$\xi = \frac{\sum_+ \lambda_+^{(2)} c_+^{(2)} - \sum_+ \lambda_+^{(1)} c_+^{(1)}}{\sum_- \lambda_-^{(2)} c_-^{(2)} - \xi \sum_- \lambda_-^{(1)} c_-^{(1)}} = \frac{\ln \left(\frac{\sum_i c_i^{(2)} / \sum_i c_i^{(1)}}{\sum_i c_i^{(2)} / \sum_i c_i^{(1)}} \right) - \ln \xi \cdot \frac{\xi \sum_i c_i^{(2)} - \sum_i c_i^{(1)}}{\sum_i c_i^{(2)} - \xi \sum_i c_i^{(1)}}}{\ln \left(\frac{\sum_i c_i^{(2)} / \sum_i c_i^{(1)}}{\sum_i c_i^{(2)} / \sum_i c_i^{(1)}} \right) + \ln \xi \cdot \frac{\xi \sum_i c_i^{(2)} - \sum_i c_i^{(1)}}{\sum_i c_i^{(2)} - \xi \sum_i c_i^{(1)}}}$$

The Henderson equation which has gained wider acceptance, can be written as follows for concentrations c having the units of normality:

$$\Delta\varphi_{\text{diff}} = \frac{RT}{F} \cdot \frac{\sum_i \left(\frac{\lambda_i}{z_i} \right) \cdot (c_i^{(2)} - c_i^{(1)})}{\sum_i \lambda_i \cdot (c_i^{(2)} - c_i^{(1)})} \ln \frac{\sum_i \lambda_i c_i^{(1)}}{\sum_i \lambda_i c_i^{(2)}}$$

The solution is given for the case of a smeared-out boundary and linear spatial distributions of concentrations. Generally, Henderson and Planck equations yield similar results; however, for junctions with a pronounced difference in ion \rightarrow mobilities (like HCl:LiCl), the deviation can reach about 10 mV. A specific feature of the Planck equation is the existence of two solutions, the first being close to that of Henderson, and the second one being independent of the solution concentration and of no physical meaning [iv]. Two particular types of liquid junctions are (a) two solutions of the same electrolyte at different concentrations and (b) two solutions at the same concentration with different electrolytes having an ion in common. For type (b) junctions, the simplification of the Henderson model results in the Lewis-Sargent equation:

$$\Delta\varphi_{\text{diff}} = \pm \frac{RT}{F} \ln \frac{\lambda^{(1)}}{\lambda^{(2)}},$$

where + and - correspond to the junctions with common cation and anion, respectively.

Systematic descriptions related to diffusion p. can be found in [v, vi]. In practice, in place of model calculations and corresponding corrections, the elimination of the diffusion potential is conventionally applied. This is achieved by introducing \rightarrow salt bridges filled with concentrated solutions of salts, which contain anions and cations of close transport numbers (saturated KCl, KNO₃, or NH₄NO₃). However, the requirement of equal transport numbers is less important as compared with that of high concentration of electrolyte solution, which fills the bridge. A suitable version of the salt bridge can be chosen for any type of cells, when taking into account the kind of studies and the features of the chosen electrodes.

Refs.: [i] Planck M (1890) *Ann Phys* 40:561; [ii] Henderson P (1907) *Z phys Chem* 59:118; [iii] Henderson P (1908) *Z phys Chem* 63:325; [iv] Damaskin BB, Tsirlina GA, Borzenko MI (1998) *Russ J Electrochem* 34:199; [v] Bard AJ, Faulkner LR (2001) *Electrochemical methods*, 2nd edn. Wiley, New York, chap 2; [vi] Hamann CH, Vielstich W (2005) *Elektrochemie*, 4th edn. Wiley-VCH, Weinheim, chap 3

GT, OP

Dimensionless potential — is the value of \rightarrow electrode potential normalized per RT/F , where R is the \rightarrow gas constant, T is the absolute temperature, and F is the \rightarrow Faraday constant.

See also \rightarrow dimensionless analysis, and \rightarrow dimensionless parameters.

GT

Distribution (Nernst) potential — Multi-ion partition equilibria at the \rightarrow interface between two immiscible electrolyte solutions give rise to a \rightarrow Galvani potential difference, $\Delta_o^w \phi = \phi^w - \phi^o$, where ϕ^w and ϕ^o are the \rightarrow inner potentials of phases w and o. This potential difference is called the distribution potential [i]. The theory was developed for the system of N ionic species i ($i = 1, 2, \dots, N$) in each phase on the basis of the \rightarrow Nernst equation, the \rightarrow electroneutrality condition, and the mass-conservation law [ii]. At equilibrium, the equality of the \rightarrow electrochemical potentials of the ions in the adjacent phases yields the Nernst equation for the ion-transfer potential,

$$\begin{aligned}\Delta_o^w \phi &= \phi^w - \phi^o = \Delta_o^w \phi_i^{\ominus} + \frac{RT}{z_i F} \ln \frac{a_i^o}{a_i^w} \\ &= \Delta_o^w \phi_i^{\ominus'} + \frac{RT}{z_i F} \ln \frac{c_i^o}{c_i^w}\end{aligned}$$

where a_i 's are the ion activities, c_i 's are the equilibrium ion concentrations, z_i 's are the ion charge numbers, and $\Delta_o^w \phi_i^{\ominus}$ or $\Delta_o^w \phi_i^{\ominus'}$ represent the standard or formal ion-transfer potentials, respectively. The standard ion-transfer potential is defined by

$$\Delta_o^w \phi_i^{\ominus} = \frac{\Delta G_{tr,i}^{\ominus,w \rightarrow o}}{z_i F} = \frac{\mu_i^{\ominus,o} - \mu_i^{\ominus,w}}{z_i F}$$

where μ_i^{\ominus} are the standard chemical potentials, and $\Delta G_{tr,i}^{\ominus,w \rightarrow o}$ is the standard Gibbs energy of ion transfer in the direction $w \rightarrow o$. The electroneutrality condition for each phase reads

$$\sum_{i=1}^N z_i c_i^{w,o} = 0.$$

Assuming the absence of ion association or complexation, the mass-conservation law for each ionic species has the form

$$c_i^w + r c_i^o = c_i^{w,0} + r c_i^{o,0}.$$

A substitution into the electroneutrality condition yields an implicit equation for the distribution potential

$$\sum_{i=1}^N z_i \frac{c_i^{0,w} + r c_i^{0,o}}{1 + r P_i'} = 0$$

where $r = V^w/V^o$ is the ratio of the volume of the phase w to that of the phase o, $c_i^{0,s}$ are the initial concentrations of the ion i , and $P_i' = c_i^o/c_i^w = \exp[z_i F(\Delta_o^w \phi - \Delta_o^w \phi_i^{\ominus'})/RT]$ is the apparent ion partition coefficient [ii]. An analogous treatment was used to calculate the distribution potential for the systems comprising the partial dissociation of electrolytes and the complex formations, which shift the ion partition equilibrium in favor of one or the other phase [iii].

An explicit equation for the distribution potential can be obtained only in some limiting cases [ii]. The simplest one is the partition of a single binary electrolyte $R_{\nu+} X_{\nu-}$, which completely dissociates into ions in both phases. In this two-ion partition case, the distribution potential depends neither on the volume ratio r , nor directly on the electrolyte concentration (nonpolarizable interface, see also \rightarrow interface between two immiscible electrolyte solutions) [i],

$$\Delta_o^w \phi = \frac{z_+ \Delta_o^w \phi_{R^+}^{\ominus'} + |z_-| \Delta_o^w \phi_{X^-}^{\ominus'}}{z_+ + |z_-|}.$$

The partition equilibrium of a single \rightarrow binary electrolyte can be also characterized by the measurable parameter, i.e., the partition coefficient of the electrolyte P_{RX} ,

$$P_{RX} = \exp \left[-\frac{\Delta G_{tr,RX}^{\ominus,w \rightarrow o}}{(\nu_+ + \nu_-)RT} \right] = \frac{a_{\pm}^o}{a_{\pm}^w} = \frac{\gamma_{\pm}^o c_{RX}^o}{\gamma_{\pm}^w c_{RX}^w}$$

where $\Delta G_{tr,RX}^{\ominus,w \rightarrow o} = \nu_+ \Delta G_{tr,R^+}^{\ominus,w \rightarrow o} + \nu_- \Delta G_{tr,X^-}^{\ominus,w \rightarrow o}$ is the standard Gibbs energy of the transfer of the electrolyte

$R_{\nu+}X_{\nu-}$ from w to o, a_{\pm} 's are the mean activities, γ_{\pm} 's are the mean activity coefficients, and c_{RX} 's are the equilibrium electrolyte concentrations. A non-thermodynamic assumption has to be introduced to construct the scale of the inner (Galvani) potential differences from the partition measurements. The most commonly used hypothesis is that the tetraphenylarsonium cation (Ph_4As^+) and the tetraphenylborate anion (Ph_4B^-) have equal standard Gibbs energies of transfer for any combination of two solvents [iv]. This assumption enables the evaluation of $\Delta G_{\text{tr,Ph}_4\text{As}^+}^{\ominus,w \rightarrow o}$ and $\Delta G_{\text{tr,Ph}_4\text{B}^-}^{\ominus,w \rightarrow o}$ from the partition measurements of $\text{Ph}_4\text{AsPh}_4\text{B}$. Standard Gibbs energies of transfer of other ions are then obtained from the partition measurements of their salts with Ph_4As^+ or Ph_4B^- . Alternatively, the standard Gibbs energy of transfer of an electrolyte can be evaluated from the ratio of the electrolyte solubility in the two solvents [v].

Two other macroscopic systems are of practical interest. First one consists of a hydrophobic electrolyte RY in the organic solvent and an electrolyte RX with the same cation R^+ in water. Provided that $r = 1$, the ion activity coefficients are unity and $\Delta_o^w \phi_{R^+}^{\ominus} - \Delta_o^w \phi_{X^-}^{\ominus} \gg 4(c_{RX}^0/c_{RY}^0)(1 + c_{RX}^0/c_{RY}^0)$, the distribution potential for this three-ion partition system is determined by the equilibrium partition of the common cation R^+ [i]

$$\Delta_o^w \phi = \Delta_o^w \phi_{R^+}^{\ominus} + \frac{RT}{F} \ln \frac{c_{R^+}^o}{c_{R^+}^w}.$$

A second system consists of a hydrophobic electrolyte SY in the organic solvent and a hydrophilic electrolyte RX in water, the partition equilibria of which are shifted in favor of the organic or the aqueous phase, respectively [vi]. An application of the treatment above to this four-ion partition case shows that the distribution potential fulfils the inequality $\Delta_o^w \phi_{S^+}^{\ominus}, \Delta_o^w \phi_{X^-}^{\ominus} \ll \Delta_o^w \phi \ll \Delta_o^w \phi_{R^+}^{\ominus}, \Delta_o^w \phi_{Y^-}^{\ominus}$ indicating that no stable distribution potential can be established [ii]. The state of such systems can be controlled by the externally supplied charge (ideally polarizable interface, see also \rightarrow *interface between two immiscible electrolyte solutions*) [vi].

In emulsion or liquid membrane systems, the volume ratio approaches one of the limiting values $r \rightarrow 0$ and $r \rightarrow \infty$, and the distribution potential becomes independent of r [vii].

Refs.: [i] Karpfen FM, Randles JEB (1953) *Trans Faraday Soc* 49:823; [ii] Hung LQ (1980) *J Electroanal Chem* 115:159; [iii] Hung LQ (1983) *J Electroanal Chem* 149:1; [iv] Parker AJ (1969) *Chem Rev* 69:1; [v] Abraham MH (1971) *J Chem Soc B*:299; [vi] Koryta J, Vanýšek P, Březina M (1977) *J Electroanal Chem* 211:75; [vii] Kakiuchi T (1996) *Anal Chem* 68:3658

ZSam

Donnan potential — is the potential drop across $a \rightarrow$ *membrane* (with electrolyte solutions on both sides) which appears when not all of the ions existing in the system can permeate the interface. This drop is named after \rightarrow *Donnan* who was the first to consider these systems on the basis of \rightarrow *Gibbs* thermodynamics [i, ii]. A classical Donnan p. originates from electrolytes separation with solid or liquid semipermeable membranes. This quantity can be expressed via the activities of ions capable of permeating through the boundary(ies). In contrast to the \rightarrow *diffusion potential*, the Donnan p. presents a thermodynamically reversible quantity. This fact forms the basis for the widespread experimental technique of measuring the activities in systems with eliminated diffusion potentials [iii] (see also \rightarrow *ion-selective electrodes*, in particular pH-sensitive \rightarrow *glass electrode*). Under real conditions, Donnan p. can be treated as a sum of the two interfacial potential drops on both sides of the membrane (usually the overall membrane is not fully permeated by the ions). Donnan potentials are very important for treating physiological phenomena. Donnan-like equilibria are typical for ionexchanger|solution and various liquid|liquid interfaces if some ions are strongly bonded in one of the contacting phases. See also \rightarrow *Donnan equilibrium*.

Refs.: [i] Donnan FG (1911) *Z Elektrochem* 17:572; [ii] Donnan FG, Guggenheim EA (1932) *Z phys Chem* 162A:346; [iii] Kahlert H (2002) *Potentiometry*. In: Scholz F (ed) *Electroanalytical methods*. Springer, Berlin

GT, OP

Electrical potential — (SI Unit: V or J C^{-1}) represents the electrical \rightarrow *energy* (\rightarrow *work*, *electrical*) which is necessary in transferring a unit test charge from infinity in vacuum into the phase under consideration. This charge (probe, or test charge, or imaginary charge) is assumed to be affected only by the external \rightarrow *electric field* and does not interact with the medium via non-coulombic forces. It is sufficiently small as not to induce any charge redistribution inside the phase. In actual practice, the charges exist only in a combination with certain species (elementary particles, particularly, \rightarrow *electrons* and \rightarrow *ions*). Hence, the value of the electrical potential appears to be beyond the reach of experimental determination. The latter leads to the problems concerning the interpretation of the \rightarrow *electrode potential*, and it leads to numerous potential scales. A number of discussions of various levels can be found in the literature [i–v].

Refs.: [i] Frumkin AN (1928) *Ergeb exact Naturwiss* 7:235; [ii] Frumkin A, Gorodetzka A (1928) *Z phys Chem* 136:215; [iii] Parsons R (1954) *Equilibrium properties of electrified interphases*. In: Bockris JO'M (ed)

Modern aspects of electrochemistry, vol. 1. Butterworth, London, p 103; [iv] Trasatti S (1980) In: Bockris JO'M, Conway BE, Yeager E (eds) Comprehensive treatise of electrochemistry, vol. 1. Plenum Press, New York, p 45; [v] Vetter KJ (1961) Electrochemische Kinetik. Springer, Berlin

GT, OP

Electrochemical potential → electrochemical potential

Electrode potential — Symbol: E (SI unit: V). → Electric potential difference of an → electrochemical cell (including the condition when → current flows through the cell), and the left-hand electrode in the diagram of the galvanic cell (→ cell diagram) is at virtual equilibrium, and hence acting as a → reference electrode. In → electrolysis cells the potential of the → working electrode is compared to a reference electrode which is practically at equilibrium. The → liquid junction potential is assumed to be eliminated. When the right-hand electrode is also at equilibrium the measured potential is the → equilibrium electrode potential. When the electrode investigated in aqueous medium is at equilibrium and in its standard state as well as the reference electrode is the → standard hydrogen electrode the → standard electrode potential can be determined. In nonaqueous solvents it is necessary to use another standard reaction than the ionization of hydrogen.

See also → three-electrode system, → two-electrode system.

Refs.: [i] Mills I, Cvitas T, Homann K, Kallay N, Kuchitsu K (eds) (1993) IUPAC quantities, units and symbols in physical chemistry. Blackwell Scientific Publications, Oxford, p 59–61; [ii] Parsons R (1974) Manual of symbols and terminology for physicochemical quantities and units. Appendix III. Electrochemical nomenclature. Pure Appl Chem 37:503

GI

Equilibrium electrode potential — is the value of → electrode potential determined exclusively by a single redox system ox/red in the absence of current and under complete equilibration. The rates of ox to red reduction and of red to ox oxidation processes are equal under these circumstances (see → exchange current density). The value of equilibrium e.p. is determined by the → Nernst equation. Equilibrium e.p. presents a → redox potential in its fundamental sense. See also → reversibility.

GT, OP

Flade potential → electrode potential E_F of a metal in contact with a corrosive electrolyte solution where the current associated with the anodic metal dissolution (→ corrosion, active region) drops to very small values. See also → Flade, and → passivation.

Ref.: [i] Kaesche H (2003) Corrosion of metals. Springer, Berlin

RH

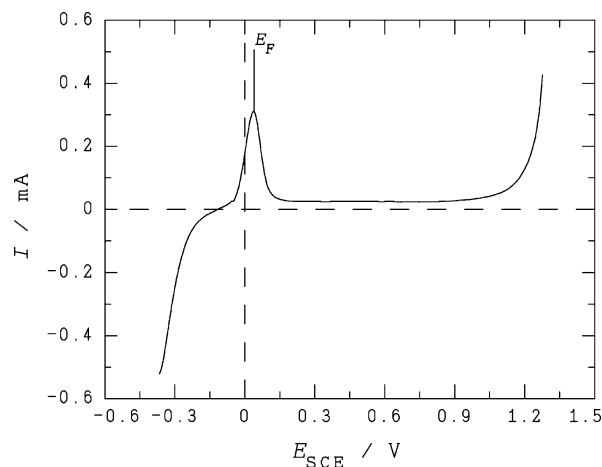

Potential — Flade potential — Figure. Voltammogram of a stainless steel electrode in contact with an aqueous sulfuric acid solution

P

Flat-band potential — In the energy barrier formed for example at metal–semiconductor junctions (→ Schottky barrier), metal–insulator–semiconductor junctions, and solution–semiconductor interfaces the flat-band potential corresponds to the potential at which the electric field equals zero at the semiconductor interface, i.e., there is no → band bending. In case of solution–semiconductor interfaces, the flat-band potential corresponds to the condition of absence of excess charge and consequently, depletion layer, in the semiconductor. See also → Mott–Schottky plot, and → semiconductor.

Refs.: [i] Ng KK (2002) Complete guide to semiconductor devices. Wiley, New York; [ii] Sze SM (1981) Physics of semiconductor devices. Wiley, Singapore; [iii] Bard AJ, Faulkner LR (2001) Electrochemical methods, 2nd edn. Wiley, New York

IH

Formal potential — Symbol: $E_c^{\ominus'}$ (SI Unit: V), has been introduced in order to replace the → standard potential of → cell reaction when the values of → activity coefficients of the species involved in the cell reaction are unknown, and therefore concentrations used in the equation expressing the composition dependence of E_{cell} instead of activities. It also involves the activity effect regarding the → standard hydrogen electrode, consequently in this way the formal electrode potential is also defined. Formal potentials are similar to → conditional (apparent) equilibrium constants (→ equilibrium constant), in that, beside the effect of the activity coefficients, side reaction equilibria are also considered if those are not known or too complex to be taken into account. It follows that when the logarithmic term which contains the ratio of concentrations in the → Nernst

equation is zero, the measured potential is the formal electrode potential.

Formal potentials can be defined on different levels of conditions: Thus the formal potential of the → *quinhydrone electrode* may be defined (I) as including (a) the standard potential of the hydroquinone dianion/quinone system, (b) the two acidity constants of the hydroquinone, and (c) the activity coefficients of the hydroquinone dianion and quinone, or, (II), it may also include (c) the pH value. In the latter case, for each pH value there is one formal potential, whereas in the first case one has one formal potential for all pH values, and an equation describing the dependence of the electrode potential as a function of that formal potential and the individual pH values. Formal potentials are strictly thermodynamic quantities, and no kinetic effects (e.g., by electrochemical → *irreversibility*) are considered.

Refs.: [i] Parsons R (1974) *Pure Appl Chem* 37:503; [iii] Inzelt G (2006) *Standard potentials*. In: Bard AJ, Stratmann M, Scholz F, Pickett CJ (eds) *Inorganic electrochemistry. Encyclopedia of electrochemistry*, vol. 7a. Wiley, Weinheim, chap 1; [iii] Bard AJ, Faulkner LR (2001) *Electrochemical methods*, 2nd edn. Wiley, New York, chap 2, pp 52–53; [iv] Scholz F (2002) *Thermodynamics of electrochemical reactions*. In: Scholz F (ed) *Electroanalytical methods*. Springer, Berlin

GI, FS

Galvani potential difference — $\Delta_{\alpha}^{\beta} \phi$ determines the electrostatic component of the work term corresponding to the transfer of charge across the → *interface* between the phases α and β whose → *inner electric potentials* are ϕ^{α} and ϕ^{β} , respectively, i.e., the Galvani potential difference is the difference of inner electric potentials of the contacting phases. The electrical potential drop can be measured only between the points which find themselves in the phases of one and the same chemical composition [i, ii]. Indeed, in this case $\mu_i^{\beta} = \mu_i^{\alpha}$ and $\Delta_{\alpha}^{\beta} \phi = \phi^{\beta} - \phi^{\alpha} = \frac{\bar{\mu}_i^{\beta} - \bar{\mu}_i^{\alpha}}{z_i F}$, whereas the “chemical” component is determined by the difference of chemical potentials (μ_i is the → *chemical potential* of the species i , and $\bar{\mu}_i$ is its → *electrochemical potential*). Otherwise, when the points belong to two different phases, the experimental determination of the potential drop is impossible. In the literature, the term Galvani potential is also applied to the separate value of → *inner potential*; it was named initially as the → *absolute electrode potential*.

Refs.: [i] Parsons R (1954) *Equilibrium properties of electrified interphases*. In: Bockris JO'M (ed) *Modern aspects of electrochemistry*, vol. 1. Butterworth, London, p 103; [ii] Parsons R (1974) *Pure Appl Chem* 37:503

GT, OP

Half-wave potential — ($E_{1/2}$) is the potential value corresponding to a half of the limiting current for

various wave-shaped electrochemical responses (→ *polarography*, → *normal pulse voltammetry* and other techniques). Half-wave p. is one of the most typical → *characteristic potentials* used as a compound-specific parameter (of course, depending on the used solvent). The relations of half-wave p., voltammetric → *peak p.* and → *formal potentials* can be found in [i–iii]. This quantity is sometimes mistakenly used as synonym for formal potential, or even standard potential. In reality it is affected by non-thermodynamic (kinetic) quantities. For a reversible polarographic wave and a solution containing both the oxidized (ox) and the reduced (red) species, $E_{1/2}$ deviates from the formal potential $E_c^{\ominus'}$ due to the → *diffusion coefficients* D of the oxidized (ox) and reduced (red) species :

$$E_{1/2} = E_c^{\ominus'} + \frac{RT}{F} \ln \frac{\gamma_{\text{ox}} D_{\text{ox}}^{1/2}}{\gamma_{\text{red}} D_{\text{red}}^{1/2}},$$

for less reversible waves the value of $E_{1/2}$ is also affected by the rate constant of the → *electron transfer* reaction [i]. Refs.: [i] Galus Z (1994) *Fundamentals of electrochemical analysis*, 2nd edn. Ellis Horwood, New York, Polish Scientific Publisher PWN, Warsaw; [ii] Wang J (2001) *Analytical electrochemistry*, 2nd edn. Wiley-VCH, New York, chap 2; [iii] Scholz F (2002) *Thermodynamics of electrochemical reactions*. In: Scholz F (ed) *Electroanalytical methods*. Springer, Berlin

GT, OP

Inner electric (or internal electric) potential, ϕ^{α} — within the phase α is related to the → *electric field strength* E in the interior of the phase by $-\Delta\phi = E$. It is the sum of the → *outer (or external) electric potential* ψ^{α} and the → *surface potential* χ^{α} , and it characterizes the electrical state of any phase α : [i–iv]. When the free electrostatic charge in the phase α turns to zero, $\psi^{\alpha} = 0$ and $\phi^{\alpha} = \chi^{\alpha}$. In general, the inner potential is not measurable. See also → *Lange*.

Refs.: [i] Schottky W, Rothe H (1928) *Physik der Glühelktroden*. In: Wien W, Harms F, Lenz H (eds) *Handbuch der Experimentalphysik*, vol. 13. Akademie Verlag, Leipzig, S 145; [ii] Lange E, Miscenko KP (1930) *Z phys Chem* 149A:1; [iii] Lange E (1952) *Z Elektrochem* 56:94; [iv] Parsons R (1974) *Pure Appl Chem* 37:503

GT, OP

Interfacial potential (difference) — Synonym for → *Galvani potential difference*. The latter term should be preferred.

FS

IR potential drop — is the phenomenon induced by the existence of the → *ohmic resistance* in an electrochemical cell. It complicates the precise measurement of potential by contributing to the experimentally ob-

served difference in the potentials of working and reference electrodes and depends on the values of \rightarrow current I and the \rightarrow resistance R of the solution separating the two above-mentioned electrodes. The IR potential drop can be also located inside a semiconducting electrode or inside the porous layer of a gas-diffusion electrode (\rightarrow porous electrodes). If voltammetric and related techniques are used in a \rightarrow three-electrode system, the ohmic drop can be compensated (now this is usually done by the software or hardware of electrochemical devices that provide positive feedback [i] (\rightarrow potentiostat)). Another compensation mode is named 'current interruption', i.e., periodic measuring of potential decay under open circuit for several μ s with subsequent automatic recalculation of the potential value (the initial fast potential decrease after interruption is assumed to be equal to the IR potential drop). To reduce the IR potential drop, one can use a \rightarrow Luggin capillary [ii] and/or an increase of the concentration of supporting electrolyte. A useful way to handle an IR potential drop is to add a known reference redox system (e.g., ferrocene/ferrocenium) to the studied solution, especially when voltammetry-like techniques are applied, and to relate the characteristic potential of the unknown system to the characteristic potential of that reference system, as the latter will be shifted by the same IR potential drop (when corrected for differences in current). In \rightarrow two-electrode systems and industrial electrolytic baths, the term IR potential drop is applied to the potential drop between the electrodes contributing to the total cell voltage. To decrease this drop, the electrodes should be as close to each other as possible. The presence of gas bubbles in solution (typical for many industrial processes) increases the IR potential drop, and cell optimization includes a search for geometry and convection mode minimizing this effect. The IR potential drop decreases the voltage provided by electrochemical power sources and requires additional energy for electrolytic bath operation, with simultaneous generation of Joule heat.

Refs.: [i] Souto RM (1994) *Electroanalysis* 6:531; [ii] Vetter KJ (1961) *Elektrochemische Kinetik*. Springer, Berlin

GT, OP

Liquid-junction potential \rightarrow liquid-junction potential, and \rightarrow diffusion potential

Mid-peak potential in cyclic voltammetry — (E_{mp}) is a quantity determined by the formula

$$E_{mp} = \frac{E_{pa} + E_{pc}}{2}$$

where E_{pa} is the anodic \rightarrow peak potential, and E_{pc} is the

cathodic peak potential. For completely electrochemically reversible processes, and when the \rightarrow symmetry coefficient is 0.5, E_{mp} is equal to the \rightarrow formal potential.

Refs.: [i] Galus Z (1994) *Fundamentals of electrochemical analysis*, 2nd edn. Ellis Horwood, New York, Polish Scientific Publisher PWN, Warsaw; [ii] Wang J (2001) *Analytical electrochemistry*, 2nd edn. Wiley-VCH, New York, chap 2; [iii] Scholz F (2002) *Thermodynamics of electrochemical reactions*. In: Scholz F (ed) *Electroanalytical methods*. Springer, Berlin

GT, OP

Mixed potential — is the value of the potential of a given electrode with respect to a suitable \rightarrow reference electrode when appreciable contributions to the total anodic and/or cathodic \rightarrow partial current are made by species belonging to two or more different redox couples, but the total current is zero [i]. The deviation of the mixed potential from the equilibrium potentials of contributing redox couples depends on the ratio of the \rightarrow exchange current densities and other properties of the system, e.g., on the value of the diffusion \rightarrow limiting current. Typically two redox couples are present and the mixed potential developing in such a way that the anodic and cathodic partial currents do not belong to the same redox couple, e.g., the anodic partial current is due to the dissolution of a metal, while the cathodic one is oxygen reduction [i]. Mixed potentials are crucial in the understanding of \rightarrow corrosion (see also \rightarrow corrosion potential). It was also named stationary p. or compromise p. In potentiometric experiments the mixed nature of potential can be harmful for the determination of basic thermodynamic quantities, pH-metric applications, and also the analytical techniques based on ion-selective electrodes.

Refs.: [i] Heusler KE (1996) *Electrochim Acta* 41:411; [ii] Wagner C, Traud W (1938) *Z. Elektrochem* 44:391; [iii] Vetter KJ (1961) *Elektrochemische Kinetik*. Springer, Berlin; [iv] Vetter KJ (1967) *Electrochemical kinetics*. Academic Press, New York

GT, OP

Open-circuit potential (OCP) — This is the \rightarrow potential of the \rightarrow working electrode relative to the \rightarrow reference electrode when no potential or \rightarrow current is being applied to the \rightarrow cell [i]. In case of a reversible electrode system (\rightarrow reversibility) the OCP is also referred to as the \rightarrow equilibrium potential. Otherwise it is called the \rightarrow rest potential, or the \rightarrow corrosion potential, depending on the studied system. The OCP is measured using high-input \rightarrow impedance voltmeters, or potentiometers, as in \rightarrow potentiometry. OCP's of \rightarrow electrodes of the first, the second, and the third kind, of \rightarrow redox electrodes and of \rightarrow ion-selective membrane electrodes are defined by the \rightarrow Nernst equation. The \rightarrow corrosion po-

tential is not an equilibrium potential, but a \rightarrow *mixed potential*. This is the electrode potential spontaneously acquired by a corroding material in a particular environment, relative to a reference electrode and measured under open-circuit conditions [ii]. It is also called the freely corroding potential and the rest potential. OCP of a \rightarrow *battery* is the difference in potentials of two working electrodes.

Refs.: [i] Bard AJ, Faulkner LR (2001) *Electrochemical methods*, 2nd edn. Wiley, New York; [ii] Heusler KE, Landolt D, Trasatti S (1989) *Pure Appl Chem* 61:19

SKL

Overpotential — is the deviation of the \rightarrow *electrode potential* from its equilibrium value required to cause a given \rightarrow *current density* to flow through the electrode. This notion is widely applied to the qualitative characteristic of electrode activity in various reactions, namely low overpotential means high activity, and high overpotential means low activity (it is assumed that the values of overpotentials are compared for some fixed current density and solution composition). See also \rightarrow *activation overpotential*, \rightarrow *crystallization overpotential*, \rightarrow *diffusion overpotential*, \rightarrow *reaction overpotential*.

GT, OP

Outer electric (external) potential — ψ^α represents the electrical energy necessary to transfer the probe charge from infinity to the point in the closest vicinity of the surface of a certain phase α . The distances from this point to the interface should be sufficiently large, as compared with the characteristic distance of molecular and image forces (up to 10^{-4} cm), and, at the same time, not too large to prevent the weakening of interaction with the charges inside the phases. Free electrostatic charges of the phase are responsible for ψ^α value. See \rightarrow *inner (or internal) electric potential*; \rightarrow *Volta (contact) potential*.

GT, OP

Peak potential — is a term used in \rightarrow *voltammetry* for the potential of the working (indicator) electrode at which the peak current is attained. In the cyclic voltammogram of a reversible redox couple, anodic and cathodic peak p. are separated by $2.2RT/nF$, which is considered as a diagnostic feature and gives a possibility to determine the \rightarrow *formal p.* as a \rightarrow *mid-peak p.* For irreversible couples, quantitative relations exist, interconnecting peak p. and the rate constant of the \rightarrow *electron transfer*.

Refs.: [i] Galus Z (1994) *Fundamentals of electrochemical analysis*, 2nd edn. Ellis Horwood, New York, Polish Scientific Publisher PWN, Warsaw; [ii] Wang J (2001) *Analytical electrochemistry*, 2nd edn. Wiley-VCH, New York, chap 2; [iii] Scholz F (2002) *Thermodynamics of electro-*

chemical reactions. In: Scholz F (ed) *Electroanalytical methods*. Springer, Berlin

GT, OP

Potential at half-height — (in \rightarrow *voltammetry*)

This is a diagnostic criterion in \rightarrow *linear scan voltammetry*. The potential at half-height $E_{p/2}$ is the potential at which the current is equal to one-half of the peak current I_p : $E_{p/2} = E_{(I=I_p/2)}$. The first of two potentials at half-height, the one that precedes the peak potential (E_p) is considered only. If a simple electrode reaction is reversible (\rightarrow *reversibility*) and controlled by the planar, semi-infinite \rightarrow *diffusion*, the absolute value of the difference between $E_{p/2}$ and E_p is equal to $56.6/n$ mV and independent of the \rightarrow *scan rate*. If the \rightarrow *electrode reaction* of dissolved reactant is totally irreversible (\rightarrow *reversibility*), the difference $E_{p/2} - E_p$ is equal to $47.7/\alpha n$ mV for the cathodic process and $-47.7/(1-\alpha)n$ mV for the anodic process.

Ref.: [i] Marken F, Neudeck A, Bond AM (2002) *Cyclic voltammetry*. In: Scholz F (ed) *Electroanalytical methods*. Springer, Berlin, p 51

MLo

Potential-energy profile — is a curve describing the variation of the potential energy of the system of atoms that make up the reactants and products of a reaction as a function of one geometric coordinate, and corresponding to the “energetically easiest passage” from reactants to products (i.e., along the line produced by joining the paths of steepest descent from the \rightarrow *transition state* to the reactants and to the products). For an \rightarrow *elementary reaction* the relevant geometric coordinate is the reaction coordinate; for a stepwise reaction it is the succession of reaction coordinates for the successive individual reaction steps. (The reaction coordinate is sometimes approximated by a quasichemical index of reaction progress, such as “degree of atom transfer” or bond order of some specified bond.) See also \rightarrow *potential-energy (reaction) surface*, \rightarrow *Gibbs energy diagram*, \rightarrow *Marcus theory*.

Ref.: [i] Muller P (1994) *Pure Appl Chem* 66:1077

WK

Potential-energy (reaction) surface — is a geometric hypersurface on which the potential energy of a set of reactants is plotted as a function of the coordinates representing the molecular geometries of the system.

For simple systems two such coordinates (characterizing two variables that change during the reaction progress from reactants to products) can be selected, and the potential energy plotted as a contour map.

For simple \rightarrow *elementary reactions*, e.g., $A-B + C \rightarrow A + B-C$, the surface can show the potential energy for

all values of the A, B, C geometry, providing that the ABC angle is fixed.

For more complicated reactions a different choice of two coordinates is sometimes preferred, e.g., the bond orders of two different bonds. Such a diagram is often arranged so that reactants are located at the bottom left corner and products at the top right. If the trace of the representative point characterizing the route from reactants to products follows two adjacent edges of the diagram, the changes represented by the two coordinates take place in distinct succession: if the trace leaves the edges and crosses the interior of the diagram, the two changes are concerted. In many qualitative applications it is convenient (although not strictly equivalent) for the third coordinate to represent the standard → *Gibbs energy* rather than potential energy. Using bond orders is, however, an oversimplification, since these are not well defined, even for the transition state. (Some reservations concerning the diagrammatic use of Gibbs energies are noted under → *Gibbs energy diagram*.) The energetically easiest route from reactants to products on the potential–energy contour map defines the potential–energy profile. See also → *linear free energy relationships*.
Ref.: [i] Muller P (1994) *Pure Appl Chem* 66:1077

WK

Potential gradient in electrochemical cell — arises when → *IR potential drop* is significant, see → *migration*.

OP

Potential of the cell reaction → *galvanic cell*

Potential of mean force — The force that a particle in a particular ensemble experiences is, in principle, a function of the position of all other particles. Often one is interested in the average force that a particular particle experiences as a function of its position in space. Conceptually, this can be calculated by keeping the position of this test particle constant and averaging over the positions of all other particles. By varying the position of the particle, this mean force is obtained as a function of position. The corresponding potential, from which this average force can be derived, is the potential of mean force.

WS

Potential of zero charge → *point of zero charge*

Potential–pH diagram — Graphical display of electrode potentials (usually on the SHE-scale) vs. → *pH* values for a selected element based on thermodynamic calculations. In the plot the chemically stable species are indicated taking into account all conceivable electrochemical as well as chemical reactions. Initially proposed and extensively researched by → *Pourbaix*.

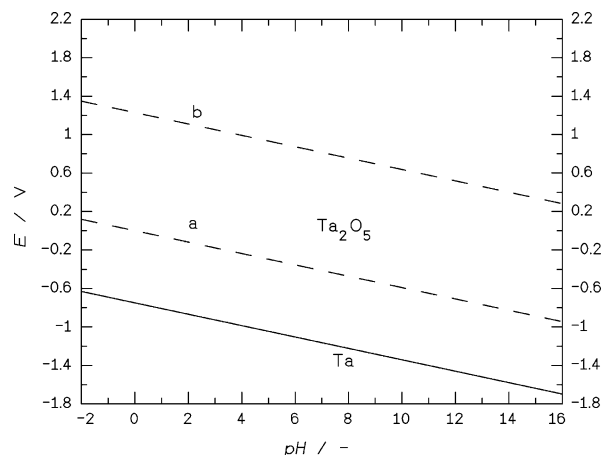

Potential — Potential–pH diagram — Figure. Potential–pH diagram of the system tantalum/water. The dashed lines correspond to the equilibrium conditions of the hydrogen/water couple (a) and the oxygen/water couple (b). The full line separates the potential–pH-region wherein tantalum is stable from the region wherein Ta_2O_5 is stable

P

Ref.: [i] Pourbaix M (1966) *Atlas of the electrochemical equilibria in aqueous solutions*. Pergamon Press, Oxford

RH

Potential-ramp techniques → *voltammetry*

Potential scan rate → *potential sweep rate*

Potential series → *potential*, and subentries → *standard potential*, and → *tabulated standard potentials*

Potential step techniques — A wide group of electrochemical methods in which the current or charge is continuously or alternately sampled when a combined sequence of constant potential values is applied between the reference and working electrodes, during specific time periods. Since all potential pulse techniques are based on a combination of potential steps, they all can be enclosed into this group [i]. However, this expression is commonly reserved for typical experiments of → *chronoamperometry*, → *chronocoulometry*, → *staircase voltammetry* and (whenever appropriate) → *tast polarography* (→ *polarography*). See also → *pulse voltammetry* or → *pulse polarography*.

Ref.: [i] Brett CMA, Oliveira Brett AM (2001) *Step and pulse techniques*. In: Bard AJ, Stratmann M, Unwin P (eds) *Instrumentation and electroanalytical chemistry*. *Encyclopedia of electrochemistry*, vol. 3. Wiley-VCH, Weinheim

FG

Potential sweep rate — is the rate of an electrical perturbation to the system in which the potential is changed linearly with time at a certain sweep (scan) rate.

The potential sweep rate is a characteristic parameter in → *voltammetry*.

Potential sweep techniques → *voltammetry*

Potential window — is the width of the potential range in which the solvent, the electrolyte, and the electrode material remain electrochemically inert, and electrochemical processes can be observed without interfering side processes. The potential window is restricted by the potentials of cathodic and anodic background processes. The relative narrow potential window of water (about 1.3–1.4 V on platinum group metals, and up to 2 V on mercury-like metals, which possess a large → *overpotential* for the → *hydrogen evolution reaction*) stimulates the use of → *nonaqueous solvents*. → *Aprotic solvents* usually have windows of about 3–3.5 V width, if the optimal supporting electrolyte is chosen. An extremely wide window is known, for example, for liquid SO₂ (e.g., with CsAsF₆ as electrolyte), which is very attractive to measure extremely positive redox potentials (up to + 6.0 V (vs. SCE) [i]. Low-temperature ionic liquids are highly promising systems [ii, iii]. Finally, a number of unique mixed solvents with extremely wide windows were found in recent studies of → *lithium batteries* [iv]. Among → *electrode materials*, the widest windows are known for transition metal oxides, borides, nitrides, and some specially fabricated carbon-based materials. It is impossible to strictly define the width of a potential window, as that depends always on the current densities set as border limits. The smaller the current signals that ought to be measured, the smaller will be the available potential range for a fixed solvent and electrolyte. See also → *electrochemical window*.

Refs.: [i] Garcia E, Bard AJ (1990) *J Electrochem Soc* 137:2752; [ii] Hussey CL (1994) In: Mamontov G, Popov AI (eds) *Chemistry of nonaqueous solutions*. VCH, New York, p 227; [iii] Bonhote P, Dias A-P, Papageorgiou N, Kalyanasundaram K, Gratzel M (1996) *Inorg Chem* 35:1168; [iv] Xu K, Day ND, Angell CA (1996) *J Electrochem Soc* 143:L209

GT, OP

Rational potential — is the → *electrode potential* in a reduced scale, as referred to → *potential of zero charge* of the same electrode material in solution of given composition. This quantity is used in studies of the → *electric double layer* as the so-called Grahame rational scale [i]. A detailed discussion of the rational p. was given by Antropov [ii].

Refs.: [i] Grahame DC (1947) *Chem Rev* 41:441; [ii] Antropov LI (1960) *Kinetics of electrode processes and null points of metals*. CSIR, New Delhi

GT, OP

Redox potential — (in a fundamental sense) is the equilibrium potential of a redox couple as given by

the → *Nernst equation*. This quantity can be calculated from → *standard p.* or estimated from the experimental value of → *formal p.* A number of empirical and semiempirical correlations of redox potentials with molecular characteristics of substances, especially for the sequences of relative compounds, can be used for semi-quantitative estimates of potentials of novel systems. The most advanced approaches known from coordination chemistry take into account σ -donating and π -accepting abilities of the ligands, which can be expressed, for example, in terms of Hammett or Taft parameters [i]. For the sequences of complexes with different central ions and related ligands, the steric factors (namely, chelating ability) are known to significantly affect the redox potentials. A separate field deals with correlating the redox potentials with spectroscopic parameters, such as the energy of the first allowed d–d transition in a complex, the energy of the metal-to-ligand charge transfer band (i.e., the separation between the HOMO on the metal and LUMO on the ligand), and NMR chemical shifts. The problem of extending these correlations over a wider range of reactions, including irreversible ones was considered a long time ago [ii]. Advanced spectroscopic techniques are widely used for solving the reverse problem of determining the redox potentials of irreversible couples [iii].

Using the term redox p. in relation to any potential measured with an “inert” electrode in various nonequilibrium systems is rather conditional, despite it is frequently used in biological and environmental research. When the value of redox p. is reported, one should pay special attention to the experimental technique applied to determine it, and to check whether it corresponds to redox equilibrium, or to a nonequilibrium situation (possibly nonequilibrium in the solution among the different species, and/or nonequilibrium at the electrode surface). See also → *mixed potential*.

Refs.: [i] Chatt J (1982) *Coord Chem Rev* 43:337; [ii] Vlcek AA (1963) *Progr Inorg Chem* 5:211; [iii] Sanchez F, Perez-Tejeda P, Perez F, Lopez-Lopez M (1999) *J Chem Soc Dalton Trans* 17:3035

GT, OP

Reduction potential — The → *redox potential* or, under standard conditions, the → *standard potential* represents the potential of a given couple, e.g. Zn/Zn²⁺, with respect to the → *standard hydrogen electrode (SHE)* and is usually measured in an electrochemical cell at open circuit with a voltage-measuring device that draws negligible current. The potential measured in this way involves a system at equilibrium and zero current, although drawing very small currents in either direction would not change the value significantly.

For the Zn/Zn²⁺ couple at 25 °C, this value would be -0.76 V, where the negative sign signifies that this electrode is electrostatically more negative than the SHE. One can also relate this potential to the → *electromotive force (emf)* and to thermodynamic measurements (e.g. measurement of Δ*G*[⊖]) for the reaction Zn²⁺ + H₂ → Zn + 2H⁺ or the half-reaction Zn²⁺ + 2e⁻ → Zn. In this case the potential would also be -0.76 V, but here the sign represents the thermodynamic sign (based on energy in or out) rather than the electrostatic one (based on a relative excess or deficiency of electrons). For half-reactions considered in this thermodynamic approach, the sign would change if the half-reaction were written as an oxidation (and the protons were reduced to hydrogen). To obtain agreement between the electrostatic and thermodynamic sign conventions, one then usually writes half-reactions as reductions and the potential is sometimes called a “reduction potential,” although such usage is not recommended over the term “standard potential.” In general, this term applies to the potential derived from the reaction oxidized form + hydrogen → reduced form + (hydrated) protons [i, ii].

The term is sometimes also used, incorrectly, to mean the potential at which a reduction occurs. In general, the terms “reduction” and “oxidation”, as well as “cathodic” and “anodic”, that imply reaction directions, should not be associated with the term “potential”.

Refs.: [i] Bard AJ, Faulkner LR (2001) *Electrochemical methods*. Wiley, New York, pp 48–49; [ii] Bard AJ, Parsons R, Jordan J (1985) *Standard potentials in aqueous solutions*. Marcel Dekker, New York, Chap 1

AJB, FS

Rest potential — For the first meaning of this term see → *open-circuit potential* and → *corrosion potential*. The rest potential of a biological → *membrane* is the trans-membrane → *potential difference* under → *equilibrium* conditions. It depends on the transport of all → *ions* that can pass through the membrane, the most important of which are sodium and potassium cations. The rest potentials of cell membranes vary from tens to hundreds of millivolts [i]. The third meaning of this term is connected with the resting period in → *hydrodynamic anodic, cathodic, and → adsorptive stripping voltammetry* and → *pseudopolarography*. This is the potential to which the → *working electrode* is charged during the period between the accumulation under hydrodynamic conditions and the stripping into the calm solution. Usually it is equal to the start potential of the stripping scan [ii].

Refs.: [i] Coster H, Smith JR (1978) *Membrane potentials*. In: Milazzo G (ed) *Topics in bioelectrochemistry and bioenergetics*, vol. 2. Wiley, New

York, p 53; [ii] Vydra K, Štulík K, Juláková E (1976) *Electrochemical stripping analysis*. Ellis Horwood, Chichester

SKL

Standard chemical potential — at temperature *T* is the value of the → *chemical potential* under specified standard conditions (see also → *standard electrode potential*).

GT

Standard (electrode) potential — (*E*[⊖]) represents the equilibrium potential of an electrode under standard-state conditions, i.e., in solutions with the relative activities of all components being unity and a pressure being 1 atm (ignoring the deviations of fugacity and activity from pressure and concentration, respectively) at temperature *T*. A pressure of 1 bar = 10⁵ Pa was recommended as the standard value to be used in place of 1 atm = 101,325 Pa (the difference corresponds to 0.34 mV shift of potential). If a component of the gas phase participates in the equilibrium, its → *partial pressure* is taken as the standard value; if not, the standard pressure should be that of the inert gas over the solution or melt. In a certain case, a standard potential can be established in a system with non-unity activities, if the combination of the latter substituted to → *Nernst equation* equals unity. For any solid component of redox systems, the chemical potential does not change in the course of the reaction, and it remains in its standard state. In contrast to the common thermodynamic definition of the standard state, the temperature is ignored, because the potential of the standard → *hydrogen electrode* is taken to be zero at any temperature in aqueous and protic media. The zero temperature coefficient of the standard → *hydrogen (protium) electrode* corresponds to the conventional assumption of the zero standard entropy of H⁺ ions. This extra-thermodynamic assumption induces the impossibility of comparing the values referred to the hydrogen electrodes, in different solvents. The hydrogen electrode is used as the reference in collections of → *tabulated standard potentials* for aqueous solutions.

Refs.: [i] Inzelt G (2006) *Standard potentials*. In: Bard AJ, Stratmann M, Scholz F, Pickett CJ (eds) *Inorganic electrochemistry*. Encyclopedia of electrochemistry, vol. 7a. Wiley, Weinheim, chap 1; [ii] Parsons R (1974) *Pure Appl Chem* 37:503

GT, OP

Tabulated standard potentials — The → *standard potential* of various redox couples have been tabulated by using either the values obtained in electrochemical experiments or calculated from thermochemical data. The electrochemical determination of these values based on → *emf* measurements is possible provided that → *diffusion potentials* and thermo *emf*'s are elimi-

nated. As a lot of systems cannot be experimentally arranged under standard conditions, the values computed from other types of thermodynamic data are typically tabulated. The most famous reliable collections can be found in [i–vii], the latest collections being critically selected. The potentials of redox systems with participation of radicals and species in excited electronic states are discussed in [viii, ix]. There is no need to measure the potentials for all redox-pairs: if the partial values for a number of ions and compounds are known, the characteristic values for any other reactions can be computed (see → *Luther's rule*). This is of great importance for systems for which it is impossible, or extremely difficult, to prepare a reversible electrode (redox couples containing oxygen, or active metals, or solvated electron). The ordered series of tabulated standard potentials is also referred to as **electromotive series, electrochemical electromotive series, standard electrode potential series, and potential series**.

Refs.: [i] Latimer WM (1952) *Oxidation potentials*. Prentice-Hall, Englewood Cliffs; [ii] Parsons R (1985) *Redox potentials in aqueous solutions: a selective and critical source book*. Marcel Dekker, New York; [iii] Bard AJ, Parsons R, Jordan J (1985) *Standard potentials in aqueous solutions*. Marcel Dekker, New York; [iv] Antelman MS, Harris FJ (eds) (1982) *The encyclopedia of chemical electrode potentials*. Plenum Press, New York; [v] Pourbaix M (1963) *Atlas d'équilibres électrochimiques*. Gauthier-Villars, Paris; [vi] Bratsch SG (1989) *J Phys Chem Ref Data* 18:1; [vii] Inzelt G (2006) *Standard potentials*. In: Bard AJ, Stratmann M, Scholz F, Pickett CJ (eds) *Inorganic electrochemistry*. Encyclopedia of electrochemistry, vol. 7a. Wiley-VCH, Weinheim, chap 1; [viii] Stanbury DM (1989) In: Sykes AG (ed) *Advances in inorganic chemistry*, vol. 33. Academic Press, New York, p 69; [ix] Wayner D, Parker VD (1993) *Acc Chem Res* 26:287

GT, OP

Step potential — is the value the potential is stepped in various → *potential step techniques*, including multistep versions (→ *chronoamperometry*), as well as for the potential ramp in → *voltammetry*.

GT

Stripping potential — is the value of potential for stripping the initially accumulated reagent from the electrode surface or from an amalgam using stripping voltammetry. See → *adsorptive stripping voltammetry*, → *anodic stripping voltammetry*, → *cathodic stripping voltammetry*.

GT

Surface electric (phase boundary) potential — χ^α represents the electrical energy necessary to transfer the probe between two points located in different contacting phases. See → *inner (or internal) electric potential*. The surface potential of a liquid phase is dictated

by a certain interfacial orientation of solvent dipoles and other molecules with inherent and induced dipole moments, and also of ions and surface-active solute molecules. For solid phases, it is associated with the electronic gas, which expands beyond the lattice (and also causes the formation of a dipolar layer); other reasons are possible. The location of these probe points depends on the nature of surface potential, they should be distant enough from the conditional geometric surface to find themselves outside the specific near-surface regions mentioned above. Various attempts to give model estimates of the surface potential provide a lot of disagreement. Namely, for the water/air interface values from -0.48 up to $+0.29$ V can be found. A critical comparative consideration of various studies leads to a conclusion about a low positive value of, namely, 0.13 V [i–iii] for infinite dilution. The estimation of χ^α is still an unsolved theoretical problem closely related to the problem of the → *absolute potential*. This interfacial potential drop is a topical problem for modern studies of electrified interfaces on the microscopic level, particularly, in attempts of testing the electrified interfaces by probe techniques [iv, v].

Refs.: [i] Frumkin AN (1979) *Potentsialy nulevogo zaryada (in Russian) (Potentials of zero charge)*. Nauka, Moscow; [ii] Parsons R (1954) *Equilibrium properties of electrified interphases*. In: Bockris JO'M (ed) *Modern aspects of electrochemistry*, vol. 1. Butterworth, London, p 103; [iii] Trasatti S (1975) *J Electroanal Chem* 66:155; [iv] Hillier AC, Kim S, Bard AJ (1996) *J Phys Chem* 100:18808; [v] Thomas RC, Tangyonyong P, Houston JE, Michalske TA, Crooks RM (1994) *J Phys Chem* 98:4493

GT, OP

Underpotential deposition (upd) — refers to the deposition of atoms (so-called **adatoms**) on foreign metal supports at potentials that are more positive (if the adatom is the reduced form) or more negative (if the adatom is the oxidized form) as compared to potentials predicted by the → *Nernst equation* for bulk deposition. The earliest observations correspond to experiments on metal deposition from solutions of radioactive metal ions [i] and to the observation of hydrogen and oxygen upd on platinum group metals [ii]. Similar observations were later made for several dozens of support–foreign atom combinations, and the dependencies of the surface coverage by adatoms on solution composition and → *electrode potential* were reported. Qualitatively the phenomenon was explained by contribution of support–adatom interaction energy to the → *free energy* of the reduced or oxidized species forming partly or completely charged foreign atoms in submonolayers. Correlations with → *work functions* and phenomenological consideration of upd can be found in earlier re-

views [iii, iv]. Starting from the 1990s, an atomic level understanding was achieved due to the fast progress of single crystal electrochemistry, in situ spectroscopic techniques, and probe microscopy [v]. The principal types of adatomic layers were documented, including island-like layers and bilayered systems. Simultaneously, the coadsorption of adatoms with solvent molecules and ions was evidenced and became a special field in computational electrochemistry. The studies of upd are closely related to \rightarrow *electrocatalysis* [vi] in the context of surface modification by adatoms. Their role is typically to provide surface bifunctionality, or to support the formation of specific reaction sites, or (in contrast) to exclude the existence of sites suitable for the formation of catalytic poison (so-called third body effect). Special classification related to bifunctional electrocatalysis divides the reduced adatoms into oxygen-adsorbing and oxygen-nonsorbing adatoms.

See also the main entry \rightarrow *underpotential deposition*.

Refs.: [i] Haissinsky M (1933) *J Chim Phys* 30:27; [ii] Frumkin AN (1934) *Zh Fiz Khimii* 5:240; [iii] Kolb DM (1978) *Physical and electrochemical properties of metal monolayers on metallic substrates*. In: Gerischer H, Tobias CW (eds) *Advances in electrochemistry and electrochemical engineering*, vol. 11. Wiley, New York, p 125; [iv] Conway B (1984) *Progr Surf Sci* 16:1; [v] Ye S, Uosaki K (2003) *Atomically controlled electrochemical deposition and dissolution of noble metals*. In: Bard AJ, Stratmann M, Gileadi E, Urbakh M (eds) *Thermodynamics and electrified interfaces. Encyclopedia of electrochemistry*, vol. 1. Wiley-VCH, p 471; [vi] Adzic R (2003) *Electrocatalysis on surfaces modified by metal monolayers deposited at underpotentials*. In: Bard AJ, Stratmann M, Gileadi E, Urbakh M (eds) *Thermodynamics and electrified interfaces. Encyclopedia of electrochemistry*, vol. 1. Wiley-VCH, p 561

GT, OP

Volta potential difference (or contact potential)

— represents the potential differences between two points just outside the phases α and β in vacuum. It is a measurable quantity (see details in \rightarrow *outer electric potential*), because the points between which it is measured are located in one and the same phase and in the field of long-range forces exclusively. This means that the Volta potential does not depend on the charge of the probe. For the metal|metal boundary ($M_1|M$), this potential difference ($\Delta_M^{M_1}\psi$) can be defined by the difference of \rightarrow *work functions* [i]. The latter can be obtained from photoelectron emission (or thermoelectron emission), and also directly by using a circuit $M_1|M|vacuum|M_1$, where M_1 is the reference metal. The main experimental problems are the surface pretreatment (purification) and the elimination of the potential drop between the samples of M_1 and M in ultra-high vacuum. When the excess surface charge density of two metals in solution

is zero, the ionic double layers are absent on their surfaces, and the difference of electrode potentials is close to $\Delta_M^{M_1}\psi$. This is Frumkin's solution [ii] of the famous Volta problem of the nature of the \rightarrow *emf* of an electrochemical circuit. The Volta potential difference for the liquid metal|solution interface can be determined by using the following cell: reference electrode|solution|inert gas|Hg|solution|reference electrode, when the solution flows to the system through the internal walls of a vertical tube, where metal (e.g., mercury) flows out via a capillary placed axially in a vertical tube and is dispersed into drops. These metal drops carry away the free charges, thus, eliminating the potential difference in inert gas between the metal and the solution. A similar technique can be used for the solution|solution interface. There are also other techniques to determine the Volta potential difference [ii–v].

Refs.: [i] Schottky W, Rothe H (1928) *Physik der Glühelktroden*. In: Wien W, Harms F, Lenz H (eds) *Handbuch der experimentellen Physik*, vol. 13. Akademie Verlag, Leipzig, p 145; [ii] Frumkin AN (1928) *Ergeb exakt Naturwiss* 7:235; [iii] Frumkin A, Gorodetzkaja A (1928) *Z phys Chem* 136:215; [iv] Parsons R (1954) *Equilibrium properties of electrified interphases*. In: Bockris JO'M (ed) *Modern aspects of electrochemistry*, vol. 1. Butterworth, London, p 103; [v] Temkin MI (1946) *Bull Acad Sci URSS* No2:235

GT, OP

Zeta potential — The electrical \rightarrow *potential* difference between the bulk solution and the “shear plane” or outer limit of the rigid part of the double layer (the limits of the diffuse \rightarrow *double layer*) is the “electrokinetic potential”, often called the Zeta potential ζ (or more precisely the Zeta potential difference ζ).

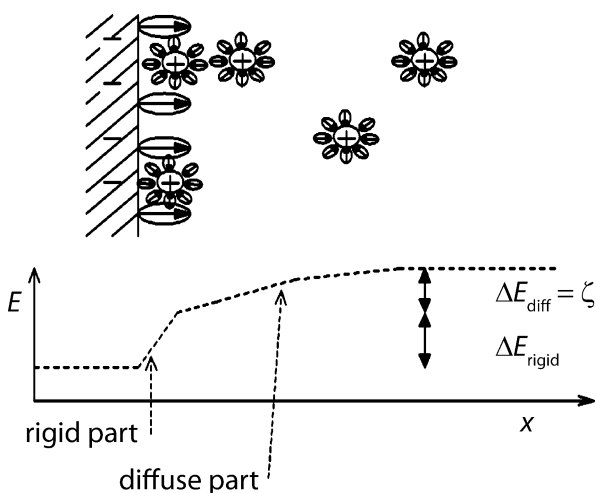

Potential — Zeta potential — Figure

The thickness of the diffuse part of the double layer depends directly on the \rightarrow ionic strength I . In dilute solutions the thickness can be about 10 nm, already at $c = 0.1 \text{ mol dm}^{-3}$ it is below 1 nm, i.e., about equal the thickness of the rigid part. At even higher concentrations the diffuse part of the double layer becomes negligibly thin.
 Ref.: [i] Hunter RJ (2001) *Foundations of colloid science*. Oxford University Press, Oxford

RH

Potentiodynamic electrochemical impedance spectroscopy (PDEIS) — is a technique that combines \rightarrow DC voltammetry with a multi-frequency version of \rightarrow AC voltammetry. PDEIS gives a set of electrochemical impedance spectra (\rightarrow electrochemical impedance spectroscopy) (measured in the course of a single potential scan) along with a conventional potentiodynamic \rightarrow voltammogram. Analysis of the \rightarrow impedance dependence on the AC frequency and \rightarrow electrode potential gives an \rightarrow equivalent circuit, with parameters that are functions of the potential, so that the ac responses of different interrelated interfacial processes (\rightarrow charge transfer, \rightarrow diffusion, \rightarrow adsorption, etc.) and interfacial structures (\rightarrow double layer, space charge layer, etc.) can be represented individually and further analyzed in terms of equivalent circuit parameters dependencies on the potential. This approach enables investigating the dynamics of interfacial structures (adsorption, atomic layer and multilayer formation, \rightarrow nucleation, film growth) and characterization of nonstationary semiconductor-electrolyte interface (PDEIS gives \rightarrow Mott-Schottky plot in a single scan, together with parameters of \rightarrow Faraday impedance). Unlike electrochemical impedance spectroscopy of stationary systems that uses a wide frequency interval, PDEIS has to limit the set of frequencies to a more narrow range, usually from two to three orders of magnitude, to comply with potentiodynamic conditions of spectra acquisition and to minimize the effect of a frequency dispersion of circuit parameters which hinders fitting of nonstationary data if those are measured in a wide range. Ambiguities related to the possibility to fit the data to several different equivalent circuits are resolved in PDEIS by analyzing equivalent circuit parameters and errors of their calculation as functions of the potential. Contributions of different elements of the circuits to the impedance depend differently on the potential, and this enables an easy recognition and exclusion of faulty equivalent circuits, so that the narrowed frequency range gives more advantages than disadvantages.

During the spectra acquisition, the electrode potential is controlled by a computer program (a virtual

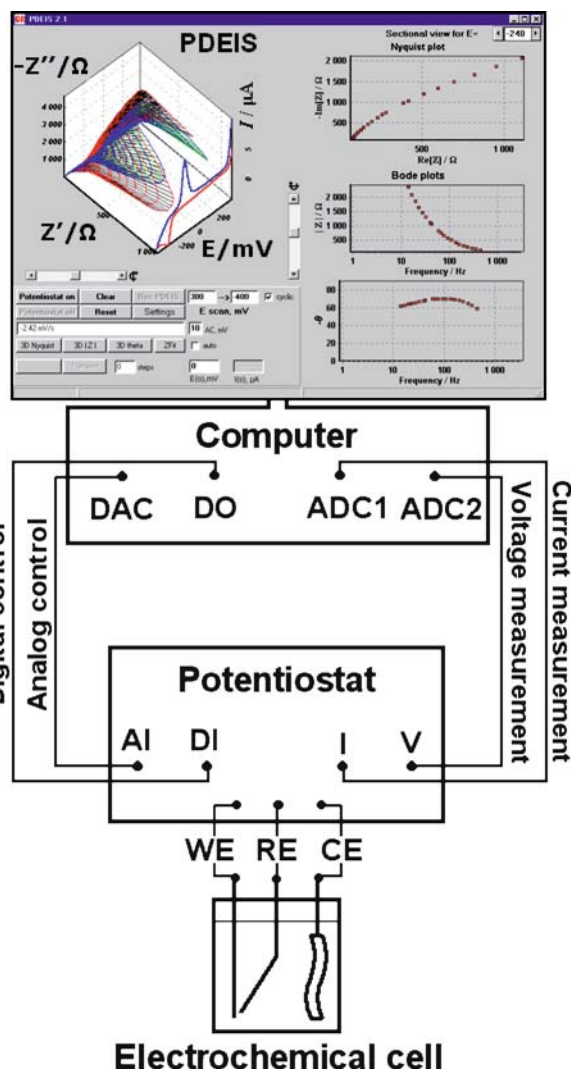

Potentiodynamic electrochemical impedance spectroscopy (PDEIS) — Figure. Diagram of potentiodynamic electrochemical impedance spectroscopy experimental setup

impedance spectrometer) by means of a \rightarrow potentiostat interfaced to a computer with \rightarrow analog-to-digital converters (ADC), \rightarrow digital-to-analog converters (DAC), and also a digital channel (Figure). The waveform of the probing signal is generated by a DAC and can be different in different versions. The prototype of the potentiodynamic multi-frequency AC probing [i] uses a mixture of many frequencies applied simultaneously, while the present version of PDEIS [ii, iii] uses separate probing in each frequency implemented with sequences of low-amplitude wavelets, in order to minimize inter-frequency interference in investigation of fast-varying nonstationary systems. The AC waveform is superim-

posed onto a quasilinear staircase potential ramp. The virtual impedance spectrometer compares potential and current variations, acquired by two ADC's, calculates impedance spectra in real time and presents the 3D potentiodynamic spectrum (impedance spectra dependence on the potential) and a voltammogram on the computer screen. The backward scan gives another 3D spectrum that generally differs from the first one but the spectra coincide for a perfectly reversible system. Analysis of both spectra enables characterization of deviations from reversible behavior separately for each of the equivalent circuit elements.

Refs.: [i] Schwall RJ, Bond AM, Loyd RJ, Larsen JG, Smith DE (1977) *Anal Chem* 49:1797; [ii] Ragoisha GA, Bondarenko AS (2005) *Electrochim Acta* 50:1553; [iii] Ragoisha GA, Bondarenko AS (2005) *Potentiodynamic electrochemical impedance spectroscopy*. In: Nunez M (ed) *Electrochemistry: new research*. Nova Science Publ, New York, chap 3

GR

Potentiodynamic techniques — are all those techniques in which a time-dependent \rightarrow potential is applied to an \rightarrow electrode and the current response is measured. They form the largest and most important group of techniques used for fundamental electrochemical studies (see \rightarrow electrochemistry), \rightarrow corrosion studies, and in \rightarrow electroanalysis, \rightarrow battery research, etc. See also the following special potentiodynamic techniques: \rightarrow AC voltammetry, \rightarrow DC voltammetry, \rightarrow cyclic voltammetry, \rightarrow linear scan voltammetry, \rightarrow polarography, \rightarrow pulse voltammetry, \rightarrow reverse pulse voltammetry, \rightarrow differential pulse voltammetry, \rightarrow potentiodynamic electrochemical impedance spectroscopy, \rightarrow faradaic rectification voltammetry, \rightarrow square-wave voltammetry.

FS

Potentiometric sensors \rightarrow Electrochemical sensors for which the \rightarrow potential of the \rightarrow indicator electrode is measured against a \rightarrow reference electrode. The commonly used \rightarrow pH-sensitive electrodes and \rightarrow ion-selective electrodes belong to the group of potentiometric sensors. See also \rightarrow potentiometry.

Ref.: [i] Janata J (1989) *Principles of chemical sensors*. Plenum, New York; [ii] Hulanicki A, Glab S, Ingman F (1991) *Pure Appl Chem* 63:1247

JB

Potentiometric stripping — is an electroanalytical approach to determine the concentration of ions in solution. It is based on a two-step approach: preconcentration and analysis. In the first step, a known amount of the oxidizing agent (usually Hg^{2+}) is added to the sample and electrochemically reduced, thus forming a layer of

mercury on the electrode substrate. During that step, the \rightarrow analyte ions are simultaneously reduced and dissolved (preconcentrated) in the mercury layer. In the analysis step, the potentiostat is switched off, i.e., the system operates under open-circuit conditions, and the electrode potential is determined by potentials of the redox couples formed by the analyte metals (present in mercury) and their ions, which are formed by the oxidation of the deposited metal, e.g., by Hg^{2+} , by dissolved oxygen or other oxidants. When a few metals are determined, they are oxidized one by one, in the order of their growing redox potentials, during periods of time that are proportional to the concentration of a given metal in the mercury layer. Typical responses (so-called stripping potentiograms) show S-shaped staircase-type curves of potential as a function of time. Frequently, the first derivative is displayed ($dE/dt = f(t)$), as this produces peak-shaped signals.

Potentiometric stripping can be regarded as \rightarrow chronopotentiometry under open-circuit conditions (\rightarrow open-circuit potential) with chemical oxidation of preliminarily deposited metals.

By analogy to \rightarrow stripping voltammetry, low detection limits (below 10^{-6} mol L $^{-1}$) can be achieved as a result of the preconcentration step in which the analyte ions from solution are reduced and dissolved in a small volume of the mercury film. To maximize effectiveness of the ion transfer rate during the preconcentration step, the solution is usually stirred or the electrode is rotated; alternatively, flow cells can be used. Among important problems is a danger of the formation of complex intermetallic compounds by certain analyte metals (e.g., by Cu or Mn) with mercury that are characterized by different redox potentials. To achieve good reproducibility, the preconcentration step conditions must be strictly controlled during multiple determinations. The selectivity depends on the choice of the potential applied during the preconcentration step and on the degree of separation of the analyte metals' redox potentials.

The electrode substrates typically considered for potentiometric stripping analysis are \rightarrow glassy carbon and wax-impregnated graphite. Application of metal substrates is usually limited due to the possibility of contamination of mercury by amalgamation. Also other intermetallic compounds can be formed. Very careful polishing is essential to obtain good results.

Potentiometric stripping can be used for simultaneous determination of metals (out of Pb, Cd, Tl, Na, K, Ca, Sr, Ba, Mg, Sn, Bi, Cu) in many complex samples such as wine, whole blood or serum, and groundwater.

Refs.: [i] Heineman WR, Mark HB, Wise JA, Roston DA (1984) *Electrochemical preconcentration*. In: Kissinger PT, Heineman WR (eds) *Laboratory techniques in electroanalytical chemistry*. Marcel Dekker, New York; [ii] Wang J (2000) *Analytical electrochemistry*, 2nd edn. VCH, Weinheim

PK, AL

Potentiometric titration — A \rightarrow titration method based on the measurement of the potential of a suitable \rightarrow indicator electrode as a function of \rightarrow titrant volume. Usually the \rightarrow cell voltage or a \rightarrow *p*-function associated with the concentration of the \rightarrow analyte is plotted as a function of the volume of \rightarrow titrant added [i]. See also \rightarrow differential potentiometric titration, and \rightarrow retarded electrode.

Ref.: [i] Skoog D, West D, Holler F (1996) *Fundamentals of analytical chemistry*. Saunders College Publishing, New York

FG

P

Potentiometry — In this electrochemical method the \rightarrow potential difference between an \rightarrow indicator electrode and a \rightarrow reference electrode is measured. Usually, this is made under \rightarrow equilibrium conditions, which means that the concentrations of all species are uniform throughout the solution. Lest the potential would be affected, voltage meters with high input \rightarrow impedance are used, so that the current flowing through the cell is as small as possible. The analytical application of potentiometry is based on the proportionality between the potential of indicator electrode and the logarithm of activity of some ions, or molecules. The indicator and reference \rightarrow half-cells are separated by a \rightarrow salt bridge. The potential of the reference electrode is constant and independent of the composition of \rightarrow electrolyte in the indicator half-cell. The indicator electrodes or \rightarrow sensors are either metal \rightarrow electrodes of the first kind (e.g., Ag|Ag⁺), the \rightarrow second kind (e.g., Ag|AgCl|Cl⁻), or the \rightarrow third kind (e.g., Ag|Ag₂S|CuS), or \rightarrow redox electrodes (e.g., Pt|Fe³⁺, Fe²⁺), or \rightarrow membrane electrodes. In equilibrium, the potential of the metal and redox electrodes is defined by the \rightarrow Nernst equation. These sensors are used in potentiometric titrations and for direct potentiometric determinations. The following \rightarrow ion-selective electrodes are of special importance [i, ii]:

1. \rightarrow Glass electrodes, which are selective for cations such as H⁺, Na⁺, and NH₄⁺.
2. Electrodes with sparingly soluble inorganic salt membranes which are made of either a section of a single crystal such as LaF₃, or a pressed powder of salts such as Ag₂S/AgCl mixture, metal chalcogenides, etc. They are selective for anions, like F⁻,

S²⁻, and Cl⁻, and many metal ions, such as Ag⁺, Pb²⁺, and Cu²⁺.

3. Electrodes with membranes in which an ion-selective complexing agent, or ion exchanger is immobilized in a polymer matrix. They are selective for Ca²⁺, K⁺, NO₃⁻, and many other ionic species.
4. Electrodes with enzymes (e.g., urease) incorporated into a gel membrane. They are selective for biochemical compounds such as urea, glucose, L-amino acids, and penicillin (see \rightarrow biosensors).

With these sensors the concentrations of ions or molecules are determined from the calibration graphs.

Many \rightarrow gas sensors based on \rightarrow solid electrolytes operate under potentiometric conditions [iii]. The sensors for oxygen use oxide \rightarrow conductors, such as ZrO₂-based ceramic, those for halogens use halide conductors (e.g., KAg₄I₅), while \rightarrow hydrogen sensors use protonic conductors. There are sensors for CO₂, NO₂, NH₃, SO₃, H₂S, HCN, HF, etc. (see \rightarrow lambda probe).

In some cases, potentiometry can also be performed with electrodes at which a \rightarrow mixed potential is measured. In these cases careful calibration is needed, or the electrodes are only used to monitor the equivalence point of titration by providing a certain characteristic inflection point *f*.

See also \rightarrow chronopotentiometry.

Refs.: [i] Cattrall RW (1997) *Chemical sensors*. Oxford University Press, Oxford; [ii] Kahlert H (2002) *Potentiometry*. In: Scholz F (ed) *Electroanalytical methods*. Springer, Berlin, p 223; [iii] Fabry P, Siebert E (1997) *Electrochemical sensors*. In: Gellings PJ, Bouwmeester HJM (eds) *The CRC handbook of solid state electrochemistry*. CRC Press, Boca Raton, p 329

MLo

Potentiostat — A potentiostat is an electronic amplifier which controls the potential drop between an electrode (the \rightarrow working electrode, (WE)) and the \rightarrow electrolyte. The WE is normally connected to ground potential; the potential of the electrolyte is measured by a special probe, the \rightarrow reference electrode (RE). Effects of the \rightarrow counter electrode (CE), (e.g., potential drop at the CE|electrolyte interface) and the electrolyte (esp. the solution resistance) can be suppressed by this technique. Potentiostats are based on \rightarrow operational amplifiers (OPA); the simplest circuit is given in Fig (a). The difference between the desired potential U_d and the reference electrode potential U_{RE} is amplified, resulting in currents via counter and working electrode until this difference becomes (almost) zero.

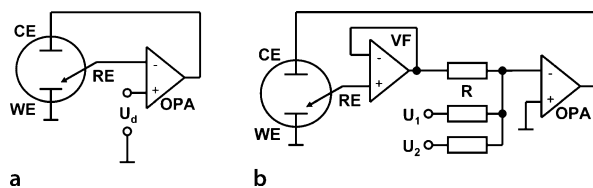

Potentiostat — Figure

A different design, an adder potentiostat, is shown in Fig. (1b). The RE is buffered by a voltage follower (VF) and separate input signals U_1, U_2, \dots such as rectangular pulses, ramps, or sine waves can be mixed. Similarly, U_d in Fig. (1a) can be composed of several signals by an adder circuit (not shown).

A potentiostat as a laboratory device is normally equipped with further features such as monitoring of the \rightarrow reference electrode, current detection by current-to-voltage-converters, or differential amplifiers, pulse form generators, displays of current and potential, and computer interfaces. See also $\rightarrow IR_u$ potential drop and $\rightarrow IR$ drop compensation, \rightarrow Randles.

Ref.: [i] Bard AJ, Faulkner LR (2001) *Electrochemical methods*, 2nd edn. Wiley, New York

MML

Potentiostatic circuit — The potentiostatic circuit consists of the electrochemical cell with three electrodes (\rightarrow working electrode WE, \rightarrow reference electrode RE, and \rightarrow counter electrode CE) and a special electronic amplifier, the \rightarrow potentiostat.

The electrochemical cell is represented by the resistance R_{WE} of the interface WE|electrolyte, the resistance R_{Ohm} of the electrolyte between the WE and tip of the RE, the resistance R_{El} of the electrolyte between the tip of the RE and the CE, the resistance R_{CE} of the interface electrolyte|CE, and the inner (source) resistance R_{RE} of the reference electrode. R_{other} represents the sum of resistances outside the cell, e.g., the output resistance of the amplifier, any resistances resulting from current monitoring and cables. The potentiostat amplifies the difference $U_+ - U_-$ by a factor A in the range from 10^4 to 10^7 :

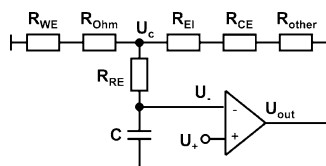

Potentiostatic circuit — Figure

$U_{out} = \Delta U \cdot A$. The potential U_c at the tip of the RE depends on $U_{out} = \frac{R_{WE} + R_{Ohm} + R_{El} + R_{CE} + R_{other}}{R_{WE} + R_{Ohm}} U_c$. If $U_- \approx U_c$ (which is true for an ideal amplifier input) the deviation of the cell potential U_c from the desired value U_+ is given by $U_+ - U_c = \frac{R_{WE} + R_{Ohm} + R_{El} + R_{CE} + R_{other}}{A \cdot (R_{WE} + R_{Ohm})} U_c$. This error is smaller than 1 mV under common conditions. A more precise analysis has to respect that some of the resistances are time-, frequency-, and potential-dependent, especially R_{WE} and R_{CE} .

Further problems arise from the source resistance R_{RE} of the reference electrode. This resistance is typically in the range from 1 k Ω to 10 M Ω and – together with the input capacity C of the inverting input of the amplifier (typically 20 pF) – results in a time constant $\tau = R_{RE}C$ which limits the high frequency response. Furthermore, real amplifiers send an unwanted small current, the so-called bias current, through the outer circuit. This current can be in the range of pA or even larger and induces an additional potential drop at R_{RE} . See also $\rightarrow IR_u$ (potential drop) and $\rightarrow IR$ drop compensation.

Ref.: [i] Bard AJ, Faulkner LR (2001) *Electrochemical methods*, 2nd edn. Wiley, New York

MML

Potentiostatic intermittent titration technique (PITT)

— Technique applied to measure the chemical \rightarrow diffusion coefficient of the intercalating species within insertion–host electrode materials with the help of an electrochemical cell, followed by the current response on the staircase potential signal that is recorded as current–time curve [i]. The theory of this technique is based on the equation of $D = \left[\frac{(I\sqrt{t})_{\max} \sqrt{\pi} R}{\Delta Q} \right]^2$, where D is the chemical diffusion coefficient; t is the measuring time during a small potential step; I is the response current; R is particle radius of insertion–host electrode materials; $\Delta Q = \int_{t=0}^{\infty} I(t) dt$, is the total charge transferred between initial and end potential when zero current is again achieved; $(I\sqrt{t})_{\max}$ is equal to the slope of tangent to $(I\sqrt{t})$ versus $1/\sqrt{t}$ curve going through the co-ordinate origin.

Ref.: [i] Wen CJ, Boukamp BA, Huggins RA, Weppner W (1979) *J Electrochem Soc* 126:2258

XCT

Potentiostatic techniques — In the strict sense, techniques in which the \rightarrow electrode potential is kept constant with the help of a \rightarrow potentiostat. The term, however, is also used for techniques in which the electrode potential is linearly or stepwise changed using a potentiostat.

FS

Pourbaix, Marcel

(Sep. 16, 1904, in Myshega, Russia – Sep. 28, 1998, Uccle, Brussels, Belgium) Pourbaix graduated from the Faculty of Applied Sciences of the Université Libre de Bruxelles in 1927. Following some years in industry he returned to this University in 1937. In 1938 he published for the first time \rightarrow *potential–pH diagrams* that are now known as \rightarrow *Pourbaix diagrams*. Pourbaix received two doctorates, one from the University of Delft, and one from Brussels. In 1949 he became a co-founder of the Comité International de Thermodynamique et Cinétique Electrochimiques (CITCE), which later became the \rightarrow *The International Society of Electrochemistry* (ISE). In addition to his graphical presentations of the thermodynamics of coupled redox and acid base equilibria, Pourbaix made various contributions to the understanding of \rightarrow *corrosion*.
 Refs.: [i] Staehle RW (1976) *J Electrochem Soc* 123:23c; [ii] <http://www.corrosion-doctors.org/Biographies/PourbaixBio.htm>; [iii] http://www.geocities.com/neveyaakov/electro_science/pourbaix.html

Pourbaix diagram \rightarrow *potential–pH diagram*

Power (electrical) — Power, in general, is defined as “the rate of energy transfer”. Electrical power is defined as the amount of work done by an electric \rightarrow *current* in a unit time. When a current flows in a circuit with a \rightarrow *resistance* element, it performs work. Devices can be made that convert this work into heat (electric heaters), light (light bulbs), motion, i.e., kinetic energy (electric motors), and others. Electrical power is calculated using Joule’s law, who first showed that electrical and mechanical energy were interchangeable. According to Joule’s law power is expressed in Watts (W) and calculated as the product of current and voltage: $P = UI$ (U in volt and I in ampere). In reactive circuits, where inductive and capacitive elements are present, periodic reversals of the direction of energy flow result. In such cases power is usually referred to as “real power”, which is defined as the time-averaged power over one complete cycle of

the AC wave, which results in the net transfer of energy in one direction. The portion of the power flow that returns to the source in each cycle due to stored energy in the reactive components is known as “reactive power”. “Apparent power” is the vector sum of the real power and the reactive power. In the realm of electrochemical power sources, such as \rightarrow *electrochemical cells*, \rightarrow *batteries*, \rightarrow *fuel cells*, etc., electrical power reflects the rate at which the power source can deliver their energy. The power of batteries depends on many factors, of which the most important ones are the \rightarrow *kinetics* of the electrode reactions, solution and membrane \rightarrow *impedance* and the battery configuration and design (internal resistance). Batteries using sintered electrodes will provide higher power than those using pressed electrodes due to the higher electrode surface area, which results in lower cell internal resistance.

The term power is also used to express the rate at which energy is delivered from \rightarrow *capacitors*, when they are used as power sources. Capacitors, and in particular the “double layer” type, are usually very high power suppliers due to the very fast kinetics of their discharge process. Therefore, although their energy density is low, the entire capacity can be delivered in a very short time interval. Some electrochemical capacitors (usually metal oxide or \rightarrow *conducting polymer* based) possess higher energy density but, due to the involvements of faradaic reactions during their discharge process, they show lower power compared to traditional, double-layer capacitors. Loads are also characterized by power rating, e.g., an electrical motor or a light bulb is characterized by the power conditions needed for its operation.

Refs.: [i] McNaught AD, Wilkinson A (eds) (1996) *IUPAC compendium of chemical terminology (gold book)*. Blackwell Scientific, Cambridge, p 987; [ii] Bockris JO’M, Reddy AKN (2000) *Modern electrochemistry*, 2nd edn. Springer, Kluwer Academic, New York, pp 1808–1810; [iii] Besenhard JO (1999) *Handbook of battery materials*. Wiley-VCH, New York, pp 14–15

OC

Power density — (specific power) The ratio between the power available from a \rightarrow *battery* to its weight or volume. The power density is expressed in watt per unit mass (usually $W\ kg^{-1}$) for gravimetric power density and in watt per unit volume (usually $W\ L^{-1}$) for volumetric power density. The power density of a battery is strongly depended on the cell configuration and design. In general, using electrodes with high surface area to volume ratio will enable higher power density. In addition, the obtained power density depends of the temperature and on the cycle number (in secondary batteries).

Refs.: [i] Linden D (1994) *Handbook of batteries*, 2nd edn. McGraw-Hill, New York, Appendix A; [ii] Dell RM, Rand DAJ (2001) *Understanding batteries*. Royal Society of Chemistry, p 25–30

OC

Power source — Power source produce and supply electrical energy by converting, mechanical, chemical or solar → *energy* into electricity. A mechanical power source is an electrical generator that is based on the movement of electric conductors (e.g., copper wires) in a magnetic field (or vice-versa). Consequently, electric current flows in the conductor as described by the electromagnetic induction rules of → *Faraday* (1831). In such way, the mechanical energy of the moving wire is converted into electric energy. The rotor that moves the conductors is turned by a prime mover, often a diesel engine, steam turbine, water turbine or gas turbine coupled to the rotor. Both ac (→ *alternating current*) and DC (→ *direct current*) currents can be produced by electric generators. Power sources that convert chemical energy into electricity are all types of → *batteries* and → *fuel cells*. These power sources use spontaneous electrochemical reactions as a source of electrical power. The cell voltage is determined by the potential difference of the battery electrodes (minus → *IR drop* [*R* being the inner resistance] when *I* is not zero). The battery voltage depends on the individual cell voltage and on the number of cells stacking in series in the battery. The 12 V → *lead-acid battery* that is commonly used in automobiles is composed of six 2 V cells in series. The currents drained from batteries and fuel cells are always DC currents. The power (currents) that can be delivered by the battery depends on the → *kinetics* of the electrochemical reaction, the internal → *resistance* of the battery, the design and configuration of the cell and the operation temperatures. There are two significant types of batteries, primary and secondary batteries. Primary batteries are usually capable of delivering low-current DC power and are not designed for recharging. Secondary batteries are designed for repetitive uses by recharging cycles. The applications and performance of secondary (rechargeable) batteries are strongly depended on their chemistry, design, and configuration. Fuel cells utilize oxygen from the air and hydrogen gas or fuel that are continuously supplied to the cell during its operation. The electrochemical reaction products are water and heat that are continuously removed from the cell. The efficiency of electrochemical processes and thus the available power density from fuel cells, strongly depend on the electrolyte used, on the type of hydrogen fuel, and on the temperature. Power sources that convert solar energy to electricity are named solar

cells or photovoltaic cells. A solar cell is a → *semiconductor* device (e.g., silicon) consisting of a large-area *p* – *n* junction diode which in the presence of light is capable of generating usable electrical energy. This conversion is called the photovoltaic effect (→ *photovoltaic device*). The efficiency of electricity production by photovoltaic cells is defined as the ratio of the maximum output electrical power divided by the input light power. The efficiency varies from 6–30%, depending mainly on the semiconductor used and on the input sunlight flux.

Refs.: [i] Chapman SJ (2004) *Electric machinery fundamentals*, 4th edn. McGraw-Hill, New York; [ii] Würfel P (2005) *Physics of solar cells*. Wiley-VCH, New York; [iii] Linden D (1994) *Handbook of batteries*, 2nd edn. McGraw-Hill, New York, p 1.3–5.16; [iv] Turner WC (2004) *Energy management handbook*, 5th edn. CRC Press, Boca Raton, p 170–193

OC

Power conversion efficiency — is the ratio between output power and input power of a device. In → *photovoltaic devices* it denotes the ratio between the maximum electrical power supplied by a device and the incident radiant power. In this case it is given by $\eta = \frac{U_{oc} \times J_{sc} \times FF}{E}$, where U_{oc} is the → *open-circuit potential*, J_{sc} is the → *short-circuit current density*, *FF* is the → *fill factor*, and *E* is the → *irradiance*.

Ref.: [i] Brabec CJ, Sariciftci NS (2000) *Conjugated polymer-based plastic solar cells*. In: Hadziioannou G, van Hutten PF (eds) *Semiconducting polymers - chemistry, physics and engineering*. Wiley-VCH, Weinheim

IH

Practical capacity (of batteries) → *capacity*

Prandtl boundary layer — This layer is formed in viscous fluids flowing along a solid wall. In close vicinity to the wall, a thin layer of fluid with lower velocity than the outer flow develops. Right at the surface the flow has zero relative speed because of the roughness of the surface on a molecular scale and because of the → *van der Waals forces* between the molecules of the fluid and the wall. This fluid transfers momentum to adjacent layers through the action of viscosity. Thus, a fluid velocity gradient is formed at right angle to the surface of the solid wall, with velocities ranging from that of the flow of the bulk of the fluid to zero at the wall. The thickness of this boundary layer is given by the relationship: $\delta_0 \approx L/\sqrt{Re}$, where *L* is the length of the surface in the direction of the flow, $Re = vL/\nu$ is the → *Reynolds number*, *v* is the velocity of the flow, and ν is the coefficient of kinematic → *viscosity*. At the → *rotating disk*, the thickness of the Prandtl boundary layer depends on the rotation rate ω of the disk: $\delta_0 = 3.6\sqrt{\nu/\omega}$. Thickness δ_0 is identical over

the entire surface of the disk. The boundary layer concept was developed by the German physicist and engineer Ludwig Prandtl (1875–1953) who discovered in 1904 the importance of the → *hydrodynamic boundary layer* and developed its theory.

Ref.: [i] Levich VG (1962) *Physicochemical hydrodynamics*. Prentice-Hall, Englewood Cliffs

MLo

Pre-association — is a step on the reaction path of some stepwise reactions in which the → *molecular entity* C is already present in an encounter pair or → *encounter complex* with A during the formation of B from A, e.g.,

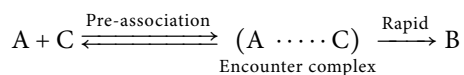

In this mechanism the → *chemical species* C may but does not necessarily assist the formation of B from A, which may itself be a bimolecular reaction with some other reagent.

Pre-association is important when B is living too short in order to permit B and C to come together.

Ref.: [i] Muller P (1994) *Pure Appl Chem* 66:1077

WK

Preceding chemical reactions in electrochemistry
→ *chemical reactions in electrochemistry*

Precipitation — The formation of a solid in a solution during a chemical reaction or from a solution that has been oversaturated by a compound [i]. See also → *oversaturation*, → *nucleation*, → *nucleation and growth kinetics*.

Ref.: [i] Harris D (2002) *Quantitative chemical analysis*. WH Freeman, New York

FG

Precipitation titrimetry — A method for the → *titration* of species by a → *precipitation* reaction. Commonly, the → *end point* of precipitation reactions is monitored by chemical, potentiometric or amperometric methods. A chemical method involves an → *indicator* that usually has a change in color at the → *end point*, while the other methods can be implemented as a → *potentiometric titration* or → *amperometric titration*, respectively. An important precipitating reagent is silver nitrate, i.e., silver ions Ag⁺. Such titrations are called argentometric titrations [i], and silver → *electrodes* are useful as → *indicator electrodes*.

Ref.: [i] Skoog D, West D, Holler F, Crouch SR (2003) *Fundamentals of analytical chemistry*. 8th edn. Brooks/Cole, Belmont

FG

Precision — The closeness between data that have been obtained from multiple samplings of a homogeneous sample studied under stipulated conditions of measurement. The smaller the random → *error* of a measurement, the more precise is the procedure. The precision of a measurement can be characterized by the → *standard deviation* [i].

Ref.: [i] IUPAC (1997) *Compendium of Chemical Terminology*

FG

Preconcentration — The use of preconcentration steps in electroanalysis (→ *electroanalytical chemistry*) has been the basis for the most sensitive electroanalytical methods. It is a great advantage of the latter that the preconcentration can be performed in situ at the electrode surface where later the analytical signal will be generated. The preconcentration can be a reductive deposition of metals from metal ion solutions (in → *anodic stripping voltammetry*), it can be an oxidative deposition of oxides (e.g., PbO₂, iron(III) oxide-hydrate, manganese(IV)-oxide (in → *cathodic stripping voltammetry*), the formation of sparingly soluble salts with the electrode material, (e.g., calomel Hg₂Cl₂ upon oxidation of the mercury electrode in a chloride solution, etc.) (in → *cathodic stripping voltammetry*), and it can be the adsorption of organic compounds (in → *adsorptive stripping voltammetry*). Since the determination step consists after all these preconcentration steps in a stripping off of the deposited species, these methods are summarized under the term → *stripping voltammetry*, with the variants anodic s. v., cathodic s. v., and adsorptive s. v. Here, anodic and cathodic refer to the determination step, and adsorptive refers to the preconcentration step [i–iv]. Occasionally, the preconcentration step may be a gas–solid reaction, e.g., the trapping of mercury vapor on gold electrodes [v], or the reaction of elementary halogens [vi] or of H₂S with a silver electrode [vii]. The effect of preconcentration with respect to increasing the sensitivity of an electroanalytical technique can be further enhanced by coupling it to a → *catalytic current*.

Refs.: [i] Wang J (1994) *Analytical electrochemistry*. VCH, New York; [ii] Lovrić M (2005) *Stripping voltammetry*. In: Scholz F (ed) *Electroanalytical methods*. Springer, Berlin, pp 191; [iii] Vydra F, Štulík K, Julakova E (1976) *Electrochemical stripping analysis*. Ellis Horwood, Chichester; [iv] Brainina K, Neyman E (1993) *Electroanalytical stripping methods*. Wiley, New York; [v] Scholz F, Nitschke L, Henrion G (1987) *Anal Chim Acta* 199:167; [vii] Scholz F, Nitschke L, Henrion G (1987) *J Electroanal Chem* 224:303; [vii] Scholz F, Nitschke L, Henrion G (1987) *Z Chem* 27:305

FS

Precursor complex → *encounter complex*

Pre-equilibrium (or prior equilibrium) — is a rapidly reversible step preceding the rate-limiting step in a step-wise reaction. For example

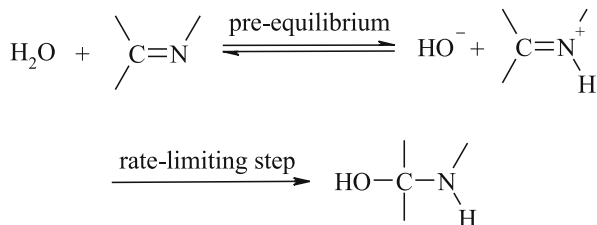

Pre-equilibrium (or prior equilibrium) — **Figure**

Pre-equilibria are important for kinetic currents (see → *current*, subentry → *kinetic limiting current*.)

Ref.: [i] Muller P (1994) *Pure Appl Chem* 66:1077

WK

Pre-exponential factor → *Arrhenius equation*

Pre-wave — In DC → *polarography*, this is a part of the response of fast and reversible electrode reaction (→ *reversibility*) complicated by the → *adsorption* of product on the → *dropping mercury electrode* surface: $\text{Ox} + n e^- \rightleftharpoons (\text{Red})_{\text{ads}} \rightleftharpoons \text{Red}$, assuming that the reactant Ox is only present in the bulk of the solution. The adsorption stabilizes the product and facilitates the reduction, so the adsorption wave appears at higher potential than the main wave. If the electrode surface is totally covered by the adsorbed product before the end

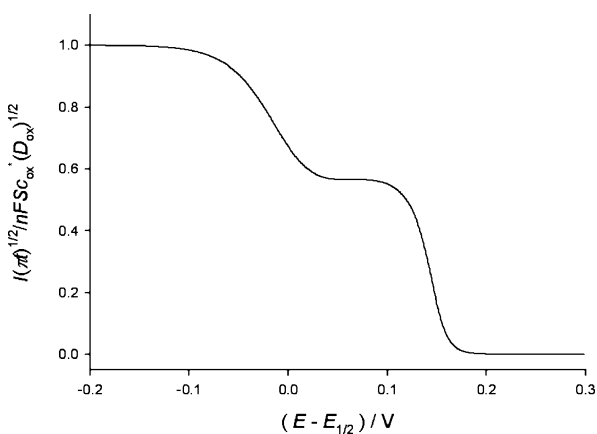

Pre-wave — **Figure**. A pre-wave and a main-wave in DC polarography

of its life-time, a main wave corresponding to a simple reaction $\text{Ox} + n e^- \rightleftharpoons \text{Red}$ appears after the adsorption wave, which is for this reason called the pre-wave (see the Figure). A difference between → *half-wave potentials* of the pre-wave and main wave is proportional to the strength of adsorption. These two waves may be merged into a single wave if the adsorption is weak, but if its strength is enhanced by the lateral attraction in the adsorbed layer, they can be separated by a minimum. A well-defined → *limiting current* of the pre-wave, parallel to the limiting current of the main wave, may appear under special experimental conditions. At short drop life-time and low reactant concentrations the pre-wave prevails, while at long drop lifetimes and high reactant concentrations the main wave dominates the total response. For constant drop lifetime, the limiting current of the pre-wave increases proportionally to the reactant concentration until a certain critical value, after which it stagnates and the main wave develops.

The opposite of the pre-wave is a post-wave, which is a consequence of the adsorption of reactant on the electrode surface: $\text{Ox} \rightleftharpoons (\text{Ox})_{\text{ads}} + n e^- \rightleftharpoons \text{Red}$. As the reactant is stabilized by the adsorption, an additional energy is needed for its reduction and the adsorption wave appears at lower potentials than the main wave. After the saturation of the electrode surface, the main wave appears before the adsorption wave, so the latter is called the post-wave. The total response depends on the reactant concentration, the drop life-time and the parameters of the adsorption isotherm similarly as in the case of product adsorption.

If both the reactant and product are adsorbed on the electrode surface, the pre-wave appears if the adsorption of product is stronger than the adsorption of reactant, while the post-wave appears in the opposite case. If the adsorptions of both the reactant and product are equally strong, only a main wave can appear, but this is a simplification which neglects possible interactions between molecules in the first and second adsorbed layers.

In → *cyclic voltammetry* the pre-peak and the post-peak correspond to the pre-wave and the post-wave in the polarography.

Ref.: [i] Heyrovsky J, Kuta J (1966) *Principles of polarography*. Academic Press, New York

ŠKL

Prigogine, Ilya



© The Nobel Foundation

(Jan. 25, 1917, Moscow, Russia – May 28, 2003, Brussels, Belgium) Ilya Prigogine studied chemistry and physics at the Université Libre de Bruxelles, where he completed his PhD in 1941, and became a professor in 1947. He joined the Brussels → *thermodynamics* school founded by Théophile De Donder (1873–1957) and Jean Timmermans (1882–1971). He received the Nobel Prize in Chemistry in 1977 for his contributions to nonequilibrium thermodynamics, particularly the theory of dissipative structure. His work established a thermodynamic basis of → *transport phenomena* in → *electrolyte solutions* and → *electrochemical oscillations*.

Refs.: [i] Prigogine I-Autobiography: <http://nobelprize.org/chemistry/laureates/1977/prigogine>; [ii] Prigogine I (1967) *Introduction to the thermodynamics of irreversible processes*. Wiley Interscience, New York; [iii] Prigogine I (1962) *Non-equilibrium statistical mechanics*. Wiley Interscience, New York; [iv] Glansdorff P, Prigogine I (1971) *Thermodynamic theory of structure stability and fluctuations*. Wiley, London

GI

Primary battery → *battery*, → *galvanic cell*

Primary cell → *battery*, → *galvanic cell*

Primary current distribution → *current density*

Primary standard — (*in titrimetry*) A highly purified and chemically stable reagent that can be dissolved in the solvent of choice to serve as reference material for the → *titration* of a proper → *analyte*. A primary standard reagent must react rapidly, completely, and stoichiometrically with the → *analyte*, as well as having a reasonably large molar mass [i].

Ref.: [i] Mendham J, Denney R, Barnes J, Thomas M (2000) *Vogel's quantitative chemical analysis*. Prentice Hall, New Jersey

FG

Probe beam deflection (PBD) — An in-situ electrochemical technique employed to study the mass fluxes

in front of the electrode|electrolyte interface. It is based on measuring the deviation angle (θ) of a probe laser beam that crosses a transparent medium with a non-homogeneous index of refraction [i]. The probe laser beam is aligned parallel to the electrode surface at a given beam–electrode distance (x). Usually, the PBD technique is performed in solutions (e.g., aqueous solutions) where the dependence of the → *refractive index* (n) on thermal gradients is negligible compared to that on concentration gradients ($\delta C/\delta x$) of dissolved species [ii]. Thus, the dependence of θ on the refractive index gradient can be approximated for small deflection angles as: $\theta = (L/n) \sum_j (\partial n/\partial C_j) (\delta C_j/\delta x)$. L is the interaction length between the beam and the zone of perturbed index and $(\partial n/\partial C_j)$ is a constant that depends on the molecular (or ionic) volume and on the electronic structures of each j th solute. In consequence, the PBD technique itself is unspecific since only the sum of all concentration gradients is detected and is necessary to fit the experimental signal with proper mathematical equations for a quantitative analysis of individual fluxes [iii]. The most common probe beam deflection methods are → *chronodeflectometry* and → *cyclic voltadeflectometry*.

There is a convention used to describe the refraction of a probe laser beam that considers the deflection as negative if the beam deviates towards the electrode surface and positive when the opposite deviation occurs. The former corresponds to the generation (or releasing) of soluble species, while the latter is related to the consumption (or inclusion) of reactants during the electrochemical experiment. The deflection signal has the same sign than the refractive index gradient developed from the electrode surface to the solution [iv].

Furthermore, PBD experiments are usually classified as: (a) discontinuous process or (b) continuous process, depending on the electrochemical system that is studied.

- **(a) Discontinuous process** A kind of system in which the amount of species consumed during a potential step is finite (e.g., the ion exchange of a redox oxide or an electroactive polymer, the electrochemical dissolution of a thin layer). Provided that there is a very thin layer of electroactive species, it is possible to assume that the ionic exchange is an instantaneous process [iv].
- **(b) Continuous process** A type of system in which the amount of electroactive species consumed during a potential step can be assumed as infinite [iv].

See also → *mirage effect*.

Refs.: [i] Vieil E, Lopez C (1999) *J Electroanal Chem* 466:218; [ii] Bidoia ED (2005) *Chem Phys Lett* 408:1; [iii] Rudnicki JD, Brisard GM, Gasteiger HA, Russo RE, McLaron FR, Cairns EJ (1993) *J Electroanal Chem* 362:55; [iv] Barbero CA (2005) *Phys Chem Chem Phys* 7:1885

FG

Progressive nucleation → nucleation, subentry → progressive nucleation

Propanol → solvents

Propionitrile → solvents

Propylene carbonate (PC) — Propylene carbonate is a heterocyclic organic, alkyl carbonate solvent, also known as 4-methyl-1,3-dioxolan-2-one; 1,2-propylenecarbonate; 1,2-propanediol cyclic carbonate, and carbonic acid cyclic propylene ester. The commercial method for industrial production of PC is insertion of carbon dioxide into propylene oxide. PC is used generally as a slightly polar, aprotic solvent for nonaqueous electrochemical systems. For instance, it is used as a component in electrolyte solutions for lithium batteries (mostly primary). The → electrochemical window of its solutions may be as wide as 5 V. This depends on the nature or the cation. In tetraalkyl ammonium salt solutions, where there is no electrodes passivation, PC is reduced to $\text{CH}_3\text{CH}=\text{CH}_2$ and $\text{CH}_3\text{-CH}(\text{OCO}_2^-)\text{CH}_2(\text{OCO}_2^-)$ anion at potentials as high as 1 V vs. Li/Li^+ . In the presence of Li ions passivation is developed due to precipitation of $\text{CH}_3\text{CH}(\text{OCO}_2\text{Li})\text{CH}_2(\text{OCO}_2\text{Li})$ and hence the cathodic limit of PC solutions may be ≈ 0 V vs. Li/Li^+ , due to Li deposition processes. → graphite electrodes are usually not passivated in PC/Li^+ salt solutions. The graphite particles exfoliate in PC solutions due to destructive processes related to co-intercalation of PC molecules with the inserted Li^+ ions and gas formation due to decomposition of PC at low potentials. PC is also used as a solvent in agriculture, coloring and textile industry, as an additive in fuel.

Properties: M_W : 102.09 g mol^{-1} , m.p: -50°C , b.p: 200°C , f.p: 132°C , density: 20 g cm^{-3} , dielectric constant: 64.9 (20°C), dipole moment: 4.94 (20°C), solubility of water in PC: 8.3% (25°C), solubility of PC in water: 17.5% (25°C).

Refs.: [i] Tomishige K, Yasuda H, Yoshida Y, Nurunnabi M, Li B, Kunitomori K (2004) *Catal Lett* 95(1–2):45; [ii] Clements JH (2003) *Ind Eng Chem Res* 42:663; [iii] Aurbach D, Gottlieb H (1989) *Electrochim Acta* 34:141; [iv] Aurbach D, Koltypin M, Teller H (2002) *Langmuir* 18:9000;

[v] Aurbach D, Daroux ML, Faguy P, Yeager E (1987) *J Electrochem Soc* 134:1611; [vi] www.chemical-land21.com

DA, LL

Proteins — are macromolecules consisting of peptide-connected α -amino acids, and possessing a complex three-dimensional molecular structure. At the → isoelectric point of a protein, which is basically referred to as a certain pH in solution, the net charge on the molecule is zero (see: → electrophoresis). The electrochemical response of redox-active proteins, e.g., enzymes and co-enzymes, is usually obscured on unmodified metal electrodes. The reason is either the spatial inaccessibility of the redox center in the protein, or an extreme slow kinetics of → electron transfer for other reasons. Great efforts have been made to tailor electrode surfaces as to achieve a reversible or near-reversible response. → Self-assembled monolayers of sulfur-organic compounds on gold, various organic and metal organic mediator molecules, and organic conducting salt electrodes have proven to be beneficial for that purpose.

Refs.: [i] Armstrong FA (2002) *Voltammetry of proteins*. In: Bard AJ, Stratmann M, Wilson GS (eds) *Bioelectrochemistry. Encyclopedia of electrochemistry*, vol. 9. Wiley-VCH, Weinheim, pp 11–30; [ii] Burgess JD, Hawkridge FM (2002) *Direct electrochemistry of proteins and enzymes at electrodes*. In: Brajter A, Chambers JQ (eds) *Electroanalytical methods for biological materials*. Marcel Dekker, New York

MH

Protic solvents → solvents

Protoemeraldine → polyaniline

Proton — The proton is the smallest and lightest positively charged atomic nucleus. Its radius is 10^{-13} cm. The mass of the proton is $m_p \approx 1.67 \times 10^{-24}$ g that is approximately equal to 1836 m_e where m_e is the mass of the → electron. Its energy equivalent is $m_p c^2 = 939.3$ MeV. The charge of the proton is positive and equals the absolute value of the electron charge. The spin of the proton is equal to $1/2$. Protons obey the → Fermi–Dirac statistics. The frequencies of proton valence vibrations in chemical compounds are of the order of 10^{-14} s^{-1} , i.e., the energies of vibrational quanta (spacing of vibrational energy levels) are of the order of tenths of electron volts, which exceeds considerably the thermal energy $k_B T$ (k_B is the → Boltzmann constant, T is the temperature) at room temperature (0.025 eV). Therefore the proton occupies mainly its ground vibrational state. This is a heavy elementary particle, the quantum mechanical properties of which are pronounced at room temperature. They

manifest themselves in a discrete character of vibrational energy spectrum and tunneling. These features are the reasons for the hydrogen isotope effect, i.e., a change of equilibrium or kinetic characteristics when the proton is replaced by its heavier isotopes (deuterium or tritium with the masses $2 m_p$ and $3 m_p$, respectively). Since the vibrational frequency is inversely proportional to the square root of the mass, the increase of the mass results in a decrease of the energies of vibrational quanta. Broadly, tunneling is the penetration of the particle into a classically forbidden region, i.e., in the region where the total energy of the particle is smaller than its potential energy. The probability of tunneling strongly depends on the mass of the particle. Since in all other respects all three isotopes are equivalent, this provides a powerful instrument for the study of intimate mechanisms of kinetic and equilibrium phenomena. Protons play an important role in various equilibrium and kinetic phenomena (acid–base equilibria in solutions, acid–base catalysis, proton conductivity of ice and water, hydrogen evolution at electrodes, proton transport in biological systems, enzyme catalysis, performance of fuel cells, etc.). However, one has to realize that in chemical systems the proton never acts as a “bare” elementary particle, because it is always bound to chemical compounds, neutral (like water molecules H_2O) or charged (like hydroxonium ions H_3O^+). Apart from the formation of strong covalent chemical bonds, the proton is the reason for the formation of hydrogen bonds, i.e., weak bonds between chemical compounds with the proton as bonding agent. This property of protons, in particular, determines to a large extent the structure of liquid water.

See also \rightarrow acid–base theories, \rightarrow Eigen complex, \rightarrow pH, \rightarrow Zundel complex, \rightarrow prototropic charge transport, \rightarrow proton transfer, \rightarrow proton mobility.

Refs.: [i] Bell RP (1973) *The proton in chemistry*. Chapman and Hall, London; [ii] Cohen A, Limbach HH (eds) (2005) *Isotope effects in chemistry and biology*. Marcel Dekker, New York; [iii] Eisenberg D, Kauzmann W (1969) *The structure and properties of water*. Clarendon, Oxford

AMK

Proton conductors \rightarrow solid electrolyte

Proton conducting solid electrolyte \rightarrow solid electrolyte

Proton exchange membrane fuel cell \rightarrow polymer–electrolyte–membrane fuel cell (PEMFC)

Proton hopping \rightarrow proton mobility, see \rightarrow proton transfer

Proton mobility — Proton mobility is a kinetic characteristic of the process of \rightarrow proton transport. A formal

definition of the linear \rightarrow mobility μ is the ratio of the average velocity v of a charged particle moving under an electric field E to the absolute value of this field, i.e., $\mu = v/E$. The total mobility of the particle in general is provided by various microscopic mechanisms and represents an average quantity. According to the Debye–Einstein (\rightarrow Nernst–Einstein equation) relationship it is related to the diffusion coefficient D by $\mu = eD/k_B T$. The mobility of protons in water is approximately five times higher than the mobility of an alkali metal cation of a similar size as the hydronium ion H_3O^+ . It is related to the structure of water and aqueous solutions.

Two main classes of proton mobility (diffusion) mechanisms are distinguished in liquid water: (a) classical (hydrodynamic) diffusion (migration) of H_3O^+ ion, and (b) structural diffusion. The diffusion of bare or hydrated hydronium ions is involved in the first class. Structural diffusion implies a shift of structural units as a result of rearrangement of the protons without a considerable shift of water molecules themselves. It is this mechanism which distinguishes proton mobility from the mobility of other ions and contributes to the so-called excess proton mobility μ_{excess} . This mechanism is also called \rightarrow prototropic charge transport, proton exchange, or the \rightarrow Grotthuss mechanism [iv]. The latter is due to proton hopping to various discrete distances a_k within different structural units

$$\mu_{\text{excess}} = \frac{e}{k_B T} \sum_k P_k W_k a_k^2$$

where W_k is the probability (per unit time) of the hop to the distance a_k by a certain mechanism k , and P_k is a fraction of this mechanism in the whole process ($\sum_k P_k = 1$).

Structural diffusion is provided by various complexes: bare hydronium ion, \rightarrow Eigen complexes, and \rightarrow Zundel complexes. Structural diffusion of bare hydronium ion and Eigen complexes occurs by proton hops between two water molecules. Two or more protons and several water molecules are involved in the structural diffusion of Zundel complexes. The contribution of mechanisms to the overall mobility depends on the temperature. Eigen and Zundel complexes prevail at room temperature, whereas bare hydronium ions dominate at high temperatures. Excess proton mobility of water has Arrhenius-like (\rightarrow Arrhenius equation) temperature dependence with the \rightarrow activation energy about 0.11 eV.

Refs.: [i] Agmon N (1995) *Chem Phys Lett* 244:456; [ii] Marx D, Tuckerman ME, Hutter J, Parrinello M (1999) *Nature* 397:601; [iii] Kornyshev AA, Kuznetsov AM, Spohr E, Ulstrup J (2003) *J Phys Chem B* 107:3351;

[iv] Erdey-Grúz T (1974) *Transport phenomena in aqueous solutions*. A Hilger, London, pp 253–393

AMK

Proton pump (physiology) → ion transport through membranes and ion channels

Proton transfer → proton transfer is a translocation of the protons in condensed media and molecular systems by means of any microscopic mechanism of proton transfer. The latter may involve (1) vehicle motion of the hydrogen ion, (2) proton hopping between two molecular species, (3) a shift of the proton within a molecular structure. The motion of the hydrogen ion is a diffusion process. Two other mechanisms represent elementary reaction steps involving breaking and formation of chemical bonds and may be characterized by the reaction rate constant

$$k = \delta V (\omega/2\pi) \kappa \exp(-F_a/k_B T)$$

where δV is the reaction volume, ω is the effective frequency of classical nuclear modes ($\hbar\omega < k_B T$), F_a is the activation free energy, and κ the transmission coefficient.

They are largely determined by the reorganization of the molecular structure and surrounding medium. Mechanism (2) implies a weak interaction between the proton donor and acceptor sites. The proton transition occurs when the discrete proton vibrational energy levels match. This is achieved due to (mainly classical) change of molecular and medium configuration that determines the activation free energy of the process. The proton transition at this configuration may have over-barrier or sub-barrier (tunnel) character depending on the shape of the double-well potential profile along the proton coordinate. The probability of this transition determines the transmission coefficient. When the potential barrier along the proton coordinate is lower than the position of the ground vibrational proton level, the transition is over-barrier and the process as a whole is adiabatic with $\kappa = 1$. In the case of high and narrow potential barriers the proton tunnels mainly between the ground vibrational levels and the process as a whole (in spite of the proton tunneling) may be either totally adiabatic ($\kappa = 1$) or ‘partially adiabatic’ ($\kappa < 1$), depending on the probability of the proton transition. The notion partially adiabatic means that the electrons adiabatically follow the motion of nuclei but the proton does not follow adiabatically the motion of classical subsystems. The adiabatic and partially adiabatic mechanisms involving

proton tunneling are characterized by a large hydrogen isotope effect. Mechanism (3) operates in hydrogen-bonded proton donor–acceptor complexes with short and strong hydrogen bonds. The potential profile along the proton coordinate has in this case a single-well shape with the minimum of the potential well shifted towards the proton donor or proton acceptor depending on the configuration of the molecular environment. The mechanism of the transition closely resembles an S_N2 -mechanism of substitution reactions and involves the breaking and formation of hydrogen bonds of the reaction complex with surrounding molecules. A fluctuation of the molecular environment results then in a shift of the minimum of the proton potential well to an intermediate position between the donor and acceptor with subsequent relaxation of both to a final equilibrium configuration. The process is totally adiabatic and no tunneling or excitation of proton vibrations takes place in this case. The system moves on the lower adiabatic free energy surface along the molecular environment coordinates, and the activation free energy is influenced by the difference of the proton zero-point vibration energies at the transition configuration and in the initial state. The hydrogen isotope effect is small.

Refs.: [i] Kuznetsov AM (1995) *Charge transfer in physics, chemistry and biology*. Gordon & Breach, Reading; [ii] Cohen A, Limbach HH (eds) (2005) *Isotope effects in chemistry and biology*. Marcel Dekker, New York; [iii] Kuznetsov AM, Ulstrup J (2004) *Russ J Electrochemistry* 40:1161, 1172

AMK

Prototropic charge transport — The limiting values of the equivalent → conductivity of ions is about 30–80 cm²Ω⁻¹ at 25 °C in aqueous solutions, except that of hydrogen and hydroxide ions which have much higher conductivities ($\lambda_{H^+}^0 = 350$ cm²Ω⁻¹, $\lambda_{OH^-}^0 = 199$ cm²Ω⁻¹) [i–iii]. For the explanation of these, anomalously high conductivities several theories have been developed. The most accepted one is based on a proton exchange (prototropic) mechanism involving the transfer of protons from water molecules or hydroxonium (hydronium ion, oxonium ion, hydrated proton, H₃O⁺) ion to neighboring water molecules or ions, respectively, i.e., practically a transfer of bonds connected with changes of the position of the proton between neighboring water molecules. This process can be described schematically as shown in the figure on the following page.

This mechanism of prototropic conduction is similar to that proposed by → Grotthuss for the electrolytic conduction, and therefore is sometimes also

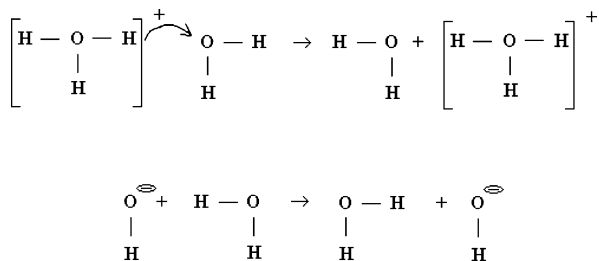

Prototropic charge transport — Figure

called → *Grotthuss mechanism*. (Grotthuss assumed that water molecules are polarized; the hydrogen fragments will have a positive, while the oxygen fragments a negative charge when water is **electrolyzed**. When one positively charged hydrogen is removed at the → *pole*, the next one jumps into its place [iv].) The protonic jump between ions and water molecules occurs continuously, however, the electric field makes these processes ordered so that they contribute to the → *charge transport*.

If the hydroxonium ions migrated only hydrodynamically $\lambda^{\circ} \sim 85 \text{ cm}^2 \Omega^{-1}$ would be expected, which value can easily be derived by using the → *Stokes law* and the known values of the → *self-diffusion* coefficient of water, the radius of the ion and the → *viscosity*. (See also → *proton*, → *Eigen complexes*, → *Zundel complexes*, → *charge transfer*, → *Dahms–Ruff theory*.)

Refs.: [i] Erdey-Grúz T (1974) *Transport phenomena in aqueous solutions*, Adam Hilger, London, p 278; [ii] Bernal JD, Fowler RH (1933) *J Chem Phys* 1:515; [iii] Bockris JO'M, Reddy AKN (1998) *Modern electrochemistry: ionics*, vol. 1, Plenum Press, New York; [iv] Grotthuss Th (1805) *Abhandlungen über Elektrizität und Licht*, Ostwalds Klassiker (1906) Bd.152, Engelmann, Leipzig

Prussian blue — iron(III) hexacyanoferrate(II) is the archetype of sparingly soluble mixed valence polymeric metal hexacyanometalates with the formula $\text{Me}^{(i)}\{\text{Me}^{(N)}[\text{Me}^{(C)}(\text{CN})_6]\}$ with (i), (N), and (C) indicating the position in the crystal lattice, where (i) means interstitial sites, (N) means metal coordinated to the nitrogen of the cyanides, and (C) means metal ions coordinated to the carbon of the cyanides. It is one of the oldest synthetically produced coordination compounds and was widely used as pigment in paints because of the intensive blue color. The compound has been studied extensively by electrochemical and other methods. The importance of Prussian blue in electrochemistry is related to the fact that it has two redox-active metal centers and that it has an open structure that allows small cations to

enter the solid crystals and to diffuse inside the material. It shows reversible → *insertion electrochemistry*, → *electrochromism*, and it possesses electrocatalytic activities (→ *electrocatalysis*).

Refs.: [i] Ludi A (1988) *Chem unserer Zeit* 22:123; [ii] Sharpe AG (1976) *The chemistry of cyano complexes of the transition metals*. Academic Press, London; [iii] (1932) *Gmelins Handbuch der Anorganischen Chemie*, 59B[Fe]. Verlag Chemie, Berlin; [iv] Scholz F, Kahlert H (2006) *Electrochemistry of polycyanometalates*. In: Bard AJ, Stratmann M, Scholz F Pickett CJ (eds) *Inorganic chemistry. Encyclopedia of electrochemistry*, vol. 7b. Wiley-VCH, Weinheim, pp 701–721

HK

Pseudoreference electrode → *reference electrodes*, and → *quasireference electrode*

Pseudocapacitance — Pseudocapacitance C_x [F m^{-2}] is a differential → *capacitance* characterizing an → *electrode* charging/discharging process in which an oxidized or reduced electroodic film is formed or destroyed, $C_x = (\partial Q/\partial E)$, where Q is the → *charge* [C cm^{-2}] and E is the → *potential* [V]. The name pseudocapacitance reflects the leaky nature of a capacitor formed by this charging/discharging process and emphasizes the fact that there are no physical charges present in the electroodic film resembling an ideal plate capacitor. Originally, pseudocapacitance was defined for → *chemisorption* processes, but further extensions of the pseudocapacitance concept have been proposed for multilayer films, thick redox and → *conductive polymer* films, as well as the electroodic films in → *batteries* (where the charge capacity is a form of pseudocapacitance).

At the monolayer level, chemisorption processes related to pseudocapacitance can proceed with either a full charge transfer (e.g., $\text{Cl}_{(\text{aq})}^- + \text{Ag}_{(s)} - e^- \rightleftharpoons \text{AgCl}_{(\text{ads})}$) or a partial charge transfer (e.g., adsorption of organic molecules or → *underpotential deposition* of metals). These processes can be reversible, kinetically controlled (slow → *charge transfer* or slow → *adsorption*) or → *mass transport* controlled. In a particular case, when both the reactant and product of a redox process are adsorbed on the electrode surface, the pseudocapacitance of such a surface film can be charged without desorption of electroactive components of the film (although an ingress/egress of counter ions from the solution must still take place), for instance, oxidation of multivalent metal oxide films or conducting polymer films. A diagnostic criterion for a reversible surface-bound redox couple is a cyclic voltammetry characteristic with equal anodic and cathodic peak potentials ($E_{p,a} = E_{p,c}$).

GI

Pseudocapacitance C_x acts as a capacitance of the chemisorption film (forming a pseudocapacitor) and is coupled to the \rightarrow double-layer capacitance C_{dl} . In many electroanalytical techniques, both capacitors can be charged (discharged) either galvanostatically or by variation of the electrode potential and thus can be measured (and separated) by monitoring the charging (discharging) current, e.g., in \rightarrow cyclic voltammetry, \rightarrow chronocoulometry, \rightarrow electrochemical impedance spectroscopy. In the latter technique, in an equivalent electric circuit designed to simulate frequency dependence of the electrode|solution interface at which a chemisorption process is encountered, the pseudocapacitance C_x appears in series with charge transfer resistance R_{ct} [Ω m²] and in parallel to the double-layer capacitance C_{dl} [F m⁻²]. The leakage of a pseudocapacitor is represented by a resistance R_x parallel to C_x . The measured values of pseudocapacitance may be very large, e.g. $C_x > 1000 \mu\text{F cm}^{-2}$. Hence, $C_x \gg C_{dl}$, since $C_{dl} \approx 20 \mu\text{F cm}^{-2}$ for a typical metal in solution. Theoretical values of C_x can be evaluated using electrochemical adsorption isotherms such as \rightarrow Frumkin, \rightarrow Langmuir, or Flory-Huggins isotherms. For instance, for a chemisorption of metal adatoms using electrochemical Frumkin adsorption isotherm, we have:

$$\frac{\theta}{1-\theta} = c_j \exp \left\{ -\frac{nF(E - E_c^{\ominus'})}{RT} \right\} \exp \{-g\theta\} \quad (1)$$

where θ is the surface coverage by adsorbate, c_j its dimensionless concentration in solution (relative to the standard state), n the number of electrons transferred, E the equilibrium potential [V], $E_c^{\ominus'}$ formal potential [V], g the lateral interaction coefficient ($g > 0$ for repulsions and $-4 < g < 0$ for attractions), F is the \rightarrow Faraday constant, R is the \rightarrow gas constant, and T the absolute temperature [K]. By differentiating the above equation with respect to E , one can obtain an expression for pseudocapacitance as follows:

$$C_x = \frac{nFQ_{\text{mono}}}{RT} \frac{\theta(1-\theta)}{[1 + g\theta(1-\theta)]} \quad (2)$$

where Q_{mono} is the monolayer charge [Ccm⁻²]. Pseudocapacitance currents $j = \nu C_x(E)$ in [A], where ν is the potential scan rate [V s⁻¹], can be recorded using linear potential scan voltammetry for single adsorbates and coadsorption systems, under reversible and irreversible conditions. For a simple reversible chemisorption process with no lateral interactions ($g = 0$), the ex-

pression for pseudocapacitance peak current density in cyclic voltammetry is given by:

$$j_p = \frac{n^2 F^2}{4RT} \nu \Gamma_a \quad (3)$$

where Γ_a [mol cm⁻²] is the surface excess of electroactive species. For a monolayer coverage, $\Gamma_a = \Gamma_{\text{mono}} = Q_{\text{mono}}/(nF)$ and $j_p = 9.3894 \times 10^5 n^2 \nu \Gamma_{\text{mono}} = 9.7314 n \nu Q_{\text{mono}}$ (at room temperature). Thus, for a typical one-electron chemisorption process on a Pt(111) surface with $Q_{\text{mono}} = 245 \mu\text{C cm}^{-2}$ (corresponding to $\Gamma_{\text{mono}} = 2.54 \text{ nmol cm}^{-2}$), $n = 1$, and $\nu = 0.1 \text{ V s}^{-1}$, the pseudocapacitance peak current density would be $j_p = 238 \mu\text{A cm}^{-2}$ and $C_{x,p} = 2380 \mu\text{F cm}^{-2}$. The effects of chemisorption and film formation have been well characterized for the \rightarrow dropping mercury electrode and recently extended to single crystal metal and \rightarrow semiconductor electrodes. For thicker reversible films, the pseudocapacitance peak current can often be estimated by replacing the surface excess Γ_a in Eq. (3) with an areal density of electroactive species C_s [mol cm⁻²] or electroactive material loading m_s [mol cm⁻²].

Refs.: [i] Damaskin BB, Petrii OA, Batrakov VV (1971) *Adsorption of organic compounds on electrodes*. Plenum, New York; [ii] Hapel T (1984) *J Electroanal Chem* 175:15; [iii] Sluyters-Rehbach M (1994) *Pure Appl Chem* 66:1831; [iv] Retter U, Lohse H (2002) *Electrochemical impedance spectroscopy*. In: Scholz F (ed) *Electroanalytical methods*. Springer, Berlin, pp 149–166

MHep

Pseudocapacitor \rightarrow supercapacitor

Pseudopolarogram — In \rightarrow anodic stripping voltammetry of \rightarrow amalgam-forming metal ions, the plot of stripping peak currents versus the accumulation potentials is called pseudopolarogram. It resembles a DC \rightarrow polarogram, with a \rightarrow limiting current which is linearly proportional to the bulk concentration of metal ions. On a thin mercury film-covered \rightarrow rotating disk electrode, the \rightarrow half-wave potential of the pseudopolarogram is given by the following equation:

$$E_{1/2} = E^{\ominus} + \frac{RT}{nF} \ln \frac{1.594L\delta}{Dt_{\text{acc}}}$$

where E^{\ominus} is the standard potential, n is the number of electrons, L is the mercury film thickness, δ is the diffusion layer thickness, D is the diffusion coefficient, t_{acc} is the accumulation time, and F , R , and T have their usual

meanings. The pseudopolarograms are used for the determination of \rightarrow *deposition potentials* in anodic stripping voltammetry and for the speciation of metal ions (see \rightarrow *pseudopolarography*).

Ref.: [i] Lovrić M (1998) *Electroanalysis* 10:1022

MLo

Pseudopolarography — It is an electrochemical method for the speciation measurements of trace metals in natural waters. Pseudopolarography is based on repetitive \rightarrow *anodic stripping voltammetric* experiments with varying potentials of accumulation. A plot of stripping peak currents versus the \rightarrow *deposition potential* is a curve that resembles the DC \rightarrow *polarogram* (see the Figure). It is called the \rightarrow *pseudopolarogram*. It reflects both the thermodynamic and the kinetic properties of metal ions as well as the geometric and hydrodynamic characteristics of the \rightarrow *working electrode*. As in DC polarography, the \rightarrow *limiting current* of the pseudopolarogram is a linear function of the metal ion concentration, while its \rightarrow *half-wave potential* is independent of the concentration. In the case of \rightarrow *reversible*, labile \rightarrow *complex* formation in the solution, the half-wave potential of the pseudopolarogram of the metal ion which forms the complexes is shifted towards lower potentials in the same way as in DC polarography [i]. So, the \rightarrow *stability constants* of complexes can be calculated from pseudopolarographic data using the methods developed for DC polarography [ii].

Refs.: [i] Branica M, Novak DM, Bubić S (1977) *Croat Chem Acta* 49:539;

[ii] Branica G, Lovrić M (1997) *Electrochim Acta* 42:1247

MLo

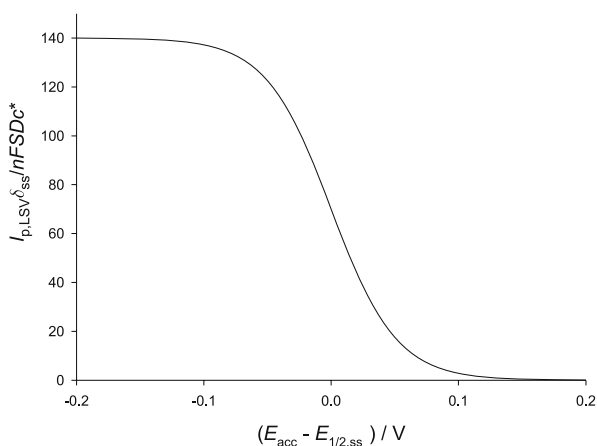

Pseudopolarography — Figure. Theoretical pseudopolarogram

Pulse polarography \rightarrow *polarography*, and \rightarrow *pulse voltammetry*

Pulse voltammetry — A technique in which a sequence of potential pulses is superimposed to a linear or staircase voltage ramp. The current is usually measured at the end of the pulses to depress the \rightarrow *capacitive (charging) current*. Depending on the way the pulses are applied and the current is sampled we talk about \rightarrow *normal pulse voltammetry*, \rightarrow *reverse pulse voltammetry* and \rightarrow *differential pulse voltammetry*. Several other, less popular pulse techniques are offered in commercial voltammetric instrumentation. Some people consider \rightarrow *square-wave voltammetry* as a pulse technique.

Ref.: [i] Stojek Z (2002) *Pulse voltammetry*. In: Scholz F (ed) *Electroanalytical methods*. Springer, Berlin

ZS

Pulvermacher's chain — This was a \rightarrow *battery* consisting of copper and zinc wires wound around pencil-like wooden sticks, and the sticks connected in a chain-like manner. The wooden sticks were soaked with dilute acetic acid, so that the chain produced electricity also when removed from an electrolyte bath. The chain was used in galvanic therapy.

See also \rightarrow *Daniell cell*, \rightarrow *zinc*, \rightarrow *Zn²⁺/Zn electrodes*, \rightarrow *Zn²⁺/Zn(Hg) electrodes*, \rightarrow *zinc-air batteries (cell)*, and \rightarrow *Leclanché cell*.

Ref.: [i] Hauck WP (1883) *Die Galvanischen Batterien, Accumulatoren und Thermosäulen*, 2nd edn. Hartleben's Verlag, Wien

FS

Pyrochlores — comprise a large group of compounds isostructural to the $(Ca,Na)_2Nb_2O_6(OH,F)$ pyrochlore mineral, and their derivatives. The general formula is $A_2B_2O_6O'$, where the A sites can be occupied by mono-, di-, and trivalent cations (for example: Na^+ , Ca^{2+} , La^{3+}), the oxidation state of B-site cations varies usually from 4+ to 6+ (for example: Ti^{4+} , Zr^{4+} , Nb^{5+} , Mo^{6+}), and the oxygen sites may be partly substituted with other anions, such as OH^- and F^- . The A:B cation ratio is not absolutely rigid; furthermore, the pyrochlore structure may tolerate formation of cation and anion \rightarrow *vacancies*, various \rightarrow *doping*, and antistructural (antisite) disorders of the cations (see also \rightarrow *defects in solids*). The pyrochlore crystal lattice is often considered as a cation-ordered defective derivative of the CaF_2 -type fluorite structure [i, ii], characteristic of many oxygen ion conductors such as \rightarrow *cerium dioxide* and δ -phase of \rightarrow *bismuth oxide*. Pyrochlore materials find numerous applications for electroceramics, actinide

host matrices in nuclear wastes, catalysts, fluorescence centers, etc. The potential electrochemical applications are related to a significant oxygen → *ion conductivity* of → *solid electrolytes* based on rare-earth titanates and zirconates, to → *cation* conductivity of the pyrochlores containing alkaline metal ions in the A sublattice, and to mixed ionic–electronic conductivity of transition metal-containing pyrochlores [ii, iii]. At the same time, formation of pyrochlore phases at the interface between electrode and electrolyte of → *solid oxide fuel*

cells (SOFC) with → *stabilized zirconia* electrolytes has a strong deteriorating effect on the SOFC performance.

See also: → *conducting solids*, → *doping*.

Refs.: [i] Minervini L, Grimes RW, Sickafus KE (2000) *J Am Ceram Soc* 83:1873; [ii] van Dijk MP, de Vries KJ, Burggraaf AJ (1983) *Solid State Ionics* 9/10:913; [iii] Kramer SA, Tuller HL (1995) *Solid State Ionics* 82:15

VK

Pyrolytic graphite electrode → *graphite electrode*

Q

QCM → quartz crystal microbalance

QCN → quartz crystal nanobalance

Quadratic mean → root mean square

Quantitation limit → limit of quantitation

Quartz crystal microbalance — The quartz crystal microbalance (QCM) or nanobalance (QCN) is a thickness-shear-mode acoustic wave mass-sensitive detector based on the effect of an attached foreign mass on the resonant frequency of an oscillating quartz crystal. The QCM responds to any interfacial mass change. The response of a QCM is also extremely sensitive to the mass (density) and viscoelastic changes at the solid-solution interface [i–vi].

It is a piezoelectric (→ *piezoelectricity*) sensing device that consist of an oscillator circuit and a crystal which is incorporated into the feedback loop of the circuit. The crystal is the frequency-determining element, as its quality factor is very high.

The piezoelectric crystals are patterned with two excitation electrodes (electronic surface films) on their opposite sides. Due to the converse piezoelectricity phenomenon, when → *alternating voltage* is applied to the attached electrodes mechanical oscillations occur within the crystal lattice. These oscillations are stable only at the natural resonant frequency of the crystal.

The crystal cut determines the mode of oscillations. Shear vibrations are generated if one large crystal face moves parallel with respect to the underlying planes as in QCMs with AT-cut α -quartz crystals. This crystal wafer is prepared by cutting the quartz at approximately 35.17° from its Z-axis. A typical crystal plate is a cylindrical disk of a diameter 10 mm and thickness about 0.7 to 0.1 mm for resonant operation in the 2 to 15 MHz frequency range. This type of crystals shows weak dependence of the resonant frequency on the temperature and stress for room temperature operation.

The fundamental resonant frequency (f_o) shifts when a thin film is deposited on the surface of the quartz crystal. Under the assumption that the density and the shear modulus of the film are the same as those of quartz and that the film is uniform (constant density and thickness) and covering the acoustically active area of the whole

crystal, the **Sauerbrey equation** [iv] describes the relationship between the resonant frequency shift (Δf) and the added mass (ΔM):

$$\Delta f = f_c - f_o = -\frac{2f_o^2 \Delta M}{A(\rho_q \mu_q)^{1/2}} = -C_f \Delta m, \quad (1)$$

where f_c is the resonant frequency of the composite oscillator formed from the crystal and the film at the surface, A is the acoustically active surface area, $\rho_q = 2.648 \text{ g cm}^{-3}$ and $\mu_q = 2.947 \times 10^{10} \text{ N m}^{-2}$ are the density and the shear modulus of quartz, respectively, Δm the change of the surface mass density, and C_f is the integral mass sensitivity.

Since

$$f_o = \frac{v_q}{2L_q}, \quad (2)$$

where $v_q = \left(\frac{\mu_q}{\rho_q}\right)^{1/2}$ is the wave speed for quartz ($v_q = 3336 \text{ m s}^{-1}$) and L_q is the thickness of the quartz, in this case the only difference between the film-coated and uncoated quartz is the added thickness (ΔL_f). The film should not be too thick, the mass loading should be lower than 2% of the mass of the quartz plate, i.e., typically lower than $20 \mu\text{g cm}^{-2}$. There may be non-mass-related frequency changes due to stress (e.g., caused by an improper mounting) and temperature effects [i, iii].

The values of the integral mass sensitivity for the most frequently used $f_o = 5 \text{ MHz}$ and 10 MHz crystals are $C_f = 5.66 \times 10^7$ and $2.264 \times 10^8 \text{ Hz cm}^2 \text{ g}^{-1}$, respectively. It follows that by using a crystal with $A = 0.3 \text{ cm}^2$ surface area 1 Hz change – which can be measured easily and accurately – corresponds to 6 ng and 1.4 ng, respectively. The uniform distribution of the mass over the active area of the quartz plate is of importance since the differential mass sensitivity (c_f) varies across this area. For typically used round-shape crystals [i, vii]:

$$C_f = 2\pi \int_0^r c_f(r) r dr. \quad (3)$$

The resonant frequency also depends on the density and the viscosity of the contacting media. The frequency shift for measurement in air vs. vacuum is smaller than 10 Hz. However, the frequency shift from air to water or aqueous solution, for a 10 MHz crystal is about 4–12 kHz. The magnitude of this shift can be calculated by using the following relationship:

$$\Delta f = -f_o^{3/2} \left(\frac{\rho_L \eta_L}{\pi \rho_q \mu_q} \right)^{1/2} \quad (4)$$

where ρ_L and η_L are the density and viscosity of the liquid contacting one side of the crystal.

The additional surface mass change can be measured and calculated by using the Sauerbrey equation even in the case when the crystal is in contact with a liquid. It makes the in-situ detection of the surface mass changes possible in the course of electrochemical experiments by using an \rightarrow *electrochemical quartz crystal microbalance (EQCM)*. A lack of conformance with the Sauerbrey equation may be traced back to high-mass loading, surface roughness, surface stress, interfacial slippage, nonuniform mass distribution, and viscoelastic effects. In the latter case the film does not behave as a rigid layer, i.e., the deformation is not purely elastic. It happens when the film is thick and its morphology changes due to, e.g., its swelling.

The frequency can be measured by the help of a frequency counter with an accuracy of 0.1 Hz and sampling time 0.1–1 s.

Q

Refs.: [i] Lu C, Czanderna AW (eds) (1984) *Applications of piezoelectric quartz crystal microbalances*. Elsevier, New York; [ii] Buttry DA (1991) *Applications of the quartz crystal microbalance to electrochemistry*. In: Bard AJ (ed) *Electroanalytical chemistry*, vol. 17. Marcel Dekker, New York, pp 1–85; [iii] Buck RP, Lindner E, Kutner W, Inzelt G (2004) *Pure Appl Chem* 76:1139; [iv] Sauerbrey G (1959) *Z Phys* 155:206; [v] Buttry DA, Ward MD (1992) *Chem Rev* 92:1355; [vi] O'Sullivan CK, Guilbault (1999) *Biosens Bioelectron* 14:663; [vii] Bácskai J, Láng G, Inzelt G (1991) *J Electroanal Chem* 319:55

Quasielastic light scattering (QELS) — from thermally excited \rightarrow *capillary waves* provides a useful insight into dynamics of liquid surfaces [i] and \rightarrow *interfaces* [ii]. Essentially, this approach allows investigating the dispersion relationship, which relates the complex angular frequency $\omega = \omega_0 + i\Delta\omega$ ($i = \sqrt{-1}$) of the capillary wave to the capillary wavelength Λ (wavenumber $k = 2\pi/\Lambda$) [iii]. Experimentally, the correlation function $G(t)$ (t is time) [iv] or the power spectrum of the scattered light can be measured by using the optical heterodyne technique for a selected wavenumber k [i]. The power spectrum is approximately lorentzian in form, and is characterized by a peak frequency $f_0 = \omega_0/2\pi$ and a linewidth $\Delta f = \Delta\omega/2\pi$ [iii]. To a first approximation, the peak frequency f_0 of the capillary wave on a water–organic solvent interface can be described by the Lamb's equation [v],

$$f_0 = \frac{1}{2\pi} \left(\frac{\gamma k^3}{\rho^w + \rho^o} \right)^{1/2},$$

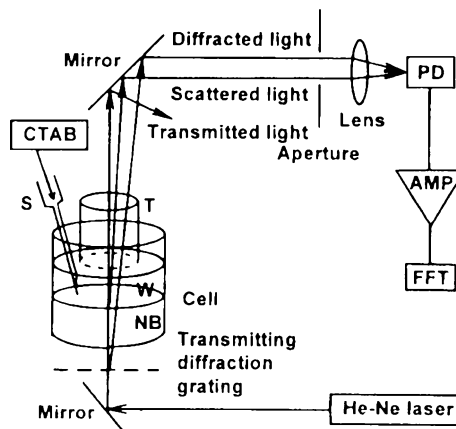

Quasielastic light scattering (QELS) — Figure. Scheme of the experimental set up for QELS measurements: w – aqueous solution, NB – organic solvent solution, S – microsyringe, T – glass tube, PD – photodiode, AMP – pre-amplifier, FFT analyzer. Reprinted with permission from [vi]. © 1997 American Chemical Society

where γ is the \rightarrow *surface tension*, ρ^w and ρ^o are the densities of the aqueous (w) and the organic solvent (o) phase, respectively. The linewidth Δf reflects the damping of the capillary waves due to the bulk viscosities of the two phases [iii]. Application of the QELS method has been extended to study of dynamics of nonpolarizable [vi] and ideally polarizable [vii] ITIES (\rightarrow *interface of two immiscible electrolyte solutions*). Following the simplified description of the method [vi], the incident beam normal to the interface is quasielastically scattered by the thermally excited capillary wave with a Doppler shift at an angle determined by the ratio of the wavenumbers of the incident beam and the capillary wave (Figure). The scattered beam is optically mixed with the incident beam at the selected angle by means of a transmission diffraction grating, which yields an optical beat detected at the same frequency as the Doppler shift (capillary wave frequency).

GI

Refs.: [i] Hard S, Hamnerius Y, Nilsson O (1976) *J Appl Phys* 47:2433; [ii] Löfgren H, Neuman RD, Scriven LE, Davis HT (1984) *J Colloid Interface Sci* 98:175; [iii] Laudon R (1984) *Ripples on liquid interfaces*. In: Agranovich VM, Laudon R (eds) *Surface excitations*. North Holland, Amsterdam, pp 591–638; [iv] Byrne D, Earnshaw JC (1977) *J Phys D Appl Phys* 10:L207; [v] Lamb H (1945) *Hydrodynamics*. Dover, New York, p 348; [vi] Zhang Z, Tsuyumoto I, Takahashi S, Kitamori T, Sawada T (1997) *J Phys Chem A* 101:4163; [vii] Samec Z, Trojáněk A, Krtil (2005) *Faraday Discuss* 129:301

ZSam

Quasi-Fermi level — The quasi-Fermi level is a hypothetical energy level introduced by W. Shockley to de-

scribe the behavior of charge carriers under nonequilibrium conditions in \rightarrow *semiconductors*. It correctly predicts the concentration of charge carriers, electrons in the \rightarrow *conduction band*, or holes in the \rightarrow *valence band*, if these are assumed to be in thermal equilibrium at the lattice temperature and if the quasi-Fermi level is used in the Fermi–Dirac distribution function (\rightarrow *Fermi–Dirac statistics*) in substitution to the \rightarrow *Fermi level*. In the case of nonequilibrium conditions, no single Fermi-level exists and the quasi-Fermi levels for \rightarrow *electrons* and \rightarrow *holes* serve the purpose for which the Fermi level alone was adequate at thermal equilibrium. The quasi-Fermi levels essentially are \rightarrow *electrochemical potentials* for electrons and holes, in a different terminology, because it is widespread practice, in semiconductor physics, to refer to the chemical potential of a semiconductor as the Fermi level.

Refs.: [i] Shockley W (1950) *Electrons and holes in semiconductors*. Van Nostrand, New York; [ii] Blakemore JS (1987) *Semiconductor statistics*. Dover, New York; [iii] Rhoderick EH (1978) *Metal-semiconductor contacts*. Clarendon Press, Oxford; [iv] Ashcroft W, Mermin ND (1976) *Solid state physics*. Saunders College, Philadelphia; [v] Seeger K (1991) *Semiconductor physics – an introduction*. Springer, Berlin

IH

Quasireference electrode (QRE) — (\rightarrow *reference electrode*, pseudoreference electrode). An electrode that maintains a given, but generally not well-defined, potential during the course of a series of electrochemical experiments. It has the advantage of not contaminating the test solution by solvent or ions that a conventional reference electrode might contain and transfer. Thus in studies in aprotic solvents, like acetonitrile, a silver wire can behave as a QRE. It must be calibrated with respect to a true reference electrode or reference redox couple that is added at the end of the experiments to obtain meaningful potential values.

Refs.: [i] Bard AJ, Faulkner LR (2001) *Electrochemical methods*, 2nd edn. Wiley, New York, p 53; [ii] Ghilane J, Hapiot P, Bard AJ (2006) *Anal Chem* 78:6868

AJB

Quasireversibility \rightarrow *reversibility*

Quasireversible maximum — is a feature of the square-wave voltammetric response (see \rightarrow *square-wave voltammetry*) of a kinetically controlled \rightarrow *electrode reaction* in which at least one component of the \rightarrow *redox couple* is immobilized on the \rightarrow *electrode surface* [i] and kinetically controlled electrode reaction occurring in a restricted diffusion space [ii] (see \rightarrow *thin-film electrode* and

\rightarrow *thin-layer*). The quasireversible maximum is manifested as a parabola-like dependence of the ratio $\frac{\Delta I_p}{\sqrt{f}}$ (or $\frac{\Delta I_p}{f}$) versus f , where ΔI_p is the \rightarrow *peak current* of the net SW peak and f is the frequency of the square-wave potential modulation (see \rightarrow *square-wave voltammetry*). The maximum of the parabolic curve is positioned within the quasireversible kinetic region of the electrode reaction. The quasireversible maximum arises as a consequence of the current sampling procedure used in \rightarrow *square-wave voltammetry* and chronoamperometric characteristics (see \rightarrow *chronoamperometry*) of the surface-confined electrode reactions, or reactions confined within a thin film. Under conditions of the quasireversible maximum the rate of the electrode reaction is synchronized with the frequency of the square-wave potential modulation. Hence, the position of the maximum is dictated by the \rightarrow *standard rate constant* of the electrode reaction. The position of the quasireversible maximum can be theoretically predicted on the basis of numerical simulations of the electrode reaction. The standard rate constant of the electrode reaction can be readily estimated by comparing the position of the theoretically predicted and experimentally measured quasireversible maximum. Although primarily typical for square-wave voltammetry, the quasireversible maximum can be also observed with other pulse-nature voltammetric techniques (see \rightarrow *pulse voltammetry*).

Refs.: [i] Lovrić M (2002) *Square-wave voltammetry*. In: Scholz F (ed) *Electroanalytical methods. Guide to experiments and applications*. Springer, Berlin, p III; [ii] Mirčeski V (2004) *J Phys Chem B* 108:13719; [iii] Mirčeski V, Komorsky-Lovrić Š, Lovrić M (2007) *Square-wave voltammetry*. In: Scholz F (ed) *Monographs in Electrochemistry*. Springer, Berlin

VM

Quincke, Georg Hermann



(Reproduced from [i])

(Nov. 19, 1834, Frankfurt an der Oder, Germany – Jan. 13, 1924, Heidelberg, Germany) German physicist who

studied in Berlin, Königsberg, and Heidelberg. In 1865 he became Professor in Berlin, in 1872 in Würzburg, and in 1875 in Heidelberg [i]. Q. contributed to the fields of acoustics, optics, electricity, and magnetic susceptibility measurement. In relation to electrochemistry he is remembered for his studies of \rightarrow *electrokinetic effects*, particularly \rightarrow *Quincke rotation* [ii–vii].

Refs.: [i] König W (1924) *Naturwissenschaften* 12:621; [ii] Quincke G (1859) *Pogg Ann Phys* 107:1; [iii] Quincke G (1860) *Pogg Ann Phys* 110:38; [iv] Quincke G (1861) *Pogg Ann Phys* 113:513; [v] Quincke G (1869) *Pogg Ann Phys* 137:402; [vi] Quincke G (1871) *Pogg Ann Phys* 144:1; [vii] Quincke G (1871) *Pogg Ann Phys* 144:161

FS

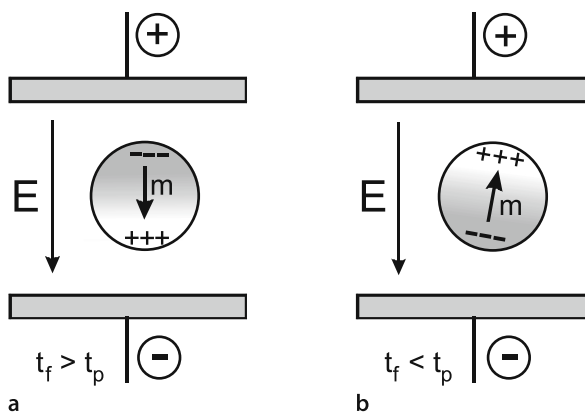

Quincke rotation — Figure

Refs.: [i] Quincke G (1896) *Ann Phys Chem* 59:417; [ii] Melcher JR (1974) *IEEE Trans Educ E-17:100*; [iii] Jones TB (1984) *IEEE Trans Ind Appl IA-20:845*; [iv] Turcu I (1987) *J Phys Math Gen* 20:3301; [v] Lamaire E, Lobry L (2002) *Physica A* 314:663

RP

Quincke rotation — An effect where a particle, suspended in a fluid and subjected to a strong \rightarrow *electrostatic field*, spontaneously rotates [i]. \rightarrow *Quincke rotation* is thus a particular example of \rightarrow *electrorotation*. The onset of Quincke rotation occurs at a threshold value of the electrostatic field, which depends on such factors as the fluid viscosity and the dielectric charge relaxation times of the particle and the fluid (\rightarrow *dielectric relaxation*). Spontaneous rotation will occur only for the case where the charge relaxation time of the particle exceeds that of the surrounding fluid. The charge relaxation time of a material is given by the ratio of its permittivity and electrical conductivity, and so in general spontaneous rotation can occur if the particle is more polarizable than the surrounding fluid.

A simple phenomenological explanation of Quincke rotation is given in the Figure below. In (a) the case is shown where the charge relaxation time of the particle is lower than that of the fluid ($t_f > t_p$). The electric dipole moment (\rightarrow *dipole moment*) induced in the particle, as a result of the build-up of surface free charges, has the same orientation as the applied electric field E [ii, iii]. If the particle is given a slight, random, rotational displacement the resulting electric torque will restore the particle's orientation. On the other hand, if we have the case shown in (b) where the charge relaxation time inequality is reversed ($t_f < t_p$), the induced dipole moment opposes the applied field. A small rotational displacement of the particle produces a torque which tends to further push the particle away from its original orientation, and full rotational motion can be initiated if the electrical torque overcomes the viscous drag imposed by the fluid. The axis of rotation will always be perpendicular to the applied field, but the sense of rotation (clockwise or anti-clockwise) is dictated by the random nature of the initial displacement [iv] and may even exhibit chaotic behavior [v].

Quinhydrone electrode — introduced by \rightarrow *Büilmann* in 1921 [i–vi] is a \rightarrow *redox electrode* for \rightarrow *pH measurements* [vii, viii]. Quinhydrone is a sparingly soluble charge-transfer complex consisting of quinone and hydroquinone in 1:1 ratio. At an inert electron conductor (e.g., \rightarrow *platinum wire* or modified \rightarrow *graphite*) the following electrochemical equilibrium is established:

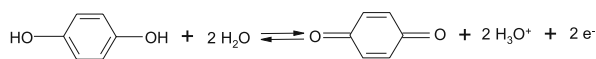

Quinhydrone electrode — Figure

The \rightarrow *potential* of this \rightarrow *redox electrode* (platinum, quinhydrone solution) depends on the ratio quinone to hydroquinone and on the pH of the solution:

$$E = E_{\text{Q/Q}^{2-}}^{\ominus} + (RT/2F) \ln(a_{\text{Q}}/a_{\text{Red}}) - (RT/2F) \ln(K_{a1}K_{a2}) + (RT/2F) \ln(a_{\text{H}_3\text{O}^+}^2 + K_{a1}a_{\text{H}_3\text{O}^+} + K_{a1}K_{a2})$$

($E_{\text{Q/Q}^{2-}}^{\ominus}$ is the standard potential of the system quinone (Q) and the dianion of hydroquinone (Q^{2-}), a_{Red} is the sum of the activities of all hydroquinone forms: $a_{\text{Red}} = a_{\text{H}_2\text{Q}} + a_{\text{HQ}^-} + a_{\text{Q}^{2-}}$, $K_{a1} = 1.75 \times 10^{-10}$ and $K_{a2} = 4 \times 10^{-12}$ are the \rightarrow *acidity constants* of hydroquinone, R is the \rightarrow *gas constant*, T is the absolute temperature, F is the \rightarrow *Faraday constant*). The ratio of quinone concentration to the sum of concentrations of all hydroquinone

forms is unity because of the composition of quinhydrone; however, strong oxidants or reductants may change that ratio; also, in emulsions a preferential dissolution of the quinone in the oil droplets may affect that ratio in the aqueous phase. For $\text{pH} < 9.5$ (i.e., at $\text{pH} < \text{p}K_{\text{a}1}$) the potential of the quinhydrone electrode follows the equation: $E(25^\circ\text{C}) = E_c^{\ominus'}(\text{quinhydrone}) - 0.059\text{pH}$ ($E_c^{\ominus'}(\text{quinhydrone})$ is the \rightarrow formal potential of the quinhydrone electrode at $\text{pH} < 9.5$. At 25°C the formal potential is 0.6995 V vs. SHE [ix]). The classic quinhydrone electrode requires to spoil the solution with some quinhydrone powder and to measure the potential of a platinum electrode in that solution versus a reference electrode [viii]. Recently it has been shown that composite electrodes containing modified graphite and quinhydrone can perform as well as the classical electrodes without spoiling the solutions

and additionally offering various new applications [x–xii].

Refs.: [i] Biilmann E (1921) *Ann Chim* 15:109; [ii] Biilmann E, Lund H (1921) *Ann Chim* 16:321; [iii] Biilmann E, Krarup I (1924) *J Chem Soc* 125:1954; [iv] Biilmann E, Jensen AL (1927) *Bull Soc Chim* 41:147; [v] Biilmann E, Jensen AL (1927) *Bull Soc Chim* 41:151; [vi] Biilmann E (1927) *Bull Soc Chim* 41:213; [vii] Galster H (1991) *pH-measurement: fundamentals, methods, applications, instrumentation*. Wiley-VCH, Weinheim; [viii] Clark WM (1928) *The determination of hydrogen ions*. Williams and Wilkins, Baltimore; [ix] Janz GJ, Ives DJG (1961) *The quinhydrone electrode*. In: Ives DJG, Janz GJ (eds) *Reference electrodes*. Academic Press, New York, pp 270; [x] Kahlert H, Steinhardt T, Behnert J, Scholz F (2004) *Electroanalysis* 16:2058; [xi] Scholz F, Steinhardt T, Kahlert H, Pörksen JR, Behnert J (2005) *J Chem Educ* 82:782; [xii] Kahlert H, Pörksen JR, Behnert J, Scholz F (2005) *Anal Bioanal Chem* 382:1981

HK

R

Radiance — Radiance L refers to the radiation that comes from an extended source. It corresponds to the power transmitted through a surface per unit area of that surface, per unit solid angle, given in $\text{W sr}^{-1} \text{m}^{-2}$.

Ref.: [i] Meyer-Arendt JR (1995) *Introduction to classical and modern optics*. Prentice-Hall, Englewood Cliffs

IH

Radical anion — is a molecule (mostly organic or coordination compound) after a one-electron reduction, having a charge of -1 , and bearing an unpaired electron, i.e., being paramagnetic.

JL

Radical cation — is a molecule (mostly organic or coordination compound) after a one-electron oxidation, having a charge of $+1$, and bearing an unpaired electron, i.e., being paramagnetic.

JL

Radio frequency polarography — This technique is based on the effect of \rightarrow *faradaic rectification*, which is a change of \rightarrow *electrode mean \rightarrow potential* under the influence of sinusoidal \rightarrow *alternating current* [i]. The excitation signal is a radio frequency sinusoidal alternating current (e.g., 400 kHz) which is 100% amplitude-modulated by a square-wave frequency of 225 Hz [ii]. To keep the mean potential constant, a low-frequency alternating current has to be supplied to the electrode. The amplitude of this current depends on the radio frequency and the \rightarrow *kinetics of electrode reaction* [iii]. If the mean potential is controlled by the \rightarrow *potentiostat* and slowly changed as in \rightarrow *DC polarography*, the response is an S-shaped current–potential curve characterized by a maximum and a minimum [iv]. The absolute value of the ratio of peak currents ($R = i_{\text{max}}/i_{\text{min}}$) depends on the \rightarrow *charge-transfer coefficient* ($|R| > 1$ if $\alpha < 0.5$ and $|R| < 1$ if $\alpha > 0.5$), while the amplitude ($i_{\text{max}} - i_{\text{min}}$) depends on the standard rate constant of the \rightarrow *electrode reaction* [v]. The technique was used for the determination of kinetic parameters of very fast electrode reactions ($k_s > 0.1 \text{ cm s}^{-1}$) [ii, iii, v]. Under the influence of the reactant adsorption on the surface of the DME, the RF polarogram of the reduction becomes highly asymmetrical ($|R| \ll 1$) and may exhibit only a minimum [v, vi]. So, anion-induced adsorption of metal complexes restricts the kinetic measurements. Peak currents of both

the maximum and minimum are linearly proportional to the bulk concentration of a depolarizer. This is the basis for analytical application of the method [vi].

Refs.: [i] Doss KSG, Agarwal HP (1950) *J Scient Ind Res* 9B:280; [ii] Barker GC, Faircloth RL, Gardner AW (1958) *Nature* 181:247; [iii] Agarwal HP (1971) *Electrochim Acta* 16:1395; [iv] Barker GC (1961) *Faradaic rectification*. In: Yeager E (ed) *Transactions of the symposium on electrode processes*, Wiley, New York, p 325; [v] Barker GC (1958) *Anal Chim Acta* 18:118; [vi] Lovrić M, Komorsky-Lovrić Š, Branica M (1992) *Chem Analit* 37:313

MLo

Radiochemical (nuclear) methods in electrochemistry

— Radiochemical methods are applied for the study of a wide range of electrochemical surface processes. The most important areas are as follows: \rightarrow *adsorption* and \rightarrow *electrosorption* occurring on the surface of electrodes; the role of electrosorption in \rightarrow *electrocatalysis*; \rightarrow *deposition* and dissolution of metals; \rightarrow *corrosion* processes; the formation of surface layers, films on electrodes (e.g., polymer films), and investigation of migration processes in these films; study of the dynamics of \rightarrow *electrosorption* and \rightarrow *electrode processes* under steady-state and equilibrium conditions (exchange and mobility of surface species); electroanalytical methods (e.g., radiopolarography).

The most important techniques are: \rightarrow *tracer methods* (i), Mössbauer spectroscopy (ii), neutron activation (iii), thin layer activation (TLA) (iii), ultrathin layer activation (UTLA) (iii), and positron lifetime spectroscopy (iv).

Refs.: [i] Horányi G (1999) *Radiotracer studies of adsorption/sorption phenomena at electrode surfaces*. In: Wieckowski A (ed) *Interfacial electrochemistry, theory, experiment, and applications*. Marcel Dekker, New York, pp 477–491; [ii] Kálmán E, Lakatos M, Kármán FH, Nagy F, Klencsár Z, Vértés A (2005) *Mössbauer spectroscopy for characterization of corrosion products and electrochemically formed layers*. In: Freund HE, Zewi I (eds) *Corrosion reviews*. Freund Publishing House, Tel Aviv, pp 1–106; [iii] Horányi G, Kálmán E (2005) *Recent developments in the application of radiotracer methods in corrosion studies*. In: Marcus PH, Mansfeld F (eds) *Analytical methods in corrosion science and engineering*. CRC Press, Boca Raton, pp 283–333; [iv] Süvegh K, Horányi TS, Vértés A (1988) *Electrochim Acta* 33:1061

GH

Radiotracer methods \rightarrow tracer methods

Ragone diagram — Plot of \rightarrow *power density* vs. \rightarrow *energy density* (or vice versa) for electrochemical \rightarrow *power sources*. As shown below (actual data may vary depending on source and time of data acquisition) a broad vari-

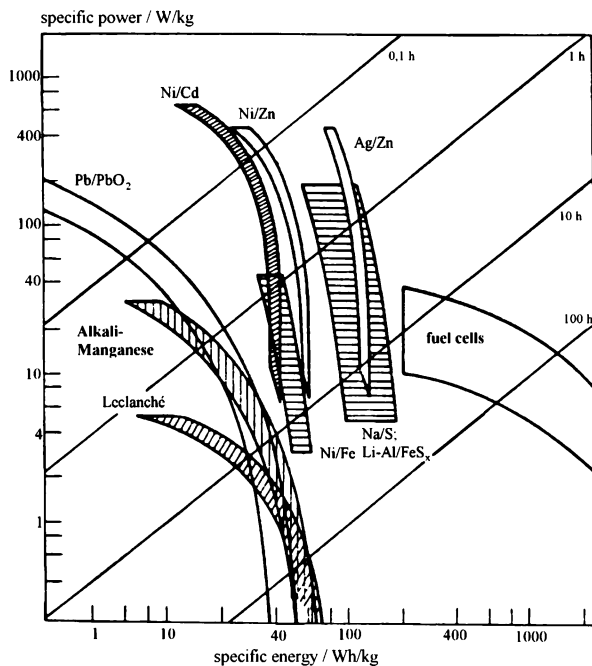

Ragone diagram — Figure. Ragone plot for selected electrochemical energy conversion and storage systems

ety of possible power and energy density exists. The additional lines refer to discharge times, i.e., the time formally required to convert all \rightarrow active mass or to fully discharge the cell to the discharge cutoff voltage. In other displays similar lines indicate the range (maximum traveling distance) for an electric vehicle operating under specified conditions.

Refs: [i] Kordesch G, Simader G (1996) *Fuel cells and their applications*. VCH, Weinheim; [ii] Holze R (1989) *Leitfaden der Elektrochemie*. Teubner, Stuttgart

Randles, John Edward Brough



(Aug. 26, 1912, England – Feb. 13, 1998, England) Randles was one of the founders of dynamic electrochemistry. He was educated at Derby School and Cambridge

University. During the second world war, Randles was a conscientious objector, and was allocated to a research establishment. In 1945 he was appointed Lecturer at Birmingham University (U.K.), and remained there for the rest of his scientific career. Archie Hickling had invented the \rightarrow potentiostat in 1942, but it was an essentially static device. John Randles built a dynamic version which he reported in 1947 [i]. This was a cathode ray polarograph that had a synchronizing circuit to give exact control of the time lag between the fall of a mercury drop and the start of a linear voltage sweep. Within a year, Randles in England [ii] and Augustin \rightarrow Ševčík in Czechoslovakia [iii] had independently developed linear sweep voltammetry and derived an expression for the current-voltage response of a diffusion-controlled electrode reaction. Today, this landmark result is known as the \rightarrow Randles–Ševčík equation. Many modern techniques of electrochemistry are descended from this work, including \rightarrow cyclic voltammetry, \rightarrow anodic stripping voltammetry, and various types of \rightarrow hydrodynamic voltammetry. At the Faraday Discussion of 1947 Randles described the \rightarrow impedance of a circuit containing both diffusion and interfacial electron transfer, and showed that the mathematical couplings between \rightarrow diffusion, \rightarrow electron transfer, and solution \rightarrow resistance could be represented by an equivalent circuit of linear components [iv]. This opened the way to the study of fast electrode reactions, and laid the groundwork for the future field of AC \rightarrow impedance. At the same meeting, a communication from Boris Ershler [v] revealed that parallel developments were in progress in the Soviet Union. Today, the “Randles–Ershler equivalent circuit” (\rightarrow Randles–Ershler impedance) remains one of the most widely used models of electrochemical impedance, typically including a double layer capacitor and a charge transfer resistance in parallel, and a solution resistance in series. In 1952, Randles realized that thermal fluctuations were required in the atomic coordinates of reactant species and their solvation shells, before electron transfer could take place [vi]. This epochal idea was illustrated with a plot of potential energy versus reaction coordinate, and remains today as the cornerstone of modern electron transfer theory. Besides his theoretical insights, Randles was a first-class experimentalist. His measurement of the \rightarrow Volta potential difference between mercury and aqueous solution remains a classic [vii]. This experiment generated estimates of the absolute hydration enthalpy of the proton, $\Delta H_{\text{aq}}^{\circ}(\text{H}^+)$, which averaged about $-1131 \text{ kJ mol}^{-1}$. Modern estimates [viii] place the true value at $-1150 \pm 10 \text{ kJ mol}^{-1}$, remarkably close to Randles’ value.

RH

Refs.: [i] Randles JEB (1947) *Analyst* 72:301; [ii] Randles JEB (1948) *Trans Faraday Soc* 44:327; [iii] Ševčík A (1948) *Coll Czech Chem Commun* 13:349; [iv] Randles JEB (1947) *Discuss Faraday Soc* 1:11; [v] Ershler BV (1947) *Discuss Faraday Soc* 1:269; [vi] Randles JEB (1952) *Trans Faraday Soc* 48:828; [vii] Randles JEB (1956) *Trans Faraday Soc* 52:1573; [viii] Tissandier MD, Cowen KA, Feng WY, Gundlach E, Cohen MJ, Earhart AD, Coe JV (1998) *J Phys Chem A* 102:7787

SF

Randles–Ershler impedance → impedance

Randles semicircle — When subjected to small amplitude perturbations, it is often found that electrochemical systems respond in a manner that is both linear and homogeneous. That is to say, they behave in such a way that the output from two simultaneously-applied perturbations is identical to the sum of the outputs of each perturbation applied independently. When this is the case, the “principle of superposition” is said to hold, and the electrochemical system may be modeled by a set of linear circuit elements arranged in an equivalent circuit. The special value of equivalent circuits is that they permit many of the tools of electric circuit theory (such as the Laplace transform and the Fourier transform) to be applied to the modeling process. A further advantage is that small-amplitude data may be analyzed (and visualized) in the complex plane of → *impedance*, which gives rise to the field of → *electrochemical impedance spectroscopy*. A widely applicable equivalent circuit is known as the → *Randles–Ershler impedance*. In the absence of diffusion control, the Randles–Ershler impedance generates a highly characteristic “Randles semicircle” in the first quadrant of the → *complex plane plot* (electrochemical convention), indicating the presence of a charge transfer reaction in parallel with the charging of the electrochemical → *double layer*.

SF

Randles–Ševčík equation — An equation introduced by → *Randles* [i] and → *Ševčík* [ii] describing the magnitude of the voltammetric peak current I_p (in → *linear scan voltammetry* or in → *cyclic voltammetry*) for a reversible electron transfer (E_{rev} mechanism → *E_{rev} diagnostics in cyclic voltammetry*).

$$I_p(E_{rev}) = 0.446n^{3/2}FAc\sqrt{\frac{FvD}{RT}}$$

In this equation the peak current I_p is given by n the number of electrons transferred per molecule diffusing to the electrode surface, F the → *Faraday constant*, A the

electrode area, c the bulk concentration, v the scan rate, D the → *diffusion coefficient*, R the → *gas constant*, and T the absolute temperature.

Similar equations can be derived for the peak current for voltammetric responses for irreversible electron transfer (E_{irrev} mechanism → *E_{irrev} diagnostics in cyclic voltammetry*) or for other mechanistic cases.

$$I_p(E_{irrev}) = 0.496\sqrt{\alpha n'}nFAc\sqrt{\frac{FvD}{RT}}$$

In this equation α denotes the → *transfer coefficient* and n' is the number of electrons transferred in the rate-determining reaction step. All Randles–Ševčík-type expressions have in common a $I_p \propto \sqrt{D}$ dependence which is indicative of diffusion control [iii].

Refs.: [i] Randles JEB (1948) *Trans Faraday Soc* 44:327; [ii] Ševčík A (1948) *Coll Czech Chem Commun* 13:349; [iii] Marken F, Neudeck A, Bond AM (2000) *Cyclic voltammetry*. In: Scholz F (ed) *Electroanalytical methods*. Springer, Berlin, pp 51

FM

R

Range

- ~ of measurements: The difference between the highest and the lowest result of a set of replicate measurements [i].
- ~ of a procedure: The interval between the upper and lower concentration of → *analyte* that can be determined with suitable levels of → *precision* and → *accuracy* in a → *sample* [i].

Ref.: [i] Skoog D, West D, Holler F, Crouch SR (2003) *Fundamentals of analytical chemistry*. 8th edn. Brooks/Cole, Belmont

FG

Rate coefficient → reaction rate

Rate constant → reaction rate

Rate-determining step — An overall chemical reaction usually involves several consecutive steps, e.g.,



where A is the reactant, D is the product, and B, C are intermediates. The “slowest” step is the rate-determining step (rds) of the reaction. Although the expression “lowest” is often used, it is better to speak of the “most hindered” step or the step of the smallest → *rate coefficient* (see → *reaction rate*). The most hindered step is not necessarily a chemical transformation. In the case of

→ *electrode processes* the rate-determining step is often a → *mass transport process* (→ *diffusion*). Any step of an → *electrode reaction*, i.e., the → *charge transfer*, → *adsorption*, chemical reaction or structural reorganization (see → *Marcus theory*) etc. can be the most hindered process, and consequently the rate-determining step. The rate of the elementary reactions (reaction steps) of any consecutive reaction depends on the experimental parameters. By varying the temperature, the rate-determining step may change if the values of the → *activation energy* of the corresponding steps differ. In electrochemistry temperature variation is less often applied; the unique tool of electrochemists is the variation of the → *electrode potential* (see → *overpotential*, → *activation overpotential*). The rate of the mass transport step can be accelerated by stirring of the solution (see → *convection*, → *rotating disk electrode*, → *rotating ring disc electrode*, → *ultrasound*, → *vibrating electrode*) or by the application of a proper → *electrode design* (see e.g., → *microelectrodes*, → *ultra-microelectrodes*, → *porous electrodes*, → *fuel cells*). In this way for a given electrode process the actual rds may depend on the choice of the chemical, electrical, and physical experimental or industrial conditions.

R

Rate of an electrochemical reaction → *reaction rate*

Rate of migration (in electrophoresis), ν — The distance of migration divided by time, sometimes called → *velocity* of migration. The symbol ν is also used for velocity.

Ref.: [i] Riekkola ML, Jönsson JÅ, Smith RM (2004) *Pure Appl Chem* 76:443

GI

WK

Rational potential → *potential*

RDE → *rotating disk electrode*

Reactance — In → *alternating current* (AC) measurements, reactance is the imaginary part of → *impedance* given by:

$$Z = R + iX,$$

where Z is the impedance [$\Omega \text{ m}^2$], R the → *resistance* [$\Omega \text{ m}^2$], X the reactance [$\Omega \text{ m}^2$], and i is the imaginary unit ($i = \sqrt{-1}$). When an electrical circuit is composed of passive elements (resistors, inductors, and capacitors), the reactance of the circuit is attributed to capacitors and inductors. In → *electrochemical impedance spectroscopy*, an equivalent electrical circuit is often utilized to simulate the frequency dependence of a given electrodic process or electrical double-layer charging. The equivalent

circuit is composed of passive elements. In general, the reactance is given by:

$$X = X_C - X_L,$$

where X_C is the capacitive reactance and X_L is the inductive reactance. For a series inductor–capacitor connection, the capacitive reactance:

$$X_C = 1/(\omega C) = 1/(2\pi f C),$$

is due to the capacitance C of the capacitor measured in [F m^{-2}], and the inductive reactance:

$$X_L = \omega L = 2\pi f L$$

is due to the inductance L of the inductor measured in henries [H m^2], ω is the angular frequency of the AC signal [rad s^{-1}], and f is the frequency [Hz].

The non-zero reactance of an equivalent electric circuit results in a phase shift ϕ , which is a difference in the phase of an AC current and AC voltage:

$$\tan \phi = (X_C - X_L)/R.$$

The predominant capacitive behavior of a given circuit at a given frequency ω will cause a positive phase shift, where current leads voltage by the phase difference ϕ . The predominant inductive behavior of a circuit at frequency ω will cause a negative phase shift, where current lags voltage by the phase difference ϕ .

Refs.: [i] Bard AJ, Faulkner LR (2001) *Electrochemical methods*, 2nd edn. Wiley, New York; [ii] Macdonald JR (1987) *Impedance spectroscopy*. Wiley, New York

MHep

Reaction layer thickness — An electrochemical reaction (e.g., → *hydrogen evolution reaction* (HER)) may be associated with a preceding chemical reaction (i.e., dissociation of a weak acid in this example) according to

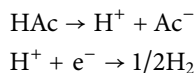

with HAc acetic acid, Ac^- acetic acid anion. The acid dissociation proceeds mostly in a layer adjacent to the electrode|electrolyte interface wherein the → *equilibrium* between the acid and its dissociation products is significantly disturbed by proton consumption of the HER. The acid concentration decreases slowly upon approaching the interface as depicted below. As the acid itself is not consumed in the HER the acid concentration can be assumed to be constant in very close vicinity

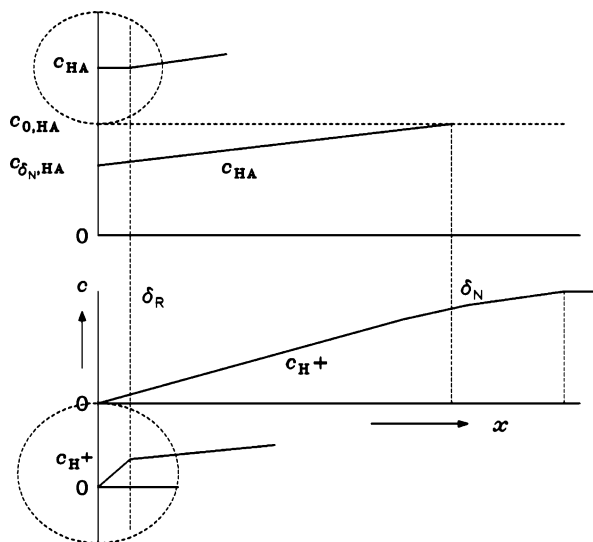

Reaction layer thickness — Figure. Concentration gradients at the electrode/solution interface

of the interface (see inset). The corresponding \rightarrow *diffusion layer* δ_N is indicated. The concentration of the protons is significantly lower, the respective concentration gradient is also indicated, and it extends slightly more into the bulk of the solution because of the dissociation equilibrium. In a very thin layer, protons generated by dissociation are consumed faster than they might escape back into solution. In this layer the proton concentration drops rapidly to zero. This layer is called reaction layer with thickness δ_R . In the discussed example the thickness is given by

$$\delta_R = \sqrt{\frac{D_{H^+}}{k_b c_{A^-}}}$$

with the diffusion of the protons D_{H^+} , the rate constant of the recombination reaction k_b , and the acid anion concentration c_{A^-} .

RH

Reaction overpotential — When a slow (strongly hindered) chemical reaction is coupled to a fast (reversible) \rightarrow *charge transfer* step an \rightarrow *overpotential* is needed to drive the \rightarrow *electrode reaction* with a given rate. This is termed the reaction overpotential, η_r [i-iv]. It is associated with the decreased concentration of the electrochemically active species at the interface [$c(x=0)$] relative to its bulk concentration (c^*) due to the chemical equilibria between the electroactive and electroinactive forms of the reacting compound. The chemical reaction

which affects the rate of the \rightarrow *electrode process* may occur before or after the charge transfer step:



where O and R the oxidized and reduced forms of the redox couple participating in the electrode reaction, B is the inactive form of R, and ν is the order of reaction.

In order to derive the equation for pure reaction overpotential we assume that j_o is high, i.e., an equilibrium exists at the electrode metal surface in respect of the surface concentrations of O and R. All other steps including diffusion are fast enough, i.e., much faster than reaction (2). (In general, η is a sum of different contributions [\rightarrow *activation overpotential*, \rightarrow *diffusion overpotential* etc.] which might be interdependent.)

For reactions (1) and (2)

$$\eta_r = E - E_e = \frac{RT}{nF} \ln \frac{c_R^* c_O(x=0)}{c_O^* c_R(x=0)}, \quad (3)$$

where E and E_e are the electrode potential and the equilibrium potential, respectively. Assuming that concentrations c_O^* and c_B^* are high and do not change during the experiment, and $c_O^* = c_O(x=0)$ and $c_B^* = c_B(x=0)$:

$$j = \nu n F \left[\bar{k}_2 c_B^* - \bar{k}_2 c_R^\nu(x=0) \right], \quad (4)$$

where \bar{k}_2 and \bar{k}_2 are the \rightarrow *rate coefficients* of reaction (2). If the electrode process takes place into the direction of oxidation, at high enough \rightarrow *current density* (j) $c_R(x=0) \rightarrow 0$, consequently

$$\bar{k}_2 c_B^* \gg \bar{k}_2 c_R^\nu(x=0) \quad (5)$$

and the reaction \rightarrow *limited current* can be obtained:

$$j_{L,R} = \nu n F \bar{k}_2 c_B. \quad (6)$$

It can be seen that – in contrast with the diffusion-limited current – the reaction-limited current does not depend on the hydrodynamical conditions. At intermediate overpotentials

$$j = j_{L,R} - \nu n F \bar{k}_2 c_R^\nu(x=0). \quad (7)$$

It follows that

$$\frac{c_R^*}{c_R(x=0)} = \left(1 - \frac{j}{j_{L,R}} \right)^{-1/\nu} \quad (8)$$

and

$$\eta_r = -\frac{RT}{\nu nF} \ln \left(1 - \frac{j}{j_{L,R}} \right) = \frac{\nu RT}{nF} \ln \frac{c_R^*}{c_R(x=0)}. \quad (9)$$

At $j_{L,R} \ll |j|$, i.e., at high cathodic polarization

$$\eta = \frac{RT}{\nu nF} \ln j_{L,R} - \frac{RT}{\nu nF} \ln |j| \quad (10)$$

and from the constant b ($b = RT/\nu nF$) of the respective \rightarrow Tafel plot, ν , the order of reaction can be calculated. At high anodic polarization reaction-limited current is observed.

Typical examples are the dissociation of weak acids either in reaction of hydrogen evolution or regarding their oxidation when only the protonated forms are electroactive (e.g., oxalic acid) as well as the reduction of formaldehyde whose hydrate existing in aqueous solutions is electroinactive.

Refs.: [i] Hamann CH, Hamnett A, Vielstich W (1998) *Electrochemistry*. Wiley-VCH, Weinheim, pp 145, 182–186; [ii] Cauquis G (1983) *Basic concepts*. In: Baizer MM, Lund H (eds) *Organic electrochemistry*. Marcel Dekker, New York, pp 38–48; [iii] Erdey-Grúz T (1972) *Kinetics of electrode processes*. Akadémiai Kiadó, Budapest, pp 29, 81–95; [iv] Vetter KJ (1951) *Z Elektrochem* 55:121

R

Reaction rate — The (instantaneous) rate of a reaction can be expressed by the derivative of any quantity X , which changes during a chemical reaction, with respect to time [i].

$$\dot{X} = dX/dt. \quad (1)$$

X may be the number of molecules, the number \rightarrow concentration, the amount concentration, pressure, \rightarrow entropy etc.

The reaction must be specified for which this quantity applies, by giving stoichiometric equation.

In chemistry most often the reaction rate based on amount concentration is used in the case of homogeneous reaction at a constant volume V :

$$v_c = \nu_i^{-1} dc_i/dt = \dot{\xi}/V, \quad (2)$$

where v_c (or simply ν) is the rate of reaction based on the amount concentration ($\text{mol m}^{-3} \text{s}^{-1}$), ν_i is the stoichiometric coefficient of entity i , c_i is the amount concentration (mol dm^{-3}) related to the species i , t is time (s), ξ is the extent of reaction (advancement) (mol); $\dot{\xi} = d\xi/dt$ is the rate of conversion (mol s^{-1}).

Less frequently the reaction rate v_c ($\text{m}^{-3} \text{s}^{-1}$) based on the number concentration C_i (m^{-3}) is also used:

$$v_c = \nu_i^{-1} dC_i/dt. \quad (3)$$

In \rightarrow flow cells, effects due to input and output processes must be taken into account separately, as well as transport processes in general by the equation as follows

$$(dc_i/dt)_{\text{total}} = (dc_i/dt)_{\text{reaction}} + (dc_i/dt)_{\text{transport}}. \quad (4)$$

In order to obtain unambiguous and comparable values for the reaction rates of heterogeneous (interfacial) reactions including electrode reactions the overall rate is related to the unit area of the interface, i.e., to the real surface area (A_r) (\rightarrow electrode surface area) of the electrode. Therefore, the unit of ν of interfacial reactions is $\text{mol m}^{-2} \text{s}^{-1}$.

The rate of the reactions is characterized by the rate coefficient or rate constant (k) which involves all dependences of ν except its variation with the concentrations:

$$\nu = k \prod_i c_i^{m_i}, \quad (5)$$

where m_i is the partial order of reaction, and $m = \sum_i m_i$ is the overall order of reaction. The unit of k is $(\text{m}^3 \text{mol}^{-1})^{m-1} \text{s}^{-1}$. The rate coefficient usually strongly depends on temperature. The variation of k with temperature is connected with the \rightarrow activation energy (enthalpy of activation, Gibbs energy of activation), and is phenomenologically described by the \rightarrow Arrhenius equation or by other empirical equations which are also being used.

The rate constant can be expressed by using molecular, statistical mechanical, and thermodynamical quantities, functions, and formulations. For instance, in the transition state theory of chemical reactions for an elementary reaction

$$k = \kappa (k_B T/h) \exp(-\Delta^\ddagger G^\ominus/RT), \quad (6)$$

where κ is the transmission coefficient, k_B is the \rightarrow Boltzmann constant, h is the \rightarrow Planck constant, R is the molar \rightarrow gas constant, T is temperature, and $\Delta^\ddagger G^\ominus$ is the standard free energy of activation.

In electrochemistry the potential dependence of k is of primary importance [ii–v].

The relationship between the \rightarrow current density (j) and reaction rate related to unit surface (ν) is as follows:

$$j = nF\nu, \quad (7)$$

where n is the \rightarrow charge number of the electrochemical reaction and F is the \rightarrow Faraday constant. There are

two potential-dependent rate constants, the reduction rate constant (k_{red}) and the oxidation rate constant (k_{ox}) which are related to the \rightarrow cathodic (j_c) and \rightarrow anodic (j_a) partial currents, respectively:

$$k_c = -\frac{j_c}{nF\pi[c_i(x=0)]^{m_i}} \quad (8)$$

and

$$k_a = -\frac{j_a}{nF\pi[c_i(x=0)]^{m_i}}, \quad (9)$$

where $c_i(x=0)$ is the concentration of the electrochemically active species i at the interface ($x=0$). For a first-order reaction the SI unit of k_c and k_a is m s^{-1} .

We may collect all the potential-independent terms in the standard rate constant (k_s):

$$k_s = \frac{k_{\text{red}}}{\exp[-\alpha_c n f (E - E_c^{\ominus'})]} = \frac{k_{\text{ox}}}{\exp[\alpha_a n f (E - E_c^{\ominus'})]}, \quad (10)$$

where α_c and α_a are the cathodic and anodic \rightarrow transfer coefficients, respectively, E is the potential, $E_c^{\ominus'}$ is the \rightarrow formal potential of the electrode reaction and $f = F/RT$. The relationship between k_s and the \rightarrow exchange current density (j_0) is

$$j_0 = nFk_s c_{\text{ox}}^{(1-\alpha_c)} c_{\text{red}}^{\alpha_c} \quad (11)$$

if $c_{\text{ox}} = c_{\text{red}} = c^*$

$$j_0 = nFk_s c^* \quad (12)$$

When the \rightarrow charge transfer step is coupled to diffusion it is useful to introduce a rate constant-like quantity to characterize the rate of diffusion. It is the mass transport coefficient (k_{m_i})

$$k_{m_i} = D_i/\delta_i, \quad (13)$$

where D_i is the \rightarrow diffusion coefficient of species i , and δ_i is the \rightarrow diffusion layer thickness related to species i . The unit of k_{m_i} is m s^{-1} .

Refs.: [i] Cohen ER, Cvitas T, Frey JG et al. (eds) (2006) IUPAC quantities, units and symbols in physical chemistry, pp 47–75; [ii] Inzelt G (2002) Kinetics of electrochemical reactions. In: Scholz F (ed) Electroanalytical methods. Springer, Berlin, pp 29–49; [iii] Bard AJ, Faulkner LR (2001) Electrochemical methods, 2nd ed. Wiley, New York; [iv] Parsons R (1980) Pure Appl Chem 52:233; [v] Parsons R (1974) Pure Appl Chem 37:499

Reactive power \rightarrow power (electrical)

Reagentless biosensors \rightarrow biosensors

Real electrode area \rightarrow electrode surface area

Real part of impedance \rightarrow impedance

Real power \rightarrow power (electrical)

Rechargeable battery \rightarrow battery

Rectification — is defined as the conversion of \rightarrow alternating current, AC, into pulsating \rightarrow direct current, DC, by any means other than the use of a motor-generator. That is, the AC is primarily converted by use of a \rightarrow rectifier into (unfiltered) unidirectional half-cycles. The percentage ratio of the DC output voltage to the peak AC input voltage of a certain rectifier device is called rectification efficiency. A circuit containing parallel \rightarrow capacitance, sometimes in combination with series inductance, is afterwards frequently applied as rectification filter in order to smooth the ripple in the DC current output. A combined device of rectifier and filter is called rectifier-filter system.

Ref.: [i] Gibilisco S (2001) The illustrated dictionary of electronics. McGraw-Hill/TAB Electronics, p 588

MHer

Rectifier — The rectifier is an electronic or electromechanical device, that converts \rightarrow alternating current, AC, into pulsating (rectified) \rightarrow direct current, DC (see: \rightarrow rectification). A frequently used rectifier in power supplies is the rectifier diode, i.e., a heavy-duty tube or semiconductor diode. In high-voltage, high-current power supplies, in earlier times two-element electron tubes, or rectifier tubes, were commonly used. Usually, an assembly of separated rectifier disks or plates is connected in series on a central bolt as so-called rectifier stack. A rectifier probe is a diode-type probe used with a DC voltmeter to measure radiofrequency (RF) voltage. The diode rectifies the RF signal and a DC voltage, proportional to the peak RF voltage, is indicated by the voltmeter.

Ref.: [i] Gibilisco S (2001) The illustrated dictionary of electronics. McGraw-Hill/TAB Electronics, p 588

MHer

Recursive filter — A sort of \rightarrow analog filter or \rightarrow digital filter based on employing feedback to determine the current filtered output. In digital filters, the software technique is based on calculating the current filtered output (y_n) from input values ($x_n, x_{n-1}, x_{n-2}, \dots$) and previous filtered outputs (y_{n-1}, y_{n-2}, \dots). Thus, previously calculated output values go back into the calculation of the

GI

latest output. Generally, recursive filters are faster than a \rightarrow *nonrecursive filter* of similar performance, since the former require a lower-order filter and thus, involve less computing resources than the equivalent \rightarrow *nonrecursive filter*. On the other hand, high-order recursive filters may present instabilities related to the arithmetic algorithm employed. The order of a recursive filter (n) is given by the largest number of previous input or output values used to calculate the current output. Thus, a set of $(2n + 1)$ coefficients can be assigned to each input and output value. These coefficients join the following filter specifications: filter type (low-pass, band-pass, etc.), cutoff and sampling frequencies, smoothing function (Gaussian, Butterworth, Chebyshev, Bessel, Elliptic, etc.). Filtered data can be obtained by the convolution of inputs with the set of coefficients [i, ii].

Refs.: [i] Oppenheim AV, Schaffer RW (1999) *Discrete-time signal processing*. Prentice-Hall, New Jersey; [ii] Antoniou A (1993) *Digital filters: analysis, design, and applications*. McGraw-Hill, New York

R

Redox battery \rightarrow *battery*

Redox buffer \rightarrow *buffer*

Redox center — Whereas the localization of changes in state of oxidation, number of electrons in atom orbitals etc. are obvious and well-defined for single-atom ions, this is rarely self-evident in polyatomic species. In the extreme case of intrinsically \rightarrow *conducting polymers* the injected charge is distributed (delocalized) over several repeated units in the polymer strand. Frequently the change of electron distribution etc. affected by a redox process can be localized at functional groups, metal ions in complexes, coordination compounds, or metal-organic compounds. These sites are called redox centers, in particular when the electron transfer is reversible (i.e., a reduction may be followed by a reoxidation resulting in the initial species or vice versa).

RH

Redox centers; interaction between — In molecules having more than one electrochemically active (i.e., oxidizable or reducible) entity (metal ion in coordination group, functional group in organic compounds, \rightarrow *redox center*), such as in the polymer poly(vinylferrocene) with multiple oxidizable ferrocene centers on a single polymer chain, the electrochemical processes involving the respective entity may proceed without any influence of one redox center on the other (no interaction, sometimes also called no communication) or may involve significant interactions among the centers. In the case of no interaction, the

electron transfer to each redox center occurs at the same microscopic potential and close to that for the potential of the compound that contains only a single redox center. The overall stepwise potentials for the centers in a compound however differ because of entropic factors, with the result that the voltammetric wave for a 1-electron reaction at each of the n centers resembles that of a 1-electron wave but with a height characteristic of the n centers [i–iii]. If there are significant interactions, reductions become progressively more negative and oxidations more positive for the subsequent waves, because of largely electrostatic effects.

An example of no interaction is the reduction of one metal ion in a bimetallic coordination compound that occurs at an \rightarrow *electrode potential* as that of a similar molecule having only a single metal ion. According to the classification suggested by Robin and Day [iv] this system is called a class I system. On the contrary, when a process at one redox center causes a significant shift of the electrode potential for the second process at the other center, this system is called a class III system. Systems somewhere in between are assigned to class II. Interaction between the involved sites may proceed via conjugated bond systems, but also via electrostatic effects. In a typical example the reduction potentials of two metal ions of the same element (homobimetallic compound) may be observed at nearly the same potential in a class I system, whereas in a class III system the reduction of one metal ion causes a considerable shift of the reduction potential of the second ion to a more negative value of the electrode potential because of significant interactions between the groups. These interactions are also frequently studied spectroscopically.

Refs.: [i] Bard AJ, Faulkner LR (2001) *Electrochemical Methods*, Wiley, NY, p 506; [ii] Ammar F, Saveant JM (1973) *J Electroanal Chem* 47:215; [iii] Flanagan JB, Margel S, Bard AJ, Anson FC (1978) *J Am Chem Soc* 100:4248; [iv] Robin MB, Day P (1967) *Adv Inorg Radiochem* 10:247

RH, AJB

Redox couple — is a pair of molecules (ions) which differ in one or more electrons (charge number of the ion) ($M^{n+}/M^{(n-1)+}$; $M^{n+}/M^{(n-2)+}$; $A/A^{\bullet-}$; $D/D^{\bullet+}$; Py^+/Py^{\bullet} ; $X^{\bullet-}/X^{2-}$ etc.). Examples are: Fe^{2+}/Fe^{3+} ; ferrocene/ferrocenium, $Ar-NO_2/Ar-NO_2^{\bullet-}$; $[Ru(bipy)_3]^+/[Ru(bipy)_3]^{2+}$; etc.

JL

Redox electrode — Generally, any \rightarrow *electrode* system in which species with different oxidation states are involved. However, the term is usually applied in a more confined way to systems consisting of an inert electron

conductor (e.g., a noble metal like platinum) and an adjacent liquid electrolyte solution (or → *solid electrolyte*) **which contains both the oxidized and reduced form of a redox system**. See also → *hydrogen electrode* and the → *quinhydrone electrode*.

HK, FS

Redox equilibrium → *equilibrium*, subentry → *redox equilibrium*

Redox mediator — A redox mediator is a chemical compound M (a) that can shuttle → *electrons* between two other chemical compounds A and B in solution (for kinetic reasons A and B are not able to exchange electrons with each other; however, the reactions of M with A and M with B have to be unhindered), or (b) a chemical compound M that can shuttle electrons between an → *electrode* and a chemical species A in solution. In the latter case the mediator M is necessary when the → *electron transfer* reaction of A at the electrode is electrochemically irreversible. In case (a) the mediator is a homogeneous redox catalyst, whereas in case (b) the mediator acts as catalyst in a heterogeneous charge transfer reaction. Redox enzymes are typical mediators (catalysts) employed both in heterogeneous and homogeneous systems. Mediator is also sometimes used for a redox species that can shuttle charge between two electrodes, for example, in → *scanning electrochemical microscopy*.

See also → *bifunctional mediator*, → *biofuel cells*, → *catalytic current*, → *catalytic hydrogen evolution*, → *dye cell*, → *enzyme electrodes*, → *ferrocene*, → *glucose sensor*, → *indirect and direct electrolysis*, and → *surface-modified electrodes*.

FS

Redox mixed phases — are phases containing both the reduced and the oxidized form of a redox species. Whereas this case is trivial for liquid electrolyte solutions, it is of special significance for solid materials. In solid phases under → *equilibrium* conditions, this phenomenon requires a presence of variable-valence → *ions*. The → *reduction* or → *oxidation* of these ions is accompanied with → *intercalation/de-intercalation* of other charged species or oxidation/reduction of other variable-valence ions, in order to maintain → *electroneutrality*. The former situation requires a non-negligible concentration range where the corresponding → *solid solutions* exist (see also: → *defects in solids*, → *doping*, → *Wagner factor*). Formation of non-equilibrium → *redox couples* in solid materials may be

associated with various external forces such as → *electrochemical potential* gradients, → *electromagnetic fields*, → *interfacial* processes at the → *surface* and at → *grain boundaries*, → *charge injection*, radiation etc. Examples are partly reduced or partly oxidized metal polycyanometalates [i–ii], oxides, positive electrode materials of rechargeable → *lithium batteries* [iii], and numerous → *mixed ionic–electronic conductors*, particularly transition metal-containing → *perovskites* and → *pyrochlores* [iv–v]. In many cases such as → *cerium dioxide*, the → *electrolytic permeability* of → *solid electrolytes* originates from the appearance of redox mixed phases.

Refs.: [i] Scholz F, Kahlert H (2006) *Electrochemistry of polycyanometalates*. In: Bard AJ, Stratmann M, Scholz F, Pickett CJ (eds) *Inorganic electrochemistry*. Encyclopedia of electrochemistry, vol. 7b. Wiley-VCH, Weinheim; [ii] Scholz F, Lovrić M, Stojek Z (1997) *J Solid State Electrochem* 1:134; [iii] Rahner D, Machill S, Schlörb H, Siury K, Kloss M, Plieth W (1998) *J Solid State Electrochem* 2:78; [iv] Kharton VV, Yaremchenko AA, Naumovich EN (1999) *J Solid State Electrochem* 3:303; [v] Kharton VV, Tsipis EV, Yaremchenko AA, Vyshatko NP, Shaula AL, Naumovich EN, Frade JR (2003) *J Solid State Electrochem* 7:468

FS, VK

Redox-modified enzymes — In enzymes the redox-active prosthetic group such as FAD, PQQ, heme, iron-sulfur clusters etc. are isolated from the surroundings by the protein shell. This is essential to prevent unwanted redox reactions and for keeping redox sites at highly different potential simultaneously within a living organism. Thus, direct → *electron transfer* between redox enzymes and electrode surfaces can be often only observed for those enzymes which have their active site close to the protein surface. In order to access the active site of those enzymes which do not show any direct electrochemical communication with electrodes these enzymes can be modified (“wired”) with artificial redox relay such as ferrocene derivatives, Os-complexes, methylviologen derivatives, or PQQ derivatives. Often a partial denaturation of the enzyme prior to the covalent binding of the redox relays is required implying the necessity of a functional refolding after enzyme modification. The covalently attached redox relays shorten the overall electron-transfer distance and hence increase the probability for the electron transfer by means of electron hopping between the redox relays. This is similar to the electron-transfer mechanism in multi-cofactor enzymes.

Refs.: [i] Bartlett PN, Whitaker RG, Green MJ, Frew JE (1987) *J Chem Soc Chem Commun* 1603; [ii] Degani Y, Heller A (1987) *J Phys Chem* 91:1285; [iii] Bartlett PN, Whitaker RG (1988) *Biosensors* 3:359; [iv] Bartlett PN, Bradford VQ, Whitaker RG (1991) *Talanta* 38:57; [v] Schuhmann W, Ohara TJ, Schmidt HL, Heller A (1991) *J Am Chem Soc* 113:1394;

[vi] Habermüller K, Reiter S, Buck H, Meier T, Staepels J, Schuhmann W (2003) *Microchim Acta* 143:113

WSchu

Redox polymer — Redox polymers contain electrostatically and spatially localized redox sites, which can be oxidized or reduced. The redox polymers can be divided into subclasses: 1) polymers that contain covalently attached redox sites, either built in the chain or as a pendant group. The redox centers may be organic molecules (e.g., tetrathiafulvalene, tetracyanoquinodimethane), organometallic molecules (e.g., → *ferrocene*), or coordinatively attached redox couples (e.g., polymerized metal bipyridine(bpy) complexes); 2) ion-exchange polymeric systems, where the redox-active ions are held by electrostatic binding (e.g., $\text{Fe}(\text{CN})_6^{3-/4-}$ in protonated poly(vinylpyridine) or $\text{Ru}(\text{bpy})_3^{3+/2+}$ in → *Nafion* [i]).

The polymer layers swell in aqueous electrolyte under formation of a redox hydrogel allowing for fast diffusion of ions within the polymer matrix. → *Electron transfer* between neighboring redox sites is possible due to the flexibility of the polymer backbone allowing for colliding of two redox sites undergoing electron self-exchange processes. This process is called → *electron hopping* and leads finally to an electron transfer through the polymer in accordance with a potential applied to the underlying electrode. The electron-transfer kinetic in redox polymers is dependent on the loading of the polymer with redox relays, the flexibility and motion of the polymer film, counter ion movement concomitant with the electron-transfer reaction.

See also → *conducting polymers*, and → *electrochemically stimulated conformational relaxation (ESCR) model*. Refs.: [i] Lyons MEG, Fay HG, Vos JG, Kelly AJ (1988) *J Electroanal Chem* 250:207; [ii] Geraty SM, Vos JG (1987) *J Chem Soc Dalton Trans* 3073; [iii] Gregg BA, Heller A (1990) *Anal Chem* 62:258; [iv] Forster RJ, Vos JG (1990) *Macromol* 23:4372; [v] Forster RJ, Vos JG, Lyons MEG (1991) *J Chem Soc Faraday Trans* 87:3761; [vi] Aoki A, Heller A (1993) *J Phys Chem* 97:11014

WSchu

Redox potential → *potential*, and → *oxidation–reduction potential*

Redox reactions — are chemical reactions in which the reactants exchange electrons between each other. As a consequence, the oxidation states of the elements prior to and following the redox reaction are altered. The processes of gaining and expelling electrons are termed → *reduction* and → *oxidation*, respectively. Each redox

reaction comprises both reduction and oxidation that occur simultaneously. The reactants undergoing reduction are termed oxidant, whereas those being oxidized are termed reductant. The redox reaction can be formally split into, at least, two half-reactions representing separately the oxidation and reduction. The oxidized and reduced forms of a single participant in a half-reaction comprise a → *redox couple*. Each half-reaction is attributed with a → *standard (redox) potential*, measured versus the → *standard hydrogen electrode* as a reference system. Note that “pure” → *half-cell reactions* have no meaning because they are experimentally inaccessible. → *standard potentials* always refer to the reduction of an oxidized species coupled to the oxidation of hydrogen to H_3O^+ . Half-cell reactions should also not be taken as the reactions defining → *electron affinity* and → *ionization energies* in vacuum, because these data refer to species existing in vacuum stripped off of their coordination sphere and → *solvation sheath*.

VM

Redox state — Redox state means the → *oxidation* state of a compound or element. In → *electrochemistry* this term is also used to characterize the ratio of the oxidized to the reduced form of one redox species when both forms are present in a solution or solid compound. Frequently it is necessary to determine this ratio using electrochemical methods. For a fast and → *reversible electrode reaction* $\text{Ox} + n e^- \rightleftharpoons \text{Red}$ the following techniques can be applied:

- *potentiometry*: an → *open-circuit potential (OCP)* of a → *redox electrode* $\text{M}|\text{Ox, Red}$ is defined by the → *Nernst equation*: $E_{\text{OCP}} = E_c^{\ominus'} + \frac{RT}{nF} \ln \frac{c_{\text{ox}}^*}{c_{\text{red}}^*}$, where c_{ox}^* and c_{red}^* are bulk concentrations of the oxidized and reduced forms of the redox couple, respectively, $E_c^{\ominus'}$ is a → *formal potential* in the chosen → *electrolyte* and M is an inert electronic conductor. If the formal potential is known, the ratio of c_{ox}^* and c_{red}^* can be calculated by the equation: $\frac{c_{\text{ox}}^*}{c_{\text{red}}^*} = \exp \left[\frac{nF}{RT} (E_{\text{OCP}} - E_c^{\ominus'}) \right]$.
- DC → *polarography*: the ratio of c_{ox}^* and c_{red}^* can be approximately estimated from the ratio of → *limiting currents* of the DC polarogram of this system: $I = \frac{nFS \sqrt{\frac{D_{\text{ox}}}{\pi t}} (c_{\text{red}}^* \exp(\varphi) - c_{\text{ox}}^*)}{1 + \sqrt{\frac{D_{\text{ox}}}{D_{\text{red}}}} \exp(\varphi)}$, where D_{ox} and D_{red} are → *diffusion coefficients*, t is a drop lifetime, S is an electrode surface area, and $\varphi = (nF/RT) (E - E_c^{\ominus'})$. If $E \gg E_{\text{OCP}}$ the limiting current of oxidation is: $I_{\text{lim,ox}} = nFS c_{\text{red}}^* \sqrt{D_{\text{red}}/\pi t}$

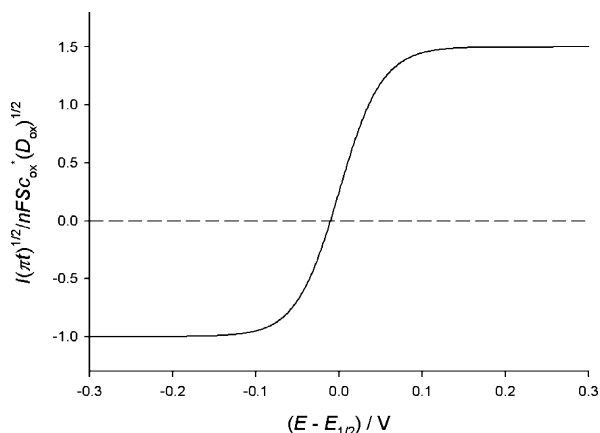

Redox state — Figure. DC polarographic wave for $c_{\text{red}}^*/c_{\text{ox}}^* = 1.5$

(*). If $E \ll E_{\text{OCP}}$ the limiting current of reduction is: $I_{\text{lim,red}} = -nFS c_{\text{ox}}^* \sqrt{D_{\text{ox}}/\pi t}$ (**). Hence: $I_{\text{lim,ox}}/I_{\text{lim,red}} = -(c_{\text{red}}^*/c_{\text{ox}}^*) \sqrt{D_{\text{red}}/D_{\text{ox}}}$ (***) (see the Figure) [i].

- c) \rightarrow *chronoamperometry*: starting from OCP, the electrode is charged to the constant potentials $E \gg E_{\text{OCP}}$ and $E \ll E_{\text{OCP}}$. The currents measured after a certain time t are defined by equations (*) and (**), respectively. The ratio $c_{\text{red}}^*/c_{\text{ox}}^*$ is estimated using equation (***) [ii].
- d) \rightarrow *cyclic voltammetry*: starting from OCP the potential is cycled in such a manner that $E_{\text{rv,a}} - E_{\text{p,a}} = E_{\text{p,c}} - E_{\text{rv,c}}$, where $E_{\text{p,a}}$ and $E_{\text{p,c}}$ are anodic and cathodic peak potentials, respectively, and $E_{\text{rv,a}}$ and $E_{\text{rv,c}}$ are anodic and cathodic reverse potentials, respectively. The difference of absolute values of the currents $I_{\text{rv,a}}$ and $I_{\text{rv,c}}$, corresponding to the potentials $E_{\text{rv,a}}$ and $E_{\text{rv,c}}$, respectively, is a linear function of the mole fraction of the bulk concentrations $\frac{c_{\text{red}}^*}{c_{\text{red}}^* + c_{\text{ox}}^*}$ [iii]. If the question is only to decide whether the oxidized or reduced form is present in the bulk of the solution, the “switching on currents” at the positive and negative limits of the cyclic voltammogram (CV) give that information. When the CV is started at the positive limit and the compound is in the reduced state, a large “switching on current” will be observed. If the compound is in the oxidized state that current will be negligible. For starting the CV at the negative limit the observation will be opposite, i.e., high current for oxidized form and negligible current for reduced form [ii].

Refs.: [i] Heyrovsky J, Kuta J (1966) *Principles of polarography*. Academic Press, New York; [ii] Marken F, Neudeck A, Bond AM (2002) *Cyclic voltammetry*. In: Scholz F (ed) *Electroanalytical methods*. Springer, Berlin; [iii] Scholz F, Hermes M (1999) *Electrochem Commun* 1:345

ŠKL

Redox titration — A \rightarrow titration method in which electrons are transferred between the \rightarrow titrant and the \rightarrow analyte. Usually, the \rightarrow end point of oxidation/reduction reactions is measured by chemical or potentiometric methods. The chemical method involves an \rightarrow indicator that usually has a change in color at the end point, while the other method is a \rightarrow potentiometric titration [i].

Ref.: [i] Harris D (2002) *Quantitative chemical analysis*. WH Freeman, New York

FG

Reductant — A substance, also called reducing agent, that reduces another substance by donating electrons to this reagent to establish a lower energetic state. The reductant itself is oxidized during this reaction.

Hence, reductants are electron donors in \rightarrow redox reactions. A measure of the reduction power is the \rightarrow redox potential.

Important reductants are, for instance, Sn^{2+} , Cr^{2+} , hydrazine, ascorbic acid, etc., and most importantly in electrochemistry, an \rightarrow electrode that serves as an electron source.

BM

Reduction — The opposite of \rightarrow oxidation. In a narrow sense, reduction means the departing of oxygen from a substance.

In a general sense, reduction is a reaction in which a substance gains electrons from another reagent called \rightarrow reductant which itself is oxidized. The oxidation number of the substance being reduced decreases. Reduction always occurs simultaneously with oxidation. Reduction reactions play an important role in metallurgy, e.g., smelting ores, and most importantly in electrochemistry, where they proceed at \rightarrow cathodes.

BM

Reduction potential \rightarrow potential, subentry \rightarrow reduction potential

Reference electrode — The reference electrode [i–iii] allows the control of the potential of a \rightarrow working electrode or the measurement of the potential of an \rightarrow indicator electrode relative to that reference electrode. The rate, the product, and the product distribution of \rightarrow electrode

reactions depend on the \rightarrow electrode potential. Knowledge of the electrode potential is of utmost importance in order to design any electrochemical device or to carry out any meaningful measurement. When current flows through an \rightarrow electrochemical cell the potential of one of the electrodes should remain practically constant – it is the reference electrode – in order to have a well-defined value for the electrode potential of the electrode under investigation or to control its potential. An \rightarrow ideally nonpolarizable electrode or an electrode the behavior of which is close to it may serve as a reference electrode. The choice and the construction of the reference electrode depend on the experimental or technical conditions, among others on the \rightarrow current applied, the nature, and composition of the \rightarrow electrolyte (e.g., aqueous solution, nonaqueous solution, melts, \rightarrow solid electrolyte), and temperature.

Both the \rightarrow standard hydrogen electrode (SHE), which is the primary standard in electrochemistry [iv, v] and the relative hydrogen electrode (RHE) are widely used in aqueous acidic solutions. In RHE the nature and concentration of acid is the same in the reference and the main compartments. In general, it is advantageous to use the same solution in both compartments to decrease the \rightarrow junction potential. By the help of RHE the \rightarrow activity effect can also be eliminated when the \rightarrow pH dependence of a \rightarrow redox reaction is to be determined, since the H^+ ion activity influences both the redox reactions under study and the redox reaction occurring in the reference system ($1/2H_2 \rightarrow H^+ + e^-$) in the same way.

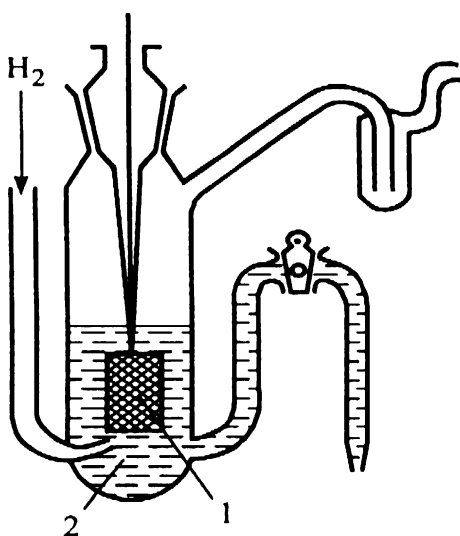

Reference electrode — Figure 1. Hydrogen electrode, (1) platinized platinum, (2) acid solution saturated with H_2

\rightarrow Electrodes of the second kind such as $Ag|AgCl$ and the calomel electrode ($Hg|Hg_2Cl_2$) are frequently used as reference electrodes in aqueous solutions. In solutions containing sulfuric acid $Hg|Hg_2SO_4$, while in alkaline media $Hg|HgO$ are also applied. The potential of these electrodes depends on the concentration (activity) of the electrolyte used. In the commercial calomel electrodes usually KCl solutions are applied. However, if the supporting electrolyte in the cell is $HClO_4$ or any perchlorate salt it is advisable to use NaCl since $KClO_4$ is a sparingly soluble salt and may fill up the diaphragm (frit) and insulate the reference electrode.

The precipitation is especially enhanced because mostly a saturated KCl solution is used to decrease the \rightarrow junction potential. It should be noted that by changing KCl for NaCl the potential of the saturated calomel electrode (SCE) will be varied which is due to the different solubilities. In the case of electrodes of the second kind the effect of temperature on the solubility has to be considered, too. It is of importance to prevent to exchange electrolytes between the main and the reference compartments. For instance, a leakage of chloride ions, which is strongly adsorbed at platinum, may influ-

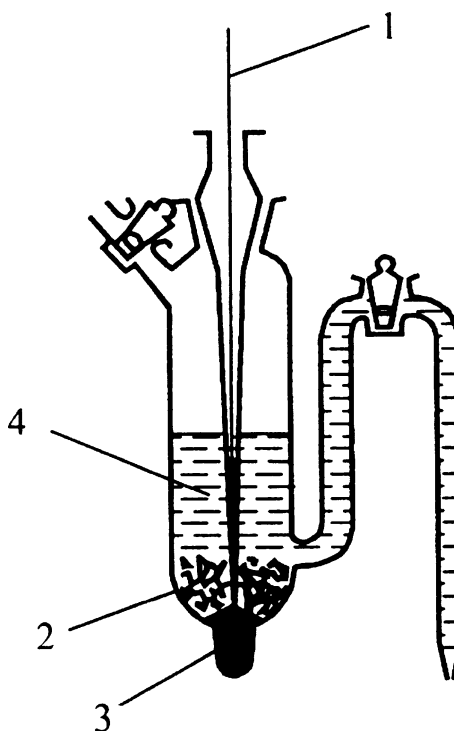

Reference electrode — Figure 2. Calomel reference electrode: (1) platinum wire, (2) paste of mercury and Hg_2Cl_2 , (3) liquid mercury, (4) KCl or NaCl solution

ence the electrode reaction substantially, or enhances the \rightarrow *pitting corrosion* of metals. After a longer period of use it is advisable to refill the reference electrode with a fresh solution.

In the two-electrode configuration one of the electrodes which serves as the \rightarrow *counter electrode* may also play the role of the reference electrode. The same metal might be used if the surface area of the reference electrode (A_{ref}) is much higher than that of the working electrode (A_{work}), since the electrode potential is varied by the \rightarrow *current density* (see \rightarrow *Butler-Volmer equation*), therefore, if $A_{\text{ref}} \gg A_{\text{work}} j_{\text{ref}} \ll j_{\text{work}}$, consequently the change of the potential of the reference will be small. A typical example is the large mercury pool counter/reference electrode used in classical \rightarrow *polarography*, however, the small area platinum working electrode and large area \rightarrow *platinized platinum electrode* arrangement is also often used. In work with \rightarrow *microelectrodes* or \rightarrow *ultramicroelectrodes* the \rightarrow *two-electrode system* is widely applied.

The position of the reference electrode and the separation of the compartments of the reference and working electrodes are crucial to obtain reliable data for the electrode potential of the indicator electrode or to control the potential of the working electrode. In order to de-

crease the effect of the ohmic potential drop it is a general rule that the working and the reference electrodes can be positioned as near as possible. For this purpose the \rightarrow *Luggin capillary* is also recommended.

In order to prevent the mixing of the electrolytes of the reference electrode and the working electrode a \rightarrow *diaphragm* is used. The diaphragm is most often some kind of porous material (sintered glass, ceramics, organic polymer membrane or gel) or a wetted stopper without grease (the thin electrolyte film is enough to maintain an appropriate electrolytic conductivity). One must be careful in respect of the choice of the material since glass diaphragms will easily be dissolved in strongly alkaline solutions, while organic solvent may attack organic membranes. The diaphragm has to be cleaned from time to time.

In order to prevent the contamination of the reference electrode or the mixing of the electrolytes an arrangement with double salt bridge is also applied.

In \rightarrow *glass electrodes* and other \rightarrow *ion-selective electrodes* two reference electrodes are used, the one which is placed inside the bulb-shaped glass or other membrane is called internal or inner reference electrode. It is usually an Ag|AgCl|HCl(aq) system.

In nonaqueous solutions it is necessary to use a standard reaction other than the oxidation of molecular hydrogen. There is no general standard reaction in non-aqueous solvents at this time [iv]. \rightarrow *Ferrocene/ferricenium ion* and bis(biphenyl)chromium (I)/bis(biphenyl)chromium (0) are recommended as reference redox systems [vi, vii]. Among the electrodes of the first kind silver-silver ion electrode is a widely used reference electrode in nonaqueous solvents such as acetonitrile. The electrode consists of a silver wire immersed in a solution of AgClO_4 or AgNO_3 . The reference compartment is connected to the main compartment through a salt bridge containing NaClO_4 or tetraalkylammonium perchlorate solutions. This electrode cannot be used in dimethylformamide (DMF) since Ag^+ ions react with DMF. Zinc amalgam, $\text{Zn(Hg)|Zn(ClO}_4)_2$, or ZnCl_2 has been employed in dimethyl sulfoxide (DMSO) and ammonia. Na(Hg)|NaClO_4 and Li(Hg)|LiCl have been used in DMF and DMSO, respectively. Among the electrodes of the second kind silver-silver chloride is often used in DMF, nitromethane, acetic acid, and sometimes in acetonitrile; however, due to the complex formation it is not recommended, and because of the same reason it cannot be used in liquid ammonia. Calomel electrode is also used but care must be taken to avoid contamination of the organic solvent with water when calomel

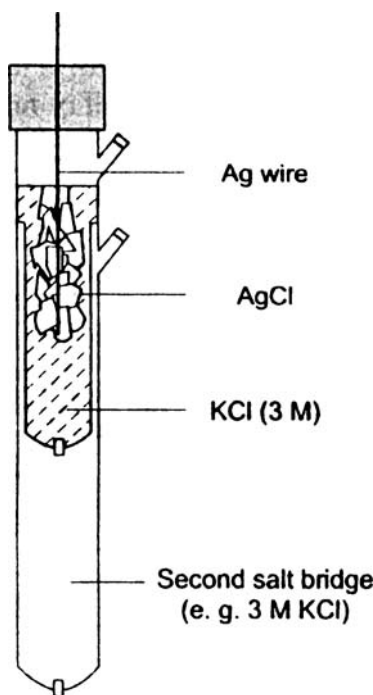

Reference electrode — Figure 3. Silver|silver-chloride reference electrode with a second salt bridge

or Ag|AgCl electrodes are applied. Copper fluoride electrode can be used in HF, and Tl(Hg)|TlCl|LiCl, Cd(Hg)|CdCl₂, NaCl, Pb(Hg)|PbCl₂|NaCl electrodes in DMSO and DMF. Porous Vycor® glass is well suited to be used as a diaphragm between aqueous and nonaqueous solutions.

In many cases platinum or silver wires serve as quasireference electrodes, however, they have to be calibrated by a reference redox systems. [The term pseudoreference (literally 'false' reference) electrode is also used in the literature, however, the term quasireference electrode is preferred].

When the electrolysis is carried out in molten salts at high temperature special, chemically highly resistant reference electrodes should be used. In most cases no reference electrodes or quasireference electrodes, such as a piece of metal (Mo, Al–Li alloy etc.), are used. However, in many two-electrode systems one of the electrodes consists of a metal and its fused salt, e.g., Ag|AgCl, Mg|MgCl₂, Pb|PbCl₂, Tl|TlCl, Zn|ZnCl₂ or oxide, e.g., Al|Al₂O₃ which enables comparison of the electrode potentials.

See also → *potentiostat*, → *three-electrode system*.

Refs.: [i] Kahlert H (2002) *Reference electrodes*. In: Scholz F (ed) *Electroanalytical methods*. Springer, Berlin, pp 261–277; [ii] Ives DJG, Janz GJ (1961) *Reference electrodes*. Academic Press, New York; [iii] Bard AJ, Faulkner LR (2001) *Electrochemical methods*, 2nd edn. Wiley, New York, pp 24–28; [iv] Parsons G (1974) *Pure Appl Chem* 37:503; [v] Inzelt G (2006) *Standard potentials*. In: Bard AJ, Stratman M, Scholz F, Pickett CJ (eds) *Inorganic electrochemistry*. Encyclopedia of electrochemistry, vol. 7A. Wiley-VCH, Weinheim, p 1; [vi] Lund H (1983) *Reference electrodes*. In: Baizer MM, Lund H (eds) *Organic electrochemistry*. Marcel Dekker, New York, chap 5 V, pp 187–191; [vii] Gritzner G, Kuta J (1984) *Pure Appl Chem* 56:461; [viii] Dobos D (1975) *Electrochemical data*. Akadémiai Kiadó, Budapest

GI

Reference electrode field effect transistor → REFET

REFET (Reference electrode field effect transistor) — A solid-state → *semiconductor* device operated as a reference electrode. Typically a pH-sensitive → *CHEMFET* is filled with pH-buffered gel on the pH-sensitive membrane attached to the gate of the FET keeping the operating conditions of the FET and thus the associated potential constant.

Ref.: [i] Errachid A, Bausells J, Jaffrezic-Renault N (1999) *Sens Actuators* B60:43

RH

Reflecting galvanometer → mirror galvanometer

Reflection mode → spectroelectrochemistry

Reflective boundary/interface — This term originates from the optical, high-vacuum electron- or ion-beam spectroscopies to indicate that the interface between two media reflects the light or particle beam falling on the interface from one of the media, i.e., sends it back to the same medium, in a specular (like a mirror) or diffuse (scattering) way. The same term is also used in diffusion (or diffusion-migration or convective diffusion (→ *diffusion*)) problems for species inside a solution or a solid phase. In this context it is a synonym of → *blocking boundary/interface*.

Ref.: [i] Retter U, Lohse H (2005) *Electrochemical impedance spectroscopy*. In: Scholz F (ed) *Electroanalytical methods*. Springer, Berlin, chap II.5

MAV

Refraction — A change in direction of a propagating wave of light or sound when it passes from one medium to another with a different → *refractive index*, or through a medium with an inhomogeneous → *refractive index* in which there is a change in the velocity of the propagating wave. The term is also used to indicate the amount by which a propagating wave is bent [i]. See also → *mirage effect*.

Ref.: [i] Rosolen JM, Decker F, Fracastoro-Decker M, Gorenstein A, Torresi RM, Cordoba Torresi SI (1993) *J Electroanal Chem* 354:273

FG

Refractive index — A fundamental physical property of materials through which light can travel. It is usually indicated by the symbol n , and it is defined as $n = c/c_0$, where c_0 is the speed of light in vacuum and c corresponds to the speed at which the crests of electromagnetic radiation corresponding to a specific frequency propagate in a material [i, ii]. A more rigorous definition for the refractive index of a dense and isotropic material composed of a unique kind of particles (atoms or molecules) is given by the equation: $n = \sqrt{1 + \frac{N\alpha(\omega)}{1 - N\alpha(\omega)}}$, N is the number per unit of volume of particles in the material, and $\alpha(\omega)$ is the → *polarizability* of these particles. The precise evaluation of $\alpha(\omega)$ is a difficult problem of quantum mechanics. Nevertheless, it can be approximated as: $\alpha(\omega) = \frac{e^2}{m_e \epsilon_0} \sum_k \left(\frac{f_k}{-\omega^2 + i\gamma_k \omega + \omega_{0k}^2} \right)$, where e is the charge on the electron, ϵ_0 is the → *permittivity* of vacuum, m_e is the mass of the → *electron*, ω is the angular frequency of the radiation, ω_{0k} is the k -th resonant frequency of an electron of this material, $i = \sqrt{-1}$, f_k and γ_k are the strength factor and the damping coefficient for

each mode of oscillation k . Consequently, the index of refraction of a material is not only the number, but also a function with real and imaginary parts that depend on the frequency of the electromagnetic radiation. For that reason, values of n are commonly tabulated at various well-defined spectral emission lines such as the center of the yellow sodium double emission at 589.29 nm (Fraunhofer "D" line). Thus, the index of refraction of a material corresponding to a given frequency can be expressed as a complex number: $\tilde{n} = n - in'$; in which n is the factor that indicates the speed at which the crests of an electromagnetic wave travel in a material with regard to the speed of that wave in vacuum. Usually, this factor n is the value of the refractive index that is found in tables. The imaginary part, however, represents the attenuation of the wave due to dissipation of the oscillators of the material. In fact, n' is sometimes referred to as the absorption index and it describes the magnitude in which the amplitude of the electromagnetic wave is decreased when it travels through the material [ii].

Refs.: [i] Mills I, Cvitas T, Homann K, Kallay N, Kuchitsu K (eds) (1993) *IUPAC quantities, units and symbols in physical chemistry*. Blackwell Science, Oxford; [ii] Feynman RP, Leighton RB, Sands M (1989) *The Feynman Lectures on physics*, vols. I, II. Addison-Wesley, Massachusetts

FG

Reilley, Charles Norwood



(Mar. 2, 1925, Charlotte, NC., USA – Dec. 31, 1981, Chapel Hill, NC, USA) Charles Reilley received his Ph.D. in 1952 from Princeton University, studying under Professor N.H. Furman. He then joined the faculty at the University of North Carolina, Chapel Hill, and rose to a Distinguished Professorship (Kenan Professor) by 1963, having become recognized as one of the first modern analytical chemists of the mid-20th century. Reilley has great breadth in his research, and made important contributions to analytical aspects of electroanalysis, optical spectroscopy, magnetic resonance spectroscopy,

chemical separations, data analysis, instrumentation, and surface analysis, through research that was fundamentally based yet cognizant of significant applications in analytical measurements. He devised many instrumental methods for detection of chemical reactions as they reached stoichiometric completion, using polarized electrodes, coulometry, high frequency impedance, optical absorbance, and nuclear magnetic resonance. He introduced a substantial range of metal chelate chemistry for the same purpose, including methods for determining their equilibrium constants [i]. He contributed to early understanding of chronopotentiometry and thin layer electrochemistry, and with Okun and Mancy [ii] invented a membrane electrode that was commercialized for determination of dissolved oxygen in natural waters. He showed in 1964 how to use NMR to determine microscopic acidity base constants of poly-protic acids [iii], notably those involved in metal chelation, and with T. Isenhour introduced in 1969 a new field of chemical information analysis now known as chemometrics [iv]. In 1972 he introduced concepts of using low temperatures as a tactic in studying electrochemical reactions with coupled chemical processes [v].

Among the many recognitions of Reilley's research contributions were the ACS Award in Analytical Chemistry (1965), the Herty Medal (1968), the Stone Award (1971), and by election to the National Academy of Sciences (US) in 1977. The Society of Electroanalytical Chemistry was formed following his death, to sponsor an award in his name, the Charles N. Reilley Award, which has been presented annually at the Pittcon Conference since 1984. A more extensive biography of Charles Reilley has recently been published [vi].

Refs.: [i] Schmid RW, Reilley CN (1956) *J Amer Chem Soc* 78:2910; [ii] Mancy KH, Okun DA, Reilley CN (1962) *J Electroanal Chem* 4:65; [iii] Sudmeier JL, Reilley CN (1964) *Anal Chem* 36:1698; [iv] Jurs PC, Kowalski BR, Isenhour TL, Reilley CN (1969) *Anal Chem* 41:690; [v] Van Duyne RP, Reilley CN (1972) *Anal Chem* 44:142, 153, 158; [vi] (2006) *Bibliographical Memoirs*, Vol. 88, National Academy of Sciences, Washington, DC (<http://fermat.nap.edu/html/biomems/creilley.pdf>)

RWM

Relaxation → *relaxation effect*, and → *relaxation techniques*

Relaxation effect — Ions inside an → *electrolyte* solution exposed to an external electric field in, e.g., a conductivity measurement are attracted to one of the two electrodes depending on their individual polarity. Accordingly the central ion will be attracted to one electrode whereas the ions of the ionic cloud will be at-

tracted towards the opposite electrode. With increasing electrolyte concentration the average distance between the ions becomes smaller, thus this effect counteracting the ionic movement in the electric field will increase. See → *Debye–Falkenhagen effect*.

Ref.: [i] Rieger PH (1994) *Electrochemistry*. Chapman-Hall, New York, p 124

RH

Relaxation techniques — When a chemical system at → *equilibrium* is disturbed in some way so as to cause the equilibrium to shift, the relaxation of the system, i.e., the changes with time, to the new state of equilibrium can be followed by different techniques (e.g., by the spectroscopic determination of the nature and concentration of the species). Relaxation techniques have been developed to follow chemical changes which occur very rapidly.

For decades the electrochemical techniques, i.e., potential, current, or charge step methods such as → *chronoamperometry*, → *chronocoulometry*, → *chronopotentiometry*, → *coulostatic techniques* were considered as fast techniques, and only with other pulse techniques such as temperature jump (T-jump) introduced by Eigen [i] or flash-photolysis method invented by Norrish and Porter [ii], much shorter time ranges became accessible. (For these achievements Eigen, Norrish, and Porter shared the 1964 Nobel Prize.) The advanced versions of flash-photolysis allow to study fast homogeneous reactions, even in the picosecond and femtosecond ranges [iii] (Zewail, A.H., Nobel Prize in Chemistry, 1999). Several other techniques have been elaborated for the study of rapid reactions, e.g., flow techniques (stopped-flow method), ultrasonic methods, pressure jump, pH-jump, NMR methods.

The time range of the electrochemical measurements has been decreased considerably by using more powerful → *potentiostats*, circuitry, → *microelectrodes*, etc.: by pulse techniques, fast → *cyclic voltammetry*, → *scanning electrochemical microscopy* the 10^{-6} – 10^{-10} s range has become available [iv, v]. The electrochemical techniques have been combined with spectroscopic ones (see → *spectroelectrochemistry*) which have successfully been applied for relaxation studies [vi]. For the study of the rate of heterogeneous → *electron transfer* processes the ILIT (Indirect Laser Induced Temperature) method has been developed [vi]. It applies a small temperature perturbation, e.g., of 5 K, and the change of the open-circuit potential is followed during the relaxation period. By this method a response function of the order of 1–10 ns has been achieved.

Refs.: [i] Eigen M (1954) *Discuss Faraday Soc* 17:194; [ii] Norrish RGW, Porter G (1949) *Nature* 164:658; (1952) *Proc R Soc A* 210:439; [iii] Dian EW-G, Herek JL, Kim ZH, Zewail AH (1999) *Science* 279:847; [iv] Bard AJ (1992) *Pure Appl Chem* 64:185; [v] Bard AJ, Fan F-R, Mirkin MV (1994) *Scanning electrochemical microscopy*. In: Bard AJ (ed) *Electroanalytical chemistry*, vol. 18. Marcel Dekker, New York; [vi] Neudeck A, Marken F, Compton RG (2002) *UV/Vis/NIR spectroelectrochemistry*. In: Scholz F (ed) *Electroanalytical methods*. Springer, Berlin, pp 167–189; [vii] Feldberg SW, Newton MD, Smalley JF (2004) *The indirect laser-induced temperature jump method for characterizing fast interfacial electron transfer: concept, application, and results*. In: Bard AJ, Rubinstein I (eds) *Electroanalytical chemistry*, vol. 22. Marcel Dekker, New York, pp 101–180

GI

Reserve battery — A cell (→ *electrochemical cell*) or a → *battery* in which one or more of its components (usually the → *electrolyte solution*) is either separated or rendered inactive by chemical or physical means, in order to impart long shelf life. In most cases the electrolyte solution is maintained in a separate container, and injected to the cell upon activation. Among the most common types of reserve batteries are the water-activated, gas-activated, and heat-activated batteries. Water-activated batteries, like the magnesium water-activated batteries, carry dry salt in the separator, and water introduction to the cell dissolves the salts and sets the cell active. Gas-activated batteries use either electroactive gas or, like the ammonia reserve battery, in which the liquid compressed gas furnishes the solvent for the battery's electrolyte. In thermal batteries, a specific type of reserve battery, during storage the electrolyte is in the solid state. Upon demand the cell is activated by heating the battery to the melting-point of the salt or solution. This way self discharge, → *corrosion*, and parasitic reactions during storage are negligible, and very long shelf lives can be obtained, even when the active materials used in the cell are extremely energetic (and, thus, relatively less stable). Reserve batteries are nonrechargeable (primary). The most common reserve battery systems are: water-activated magnesium (including seawater-activated), zinc–silver oxide reserve battery, and some specialized spin-dependent and thermal batteries. The last two types of batteries are used for very specialized purposes, like marine and military applications.

Refs.: [i] Dell RM, Rand DAJ (2001) *Understanding batteries*. The royal society of chemistry, Cambridge, pp 87–97; [ii] Linden D (1994) *Reserve batteries*. In: Linden D (ed) *Handbook of batteries*, 2nd edn. McGraw-Hill, New York, part three, chaps. 16–22; [iii] Crompton TR (2000) *Battery reference book*, 3rd edn. Newnes, Oxford, p 56/12

YG

Residual — A value resulting from the difference between a measured datum of the dependent variable ‘ y_i ’ and a value predicted by a suitable fitting function ‘ $f(x_i)$ ’ [i].

Ref.: [i] Ryan TP (1997) *Modern regression methods*. Wiley Interscience, New York

Residual current — Small \rightarrow current observed in the \rightarrow potential window even in the absence of the substance whose behavior is being investigated (i.e., in a blank solution). The residual current consists of two components: a nonfaradaic \rightarrow charging current and a \rightarrow faradaic current due to the redox reactions of impurities including oxygen and to the partial electrolysis of solvent or supporting electrolyte. See also \rightarrow background current.

FG

Residual standard deviation — (σ_r) A measure of the closeness between a set of experimental data corresponding to the dependent variable ‘ Y ’ and a respective array of values calculated according to a given mathematical model ‘ $F(x)$ ’. Consequently, it is assumed that the dependent variable contains all the error of measurements and there is no error in the values of the independent variable ‘ x ’. A very low standard deviation of a fit does not mean that the assigned mathematical model is reasonable since the parameters resulting of a fit may have values that make no sense, or the proposed model can be a bad descriptor of the experiment. If each data point provides equally precise information about the total process variation, the value of σ_r is defined as the positive square root of the sum of the squares of the \rightarrow residuals, divided by the number of experimental data points ‘ n ’, minus the number of fitted parameters ‘ p ’ [i, ii]. It can be calculated as:

$$\sigma_r = \sqrt{\frac{\sum_{i=1}^n (y_i - f(x_i))^2}{n - p}}$$

Refs.: [i] Ryan TP (1997) *Modern regression methods*. Wiley Interscience, New York; [ii] Seber GAF, Wild CF (1989) *Nonlinear regression*. Wiley, New York

FG

Resistance — Electrical resistance is the property of a material to resist or oppose the flow of an electrical \rightarrow current. The SI unit of resistance is the ohm (given the Greek symbol Ω). The reciprocal of resistance is \rightarrow conductance, measured in siemens (S). The resistance of a material determines the magnitude of \rightarrow current that flows for a given \rightarrow voltage applied across the material, as given by \rightarrow Ohm’s law, $\Delta E = I \cdot R$, where ΔE is the potential difference across the material measured in \rightarrow volts,

I is the current passing through the material measured in \rightarrow amperes, and R is the resistance of the object in ohms. When the resistance of a material depends on voltage and current, the differential resistance is used, defined as the slope of the ΔE – I graph at a particular point, thus

$$R = \frac{d\Delta E}{dI}$$

Resistance and differential resistance are equivalent only for an ohmic component such as an ideal resistor. Power in the form of heat is dissipated when current flows through a resistance, given by $P = I^2 \cdot R$.

If the current density is totally uniform in the material, then the resistance R of a material of regular cross section can be computed as

TO

$$R = \frac{L \cdot \rho}{A}$$

where L is the length of the material in meters, A is the cross-sectional area in square meters, and ρ is the (temperature-dependent) electrical resistivity of the material in ohm \cdot meter [$\Omega \cdot \text{m}$]. Thus, resistivity is an intrinsic measure of a material’s ability to oppose current flow, independent of its geometry. In most practical situations the current density is not totally uniform. Additionally, high frequency alternating currents can diminish the effective cross section of a conductor. The resistivity (and thus the resistance) is temperature dependent. Resistivity ranges from $10^{-8} \Omega \text{ m}$ for metals such as silver or copper to ca. $10^{16} \Omega \text{ m}$ for insulators such as fused quartz.

DT

Ohmic resistance — For a wide variety of materials and conditions, the electrical resistance does not depend on the amount of current flowing or the amount of applied voltage. In such cases, a plot of voltage applied (measured) across the material versus the measured (applied) current through the material will be linear, the slope of the plot being the ohmic resistance, R_Ω . The material obeys ohm’s law and such materials are described as ohmic. See \rightarrow ohmic resistance behavior.

DT

Solution resistance — Current flow through solutions is due to movement of ionic species, the resistance depending on the types of ions and their concentrations, the temperature, and the geometry of the area in which current is carried. The resistivity of an \rightarrow electrolyte is given by

$$\rho = \frac{1}{F \sum_i |z_i| u_i c_i}$$

where z_i , u_i , and c_i are the charge, \rightarrow mobility (temperature-dependent), and concentration, respectively, of ion i . Unfortunately, most electrochemical cells do not have uniform current distribution through a definite electrolyte area and, thus, calculation of resistance from resistivity is difficult if not impossible. However, solution resistance (or its reciprocal, the conductance) can be measured by a number of approaches [i]. Furthermore, by calibrating a cell with an electrolyte of known resistivity (i.e., determining the “cell constant”), the resistivity of an unknown electrolyte can be determined.

Ref.: [i] Holler FJ, Enke CG (1996) *Conductivity and conductometry*. In: Kissinger PT, Heineman WR (eds) *Laboratory techniques in electroanalytical chemistry*, 2nd edn. Marcel Dekker, New York, chap 8

DT

Uncompensated resistance — A modern 3-electrode potentiostat compensates for the solution resistance between the counter and \rightarrow reference electrodes, but not for the solution resistance between the reference electrode and the \rightarrow working electrode. Such resistance is referred to as the uncompensated resistance (R_u). The resistance of the working electrode itself also contributes to the uncompensated resistance (but is almost always negligible with metal electrodes). The voltage drop across R_u due to a current flow is IR_u and results in a potential control error. Factors that influence R_u (and thus IR_u) include \rightarrow conductivity of the electrolyte, shape and size of the cell, the location of the reference electrode, the shape of the working electrode, and the size and position of the counter electrode [i, ii]. R_u can be lowered by addition of \rightarrow supporting electrolyte and/or by positioning the reference electrode very close to the working electrode by means of a \rightarrow Luggin probe, so in many cases IR_u can be rendered negligible. In cases where it is not negligible, IR_u can be compensated for electronically by using positive feedback [iii] or by interruption and automatic compensation method or the data may be correctable after completion of the experiment [iv]. See \rightarrow uncompensated IR drop.

Refs.: [i] Myland JC, Oldham KB (2000) *Anal Chem* 72:3972; [ii] Oldham KB, Stevens NPC (2000) *Anal Chem* 72:541; [iii] Roe DK (1996) *Overcoming solution resistance with stability and grace in potentiostatic circuits*. In: Kissinger PT, Heineman WR (eds) *Laboratory techniques in electroanalytical chemistry*, 2nd edn. Marcel Dekker, New York, chap 7; [iv] Oldham KB, Myland JC (1994) *Fundamentals of electrochemical science*, 1st edn. Academic Press, San Diego, p 397

DT

Resistance overpotential \rightarrow ohmic overpotential

Resistor — An electrical circuit component that resists the flow of \rightarrow current. An ideal resistor obeys \rightarrow Ohm's

law, $U = I \times R$, for any given current or voltage. The \rightarrow SI derived unit of resistance is Ohm. Practical resistors are rated for maximum voltage, current flow, accuracy, and resistance value. Resistors are used in electric and electronic circuits. There are various types of resistors, such as fixed resistors, variable resistors (rheostat, potentiometer), and special resistors that do not obey Ohm's law, like thermistors, varistors, etc.

Refs.: [i] *The free dictionary by Farlex (An on-line, internet dictionary)* <http://encyclopedia.thefreedictionary.com/resistor>; [ii] Gates ED (2000) *Introduction to electronic*, 4th edn. Thomson Delmar Learning, New York, pp 33–36

YG

Respiration, electrochemical aspects — The function of the enzymes in the mitochondrial respiratory chain is to transform the energy from the redox reactions into an electrochemical proton gradient across the hydrophobic barrier of a coupling membrane. Cytochrome oxidase (EC 1.9.3.1, PDB 2OCC) is the terminal electron acceptor of the mitochondrial respiratory chain. Its main function is to catalyze the reaction of oxygen reduction to water using electrons from ferrocyanochrome c : $4H^+ + O_2 + 4e^- \rightleftharpoons 2H_2O$. Cytochrome oxidases can transport a maximum of eight protons across the membrane per oxygen molecule reduction. The first step in oxygen reduction by cytochrome c oxidase is a concerted two-electron process. The energy needed for the function of the H^+ -pump is liberated only in the last steps of water formation on the addition of third and fourth electrons independently of the reaction route. The stoichiometry of proton pumping by cytochrome oxidase is 0:2:2.

Refs.: [i] Volkov AG (2002) *Biocatalysis: electrochemical mechanisms of respiration and photosynthesis*. In: Volkov AG (ed.) *Interfacial catalysis*, Marcel Dekker, New York; [ii] Kharkats YuI, Volkov AG (1998) *Analytical Sci* 14:29

AV

Response time — Although this is often used as a synonym for \rightarrow time constant of an \rightarrow exponential decay, it has a more general meaning: For an exponential decay following the differential equation $dx/dt = -\lambda x$ and having the solution $x = x_0 e^{-\lambda t}$ the \rightarrow time constant is $\tau = \lambda^{-1}$. Of course, beside the time constant τ , any other values can be defined for specified ratios of x_0/x , e.g., $x_0/x = 0.5$, or $x_0/x = 0.1$, etc. The term response time is frequently used in connection with \rightarrow electrochemical detectors (and generally for detectors) when their ability to respond to a change of chemical composition of a solution has to be characterized. Supposed the concentration can be stepped with infinite speed from a small

value to a high value (which is practically never achievable), the signal response of a detector will grow, instead of decaying, and it can always be described by the following differential equation:

$$a_n \frac{d^{(n)}y}{dt^{(n)}} + a_{n-1} \frac{d^{(n-1)}y}{dt^{(n-1)}} + a_{n-2} \frac{d^{(n-2)}y}{dt^{(n-2)}} + \dots + a_1 \frac{dy}{dt} + a_0 y = C,$$

where a_0, a_1, \dots, a_n , and C are constants and y is the output signal of the detector. Frequently, higher-order derivatives can be neglected and the first order differential equation $a_1 \frac{dy}{dt} + a_0 y = 0$ with the solution $y(t) = \frac{1}{a_0} (1 - e^{-\frac{t}{\tau}})$ satisfactorily describes the response. The time constant is in this case $\tau = a_1/a_0$. The time constant τ can be obtained by least-square fitting of the experimental curves with the equation $y(t) = \frac{1}{a_0} (1 - e^{-\frac{t}{\tau}})$, or using the relation $\tau = 1.44T_{50}$ with T_{50} being the time necessary to reach 50% of the final value ($1.44 = 1/\ln 2$). Sometimes a delay in response can be simply taken into account by introduction of a delay time T_D : $y(t) = \frac{1}{a_0} (1 - e^{-\frac{t-T_D}{\tau}})$. The delay time T_D marks the time where the first-order differential equation starts to be a good approximation of the response. While a first-order response growth curve has the shape of an exponential approach of the final signal value without any inflection point, higher-order differential equations describe response curves with a turning point, i.e., a somewhat slower growth at the start.

Refs.: [i] Váňa J (1982) *Gas and liquid analyzers*. In: Svehla G (ed) *Wilson and Wilson's comprehensive analytical chemistry*, vol. XVII. Elsevier, Amsterdam; [ii] Hanekamp HB (1981) *Polarographic continuous-flow detection*. Ph.D. thesis Vrije Universiteit te Amsterdam, Amsterdam

FS

Response volume — In case of flow-through detectors (\rightarrow *flow-cell*) the volume v_r that flows through the detector with a flow rate f within the time interval corresponding to the time constant τ (\rightarrow *response time*): $v_r = \tau f$. The response volume is a measure of the quality of a detector.

Ref.: [i] Hanekamp HB (1981) *Polarographic continuous-flow detection*. Ph.D. thesis Vrije Universiteit te Amsterdam, Amsterdam

FS

Rest potential \rightarrow *potential*, subentry \rightarrow *rest potential*

Retarded electrode (also called sheltered electrode) — When a \rightarrow *potentiometric titration* ought to be followed by recording the first derivative this can be achieved by

using two identical electrodes (e.g., two \rightarrow *glass electrodes* for pH measurement, or two silver electrodes to measure the chloride activity) and sheltering one of them in a glass tube with a narrow opening on the bottom. When the solution in the beaker is constantly stirred, the sheltered electrode will always give a retarded potential and the potential difference between the sheltered and unsheltered electrodes will be proportional to the first derivative of the potential of the unsheltered electrode over time (constant stirring and constant rate of titrant addition provided). The glass tube of the sheltered electrode may be connected with a rubber bulb that allows the interior solution to be exchanged, or may be connected with some other apparatus to exchange the solution sequentially. This way a sequential measurement is possible, provided that the opening is so narrow that practically no mixing can happen without using the rubber bulb. The sheltered electrode was invented by \rightarrow *MacInnes* [i].

Refs.: [i] MacInnes DA, Jones PT (1926) *J Am Chem Soc* 48:2831;

[ii] MacInnes DA, Dole M (1929) *J Am Chem Soc* 51:1119

FS

Reverse mirage effect — A deflection signal commonly related to photothermal experiments in which the deflected probe light beam passes on the opposite side of the photoilluminated interface [i].

Ref.: [i] Terazima M, Hirota N, Braslavsky S, Mandelis A, Bialkowski S, Diebold G, Miller R, Fournier D, Palmer R, Tam A (2004) *Pure Appl Chem* 76:1083

FG

Reverse osmosis \rightarrow *osmosis*

Reverse pulse voltammetry — During reverse pulse voltammetry (RPV), the voltage profile is inverted compared to \rightarrow *normal pulse voltammetry* (NPV). The initial potential is usually placed at a potential where each molecule of the substrate is reduced/oxidized. The pulses of increasing amplitude move to a potential where the substrate undergoes no electron transfer. Due to this setup the obtained voltammograms are of mixed anodic-cathodic character. For reversible electrode reactions the applied potential profile enhances the response of reaction products whereas NPV favors the reactants. In another variant of this technique (constant potential pulse voltammetry) the initial potential is changed and all pulses are located at a selected potential where the substrate undergoes no electron transfer. Then all sampled currents are of opposite direction compared to the currents flowing at the initial potentials. The application of RPV allows easy detection of

following chemical reactions and adsorption of the electrode reaction products.

See → *differential pulse polarography*, → *differential pulse voltammetry*, → *normal pulse polarography*, and → *normal pulse voltammetry*.

Refs.: [i] Bard AJ, Faulkner LR (2001) *Electrochemical methods*, 2nd edn. Wiley, New York, pp 278–283; [ii] Stojek Z (2002) *Pulse voltammetry*. In: Scholz F (ed) *Electroanalytical methods*. Springer, Berlin

ZS

Reversible electrode → *reversibility*

Reversible electrode reaction → *reversibility*

Reversible fuel cell → *fuel cell*

Reversible hydrogen electrode → *hydrogen electrode*

Reversible redox reaction — The term is used in three different contexts: (a) The → *redox reaction* is **chemically reversible** if it can proceed in the two directions, i.e., from the reactants to products and in the reverse direction. (b) The redox reaction is **thermodynamically reversible** if it is at any moment in equilibrium. From the initial to the final state, it proceeds through a series of equilibrium states, thus proceeding infinitesimally slow and requiring an infinite length of time. An infinitesimal change in the direction of the driving force causes the direction of the process to reverse. (c) The redox reaction (or the → *electrode reaction*) is **electrochemically reversible** when the surface concentrations of both species of the redox couple obey the → *Nernst equation* at any potential difference applied at the electrode–solution interface (→ *nernstian electrode*). This is the case only when the → *charge transfer* at the → *interface* is much faster than all coupled → *mass transport* processes.

Ref.: [i] Bard AJ, Faulkner LR (2001) *Electrochemical methods. Fundamentals and Applications*, 2nd edn. Wiley, New York

VM

Reversible square-wave voltammogram — is a square-wave voltammogram (→ *square-wave voltammetry*) of a reversible electrode reaction (see → *reversible redox reaction*). Figure 1 shows a dimensionless theoretical square-wave (SW) voltammogram of a reversible electrode reaction of a dissolved → *redox couple* at a planar → *electrode*, assuming a semi-infinite planar diffusion model (→ *diffusion*). The → *voltammogram* consists of three current components, designated as forward, backward (or reverse), and net response. The net response is a bell-shaped curve, whereas the forward and reverse components vary slightly in their shape, depending on the product between the number of electrons (n) and

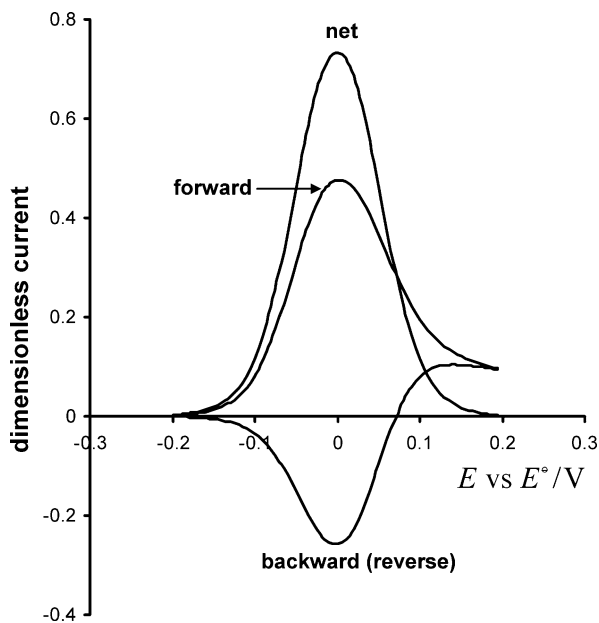

Reversible square-wave voltammogram — **Figure**. Theoretical dimensionless square-wave voltammogram of a reversible electrode reaction (see → *reversible redox reaction*) of a dissolved redox couple at a planar electrode assuming a semi-infinite diffusion model simulated with $nE_{sw} = 50$ mV and a scan increment of the staircase ramp of 5 mV (see → *square-wave voltammetry*)

the amplitude of the square-wave potential modulation (E_{sw}) (see → *square-wave voltammetry*). The → *peak potential* of the net component is equal to the → *formal potential* of the electrode reaction. The peak potential separation between the forward and backward component depends on the product nE_{sw} , being zero for $nE_{sw} = 70$ mV. The peak potentials of all components of the response are insensitive to the frequency of the potential modulation, which is one of the criteria for evaluation of the reversibility of the electrode reaction. The → *peak current* of the net component is a linear function of the bulk concentration of the electroactive form and the square-root of the frequency. The latter feature can serve as an additional criterion for a reversible electrode reaction controlled by a semi-infinite diffusion at a planar electrode. An amplitude value of $nE_{sw} = 50$ mV is optimal for analytical purposes as it produces the maximum ratio of the peak current and the → *half-peak width* of the net component.

Ref.: [i] Lovrić M (2002) *Square-wave voltammetry*. In: Scholz F (ed) *Electroanalytical methods. Guide to experiments and applications*. Springer, Berlin, p III; [ii] Mirčeski V, Komorsky-Lovrić Š, Lovrić M (2007) *Square-wave voltammetry*. In: Scholz F (ed) *Monographs in Electrochemistry*. Springer, Berlin

VM

Reversibility — This concept is used in several ways. We may speak of chemical reversibility when the same reaction (e.g., \rightarrow cell reaction) can take place in both directions. Thermodynamic reversibility means that an infinitesimal reversal of a driving force causes the process to reverse its direction. The reaction proceeds through a series of equilibrium states, however, such a path would require an infinite length of time. The electrochemical reversibility is a practical concept. In short, it means that the \rightarrow Nernst equation can be applied also when the actual electrode potential (E) is higher (anodic reaction) or lower (cathodic reaction) than the \rightarrow equilibrium potential (E_e), $|E| \geq E_e$. Therefore, such a process is called a reversible or nernstian reaction (reversible or nernstian system, behavior). It is the case when the \rightarrow activation energy is small, consequently the \rightarrow standard rate constants (k_s) and the \rightarrow exchange current density (j_0) are high.

If $j_0 \gg j$, i.e., $j/j_0 \rightarrow 0$ by rearranging the respective \rightarrow Butler-Volmer equation, [see Eq. (2) there] we obtain

$$c_{\text{O}}(x=0)/c_{\text{R}}(x=0) = (c_{\text{O}}^*/c_{\text{R}}^*) \exp [nf(E - E_e)] . \quad (1)$$

By substituting $c_{\text{O}}^*/c_{\text{R}}^*$ from the Nernst equation (2)

$$c_{\text{O}}^*/c_{\text{R}}^* = \exp [nf(E_e - E_c^{\ominus'})] \quad (2)$$

into Eq. (1)

$$c_{\text{O}}(x=0)/c_{\text{R}}(x=0) = \exp [nf(E - E_c^{\ominus'})] \quad (3)$$

or

$$E = E_c^{\ominus'} + \frac{RT}{nF} \ln \frac{c_{\text{O}}(x=0)}{c_{\text{R}}(x=0)} , \quad (4)$$

where c_{O}^* and c_{R}^* are the bulk or the equilibrium concentrations of the oxidized and reduced forms of the reacting species, respectively, $c_{\text{O}}(x=0)$ and $c_{\text{R}}(x=0)$ are the concentrations of these species at the electrode surface, $E_c^{\ominus'}$ is the formal electrode potential, and $f = F/RT$. It follows that the Nernst equation expresses the relationship between the surface concentrations and the electrode potential regardless of the current flow. The surface equilibrium is a consequence of the very fast \rightarrow charge transfer kinetics. Equation (3) contains no kinetic parameter. Kinetic parameter can be determined when irreversible kinetics prevails (\rightarrow irreversibility).

It should also be mentioned that the appearance of the reversible behavior depends on the relative value of k_s and \rightarrow mass transport coefficient (k_m), since no equilibrium exists between the surface and bulk concentrations, reactants are continuously transported to the electrode surface by \rightarrow mass transport (\rightarrow diffusion).

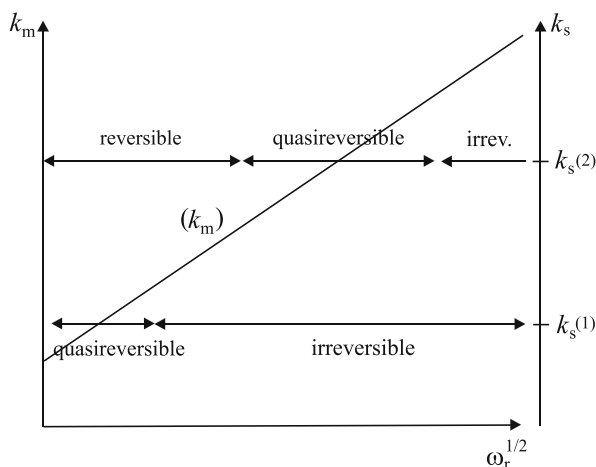

Reversibility — Figure 1. The illustration of the reversibility problem. The standard rate constants ($k_s(1)$ and $k_s(2)$) are characteristic to the charge transfer rate of the given systems. The diffusion rate constants (k_{mR} or k_{mO}) are varied by the rotation rate of the electrode. If $k_s \gg k_m$ the system is reversible, while in the case of $k_m \gg k_s$ irreversible behavior can be observed. The values of the diffusion coefficients are taken equal for both systems

Of course, the current can never be higher than the rate of the most hindered (slowest) step which is either the electron transfer or the mass transport. The problem of reversibility in terms of the relative ratio of k_s and k_m is illustrated in Fig. 1. Two systems with different electron transfer rates ($k_s(1)$ and $k_s(2)$) are considered and the effect of forced convection (the variation of the rotation rate of the electrode (ω_r)) is presented. The rate

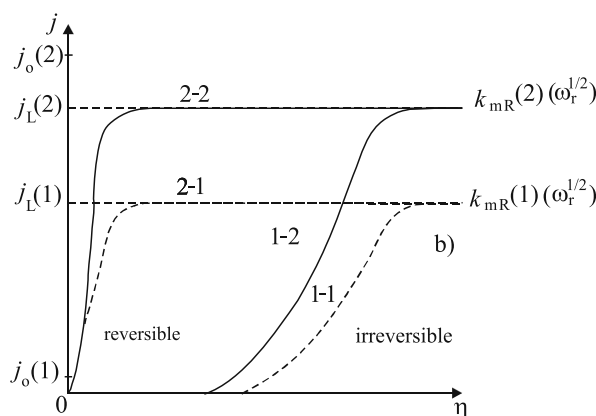

Reversibility — Figure 2. Steady-state polarization (j - η) curves for reversible ($j_o(2)$) and irreversible ($j_o(1)$) systems, respectively, at two different stirring rates. Curves are according to the following parameters: (1-1): $j_o(1)$ and $k_{mR}(1)$, (1-2): $j_o(1)$ and $k_{mR}(2)$, (2-1): $j_o(2)$ and $k_{mR}(1)$ and (2-2): $j_o(2)$ and $k_{mR}(2)$. Same diffusion coefficients for both systems are considered

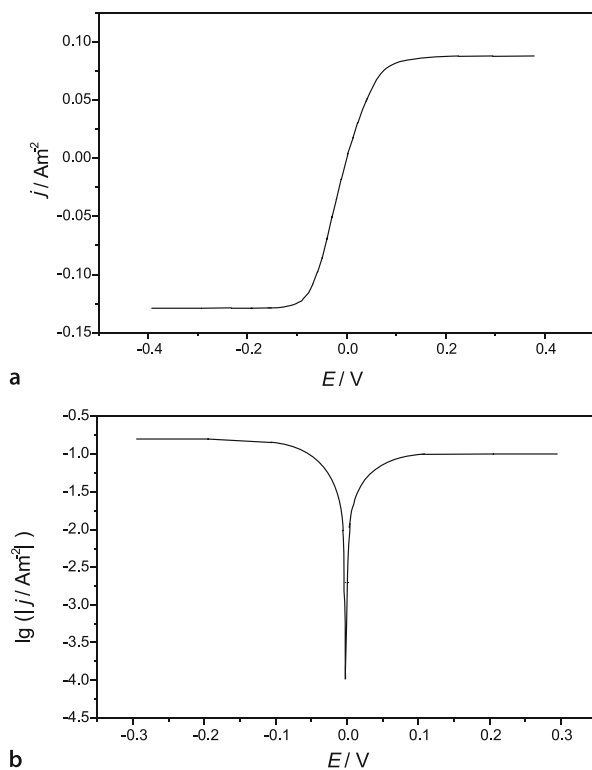

Reversibility — **Figure 3.** Reversible system. **a** Current–potential curve and **b** $\lg |j|$ – E plot. Characteristic parameters are: $E_e = 0.0$ V, $j_0 = 50$ A m $^{-2}$, $n = 1$, $D_R = 5 \times 10^{-10}$ m 2 s $^{-1}$, $D_O = 10^{-9}$ m 2 s $^{-1}$, $c_R^* = c_O^* = 10^{-4}$ mol dm $^{-3}$, $\omega_r = 50$ s $^{-1}$, $v = 10^{-6}$ m 2 s $^{-1}$, $\alpha_a = \alpha_c = 0.5$, $T = 298.15$ K

constants (k_{red} and k_{ox}) can be altered by the potential applied. The effect of the overpotential on a reversible (j_0 (2) is very large) and an irreversible (j_0 (1) is small) system, respectively, is schematically shown in Fig. 2. For the sake of simplicity the values of the diffusion coefficient of the electroactive species in both systems are equal.

The current–potential relationship for a reversible redox system (note the very high value of the exchange current density) is displayed in Fig. 3. As can be seen in Fig. 3(b) there is no \rightarrow Tafel region. On the other hand, in the case of an irreversible system, the Tafel region may spread over some hundreds of millivolts if the stirring rate is high enough (see there).

See also \rightarrow nernstian electrode, and \rightarrow reversible redox reaction.

Refs.: [i] Inzelt G (2002) *Kinetics of electrochemical reactions*. In: Scholz F (ed) *Electroanalytical methods*. Springer, Berlin, pp 29–47; [ii] Bard AJ, Faulkner LR (2001) *Electrochemical methods*, 2 $^{\text{nd}}$ edn. Wiley, New York, pp 87–155

Reynier cell — This was a copper–zinc \rightarrow battery with sodium hydroxide in the anodic compartment. See also \rightarrow Daniell cell, \rightarrow zinc, \rightarrow Zn $^{2+}$ /Zn electrodes, \rightarrow Zn $^{2+}$ /Zn(Hg) electrodes, \rightarrow zinc–air batteries (cell), and \rightarrow Leclanché cell.

Ref.: [i] Hauck WP (1883) *Die Galvanischen Batterien, Accumulatoren und Thermosäulen*, 2 $^{\text{nd}}$ edn. Hartleben's Verlag, Wien

FS

Reynier's battery — This was an assembly of \rightarrow Daniell cells. See also \rightarrow zinc, \rightarrow Zn $^{2+}$ /Zn electrodes, \rightarrow Zn $^{2+}$ /Zn(Hg) electrodes, \rightarrow zinc–air batteries (cell), and \rightarrow Leclanché cell.

Ref.: [i] Hauck WP (1883) *Die Galvanischen Batterien, Accumulatoren und Thermosäulen*, 2 $^{\text{nd}}$ edn. Hartleben's Verlag, Wien

FS

Reynolds number — The Reynolds number, Re , is defined by the ratio of inertial forces to viscous forces, or $vL\rho/\eta$ for flow rate, v , characteristic length, L , density of the medium, ρ , and \rightarrow viscosity of the medium, η . It has been used electrochemically for an estimation of laminar flow against turbulent flow in \rightarrow hydrodynamic voltammetry for controlling flow rates [i]. Flows with Re less than ca. 2300 are laminar flows although the transition to a turbulent flow depends on flow configuration.

Ref.: [i] Newman JS (1991) *Electrochemical systems*. Prentice-Hall, Englewood Cliffs, p 289

KA

critical Reynolds number — Transition between turbulent and laminar flow is often reported as occurring at the critical Reynolds number (Re_c), this is dependent on the specific \rightarrow flow-cell configuration and should be determined experimentally.

AF

rH(r_H) value — Obsolete term proposed by W.M. Clark, and defined as $rH = -\log p_{\text{H}_2}$. Here, p_{H_2} is the \rightarrow partial pressure of hydrogen corresponding to the \rightarrow redox potential E of a redox system. The rH value is related to the redox potential E according to $rH = \frac{E}{0.02958 [\text{V}]}$ (for 25 °C). The rH value was proposed in the hope of obtaining a measure of the reductive (or oxidative) power of a redox system independent of \rightarrow pH. Since that is possible only for those redox systems that involve an equal number of \rightarrow electrons and \rightarrow protons, such as the \rightarrow quinhydrone electrode, Clark later discouraged the use of rH values.

Ref.: [i] Clark WM (1928) *The determination of hydrogen ions*, 3 $^{\text{rd}}$ edn. Williams & Wilkins, Baltimore, p 387

FS

RHE → reversible hydrogen electrode

Riesenfeld, Ernst Hermann



(Courtesy of Johan Riesenfeld, Uppsala)

(Oct. 25, 1877, Brieg, then Germany, now Brzeg, Poland – May 19, 1957, Stockholm, Sweden) Ph.D. 1901 in Göttingen, 1913 Professor in Freiburg im Breisgau (Germany), after 1920 Professor at the University of Berlin. Because of the Nazi regime, he lost his position in Berlin in 1934 and moved to Sweden, where he worked until 1952 at the Nobel Institute. Riesenfeld was married to the sister of the wife of → Arrhenius. His Ph.D. thesis [i, ii], guided by → Nernst, was devoted to studies of the electrochemical properties of interfaces between two immiscible electrolyte solutions. This pioneering work is remembered as the starting point of what is now known as electrochemistry at the → interface between two immiscible electrolyte solutions. Nernst and Riesenfeld developed a highly sensitive torsion displacement balance which is now known as ‘Nernst balance’ [iii]. Beside textbooks on inorganic chemistry, he has also written a biography of Arrhenius [iv].

Refs.: [i] Riesenfeld EH (1901) *Ueber elektrolytische Erscheinungen und elektromotorische Kräfte an der Grenzfläche zweier Lösungsmittel* (On electrolytic phenomena and electromotive forces at the interface between two solvents). Dieterichsche Universitäts-Buchdruckerei, Göttingen; [ii] Nernst W, Riesenfeld EH (1901) *Ann Phys* 8:600; [iii] Nernst W, Riesenfeld EH (1903) *Chem Ber* 36:2086; [iv] Riesenfeld EH (1931) *Svante Arrhenius*. Akademische Verlagsgesellschaft, Leipzig

Ring method — Method to determine the → interfacial tension in liquid–gas systems introduced by Lecomte du Noüy [i]. It is based on measuring the force to detach a ring or loop of a wire from the surface of a liquid. The method is similar to the → Wilhelmy plate method when used in the detachment mode [ii]. See also → electrocapillarity, → electrocapillary curve, → Gibbs–Lippmann equation, → Wilhelmy plate (slide) method, → drop weight method, → Lippmann capillary electrometer.

Refs.: [i] Lecomte du Noüy P (1919) *J Gen Physiol* 1:521; [ii] Adamson AW, Gast AP (1997) *Physical chemistry of surfaces*, 6th edn. Wiley, New York, pp 21

FS

Ritter, Johann Wilhelm



(Dec. 16, 1776, Samitz, Silesia, Germany, now Zamienice, Poland – Jan. 23, 1810, Munich, Germany) Ritter started his career as apothecary, studied at Jena University, and discovered that decomposition of silver chloride proceeded most efficiently with invisible radiation beyond the violet range of the spectrum (later called ultraviolet light). Ritter was particularly interested in electrical excitation of muscles and sensory organs and the electrophysiology of plants. He constructed the first dry cell 1802, the first rechargeable battery 1803. He was a member of the Bavarian Academy of Sciences.

Ref.: [i] Magnusson M (ed) (1990) *Chambers biographical dictionary*. W & R Chambers, Edinburgh

RH

Roberts cell — This was a → battery consisting of a tin and a platinum electrode in dilute nitric acid.

Ref.: [i] Hauck WP (1883) *Die Galvanischen Batterien, Accumulatoren und Thermosäulen*, 2nd edn. Hartleben's Verlag, Wien

FS

Rocking-chair batteries — Rechargeable batteries (→ battery), based on two intercalation compounds as the → cathode and → anode (→ insertion electrodes), in which the guest ion is transferred from the cathode host to the anode during discharge, and the reverse reaction takes place during the charging action. For example, Li_xCoO_2 cathode releases Li^+ -ions according to the reaction: $\text{Li}_x\text{CoO}_2 \rightleftharpoons x\text{Li}^+ + xe^- + \text{CoO}_2$, which are further inserted to, e.g., a graphite anode: $6\text{C} + x\text{Li}^+ + xe^- \rightleftharpoons \text{Li}_x\text{C}_6$. The concept of rocking-chair battery was originally proposed by M. Armand in 1980 (In: *Materials for Advanced Batteries*, Murphy DW, Broadhead J and Steele BCH (eds), Plenum Press, New York, p. 145). The only feasible rocking-chair systems to date are based on lithium ions, although other ions, including multivalent ones, are studied as alternatives.

These batteries are also often called “swing cells” or “shuttlecock batteries”, or, in general, “Li-ion cells” (→ *lithium batteries*). Suitable anodes for rocking-chair batteries include different forms of graphitic carbons, hard carbons, and (or) their mixtures. Studies are conducted also with alternative anodic hosts, such as titanium oxide, tin oxide, etc. A great variety of transition metal oxides and sulfides (pure or mixed) may serve as a cathode for these batteries. Depending on its nature and on the nature of the aprotic organic electrolyte used, 2, 3, 4, and even 5 V batteries can be created. Using composite carbonaceous anode, with LiCoO₂ cathode, the first rocking chair battery was commercialized by Sony Corporation in 1991 and since then the market of these batteries has been steadily increasing.

Refs.: [i] Besenhard J, Sitte W (2001) *Electroactive materials*. Springer, Wien, p 129; [ii] Dell RMJ, Rand DA (2001) *Understanding batteries*. Royal Society of Chemistry, London, p 264; [iii] Nazri GA, Pistoia G (eds) (2003) *Lithium batteries: science and technology*. Springer, Boston, p 344; [iv] Van Schalkwijk W, Scrosati B (eds) (2002) *Advances in lithium-ion batteries*. Springer, Berlin p 524

ML

Roginskii–Zel'dovich kinetics → adsorption kinetics

Rollet cell — This was a variant of the → *Daniell cell*. See also → *zinc*, → *Zn²⁺/Zn electrodes*, → *Zn²⁺/Zn(Hg) electrodes*, → *zinc-air batteries (cell)*, and → *Leclanché cell*.

Ref.: [i] Hauck WP (1883) *Die Galvanischen Batterien, Accumulatoren und Thermoäulen*, 2nd edn. Hartleben's Verlag, Wien

FS

Room-temperature molten salt (RTMS) — also called room-temperature → *ionic liquid*, is a salt having low melting point, typically below 100 °C, for example, 1-methyl-3-octylimidazolium bis(trifluoromethylsulfonyl)imide. Negligibly low vapor pressure, reasonable → *conductivity*, wide electrochemical potential window (→ *electrochemical window*), fairly chemical inertness, and innumerable variety, are main virtues of RTMS, which hence are expected to be a promising alternative to molecular solvents [i]. When both cations and anions constituting an RTMS are hydrophobic enough, the RTMS is immiscible with water and forms an RTMS-W two-phase system. This new liquid-liquid interface is promising in extraction, two-phase organic synthesis (→ *two-phase electrolysis*), and → *electroanalysis*, e.g., → *salt bridge* [ii] and ion sensing [iii]. The RTMS|W interface can be electrochemically either non-polarized or polarized, depending on the constituent ions and also ions in the aqueous phase [iv].

Refs.: [i] Rogers RD (ed) (2005) *Ionic liquids IIIA, IIIB*. Amer Chem Soc, Washington; [ii] Kakiuchi T, Yoshimatsu M (2006) *Bull Chem Soc Jpn* 79:1017; [iii] Nishi N, Imakura S, Kakiuchi T (2006) *Anal Chem* 78:2726; Nishi N, Murakami H, Imakura S, Kakiuchi T (2006) *ibid* 78: in press; [iv] Kakiuchi T, Tsujioka N, Kurita S, Iwami Y (2003) *Electrochem Commun* 5:159; Kakiuchi T, Tsujioka N (2003) *ibid* 5:253

TK

Root mean square (RMS) — is a statistical measure of the size of a varying quantity. The RMS for a series of N discrete values x_i is given by: $x_{\text{RMS}} = \sqrt{\frac{1}{N} \sum_{i=1}^N x_i^2}$, whereas for the case of a continuously varying function $f(\tau)$, defined over the interval ($t_1 \leq \tau \leq t_2$), it is: $f_{\text{RMS}} = \sqrt{\frac{1}{t_2-t_1} \int_{t_1}^{t_2} [f(\tau)]^2 dt}$. If $f(\tau)$ is a periodic function, an integer number of cycles has to be considered. It is related to the arithmetic mean and the standard deviation of a population by the following equation: $x_{\text{RMS}}^2 = \bar{x}^2 + \sigma^2$. The root mean square is also known as the quadratic mean [i].

Ref.: [i] Hogg RV, Ledolter J (1991) *Applied statistics for engineers and physical scientists*. Prentice Hall, New Jersey

FG

Rotating disk electrode (RDE) — It is a small metal disk inlaid into an insulating cylinder having a large base (→ *electrode*, → *electrode geometry*). The disk is situated in the center of the base. The cylinder is mounted on a metallic axle that is connected to an electric motor. The axle is perpendicular to the base and lies in the axis of the cylinder. The axle is connected to a → *potentiostat* by graphite brushes and to the metal disk by a wire. Alternatively, it may bear a metallic bell that rotates in a mercury pool to obtain noiseless electrical contact with the potentiostat. When the cylinder rotates, the solution near its base moves angularly, radially, and axially. Because of the friction, a thin layer of solution that is in contact with the base follows the rotation of the cylinder. Due to the viscosity of solution this angular movement extends into a thicker layer of solution, but its rate decreases exponentially with the distance from the surface of the cylinder. The rotation of the solution induces a centrifugal force that causes a radial movement of the solution. To preserve the pressure, the latter is compensated by the axial flux from the bulk of the solution. The components of the fluid velocity depend on the angular velocity of the disk ($\omega = 2f\pi$, where f is the rotation frequency in hertz), on the radial distance from the center of the disk (r), on the coefficient of kinematic → *viscosity* of the fluid (ν), and on the axial distance from the surface of the disk (y): $v_r = r\omega F(y)$, $v_\phi = r\omega G(y)$,

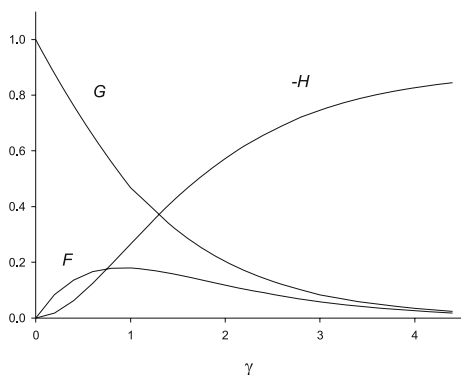

Rotating disk electrode (RDE) — Figure. Dependence of functions F , G , and H on the dimensionless distance from the rotating disk [iii]. See also → *Levich equation*

and $v_y = \sqrt{\omega\nu}H(\gamma)$, where $\gamma = y\sqrt{\omega/\nu}$. The functions $F(\gamma)$, $G(\gamma)$, and $H(\gamma)$ are shown in the figure. Around the center of the base of the cylinder, where the metal disk lies, the axial component of the solution velocity is most important, since the electroactive material is transported towards the surface in this direction only. Under chronoamperometric conditions, a → *diffusion layer* develops at the electrode surface and extends as far into the solution as the flux at the surface is not equal to the rate of mass transport in the bulk of the solution. Under → *steady-state* conditions and the → *laminar flow* of the solution, the distance δ depends on the electrode rotation rate: $\delta = 1.61D^{1/3}\nu^{1/6}\omega^{-1/2}$, where D is the diffusion coefficient [i]. In → *cyclic voltammetry*, the rotating disk electrode may operate either under steady-state or → *transient* conditions. If the scan rate is very slow, the response is a wave with a → *limiting current* which is proportional to the square root of the rotation rate. At fast scan rates, a → *voltammetric peak* appears during the forward, but not the reverse scan [ii].

Refs.: [i] Levich VG (1962) *Physicochemical hydrodynamics*. Prentice-Hall, Englewood Cliffs; [ii] Opekar F, Beran P (1976) *J Electroanal Chem* 69:1; [iii] Pleskov YuV, Filinovski VYu (1976) *The rotating disk electrode*. Consultants Bureau, New York

MLo

Rotating ring disk electrode (RRDE) — This electrode consists of a thin metallic ring inlaid around the metallic disk that is situated in the center of the base of the insulating cylinder. Because of the radial component of the solution movement, which is caused by the rotating of the cylinder, the products of the electrode reaction formed on the disk electrode are carried over the

insulating gap towards the ring electrode where they can be detected and analyzed. This electrode is characterized by two important functions, the collection efficiency and the shielding efficiency, which both depend on the thickness of the gap and the ring [i]. Rotating ring disk electrodes are used for the investigation of unstable intermediates of electrode reactions [ii, iii].

Refs.: [i] Albery WJ, Bruckenstein S (1966) *Trans Faraday Soc* 62:1920; [ii] Endo K, Katayama Y, Miura T (2005) *Electrochim Acta* 50:2181; [iii] Medard C, Lefevre M, Dodelet JP, Jaouen F, Lindbergh G (2006) *Electrochim Acta* 51:3202; [iv] Albery WJ, Hitchman ML (1971) *Ring-disk electrodes*. Oxford University Press

MLo

Rotating wire electrode — When a metal wire is rotating in a solution and used as an → *electrode* for → *current* measurements, the current will be enhanced due to the enhanced → *mass transport* of the → *depolarizer* to the electrode surface. However, since the hydrodynamic conditions are usually rather difficult to control at a rotating wire, especially when the wire is **not** a highly symmetric cylinder rotating around its own axis, the rotating wire electrode found only some application as an → *indicator electrode* in → *amperometric titrations*.

FS

Roughness factor — The ratio of true electrode surface area A_{real} (→ *electrode surface area*) to geometrical surface area $A_{\text{geom}}f_r = A_{\text{real}}/A_{\text{geom}}$ (→ *electrode surface area*). Smooth electrode surfaces of well-polished metals show values of f_r only somewhat above one; mechanically, chemically, or electrochemically roughened metal surfaces have values of f_r well above 1 up to several hundred. In case of porous electrodes the inner surface area of the three-dimensional electrode body has an active surface area considerably larger than the outer geometric surface area, ratios up to several thousand are observed. In this case the term roughness factor is inappropriate.

Ref.: [i] Jarzabek G, Borkowska Z (1997) *Electrochim Acta* 42:2915

RH

RRDE → *rotating ring disk electrode*

Ruben cell — This is a zinc–mercuric oxide alkaline cell, more commonly called a mercury → *battery*, a type of primary (nonrechargeable) cell, developed by Samuel Ruben during World War II in response to a requirement for batteries with a high capacity-to-volume ratio which would withstand storage under tropical conditions. It was licensed to the P.R. Mallory Co., which

later became Duracell, Intl. The mercuric oxide cell was used for applications that required a high \rightarrow *energy density* and a flat voltage curve.

Mercuric-oxide cells are constructed with zinc anode and pure mercuric oxide, or a mixture of mercuric oxide with manganese dioxide as the cathode. Highly concentrated sodium hydroxide or potassium hydroxide are used as an \rightarrow *electrolyte* at 30–45% by weight concentration. Zinc oxide is also dissolved in varying amounts in solution to suppress hydrogen evolution. Sodium hydroxide cells have a nearly constant voltage at low discharge currents, making them ideal for hearing aids, calculators, and electronic watches. Potassium hydroxide cells, in turn, provide a constant voltage at high currents, making them suitable for applications requiring current surges, e.g., flash cameras and watches with backlights. Potassium hydroxide cells have a better performance at lower temperatures. Mercury cells have a very long shelf life, up to 10 years. Electrode reactions are:

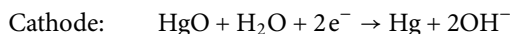

The overall cell reaction occurring in a mercuric oxide-zinc cell is:

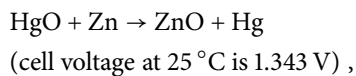

and could be represented as $-\text{Zn}_s|\text{ZnO}_s|\text{KOH}_{\text{aq}}|\text{HgO}_s|\text{Hg}_l+$.

Mercury batteries with cathodes of a mixture of mercuric oxide and manganese dioxide have a voltage of 1.4 V and a more sloping discharge curve.

Due mainly to the environmental problems associated with \rightarrow *mercury*, the sale of mercury batteries has been banned in many countries during the past years, and they were banned by the International Electrochemical Commission (IEC) and the American National Standards Institute (ANSI). They have been replaced by alkaline-manganese dioxide, zinc/air, silver oxide, and lithium batteries.

Refs.: [i] Naylor D (2002) *Mercury oxide cells*. In: Linden D, Reddy TB (eds) *Handbook of batteries*, 3rd edn. McGraw-Hill, New York; [ii] Crompton TR (2000) *Battery reference book*, 3rd edn. Newness, Oxford

DA, GS

R

Rubidium cation conductors \rightarrow *solid electrolyte*

Rubidium conducting solid electrolyte \rightarrow *solid electrolyte*

S

Sacrificial anode — is a piece of metal used as an \rightarrow *anode* in electrochemical processes where it is intended to be dissolved during the process. In \rightarrow *corrosion protection* it is a piece of a “non-noble” metal or metal alloy (e.g., magnesium, aluminum, zinc) attached to the metal to be protected. Because of their relative \rightarrow *electrode potentials* the latter is established as the \rightarrow *cathode* and thus immune to corrosion. In \rightarrow *electroplating* the metal used as anode may serve as a source for replenishing the electrolyte which is consumed by cathodic deposition. The sodium–lead alloy anode used in the electrochemical production of tetraethyl lead may also be considered as a sacrificial anode.

RH

Salinity — The conventional salinity (S) of \rightarrow *seawater* is defined relative to the chlorinity (Cl), which is the chlorine equivalent of the total mass of halides that can be precipitated from 1 kg of seawater by the addition of silver nitrate. The relationship is: $S = 1.80655 \times Cl$. The total mass of dissolved solids (S_T) is related to the conventional salinity by the equation: $S_T = 1.00544 \times S$.

Ref.: Millero FJ (1974) *Seawater as a multicomponent electrolyte solution*. In: Goldberg ED (ed) *The sea*, vol. 5. Wiley, New York, p 3

ŠKL

Salt bridge — Bringing the respective electrolyte solutions of two \rightarrow *half-cells* into contact will often make the different solvents and/or electrolytes meet. The different properties, in particular \rightarrow *mobilities* of the participating ions, create a \rightarrow *liquid junction potential*. Depending on the actual composition of the used solutions several ten millivolts can be observed. In order to avoid this undesirable contribution to a cell voltage measurement a salt bridge is used. The common principle of various available types is a tube of an inert material filled with a solution containing an electrolyte with approximately equal mobilities of the cation and the anion (e.g., KNO_3 , KCl) with the ends of the tube immersed in the electrolyte solution of the half cells. Because no mixing of the solution of the half-cells occurs this cannot cause a liquid junction potential. The liquid junction potentials established at both ends of the tube of the salt bridge may even cancel each other. Typical designs are:

See also \rightarrow *flowing junction*, \rightarrow *diffusion potential*, \rightarrow *Luggin probe*, \rightarrow *MacInnes*.

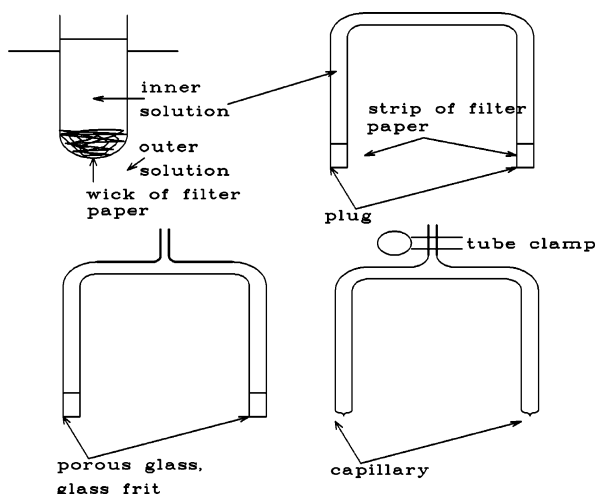

Salt bridge — Figure

Refs.: [i] Holze R (2001) *Elektrochemisches Praktikum*. Teubner, Stuttgart; [ii] Bard AJ, Faulkner LR (2001) *Electrochemical methods*, 2nd edn. Wiley, New York

RH

Sample — A specimen or part of a given chemical system that shows the kind and quality of the whole [i].

Ref.: [i] Harris D (2002) *Quantitative chemical analysis*. WH Freeman, New York

FG

Sample mean (\bar{x}) — The \rightarrow *mean* of a limited set of data [i].

Ref.: [i] Skoog D, West D, Holler F, Crouch S (2003) *Fundamentals of analytical chemistry*, 8th edn. Brooks/Cole, Belmont

FG

Sampled current voltammetry — Voltammetry using current data acquired using current sampling (see \rightarrow *current sampling*). Recording of current responses for most voltammetric techniques is based on some form of current sampling. An older name for sampled current voltammetry is ‘fast voltammetry’.

AMB

Sampling rate — The speed at which samples are read and converted into a voltage or a digital expression. The \rightarrow *Nyquist’s theorem* establishes that the sampling rate must be greater than twice the maximum frequency component in the signal to be acquired to avoid the \rightarrow *aliasing* of data [i].

Ref.: [i] Engineering Staff Analog Devices Inc. (2005) *The data conversion handbook*. Newness, Oxford

FG

Sand cell — This was essentially a \rightarrow *Cruikshank pile* where the acidic solution in the trough was solidified with sand so that the battery could easily be transported.

Ref.: [i] Hauck WP (1883) *Die Galvanischen Batterien, Accumulatoren und Thermosäulen*, 2nd edn. Hartleben's Verlag, Wien

FS

Sand equation — Consideration of the concentration $c_{(x=0,t)}$ at a planar working electrode in contact with a stagnant (unstirred) electrolyte solution for a reaction, where the oxidized species in the bulk is present at a concentration c^* and the reduced species is initially absent with an applied constant current I , yields

$$c_{(x=0,t)} = c^* - \frac{2It^{1/2}}{nFA\sqrt{D_{\text{ox}}\pi}}$$

for the concentration $c_{(x=0,t)}$ of the oxidized species in front of the electrode ($x = 0$) as a function of time t . At a characteristic time τ (called \rightarrow *transition time*) $c_{(x=0,\tau)}$ drops to zero. At this point the equation can be rewritten

$$\frac{I\tau^{1/2}}{c^*} = \frac{nFA\sqrt{D_{\text{ox}}\pi}^{1/2}}{2} = 85.5n\sqrt{D_{\text{ox}}A} \left[\frac{\text{mAs}^{1/2}}{\text{mM}} \right]$$

with the electrode surface area A in cm^2 . This equation is called Sand equation [i]. After time τ has passed, the flux of oxidized species no longer will support the applied current i , and the electrode potential jumps to another value where another electrode reaction can proceed.

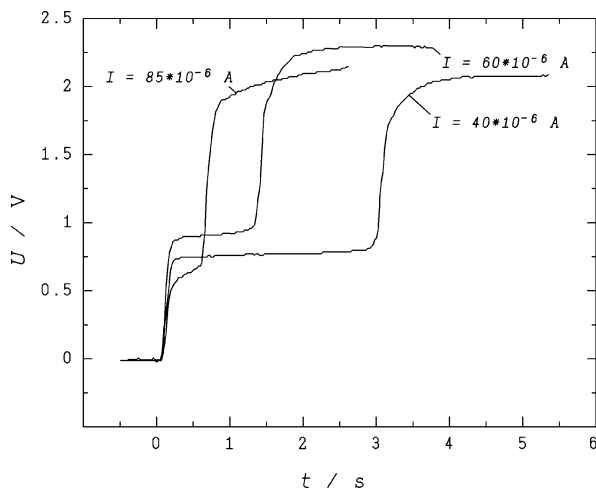

Sand equation — Figure

In a typical experiment employing a \rightarrow *hanging mercury drop electrode* in contact with an aqueous solution of $10 \text{ mmol L}^{-1} \text{ Cd}(\text{CH}_3\text{COO})_2$ and $1 \text{ mol L}^{-1} \text{ KCl}$ at different currents (as indicated) potential–time curves were observed.

As expected the product of square root of transition time and current is constant. See also \rightarrow *chronopotentiometry*.

Refs.: [i] Sand HJS (1901) *Philos Mag* 1:45; [ii] Bard AJ, Faulkner LR (2001) *Electrochemical methods*, 2nd edn. Wiley, New York

RH

Satory cell — This \rightarrow *battery* was developed by Karl Satory and it was a zinc–air battery. See also \rightarrow *zinc*, \rightarrow *Zn²⁺/Zn electrodes*, \rightarrow *Zn²⁺/Zn(Hg) electrodes*, \rightarrow *zinc–air batteries (cell)*, and \rightarrow *Leclanché cell*.

Ref.: [i] Hauck WP (1883) *Die Galvanischen Batterien, Accumulatoren und Thermosäulen*, 2nd edn. Hartleben's Verlag, Wien

FS

Saturated calomel electrode \rightarrow *calomel electrode*

Sauerbrey-equation \rightarrow *quartz crystal microbalance*

Scan rate \rightarrow *potential sweep rate*

Scanning electrochemical microscopy (SECM) — A \rightarrow *scanning probe technique* that is used to probe surface reactions and also serves as an electrochemical tool. It differs from other scanning probe methods like scanning tunneling (STM) and atomic force microscopy (AFM) in that well-developed electrochemical methods are used to quantitatively probe the chemistry of a system. SECM is based on the measurement of the current through an \rightarrow *ultramicroelectrode* (UME) tip (e.g., an electrode with a diameter on the order of 1 to 25 μm) when it is held constant or moved in a solution in the vicinity of a system. Systems, which can be electrode surfaces, liquid/liquid interfaces, biological samples, and surface structures in liquid environments, perturb the electrochemical response of the tip and this perturbation provides information about the nature and properties of the system with micrometer and nanometer resolution. SECM is also useful for imaging and studying the uptake or release of chemical species from a surface, including processes in biological cells. SECM combines the virtues of electrochemistry at UMEs with the application of piezoelectric elements to position the tip in the x, y, z planes, as in STM. Steady-state SECM measurements are simpler than, but analogous to those with \rightarrow *thin layer cells*, \rightarrow *rotating ring-disk electrodes*, and \rightarrow *interdigitated array electrodes*.

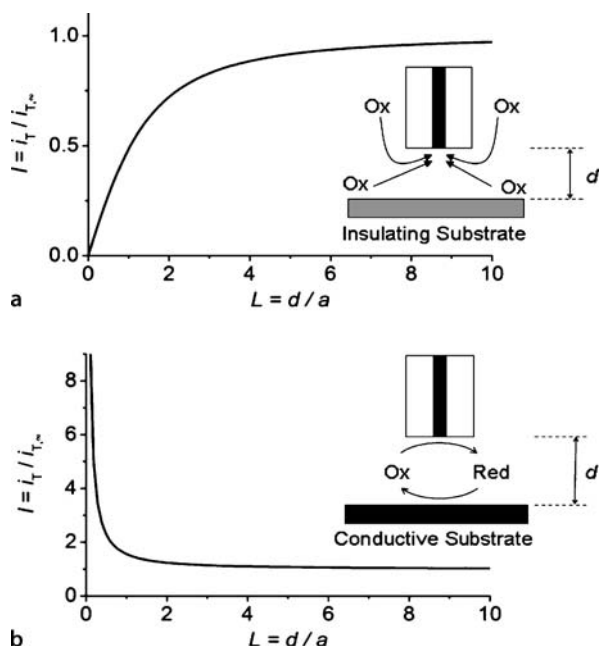

Scanning electrochemical microscopy (SECM) — Figure 1. SECM principles: approach curves on insulating (a) and conductive (b) substrates. Negative feedback is observed on an insulating substrate and positive feedback is observed on a conductive substrate

There are several modes of operation of the SECM. In the tip generation–substrate collection (TG/SG) mode, the tip is used to generate a reactant that is detected or reacts at a substrate. For example, the reaction $O + ne \rightarrow R$ occurs at the tip and the reverse reaction occurs at the substrate. In an alternative mode, the substrate is the generator and the tip is the collector (SG/TC) which detects the species formed at the substrate. A frequent mode of operation is the feedback mode where only the tip current is monitored. The tip current is perturbed by the presence of a substrate (located at distance d from the tip) by blockage of the diffusion of solution species to the tip (negative feedback, (a)) and by regeneration of O at the substrate (positive feedback, (b)) as shown in Fig. 1. The tip current–distance curves shown in Fig. 1 are known as negative (a) and positive (b) feedback approach curves. They are described by the following approximate equations

$$I_T(L) = [0.292 + 1.515/L + 0.6553 \exp(-2.4035/L)]^{-1}$$

insulating substrate , (1)

and

$$I_T(L) = 0.68 + 0.78377/L + 0.3315 \exp(-1.0672/L)$$

conducting substrate , (2)

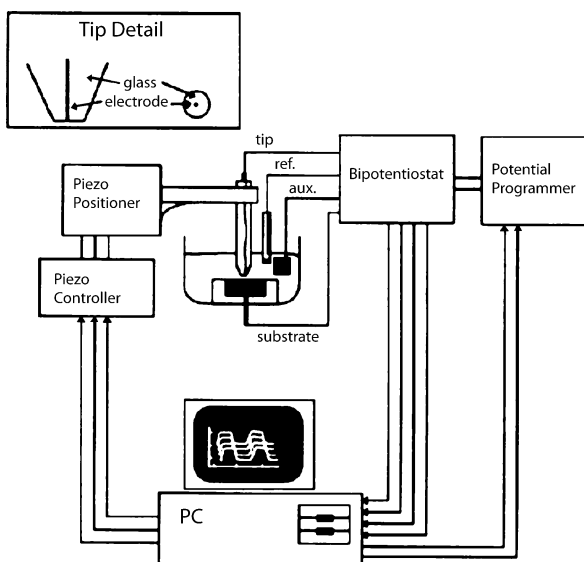

Scanning electrochemical microscopy (SECM) — Figure 2. SECM instrument

where I_T is the ratio of the tip current (i_T) at normalized distance $L = d/a$ and that at an infinite distance ($i_{T,\infty}$) from the underlying substrate, where a is the radius of the UME tip. Thus the tip current ratio decreases below unity as it approaches an insulating substrate such as a piece of glass or inert membrane, and above unity as it approaches a conductive substrate such as a piece of platinum or an electrode. These feedback effects allow investigation of both electrically insulating and conducting surfaces and makes possible imaging of surfaces and the reactions that occur there. The SECM instrument to carry out such investigations is shown in Fig. 2. The movement of the UME tip in the x , y , z directions is usually carried out by drivers based on piezoelectric elements. A bipotentiostat controls the potentials of the UME tip, the substrate, and the common reference and counter electrodes. Generally, all aspects of the SECM instrument and experiment are under computer control. The instrumentation, theory, modes, and initial applications of SECM were developed in the laboratories of Allen J. Bard in the early 1980s. SECM is now used worldwide and applications continue to be developed.

Refs.: [i] Bard AJ, Mirkin MV (eds) (2001) *Scanning electrochemical microscopy*. Marcel Dekker, New York; [ii] Bard AJ, Faulkner LR (2001) *Electrochemical methods*, 2nd edn. Wiley, New York, chaps 5, 16; [iii] Zoski CG (2007) *Handbook of electrochemistry*. Elsevier, Amsterdam, chaps 6, 12

Shearforce positioning (SECM) — The SECM tip is vibrated at its resonance frequency using a piezo pusher, a tuning fork, or a piezo plate mounted on a brass holder. Either by means of a laser focused on the very end of the vibrating tip or using a second piezo plate attached to the SECM tip, the dampening of the vibrating electrode on approach to the sample surface is detected and amplified using a lock-in amplifier. The z-approach curve shows a dampening of the vibration in typical distances up to 300 nm from the sample surface caused by shearforce interaction between the tip and the sample surface. Using a feedback loop a constant dampening of the tip can be maintained and hence a constant tip-to-sample distance can be adjusted throughout scanning. The shearforce-based constant-distance mode of SECM thus allows for the application of nanoelectrodes in SECM.

Refs.: [i] Ludwig M, Kranz C, Schuhmann W, Gaub HE (1995) *Rev Sci Instrum* 66:2857; [ii] James PI, Garfias-Mesias LE, Moyer PJ, Smyrl WH (1998) *J Electrochem Soc* 145:164; [iii] Oyamatsu D, Hirano Y, Kanaya N, Mase Y, Nishizawa M, Matsue T (2003) *Bioelectrochem* 60:115; [iv] Kurulugama RT, Wipf DO, Takacs SA, Pongmayteegul S, Garris PA, Baur JE (2005) *Anal Chem* 77:1111; [v] Yamada H, Ogata M, Koike T (2006) *Langmuir* 22:7923

WSchu

Scanning electron microscopy (SEM) — The scanning electron microscope (SEM) [i] produces high resolution images of a sample surface in high vacuum. The samples must be clean, dry, and electrically conductive. A scanning electron beam with an energy of up to 50 keV is focused to a spot with a diameter in the range of some nm. When the electrons penetrate the sample, they interact with the atoms up to a depth of some μm . Radiation and particles are released such as backscattered electrons (\rightarrow *electron backscatter diffraction (EBSD)*), Auger electrons, elastically scattered electrons, characteristic and bremsstrahlung X-rays, and secondary electrons. Due to their low energy these secondary electrons originate within a few nm from the surface and are detected by photomultipliers to form a two-dimensional image of the surface with a lateral resolution down to 1 nm. The brightness of the signal depends on the number of secondary electrons. Disadvantageous for electrochemical investigations is the high energy of the primary beam which produces a large number of artefacts such as defects and recrystallization processes and the ex-situ vacuum environment. The latter is overcome in part by the environmental scanning electron microscope (ESEM) [ii] which works in low-pressure atmospheres (up to 0.04 bar) and

enables investigation of dirty, wet, or swollen materials such as polymers or biological material.

Refs.: [i] Lyman CE, Newbury DE, Goldstein JI, Williams DB, Romig AD, Armstrong JT, Echlin P, Fiori CF, Joy DC, Lifshin E, Peters K-R (1990) *Scanning electron microscopy, X-ray microanalysis, and analytical electron microscopy*. Plenum Press, New York; Goldstein JI, Newbury DE, Joy DC, Romig AD, Lyman CE, Fiori C, Lifshin E (1992) *Scanning electron microscopy and X-ray microanalysis*. Plenum Press, New York; Goldstein J, Joy DC, Romig AD, Alton D (1986) *Principles of analytical electron microscopy*. Plenum Press, New York; Reimer L (1984) *Scanning electron microscopy: physics of image formation and microanalysis*. Springer, Berlin; Flegler SL, Heckman JW, Klomparens KL (1993) *Scanning and transmission electron microscopy – an introduction*. Oxford University Press, Cary; [ii] Danilatos GD (1988) *Adv Electron Electron Phys* 71:109

MML

Scanning probe microscope — An instrument used for studying surface properties of materials from the atomic to the micron level. All scanning probe microscopes involve a very precise mechanical movement of the probe with respect to the sample (either probe or sample can be moved) by means of piezoelectric translators, while a certain signal is recorded by the probe for every single image point. Two other common components of scanning probe microscopes are a feedback system to keep the signal constant by height readjustment of the probe and an imaging system to convert the single data points into an image. The first of this new generation of microscopes was the scanning tunneling microscope (STM) (\rightarrow *STM in-situ electrochemistry*), which served as a model for its most successful offspring, the atomic force microscope (AFM) (\rightarrow *AFM in-situ electrochemistry*). At this moment, there are several types and modes of using scanning probe microscopes used not only for exploration but also for the atomic-scale control and manipulation of matter [i].

Ref.: [i] Friedbacher G, Fuchs H (1999) *Pure Appl Chem* 71:1337

FG

Scanning probe microscopy (SPM) — A group of techniques comprising the use of different types of microscopies in which a sharp tip is scanned over the sample (or the sample is moved under the probe) providing local information for every single image point. An imaging system converts the data into an image, in some cases with atomic resolution, related to some physical/chemical quantity of the sample surface. The following Table is an overview of SPMs, where main microscopic techniques have been linked to their offspring techniques [i–iii].

Scanning probe microscopy (SPM) — Table

Main technique	Operational modes and related techniques
Scanning tunneling microscopy (STM)	Constant current STM Constant height STM Current imaging tunneling spectroscopy (CITS) Electrochemical scanning tunneling microscopy (ESTM) Scanning noise microscopy (SNM) Scanning tunneling potentiometry (STP) Scanning noise potentiometry (SNP) Alternating current STM (ACSTM) Scanning chemical potential microscopy (SCPM) Scanning optical absorption microscopy (SOAM) Spin polarized STM (SPSTM) Ballistic electron emission microscopy (BEEM) Photon emission STM (PESTM) or Scanning tunneling optical microscopy (STOM) Photon assisted STM (PASTM) or Laser assisted STM (LASTM) Scanning field emission microscopy (SFEM)
Scanning force microscopy (SFM)	Contact mode (CM) or Atomic force microscopy (AFM) DC – Constant height AFM <ul style="list-style-type: none"> – Constant force AFM – Lateral force microscopy (LFM) or Friction force microscopy (FFM) <ul style="list-style-type: none"> • Scanning chemical force microscopy (SCFM) – Conducting atomic force microscopy (C-AFM) <ul style="list-style-type: none"> • Scanning voltage microscopy (SVM) • Scanning spreading resistance microscopy (SSRM) – Contact scanning capacitance microscopy (CM-SCaM) – Contact error AFM AC – Contact EFM <ul style="list-style-type: none"> – Atomic force acoustic microscopy (AFAM) – Young’s modulus microscopy (YMM) or Force modulation microscopy (FMM) – Piezoresponse force microscopy Tapping mode AFM (TM-AFM) or intermittent contact (IC-AFM) <ul style="list-style-type: none"> – Phase imaging AFM – TM error AFM – TM scanning capacitance microscopy (TM-SCaM) Non-contact mode SFM (NC-SFM) Electric force microscopy (EFM) or Scanning maxwell stress microscopy (SMM) <ul style="list-style-type: none"> – scanning surface potential microscopy (SSPM) – scanning kelvin microscopy (SKM) or Kelvin probe microscopy (KPM) – Non-contact scanning capacitance microscopy (NC-SCaM) Magnetic force microscopy (MFM) <ul style="list-style-type: none"> – DC-MFM – AC-MFM Van der Waals force microscopy (VDWFM) or Scanning attractive mode force microscopy (SAFM) Frequency modulation scanning force microscopy (FM-SFM) Dissipation force microscopy
Scanning near-field optical microscopy (SNOM) or near-field scanning optical microscopy (NSOM)	Shear force microscopy (ShFM) Aperture SNOM (ASNOM) <ul style="list-style-type: none"> – Transmission ASNOM (T-ASNOM)

Scanning probe microscopy (SPM) — Table. (continued)

Main technique	Operational modes and related techniques
	<ul style="list-style-type: none"> – Collection ASNOM (C-ASNOM) or reflection mode – Emission ASNOM (E-ASNOM) or luminescence mode Non-aperture SNOM (NA-SNOM) Evanescent Field SNOM (EF-SNOM) or Photon scanning tunneling microscopy (PSTM) or Evanescent field optical microscopy (EFOM) Scanning Near-Field Plasmon Microscopy (SNPM) or Scanning Plasmon Near-Field Microscopy (SPNM) Scanning Near-Field Infrared Microscopy (SNIM) Scanning Near-Field Raman Microscopy (SNRM) Scanning Near-Field Microwave Microscopy (SNMM)
Scanning of near-field acoustic microscopy (SNAM)	
Scanning thermal microscopy (SThM) or Scanning near-field thermal microscopy (SNTThM)	<ul style="list-style-type: none"> – Constant current – Constant temperature Scanning thermal profiler (SThP) Tunneling thermometer (TT)
Scanning electrochemical microscopy (SECM)	<ul style="list-style-type: none"> – Direct mode – Feedback mode – Generation/collection mode Scanning reference electrode technique (SRET) Scanning vibrating electrode technique (SVET) Scanning photoelectrochemical microscopy (SPECM) Scanning electrochemical induced desorption (SECMID)
Scanning micropipette microscopy (SMM)	Scanning micropipette molecule microscopy (SMMM) Scanning ion conductance microscopy (SICM)

Refs.: [i] Friedbacher G, Fuchs H (1999) *Pure Appl Chem* 71:1337;
 [ii] Wiesendanger R (1994) *Scanning probe microscopy and spectroscopy, methods and applications*. Cambridge University Press, Cambridge;
 [iii] Bard AJ, Mirkin MV (2001) *Scanning electrochemical microscopy*. Marcel Dekker, New York

FG

Scanning probe spectroscopy — A group of techniques in which a spatially resolved map of the surface or material properties of a sample is performed with a scanning probe microscope. Spectroscopic and more quantitative information can be obtained by moving the probe to a spot of interest and recording the spectrum of a property regarding some perturbation signal (e.g., the bias voltage) at that specific point as well as by modulating the perturbation signal while scanning [i, ii]. The following Table is a summary of scanning probe spectroscopic techniques.

Refs.: [i] Friedbacher G, Fuchs H (1999) *Pure Appl Chem* 71:1337;
 [ii] Wiesendanger R (1994) *Scanning probe microscopy and spectroscopy, methods and applications*. Cambridge University Press, Cambridge

FG

Scanning probe techniques (SPTs) — Practical methods developed to explore and manipulate matter, many times at atomic scale, by the proximal probe of a → *scanning probe microscope*. SPTs can be used for exploration purposes as → *scanning probe microscopy* (SPM) and → *scanning probe spectroscopy* (SPS) or for control of matter such as nano-lithography, nano-manipulation, or nano-fabrication. The microscopes STM, AFM, and SNOM have served as model systems for a vast number of SPTs differentiated by the type of probe, the nature of the probe-sample interaction, the environment, the operation mode, and the kind of data processing [i].

Ref.: [i] Friedbacher G, Fuchs H (1999) *Pure Appl Chem* 71:1337

FG

SCE → *calomel electrode*

Schenek-Farbaky battery — This was a lead battery containing Pb|PbO negative, Pb|PbO:Pb₃O₄ (1:1) positive electrodes and 30% H₂SO₄ fabricated by István Schenek (1830–1909) and István Farbaky (1837–1928)

Scanning probe spectroscopy — Table

Main technique	Related techniques
Scanning tunneling spectroscopy (STS)	I(z) spectroscopy or Local barrier height spectroscopy (LBHS) I(V) spectroscopy Spin-polarized scanning tunneling spectroscopy (SPSTS) Phonon spectroscopy by inelastic electron tunneling (IET) Photoassisted tunneling spectroscopy (SFES) Tunneling-induced luminescence spectroscopy (TILS) Ballistic electron emission spectroscopy (BEES) Scanning field emission spectroscopy (SFES)
Scanning force spectroscopy (SFS)	Force–distance curves Amplitude–distance curves Phase–distance curves Frequency–distance curves – Kelvin probe spectroscopy – Scanning capacitance spectroscopy Full-resonance spectroscopy (FRS) AFAM resonance spectroscopy (AFAM-RS) Scanning spreading resistance spectroscopy (SSRS)
Scanning near-field optical microscopy (SNOM) or Near-field scanning optical microscopy (NSOM)	Scanning near-field luminescence spectroscopy (SNLS) Scanning near-field raman spectroscopy (SNRS)

in 1882, then professors of the Mining Academy in Selmecbánya, Hungary. These batteries supplied 5 A for 232 hours and were used for the illumination of the Academy, as well as the Opera-house and the Burg-theater in Vienna [i, ii].

Refs.: [i] Schenek I, Farbaký I (1885) *Bányászati Kohászati Lapok* 18:93, 101, 111, 121, 128; [ii] Schenek I (1889) *Ber Ung* 8:1

GI

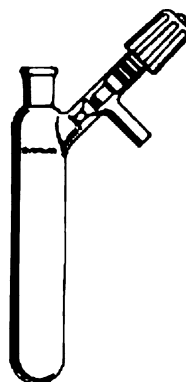

Schlenk apparatus (also called a Schlenk line) — Figure

Schlenk apparatus (also called a Schlenk line) — Specifically designed vacuum transfer line or vacuum sealing technique, named after the German chemist Wilhelm Schlenk (1879–1943). The Schlenk apparatus provides a convenient means of manipulating air and/or water-sensitive materials without the use of an inert atmosphere glove box. Typical operations with Schlenk glassware include additions, chemical reactions, distillations, drying/evaporation, extractions, filtrations, recrystallizations, washing, degassing, and transfers of solids and liquids. For the matter handled, Schlenk technique is commonly used in organic and metal organic chemistry and biochemistry labs.

Schlenk flasks are simply round-bottom or pear-shaped flasks of several sizes; a frequently used form is shown in the Figure. The common feature is a sidearm with a stopcock which permits the user to pull a vacuum on the flask or to fill it with an inert atmosphere.

Normally, the Schlenk line is utilized with vacuum pump technology and -equipment in the technical vacuum range, that is rough (ca. 10^4 – 10^2 Pa) to moderate vacuum (10^2 – 10^{-1} Pa), whereas a ‘(high) vacuum line’ usually has a better vacuum (high vacuum, 10^{-2} to 10^{-5} Pa). There are Schlenk lines with single manifold (only for vacuum) or dual manifold designs (one manifold for vacuum and one for inert, or in some cases, for reactive gases). Schlenk technique is often joined with the use of a cannula, i.e., a long thin metal tube used to transfer air-sensitive liquids or solutions, and/or, the so-

called counterflow technique that provides the possibility to assemble other additional funnels or similar tools to the sensitive Schlenk content, which during the manipulations stays under a slight positive pressure of the inert gas.

Ref.: [i] Tidwell T (2001) *Ang Chem Int Ed* 40:331

MHer

Schönbein, Christian Friedrich



(Reproduced from [v])

(Oct. 18, 1799, Metzingen, Germany – Aug. 29, 1868, Baden-Baden, Germany) Schönbein had an autodidactic education in pharmacy and chemistry, and later studied in Erlangen and Tübingen whilst a director of a factory. However, in 1828 he moved to Basel, and received an honorary doctorate in 1830, becoming a professor in 1835. Schönbein coined the term → *passivity* in relation to the behavior of iron and tin following the action of some chemical compounds, and he is often cited as the discoverer of that phenomenon, although ‘passivity’ had already been described by Keir in 1790 [i]. In 1839 Schönbein described the first → *galvanic cell* based on gases [ii, iii], i.e., oxygen and hydrogen (see also → *Grove*). This was the first → *fuel cell*. In 1839 he discovered the formation of a new gas evolving at the anode during some electrolyses, and he gave the gas the name “ozone” because of its strong odor. He was also the discoverer of gun cotton, i.e., highly nitrated cellulose. See also the biography [iv].

Refs.: [i] Keir J (1790) *Philos Trans* 80:359 (reprinted (1826) Schweigger's *J Chem Phys* 53:151); [ii] Ostwald W (1896) *Elektrochemie. Ihre Geschichte und Lehre*. Veit Comp, Leipzig; (Engl transl: Ostwald W (1980) *Electrochemistry. History and theory*, 2 vols. Amerind Publ, New Delhi); [iii] Schönbein CF (1839) *Philos Mag* 14:43; Nolte P (1999) *Ein Leben für die Chemie. 200 Jahre Christian Friedrich Schönbein. Stadt Metzingen und VHS-Arbeitskreis Stadtgeschichte, Metzingen* (ISBN 3-9802924-6-0); [iv] Reulaux F (ed) (1890) *Das Buch der Erfindungen, Gewerbe und Industrien*, vol. 4. Spamer, Leipzig, p 507

Schottky, Walter



(Courtesy of Institut für Physik, Universität Rostock)

(July 23, 1886, Zürich, Switzerland – Mar. 4, 1976, Pretzfeld, Germany) Schottky was the son of the mathematician Friedrich Schottky (1851–1935). He studied physics in Berlin and was one of the few Ph.D. students of → *Planck* (his thesis concerned the theory of relativity). Until 1915 he worked as an unpaid scientific assistant at the Physical Institute of the Universities of Jena and Berlin, joined then the company Siemens & Halske (→ *Siemens*), and habilitated in 1920 at the University of Würzburg. From 1923–27 he was Professor of Physics at the University of Rostock, and then returned to Siemens & Halske. Schottky was a German physicist whose research in solid-state physics and electronics yielded many effects and devices that now bear his name (Schottky effect, → *Schottky barrier*, → *Schottky contact*, Schottky diode). He performed research in two major areas: vacuum electronics [i] and, starting in 1929, → *semiconductor* electronics. In the field of vacuum electronics, he performed theoretical and experimental studies of the space charge effects of electrons emitted from cathodes in vacuum tubes, and in 1913 he discovered the basic law relating current in a valve to the applied voltage, or what is now known as the “Three-halves law”. In 1915 Schottky invented the screen-grid vacuum tube, and in 1919 he invented the tetrode, the first vacuum tube containing two grids: the basic one and a second grid, called the screen, that prevents electrical oscillations. Schottky theoretically explained the appearance of noise in vacuum valves: the thermal noise originating from the thermal motion of atoms in conductors and the shot noise resulting from random velocity of the emitted electrons [ii]. Schottky studied thermodynamics [iii], structure, and electrical effects in semiconductive materials. He was one of the first to demonstrate the existence of electron → “holes” in the valence-band structure of semiconductors. In 1935 he demonstrated the forma-

FS

tion of structural defects originating from missing ions in the crystal lattice, now known as the Schottky defect. In 1938 he created a theory explaining the rectifying behavior of a metal-semiconductor contact based on a barrier layer at the surface of the contact between two materials. The metal-semiconductor diodes based of this theory are called Schottky barrier diodes [iv].

Refs.: [i] Schottky W (1928) *Physik der Glühelktroden*. Akademische Verlagsgesellschaft, Leipzig; [ii] Johnson JB (1971) *IEEE Spectrum* 8:42; [iii] Schottky W, Ulich H, Wagner C (1929) *Thermodynamik*. Springer, Berlin; [iv] Sharma BL (ed) (1984) *Metal-semiconductor Schottky barrier junctions and their applications*. Springer, New York

EK

Schottky barrier — Energy barrier formed at metal-semiconductor junctions. When a metal is intimately brought into contact with a \rightarrow semiconductor, charge carriers flow through the interface until the matching of the \rightarrow chemical potentials μ_m of the metal and μ_{sc} of the semiconductor is established. As a consequence, a \rightarrow dipole layer is built up at the interface. In the metal, due to the short screening length (\rightarrow Debye length), the excess charge remains localized quite near to the interface. But since in the semiconductor the free charge concentration is significantly lower than in a metal, shielding is much less effective and the space charge extends into the semiconductor.

In the case of an ideal metal semiconductor junction, different situations may arise, depending on the energy difference due to metal \rightarrow work function, semiconductor electron affinity, and the doping of the semiconductor. The formation of the \rightarrow Schottky barrier in case of n -type semiconductor is exemplified in the Figure, for two cases: (a) the metal work function is larger than the semiconductor electron affinity χ_{sc} and; (b) the metal work function $e\Phi_m$ is smaller than the semiconductor electron affinity. In the case depicted in Figure (a), when the metal and semiconductor are contacted, electrons flow from the semiconductor to the metal, depleting a characteristic region in the semiconductor of electrons. This region, denoted depletion region, remains positively charged due to the ionized donors, producing a \rightarrow band bending in the depletion region of the semiconductor, where the electric field is different than zero. In the case depicted in Figure (b), the metal work function is $e\Phi_m$ which is smaller than the semiconductor electron affinity χ_{sc} , so that when metal and semiconductor are connected electrons flow from the metal to the semiconductor, producing a band bending, which is opposite to that observed in Figure (a).

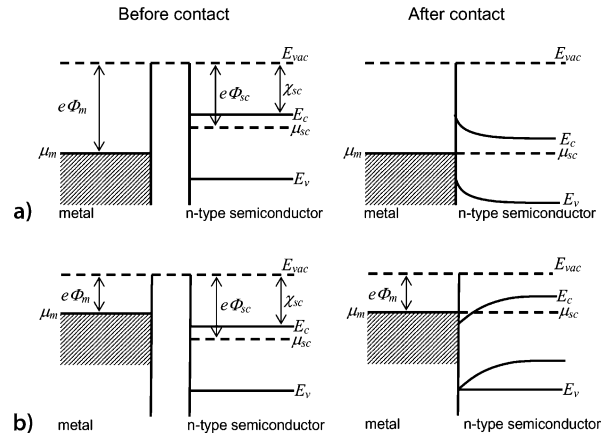

Schottky barrier — Figure

In case of metal junction with a p -type semiconductor, charge flow through the interface also occurs, depending on both, $e\Phi_m$ and χ_{sc} , with a consequent Schottky barrier formation, in a situation analogous to that of the Figure.

Schottky barriers like those shown in Figure (a) present nonsymmetric current versus voltage curves, which in some cases show high rectification and for this reason find practical application in Schottky diodes, which are devices constructed having a \rightarrow Schottky contact. The shape and height of the Schottky barrier, in practical cases, depends on several preparation process parameters, like surface cleanness, surface treatment, presence of surface states, etc. See also \rightarrow flat-band potential.

IH

Schottky contact — Alternative denomination of metal-semiconductor contact presenting a \rightarrow Schottky barrier. Depending on metal \rightarrow work function, semiconductor electron affinity, doping of the semiconductor, conditions of the surface of the semiconductor before contact preparation, and preparation process, Schottky contacts with high rectification can be prepared. Devices incorporating such contacts behave like a diode and for this reason, are also denominated Schottky diodes, whose main features are the capability of high frequency operations and low forward-voltage drop.

Ref.: [i] Ng KK (2002) *Complete guide to semiconductor devices*. Wiley, New York

IH

Schottky defects \rightarrow defects in solids

Schottky diodes → *Schottky contact*

Schottky effect → *Schottky barrier*

Schwabe, Kurt



(Courtesy of Universitätsarchiv der TU Dresden, Fotoarchiv)

(May 29, 1905, Reichenbach, Germany – Dec. 4, 1983, Berlin, Germany) Schwabe studied chemistry from 1924 to 1927 at Technische Universität Dresden, completed his diploma thesis in 1927, his Ph.D. thesis on anodic behavior of metals in 1928, and habilitated in 1933 on the anodic behavior of metals in salt solutions. He was Professor at the Technische Universität Dresden from 1939–1940 and 1949–1970, and from 1949–1983 head of an electrochemical research institute in Meinsberg, Germany. His major contributions concern pH measurements, corrosion, and concentrated electrolyte solutions.

Refs.: [i] Kaden H (2006) *J Solid State Electrochem* 10:676; [ii] Emons HH, Berg H (1986) *Jahrbuch 1983/1984, Sächsische Akademie der Wissenschaften*, p 198

RH

Schweigger, Johann Salomo Christoph



(Apr. 8, 1779, Erlangen, Germany – Sep. 6, 1857, Halle an der Saale, Germany) Schweigger first studied philosophy in Erlangen (Germany). His Ph.D. (1800) thesis concerned the Odes of Homer! Later he turned his attention to natural sciences, and between 1820 and 1857 he served as Professor at the University of Halle an der

Saale (Germany). He founded the “*Jahrbuch für Chemie und Physik*” in 1811, and co-edited it until 1828, when he changed the title to “*Annales de chimie et de physique*“. He published critical papers about Volta’s theory of metal contact in animal electricity. In 1820 he made use of the discovery of → *Ørsted* to develop the first galvanometer (Schweigger’s multiplier). He invented that instrument independent of → *Poggendorff*. Schweigger’s multiplier was later improved by Ørsted, E.H. du Bois-Reymond (1818–1896), and Lord Kelvin (William Thomson, 1824–1907) who, in 1858, put a mirror on the moving part of the galvanometer. That way a great improvement in sensitivity was achieved.

FS

Screen-printed electrodes, SPEs — are → *electrodes* prepared on a substrate of a plastic sheet or foil, or ceramic plate as a single or set of film electrodes by using a screen-printing technique. In screen printing an ink is forced through a screen stencil with a squeegee onto the substrate. Typically, films of an approximately 3-mm diameter graphite disk, semicircle-patterned gold strip, and silver strip serve as the working, auxiliary, and pseudoreference electrode, respectively. Usually, a small drop of a working solution covering all electrodes suffices for determination of a redox analyte. If the working electrodes are modified with dedicated reactants, then SPEs can be applied as ready-to-use, multi-use, or disposable electrode assemblies for detection of desired analytes, for instance, photosynthetic inhibitors like herbicides and heavy metals. SPEs are widely applied for development of electrochemical → *biosensors*. Electrode resolution in screen printing can be as high as 1 micrometer.

WK

Sea cell — This was a → *battery* consisting of a copper and zinc electrode in seawater. See also → *Daniell cell*, → *zinc*, → Zn^{2+}/Zn electrodes, → $Zn^{2+}/Zn(Hg)$ electrodes, → *zinc-air batteries (cell)*, and → *Leclanché cell*.

Ref.: [i] Hauck WP (1883) *Die Galvanischen Batterien, Accumulatoren und Thermosäulen*, 2nd edn. Hartleben’s Verlag, Wien

FS

Seawater — As an → *electrolyte*, the seawater is usually well-aerated and → *buffered* solution of four major → *anions* (Cl^- , SO_4^{2-} , HCO_3^- , and Br^-) and four major → *cations* (Na^+ , Mg^{2+} , Ca^{2+} , and K^+). The total mass of all salts dissolved in 1 kg of seawater is called the → *salinity*. The seawater is conservative with respect to the concentrations of the major ionic components, which means that the ratios of their concentra-

tions are constant at all salinity values. In an average seawater the salinity is 35‰, and the concentrations of major components are as follows: $[\text{Cl}^-] = 0.55865 \text{ mol L}^{-1}$, $[\text{Na}^+] = 0.47912 \text{ mol L}^{-1}$, $[\text{Mg}^{2+}] = 0.05449 \text{ mol L}^{-1}$, $[\text{SO}_4^{2-}] = 0.02890 \text{ mol L}^{-1}$, $[\text{Ca}^{2+}] = 0.01051 \text{ mol L}^{-1}$, $[\text{K}^+] = 0.01045 \text{ mol L}^{-1}$, $[\text{HCO}_3^-] = 2.38 \text{ mmol L}^{-1}$, $[\text{Br}^-] = 0.86 \text{ mmol L}^{-1}$, $[\text{B}(\text{OH})_3] = 0.43 \text{ mmol L}^{-1}$, $[\text{F}^-] = 0.06 \text{ mmol L}^{-1}$, and $[\text{Si}^{2+}] = 0.09 \text{ mmol L}^{-1}$. The \rightarrow *ionic strength* and the relative \rightarrow *permittivity* of the average seawater at 20 °C are $I = 0.714 \text{ mol L}^{-1}$ and $\epsilon_{r,\text{SW}} = 71.61$, respectively. The pH of the seawater is defined by the dissolved carbonates and the dissociation of the dissolved CO_2 . The average value of pH is 8.2 ± 0.1 . The concentration of dissolved \rightarrow *oxygen* in the aerated seawater is about 0.5 mmol L^{-1} . If the oxygen is removed by purging with nitrogen gas, the pH of seawater may increase to about 8.6 because of the loss of CO_2 . This can be avoided by adding CO_2 to the purging gas. Concentrations of heavy metal ions in seawater are smaller than $5 \times 10^{-8} \text{ mol L}^{-1}$, and only twelve elements appear in concentrations between 10^{-4} and $10^{-8} \text{ mol L}^{-1}$. However, the concentrations of natural \rightarrow *surface-active substances* in the seawater may be significant.

Ref.: [i] Whitfield M, Turner DR (1981) *Seawater as an electrochemical medium*. In: Whitfield M, Jagner D (eds) *Marine electrochemistry*. Wiley, Chichester, p 3

SKL

Sealed battery — Hermetically sealed \rightarrow *battery*. While for some batteries, like lithium and lithium ion cells (\rightarrow *lithium batteries*), the term is redundant, as all the nonaqueous solution-based cells are hermetically sealed, it is not so for \rightarrow *lead-acid* and \rightarrow *nickel-cadmium batteries*. The later batteries may evolve gas (mainly oxygen and hydrogen) during charge, discharge, overdischarge, or overcharge, and thus have to be vented. The sealed lead-acid and nickel-cadmium batteries are later developments, that incorporate an internal mechanism for hydrogen recombination with oxygen during charge, thus reducing dramatically the danger of pressure buildup and water loss. The most common sealed lead-acid cells are the “absorbed electrolyte” and the “gelled electrolyte” types. In sealed lead-acid batteries reduced gas evolution is sometimes accomplished also by using calcium-lead alloys for the grid. For safety purposes these systems always contain a pressure relief valve that regulates the internal pressure and water loss. Similar technology is utilized also in sealed nickel-metal-hydride batteries, a relative new-comer in the market. Sealed batteries have also the advantage of being maintenance-free, not needing water taping, and

they pose less danger of spoilage of their corrosive electrolytes.

Refs.: [i] Crompton TR (2000) *Battery reference book*, 3rd edn. Newnes, Oxford, pp 1/61, 4/4–4/7; [ii] Hammel RO, Salkind AJ, Linden D (1994) *Sealed lead-acid batteries*. In: Linden D (1994) *Handbook of batteries*, 2nd edn. McGraw-Hill, New York, pp 25.29–25.30; [iii] Linden D (1994) *Sealed nickel-metal hydride batteries*. In: Linden D (1994) *Handbook of batteries*, 2nd edn. McGraw-Hill, New York, pp 33.1–33.29; [iii] Carcone JA (1994) *Sealed nickel-cadmium batteries*. In: Linden D (1994) *Handbook of batteries*, 2nd edn. McGraw-Hill, New York, pp 28.1–33.35

YG

SECM \rightarrow *scanning electrochemical microscopy*

Secondary current distribution \rightarrow *current density*

Secondary battery \rightarrow *battery*

Second harmonic — Any nonlinear oscillating system produces higher harmonic oscillations. The second harmonic is the response having twice the frequency of the basic oscillation. The \rightarrow *current* response of a faradaic electrode reaction (\rightarrow *faradaic reaction*) to perturbations of the \rightarrow *electrode* \rightarrow *potential* is generally nonlinear, and thus higher harmonic oscillations of the \rightarrow *alternating current* (AC) are produced in \rightarrow *AC voltammetry*. Since the \rightarrow *capacitive current* is a much more linear function of the electrode potential, the capacitive contribution to higher harmonic currents are rather small which allows a desirable discrimination of these currents in electro-analytical applications.

Ref.: [i] Bond AM (1980) *Modern polarographic methods in analytical chemistry*. Marcel Dekker, New York, pp 356

FS

Second harmonic generation spectroscopy \rightarrow *spectroscopy*

Secondary battery \rightarrow *battery*, \rightarrow *galvanic cell*

Secondary cell \rightarrow *battery*, \rightarrow *galvanic cell*

Secondary ion mass spectrometry \rightarrow *surface analytical methods*

Secondary standard — (*in titrimetry*) A chemically stable compound whose active agent contents have been established by its \rightarrow *titration* with a primary standard to be subsequently used as \rightarrow *titrant* [i].

Ref.: [i] Mendham J, Denney R, Barnes J, Thomas M (2000) *Vogel's quantitative chemical analysis*. Prentice Hall, New Jersey

FG

Sedimentation potential — (also called electrophoretic or Dorn potential) Potential difference established during sedimentation (caused, e.g., by gravitation or centrifugation) of small charged particles (suspended in solution: dispersion of solid particles or emulsion of immiscible liquid droplets).

Refs.: [i] McNaught AD, Wilkinson A (1997) *IUPAC compendium of chemical technology*. Blackwell Science, Boston; [ii] Newman J, Thomas-Alyea KE (2004) *Electrochemical systems*, 3rd edn. Wiley Interscience, Hoboken, pp 256

RH

Seebeck effect — is the \rightarrow potential difference that results when the joins of two different metals are at different temperatures and induces a movement of charge through the conductors. The Seebeck effect is the opposite of the Peltier effect (see \rightarrow Peltier heat).

Refs.: [i] de Groot SR, Mazur P (1984) *Non-equilibrium thermodynamics*. Dover, New York; [ii] Newman J, Thomas-Alyea KE (2004) *Electrochemical systems*, 3rd edn. Wiley Interscience, Hoboken, pp 317

MBS

Selectivity coefficient — $K_{A,B}^{\text{pot}}$ is a measure of the contribution of an interfering ion B to the potential of an \rightarrow ion-selective electrode in a mixed solution containing the primary ion A and an interfering ion B. It is defined by the modified \rightarrow Nikolskij–Eisenman equation. The smaller the value of $K_{A,B}^{\text{pot}}$, the better the selectivity of the electrode with respect to the primary ion A. Selectivity coefficients can be evaluated by measuring the response of an ion-selective electrode in mixed solutions of A and B (fixed interference method) or in separate solutions of A and B (separate solution method).

Refs.: [i] Buck RP, Lindner E (1994) *Pure Appl Chem* 66:2527; [ii] Su YS (1993) *Characteristics of ion-selective electrodes*. In: Yu TR, Ji GL (eds) *Electrochemical methods in soil and water research*. Pergamon Press, Oxford, pp 126–131; [iii] Moody GJ, Thomas JDR (1971) *Selective ion-sensitive electrodes*. Mellow Publishing, Watford

HK

Self-assembled monolayers (SAM) — Molecular monolayers formed at \rightarrow interfaces (solid|solution, solution|gas, or solid|gas) by self-assembly, i.e., assembly without any guidance or management from an outside source like a Langmuir trough. The phenomenon of self-assembly, which includes also such systems as lipid bilayer membranes, \rightarrow micelles and \rightarrow liposomes in solution, liquid crystals, and a variety of biological systems, belongs to a larger group of self-organization phenomena occurring in nature. Self-assembled monolayers are formed spontaneously.

The decrease in \rightarrow entropy associated with increased order of molecules forming the film is compensated for by intermolecular attractive forces (such as \rightarrow van der Waals forces, electrostatic, \rightarrow London forces) or increased entropy of surrounding medium in open systems. The molecules forming self-assembled monolayers usually are composed of a hydrophilic (ionic or neutral) head, such as the thiol, phosphate, or sulfate group, and a hydrophobic tail, e.g., a hydrocarbon chain. For instance, hexadecane thiol molecules can form a dense self-assembled monolayer on metals with the S head group attached directly to the metal surface and the tail tilted at an angle typically 0°–40° from the normal to the electrode surface. In this case, the well-ordered parallel hexadecyl chains form a layer of low dielectric constant medium which causes a decrease of electrode \rightarrow capacitance and \rightarrow charge transfer rate for \rightarrow redox reactions. The degree of order in thiolate films increases with carbon chain length, while the electric conductance decreases with it. The contributions to the film conductance are from direct electron tunneling, conductance through pin-holes, and \rightarrow electron hopping between localized states. Hydrophobic redox species have a propensity to dissolve in the hydrocarbon chain layer. By inserting ion channel polypeptides (e.g., gramicidin) or conformationally modifiable compounds (e.g., glutathione), the ion permeability of self-assembled monolayers can be controlled.

The self-assembled monolayers can be functionalized by adding various functional groups ($-\text{NH}_2$, $-\text{COOH}$, etc.) at the tail end for further binding or sensory applications. For attachment of large biomolecules to a self-assembled monolayer, spacers are often used, resulting in a mixed self-assembled monolayer (e.g., mixed layer composed of short- and long-chain thiols).

The self-assembly of monolayers is an important manufacturing technique to construct desired structures by templated deposition of metals and semiconductors, for a design of multifunctional nanoelectronic devices, synthesis of highly sensitive piezoelectrochemical sensors for toxins (PCB), herbicides (e.g., atriazine), and pesticides, heavy metal sensors, electronic noses, single-electron transistors, quantum dot memories, etc. The self-assembled monolayers can be printed using dip-pen nanolithography or microcontact printing to form desired patterns for further processing.

Refs.: [i] Zhong CJ, Porter MD (1997) *J Electroanal Chem* 425:147; [ii] Hepel M, Tewksbury E (2003) *J Electroanal Chem* 552:291; [iii] Hepel M (2001) *J Electroanal Chem* 509:90

MHep

Self-contained hydrogen electrode (SCHE) — is a → *hydrogen electrode* using a → *platinized platinum* (subentry of → *electrode materials*) (wire) electrode partially immersed in an electrolyte solution. The emerged (upper) part of this wire is in contact with a hermetically sealed H₂ gas bubble above the electrolyte. That part of the Pt wire is wetted with the meniscus and a thin film of the electrolyte. This film allows dissolved H₂ to diffuse faster to the electrode surface than the boundary layer of electrolyte otherwise generated by H₂ bubbles dispersed in a bulk electrolyte. SCHE avoids both the inconveniences of the conventional H₂ electrode and the shortcomings of the → *dynamic hydrogen electrode*. It does not require an external supply of H₂ or a source of electrical power. SCHE is a reversible H₂ electrode that maintains its potential like a conventional H₂ electrode. Therefore, it is used as a → *reference electrode*. SCHE is portable and easy to miniaturize. It is prepared, e.g., by filling the glass capillary with electrolyte under reduced pressure, followed by galvanostatic generation of H₂ on the platinized Pt wire cathode. Any inert → *auxiliary electrode* can be used as the O₂-evolving anode, which is then removed after use. The H₂ formed on the Pt wire displaces electrolyte at the top end of the glass capillary. Electrolysis is continued until 1/4 to 3/4 of the Pt wire is surrounded by H₂ gas. A current of 0.04 A produces a 2-cm-long H₂ bubble in a glass tube of 4 mm inner diameter during ca. 1 min.

Ref.: [i] Will FG (1986) *J Electrochem Soc* 133:454

WK

Self-diffusion — Particles (atoms, molecules, ions) in liquids or solids vibrate about their temporary equilibrium positions until they gain, due to fluctuations, an energy sufficient to overcome the energy barrier separating two adjacent equilibrium positions and move to this adjacent position. This phenomenon is the self-diffusion [i]. Self-diffusion normally cannot be investigated experimentally, since it is impossible to distinguish a given atom or molecule from the others while keeping its properties completely unchanged in order to follow its movement caused by the fluctuations. However, if a very small portion of the atoms is replaced by an isotope and measuring the tracer diffusion, in a relatively good approximation, reliable data can be obtained for the self-diffusion coefficient [ii–iv]. Such information helps to understand the structure of the liquid or solid material and the mechanism of the → *transport process*. The self-diffusion coefficient of water was found to be $2.57 \times 10^{-5} \text{ cm}^2 \text{ s}^{-1}$ at 25 °C [v]. See also → *Einstein*, → *diffusion*.

Refs.: [i] Erdey-Grúz T (1974) *Transport phenomena in aqueous solutions*, Adam Hilger, London, p 390; [ii] Haissinsky M (1957) *La chimie nucléaire et ses applications*. Masson, Paris, p 557; [iii] Hevesy G (1938) *Trans Faraday Soc* 34:841; [iv] Groh J, Hevesy G (1921) *Ann Physik* 65:216; [v] Wang JH (1954) *J Phys Chem* 58:686

GI

Self-discharge — Spontaneous decrease in the amount of charge stored in a cell or a → *battery*. Both secondary and primary batteries suffer from self- → *discharging*. The self- → *discharge rate* is dependent primarily on the chemistry of the cell. Some cells, such as the → *Leclanché* and the → *lead-acid cell* are notorious to suffer from relatively high self-discharge rates, while alkaline MnO₂ (→ *manganese*) and some primary → *lithium batteries* are characterized by low self-discharge ones. The rate of self-discharge of any particular cell is dependent on the number of variables, the most important ones are the storage temperature and state of charge. The source for self-discharge is specific for the specific cell chemistry. It usually involves unwanted reactions between the electrolyte, or specific components in the electrolyte, with the cathode or the anode. For primary batteries self-discharge is always detrimental and irreversible, while in rechargeable batteries, in some cases the decrease in the cell capacity due to self-discharge is reversible, and the cell regains its rated capacity after charging.

Refs.: [i] Crompton TR (2000) *Battery reference book*, 3rd edn. Newnes, Oxford; [ii] Linden D (1994) *Handbook of batteries*, 2nd edn. McGraw-Hill; [iii] Gates Energy Products (1998) *Rechargeable batteries applications handbook (EDN Series for Design Engineers)*. Elsevier New York, pp 105–109

YG

SEM → *scanning electron microscopy*

Semiconductive/resistive sensors → *gas sensors*

Semiconductor — In an insulator at a temperature $T = 0$ all bands are either completely empty or completely filled, whereas in a metal, at least one band is partially filled. Insulators can be characterized by the band gap (energy gap) between the top of the → *valence band* (highest filled band) and the bottom of the → *conduction band* (lowest empty band). At $T \neq 0$ there is a non-vanishing probability that some electrons will be thermally excited from the valence bands into the conduction bands, leaving behind unoccupied states in the valence bands, which are called → *holes*. These electrons and holes are then capable of participating in electronic conduction. Solids that are insulators at $T = 0$, but

whose band gaps present values that allow thermal excitation leading to observable conductivity at temperatures below the melting point are called semiconductors. Examples of semiconductors are Si, Ge (group IV semiconductors); the compound semiconductors GaAs, InSb, GaP (called III–V semiconductors); and CdTe, ZnSe (called II–VI semiconductors).

If a semiconductor is so pure that impurities contribute negligibly to \rightarrow charge carrier densities in the conduction and valence bands, it is called an intrinsic semiconductor and the intrinsic charge-carrier density dependence on temperature is given by $n_i(T) \propto T^{\frac{3}{2}} \exp\left(-\frac{E_g}{2k_B T}\right)$, where E_g is the band-gap energy and k_B is the \rightarrow Boltzmann constant.

Impurities can be intentionally introduced in semiconductors, characterizing the doping of the semiconductor, in order to change the electrical conductivity. The doping impurities are called donors if they supply additional electrons to the conduction band and acceptors if they supply additional holes to the valence band, i.e., accept electrons of the valence band. Semiconductors doped with donors are called n -type semiconductors and those doped with acceptors are called p -type semiconductors, since charge transport then occurs preponderantly through electrons and holes, denominated majority charge carriers, respectively. In the simplest cases, donors and acceptors are substitutional impurities that have a higher and lower chemical valence, respectively, than the substituted element.

The magnitude of the band gap determines the free charge-carrier density in semiconductors at temperatures $T \neq 0$, as well its optical properties in the visible and/or adjacent parts of the spectrum. In semiconductors the optical absorption is characterized by a sharp growth caused by interband optical transitions in which the photon energy is used to create electron-hole pairs. Interband transitions are subdivided into direct and indirect. The band gap is called direct, implying so-called direct transitions, if the maximum of the valence band coincides with the minimum of the conduction band in the electron quasimomentum coordinate. If valence band maximum and conduction band minimum occur at different quasimomentum coordinates, the semiconductor presents an indirect band gap, implying so-called indirect transitions. In direct band-gap transitions, the absorption threshold occurs when the photon energy equals the band-gap energy E_g . The absorption coefficient for direct interband transitions in nondegenerate semiconductors is given by the expression $\alpha = A_d (hf - E_g)^{\frac{1}{2}}$, where A_d is indepen-

dent of $(hf - E_g)$, h is the \rightarrow Planck constant, and f is the frequency, so that a plot of α^2 versus hf gives a straight line whose extrapolation intersects the hf axis at $hf = E_g$. In case of indirect band-gap transitions the laws of conservation exclude the possibility of the absorption of photons with energies equal to E_g without modification of the quasimomentum of the electron, and transitions are only possible for energies larger than E_g , depending on the particular dispersion relation (dependence of the electron energy on quasimomentum). The necessary change in quasimomentum, however, can be provided by phonons or lattice defects. For indirect optical interband transition, quantum-mechanical calculations lead to $\alpha \propto \left[e^{\frac{\delta}{k_B T}} - 1 \right]^{-1} (hf + \delta - E_g)^2 + \left\{ 1 + \left[e^{\frac{\delta}{k_B T}} - 1 \right]^{-1} \right\} (hf - \delta - E_g)^2$. The two terms of the expression of α correspond to optical absorption with phonon absorption (first term) and optical absorption with phonon emission (second term). A plot of $\alpha^{1/2}$ versus hf gives two straight lines, whose extrapolations intersect the hf axis at hf_1 and hf_2 ($f_1 < f_2$) and $E_g = \frac{hf_1 + hf_2}{2}$ and $\delta = \frac{hf_2 - hf_1}{2}$.

In case of semiconductor electrodes the properties of the interface between a semiconductor and a solution are similar to those of the interface between a semiconductor and a metal (see \rightarrow Schottky barrier). There are, however, some particularities. At this interface the semiconductor presents electronic conduction whereas the liquid presents ionic conduction. In the semiconductor, the density of electronic states at the chemical potential can be equal to zero, imposing constraints to charge transport through the interface, but even in this case it is still the chemical potential that determines the magnitude of the equilibrium current across the interface, which is achieved by electron-ion exchange. The equilibrium signifies the absence of any net currents through the interface.

The \rightarrow electrode potential, with respect to a given reference is determined by the \rightarrow electrochemical potentials of the \rightarrow redox couple in solution. In case of doped semiconductor electrodes, the introduced impurities determine the semiconductor electrical properties, but have no influence on the equilibrium electrode potential, despite influencing the semiconductor \rightarrow work function.

The attainment of equilibrium between the semiconductor and solution, however, is somewhat hindered. Many semiconductor electrodes behave over a broad range of potentials as ideally \rightarrow polarizable electrodes.

Depending on potential, the presence of the depletion layer in the semiconductor (see also \rightarrow Schottky barrier)

and the consequent electric field can impede majority charge carriers to achieve the electrode/solution interface and participate in the charge transport across the interface. If the semiconductor is under illumination with photons having energy larger than the band gap energy, these create electron-hole pairs and the minority charge carriers are favored by the depletion layer electric field, not suffering hindrance. These minority charge carriers can be transported through the interface contributing to photoassisted electrode reactions.

Surface atoms have fewer neighbors than bulk atoms and part of the chemical bonds that constitute the bulk crystal are broken at the surface, leading to an electronic structure different than in the bulk. The main common characteristic of IV, III-V, and II-VI semiconductors is the tetrahedral atomic bonding resulting from the covalent sp^3 hybrids. The sp^3 hybridization leads to the formation of strongly directional bond lobes that appear as dangling bond orbitals at the surface, which originate electronic states inside the band gap of the semiconductor. The density of surface states depends on the crystalline orientation of the surface, since the density of atoms and dangling bonds vary also with surface orientation. These surface electron states present on the pure surfaces of semiconductor crystals are usually called intrinsic states. In real surfaces and those in contact with electrolyte solutions the presence of adsorbed atoms and crystal defects result in different surface electron energy levels, called extrinsic, which play an important role in \rightarrow adsorption and \rightarrow catalysis processes. These surface states may produce strong deviations from ideal Schottky barrier behavior.

Refs.: [i] Ashcroft W, Mermin ND (1976) *Solid state physics*. Saunders College, Philadelphia; [ii] Pleskov YuV, Gurevich YuYa (1986) *Semiconductor photoelectrochemistry*. Consultants Bureau, New York; [iii] Bube RH (1992) *Photoelectronic properties of semiconductors*. Cambridge University Press, Cambridge; [iv] Lüth H (1995) *Surfaces and interfaces of solid materials*. Springer, Berlin

IH

Semiconductor electrode \rightarrow photoelectrochemistry, \rightarrow semiconductor

Semidifferentiation — This operation “undoes” \rightarrow semiintegration. One definition is $\frac{d^{1/2}}{dt^{1/2}} f(t) = \frac{d}{dt} \left[\frac{d^{-1/2}}{dt^{-1/2}} f(t) \right]$ where the bracketed quantity is the semiintegral of $f(t)$. In voltammetry, the \rightarrow faradaic current is proportional to the semiderivative of the concentration excursion of reactant and product at the electrode. Semidifferentiation of a reversible linear-scan voltammogram (\rightarrow linear-scan

voltammetry) produces a symmetrically peaked curve whose height and area are proportional to the bulk analyte concentration and independent of sweep rate, aiding resolution and quantification.

Ref.: [i] O'Neill RD, Fillenz M, Albery WJ, Goddard NJ (1983) *Neuroscience* 9:87

KBO

Semiintegration — Let $f(t)$ be some time-dependent property, interest in which commences at time $t = 0$. The indefinite integral of this function is a well-known quantity, for which $\frac{d^{-1}}{dt^{-1}} f(t)$ is an informative but unfamiliar symbol: $\frac{d^{-1}}{dt^{-1}} f(t) = \int_0^t f(\tau) d\tau$. Less well known is that differentiation and integration are just the $\nu = \pm 1$ instances of a continuum of operations that can be performed on $f(t)$ and which result in quantities that can be denoted $\frac{d^\nu}{dt^\nu} f(t)$. Semiintegration and \rightarrow semidifferentiation are the $\nu = -\frac{1}{2}$ and $\nu = +\frac{1}{2}$ cases. One definition of semiintegration is $\frac{d^{-1/2}}{dt^{-1/2}} f(t) = \frac{1}{\sqrt{\pi}} \int_0^t \frac{f(\tau)}{\sqrt{t-\tau}} d\tau$. Examples are $\frac{d^{-1/2}}{dt^{-1/2}} t^n = \frac{2^{2n+1} (n!)^2}{\sqrt{\pi} (2n+1)!} t^{n+\frac{1}{2}}$, $n = 0, 1, 2, \dots$

If an electroreactant reaches a working electrode by semiinfinite planar diffusion, then the semiintegral of the current is related by the simple equation $\frac{d^{-1/2}}{dt^{-1/2}} I(t) = nAF\sqrt{D} [c^b - c^s(t)]$ to the difference between the bulk concentration c^b of the reactant and its concentration $c^s(t)$ at the electrode surface. Other symbols have their standard meanings. See also \rightarrow convolution.

Refs.: [i] Oldham KB, Spanier J (2006) *The fractional calculus*. Dover, New York; [ii] Oldham KB (1997) *J Electroanal Chem* 430:3

KBO

Semilogarithmic plot — This is a method for analyzing DC \rightarrow polarograms (i.e., recorded with a \rightarrow dropping mercury electrode), convoluted responses (\rightarrow convolution) in \rightarrow cyclic voltammetry, and \rightarrow voltammograms recorded under \rightarrow steady-state conditions on a \rightarrow rotating disk electrode and \rightarrow microelectrodes. The responses of a simple, fast, and \rightarrow reversible electrode reaction $Ox + n e^- \rightleftharpoons Red$ in these techniques can be described by a common equation: $I = I_L / (1 + \exp(\varphi_{1/2}))$, where I is a \rightarrow current, I_L is the \rightarrow limiting current, which is caused by the mass transfer polarization of the \rightarrow working electrode, $\varphi_{1/2} = nF(E - E_{1/2})/RT$ is a dimensionless \rightarrow potential difference, n is a number of electrons in the electrode reaction, E is the electrode potential, and $E_{1/2}$ is the \rightarrow half-wave potential which depends on the \rightarrow formal potential $E_c^{\ominus'}$ of the electrode reaction

in the chosen \rightarrow electrolyte, the \rightarrow diffusion coefficients of the reactant and product, and the applied technique: $E_{1/2} = E_c^{\ominus'} + (RT/2nF) \ln(D_{\text{red}}/D_{\text{ox}})$ in polarography, and $E_{1/2} = E_c^{\ominus'} + (RT/nF) \ln(D_{\text{red}}/D_{\text{ox}})$ in the steady-state voltammetry. It is assumed that only the reactant Ox is initially present in the bulk of solution. It is obvious that the logarithm of the ratio $(I_L - I)/I$ is a linear function of the electrode potential:

$$\log [(I_L - I)/I] = 0.4342 \times nFE/RT - 0.4342 \times nFE_{1/2}/RT.$$

The slope of this straight line is $16.91 \times n \text{ V}^{-1}$ at 25°C . However, it is more common to use the inverse function: $E = E_{1/2} + 2.303 \times (RT/nF) \log [(I_L - I)/I]$, with the slope $0.059/n \text{ V}$. Both functions are called the logarithmic analysis of DC polarogram. They both cross the potential axis at the half-wave potential, which corresponds to $I = I_L/2$. The main characteristic of fast and reversible electrode reactions is that the half-wave potential is independent of the drop life-time in DC polarography, or the rotation rate of the rotating disk electrode, or the radius of microelectrode. If this condition is satisfied, the slope of the logarithmic analysis indicates the number of electrons in the electrode reaction.

The current–potential relationship of the totally \rightarrow irreversible electrode reaction $\text{Ox} + ne^- \rightarrow \text{Red}$ in the techniques mentioned above is: $I = I_L \kappa \exp(-\alpha\phi) / (1 + \kappa \exp(-\alpha\phi))$, where $\kappa = 0.886 \times k_s \sqrt{t/D}$ in polarography and $\kappa = k_s \delta/D$ in the steady-state voltammetry, α is a \rightarrow transfer coefficient, k_s is \rightarrow standard rate constant, t is a drop life-time, δ is a \rightarrow diffusion layer thickness, and $\phi = nF(E - E_c^{\ominus'})/RT$. The logarithmic analysis of this wave is also a straight line: $E = E_c^{\ominus'} + 2.303 \times (RT/\alpha nF) \log \kappa + 2.303 \times (RT/\alpha nF) \log [(I_L - I)/I]$. The slope of this line is $0.059/\alpha n \text{ V}$. It can be used for the determination of transfer coefficients, if the number of electrons is known. The half-wave potential depends on the drop life-time, or the rotation rate, or the microelectrode radius, and this relationship can be used for the determination of the standard rate constant, if the formal potential is known.

In the general case, the logarithmic analysis of the wave is a curve with two asymptotes. For the reduction, the slope of the asymptote at higher potential is $0.059/n \text{ V}$, while the slope of the asymptote at lower potentials is $0.059/\alpha n \text{ V}$. The half-wave potential depends on the drop life-time, or the diffusion layer thickness. The electrode reactions with these characteristics are called \rightarrow quasireversible.

Ref.: [i] Heyrovský J, Kůta J (1966) *Principles of polarography*. Academic Press, New York

ŠKL

Sensors — Devices that perceive changes in physical properties of the environment and turn these into a signal which can be measured. Chemical sensors (including also \rightarrow biosensors) are devices that transform chemical information ranging from concentration of a specific sample component to total composition analysis, into an analytically useful signal. Commonly, chemical sensors contain a receptor which responds to chemical composition of the sample, and a transducer which transforms the property changes of the receptor into a measurable electrical signal. Important groups are optical, electrochemical, mass-sensitive, and thermometric sensors. Electrochemical sensors include \rightarrow amperometric, potentiometric (\rightarrow potentiometry), and conductometric (\rightarrow conductometry) sensors. Prominent examples of electrochemical sensors: the \rightarrow lambda probe for determining oxygen in exhaust gases of motor cars; the \rightarrow ion-sensitive field effect transistor, and amperometric \rightarrow glucose sensors.

Refs.: [i] IUPAC (1991) *Pure Appl Chem* 63:1247; [ii] IUPAC (1999) *Pure Appl Chem* 71:2333; [iii] Gründler P (2007) *Chemical Sensors*. Springer, Berlin; [iv] Janata J (1989) *Principles of chemical sensors*. Plenum, New York

PG

Separator (in batteries and capacitors) — Technical term for the \rightarrow diaphragm in \rightarrow batteries and \rightarrow capacitors.

FS

Series circuit \rightarrow circuit

SERS \rightarrow surface enhanced Raman scattering

Ševčík, Augustin — (1926–2006) Research student of \rightarrow Heyrovský, J. In his dissertation he derived an equation for diffusion-controlled voltammetric curves [i], independently of \rightarrow Randles. See also \rightarrow Randles–Ševčík equation.

Ref.: [i] Ševčík A (1948) *Coll Czech Chem Commun* 13:349

MHey

Severinghaus electrode \rightarrow carbon dioxide sensor

SEXAFS — Surface-extended X-ray absorption fine structure (spectroscopy), a modified form of \rightarrow EXAFS adopted to the needs of surface and interfacial science; for details see \rightarrow EXAFS.

Refs.: [i] Holze R (2008) *Surface and interface analysis: an electrochemists toolbox*. Springer, Berlin; [ii] Agarwal BK (1991) *X-ray spectroscopy*. Springer, Berlin; [iii] Tsuji K, Injuk J, Van Grieken R (eds) (2004) *X-ray spectrometry: recent technological advances*. Wiley, Chichester

RH

Shearforce positioning → *scanning electrochemical microscopy*

Shielding — refers to the fastening of electrical equipment to earth (here: → *grounding* or → *earthing*). In a broader meaning, shielding or synonymously ‘screening’, includes all measures to prevent the pick-up or transmission of stray electrical signals, or lightning strikes and electrostatic discharges (ESD), but also to eliminate electric fields within a volume and therefore to avoid noise in communication engineering devices. In this context, a shield is a housing, sheath, screen, or cover that substantially reduces the inductive coupling of electric, magnetic, or electromagnetic fields into or out of circuits or transmission lines. The protection of sensitive electrical equipment from external radiofrequency (RF) electromagnetic radiation is usually referred to as ‘RF shielding’. The shielding is achieved using a conductive material as a barrier. Typical materials include sheet metal, metal mesh, ionized gas, plasma, and aluminum foil. Shielding can reduce the coupling of radio waves, visible light, electromagnetic and electrostatic fields. The amount of reduction depends upon the material used, the method of connection of the shield, and the frequency of the fields of interest. Examples include grids in the front of microwave ovens, or installations as the outer metal wire mesh surrounding and screening the signal-carrying inner wire of coaxial cable links. The shielding in the latter impedes the escape of any signal from the core conductor, and also signals from being added to the core conductor. Some cables have two separate concentric screens, one connected at both ends, the other at one end only, to maximize shielding of both electromagnetic and electrostatic fields. Most well-known is the → *Faraday box*, a grounded wire mesh cage for electrostatic screening to prevent the passage of electromagnetic waves, either containing them in or excluding them from its interior volume, which was first built in 1836 by → *Faraday*. To guarantee an effective enclosure, any holes in the box or mesh must be significantly smaller than the wavelength of the radiation.

The term is also used in electrochemical systems where one electrode carries out the same reaction at

a neighboring electrode and so shields that electrode from some of the reactant, as in the → *rotating ring-disk electrode* or → *scanning electrochemical microscopy*.

Ref.: [i] Gibilisco S (ed) (2001) *The illustrated dictionary of electronics*, 8th edn. McGraw-Hill, New York

MHer

Shelf life — A period of time in which a → *battery* can be stored under specified conditions before it fails to deliver minimum specified performance of energy and → *power*. The shelf life of batteries, primary and secondary, is dependent on the type of battery, the storage temperature and humidity, and on the state of charge. The main sources that limit batteries shelf life is self → *discharging*, → *corrosion*, and dehydration.

Refs.: [i] Crompton TR (2000) *Battery reference book*, 3rd edn. Newnes, Oxford, pp 2/5, 2/10, 9/12, 31/16–31/17; [ii] Dell RM, Rand DAJ (2001) *Understanding batteries*. The Royal Society of Chemistry, Cambridge, p 29; [iii] Kiehne HA (2003) *Battery technology handbook*. Marcel Dekker, New York, pp 142, 241, 406

YG

Sheltered electrode → *retarded electrode*

Shikata, Masuzo — (Aug. 10, 1895, Tokyo, Japan – May 8, 1964, Kyoto, Japan) In 1920 Shikata graduated from the Department of Agricultural Chemistry of the Imperial University of Tokyo. In 1922 he went to Europe, and the next year joined → *Heyrovský, J.* in Prague, Czechoslovakia. In 1924 Heyrovský and Shikata [i] developed the first → *polarograph* – the first automatic instrument to record current–potential dependencies of a → *dropping mercury electrode*. For this invention, Heyrovský was awarded the Nobel Prize in Chemistry in 1959. In 1924 Shikata was appointed Professor of the Imperial University of Kyoto (presently Kyoto University). In 1942 he was appointed Vice-President of the Research Institute of



Shikata (left) and Heyrovský on Dec. 23, 1923 in London — Figure

Science of Manchuria (Tairiku-Kagakuin), and in 1953, eight years after the end of the World War II, returned to his home country. 1954–1959 Professor at Nagoya University. Also see → *polarography*.

Refs.: [i] Heyrovský J, Shikata M (1925) *Rec Trav Chim Pays-Bas* 44:496; [iii] Tachi I (1965) *Rev Polarogr (Kyoto)* 12:137

TO

Short-circuit current — It is the current supplied by an electrical → *power source* device if the two terminals of the device are connected, without associated dissipation → *resistance*, i.e., load resistance equal to zero. The short-circuit current is determined by the power source characteristics, given by the quotient between electromotive force and internal resistance. See also → *fill factor*.

Ref.: [i] Brophy JJ (1977) *Basic electronics for scientists*. Tosho Printing, Tokyo

IH

Shuttelcock battery → *rocking-chair batteries*

S

SI base units — The *Système International d'Unités* (SI) has 7 base units: kg (kilogram) for mass *M*, m (meter) for length *L*, s (second) for time *T*, K (kelvin) for temperature Θ , mol (mole) for the amount of a substance *N*, A (→ *ampere*) for electric current intensity *I*, and cd (candela) for luminous intensity *J*.

Refs.: [i] Mills I, Cvitas T, Homann K, Kallay N, Kuchitsu K (eds) (1993) *IUPAC quantities, units and symbols in physical chemistry*. Blackwell Scientific Publications, Oxford, p 7; [ii] Quack M, Frey J (2005) *IUPAC quantities, units and symbols in physical chemistry*, 3rd edn. *Pure Appl Chem Manuscript ID PAC-REC-05-11-10*; [iii] Cardarelli F (1997) *Scientific unit conversion. A practical guide to metrication*. Springer, London

FS

SI derived units — The following Table gives the SI derived units:

SI derived units — Table 1

Name	Sym- bol	Physical quantity	Equivalent in SI base units
Becquerel	Bq	radioactivity	1 Bq = 1 s ⁻¹
Coulomb	C	quantity of electricity, electric charge	1 C = 1 A s
Degree Celsius	°C	Celsius temperature*	
Farad	F	electric capacitance	1 F = 1 kg ⁻¹ m ⁻² s ⁴ A ²
Gray	Gy	absorbed dose of radiation, kerma	1 Gy = 1 m ² s ⁻²
Henry	H	electric inductance	1 H = 1 kg m ² s ⁻² A ⁻²

Hertz	Hz	frequency	1 Hz = 1 s ⁻¹
Joule	J	energy, heat work	1 J = 1 kg m ² s ⁻²
Katal	kat	catalytic activity	1 kat = 1 mol s ⁻¹
Lumen	lm	luminous flux	1 lm = 1 cd sr
Lux	lx	illuminance	1 lx = 1 cd sr m ⁻²
Newton	N	force, weight	1 N = 1 kg m s ⁻²
Ohm	Ω	electric resistance	1 Ω = 1 kg m ² s ⁻³ A ⁻²
Pascal	Pa	pressure, stress	1 Pa = 1 kg m ⁻¹ s ⁻²
Poiseuille (pascal-second)	Pl	absolute viscosity, dynamic viscosity	1 Pl = 1 kg m ⁻¹ s ⁻¹
Radian	rad	plane angle	1 rad = m m ⁻¹ = 1
Siemens	S	electric conductance	1 S = 1 kg ⁻¹ m ⁻² s ³ A ²
Sievert	Sv	dose equivalent, dose equivalent index	1 Sv = 1 m ² s ⁻²
Steradian	sr	solid angle	1 sr = 1 m ² m ⁻² = 1
Tesla	T	induction field, magnetic flux density	1 T = 1 kg A ⁻¹ s ⁻²
Volt	V	electric potential, electromotive force	1 V = 1 kg m ² s ⁻³ A ⁻¹
Watt	W	power, radiant flux	1 W = 1 kg m ² s ⁻³
Weber	Wb	induction magnetic flux	1 Wb = 1 kg m ² s ⁻² A ⁻¹

* The Celsius temperature is defined by the equation
 $t/^{\circ}\text{C} = T/\text{K} - 273.15$

Fundamental physical constants used as units (the astronomical length is not given here because of irrelevance for electrochemistry):

SI derived units — Table 2

Name	Sym- bol	Physical quantity	Equivalent in SI base units
Electronvolt	eV	energy	1 eV = 1.60217653(14) × 10 ⁻¹⁹ J
Dalton, unified atomic mass unit	Da, u	mass	1 Da = 1.66053886(28) × 10 ⁻²⁷ kg

(The → *Faraday constant* is not recognized as a unit by the Comité International des Poids et Mesures, however, one may find it occasionally wrongly used as such in electrochemical literature.)

Refs.: [i] Quack M, Frey J (eds) (2005) *IUPAC quantities, units and symbols in physical chemistry*, 3rd edn. *Pure Appl Chem Manuscript ID PAC-REC-05-11-10*; [ii] Cardarelli F (1997) *Scientific unit conversion. A practical guide to metrication*. Springer, London

FS

Side reactions (and side reaction coefficients) — Reactions that accompany a main reaction or electrochemical system. Example: When the redox system Fe(II)/Fe(III) in aqueous solutions is studied, the following redox equilibrium is the main reaction: $\text{Fe}^{3+} + \text{e}^- \rightleftharpoons \text{Fe}^{2+}$. Since the standard potential of that system relates to the two aqua complexes $[\text{Fe}(\text{H}_2\text{O})_6]^{3+}$ and $[\text{Fe}(\text{H}_2\text{O})_6]^{2+}$, a number of possible side reactions (in fact equilibria!) have to be taken into account: the Fe(III) hexaqua complex is prone to acid–base reactions according to $[\text{Fe}(\text{H}_2\text{O})_6]^{3+} + \text{H}_2\text{O} \rightleftharpoons [\text{Fe}(\text{H}_2\text{O})_5\text{OH}]^{2+} + \text{H}_3\text{O}^+$, etc., and follow-up condensation reactions, and both Fe(III) and Fe(II) ions may form complexes with other ligands in the solution. The side reactions are mathematically treated by defining side-reaction coefficients $\alpha_{\text{Fe(III)}}$ and $\alpha_{\text{Fe(II)}}$ as follows: $\alpha_{\text{Fe(III)}} = c_{[\text{Fe}(\text{H}_2\text{O})_6]^{3+}}/c_{\text{Fe(III),total}}$ and $\alpha_{\text{Fe(II)}} = c_{[\text{Fe}(\text{H}_2\text{O})_5\text{OH}]^{2+}}/c_{\text{Fe(II),total}}$ with $c_{\text{Fe(III),total}}$ and $c_{\text{Fe(II),total}}$ being the sums of all iron(III) and iron(II) species in the solution. See also → *conditional (apparent) equilibrium constants*, → *equilibrium*, → *potential*, → *formal potential*.

FS

Siemens, Ernst Werner von



(Dec. 13, 1816, Poggenhagen, Hannover, Germany – Dec. 6, 1892, Charlottenburg, Berlin, Germany) Siemens was educated at home by a tutor. From 1832 to 1834 he attended the Katharinen Gymnasium in Lübeck, but left without completing his examinations. Unable to afford a university education, he joined the Prussian Army's Engineering Corps as a cadet. This gave him access to the Artillery school in Magdeburg, where he began studies at the end of 1834. By autumn 1835 he had transferred to the Royal Artillery and Engineering School in Berlin where he remained until 1838. In that year he was commissioned second lieutenant in the Prussian Army. Following a short prison sentence (for acting as a second in a duel) he produced his first invention, a silver plating process, in 1842. A few years later, in collaboration with

another engineer called Johann Georg Halske (1814–1890), he developed a “needle-pointer” telegraph (1847). Based on this invention, the pair founded the company Telegraphen Bau-Anstalt von Siemens & Halske on October 1, 1847. This company was an instant success. By 1848 they had built a 500 km underground telegraph line between Berlin and Frankfurt am Main. Shortly thereafter the Company expanded to London, Paris, St. Petersburg, and Vienna. Though he now found himself the head of a multinational enterprise, Siemens continued to carry out fundamental research. In January 1850 he published a paper in which he discussed methods of locating faults in underground wires. In 1855 he was granted a patent on a method of transmitting telegraph messages in opposite directions at the same time. Having often complained about the lack of a reproducible standard of electrical → *resistance*, he then solved the problem himself by using a column of pure mercury one meter high and one square millimeter in cross-section, at a temperature of 0 °C. In 1875–77 he developed the selenium photometer, whose response depended on changes in electrical conductance as a function of light intensity. Meanwhile, the Company of Siemens & Halske prospered. In 1866 they manufactured a dynamo that could be set in motion by the residual magnetism of its electromagnet, thus removing the need for a separate exciting current. This new generation of dynamos made “Siemens” a household name. Among his further engineering successes were the completion of an 11,000 km telegraph line between London and Calcutta (now Kolkata, West Bengal) in 1870, the patenting of a moving-coil transducer (1877), which later formed the basis of the loudspeaker, the demonstration of the first electrically-driven railway (1879), and the illumination of a boulevard in Berlin using arc lamps (1882). He also coined the word “Elektrotechnik” in German, meaning “electrical engineering”. Siemens received many honors during his lifetime, including an honorary doctorate from the University of Berlin (1860), membership of the Royal Prussian Academy of Sciences (1873), and election to the Prussian Order Pour le Mérite (1886). In 1888 he was raised to the nobility by Kaiser Friedrich III (1831–88). Today, the → *SI unit* of electrical conductance, the siemens (symbol S) is named in his honor.

Ref.: [i] (vol 1: 1892, vol: 2 1895) *Scientific & technical papers of Werner von Siemens. Vol 1: Scientific papers and addresses. Vol 2: Technical papers. London*

SF

Siemens — The SI derived unit for the admittance (Y), conductance (G), or susceptance (B). Its symbol

is the uppercase S. It is defined as: $1\text{ S} = 1\Omega^{-1} = 1\text{ kg}^{-1}\text{ m}^{-2}\text{ s}^3\text{ A}^2$, and is equivalent to the now-obsolete mho. It is named after the German inventor and industrialist → *Siemens*. In English, *siemens* is used for singular or plural expressions [i].

Ref.: [i] Cardarelli F (1997) *Scientific unit conversion. A practical guide to metrication*. Springer, London

Siemens-Halske cell — This was a variant of the → *Daniell cell*. See also → *zinc*, → *Zn²⁺/Zn electrodes*, → *Zn²⁺/Zn(Hg) electrodes*, → *zinc-air batteries (cell)*, and → *Leclanché cell*.

Ref.: [i] Hauck WP (1883) *Die Galvanischen Batterien, Accumulatoren und Thermo Säulen*, 2nd edn. Hartleben's Verlag, Wien

Sievert's law → *hydrogen absorption*

Signal averaging — A mathematical process performed by analog or digital media, in which measurements collected during a number of precise periods are added to reduce the random → *noise*. Thus, the nonrandom signal is added directly with respect to the integration time, whereas the random noise is added as the square root of the integration time [i].

Ref.: [i] Horowitz P, Hill W (2001) *The art of electronics*. Cambridge University Press, Cambridge

Signal filtering — A process used to eliminate unwanted frequencies, generated by electronic devices during the detection procedure, from a measured signal. Different → *analog filters* and → *digital filters* have been developed to increase the → *SNR*. There are three common kinds of filters that can be implemented by hardware media and used to select the band of measured frequencies:

Low-pass filter — A system that allows the passage of all signals below a predetermined cutoff frequency.

High-pass filter — A system that allows the transmission of all frequencies above a given cutoff value.

Band-pass filter — A system that admits only the passage of a determined range of frequencies and blocks signals with frequencies out of such range.

Band-stop filter — A system that blocks the passage of a determined range of frequencies and admits signals with frequencies out of such range.

Additionally, the → *sampling rate* must be controlled when filters are used. High-pass and low-pass filters might eliminate a desired signal if it is scanned too slow or too fast, respectively.

On the other hand, there are measurements in which signal and noise cannot be directly filtered and the signal has to be transposed onto a carrier wave to be shifted away from the noise frequencies (modulation). Then an amplifier is tuned to the frequency of the carrier wave and the amplified original signal is finally recovered (demodulation). The use of a chopper in optical spectrophotometers is a common example of this process [i].

Ref.: [i] Horowitz P, Hill W (2001) *The art of electronics*. Cambridge University Press, Cambridge

FG

Signal-to-noise ratio (SNR or S/N) — The ratio between the squared amplitudes (power) of the desired signal and the *noise* that is mixed in with it. It can be simply calculated as $\text{SNR} = P_{\text{signal}}/P_{\text{noise}} = (A_{\text{signal}}/A_{\text{noise}})^2$, P is average power and A is the → *root mean square* amplitude. However, many electrochemical experiments usually involve DC signals for which the SNR can be calculated as the ratio of the average impulse of the signal (the peak) to the → *root mean square* of the → *noise* amplitude (the peak-to-peak difference). In contrast, the SNR of

FG

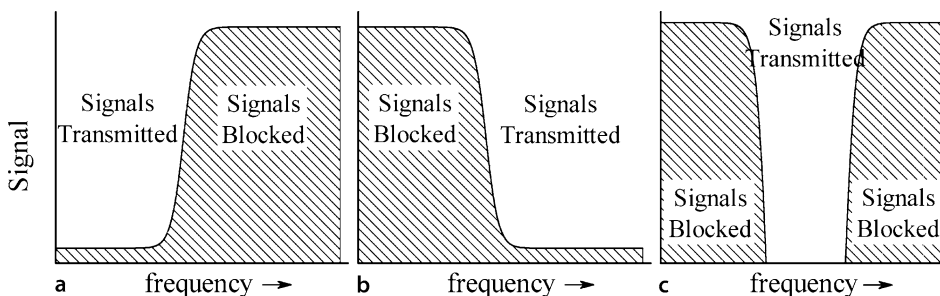

Signal filtering — Figure. Filter types: a low-pass, b high-pass, and c band-pass

→ AC signals with a very wide dynamic range should be expressed according to the following logarithmic decibel expression: $\text{SNR (dB)} = 10 \log_{10}(P_{\text{signal}}/P_{\text{noise}}) = 20 \log_{10}(A_{\text{signal}}/A_{\text{noise}})$. When using digital storage, the number of bits of the analog-to-digital conversion determines the maximum SNR. → *Signal averaging* is a powerful way to increase the SNR of a measurement [i].

Ref.: [i] Horowitz P, Hill W (2001) *The art of electronics*. Cambridge University Press, Cambridge

FG

Significant figure — A convention for recording quantitative data in which all the certain, or actually read, digits plus the first uncertain, or estimated, digit are used to write the resulting number of a measurement [i].

Ref.: [i] Mendham J, Denney R, Barnes J, Thomas M (2000) *Vogel's quantitative chemical analysis*. Prentice Hall, New Jersey

FG

Silicon electrochemistry — Silicon is the key player in the electronics and physics industry due to its semiconducting properties, which make it an ideal substrate for various elementary electronics' devices. Despite its well-understood characteristics in materials science, silicon electrochemistry is far less known. The electronic properties of silicon are essential in the understanding of silicon as an electrode material in electrochemical systems. Two kinds of charge carriers, → *electrons* and → *holes*, are present in silicon because it is a → *semiconductor*. The energy gap between the → *conduction band* (CB) and the → *valence band* (VB) in silicon is 1.11 eV at RT, which limits the upper operation temperature for silicon devices to about 200 °C. Silicon is probably the only solid element that is currently produced in the purest form. Contamination levels as low as a few parts per trillion (ppt), corresponding to less than 10^{11} cm^{-3} , are achievable. Such a pure silicon crystal is termed 'intrinsic' and exhibits a specific resistivity of about 10 kΩ cm at RT, corresponding to a concentration of charge carriers of $1.45 \times 10^{10} \text{ cm}^{-3}$ at room temperature. This low concentration of impurities can be increased by doping with Group III elements (B, Al, Ga, In), producing *p*-type Si, or by doping with Group V elements (P, As, Sb), producing *n*-type Si.

The chemical dissolution of silicon can be obtained in both liquid and gaseous media. The latter is known as dry etching or reactive ion etching (RIE) and is used in today's microelectronic manufacturing. However, wet processes related to silicon are also very important, as one third of the total number of process steps for the fabrication of today's integrated circuits involve

wet etching and cleaning procedures, illustrating the importance of wet processing. There are numerous methods for silicon dissolution, but they are beyond the scope of this dictionary.

The electrochemistry of silicon is highly important as a tool for surface treatment and the formation of porous silicon. Under the reverse bias (anodic for *n*-type, cathodic for *p*-type) of silicon immersed in an electrolyte, a space charge layer is formed near the electrode surface, in which the concentration of the charge carriers differs from that of the bulk material. The width of this space charge layer depends on the type and density of dopants in the material and the potential bias.

The current-voltage (*I*-*U*) characteristic of a semiconductor-electrolyte interface is determined by both the semiconducting nature of the electrode, as well as by the ionic and molecular species present in the electrolyte. The current density at the electrode for a certain potential is limited by the reaction kinetics at the interface, or by the charge supply from the electrode or the electrolyte. When a *p*-type electrode is cathodically biased, the current is minimal in dark conditions and will increase only upon illumination due to the formation of electrons by excitation. For an *n*-type electrode, a similar behavior is observed under anodic bias. Some of the electrochemistry characteristics of silicon electrodes in acidic, and specially hydrofluoric electrolytes, are unique. Under cathodic potentials, the *I*-*V* curve is governed by the reduction of protons to form hydrogen; therefore, the nature of the anions in the electrolyte has no effect. Under anodic bias, a passivating film is formed according to the following reaction:



The reaction path in the presence of HF is quite different:

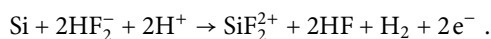

Thus, no passivating layer is formed due to the fact that silicon dissolves in such media. Therefore, the anodic *I*-*V* curve of silicon in HF is quite unique and differs from the *I*-*V* curves obtained in acidic (HF-free) and alkaline electrolytes. Less attention has been paid to the electrochemistry of silicon in alkaline electrolytes as compared to the study of the electrochemistry of silicon in acidic electrolytes, probably due to the fact that pore formation is observed only in acidic media. In contrast to acidic solutions, silicon dissolution occurs in alkaline solutions under → *open circuit potential* (OCP).

Under cathodic bias, the chemical dissolution is accompanied by electrochemical reactions, which reduce Si dissolution. Under slightly anodic potentials, the

chemical dissolution is accompanied by an electrochemical dissolution, which leads to an enhanced rate of silicon dissolution. → *Passivation* of silicon occurs in both acidic and basic media due to the formation of oxides.

The mechanism of pore formation in silicon (and other materials) has been explored and understood. In general, a basic requirement for electrochemical pore formation is the passivation of the pore walls and passivity breakdown at the pore tips.

Examples of applications of silicon electrochemistry are: exploiting the properties of the silicon–electrolyte contact for analytical purposes, e.g., HF tester and pin-hole detector, which directly exploit the special properties of the electrochemical reactions at anodically- or cathodically-polarized silicon electrodes, and the preparation of devices based on porous silicon and silicon oxide (formed by anodic processes).

Recent studies in silicon electrochemistry include the formation of different kinds of porous silicon with good control of pore size and morphology, the preparation of modified electrodes combining conducting silicon (by doping), and the self-assembly processes and further chemical linking of functional groups. Finally, there has been extensive work in recent years on the use of silicon as a material for negative electrodes in rechargeable Li batteries. Silicon may undergo reversible alloying with lithium in polar aprotic solutions according to the formula:

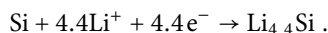

Li–silicon has a specific capacity greater than that of Li metal and a red–ox potential of <1 V vs. Li/Li⁺. Extensive studies are carried out throughout the world in order to develop Si–C composites and intermetallic compounds containing silicon as novel anodes for high energy density, rechargeable → *lithium batteries*.

Refs.: [i] Hayamazu Y, Hamagushi T, Ushio S, Abe T (1991) *J Appl Phys* 69:3077; [ii] Lehmann V (2002) *Electrochemistry of silicon: instrumentation, science, materials and applications*. Wiley-VCH; [iii] Jansen H, Gardeniers H, de Boer M, Elwenspoek M, Fluitman J (1996) *J Micromech Microeng* 6:14; [iv] Foll H (1991) *Appl Phys A* 53:8; [v] Xing WB, Wilson AM, Eguchi K, Zank G, Dahn JR (1997) *J Electrochem Soc* 144:2410; [vi] Chemla M (2006) *Silicon*. In: Bard AJ, Startmann M, Scholz F, Pickett CJ (eds) *Inorganic chemistry. Encyclopedia of electrochemistry*, vol. 7a. Wiley-VCH, Weinheim, pp 303

DA, EP

Silver → *electrode materials*, → *electrode of the second kind*

Silver coulometer → *coulometer*

Silver–silver chloride electrode → *reference electrode*

Silver cation conductors → *solid electrolyte*

Silver conducting solid electrolyte → *solid electrolyte*

Simons process — Electrochemical polyfluorination reactions of organic compounds are the only efficient way to industrial production of perfluorinated compounds. The reaction proceeds in the solution of KF in liquid HF (b.p. 19.5 °C), where the starting substances as alcohols, amines, ethers, esters, aliphatic hydrocarbons and halo-hydrocarbons, aromatic and heterocyclic compounds, sulfo- or carboxylic acids are dissolved. During anodic oxidation, splitting of the C–H bonds and saturation of the C=C bonds occur and fluorine atoms are introduced.

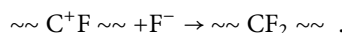
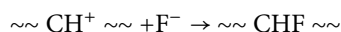

Refs.: [i] Simons JH (1949) *J Electrochem Soc* 95:53; [ii] Rudge AJ (1971) In: Kuhn AT (ed) *Industrial electrochemical processes*. Elsevier, Amsterdam, p 71; [iii] Laurent E, Lefranc H, Tardivel RR (1984) *Nouv J Chim* 8:345; [iv] More GGI, Hansen JC, Barrett TM, Waddell JE, Jewell KM, Kestner TA, Payfer RM (1986) *J Fluorine Chem* 32:41

JL

Sinsteden, Wilhelm Josef



(May 6, 1803, Kleve, Germany – Nov. 12, 1891, Xanten, Germany) Sinsteden was a medical doctor and physicist. He constructed several electric devices [i]. In 1854 he observed the formation of PbO₂ during electrolysis of sulfuric acid with lead electrodes, and noticed that a ‘secondary current’ flows following interruption of the electrolysis [ii]. This gave the impetus to the development of the → *lead–acid accumulator* by → *Planté*.

Ref.: [i] Euler K-J (1980) *Sinsteden – Planté – Tudor. Zur Geschichte des Bleiakкумуляtors*. Kassel, VDE-Ausschuß *Geschichte der Elektrotechnik*; [ii] Sinsteden J (1854) *Ann Phys* 92:1

FS

Slater cell — This was a → *chromic acid battery* with nickel anodes.

Ref.: [i] Hauck WP (1883) *Die Galvanischen Batterien, Accumulatoren und Thermosäulen*, 2nd edn. Hartleben's Verlag, Wien

FS

Smee cell — This was a → *battery* consisting of an amalgamated zinc electrode and a → *platinized platinum electrode*. The latter can be also a *platinized silver electrode*. Both electrodes are placed in dilute sulfuric acid.

See also → *zinc*, → *Zn²⁺/Zn electrodes*, → *Zn²⁺/Zn(Hg) electrodes*, → *zinc-air batteries (cell)*, and → *Leclanché cell*.

Ref.: [i] Hauck WP (1883) *Die Galvanischen Batterien, Accumulatoren und Thermosäulen*, 2nd edn. Hartleben's Verlag, Wien

FS

Smith, Edgar Fahs



(May 23, 1854, York, Pennsylvania, USA – May 3, 1928, Philadelphia, USA) American chemist who obtained a Ph.D. from University of Göttingen, Germany, where he worked under the direction of Friedrich Wöhler. Smith contributed to → *electrogravimetry* by developing numerous new determinations, and he is credited for popularizing electrochemical methods of analysis [i]. He is also well remembered for his publications on the history of chemistry [ii]. The American Chemical Society takes care of the “The Edgar Fahs Smith Memorial Collection in the History of Chemistry”.

Refs.: [i] Smith EF (1890) *Electrochemical analysis*. P. Blakiston, Philadelphia (Reprinted by Kessinger Publishing, Whitefish 2007) 2nd edn. 1894, 3rd edn. 1902, 4th edn. as ‘*Electro-Analysis*’. 1907, 5th edn. 1912, translations to German and French were also published); [ii] Smith EF (1914) *Chemistry in America*. Appleton, New York 1914

FS

Smoler, Ivan



(Courtesy of Petr Zuman, USA)

(Mar. 13, 1901, St. Petersburg, Russia – Feb. 24, 1990, Prague, Czechoslovakia) Student, later co-worker of → *Heyrovský, J.* at the Polarographic Institute. On the basis of highly precise experimental measurements he designed a special capillary [i] for the → *dropping mercury electrode*, which eliminates transfer of electrolytic products among subsequent drops and hence allows exact comparison of polarographic theory with experiment [ii].

Refs.: [i] Smoler I (1963) *J Electroanal Chem* 6:465; [ii] Smoler I (1966) *Coll Czech Chem Commun* 31:703

MHey

Smoluchowski, Marian (Marian, Ritter von Smolan Smoluchowski)



Polish scientist (May 28, 1872, Vorderbrühl/Vienna, Austria – Sep. 5, 1917, Krakau, Austro-Hungarian Empire, now Kraków, Poland) 1890–1894 study of physics at Vienna University, 1895 Ph.D. in physics at Vienna University, 1895–1898 research with → *Lippmann*, Lord Kelvin, and Warburg; 1898 habilitation at Vienna University; 1900 associate professor of theoretical physics at Lwów (Lvov, Lviv) University; 1903 full professor of theoretical physics at Lwów University; 1913 full professor of experimental physics and rector (1917) at the Jagellonian

University, Kraków [i]. He described Brownian molecular motion independently from \rightarrow Einstein considering the collisions explicitly between a particle and the surrounding solvent molecules [ii], worked on colloids [iv–v], and obtained an expression for the rate with which two particles diffuse together (\rightarrow Smoluchowski equation (b)) [iii–v]. He also derived an equation for the limiting velocity of electroosmotic flow through a capillary (\rightarrow Smoluchowski equation (a)).

Refs.: [i] Laidler KJ (1995) *The world of physical chemistry*. Oxford University Press, Oxford, pp 276–277, 296; [ii] Smoluchowski M (1906) *Ann Phys* [4] 21:756; [iii] Smoluchowski M (1916) *Phys Z* 17:557, 585; [iv] Smoluchowski M (1917) *Z phys Chem* 92:129

RH

Smoluchowski equation — There are several equations which are referred to as \rightarrow Smoluchowski equation. The most important are:

- (a) The \rightarrow electroosmotic flow of a fluid through a capillary will occur with a velocity that is zero at the plane of shear and rises to a limiting value v_s beyond the \rightarrow double layer. That limiting velocity is given by the Smoluchowski equation $v_s = -\varepsilon_0 \varepsilon_r \zeta E / \eta$, where ε_0 is the \rightarrow permittivity of vacuum, ε_r is the \rightarrow dielectric constant of the fluid, ζ is the equilibrium potential at the ‘plane of shear’ (\rightarrow zeta potential), E is the electric field strength, and η is the \rightarrow viscosity. The equation is valid for very thin double layers, in the absence of a pressure gradient and gravity effects. The same equation describes also the velocity of a particle under conditions of \rightarrow electrophoresis: $v = -\varepsilon_0 \varepsilon_r \zeta E / \eta$, where ε_r is the \rightarrow dielectric constant of the material of the particle. This equation is valid only when the double layer thickness is small compared to the radius of the particle, i.e., $\kappa r \gg 1$ (κ is the \rightarrow Debye–Hückel parameter and r is the particle radius). For the case of $\kappa r \ll 1$ the \rightarrow Hückel equation of electrophoretic mobility is valid.

Refs.: [i] Smoluchowski M (1903) *Bull Int Acad Sci Cracovie* 184; [ii] Hunter RJ (2004) *Foundations of colloid science*, 2nd edn. Oxford University Press, Oxford, pp 375; [iii] Morrison ID, Ross S (2002) *Colloidal dispersions. Suspensions, emulsions, and foams*. Wiley Interscience, New York, pp 334

FS

- (b) It is an expression, derived by \rightarrow Smoluchowski [i], for the rate coefficient (k_d) with which two particles (A and B) diffuse together: $k_D = 4\pi(D_A + D_B)d_{AB}$ where D_A and D_B are the \rightarrow diffusion coefficients of

species A and B, and d_{AB} is the distance between their centers. In liquid solutions k_d is equal to approximately $7 \times 10^9 \text{ dm}^3 \text{ mol}^{-1} \text{ s}^{-1}$ [ii]. This equation was initially derived by Smoluchowski to describe the rate of coagulation of colloids [iii]. However, it can be also applied to ionic reactions: The rate of ionic reactions are usually higher in solutions, therefore these reactions are diffusion controlled. If the rate coefficient of the reaction is much lower than k_d , the reaction is kinetically controlled. The theory of diffusion control for ionic reactions was derived by \rightarrow Debye [iv].

See also \rightarrow Einstein–Smoluchowski equation.

Refs.: [i] Smoluchowski M (1916) *Phys Z* 17:557, 585; [ii] Laidler KJ (1995) *The world of physical chemistry*. Oxford University Press, Oxford, pp 276–277, 296; [iii] Evans FD, Wennerström H (1999) *The colloidal domain. Where physics, chemistry, and biology meet*. Wiley-VCH, New York, pp 417; [iv] Debye P (1942) *Trans Electrochem Soc* 82:265

GI

Smoothing — The action taken upon experimental data to remove unwanted electrical \rightarrow noise (ripples) and therefore to make the obtained dependencies look well (smooth). Most electrochemical instruments are equipped with rather simple electronic circuits that help in smoothing the curves at the time of the recording. The use of these circuits should be done with care not to change the true shape of the measured dependencies. Several digital procedures for the data smoothing, like e.g., the moving-average method, are also known. They are very useful in the case of the white noise (random combination of frequencies and intensities). When the data are loaded with a noise of well-determined frequency, then the Fourier transform (\rightarrow Fourier transformation) can be used, however, this kind of action is rather called noise filtering. More complicated are the situations when either frequency or intensity of the noise changes in time. Then the smoothing process is rather complex and may work only in a part of a curve.

Ref.: [i] O’Haver T: <http://www.wam.umd.edu/~toh/spectrum/Smoothing.html>

ZS

SNR \rightarrow signal-to-noise ratio

SoC \rightarrow state of charge

Söderberg anode (or electrode) — This electrode is named to honor the Swedish–Norwegian engineer Carl Wilhelm Söderberg (1876–1955). It is a continuously

formed and spent \rightarrow carbon \rightarrow anode, mainly used for \rightarrow aluminum production, in which a mixture of petroleum coke and coal-tar pitch is continuously fed to a steel casing and is baked as it passes through the heated casing. Thus, the baked anode emerging into the cell, continuously replaces the anode being sacrificed. The Söderberg anode may be oriented either vertically or horizontally. The self-baking or in-cell Söderberg method is one of the two common industrial-scale methods to form carbon anodes, beside the pre-bake method, where the carbon anodes are fully formed and completed in ovens outside the reduction cell. Industrial-scale processes that make regular use of Söderberg anode, are the \rightarrow Hall-Héroult process, and the production processes of calcium carbide and white phosphorus. Horizontal stud Söderberg anode cell (HSS), and vertical stud Söderberg anode cell (VSS) are, beside the prebaked or so-called "green" anode cell, used for the electrolytic Al reduction. All three configurations require a 'paste' (petroleum coke mixed with a pitch binder). Paste preparation includes the crushing, grinding, and screening of coke and cleaned spent anodes (butts) and blending the coke with a pitch binder in a steam-jacketed mixer. For Söderberg anode, the thick paste mixture is added at the top of a rectangular casing that is typically 6–8 m long, 2 m wide, and 1 m high, which is directly baked in the aluminum reduction cell. Prebaked anode cells are preferred over Söderberg cells, because they are electrically more efficient (Söderberg anodes have an about 30% higher electrical resistivity), and emit fewer volatile organic compounds, i.e., require less-efficient emission control devices. Moreover, they are not constrained by operating requirements and cell design configurations, as the Söderberg anode. The horizontal stud configuration is used more frequently than the vertical one. The cell casing is made of aluminum or steel sheeting, with a permanent steel skirt and perforated steel channels through which electrode connections (studs) are inserted horizontally into the anode paste. During reduction, as the baking anode is consumed, the lower row of studs and the bottom channel are removed, and flexible electrical connectors are moved to a higher row of studs. The VSS cell is similar to the HSS cell, except that the studs are mounted vertically in the anode paste. VSS construction prevents the installation of an integral gas collection device, and hoods are restricted to canopies or skirts at the base of the cells where the hot anodes enter the cell baths.

Ref.: [1] Frank WB, Haupin WE (2002) *Aluminum*. In: *Ullmann's encyclopedia of industrial chemistry*, 6th edn. Wiley-VCH

Sodium cation conductors \rightarrow solid electrolyte

Sodium conducting solid electrolyte \rightarrow solid electrolyte

Sodium/Potassium pump \rightarrow ion transport through membranes and ion channels

Sodium-sulfur battery — Secondary \rightarrow battery employing molten sodium and molten sulfur/sodium sulfide) as active masses and a sodium-conducting aluminum oxide as solid electrolyte operating at about $T = 350^\circ\text{C}$. The electrode reactions are



and

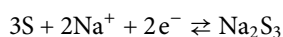

with the cell reaction

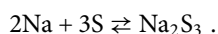

Upon discharge sodium ions diffuse through the sodium-conducting \rightarrow β - or β'' -alumina or \rightarrow NASICON \rightarrow solid electrolyte. On the outer surface of the solid electrolyte they react with molten sulfur and/or low valency sulfide anions forming negatively charged polysulfide anions. The rather low electric conductivity of molten sulfur is improved by addition of tetracyanoethylene

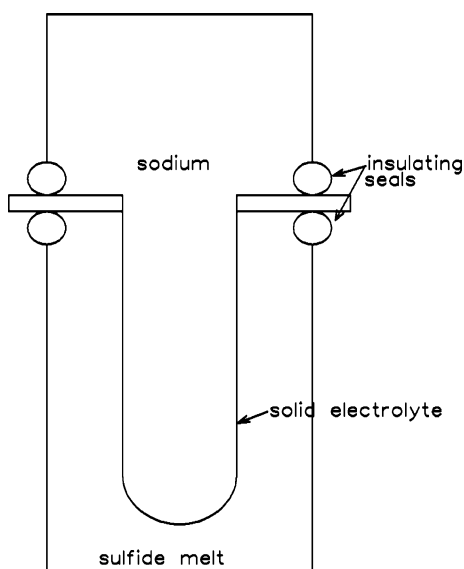

Sodium-sulfur battery — Figure. Schematic cross section of a sodium-sulfur battery

$(\text{CN})_2\text{C}=\text{C}(\text{CN})_2$; this addition also improves the electrode kinetics. Current collection is improved by adding \rightarrow graphite felt mats into the electrode volume.

Ref.: [i] Sudworth JL, Tilley AR (1985) *The sodium sulfur battery*. Chapman & Hall, New York

RH

Solid electrolyte — is a class of solid materials, where the predominant charge carriers are \rightarrow ions. This term is commonly used for \rightarrow conducting solids with ion \rightarrow transport number equal to or higher than 0.99 (see also \rightarrow electrolytic domain). Such a requirement can only be satisfied if the \rightarrow concentration and \rightarrow mobility of ionic \rightarrow charge carriers (usually \rightarrow vacancies or interstitials) both are relatively high, whilst the content of \rightarrow electronic defects is low. See also \rightarrow superionics, \rightarrow defects in solids, \rightarrow diffusion, and \rightarrow Nernst–Einstein equation.

Solid electrolytes with mono-, bi-, and trivalent ion charge carriers are known. Important examples include:

- Silver (Ag^+) cation conductors: α -phase of AgI , Ag_3SI , Ag_2HgI_4 , RbAg_4I_5 , $\text{Ag}_{16}\text{I}_{12}\text{P}_2\text{O}_7$, $\text{Ag}_{26}\text{I}_{18}\text{W}_4\text{O}_{16}$, $(\text{C}_5\text{H}_5\text{NH})\text{Ag}_5\text{I}_6$, Ag_2G ($\text{G} = \text{S}, \text{Se}$), Ag -containing glasses such as those in the systems $\text{AgI}-\text{Ag}_2\text{O}-\text{XO}_m$ ($\text{X} = \text{B}, \text{Te}, \text{V}, \text{P}, \text{Mo}, \text{As}, \text{W}, \text{Se}, \text{Pb}$).
 - Copper (Cu^+)-conducting electrolytes: α - CuI , $\text{M}'\text{Cu}_4\text{X}'_5$ ($\text{M}' = \text{Rb}, \text{Cs}$; $\text{X}' = \text{Cl}, \text{Br}, \text{I}$), Cu_2MI_4 ($\text{M} = \text{Hg}, \text{Cd}$), CuTeX' , various compounds comprising halide and copper ions and N -containing cyclic organic ligands, $\text{CuZr}_2(\text{PO}_4)_3$ and other Cu -containing analogues of \rightarrow NASICON, Cu -containing glasses based on the systems $\text{CuI}-\text{Cu}_2\text{O}-\text{XO}_m$.
 - Lithium (Li^+) cation conductors: Li_4ZO_4 ($\text{Z} = \text{Si}, \text{Ge}$), $\text{Li}_3\text{Z}'\text{O}_4$ ($\text{Z}' = \text{P}, \text{As}, \text{V}, \text{Cr}$), Li_3N , $\text{Li}_4\text{Zn}(\text{SO}_4)_3$, Li_2SO_4 and their derivatives, \rightarrow perovskites like $(\text{Li}, \text{Ln})\text{G}'\text{O}_3$ where Ln is a rare-earth cation and G' is a transition-metal cation with oxidation state higher than 3+, $\text{Li}_n\text{M}'_2(\text{PO}_4)_3$ ($\text{M} = \text{Sc}, \text{Cr}, \text{Fe}, \text{In}, \text{Ga}, \text{Al}, \text{Y}, \text{Zr}, \text{Ti}, \text{Hf}, \text{Ge}, \text{Sn}$) and other Li -containing analogues of NASICON, organic and glass materials similar to other monovalent-cation conductors, Li -containing \rightarrow β -alumina.
 - Sodium (Na^+) cation conductors: the families of NASICON and Na - β -alumina, Na_3PO_4 , Na_2SO_4 , $\text{Na}_2\text{ZnSiO}_4$, and their derivatives, $\text{Na}_m\text{MeP}_2\text{O}_{9+x}\text{F}_{1-x}$ ($\text{Me} = \text{Al}, \text{Fe}, \text{Cr}, \text{Ti}, \text{Ga}, \text{Ca}, \text{Sc}$), $\text{Na}_m\text{Me}'\text{T}_4\text{O}_{12}$ ($\text{Me}' = \text{In}, \text{Sc}, \text{Y}, \text{Lu-Sm}, \text{Fe}$;
- $\text{T} = \text{Si}, \text{Ge}$), various perovskites and Na -containing glasses as for other monovalent cation conductors.
- Potassium (K^+) cation conductors: K -containing β -alumina and analogues of NASICON, $\text{K}_{2x}(\text{Ti}_{8-y}\text{T}'_y)\text{O}_{16}$ ($\text{T}' = \text{Al}, \text{Mg}, \text{Ga}, \text{Zn}, \text{Ni}, \text{Fe}$), $\text{KT}''\text{O}_2$ ($\text{M} = \text{Al}, \text{Ga}, \text{Fe}$), KAlSi_2O_6 , K_2SO_4 , $\text{K}_2\text{P}_2\text{O}_7$, KZnGeO_4 and their derivatives, perovskites and glasses similar to other cation conductors.
 - Rubidium (Rb^+) conductors: Rb -containing β -alumina and NASICON analogues, Rb_2SO_4 , RbRO_2 ($\text{R} = \text{Ga}, \text{Fe}$), $\text{RbAlSi}_2\text{O}_6$, $\text{Rb}_4\text{P}_2\text{O}_7$ and their derivatives.
 - Thallium (Tl^+) conducting electrolytes: Tl -containing β -alumina, many \rightarrow pyrochlores containing Tl and hexa- and pentavalent cations, high-temperature modification of Tl_2ZnI_4 , $\text{Tl}_4\text{Nb}_6\text{O}_{17}$, $\text{Ta}_2\text{Nb}_{12}\text{O}_{31}$ and their derivatives.
 - Cesium (Cs^+) cation conductors: $\text{CsR}'\text{O}_2$ ($\text{R}' = \text{Al}, \text{Ga}, \text{Fe}$), doped $\text{Cs}_4\text{P}_2\text{O}_7$.
 - Materials with significant mobility of di- and trivalent cations (Mg^{2+} , Ca^{2+} , Sr^{2+} , Cd^{2+} , Zn^{2+} , Al^{3+} , Sc^{3+} , Ho^{3+} , Y^{3+}): the family of β -alumina, $\text{M}^{2+}\text{Zr}_4(\text{PO}_4)_6$, several vanadates and tungstenates of the corresponding metals such as $\text{Al}_2(\text{WO}_4)_3$, and their derivatives. In this case, however, the information available in literature is often scarce and additional studies of the ionic conduction mechanisms are often required.
 - Oxygen (O^{2-}) anion conductors: \rightarrow stabilized zirconia, stabilized \rightarrow bismuth oxide, \rightarrow BIMEVOX, doped \rightarrow cerium dioxide, numerous perovskite-type \rightarrow solid solutions derived from $\text{Ln}(\text{A})\text{B}'(\text{B}'')$ O_3 ($\text{A} = \text{Ca}, \text{Sr}, \text{Ba}$; $\text{B}' = \text{Ga}, \text{Al}, \text{In}$; $\text{B}'' = \text{Mg}, \text{Ni}, \text{Co}, \text{Fe}$), $\text{La}_2\text{Mo}_2\text{O}_7$ and its derivatives, pyrochlores based on Ln_2TiO_7 .
 - Fluoride (F^-) anion conductors: fluorides with general formula $\text{A}'\text{F}_n$ ($\text{A}' = \text{Ca}, \text{Sr}, \text{Ba}, \text{Pb}, \text{Cd}, \text{Bi}, \text{Ln}, \text{Sn}$ and their mixtures), and also oxy- and chloro-fluoride phases containing these metal cations. In the latter case, however, both types of anions are often mobile.
 - \rightarrow Proton conductors: perovskites based on $\text{A}(\text{L}, \text{L}')\text{O}_{3-\delta}$ ($\text{L} = \text{Ce}, \text{Zr}, \text{Ta}, \text{Nb}, \text{Ti}$; $\text{L}' = \text{Y}, \text{Yb}, \text{In}, \text{Ga}, \text{Al}$, etc.) and their derivatives, pyrochlores like $\text{Ln}_2\text{Zr}_2\text{O}_7$, most types of monovalent metal-cation

conductors listed above where protons can be incorporated into the disordered lattice or may substitute mobile metal cations, derivatives of numerous inorganic acids and metals salts, in particular phosphates like LaPO_4 , oxides of rare-earth and alkaline-earth metals in a hydrated state, and also numerous organic and composite materials (see also: \rightarrow *polymer electrolytes*, \rightarrow *PEM*).

Refs.: [i] Rickert H (1982) *Electrochemistry of solids. An introduction*. Springer, Berlin; [ii] Kudo T (1997) *Survey of types of solid electrolytes*. In: Gelling PJ, Bouwmeester HJM (eds) *The CRC handbook of solid state electrochemistry*. CRC Press, Boca Raton

VK

Solid-phase microextraction (SPME) — is a procedure originally developed for sample preconcentration in gas chromatography (GC). In this procedure a small-diameter fused silica optical fiber, coated with a liquid polymer phase such as poly(dimethylsiloxane), is immersed in an aqueous sample solution. The \rightarrow *analytes* partition into the polymer phase and are then thermally desorbed in the GC injector on the column. The same polymer coating is used as a stationary phase of capillary GC columns. The extraction is a non-exhaustive liquid-liquid extraction with the convenience that the “organic phase” is attached to the fiber. This fiber is contained in a syringe, which protects it and simplifies introduction of the fiber into a GC injector. Both uncoated and coated fibers with films of different GC stationary phases can be used. SPME can be successfully applied to the analysis of volatile chlorinated organic compounds, such as chlorinated organic solvents and substituted benzenes as well as nonvolatile chlorinated biphenyls.

In analysis of ionic analytes, SPME can be electrochemically aided if a conducting fiber, like a \rightarrow *carbon fiber*, is used that is coated with a film of a \rightarrow *conducting polymer*, like \rightarrow *polypyrrole*. Electrostatic uptake and release of the analyte is governed by potential switching that results in oxidation and neutralization of the polymer accompanied by ingress and egress of the analyte ions from the polymer film.

Refs.: [i] Arthur CL, Pawliszyn J (1990) *Anal Chem* 62:2145; [ii] Louch D, Motlagh S, Pawliszyn J (1992) *Anal Chem* 64:1187; [iii] Wu J, Yu X, Lord H, Pawliszyn J (2000) *Analyst* 125:391

WK

Solid oxide fuel cell — Solid oxide \rightarrow *fuel cell* (SOFC) is a device that converts the energy of combustion reactions (e.g., $\text{H}_2 + 1/2\text{O}_2$, $\text{CO} + 1/2\text{O}_2$, $\text{CH}_4 + 2\text{O}_2$) into electrical energy. It is therefore called a fuel cell. It comprises two \rightarrow *porous electrodes* that sandwich \rightarrow *solid*

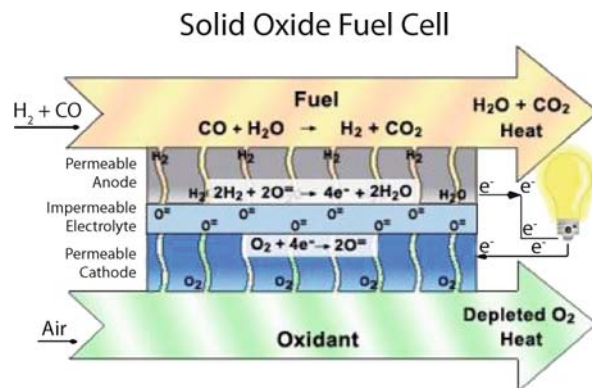

Solid oxide fuel cell — Figure 1. Operating concept of a SOFC [i]

electrolytes. Figure 1 shows schematically how a solid oxide fuel cell works. Air flows along the \rightarrow *cathode* (which is also called the \rightarrow *air electrode*). When oxygen molecules contact the cathode/electrolyte \rightarrow *interface*, they **catalytically** acquire four electrons from the cathode and split into two oxygen ions. These oxygen ions diffuse into the electrolyte material and migrate to the other side of the cell, where they encounter the anode (also called the “fuel electrode”). The oxygen ions encounter the oxidized fuel at the anode/electrolyte interface and react catalytically to generate water, carbon dioxide, heat, and, most important, electrons. The electrons transport through the anode to the external circuit and back to the cathode, providing a source of useful electrical energy in the external circuit.

This type of fuel cell operates at high temperatures, which means advantages in terms of good kinetics and the ability to use several types of fuel. There are two possible configurations for SOFCs: a planar design (Fig. 2) and a tubular design (Fig. 3). In the planar design, the components are assembled in flat stacks, with air and fuel flowing through channels built into the cathode and anode. In the tubular design, components are assembled in the form of a hollow tube, with the cell constructed in layers around a tubular cathode; air flows through the inside of the tube and fuel flows around the exterior.

Although the operating concept of SOFCs is rather simple, the selection of materials for the individual components presents enormous challenges. Each material must have the electrical properties required to perform its function in the cell. There must be enough chemical and structural stability to endure fabrication and operation at high temperatures. The fuel cell needs to run at high temperatures in order to achieve sufficiently high current densities and power output;

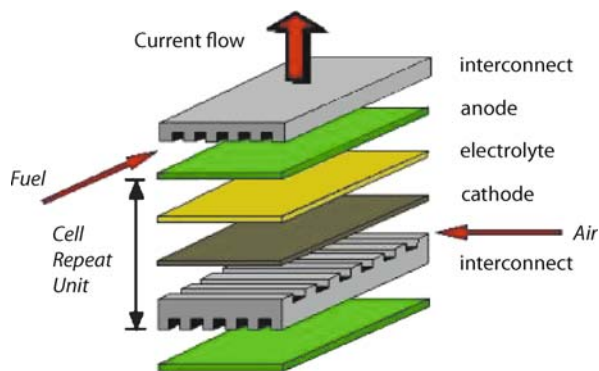

Solid oxide fuel cell — Figure 2. Configuration for a planar design SOFC [ii]

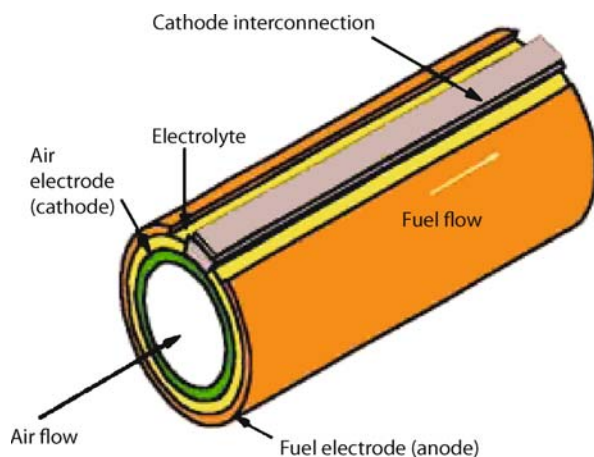

Solid oxide fuel cell — Figure 3. Configuration for a tubular design SOFC [iii]

operation at up to 1000 °C is possible using the most common electrolyte material, yttria-stabilized zirconia (YSZ) (\rightarrow *stabilized zirconia*). In order for SOFCs to reach their commercial potential, the materials and processing must also be cost-effective. The first successful SOFC used platinum as both the cathode and anode, but fortunately less expensive alternatives are available today [iv]. The cathode must meet all the above requirements and be porous in order to allow oxygen molecules to reach the electrode/electrolyte interface. In some designs (e.g., tubular) the cathode contributes over 90% of the cell's weight, and therefore provides structural support for the cell [v]. Today the most commonly used cathode material is lanthanum manganite (LaMnO_3), a *p*-type perovskite. Typically, it is doped with rare earth elements (e.g., Sr, Ce, Pr) to enhance its conductivity. Most often it is doped with strontium and is referred to as LSM ($\text{La}_{1-x}\text{Sr}_x\text{MnO}_3$).

The conductivity of these perovskites is all electronic (no ionic conductivity), which is a desirable feature.

The anode (the fuel electrode) must also have electrical conductivity, thermal expansion compatibility, and porosity, and must function in a reducing atmosphere. The reducing conditions combined with electrical conductivity requirements make metals attractive materials' candidates. Recent development has focused on a Ni-YSZ composite in which the YSZ provides structural support for separated Ni particles, preventing them from sintering together while matching the thermal expansions.

Refs.: [i] <http://www.seca.doe.gov>; [ii] <http://www.spice.or.jp/~fisher/sofc.html#descript>; [iii] <http://www.pg.siemens.com/en/fuelcells/sofc/tubular/index.cfm>; [iv] Weissbart J, Ruka R (1962) *J Electrochem Soc* 109:723; [v] Park S, Vohs JM, Gorte RJ (2000) *Nature* 404:265; [vi] Liou J, Liou P, Sheu T (1999) *Physical properties and crystal chemistry of bismuth oxide solid solution*. In: *Processing and characterization of electrochemical materials and devices*. Proc Symp Ceram Trans 109, Indianapolis, pp 3–10; [vii] Singhal SC (2000) *MRS Bull* 25:16; [viii] Matsuzaki Y, Yasuda I (2001) *J Electrochem Soc* 148:A126; [ix] Ralph JM, Kilner JA, Steele BCH (1999) *Improving Gd-doped ceria electrolytes for low temperature solid oxide fuel cells*. In: *New Materials for batteries and fuel cells*. Proc Symp San Francisco, pp 309–314

DA, BMA

Solid solutions — A solid solution is a single homogeneous phase of a solid-state material composed of two or more components which are infinitely (atomically or molecularly) mixed together. For crystalline solid materials, solid solutions are often classified into substitutional (where the host atoms or \rightarrow ions are replaced by foreign species) and interstitial (where the dopant species occupy positions which are normally empty in the parent structure) solid solutions. The \rightarrow *thermodynamics* of solid solutions is similar to that of liquid solutions, except for the limitations due to crystal-structure conservation requirements if any. The factors governing solid-solution formation in different systems are still understood only qualitatively, thus making it necessary to study phase relationships mainly by experimental methods. The most important factors include size and electronic configuration of the components, their capability to adopt given local coordination and type of chemical bonding. For systems with complete solid-solution ranges, the end-member phases should have the same crystal structure. Examples of solid solutions are: metal alloys in the range of good miscibility and nonstoichiometric metal oxides and chalcogenides, e.g., Cu_{2-x}S where two molecular components CuS and Cu_2S are homogeneously mixed forming solid solutions within

narrow compositional ranges corresponding to different minerals (such as chalcocite, djurleite, digenite, etc.). Most bulk doped \rightarrow *semiconductors* and \rightarrow *solid electrolyte* materials are solid solutions, provided that segregation processes, sometimes encountered during sample cooling, are absent. The phenomenon of solid-solution formation has key importance for optimization of properties of \rightarrow *conducting solids* and for \rightarrow *insertion electrodes*. See also: \rightarrow *doping*, \rightarrow *β -alumina*, \rightarrow *BIMEVOX*, \rightarrow *NASICON*, \rightarrow *stabilized zirconia*, \rightarrow *perovskites*.

Solid materials, even at elevated temperatures, may not often achieve thermodynamic equilibrium due to the slowness of mass transport in solid state. Metastable equilibria (well known for glasses) may then be established. This makes it possible to prepare metastable solid solutions in wider compositional ranges if compared to thermodynamic equilibrium, by using various synthesis techniques at relatively low temperatures.

The doped semiconductor materials can often be considered as well-characterized, diluted solid solutions. Here, the solutes are referred to as point defects, for instance, oxygen vacancies in TiO_{2-x} phase, denoted as $V_{\text{O}}^{\bullet\bullet}$, or boron atoms in silicon, substituting Si at Si sites, B_{Si}' , etc. See also: \rightarrow *defects in solids*, \rightarrow *Kröger–Vink notation* of defects. The atoms present at interstitial positions are also point defects. Under stable (or metastable) thermodynamic equilibrium in a diluted state, \rightarrow *chemical potentials* of point defects can be defined as follows:

$$\mu_i = \mu_i^\ominus + RT \ln c_i, \quad (1)$$

where μ_i is the chemical potential of point defects i , deviations of the activity coefficient from unity are neglected, μ_i^\ominus is standard chemical potential, c_i concentration [m^{-3}], R is the gas constant, and T absolute temperature. The limitations of this definition are associated with the necessity to account for non-ideality of realistic systems, and with theoretical impossibility to separate explicitly the chemical potential of a charged defect from those of other components. The selection of a standard state is often based on an infinite dilution principle, on the standard concentration of 1 m^{-3} (in practice: 1 cm^{-3}), and on the standard partial or total pressure (101,325 Pa). In many cases, other standard states are to be selected considering all relevant components of the system. Using equations analogous to Eq. (1), written for different kinds of point defects, most equilibria for reactions occurring between point defects can be described. For instance, dissociation of substitutional Zn in GaAs acting as an acceptor, can be described by:



$$\Delta G = \Delta G^\ominus + RT \ln \left(\frac{[\text{Zn}_{\text{Ga}}']}{[\text{Zn}_{\text{Ga}}^x]} \right) + RT \ln p \quad (3)$$

$$p = K \left(\frac{[\text{Zn}_{\text{Ga}}^x]}{[\text{Zn}_{\text{Ga}}']} \right), \quad (4)$$

where p is the concentration of electron holes, ΔG is the \rightarrow *Gibbs energy* for dissociation reaction (2), and K is the equilibrium constant.

The importance of point defect thermodynamics of solid solutions extends to lower temperatures, including room temperature and below, despite of freezing of the mass transport. Any distribution of point defects, with exclusion of electrons and holes, that is forced, in particular, by ion implantation at high electric fields or a controlled cooling program, can be used to design electronic devices, in which the electrons and holes, being delocalized and highly mobile, can compensate for the charge imbalances due to unevenness of point defect distribution and externally applied bias voltages. Similar concepts as used for charge transport in liquid solutions (diffusion coefficients, ionic mobility, etc.) are applied to electrons and holes in semiconductor solid solutions. At elevated temperatures, they are applied to all point defects.

Refs.: [i] Kröger FA (1973) *The chemistry of imperfect crystals*. North-Holland, New York; [ii] Hepel T, Hepel M (1977) *Electrochim Acta* 22:295; [iii] West AR (1984) *Solid state chemistry and its applications*. Wiley, Chichester

MHep

Solid solutions, electrochemical analysis of — Electrochemistry provides excellent means to distinguish a \rightarrow *solid solution* from a phase mixture because mixed phase thermodynamics leads to the effect that the individuality of electrochemical signals of the single phases is lost in a solid solution. Example: CuS and CuSe particles are reduced at different potentials when immobilized on an inert electrode and immersed in an aqueous electrolyte solution [i]. Solid solutions of these two compounds, i.e., $\text{CuS}_x\text{Se}_{1-x}$, show one reduction peak only, and that shifts depending on the molar ratio of the solid solution components. Such measurements can also be performed for X-ray amorphous solid solutions, where X-ray diffraction fails [ii]. Mixed silver halides have been studied with \rightarrow *potentiometry* as early as in 1901 [iii], and recently revived using \rightarrow *voltammetry* [iv]. Also in case of application of \rightarrow *solid electrolytes* and solid solutions as electrode materials the mixed phase thermodynamics leads to analogous effects, which can be revealed by coulometric \rightarrow *titration* or by measuring \rightarrow *electromotive force* of \rightarrow *concentration cells* [v]. See also: \rightarrow *gas titration*,

coulometric: – with solid electrolytes. This type of analysis may often be performed by indirect methods, such as → *conductometry*.

Refs.: [i] Meyer B, Zhang S, Scholz F (1996) *Fresenius J Anal Chem* 356:267; [ii] Reddy SJ, Dostal A, Scholz F (1996) *J Electroanal Chem* 403:209; [iii] Thiel A (1901) *Z anorg allg Chem* 24:1; [iv] Bond AM, Scholz F (1991) *Langmuir* 7:3197; [v] Kröger FA (1964) *The chemistry of imperfect crystals*. North-Holland, Amsterdam

FS, VK

Solid-state electrochemistry — is traditionally seen as that branch of electrochemistry which concerns (a) the → *charge transport* processes in → *solid electrolytes*, and (b) the electrode processes in → *insertion electrodes* (see also → *insertion electrochemistry*). More recently, also any other electrochemical reactions of **solid** compounds and materials are considered as part of solid state electrochemistry. Solid-state electrochemical systems are of great importance in many fields of science and technology including → *batteries*, → *fuel cells*, → *electrocatalysis*, → *photoelectrochemistry*, → *sensors*, and → *corrosion*. There are many different experimental approaches and types of applicable compounds. In general, solid-state electrochemical studies can be performed on thin solid films (→ *surface-modified electrodes*), microparticles (→ *voltammetry of immobilized microparticles*), and even with millimeter-size bulk materials immobilized on electrode surfaces or investigated with use of ultramicroelectrodes. The actual measurements can be performed with liquid or solid electrolytes.

See also → *β-alumina*, → *BIMEVOX*, → *bismuth oxide*, → *cerium dioxide*, → *conducting solids*, → *defects in solids*, → *diffusion coefficient* (– *determination in solids*), → *doping*, → *electrochemical gas compressor*, → *electrolytic permeability*, → *electronic defects*, → *four-electrode technique for conductivity measurements*, → *gas titration* (*coulometric*: – with solid electrolytes), → *gel layers*, → *Hebb–Wagner method*, → *hydrogen pumps*, → *Kröger–Vink notation*, → *NASICON*, → *oxygen pumps*, → *perovskites*, → *polymer modified electrodes*, → *polyoxometallates*, → *pyrochlores*, → *stabilized zirconia*, → *superionics*, → *vacancies*, → *Wagner enhancement factor*, → *Wagner equation*, → *Wagner factor*, → *Wagner number*, → *Wagner theory*.

Refs.: [i] Bruce PG (ed) (1995) *Solid state electrochemistry*. Cambridge University Press, Cambridge; [ii] Gellings PJ, Bouwmeester HJM (eds) (1997) *The CRC handbook of solid state electrochemistry*. CRC Press, Boca Raton; [iii] Maier J (2000) *Festkörper – Fehler und Funktion. Prinzipien der Physikalischen Festkörperchemie*. Teubner, Stuttgart; [iv] Fiedler DA, Scholz F (2001) *Electrochemical studies of solid compounds and materials*. In: Scholz F (ed) *Electroanalytical methods*. Springer,

Berlin, pp 211–222; [v] Kulesza PJ, Malik MA (1999) *Solid-state electrochemistry*. In: Wieckowski A (ed) *Interfacial electrochemistry. Theory, experiment, and applications*. Marcel Dekker, New York, pp 673–688; [vi] Surrridge NA, Jernigan JC, Dalton EF, Buck RP, Watanabe M, Zhang H, Pinkerton M, Wooster TT, Longmire ML, Facci JS, Murray RW (1989) *Faraday Discuss Chem Soc* 88:1; [vii] Armand M (1989) *Faraday Discuss Chem Soc* 88:65; [viii] Kulesza PJ, Cox JA (1998) *Electroanalysis* 10:73

PK, AL

Soliton — Solitons (solitary waves) are neutral or charged quasiparticles which were introduced in solid state physics in order to describe the electron–phonon coupling. In one-dimensional chainlike structures there is a strong coupling of the electronic states to conformational excitations (solitons), therefore, the concept of soliton (→ *polaron*, → *bipolaron*) became an essential tool to explain the behavior of → *conducting polymers*. While in traditional three-dimensional → *semiconductors* due to their rigid structure the conventional concept of → *electrons* and → *holes* as dominant excitations is considered, in the case of polymers the dominant “electronic” excitations are inherently coupled to chain distortions [i].

There are neutral solitons (radicals) with spin 1/2 and charged solitons (cations or anions) which carry no spin [ii]. The model calculations on the defect states induced upon → “*doping*” provide a description of the electronic properties of the polymer semiconductors, and make the theoretical evaluation of the spectral and conductivity data possible.

Refs.: [i] Heeger AJ (1986) *Polyacetylene: new concepts and new phenomena*. In: Skotheim TA (Ed) *Handbook of conducting polymers*, vol. 2. Marcel Dekker, New York, p 789; [ii] Chance RR, Boundreaux DS, Brédas J-L, Silbey R (1986) *Solitons, polarons, and bipolarons in conjugated polymers*. In: Skotheim TA (Ed) *Handbook of conducting polymers*, vol. 2. Marcel Dekker, New York, p 825

GI

Sollner (Söllner), Karl



(Courtesy of Barbara Sollner-Webb, Baltimore)

(Jan. 9, 1903, Vienna, Austria – June 14, 1986, Chevy Chase, Maryland, USA) Sollner received his Ph.D. in

chemistry in 1926 from the University of Vienna. From 1927 to 1933 he worked with → *Freundlich* at the Kaiser-Wilhelm Institute, Berlin, which was led by → *Haber*. Because of his Jewish mother, he faced problems after the takeover of the Nazis, and only by intervention of → *Nernst*, *Haber*, and → *Planck* he was granted the coveted title of 'Privatdozent'; however, the Nazis did not allow him to teach at the University. Thus later in 1933, when *Haber* and *Freundlich* were forced to resign from their positions by the Nazi regime, he and *Freundlich* were able to emigrate to England and work at the University College of London, where they were invited by → *Donnan* [i]. In 1937, he moved to the US, staying the first year at Cornell University, Ithaca; next he became Professor at the University of Minnesota Medical School, Minneapolis, and then in 1947 he joined the NIH, Bethesda, where he remained Chief of the Section on Electrochemistry and Colloid Physics until his death. *Sollner* made lasting contributions to the understanding of → *membranes* [ii] and colloidal solutions, including anomalous → *osmosis* [iii–v], he pioneered and coined the term → *permselectivity* [vi, vii], and he studied mosaic membranes [viii, ix]. His research helped in the development of → *membrane electrodes*, → *electrodialysis*, and artificial kidney membranes.

Refs.: [i] *Donnan FG (1942) Obituary Notices of Fellows of the Royal Society* 4:27; [ii] *Sollner K, Dray S, Grim E, Neihof R (1954) Electrochemical studies with model membranes. In: Clark HT, Nachmansohn D (eds) Ion transport across membranes. Academic Press, New York*; [iii] *Söllner K (1930) Z Elektrochem* 36:36, 234; [iv] *Söllner K (1930) Z Elektrochem* 36:234; [v] *Grim E, Sollner K (1960) J Gen Physiol* 44:381; [vi] *Carr CW, Sollner K (1944) J Gen Physiology* 28:119; [vii] *Carr CW, Sollner K (1945) J Gen Physiology* 28:179; [viii] *Söllner K (1932) Biochem Z* 244:370; [ix] *Carr W, Sollner K (1964) Nature* 204:878

FS

Solubility product — is the equilibrium constant K_{sp} of dissolution of a salt. Solubility products can be determined by direct determination of the → *concentrations* of the dissolved salt, provided the activity constants are practically 1.0, or otherwise known. Solubility products can also be calculated from the standard → *Gibbs energies* of formation $\Delta_f G^\ominus$ of the species.

For a salt $M_m A_n$ undergoing the dissolution $M_m A_n \rightleftharpoons m M^{x+} + n A^{y-}$ (with $mx = ny$), the s.p. is $K_{M_m A_n} = a_{M^{x+}}^m a_{A^{y-}}^n$ (a denote activities). The solubility (saturation concentration) $S_{M_m A_n}$ follows as $S_{M_m A_n} = \sqrt[m+n]{\frac{K_{M_m A_n}}{m^m n^n}}$, provided that no → *side reactions* occur.

Refs.: [i] *Solubility product constants. In: Lide DR (ed) (2003) The CRC handbook of chemistry and physics, 84th edn. 2003–2004. CRC Press, Boca Raton, pp 8–118 ff*; [ii] *Dean JA (1992) Lange's handbook of chem-*

istry, 14th edn. McGraw-Hill, New York, pp 8-6–8-11; [iii] *Sillen LG, Martell AE (1964) Stability constants of metal–ion complexes (Special Publ. No. 17). The Chemical Society, London*

MHer

Solution IR drop → IR_u (*ohmic potential*) drop, → *IR drop compensation*, and → *Ohmic drop distortion*

Solvation — Solvation is the interaction between dissolved ions, molecules, or colloids and solvent molecules that results in the binding (association) with the solvent molecules. Solvation is primarily an ion–dipole interaction but → *van der Waals forces*, → *hydrogen bonds*, and/or specific chemical forces may also be involved. The → *free energy* of solvation is the responsible energy for dissolution of ionic solids and thus it has to over-compensate the lattice energy holding the particles together in the solid. In the dissolution of molecular solids or gases (potential → *electrolytes*) chemical reactions occur, but the solvation also contributes to the overall → *Gibbs energy* change of the process. The solvation phenomenon is the main reason for the existence of separate cations and anions in electrolyte solutions. When a liquid A is dissolved in a solvent B, and the molecules of A are solvated by B, the free energy of solvation of A by B has to compensate the attractive forces between the molecules of A in the pure liquid A; i.e., beside the → *mixing entropy* the energy gain of this interaction is the driving force of the dissolution process.

- (a) Solvation of ions and dipolar molecules: It manifests itself in several phenomena, for instance, the ions will move along with solvent molecules when an electric field is applied, i.e., forming a kinetic entity with them. The solvation energy depends on the radius and the → *charge number* of the ion as well as on the → *dipole moment* or → *polarizability* of the solvent molecule. In the → *Born's* theory of solvation the properties of the solvent are taken into account by using dielectric → *permittivity* of the solvent. The structure of solvent changes not only in the immediate vicinity of the ions (primary solvation sphere) but the ion–solvent interaction may also influence other solvent molecules (secondary solvation).

The interaction between dissolved ions and the dipole molecules of water in aqueous solutions is called → *hydration*. (See also → *Born equation*, → *Born–Haber cycle*, → *Born–Mayer equation*, → *hydrated ion*, → *hydration number*.)

- (b) Solvation of nonpolar molecules: When nonpolar molecules are solvated by a polar solvent (e.g., by

water), the latter acquires an ordered structure associated with a large increase in entropy (\rightarrow *iceberg structure*). Generally, this disfavors the dissolution and is the reason for the \rightarrow *hydrophobic effect* of such molecules, and for favoring the formation of separate phases (\rightarrow *micelles*, \rightarrow *vesicles*, \rightarrow *liposomes*, \rightarrow *membranes*).

Refs.: [i] Erdey-Grúz T (1974) *Transport processes in aqueous solutions*. Adam Hilger, London, p 441; [ii] Coetzee JF, Ritchie CD (1969) *Solute-solvent interactions*. Marcel Dekker, New York; [iii] Komorsky-Lovrić Š (2002) *Electrolytes*. In: Scholz F (ed) *Electroanalytical methods*. Springer, Berlin, p 289; [iv] Bockris JO'M, Reddy AKN (1998) *Modern electrochemistry: Ionics*, vol. 1. Plenum Press, New York; [v] Dogonadze RR, Kalman E, Kornyshev AA, Ulstrup J (eds) (1985-88) *The chemical physics of salvation*, 3. vols. Amsterdam, Elsevier

GI

Solvents — Solvents are the liquid components of solutions that are present in excess. \rightarrow *electrolyte solutions* are one of the components of \rightarrow *electrochemical cells*. The presence of free ions, namely, the electrical current carriers in the electrolyte solutions, is a necessary condition of their electrical \rightarrow *conductivity*. The solvent in the electrolyte solution should have high enough \rightarrow *dielectric constant* to ensure the \rightarrow *dissociation* of the dissolved electrolyte (salts, acids, or bases) to separate ions. In addition, the essential properties of the solvents for electrochemical applications are their electrochemical window, stability of electrodes in the solutions, as well as practical aspects: purifying, drying, safety, environmental acceptability, etc. Solvents for electrolyte preparation can be classified as aqueous and nonaqueous, protic and aprotic, organic and inorganic, ionic liquids, conventional solvent-electrolyte systems, etc. Every subgroup has its advantages and limitations as electrochemical media. For example, \rightarrow *water* is a highly polar solvent that dissolves a large variety of salts, thus forming electrolyte solutions with a high ionic conductivity. However, its \rightarrow *electrochemical window* is too narrow and it is highly reactive with a variety of compounds and elements of interest.

To the contrary, however, many of the nonaqueous solvents possess lower polarity and thus form electrolyte solutions with a lower conductivity, but have a wider electrochemical window than that of water. \rightarrow *nonaqueous solvents* have a wide application in \rightarrow *lithium batteries* (both primary and secondary).

Refs.: [i] Reichardt C (2003) *Solvents and solvent effects in organic chemistry*, 3rd edn. Wiley-VCH, Weinheim; [ii] Aurbach D (ed) (1999) *Nonaqueous electrochemistry*. Marcel Dekker, New York

DA, EM

Solvent effect — is a term used in relation to the kinetics of \rightarrow *electron transfer* or \rightarrow *proton transfer* to denote various effects of solvent nature (including qualitative). Despite of serious difficulties in separating various types of such effects, the \rightarrow *static solvent effect* and the \rightarrow *dynamic solvent effect* are typically discussed. In parallel with this classification going from various theories of the \rightarrow *charge transfer* of elementary act, more phenomenological gradation of solvent effects is widely accepted. It takes into account the changes of reaction kinetics when going from aprotic to protic solvents, as well as correlations with numerous \rightarrow *donor* and \rightarrow *acceptor numbers* [i]. Solvent effects in kinetics are closely related to purely thermodynamic aspects, namely the dependence of \rightarrow *equilibrium potential* of a certain \rightarrow *redox couple* on solvent nature. The impossibility to measure the difference of \rightarrow *equilibrium electrode potentials* in different solvents (see \rightarrow *absolute potential*) induces a basic problem for kinetics as well: it prevents the exact comparison of reaction rates in different solvents at constant \rightarrow *overpotential*.

Ref.: [i] Fawcett WR (2004) *Liquids, solutions, and interfaces*. Oxford University Press, New York

GT

Dynamic solvent effect — is a phenomenon typical for adiabatic \rightarrow *electron transfer* and \rightarrow *proton transfer* reactions. This effect is responsible for a dependence of the reaction rate on solvent relaxation parameters. The initial search for a dynamic solvent effect (conventionally assumed to be a feature of reaction adiabaticity) consisted in checking the viscosity effect. However, this approach can lead to controversial conclusions because the viscosity cannot be varied without changing the \rightarrow *permittivity*, i.e. a dynamic solvent effect cannot be unambiguously separated from a \rightarrow *static solvent effect* [i]. Typically a slower solvent relaxation goes along with a higher permittivity, and the interplay of the two solvents effects can easily look as if either of them is weaker. The problems of theoretical treatment of the dynamic solvent effect of solvents having several relaxation times are considered in refs. [ii-iii].

Refs.: [i] Nazmutdinov RR, Tsirlina GA, Manyurov IR, Bronshstein MD, Titova NV, Kuz'minova ZV (2006) *Chem Phys* 326:123; [ii] Sparpaglione M, Mukamel S (1988) *J Chem Phys* 88:4300; [iii] Zusman LD (1988) *Chem Phys* 119:51

GT

Static solvent effect — is widely understood as the dependence of \rightarrow *reaction rate* on solvent \rightarrow *permittivity*. The most systematic studies of this effect were stimulated by the early version of \rightarrow *Marcus theory* and mostly consisted in experimental verification of Mar-

cus formula for solvent (outersphere) reorganization energy. The permittivity-affected term in this formula is the Pekar factor ($1/\epsilon_{\text{op}} - 1/\epsilon_{\text{st}}$), where ϵ_{op} and ϵ_{st} are optical and static \rightarrow solvent permittivities. Verification of Marcus formula commonly concerns the experimental data on the charge-transfer rate constants for zero or low overvoltage and high supporting electrolyte concentrations, i.e., in the absence of beyond Marcus effects and electrostatic electrode-reactant interactions. In general (especially for diluted solutions and high electrode charge densities) solvent permittivity affects not exclusively the outersphere reorganization, but electrostatic work terms as well, resulting in the effects of the same or opposite sign. This interplay of two solvent-dependent terms in activation energy can lead to incorrect conclusions about the correctness of Marcus formula. The experimentally discovered deviations from this formula induced serious theoretical efforts to improve the models of solvation and solvent reorganization [i] and later attracted attention to the interplay of outer- and innersphere contributions to reorganization energy [ii].

Refs.: [i] German ED, Kuznetsov AM (1981) *Electrochim Acta* 26:1595; [ii] Kuznetsov AM, Ulstrup J (1999) *Electron transfer in chemistry and biology*. Wiley, Chichester

GT

Solvent permittivity — ϵ is an index of the ability of a solvent to attenuate the transmission of an electrostatic force. This quantity is also called the \rightarrow dielectric constant. \rightarrow permittivity decreases with field frequency. Static (related to infinite frequency) and optical ϵ_{op} (related to optical frequencies) permittivities are used in numerous models evaluating the solvation of ions in polar solvents under both static and dynamic conditions. Usually the refractive index n is used instead of ϵ_{op} ($n^2 = \epsilon_{\text{op}}$), as these quantities are available for the majority of solvents. The theory of permittivity was first proposed by \rightarrow Debye [i]. Systematic description of further development can be found in the monograph of Fröhlich [ii]. Various aspects of application to reactions in polar media and solution properties, as well as tabulated values can be found in Fawcett's textbook [iii].

See also \rightarrow Debye–Clausius–Mossotti equation, \rightarrow Debye–Hückel–Onsager equation, \rightarrow dielectric relaxation.

Refs.: [i] Debye P (1929) *Polar molecules*. Chemical Catalog, New York; [ii] Fröhlich H (1949) *Theory of dielectrics*. Oxford University Press, London; [iii] Fawcett WR (2004) *Liquids, solutions, and interfaces*. Oxford University Press, New York

GT

Solvent 'polarity' parameters — use solvatochromic dyes (dyes whose electronic transitions are strongly dependent on the nature of the solvent) as indicators of solvent polarity. A comprehensive solvent polarity scale was first proposed by Kosower who defined the polarity parameter, Z , as the molar transition energy, E_{T} , for the charge transfer band of 1-ethyl-(methoxycarbonyl)pyridinium iodide in a given solvent as

$$E_{\text{T}} (\text{kcal mol}^{-1}) = hc\tilde{\nu}N_{\text{A}} = 2.859 \times 10^{-3}\tilde{\nu} (\text{cm}^{-1}) \\ \equiv Z (\text{kcal mol}^{-1})$$

or

$$E_{\text{T}} (\text{kJ mol}^{-1}) = 1.196 \times 10^{-2}\tilde{\nu} (\text{cm}^{-1}) \\ \equiv Z (\text{kJ mol}^{-1}),$$

where h is the \rightarrow Planck constant, c is the velocity of light, $\tilde{\nu}$ is the wavenumber of the photon producing the electronic excitation, and N_{A} is the Avogadro constant. For instance, a Z value of 83.6 for methanol means that transition energy of 83.6 kcal is necessary to promote one mole of the standard dye, dissolved in methanol, from its electronic ground state to its first excited state. The Z scale covers a range from 60 kcal mol $^{-1}$ for *i*-octane to ca. 94.6 kcal mol $^{-1}$ for water. The higher the Z value, the higher is solvent polarity. This is because the stronger the stabilizing effect of the solvent on the ground-state ion pair (as compared with the less dipolar radical pair in the excited state), the higher this energy is and, thus, the Z value.

Then, Dimroth and Reichardt proposed a solvent polarity parameter, $E_{\text{T}}(30)$, based on transition energy for the longest-wavelength solvatochromic absorption band of the pyridinium *N*-phenolate betaine dye, which is dye No. 30 in a table constructed by these authors. The $E_{\text{T}}(30)$ values have been determined for more than 360 pure organic solvents and many binary solvent mixtures.

Recently, the use of a scale of normalized E_{T}^{N} values has been recommended. Water and tetramethylsilane (TMS) are used as extreme reference solvents in this scale.

$$E_{\text{T}}^{\text{N}} = \frac{E_{\text{T}}(\text{solvent}) - E_{\text{T}}(\text{TMS})}{E_{\text{T}}(\text{water}) - E_{\text{T}}(\text{TMS})} = \frac{E_{\text{T}}(\text{solvent}) - 30.7}{32.4}.$$

Hence, the E_{T}^{N} scale ranges from 0.000 for TMS, the least polar solvent, to 1.000 for water, the most polar solvent.

Depending on their specific solvent–solute interactions, solvents can generally be divided into three major groups according to their $E_{\text{T}}(30)$ and E_{T}^{N} values:

(1) apolar non-hydrogen bond donor (non-HBD) solvents, $0.0 < E_T^N < 0.3$, (2) dipolar (non-HBD) solvents, $0.3 < E_T^N < 0.5$, and (3) protic hydrogen bond donor (HBD) solvents $0.5 < E_T^N < 1.0$.

Refs.: [i] Kosower EM (1968) *An introduction to physical organic chemistry*. Wiley, New York, p 238; [ii] Dimroth K, Reichardt C, Siepmann T, Bohlmann F (1963) *Liebigs Ann Chem* 661:1; [iii] Reichardt C, Harbusch-Goernert (1983) *Liebigs Ann Chem* 721; [iv] Reichardt C (2003) *Solvents and solvent effects in organic chemistry*, 3rd edn. Wiley-VCH, Weinheim, p 411

WK

Solvophobicity — The effect that a relative unfavorable solvation free energy leads to solute aggregation. See → *hydrophobic effect*.

Ref.: [i] Lazarides T (2001) *Acc Chem Res* 34:931

FS

Somogyi, Zoltán — (1915, Budapest, Hungary (Austro-Hungarian Empire) – 1945, Budapest, Hungary) Earned his M.Sc. and Ph.D. degrees from the University of Budapest. After receiving his degree he joined the group of → *Szebellédy*. They invented the coulometric analysis (titration) in 1938 (→ *coulometry*, → *coulometric titration*).

Ref.: [i] Szebellédy L, Somogyi Z (1938) *Fresenius Z Anal Chem* 112:313, 323, 385, 391, 395, 400

GI

Sonoelectrochemistry — The term sonoelectrochemistry refers to the use of ultrasound in electrochemical processes. Early work by Moriguchi [i] suggested that → *mass transport* and → *depolarization* effects are possible. Yeager [ii] further developed the technique and surveyed potential applications. For example, it is a convenient method of agitation in coulometric cells of small volume [iii]. More recently new and more powerful instrumentation has become available and applications in → *electrosynthesis* [iii] and in → *electroanalysis* [iv] have been developed. High amplitude → *ultrasound* waves in liquid media create conditions where very strong agitation and cavitation bubble oscillations are observed. Very high amplitudes can be achieved with immersion horn transducers placed close to the electrode surface. Very high rates of mass transport can be achieved and cleaning of electrodes in situ during operation is possible.

Refs.: [i] Moriguchi N (1934) *J Chem Soc Jpn* 55:751; [ii] Yeager E (1953) *J Acoust Soc Am* 25:443; [iii] Bard AJ (1963) *Anal Chem* 35:1125; [iv] Walton DJ (1996) *Adv Sonochem* 4:205; [v] Compton RG, Eklund JC, Marken F (1997) *Electroanalysis* 9:509

FM

Sørensen, Søren Peter Lauritz



(Courtesy of Oesper Collection, University of Cincinnati)

(Jan. 9, 1868, Havrebjerg, Denmark – Feb. 12, 1939, Charlottenlund, Denmark) Sørensen suggested a convenient way of expressing acidity [i–iv] – the negative logarithm of hydrogen ion concentration: $\text{pH} = -\log[\text{H}^+]$. The letters → *pH* are an abbreviation for “pondus hydrogenii” (translated as potential of hydrogen). “*p*-functions” have also been adopted for other concentrations and concentration-related numbers. For example, “ $\text{pCa} = 5.0$ ” means a concentration of calcium ions equal to 10^{-5} M, and $\text{pK}_a = 4.0$ means an acid dissociation constant equal to 10^{-4} . Sørensen popularized the artificial → *buffer* solutions proposed by → *Szily* to maintain constant pH of solutions (see also → *Henderson, L.J.*, and → *Hasselbalch*).

Refs.: [i] Sørensen SE (1909) *Prozessen Biochem Zeit* 21:131; [ii] Hills AG (1972) *Science* 176:459; [iii] Jensen WB (2004) *J Chem Educ* 81:21; [iv] Clarke WM (1928) *The determination of hydrogen ions*, 3rd edn. Williams and Wilkins, Baltimore

EK

Sørensen value — Obsolete term for the numerical value of → *pH*. Sørensen used the term ‘→ *hydrogen ion exponent*’ for pH.

Ref.: [i] Clark WM (1928) *The determination of hydrogen ions*, 3rd edn. Williams and Wilkins, Baltimore, p 37

FS

Soret effect — When a temperature gradient is applied to an homogeneous mixture of two or more components there is a partial separation of the components by → *migration* along the temperature gradient. This phenomenon, known as Soret effect, occurs in condensed phases (i.e., liquids and solids) [i]. Another term that is used to describe the Soret effect is **thermodiffusion**, which has been observed for either mixtures of gases or liquids and solid solutions [ii]. For electrolytic solutions in a temperature gradient, ions move from a location

with higher temperature to another one with lower temperature. The concentration gradient in the solution increases until the thermodiffusion and the normal \rightarrow *diffusion* counterbalance each other reaching a stationary steady state. By taking into consideration the three driving forces for an ion i (i.e., temperature, \rightarrow *chemical potential* and \rightarrow *potential* gradients for thermodiffusion, diffusion, and migration, respectively) it is possible to deduce the following expression:

$$z_i F \nabla E + (\nabla \mu_i)_{T,P} + \frac{Q_i^*}{T} \nabla T = 0,$$

the first term representing the driving force due to the electric field, the second one corresponding to chemical potential differences, and the third one to the thermodiffusion. Q_i^* is the \rightarrow *heat of transport*. The process convers to the Soret effect has the name Dufour effect.

Refs.: [i] Agar JN (1963) *Thermogalvanic cells*. In: Delahay P (ed) *Advances in electrochemistry and electrochemical engineering*, vol. 3. Interscience, New York, pp 31–121; [ii] Lange E, Göhr H (1962) *Thermodynamische Elektrochemie*. Hüthig, Heidelberg; [iii] Newman J, Thomas-Alyea KE (2004) *Electrochemical systems*, 3rd edn. Wiley Interscience, Hoboken, pp 317

MBS

Space charge layer (region) \rightarrow *electrode materials*, subentry \rightarrow *semiconductor electrodes*, \rightarrow *Schottky barrier*, \rightarrow *semiconductor*, \rightarrow *silicon electrochemistry*

Specific adsorption \rightarrow *adsorption*

Specific conductance \rightarrow *conductance*

Specificity — The ability to assess unequivocally the \rightarrow *analyte* in the presence of other components that may be expected to be present in a \rightarrow *sample* [i].

Ref.: [i] Skoog D, West D, Holler F (1996) *Fundamentals of analytical chemistry*. Saunders College Publishing, New York

FG

Spectroelectrochemistry — Many \rightarrow *electrode processes* are complex and difficult to study quantitatively and unambiguously. The current signal from voltammetric experiments provides only very limited structural information about reaction intermediates at surfaces or in solution. In order to improve the level of quantitative and structural information available from electrochemical experiments, spectroscopic techniques are directly (or “in situ”) coupled to electrochemical methods [i, ii].

In situ Electrochemical \rightarrow *Electron Spin Resonance* (EESR) [iii]

In situ UV/Vis/NIR Optical Spectroelectrochemistry [iv]

In situ Luminescence Spectroelectrochemistry [v]

In situ Electrochemical Nuclear Magnetic Resonance Spectroscopy (ENMR) [vi]

In situ Surface Enhanced Raman Spectroelectrochemistry (SERS) [vii]

In situ Electrochemical X-ray Diffraction (XRD) and Synchrotron Techniques [viii]

In situ Mössbauer Spectroelectrochemistry [ix]

In situ Spectroellipsometry [x]

In situ Nonlinear Optical Methods and Second Harmonic Generation [xi]

In situ Diffuse Reflection Spectroscopy [xii]

Refs.: [i] Gale RJ (1988) *Spectroelectrochemistry – theory and practice*. Plenum Press, New York; [ii] Neudeck A, Marken F, Compton RG (2000) *UV/Vis/NIR Spectroelectrochemistry*. In: Scholz F (ed) *Electroanalytical methods*. Springer, Berlin, p 167f; [iii] Compton RG, Waller AM (1988) *ESR spectroscopy of electrode processes*. In: Gale RJ (ed) *Spectroelectrochemistry – theory and practice*. Plenum Press, New York, p 349f; [iv] Hamann CH, Hamnett A, Vielstich W (1998) *Electrochemistry*. Wiley, New York, p 247; [v] Collinson MM, Wightman RM (1995) *Science* 268:1883; [vi] Tong YY, Rice C, Wieckowski A, Oldfield E (2000) *J Am Chem Soc* 122:1123; [vii] Mrozek MF, Weaver MJ (2000) *J Am Chem Soc* 122:150; [viii] McBreen J (1995) *In situ synchrotron techniques in electrochemistry*. In: Rubinstein I (ed) *Physical electrochemistry*. Marcel Dekker, New York, p 339f; [ix] Scherson DA (1991) *Mossbauer spectroscopy*. In: Abruna HD (ed) *Electrochemical interfaces*. VCH, Weinheim, p 413; [x] Gottesfeld S, Kim YT, Redondo A (1995) *Recent application of ellipsometry and spectroellipsometry in electrochemical systems*. In: Rubinstein I (ed) *Physical electrochemistry*. Marcel Dekker, New York, p 393f; [xi] Richmond GL (1991) *Investigations of electrochemical interfaces by nonlinear optical methods*. In: Abruna HD (ed) *Electrochemical interfaces*. VCH, Weinheim, pp 267; [xii] Schröder U, Scholz F (1997) *J Solid State Electrochem* 1:62

FM

Spectroelectrochemistry, reflection mode — The interaction of electromagnetic radiation with matter (\rightarrow *spectroscopy*) may occur by absorption or scattering when radiation impinges on matter or passes through matter. In the latter case (transmission mode) the radiation before and after passage is evaluated in order to obtain the desired spectrum. In studies of opaque materials or of surfaces interacting with matter inside the (bulk)

sample this is impossible or undesirable. Radiation reflected from the surface can carry the required information because during reflection the interaction between radiation and matter may cause similar changes of the impinging radiation as during transmission. In a typical spectroelectrochemical reflection mode experiment light is guided to the metal/solution interface of an electrode, the reflected beam contains information about the interface as well as the interphase.

Ref.: [i] Holze R (2008) *Surface and interface analysis: an electrochemists toolbox*. Springer, Berlin

RH

Spectroelectrochemistry, single molecule — (SMS-EC) Detection of electron transfer processes at luminescing single molecules by noting the quenching effects of electron transfer, for example in the oxidation of polymer molecules [i].

Ref.: [i] Palacios R, Fan F-RF, Bard AJ, Barbara PF (2006) *J Am Chem Soc* 128:9028

AJB

S

Spectroellipsometry — In \rightarrow *ellipsometry* the optical properties of the interphase are most frequently studied only at a single wavelength or at selected wavelengths. Measurements of the complex optical parameters as a function of continuously varied wavelength are called spectroellipsometry.

Ref.: [i] Holze R (2008) *Surface and interface analysis: an electrochemists toolbox*. Springer, Berlin

RH

Spectrometer — Spectrometers are instruments to record spectra, i.e., intensity (or absorbance) versus wavelength or versus frequency of electromagnetic radiation. The interaction of matter with electromagnetic radiation can be studied in absorption or in emission mode. In the former case electromagnetic radiation (used as probe) is interacting with matter. (The term **spectroscope** refers to the early instruments where the spectra were observed with the eye. Although in all modern experiments the spectra are measured and recorded, the term spectroscope is still used synonymously to **spectrometer**.)

Spectrometers can be divided into two groups: (a) scanning spectrometers, where the frequency (wavelength) of the radiation is continuously scanned and the radiation is simultaneously measured, and (b) Fourier spectrometer, where all frequencies (wavelengths) are modulated by an interferometer, and simultaneously detected. The interferogram is Fourier transformed to generate the spectrum. Scanning spectrometers are usually

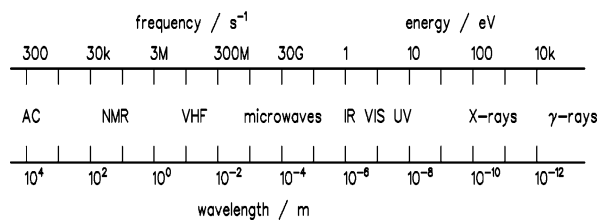

Spectrometer — **Figure**. The electromagnetic spectrum (approximate values and numbers only) with typical applications

built of a monochromator, a cuvette, a detector, optical parts to guide the radiation, and electronics for data processing. Some spectrometers have polychromators, i.e., a light dispersing element and a multichannel detector instead of the monochromator and single channel detector (\rightarrow *spectrometer, diode array*).

RH

Spectrometer, diode array — In the basic design of most \rightarrow *spectrometers* the electromagnetic radiation of the source is sent to the sample. After interaction with the sample (e.g., by absorption of some radiation at specific frequencies) the radiation is sent to the detector. In order to analyze the dependency of the extent of the interaction (i.e., the actual absorption) the signal must be analyzed as a function of its energy by applying dispersive elements (like e.g., prisms or gratings). In early designs the dispersive element is operated in a mode permitting only radiation of a single energy (or a very narrow range of energies, details are described by the term spectral resolution) is allowed to reach the detector. The whole spectrum is recorded by repeating this procedure for every energy in the studied range. The advent of very small and very sensitive optical detectors (photodiodes, charge-coupled devices, etc.) which could be placed at the exit of the dispersive element corresponding to specific energies enables simultaneous recording of intensities at several energies at the same time. Arrays of numerous detector elements (e.g., 1024 elements in a typical diode array) allow recording of a UV-Vis-spectrum in the range $190 < \lambda < 1100$ nm at the same time. Drawbacks are the limited resolution given by the size and spacing of detector elements in the array (better than 0.5 nm are currently impossible), a slightly worse stray light rejection (when compared with scanning instruments), and the illumination of the sample with light of all investigated frequencies (“white light”) conceivably resulting in photochemical processes.

Ref.: [i] Owen T (1996) *Fundamentals of modern UV-visible spectroscopy*. Böblingen

RH

Spectrometry → spectroscopy

Spectromicroscopy — Spectroscopic investigations performed in a spatially (locally) resolved manner on a micrometer scale mostly employing a specifically adapted microscope (see also → *spectroscopy*).

RH

Spectroscopy (spectrometry) — Plethora of techniques used to study the interaction of energy, especially of electromagnetic radiation, with matter, or analyzing electromagnetic radiation (or particles) emitted by matter. The term is also used in cases where ions that were accelerated in vacuum are analyzed according to their mass-to-charge ratio (mass spectrometry). All spectroscopic techniques have in common that so-called spectra are recorded, i.e., functions characterizing the interaction of electromagnetic waves with the matter (transmission, absorption), the intensity of emitted electromagnetic waves or particles as a function of energy. The term **spectroscopy** refers to the early experiments where the spectra were observed with the eye. Although in all modern experiments the spectra are measured and recorded, the term spectroscopy is still used synonymously to **spectrometry**.

The combination of spectrometry with a microscopy enables spatially (locally) resolved measurements, depending on the scale of resolution the method is termed → *spectromicroscopy*. The in situ combination of spectrometry with electrochemistry is called → *spectro-electrochemistry*. Note that while most forms of spectroscopy involve the interaction of electromagnetic radiation with a system, the term is also used at times in a more general sense as in → *electrochemical impedance spectroscopy*.

RH

Confocal Raman spectroscopy — In a confocal optical arrangement, light coming from the surface/interface under investigation is collected and guided by suitable (e.g., microscopy) objectives towards an optical detector (e.g., a photomultiplier or photodiode) or a spectrometer with a detector. A pinhole is placed in front of this detector/monochromator. Properly located this pinhole will only allow light to pass from the focal point on the surface, all other light being “out of focus” will be rejected. By scanning the surface in *x*- and *y*-direction and storing the optical information (e.g., scattered light intensity, Raman spectra) an image of the surface can be generated [i–iii]. Illumination of the investigated surface can be achieved in various ways, this of course includes monochrome laser light.

In this case, laser light is focused with suitable lenses to a diffraction-limited spot. For reviews on instrumentation and application see [iv, v]. A typical experimental setup is depicted below.

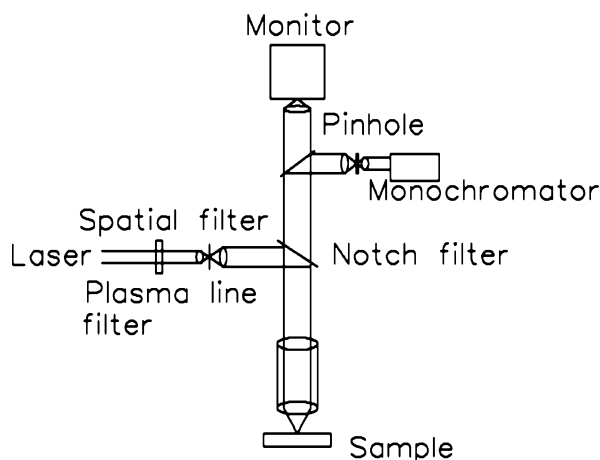

Spectroscopy (spectrometry) — Confocal Raman spectroscopy — Figure

Refs.: [i] Minsky M (1988) *Scanning* 10:128; [ii] Wilson T, Shepard CJR (1984) *Scanning optical microscopy*. Academic Press, London; [iii] Corle TG, Kino GS (1996) *Confocal scanning optical microscopy and related techniques*. Academic Press, New York; [iv] Delhaye M, Barbillat J, Aubard J, Bridoux M, Da Silva E (1996) *Instrumentation*. In: Rurrell G, Corset J (eds) *Raman microscopy: developments and applications*. Academic Press, San Diego; [v] Ren B, Lin XF, Jiang YX, Cao PG, Xie Y, Huang QJ, Tian ZQ (2003) *Appl Spectrosc* 57:419

RH

Diffuse reflection spectroscopy — Interaction of matter with electromagnetic radiation by absorption of radiation can experimentally be achieved by transmission (i.e., the beam of radiation passes through the system under investigation and is attenuated in a way resulting in a signal providing the desired spectrum) or by reflection. In the latter case, the reflected beam is also attenuated, its analysis provides a spectrum. Besides external (specular) reflection wherein the angle of incidence and the angle of reflection are exactly equal and attenuated total reflection (ATR) diffuse reflection can be employed for studies of powder samples or rough surfaces. In the latter case, the incident beam is directed at the sample (or system under investigation). The light diffusely reflected from the surface is not directed in any defined angle like in specular reflectance, instead it is more or less scattered. With suitable optics a fraction of this reflected light is collected and guided to the detector resulting finally in a spectrum [i, ii]. Applications in UV-Vis spectroelectrochemistry have been reported [iii].

Refs.: [i] Gauglitz G, Vo-Dinh T (eds) (2003) *Handbook of spectroscopy*. Wiley-VCH, Weinheim; [ii] Kortüm G (1969) *Reflexionspektroskopie*, Springer, Berlin; [iii] Holze R (2008) *Surface and interface analysis: an electrochemists toolbox*. Springer, Berlin

Electron spin resonance (ESR) spectroscopy —

Paramagnetic species, e.g., molecular radicals and certain transition metal ions, will assume one of two possible orientations with respect to an external magnetic field when exposed to this field. The energy difference between both states is small (typically at $T = 300\text{ K}$ and a magnetic flux density $B = 0.3\text{ T}$: $\Delta E = 5.57 \times 10^{-24}\text{ J}$) and consequently population of both states is very similar (ratio $n_{s,\text{high}}/n_{s,\text{low}} = 0.99866$). When atoms with a non-zero nuclear spin are located close to the electron their magnetic field will be vectorially added to the external field thus creating further energetic states for the electron. Transitions between the states are possible by supplying electromagnetic radiation of suitable energy (in the given example in the microwave range around 10 GHz). Studies of the possible transition and the obtained spectral patterns provide information about the molecular structure of the studied radical

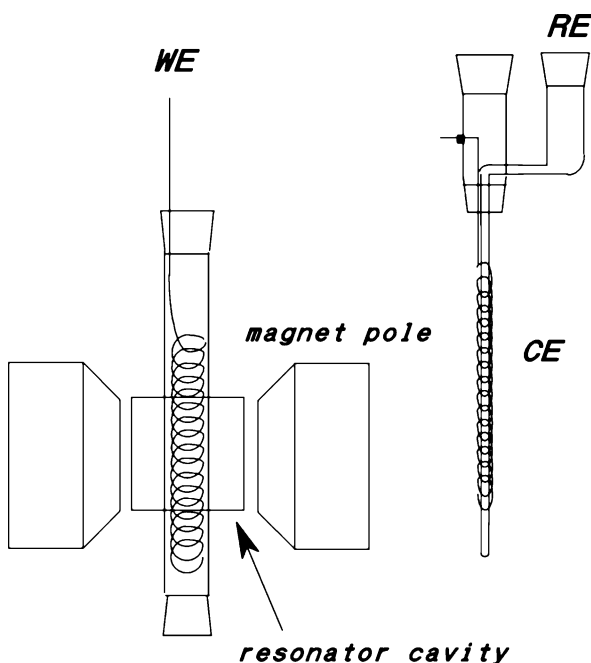

Spectroscopy (spectrometry) — Electron spin resonance (ESR) spectroscopy — Figure. WE working electrode, CE counter electrode, RE reference electrode; the reference and counter electrode assembly is placed inside the quartz tube with the working electrode, this assembly is placed inside a resonator cavity mounted between the poles of the magnet

etc. The method has been successfully applied to electrochemical in situ studies [i–iv], a typical cell is shown in the figure.

Refs.: [i] Holze R (2008) *Surface and interface analysis: an electrochemists toolbox*. Springer, Berlin; [ii] Holze R (2003) *Rec Res Devel Electrochem* 6:101; [iii] Compton RG, Waller AM (1988) *ESR spectroscopy of electrode processes*. In: Gale RJ (ed) *Spectroelectrochemistry*. Plenum Press, New York, p 349; [iv] Bagchi RN, Bond AM, Scholz F (1989) *Electroanalysis* 1:1

RH

Infrared spectroscopy — is employed mostly in chemical analysis for elucidation of molecular structures. Based on typical vibrational bands structural features of molecules can be identified. This helps in identifying the species in question. Infrared spectroscopy is used in spectroelectrochemical studies to obtain structural information related to electrochemical \rightarrow *interfaces* and \rightarrow *interphases*. In addition it is used to detect and identify species in the solution phase. The methodical approaches basically resemble those of \rightarrow *UV-Vis spectroscopy*. For studies of species in solution, transmission arrangements with optically transparent, minigrad, or similar electrodes are used. Bulk, opaque electrodes can be used in an external reflection arrangement wherein the infrared light passes through the electrolyte solution under investigation and is reflected back through the solution towards the detector. Adsorbates can be studied in the external reflection mode or with an attenuated total reflectance arrangement. Surface selection rules describing the interaction between the electric field of electromagnetic radiation impinging on an electronically conductive (metal) surface are employed in evaluation of the spectra. Changes of infrared-active dipole moments of the surface-adsorbate arrangement will absorb radiation only from *p*-polarized radiation. This fact is utilized in obtaining the necessary sensitivity. Because of the strong infrared absorption of most solvents the actual infrared absorption of interfacial species amounts to only a very minor fraction of the overall absorption. By either modulating the plane of polarization of the employed (polarized) infrared light (between *s*- and *p*-polarized) or by modulating the electrode potential the required sensitivity and the desired suppression of absorption by the solvent are achieved.

Ref.: [i] Holze R (2008) *Surface and interface analysis: an electrochemists toolbox*. Springer, Berlin

RH

Luminescence spectroscopy — Luminescence is the emission of electromagnetic radiation, in particular, light in the visible range of the electromagnetic spectrum, effected by a supply of energy. Numerous forms

of luminescence caused by a host of different forms of energy have been observed. Chemiluminescence is the emission of light by energetically excited species formed in the course of a chemical reaction. The reacting species may be radicals, ions, or other energetic species generated by e.g., \rightarrow *electrolysis*. In this case it may be called more specifically \rightarrow *electrochemiluminescence* ECL. Photoluminescence is caused by the absorption of light. When emission of light (luminescence) follows rapidly after absorption the phenomenon is generally called fluorescence, delayed emission is called phosphorescence. Luminescence spectroscopy can be employed to identify reaction intermediates and products, its intensity may be used to monitor the progress of an electrode reaction.

Ref.: [i] Holze R (2008) *Surface and interface analysis: an electrochemists toolbox*. Springer, Berlin

RH

Mößbauer (Mössbauer) spectroscopy — The energy of a gamma quantum emitted or absorbed by an atomic nucleus differs usually somewhat because of recoil and Doppler-broadening induced by thermal movement. At room temperature the value differs by about 10^{-2} to 10 eV from the true energy value $h\nu_0$ of the nuclear transition. The recoil energy E_R and the corresponding momentum p are

$$E_R = p^2 / (2M) = (h\nu_0)^2 / (2Mc^2)$$

with M the nuclear mass. An emitted nuclear quantum has the energy

$$h\nu = h\nu_0 - E_R,$$

whereas for absorption the quantum needs to have the energy

$$h\nu = h\nu_0 + E_R.$$

Emission and absorption line differ consequently by $2E_R$ (≈ 1 eV as a typical value). Since nuclear transition energies are very narrow (10^{-10} to 10^{-4} eV) resonant absorption is only possible if the lacking energy is supplied by some means. With freely moving species this can be achieved by the Doppler-effect, e.g., in an ultracentrifuge. When the involved atom is part of a rigid crystalline structure the recoil is transferred to the crystal instead of to the single atom. Because the mass of the crystal is much larger than the mass of the atom the recoil energy as well as the Doppler shift practically disappear to about 10 meV being in the same order of magnitude as the phonons in the crystal lattice (Mößbauer effect). The corresponding gamma line (sometimes also called Mössbauer line) shows only the natural linewidth (5×10^{-13} eV for ^{57}Fe ; 5×10^{-16} eV for ^{67}Zn),

its linewidth is reduced by about five orders of magnitude. Because of the extremely narrow linewidth resonance conditions might be lost already if source or absorber crystal are moving even at low speed (fractions of mm/s). This provides a simple possibility to measure shifts of the line induced by other influences. Measuring such a shift requires simply to move the source or the absorber at a well-defined acceleration and look for resonant absorption. Consequently, the resulting Mössbauer spectra are usually displayed with the gamma transmission of the sample vs. the velocity of the source. In the emission mode the intensity is displayed as a function of the speed. Shifts of the absorption line can be induced by changes in the electron density around the atomic nucleus. These changes can be effected by filled inner-core orbitals and partially filled valence orbitals; they are called isomer shifts. The change influences both the ground state and the excited state; in sum a change of the absorption energy is observed.

This shift is indicative of, e.g., the nature of the chemical bond between the investigated atom and its neighbors or the state of oxidation. The various parameters, observables and properties are collected in the Table below.

Spectroscopy (spectrometry) — Mößbauer (Mössbauer) spectroscopy — Table

Mößbauer parameter	Observed quantity	Obtained information
Isomer shift	Charge density at nucleus	Valence state
Quadrupole splitting	Electric field gradient at nucleus	Symmetry of charge Environment
Magnetic splitting	Magnetic field at nucleus	Magnetic ordering Particle size

Applications employing specifically designed cells involve Mössbauer-active nuclei (^{119}Sn , ^{57}Fe , ^{57}Co) in fuel cell electrodes, corroding surface, transition metal complexes etc. [i–iii].

Refs.: [i] Scherson DA (1988) *Mößbauer spectroscopy*. In: Gale RJ (ed) *Spectroelectrochemistry*. Plenum Press, New York, p 399; [ii] Eldridge JL, O'Grady WE (1991) *Mößbauer spectroscopy*. In: Varma R, Selman JR (eds) *Techniques for characterization of electrodes and electrochemical processes*. Wiley, New York, p 343; [iii] Holze R (2007) *Surface and interface analysis: an electrochemists toolbox*. Springer, Berlin

RH

NIR (near infra red) spectroscopy — Besides optical absorption in the UV-Vis region of the electromagnetic spectrum, absorption in the near infrared region can be employed to study electrochemical processes. This part of the electromagnetic spec-

trum between ca. 900 and 3000 nm ($10,000\text{ cm}^{-1}$ to 3333 cm^{-1}) shows predominantly overtone bands of electronic absorptions already seen in the UV-Vis region. In addition, absorptions caused by, e.g., mobile charge carriers are seen. Thus this part of the spectrum has not attracted much attention. Investigations of intrinsically conducting polymers and transition metal complexes showing large absorptions in the NIR because of intramolecular charge transfers have caused an increased interest in NIR spectroelectrochemistry [i]. For an introductory overview see [ii, iii].

Refs.: [i] Holze R (2008) *Surface and interface analysis: an electrochemists toolbox*. Springer, Berlin; [ii] Holze R (2004) *J Solid State Electrochem* 8:982; [iii] Abd-Elwahed A, Holze R (2003) *Curr Top Electrochem* 9:93

RH

Nonlinear optical methods of spectroscopy

— Illumination of a surface or interface with poly- or monochromatic light of very high intensity can result in nonlinear optical phenomena like, e.g., generation of light with the \rightarrow *second harmonic* (SHG) or third harmonic (THG) of the incoming frequency or in sum or difference frequency generation (SFG or DFG). For general reviews including theoretical considerations see [i–vi]. Surface second harmonic generation SHG is more simple and versatile whereas sum-frequency generation SFG is more powerful as it allows identification of adsorbed species at the interface via their vibrational resonances.

Refs.: [i] Holze R (2008) *Surface and interface analysis: an electrochemists toolbox*. Springer, Berlin; [ii] Tadjeddine A, Peremans A (1998) *Non-linear optical spectroscopy of the electrochemical interface*. In: Clark RJH, Hester RE (eds) *Advances in spectroscopy (spectroscopy for surface science)*, vol. 26. Wiley, Chichester, p 159; [iii] Shen YR (1990) *In: Gutiérrez C, Melendres C (eds) Spectroscopic and diffraction techniques in interfacial electrochemistry (NATO ASI series C, vol. 320)*. Kluwer, Dordrecht, p 281; [iv] Shen YR (1986) *Applications of optical second-harmonic generation to surface science*. In: Hall RB, Ellis AB (eds) *Chemistry and structure at interfaces*. VCH, Deerfield Beach, p 151; [v] Williams CT, Beattie DA (2002) *Surf Sci* 500:545

RH

Nuclear magnetic resonance (NMR) spectroscopy — Nuclear magnetic resonance (NMR) spectroscopy of atoms having a nonzero spin (like, e.g., H, ^{13}C) is an extremely powerful tool in structural investigations in organic and inorganic chemistry. Beyond structural studies atoms observable with NMR can also be used as probes of their environment. Thus NMR may be employed for *in situ* spectroelectrochemical studies [i]. Cell designs for *in situ* NMR spectroscopy with electrochemical cells are scant. Because of the low sensi-

tivity, designs with working electrodes having large active surface areas (powder electrodes, metal coated inert supports like, e.g., silica or alumina) have been described [ii, iii]. This is a result of the fact that in a typical NMR experiment about 10^{19} spins are required. Assuming 10^{15} surface atoms on 1 cm^2 metal surface area, at complete coverage of all adsorption sites 1 m^2 working electrode surface area is required. If continuous electrode potential control during acquisition of the NMR spectrum is desired particular attention has to be paid to proper shielding and decoupling of the electrical wiring between potentiostat and NMR probe head. Results reported so far pertain in particular to ^{13}C -NMR spectroscopy of adsorbed CO and CN^- -ions on platinum [iv]. Besides information about surface diffusion and electronic adsorbate-surface interaction, data on the effect of the strong electric field at the electrochemical interface (typically 10^7 V cm^{-1}) have been reported. With both adsorbates the ^{13}C -resonance becomes more shielded at more positive electrode potentials as expected when assuming an adsorbate attachment via the carbon atom. These results were supported with data from ^{195}Pt -NMR spectroscopy [v]. Differences in the electrooxidation of methanol and CO on carbon-supported platinum have been associated with different linewidths of the ^{13}C -signal [vi].

The use of NMR spectroscopies with various species like, e.g., H, F, Na, Al, or Li in studies of solid electrolytes has been reviewed elsewhere [vii].

Refs.: [i] Holze R (2008) *Surface and interface analysis: an electrochemists toolbox*. Springer, Berlin; [ii] Wu J, Day JB, Franaszczuk K, Montez B, Oldfield E, Wieckowski A, Vuissoz PA, Ansermet JP (1997) *J Chem Soc Faraday Trans* 93:1017; [iii] Day JB, Wu J, Oldfield E, Wieckowski A (1998) *Instrumental design and prospects for NMR-electrochemistry*. In: Lorenz WJ, Plieth W (eds) *Electrochemical nanotechnology*. Wiley-VCH, Weinheim, p 291; [iv] Tong YY, Kim HS, Babu PK, Wieckowski A (2002) *J Am Chem Soc* 124:468; [v] Babu PK, Tong YY, Kim HS, Wieckowski A (2001) *J Electroanal Chem* 524–525:157; [vi] McGrath P, Fojas AM, Rush B, Reimer JA, Cairns EJ (2006) *Electrochemical Society Spring Meeting 209th, Denver, Colorado, USA, May 7–11, Ext. Abstr. #1097*; [vii] Wagner JB Jr (1991) *Techniques for the study of solid ionic conductors*. In: Varma R, Selman JR (eds) *Techniques for characterization of electrodes and electrochemical processes*. Wiley, New York, p 3

RH

Second harmonic generation spectroscopy

— The optical response of some media upon illumination with light of sufficiently high intensity can become nonlinear, i.e., in the reflected or transmitted light second, third or higher harmonics of the fundamental frequency of the illuminating light can be observed. This is par-

ticularly helpful in interfacial studies because the second harmonic generation (SHG) is governed by selection rules which localize the origin to regions (or more generally media) lacking inversion symmetry. The interface region between two centrosymmetric media provides this particular asymmetry quite naturally, thus the method is by itself surface-specific. The generated harmonic provides information about electronic and structural properties of the interface, but only to a limited extent of adsorbed species on the surface. Depth of penetration of the incoming probe and depth of information of the obtained signal are about 2 to 3 atomic layers of the solid. In case of single crystal surfaces and of systems where the surface nonlinear susceptibility is dominated by molecular contributions from the adsorbate, dependencies on the angle of rotation of the surface may be observed. Theoretical treatments have been provided [i, ii]. The theory of the generation of second harmonics via plasmon surface polaritons has been described [iii]. A theoretical treatment of the combined effects of wavelength of illuminating light and rotational anisotropy useful in investigations of single crystal/solution interfaces has been given [iv], a general overview is available [v].

Refs.: [i] Richmond GL, Robinson JM, Shannon VL (1988) *Progr Surf Sci* 28:1; [ii] Richmond GL (1991) *Optical second harmonic generation as an in situ probe of electrochemical interfaces*. In: Bard AJ (ed) *Electroanalytical chemistry*, vol. 17. Marcel Dekker, New York, p 87; [iii] Corn RM, Romagnoli M, Levenson MD, Philpott MR (1984) *J Chem Phys* 81:4127; [iv] Georgiadis R, Richmond GL (1991) *J Phys Chem* 95:2895; [v] Holze R (2008) *Surface and interface analysis: an electrochemists toolbox*. Springer, Berlin

RH

Simultaneous application of spectroscopy in voltammetry — Numerous spectroelectrochemical methods employ spectrometers fast enough to acquire complete spectra within seconds or fractions of a second. Acquisition of spectra during a slow \rightarrow electrode potential scan as employed in \rightarrow cyclic voltammetry or during single scan voltammetry can thus be related to a single electrode potential (within a range of a few millivolts or even more narrow). Thus interfacial phenomena as detected with the applied spectroelectrochemical technique can be related to the electrode potential directly even in case of unstable intermediates.

Ref.: [i] Holze R (2008) *Surface and interface analysis: an electrochemists toolbox*. Springer, Berlin; [ii] Neudeck A, Marken F, Compton RG (2005) *UV/Vis/NIR spectroelectrochemistry*. In: *Electroanalytical Methods*. Scholz F (ed), Springer, Berlin, pp 167

RH

Spectroellipsometry — Measurements employing \rightarrow ellipsometry are frequently carried out at a single, fixed wavelength (as provided by, e.g., the particular light source of the ellipsometer). Experiments done with continuously varied wavelengths are called \rightarrow spectroellipsometry.

Ref.: [i] Holze R (2008) *Surface and interface analysis: an electrochemists toolbox*. Springer, Berlin

RH

Spectromicroscopy — Most optical spectroscopies probe rather large areas or volumes because the beam of light (whether infrared, UV-Vis, or X-ray etc.) probing the electrochemical interface or the electrolyte solution volume in front of the electrode (the interphase) has a finite diameter ranging from several 10 micrometers to a few millimeters or even more. Thus, spatially or locally resolved information cannot be obtained. Employing confocal or near-field optics very small surface areas can be probed, resolutions down to a few micrometers are possible.

Ref.: [i] Holze R (2008) *Surface and interface analysis: an electrochemists toolbox*. Springer, Berlin

RH

Specular reflectance spectroscopy — Spectroscopic techniques using light in the UV-Vis and the infrared range impinging on the electrode surface and reflected away from the surface at the angle of incidence are called specular reflectance spectroscopies (see \rightarrow UV-Vis spectroscopy, \rightarrow infrared spectroscopy).

Ref.: [i] Holze R (2008) *Surface and interface analysis: an electrochemists toolbox*. Springer, Berlin

RH

Sum frequency spectroscopy — Sum frequency generation, SFG (because mostly vibrational modes at interfaces are investigated, the method has also been called vibrational sum frequency generation, VSFG) and the closely related difference frequency generation DFG are second-order nonlinear optical processes. Light of a fixed frequency ω_1 interacts at the studied interface with light of a frequency ω_2 thereby generating a coherent beam with the frequency $\omega_s = \omega_1 + \omega_2$ in SFG and $\omega = \omega_1 - \omega_2$ in DFG. This is basically the result of the nonlinear susceptibility of the interface and the nonlinear polarizability of adsorbed species. The interface region between two centrosymmetric media provides this particular asymmetry quite naturally, thus the method is by itself surface-specific. With one light frequency being tunable the resulting sum frequency can be tuned accordingly. According to theory the SFG intensity is enhanced when either ω_s , ω_1 , or ω_2 are in resonance with a vibrational transition in an adsorbate be-

ing present at the interface or an electronic transition in, e.g., the metal of the electrode. In addition, the vibrational mode of the adsorbate has to be both infrared- and Raman-active. Because of the large reduction in molecular symmetry upon adsorption on a surface this condition is met in most cases. With a light source of tunable frequency emitting in the infrared (e.g., a tunable infrared laser diode, a tunable infrared laser (CO laser, dye laser) or a free-electron laser) the vibrational properties of the interface (i.e., of adsorbates and their bonding to the metal surface) can be probed. Besides their conceptual similarity DFG differs from SFG in two details. The more stringent phase matching requirements for the two light beams poses narrower limits for the experimental design. A more effective filtering of the light emitted from the interface is necessary because of the competition between the desired DFG signal and the undesired fluorescence sometimes induced by the visible light beam. SFG at metal/solution and other interfaces has been reviewed extensively [i–vii].

Refs.: [i] Holze R (2008) *Surface and interface analysis: an electrochemists toolbox*. Springer, Berlin; [ii] Richmond GL (2002) *Chem Rev* 102:2693; [iii] Richmond GL (2001) *Annu Rev Phys Chem* 52:357; [iv] Eisenthal KB (1996) *Chem Rev* 96:1343; [v] Schultz ZD, Shaw SK, Gewirth AA (2005) *J Am Chem Soc* 127:15916; [vi] Guyot-Sionnest P, Tadjeddine A (1990) *Chem Phys Lett* 72:341; [vii] Richmond GL (2002) *Chem Rev* 102:2693

RH

Surface-enhanced Raman scattering spectroscopy — (→ *surface enhanced Raman scattering*) Molecular species at the electrochemical interface or within the interphase may scatter light inelastically provided that involved species are Raman-active. The low yield provided by the limited number of scattering species in particular of adsorbates makes detection difficult. Surface enhancement based on locally increased electric field at nanoscopic roughness features of the interface and on specific chemical adsorbate-surface interactions (chemical enhancement) causes an enhancement of the scattered light intensity by several orders of magnitude, making detection possible. For further details see → *surface enhanced Raman scattering*.

Refs.: [i] Holze R (2008) *Surface and interface analysis: an electrochemists toolbox*. Springer, Berlin; [ii] Aroca R (2006) *Surface-enhanced vibrational spectroscopy*. Wiley, Chichester

RH

Synchrotron techniques in spectroscopy — Synchrotrons can be used as sources of electromagnetic radiation in particular in the X-ray and the infrared range. Synchrotrons are circular electron beam accelerators. Electrons traveling on a circular orbit emit radi-

ation whose energy distribution depends on the energy of the travelling electrons. Adjusting the electron energy allows the generation of electromagnetic radiation with a broad range of frequencies extending from the far infrared into the range of hard X-rays; in a typical setup the energy can be continuously varied from 10 to 2700 eV. In addition, this radiation shows a defined time structure, it is completely polarized [i–viii]. It is used in numerous spectroscopies, in particular in → *X-ray (absorption) spectroscopy* (→ EXAFS, → NEXAFS, → XANES) and in → *sum frequency generation SFG* (see → *nonlinear spectroscopies*).

Refs.: [i] Holze R (2008) *Surface and interface analysis: an electrochemists toolbox*. Springer, Berlin; [ii] Koch EE (ed) (1983) *Handbook of synchrotron radiation*, vol. 1. North Holland, Amsterdam; [iii] Koch EE (ed) (1983) *Handbook of synchrotron radiation*, vol. 2. North Holland, Amsterdam; [iv] Marr GV (ed) (1987) *Handbook of synchrotron radiation*, vol. 3. North Holland, Amsterdam; [v] Kunz C (1979) *Synchrotron radiation – techniques and applications*. Springer, Berlin; [vi] Winick H, Doniach S (ed) (1980) *Synchrotron radiation research*. Plenum Press, New York; [vii] Margaritondo G (1988) *Introduction to synchrotron radiation*. Oxford University Press, Oxford; [viii] Agarwal BK (1991) *X-ray spectroscopy*. Springer, Berlin

RH

UV-Vis spectroscopy — Electronic absorption in the UV-Vis range by species generated during electrochemical reactions or being present at the electrochemical interface between the electronically conducting electrode and an ionically conducting phase (electrolyte solution, molten electrolyte, ionic liquid, solid electrolyte) can be studied with in situ UV-Vis spectroscopy in various modes [i–iii]:

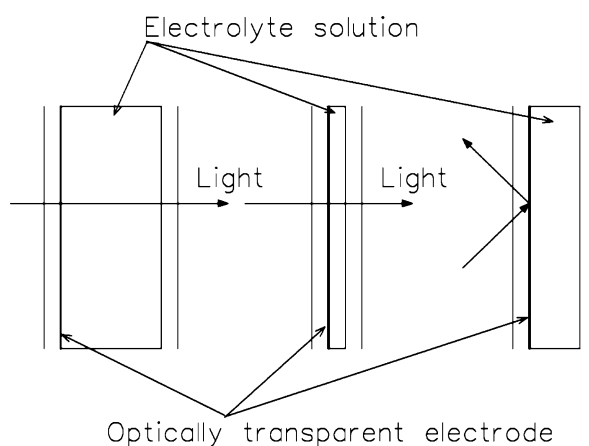

Spectroscopy (spectrometry) — UV-Vis spectroscopy — Figure 1

→ *optically transparent electrodes (OTE)* can be used for studying species (including molecular adsorbates as

well as polymer films or other modifying layers) attached to the electrode surface (middle) or being present in the phase adjacent to the electrode (left). External reflection may be applied with opaque \rightarrow electrode materials (e.g., solid metal or carbon electrodes) (right). A typical experimental setup operated in the transmission mode is shown below.

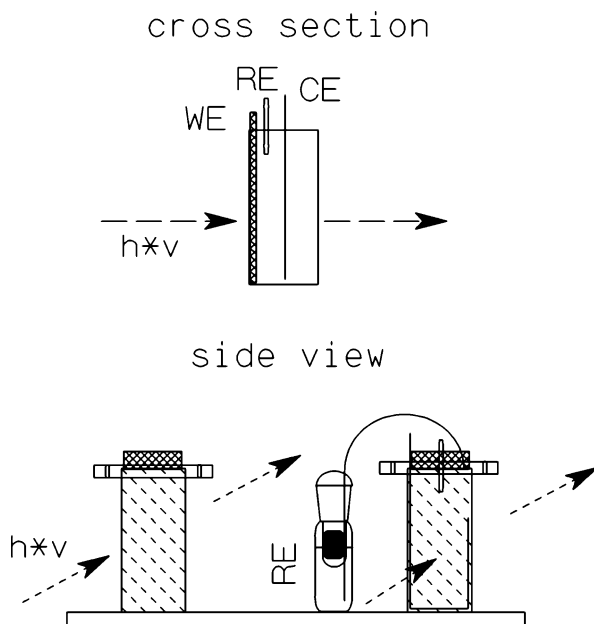

Spectroscopy (spectrometry) — UV-Vis spectroscopy — Figure 2

Electronically conducting layers of sputtered metals (gold, platinum) or indium-doped tin oxide (ITO) are employed as optically transparent electrodes. UV-Vis spectra of the investigated species are obtained in double-beam instruments by inserting a cell (frequently a standard cuvet as used for general UV-Vis spectroscopy only slightly modified to accommodate the glass sheet used as OTE, a metal wire as \rightarrow counter electrode and the connection to the \rightarrow reference electrode) with supporting electrolyte solution only and (if necessary) an unmodified OTE in the reference beam. The resulting spectrum obtained with the complete electrochemical cell in the sample channel shows only absorptions caused by species and phenomena depending on the applied \rightarrow electrode potential (see Figure 3).

Opaque or bulk electrode materials can be studied also in the transmission mode provided they can be manufactured into minigrids or fine mesh. The light passing the openings will interact with electrolyte solution inside the openings as well as the film on the grid

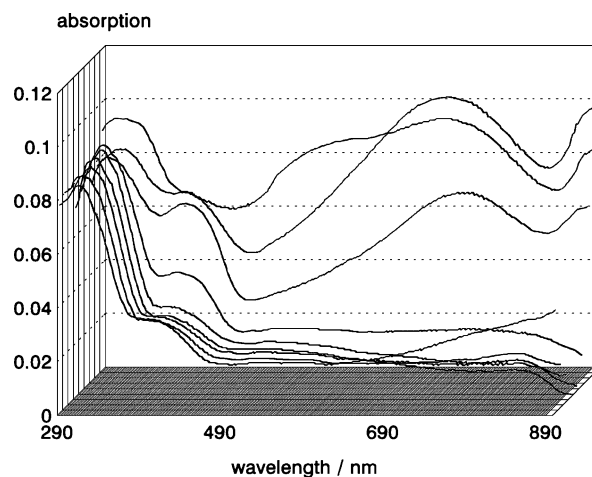

Spectroscopy (spectrometry) — UV-Vis spectroscopy — Figure 3. UV-Vis spectra of a \rightarrow conducting polymer layer of poly(2-propylaniline) deposited on a gold-sputtered glass slide OTE, $E_{SCE} = -300$ to $+600$ mV (first to last trace)

(if there is a film to be studied). In the external reflection mode light from the source of the \rightarrow spectrometers is guided with the necessary optical accessory towards the interface through a window in the electrochemical cell, the reflected beam is guided towards the monochromator/detector. When passing the \rightarrow electrolyte solution absorption proceeds, the same applies to a film on the electrode surface. Beyond the single reflection (also called specular reflection or \rightarrow specular reflectance spectroscopy) multiple reflections are possible in the attenuated total reflectance ATR mode. A typical setup is shown below.

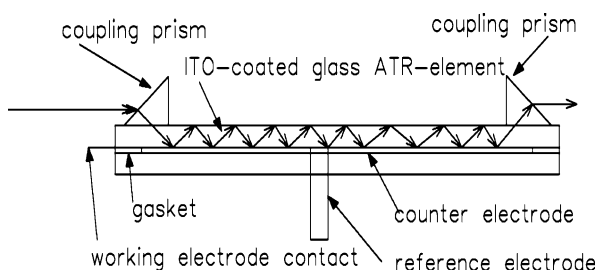

Spectroscopy (spectrometry) — UV-Vis spectroscopy — Figure 4

The ATR element is coated with the electrode material to be investigated; besides ITO other materials which can be sputtered or evaporated on the ATR crystal are applicable.

Properties of the electrode material (in particular metals) itself (e.g., electronic band structure or features related to surface crystallography) can be studied in the

external reflection mode in a method called electroreflectance spectroscopy [ii]. Differential spectra obtained by rapid electrode potential modulation employing light at alternatively parallel and perpendicular polarization orientation yield the desired information.

Refs.: [i] Holze R (2008) *Surface and interface analysis: an electrochemists toolbox*. Springer, Berlin; [ii] Kolb DM (1988) *UV-visible reflectance spectroscopy*. In: Gale RJ (ed) *Spectroelectrochemistry*. Plenum Press, New York, p 87

RH

X-ray spectroscopy — X-ray spectroscopy of matter can be performed as emission or absorption spectroscopy. In electrochemical investigations only the latter is of interest. Interaction of X-rays with matter results in removal of an electron from an inner, core-near shell. There, electronic states next to the state from which the electron is removed are filled so that the electron has to be transferred to empty outer states, actually it is removed from the atom. Upon passage of X-rays through a sample of thickness x the intensity after passage I as compared to the initial intensity I_0 is given by

$$I = I_0 e^{-\mu_1 x}$$

with linear attenuation coefficient μ_1 . μ_1 divided by sample density ρ is the mass attenuation coefficient μ_m , a property typical of an atom not depending on the particular phase state of the material. The atomic attenuation coefficient μ_a is related according to

$$\mu_a = \mu_m A / N_A$$

with atomic mass A and Avogadro number N_A . The spectrum displays μ_1/ρ ($= \mu_m$) as a function of wavelength. Typical absorption edges corresponding to ejection of electrons from their respective states (shells) are observed. The actual position of an absorption edge depends on the chemical environment of the absorbing atom. Closer inspection of the spectrum around the edge reveals a fine structure amounting to about 15% of the absorption jump. It is caused by interference between electrons emitted from the atom under investigation with electrons of the surrounding atoms. This analysis of the edge structure itself and the part slightly above the edge is called \rightarrow EXAFS (extended X-ray absorption fine structure (spectroscopy) see also \rightarrow SEXAFS). Analysis of the edge and the part slightly below is called \rightarrow NEXAFS (near edge X-ray absorption fine structure) or \rightarrow XANES (X-ray absorption near-edge structure). The methods are employed to study interfacial structure features: adsorbate–surface interactions (e.g., distances

r_{AS} between adsorbate and surface, distances inside adsorbates r_{AB} bonding angles α , number of interacting species).

Refs.: [i] Holze R (2008) *Surface and interface analysis: an electrochemists toolbox*. Springer, Berlin; [ii] Agarwal BK (1991) *X-ray spectroscopy*. Springer, Berlin; [iii] Tsuji K, Injuk J, Van Grieken R (eds) (2004) *X-ray spectrometry: recent technological advances*. Wiley, Chichester

RH

Specular reflectance spectroscopy \rightarrow spectroscopy

SPM \rightarrow scanning probe microscopy

SPS \rightarrow scanning probe spectroscopy

Square wave polarography \rightarrow polarography

Square-wave voltammogram \rightarrow reversible square-wave voltammogram, \rightarrow square-wave voltammetry

Square-wave voltammetry — There are two fundamental protocols which are commonly referred to as **square-wave voltammetry**: 1. a square wave potential waveform is superimposed upon an underlying voltage ramp and 2. a square wave potential waveform is superimposed upon an underlying voltage staircase. A plethora of named protocols are further distinguished by the mode of current sampling which can be dense as is the case with Fourier Transform Square-Wave Voltammetry (see \rightarrow Fourier transform voltammetry) [i] or sparse as is the case with \rightarrow Osteryoung and \rightarrow Barker protocols with the objective (sometimes but not always met) of rejecting the capacitive and background components of the current [ii–vi]. \rightarrow square-wave polarography commonly denotes the special case of square-wave voltammetry applied to a \rightarrow dropping mercury electrode. See also \rightarrow Barker square-wave voltammetry and \rightarrow Osteryoung square-wave voltammetry.

Refs.: [i] Bond AM, Duffy NW, Guo S, Zhang J, Elton D (2005) *Anal Chem* 77:186A; [ii] Thomas FG, Henze G (2001) *Introduction to voltammetric analysis. Theory and practice*. CSIRO Publishing, Collingwood VIC, pp 39–43; [iii] Osteryoung J, O'Dea JJ (1986) *Square-wave voltammetry*. In: Bard AJ (ed) *Electroanalytical chemistry*, vol. 14. Marcel Dekker, p 209; [iv] Bond AM (1980) *Modern polarographic methods in analytical chemistry*. Marcel Dekker, pp 391–399; [v] Lovrić M (2002) *Square-wave voltammetry*. In: Scholz F (ed) *Electroanalytical methods*. Springer, Berlin, pp 111–136; [vi] Mírčeski V, Komorsky-Lovrić Š, Lovrić M (2007) *Square-wave voltammetry*. In: Scholz F (ed) *Monographs in Electrochemistry*. Springer, Berlin

AMB

SRAM → DRAM

Stability constant — is the → *equilibrium constant* of formation of a → *complex*. The reciprocal quantity is called *instability constant*. Extensive compilations of various kinds of stability constants are available [i–iv]. Stability constants are reported for a given ionic strength (or extrapolated to zero ionic strength), and pH. In many cases, stability constants can be determined with the help of electrochemical techniques, e.g., → *chronopotentiometry*, → *potentiometry*, → *polarography*, and → *voltammetry*, provided that the systems exhibit → *electrochemical reversibility*, and some other prerequisites are fulfilled [v]. See also → *conditional equilibrium constants*.

Refs.: [i] Sillén LG, Martell AE (1964) *Stability constants of metal-ion complexes*, 2nd edn. The Chemical Society, London; [ii] Sillén LG, Martell AE (1971) *Stability constants of metal-ion complexes, supplement no. 1*. The Chemical Society, London; [iii] Kotrlý S, Šucha L (1985) *Handbook of chemical equilibria in analytical chemistry*. Ellis Horwood, Chichester; [iv] The IUPAC stability constants database: http://www.iupac.org/dhtml_home.html; [v] Galus Z (1994) *Fundamentals of electrochemical analysis*, 2nd edn. Ellis Horwood, New York, Polish Scientific Publ PWN, Warsaw

Stabilized zirconia — a family of → *solid electrolytes* with oxygen → *ion conductivity*, based on the cubic fluorite-type ZrO_2 phase doped with lower-valence cations. The cubic phase of zirconium dioxide (zirconia) is the high-temperature polymorph, which transforms on cooling into the tetragonal and, then, monoclinic modifications with low ionic conduction. Moderate → *doping* with Y^{3+} , Sc^{3+} , Yb^{3+} and other rare-earth cations having a small ionic radius makes it possible to stabilize the cubic phase down to relatively low temperatures. The maximum ionic conductivity in ZrO_2 -based systems is observed when the concentration of acceptor-type dopant(s) is close to the minimum necessary to completely stabilize the cubic lattice (see figure). The highest conductivity level in $Zr_{1-x}Y_xO_{2-x/2}$ and $Zr_{1-x}Sc_xO_{2-x/2}$ ceramics is observed at $x = 0.08–0.11$ and $0.09–0.11$, respectively. Further additions decrease the ionic conduction due to progressive association of the oxygen vacancies and dopant cations (see also → *defects in solids*). The $Zr_{1-x}Y_xO_{2-x/2}$ ceramics, called yttria-stabilized zirconia (YSZ), is among the most widely used solid electrolytes. With respect to other solid electrolytes, stabilized zirconia ceramics exhibit a minimum electronic contribution to total conductivity in the oxygen → *chemical potential* range most important for practical applica-

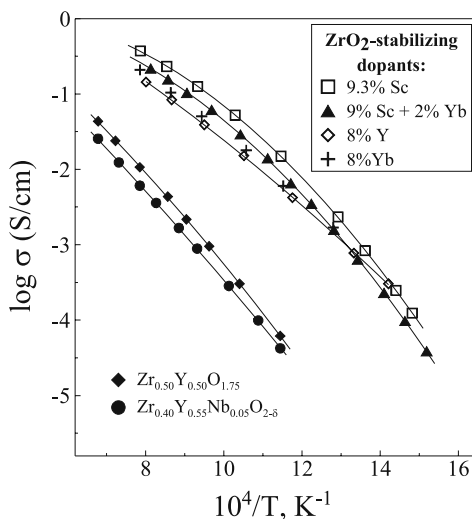

Stabilized zirconia — Figure. Oxygen ionic conductivity of stabilized zirconia ceramics as a function of reciprocal temperature at different dopant concentrations. See [ii] for details

tions. This range corresponds to the oxygen partial pressures from 10–20 MPa atm down to 10^{-23} – 10^{-15} Pa. The → *electrolytic domain* of stabilized zirconia is larger compared to other high-conductivity solid electrolytes, such as doped → *cerium dioxide* and → *BIMEVOX*.

Refs.: [i] Rickert H (1982) *Electrochemistry of solids. An introduction*. Springer, Berlin; [ii] Kharton VV, Marques FMB, Atkinson A (2004) *Solid State Ionics* 174:135

VK

Stackelberg, Mark Freiherr von



(Reproduced from [iii])

(Dec. 16, 1896, Dorpat, Russian Empire, now Tartu, Estonia – Apr. 4, 1971, Bonn, Germany) Mark von Stackelberg, the son of a German-Baltic noble family, grew up on their estate in Sutlem (now Sutlema), attended school in Reval (now Tallinn) and started to study science in Dorpat, what was very difficult in the

years 1915–17. His German parents has been deported to Siberia because Russia forced a Russification of that area. From 1918 to 1920 v. Stackelberg served in the Baltic home defense. Expropriated by the newly formed state Estonia, the family moved to Bavaria (Germany), and in 1920 Mark von Stackelberg started to study physical chemistry in Munich, where he worked with K. Fajans, and later in Erlangen with → *Lange*. In 1925 he moved to Bonn and became assistant of Andreas von Antropoff, Professor of Physical Chemistry. In 1930 he became ‘Privatdozent’, in 1936 Adjunct Professor and in 1961 Assistant Professor. In his habilitation v. Stackelberg worked on the crystallography of carbides, and later he continued that direction with studies of nitrides, phosphides, borides, and even phase-theoretical studies of gas hydrates. Together with H.J. Antweiler he focused his attention to streaming phenomena at mercury electrodes (→ *polarographic maxima*), and later he studied polarographic systems more and more deeply (→ *polarography*). He published the book “Polarographische Arbeitsmethoden” [i], and he is the senior co-author of “Die neuartigen polarographischen Methoden” [ii] in which he presented an overview on modern techniques, as → *differential pulse polarography*, → *AC polarography*, → *square-wave polarography*, etc. A detailed assessment of his achievements has been published by → *J. Heyrovský* [iii] and his numerous contributions to polarography are well documented in [iv].

Refs.: [i] Stackelberg M v (1950) *Polarographische Arbeitsmethoden*. Walter de Gruyter, Berlin; [ii] Schmidt H, Stackelberg M v (1962) *Die neuartigen polarographischen Methoden*. Verlag Chemie, Weinheim; [iii] Heyrovský J (1961) *Z Elektrochem* 65:817; [iv] Heyrovský J, Kuta J (1966) *Principles of polarography*. Academic Press, New York

Stagnant hydrodynamic layer → *hydrodynamic boundary layer*

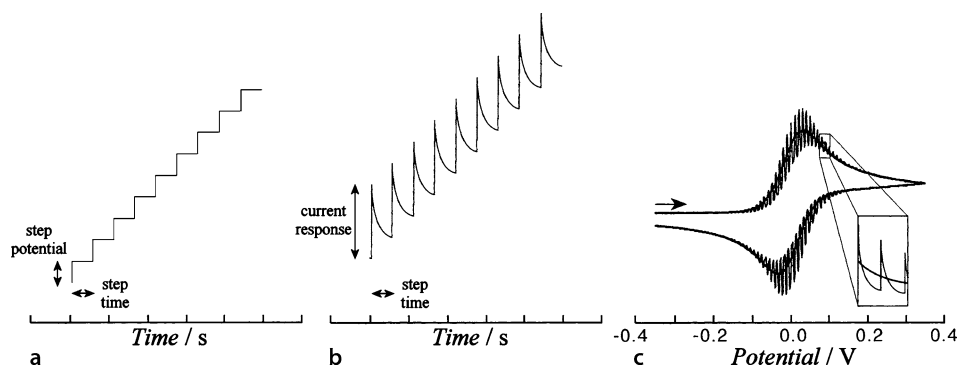

Staircase voltammetry — Figure

Staircase voltammetry — Staircase voltammetry has been developed in order to improve the quality of voltammetric data by suppressing background charging currents [i, ii]. Historically, an early version of staircase voltammetry was *tast polarography* (→ *polarography*) which is a technique developed for the → *dropping mercury electrode*. During the formation of each mercury droplet a constant potential was applied resulting in a stepwise sweep of the applied potential (a). The resulting current response (b) contains capacitive background current early in the step (exponential decay) and faradaic current (→ *Cottrell equation*) in the later part of the step ($t^{-1/2}$ decay). By not sampling the early data points during the step, the capacitive background current in voltammograms can be suppressed. In staircase voltammetry at solid electrodes the step time and the potential step parameter can be freely chosen and for small enough step time and potentials data consistent with conventional linear sweep voltammetry is obtained.

Today, computer-controlled → *potentiostat* systems operate by applying small potential steps rather than a smooth potential ramp for example during → *differential staircase voltammetry* or during → *cyclic voltammetry* or → *cyclic staircase voltammetry* measurements and therefore staircase voltammetry has become ubiquitous. The resulting cyclic staircase voltammogram (c) is identical to analog cyclic voltammograms as long as the potential step and time step are small [iii].

The signal from staircase voltammograms can be further analyzed by → *Fourier transformation* and analysis of the frequency domain data [iv].

Refs.: [i] Bard AJ, Faulkner LR (2001) *Electrochemical methods*, 2nd edn. Wiley, New York; [ii] Bond AM (1980) *Modern polarographic methods in analytical chemistry*. Marcel Dekker, New York; [iii] Bilewicz R, Wikiel K, Osteryoung R, Osteryoung J (1989) *Anal Chem* 61:965; [iv] Gavaghan DJ, Elton D, Bond AM (2001) *J Electroanal Chem* 513:73

FS

FM

Standard cell — An electrochemical cell composed of two \rightarrow *half-cells* containing electrodes built according to standard (normal) conditions. Frequently the term is also used for electrochemical cells showing a well-defined, reproducible, and stable cell voltage suitable for calibration purposes (\rightarrow *Weston cell*, \rightarrow *Clark cell*).

RH

Standard deviation — (of a population of data) (σ) A measure of the \rightarrow *precision* of a population of data. It is the positive square root of the sum of the squares of the deviations between the observations and the \rightarrow *population mean* (μ), divided by the total number of replicate

data [i]. It can be calculated as: $\sigma = \sqrt{\frac{\sum_{i=1}^n (\mu - x_i)^2}{n}}$.

Ref.: [i] Skoog D, West D, Holler F, Crouch SR (2003) *Fundamentals of analytical chemistry*, 8th edn. Brooks/Cole, Belmont

FG

Standard deviation of a fit \rightarrow *residual standard deviation*

Standard electrode potential \rightarrow *potential*

Standard electrode potential series \rightarrow *potential*, and subentries \rightarrow *standard potential*, and \rightarrow *tabulated standard potentials*

Standard hydrogen electrode — The standard \rightarrow *hydrogen electrode* (SHE) is the primary standard in electrochemistry [i–v]. It is also called normal hydrogen electrode (NHE), however, this usage is no longer recommended.

The \rightarrow *standard potential* of an \rightarrow *electrode reaction* (standard electrode potential) is defined as the value of the standard potential of a \rightarrow *cell reaction* (E^\ominus) when that involves the oxidation of molecular hydrogen to solvated (hydrated) protons (hydrogen ions):

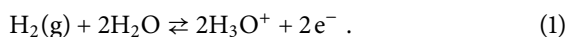

It is even better to write this reaction as

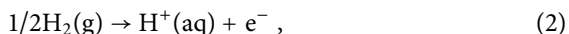

where the notation $\text{H}^+(\text{aq})$ represents the hydrated proton in aqueous solution without specifying the \rightarrow *hydration* sphere.

The standard state is the hypothetical ideal solution of molality 1 mol kg^{-1} (or the relative \rightarrow *activity* of H_3O^+ , $a_{\text{H}_3\text{O}^+} = 1$) at standard pressure (p^\ominus). The standard pressure is $1 \text{ bar} = 10^5 \text{ Pa}$. Earlier $p^\ominus = 1 \text{ atm} = 1.01325 \text{ bar}$ was used, however it causes a difference in the potential of SHE of $+0.169 \text{ mV}$, that is, this value has to be subtracted from the E^\ominus values given previously in different tables. Since the large majority of the E^\ominus values have

an uncertainty of at least 1 mV , this correction can be neglected. By definition, the potential of this electrode is zero. The standard state for the element hydrogen is the diatomic molecule in gaseous state at 298.15 K containing an equilibrium mixture of the ortho and para isomers (normal hydrogen). By convention, the term of SHE or NHE does not refer to isotopically pure hydrogen, but it is taken to mean hydrogen that contains deuterium at the levels of natural abundance (0.015%).

Thermodynamically it means that not only the standard free energy (\rightarrow *Gibbs energy*) of formation of hydrogen ($\mu_{\text{H}_2}^\ominus$) is zero – which is a rule in thermodynamics – but also that of the solvated hydrogen ion $\mu_{\text{H}^+}^\ominus = 0$.

Although the standard potential should not depend on the material of the metal, the SHE exclusively contains a platinum wire or a platinum sheet covered with platinum black (\rightarrow *platinized platinum*). Owing to the spontaneous dissociation (dissociative \rightarrow *chemisorption*) of H_2 at Pt:



and the not-too-high Pt–H bond energy, the \rightarrow *exchange current* is high and the electrode process is \rightarrow *electrochemically reversible*.

In some nonaqueous solvents, it is necessary to use a standard reaction other than the oxidation of molecular hydrogen. At present, there is no general choice of a standard reaction (reference electrode), however, much effort has been taken to find reliable reference reactions [iii–v].

Refs.: [i] Bard AJ, Parsons R, Jordan J (eds) (1985) *Standard potentials in aqueous solution*. Marcel Dekker, New York; [ii] Mills I, Cvitas T, Homann K, Kallay N, Kuchitsu K (eds) (1993) *IUPAC quantities, units and symbols in physical chemistry*. Blackwell Scientific Publications, Oxford, pp 58–61; [iii] Parsons R (1974) *Pure Appl Chem* 37:503; [iv] Inzelt G (2006) *Standard potentials* (chap. 1). *Platinum* (chap. 17.3). In: Bard AJ, Stratmann M, Scholz F, Pickett C (eds) *Encyclopedia of electrochemistry*, vol. 7. Wiley-VCH, Weinheim; [v] Kahlert H (2002) *Reference electrodes*. In: Scholz F (ed) *Electroanalytical methods*. Springer, Berlin, pp 263–264

GI

Standard potential \rightarrow *potential*

Standard rate coefficient \rightarrow *Butler–Volmer equation*

Standard rate constant \rightarrow *reaction rate*

Standard solution — A sufficient stable solution of a reagent of an exactly known concentration that is normally used for the \rightarrow *titration* of a suitable \rightarrow *analyte*. The

reagent must react rapidly, completely, and stoichiometrically with the analyte [i].

Ref.: [i] Harris D (2002) *Quantitative chemical analysis*. WH Freeman, New York

FG

Standard uncertainty — The → *uncertainty* of the result of a measurement expressed as a → *standard deviation* [i].

Ref.: [i] Skoog D, West D, Holler F, Crouch SR (2003) *Fundamentals of analytical chemistry*, 8th edn. Brooks/Cole, Belmont

FG

Standardization — A process by which the concentration of a volumetric solution is ascertained [i].

Ref.: [i] Harris D (2002) *Quantitative chemical analysis*. WH Freeman, New York

FG

Standby battery → *Batteries* designed to supply electricity, in a very rapid manner, upon power failure. These can be either rechargeable or primary batteries. They are manufactured at a wide spectrum of sizes, from small → *button cells*, to several 10's kAh batteries, depending on the very application. Many different chemical systems are used for standby batteries, each with its particular characteristics. The most important properties one has to take into consideration in selecting the appropriate standby battery are: → *shelf life*, shelf and service temperatures, power capabilities, cost, and reliability. When selecting a secondary standby battery one has to take into account that an appropriate charging system has to be acquired as well. One important characteristic that some standby batteries exhibit is voltage delay. It appears as a period of time in which the battery, after putting into service, will take until it will deliver the rated voltage and power. If the application cannot tolerate such conditions a different standby battery has to be selected. Of the rechargeable standby batteries the most important is the → *lead-acid*, which is the work horse for communication and large power standby UPS systems, although → *nickel-cadmium* has its share as well. Rechargeable standby batteries are frequently charged continuously on float charging or trickle charging to compensate for self discharge or small power drain. The most important primary standby batteries are those that use lithium anodes, as they exhibit excellent shelf life, highest energy density, reliability, and scalability. They are very frequently used as small drain memory backup (i.e., Li-MnO₂), and as high power backup, 10 kAh Li-SOCl₂ installations for missile silos.

Refs.: [i] Crompton TR (2000) *Battery reference book*, 3rd edn. Newnes, Oxford, pp 9/3, 8/14–8/15, 19/7, 19/10, 32/3–32/7, 37/3, 38/3–38/5, 50/3–50/33, 51/20–51/56; [ii] Linden D (1994) *Lithium cells*. In: Linden D (ed) *Handbook of batteries*, 2nd edn. McGraw-Hill, New York, chap. 14, pp 14.1–14.91

YG

Starved electrolyte battery — A → *battery* with minimum amount of → *electrolyte*. The electrolyte in starved electrolyte cells or batteries exists in the porous structure of the → *electrodes* and absorbed in the separator, so it contains little or no free fluid electrolytic solution. This type of batteries is used in certain constructions of sealed → *lead-acid* and → *nickel-cadmium batteries* that rely on gas diffusion and recombination on the electrodes during charging or overcharging in order to maintain maintenance-free conditions, and to suppress pressure buildup. Starved electrolyte batteries benefit from larger → *energy density* due to the reduced amount of electrolyte. This design may suffer from poor heat dissipation compared with → *flooded batteries*, thus for high power applications this point has to be taken into account.

Refs.: [i] Linden D (1994) *Handbook of batteries*, 2nd edn. McGraw-Hill, New York, Appendix A, p A.10.; [ii] Nagy Z (ed) (2005) *Online electrochemistry dictionary*. <http://electrochem.cwru.edu/ed/dict.htm>; [iii] Crompton TR (2000) *Battery reference book*, 3rd edn. Newnes, Oxford, p 18/7, 19/13; [iv] Gates Energy Products (1998) *Rechargeable batteries applications handbook*. Newnes, p 158; [v] Dhameja S (2001) *Electric vehicle battery systems*. Newnes, p 172–173

YG

State of charge — The amount of → *charge* stored in a → *battery*, at a certain point of charging or discharging (or idle), expressed as the percentage of the rated → *capacity*. Sometimes indicated as SoC. In some applications, especially in critical medical and military applications, the state of charge is extremely important information. The state of charge gives an indication of the electrical energy stored in the battery, available for discharge. The state of charge can be monitored in a variety of ways, each appropriate for a specific type of cell. The most common one is voltage measurement, although impedance and power measurements are also used. Many high-end → *alkaline batteries* include state of charge indicators as a part of the package or embedded in the battery label, based on liquid crystals that change color as a result of joule heating through a resistor, which indicates the state of charge by power measurement.

Refs.: [i] Gates Energy Products (1998) *Rechargeable batteries applications handbook*. Newnes, pp 124, 168, 181, 202–203; [ii] Bergveld HJ,

Kruijt WS, Notten PHL (2002) *Battery management systems: design by modelling*. Kluwer, Amsterdam, chap. 6, pp 193–239; [iii] Crompton TR (2000) *Battery reference book*, 3rd edn. Newnes, Oxford, pp 1/10, 1/26, 2/18, 4/5–4/5, 4/16, 9/8, 43/6 and chapters 44–49; [iv] Lerner S, Lennon H, Seiger HN (1970) *Development of an alkaline battery state of charge indicator*. In: Collins DH (ed) *Power Sources 3*. Oriel Press, Newcastle, pp 135–137; [v] Pop V, Bergveld HJ, Notten PHL, Regtien PPL (2005) *Meas Sci Technol* 16:R93

YG

Static mercury drop electrode (SMDE) — SMDE, or controlled growth mercury drop electrode, is an advanced automatic modification of the → *dropping mercury electrode*, in which flow of mercury from a wide bore capillary is abruptly stopped, and current is then measured shortly before the drop is dislodged from the capillary [i]. In that way the polarographic (→ *polarography*) curve with SMDE is recorded still with periodically renewed mercury electrode, but of time-constant, relatively large surface. This principle was suggested already in 1962 [i] (see → *Gokhshtein*), however, the commercial version of SMDE was introduced only in 1979 [ii]. The instantaneous polarographic diffusion-controlled current with SMDE then follows → *Cottrell equation*. The → *charging current*, which limits polarographic sensitivity, is suppressed with SMDE, and the detection limit in DC polarography is thus lowered by more than one order of magnitude. The sensitivity of the polarographic DC method with SMDE of $0.2\text{ s} < t_d < 2\text{ s}$ (t_d is the droptime) becomes comparable with that of the pulse methods [iii]. The instrumental arrangements for SMDE allow automatic formation of an HMDE (→ *Kemula electrode*) and are included in commercially produced apparatuses.

Refs.: [i] Gokhshtein AY, Gokhshtein YaP (1962) *Zh Fiz Khim* 36:651; [ii] Peterson WM (1979) *Am Lab* 11:69; [iii] Bond AM, Jones RD (1980) *Anal Chim Acta* 121:1

MHey

Static random access memory → *DRAM*

Stationary battery (cell) — Rechargeable → *batteries* designed to be located at a fixed place. Stationary batteries are used mainly for uninterruptible power supplies (UPS) and standby applications. These cells are usually designed for high reliability and very long → *cycle life* under shallow depth of discharge (DOD) conditions. The common chemical systems utilized for the production of stationary batteries are the → *lead–acid* and → *nickel–cadmium batteries*. Less common, and more futuristic is the → *sodium–sulfur battery* designed for KW and

MW installations. Recently there are also major efforts and some initial success in implementation of rechargeable lithium–ion technology for stationary applications. From the view point of global energy utilization and consumption, the ultimate goal for stationary batteries is power-line load leveling.

Refs.: [i] Crompton TR (2000) *Battery reference book*, 3rd edn. Newnes, Oxford, pp 32/3–32/7, 51/43, 62/3–62/4; [ii] Wagner R (2004) *Valve regulated lead–acid batteries for telecommunications and UPS applications*. In: Rand DAJ, Moseley PT, Garche J, Parker CD (eds) *Valve-regulated lead–acid batteries*. Elsevier, Amsterdam; [iii] Broussely M (2003) *Lithium–ion for EV, HEV and other industrial applications*. In: Nazri GA, Pistoia G (eds) *Lithium batteries: science and technology*. Kluwer, Amsterdam, pp 671–675

YG

Steady state — In electrochemistry, a steady state occurs when a variable of interest (e.g., a → *concentration*, a flux, a → *current*, or a → *potential*) does not change with time. A steady state is attained after a passage of time and theoretically requires an infinite length of time because steady states are approached gradually rather than being obtained at a specific instant. Thus “reaching a steady state” can mean coming to within some specified percentage of the steady state. However, steady states can be reached quickly: (1) in situations where two electrodes or an electrode and an insulating surface are located within micro- and nanometers of each other (e.g., in → *thin-layer cells*) and electrochemical reactions occur at one or both surfaces; (2) under conditions of high diffusive → *mass transport* induced by the size and shape of an electrode (e.g., → *ultramicroelectrodes*, UMEs); (3) in → *scanning electrochemical microscopy (SECM)* where a UME is within micro- or nanometers of another surface of larger, comparable, or smaller size; (4) under conditions where mass transport occurs by induced convection (e.g., → *rotating disk electrodes (RDE)* or → *rotating ring-disk electrodes (RRDE)*).

A steady state is independent of the details of the experiment used in attaining it. Thus, under conditions where a steady state is attained, e.g., under convective conditions in an → *electrochemical cell*, the application of a constant current leads to a constant potential and similarly the application of a constant potential leads to the same constant current. Voltammetric steady states are most commonly reached using linear potential sweeps (or ramps) in a single or cyclic direction at a UME or RDE. A sigmoidally shaped current (*I*)–potential (*E*) voltammogram (i.e., a steady-state voltammogram) is recorded in the method known as steady-state voltammetry as shown in the Figure. Characteristics of the

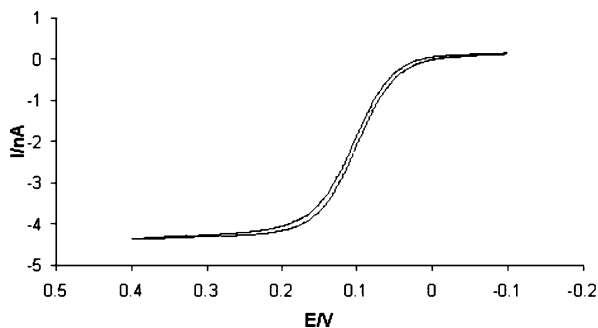

Steady state — Figure. Steady-state voltammogram at a 25 micrometer diameter Pt disk UME in a solution of 1 mM ferrocenemethanol in 0.1 M KCl electrolyte. The potentials are given with respect to Ag/AgCl. The potential was swept linearly at 10 mV/s from -0.1 V to 0.4 V and then back to -0.1 V

steady-state voltammogram include a steady-state limiting current, $I_L = -4.3$ nA (as shown in the Figure), and a forward and reverse steady-state current which are superimposed on each other. In the Figure, only the reduced species \rightarrow ferrocene methanol is present in the bulk solution. At potentials ranging from 0.2 to 0.4 V, the concentration of ferrocene methanol is driven to zero at the UME surface and this represents the steepest concentration gradient (e.g., complete concentration polarization) over the potential range and is reflected in the I_L value which is recorded. If both species of a \rightarrow redox couple are present in solution, then both anodic and cathodic limiting currents will be recorded, with an \rightarrow equilibrium potential at $I = 0$.

The shape of the steady-state voltammogram shown in Fig. 1 is typical of steady-state systems. The limiting current can be written generally as

$$I_L = nFAmC^* \quad (1)$$

where n refers to the number of \rightarrow electrons transferred, F is the \rightarrow Faraday constant, A is the electrode area, C^* is the bulk \rightarrow concentration, and m is referred to as a mass-transfer coefficient. The mass-transfer coefficient m can be written in several ways as follows:

$$m = 2D/L \quad \text{thin-layer steady-state cell,} \quad (2)$$

where D is the \rightarrow diffusion coefficient and L is the distance between the surfaces in the thin-layer cell;

$$m = D/r_0 \quad \text{hemispherical UME,} \quad (3)$$

where r_0 is the radius of the hemisphere;

$$m = 4D/\pi r_0 \quad \text{inlaid disk UME,} \quad (4)$$

and

$$m = 0.620D^{2/3}\omega^{1/2}(d/\eta)^{1/6} \quad \text{rotating disk electrode,} \quad (5)$$

where η and d are the viscosity and density of the solution, and ω is the rotation speed of the electrode.

Refs.: [i] Bard AJ, Faulkner LR (2001) *Electrochemical methods*, 2nd edn. Wiley, New York, chaps. 5, 6, 9, 11, 12; [ii] Bard AJ, Mirkin MV (eds) (2001) *Scanning electrochemical microscopy*. Marcel Dekker, New York; [iii] Oldham KB, Myland JC (1994) *Fundamentals of electrochemistry*. Academic Press, New York, chap. 8; [iv] Zoski CG (1996) *Steady-state voltammetry at microelectrodes*. In: Vanysek P (ed) *Modern techniques in electroanalysis*. Wiley, New York

CGZ

Stern double layer \rightarrow double layer

Stia counter — Mercury \rightarrow coulomb meter invented by Friedrich Otto Schott (1851–1935). In a closed glass tube a mercury drop contacted by a metal wire sealed into the end of the tube is used as an \rightarrow anode, a piece of graphite or more recently another wire sealed into the other end of the tube serves as \rightarrow cathode. Upon flow of a direct (DC) current mercury is dissolved into the aqueous electrolyte solution containing KCl and HgI and deposited at the cathode. A porous diaphragm prevents metallic drops of mercury to reach the anode. According to \rightarrow Faraday's law the amount of deposited mercury is directly proportional to the amount of charge passed through the cell and thus to the product of current and time. In current versions Stia counters of the size of small electric fuses are used to record the time of operation of electric instruments.

Ref.: [i] Fischer Lexikon Technik und exakte Naturwissenschaften (1972). Fischer, Frankfurt

RH

STM, in-situ electrochemistry — The scanning tunneling microscope (STM) is widely used in both industrial and fundamental research to obtain atomic-scale images of metal and other electrically conducting surfaces. It provides a three-dimensional profile of the surface, which is very useful for characterizing surface roughness, observing surface defects, and determining the size and conformation of molecules and aggregates on the surface. This technique was invented in 1981 by Gerd Binnig and Heinrich Rohrer at IBM in Zurich, Switzerland. For this development Binnig and Rohrer received the Nobel Prize in Physics in 1986.

Function principle: the electron cloud associated with metal atoms at a surface extends a very small distance

above the surface. When a very sharp electronically conducting tip, which is a needle which has been treated so that its edge comprises single atoms, is brought sufficiently close to an electronically conducting surface, there is a strong interaction between the electron cloud on the surface and that of the edge of the tip. An electric tunneling current flows when a small voltage difference is applied between the tip and the surface. This tunneling current rapidly increases as the distance between the tip and the surface decreases. This pronounced dependence of the tunneling current with distance results in atomic resolution, when the tip is scanned over the surface to produce an image (i.e., a translation of the tunneling current as a function of the tip's location to a topographic presentation). An STM instrument includes sample or tip holder driven by a piezoelectric crystal (\rightarrow *piezoelectricity*) that enables to move the sample or the tip in XYZ directions in a submicron resolution. A topographic image of a surface at atomic resolution can be obtained by translating the tunneling current to distance or by applying a feedback loop that keeps the current constant by moving the tip or the surface perpendicular to the surface upon scanning.

The electrochemical scanning tunneling microscope (\rightarrow *scanning probe microscopy*) was developed in 1986–89. With ESTM, the structures of surfaces and results of electrochemical reactions at solid–liquid interfaces can be observed at atomic scale. A majority of electrochemical processes occur at electrode–solution interfaces, therefore *in-situ* STM may supply important information on structural and morphological changes due to electrochemical reactions. *In-situ* STM has a major advantage on *ex-situ* measurements, e.g., by scanning electron microscopy (SEM) as it provides true information in real time at atomic scale during the electrochemical reaction. SPM microscopes for electrochemical *in-situ* measurements always include a \rightarrow *potentiostat*- \rightarrow *galvanostat*, electrochemical measurements unit, which is directly connected to the electrochemical cell in which morphology changes are investigated. These systems include also suitable (commercial, built it) electrochemical cells which have 3 electrodes: WE, CE, and RE. In a typical *in-situ* STM experiment, the electrochemical cell (containing 3 electrodes) is assembled in the system and the \rightarrow *working electrode* (WE) is first scanned in its pristine state, dry. Then solution is introduced and the working electrode is scanned by the tip under OCV conditions. The working electrode is then polarized, the electrochemical response is measured, and an STM imaging is obtained simultaneously while the tip is dipped in the solution, and tunneling current is flowing as a result of

a potential difference set between the tip and the WE. See also \rightarrow *scanning probe microscopy*.

Refs.: [i] Spiridis N, Handke B, Slezak T (2004) *J Phys Chem B* 108:14356; [ii] Wierzbinski E, Arndt J, Hammond W (2006) *Langmuir* 22:2426; [iii] Tansel T, Magnussen OM (2006) *Phys Rev Lett, Phys Revolution* 96:026101; [iv] Du S, Cai L, Li Y, Gao D (2006) *IEEE Trans Instrum Meas* 55:507

DA, MK

Stockholm convention — (1953) Rules for the definite description of an \rightarrow *electrochemical cell*.

1. Phase boundaries are indicated with vertical lines:

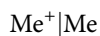

or

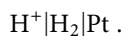

Combination of two half-cells thus yields

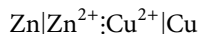

with the \rightarrow *liquid junction* (:) established by the porous separator in the \rightarrow *Daniell cell*.

If both electrodes (\rightarrow *half-cells*) share a phase like, e.g., a common \rightarrow *electrolyte* solution a simplification follows:



2. The \rightarrow *electric potential difference* $\Delta E = U$ is equal in sign and value to the difference between the electrical potentials of the metallic leads on both sides with both leads made of the same metal (in order to avoid \rightarrow *Galvani-potential differences* when different metals are connected). Consequently, the Daniell cell described above should be stated more precisely:

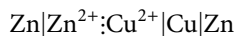

or

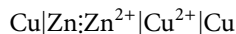

or more generalized with a metal M

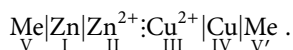

The electrical potential difference $\Delta E = U$ is equal to the sum of the Galvani-potential differences between all participating phases, the Daniell cell is given by

$$\Delta E = (E^{\text{V}'} - E^{\text{IV}}) + (E^{\text{IV}} - E^{\text{III}}) + (E^{\text{III}} - E^{\text{II}}) + (E^{\text{II}} - E^{\text{I}}) + (E^{\text{I}} - E^{\text{V}})$$

or

$$\Delta E = E^{V'} - E^V .$$

3. When positive charge (electricity) is flowing from left to right in the described cell (i.e., ionic flow!), the cell reaction will be

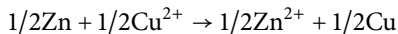

and

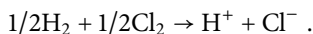

If this direction of current flow coincides with the direction upon short-circuiting the cell the electrical potential difference will be counted positive. Accordingly, the electron-releasing anode is placed left, the electron-consuming cathode is placed right.

4. The value of the electrical potential difference measured without any current flowing (obtained by extrapolation to zero current) will be called \rightarrow *electromotive force* $\Delta E = U$.

See also \rightarrow *cell diagram*.

Refs.: [i] Mills I, Cvitas T, Homann K, Kallay N, Kuchitsu K (eds) (1993) *IUPAC quantities, units and symbols in physical chemistry*. Blackwell Science, London; [ii] van Rysselberghe P (1954) *Z Elektrochem* 58:530

RH

Stöhrer's battery — This was a chromic acid (carbon electrode) – zinc \rightarrow *battery* with a mechanism to control the depth of immersion of electrodes in the electrolyte. See also \rightarrow *chromic acid battery*, \rightarrow *Daniell cell*, \rightarrow *zinc*, \rightarrow *Zn²⁺/Zn electrodes*, \rightarrow *Zn²⁺/Zn(Hg) electrodes*, \rightarrow *zinc-air batteries (cell)*, and \rightarrow *Leclanché cell*.

Ref.: [i] Hauck WP (1883) *Die Galvanischen Batterien, Accumulatoren und Thermo Säulen*, 2nd edn. Hartleben's Verlag, Wien

FS

Stoichiometric number — The concept of stoichiometric number, introduced by \rightarrow *Horiuti* and *Ikusima* in 1939, was initially applied to reactions associated with the synthesis of NH₃. In electrochemistry, stoichiometric number was used in the kinetics of \rightarrow *hydrogen* and oxygen evolution. Generally, stoichiometric number of a substance B is the ν_B coefficient in the stoichiometric equation of the multistep \rightarrow *chemical reaction*

$$0 = \sum_B \nu_B B$$

whose rate is described by

$$d\xi/dt = \nu_B^{-1} dn_B/dt$$

where n_B is the amount of substance B and ξ is the extent of reaction defined by

$$d\xi = \nu_B^{-1} dn_B .$$

This definition is independent of the choice of B and is valid regardless of the conditions, under which a reaction is carried out. For instance, it is valid for a reaction, in which the volume varies with time, or for a reaction involving two or more phases, or for a reaction carried out under flow conditions. The stoichiometric number indicates how many times a rates limiting step must occur for the overall reaction to occur once.

In electrochemical reactions, the stoichiometric number ν , is related to the \rightarrow *transfer coefficient* of the forward, $\bar{\alpha}$, and backward reaction, $\bar{\alpha}'$,

$$\bar{\alpha} + \bar{\alpha}' = n/\nu ,$$

where n is the number of reaction steps. Under low-field approximation of the \rightarrow *Butler-Volmer equation* for a multistep electrochemical reaction, current is inversely proportional to its stoichiometric number

$$j = j_0 \frac{nF\eta}{\nu RT} ,$$

where j_0 is the \rightarrow *exchange current density* and η is \rightarrow *overpotential*.

Refs.: [i] *Horiuti* J, *Ikusima* M (1939) *Proc Imp Acad Tokyo* 15:39; [ii] *IUPAC Manual* (1979) *Pure Appl Chem* 51:1; [iii] *Parsons* R (1974) *Pure Appl Chem* 37:505; *Parsons* R (1979) *Pure Appl Chem* 52:233; [iv] *Bockris* JO'M, *Reddy* AKN, *Gamboa-Aldeco* M (2000) *Modern Electrochemistry*, vol. 2A. *Fundamentals of electrodicts*. Kluwer, New York; [v] *Bockris* JO'M, *Kham* SUM (1993) *Surface electrochemistry*. Plenum, New York

WK

Stoichiometry — A quantitative relationship between the amounts (moles) of reagents that react together and the amounts (moles) of products that are formed in a simple reaction. The term is also used to indicate the respective molar proportions of elements in a chemical compound [i].

Ref.: [i] *Brown* TE, *LeMay* HE, *Bursten* BE (2005) *Chemistry: the central science*. Prentice Hall, New Jersey

FG

Stokes-Einstein equation — *George Gabriel Stokes* (1819–1903) deduced an expression for the frictional coefficient (f_s) in liquids [i]:

$$f_s = 6\pi\eta r_i \quad (1)$$

and → *Einstein* derived a relationship between f_s and the → *diffusion coefficient* (D_i):

$$D_i = \frac{k_B T}{f_s} . \quad (2)$$

The combination of the two equations is called as the Stokes–Einstein equation:

$$D_i = \frac{k_B T}{6\pi\eta r_i} , \quad (3)$$

where k_B is the → *Boltzmann constant*, T is the temperature, η is the → *viscosity* of the medium, and r is the radius of the diffusing particle i .

Refs.: [i] *Stokes GG (1845) Trans Camb Philos Soc VIII:287*; [ii] *Einstein A (1905) Ann Phys 17:549*; [iii] *Bird RB, Stewart W, Lightfoot EN (2002) Transport phenomena, 2nd edn. Wiley, New York, p 529*; [iv] *Erdey-Grúz T (1972) Transport phenomena in aqueous solutions. Hilger, London, pp 149–155*

GI

Stokes' viscous force — The Stokes viscous force relevant to electrochemistry is the force acting on a sphere in the medium with → *viscosity*, η . When the sphere in radius a moves at the constant speed v , the force is given by $6\pi\eta av$. This equation is valid for $2av\rho/\eta < 0.1$ for the density ρ , of the medium [i]. The force is often supplied by diffusion and an electric field.

See → *Nernst–Planck equation*, → *diffusion*, → *Stokes–Einstein equation*.

Ref.: [i] *Bird RB, Armstrong RC, Hassager O (1987) Dynamics of polymeric liquids, vol. 1. Wiley, New York, example 1.4–3*

KA

Stoney's equation → *bending beam method*

Stranski, Iwan Nicolá



(Courtesy of TU Berlin)

(Jan. 2, 1897, Sofia, Bulgaria – June 19, 1979, Sofia, Bulgaria) The son of a Bulgarian father and a German mother, Stranski studied chemistry in Vienna and

Berlin, where he received his Ph.D. in 1925. In 1926 he habilitated for physical chemistry in Sofia, where he became extraordinary Professor in 1926, and full Professor in 1937. In 1930/31 he worked as a Rockefeller scholar at the TH Berlin, and in 1935/36 at the Technical Institute of the Ural in Sverdlovsk, USSR (now Ekaterinburg, Russia). He was Guest Professor in Breslau from 1941 to 1944 and then went to the Kaiser-Wilhelm-Institut of Physical Chemistry and Electrochemistry in Berlin. From 1945 until 1963 he was Professor at the Technical University of Berlin (West-Berlin). Stranski made fundamental contributions to the theory of crystal growth and surface chemistry (see → *Stranski–Krastanov heteroepitaxial metal deposition*) and [ii].

Refs.: [i] *Lacmann R (1981) Z Kristallogr 156:167*; [ii] *Kaischew R (1981) J Cryst Growth 51:643*; [ii] *Kaischew R (1981) J Crystal Growth 51:643*

FS

Stranski–Krastanov heteroepitaxial metal deposition → *epitaxial metal deposition*

Streaming potential → *electrokinetic effects*

Streaming mercury electrode (mercury jet electrode)

— The first type of streaming electrode (*Strahlelektrode*), in which a thin compact stream of mercury flew from a vertical capillary tube down and dispersed into droplets just before entering the solution, was used

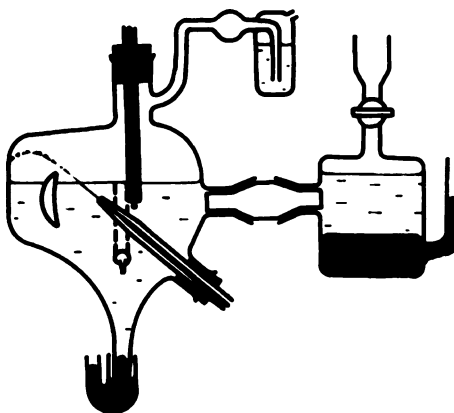

Streaming mercury electrode (mercury jet electrode) — **Figure.** In the *left part* a streaming mercury electrode is shown together with a dropping mercury electrode, and in the *right part* a large mercury pool (e.g., cadmium amalgam) with a cadmium(II) solution is shown which served as counter electrode having a constant potential. The high currents at the streaming mercury electrode afforded such high surface area counter electrode (reference electrode). (Reproduced from [vii])

by Friedrich Paschen [1] when he tried to determine the electric charge of a dropping mercury electrode. Another streaming mercury electrode was introduced by → Heyrovský, J. and J. Forejt [i–iii] to allow measurements with a mercury electrode of constant electrode surface area, which, however, is constantly renewing. A mercury jet issuing upwards from a capillary (see figure) is forming a cylindrical electrode as long as it passes through the solution. Compared to a → *dropping mercury electrode* the streaming mercury electrode needs a wider capillary with a conical tip. The streaming electrode was used for → *oscillopolarography*, and other variants of → *polarography*. Electrodes with a streaming-down mercury column have been also published [iv–vi], although their properties are inferior. See also → *electrode materials*, subentry → *mercury*.

Refs.: [i] Paschen F (1890) *Wied Ann Phys* 41:42; [ii] Heyrovský J, Forejt J (1943) *Z physik Chem* 193:77; [iii] Heyrovský J (1946) *Chem Listy* 40:222; [iiii] Heyrovský J, Šorm F (1947) *Collect Czechoslov Chem Commun* 12:11; [iv] Rfús A, Llopis J (1946) *An Fisica Quím* 42:617; [v] Koryta J (1957) *Chem listy* 49:485; [vi] Koryta J (1958) *Collect Czechoslov Chem Commun* 20:1125; [vii] Heyrovský J, Kůta J (1965) *Grundlagen der Polarographie*. Akademie Verlag, Berlin, p 30

S

Stress reducers → *electroplating additives*

Stripping analysis → *stripping voltammetry*

Stripping potential → *potential*

Stripping voltammetry — Refers to a family of procedures involving a → *preconcentration* of the → *analyte* (or a salt or derivative of the analyte) onto (or into) the → *working electrode* prior to its direct or indirect determination by means of an electroanalytical technique [i–iv]. See also → *adsorptive stripping voltammetry*, → *anodic stripping voltammetry*, → *cathodic stripping voltammetry*.

Refs.: [i] Fogg AG, Wang J (1999) *Pure Appl Chem* 71:891; [ii] Vydra F, Stulik K, Julakova E (1976) *Electrochemical stripping analysis*. Halsted Press, New York; [iii] Wang J (1985) *Stripping analysis*. VCH, Deerfield Beach; [iv] Lovrić M (2002) *Stripping voltammetry*. In: Scholz F (ed) *Electroanalytical methods*. Springer, Berlin, pp 191–210

AMB

Stromberg, Armin Genrikhovich



(Sep. 16, 1910, Breslau, then Germany, now Wrocław, Poland – Sep. 18, 2004, Tomsk, Russia) Russian electrochemist. From 1927–30 studies at the Ural Industrial Institute, 1939 Ph.D., 1942–43 detained by the NKVD in the GULAG in a German group in a brick factory in Nizhnii Tagil because of his German ancestry. He was rehabilitated in 1992. In 1951 he defended his “doctor nauk” thesis (equivalent to a habilitation) entitled “Theory and practice of → *polarography* and especially of amalgam polarography”. In 1954 he became professor of physical and colloidal chemistry at the Ural State University in Sverdlovsk (now Ekaterinburg). 1956–1985 chair of physical and colloidal chemistry at Tomsk Polytechnical University, Tomsk. Stromberg supervised 86 Ph.D. students, published 430 papers and 8 textbooks (among which are 5 editions of “Physical Chemistry”). Stromberg is best known for his numerous contributions to → *stripping voltammetry*.

Refs.: [i] Bakibaev AA (ed) (2005) *Istorija kafedry fizicheskoj i analiticheskoj khimii (1900–2004)*. TPU Publisher, Tomsk; [ii] Morachevskii AG, Lvov BV, Kravtsov VI (2004) *Russ J Appl Chem (Engl ed)* 77:1913; [iii] *Chronicle* (2005) *J Anal Chem (Engl ed)* 60:496

FS

Stuart cell — Monopolar water → *electrolysis* tank cell employing plate electrodes with those of the same polarity connected in parallel resulting in a cell voltage of 1.7–2 V. Cells are connected in series, the inherent drawbacks of cells of the filterpress design (e.g., complicated sealing and interconnect devices) are avoided.

Ref.: [i] Pletcher D, Walsh FC (1993) *Industrial electrochemistry*. Blackie Academic & Professional, London

RH

Sub-nerstian slope — An → *ion-selective electrode* is said to have a sub-nerstian slope when the slope of the linear part of the calibration plot of the potential vs. the

logarithm of the \rightarrow activity (a_i) of a given ion i with charge z_i is (significantly) smaller than $2.303(RT/z_iF)$ (59.16/ z_i mV per unit of $\log a_i$ at 25 °C). Analogously, a slope equal to $2.303(RT/z_iF)$ is said to be a \rightarrow *nernstian slope*. The sub-nernstian slope of \rightarrow *glass electrodes* and other \rightarrow *membrane electrodes* may be attributed to the influence of ion activity (a_i) on the \rightarrow *dissociation* of functional groups at the membrane surface in contact with the solution. See also \rightarrow *Nernst equation*, \rightarrow *potentiometry*.

Refs.: [i] (1976) *Pure Appl Chem* 48:127; [ii] Baucke FGK (1994) *Anal Chem* 66:4519

Subsequent chemical reactions in electrochemistry

\rightarrow *chemical reactions in electrochemistry*

Substrate configuration — Terminology used in \rightarrow *photovoltaic devices* to designate the device architecture in which the light enters the device through the top face of the cell, i.e., oppositely to the substrate.

Ref.: [i] Meyer TB, Meyer AF, Ginestoux D (2001) *Flexible solid-state dye solar cells*. In: Kafafi ZH (ed) *Organic photovoltaics II*. SPIE – The International Society for Optical Engineering, Washington, pp 13–20

JB

IH

Sulfur — Elemental sulfur dissolved in dimethylsulfoxide can be reduced on a gold \rightarrow *electrode* to polysulfide \rightarrow *anion*: $S_8 + e^- \rightleftharpoons S_8^-$ ($E_{1/2} = -0.4$ V vs. SCE) and $S_8^- + e^- \rightleftharpoons S_8^{2-}$ ($E_{1/2} = -1.22$ V vs. SCE). Both reactions are kinetically controlled and complicated by the dimerization: $2S_8^- \rightarrow (S_8)_2^-$ [i].

Hydrogen sulfide can be \rightarrow *oxidized* to sulfur ($HS^- \rightarrow S + 2e^- + H^+$) on a platinum electrode at +0.5 V vs SCE. The electrode reaction is followed by the formation of \rightarrow *disulfide* ($HS^- + S \rightarrow HS_2^-$) and polysulfide anions ($HS^- + xS \rightarrow HS_{x+1}^-$). At potentials higher than +1 V on platinum electrode sulfides and polysulfides are oxidized to \rightarrow *sulfate* ($S^{2-} + 8OH^- \rightarrow SO_4^{2-} + 8e^- + 4H_2O$) and thiosulfate anions ($S_x^{2-} + 6OH^- \rightarrow S_2O_3^{2-} + 6e^- + 3H_2O + (x-2)S$) [ii].

Thiosulfate dissolved in 1 mol L⁻¹ NaOH can be reduced on a platinum electrode to sulfide and sulfite: $S_2O_3^{2-} + 2e^- \rightarrow S^{2-} + SO_3^{2-}$ ($E_{1/2} = -1.9$ V vs. SCE). Under these conditions thiosulfate can be oxidized to dithionate ($2S_2O_3^{2-} \rightarrow S_2O_6^{2-} + 2S + 4e^-$; $E_{1/2} = +1$ V vs. SCE) and sulfate anions ($S_2O_3^{2-} + 10OH^- \rightarrow 2SO_4^{2-} + 8e^- + 5H_2O$; $E_{1/2} = +1.2$ V) [iii].

Sulfur dioxide dissolved in water can be oxidized on a platinum electrode to sulfate anion: $SO_2 + 2H_2O \rightarrow SO_4^{2-} + 2e^- + 4H^+$ ($E_{1/2} = +0.45$ V vs. SCE), and reduced

to dithionite anion: $2SO_2 + 2e^- \rightleftharpoons S_2O_4^{2-}$ ($E_{1/2} = -0.41$ V vs. SCE).

In the presence of hydrogen sulfide anions, a film of insoluble HgS is formed on the surface of the mercury electrode: $Hg + HS^- \rightleftharpoons HgS + H^+ + 2e^-$ ($E_{1/2} = -0.702$ V vs. SCE, at pH 10 and $[Na_2S] = 2 \times 10^{-4}$ mol L⁻¹). This reaction is the basis for electroanalytical determination of sulfides and thiols ($2Hg + 2R-SH \rightleftharpoons (R-S-Hg)_2 + 2H^+ + 2e^-$) by \rightarrow *cathodic stripping voltammetry*.

Thiols are the sulfur analogs of alcohols. They have high binding energy to a gold surface and form self-assembled monolayers, which are molecular assemblies that are prepared by spontaneous adsorption of thiols from solution onto a gold substrate [i, iii].

Refs.: [i] Demortier A, Lelieur J-P, Levillain E (2006) *Sulfur*. In: Bard AJ, Stratmann M, Scholz F, Pickett CJ (eds) *Inorganic electrochemistry*. Encyclopedia of electrochemistry, vol. 7a. Wiley-VCH, Weinheim, p 253; [ii] Steudel R (2003) *Elemental sulfur and sulfur-rich compounds*. Springer, Berlin; [iii] Zhdanov SI (1975) *Sulfur*. In: Bard AJ (ed) *Encyclopedia of electrochemistry of the elements*, vol. IV. Marcel Dekker, New York, p 273

SKL

Disulfides — A disulfide bond (R-S-S-R) is a strong covalent bond formed by the oxidation of two sulfhydryl groups (R-S-H). An amino acid that commonly forms S-S bonds in proteins is cysteine. When two cysteines are bonded by an S-S bond, the resulting molecule between the two protein chains is called cystine. The presence of disulfide bonds helps to maintain the tertiary structure of the protein. Industrial production of L-cysteine is based on the electrochemical \rightarrow *reduction* of L-cystine in acidic \rightarrow *electrolytes* using lead or silver \rightarrow *cathodes*.

Ref.: [i] Ralph TR, Hitchman ML, Millington JP, Walsh FC (2005) *J Electrochem Soc* 152:D54

SKL

Peroxodisulfate — Peroxodisulfuric acid ($H_2S_2O_8$) is prepared through the \rightarrow *electrolysis* of concentrated \rightarrow *sulfuric acid* with a smooth platinum \rightarrow *anode*. The \rightarrow *standard potential* of the redox reaction $2SO_4^{2-} \rightleftharpoons S_2O_8^{2-} + 2e^-$ is $E^\ominus = +2.05$ V vs. SHE. Electrode \rightarrow *oxidation* of sulfate anions includes an intermediate SO_4 adsorbed on the platinum surface and its reaction with SO_4^{2-} anion to give $S_2O_8^{2-}$ anion. The first electron transfer ($Pt + SO_4^{2-} \rightarrow Pt(SO_4^-)_{ads} + e^-$) is the rate-determining step of the electrooxidation [i]. Platinum anode is used because of its high oxygen overpotential. The \rightarrow *anolyte* and \rightarrow *catholyte* are separated by a \rightarrow *diaphragm* because peroxodisulfuric acid easily undergoes \rightarrow *reduction*. The \rightarrow *half-wave potential* of the electrode reduction $S_2O_8^{2-} + 2e^- \rightarrow 2SO_4^{2-}$

is $E_{1/2} = +0.34$ V vs. SCE [ii]. The reaction is totally \rightarrow irreversible, with the first electron transfer ($S_2O_8^{2-} + e^- \rightarrow SO_4^{2-} + SO_4^-$) being the rate-determining step [iii].

Refs.: [i] Smith W, Hoogland JG (1971) *Electrochim Acta* 16:981; [ii] Kryukova TA (1949) *Dokl Akad Nauk SSSR* 65:517; [iii] Giebler E, Kirmse H (2005) *J Appl Electrochem* 35:985

ŠKL

Sulfuric acid — This is the most important sulfur compound. It is produced by the catalyzed \rightarrow oxidation of SO_2 and dissolution of SO_3 in 98% H_2SO_4 , followed by dilution with \rightarrow water. Electroreduction of sulfate anion was observed during the \rightarrow electrolysis of aqueous solutions of sulfuric acid at temperatures higher than 50 °C, and the electrolysis of fuming sulfuric acid at room temperature. Apart from the evolution of hydrogen, the products of \rightarrow cathode reactions are sulfur dioxide and sulfur. It is believed that the dissolved sulfur trioxide is reduced by the hydrogen atoms adsorbed on platinum \rightarrow electrode ($SO_3 + 2H_{ads}/Pt \rightarrow SO_2 + H_2O + Pt$) and that the product of this \rightarrow reduction is further reduced to sulfur ($SO_2 + 4H_{ads}/Pt \rightarrow S + 2H_2O + Pt$). At increased temperature, SO_3 can be formed by the thermal decomposition of 98% sulfuric acid.

Ref.: [i] Arvia AJ, Carrozza JSW, Garrera HA (1971) *Electrochim Acta* 16:79

ŠKL

Thiocyanate — Thiocyanate (SCN^-) \rightarrow anions can be found in industrial wastewaters, pesticide residues, and organism metabolites. They can be determined by \rightarrow ion-selective electrodes based on a variety of carriers such as organometallic compounds and metalloporphyrin derivatives. Also, SCN^- forms \rightarrow complexes with metal \rightarrow ions (e.g., $Ag(SCN)_2^-$) and influences the responses of metal ions in \rightarrow cyclic voltammetry.

Ref.: [i] Wang G-F, Li MG, Gao Y-C, Fang B (2004) *Sensors* 4:147

ŠKL

Sulfur–Sodium battery \rightarrow sodium–sulfur battery

Sum frequency generation \rightarrow spectroscopy

Superacid (also called magic acid) — This term was introduced by Hall and Conant in 1927 [i–ii] for acids that are stronger than the strongest acids in aqueous systems. Gillespie [iii–iv] defined superacids as being stronger than 100% sulfuric acid, i.e., acids with values $H_0 \leq -12$ (H_0 is the \rightarrow Hammett acidity function). Superacids are able to protonate extremely weak bases. Fluorosulfuric acid HSO_3F and trifluoromethanesulfonic acid CF_3SO_3H are superacids, and the cationic product

$[H_2SO_3F]^+$ of the following reaction: $2HSO_3F + SbF_5 \rightleftharpoons [H_2SO_3F]^+ + [SbF_5OSO_2F]^-$ is an even stronger superacid. Superacids can be formed by reaction of two different Brønsted acids (\rightarrow acid–base theories), or by reaction of a Brønsted acid with a Lewis acid (e.g., SbF_5 in the given example). Superacids became famous with the work of George Andrew Olah (Nobel Prize in Chemistry in 1994) who showed that they are able to produce carbocations [v]. See also \rightarrow super base.

Refs.: [i] Hall NF, Conant JB (1927) *J Am Chem Soc* 49:3047; [ii] Conant JB, Hall NF (1927) *J Am Chem Soc* 49:3062; [iii] Gillespie RJ, Peel TE (1972) *Adv Phys Org Chem* 9:1; [iv] Gillespie RJ, Peel TE (1973) *J Am Chem Soc* 95:5173; [v] Olah GA, Prakash GKS, Sommer J (1985) *Superacids*. Wiley, New York

FS

Superbase — This term is used for reagents which possess an extremely strong \rightarrow proton affinity. Alkali-organyls, e.g., butyl-potassium, and methyl-lithium are examples for that group. Superbases have been known since the mid-19th century; however, the name has been only created following the discovery of \rightarrow superacids. See also \rightarrow acid–base theories.

Ref.: [i] Bauer W, Lochmann L (1997) *J Am Chem Soc* 114:1482

FS

Supercapacitors — (also known as electric \rightarrow double layer (EDL) capacitors) are an important development in the field of energy storage and conversion. Unlike \rightarrow batteries, where energy conversion is obtained via electrochemical \rightarrow redox reactions, supercapacitors are based on electrostatic interactions occurring at the electrode–solution \rightarrow interface. During the storage of electrochemical energy in a battery, chemical interconversions of the electrode materials usually occur with concomitant \rightarrow phase transitions. Although the overall energy changes can be conducted in a relatively reversible thermodynamic route, charge and discharge processes in a storage battery often involve irreversibility in interconversions of the chemical electrode-reagents. Accordingly, the \rightarrow cycle life of storage in batteries is usually limited. In EDL capacitors, the energy is stored in electrostatic interactions, which are much less detrimental to the electrode surface structure and to the electrolyte solution compared to faradaic red–ox processes. Hence, capacitors can undergo unlimited cycles of charge–discharge without deterioration (typically in the order of 10^6 cycles). When compared with batteries, capacitors can store only a small amount of charge (one order at least smaller, compared to battery capacities). In order to increase the energy density of su-

percapacitors, high-surface-area electrodes, such as activated \rightarrow *carbons*, aerogels, and felt, with an accessible surface area of 1000–2000 m² g⁻¹, capacitances of 100 F g⁻¹, are the most common materials for supercapacitors. Another advantage of the supercapacitor is its high power and high charging rate in comparison with batteries.

There are two types of supercapacitors: the first one involves the charging and discharging of the electrical double-layer interface, while in the second one, the charge–discharge is accompanied by \rightarrow *electron transfer*, yet with no phase changes, as is the case in batteries. The latter is also referred to as a pseudocapacitor. The \rightarrow *capacitance* of such a supercapacitor is $C = C_{dl} + C_{\theta}$, where C_{dl} represents the double-layer capacitance and C_{θ} represents the pseudocapacitance.

A typical supercapacitor is composed of three basic elements: \rightarrow *electrodes*, \rightarrow *electrolyte solution*, and \rightarrow *separator*. The key features that are vital for the electrode of a supercapacitor are cycleability, stability, and high surface area. In recent years, the development of commercial supercapacitors has focused on using high-surface-area electrodes. Carbonaceous materials, owing to their high surface area and low electronic resistance, were studied intensively. Capacities as high as 500 F g⁻¹ have been reported in alkaline solutions. RuO₂ and IrO₂ yield capacitances of approximately 250 μ F cm⁻², while the capacity of carbon electrodes is in the range of 10–50 μ F cm⁻², depending on the electrode precursor and type of electrolyte solution employed. The huge capacitances of the above-mentioned metal oxides probably result from the interaction of metal oxide surface with protons from the solution. Capacities as high as 770 F g⁻¹, have been reported when porous RuO_x \times H₂O electrodes were used. Other types of electrode materials that demonstrate pseudocapacitance are electronically \rightarrow *conducting polymers*. Wide electrochemical windows can be achieved with conducting polymers such as polythiophenes in aprotic electrolyte solutions. However, the stability and cycleability of most electronically conducting polymers are limited. Recently, new types of materials, such as iron, titanium, molybdenum, and carbon nanotubes have been suggested as materials for electrodes in supercapacitors.

The capacitance of carbon electrodes in acidic and alkaline solutions is quite high, yet the narrow electrochemical window of aqueous solutions is a main disadvantage when used in supercapacitors. Hence, it is possible to increase the \rightarrow *energy density* of supercapacitors by enlarging their working potential window. For that, polar aprotic solutions can be suitable. Indeed, many aprotic

\rightarrow *solvents* such as propylene carbonate (PC), tetrahydrofuran (THF), acetonitrile, etc. have been studied with carbon electrodes in connection with R&D of high voltage, high energy density supercapacitors. LiClO₄, NaClO₄, LiAsF₆, BF₄⁻, CF₃SO₃⁻ have been used as electrolytes in aprotic solvents.

In conclusion, supercapacitors are robust devices better capable of energy storage in electrical vehicle applications, backups, and highly reversible power sources for computer storage, than conventional capacitors. For the former application, supercapacitors can be a part of hybrid power sources, which also include high-energy-density batteries in which the supercapacitors provide the high power required.

See also \rightarrow *ultracapacitor*.

Refs.: [i] Nishino A (1996) *J Power Sources* 60:137; [ii] Yata S, Okamoto E, Satake H, Kobota H, Fujii M, Taguchi T, Kinoshita H (1996) *J Power Sources* 60:207; [iii] Shukla AK, Sampath S, Vijayamohanan K (2000) *Curr Sci* 79:656; [iv] Pell W, Conway BE (2001) *J Power Sources* 96:57; [v] Ryu KS, Lee YG, Park YJ, Wu XL, Kim KM, Kang MG, Park NG, Chang SH (2004) *Electrochim Acta* 50:843; [vi] Pornsin-Sirirak TN, Tai YC, Nassef H, Ho CM (2001) *Sensors Actuat A-Phys* 89:95; [vii] Liu TC, Pell WG, Conway BE, Roberson SL (1998) *J Electrochem Soc* 145:1882; [viii] Honda K, Yoshimura M, Kawakita K, Fujishima A, Sakamoto Y, Yasui K, Nishio N, Masuda H (2004) *J Electrochem Soc* 151:A532; [ix] Bagotsky VS (2006) *Fundamentals of electrochemistry*, 2nd edn. Wiley Interscience, Hoboken, pp 369

DA

Superionics — called also superionic conductors or fast \rightarrow *ionic conductors*, are a group of solid materials with a high ionic \rightarrow *conductivity* ($>10^{-2}$ – 10^{-1} S m⁻¹). This state is characterized by the rapid \rightarrow *diffusion* of a significant fraction of one of the constituent species (mobile \rightarrow *ions*) within an essentially rigid framework formed by other components, typically at elevated temperatures. In many cases, the superionic state is considered as intermediate between normal solids and liquid \rightarrow *electrolytes*.

There is no strict boundary between superionic and other ion conductors. In the literature the level of ionic conductivity accepted as such boundary varies from 10⁻¹ to 10 S m⁻¹.

Often this term is used for \rightarrow *solid electrolytes* and/or for solids with structural disorder (see \rightarrow *defects in solids*), although all these designations are not synonyms. The high concentration of defects, necessary for fast ionic conduction, may be induced by external factors such as \rightarrow *doping*, electromagnetic forces, radiation, etc. Creation of these defects may lead to the generation of \rightarrow *electron* \rightarrow *charge carriers* and, thus, induce electronic \rightarrow *conductivity*.

Considering the appearance of superionic state on heating, the superionic conductors may be classified into three groups [i]. Type-I conductors become superionic at temperatures above a first-order \rightarrow *phase transition*, leading to a structurally disordered state (for example, α -phase of AgI or δ -phase of \rightarrow *bismuth oxide*). Type-II materials, such as β -PbF₂, attain high levels of ionic transport following a gradual and continuous disordering process within the same phase. The concentration of mobile ionics tends to saturation at the so-called superionic transition, accompanied often by an anomaly in the specific heat and lattice expansion. The superionic conductors of Type III do not show a clear phase transition. These achieve a high ionic conductivity due to exponential rise of the ion mobility with temperature, whereas the number of thermally activated defects is generally fixed. Examples of Type-III superionic conductors are \rightarrow *stabilized zirconia*, doped \rightarrow *cerium dioxide*, and \rightarrow *β -alumina*.

Refs.: [i] Boyce JB, Huberman BA (1979) *Phys Rep* 51:189; [ii] Rickert H (1982) *Electrochemistry of solids. An introduction*. Springer, Berlin

VK

S

Supersaturation — The general thermodynamic definition of the electrochemical supersaturation $\Delta\bar{\mu}$ reads

$$\Delta\bar{\mu} = \bar{\mu}_s - \bar{\mu}_{c,\infty} > 0, \quad (1)$$

where $\bar{\mu}_s$ is the \rightarrow *electrochemical potential* of the parent phase, the \rightarrow *electrolyte solution* with an \rightarrow *activity* a_s , and $\bar{\mu}_{c,\infty}$ is the electrochemical potential of the atoms in the bulk crystalline or liquid new phase.

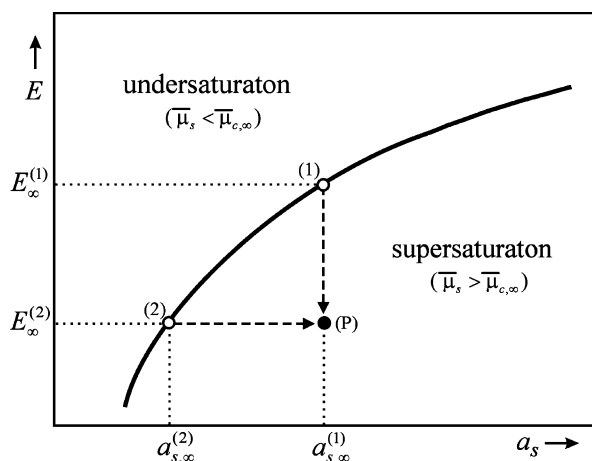

Supersaturation — Figure. Schematic $E(a_s)$ diagram for the equilibrium of a bulk liquid or crystalline phase with its own ionic solution [i]

In Fig. 1 the supersaturation range is located below the equilibrium curve corresponding to the equality $\bar{\mu}_{s,\infty} = \bar{\mu}_{c,\infty}$. In the case when $\bar{\mu}_s < \bar{\mu}_{c,\infty}$, the difference $\bar{\mu}_s - \bar{\mu}_{c,\infty} < 0$ defines the electrochemical undersaturation, which, if applied, would cause the electrochemical dissolution of the bulk liquid or crystalline new phase. Thus, the quantity $\Delta\bar{\mu}$ defines the thermodynamic driving force of the two opposite types of electrochemical first-order \rightarrow *phase transition* and it is of fundamental importance to express it by means of physical quantities, which can be easily measured and controlled.

The general formula for $\Delta\bar{\mu}$ that is most frequently used reads

$$\Delta\bar{\mu} = ze\eta, \quad (2)$$

where η is the \rightarrow *overpotential* defined either as

$$\eta = E_\infty - E \quad (3)$$

or as

$$\eta = \frac{kT}{ze} \ln \frac{a_s}{a_{s,\infty}}. \quad (4)$$

Equations (3) and (4) show that the parent phase can be supersaturated with respect to the bulk new one in two different ways, as illustrated schematically in Fig. 1. In the first way, the solution activity a_s is kept constant at the value $a_{s,\infty}^{(1)}$ and the state of the system is changed from the equilibrium point (1) to a point (P) located in the supersaturation range by changing the electrode potential from the equilibrium, $E_\infty^{(1)}$, to a more negative value $E \equiv E_\infty^{(2)}$. At this potential the bulk crystalline or liquid phase should stay in equilibrium with a solution having an activity $a_{s,\infty}^{(2)} < a_{s,\infty}^{(1)}$. In the second way, the parent phase is supersaturated to the same state (P) but starting from the equilibrium state (2) and increasing the solution activity to a value $a_s = a_{s,\infty}^{(1)}$ larger than the equilibrium value $a_{s,\infty}^{(2)}$, the \rightarrow *electrode potential* E being kept constant at $E_\infty^{(2)}$. See also \rightarrow *oversaturation*.

Refs.: [i] Staikov G, Milchev A (2007) *The impact of electrocrystallization on nanotechnology*. In: Staikov G (ed) *Electrocrystallization in nanotechnology*. Wiley-VCH, Weinheim; [ii] Budevski E, Staikov G, Lorenz WJ (1996) *Electrochemical phase formation: an introduction to the initial stages of metal deposition*. VCH, Weinheim; [iii] Milchev A (2002) *Electrocrystallization: fundamentals of nucleation and growth*. Kluwer, Boston

AM

Superstrate configuration — Terminology used in \rightarrow *photovoltaic devices* to designate the device architec-

ture in which the light enters the device through the substrate, which is then a transparent substrate covered with a transparent conductive layer.

Ref.: [i] Meyer TB, Meyer AF, Ginestoux D (2001) *Flexible solid-state dye solar cells*. In: Kafafi ZH (ed) *Organic photovoltaics II*. SPIE – The International Society for Optical Engineering, Washington, pp 13–20

IH

Supporting electrolyte → *inert electrolyte*

Supramolecular electrochemistry → *electrochemistry of molecular superstructures composed of weakly bonded smaller units (molecules, ions). The superstructure is held together by noncovalent interactions, such as → van der Waals forces, hydrophobic interactions, → hydrogen bonding, π – π interactions, metal coordination, and electrostatic forces. The design of these weakly bonded molecular superstructures was initially intended to mimic the behavior of biological assemblies (e.g., guest–host superstructures with biorecognition capabilities) providing a wealth of functionalities not achievable with covalently bonded molecules, e.g., ion-channel proteins embedded in lipid bilayers or double-stranded DNA (two strands held together by hydrogen bonding). The supramolecular electrochemistry offers a design and characterization of new nanomaterials with unique catalytic properties, sensory materials including biorecognition assemblies, self-healing polymeric and anti-corrosion films, light-harvesting dye aggregates for solar cells, magnetic functionalized nanoparticles, etc. Large molecules used to design supramolecular assemblies include → carbon nanotubes, → fullerenes, → porphyrines, polypeptides, transition metal complexes, and many other compounds. The supramolecular assemblies may also be based on networks of core-shell → metal or → semiconductor nanoparticles showing unique magnetic, optical, sensory, and electrocatalytic properties (e.g., for methanol oxidation in → fuel cells). The supramolecular studies of CdSe and other quantum dots capped with dithiolate molecules contacting drain and source electrodes have demonstrated single electron charging/discharging processes. One configuration of this type is a capped Au nanoparticle with attached fluorophore placed between a single crystal Au(111) sample surface and the STM tip, where the modulation of fluorophore properties by controlling Au nanoparticle charging is achieved. Various piezo-biosensors utilizing single-stranded DNA to detect defective genes or used to study drug toxicity are also based on supramolecular interactions.*

Refs.: [i] Ipe BI, George TK, Barazzouk S, Hotchandani S, Kamat PV (2002) *J Phys Chem B* 106:18; [ii] Halamek J, Hepel M, Skladal P (2001) *Biosens Bioelectron* 16:253; [iii] Lehn JM (1993) *Science* 260:1762; [iv] Kaijfer AE, Gomez-Kaijfer M (1999) *Supramolecular Electrochemistry*, Wiley-VCH, New York

MHep

Surface — In physics and chemistry, the term surface means the termination of a solid or liquid phase bordering to vacuum. As this is an almost impossible to realize case (at least the equilibrium vapor phase of the liquid or solid phase will always border to the condensed phase), ‘surface’ means practically always the → *interface* between two phases, i.e., two solid phases, two liquid phases, a solid phase and a liquid phase, a solid phase and a gas phase, or a liquid phase and a gas phase. Hence, the term ‘interface’ should be preferred. Since → *electrodes* are a major field of research in → *electrochemistry* (interfacial electrochemistry) the study of surfaces (interfaces) with respect to their structure, effects on → *electron transfer* and → *ion transfer* reactions, its changes in electrochemical reactions, its → *electrocatalytic* effects, etc. are of major importance.

The general thermodynamic requirement for the stability of an interface between two phases is a positive → *Gibbs energy* of formation, because otherwise the interface would either fluctuate or disappear. Since the molecular forces on either side of an interface possess a specific anisotropy the structure of the utmost surface layers differs from that inside the phases (see → *double layer*). For these interfacial regions the term → *interphase* is also used.

See also → *electrode surface area*, → *Gibbs–Lippmann equation*, → *interfacial tension*, → *interface between two liquid solvents*, → *interface between two immiscible electrolyte solutions* → *Lippmann capillary electrometer*, → *Lippmann equation*, → *surface analytical methods*, → *surface stress*.

Refs.: [i] Adamson AW, Gast AP (1997) *Physical chemistry of surfaces*, 6th edn. Wiley, New York; [ii] Schmickler W (1996) *Interfacial electrochemistry*. Oxford University Press, New York; [iii] Bard AJ, Faulkner LR (2001) *Electrochemical methods. Fundamentals and applications*, 2nd edn. Wiley, New York; [iv] Wieckowski A (ed) (1999) *Interfacial electrochemistry. Theory, experiment, and applications*. Marcel Dekker, New York

FS

Surface-active ligands — are those ligands of a complex molecule or ion through which the complex species adsorbs (see → *adsorption*) on the electrode surface [i]. Most frequently, these are organic ligands containing nitrogen or oxygen as electron-donating atoms

to form stable complexes with metal ions. Besides, inorganic ions such as Cl^- , Br^- , and I^- , form labile complexes with metal ions and induce adsorption of the complexes on the electrode surface (see \rightarrow *anion-induced adsorption*). The adsorption of the complex via the surface-active ligand may proceed through direct adsorption, competitive adsorption, or \rightarrow *surface complexation mechanism* [ii].

Refs.: [i] Wang J (1989) *Voltammetry after nonelectrolytic preconcentration*. In: Bard AJ (ed) *Electroanalytical chemistry*, vol. 16. Marcel Dekker, New York, p 1; [ii] Lovrić M (2002) *Stripping voltammetry*. In: Scholz F (ed) *Electroanalytical methods. Guide to experiments and applications*. Springer, Berlin Heidelberg, p 200

VM

Surface-active substances — are electroactive or electroinactive substances capable to concentrate at the interfacial region between two phases. Surface-active substances accumulate at the electrode–electrolyte \rightarrow *interface* due to \rightarrow *adsorption* on the electrode surface (see \rightarrow *electrode surface area*) or due to other sorts of chemical interactions with the electrode material (see \rightarrow *chemisorption*) [i]. Surface-active substances capable to accumulate at the \rightarrow *interface between two immiscible electrolyte solutions* are frequently termed surfactants. Their surface activity derives from the amphiphilic structure (see \rightarrow *amphiphilic compounds*) of their molecules possessing hydrophilic and lipophilic moieties [ii].

Refs.: [i] Wang J (1989) *Voltammetry after nonelectrolytic preconcentration*. In: Bard AJ (ed) *Electroanalytical chemistry*, vol. 16. Marcel Dekker, New York, p 1; [ii] Kakiuchi T (2001) *Adsorption at polarized liquid–liquid interfaces*. In: Volkov AG (ed) *Liquid interfaces in chemical, biological, and pharmaceutical applications*. Marcel Dekker, New York, p 105

VM

Surface activity — is \rightarrow *activity* of a species i adsorbed (see \rightarrow *adsorption*) on the electrode or activity of species accumulated in the interfacial region between two immiscible liquids (see \rightarrow *interface between two immiscible electrolyte solutions*). Surface activity is related to the activity of species in the bulk of the solution as follows: $a_i^A = a_i^b \exp\left(-\frac{\Delta\tilde{G}_i^\ominus}{RT}\right)$, where a_i^A and a_i^b is the activity of the species in the interfacial region and bulk of the solution, respectively, $\Delta\tilde{G}_i^\ominus$ is the electrochemical standard free energy of adsorption, R is the \rightarrow *gas constant*, and T is thermodynamic temperature.

Ref.: [i] Bard AJ, Faulkner LR (2001) *Electrochemical methods, Fundamentals and applications*. 2nd edn. Wiley, New York, p 566

VM

Surface analytical methods — Important ex situ methods for surface analysis are X-Ray Photoelectron Spectroscopy (XPS) UV–Photoelectron Spectroscopy (UPS), Auger Electron Spectroscopy (AES), Ion Scattering Spectroscopy (ISS), Rutherford Backscattering (RBS), Secondary Ion Mass Spectroscopy (SIMS), Scanning Electron Microscopy (SEM), Electron Microprobe Analysis (EMA), Low Energy Electron Diffraction (LEED), and High Energy Electron Diffraction (RHEED).

Some in situ methods use the intense radiation of synchrotron beamlines. Usually one applies a grazing incidence of monochromatized synchrotron radiation in order to enhance the contribution of the surface and surface films and to suppress that of the bulk material of an electrode. If the energy of the radiation is sufficiently high (>9 keV) and intense it may pass the electrolyte in front of the electrode without too strong losses by absorption. Grazing Incidence X-Ray Diffraction (GIXRD) is used for structural information and Grazing Incidence X-Ray Absorption Spectroscopy (GIXAS) provides both information on the chemistry of the surface and surface layers and their short-range-order structure even of disordered or amorphous materials. Additional in situ information may be achieved by the application of \rightarrow *scanning probe microscopies* (SPM). These SPM-methods provide a direct image of the surface structure for in situ conditions even with atomic resolution. They have been applied for structural investigations of \rightarrow *adsorption* and \rightarrow *underpotential deposition* (UPD), \rightarrow *electrodeposition* of metals, oxide formation (\rightarrow *corrosion*), layers of organic materials on electrodes, \rightarrow *catalysis* and other problems on solid surfaces. One usually uses well-prepared and -oriented single crystal surfaces for these investigations. However, the methods may be applied also to surfaces in industry and applied research especially in the case of SFM [i, ii].

Refs.: [i] Briggs D, Seah MP (1983) *Practical surface analysis*. Wiley, New York; [ii] Marcus P, Mansfeld F (eds) (2006) *Analytical methods in corrosion science and engineering*. Taylor and Francis, Boca Raton

HHS

Auger electron spectroscopy (AES) — When an electron is removed from a level of energy E_1 of a surface atom, the hole is filled by an electron from a higher electronic level E_2 . The energy difference between the two involved orbitals is transferred to a third electron of level E_3 which then leaves the atom and may be measured as an Auger electron. Due to the mean free path of the electrons AES is a surface analytical method with a depth resolution of some few nm as in the case of XPS. The excitation of electrons and the primary ionization process

may be achieved by X-rays which is used for X-ray induced AES or by electrons of an electron source leading to electron-induced AES. Electron beams may be easily focussed to very small spots at a surface which allows a good lateral resolution in the nm-range and a related mapping of element distributions with a scanning electron beam for Scanning AES (SAES). The energy spectrum of the Auger electrons is taken with an electrostatic energy analyzer similar to XPS. A first derivative of the Auger peaks is obtained by the modulation of the pass energy or the retarding voltage of the analyzer together with lock-in technique. The high sensitivity of this method has been applied for the development of AES as a surface analytical method [i]. The kinetic energy of the Auger lines depends on the energy of the three involved electronic levels E_1 to E_3 and is thus characteristic for the elements at the surface and their binding situation. They are usually described by these three involved electronic levels. For a KLL line an electron is ejected from the K shell by the incoming X-rays or electrons and the hole is filled by an electron from the L shell. The energy difference between the K and L shell is used to ionize an additional electron from the L shell, the Auger electron. The excess energy appears as the kinetic energy of the Auger electron. The participation of three electronic levels for the Auger process causes relatively complicated Auger lines. Their quantitative evaluation is possible, but more difficult in comparison to XPS. In some cases the chemical shift is too small for XPS, as e.g., for Cu metal and Cu(I)oxide. For these cases AES is an alternative. The AES lines are distinctly different in the case of these Cu-species although more complicated. For this example the amount and thickness of a thin anodic Cu_2O -layer on Cu metal has been successfully determined by the quantitative evaluation of the X-ray induced AES-signals in good agreement with electrochemical results [ii].

Refs.: [i] Castle JE (2006) *Auger electron spectroscopy*. In: Marcus P, Mansfeld F (eds) *Analytical methods in corrosion science and engineering*. Taylor and Francis, Boca Raton, pp 39–63; [ii] Speckmann HD, Haupt S, Strehblow HH (1988) *Surf Interf Anal* 11:148; [iii] Strehblow HH, Marcus P (2006) *X-ray photoelectron spectroscopy in corrosion research*. In: Marcus P, Mansfeld F (eds) *Analytical methods in corrosion science and engineering*. Taylor and Francis, Boca Raton, p 6

HHS

Scanning electron microscopy (SEM) and electron microprobe analysis (EMA) — A scanning focused electron beam causes the ionization of core levels similar to scanning AES. An alternative and thus a competing process to the ejection of Auger electrons is the emission of X-ray fluorescence radiation. These X-rays

are characteristic for the elements in a layer close to the specimen surface and thus are used for Electron Microprobe Analysis (EMA). The depth and width of the analyzed zone is ca. $2\ \mu\text{m}$ due to the larger escape depth of X-rays in comparison to electrons. This analytical method is used together with Scanning Electron Microscopy (SEM), which has a higher lateral resolution. SEM uses secondary electrons for imaging of the surface topography with very high lateral resolution. Secondary electrons may escape from the surface from a small excited area only due to their small mean free path of some nm which is a consequence of their small kinetic energy. Thus for SEM, scanning of the exciting and focused primary electron beam allows to analyze the surface topography. The emitted X-rays may be analyzed by an energy dispersive detector (EDAX) or by a wavelength dispersive detector working with a diffracting crystal. The analysis of electron-induced X-ray fluorescence is widely used to determine the distribution of elements at a surface with a lateral resolution in the μm range. EMA may be applied quantitatively with an appropriate calibration by standards. With calibration of the method as, e.g., by a thin layer AgCl standard formed by anodic oxidation of Ag in HCl solution, the thickness of a FeCl_2 layer has been deduced from EMA results. Similarly the accumulation of a FeSO_4 layer has been calculated as presented in [i].

Ref.: [i] Strehblow HH, Vetter KJ, Willgallis A (1974) *Ber Bunsen Ges Phys Chem* 75:824

HHS

Secondary ion mass spectroscopy (SIMS) —

When an ion beam as, e.g., Ar-ion hits a specimen surface in the vacuum, ions, charged clusters of atoms, molecules, and molecule fragments are emitted. They may be separated within a mass spectrometer according to their mass and charge and measured by a detector, usually a secondary electron multiplier (channeltron). Positive and negative ions may be detected according to positive and negative SIMS. SIMS is similar to usual mass spectrometry with the difference that cations and anions are knocked off from a solid surface by an ion beam. With the possible high mass resolution of mass spectroscopy one may separate isotopes of the same element even on species with almost the same mass like O_2^{18} and H^1Cl^{35} (mass defect). The high mass separation is important in this case to distinguish between oxygen evolution in O^{18} enriched water and HCl which may be present as a residue of the electrode preparation by cleaning in HCl-containing solutions. For mass separation usually quadrupole mass spectrometers or time-of-flight mass spectrometers (TOF-SIMS) are used. The

flight time of a sputtered species for a given distance depends on its velocity which changes with the mass for a given kinetic energy $E_{\text{kin}} = 1/2mv^2$ determined by the applied accelerating electric field. A chopped ion beam or a short pulse provides bunches of ions in the TOF mass spectrometer which arrive with different delay at the detector according to their velocity. Together with argon ion sputtering, elemental depth profiles of surface layers may be obtained [i, ii]. SIMS is a very sensitive method, however, it depends extremely on the surface condition, especially the electronic properties of the samples. Depending on the electronic condition of the surface (metal, semiconductor, or insulator) electronic exchange is more or less effective between the species leaving the surface and the specimen surface or a surface film (usually neutralization of the ions). This process affects seriously the SIMS efficiency which may change by orders of magnitude. Exchange of electrons is very effective for pure metal surfaces with a high density of electronic states. Ions are neutralized by uptake or release of electrons through tunnel processes during their transfer from the metal surface to the vacuum. After neutralization they are not deflected by electrostatic or magnetic fields and thus do not pass the energy analyzer and are lost for detection. Neutralization is much less effective for semiconducting or insulating surfaces due to the lack of electronic levels within the band gap which are accessible to electronic exchange with the sputtered species. Post-ionization of sputtered species by an electron beam or a glow discharge increase and stabilize the SIMS yield which is realized for commercial spectrometers. Similarly a small oxygen dose stabilizes the SIMS yield due to the formation of semiconducting or insulating surface oxides. SIMS has been used successfully for mechanistic studies, e.g., for anodic oxide formation with O^{18} tracers. Depending on the mobility of cations or anions within an oxide layer new oxide is formed at the outer surface or at the inner metal/oxide interface. SIMS depth profiles of further oxide grown in O^{18} -enriched water on a preformed layer may decide whether O^{18} -anions travel through the layer or not. This permits the decision whether oxygen anions or metal cations are more mobile within the oxide film and thus support ionic conduction under the influence of a high electric field within the layer during oxide growth.

Refs.: [i] Briggs D, Seah MP (1983) *Practical surface analysis*. Wiley, New York; [ii] McIntyre NS, Graham MJ (2006) *Studies on metal corrosion and oxidation phenomenon using secondary ion mass spectroscopy*. In: Marcus P, Mansfeld F (eds) *Analytical methods in corrosion science and engineering*. Taylor and Francis, Boca Raton, pp 65–102

Specimen transfer — The → kinetics of → electrode reactions depend seriously on the chemical composition and structure of electrode surfaces. → corrosion, i.e., the degradation of materials and its prevention by inhibitors or passive layers is one example of applied surface chemistry starting at their surface. Metal deposition, industrial electrochemical processes and reactions in → batteries, → accumulators, or in → fuel cells are others. The interpretation of these electrochemical and surface chemical processes and the determination of their mechanisms require the application of surface analytical tools. In situ methods work in the natural environment, whereas ex situ methods require the emersion of the samples or electrodes from the environment which goes along with the loss of potential control and contact to high gas pressures or electrolytes. The advantage of in situ methods is counterbalanced often by the disadvantage of less intense signals or less information. Usually one is interested in the undisturbed chemistry and structure of the electrode surfaces and surface layers. However, many methods providing rich information, work in the vacuum or ultrahigh vacuum (UHV) which requires a sample transfer from the environment into the vacuum of an analyzer chamber of the spectrometer. This transfer usually exposes the specimen to the laboratory atmosphere with possible changes by oxidation and oxide growth due to the access of oxygen and surface contaminations. These complications may be avoided by a specimen transfer within a closed system of UHV-chambers which allow the preparation of a specimen under the protection of purified argon with a subsequent transfer into the UHV without air access. Several systems have

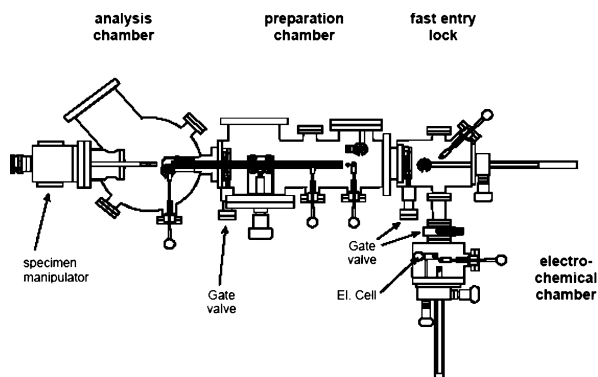

Surface analytical methods — Specimen transfer — Figure. Schematic diagram for an ESCA spectrometer with a specimen transfer within a closed system via a purified argon atmosphere between an electrochemical cell and the UHV with three chambers and an attached electrochemical chamber [v, vi]

been described and applied successfully, as e.g., a \rightarrow glove box or a specially designed electrochemical chamber attached to the spectrometer (see Figure) [i–vi]. Thus one may prevent the uncontrolled oxidation of an oxide layer as, e.g., Fe(II) to Fe(III) [vii] or the formation of oxide on reduced semimetallic metals like Cu or Ag [viii]. In the case of these metals one may even study the composition of the electrochemical double layer in dependence of potential and other parameters after emersion of an electrode from the electrolyte under potential control for hydrophobic conditions of their surface and its transfer via a purified argon atmosphere into the UHV of the spectrometer [viii–xiii]. In such a closed system one may start an electrochemical surface preparation with a sputter-cleaned surface with well-controlled surface composition and structure and may grow surface compounds under well-controlled electrochemical conditions with a free choice of the electrode potential and short oxidation or reduction times down to the ms-range, which allows even time-resolved measurements of reactions at electrode surfaces [vii, xiv].

Refs.: [i] Yeager E, O'Grady WE, Woo MYC, Aagans P (1978) *J Electrochem Soc* 125:348; [ii] Hubbard AT, Ishikama RM, Katekaru J (1978) *J Electroanal Chem* 86:274; [iii] Wagner FT, Ross PN (1983) *J Electrochem Soc* 130:1789; [iv] Olefford I, Elfstrom BO (1982) *Corrosion* 38:46; [v] Haupt S, Collisi U, Speckmann HD, Strehblow HH (1985) *J Electroanal Chem* 194:179; [vi] Haupt S, Calinski C, Hoppe HW, Speckmann HD, Strehblow HH (1986) *Surf Interface Anal* 9:357; [vii] Haupt S, Strehblow HH (1987) *Langmuir* 3:873; [viii] Lützenkirchen-Hecht D, Strehblow HH (1998) *Electrochim Acta* 43:2957; [ix] Kolb DM, Rath DL, Wille R, Hansen WN (1983) *Ber Bunsen Ges Phys Chem* 87:1108; [xii] Hansen WN, Kolb DM (1979) *J Electroanal Chem* 100:493; [xiii] Kolb DM (1987) *Z Phys Chem Neue Fol* 154:179; [xiv] Strehblow HH (2003) *Passivity of metals*. In: Alkire RC, Kolb DM (eds) *Advances in electrochemical science and engineering*. Wiley-VCH, Weinheim, pp 271–374

HHS

UV photoelectron spectroscopy (UPS) — For UV photoelectron spectroscopy (UPS), photoelectrons are ejected by the absorption of monochromatic UV light and their spectrum is taken in the same spectrometer as for XPS. The smaller energy of the He(I) (21.2 eV) or the He(II) (40.8 eV) resonance lines of discharge lamps allow the ejection from higher electronic levels only, including the valence band of solid specimens under study. UPS images the density of the electronic levels as a function of the energy. However, the spectrum depends not only on the electronic states where the photoelectrons come from, but also on the density of states of the accepting levels and further on secondary effects. UPS permits the determination of the band structure

and the work function of a metal or the threshold energy in the case of a semiconductor (energy of the upper valence band edge). Together with the determination of the band gap of a semiconductor (e.g., by measuring the photocurrent spectrum) one obtains a band model for the semiconductor surface [i]. Usually one assumes electronic equilibrium for a thin semiconductor film on a metal which allows conclusions on the energy of the Fermi level. Due to the small mean free path of 1 to 2 nm for the photoelectrons in the energy range of ca. 20 eV, UPS is also a surface-sensitive method.

Ref.: [i] Strehblow HH (2003) *Passivity of metals*. In: Alkire RC, Kolb DM (eds) *Advances in electrochemical science and engineering*. Wiley-VCH, Weinheim, pp 271–37

HHS

X-ray absorption spectroscopy, XAS — X-ray absorption spectra show oscillations at energies higher than the absorption edge, the so-called Extended X-ray Absorption Fine Structure (EXAFS). These oscillations of the relative absorption coefficient $\Delta\mu/\mu_0$ become visible for very intense and stable X-ray beams, which are available at synchrotron radiation sources. These oscillations are an interference phenomenon of the electrons leaving an absorber atom. When a core level electron is ejected from an absorber atom by the absorption of an X-ray photon it shows interference by reflection at the atoms of the surrounding coordination shells. The outgoing electron wave with the related DeBroglie wavelength $\lambda_{DB} = h/mv$ interferes with the wave reflected at these coordination shells. λ_{DB} depends on the velocity v of the electrons, their mass m , and thus on their kinetic energy $E = 1/2mv^2$ and thus the wavelength or energy of the absorbed X-ray photon $h\nu$. The relative variation of the absorption coefficient, the so-called EXAFS function $\chi(E) = \Delta\mu/\mu_0$ depends on λ_{DB} , the radius R_j of the coordination shells, their coordination numbers N_j , and their phase shift δ_j (Eq. 6). Equation (6) contains further the backscattering amplitude $f_j(k)$ and an attenuation factor for the electrons within the specimen with their mean free path $\lambda(E)$. The exponential Debye–Waller factor with the mean relative displacement σ_j takes care of the structural and thermal disorder of the coordination shell j of the specimen under study. The sine-function describes the interference of the outgoing and reflected wave at the shell j at distance R_j with the related phase shift δ_j . E_0 is the energy of the absorption edge and $E - E_0$ the excess energy of the absorbed X-ray photon which leads to the kinetic energy of the ejected electrons. Equation (6) sums the contributions of the various coordination shells j , which may be sepa-

rated by its Fourier transformation:

$$\chi(E) = \frac{\Delta\mu(E)}{\mu_0(E)} = \sum_j S_0^2 N_j \frac{|f_j(k)|}{kR_j^2} \sin[2kR_j + \delta_j(k)] \times \exp\left(-\frac{2R_j}{\lambda(k)}\right) \exp(\sigma_j^2 k^2) \quad (1)$$

$$k = \frac{\sqrt{2m(E - E_0)}}{\hbar}; \quad \lambda_{\text{DB}} = 2\pi/k.$$

The evaluation of the data yields R_j , N_j , and δ_j , i.e., the near-range order parameters of the material seen from the absorber atom. XAS permits the evaluation of the near-range order in the vicinity of the atoms of various elements of one specimen if the energies of their absorption edges are different enough and thus are well separated within the spectrum. It should be mentioned that XAS in reflection looks similar to XAS in transmission mode, however it is different and the evaluation of measurements requires the comparison with reflectivity data calculated from transmission EXAFS spectra. These evaluation procedures involving Kramers–Kronig transform are described in the literature [i–v].

XAS has been applied first to the bulk of specimens. However, the use of grazing incidence of an X-ray beam suppresses the contribution of the bulk substrate sufficiently and enhances that of surfaces and surface films. When the angle is smaller as its critical value of total reflection the contribution of the substrate is sufficiently suppressed so that one may study the structure of surfaces and thin films on electrode surfaces. For elements with high energy absorption edges, the energy of the incoming and reflected X-rays is sufficiently large to be transmitted through electrolytes with not too large losses of their intensity by absorption, so that in situ studies within the electrolyte become possible. The Figure depicts schematically an electrochemical cell which

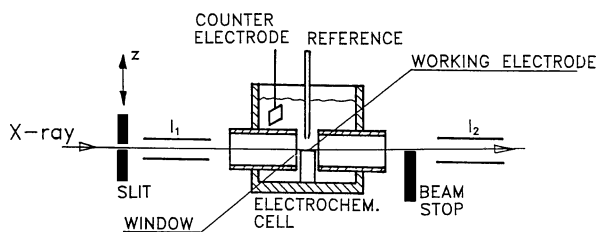

Surface analytical methods — X-ray absorption spectroscopy, XAS — **Figure.** Electrochemical cell for in situ XAS measurements in reflection, set up with a grazing incident X-ray beam, beam shaping slit, ionization chambers for the intensity measurement of incoming (I_1) and reflected beam (I_2) and beam stop for the direct nonreflected beam [vii]

has been applied for these studies with the geometry of total reflection for the incoming and reflected beam [v]. With this geometry the near-range order of passive films on a metal electrode has been studied in situ within the electrolyte under potential control. These measurements are less complicated for surface films on foreign substrates because of the missing contribution of the metal substrate to the EXAFS of the thin oxide layer. Passive films have been studied also on very thin metal films on membranes from the rear side while they have been oxidized almost completely at the electrolyte side.

A sufficient transparency of a thin electrolyte film is given for absorption edges starting with ca. 9 keV. Thus Cu has been examined successfully in situ within the electrolyte at its K-edge with $E_0 = 8.987$ keV. The situation is much better for Ag with $E_0 = 25.5$ keV. However, the angle of total reflection is extremely small in this case with $\alpha = 0.13^\circ$ in comparison to Cu with a larger value of $\alpha = 0.39^\circ$. This situation requires extremely flat and smooth surfaces. As XAS does not require a long-range order even amorphous materials or species dissolved within the electrolyte in front of an electrode may be investigated. Dissolution of Ag has been examined in front of a silver electrode by XAS in transmission [vi]. The evaluation of the EXAFS oscillations yields Ag^+ -ions with a coordination number of $N = 2.15$ radius $R = 0.23$ nm, and a mean relative displacement $\sigma = 0.0103$ for the first shell. This corresponds to $[\text{Ag}(\text{OH})_2]^{-1}$ ions with a somewhat larger Ag–O distance and σ value when compared to that of solid Ag_2O ($R = 0.196$ nm, $\sigma = 0.0077$ nm). EXAFS has been widely used for in situ studies of the structure of catalysts and its related changes during catalytic processes.

The exact energy and shape of the leading edge of XAS may be also used for qualitative determination of the oxidation state or binding situation of surface atoms. It changes similar to the chemical shift of XPS-signals and is known as Near Edge EXAFS (NEXAFS). Although NEXAFS may be applied in situ within the electrolyte, it is more difficult to distinguish several oxidation states of one element on one specimen due to the overlap of their chemical shifts. A special situation is given for the presence of Cr(VI) with a large chemical shift which causes a separate peak at smaller energies than the absorption edge of the Cr-metal substrate. In general, the evaluation of XPS-signals is easier compared to NEXAFS, but it requires UHV conditions and thus the emersion of the electrode from the electrolyte with the loss of potential control.

Refs.: [i] Strehblow HH (2003) Passivity of metals. In: Alkire RC, Kolb DM (eds) Advances in electrochemical science and engineering.

Wiley-VCH, Weinheim, pp 271–37; [ii] Borthen P, Strehblow HH (1995) *Physica B* 208–209:421; [iii] Borthen P, Strehblow HH (1995) *Phys Rev B* 52:3017; [iv] Borthen P, Strehblow HH (1995) *J Phys Condens Matter* 7:3779; [v] Lützenkirchen-Hecht D, Strehblow HH (2006) *Synchrotron methods for corrosion research*. In: Marcus P, Mansfeld F (eds) *Analytical methods in corrosion science and engineering*. Taylor and Francis, Boca Raton, pp 169–235; [vi] Lützenkirchen-Hecht D, Strehblow HH, Waligura CU (1998) *Corr Sci* 40:1037; [vii] Strehblow HH (2006) *Elektroden, Elektrodenprozesse und Elektrochemie*. In: Kleinermanns K (ed) *Gase, Nanosysteme, Flüssigkeiten*. Bergmann Schaefer, Lehrbuch der Experimentalphysik, vol. 5. De Gruyter, Berlin 557

HH S

X-ray photoelectron spectroscopy (XPS) —

Monochromatic X-rays from an X-ray source, usually the Mg $K\alpha$ - (1253.6 eV) or the Al $K\alpha$ -radiation (1486.6 eV), are absorbed at a specimen surface within the UHV chamber. When a surface atom absorbs an X-ray photon of energy $h\nu$, an electron is ejected from one of its core levels or higher electronic levels. These photoelectrons pass an electrostatic energy analyzer and are detected by a secondary electron amplifier, a so-called channeltron or an array of several channeltrons. The spectrum of the photoelectrons is taken by a linear increase of the retarding voltage at the entrance slit of the electrostatic energy analyzer. Thus one obtains the photoelectron spectrum with a peak for each electronic level of the absorbing elements at the sample surface. The relation between the binding energy E_B and the kinetic energy E_{kin} of the photoelectrons is given by Eq. (1). $e\Phi_A$ is the \rightarrow work function of the energy analyzer of the spectrometer. It is compensated usually by the spectrometer software. For solids, E_B is given relative to their \rightarrow Fermi level E_F , for gases relative to the vacuum level E_{vac} (ionization energy).

$$E_B = h\nu - E_{kin} - e\Phi_A . \quad (1)$$

With a calibration of the spectrometer one obtains a qualitative and quantitative elemental analysis of the surface composition [i]. The different charges, i.e., oxidation states of the elements and the varying binding situation yields small energy shifts of the XPS signals up to several eV. This chemical shift gives the information about the chemical situation of the elements. One may distinguish the different oxidation states of cations as, e.g., Fe metal, FeII and FeIII and anions, as e.g., oxides and hydroxides, etc. Thus, XPS provides many details about the chemistry of elements at the surface or within surface films. Thus, the binding energy E_B of the XPS signals gives information about the elements, the exact value of E_B about the binding situation and the relative peak area about the amount of the species be-

ing present at the surface or within a thin surface film. The attenuation of an XPS signal due to inelastic energy losses and the absorption of photoelectrons restricts the information of XPS to surface-near regions with a thickness of a few nm. This attenuation of the XPS signals due to the mean free path λ_e of the photoelectrons within a material allows the determination of the thickness of surface films. λ_e is in the range of 1 to 3 nm and thus one may measure surface film thicknesses of a monolayer up to 5 to 8 nm. λ_e changes with the kinetic energy according to Eq. (2). B is an empiric constant. Usually a value $B = 0.054 \text{ nm eV}^{-1/2}$ is taken for elements and $B = 0.096 \text{ nm eV}^{1/2}$ for inorganic compounds [ii, iii].

$$\lambda_e = B\sqrt{E_{kin}} . \quad (2)$$

Angular-resolved XPS-measurements use the relative attenuation of XPS-signals from the inner part of a layer with respect to those from the outer parts with increasing take off angle Θ given relative to the surface normal of the specimen. Equation (3) gives an example for the intensity of the metal signal I_{Me}^{Me} when the surface is covered by a thin oxide film of thickness d . As intensity ratios compensate for the sensitivity of the spectrometer and the special settings for the analyzer and the channeltrons they are preferred for quantitative results as given by Eq. (4). Both relations open the possibility to determine the thickness d of a surface layer. Equation (4) contains the atomic densities D of the related species ($Me = \text{metal}$, $ox = \text{oxide}$) which allows the evaluation of layers on alloys containing several metals and cations. Furthermore, ARXPS is a valuable tool to detect a possible depth distribution of elements or of oxidation states of one element or several different elements. An example is the inner enrichment of Fe^{2+} and the outer position of Fe^{3+} cations within a passive oxide layer on pure Fe formed in alkaline solution [iv, v]. Equation (5) gives the related dependence for the intensity ratio for the two iron species on Θ and the thicknesses d_1 of the inner Fe^{2+} -rich and d_2 of an outer Fe^{3+} -rich part.

$$I_{Me}^{Me} = I_{Me,max}^{Me} \exp(-d/\lambda_{ox} \cos \Theta) \quad (3)$$

$$\frac{I_{ox}^{Me}(\Theta)}{I_{Me}^{Me}(\Theta)} = \frac{D_{ox}^{Me}}{D_{Me}^{Me}} \left[\frac{1 - \exp(-d/\lambda_{ox}^{Me} \cos \Theta)}{\exp(-d/\lambda_{ox}^{Me} \cos \Theta)} \right] \quad (4)$$

$$\frac{I_{Fe^{3+}}}{I_{Fe^{2+}}} = \frac{D_{Fe^{3+}} \left[\exp\left(\frac{d_2}{\lambda_{ox} \cos \Theta}\right) - 1 \right]}{D_{Fe^{2+}} \left[1 - \exp\left(\frac{-d_1}{\lambda_{ox} \cos \Theta}\right) \right]} . \quad (5)$$

For passivation times $t_P > 1 \text{ s}$, Fe^{2+} is enriched inside the layer and Fe^{3+} is located at its surface [iv, v], as postu-

lated for thermodynamic reasons [vi]. At potentials positive to the Flade potential $E_{F1} = -0.23$ V for pH 13.7 the passive layer has the duplex structure as expected. However, for short-term oxidations after a few 100 ms, Fe^{3+} is still not present. First Fe^{2+} is formed and it takes ca. 1 s at $E = 0.16$ V in 1 M NaOH to oxidize Fe^{2+} to Fe^{3+} and to form the duplex structure of the layer, a process which is completed after ca. 100 s. This reaction becomes faster with increasing electrode potentials according to a larger driving force for this oxidation process [iv, v].

Refs.: [i] Strehblow HH, Marcus P (2006) *X-ray photoelectron spectroscopy in corrosion research*. In: Marcus P, Mansfeld F (eds) *Analytical methods in corrosion science and engineering*. Taylor and Francis, Boca Raton, pp 1–37; [ii] Seah MP, Dench WA (1979) *Surf Interface Anal* 1:2; [iii] Briggs D, Seah MP (1983) *Practical surface analysis*. Wiley, New York, p 187; [iv] Haupt S, Strehblow HH (1987) *Langmuir* 3:873; [v] Strehblow HH (2003) *Passivity of metals*. In: Alkire RC, Kolb DM (eds) *Advances in electrochemical science and engineering*. Wiley-VCH, Weinheim, pp 271–37; [vi] Vetter KJ (1967) *Electrochemical kinetics*. Academic Press, New York

HHS

S

Surface area → electrode surface area

Surface charge density → double layer, → Gibbs–Lippmann equation

Surface complexation — is complexation of metal ions by ligands immobilized on the electrode surface (→ electrode surface area). The ligands may be incorporated in the structure of a → carbon paste electrode, covalently bound to the surface of a chemically modified electrode (→ surface-modified electrodes), or adsorbed (→ adsorption) on the electrode surface etc. Surface complexation is not confined to electrodes. It can occur on many surfaces, e.g., minerals, when in contact with metal ion solutions or solutions containing complexing ions (in the first case, the surface provides the ligand and the solution the metal ion, whereas in the second case, the surface provides the metal ion and the solution the ligand). Surface complexation can be an important step in the dissolution of solid phases [ii].

Refs.: [i] Lovrić M (2002) *Stripping voltammetry*. In: Scholz F (ed) *Electroanalytical methods. Guide to experiments and applications*. Springer, Berlin, p 204; [ii] Blesa MA, Morando PJ, Regazzoni AE (1994) *Chemical dissolution of metal oxides*. CRC Press, Boca Raton

VM

Surface concentration — (Γ_i) is the amount (n_i) of substance i accumulated at the interface between two phases per unit interfacial area (A), defined as $\Gamma_i = \frac{n_i}{A}$. Most

frequently, surface concentration is expressed in units of mol cm^{-2} .

VM

Surface confined electrode reactions — see → surface redox reactions

Surface enhanced Raman scattering (SERS) — (also: Surface enhanced Raman spectroscopy (SERS)). Scattered light from electrochemical interfaces enhanced in its intensity by several orders of magnitude (up to 10^6 or more) is collected and analyzed in a monochromator. The obtained vibrational spectrum ranging from a few up to several thousand wavenumbers provides information about internal modes and orientation of molecular adsorbates, about the mode and strength of surface-adsorbate interaction, about structural details of adsorbate layers. Colored adsorbates and layers showing resonance Raman scattering can be studied, this approach being called surface enhanced resonance Raman scattering (SERRS).

Refs.: [i] Holze R (2008) *Surface and interface analysis: an electrochemists toolbox*. Springer, Berlin; [ii] Aroca R (2006) *Surface-enhanced vibrational spectroscopy*. Wiley, Chichester

RH

Surface energy → interfacial tension

Surface-modified electrodes — In order to alter the properties of an electron-conducting substrate, i.e., a → metal or → graphite or → semiconductor used as a part of an → electrode, different chemical compounds are produced/deposited/attached/immobilized on the surface. These electrodes are most frequently called surface-modified, chemically-modified, or → polymer-modified electrodes, depending on the methods and materials used for the modification. The obvious purpose of these efforts is the production of electrodes with novel and useful properties for special applications, but also to help gain a better understanding of the fundamental charge transfer processes at the interfaces. Usually the enhancement of the rate of the → electrode reaction (→ electrocatalysis) is the goal, however, the blocking of an unwanted reaction (e.g., → corrosion) is also possible. Molecular recognition, ion-sensitive and -selective properties can also be achieved, and such electrodes can also be used in electrochromatic display devices, → batteries, → supercapacitors or as photoelectrodes (→ photoelectrochemistry).

The surface layer can be formed by adsorption, chemisorption, chemical reaction (covalent bonding),

e.g., by using silanization, by \rightarrow *underpotential deposition*, or as organized monolayers by the Langmuir–Blodgett technique (\rightarrow *Langmuir–Blodgett films*, or as a \rightarrow *self-assembled monolayer*).

A monolayer or submonolayer is formed when chemisorption or chemical reaction occurs, or when a self-assembly method is applied, however, further layers can be developed on top of the primary layer. Usually multilayer films are formed when polymers are deposited on a conductor surface by \rightarrow *electropolymerization*, by solvent evaporation, or other methods. Further modification of a polymer film is also often used, e.g., by incorporation of enzymes.

Beside organic polymers, metalocyanates and other polynuclear compounds can also be deposited.

Heterogeneous and spatially defined layers and microstructures can also be prepared, e.g., bilayers from two different polymers, or multilayers by using layer by layer deposition of different constituents, deposition of polymers in porous template.

The essential feature of modified layers (other than blocking layers) is that they are capable of \rightarrow *charge transport* and they show redox properties.

In some cases the coating is electrochemically inactive, e.g., ion-exchange polymers like \rightarrow *Nafion* or zeolite and clay particles, however, redox species are often incorporated in these structures later on.

Refs.: [i] Murray RW (1992) In: Murray RW (ed) *Molecular design of electrode surfaces, techniques of chemistry series vol. 22*, Wiley, New York, pp 1–48; [ii] Salaita GN, Hubbard AT (1992) In: Murray RW (ed) *Molecular design of electrode surfaces, techniques of chemistry series vol. 22*, Wiley, New York, pp 49–118; [iii] Durst RA, Bäumer AJ, Murray RW, Buck RP, Andrieux CP (1997) *Pure Appl Chem* 69:1317

GI

Surface photothermal deflection \rightarrow *photothermal deflection spectroscopy*

Surface plasmon resonance (SPR) — Surface plasmon polaritons SPP (SPP are sometimes also called PSP plasmon surface polaritons) are electromagnetic waves (plasma oscillations; the transversal electromagnetic modes are either photon-like or similar to optical phonons, if their nature is a mix between these forms the modes are sometimes called polaritons) propagating along the metal/solution (or any other dielectric medium) interface. They can be generated by electromagnetic radiation (e.g., light in the visible range of the electromagnetic spectrum) coupling into oscillating modes of the electron density at this interface. SPPs are generated only with *p*-polarized light waves having their

electric field vector oriented parallel to the plane of incidence. Their propagation or wave vector lies in the plane of the metal surface. The field amplitudes associated with SPPR have a maximum at the interface and decay exponentially into both adjacent phases making their investigation an extremely surface-sensitive technique. Because of the electrooptical peculiarities SPPs cannot be caused by simple external reflection of a light beam at a smooth metal surface. Instead prism coupling is needed. SPPs have been used to enhance the surface sensitivity of various spectroscopic techniques like, e.g., \rightarrow *surface enhanced Raman scattering* and second harmonic generation (\rightarrow *spectroscopy*). The generation of SPPs at an interface causes a lower intensity of the reflected light beam. This intensity reaches a minimum at a typical angle of incidence. This angle is called surface plasmon resonance angle θ_{sp} . Because the shape of the reflectivity vs. angle of incidence curve depends sensibly on the electrooptical properties of the involved materials on both sides of the interface and can be calculated using Fresnel calculations, measurements of these curves provide a possibility to investigate the interface and any changes occurring therein by, e.g., adsorption on the metal surface etc. Applications of SPR range from studies of \rightarrow *adsorption* layers, kinetics of their formation, films of intrinsically \rightarrow *conducting polymers*, to numerous other interfacial phenomena.

Ref.: [i] Holze R (2008) *Surface and interface analysis: an electrochemists toolbox*. Springer, Berlin

RH

Surface potential \rightarrow *potential*, subentry \rightarrow *surface potential*

Surface pressure \rightarrow *interfacial tension*

Surface redox reactions — or surface \rightarrow *electrode reactions*, are reactions in which both components of the \rightarrow *redox couple* are immobilized on the electrode surface in a form of a \rightarrow *monolayer*. Immobilization can be achieved by means of irreversible \rightarrow *adsorption*, covalent bonding, self-assembling (\rightarrow *self-assembled monolayers*), adhesion, by Langmuir–Blodgett technique (\rightarrow *Langmuir–Blodgett films*), etc. [i]. In some cases, the electrode surface is the electroactive reactant as well as the product of the electrode reaction is immobilized on the electrode surface, e.g., oxidation of a gold, platinum, or aluminum electrode to form metal oxide. This type of electrode processes can be also considered as surface electrode reactions. Voltammetric response of a surface redox reaction differs markedly from that of a dissolved

redox couple. In \rightarrow *cyclic voltammetry*, the response consists of bell-shape peaks, instead of wave-shape voltammetric curves typical for processes controlled by semi-infinite \rightarrow *diffusion*. If the surface redox reaction is electrochemically reversible (\rightarrow *reversible redox reaction*), in the absence of lateral interactions between immobilized redox species, the cyclic voltammetric peaks are equal in height and fully symmetrical relative to the potential axes. If the surface redox reaction is quasireversible, the peaks are separated on the potential axes, and their \rightarrow *peak potential* difference can be exploited for extraction of the kinetic parameters [ii]. In parallel to cyclic voltammetry, \rightarrow *square-wave voltammetry* is the second-most powerful voltammetric technique to be applied for studying the kinetics of fast surface redox reactions [iii].

Refs.: [i] Bard AJ, Faulkner LR (2001) *Electrochemical methods. Fundamentals and applications*. 2nd edn. Wiley, New York; [ii] Laviron E (1982) *Voltammetric methods for the study of adsorbed species*. In: Bard AJ (ed) *Electroanalytical chemistry*, vol. 12. Marcel Dekker, New York, p 53; [iii] Lovrić M (2002) *Square-wave voltammetry*. In: Scholz F (ed) *Electroanalytical methods. Guide to experiments and applications*. Springer, Berlin, p 120

S

VM

Surface stress — The surface area A of a solid electrode can be varied in two ways: In a plastic deformation, such as cleavage, the number of surface atoms is changed, while in an elastic deformation, such as stretching, the number of surface atoms is constant. Therefore, the differential dU^s of the internal surface energy, at constant \rightarrow *entropy* and composition, is given by: $dU^s = \gamma dA_p + A \sum_{n,m} g_{nm} d\epsilon_{nm}$, where γ is the \rightarrow *interfacial tension*, dA_p is the change in area due to a plastic deformation, g_{nm} is the surface stress, and ϵ_{nm} the surface strain caused by an elastic deformation. Surface stress and strain are tensors, and the indices denote the directions of space. From this follows the generalized \rightarrow *Lippmann equation* for a solid electrode: $-\left(\frac{\partial \gamma}{\partial E}\right)_{T, \mu_i} = \sigma + (\gamma \delta_{nm} - g_{nm}) \left(\frac{\partial \epsilon_{nm}}{\partial E}\right)_{T, \mu_i}$, where σ is the surface charge density, E the \rightarrow *electrode potential*, and μ_i denotes the \rightarrow *chemical potential* of the species i in the solution; δ_{nm} is the Kronecker symbol. Precise measurements have shown that the last term is typically five to six orders of magnitude smaller than the first, and can usually be neglected [ii].

Refs.: [i] Lindford RG (1978) *Chem Rev* 41:81; [ii] Lipkowski J, Schmickler W, Kolb DM, Parsons R (1998) *J Electroanal Chem* 452:193

WS

Surface stress measurement — The understanding of the thermodynamics of solid/liquid interfaces is of im-

portance to all surface scientists and electrochemists. Despite the advent of surface-sensitive techniques, thermodynamic measurements remain a valuable tool for the investigation of surfaces and interfaces. During the past decades many attempts have been made to derive thermodynamic equations for the solid/liquid interface, and several methods were suggested for the measurement of changes in the \rightarrow *surface stress* (or the “specific surface energy”) of solid electrodes [i–v].

In most cases the variation in surface stress has been determined indirectly by measuring the potential dependence of the strain (i.e., electrode deformation) and then obtaining the variation in stress from the appropriate form of Hooke’s law (\rightarrow *bending beam* or *cantilever beam method*, *bending plate methods*: e.g., the measurement of the deformation of the electrode with the help of a \rightarrow *Kösters laser interferometer*).

Other methods proposed in the literature are, e.g., the piezoelectric method [vi–x], the extensometer method [xi–xii], and the meniscus-rise technique [i, xiii].

Refs.: [i] Morcos I (1978) *Specialist periodical reports electrochemistry*, vol. 6. In: Thirsk HR (ed) *The Chemical Society*. Burlington House, London, pp 65–97; [ii] Jaeckel L, Láng G, Heusler KE (1994) *Electrochim Acta* 39:1031; [iii] Ibach H, Bach CE, Giesen M, Grossmann A (1997) *Surf Sci* 375:107; [iv] Haiss W (2001) *Rep Prog Phys* 64:591; [v] Láng GG, Seo M, Heusler KE (2005) *J Solid State Electrochem* 9:347; [vi] Gokhshtein AY (1970) *Electrochim Acta* 15:219; [vii] Gokhshtein AY (1976) *Poverkhnostnoe natyazhenie tverdykh tel i adsorbtsiya (Surface tension of solids and adsorption)*. Nauka, Moscow; [viii] Malpas RE, Fredlein RA, Bard AJ (1979) *J Electroanal Chem* 98:171; [ix] Seo M, Ueno K (1996) *J Electrochem Soc* 143:899; [x] Ueno K, Seo M (1999) *J Electrochem Soc* 146:1496; [xi] Beck TR (1969) *J Phys Chem* 73:466; [xii] Lin KF, Beck TR (1976) *J Electrochem Soc* 123:1145; [xiii] Morcos I (1972) *J Phys Chem* 76:2750

GGL

Surface tension \rightarrow *interfacial tension*

Surface wave (in voltammetry) \rightarrow *cyclic voltammetry*

Surfactant \rightarrow *surface active substance*

Susceptance — In alternating current (AC) electrical \rightarrow *immittance* measurements, susceptance is the imaginary part of admittance given by:

$$Y = G + iB,$$

where Y is the admittance (which is the inverse of impedance ($Y = 1/Z$) measured in siemens [$S m^{-2}$], G the conductance [$S m^{-2}$], B the susceptance [$S m^{-2}$], and

i is the imaginary unit ($i = \sqrt{-1}$). When an electrical circuit is composed of passive elements (resistors, inductors, and capacitors) connected in parallel, the susceptance of the circuit is attributed to capacitors and inductors. In \rightarrow *electrochemical impedance spectroscopy*, an equivalent electrical circuit is often utilized to simulate the frequency dependence of a given electrodic process or electrical double-layer charging. In general, the susceptance is given by:

$$B = B_C - B_L,$$

where B_C is the capacitive susceptance and B_L is the inductive susceptance. For a parallel inductor || capacitor connection, the capacitive susceptance:

$$B_C = \omega C = 2\pi f C$$

is due to the capacitance C of the capacitor measured in [$F m^{-2}$], and the inductive susceptance:

$$B_L = 1/(\omega L) = 1/(2\pi f L),$$

is due to the inductance L of the inductor measured in henries [$H m^2$], ω is the angular frequency of the \rightarrow AC signal [rad/s^{-1}], and f is the frequency [Hz].

The nonzero susceptance of an equivalent electric circuit results in a phase shift ϕ , which is a difference in the phase of an AC current and AC voltage. The predominant capacitive behavior of a given circuit at a given frequency ω will cause a positive phase shift, where current leads voltage by the phase difference ϕ . The predominant inductive behavior of a circuit at a given frequency will cause a negative phase shift, where current lags voltage by a phase difference ϕ . The zero-phase condition is important in oscillatory circuits, where it is necessary to maintain oscillations, e.g., in \rightarrow *electrochemical quartz crystal nanobalance* circuits.

Refs.: [i] Macdonald JR (1987) *Impedance spectroscopy*. Wiley, New York; [iii] Hepel M, Cateforis E (2001) *Electrochim Acta* 46:3801

MHep

Suspension, electrochemistry of ~ — Solid particles, liquid droplets, \rightarrow *vesicles*, and biological cells suspended in solutions can cause faradaic and capacitive signals. Not only the size and the stability of the suspended particles but also surfactants determine the electrochemical response. Since colloidal suspensions are in meta-stable states, electrochemical behavior depends on the time-scale of the stability. Study on unstable suspension has been directed to aggregation and coalescence of particles, whereas that on stable suspension has to thermodynamics and kinetics as for huge molecules:

- a) **Unstable suspensions:** The electrochemical instability has been found in flexible particles such as droplets, liposomes and emulsions. Capacitive signals can be caused by the adhesion of droplets [i] or \rightarrow *liposomes* [ii] at the electrode surface. Redox species confined in liposomes burst into a solution after the redox reaction [iii]. The electrochemical oxidation of the ferrocene-dispersed aqueous emulsion causes coalescence of the oil droplets owing to a decrease in the surface tension [iv]. Electrochemical applications to emulsions have been used for evaluating partition coefficients in an oil phase [v], determining the high solubility of the monocation radical for tetrathiofulvalene [vi], and evaluating conductivity and viscosity of emulsions by the electric percolation [vii]. Applications of voltage to emulsions cause coalescence of water droplets [viii] and have been used for removal of water from petroleum [ix].
- b) **Stable suspensions:** Rigid dispersed particles often show an electrochemical behavior similar to conventional redox species. Micka [x] has performed a series of systematic studies on the behavior of particles suspended in electrolyte solutions. Most of the suspended compounds (insoluble salts and oxides) gave peak-shaped polarograms with a maximum at or near the \rightarrow *point of zero charge* (*pzc*) of the \rightarrow *mercury* electrode. Whereas Micka has explained the current peak at the point of zero charge by adsorption of the particles, Dausheva and Songina [xi] have discussed the stability of the electrolyte film at the electrode in dependence on the \rightarrow *electrode potential*. They have assumed that only around the *pzc* this film is fragile enough to allow impinging particles penetrating it and contacting the metal surface allowing electron transfer. The same authors have experimentally shown that mercury(I) iodide particles strongly adhere at a mercury electrode only in the vicinity of the *pzc* [xi]. When colloidal particles (\rightarrow *colloids*) contain redox sites, they give faradaic signals (\rightarrow *faradaic current*) that are due to iron oxide in ceramic colloids [xii], \rightarrow *polyaniline* [xiii], and \rightarrow *ferrocene* [xiv] in polymer microparticles, and metallic \rightarrow *nanoparticles* [xv].

See also the review [xvi].

Refs.: [i] Tsekov R, Kovač S, Žutić V (1999) *Langmuir* 15:5649; [ii] Hellberg D, Scholz F, Schubert F, Lovrić M, Omanović D, Agmo Hernández V, Thede R (2005) *J Phys Chem B* 109:14715; [iii] Zhan W, Bard AJ (2006) *Anal Chem* 78:726; [iv] Yoshida J, Chen J, Aoki K (2003) *J Elec-*

troanal Chem 553:117; [v] Texter J, Beverly T, Templar SR, Matsubara T (1987) *J Colloid Interf Sci* 120:389; [vi] Georges J, Desmetre S (1986) *Electrochim Acta* 31:1519; [vii] Georges J, Chen JW (1986) *Colloid Polym Sci* 264:896; [viii] Eow JS, Ghadiri M, Sharif AO, Williams TJ (2001) *Chem Eng J* 84:173; [ix] Eow JS, Ghadiri M (2002) *Chem Eng J* 85:357; [x] Micka K (1968) *Fresenius' Z Anal Chem* 234:119; [xi] Dausheva MR, Songina OA (1973) *Uspekhi Khim* 42:323; [xii] Heyrovský M, Jirkovský J, Štruplová-Bartáčeková M (1995) *Langmuir* 11:4309; [xiii] Aoki K, Chen J, Ke Q, Armes SP, Randall DP (2003) *Langmuir* 19:5511; [xiv] Xu C, Aoki K (2004) *Langmuir* 20:10194; [xv] Hernández-Santos D, González-García MB, García AC (2002) *Electroanalysis* 14:1225; [xvi] Rusling JF (1994) *Electrochemistry of micells, microemulsions, and related microheterogeneous fluids*. In: Bard AJ (ed) *Electroanalytical chemistry*, vol. 18. Marcel Dekker, New York

FS, KA

Sutton's accumulator — This was an → *accumulator* with a lead and a copper electrode in a copper sulfate electrolyte. Upon discharge copper ions are reduced to the metal and lead is oxidized to lead sulfate. These processes are reversed upon charging.

Ref.: [i] Hauck WP (1883) *Die Galvanischen Batterien, Accumulatoren und Thermosäulen*, 2nd edn. Hartleben's Verlag, Wien

FS

Svedberg, Theodor (The)



(© The Nobel Foundation)

(Aug. 30, 1884, Flerång, Sweden – Feb. 26, 1971, Klop-paberg, Sweden) Svedberg started to study chemistry in 1904 at Uppsala University, where he received his Ph.D in 1907 for studies on colloid systems. In 1908 he visited → *Zsigmondy*. Svedberg performed various studies on colloids, among these an experimental proof of the theory of Brownian movement developed by → *Einstein* and → *Smoluchowski*. He developed new techniques to produce colloidal dispersions, and he developed the so-called ultracentrifuge. The latter instrument allowed him to study proteins and other high-molecular-weight organic compounds. In 1926 he received the Nobel Prize in Chemistry. Svedberg also encouraged → *Tiselius* to

use the migration of colloidal particles in an electric field (→ *electrophoresis*) for their separation.

Ref.: [i] <http://nobelprize.org/index.html>

FS

Sweep rate → *potential sweep rate*

Swing cell → *rocking-chair batteries*

Swiss-roll cell — This cell was developed in Switzerland in 1982, and it is used on industrial-scale in case of the NiOOH electrode for the oxidation of primary alcohols to carboxylic acids, as, e.g., in vitamin C production. The electrolyte solution flows axially through the cell (see Figure), which is made up of rolled meshes of the nickel net anode and steel net cathode, separated from each other by polypropylene spacers, around the central current feeder rod.

The cell construction ensures a high electrode area per volume unit together with small electrode distances, which, even with poorly conductive electrolytes and/or at low current densities, results in good space-time yields. A high turbulence of the flowing electrolyte is due to the mesh structure and ensures high conversion rates.

Refs.: [i] Robertson PM, Berg P, Reimann H, Schleich K, Seiler P (1983) *J Electrochem Soc* 130:591; [ii] Steckhan E (1996) *Electroorganic synthesis*. In: Kissinger PT, Heineman WR (eds) *Laboratory techniques in analytical chemistry*, 2nd edn. Marcel Dekker, New York, pp 641–682; [iii] Jörissen J (2004) *Practical aspects of preparative scale electrolysis*.

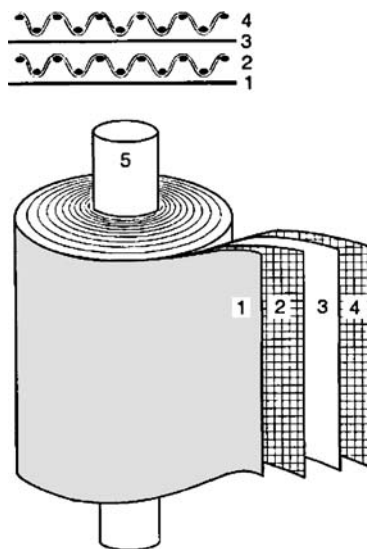

Swiss-roll cell — Figure. 1 = steel net cathode; 2 + 4 = polypropylene net; 3 = nickel net anode; 5 = current feeder

In: Bard AJ, Stratmann M, Schäfer HJ (eds) *Organic electrochemistry. Encyclopedia of electrochemistry*, vol. 8. Wiley-VCH, Weinheim, pp 29
MHer

SXM — A general abbreviation for → *scanning probe microscopy*, however, it is recommended to rather use *SPM*, due to the more descriptive nature of the latter expression ('P' for probe) [i].

Ref.: [i] Friedbacher G, Fuchs H (1999) *Pure Appl Chem* 71:1337

FG

Symmetry coefficient → *charge transfer coefficient*

Symmetry factor → *charge transfer coefficient*

Synchrotron techniques → *spectroscopy*

Synergistic adsorption — Coadsorption of two or more components under conditions (e.g., at concentrations) where neither of them adsorbs alone.

Refs.: [i] Wojciechowski K, Buffle J, Müller R (2005) *Colloids Surf A* 261:49; [ii] Montoux C, Williams CE, Meunier J, Anthony O, Bergeron V (2004) *Langmuir* 20:57

GH

Synproportionation → *conproportionation*

Synthetic metals → *conducting polymers*

Szebellédy, László — (Apr. 20, 1901, Budapest, Hungary (Austro-Hungarian Empire) – Jan. 23, 1944, Budapest, Hungary) Earned M.S. and Ph.D. degrees from the University of Budapest. He joined the staff of the same university and became a professor of inorganic and analytical chemistry in 1939. He also worked with Treadwell in Zürich and with Böttger in Leipzig.

Szebellédy with his co-worker, → *Somogyi* invented → *coulometric titration* (analysis) in 1938 [i]. He published also seminal papers on catalytic microreactions.

Ref.: [i] Szebellédy L, Somogyi Z (1938) *Fresenius Z Anal Chem* 112:313, 323, 385, 391, 395, 400

GI

Szily, Pál von



(May 16, 1878, Budapest, Hungary (Austro-Hungarian Empire) – Aug. 18, 1945, Magyaróvár, Hungary) He obtained his doctor of medicine degree at Budapest University in 1901. Szily initiated the colorimetric measurement of pH [i]. While working with Friedenthal H. in Berlin he proposed the application of artificial → *buffer* solutions by mixing monobasic and dibasic phosphates [ii–iv]. Despite his zeal for research and his acknowledged results [ii–vi], he had not become a professor in Hungary due to the discrimination of scientists of Jewish origin in the 1920s. Returning from Berlin he worked as a physician in different hospitals in Budapest, and from 1928 in Magyaróvár. He survived the concentration camp but died soon after.

Refs.: [i] Szily P (1903) *Physiolog Verhandl*, p 549; [ii] Friedenthal H (1904) *Z Elektrochem* 10:113; [iii] Sörensen SPL (1909) *Biochem Z* 21:131; [v] Dunsch L (1985) *Geschichte der Elektrochemie*. VEB Deutscher Verlag für Grundstoffindustrie, Leipzig, pp 100, 151; [vi] Szabadvary F (1964) *J Chem Educ* 41:105

GI

T

Tafel, Julius



(Courtesy of Dr. Klaus Müller)

(June 2, 1862, Choindez, Switzerland – Sep. 2, 1918, Munich, Germany) Tafel was an organic chemist (associated with Hermann Emil Fischer and Ludwig Knorr) and physical chemist (working with → Ostwald, F.W.) [i–iii]. He studied electrochemistry of organic compounds and the relation between rates of electrochemical reactions and applied → overpotentials [iv]. He is best remembered for the → Tafel equation, an empirically found relation connecting the current generated in an electrochemical system with the applied overpotential. Tafel introduced a hydrogen → coulometer to measure charges passing through electrochemical systems. Also, he demonstrated that hydrocarbons with isomerized structures can be generated upon electrochemical reduction of the respective acetoacetic esters (named Tafel rearrangement).

Refs.: [i] Müller K (1969) *J Res Inst Catal, Hokkaido Univ* 17:54; [ii] Bockris JO'M, Reddy AKN, Gamboa-Aldeco M (2000) *Modern electrochemistry, 2nd edn. Fundamentals of electroics, vol. 2A. Kluwer, New York, p 1106*; [iii] Emmert B (1918) *Ber Deut Chem Ges* 51:1686; [iv] Tafel J (1906) *Z Elektrochem* 12:112

EK

Tafel equation → Tafel observed an empirical relationship between the → overpotential and the → faradaic current:

$$\eta_{\text{ct}} = A + B \lg |j_{\text{ct}}| \quad (1)$$

This equation (Tafel equation) is of fundamental importance in studies of electrode kinetics. It is actually an approximation of the → Butler–Volmer equation at

sufficiently large overpotentials η . The Butler–Volmer equation (for details and meaning of symbols → Butler–Volmer equation) under conditions where there is no effect of concentration gradient

$$j_{\text{ct}} = j_0 \left\{ \exp \frac{\alpha n F}{RT} \eta_{\text{ct}} - \exp -\frac{(1-\alpha)nF}{RT} \eta_{\text{ct}} \right\} \quad (2)$$

can be simplified if one of the two exponential terms becomes sufficiently small; e.g., in case of an anodic process at large values of η ($\eta > \pm 25.7/n$ mV) the second term becomes negligible; in case of a cathodic processes at a sufficiently large value of η the first term vanishes. The corresponding simplified equations are in the first case

$$j_{\text{ct}} = j_0 \left\{ \exp \frac{\alpha n F}{RT} \eta_{\text{ct}} \right\} \quad (3)$$

and in the second case

$$j_{\text{ct}} = -j_0 \left\{ \exp -\frac{(1-\alpha)nF}{RT} \eta_{\text{ct}} \right\} \quad (4)$$

The dependence of the charge transfer overpotential η_{ct} on the charge transfer current density j_{ct} can be described in semilogarithmic form

$$\eta_{\text{ct}} = \frac{RT}{\alpha n F} 2.3 \log j_0 - \frac{RT}{\alpha n F} 2.3 \log |j_{\text{ct}}| \quad (5)$$

and

$$\eta_{\text{ct}} = \frac{RT}{(1-\alpha)nF} 2.3 \log j_0 - \frac{RT}{(1-\alpha)nF} 2.3 \log |j_{\text{ct}}| \quad (6)$$

This form is equivalent to the Tafel equation. It closely resembles the general type of an Eq. (1).

The term B is called **Tafel slope**. In case of a one-electron transfer process ($n = 1$) at $T = 25^\circ\text{C}$ and $\alpha = 0.5$ follows $B = \pm 118$ mV. Conveniently the Tafel equation is also displayed as

$$\lg |j_{\text{ct}}| = \lg j_0 + \frac{\alpha}{2.3RT} |\eta_{\text{ct}}|$$

and

$$\lg |j_{\text{ct}}| = \lg j_0 + \frac{(1-\alpha)}{2.3RT} |\eta_{\text{ct}}| \quad .$$

Refs.: [i] Tafel J (1900) *Z phys Chem* 34:187; [ii] Tafel J (1905) *Z phys Chem* 50:641; [iii] Inzelt G (2002) *Kinetics of electrochemical reactions. In: Scholz F (ed) Electroanalytical methods, Springer, Berlin, p 33*

RH

Tafel plot — Plot of $\log j$ versus E or η .

In case of a purely charge-transfer controlled current at the electrode one electrode process will dominate whereas the respective back-reaction contributes only a negligible fraction to the total current. Assuming this contribution to be <1% the back-reaction can be neglected at $\eta > \pm 118/n$ mV with slopes B depending on n and α . At smaller values of η deviations will appear:

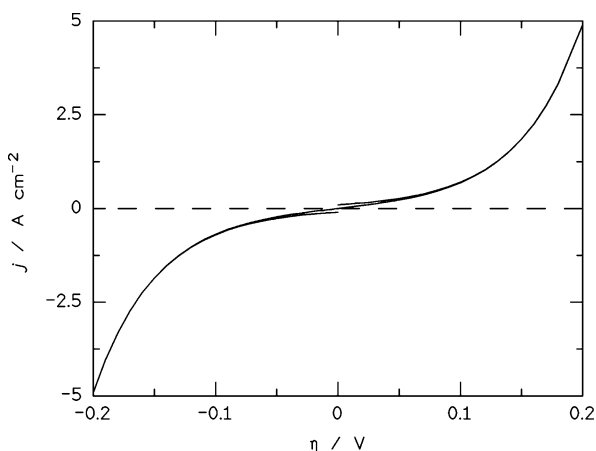

Tafel plot — **Figure 1.** Calculated charge transfer current density j as a function of \rightarrow overpotential η assuming a transfer coefficient $\alpha = 0.5$ and an \rightarrow exchange current density $j_0 = 0.1 \text{ A cm}^2$, and, in simplified form for the anodic and cathodic branch, respectively

The deviation caused by the simplifications in the \rightarrow Tafel equation becomes obvious only at small overpotentials. In a logarithmic display (Tafel plot) a different and more useful display results.

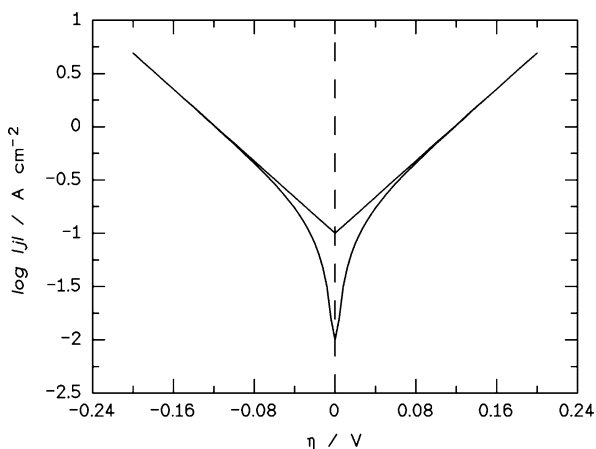

Tafel plot — **Figure 2.** Calculated logarithm of charge transfer current density j as a function of overpotential η assuming a transfer coefficient $\alpha = 0.5$ and an exchange current density $j_0 = 0.1 \text{ A cm}^2$, in simplified form for the anodic and cathodic branch, respectively

Because values of n are mostly 1, rarely 2, the slope of the Tafel plot yields the value of the charge transfer coefficient α , the intersection yields the \rightarrow exchange current density j_0 .

Ref.: [i] Tafel J (1905) Z phys Chem 50:641

RH

Tafel region — Part of the current density vs. \rightarrow electrode potential relationship which can be described in sufficiently good approximation with the \rightarrow Tafel equation. Part of the current density vs. electrode potential relationship which can be described in sufficiently good approximation with the \rightarrow Tafel equation.

RH

Tafel reaction \rightarrow hydrogen

Tafel slope \rightarrow Tafel equation

Taguchi sensor — The so-called Taguchi sensor (Tagushi sensor) is a \rightarrow conductimetric sensor that is used to detect reducing gases, such as combustible gases and volatile organic vapors in air. The Taguchi sensor is based on an n -type \rightarrow semiconductor (SnO_2), the electronic conductance of which increases dramatically in presence of reducing gases at an operating temperature of ca. 350°C . Taguchi sensors are frequently used in warning systems in both industrial and household applications.

Ref.: [i] Göpel W, Hesse J, Zemel JN (1991) Sensors – a comprehensive survey, vol. 2. VCH, Weinheim

JB

Tate's law \rightarrow drop weight method

Taube, Henry

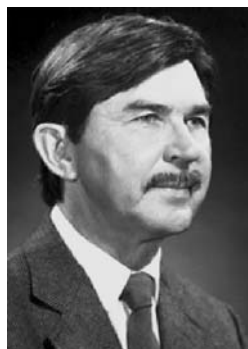

(© The Nobel Foundation)

(Nov. 30, 1915, Neudorf, Saskatchewan, Canada – Nov. 16, 2005, Paolo Alto, USA) Taube studied at the University of Saskatchewan, Saskatoon (B.S. 1935, M.S. 1937).

He obtained his Ph.D. degree at the University of California, Berkeley in 1940 where he spent two years as an instructor. He moved to Cornell University (1941–46), then he worked for the University of Chicago (1946–61) where he became professor. From 1962 he was professor of Stanford University. He received the 1983 Nobel Prize in Chemistry “for his work on the mechanism of \rightarrow electron transfer reactions, especially in metal complexes”.

Refs.: [i] <http://nobelprize.org/nobel-prizes/chemistry/laureates/1983/taube-cv.html>; [ii] Hargittai I (1997) Interview with Henry Taube. *Chemical Intelligencer*, October, pp 6–13; [iii] Ford PC, Solomon I (2006) *Angew Chem Int Ed* 45:692

TCNQ electrodes \rightarrow electrode, materials, subentry
 \rightarrow tetracyanoquinodimethane electrodes

Temkin, Mikhail (Menasii) Isaakovich

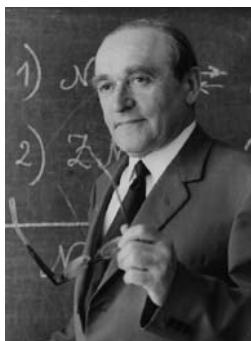

(Sep. 16, 1908, Belostok, Russia, now Białystok, Poland – Oct. 1, 1991, Moscow, Russia) After graduating from the Faculty of Chemistry, Moscow State University (1931) Temkin worked all his life in the Karpov Physico-Chemical Institute (1932–1991), where he headed the laboratory of chemical kinetics starting from 1938. His most known finding is the \rightarrow Temkin isotherm and corresponding theory of \rightarrow adsorption at uniformly inhomogeneous surfaces. Temkin’s primary scientific results are related to chemical kinetics and catalysis. He was the first who extended the transition-state approach to the kinetics of heterogeneous reactions at solid surfaces and applied this theory to interpretation of the kinetics of practically significant reactions (synthesis of ammonia, hydroxylamine, and methanol, conversion of methane and carbon monoxide, carbon gasification, ethylene and ammonia oxidation). In particular, the linear relationship of adsorption enthalpy and activation energy was confirmed for these important reactions (\rightarrow linear free energy relationships). The kinetic equation for ammonia synthesis reaction is often referred to as Temkin–

Pyzhov Equation. Temkin is also known for the theory of complex steady-state reactions. His model of the surface electronic gas related to the nature of adlayers presents one of the earliest attempts to go from physical chemistry to chemical physics. A number of these findings were introduced to electrochemistry, often in close cooperation with \rightarrow Frumkin. In particular, Temkin clarified a problem of the \rightarrow activation energy of the electrode process, and introduced the notions of ideal and real activation energies. His studies of gas ionization reactions on partly submerged electrodes are important for the theory of \rightarrow fuel cell processes. Temkin is also known for his activities in chemical \rightarrow thermodynamics. He proposed the technique to calculate the \rightarrow activities of the perfect solution components and worked out the approach to computing the \rightarrow equilibrium constants of chemical reactions (named Temkin–Swartsman method).

Ref.: [i] Shub FC, Kul’kova NV, Kuchaev VL, Murzin DYu (1992) *Zh Fiz Khim* 66:586

OP, GT

Temkin isotherm — This is a logarithmic relationship of the adsorbate surface coverage (θ) vs. \rightarrow partial pressure (\rightarrow fugacity) p in the gas phase or vs. its concentration c in solution bulk: $\theta = a + b \log p$ or $\theta = a + b \log c$ (a and b – phenomenological constants), derived by \rightarrow Temkin in 1941 [i] to describe the quasilinear dependence of the quantity of adsorbed \rightarrow hydrogen on the potential of a platinumized platinum electrode in acidic solutions [ii]. In the derivation, a so-called uniform surface inhomogeneity (equal probabilities to find the adsorption centers with different adsorption enthalpies q) has been assumed. To characterize the uniformly inhomogeneous surface, the inhomogeneity factor $f = (q_{\max} - q_{\min})/RT$ has been introduced (q_{\max} and q_{\min} are the highest and the lowest adsorption enthalpies, respectively). According to Temkin, the \rightarrow Langmuir isotherm is valid for any type of centers with one and the same q . Summation of these Langmuir isotherms in the region of mid-surface coverage ($0.2 < \theta < 0.8$) results in logarithmic relationships given above for relatively high inhomogeneity factors ($f > 4$). The logarithmic isotherm is valid for both non-dissociative and dissociative reversible adsorption. A finite number of different types of centers resulting from usual structural features of solid surfaces (edges, crystal planes, lattice defects, etc.) cause so-called biographic inhomogeneity, and the number of these naturally existing centers is sufficient for explaining the experimentally observed logarithmic isotherms. For instance, by summing only 4–5 Langmuir isotherms one

can already obtain an isotherm very close to the logarithmic. The biographic inhomogeneity can be discovered by differential radiotracer techniques. Typical manifestation of this phenomenon is the dependence of adsorption behavior on thermal treatment. Another physical reason for the Temkin isotherm is provided by the lattice gas model as well as by assuming lateral adsorbate-adsorbate repulsion [iii], even if the surface is structurally homogeneous. The latter situation can be considered as an adsorbate-induced inhomogeneity. The details can be found in [iv, v].

Refs.: [i] Temkin MI (1941) *Zh Fiz Khimii* 24:1312; [ii] Frumkin AN, Shlygin AI (1934) *Dokl AN SSSR* 2:176; *Izvestia AN SSSR Ser Khim* 773; [iii] Kobozev NI, Goldfeld YuM (1937) *Zh Fiz Khimii* 10:612; [iv] Gileadi E (1993) *Electrode kinetics*. VCH, New York, pp 266–273; [v] Bockris JOM, Khan SUM (1993) *Surface electrochemistry*. Plenum Press, New York, pp 199, 263

OP

Temperature coefficient (of electrochemical cells) — corresponds to the change of the → *electromotive force* as a function of the temperature in an electrode and it can be defined in two forms: isothermal temperature coefficient and a thermal temperature coefficient [i]. See also → *thermal temperature coefficient* and → *isothermal temperature coefficient*.

Ref.: [i] deBethune AJ, Licht TS, Swendeman N (1959) *J Electrochem Soc* 106:616

MBS

Temperature-pulse voltammetry → *heated electrodes*

Template synthesis — is the generic name for a diverse group of methods used to prepare nano-structured materials. Template synthesis typically involves the use of an inert solid phase of highly regular structure (such as a microporous membrane or a colloidal crystal) which is able to restrict the physical form of a reaction product [i]. Template methods are attractive because, in principle, they allow the size, shape, purity, and chirality of nanostructured materials to be controlled experimentally. In electrochemistry, template synthesis means the preparation of electrode materials and electrode surfaces using templates to direct the deposition and patterning [ii]. The goal of template-synthesis is to get micro- or nanostructures, e.g., for achieving → *microelectrode* behavior, or certain catalytic activities, or to study imprints of the template material to get information on the pore structure of the template [iii]. In these techniques the pores of micro- or nanoporous materials, e.g., → *membranes*, are used to synthesize the particles, or to deposit

material from solutions. Dissolution of the template material leaves the micro- or nanoparticles or structures on the electrode surface.

See also → *porous electrodes*.

Refs.: [i] Bartlett PN, Birkin PR, Ghanem MA (2000) *J Chem Soc Chem Commun* 1671; [ii] Martin CR, Mitchell DT (1999) *Template-synthesized nanomaterials in electrochemistry*. In: Bard AJ, Rubinstein I (eds) *Electroanalytical chemistry*, vol. 21. Marcel Dekker, New York; [iii] Hasse U, Scholz F (2006) *J Solid State Electrochem* 10:380

SF, FS

Tensammetry — Measurements of the interfacial capacitance (the differential → *double-layer capacity* C_{DL}) as a function of potential have been used widely, especially in the analysis of surface-active substances that are not electroactive. The method has been labeled tensammetry [i–iv]. Various experimental setups based on arrangements for AC → *polarography*, lock-in-amplifier, → *impedance* measurement, etc. have been employed. Since replacement of an adsorbed solvent molecule by an adsorbate molecule generally results in a change of the composition of the first layer of the electrolyte solution being in contact with the electrode, the different values of the dielectric properties of solvent and adsorbate molecules as well as their different size result in a change of the value of C_{DL} . Evaluation of the changes of C_{DL} as a function of the concentration of the adsorbate in the solution phase results in adsorption isotherms. Various isotherms (→ *Frumkin*, → *Langmuir*, etc.) have been used in the further evaluation [v]. Because of interferences of the kinetics of the → *adsorption* process in particular by slow transport and slow adsorption, tensammetry has been shown to provide unreliable results in some cases.

Refs.: [i] Breyer B, Hacopian S (1952) *Aust J Sci Res Ser A* 5:500; [ii] Doss KSG, Kalyanasundaram A (1951) *Current Sci* 20:199; [iii] Doss KS, Agarwal HP (1951) *Proc Ind Acad Sci* 34A:229; [iv] Breyer B, Bauer HH (1963) *Alternating current polarography and tensammetry*. Interscience, New York; [v] Damaskin BB, Petrii OA, Batrakov VV (1975) *Adsorption organischer Verbindungen an Elektroden*. Akademie-Verlag, Berlin, p 70; [vi] Jehring H (1974) *Elektrosorptionsanalyse mit der Wechselstrompolarographie*. Akademie-Verlag, Berlin

RH

Terquem–Callaud cell — This was a variant of the → *Daniell cell*. See also → *zinc*, → Zn^{2+}/Zn electrodes, → $Zn^{2+}/Zn(Hg)$ electrodes, → *zinc-air batteries (cell)*, and → *Leclanché cell*.

Ref.: [i] Hauck WP (1883) *Die Galvanischen Batterien, Accumulatoren und Thermosäulen*, 2nd edn. Hartleben's Verlag, Wien

FS

Tertiary current distribution — In \rightarrow *electroplating* processes this is current distribution across surface of electroplated object taking into account not only control by efficiency of mass transport and plating bath solution conductivity (primary current distribution) and kinetic effects of the electrode process (secondary current distribution), but also \rightarrow *polarization* effects caused by specific geometry of the electroplated object. Therefore concentration changes occurring at the working electrode surface affect the rate of the deposition and can be considered as an additional surface resistivity disturbing local \rightarrow *current density*.

Tesla, Nikola



(July 10, 1856, Smiljan, near Gospić, Lika, Austro-Hungarian Empire, now Croatia – Jan. 7, 1943, New York City, New York, USA) Fourth child of Rev. Milutin Tesla, a priest of the Serbian Orthodox Church, and Đuka Mandić. Primary education at the Gospić normal school (1862–66), the Gymnasium in Gospić (1866–70), and finally the Gimnazija Karlovac (1870–73). Studied physics and math at the Joanneum (Technische Hochschule) Graz (1875–77) but left without taking a degree. He also, briefly, attended the Karl-Ferdinand University in Prague (1880). After terminating his formal studies he had a severe nervous breakdown. His scientific career was rescued by a family friend, Ferenc Puskás (1848–1884) whose older brother Tivadar Puskás (1844–93) was Thomas Alva Edison’s European agent. Under their mentorship, Tesla became established as an electrical engineer, first in Budapest, then Paris, and finally New York (1884), where he worked briefly for Edison. After some initial struggles he formed his own company, Tesla Electric Co., in 1887. While in New York he met the famous industrialist George Westinghouse (1846–1914) who was in the throes of forming the Westinghouse Electric Company to distribute electric power (1886). For long-distance power transmis-

sion, it was becoming clear that high voltage and alternating current would probably be most efficient. However, such a system would not be safe without a transformer to decrease the voltage to an acceptable level at the receiving end of the line. Lucien Gaulard and John Dixon Gibbs had demonstrated a successful transformer in 1883 in London. Westinghouse therefore licensed the Gaulard–Gibbs transformers and, after some modifications, funded a successful demonstration of electrical lighting in Great Barrington, Massachusetts in 1886. But as far as industry was concerned, a key component was missing – a motor that would run efficiently on the AC power supply. Tesla provided the solution. In June 1888, George Westinghouse bought all of Tesla’s patents related to induction motors [i–iii]. Tesla’s induction motor was based on the principle that a magnetic field would rotate if two coils at right angles were supplied with AC currents that were 90 degrees out-of-phase. In one of those curious coincidences that abound in the history of science, the same principle had occurred to Galileo Ferraris (1847–1897) who disclosed the idea to the Turin Academy of Science on 18 March 1888 [ii]. However, he does not appear to have patented it. The resulting coupling of AC transmission with high efficiency electric motors would, within a few decades, revolutionize industrial production, and bring an end to the age of steam. With the profits from the Westinghouse deal, Tesla was able to expand his own electrical researches, and a remarkable period of activity followed. He patented the idea of the “Tesla coil” in March 1891 [v], and the first practical RF power supply in June 1891 [vi]. In that *annus mirabilis*, he also became an American Citizen. He then set about applying these devices to the solution of many technical problems, such as spark generation, power transmission, and even radio-controlled automata(!). Eventually, more than 100 patents would be granted in the US alone. A noteworthy excursion into chemistry occurred in 1896, when he patented an ozone generator [vii]. In 1900, he patented yet more circuits (in addition to the tesla coil) that helped make radio transmission a practical proposition [viii, ix]. Eventually, he also created man-made lightning flashes more than 10 meters long. But here the scientific part of the story ends. Sadly, his mental health deteriorated after 1900 and he became obsessed with the notion that the Earth could act as a giant conductor. His financial backers gradually withdrew, and by 1917 Tesla had fallen into bankruptcy. After a long mental decline he died alone in a New York City hotel room on 07 January 1943. He never married. In his honor, the SI unit of magnetic flux density is today called the *tesla* (symbol T).

Refs.: [i] US Patent 381968, *Electro-magnetic motor*, 01 May 1888; [ii] US Patent 381969, *Electro-magnetic motor*, 01 May 1888; [iii] US Patent 382279, *Electro-magnetic motor*, 01 May 1888; [iv] Ferraris G, *Rotazioni elettrodinamiche prodotte per mezzo di correnti alternate*. *Atti Accad Sci Torino* 23:360 (1887–88); [v] US Patent 447921, *Alternating electric current generator*, 10 March 1891; [vi] US Patent 454622, *System of electric lighting*, 23 June 1891; [vii] US Patent 568177, *Apparatus for producing ozone*, 22 September 1896; [viii] US Patent 645576, *System of transmission of electrical energy*, 20 March 1900; [ix] US Patent 649621, *Apparatus for transmission of electrical energy*, 15 May 1900

SF

Tetraalkylammonium salts — Tetraalkylammonium perchlorates (R_4NClO_4), especially tetraethylammonium perchlorate (Et_4NClO_4) and tetra-*n*-butylammonium perchlorate ($n\text{-Bu}_4NClO_4$) were traditionally used as \rightarrow supporting electrolytes in \rightarrow nonaqueous solutions [i]; however, they have the disadvantage that they may explode if they are heated or shocked [ii]. Tetraalkylammonium tetrafluoroborates (R_4NBF_4), tetraalkylammonium hexafluorophosphates (R_4NPF_6), and tetraalkylammonium trifluoromethanesulfonates ($R_4NCF_3SO_3$) are now more widely used. Solubilities, electrical resistivities, and potential windows of R_4NClO_4 , R_4NBF_4 , and $R_4NCF_3SO_3$ in several \rightarrow aprotic solvents are available in the literature [ii–v]. Where not commercially available, methods for preparing and purifying tetraalkylammonium salts for use as supporting electrolytes are likewise available [i–v]. With \rightarrow mercury electrodes, these ammonium salts may form Zintl-salts at very negative \rightarrow electrode potentials (see \rightarrow ammonium amalgam).

Refs.: [i] Mann CK (1969) *Nonaqueous solvents for electrochemical use*. In: Bard AJ (ed) *Electroanalytical chemistry*, vol. 3. Marcel Dekker, New York, pp 57–134; [ii] Izutsu K (2002) *Electrochemistry in nonaqueous solutions*. Wiley-VCH, Weinheim, chap 11; [iii] Sawyer DT, Sobkowiak A, Roberts JL Jr (1995) *Electrochemistry for chemists*. 2nd edn. Wiley, New York; [iv] House HO, Feng E, Peet NP (1971) *J Org Chem* 36:2371; [v] Rousseau K, Farrington GC, Dolphin D (1972) *J Org Chem* 37:3968

RJM

Tetracyanoquinodimethane electrodes \rightarrow electrode, materials, subentry \rightarrow tetracyanoquinodimethane electrodes

Tetrahydrofuran — A heterocyclic ether compound, also known as tetramethylene oxide, 1,4-epoxybutane, oxacyclopentane. This five-membered ring comprises four carbon atoms and one oxygen atom, is an aprotic polar \rightarrow solvent, and is fully miscible in other solvents such as water, alcohol, and ether. It also can be used as

a ligand in coordination complexes. THF is prepared by the reaction between formaldehyde and acetylene, which forms 2 butane-1,4 diol. After hydrogenation, 1,4-butane diol is formed and undergoes water elimination by acidic catalysis at about 100 °C to finally form THF. In order to obtain anhydrous THF (because of its possibility to form azeotrope with water, 5.3% wt., b.p. 62.3 °C), it can be distilled over a desiccant such as alkali hydroxide. THF is used as a solvent in polymerization processes, as a resin solvent for polymer coating, as well as a complexing solvent and a reaction solvent for several inorganic and organometallic compounds, alkali metals, alkali metal aluminum hydrides, and borohydrides.

THF is a moderately polar solvent (\rightarrow dielectric constant of 7.6 at 25 °C). It dissolves tetraalkyl ammonium salts (a few tenths of molar), Li salts such as $LiClO_4$, $LiAsF_6$, $LiBF_4$, and may form complex electrolyte solutions, $R_2Mg\text{-}BR_3$ and $R_2Mg\text{-}AlCl_3\text{-}nR_n$, at different acid–base ratios with Grignard reagents ($RMgX$, R = alkyl, aryl; X = halide). Its \rightarrow electrochemical window is around 4.2 V (cathodic limit close to 0 V vs. Li/Li^+). It was also suggested as a component in solutions for rechargeable \rightarrow lithium (metal) batteries and as a major solvent for rechargeable magnesium batteries. THF is known to react with strong oxidants, strong bases, strong acids (both protic and Lewis acids, undergoes polymerization), metal halides, and may form explosive peroxides due to reaction with oxygen traces.

Properties: vapor pressure: 26.3 kPa, M_w : 72.12 g mol⁻¹, viscosity: 0.46 kg m s⁻¹, density: 0.8892 g/ml (20 °C), dielectric const.: 7.6 (25 °C), M.P.: -108.5 °C, dipole moment: 1.75 D (25 °C), B.P.: 65.5 °C, surface tension: 26.4 dyn cm⁻¹ (25 °C), flash point: -14 °C, UV adsorption: 212 nm, ignition point: 230 °C, donor no.: 20.

Refs.: [i] Muller H (1995) *Tetrahydrofuran*. In: Elvers B, Hawkins S, Russey W (eds) *Ullmann's encyclopedia of industrial chemistry*, vol. A26. Wiley-VCH, Weinheim, pp 221–223; [ii] Aurbach D, Gofer Y (1999) *The electrochemical window of nonaqueous electrolyte solutions*. In: Aurbach D (ed) *Nonaqueous electrochemistry*. Marcel Dekker, New York, pp 199, 200; [iii] Mann CK (1970) *Nonaqueous solvents for electrochemical use*. In: Bard AJ (ed) *Electroanalytical chemistry*, vol. 3. Marcel Dekker, New York; [iv] Aurbach D, Moshkovich M (1998) *J Electrochem Soc* 145(8):2629

DA, NA

Tetraphenylborate — A large, weakly solvated anion of tetrahedral shape used in electrochemical measurements as the anion of the \rightarrow supporting electrolyte in nonaqueous solutions. Due to its weak \rightarrow solvation (see \rightarrow hydration and \rightarrow Born solvation energy) it is especially

useful in the comparison of electrochemical behavior of substances in various solvents. An appropriately large cation of the supporting electrolyte is needed too for this comparison.

MD

Tetrathiafulvalene electrodes → *electrode, materials, subentry* → *tetrathiafulvalene electrodes*

Thallium — Metal (atomic weight 204.383 g mol⁻¹) found in nature mostly associated with minerals of copper, zinc, lead, and iron. Industrial production is based on electrolytic reduction from solutions of thallium in sulfuric acid obtained by dissolution of dust and cementation residues generated during lead and zinc production.

RH

Thallium cation conductors → *solid electrolyte*

Thallium-conducting solid electrolyte → *solid electrolyte*

Tl⁺/Tl(Hg) electrode — A → *reference electrode* commonly known as Thalamid® electrode employing thallium amalgam (40 wt %) as electronically conducting phase and an aqueous solution of KCl (saturated or 3.5 M) saturated with TlCl. In comparison with the → *saturated calomel electrode* it shows a superior temperature stability up to $T = 135^\circ\text{C}$ without temperature hysteresis, no disproportionation of TlCl (as compared to Hg₂Cl₂) or significant complexation are found.

Ref.: [i] Baucke FGK (1974) *Chem Ing Techn* 46:71; [ii] Ives DJG, Janz GJ (1961) *Reference electrodes*. Academic Press, New York, p 258

RH

Theoretical capacity (of batteries) → *capacity*

Thermal battery → *reserve battery*

Thermal cell → *thermocell*

Thermal diffusion → *thermodiffusion, → Soret effect*

Thermal diffusion potential — Nonisothermal solutions develop an electric → *potential* gradient, $(\partial E/\partial x)$, but it is a not measurable quantity, because there is no method to determine electrical potential differences (ΔE) between two points at different temperatures, even for a uniform composition single phase. A similar situation appears when it is considered a potential difference between two points in phases which are chemically dif-

ferent in isothermal systems. Nonetheless, it is possible to establish a relationship between the potential gradient under some conditions and the heat transport of the ions and molecules present in the solution. Although such a relationship has no direct experimental application, it is of interest since it highlights the question where the → *electromotive force (emf)* arises for nonelectrolytic and nonisothermal solutions for a → *thermocell*. It requires to limit our attention to cases in which non-current flows through the electrolyte, for instance, a thermocell in open circuit. Any current flowing in such a system can only be transient and must provoke an increment of charged surfaces, that alters the electric field until reaching a value where the current flow becomes zero. For ordinary systems, the charge density to bring them around zero current are extremely small compared with the total concentration of positive or negative ions. The condition of zero current is thus established almost instantaneously. The potential difference between two points (ΔE) or the potential gradient $(\partial E/\partial x)$ which satisfies this condition is known as thermal diffusion potential [i].

In a solution with a cation 1 and an anion 2, one can considered two cases for which the thermal diffusion potential is defined. One case is at the initial state, when the concentration is uniform and a temperature gradient is established and a second case when the steady state is reached, in other words, when the migration of ions by the temperature gradient has ceased.

For the first case:

$$F \left(\frac{\partial E}{\partial x} \right)_{\text{in}} = - \left[\frac{t_1}{z_1} S_1^* + \frac{t_2}{z_2} S_2^* \right] \left(\frac{\partial T}{\partial x} \right)$$

and for the second case

$$F \left(\frac{\partial E}{\partial x} \right)_{\text{st}} = - \frac{(S_1^* - S_2^*)}{(z_1 - z_2)} \left(\frac{\partial T}{\partial x} \right).$$

Ref.: [i] Agar JN (1963) *Thermogalvanic cells*. In: Delahay P (ed) *Advances in electrochemistry and electrochemical engineering*, vol. 3. Interscience, New York, pp 31–121

MBS

Thermal electroanalysis — is an analytical method based on the measurement of temperature differences between the electrodes of an → *electrolysis* cell. The temperature differences between the → *anode* and the → *cathode* as well as the electrodes and the solution are measured. A relationship between the temperature differences and the electrolyte concentration can be established.

Ref.: [i] Holmes HF, Joncich MJ (1959) *Anal Chem* 31:28

MBS

Thermal liquid junction potential — This is the potential difference developed through a salt bridge of a \rightarrow *thermocell*. The potential difference corresponds to the thermal diffusion potential, which can be calculated by the entropy transport [i, ii]. Although only relative values instead of absolute values of this potential are thermodynamically accessible, there is evidence that indicates that for many aqueous electrolytes this value is less than $50 \mu\text{V K}^{-1}$. For strong acids or medium alkaline solutions this value is large. DeBethune et al. have suggested that these potential differences can be minimized using concentrated potassium chloride in the region of temperature gradients [i, ii].

Refs.: [i] deBethune AJ, Licht TS, Swendeman N (1959) *J Electrochem Soc* 106:616; [ii] deBethune AJ (1960) *J Electrochem Soc* 107:829

MBS

Thermal temperature coefficient — The temperature coefficient $\left(\frac{dE}{dT}\right)_{\text{th}}$ is the derivative of the electromotive force with respect to the temperature for the following thermocell.

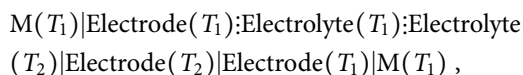

where T_1 is fixed and T_2 varies (see also \rightarrow *thermocell*). The thermal coefficient defined here is positive when the hot terminal electrode of the cell is the positive electrode [i].

Isothermal coefficient and thermal coefficient are related by the following expression, where the second term is the isothermal coefficient of the half reference cell.

$$\left(\frac{dE}{dT}\right)_{\text{th}} - \left(\frac{dE}{dT}\right)_{\text{isoth,ref}} = \left(\frac{dE}{dT}\right)_{\text{isoth}}.$$

See also \rightarrow *isothermal temperature coefficient* and \rightarrow *temperature coefficient*.

Ref.: [i] deBethune AJ, Licht TS, Swendeman N (1959) *J Electrochem Soc* 106:616

MBS

Thermocell (thermogalvanic cell) — is a cell that comprises a reference \rightarrow *half-cell* maintained at constant temperature, and another half-cell under study whose temperature is varied in a controlled manner [i, ii]. The variation of the temperature for the half-cell under study allows determining the \rightarrow *temperature coefficient*. However, temperature differences between both half-cells may induce other undesired additional effects to the electrochemical reaction. The following figure shows a schematic diagram of a commonly used thermocell.

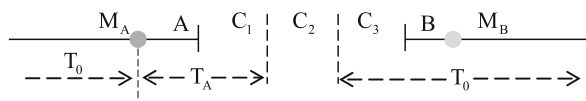

Thermocell (thermogalvanic cell) — Figure

In that diagram A and B represent both electrodes. C_1 is the concentration of the electrolyte 1 in contact with the electrode A. C_2 is the salt bridge electrolyte concentration. C_3 is the concentration of the electrolyte 3 in contact with the electrode B. The electrodes are joined through metallic conductors M_A and M_B connected to a \rightarrow *potentiostat*. The cell under study A- C_1 is kept at a temperature T_A and the reference half-cell B- C_3 is maintained at a temperature T_0 . For the determination of the temperature coefficient, the temperature in the half-cell A- C_1 is varied, while the temperature T_0 is kept constant.

The undesirable additional potential differences produced by the temperature differences between both half-cells are the following: The potential difference established by the temperature gradient in the conductor M_A , this component is described by the \rightarrow *Thomson effect*, and the potential difference that is produced in the salt bridge that can be described by thermodiffusion (\rightarrow *Soret effect*).

Refs.: [i] Agar JN (1963) *Thermogalvanic cells*. In: Delahay P (ed) *Advances in electrochemistry and electrochemical engineering*, vol. 3. Interscience, New York, pp 31-121; [ii] Bárcena Soto M (2000) Ph.D. thesis, Humboldt Universität zu Berlin; [iii] Newman J, Thomas-Alyea KE (2004) *Electrochemical systems*, 3rd edn. Wiley Interscience, Hoboken, pp 326

MBS

Thermodiffusion \rightarrow *Soret effect*

Thermodynamics — deals with the interrelations between \rightarrow *energy* and matter and the laws that govern them. The energetic changes in a system are governed by the fundamental laws of thermodynamics, which have been deduced directly from experience. The first law of thermodynamics simply states the principle of conservation of energy. The second law of thermodynamics states whether or not a process takes place in one or the other direction. For instance, heat always spontaneously flows from a higher temperature body to another one with lower temperature and never in the opposite direction. The second law of thermodynamics provides the definition of \rightarrow *entropy*. The third law of thermodynamics, also known as \rightarrow *Nernst's theorem*, states the possibility

to determine absolute entropies. For the description of the state (\rightarrow *equilibrium*) and changes (\rightarrow *reversibility*) of a thermodynamical system the state functions (e.g., \rightarrow *internal energy*, \rightarrow *enthalpy*, \rightarrow *Gibbs energy*) are used, the changes of which depend only on the initial and final states of the system, i.e., they do not depend on the trajectories followed. The state functions depend on the state variables, e.g., pressure, temperature, volume, and the amount and matter.

The relationship between the molar \rightarrow *Gibbs energy* change (ΔG) of \rightarrow *cell reaction* and the \rightarrow *potential of the cell reaction* (E_{cell}) is given under the entry \rightarrow *galvanic cell*.

Statistical thermodynamics takes into account the microscopic structure of matter and how it is constituted. According to \rightarrow *Boltzmann* the entropy can be correlated with the microscopic disorder of the system. Beside the Boltzmann distribution formula (\rightarrow *Debye–Hückel equation*) other statistics (e.g., \rightarrow *Fermi–Dirac statistics*) are of importance in electrochemistry (\rightarrow *semiconductors*, \rightarrow *BCS theory*).

The thermodynamics of irreversible processes is important in electrochemistry for \rightarrow *transport phenomena* (\rightarrow *mass transport*, \rightarrow *Onsager*, \rightarrow *Onsager reciprocal relations*, \rightarrow *Wagner equation*) and the formation of dissipative structures (\rightarrow *electrochemical oscillations*, \rightarrow *Prigogine*, \rightarrow *Liesegang*). Transport processes in electrochemistry often involve coupled fluxes, e.g., \rightarrow *diffusion* and \rightarrow *migration*, i.e., coupled mass and charge transport related to the driving forces' concentration and potential gradient.

Refs.: [i] Guggenheim EA (1993) *Thermodynamics*. North Holland Elsevier, Amsterdam; [ii] Klotz IM, Rosenberg RM (1994) *Chemical Thermodynamics*. Wiley Interscience, New York; [iii] Atkins PW (1995) *Physical chemistry*. Oxford University Press, Oxford; [iv] Lange E, Göhr H (1962) *Thermodynamische Elektrochemie*. Hüthig, Heidelberg

Thermodynamic temperature, T — Base quantity in the system of quantities upon which SI is based [i–iii].

A temperature of 0 K is called “absolute zero”. It coincides with the minimum molecular activity, i.e., thermal energy of matter. The thermodynamic temperature was formerly called “absolute temperature”. In practice, the International Temperature Scale of 1990 (ITS-90) [i] serves as the basis for high-accuracy temperature measurements. Up to 700 K, the most accurate measurements of thermodynamic temperature are the NBS/NIST results for Constant Volume Gas Thermometry (CVGT). Above 700 K, spectral radiometry is used to measure the ratio of radiances from a reference

blackbody and from a blackbody at unknown thermodynamic temperature.

The idea of a thermodynamic temperature scale was first proposed in 1854 by the Scottish physicist William Thomson, Lord Kelvin [iv]. He realized that temperature could be defined **independently of the physical properties of any specific substance**. Thus, for a substance at thermal equilibrium (which can always be modeled as a system of harmonic oscillators) the thermodynamic temperature could be defined as the average energy per harmonic oscillator divided by the \rightarrow *Boltzmann constant*. Today, the unit of thermodynamic temperature is called kelvin (K), and is defined as the fraction 1/273.16 of the thermodynamic temperature of the triple point of water.

Refs.: [i] Preston-Thomas H (1990) *Metrologia* 27:3, errata *Metrologia* 27:107; [ii] Quinn TJ (1990) *Temperature*. Academic Press, New York; [iii] Cohen ER, Cvitas T, Frey JG et al. (eds) (2007) *IUPAC quantities, units and symbols*. In: *Physical chemistry, 3rd edn*, RSC Publishing, Cambridge, UK, pp 4, 85–87; [iv] Lord Kelvin (William Thomson) (1848) *Philos Mag* 33:313; Reprinted in: *Sir William Thomson (1882) Mathematical and physical papers*, vol. 1. Cambridge University Press, Cambridge, pp 100–106

FS, SF

T

Thermogalvanic cell \rightarrow *thermocell*

Thermoneutral potential — (Thermoneutral voltage) The voltage E given by

$$E = \frac{\pm \Delta H^0}{nF}$$

with cell voltage E , enthalpy of cell reaction ΔH^0 , number of electrons transferred in \rightarrow *cell reaction* n , for an electrochemical reaction (\pm depending on the type of electrochemical reaction: + in case of an electrolysis, – in case of a galvanic cell). For the \rightarrow *electrolysis* reaction

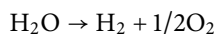

$\Delta G^0 = 228 \text{ kJ mol}^{-1}$; $\Delta H^0 = 242 \text{ kJ mol}^{-1}$; $\Delta S^0 = 188 \text{ J mol}^{-1} \text{ K}$ at $T = 298 \text{ K}$ and thus $E = 1.25 \text{ V}$ with water vapor as reactant.

The figure shows a plot of cell voltage (lower line) and thermoneutral voltage (upper line) for the water electrolysis reaction assuming water vapor as reactant.

In region I no electrolysis is possible at voltages below the lower line. In region II electrolysis is possible if a voltage above the line is provided and the necessary heat is supplied from the environment. At voltages above the upper line (region III) electrolysis proceeds with additional generation of heat.

GI

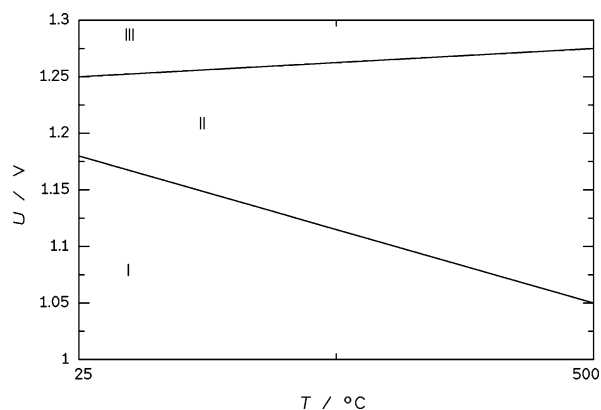

Thermonutral potential — Figure

Refs.: [i] Tilak BV, Lu PW, Colman JE, Srinivasan S (1981) *Electrolytic production of hydrogen*. In: Bockris JO'M, Conway BE, Yeager E, White RE (eds) *Comprehensive treatise of electrochemistry*, vol. 2. Plenum Press, New York, p 15

RH

Thin-film electrode — An \rightarrow electrode covered with a thin film of a given substance. The purpose of placing a thin film on the electrode surface is to obtain desired electrode properties. Many different substances have been used to prepare film electrodes; they include among others: mercury (see \rightarrow thin mercury film electrodes) gold, boron-doped diamond (see \rightarrow boron-doped diamond electrode), conductive polymers (see \rightarrow polymer-modified electrode), and alkanethiols. The film thickness can vary from several micrometers (mercury) to monomolecular layers (thiols). In some cases (e.g., for \rightarrow spectroelectrochemistry purposes) very thin layers of either gold or tin oxide are vapor-deposited onto glass plates. Thin film electrodes are often called \rightarrow surface-modified electrodes.

Refs.: [i] Fujihira M, Rubinstein I, Rusling JF (eds) (2007) *Modified electrodes*, vol 10. In: Bard AJ, Stratmann M (eds) *Encyclopedia of electrochemistry*. Wiley-VCH, Weinheim; [ii] Tucceri R (2004) *Surf Sci Rep* 56:85

ZS

Thin layer — A layer of \rightarrow electrolyte solution (molten salt electrolyte, \rightarrow ionic liquid) of about 2 to 100 μm thickness is commonly treated as a thin layer because of particular properties and behavior. In bulk \rightarrow electrolysis methods the amount of convertible species contained in a thin layer is very limited, thus exhaustive electrolysis becomes feasible. In numerous spectroelectrochemical setups the electrolyte solution confined between the electrode surface under investigation and the

cell window (of whatever material) form a thin layer with the typical properties mentioned. They may in turn influence the results of the spectroscopic investigation caused by, e.g., insufficient supply of reactants during an extended spectroscopic experiment.

Thin layer concepts may also be involved in metal deposition into thin films of mercury during stripping analysis, in (electro)chemical processes in adsorbates, films or precipitates on modified electrodes, or in \rightarrow scanning electrochemical microscopy.

Ref.: [i] Bard AJ, Faulkner LR (2001) *Electrochemical methods*, 2nd edn. Wiley, New York

RH

Thin layer activation \rightarrow radiochemical (nuclear) methods in electrochemistry

Thin-layer cell — An electrochemical cell with the reactant solution confined to a \rightarrow thin layer. \rightarrow mass transport can be neglected as long as the layer thickness l is smaller than the diffusion layer thickness $l \ll (2Dt)^{1/2}$ for a given experimental time t . Thin-layer cells are frequently employed in spectroelectrochemical experiments and in \rightarrow cyclic voltammetry.

Refs.: [i] Hubbard AT (1973) *CRC Crit Rev Anal Chem* 2:201; [ii] Bard AJ, Faulkner LR (2001) *Electrochemical methods*, 2nd edn. Wiley, New York

RH

Thin mercury film electrode — An \rightarrow electrode that is prepared by placing a thin layer of \rightarrow mercury on a noble, conducting substrate. Smooth mercury films can be obtained on metal surfaces (Ag, Au, Ir, Pt, Cu), most easily on Ag and Au, however, then the films are rather metal \rightarrow amalgams. The \rightarrow carbon substrates (graphite, glassy carbon) are not 'wettable' by mercury and therefore mercury films are in fact built of many small mercury droplets. Mercury film electrodes found their main application in \rightarrow stripping analysis (cathodic and anodic) and particularly in the determination of ultra-traces of metals. They are also used under conditions of high negative potentials and strong convection where the \rightarrow hanging mercury drop is unstable.

Ref.: [i] Brainina Kh, Neyman E (1993) *Electroanalytical stripping methods (Chemical analysis: a series of monographs on analytical chemistry and its applications)*. Wiley Interscience, New York

ZS

Thomas-Fermi theory — This is an early version of density functional theory, which accounts for the kinetic energy of the electrons and for Coulomb interactions, but neglects exchange and correlations. It

was introduced into → *double layer* theory for metal electrodes by O.K. Rice, and later revived by Kornyshev et al.; however, it is too simple even for qualitative considerations, since it predicts work functions and interfacial capacities which are essentially independent of the nature of the metal.

Refs.: [i] Rice OK (1928) *Phys Rev* 31:105; [ii] Kornyshev A, Schmickler W, Vorotyntsev M (1982) *Phys Rev B* 25:5244; [iii] Lundquist S, March NH (ed) (1983) *Theory of the inhomogeneous electron gas*. Plenum Press, New York

WS

Thomson, William → *Kelvin*

Thomson (William Th.) pile — This was an assembly of → *Daniell cells*. See also → *zinc*, → *Zn²⁺/Zn electrodes*, → *Zn²⁺/Zn(Hg) electrodes*, → *zinc-air batteries (cell)*, and → *Leclanché cell*.

Ref.: [i] Hauck WP (1883) *Die Galvanischen Batterien, Accumulatoren und Thermosäulen*, 2nd edn. Hartleben's Verlag, Wien

FS

Thomson effect → *Thomson heat*

Thomson coefficient τ — is the → *Thomson heat* (Q_{th}) of the transport of one mole of charged particles in an homogeneous phase from a high temperature site to another one at lower temperature with a temperature difference of one degree [i]. The unit of the Thomson coefficient is VK^{-1} . The relationship of Q_{th} and τ is given by the following expression:

$$Q_{\text{th}} = z_i \tau,$$

where z_i is the charge of the particle. For the case of an electron, $Q_{\text{th}} = \tau$. The Thomson coefficient relates the entropy transported ($S^\#$) with the temperature difference between cold and hot places and the absolute temperature by the following expression:

$$\tau = T \left(\frac{\partial S^\#}{\partial T} \right)_p.$$

Refs.: [i] Lange E, Göhr H (1962) *Thermodynamische Elektrochemie*. Hüthig, Heidelberg; [ii] Mills I, Cvitas T, Homann K, Kallay N, Kuchitsu K (1993) *IUPAC quantities, units and symbols in physical chemistry*, 2nd edn. Blackwell Scientific Publications, Oxford, p 37

MBS

Thomson heat — corresponds to the heat produced by the transport of a charged particle in an electric conductor through a temperature gradient in steady state. Particles in an homogeneous phase are transported from

a site at high temperature to another one at lower temperature and the entropy can be calculated in terms of Thomson effect [i]. See also → *Thomson coefficient*.

Ref.: [i] Lange E, Göhr H (1962) *Thermodynamische Elektrochemie*. Hüthig, Heidelberg

MBS

Three-dimensional electrode — This term is used for electrodes in which the electrode–solution interface is expanded in a three-dimensional way, i.e., the → *electrode* possesses a significantly increased surface area due to nonplanarity, so that it can be housed in a smaller volume. This can be achieved by constructing corrugated electrodes, reticulated electrodes, → *packed bed electrodes* (see also → *column electrodes*), → *carbon felt electrodes*, or → *fluidized bed electrodes*. Three-dimensional electrodes are important for achieving high conversion rates in electrochemical reactions. Therefore they are especially important in technical electrochemistry, wastewater cleaning, and flow-through analytical techniques, e.g., → *coulometry* in flow systems. However, the → *IR-drop* within three-dimensional electrodes is an inherent problem.

Ref.: [i] Wendt H, Kreysa G (1999) *Electrochemical engineering, science and technology in chemical and other industries*. Springer, Berlin

FS

Three-electrode system — A measurement system with a → *potentiostat* that uses three electrodes: → *working*, → *counter*, and → *reference*. The systems work in such a way that a desired potential is imposed to the working electrode vs. the reference electrode. The current in the cell flows only between the working and counter electrodes. The reference electrode is not loaded with the current, therefore it preserves its potential even under conditions of high current flowing in the cell. The application of the three-electrode system allows also the elimination of → *salt-bridge* resistance and consequently the ohmic potential drop which influences the recorded → *voltammograms*. Three-electrode systems do not compensate the entire resistance in the cell. See also → *electrochemical cell*, → *IR_u potential drop*.

Ref.: [i] Bard AJ, Faulkner LR (2001) *Electrochemical methods*, 2nd edn. Wiley, New York

ZS

Three-halves law → *Schottky*

Three-phase boundary — Whereas two phases can share one common interface, three adjacent phases can only share one common line (Fig. 1). This line is called

three-phase boundary line, three-phase junction, or three-phase interline. Three-phase boundaries are of importance whenever an electrode is constituted of more than two phases. This is very frequently the case, e.g., in → *batteries*, → *surface-modified electrodes*, → *paste electrodes*, electrodes used for → *voltammetry of immobilized particles* and droplets [i], etc. Three-phase boundaries play an exceptional role in systems where electron and ion-transfer reactions are coupled in the three-phase system in such a way that the electron exchange occurs between two of the phases, whereas the ion transfer occurs between one of these two phases and the third phase [i–ii]. Since the three-phase boundary is a line, the currents exchanged via such junctions will be generally very small and only for extended lengths they may reach significant values [iii]. In many cases of → *three-phase electrodes*, the reaction starts at the three-phase boundary and transforms to a mechanism where the electron transfer occurs across one interface and the ion transfer across the other interface (the two interfaces that meet at the three-phase boundary). With reference to the Figure, an example of an electrochemical reaction at a three-phase boundary is a system consisting of graphite (phase 1), Prussian blue (phase 2), and an aqueous electrolyte solution (phase 3). Electrons will be exchanged between graphite (phase 1) and Prussian blue (phase 2), whereas cations, e.g., K^+ , are exchanged between Prussian blue (phase 2) and the electrolyte solution (phase 3). Such reactions may start at the three-phase boundary (for proof see [iv]) and can further proceed via the interfaces 1–2 and 2–3 with an expansion of the active interface areas from the three-phase boundary in the directions indicated by the two arrows in the

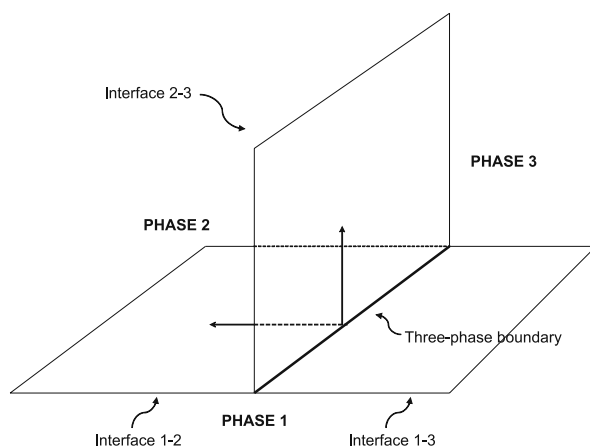

Three-phase boundary — Figure. A three-phase boundary resulting from joining of three phases

Figure. For a modeling of the coupled ion and electron transfer at a three-phase boundary see [v–vii]. Three-phase boundaries play a crucial role in → *fuel cells*, and many electrochemical → *sensors*.

Refs.: [i] Scholz F, Schröder U, Gulaboski R (2005) *Electrochemistry of immobilized particles and droplets*. Springer, Berlin; [ii] Deng Y, Wang D, Xiao W, Jin X, Hu X, Chen GZ (2005) *J Phys Chem B* 109:14043; [iii] Oldham KB (1998) *J Solid State Electrochem* 2:367; [iv] Hasse U, Wagner K, Scholz F (2004) *J Solid State Electrochem* 8:842; [v] Lovrić M, Scholz F (1999) *J Solid State Electrochem* 3:172; [vi] Schröder U, Oldham KB, Myland JC, Mahon PJ, Scholz F (2000) *J Solid State Electrochem* 4:314; [vii] Lovrić M, Scholz F (2003) *J Electroanal Chem* 540:89

FS

Three-phase electrodes — Electrodes at which three phases are involved in the electrochemical reaction. See → *three-phase boundary*.

FS

Throwing power — Throwing power refers to the ability of a plating solution (→ *electroplating*) to produce a relatively uniform distribution of metal upon a → *cathode* of irregular shape. Its quantity is determined by a quantity Wa , → *Wagner number*, which itself often describes the secondary current distribution in terms of dimensionless numbers of the form: $Wa = \kappa(d\eta/dj)/l$ [i], where κ denotes the → *conductivity* of the solution, $d\eta/dj$ is the slope of the → *overpotential*–current curve under the above conditions, and l a characteristic length of the system, for instance, the radius of a disc electrode. The secondary current distribution applies, when the influence of the overpotential cannot be neglected but concentration overpotential is negligible. The terms ‘throwing power’ and ‘macrothrowing power’ are especially applied to the ability of a solution to deposit in recessed areas, whereas ‘microthrowing power’ refers to the leveling ability of a plating bath (→ *electroplating*). As a rule of thumb, the throwing power is increased by low solution concentrations and low temperatures, whereas reduced by a good agitation.

Ref.: [i] *Pure Appl Chem* (1981) 53:1863; [ii] Paunovic M, Schlesinger M (2006) *Fundamentals of electrochemical deposition*, Wiley, New York, p 212

MHer

Time constant → *response time*

Time domain → *time scale*

Time-of-flight measurements — In the context of an electrochemical measurement a time-of-flight experiment is designed to measure the diffusion coefficient of

a redox moiety. A redox species is produced at a “generating” → *electrode* and its appearance detected at a “collector” electrode. Geometries can vary. An early example used an → *interdigitated array* [i]. The time-of-flight approach is particularly useful for quantifying the diffusion coefficient when the bulk concentration of the redox moiety and/or the number of electrons transferred are unknown.

Ref.: [i] Feldman BJ, Feldberg SW, Murray RW (1987) *J Phys Chem* 91:6558

SWF

Time scale

1. The time given on the axis of a graph.
2. The time domain on a window accessed by a given experiment or technique, e.g., femtosecond, picosecond, microsecond, millisecond. The time scale (or domain) is often characterized by a set of physical parameters associated with a given experiment or technique, e.g., r_0^2/D (for → *ultramicroelectrode* experiments) – thus if the electrode radius is $\sim 10^{-7}$ cm and the → *diffusion coefficient* $D = 1 \times 10^{-5}$ cm²/s⁻¹ the time scale would be $\sim 10^{-9}$ s. Closely related to the operative kinetic term, e.g., the time domain that must be accessed to measure a first-order → *rate constant* k_1 (s⁻¹) will be $1/k_1$; the time domain that must be accessed to measure a given heterogeneous rate constant, k will be D/k^2 . In → *cyclic voltammetry* this time domain will be achieved when $RT/F|v| = D/k^2$; with an ultramicroelectrode this time domain will be achieved (in a steady-state measurement when $r_0^2/D = D/k^2$ or $r_0 = D/k$ at a microelectrode [i–ii]).
3. (Dimensionless) time parameter or characteristic time scale: Any dimensionless combination of time (s) and physical parameters, e.g., Dt/r_0^2 , k_1t , $k_1r_0^2/D$ (for ultra microelectrodes), RT/Fv for cyclic voltammetry, ω^{-1} for AC methods [i–ii].

Refs.: [i] Bard AJ, Faulkner LR (2001) *Electrochemical methods*, 2nd edn. Wiley, New York, pp 479, 480; [ii] Bond AM (2002) *Broadening electrochemical horizons*. Oxford University Press, Oxford, pp 95–100

AMB

Tiselius, Arne Wilhelm Kaurin



(© The Nobel Foundation)

(Aug. 10, 1902, Stockholm, Sweden – Oct. 29, 1971, Uppsala, Sweden) Tiselius studied chemistry in Uppsala and joined the laboratory of → *Svedberg* in 1925. In 1930 he received the Ph.D. for his thesis entitled “The moving-boundary method of studying the electrophoresis of proteins”. In 1937, a research professorship was established for Tiselius. His fundamental work in developing → *electrophoresis* was encouraged and supported by Svedberg. In 1948 he was awarded the Nobel Prize in Chemistry for his achievements in electrophoresis and adsorption analysis.

Ref.: [i] <http://nobelprize.org/index.html>

FS

Titanium — Titanium (Ti) is a transition metal of the fourth group in the periodic table with an atomic weight of 47.867 g mol⁻¹ and an electronic configuration of (Ar)3d²4s². Ti is a highly important structural metal with two crystal structures: an α phase with hexagonal structure and a β phase with a bcc structure. The α phase is the most common allotropic structure and it transforms to the β phase at 882.5 °C. Electrochemically, titanium exhibits the characteristics of a → *valve metal*. When titanium is biased positively in aqueous solutions, an electrically isolating oxide film is developed, with a thickness that depends on electron tunneling, of the order of several nanometers to several tens of nanometers. Titanium is characterized by low density (4.506 g cm⁻³ for the α phase and 4.4 g cm⁻³ for the β phase), and high strength, and thus it exhibits a high strength-to-density ratio. Titanium has nonmagnetic properties, a vicker hardness of 80–100 and a thermal conductivity of 21.9 W m⁻¹ K⁻¹ at 25 °C. Titanium is a highly reactive metal (when it is not passivated) and reacts vigorously with atmospheric components. However, titanium and titanium alloys exhibit excellent → *corrosion* resistance due to the formation of a highly organized and compact passivation layer on its surface,

mainly TiO_2 . This excellent corrosion resistance applies also towards aqueous acid or base environments. Titanium is mostly abundant in mineral sands containing ilmenite FeTiO_3 or rutile TiO_2 (a white pigment used in paints, paper, etc.). Although titanium compounds are the fourth most abundant structural minerals on earth, titanium metal is relatively expensive due to its high refining costs. Pure titanium metal is commonly produced from TiCl_4 , which is prepared from ilmenite or rutile and is used as a precursor after purification for titanium production. Plating titanium on another metal or other objects can provide good environmental stability properties of titanium as a passive metal at lower costs, compared to the use of parts made from pure titanium. Due to the high melting point of titanium (1670°C), plating titanium by immersing parts in the molten metal is not realistic. The alternative, \rightarrow *electrodeposition*, has never proved to be feasible. Titanium can not be deposited from aqueous solutions due to the active nature of the metal. Efforts to develop non-aqueous solutions or low-temperature molten salt baths for this purpose have not been successful so far. There are several studies reporting very thin titanium deposition from an ionic liquid at room temperature, e.g., using TiCl_4 in *l*-methyl-3-butyl-imidazolium bis (trifluoromethyl sulfone) imide. Attempts to electrodeposit pure titanium from organic baths yielded only alloys of no more than 7% titanium with boron and aluminum. Several layers of titanium were successfully electrodeposited from several aromatic-based solutions with TiCl_4 and silver ions. Stable titanium compounds of a variety of oxidation states, $-I$, 0 , II , and III $\text{Ti}(IV)$, are known, although the latter is by far the most common. The standard potential for the Ti/Ti^{+2} couple is -1.63 V , -0.37 V for $\text{Ti}^{+2}/\text{Ti}^{+3}$, and -0.86 V for the Ti/TiO_2 couple, all at 25°C . Titanium coated by other materials such as platinum, lead oxide, iridium oxide, ruthenium oxide etc. is being used as a relatively highly stabilized anode. Coated titanium anodes are being used mainly in the \rightarrow *chlor-alkali* and desalination industries. Titanium dioxide is used extensively as a photocatalyst due to its many advantages, e.g., it is chemically and biologically inert, nontoxic, nonexpensive, and has good thermal stability. In addition, TiO_2 is the most active photocatalyst compared to other metal oxide semiconductors with a band gap energy of 3.0 eV for rutile and 3.2 eV for anatase. Recently, TiO_2 at Li_xTiO_y were found to be interesting Li insertion materials and can be used as relatively high-rate anode materials. Their redox activity is around 1.5 V vs. Li/Li^+ . This relatively high potential for anodes means, on the one hand, Li-ion bat-

teries with a low voltage, but on the other hand, minimal complications due to side reactions with solution species.

Refs.: [i] Lutjering G, Williams JC (2003) *Titanium*. Springer, New York; [ii] Leyens C, Peters M (2003) *Titanium and titanium alloys*. Wiley-VCH, New York; [iii] Stern KH (1996) *Metallurgical and ceramic protective coatings*. Springer, New York; [iv] Kaesche H (2003) *Corrosion of metals*. Springer, New York; [v] Lindstrom H, Soldergren S, Solbrand A, Rensmo H, Hjelm J, Hagfeldt A, Lindquist SE (1997) *J Phys Chem B* 101:7717; [vi] Kavan L, Fattakhova D, Krtil P (1999) *J Electrochem Soc* 146(4):1375

DA, HE

Titer — The mass of a chemical reagent which is equivalent to 1 cm^3 of a \rightarrow *standard solution* [i].

Ref.: [i] IUPAC (1997) *Compendium of chemical terminology*

FG

Titrand — A solution containing the \rightarrow *analyte* to which the \rightarrow *titrant* is added [i].

Ref.: [i] Harris D (2002) *Quantitative chemical analysis*. WH Freeman, New York

FG

Titrant — A reagent of known concentration that is added to the \rightarrow *titrand* to react with the \rightarrow *analyte* [i].

Ref.: [i] Harris D (2002) *Quantitative chemical analysis*. WH Freeman, New York

FG

Titration — A process for quantitative analysis in which measured increments of a \rightarrow *titrant* are added to a solution of an \rightarrow *analyte* until the reaction between the analyte and titrant is considered as complete at the \rightarrow *end point* [i]. The aim of this process is to determine the amount of an analyte in a \rightarrow *sample*. In addition, the determination can involve the measurement of one or several physical and/or chemical properties from which a relationship between the measured parameter/s and the concentration of the analyte is established. It is also feasible to measure the amount of a \rightarrow *titrand* that is added to react with a fixed volume of titrant. In both cases, the \rightarrow *stoichiometry* of the reaction must be known. Additionally, there has to be a means such as a \rightarrow *titration curve* or an \rightarrow *indicator* to recognize that the \rightarrow *end point* has been reached. The nature of the reaction between the titrant and the analyte is commonly indicated by terms like acid–base, complexometric, redox, precipitation, etc. [ii]. Titrations can be performed by addition of measured volume/mass increments of a solution,

or measured charge increments delivered by an electrode. Electrochemically, the charge increments can produce the reagent necessary for the titration reaction or intercalate/de-intercalate a component in/from a solid solution (\rightarrow *coulometric titration*). Solutions or mixtures of liquids, solids [iii–v], and gases can be titrated (\rightarrow *gas titrations*).

Refs.: [i] Skoog D, West D, Holler F, Crouch SR (2003) *Fundamentals of analytical chemistry*, 8th edn. Brooks/Cole, Belmont; [ii] IUPAC (1997) *Compendium of chemical terminology*; [iii] Watanabe N, Kuwana T (1980) *Anal Chem* 52:1657; [iv] Wagner C (1953) *J Chem Phys* 21:1819; [v] Kröger FA (1964) *The chemistry of imperfect crystals*. North-Holland, Amsterdam

FG, VK, FS

Titration curve — A plot of a variable or function, usually linearly or logarithmically related to the concentration (\rightarrow *activity*) of the \rightarrow *analyte*, versus the volume of \rightarrow *titrant* added or the \rightarrow *degree of titration*. Two kinds of titration curves are commonly found, the first type is called \rightarrow *linear titration curve* while the second one is denominated \rightarrow *logarithmic titration curve*. These curves are helpful in judging the feasibility of a \rightarrow *titration* and in selecting the proper \rightarrow *indicator* [i].

Ref.: [i] Mendham J, Denney R, Barnes J, Thomas M (2000) *Vogel's quantitative chemical analysis*. Prentice Hall, New Jersey

FG

Titration error — A numerical difference in volume, charge, or mass between the \rightarrow *equivalence point* and the \rightarrow *end point*. It is commonly related to a systematic \rightarrow *error* that can be corrected by carrying out a \rightarrow *blank determination*. See also \rightarrow *error (of measurement)* [i].

Ref.: [i] Harris D (2002) *Quantitative chemical analysis*. WH Freeman, New York

FG

Titrimetry — A chemical analysis based on determining the quantity of \rightarrow *titrant* that is required to react completely with the \rightarrow *analyte* and that is performed by \rightarrow *titration*. There are three common types of titrimetry: \rightarrow *volumetric titrimetry*, \rightarrow *gravimetric titrimetry*, and \rightarrow *coulometric titrimetry* [i].

Ref.: [i] Harris D (2002) *Quantitative chemical analysis*. WH Freeman, New York

FG

Tobias, Charles W.



(Nov. 2, 1920, Budapest, Hungary – Mar. 6, 1996, Orinda, California, USA) Tobias attended the Technical University in Budapest where he obtained his diploma (1942) and a Ph.D. in chemical engineering (1946). He pursued postdoctoral studies at the University of California, Berkeley, where he became an assistant professor in 1950. He was appointed a full professor in 1960. He served as president of the \rightarrow *Electrochemical Society* (1970–71) and as president of the \rightarrow *International Society of Electrochemistry* (1977–78). He is considered as the founding father of electrochemical engineering. Among others he studied ozone production, \rightarrow *electrodeposition* of alloys and metals, \rightarrow *electrochemical machining* of hard alloys, \rightarrow *batteries*, modeling of the impact of bubbles on current distribution and cell voltage.

Refs.: [i] <http://www.berkeley.edu/news/media/releases/96legacy>; [ii] McIntyre J (2002) *J Electrochem Soc* 149:S79; [iii] Tobias CW (1994) *Electrochem Soc Interface* 3:17

GI

Tommasi pile — Was essentially a \rightarrow *Bunsen cell*; however, constructed in such a way that the sulfuric acid could be easily filled in and replaced.

Ref.: [i] Hauck WP (1883) *Die Galvanischen Batterien, Accumulatoren und Thermosäulen*, 2nd edn. Hartleben's Verlag, Wien

FS

Total velocity of the analyte (in capillary electrophoresis), v_{tot} — The sum of the \rightarrow *electrophoretic velocity*, v_{ep} , of an ion and the \rightarrow *electroosmotic velocity*, v_{eo} .

$$v_{\text{tot}} = v_{\text{ep}} + v_{\text{eo}} .$$

This quantity can be measured experimentally as the effective length of the capillary divided by the \rightarrow *migration time* ($v_{\text{tot}} = L_{\text{eff}}/t_{\text{m}}$). Depending on the signs and relative magnitudes of these velocities, direction of the total velocity of an analyte can be either the same or opposite to that of the electroosmotic velocity. The total velocity

is the velocity of the ion measured as a displacement relative to the capillary wall divided by time.

Ref.: [i] Riekkola ML, Jönsson JA, Smith RM (2004) *Pure Appl Chem* 76:443

WK

Tracer methods — [i] The application of radiotracer methods in electrochemistry dates back to the pioneering works by → *Hevesy* in 1914. The aim of these studies was to demonstrate that isotopic elements can replace each other in both → *electrodeposition* and equilibrium processes (Nernst law → *Nernst equation*). Nevertheless, Joliot's fundamental work in 1930 is considered by electrochemists as a landmark in the application of → *radiochemical (nuclear) methods in electrochemistry*.

The main advantages of using radiotracers are as follows:

- The radiation emitted by radiotracers is generally easy to detect and measure with high precision.
- The radiation emitted is independent of pressure, temperature, chemical and physical state.
- Radiotracers do not affect the system and can be used in nondestructive techniques.
- The radiation intensities measured furnish direct information concerning the amount of the labeled species and no special models are required to draw quantitative conclusions.

The main fields in electrochemistry studied by tracer technique are:

- Dissolution and deposition of metals.
- → *electrosorption* phenomena at metal/solution interfaces.
- → *adsorption* at oxide/solution interfaces.

In the case of metal dissolution studies the principle of the methods used is based on the labeling of a component of the metal phase by one of its radioactive isotopes and calculating the dissolution rate of the metal specimen by measuring either the increase in radiation coming from the solution phase, or the decrease in radiation coming from the solid phase.

The main steps here are:

- Introduction of the radioisotope into the specimen. The task can be achieved at least by three methods: (a) through melting, (b) by electrolytic deposition

of the radioactive metal, and (c) by subjecting the metal specimen to neutron irradiation in a nuclear reactor.

- Measurement of the changes in radiation intensity caused by the dissolution process.
- A variation is the application of β backscattering for the study of the electrochemical formation and dissolution of thin metal layers.

Various methods have been developed for in situ radiotracer adsorption studies depending on the requirements of the problems to be studied. In the case of the in situ studies the central problem is how to separate the signal (radiation) to be measured from the background radiation, and how to attain the optimal ratio of these quantities.

From this point of view methods can be divided into two main groups:

- Radiation of the solution background is governed and minimized by self-absorption of the radiation, i.e., by the attenuation of the radiation intensity by the radioactive medium itself (thin-foil method).
- Background radiation intensity is minimized by mechanical means (thin-gap method, electrode lowering technique).

As to the role of the labeled species in the radiotracer study of adsorption phenomena, two different versions of the method may be distinguished. In the first, the direct method, the species to be studied is labeled and the radiation measured gives direct information on the adsorption of this species. However, this method cannot be used in several cases owing to technical restrictions related to the very nature of the radiotracer method (the available concentration range is limited; no distinction can be made between the adsorption of the labeled compound studied and that of a product formed from it; the number of commercially available labeled compounds is restricted.)

In the case of indirect radiotracer methods, instead of labeling the species to be studied another adequately chosen labeled species (the indicator species) is added to the system and the adsorption of this component is followed by the usual radiotracer measuring technique. The adsorption of the indicator species should be related to that of the species studied. The nature of this link could vary in different systems.

The radiotracer technique offers a unique possibility of demonstrating the occurrence of → *specific adsorption*

of an ion by labeling it and studying its adsorption in the presence of a great excess of other ions, electrolytes (supporting electrolyte). For these studies at least a difference of one to two orders of magnitude in concentrations should be considered. Under such conditions with nonspecific \rightarrow *adsorption*, determined by coulombic interactions, no significant adsorption of the labeled species, present in low concentration, could be observed. In contrast to this, the observation of a measurable adsorption can be considered as a proof of the occurrence of the specific adsorption.

Various versions of tracer methods were applied for studies of electrodes with polycrystalline smooth or rough surfaces and well-defined surfaces [ii].

Refs.: [i] Horanyi G (2004) In: Horanyi G (ed) *Radiotracer studies of interfaces. Interface science and technology*, vol. 3. Elsevier, Amsterdam, pp 39–92; [ii] Krauskopf EK, Chan K, Wieckowski A (1987) *J Phys Chem* 91:2327

GH

Transfer coefficient \rightarrow *charge transfer coefficient*

Transference (concentration cells with/without transference) \rightarrow *concentration cells*

Transference number \rightarrow *transport number*

Transient technique — A technique whose response is time dependent and whose time dependence is of primary interest, e.g., \rightarrow *chronoamperometry*, \rightarrow *cyclic voltammetry* (where current is the transient), \rightarrow *chronopotentiometry* and \rightarrow *coulostatic techniques* (where voltage is the transient). A transient technique contrasts with steady-state techniques where the response is time independent [i]. Some good examples are cyclic voltammetry [i, ii] (fast scan cyclic voltammetry), the indirect-laser-induced-temperature-jump (ILIT) method [iii], coulostatics [i]. The faster the transient technique, the more susceptible it is to distortion by \rightarrow *adsorption* of the redox moiety.

Refs.: [i] Bard AJ, Faulkner LR (2001) *Electrochemical methods*, 2nd edn. Wiley, New York, pp 487–516; [ii] Amatore C, Maisonhaute E (2005) *Anal Chem* 77:303A; [iii] Feldberg SW, Newton MD, Smalley JF (2003) *The indirect laser-induced temperature jump method for characterizing fast interfacial electron transfer: concept, application, and results*. In: Bard AJ, Rubinstein I (eds) *Electroanalytical chemistry*, vol. 22. Marcel Dekker, New York, pp 101–180

AMB

Transition state — is a state in \rightarrow *elementary reactions* of more positive molar \rightarrow *Gibbs energy* between the reactants and the products through which an assembly of

atoms (initially composing the molecular entities of the reactants) must pass on going from reactants to products in either direction. In the formalism of “transition state theory” the transition state of an elementary reaction is that set of states (each characterized by its own geometry and energy), whose assembly of atoms, when randomly placed there, would have an equal probability of forming the reactants or products of that elementary reaction. The transition state is characterized by one, and only one, imaginary frequency. The assembly of atoms in the transition state has been called an activated complex.

Calculations of \rightarrow *reaction rates* by the transition-state method and based on calculated \rightarrow *potential-energy surfaces* refer to the potential-energy maximum at the saddle point, as this is the only point for which the requisite separability of transition-state coordinates may be assumed. The ratio of the number of assemblies of atoms that pass through to the products to the number of those that reach the saddle point from the reactants can be less than unity, and this fraction is the “transmission coefficient”, κ . (There are also reactions, such as the gas-phase colligation of simple radicals, that do not require “activation” and which therefore do not involve a transition state.) See also \rightarrow *Gibbs energy of activation*, \rightarrow *potential energy profile*, \rightarrow *Polányi*.

Ref.: [i] Muller P (1994) *Pure Appl Chem* 66:1077

WK

Transition time (for chronopotentiometry) — Electrolysis time required before the surface concentration of a redox species drops to zero in \rightarrow *chronopotentiometry*. In constant-current chronopotentiometry (see also \rightarrow *constant-current techniques*), the transition time τ is given by the \rightarrow *Sand equation*:

$$\tau^{1/2} = \frac{nFA\sqrt{\pi D}c^*}{2|I|},$$

where A is the electrode area, I is the current, and D and c^* are the \rightarrow *diffusion coefficient* and bulk concentration of the redox species, respectively.

Ref.: [i] Bard AJ, Faulkner LR (2001) *Electrochemical methods*, 2nd edn. Wiley, New York

TO

Transmission — This term is used to describe the passage of an electromagnetic wave (light beam, X rays etc.) or accelerated particles (electrons, various ions, atoms, clusters, or molecules) through a condensed medium. This process is accompanied by interactions of various kinds with the medium resulting in absorption of the

electromagnetic energy or particles and in their elastic and inelastic scattering (without or with energy losses), the latter being frequently accompanied by the emission of secondary beams or fluxes. These factors lead to a diminution of the intensity of the flux/beam which is characterized by the \rightarrow *transmission coefficient*. Its measurement is used in various spectroscopies (UV-visible, IR, TEM...). Other experimental techniques are based on the registration of the emissions or fluxes generated by the excitation beam (SEM, EDX, XPS, SIMS, spectroscopies Raman, ESR, and NMR...).

MAV

Transmission coefficient — The \rightarrow *transmission coefficient*, T , also called transmittance, for an electromagnetic wave or a particle flux passing through a layer is defined as the ratio of the intensities of the transmitted and incident beams: $T = I_t/I_o$. Percent transmittance is $T \times 100\%$. These parameters are usually measured in a broad interval of wavelengths or wave numbers (in optical spectroscopies) or of particle energies, giving a transmission spectrum, e.g., $T(\lambda)$. In the practical measurements of spectra with a spectrophotometer one must take into account the intensity losses within the device itself which are characterized by the spectrum measured without a system under study, $T_o(\lambda)$. Then, their ratio gives the corrected transmission spectrum, $T'(\lambda) = T(\lambda)/T_o(\lambda)$. There are several options in the choice of the reference system for this operation: measurement without a cell or with an empty cell or with a cell filled by the pure solvent/background electrolyte etc. which may sometimes affect significantly the corrected spectrum.

The decimal logarithm of the transmission coefficient is called absorption: $A = \log(1/T)$, or $A' = \log(1/T')$ for the corrected transmission. The latter quantity can be measured directly in a double-beam spectrophotometer (by use of the corresponding system for the second beam) or by a memorization of the reference spectrum and its subtraction from the curve measured for the system under study of the single-beam device.

MAV

Transmission line — This term is related to a more general concept of electric \rightarrow *equivalent circuits* used frequently for interpretation of experimental data for complex impedance spectra (\rightarrow *electrochemical impedance spectroscopy*). While the complex \rightarrow *impedance*, Z , at a fixed frequency can always be obtained as a series or parallel combinations of two basic elements, a resistance and a capacitance, it is a much more compli-

cated problem to construct such a circuit of frequency-independent resistances and capacitances for the whole impedance spectrum, $Z(f)$. Moreover, one can easily prove that it is impossible to find such a circuit composed of a **finite** number of elements even for one of the simplest elements of electrochemical systems, \rightarrow *Warburg impedance*: $W = \text{const}/f^{1/2}$, since the latter shows nonanalytical behavior for low frequencies. Therefore, the adequate \rightarrow *equivalent circuits* have to be constructed either from frequency-dependent elements (e.g., including this element, W) or by use of an **infinite** number of standard elements. The latter approach introduces “distributed elements”, which represent a set of the infinite number of infinitesimal elements. In particular, the Warburg impedance function for the whole range of frequencies can be reproduced by a transmission line:

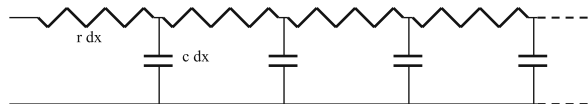

Transmission line — Figure

Here, the potential and the current distributions in the upper line (the lower line is non-resistive and grounded) are given by the differential equations: $I(x) = -r\partial V/\partial x$, while the change (as a function of time) of the charge at each capacitive elements, $dq = cV(x)dx$, is balanced by the diminution of the current in the upper line, $-dI$, which gives: $c\partial V/\partial t = -\partial I/\partial x$. Their combination leads to an analog of the nonstationary Fick equation: $cr\partial V/\partial t = \partial^2 V/\partial x^2$ (\rightarrow *Fick's law*), whose solution gives the expression for impedance of this semi-infinite transmission line: $Z_{TL} = (r/i\omega c)^{1/2}$, which is equivalent to the Warburg impedance function (after a proper choice of the circuit parameters, r and c).

The above circuit (where the elements are distributed in the interval, $0 < x < \infty$) represents an analog of a semi-infinite diffusion. Similar circuits but with a distribution at a limited interval, $0 < x < L$, correspond to a finite diffusion and lead to two different expressions for the finite Warburg impedance depending on the way of terminating the upper line at $x = L$, with a resistor, R , or an open circuit. The introduction of the distributed resistance elements along the lower line results in a circuit which reproduces the response of a semi-infinite or a finite (depending on the infinite or finite length of the lines) mixed conductor. The effects of passage of a displacement current through a medium can be simulated in such equivalent circuits by an extra (third) line.

Refs.: [i] Retter U, Lohse H (2005) *Electrochemical impedance spectroscopy*. In: Scholz F (ed) *Electroanalytical methods*. Springer, Berlin, chap II.5; [ii] Barsoukov E, Macdonald JR (ed) (2005) *Impedance spectroscopy. Theory, experiment, and applications*. Wiley, Hoboken

MAV

Transmissive boundary — This type of interface represents an opposite case with respect to a \rightarrow *blocking* or \rightarrow *reflecting boundary* [i]. A transmissive boundary allows the transfer of the electric charge across the interface. In the simplest case (chemically) the same ion may propagate through both media in contact and the interface does not impose a too high energetic barrier for its exchange between the phases (metal cation for a solution|amalgam interface, some ions present in both contacting immiscible liquids, solution|lithium cation intercalation layers, contacts of \rightarrow *solid electrolytes* with the same mobile cation, interface between a \rightarrow *conducting polymer* film and a solution as a reservoir of counter ions etc.). In a more complicated case the chemical composition of the corresponding mobile ion \rightarrow *charge carriers* may be different in the contacting phases, e.g., the ion may form a complex to enter another phase. Another type of transmissive boundaries allows interfacial \rightarrow *electron transfer*. In the simplest variant this boundary separates two electron-conducting media (metal|metal, metal|semiconductor, semiconductor|semiconductor) and the passage of an electric current results generally in a change of the interfacial potential difference (“ohmic contact”). Its electrochemical examples are: metal|solution containing electroactive species, metal|electron-conducting polymer film, redox reaction at the interface of two immiscible liquids. Finally, there are permissive interfaces which may allow the exchange by several charged species, e.g., by several ions (mixture of alkali ions in some solid electrolytes) or a parallel transfer of ion and electron charges (electron-conducting polymer|solution containing counter ions and electroactive species). A specific example of such a system is the \rightarrow *diffusion* boundary layer in solution near the electrode surface which allows the exchange of all solute species with the bulk solution: there is really no interface between these two areas of the solution but most predictions of the \rightarrow *Nernst (diffusion) layer* model (in which the diffusion layer is separated by a transmissive interface from the bulk solution) correspond to those of the more substantiated description.

By definition, the transmissive boundary between phases α and β allows the passage of a \rightarrow *faradaic current* owing to the interfacial transfer of the corresponding

charged species j under the influence of the difference of their \rightarrow *electrochemical potentials* across the interface, $\bar{\mu}_j^\alpha$ and $\bar{\mu}_j^\beta$ [ii–iv]. Generally, this difference is nonzero under nonequilibrium conditions, i.e., the transfer process is resistive, the corresponding interfacial current being proportional to this thermodynamic driving force: $I_j = (\bar{\mu}_j^\alpha - \bar{\mu}_j^\beta) / (z_j F R_j^{\alpha\beta})$, z_j being the charge valency of the exchanged species, $R_j^{\alpha\beta}$, ion or electron transfer resistance between phases α and β . If this resistance is sufficiently small the interface may be considered as “ideally permeable” with respect to this kind of species which means the equality of $\bar{\mu}_j^\alpha$ and $\bar{\mu}_j^\beta$ across the interface even in nonequilibrium conditions. For the case of the electron transfer at an electrode|solution boundary it corresponds to \rightarrow “*nonpolarizable electrodes*”.

An important example of the system with an ideally permeable external interface is the diffusion of an electroactive species across the boundary layer in solution near the solid electrode surface, described within the framework of the Nernst diffusion layer model. Mathematically, an equivalent problem appears for the diffusion of a solute electroactive species to the electrode surface across a passive membrane layer. The non-stationary distribution of this species inside the layer corresponds to a finite \rightarrow *diffusion* problem. Its solution for the film with an ideally permeable external boundary and with the concentration modulation at the electrode|film contact in the course of the passage of an alternating current results in one of two expressions for “finite-Warburg impedance” for the contribution of the layer: $Z_{\text{layer}} = R(0) \tanh(i\omega\tau_d)^{1/2} / (i\omega\tau_d)^{1/2}$ containing the characteristic \rightarrow *diffusion time*, $\tau_d = L^2/D$ (L , layer thickness, D , \rightarrow *diffusion coefficient*), and the low-frequency resistance of the layer, $R(0) = dE/dI$, this derivative corresponding to \rightarrow *direct current* conditions.

Refs.: [i] Retter U, Lohse H (2005) *Electrochemical impedance spectroscopy*. In: Scholz F (ed) *Electroanalytical methods*. Springer, Berlin, chap II.5; [ii] Vorotyntsev MA, Badiali JP, Viel E (1996) *Electrochim Acta* 41:1375; [iii] Vorotyntsev MA, Badiali JP, Inzelt G (1999) *J Electroanal Chem* 472:7; [iv] Vorotyntsev MA (2002) *Electrochim Acta* 47:2071

MAV

Transpassivity — Certain metals exhibit the property of \rightarrow *passivity*, whereby the metal resists \rightarrow *corrosion* under conditions in which it should react significantly, usually due to the formation of an oxide or hydroxide film of limited ionic conductivity (a passive film) that separates the metal from the corrosive environment. An

odic polarization above some potential E_t (see \rightarrow *passivity* and the figure therein) results in an increase in the corrosion rate (thus, current) and the metal is said to exhibit transpassivity [i]. For most metals, this increase in corrosion rate occurs because the oxide film dissolves rather uniformly, often accompanied by oxygen evolution. For example, this occurs for stainless steels when the Cr_2O_3 passive oxide film (with chromium in the Cr^{3+} state) is further oxidized to chromate (with chromium in the Cr^{6+} state). Since the chromate is soluble, the passive film is lost and corrosion occurs. If an aggressive species such as chloride ion is present, the dissolution can become nonuniform. For the valve metals (e.g., aluminum, tantalum, titanium, lead), anodic polarization under certain conditions leads not to metal dissolution, but rather to the growth of a thick, insulating oxide film, a process known as \rightarrow *anodization*.

Ref.: [i] Schultze JW, Hassel AW (2006) *Passivity of metals, alloys, and semiconductors*. In: Bard AJ, Stratmann M, Frankel GS (eds) *Corrosion and oxide films*. *Encyclopedia of electrochemistry*, vol. 4. Wiley-VCH, Weinheim, pp 216–270

T

Transport entropy \rightarrow *heat of transport*

Transport number — Transport number of the ionic species B (t_B) in an \rightarrow *electrolyte solution* [i, ii] or \rightarrow *solid electrolyte*

$$t_B = \frac{\lambda_B c_B}{\sum_i \lambda_i c_i} = \frac{|z_B| F u_B c_B}{\sum_i |z_i| F u_i c_i}, \quad (1)$$

where λ_B ($\text{S m}^2 \text{ mol}^{-1}$), c_B (mol m^{-3}), z_B and u_B are the ionic \rightarrow *conductivity*, the \rightarrow *concentration* the \rightarrow *charge number* and electric \rightarrow *mobility* ($\text{m}^2 \text{ V}^{-1} \text{ s}^{-1}$) of ion B, respectively, λ_i , c_i , z_i , and u_i are the same quantities for other ions in the same solution, and F is the \rightarrow *Faraday constant*. The transport number (also called transference number [iii]) is the contribution of ion B to the overall \rightarrow *conductivity* ($\chi = \sum \lambda_i c_i$) of the electrolyte solution.

Transport numbers can be measured by several methods. The application of the Hittorf cell (\rightarrow *Hittorf transport method*), that was introduced in 1853, is still the most frequently used technique for the determination of the transport number [iv]. The ‘moving boundary’ method, analogous to that used by \rightarrow *Tiselius* to measure \rightarrow *electrophoretic mobilities* is also used to measure transport numbers [v]. See also \rightarrow *Tubandt method*.

Refs.: [i] Cohen ER, Cvitas T, Frey JG et al. (2007) *IUPAC quantities, units and symbols in physical chemistry*, 3rd edn; RSC Publishing, Cambridge [ii] Parsons R (1974) *Pure Appl Chem* 37:503; [iii] Bard AJ,

Faulkner LR (2001) *Electrochemical methods*, 2nd edn. Wiley, New York, pp 66–69; [iv] Hamann C, Hamnett A, Vielstich W (1998) *Electrochemistry*. Wiley, Weinheim, pp 26–32; [v] Rieger PH (1993) *Electrochemistry*. Chapman & Hall, New York, pp 116–118

GI

Transport phenomena — Transport is a process whereby species and other quantities move from one place to another. The most important transport phenomena involve the transfer of mass, energy (heat), momentum, and charge [i–vi].

In the case of \rightarrow *mass transport*, mass is transferred by \rightarrow *diffusion* between places with different \rightarrow *chemical potentials* (usually having different concentrations), or by electric conduction between places of different electric \rightarrow *potential*. Electric conduction also involves \rightarrow *charge transport* (migration). Energy transfer occurs in heat conduction between places of different thermal energy (temperature). In viscous flow, momentum transfer takes place between regions of a material system containing particles of different impulses. Transport phenomena can occur in every state of matter, but their rate is especially high in fluid phases. The rate of transport processes is proportional to gradients of concentration (chemical potential), electric potential, temperature, and impulse. The corresponding proportionality factors are the \rightarrow *diffusion coefficient*, electric conduction coefficient (electric \rightarrow *conductivity*), and \rightarrow *viscosity coefficient* (viscosity). Transport is often caused by local differences of more than one property, e.g., concentration and electric potential. Then cross-effects should also be taken into account (\rightarrow *Onsager reciprocal relations*).

A special case of diffusion is \rightarrow *self-diffusion* which is related to the displacement of species due to the thermal motion within a phase that is uniform in its properties (random motion).

In electrochemistry, transport processes are essential, since mass and charge transfer accompany almost all electrochemical processes.

There are general relationships of transport phenomena based on phenomenological theory, i.e., on the correlations between macroscopically measurable quantities. The molecular theories explain the mechanism of transport processes taking into account the molecular structure of the given medium, applying the kinetic-statistical theory of matter. The hydrodynamic theories are also applied especially to describe \rightarrow *convection*.

The most important relationships used are \rightarrow *Fick's laws* and \rightarrow *Einstein's equation* for diffusion, Newton's viscosity law and Stokes's law (\rightarrow *Stokes's viscous force*)

for viscosity, → *Stokes–Einstein equation* for the relationship between diffusion coefficient and frictional resistance (viscosity), → *Nernst–Einstein equation* describing the relationship between the diffusion coefficient and the → *mobility*, *Onsager–Fuoss equation* for the diffusion of electrolytes, → *Dahms–Ruff theory* for electron diffusion (electron exchange reaction, → *electron hopping*) in solutions, → *Smoluchowski equation* expressing the relation between the diffusion coefficients and the rate coefficient, → *Kohlrausch square-root law* of the independent migration of ions, → *Walden rule* regarding the (approximate) constancy of the product of viscosity and ionic mobility (diffusion coefficient) of ions and molecules, → *Debye–Hückel limiting law* for the variation of conductivity with concentration, and → *Debye–Falkenhagen effect* regarding the dispersion (frequency dependence) of conductivity. The → *Levich’s equation* is used in the case of convective → *diffusion* (→ *rotating disk electrode*) [ii, iv, vii, viii].

Refs.: [i] Erdey-Grúz T (1974) *Transport phenomena in aqueous solutions*. Hilger, London; [ii] Erdey-Grúz T (1972) *Kinetics of electrode processes*. Akadémiai Kiadó, Budapest; [iii] Oldham HB, Myland JC (1994) *Fundamentals of electrochemical science*. Academic Press, San Diego; [iv] Bard AJ, Faulkner LR (2001) *Electrochemical methods*, 2nd edn. Wiley, New York, pp 137–153; [v] Inzelt G (2002) *Kinetics of electrochemical reactions*. In: Scholz F (ed) *Electroanalytical methods*. Springer, Berlin, pp 29–48; [vi] Atkins PW (1995) *Physical chemistry*. Oxford University Press, Oxford, pp 817–861; [vii] Levich VG (1962) *Physicochemical hydrodynamics*. Prentice Hall, Englewood Cliffs; [viii] Newman JS (1973) *Electrochemical systems*. Prentice Hall, Englewood Cliffs

Traveling-wave dielectrophoresis — A special case of → *dielectrophoresis* where particles can be moved along an extended array of electrodes. The translational force is created by energizing the electrodes with poly-phase voltages to create an electrical traveling wave, as depicted below.

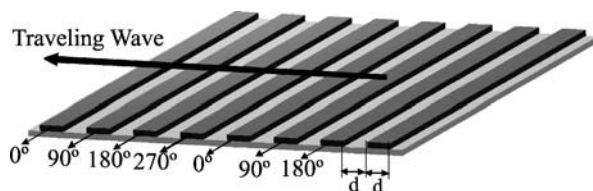

Traveling-wave dielectrophoresis — Figure

A traveling AC field is generated by sequentially addressing the electrodes with sinusoidal voltages of the

same frequency, and with a phase difference of 90° between consecutive electrodes [i, ii]. The direction of wave propagation is towards the smaller phase regions. Reversing this quadrature phase sequence causes the direction of wave propagation to reverse. The traveling wave has a wavelength λ equal to the distance between every fourth electrode, so that for the case shown here $\lambda = 8d$. The particles are suspended in a solution above the electrodes. The analogy can be made that the electrodes take the form of a flattened-out, and repeated, arrangement used for → *electrorotation* experiments, but instead of causing a particle to rotate it ‘rolls along’ the electrode array.

The electric field created by the electrodes induces a → *dipole moment* in the particle. This dipole moment either leads or lags the traveling field vector, depending on the frequency of the applied voltages and the charge relaxation times of the particle and surrounding fluid (→ *dielectric relaxation*). This phase difference between the rotating field and the induced dipole moment results in both a vertical and lateral dielectrophoretic force to be imparted on the particle. A translational movement of a particle along the electrode track can only occur for the situation where the particle is levitated above the electrodes by negative → *dielectrophoresis* and where a significant rotational force acts on it. The sense of this rotational force determines the direction of motion of the particle, either with or against the traveling field vector.

The electrodes need not take the form of parallel bars, but can take the form of circular tracks or junctions, for example, and can be fabricated using either photolithography or laser micromachining [iii]. By superimposing more than one signal frequency to the electrodes, very selective cell separations can be achieved, through careful choice of the suspension medium and the frequencies and strengths of the applied signals [iv].

Refs.: [i] Hagedorn R, Fuhr G, Müller T, Gimsa J (1992) *Electrophoresis* 13:49; [ii] Huang Y, Tame JA, Pethig R (1993) *J Phys D: Appl Phys* 26:1528; [iii] Pethig R, Burt JPH, Parton A et al. (1998) *J Micromech Microeng* 8:57; [iv] Pethig R, Talary MS, Lee RS (2003) *IEEE Eng Med Biol* 22(6):43

RP

Trickle charging — A continuous, low level, constant current charging of secondary → *batteries* (cells), with the purpose of maintaining the battery fully charged, offsetting spontaneous self-discharge or low current drain. Accomplished by a current source, with preset constant current, “trickle current”, that is carefully adjusted to maintain the battery in the fully charged condition, at

a certain voltage. This mode of charging is common for standby batteries, in particular lead–acid and nickel–cadmium batteries.

Refs.: [i] Hammel RO, Salkind AJ, Linden D (1994) *Sealed lead–acid batteries*. In: *Linden D Handbook of batteries*, 2nd edn. McGraw–Hill, New York, pp 25.29–25.30; [ii] Nagy Z (2005) *Online electrochemistry dictionary*. <http://electrochem.cwru.edu/ed/dict.htm>; [iii] Crompton TR (2000) *Battery reference book*, 3rd edn. Newnes, Oxford, pp 31/18–31/19, 32/6–32/7, 47/14–47/15

YG

Trouvé cell — This was a variant of the → *Daniell cell*. See also → *zinc*, → Zn^{2+}/Zn electrodes, → $Zn^{2+}/Zn(Hg)$ electrodes, → *zinc–air batteries (cell)*, and → *Leclanché cell*.

Ref.: [i] Hauck WP (1883) *Die Galvanischen Batterien, Accumulatoren und Thermo Säulen*, 2nd edn. Hartleben's Verlag, Wien

FS

Trouvé–Callaud cell — This was a variant of the → *Daniell cell*. See also → *zinc*, → Zn^{2+}/Zn electrodes, → $Zn^{2+}/Zn(Hg)$ electrodes, → *zinc–air batteries (cell)*, and → *Leclanché cell*.

Ref.: [i] Hauck WP (1883) *Die Galvanischen Batterien, Accumulatoren und Thermo Säulen*, 2nd edn. Hartleben's Verlag, Wien

FS

Trouvé pile — This was a chromic acid (carbon electrode) – zinc → *battery*. See also → *chromic acid battery*, → *Daniell cell*, → *zinc*, → Zn^{2+}/Zn electrodes, → $Zn^{2+}/Zn(Hg)$ electrodes, → *zinc–air batteries (cell)*, and → *Leclanché cell*.

Ref.: [i] Hauck WP (1883) *Die Galvanischen Batterien, Accumulatoren und Thermo Säulen*, 2nd edn. Hartleben's Verlag, Wien

FS

True electrode area → *electrode surface area*

True value — A value that would result if a measurement process were error-free. Since measurement uncertainties can never be completely eliminated, the true value of a measured quantity is always unknown. However, the term can be also assigned, by convention, to the value of a particular quantity whose associated error is considered as appropriate for a given purpose [i].

Ref.: [i] IUPAC (1997) *Compendium of chemical terminology*

FG

TTF⁺TCNQ⁻ electrode → *electrode, materials*, subentry → *tetracyanoquinodimethane electrodes*, and → *tetrathiafulvalene electrodes*

Tubandt, Carl



(Reproduced with permission of Leopoldina-Archiv, M 1 Matrikel 3500)

(Dec. 3, 1878, Halle, Germany – Jan. 17, 1942, Berlin, Germany) Tubandt studied science at the University of Halle, where he obtained his Ph.D. in 1904, and habilitated in 1907. In 1908 he worked with → *Nernst*. In 1912 he became titular Professor, in 1915 extraordinary Professor (assistant professor), and in 1921 full Professor at the University of Halle. Since 1931 he was Director of the Institute of Physical Chemistry. In 1937 he was expelled from the University by the Nazi authorities because his wife was Jewish. Two years after his death in 1942, his wife committed suicide in order not to be sent to a concentration camp.

Tubandt was a pioneer of → *solid state electrochemistry*. He introduced a methodology to determine the → *transport numbers* of ions in → *solid electrolytes* [i], which is now referred to as → *Tubandt method*. Together with his co-workers he performed seminal studies of conductivities and transport numbers of solid electrolytes, e.g., of silver, lead, and copper halides, and silver sulfide. He showed for the first time that the entire dark current of silver bromide is transported by silver ions, and also that slightly below the melting point silver iodide has a higher conductivity than the melt.

Refs.: [i] Tubandt C (1932) *Leitfähigkeit und Überföhrungszahlen in festen Elektrolyten*. In: Wien W, Harms F, Fajans K (eds) *Elektrochemie. Handbuch der Experimentalphysik*, vol. 12, part 1. Akadem Verlagsges, Leipzig, pp 381

FS

Tubandt method → *Tubandt* developed a special form of the → *Hittorf method* to determine → *transport numbers* (→ *Hittorf transport method*) in → *solid electrolytes*. Basically it consists in pressing the solid electrolyte in tablets or to cut sheets from single crystals, pressing them together, and passing current through the pile of tablets (1 to 5 in the figure). Weighing the tablets following the passage of a certain charge (→ *coulometer*) al-

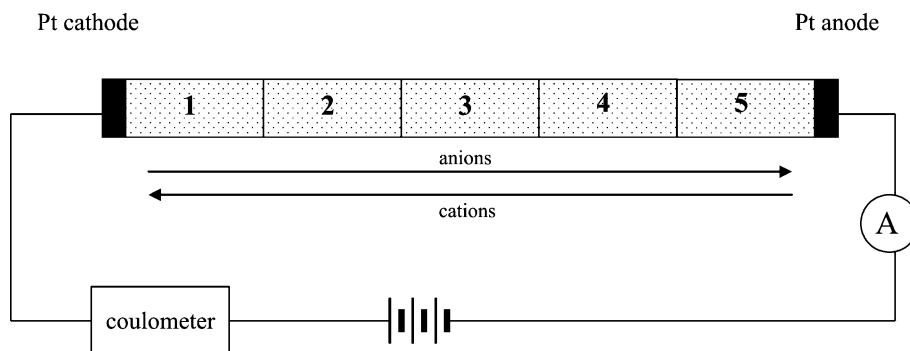

Tubandt method — Figure

allows calculating the transport number like in the classical Hittorf method. In many cases Tubandt used as tablet 1 and 5 (see figure) so-called ‘supporting electrolyte’ tablets. They were made from a salt that leads to a compact metal deposition when in contact with the cathode. Otherwise, when the electrolyte to be studied is in direct contact with the cathode, it often happens that the metal grows as whiskers through the electrolyte and leads to an electronic shortening of the metal electrodes. On the anode side it is also sometimes necessary to prevent the intrusion of anode products into the studied electrolyte. This again can be achieved by putting a suitable ‘supporting electrolyte’ tablet between the metal anode and the electrolyte. The Tubandt method is equally applicable to single-crystal and polycrystalline materials. Problems may be caused by high resistance between the tablets. The technique is also sometimes referred to as faradaic efficiency measurement as it relies on Faraday’s law.

Refs.: [i] Tubandt C (1932) *Leitfähigkeit und Überföhrungszahlen in festen Elektrolyten*. In: Wien W, Harms F, Fajans K (eds) *Elektrochemie. Handbuch der Experimentalphysik*, vol. 12, part 1. Akadem Verlagsges, Leipzig, pp 381; [ii] Riess I (1997) *Electrochemistry of mixed ionic-electronic conductors*. In: Gellings PJ, Bouwmeester HJM (eds) *Solid state electrochemistry*. CRC Press, Boca Raton, pp 223

Tubular electrode — Working electrode design employing a tube of the → *electrode* material to be studied with (i.e. secondary battery) the → *electrolyte* solution flowing through the orifice of the tube. This way well-defined forced convection of solution can be established. → *Mass transport processes* can be treated mathematically.

Refs.: [i] Singh T, Dutt J (1985) *J Electroanal Chem* 190:65; [ii] Dutt J, Gupta HO, Singh T, Parkash R (1988) *Analyst* 113:493; [iii] Singh T, Dutt J, Kaur S (1991) *J Electroanal Chem* 304:17; [iv] Singh T, Singh RP,

Dutt J (1995) *J Math Chem* 17:335; Compton RG, Sealy GR (1983) *J Electroanal Chem* 145:35

RH

Tungsten carbide → *electrode materials*, subentry → *tungsten carbide*

Tungsten oxides — Tungsten oxide, WO_3 , films have been intensely studied for possible electrochromic applications [i]. See → *electrochromism*, *electrochromic devices*. Tungsten oxide thin films may be prepared by numerous methods, including evaporation or sputtering of oxide, sol-gel deposition, spin-coating, dipping or spraying, chemical vapor deposition (CVD), and tungsten anodization [i–iv]. Tungsten oxide, with all tungsten sites in oxidation state W^{VI} , is transparent as a thin film. On electrochemical reduction, W^{V} sites are generated to give the electrochromic effect, in the following electrochemical reaction:

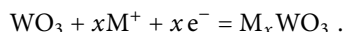

Although there is still controversy about the detailed coloration mechanism, it is generally accepted that the injection and extraction of electrons and metal cations ($\text{M}^+ = \text{H}^+, \text{Li}^+, \text{Na}^+, \text{or } \text{K}^+$) play a key role. The stated WO_3 stoichiometry is a simplification, thin films of practical interest being hydrous, and containing hydroxyl groups and incorporated water molecules [ii]. At low x the films have an intense blue color caused by intervalence charge transfer between adjacent W^{V} and W^{VI} sites. At higher x , insertion occurs irreversibly yielding a metallic “bronze” which is red or golden in color.

Refs.: [i] Granqvist CG (1995) *Handbook of inorganic electrochromic materials*. Elsevier, Amsterdam; [ii] Granqvist CG (2000) *Sol Energy Mater Sol Cells* 60:201; [iii] Granqvist CG, Avendaño E, Azens A (2003)

FS

Thin Solid Films 442:201; [iv] Avendaño E, Berggren L, Niklasson GA, Granqvist CG (2006) *Thin Solid Films* 496:30

RJM

Tungsten electrode (or tungsten–tungsten oxide electrode) → *pH sensitive electrodes*

Tunneling → *electron*, and → *proton*

Turbulent flow — arises at high Reynolds numbers and is characterized by the superposition upon the principal motion of a fluid, countless irregular and chaotic secondary components.



Turbulent flow — Figure. Schematic of turbulent flow through a pipe

These fluctuations may be caused by rapid variations in pressure or velocity producing random vortices and flow instabilities within the fluid. A complete mathematical analysis of turbulent flow remains elusive due to the erratic nature of the flow. Often used to promote mixing or enhance transport to surfaces, turbulent flow has been studied using electrochemical techniques [i].

Ref.: [i] Der-Tau C, Mitchell L (1972) *J Fluid Mech* 54:613

AF, SM

Turgor → *osmosis*

Two-electrode system — A system in which the → *working electrode* is polarized to a desired → *potential* vs. the → *reference electrode*. As a result, both electrodes pass → *current*. To preserve the constant potential of the reference electrode during the measurements, the reference electrode should be of large area and with high activities of the redox forms. This requirement can be

dropped when the → *three-electrode system* is used. Recently, the two-electrode system has rarely been applied. It is justified when a → *microelectrode* is employed as the working electrode.

Ref.: [i] Bard AJ, Faulkner LR (2001) *Electrochemical methods*, 2nd edn. Wiley, New York

ZS

Two-phase electrolysis — Electrolysis of two-phase systems, esp. of two liquid phases. The usual case is that an organic compound is dissolved in a nonaqueous solvent and that solution, together with an aqueous electrolyte solution is forced to impinge on an electrode. The electrolysis reaction of the dissolved organic compound can proceed via a small equilibrium concentration in the aqueous phase, or it can proceed as a reaction at the → *three-phase boundary* formed by the aqueous, the nonaqueous phase, and the electrode metal. A very effective way of delivering a two-phase mixture to an electrode is the use of a → *bubble electrode*.

Refs.: [i] Feess H, Wend H (1982) *Performance of two-phase-electrolyte electrolysis*. In: Weinberg NL (ed) *Techniques of electroorganic synthesis*. Wiley, New York, pp 81; [ii] Pragst F, Scholz F, Woitke P, Kollek V, Henrion G (1985) *J Prakt Chem* 327:1028

FS

Tyer cell — This was a → *battery* consisting of a platinized silver electrode and a bottom electrode of a mercury pool with pieces of zinc. The electrolyte is dilute sulfuric acid. See also → *zinc*, → *Zn²⁺/Zn electrodes*, → *Zn²⁺/Zn(Hg) electrodes*, → *zinc–air batteries (cell)*.

Ref.: [i] Hauck WP (1883) *Die Galvanischen Batterien, Accumulatoren und Thermosäulen*, 2nd edn. Hartleben's Verlag, Wien

FS

Tyer's pyrolusite cell — This was a variation of the → *Leclanché cell*. See also → *Daniell cell*, → *zinc*, → *Zn²⁺/Zn electrodes*, → *Zn²⁺/Zn(Hg) electrodes*, → *zinc–air batteries (cell)*.

Ref.: [i] Hauck WP (1883) *Die Galvanischen Batterien, Accumulatoren und Thermosäulen*, 2nd edn. Hartleben's Verlag, Wien

FS

U

Ultracapacitor — Electrolytic capacitors of very large capacity employing high-surface-area electrode materials (e.g., activated carbons with surface areas of $3000 \text{ m}^2/\text{g}^{-1}$ or higher or carbon aerogels with even higher specific surface area) are called → *supercapacitors* or – in case of even higher volumetric and/or gravimetric capacity – ultracapacitor. As both types of capacitors are essentially based upon the capacitive property of the electrochemical → *double layer* the only distinctive property is the actual capacity of a device; while → *supercapacitor* have typical capacities in the range of a few hundred mF, ultracapacitors have capacities of several F. Because of the operating principle the voltage which might be applied to an ultracapacitor must remain below the decomposition voltage of the electrolyte solution, or of the employed electrodes, typical values are 2.3 to 2.5 V. Depending on the electrode material and the electrolyte solution constituents beyond mere charging/discharging of the double-layer redox processes involving said material may occur, this results in a → *pseudocapacitance* which contributes to the overall capacity of the device. Because the redox processes may proceed at rates significantly different from double-layer charging, the behavior of the device becomes more complicated in terms of charging/discharging times.

Refs.: [i] Delnick FM, Tomkiewicz M (eds) (1996) *Electrochemical capacitors – proceedings volume 95–29*. The Electrochemical Society, Pennington; [ii] Conway BE (1999) *Electrochemical supercapacitors: scientific fundamentals and technological applications*. Springer, New York; [iii] Ashtiani C, Wright R, Hunt G (2006) *J Power Sources* 154:561; [iv] Chu A, Braatz P (2002) *J Power Sources* 112:236

RH

Ultramicroelectrode (UME) — an → *electrode* having a characteristic dimension less than $25 \mu\text{m}$. This characteristic dimension refers to a diameter for a disk, a sphere, a hemisphere, and a cylinder, and a width for a band UME, for example. Conceptually, the lower limit of the characteristic dimension of a UME is about 10 nm, which corresponds to the thickness of the → *double layer* or the size of molecules. Electrodes of such dimensions are sometimes referred to as → *nanoelectrodes* or nanodes. Electrodes with a characteristic dimension ranging from $25 \mu\text{m}$ up to approximately 1 mm are referred to as → *microelectrodes*. Electrodes with dimensions of millimeters, centimeters, or meters have been referred to

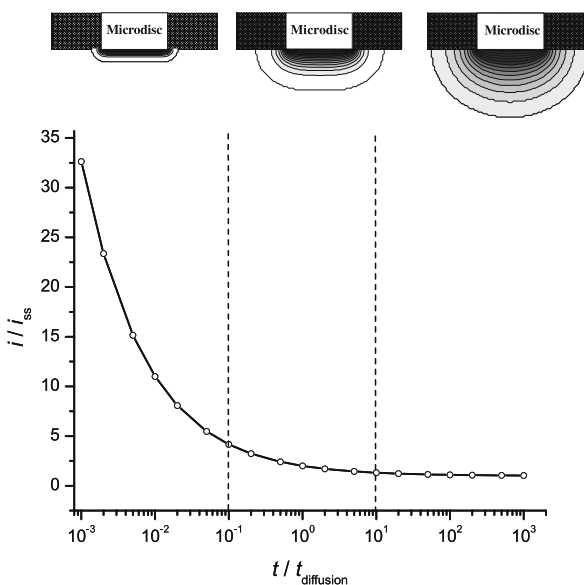

Ultramicroelectrode (UME) — Figure. Diffusion regimes at an inlaid disk UME following a potential step. From left to right: linear diffusion at short times, quasi-hemispherical diffusion at intermediate times, hemispherical diffusion at long times

as “normal”, “conventional”, or macroelectrodes. UMEs are able to readily achieve → *diffusion* layers which are larger than their characteristic dimension and this feature conceptually distinguishes them from micro- and macroelectrodes. UMEs enjoy ease of fabrication and characterization, and theory describing their behavior under a variety of experimental conditions is well developed.

Unlike macroelectrodes which operate under transient, semi-infinite linear diffusion conditions at all times, UMEs can operate in three diffusion regimes as shown in the Figure for an inlaid disk UME following a potential step to a diffusion-limited potential (i.e., the Cottrell experiment). At short times, where the diffusion-layer thickness is small compared to the diameter of the inlaid disc (left), the current follows the → *Cottrell equation* and semi-infinite linear diffusion applies. At long times, where the diffusion-layer thickness is large compared to the diameter of the inlaid disk (right), hemispherical diffusion dominates and the current approaches a steady-state value.

The characteristic diffusion time for any UME geometry where the transition from semi-infinite linear diffusion (transient) to hemispherical or spherical diffusion (steady state) occurs may be given as

$$t_{diffusion} \cong (\text{critical dimension})^2/D$$

where D is the diffusion coefficient of the electroactive species. When the experimental time is much less than $t_{\text{diffusion}}$, the UME behaves as a conventional electrode and all theories developed for electrochemical methods at macroelectrodes apply. When the experimental time is much greater than $t_{\text{diffusion}}$, theories developed for steady-state techniques apply. The transition region between these two limiting regimes involves more complicated theory, offers no advantage, and is generally avoided.

The diffusion-limited steady-state current at UMEs may be written generally as

$$i_{\text{ss}} = nFAm_{\text{O}}C_{\text{O}}^*$$

where n is the number of electrons passed per mole of oxidized species O, F is Faraday's constant, C_{O}^* is the bulk concentration, A is the geometric area, and m_{O} is the mass transfer coefficient. The functional form of m_{O} depends on the UME geometry and is, for example: inlaid disc, $4D/\pi r_{\text{o}}$; hemisphere, D/r_{o} ; sphere, D/r_{o} ; where D is the diffusion coefficient and r_{o} is the radius. The flux of O to a UME by diffusion is $\sim DC_{\text{O}}^*/r_{\text{o}}$ and quite large due to the inverse dependence on the UME radius. Thus, the current at UMEs is relatively immune to convective effects such as stirring in the solution. As shown above, the current at a UME also reaches a steady state in a relatively short time ($\sim r_{\text{o}}^2/D$). For example, a 10- μm radius disk will attain a steady state in a fraction of a second. Because of the small currents, generally pA to nA, that characterize most experiments with UME tips, resistive drops in the solution during the passage of current are generally negligible.

Refs.: [i] Bard AJ, Mirkin MV (eds) (2001) *Scanning electrochemical microscopy*. Marcel Dekker, New York, chap 3; [ii] Bard AJ, Faulkner LR (2001) *Electrochemical methods*, 2nd edn. Wiley, New York, chap 5; [iii] Zoski CG (ed) (2007) *Handbook of electrochemistry*. Elsevier, Amsterdam, chap 6, 11, 12, 19; [iv] Fleischmann M, Pons S, Rolison DR (eds) (1987) *Ultramicroelectrodes*. DataTech Systems, NC

CGZ

Ultrasound — Sound waves [i] of a frequency higher than audible (frequency >18 kHz, or the corresponding wavelength in air 1.8 cm or shorter) are termed ultrasound (as compared to “infrasound” for frequencies <10 Hz). Weak ultrasound is employed in medical imaging and materials characterization. In contrast, power ultrasound can be used to clean surfaces, to mix or disperse reagents, to emulsify two-phase mixtures, or to degas solutions. Chemical reactions useful for waste degradation and polymerization processes occur during the

ultrasonically driven violent collapse of cavitation bubbles [ii]. Strong agitation and interfacial cavitation have been employed in \rightarrow *sono-electrochemistry* to enhance electrochemical processes.

Refs.: [i] Leighton TG (1994) *The acoustic bubble*. Academic Press, London; [ii] Suslick KS (1988) *Ultrasound, its physical, chemical and biological effects*. VCH, Weinheim

FM

Ultrathin layer activation \rightarrow *radiochemical (nuclear) methods in electrochemistry*

Uncertainty — (of measurement) A parameter associated with the result of a measurement which characterizes the degree of dispersion of the data around the mean value of the measurement. See also random \rightarrow *error* [i].

Ref.: [i] IUPAC (1997) *Compendium of chemical terminology*

FG

Uncompensated IR drop \rightarrow IR_{u} (*ohmic potential*) drop

Underpotential deposition (UPD) — Electrochemical deposition of up to one monolayer of one metal onto an electrode of different metal, at potentials higher than those predicted by the \rightarrow *Nernst equation*. Underpotential deposition occurs at sub-monolayer to a maximum of one monolayer. The phenomenon of underpotential deposition reflects the affinity of the foreign metal adatoms to the substrate, as a result of the difference in their \rightarrow *electronegativity*. The extent of the potential deviation from the nernstian one was formulated empirically on grounds of the difference in the \rightarrow *work function* of the two metals, and expressed as $\Delta U_{\text{p}} = \alpha \Delta \Phi$ with $\alpha = 0.5 \text{ V eV}^{-1}$ (ΔU_{p} denotes the difference between the monolayer under-potential deposition voltage as compared with bulk deposition, $\Delta \Phi$ the difference in the work functions of the two metals). Underpotential deposition was explored as a useful method for the production of special catalysts, and as a fine electroanalytical tool for accurate surface area measurement. In a wider sense, e.g., the \rightarrow *adsorption* of \rightarrow *hydrogen* or oxygen on platinum can also be considered UPD. See also \rightarrow *potential*, subentry \rightarrow *underpotential deposition*.

Refs.: [i] Kolb DM, Przasnyski M, Gerischer H (1974) *J Electroanal Chem* 54:25; [ii] Kolb DM (1978) *Physical and electrochemical properties of metal monolayers on metallic substrates*. In: Gerischer H, Tobias CW (eds) *Advances in electrochemistry and electrochemical engineering II*. Wiley, New York, pp 125–271; [iii] Aramata A (1997) *Underpotential deposition on single-crystal metals*. In: Bockris JOM, White RE, Conway DE (eds) *Modern aspects of electrochemistry*. Plenum Press, New York, pp 181–250; [iv] Bard AJ, Faulkner RL (1980) *Electrochemical*

methods, 2nd edn. Wiley, New York, pp 372–374; [v] Ross PN (1998) *The science of electrocatalysis on bimetallic surfaces*. In: Lipkowski J, Ross PN (eds) *Electrocatalysis*. Wiley-VCH, New York, pp 43–74

YG, DA

Undivided cell — Electrochemical cells where all electrodes (two or three) are placed in the same compartment. Undivided cells are typically used for analytical experiments at small or → *microelectrodes* in aqueous solutions when a → *two-electrode system* is applied, or in a → *three-electrode* measurements in nonaqueous media with a (platinum) → *quasireference electrode*. A requirement in the use of an undivided cell is that the reaction products produced at the counter electrode do not reach or perturb the behavior of the working electrode.

JL

Uninterruptible power supply — (UPS) Electronic power supply providing a safe and permanent source of electricity for devices needing a completely stable, uninterrupted supply of electricity (computers, major storage

and backup systems, medical devices, traffic control systems etc.)(i.e. secondary → *battery*). An electronic circuit supervising the supply of ac power with respect to availability and stability is combined with a secondary → *battery* operated in a permanent trickle-charge mode. In case of a loss of ac power supply the → *accumulator* is connected to an electronic alternator (DC–AC-converter) providing electrical power of the same voltage and frequency as the mains supply. The switching process is fast enough in order to avoid data loss or any other damage.

RH

Unpolarizable electrode → *nonpolarizable electrode*

Usanović acid-base theory → *acid-base theory*

UV-photoelectron spectroscopy (UPS) → *surface analytical methods*

UV-Vis spectroscopy → *spectroscopy*

V

Vacancies — are one sort of point → *defects in solids* which are vacant (empty) crystallographic sites in a crystal lattice. The vacancy formation may be associated with numerous factors, including thermodynamic properties of a crystal at a given temperature and total pressure (thermally activated disorder), chemical equilibration with environment, intercalation of impurities or dopant ions in the lattice (doping-induced disorder), interfacial processes, external factors such as radiation and electromagnetic fields, etc. The vacancy → *diffusion* mechanism is observed when → *ions* in the lattice may jump between vacant sites. In this case, the ion → *diffusion coefficient* is proportional to the vacancy concentration (see also → *Nernst–Einstein equation*). As this process can be visualized as vacancy migration, the vacancies may be considered as ionic → *charge carriers*, although the real charge carriers are ions. Important → *solid electrolytes* with the vacancy diffusion mechanism are → *stabilized zirconia*, doped → *cerium dioxide*, → *BIMEVOX*, and numerous → *perovskites*. Vacant sites at the crystal → *surface* and in the near-surface layers affect strongly the → *exchange current density* and catalytic properties.

See also → *ion conductors*.

Refs.: [i] West AR (1984) *Solid state chemistry and its applications*. Wiley, Chichester; [ii] Rickert H (1982) *Electrochemistry of solids. An introduction*. Springer, Berlin

VK

Vacuum spectroscopy → *surface analytical methods*

Valence band — The energy band of a solid is an → *energy* interval with a quasicontinuum distribution of allowed energy levels for electrons. In solid-state physics, from the theoretical point of view, low-lying electron core levels are well described by tight-binding wave functions and are inert for many purposes. Energetically higher lying bands, which are either filled, partially filled or empty, are in this context referred to as valence bands. These valence bands determine the electronic behavior of solids in a variety of circumstances. When related to → *semiconductors*, however, the term valence band denotes the highest fully occupied energy band at $T = 0$. If the temperature is not zero there is a nonvanishing probability that some electrons will be thermally excited from the valence band across the energy gap into the → *conduction band*, leading to unoccupied electron

states, called holes, in the valence band, and hole-type conduction. See also → *semiconductor*.

Refs.: [i] Blakemore JS (1987) *Semiconductor statistics*. Dover, New York; [ii] Ashcroft W, Mermin ND (1976) *Solid state physics*. Saunders College, Philadelphia

IH

Valve metals — Metals that form a compact, electronic insulating passive layer when anodized in aqueous electrolyte, exhibiting asymmetric → *conductivity*: blocking anodic reactions, except at very high voltages. Valve metals include aluminum, → *titanium*, tantalum, zirconium, hafnium, and niobium. Some other metals, such as tin, may exhibit valve-metal properties under specific conditions.

In → *electrochemical cells*, valve metals function generally as a → *cathode*, but not generally as an → *anode* due to the insulating oxide layer that forms on the metal surface under anodic conditions. This oxide is highly resistant to the passage of current, and may serve for corrosion protection. In most cases the oxide passivating films are either amorphous, or composed of very small crystalline domains (with high defect concentration) within an amorphous matrix. The anodic oxide layers can be grown up to 100 nm thick.

Valve metals are used in electronic components, such as tantalum capacitors, microwave field-effect transistors, gate materials, etc.

Refs.: [i] Hassel AW, Diesing D (2002) *Thin Solid Films* 414:296; [ii] Strehlow HH (2003) *Passivity of metals*. In: Alkire RC and Kolb DM (eds) *Advances in electrochemical science and engineering*, vol. 8. Wiley-VCH, Weinheim, pp 271–374; [iii] Kern W, Schuegraf KK (2002) *Deposition technologies and applications: introduction and overview*. In: Seshan K (ed) *Handbook of thin film deposition techniques: principles, methods, equipment and applications*. William Andrew, Noyes, p 19

YG

van der Waals forces — are attractive (or repulsive) short-range forces between → *molecular entities* (or between groups within the same molecular entity) other than those due to bond formation or to the electrostatic interaction of ions or of ionic groups with one another or with neutral molecules. They include: dipole–dipole interactions (orientation interaction, → *Casimir force*), dipole-induced dipole interaction (induction interaction, Debye force), and instantaneously induced dipole-induced dipole forces (dispersion interaction, → *London forces*). All three kinds of van der Waals forces have the same potential dependence on intermolecular distance r , i.e., they are proportional to r^{-7} (usually the distance dependence of the potential energy is given which

is r^{-6}). Generally, the London forces strongly dominate. Typical energy is 0.3–2 kJ mol⁻¹ [i, ii].

Refs.: [i] Hunter RJ (2004) *Foundations of Colloidal Science*, 2nd edn. pp 533 Oxford University Press, Oxford; [ii] Atkins PW (1993) *Physical Chemistry*. Oxford University Press, Oxford, p 763; [iii] Israelachvili J (1992) *Intermolecular and surface forces*, Academic Press, London

WK

van't Hoff, Jacobus Henricus → Hoff, Jacobus Henricus van't

Variance — A parameter used to indicate the → precision of a measurement which is equal to the square of the → standard deviation [i].

Ref.: [i] Skoog D, West D, Holler F, Crouch SR (2003) *Fundamentals of analytical chemistry*, 8th edn. Brooks/Cole, Belmont

FG

Varley cell — This was a variant of the → Daniell cell. See also → zinc, → Zn²⁺/Zn electrodes, → Zn²⁺/Zn(Hg) electrodes, → Zinc-air batteries (cell), and → Leclanché cell.

Ref.: [i] Hauck WP (1883) *Die Galvanischen Batterien, Accumulatoren und Thermosäulen*, 2nd edn. Hartleben's Verlag Wien

FS

V

Velocity (v) — is a vector measure of the rate of change of the position of a point with respect to time. For cartesian space the velocity of a point (x) can be written as $v = dx/dt$ and has units of m s⁻¹ using the SI system. In polar coordinates a two-dimensional velocity can be represented by an angular velocity (ω) and the distance to the origin (r), $v = \omega r$. Velocity is found widely within electrochemical analysis, for example, within hydrodynamic devices such as the rotating disc electrode where the solution velocity may often be approximated analytically [i, ii], permitting, via further analysis, current/voltage characteristics to be calculated.

Refs.: [i] von Karman T (1921) *Z Angew Math Mech* 1:233; [ii] Cochran WG (1934) *Proc Camb Philos Soc Math Phys Sci* 30:345

AF

Verwey–Niessen model — Earliest theoretical model of the → interface between two immiscible electrolyte solutions (ITIES) assuming the existence of a diffuse double layer with one phase containing an excess of the positive space charge and the other phase an equal excess of the negative space charge [i] (Figure). The difference of → inner electric potentials, $\Delta_o^w \phi = \phi^w - \phi^o$, then splits into two components,

$$\Delta_o^w \phi = \phi_2^o - \phi_2^w$$

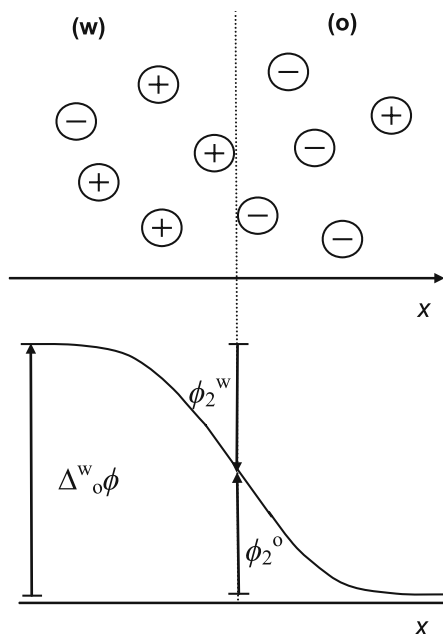

Verwey–Niessen model — Figure

where ϕ_2^w and ϕ_2^o are the potential differences across the space–charge regions on the aqueous and the organic solvent side, respectively. By using the classical theory of → Gouy [ii] and → Chapman [iii] (GC), ϕ_2^w and ϕ_2^o were related to the → surface charge density σ^w and σ^o [i]. Assuming that a symmetric 1:1 electrolyte is present in the phase w and o,

$$\begin{aligned} \sigma^w &= -2A^w \sinh(F\phi_2^w/2RT) \\ &= -\sigma^o = 2A^o \sinh(F\phi_2^o/2RT) \end{aligned}$$

where $A^{w,o} = (2RT\epsilon^{w,o}\epsilon_0 c^{w,o})^{1/2}$, $\epsilon^{w,o}$ and ϵ_0 are the relative dielectric → permittivity and the permittivity of vacuum, respectively, and $c^{w,o}$ are the bulk electrolyte concentrations. By analogy with Stern's modification [iv] of the GC theory, Gavach et al. [v] introduced the concept of an ion-free layer of oriented solvent molecules, which separates the two space–charge regions at ITIES – a modified Verwey–Niessen (MVN) model, while Girault and Schiffrin [vi] proposed that a continuous change in composition from one phase to the other (mixed ion and solvent layer) is a more realistic picture. The model including a mixed dielectric region and ion interpenetration was scrutinized [vii]. The ion distribution predicted by the mean-field theories such as the GC theory was inspected by X-ray reflectivity measurements, and a better agreement with experiment was reached using the potential of mean force from molec-

ular dynamics simulation in the generalized \rightarrow Poisson–Boltzmann equation [viii].

The general thermodynamic approach yields the \rightarrow Gibbs–Lippmann equation (\rightarrow electrocapillary) for the nonpolarizable [v] and ideally polarizable [ix] ITIES. For the interface between the electrolyte solutions of RX in o and SY in o, see also \rightarrow interface between two immiscible electrolyte solutions, this equation has the form [x]

$$-d\gamma(T, p = \text{const}) = \sigma^w dE_{o+}^{w-} + (\Gamma_{R^+}^{w,o} + \Gamma_{RX}^{w,o} + \Gamma_{RY}^{w,o}) d\mu_{RX} + (\Gamma_{Y^-}^{w,o} + \Gamma_{SY}^{w,o} + \Gamma_{RY}^{w,o}) d\mu_{SY}$$

where $\Gamma_i^{w,o}$'s are relative surface excess concentrations including the contributions of the bulk (R^+X^- , S^+Y^-) and interfacial (R^+Y^- , S^+X^-) ion pairs, E_{o+}^{w-} is the potential difference of the cell with the aqueous reference electrode being reversible to anion X^- and the organic reference electrode being reversible to cation S^+ . The surface charge density σ^w

$$\sigma^w = - \left(\frac{\partial \gamma}{\partial E_{o+}^{w-}} \right)_{T,p,\mu} = F(\Gamma_{R^+}^{w,o} - \Gamma_{X^-}^{w,o} + \Gamma_{RY}^{w,o} - \Gamma_{SX}^{w,o}) = F(\Gamma_{Y^-}^{w,o} - \Gamma_{S^+}^{w,o} + \Gamma_{RY}^{w,o} - \Gamma_{SX}^{w,o})$$

sums up the contributions from both the free charge and the charge associated with the adsorption of ion pairs and, hence, it represents the total charge that is necessary to supply so as to maintain the state of the interface when the interfacial area is increased by a unit amount. A related quantity is the \rightarrow differential capacity C ,

$$C = \left(\frac{\partial \sigma^w}{\partial E_{o+}^{w-}} \right)_{T,p,\mu} .$$

Experimentally, the \rightarrow electric double layer at ITIES has been studied mainly by \rightarrow surface tension [x, xi] and differential capacity [xii] measurements. Experimental results and theoretical models were reviewed [xiii].

Refs.: [i] Verwey EJW, Niessen KF (1939) *Philos Mag* 28:435; [ii] Gouy G (1910) *CR Acad Sci* 149:654; [iii] Chapman DL (1913) *Philos Mag* 25:475; [iv] Stern O (1924) *Z Elektrochem* 30:508; [v] Gavach C, Seta P, d'Epenoux B (1977) *J Electroanal Chem* 83:225; [vi] Girault HH, Schiffrin DJ (1983) *J Electroanal Chem* 150:43; [vii] Monroe C, Urbakh M, Kornyshev AA (2005) *J Electroanal Chem* 582:28; [viii] Luo G, Malkova S, Yoon J, Schultz DG, Lin B, Meron M, Benjamin I, Vanýsek P, Schlossman ML (2006) *Science* 13:216; [ix] Kakiuchi T, Senda M (1983) *Bull Chem Soc Jpn* 56:2912; [x] Girault HH, Schiffrin DJ (1984) *J Electroanal Chem* 170:127; [xi] Kakiuchi T, Senda M (1983) *Bull Chem Soc Jpn* 56:1753; [xii] Samec Z, Mareček V, Homolka D (1981) *J Electroanal Chem* 126:121; [xiii] Samec Z (2001) *Capacitance and surface tension*

measurements of liquid–liquid interfaces. In: Volkov AG (ed) *Liquid interfaces in chemical, biological, and pharmaceutical applications*. Marcel Dekker, New York, pp 415–437

ZSam

Vesicles — (i) In cell biology, a vesicle is a small enclosed compartment, separated from the cytosol of a eukaryotic cell by a membrane of fatty acids. Vesicles are responsible for the transport of various compounds across cell membranes by \rightarrow endocytosis and \rightarrow exocytosis.

(ii) In colloid chemistry, a vesicle is an assembly of surfactant molecules, about 0.1–100 μm in diameter, that contains solvent, usually water, both inside and outside. The assembled surfactant may consist of a single bilayer or be formed of multilayers. Good examples of vesicle-forming surfactants are provided by \rightarrow phospholipids. Technologically, man-made vesicles can encapsulate bioactive molecules, hence their increasing use in drug delivery. See also \rightarrow liposomes.

Ref.: [i] Alberts B, Johnson A, Lewis J, Raff M, Roberts K, Walter P (2002) *Molecular biology of the cell*, 4th edn. Taylor & Francis Books, Routledge FS, SF

Vetter, Klaus Jürgen



(July 13, 1916 in Berlin, Germany – Dec. 12, 1974 in Berlin, Germany) Study of chemistry and physics in Göttingen and Berlin; from 1955 professor of physical chemistry at the Free University of Berlin. Cooperation with K. F. Bonhoeffer, \rightarrow Gerischer, and J. W. Schultze, almost 100 publications (fundamentals of electrode kinetics, overpotential, redox reactions, ion transfer, passivity and corrosion, especially of iron), most important is his book [i]:

Ref.: [i] Vetter KJ (1961) *Elektrochemische Kinetik*. Springer, Berlin; Engl ed: Vetter KJ (1967) *Electrochemical kinetics*. Academic Press, New York MML

Vibrating electrode — Vibrational movements of electrodes create agitation effects and therefore result in conditions of hydrodynamic flow (\rightarrow hydrodynamic voltam-

metry, → *rotating disk electrode*, → *sonoelectrochemistry*). Under these conditions enhanced currents due to convection and thinning of the → *Nernst layer* are observed. The effects of vibrating electrodes depend on electrode shape, frequency of vibration, and amplitude. Vibrating electrodes are employed in industrial processes [i] and in electroanalysis [ii].

Refs.: [i] Altaweel AM, Ismail MI (1976) *J Appl Electrochem* 6:559; [ii] Williams DE, Ellis K, Colville A, Dennison SJ, Laguillo G, Larsen J (1997) *J Electroanal Chem* 432:159

FM

Viscosity — A measure of the frictional resistance a fluid offers to an applied shear force under the conditions of → *laminar flow*. According to Newton's law of viscous flow

$$F = \eta A \frac{dv}{dr},$$

the frictional force F is proportional to the area A of the interface and the velocity gradient. The viscosity coefficient η is the proportionality constant. In case of a perfect gas η is related to the properties of the gas according to

$$\eta = \frac{m\bar{v}}{2\sqrt{2}\pi d^2}$$

with m the mass of the flowing molecules, \bar{v} their average velocity, and d the molecular diameter. With incompressible liquids η is given by → *Hagen-Poiseuille's law*

$$\eta = \frac{\pi r^4 \Delta p}{8lv}$$

with r the radius of the tube of length l , v the flow velocity, and Δp the pressure difference between points at the tube spaced at a distance l .

Ref.: [i] Moore WJ (1971) *Physical chemistry*. Longman, London

RH

Viscosity, kinematic — The dynamic viscosity η divided by the density ρ yields the kinematic viscosity $\nu = \eta/\rho$. See → *rotating disc electrode*.

RH

Vitamin K — Fat-soluble vitamin K is a group name for fat-soluble compounds which have in common a methylated naphthoquinone ring structure. Vitamin K is found in nature in two forms – K₁ or phylloquinone is found in plants and vitamin K₂ or menaquinone can be synthesized by many bacteria. Vitamin K₃ (menadione) is a synthetic form of this vitamin. Vitamin K is used

in the body to control blood clotting and is essential for synthesizing the liver protein that controls clotting. Vitamin K is used as a hydrophobic acceptor of electrons in electrochemistry.

Ref.: [i] Volkov AG, Gugeshashvili MI, Mironov AF, Boguslavsky LI (1983) *Bioelectrochem Bioenerg* 10:485

AV

Volcano curves — Semilogarithmic plots representing correlations of the → *electrode reaction rates* (or → *exchange current densities* j_0) and adsorption energies of the reactants, intermediate species, or reaction products for sets of electrode materials. This type of plots was initially proposed in heterogeneous catalysis as obtained for the first time by A. Balandin [i]. Volcano plots for the cathodic → *hydrogen evolution* on various metals induced the most detailed discussion; for this reaction, a clear volcano-like tendency is found for $\log j_0$ versus hydrogen → *adsorption energy*, with the top point for Pt. Qualitatively similar plots were reported for other electrocatalytic reactions [ii]. V. curves are also typical for correlations of the electrode reaction rate and various properties of the electrode materials affecting adsorption enthalpies or interrelated with these quantities. Intuitively, the nature of v. curves can be understood as follows: Low adsorption energies correspond to low surface coverage (θ) with an adsorbed reaction component, and thus correspondingly low reaction rates. For very high adsorption energies, θ is high enough, but the reaction rate is low because of a too strong bonding of the adsorbate to the surface. Actually, one can assume that the reaction rate is proportional (under rough approximation) to $\theta(1 - \theta)$ with a maximum at $\theta = 1/2$. A limiting point in constructing v. curves is the lack of reliable data on adsorption energies under conditions of electrochemical experiments, i.e., when coadsorption with the solvent and electrolyte ions takes place. Another complication arises from a possible change of the reaction mechanism with θ when going from one metal to another [iii]. The reliability of v. curves is also affected by the accuracy and reproducibility of experimental j_0 values and the rates of electrocatalytic processes on solid metals, because of pronounced structural sensitivity [iii]. Sometimes, v. curves present a useful tool for predicting electrocatalytic activities of bi- and multimetallic catalysts. See also → *electrocatalysis*.

Refs.: [i] Balandin A (1958) *Adv Catal* 10:120; [ii] Appleby A (1983) In: Conway B, Bockris JO'M, Yeager E, Kuhn S, White R (eds) *Comprehensive treatise of electrochemistry*, vol. 7. Plenum Press, New York, p 173; [iii] Petrii OA, Tsirlina GA (1994) *Electrochim Acta* 39:1739

OP

Volmer, Max



(May 3, 1885, Hilden, Germany – June 3, 1965, Potsdam, Germany) Volmer began his chemical studies in Marburg in 1905. In 1908 he moved to the Physikalisch-chemisches Institut in Leipzig, which was then under the direction of → *Le Blanc*. It was there that he received his doctorate in 1910. At the outbreak of WWI he was conscripted into the Army, and from 1916–18 he worked at the Institute of → *Nernst* in Berlin as a ‘gas defense officer’. Although his war work was of only temporary importance, the interaction with Nernst had a lasting effect on his scientific thinking. Around the same time Volmer also met Otto Stern (1888–1969). The Stern–Volmer equation of fluorescence intensity was a product of their cooperation. In 1929 he became Professor in Hamburg, and in 1922 Professor at the TH (now the Technical University) of Berlin. During the Nazi period Volmer experienced numerous set-backs (for example, his election to the Prussian Academy of Science was blocked), and after WWII he along with other German scientists was sent to the USSR to work on deuterium production and nuclear waste processing. However, in 1955 he was permitted to return to Germany and became Professor of Physical Chemistry at Humboldt University (East-Berlin), eventually becoming President of the East German Academy of Sciences. Volmer’s most important contributions to physical chemistry concern nucleation and growth of new phases, esp. crystals. In 1921 he published a paper on the mechanism of deposition of molecules on crystal surfaces [i] where he elegantly showed that the deposition rates vary considerably on different crystal faces. A theoretical treatment of nucleation followed in 1926 [ii], and in the same year he published the experimental proofs of surface diffusion [iii]. On the basis of the thermodynamics developed by → *Gibbs*, Volmer derived an equation for the nucleation work, which he clearly understood to consist of two terms, a surface term and a bulk term. In 1928,

Volmer turned his attention to processes at → *nonpolarizable electrodes* [iv], and in 1930 followed the famous publication (together with → *Erdey-Grúz*) on the theory of hydrogen → *overpotential* [v], which today forms the background of phenomenological kinetics of electrochemistry, and which resulted in the famous → *Butler–Volmer equation* that describes the dependence of the electrochemical rate constant on applied overpotential. His major work, “Kinetics of Phase Formation”, was published in 1939 [v]. See also the Volmer reaction (→ *hydrogen*), and the Volmer biography with selected papers [vi].

Refs.: [i] Volmer M, Estermann I (1921) *Z Phys* 7:13; [ii] Volmer M, Weber A (1926) *Z phys Chem* 119:277; [iii] Volmer M, Adhikari G (1926) *Z phys Chem* 119:46; [iv] Erdey-Grúz T, Volmer M (1930) *Z phys Chem* A150:203; [v] Volmer M (1939) *Kinetik der Phasenbildung*. T Steinkopff, Dresden; Engl transl: *Kinetics of phase formation*. Clearinghouse for Federal and Technical Information, ATI No. 81935 [F-TS-7068-RE]; [vi] Volmer M (1983) *Zur Kinetik der Phasenbildung und der Elektrodenreaktionen*. In: Dunsch L (ed) *Ostwalds Klassiker der exakten Naturwissenschaften*, vol. 262. Akadem Verlagsges Geest & Portig, Leipzig

EK, FS

Volmer reaction → *hydrogen*

Volmer–Weber heteroepitaxial metal deposition → *epitaxial metal deposition*, and → *Volmer*.

Volmerian electrode reaction — This term has been used for electrode reactions in which the → *charge transfer coefficient* is constant. Reactions for which the latter is potential dependent were called non-volmerian. According to the → *Marcus theory* there is **generally** a potential dependence of the charge transfer coefficient, however that is usually very small. The terms ‘volmerian’ and ‘non-volmerian’ refer to the classic Butler–Volmer theory (→ *Butler–Volmer equation*) where no potential dependence was assumed. See also → *Volmer*.

Ref.: [i] Bard AJ, Faulkner LR (2001) *Electrochemical methods*, 2nd edn. Wiley, New York, pp 121

FS, SF

Volt — SI-derived measurement unit of the electric → *potential* difference or voltage. Symbol: V (named in honor of the Italian physicist Alessandro → *Volta* (1745–1827)). Definition: 1 volt is the potential difference between two points of a homogeneous, linear conductor of constant temperature, when a current of one ampere converts one watt of power.

$$1 \text{ V} = 1 \text{ W A}^{-1} = \text{J C}^{-1} = \text{m}^2 \text{ kg s}^{-3} \text{ A}^{-1}.$$

Ref.: [i] Cohen ER, Cvitas T, Frey JG, et al (eds) (2006) *IUPAC quantities, units and symbols in physical chemistry*

BM

Ref.: [i] Pancaldi G (2005) *Volta: Science and culture in the age of enlightenment*. Princeton University Press, Philadelphia

EK

Volta, Alessandro Giuseppe Antonio Anastasio



(Feb. 18, 1745, Como, Lombardy, Italy – Mar. 5, 1827, Como, Italy) Volta was educated in Como, and became professor of physics at the Royal School there in 1774. Volta made fundamental studies of electricity [i]. His studies of static electricity in 1775 led him to the invention of the electrophorus, a device used to generate static electricity. In 1776–77 he studied the chemistry of gases and discovered methane. In 1779 he became professor of experimental physics at the University of Pavia, where he worked for almost 40 years. Arguing with → *Galvani* about the mechanism of electricity generation in metal electrodes contacting animal tissue, he discovered that electricity can be generated upon contacting two different metals without need of the tissue. This led him to the construction of the first electrical → *battery* (voltaic pile) that became an important instrument in many electrical studies.

He received the Copley Medal, the highest award from the Royal Society of London in 1794, and Napoleon also honored his invention with a gold medal (1801), named an award after him, and made him a count in 1810.

→ *voltage* (the driving force that moves electric current), and the SI unit of → *electric potential*, → *electromotive force*: volt (with a symbol V) as well as the difference of the outer potential of phases (→ *Volta potential difference*) were named after him. His name appears also regarding electrochemical techniques (e.g., → *voltammetry*) and representations (e.g., → *voltammogram*). The Volta Crater on the Moon is also named in his honor, and his portrait was on the Italian 10,000 lira banknote before the euro era. The Tempio Voltiano near Lake Como is a museum devoted to his life and achievements. See also → *Volta pile*.

Volta pile — On March 20, 1800, Alessandro → *Volta*, then professor of the University of Pavia sent a letter in French from Como, Lombardy to Sir Joseph Banks (1743–1820) the president of the Royal Society of London, for publication. He described a device – that he called “artificial electrical organ” referring to the natural electrical organ of the torpedo or electric eel – producing “perpetual” electrical motion. The paper was read at the Society on 26 June and published in the September issue of the *Philosophical Transactions*. The whole paper appeared in English in the *Philosophical Magazine* the same year [i, ii].

The importance of Volta’s invention can scarcely be overestimated. For the first time, steady currents of electricity could be produced readily.

Volta described two versions of the → *battery*, the “column” and the “chain of cups” (Fig. 1). The Volta pile was a great success immediately also for that because everybody could build easily such a device by using disks

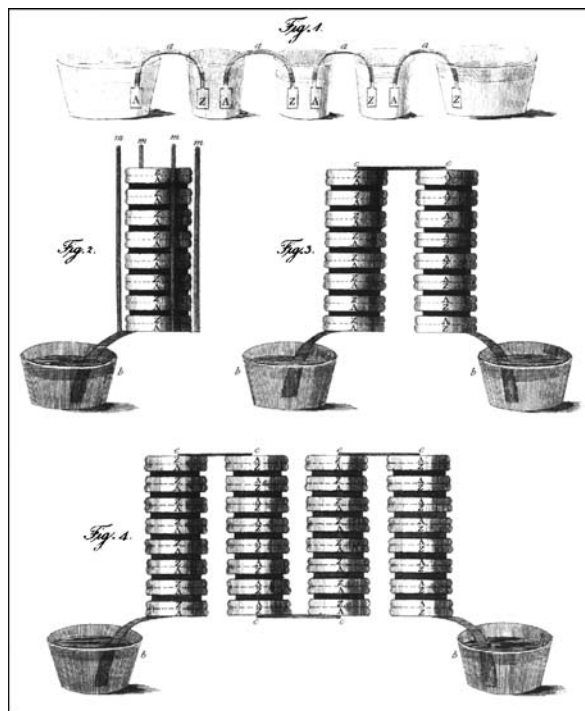

Volta pile — **Figure 1.** Drawings of Volta piles (Figs. 2–4) and the chain of cups arrangement (Fig. 1) from the original paper of Volta [i]. A is Ag or Cu, Z is Zn or Sn



Volta pile — Figure 2. A Volta pile

of two different metals, e.g., silver or copper or brass with tin or zinc and a moistened pasteboard or other spongy matter capable of retaining a great deal of water between them (Fig. 2).

The Volta pile was used in the same year to carry out \rightarrow *electrolysis* and it helped to discover a wide range of new phenomena during the next decades. The descendants of the Volta pile are the batteries that are still widely used in today's everyday life, in science and technology, and even in spaceships. Volta's invention changed the way of life on our planet.

Refs.: [i] Volta A (1800) *Philos Trans R Soc London* vol 2, plate XVII 403; *Philos Mag* 7:289; [ii] Volta A (1800) *On the electricity excited by*

the mere contact of conducting substances of different kinds. Bicentenary Edition in French, English, German, and Italian, Univ. Pavia, Hoepli, 1999

GI

Volta potential difference \rightarrow *potential*

Voltadeflectometric peak — A maximum or a minimum of the deflection signal developed in a \rightarrow *cyclic voltadeflectogram*. The peak is related to the maximal concentration gradients of soluble species at the probe beam position [i].

Ref.: [i] Barbero CA (2005) *Phys Chem Chem Phys* 7:1885

FG

Voltage — Voltage is the measure of the difference in electric \rightarrow *potential* between two chosen points of space. In field theory it reflects the averaged value of electric field parallel to the line connecting the points and present on the line itself. In common understanding, voltage is a difference of electric potential between two points of an electric circuit. Then it gives the driving force for charges to move along the circuit and reflects the circuit current (\rightarrow *Ohm's law*).

MD

Voltage compliance \rightarrow *compliance limits*

Voltage followers \rightarrow *operational amplifier*

Voltage gated ion channel \rightarrow *ion transport through membranes and ion channels*

Voltage of an electrochemical cell \rightarrow *electrochemical cell*, subentry \rightarrow *voltage of an electrochemical cell*

Voltage source — It is a device or system forcing \rightarrow *potential* difference between two points in space; as a result it produces \rightarrow *electromotive force*. In electric circuits voltage sources give rise to \rightarrow *current*. An ideal voltage source should keep the original output voltage no matter what current it will produce. Real voltage sources because of internal limitation give the demanded voltage to a certain extension of current. Commonly used voltage sources are: \rightarrow *batteries*, current rectifiers, and \rightarrow *potentiostats*, which are the closest to ideal voltage sources.

MD

Voltmeter \rightarrow *coulometer*

Voltammetry — Measurement of \rightarrow *current* as a function of a controlled \rightarrow *electrode potential* and time. The

resultant current–voltage (or current–time or current–voltage–time) display is commonly referred to as the “voltammogram” [i–ii]. The term “voltammetry” was coined by → *Laitinen* and → *Kolthoff* [iii–iv]. The protocol for potential control may vary, leading to a number of different techniques each with their common names. See, for example → *AC voltammetry*, → *pulse voltammetry*, → *cyclic voltammetry*, → *stair case voltammetry*, → *faradaic rectification voltammetry*, → *Fourier transform voltammetry*, → *hydrodynamic voltammetry*, → *electrochemical impedance spectroscopy*, → *linear scan voltammetry*, interdigitated array voltammetry, → *microelectrode voltammetry*, → *polarography*, → *rotating disk voltammetry*, → *scanning electrochemical microscopy* (SECM), → *square-wave voltammetry*, → *stripping voltammetry*, → *ultramicroelectrode voltammetry*. The objectives of a voltammetric experiment also vary, ranging from analytical measurements designed to determine the concentration of an analyte to measurements designed to elucidate complex mechanisms and the values of the associated thermodynamic and kinetic (homogeneous and heterogeneous) parameters [i].

Refs.: [i] Bard AJ, Faulkner LR (2001) *Electrochemical methods*, 2nd edn. Wiley, New York; [ii] Oldham KB, Myland JC (1994) *Fundamentals of electrochemical science*. Academic Press, San Diego; [iii] Laitinen HA, Kolthoff IM (1941) *J Phys Chem* 45:1061; [iv] Laitinen HA, Kolthoff IM (1941) *J Phys Chem* 45:1079

MD

Voltammetry, cyclic → *cyclic voltammetry*

Voltammetry of immobilized microparticles (VIM) — Technique for studying the → *electrochemistry* of solid particles, esp. microparticles, that are insoluble (or very poorly soluble) in a certain → *electrolyte* solution. The particles are mechanically transferred to the surface of a suitable electrode. That electrode should have a rather soft surface as to allow mechanical embedding of the particles in the electrode surface. Very well suited are → *paraffin-impregnated graphite electrodes*, however, other → *graphite electrodes* also can be used. The transfer of particles to the electrode surface can be accomplished by placing the sample powder on a glass plate, on a glazed tile, or on filter paper and rubbing the electrode on the sample spot. Although the amount of transferred sample cannot be controlled exactly, it can be determined in many cases from the electrochemical measurements (integration of current versus time or potential curves), and the characteristic potentials of voltammetric measurements can be evaluated in a quantitative way. The technique was initially developed to analyze the

quantitative composition of alloys [i] where the transfer of alloy traces to the electrode was achieved by rubbing the electrode surface on a clean alloy surface (→ *abrasive stripping voltammetry*). Later the technique was employed in studies of various materials, ranging from alloys, minerals, inorganic powder mixtures, metal complexes, oxides etc. to metal organic compounds and organic dyes. The technique found application for analytical studies and basic electrochemical research of reactions of solid particles [ii, iii].

Refs.: [i] Scholz F, Nitschke L, Henrion G (1989) *Naturwissenschaften* 76:71; [ii] Scholz F, Meyer B (1998) *Voltammetry of solid microparticles immobilized on electrode surfaces*. In: Bard AJ, Rubinstein I (eds) *Electroanalytical chemistry*, vol. 20. Marcel Dekker, New York; [iii] Scholz F, Schröder U, Gulaboski R (2005) *Electrochemistry of immobilized particles and droplets*. Springer, Berlin

FS

Voltammogram — A plot of → *current* versus → *potential* as measured in → *voltammetry*. When voltammetry is performed using a → *dropping mercury electrode*, i.e., → *polarography*, the voltammogram is traditionally termed → *polarogram*.

FS

Voltfluorometry — may also be called volt-fluorimetry, is a technique to study the → *ion transfer at liquid–liquid interfaces* driven by the change in the phase-boundary potential (→ *potential*, subentry → *surface electric potential*) as a change in fluorescence intensity [i]. The excitation light is introduced from the organic solvent phase, e.g., 1,2-dichloroethane, so that the condition of the total internal reflection at the liquid–liquid interface is satisfied. The change in the fluorescence intensity in the organic solvent phase is proportional to the total quantity of fluorescent ions transferred from the aqueous phase to the organic phase, and, hence, a fluorescence intensity vs. potential curve is essentially isomorphic to a → *coulometry* response. The sensitivity of voltfluorometry is, at least, 1000 times higher than that of coulometry or → *voltammetry*; a voltfluorogram for the transfer of 2 nanomolar fluorescent ions can be detected [ii]. The method can also be applied to the transfer of nonfluorescent ions such as alkali and alkaline earth metal ions if a fluorescent → *ionophore* is present in the organic phase [iii]. The adsorption of transferring ions at the interface is sensitively detected by the voltfluorometry technique with ac modulation of the applied voltage [iv].

Refs.: [i] Kakiuchi T, Takasu Y, Senda M (1992) *Anal Chem* 64:3096; [ii] Kakiuchi T, Takasu Y (1994) *Anal Chem* 66:1853; [iii] Kakiuchi T,

Ono K, Takasu Y, Bourson J, Valeur B (1998) *Anal Chem* 70:4152; [iv] Nishi N, Izawa K, Yamamoto M, Kakiuchi T (2001) *J Phys Chem B* 105:8162

Volumetric energy density → energy density

Volumetric titrimetry — A → titration method in which the volume of → titrant that is added to the → titrand is measured [i].

Ref.: [i] Harris D (2002) *Quantitative chemical analysis*. WH Freeman, New York

Volumetry → volumetric titrimetry

von Neumann boundary condition — The von Neumann boundary condition specifies the derivative of a function at a surface or interface. In electrochemical systems that function is commonly the derivative, $(dc/dx)_{x=0}$, of a concentration, c , of a redox species at an electrode surface and that is directly related to the current density, j , by: $j = \pm nFD(dc/dx)_{x=0}$ where n is the number of electrons transferred per mole, F is Faraday's constant and D is the diffusion coefficient. With the technique of → chronopotentiometry the current and therefore $(dc/dx)_{x=0}$ is defined thereby establishing the von Neumann boundary condition.

VYCOR®-Glass — Vycor® is the registered trademark of Corning, Inc. for porous glasses having nearly the same properties like fused silica or fused quartz. Additionally, they exhibit higher heat shock resistance, greater re-

sistance to deformation, a resistance towards acids and bases, an affinity for moisture ("thirsty glasses"), interesting electric properties and a high transmission in the visible range. They are prepared by a process discovered by Hood and Nordberg [i]. A glass with a high fraction of B_2O_3 is melted in a conventional manner. During the cooling process and heat treatment, two phases are produced, one phase being rich in SiO_2 and insoluble, the other phase being rich in B_2O_3 . The latter one is readily soluble in acids. By removing soluble constituents in hot dilute acid solutions, a porous silica structure is left (around 96% SiO_2). The pore distribution can be controlled by the composition of the molten glass and the heat treatment, and it can be very narrow, resulting in glasses known as controlled pore glass (GPC) [ii]. Porous glasses can be used in a wide range of applications as optical windows, heat-resistant glasses, fritted glassware, sight glasses, thermocouple protecting tubes, and others. In electrochemistry, small discs of Vycor® glass are suitable for use as frits for → reference electrodes or as diaphragms of → salt bridges. Once the porous Vycor, produced by acid etching is heated and fused, it is no longer porous and approaches the properties of quartz.

Refs.: [i] Hood HP, Nordberg ME (1938) *Treated borosilicate glass*, US 2,106,744; [ii] a) Haller W (1965) *Nature* 206:693, b) Haller W (1983) *Application of pore glass in solid phase biochemistry*. In: Scouten WH (ed) *Solid phase biochemistry*. Wiley, New York, pp 535–597; [iii] <http://www.corning.com/lightingmaterials/products/vycor.html>; [iv] Elmer TH (1991) *Porous and reconstructed glasses*. In: *Engineered materials handbook*, vol. 4. ASM International, pp 427–432; [v] Janowski F, Enke D (2002) *Porous glasses*. In: Schüth F, Sing KSW, Weitkamp J (eds) *Handbook of porous solids*. Wiley-VCH, Weinheim, pp 1432–1542

TK

FG

SWF

HK

W

Wadsley defects → *defects in solids*

Wagner Carl

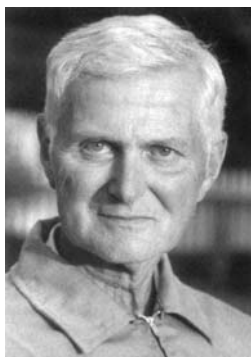

(Reproduced from [ix])

(May 25, 1901, Leipzig, Germany – Dec. 10, 1976, Göttingen, Germany) Wagner studied chemistry at the Universities of Munich and Leipzig and obtained his Ph.D. from Leipzig University where he worked under → *LeBlanc*. From 1924–27 he was scientific assistant at the Pharmaceutical Institute of the University of Munich. In 1927 he became Privatdozent for Applied Chemistry in Munich. From 1927–28 he was at the University of Berlin, from 1928–33 Privatdozent at the University of Jena, where he became extraordinary Professor in 1933. From 1933–34 he was in Hamburg, and from 1934–40 extraordinary Professor of Physical Chemistry at the Technische Hochschule Darmstadt. There he worked as full Professor from 1940–45. From 1945–49 he was Scientific Advisor at Suboffice Rocket, Fort Bliss, Texas, USA. From 1950 to 1955 he was Visiting Professor at MIT, USA, from 1955–58 Professor of Metallurgy at MIT, and from 1958–66 Director at the Max-Planck-Institute of Physical Chemistry, Göttingen, Germany [i]. Carl Wagner is one of the founders of → *solid-state electrochemistry*, and his contributions to solid state chemistry and → *corrosion* are fundamental, both with respect to thermodynamics and kinetics (transport processes and reaction rates). Together with → *Schottky* he led the basis of the thermodynamic treatment of → *defects in solids* [ii, iii], he explained the formation of double salts (e.g., spinells) [iv], explained the tarnishing of metals with the help of defect theory [v], and he pioneered the understanding of corrosion in terms of → *mixed potential* formation [vi]. With the help of defect theory he

was able to explain the conduction mechanism that is operative in the → *Nernst lamp* [vii]. He contributed to many other fields of research, e.g., heat conduction. At the end of his life Wagner published a very interesting philosophical book about the methods of scientific and technical research [viii]. See also the following entries.

Refs.: [i] Schmalzried H (2002) *Bunsenmagazin* 4(2):3; [ii] Wagner C, Schottky W (1930) *Z phys Chem* B11:163; [iii] Schottky W, Ulich H, Wagner C (1929) *Thermodynamik*. Springer, Berlin; [iv] Wagner C (1936) *Z phys Chem* B34:309; [v] Wagner C (1936) *Z phys Chem* B32:447; [vi] Wagner C, Traud W (1938) *Z Elektrochem* 44:391; [vii] Wagner C (1943) *Naturwiss* 31:265; [viii] Wagner C (1974) *Methoden der naturwissenschaftlichen und technischen Forschung*. B.I.-Wissenschaftsverlag, Mannheim; [ix] Martin M (2002) *Bunsenmagazin* 4(2):8

FS

Wagner enhancement factor — describes usually the relationships between the classical → *diffusion coefficient* (→ *self-diffusion* coefficient) of charged species *i* and the ambipolar → *diffusion* coefficient. The latter quantity is the proportionality coefficient between the → *concentration* gradient and the → *steady-state* flux of these species under zero-current conditions, when the → *charge transfer* is compensated by the fluxes of other species (→ *electrons* or other sort(s) of → *ions*). The enhancement factors show an increasing diffusion rate with respect to that expected from a mechanistic use of → *Fick's laws*, due to an internal → *electrical field* accelerating transfer of less mobile species [i, ii].

In a system with two → *charge carriers* (*i* and *s*), this relationship can be expressed using the → *transport numbers* (*t*), → *activities* (*a*), concentrations (*c*) and self-diffusion coefficients (*D*) [iii]

$$\frac{\tilde{D}_{is}}{D_i} = t_i \frac{D_s}{D_i} \frac{\partial \ln a_s}{\partial \ln c_s} + t_s \frac{\partial \ln a_i}{\partial \ln c_i}$$

where \tilde{D}_{is} is the ambipolar diffusion coefficient. See also → *Wagner factor*.

When the transport of ionic species $B^{z\pm}$ is charge-compensated by the transfer of electronic carriers (*e*) [ii, iii]

$$\frac{\tilde{D}_{B^{z\pm}e}}{D_{B^{z\pm}}} = t_e \frac{\partial \ln a_B}{\partial \ln c_{B^{z\pm}}}$$

with t_e being the electron → *transference number*. See also → *electronic defects* and → *electrolytic permeability*.

Sometimes, this term is also used for analysis of relationships between the macroscopic diffusion coefficients

(predicted by Fick's laws from the total concentration gradient) and microscopic diffusion coefficients, taking into account the transport via and occupation of particular crystallographic positions [iv]. See also: → *defects in solids*, → *diffusion: determination in solids*.

Refs.: [i] Wagner C (1936) *Z phys Chem B* 32:447; [ii] Chebotin VN (1989) *Chemical diffusion in solids*. Nauka, Moscow; [iii] Yokota I (1961) *J Phys Soc Jap* 16:2213; [iv] Wagner C (1937) *Z phys Chem B* 38:325

VK

Wagner equation — denotes usually one of two equations derived by → *Wagner* for the flux of charged species $B^{z\pm}$ under an → *electrochemical potential gradient*, and for the → *electromotive force* of a → *galvanic cell* with a mixed ionic–electronic → *conductor* [i–v]:

$$J_{B^{z\pm}} = -\frac{\chi_{B^{z\pm}}}{(zF)^2} [\nabla\mu_{B^{z\pm}} + (zF)\nabla\varphi]$$

$$E = -\frac{1}{zF\nu_B} \int_{\mu_B'}^{\mu_B''} (1 - t_e) d\mu_B$$

where $\chi_{B^{z\pm}}$ is the partial → *conductivity* of these species, t_e is the electron → *transport number*, and μ_B' and μ_B'' are the → *chemical potentials* of neutral component B at the cell → *electrodes*.

The first equation shows that the flux of → *charge carriers* in an electrochemical system is proportional to the partial conductivity and thermodynamic driving force, namely the electrochemical potential gradient (see → *Onsager equation*). When the → *chemical potential* of $B^{z\pm}$ particles is constant, this equation transforms into → *Ohm's law*. When the → *electrical potential* is constant, this equation may be transformed into the first → *Fick's law* using the → *Nernst–Einstein equation*.

The first equation can be written in a more generalized form accounting for the temperature gradient:

$$J_{B^{z\pm}} = -\frac{\chi_{B^{z\pm}}}{(zF)^2} \left[T\nabla \left(\frac{\mu_{B^{z\pm}}}{T} \right) + (zF)\nabla\varphi + \frac{u_{B^{z\pm}}^*}{T} \nabla T \right]$$

where $u_{B^{z\pm}}^*$ is the transported heat of $B^{z\pm}$ species.

An important form of the second formula, which is also denoted as the Wagner equation, can be obtained by integration:

$$E = (1 - \bar{t}_e) E_T$$

where E_T is the theoretical Nernst emf (→ *electromotive force*), the transport number is averaged for a given chemical potential range, and electrode → *polarization*

is neglected. These equations show that non-negligible electronic conductivity ($t_e > 0$) leads to deviations from the → *Nernst equation* and, thus, may decrease the maximum possible work output of an electrochemical system due to energy dissipation caused by internal short-circuiting (see also → *Gibbs energy*, → *solid oxide fuel cells*, → *short-circuit current*, → *oxygen sensor*, and → *electrolytic domain*).

Sometimes the relationship between the rate of the parabolic metal-oxidation process (dn_{ox}/dt), limited by oxygen transport through a dense oxide film, is also called the Wagner equation [vi]:

$$\frac{dn_{\text{ox}}}{dt} = \left[\frac{1}{8\nu F^2} \int_{\mu_{\text{O}_2}'}^{\mu_{\text{O}_2}''} \chi (1 - t_e) t_e d\mu_{\text{O}_2} \right] \frac{1}{\Delta x} = k_{\text{ox}} \frac{1}{\Delta x}$$

where k_{ox} is the parabolic rate constant, and Δx is the thickness of oxide layer.

Refs.: [i] Wagner C (1930) *Z phys Chem B* 11:139; [ii] Wagner C (1933) *Z phys Chem B* 21:25; [iii] Wagner C (1936) *Z phys Chem B* 32:447; [iv] Wagner C (1966) *The electromotive force of galvanic cells involving phases of locally variable composition*. In: Delahay P, Tobias CW (eds) *Advances in electrochemistry and electrochemical engineering*. Wiley Interscience, New York; [v] Wagner C (1972) *Prog Solid State Chem* 7:1; [vi] Kofstad P (1972) *Nonstoichiometry, diffusion and electrical conductivity of binary metal oxides*. Wiley Interscience, New York

VK

Wagner factor — or thermodynamic factor, denotes usually the → *concentration derivative* of → *activity* or → *chemical potential* of a component of an electrochemical system. This factor is necessary to describe the → *diffusion* in nonideal systems, where the → *activity coefficients* are not equal to unity, via → *Fick's laws*. In such cases, the thermodynamic factor is understood as the proportionality coefficient between the self-diffusion coefficient D_B of species B and the real → *diffusion coefficient*, equal to the ratio of the flux and concentration gradient of these species (chemical diffusion coefficient \bar{D}_B):

$$\frac{\partial \ln a_B}{\partial \ln c_B} = \frac{\bar{D}_B}{D_B}$$

Another important case relates to ambipolar → *diffusion*, when a flux of neutral species is driven by a chemical potential gradient. In this case, the thermodynamic factor is usually written in similar form (e.g., $\partial\mu_B/\partial c_B$ or $\partial \ln a_B/\partial \ln c_B$), and may comprise additional multipliers depending on particular formulae; the concentration

may correspond to either neutral or charged species, whilst the chemical potential and activity correspond to the neutral particles. See also → *ambipolar conductivity*.

Using the symbols adopted in this Dictionary, one of the first formulations [i] can be written as

$$\frac{1}{RT} \cdot \frac{\partial \mu_B}{\partial \ln \tilde{c}}$$

where μ_B is the chemical potential of neutral species B, and \tilde{c} is the excess concentration of the corresponding ionic species.

See also → *Wagner equation*.

Refs.: [i] Wagner C (1930) *Z phys Chem B* 11:139; [ii] Kofstad P (1972) *Nonstoichiometry, diffusion and electrical conductivity of binary metal oxides*. Wiley-Interscience, New York; [iii] Rickert H (1982) *Electrochemistry of solids. An introduction*. Springer, Berlin; [iv] Chebotin VN (1989) *Chemical diffusion in solids*. Nauka, Moscow

VK

Wagner number (Wa) — is the dimensionless parameter describing the so-called secondary → *current* distribution at an electrode|electrolyte interface (→ *electrode*, → *electrolyte*, → *interface*) under the conditions when → *overpotential* cannot be neglected, but the → *concentration* polarization is negligible [i]. This number is defined as

$$Wa = \frac{\chi}{L} \frac{d\eta}{dj}$$

where χ is the electrolyte → *conductivity*, and L is the characteristic length of the electrochemical system, such as the radius of a disk electrode. The physical meaning of the Wagner number relates to the ratio between the activation → *resistance* and → *ohmic resistance*.

For → *electroplating* systems [ii], the Wagner number determines the → *throwing power* (the ability of a uniform metal → *deposition* upon a → *cathode* of irregular shape), characterizing the → *current density* equalization due to activation overpotential. In general, decreasing Wagner numbers lead to a less uniform current distribution.

See also → *Wagner*, → *Wagner theory*.

Refs.: [i] IUPAC compendium of chemical terminology: *Nomenclature for transport phenomena in electrolytic systems* (PAC, 1981, 53, 1827). Electronic version: <http://www.iupac.org/goldbook/C01456.pdf>; [ii] Paunovic M, Schlesinger M (1998) *Fundamentals of electrochemical deposition*. Wiley, New York

VK

Wagner theory — denotes usually a great theoretical approach developed by → *Wagner* in the fields of solid-

state electrochemistry, physical chemistry, and physics. The ideas proposed by Wagner constitute a background for the present understanding of many transport, interfacial, and thermodynamic phenomena in solids, particularly in solid-state electrochemical devices such as → *fuel cells*, → *batteries*, → *sensors*, and → *membranes*. Wagner's major contributions in the field of electrochemistry include, but are not limited to, the following areas:

- Analysis of mechanisms of the defect formation, thermodynamics, interaction, association and → *diffusion* in solid materials, validated by deep experimental studies centered on numerous particular cases, including → *solid electrolytes* such as → *stabilized zirconia* (see also → *defects in solids*, → *vacancies*, → *electrolytic domain*, → *electronic defects*, → *doping*).
- Concepts of local equilibrium and charged particle motion under → *electrochemical potential* gradients, and the description of high-temperature → *corrosion* processes, → *ambipolar conductivity*, and diffusion-controlled reactions (see also → *chemical potential*, → *Wagner equation*, → *Wagner factor*, and → *Wagner enhancement factor*).
- Approaches for the description of interfacial processes involving various solid materials, particularly → *ion conductors*, and the theoretical background for the determination of minor contributions to the total conductivity of solids. These achievements made it possible to develop the measurement methods, which today have principal importance for the field of solid-state electrochemistry (see also → *diffusion: determination in solids* and → *Hebb–Wagner method*).

Refs.: [i] Schottky W, Uhlich H, Wagner C (1929) *Thermodynamik*. Springer, Berlin; [ii] Wagner C (1930) *Z phys Chem B* 11:139; [iii] Dünwald H, Wagner C (1933) *Z phys Chem B* 17:467; [iv] Wagner C (1933) *Z phys Chem B* 21:25; [v] Wagner C (1936) *Z phys Chem B* 32:447; [vi] Wagner C, Hantelmann P (1950) *J phys Chem* 54:426; [vii] Wagner C (1956) *Z Elektrochem* 60:4; [viii] Kobayashi H, Wagner C (1957) *J Chem Phys* 26:1610; [ix] Kiuujola K, Wagner C (1957) *J Electrochem Soc* 104:379; [x] Wagner C (1961) *Z Elektrochem* 65:581; [xi] Wagner C (1966) *The electromotive force of galvanic cells involving phases of locally variable composition*. In: Delahay P, Tobias CW (eds) *Advances in electrochemistry and electrochemical engineering*. Wiley-Interscience, New York; [xii] Wagner C (1972) *Prog Solid State Chem* 7:1; [xiii] Wagner C (1975) *Prog Solid State Chem* 10:3; [xiv] Wagner C (1977) *Ann Rev Mater Sci* 7:1

VK

Walden, Paul



(University Archive Rostock, portrait collection)

(July 26, Gregorian Calendar/July 14, Julian Calendar, 1863, Rosenbeck near Riga, at that time Livonia, a province of the Russian Empire, now Latvia – Jan. 22, 1957, Gammertingen near Tübingen, Germany) Studied chemistry in Riga from 1882–88, and 1890–91. Ph.D. with → Ostwald, F.W. in 1891. From 1894–1919 Professor at the Polytechnicum in Riga. The result of his first scientific study is the rule referred to as → Walden's rule (or Ostwald–Walden rule). In 1899 he was awarded the “Dr. of chemistry” of St. Petersburg University; 1919–1934 Professor of Chemistry in Rostock, Germany. In 1895/96 Walden discovered the reversal reaction bearing now his name (Walden's reversal) in organic chemistry. Walden studied nonaqueous electrolyte solutions extensively [i–ii].

Refs.: [i] Walden P (1924) *Elektrochemie nichtwässriger Lösungen*. J Ambrosius Barth, Leipzig; [ii] Walden P (1923) *Molekulargrößen von Elektrolyten in nichtwässrigen Lösungsmitteln*. Steinkopf, Dresden

FS

Walden's rule — This empirical rule states that the product of the equivalent → conductivity and the → viscosity of the solvent for a particular electrolyte at a given temperature is a constant. Its rational explanation is based on the → Stokes–Einstein equation that connects the → diffusion coefficient and the viscosity of the medium, and the → Nernst–Einstein equation that relates the diffusion coefficient to the equivalent conductivity. Hence, the product of the equivalent conductivity and viscosity is inversely proportional to the radius of the moving entity in conductance. As a first approximation, Walden's rule applies to organic → solvents if the radius of solvated ions in various media is not significantly different.

See also → Walden.

Ref.: [i] Bockris JO'M, Reddy AKN (1998) *Modern electrochemistry*, vol. 1, 2nd edn. Plenum Press, New York, p 461

MLo

Walker cell — This was a → Sand battery where the copper electrode is replaced by a graphite or platinized graphite electrode.

Ref.: [i] Hauck WP (1883) *Die Galvanischen Batterien, Accumulatoren und Thermosäulen*, 2nd edn. Hartleben's Verlag, Wien

FS

Wall-jet electrode — An electrochemical cell design wherein a streaming electrolyte solution impinges vertically onto an electrode embedded into the cell wall:

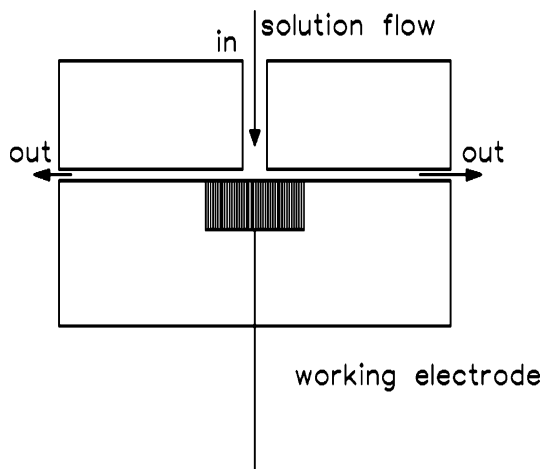

Wall-jet electrode — Figure

The wall jet electrode is employed in electrochemical detectors; the diffusion-limited current is

$$I = 0.898nFc_0D^{2/3}\nu^{-5/12}a^{-1/2}A^{3/8}U^{3/4}$$

with c_0 the concentration of the species to be determined, ν the kinematic → viscosity, a the diameter of the inlet, A the electrode area, and U the average volume flow rate.

Ref.: [i] Wang J (1994) *Analytical electrochemistry*. VCH, New York

RH

Wall-tube electrode → hydrodynamic electrodes

Warburg impedance → impedance

Water — The structure of the water molecule is tetrahedral with → protons in two, and the lone pair electrons in the other two apexes. The O–H bond length is 95.7 pm, the O–H bond energy is 450 kJ mol⁻¹, and the H–O–H angle is 104.5°. The molecule is polarized, with the → dipole moment $\mu = 1.83$ D, where D =

3.33564×10^{-30} C cm. In the solid state (ice) each \rightarrow oxygen atom is surrounded by four \rightarrow hydrogen atoms. Adjacent H_2O molecules are associated by \rightarrow hydrogen bonds. The strength of the hydrogen bond is about twenty times smaller than the strength of a covalent bond and the length of the hydrogen bond is 0.17 nm. Crystalline water, i.e., ice has a honeycomb structure with hexagonal channels. By melting, this hydrogen-bonded lattice is partly destroyed and the average distance between water molecules decreases. For this reason the density of liquid water at 0°C is higher than the density of ice and water has its maximum density at 3.98°C . In the liquid state the water molecule is transiently joined to four others in a short-lived assembly known as a “flickering cluster”. At room temperature water is a polar and \rightarrow amphiprotic liquid. It undergoes \rightarrow autoprotolysis $2\text{H}_2\text{O} \rightleftharpoons \text{H}_3\text{O}^+ + \text{OH}^-$, with the equilibrium constant $a_{\text{H}_3\text{O}^+} a_{\text{OH}^-} = 1.00 \times 10^{-14}$ at 25°C . The hydronium ion H_3O^+ is the key species in the transfer of protons between molecules in aqueous acid-base chemistry (\rightarrow acid-base theories). The \rightarrow mobility of \rightarrow protons in the \rightarrow electric field is enhanced by the formation of protonated water clusters, the smallest of which is H_5O_2^+ , and by a small barrier to proton transfer from one water

molecule to another (see also \rightarrow Eigen complex, \rightarrow Grotthuss mechanism, \rightarrow prototropic charge transport, and \rightarrow Zundel complex). By appearance, water is a clear colorless, odorless, tasteless liquid. Its physical properties are listed in the Table. Water is very good \rightarrow solvent for inorganic salts, mineral acids and bases, and compounds that are capable of forming hydrogen bonds, such as alcohols, phenols, ammonia, amines, amides, and carboxylic acids. Also, water dissolves neutral and acidic gases, such as noble gases, N_2 , O_2 , HCl , and H_2S , and hydrophobic organic compounds (\rightarrow iceberg structure, \rightarrow solvation). Gaseous oxides react with water giving dissolved acids (e.g.: $\text{SO}_2 + 2\text{H}_2\text{O} \rightarrow \text{HSO}_3^- + \text{H}_3\text{O}^+$). Some basic oxides are dissolved giving hydroxyl ions (e.g., $\text{Na}_2\text{O} + \text{H}_2\text{O} \rightarrow 2\text{Na}^+ + 2\text{OH}^-$). \rightarrow Redox reactions of water include the \rightarrow oxidations of the IA group metals (e.g., $2\text{Na} + 2\text{H}_2\text{O} \rightarrow 2\text{Na}^+ + 2\text{OH}^- + \text{H}_2$) and the metal hydrides (e.g., $\text{CaH}_2 + 2\text{H}_2\text{O} \rightarrow \text{Ca}^{2+} + 2\text{OH}^- + 2\text{H}_2$). \rightarrow Electrode reactions of water are the \rightarrow reduction of hydrogen ($2\text{H}_2\text{O} + 2\text{e}^- \rightarrow \text{H}_2 + 2\text{OH}^-$; $E_{\text{H}^+/\text{H}_2} = \eta_c - 0.059 \text{ pH}$, V vs SHE) and the \rightarrow oxidation of oxygen ($2\text{H}_2\text{O} \rightarrow \text{O}_2 + 4\text{H}^+ + 4\text{e}^-$; $E_{\text{O}_2/\text{H}_2\text{O}} = 1.23 - 0.059\text{pH} + \eta_a$, V vs SHE), where η_c and η_a are cathodic and anodic \rightarrow overpotentials which are caused by the kinetic polarization and depend on the electrode material.

Water — Table. Physical properties of water

Property	Value
Molar mass	18.015 g mol ⁻¹
Boiling point	100 °C at 1.01325 × 10 ⁵ Pa
Freezing point	0 °C at 1.01325 × 10 ⁵ Pa
Triple point	273.16 K at 613.283 Pa
Density	1 g cm ⁻³ at 4 °C
Density maximum	3.98 °C
Surface tension	0.073 N m ⁻¹ at 20 °C
Vapor pressure	2148.09 Pa at 20 °C
Heat of vaporization	40.63 kJ mol ⁻¹
Specific heat	4180 J kg ⁻¹ K ⁻¹ ($T = 293 \dots 373$ K)
Heat conductivity	0.60 W m ⁻¹ K ⁻¹ ($T = 293$ K)
Melting heat	6.02 kJ mol ⁻¹
Dielectric constant	78.54 at 25 °C
Viscosity	1.002 × 10 ⁻³ Pa s at 20 °C
Critical temperature	647 K
Critical pressure	22.1 × 10 ⁶ Pa
Speed of sound	1480 m s ⁻¹ ($T = 293$ K)
Index of refraction	1.31 (ice; 589 nm; $T = 273$ K; $p = p_0$)
	1.34 (water; 430–490 nm; $T = 293$ K; $p = p_0$)

Ref.: [i] Cotton FA, Wilkinson G, Murillo CA, Bochmann M (1999) *Advanced inorganic chemistry*, 6th edn Wiley-VCH, Weinheim

ŠKL

Autoprotolysis of water \rightarrow autoprotolysis, \rightarrow water and subentry \rightarrow heavy water

Crystal water — It is water combined with many salts in their crystalline form, i.e., it is situated at certain lattice positions. The amount of this water is fixed and depends on the substance containing it (e.g., $\text{CuSO}_4 \times 5\text{H}_2\text{O}$).

Ref.: [i] Miessler GL, Tarr DA (1998) *Inorganic chemistry*, 2nd edn. Prentice Hall, Upper Saddle River

ŠKL

Electrolysis of water — This is a process of electrochemical decomposition of water into \rightarrow hydrogen and \rightarrow oxygen. Apart from alkaline electrolyzers using 25% KOH solution [i], devices with polymer, or ceramic ion-conducting \rightarrow membranes have been developed for industrial applications [ii].

Refs.: [i] Fletcher EA (2001) *J Sol Energy Eng* 123:143; [ii] Maruyama R, Shiraiishi M, Hinokuma K, Yamada A, Ata M (2002) *Electrochem Solid State Lett* 5:A74

ŠKL

Heavy water — Deuterium (${}^2_1\text{H}$, D) occurs in water at the concentration of about 0.01 mol L⁻¹. Some

physical properties of pure heavy water (D₂O) are the following: freezing point is 3.82 °C at 1.01325 × 10⁵ Pa, boiling point is 101.42 °C at 1.01325 × 10⁵ Pa, density is at maximum at 11.6 °C, the density at 20 °C is 1.1059 g/mL, surface tension is 0.0678 N m⁻¹ and viscosity is 1.26 × 10⁻³ Pa s, both at 20 °C. The equilibrium constant of → *autoprotolysis* is: $a_{\text{D}_3\text{O}^+} a_{\text{OD}^-} = 2 \times 10^{-15}$ [i]. Heavy water is produced by electrolysis of normal water. The standard potential of the D₂/D⁺ couple is about -0.013 V. The values of the separation factor, $S_{\text{D}} = (c_{\text{H}}/c_{\text{D}})_{\text{gas}} / (c_{\text{H}}/c_{\text{D}})_{\text{liquid}}$, are typically 3 to 8 [ii].

Refs.: [i] Weast RC, Lide DR, Astle MJ, Beyer WH (eds) (1990) *CRC handbook of chemistry and physics*. CRC Press, Boca Raton, F-4; [ii] Ross PH (1985) *Hydrogen*. In: Bard AJ, Jordan JJ, Parsons R (eds) *Standard potentials in aqueous solutions*. Marcel Dekker, New York, p 45

SKL

Permittivity of water — See the table *Physical properties of water* and the entry → *permittivity of water*.

Watt — Unit of power named after the Scottish inventor James Watt (Jan. 19, 1736 – Aug. 19, 1819). 1 W = 1 J s⁻¹ = 1 V A. See → *SI derived units*.

FS

Watts bath — The Watts bath is the classical electrolyte for the → *electrodeposition* of functional nickel coatings. It contains nickel sulfate (240–450 g L⁻¹ of the hexahydrate), nickel chloride (45–90 g L⁻¹ of the hexahydrate), and boric acid (30–50 g L⁻¹) and is usually operated between pH 2 and 4.5 and at 40–70 °C. The chloride content of the bath is crucial to ensure the dissolution of the nickel anode. In combination with → *leveling agents* and brighteners the Watts bath is also used for decorative nickel coatings. Its applicability for → *electroforming* is limited due to tensile stresses in the deposits.

Ref.: [i] Watts OP (1916) *Trans Am Electrochem Soc* 29:395

AB

Waver curvature method → *bending beam method*

Weighted digital filtering → *digital filter*

Wenking, Hans



(Aug. 18, 1923, Münster/Westfalen, Germany – June 19, 2007, Buchholz, Germany) Wenking studied physics in Göttingen. In 1952 he joined the Max Planck Institute of Physical Chemistry in Göttingen where he designed various instruments. In 1954, he constructed the first electronic → *potentiostat*. This potentiostat was a main contribution to the rapid development of electrochemical kinetics in the period thereafter. Together with B. Hasenstein and W. Reichardt he founded the cybernetics research group in Tübingen, Germany, and developed instruments to study the movement and optical capability of insects.

Ref.: Dölling R (1998) *Mat Corr* 49:535

RD

Weston normal element (cell) — Electrochemical → *standard cell* showing a particularly stable and reproducible cell voltage. In the international Weston normal element a cadmium amalgam (cadmium content in the solid phase approx. 15 wt %, in the liquid phase approx. 5 wt %, total average 12 to 12.5 wt %, the electrode potential depends only on the temperature, not on the mass ratio of liquid and solid phases) and a mercury electrode (half-cell) are combined according to

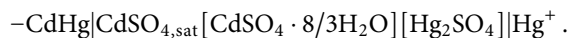

The cell reaction upon discharge is

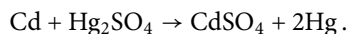

The standard cell voltage is $U^\ominus = U_{20} - 4.06 \times 10^{-5}(T - 20) - 9.5 \times 10^{-7}(T - 20)^2 - 0.01 \times 10^{-6}(T - 20)^3$ V with T = temperature in °C. The cell voltage at $T = 20$ °C depends slightly on the actual pH-value of the solution, which may vary slightly. Also it is fixed by the solution composition and an addition of sulfuric acid to pH = 1.4 ± 0.2. A typical value is $U = 1.01830$ V, values up to $U = 1.01865$ V have been reported. In the standard Weston cell (also called unsaturated cell) the electrolyte

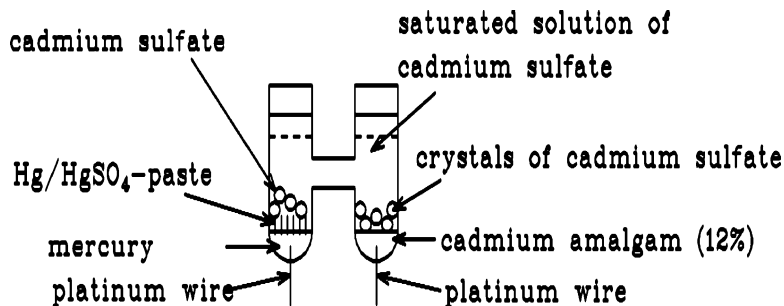

Weston normal element (cell) — Figure

is saturated at $T = 4\text{ }^\circ\text{C}$ with CdSO_4 . The cell voltage $U_{20\text{ }^\circ\text{C}} = 1.0191\text{ V}$ decreases by about 5 to $50\text{ }\mu\text{V}$ per year; it is nevertheless popular because of its very low temperature coefficient of its cell voltage.

Wetting angle — A liquid droplet formed on a flat solid foreign substrate has the “cap-shaped” form of a spherical segment (Figure) with a volume,

$$V(R, \theta_0) = (1/3)\pi R^3(2 - 3 \cos \theta_0 + \cos^3 \theta_0) \quad (1)$$

and a surface,

$$S(R, \theta_0) = \pi R^2 \sin^2 \theta_0. \quad (2)$$

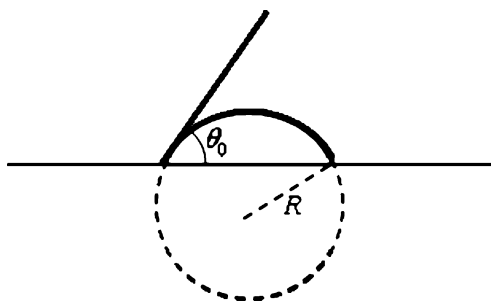

Wetting angle — Figure. Cross section of a liquid droplet formed on a flat foreign substrate

In Eqs. (1) and (2) R is the radius of the homogeneously formed sphere, γ_0 is the interfacial tension between the liquid and the solid, S is the area of the liquid–solid interface, and θ_0 is the wetting angle.

Refs.: [i] Young T (1805) *Philos Trans R Soc* 95:65; [ii] Kaischew R (1980) *Selected works. Academic Publishing House Marin Drinov*; [iii] Milchev A (2002) *Electrocrystallization: fundamentals of nucleation and growth. Kluwer, Boston*

AM

Wetting agents → *electroplating additives*

Wheatstone bridge — Circuit used for high-precision measurements of an unknown electrical → *resistance*, named after Sir Charles Wheatstone (1802–1875), who introduced it in its still known form in 1843, after being initially invented by Samuel Hunter Christie in 1833. The W.b. illustrates the concept of a difference measurement, which can be performed with highest accuracy. Variations on the W.b. can be used to measure → *capacitance*, inductance, → *impedance*, and other quantities, such as the amount of combustible gases in a sample, with an explosimeter. The Kelvin bridge was specially adapted for measuring very low resistances.

A basic W.b. circuit contains four resistances R_1 to R_4 , a constant voltage input U_0 , and a voltage gauge or null galvanometer U_S , as illustrated in the Figure. The bridge supply is usually → *direct current*, but → *alternating current* can be used if all four resistances are nonreactive. The W.b. is balancing two legs of a bridge circuit, one leg of which includes the unknown component, i.e., the current in a conductor splits into two parallel paths and then recombines into a single conductor, enclosing a loop (see Figure).

W

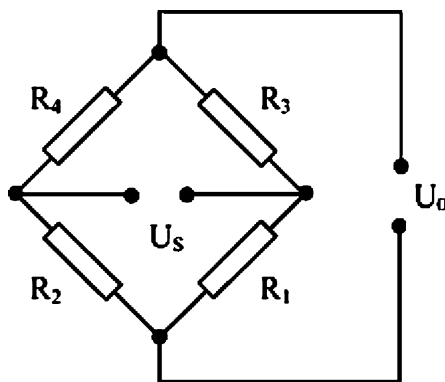

Wheatstone bridge — Figure

Within the nomenclature used, R_4 is the unknown resistance to be measured; R_1 , R_2 , and R_3 are resistors of known resistance, and the resistance of R_1 is (mostly, but not in all W.b. arrangements) adjustable. If the ratio of the two resistances in the known leg (R_1/R_3) is equal to the ratio of the two in the unknown leg (R_4/R_2), then the voltage U_S measured through the “bridge” will be zero, and no current flows between the midpoints. As mentioned above, detecting zero current can be done to extremely high accuracy, i.e., if the three known values are known to a high precision, then R_4 can be measured to a high precision: $R_4 = (R_2/R_3)R_1$. Usually, the adjustable resistance (here: R_1) is varied until this condition is reached; the current direction indicates a positive or negative deviation of R_1 . Alternatively, with none of the three known resistances adjustable, the voltage, or current flow through the galvanometer, can be used to calculate the value of R_4 , using Kirchhoff’s circuit rules.

Refs.: [i] Gibilisco S (ed) (2001) *The illustrated dictionary of electronics*, 8th edn. McGraw-Hill, New York; [ii] Westphal WH (ed) (1952) *Physikalisches Wörterbuch*. Springer, Berlin, p 683

MHer

Whewell, William



©Lancaster Museum)

(May 24, 1794, Lancaster, England – Mar. 6, 1866, Cambridge, England) English polymath, neologist, and philosopher of science. Educated at Heversham Grammar School (Westmoreland) and Trinity College (Cambridge); ordained 1825; Professor of Mineralogy at Cambridge University 1828–32; Knightbridge Professor of Moral Philosophy at Cambridge University 1838–1855; Master of Trinity College 1841–66. Whewell (pronounced “yule”) had a strong intellectual influence on several giants of nineteenth century science, including → *Faraday*, Darwin, Lyell, and Airy. Faraday, in particular, often turned to Whewell for philosophical and terminological assistance. Among the electrochemical terms suggested to Faraday by Whewell were → *anode* [i], → *cathode* [i], and → *ion* [ii]. Other useful words included Eocene, Miocene, and Pliocene for Lyell;

diamagnetic and paramagnetic for Faraday, biometry for Lubbock, and astigmatic for Airy. Remarkably, he also invented the words scientist, physicist, and radiative, and, in the philosophy of science, introduced the terms consilience, Catastrophist, and Uniformitarian. Throughout his life he championed the concept that correct nomenclature was vital to the progress of science.

Refs.: [i] *Lett to M Faraday*, 25 April 1834. In: *Todhunter I* (1876) William Whewell, D.D., Master of Trinity College, Cambridge. *An account of his writings with selections from his literary and scientific correspondence*. 2 vols. London; [ii] *Lett to M Faraday*, 5 May 1834. *ibid*.

SF

Wiedemann, Gustav Heinrich

(Reproduced from (1893) *Ann Phys* 50: frontispiece)

(Oct. 2, 1826, Berlin, Germany – Mar. 23, 1899, Leipzig, Germany) 1847 Ph.D. in Berlin, 1850 habilitation in Berlin. 1854–63 Professor of Physics in Basel, then in Braunschweig (1863–1866) and Karlsruhe, since 1871 in Leipzig. In 1853 Wiedemann discovered together with Rudolph Franz (a high-school teacher) the law that is later referred to as the Wiedemann–Franz law about the relation between electrical and heat → *conductivity* [i]. Further he worked on electricity and magnetism, and on → *electroosmosis*, discovering that the hydrostatic pressure is proportional to the potential difference applied across a diaphragm [ii]. He wrote a most influential set of books on galvanism and electricity [iii]. Following → *Poggendorff*, he became in 1877 editor of the journal “*Annalen der Physik*”.

Ref.: [i] *Wiedemann G* (1853) *Ann Phys* 89:497; [ii] *Wiedemann G* (1856) *Ann Phys* 99:177; [iii] *Wiedemann G* (1861) *Die Lehre vom Galvanismus und Electromagnetismus*, vol. 1 (1861), 1st edn, vol. 2 (1874), 2nd edn, vol. 3 (1895), 2nd edn. Vieweg, Braunschweig

FS

Wien effect — In large → *electric fields* (*deviations in the*) it is possible to observe deviations from the relationship between the applied → *voltage* and the flowing electrical → *current* in a → *conductance* measurement following

→ *Ohm's law* (deviations) [i]. As observed by Wien (and subsequently called first Wien effect) growing values of conductance are observed. Basically this can be due to deviations from Stokes-like behavior of the ions, changes in the interionic interaction, and changes in the degree of dissociation. The first effect will become noticeable only at very large velocities ($>10^5 \text{ cm s}^{-1}$), thus it has no effect under the conditions studied so far. The second effect can be understood when considering the properties of the ionic cloud and its relaxation behavior. At sufficiently large fields, and the corresponding velocities, the ion moves along distances within the relaxation time comparable to the radius of the ionic cloud. Thus the impeding effect of the relaxation effect and the → *electrophoretic effect* disappear. Because the relaxation time depends on concentration, valency, and mobility of the ions, the actual Wien effect should vary from ion to ion, and this is observed experimentally [ii]. A complete theory of the Wien effect for binary electrolytes has been developed by Wilson (for a review see [iii]). The third effect (also called second Wien effect) can be observed with incompletely dissociated weak electrolytes. A large electric field enhances dissociation (i.e., splitting of a proton or – to a lesser degree – of another cation), whereas the recombination reaction is not affected. This results in a larger concentration of anions and consequently an increase of electrolytic conductance. According to → *Onsager* the dissociation constant at a field strength E in a medium with a → *dielectric constant* ϵ is

$$k_d^E = k_d^0 \left(1 + \frac{z^{+2} z^{-2} (\lambda_0^+ \lambda_0^-)}{z^+ \lambda_0^- + z^- \lambda_0^+} \cdot 9.636 \frac{E}{\epsilon T^2} \right).$$

Refs.: [i] Wien M (1927) *Ann Physik* 83:327; Wien M (1928) *Ann Physik* 85:795; Wien M (1929) *Ann Physik* 1:407; [ii] Kortüm G (1957) *Lehrbuch der Elektrochemie*. Verlag Chemie, Weinheim; [iii] Eckstrom HC, Schmelzer C (1939) *Chem Rev* 24:367

Wiesner, Karel František



(Nov. 25, 1919, Prague, then Czechoslovakia, now Czech Republic – Nov. 28, 1986, Fredericton, Canada) Student of → *Brdička* in Prague. He initiated exact study of electrode processes controlled by rates of chemical reactions [i–iii]. On this basis he interpreted, e.g., electroreduction of sugars as controlled by rate of transformation of cycloacetal form into reducible tautomer [iv, v], and experimentally measured rates of recombination of some reducible acids [vi, vii]. In Canada he excelled in organic chemistry of natural compounds. In 1969 he was elected as Fellow of the Royal Society. For a detailed biography see [viii].

Refs.: [i] Wiesner K (1943) *Z Elektrochem* 49:164; [ii] Brdička R, Wiesner K (1943) *Naturwiss* 31:247; [iii] Wiesner K (1955) *Anal Chem* 27:1712; [iv] Wiesner K (1947) *Coll Czech Chem Commun* 12:64; [v] Los JM, Wiesner K (1953) *J Am Chem Soc* 75:6346; [vi] Clair E, Wiesner K (1950) *Nature* 165:202; [vii] Wiesner K, Wheatley, Los JM (1954) *J Am Chem Soc* 76:4858; [viii] Schneider WG, Valenta Z (1991) *Biographical Memoirs of Fellows of the Royal Society* 37:462

MHey

Width at half-height — It is better known as ‘full width at half maximum’, FWHM, or often named ‘full width at half height’, FWHH, and stands for the expression of the extent of a function, given by the difference between the two extreme values of the independent variable at which the dependent variable is equal to the half of its maximum value. FWHM is often applied to Gauss- or Lorentz-type functions, to express the spectral width of sources, the duration of pulse waveforms, and, especially in analytical chemistry, for defining the resolution of spectrometers: The instrumental resolution is expressed as FWHM (Q) vs Q . In this context, FWHM denotes an important and frequently used overlap criterion relating to two adjacent peaks of equal size and shape (Gaussian, Lorentzian, triangular) in a spectrum. If the considered function is the normal, i.e., Gaussian-type, distribution, the FWHM is related to the standard deviation σ by the

RH

expression: $\text{FWHM} = 2\sigma\sqrt{2\ln 2}$, where σ is the standard deviation. Moreover, it can be expressed as: $\text{FWHM} = 2Q\sqrt{\ln 2/\pi}$, where Q is the equivalent bandwidth or the area under a function divided by the function's maximum height, $Q = 2\pi/d$, and: $\text{FWHM} = 2A\sqrt{\ln 2}$, where A is a space/time constant. FWHM is inversely proportional to the inherent spectral line-width: $\tau_2 = (\pi W)^{-1}$, where W is the FWHM of the single Lorentzian peak, present in the upper limit of very rapid exchange (i.e., high-T limit). In the angular frequency domain, one has: $\tau_2 = (W/2)^{-1}$.

Refs.: [i] Meier PC, Zünd RE (2000) *Statistical methods in analytical chemistry*, 2nd edn. In: Winefordner JD (ed) *Chemical analysis – a series of monographs on analytical chemistry and its applications*, vol. 153. Wiley, New York; [ii] *Guide for use of terms in reporting data in analytical chemistry* (1986) *Anal Chem* 58:269–270

MHer

Wigner–Seitz radius (WSR), r_s — The Wigner–Seitz radius is the radius of a sphere equivalent to the elementary Wigner–Seitz cell (WSC) in a crystal. The WSC is constructed in the following way: One connects an atom of the crystal lattice with all nearest translationally equivalent atoms by straight lines. Then one puts a perpendicular plane in the middle of each line. The geometrical figure formed as the intersection of these planes represents a WSC. In general, this represents a polyhedron. It is often approximated by a sphere of the radius r_s for practical estimations. This radius characterizes an average distance between the equivalent atoms in the crystal lattice, and $v_s = 4\pi r_s^3/3$ determines an average volume of the WSC.

Ref.: [i] Zeiman JM (1964) *Principles of the theory of solid*. Cambridge University Press, Cambridge

AMK

Wilhelmy, Ludwig Ferdinand — (Dec. 25, 1812, Stargard, Germany, now Stargard Szczeciński, Poland – Feb. 18, 1864, Berlin, Germany) Wilhelmy studied pharmacy in Berlin, and opened an apothecary in Stargard. However, he sold the apothecary in 1843 in order to study physics and chemistry in Berlin, Gießen, and Heidelberg. In 1846 he received his Ph.D. for a thesis entitled “Die Wärme als Maas der Cohäsion” (“Heat as a measure of cohesion”). Thereafter he traveled to Italy and France, where he worked with Henry Victor Regnault (1810–1878) at the Collège de France in Paris. Finally he habilitated in Heidelberg in 1849 [i] with a thesis entitled “Versuch einer mathematisch-physikalischen Wärme-Theorie” (“Towards a mathematical-physical theory of heat”) [ii]. In 1852 he published a book on the physical

basis of physiology and psychology [iii]. He was an academic lecturer in Heidelberg from 1849 to 1854. Thereafter he lived privately in Berlin. He was the first to formulate a chemical rate law as a differential equation, which he integrated, and then compared the results with experimental data [iv]. The first reaction studied in this way was the inversion of sucrose by acid [v, vi]. In 1863 he published his famous paper on the Wilhelmy plate method for measuring the \rightarrow *interfacial tension* [vii, viii] of liquids. See also \rightarrow *Wilhelmy plate (slide) method*.

Refs.: [i] Killy W, Viehaus R (eds) (1999) *Deutsche Biographische Enzyklopädie (DBE)*, vol. 10. KG Saur, München, p 507; [ii] Wilhelmy L (1851) *Versuch einer mathematisch-physikalischen Wärme-Theorie*. Akademische Anstalt für Literatur und Kunst (Karl Groos), Heidelberg; [iii] Wilhelmy L (1852) *Zur physikalischen Begründung der Physiologie und Psychologie*. Akademische Anstalt für Literatur und Kunst (Karl Groos), Heidelberg; [iv] Laidler KJ (1985) *Arch Hist Exact Sci* 32:43; [v] Wilhelmy L (1850) *Ann Phys* 81:413, 499; [vi] Wilhelmy L (1891) *Über das Gesetz, nach welchem die Einwirkung der Säuren auf den Rohrzucker stattfindet*. In: *Ostwalds Klassiker der exakten Wissenschaften No 29*. W Engelmann, Leipzig; [vii] Wilhelmy L (1863) *Ann Phys* 119:177; [viii] Wilhelmy L (1864) *Ann Phys* 122:1

SF, FS

Wilhelmy plate (slide) method — In 1863 \rightarrow *Wilhelmy* described a method for measuring surface tension (\rightarrow *interfacial tension*) which involved the measurement of the force acting on a vertically hanging plate (slide) that was touching the surface of a liquid [i]. The measured total weight was: $w_{\text{total}} = w_{\text{plate}} + \gamma p$ (where w_{plate} was the weight of the plate without touching the surface, γ was the interfacial tension, and p was the perimeter of the plate where it contacted the liquid). The Wilhelmy plate method can also be used to calculate the \rightarrow *contact angle* Θ between the liquid and the plate because the following equation holds: $\gamma \cos \Theta = (w_{\text{total}} - w_{\text{plate}})/p$ [ii]. The method can even be used for molten salts [iii]. When metal plates are used, the \rightarrow *potential* dependence of the interfacial tension can be measured [iii]. The method can also be used to measure the interfacial tension between immiscible liquids [iv]. Using the Wilhelmy method it is essential that the plate be completely wetted before measurement, so that the contact angle between the solution meniscus and the plate is practically zero, and the plate must be positioned in such a way that no buoyancy effects impinge on the measurement (otherwise they must be taken into account).

See also \rightarrow *electrocapillarity*, \rightarrow *electrocapillary curve*, \rightarrow *Gibbs–Lippmann equation*, \rightarrow *drop weight method*, \rightarrow *ring method*, \rightarrow *Lippmann capillary electrometer*, \rightarrow *Wilhelmy*.

Refs.: [i] *Wilhelmy L (1863) Ann Phys 119:177*; [ii] *Adamson AW, Gast AP (1997) Physical chemistry of surfaces, 6th edn. Wiley, New York, pp 23, 363*; [iii] *Peelen WHA, Hemmes K, Kamping H, Bos M, de Witt JHW (1998) J Solid State Electrochem 2:334*; [iv] *Burri J, Hartland S (1977) Colloid & Polymer Sci 255:675*

Winslow effect → *electrorheological fluids*

Wöhler battery — The German chemist Friedrich Wöhler (July 31, 1800–Sep. 23, 1882), who has developed a method to prepare metallic aluminum, suggested a → *battery* consisting of one aluminum electrode in concentrated nitric acid, and another aluminum electrode placed in dilute hydrochloric acid or sodium hydroxide solution. The latter electrode could also be replaced by a zinc electrode.

Ref.: [i] *Hauck WP (1883) Die Galvanischen Batterien, Accumulatoren und Thermoäulen, 2nd edn. Hartleben's Verlag, Wien*

Wollaston, William Hyde



(Aug. 6, 1766, East Dereham, Norfolk, England – Dec. 22, 1828, London, England) Educated at Charterhouse, 1774–1778 and at Gonville and Caius College (pronounced Kees College), Cambridge, 1782–1787. MD, 1793; Fellow of the Royal Society 1793. English physician who made important contributions to electrochemistry, metallurgy, mineralogy, and optics (despite transient partial blindness on both eyes from 1800 onwards). In 1801 he showed that electricity from a Voltaic pile arose from the metal/solution interface not the metal/metal interface, thus presaging modern electrochemistry. He also explained the differences between the new galvanic electricity and the old frictional electricity. In particular, he showed that the pile of → *Volta* delivered less tension (later called → *voltage*) and more quantity (later called → *current*) than frictional devices [i]. In the same year he perfected a powder method of preparing platinum in malleable form, and thus established the

platinum metals industry [ii]. Shortly thereafter, he reported the discovery of the elements rhodium [iii] and palladium [iv]. In 1813 he invented a robust method of producing extremely fine (1 micrometer diameter) platinum wire, today known as → *Wollaston wire* [v]. His final contribution to electrochemistry was to explain the behavior of → *Ampère's* magnetically interacting wires “upon the supposition of an electromagnetic current passing round the axis of [each]” [vi]. In addition to his electrochemical achievements, Wollaston developed the refractometer (1802), discovered the dark lines in the solar spectrum (1802), invented the reflecting goniometer (1809), discovered the first amino acid (cystine) to be found in the human body (1810), proposed the concept of equivalent weight (1813), and invented the “Wollaston Doublet” lens for microscopy, with which “Dr Wollaston saw the finest striae and serratures... upon the scales of a gnat's wing” [vii].

FS

FS

Refs.: [i] *Wollaston WH (1801) Philos Trans R Soc Lonon 91:427*; [ii] *Wollaston WH (1801) Cambridge University Library, Private Notebook G, p 23*; [iii] *Wollaston WH (1804), Philos Trans R Soc London 94:419*; [iv] *ibid 95:316*; [v] *ibid 103:114*; [vi] *Heilbron JL (1981) The electrical field before Faraday. In: Cantor GN, Hodge MJS (eds) Conceptions of ether: studies in the history of ether theories 1740–1900. Cambridge University Press, New York*; [vii] *Brewster D (1831) A treatise on optics. Longman, Rees, Orme, Brown and Green, and John Taylor, London, p 342*

SF, FS

W

Wollaston pile — This was a variety of the → *Volta pile* developed by → *Wollaston*. The zinc plates were surrounded on both sides by copper plates as to increase the efficiency of the battery.

Ref.: [i] *Hauck WP (1883) Die Galvanischen Batterien, Accumulatoren und Thermoäulen, 2nd edn. Hartleben's Verlag, Wien*

FS

Wollaston wire → *Wollaston* invented the following technique to fabricate extremely thin metal wires: A platinum wire was situated in the center of a cylinder which was filled with melted silver. After solidification the resulting silver cylinder was stretched in a machine for wire making until the silver wire was so thin that the inner platinum wire reached a sub-micrometer diameter. The stretching process was followed by dissolution of the silver in nitric acid, leaving the inner platinum wire. Wollaston wires have been used for fabrication of → *ultramicroelectrodes* [i], tips for scanning tunneling microscopy (see → *STM, in situ electrochemistry*), etc.

Ref.: [i] *Fleischman M, Pons S, Rolison DR, Schmidt PP (eds) (1987) Ultramicroelectrodes. Datatech Systems, Morganton*

FS

Work (electrical) — Consider a single-phase system in which there is also a finite electric potential. Further consider a point-sized charged species within that system. Then its \rightarrow *electrochemical potential* $\bar{\mu}_i$, \rightarrow *chemical potential* μ_i , and electric \rightarrow *potential* ϕ_i are related by the equations

$$\begin{aligned}\bar{\mu}_i &= \mu_i + z_i F \phi_i \\ \bar{\mu}_i &= \mu_i^\ominus + RT \ln a_i + z_i F \phi_i\end{aligned}$$

where μ_i^\ominus is the standard chemical potential in the absence of the electric potential, a_i is the \rightarrow *activity* of the charged species, z_i is its charge number, and F is the \rightarrow *Faraday constant*. The corresponding equation for a system involving several phases (each one of which may have a different electric potential) is simply the sum of the equations for the various phases. Such a multiphase system might be, for example, an interface between an electrode and a solution; an \rightarrow *interface between two immiscible electrolyte solutions* (ITIES); or a solution–membrane–solution system (e.g., a cell wall). Regarding units, we note that the electric potential ϕ_i (also called the electrostatic potential) is defined as the potential energy per unit of charge placed in the electric field, and hence is measured in the electrical unit of volts. By contrast, the electrochemical potential is a thermodynamic potential and hence is measured in joules per mole. Indeed, the electrochemical potential may also be regarded as the partial molar \rightarrow *Gibbs energy* of the species i at the specified electric potential. The **molar electric work** is the triple product $z_i F \phi_i$, which is the work required to raise the electric potential of one mole of charged species i from zero to the ambient electric potential ϕ_i . Its units are joules per mole. By the second law of \rightarrow *thermodynamics*, the electrochemical potential $\bar{\mu}_i$ is necessarily constant and uniform across all phases in a multiphase system at \rightarrow *equilibrium*. However, no such restriction applies to the electric potential ϕ_i at equilibrium. There may therefore be (in fact, often is) an **electric potential drop** inside a multiphase system at thermodynamic equilibrium. This accounts for the widespread existence of \rightarrow *electrical double layers*, \rightarrow *membrane potentials*, space-charge regions, etc. throughout the physical world.

Ref.: [i] Guggenheim EA (1949) *Thermodynamics*. North-Holland Publishing Company, Amsterdam

SF

Work function — The work function (Φ) is defined as the energy required to remove an electron from the bulk

of a phase to a point well outside it. Though the work function is primarily a bulk property of the solid, it is strongly affected by the nature of the surface (crystal plane, adsorbed species), and it includes the energy required to transfer the electron across the surface [i–iii]. The work function of a metal can be expressed as follows: $\Phi^M = E_\infty - E_F$, or for a molar quantity and when free charge density is present in the surface region of phase M: $N_A \Phi^M = -(F\psi^M + \bar{\mu}_e^M) = F\phi^M - \mu_e^M$ where N_A is the Avogadro constant, E_∞ is the electron energy at rest at infinite distance, E_F is the \rightarrow *Fermi energy* or the molar Fermi energy, respectively, F is the \rightarrow *Faraday constant*, ψ^M and ϕ^M are the outer electric and inner electric \rightarrow *potentials* of the metal phase (M), resp., and $\bar{\mu}_e^M$ is the \rightarrow *electrochemical potential* of electrons in the metal phase.

As with a metal, the work function of a \rightarrow *semiconductor* is the difference in energy between the \rightarrow *Fermi level* and the energy of an electron at rest outside the surface [iv–vi]. It may seem strange that the work function is defined in this way when there are usually no allowed energy levels within a semiconductor at the Fermi energy, but the work function is a statistical concept and represents the weight average of the energies necessary to remove an electron from the \rightarrow *valence band* or \rightarrow *conduction band*.

In electrochemistry, it is usual to measure potentials with respect to a stable and reproducible system, known as \rightarrow *reference electrode*. For the vast majority of practical electrochemical problems there is no need to determine \rightarrow *absolute potentials*. However, this is necessary in cases where one wants to connect the relative electrode potential with the absolute physical quantities of the system, like electronic energies, as is the case of the work function. It is possible to convert all relative values of electrode potential to absolute-scale values and to electronic energies. For aqueous systems the \rightarrow *standard hydrogen electrode* potential corresponds to -4.44 V in the physical scale taking electrons at rest in vacuum as reference and the absolute potential is given by the relation $E(\text{abs}) = E(\text{SHE}) + 4.44$ [vii].

Refs.: [i] Mills I, Cvitas T, Homann K et al (eds) (1993) *IUPAC quantities, units and symbols in physical chemistry*. Blackwell Scientific, Cambridge, p 37; [ii] Parsons R (1974) *Pure Appl Chem* 37:503 [iii] Bockris JO'M, Khan SUM (1993) *Surface electrochemistry*. Plenum Press, New York, p 83; [iv] Fromhold Jr AT (1981) *Quantum mechanics for applied physics and engineering*. Academic Press, New York, 1981; [v] Lang ND, Kohn W (1971) *Phys Rev B* 3:1215; [vi] Rhoderick EH (1978) *Metal–semiconductor contacts*. Clarendon Press, Oxford; [vii] Trasatti S (1986) *Pure Appl Chem* 58:955

Working electrode — An electrode at which a given electrode process is examined. Its potential is controlled vs. the → *reference electrode* (see → *three-electrode system*). It can be made of a variety of materials and can have a complex composition and construction. Simplest working electrodes are made of metals (such as e.g., gold, platinum, bismuth, and tungsten) and of → *carbon* (graphite and glassy carbon). Composite electrodes may consist of → *conducting polymers*, boron-doped carbon, carbon nanotubes, carbon paste, and many other organic and inorganic materials, see → *electrode materials*, → *surface-modified electrodes* and → *thin film electrodes*. The most popular

shapes of working electrodes are disks, wires and rods, plates, spheres (esp. mercury droplets), but other electrode geometries are frequently reported in the literature. Very small electrodes are called → *ultramicroelectrodes* and sometimes → *nanoelectrodes*. Working electrodes may also be a set of electrodes, see → *array electrodes*.

Refs.: [i] Bard AJ, Faulkner LR (2001) *Electrochemical methods*, 2nd edn. Wiley, New York; [ii] Stojek Z (2005) *Experimental setup*. In: Scholz F (ed) *Electroanalytical methods*. Springer, Berlin

ZS

Wulff's rule → *equilibrium form of crystals and droplets*

X

XANES — X-ray absorption near-edge structure; an application of X-ray absorption spectroscopy where the fine structure of the absorption edge displayed in an X-ray absorption spectrum around and slightly below the absorption edge is analyzed, for details see → *surface analytical methods*.

Refs.: [i] Holze R (2008) *Surface and interface analysis: an electrochemists toolbox*. Springer, Berlin; [ii] Agarwal BK (1991) *X-ray spectroscopy*. Springer, Berlin; [iii] Tsuji K, Injuk J, Van Grieken R (eds) (2004) *X-ray spectrometry: recent technological advances*. Wiley, Chichester

RH

X-ray diffraction → *diffraction*

X-ray absorption spectroscopy → *surface analytical methods*

X-Ray photoelectron spectroscopy (XPS) → *surface analytical methods*

XRD → *diffraction*

Y

Yeager, Ernest Bill



(Sep. 26, 1924, Orange, NJ, USA – Mar. 8, 2002, Cleveland, OH, USA) American electrochemist; BA Montclair State University 1945; MS Western Reserve University 1946, Cleveland; PhD in physical chemistry Western Reserve University 1948, Cleveland. At Western Reserve University, associate professor (1948–1958) then professor (1958–1990) and, since 1983, Frank Hovorka Professor; founder of Case Center of Electrochemical Sciences 1976; retired 1990; more than 270 publications; editor or co-editor of 20 books; research on → *electrode kinetics*, → *spectroelectrochemistry*, → *electrocatalysis*, ultrasound.
Ref.: (2002) *The Electrochemical Society, Interface* 11(1):10

RH

Young's equation — A droplet of a liquid laying on a plane solid and surrounded by the vapor phase (cf. Fig. 1), will exhibit a → *contact angle* Θ that follows from the equation

$$\gamma_{S-V} = \gamma_{S-L} - \gamma_{L-V} \cos \Theta,$$

where γ denotes the → *interfacial tension* between the different phases (S–V: solid–vapor, S–L: solid–liquid, L–V: liquid–vapor) (→ *Young's rule*). This equation is based on the assumption of → *equilibrium* between all three phases. Th. Young (June 13, 1773, Milverton (Somerset) UK – May 10, 1829, London, UK; British physician, physicist, and Egyptologist) had stated this relation in verbal form avoiding mathematical formulae in 1805 [i]. Dupré determined it in algebraic form in 1869 [ii]. The equation is referred to as Young's equation. In case of an oil droplet suspended on the surface of water (Fig. 2) the equation has the form:

$$\gamma_{W-V} \cos \Theta_3 = \gamma_{O-V} \cos \Theta_1 + \gamma_{W-O} \cos \Theta_2,$$

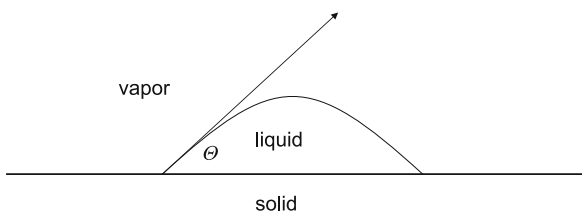

Young's equation — Figure 1. A droplet of a liquid is laying on the flat surface of a solid and surrounded by the vapor phase

where γ denotes the interfacial tension between the different phases (W–V: water–vapor, O–V: oil–vapor, W–O: water–oil).

This equation is basic for determination of interfacial tension and for explaining phenomena of wetting and adhesion [iii–v] including electrochemical experiments [vi]. For the work of adhesion between two immiscible liquids see → *Dupré equation*.

Refs.: [i] Young T (1805) *Philos Trans* 65; [ii] Dupré A (1869) *Theorie Mécanique de la Chaleur*. Gauthier-Villars, Paris; [iii] Adamson AW, Gast AP (1997) *Physical chemistry of surfaces*. Wiley, New York, pp 352; [iv] Hunter RJ (2004) *Foundations of colloid science*, 2nd edn. Oxford University Press, Oxford, pp 102; [v] Payne R (1972) *The study of ionic double layer and adsorption phenomena*. In: Yeager E, Salkind AJ (eds) *Techniques of electrochemistry*, vol. 1. Wiley-Interscience, New York, pp 43; [vi] Ivošević N, Žutić V (1998) *Langmuir* 14:231

FS

Young's rule — A liquid droplet formed on a flat, solid foreign substrate (Fig.) has a volume $V(R, \theta_0)$,

$$V(R, \theta_0) = (1/3)\pi R^3(2 - 3 \cos \theta_0 + \cos^3 \theta_0) \quad (1)$$

whereas the total surface free energy $\bar{\Phi}(R, \theta_0)$ of the three-phase electrochemical system solution (1)–droplet (3)–foreign substrate (2) is given by

$$\bar{\Phi}(R, \theta_0) = 2\pi R^2(1 - \cos \theta_0)\gamma_{13} + \pi R^2 \sin^2 \theta_0(\gamma_{23} - \gamma_{12}). \quad (2)$$

In Eqs. 1 and 2 R is the radius of the homogeneously formed sphere, θ_0 is the → *wetting angle* and γ_{12} , γ_{13} , and γ_{23} are the specific free surface energies at the solution/substrate, solution/droplet, and substrate/droplet interface boundaries, respectively.

The condition for an equilibrium form (→ *equilibrium form of crystals and droplets*) in this system is obtained from the requirement for a minimum of $\bar{\Phi}(R, \theta_0)$ at a constant volume $V(R, \theta_0)$, ($d\bar{\Phi} = 0$, $dV = 0$), and after differentiation of Eqs. 1 and 2 one obtains the simple relation

$$\gamma_{23} - \gamma_{12} + \gamma_{13} \cos \theta_0 = 0 \quad (3)$$

known as Young's rule (→ *Young's equation*).

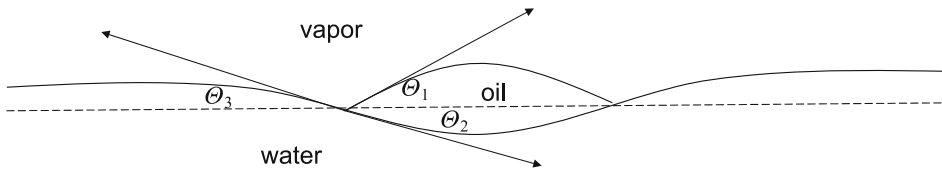

Young's equation — **Figure 2.** An oil droplet suspended on a water surface

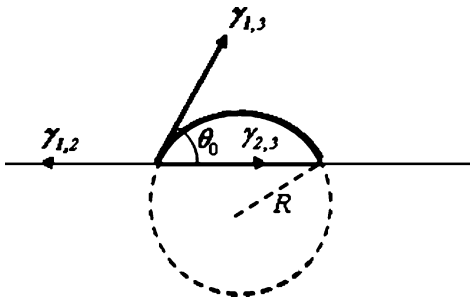

Young's rule — **Figure.** Cross section of a liquid droplet formed on a flat foreign substrate

Equation 3 shows that the wetting angle θ_0 of a cap-shaped liquid droplet on a flat foreign substrate is exactly determined by the values of the specific free surface energies γ_{12} , γ_{13} , and γ_{23} . If the foreign substrate plays the role of a working electrode, the specific free surface energies are potential-dependent quantities and the wetting angle θ_0 is a function of the electrode potential, too.

Ref.: [i] Young T (1805) *Philos Trans R Soc* 95:65

AM

YSZ (yttria stabilized zirconia) → *stabilized zirconia*

Z

Z-value (or polarity parameter Z) — is an index of the ionizing power of a solvent based on the frequency of the longest wavelength electronic absorption maximum of 1-ethyl-4-methoxycarbonylpyridinium iodide in the solvent. The Z-value is defined by $Z = 2.859 \times 10^4/\lambda$ where Z is in kcal mol⁻¹ and λ is in nm, respectively.

Ref.: [i] Muller P (1994) *Pure Appl Chem* 66:1077

WK

Zadra cell — Electrolytic cell employed in → *electrowinning* of gold. The design is based on placing into a perforated cylindrical polymer container: steel wool as → *cathode*, a feeder tube, and a → *current* distributor. The → *anode* is a stainless steel mesh outside the container. Gold-rich solution is fed at low feed rate through the feeder at the bottom of the steel wool-filled compartment, gold is reductively extracted, and the extracted solution passes the polymer container.

Refs.: [i] Pletcher D, Walsh FC (1993) *Industrial electrochemistry*. Blackie Academic & Professional, London; [ii] Zadra JB, Engel AL, Heinen HJ (1952) *US Bureau of Mines Report* 4843

RH

Zamboni pile — This was a → *dry pile* consisting of tin foil on paper and layers of manganese dioxide. The latter was transferred as a paste onto the paper side of the silver paper, and many layers were combined to a so-called dry pile, i.e., only having a wet layer of the manganese dioxide. Other combinations were tin foil–paper–brass foil (or copper-foil).

Refs.: [i] Hauck WP (1883) *Die Galvanischen Batterien, Accumulatoren und Thermosäulen*, 2nd edn. Hartleben's Verlag Wien; [ii] Ostwald W (1896) *Elektrochemie. Ihre Geschichte und Lehre*. Veit Comp, Leipzig; (English transl: Ostwald W (1980) *Electrochemistry. History and theory*, 2 vols. Amerind Publ, New Delhi)

Zdansky–Lonza process → *oxygen*

Zel'dovich, Yakov Borisovich



(ICTP Photo Archives, Trieste, Italy)

(Mar. 8, 1914, Minsk, Russia – Dec. 2, 1987, Moscow, USSR, now Russia) 1931, laboratory assistant at the Institute of Chemical Physics of the Academy of Science (AS) of the USSR. 1936, PhD degree (adsorption, catalysis); 1939, DSc degree (phys-math science); 1946 corresponding member of AS USSR; 1958 actual member of AS USSR. 1965, professor at the Department of Physics of Moscow State University and head of the division of Relativistic Astrophysics at the Sternberg Astronomical Institute. 1965–1983, head of a division at the Institute of Applied Mathematics, AS USSR. 1977, head of the Scientific Council on Fusion at the AS USSR.

Fields of interest: → *adsorption*, catalysis, cavitation, nuclear and thermonuclear weapons, shock waves, nuclear physics, particle physics, astrophysics, physical cosmology, and general relativity. Andrei Sakharov named him “a man of universal scientific interests” and Stephen W. Hawking said to Zel'dovich: “Before I met you here, I believed you to be a ‘collective author’, like Bourbaki.” See also → *Zel'dovich theory* in → *nucleation*, subentry → *non-stationary nucleation*, and → *Roginskii–Zel'dovich kinetics* in → *adsorption kinetics*.

AM

Zel'dovich theory → *nucleation*, subentry → *non-stationary nucleation*

FS **Zeolites** — are any of various natural or synthesized hydrous framework silicates, consisting of interlocked tetrahedrons of SiO₄ and AlO₄, with a ratio (Si + Al)/O equal to 0.5. Z. were firstly discovered and named in 1756, by the Swedish mineralogist Axel Fredrick Cronstedt, in case of stilbite. Other natural z., as, e.g., analcime, heulandite, natrolite, and stilbite, are often formed near volcanic activity centers, have been formed from rocks by interaction with alkaline groundwaters. Synthetic z., produced since the 1930s, can be made by a slow crystallization process of a silica–alumina gel in the presence

of alkalis and organic templates; hydrothermal methods are frequently utilized. Many z. are thermally stable to over 500 °C. The zeolitic framework can be modified by metal cation substitution. Dealumination, to increase the silica content, results in an increase of the hydrophobic nature of the z. The alumino-silicate structure is negatively charged, which makes them suitable microporous hosts for positively charged organic and inorganic species. Unlike most other tectosilicates, z. have larger vacant cages in their structure, that tolerate large cations as, e.g., sodium, potassium, barium, and calcium, as well as molecules and ionic groups such as water, ammonia, carbonate, and nitrate ions, and also organic anions. An important class of z. consists of interconnected spaces that form long, wide channels of varying sizes allowing easy movement/diffusion of the resident ions and molecules into and out of the structure. Z. are characterized by the ability to lose and absorb water (and other molecules) without damage of their crystal structure. The z. pore sizes, commercially available, range from approximately 3 to 8 Å. Ion-exchange/filtration materials based on z. are used in water-softening technology and as adsorbents, as well as in wastewater treatment, for removing both particulate and ionic, heavy metal, impurities. Z. membranes are utilized in a range of sizes and chemically selective separations. Z. are potential candidates for novel microporous materials for fuel cell applications and the production of ultrahigh surface-area catalysts. In electrochemistry, z. have been investigated, together with other microporous and mesoporous materials, as electrode modifiers, i.e., z. coatings, films, or membranes, or so-called zeolite-modified electrodes, ZME. Synthesis and applications of such coherent crystalline z. coatings on metal and inorganic surfaces are intensively studied, also with respect to ion transport processes across liquid-liquid interfaces. A frequent quote is 'zeolitisation' of electrodes, that is, to selectively modify electrodes for the tailored ion-exchange and redox reactions of species into the z. frameworks.

See → *surface-modified electrodes*.

Refs.: [i] Rolison DR (1994) *The intersection of electrochemistry with zeolite science*. In: Jansen JC, Stöcker M, Karge HG, Weitkamp J (eds) *Advanced zeolite science and applications*. Elsevier, Amsterdam; [ii] Walcarius A (2003) *Implication of zeolite chemistry in electrochemical science and applications of zeolite-modified electrodes*. In: Auerbach SM (ed) *CRC handbook of zeolite science and technology*. CRC press, Boca Raton, pp 721-784; [iii] Cejka J, van Bekkum H (2005) *Zeolites and ordered mesoporous materials: progress and prospects*. Elsevier, Amsterdam, p 157

MHer

Zeta potential → *potential*, subentry → *zeta potential*

Zinc — Atomic mass: 65.4 g mol⁻¹; atomic radius: 133 pm; crystal structure: hexagonal; electron configuration: [Ar] 3d¹⁰ 4s²; melting point: 419.5 °C; boiling point: 907 °C; heat capacity: (25 °C) 25.3 J mol⁻¹K⁻¹; electrical resistance: (20 °C) 59.0 nΩ m. Zinc has been by far the most popular → *anode* material for primary → *batteries* because of its good electrochemical behavior, high electrochemical equivalence, compatibility with aqueous → *electrolytes*, reasonably good → *shelf life*, low cost, and availability.

Zinc is also used extensively to → *galvanize* other metals, such as iron, to prevent → *corrosion*. More than 50% of metallic zinc goes into galvanizing steel.

See also → *Leclanché cell*, → *Zn²⁺/Zn electrodes*, → *Zn²⁺/Zn(Hg) electrodes*, → *zinc-air batteries (cell)*, → *zinc-carbon cell*, → *zinc electrowinning*.

Refs.: [i] Habashi F (ed) (1998) *Alloys, preparation, properties, applications*. Wiley-VCH, Weinheim; [ii] Matucha KH (1996) *Structure and properties of nonferrous alloys*. In: Matucha KH (ed) *Materials science and technology. A comprehensive treatment*, vol 8. VCH, Weinheim; [iii] Fleischer A, Lander J, (eds) (1971) *Zinc-silver oxide batteries*. Wiley, Chichester; [iv] Hicks HG (1960) *The radiochemistry of zinc*. McGraw-Hill, New York; [v] Linden D, Thomas BR (eds) (2002) *Handbook of batteries*, 3rd edn McGraw-Hill, New York; [vi] Pauling L (1970) *General chemistry*, 3rd edn. Freeman, San Francisco; [vii] Lide DR (ed) (2003-2004) *Handbook of chemistry and physics*, 84th edn. CRC Press, Boca Raton; [viii] <http://periodic.lanl.gov/elements/30.html>

DA, EZ

Zn²⁺/Zn electrodes — A Zn²⁺/Zn electrode is a metal/metal-ion electrode type with the potential defined reaction: Zn(s) ⇌ Zn(aq)²⁺ + 2e⁻.

The electrode is reversible in regard to cation.

$$E_{\text{eq}} = E_{\text{Zn,Zn}^{2+}}^{\ominus} + \frac{RT}{2F} \ln a_{\text{Zn}^{2+}}.$$

The standard reduction potential is $E_{\text{Zn,Zn}^{2+}}^{\ominus} = -0.7618$ V at 25 °C at a pressure of 101.325 Pa (1 atm) [i].

Exchange current density is $j_0 \approx 2 \times 10^{-5}$ A cm⁻² in (0.5 N ZnSO₄ + 0.005 NH₂SO₄) at 30 °C [ii].

Refs.: [i] Lide DR (ed) (2003-2004) *Handbook of chemistry and physics*, 84th edn. CRC Press, Boca Raton, pp 8-28; [ii] Royter VA, Poluyan ES, Yuza VA (1939) *Acta physicochim URSS* 10:845

DA, EZ

Zn²⁺/Zn(Hg) electrodes — A Zn²⁺/Zn(Hg) electrode is an amalgam-type electrode with the potential defined reaction: Zn(Hg) ⇌ Zn(aq)²⁺ + 2e⁻ (Hg) [i].

The concentration of both oxidized and reduced forms is able to change, therefore:

$$E_{\text{eq}} = E_{\text{Zn,Zn}^{2+}}^{\ominus} + \frac{RT}{2F} \ln \frac{a_{\text{Zn}^{2+}}}{a_{\text{Zn}}}$$

where a_{Zn} is Zn activity in the amalgam.

The standard reduction potential: $E_{\text{Zn,Zn}^{2+}}^{\ominus} = -0.7628 \text{ V}$ at 25°C , and at a pressure of 101.325 Pa (1 atm) [i].

→ Exchange current density is $j_0 \approx 1 \times 10^{-2} \text{ A cm}^{-2}$ in (1 N $\text{ZnSO}_4 + 2 \text{ N Na}_2\text{SO}_4$) at $E_{\text{eq}} = -0.7 \text{ V}$ and 25°C [ii].

Refs.: [i] Lide DR (ed) (2003–2004) *Handbook of chemistry and physics*, 84th edn. CRC Press, Boca Raton, p 8–28; [ii] Ershler BV, Rozetal KI (1953) *Trudi Soveshaniya po elektrochimii* (1950) AN SSSR:446

DA, EZ

Zinc-air batteries (cell) — Zinc-air → batteries (sometimes **mistakenly** called zinc-air → fuel cells), are nonrechargeable electrochemical batteries powered by the oxidation of zinc with oxygen from the air through an alkaline solution. Upon opening the battery to air, oxygen diffuses into the cell and is used as the active cathodic material. With the development of an improved air electrode, the high-rate capability of the system was improved and small button-type batteries are now used widely in hearing aids, electronics, and similar applications. These batteries have a very high energy density as no active cathode material is needed. The wider use of this system and the development of larger batteries have been slowed down because of some performance limitations (sensitivity to extreme temperatures, humidity, and other environmental factors, as well as poor shelf life after activation, i.e., opening to air, and low power density). Nevertheless, because of their attractive energy density, zinc-air batteries are now seriously being considered for a number of applications from portable consumer electronics, and eventually, for larger devices such as electric vehicles, possibly in a reserve or mechanically rechargeable configuration.

Reactions of zinc-air batteries:

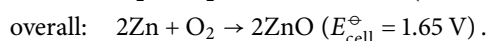
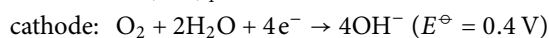
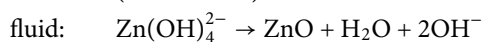
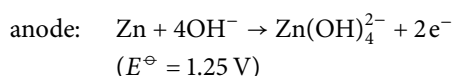

Properties of zinc-air batteries:

1. Very high energy density: 110 to 200 Wh kg^{-1} or 400 to 720 kJ kg^{-1} .
2. These batteries provide continuous energy as they

work electrochemically, and the voltage does not drop until the battery is completely discharged.

3. Very long shelf life, as long as they are sealed (no exposure to active oxygen).
4. Very high self-discharge rate when exposed to air, as the zinc spontaneously reacts with oxygen, and the water in the battery (in the electrolyte solution) tends to dry out.

To prevent pronounced self-discharge, the battery has to be resealed while not in use. The level of water content in the battery can be maintained by the use of a humidifying environment.

However, zinc-air batteries must not be oversaturated with water.

5. These batteries comprise cheap materials and can be produced inexpensively in mass quantities.
6. These batteries are not rechargeable, but the zinc electrode can be recycled or mechanically replaced. The zinc oxide from the used batteries can be collected and converted back to zinc metal.

In the mechanically rechargeable zinc-air batteries, each cell has its own zinc hopper. The electrochemical process continues until the hoppers are empty, at which point the cells are completely discharged and must be refilled. An important aspect of these systems is that the

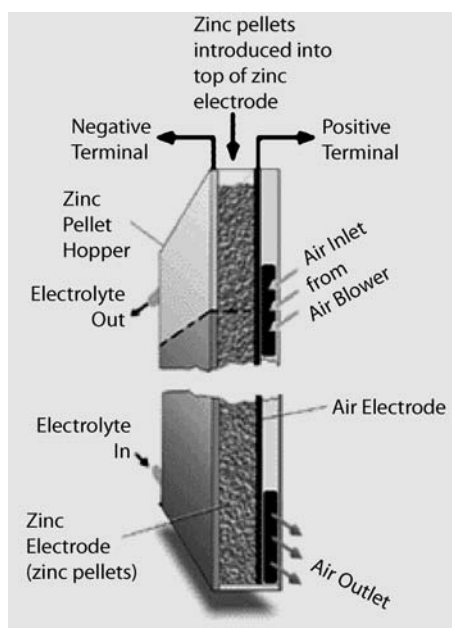

Zinc-air batteries (cell) — Figure 1

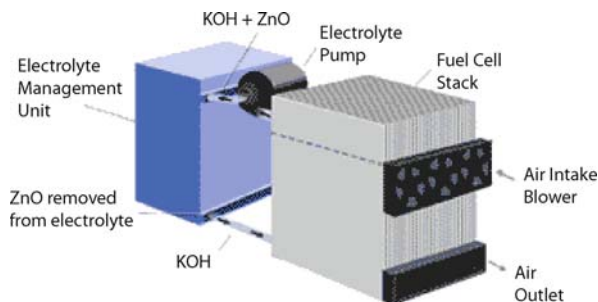

Zinc-air batteries (cell) — Figure 2

bed of zinc particles in each cell is continually washed by a flow of recirculating KOH electrolytes. This removes the soluble zinc reaction product (zincate), and therefore reduces precipitation of discharge products in the electrode active area. Without this, the cell would quickly become clogged with a mixture of zinc and reaction products and would not be refuelable.

The zincate is converted to ZnO in the electrolyte management unit and is removed from the electrolyte via the reaction. At the air cathode, oxygen is supplied to a catalytic surface to form oxides. Hence, the overall cell reaction is zinc plus oxygen reacting to form zinc oxide.

Refs.: [i] Besenhard JO (ed) (1999) *Handbook of battery materials*. Wiley-VCH, Weinheim; [ii] Linden D, Thomas BR (eds) (2002) *Handbook of batteries*, 3rd edn McGraw-Hill, New York; [iii] <http://www.corrosion-doctors.org/Secondaries/zn-air.htm>; [vi] <http://electrochem.cwru.edu/ed/encycl/>

DA, EZ

Zinc-carbon cell → Leclanché cell

Zinc electrowinning — Electrolytic recovery of the metal from an aqueous solution containing Zn ions. In conventional zinc industry practice, concentrates of zinc sulfide ores are roasted; the produced oxide calcine is leached with sulfuric acid and the pregnant leach solution ($\text{ZnSO}_4 + \text{H}_2\text{SO}_4$) is submitted to a sequence of purification steps. The resulting extremely purified solution is fed, as electrolyte, to the → *electrowinning* plant. The → *electrolysis* is carried out by multiple (parallel) systems, with inert anodes and cathodes interleaved in each cell (usually of reinforced concrete, lined with materials resistant to the acid electrolyte). Cells are connected in series, forming independent sections (to allow electrical and chemical isolation for the handling of electrodes and maintenance operations). The several sections of the tank house are also in electrical series connection. Over the years, different types of insoluble anodes have been tested but lead-silver ones (0.5–1.0% Ag to reduce

the corrosion rate during service life) are still widely used. Prior to normal electrolysis operation, these anodes must be conditioned to form a stable PbO_2 layer for minimizing lead contamination of the electrolyte. Current techniques for conditioning are electrolytic → *passivation* ($\text{KF-H}_2\text{SO}_4$ bath), chemical oxidation ($\text{KMnO}_4\text{-H}_2\text{SO}_4$ solution) or sandblasting. Zinc is plated onto aluminum or titanium cathodes from where it is mechanically stripped.

Assuming a strictly pure electrolyte, the electrode reactions are:

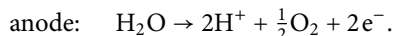
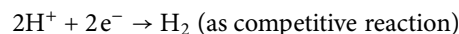
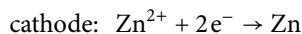

The significant emission of oxygen and hydrogen bubbles, upon bursting the electrolyte surface, ejects acidic aerosol droplets into the cell room environment. This mist is reduced by the addition of surfactants and adequate cell house ventilation improves the working conditions.

To efficiently produce zinc of high-grade quality, the quality of the electrolyte is crucial. Some impurities (Sb, As, Ge, Te, Se) act as depolarizers of hydrogen (forming volatile hydrides), reducing the current efficiency. Others (Cd, Th, Pb) are susceptible to co-deposition with the zinc, lowering the quality of the zinc deposit. Iron and manganese ions suffer cyclic anodic oxidation cathodic reduction with obvious consequence for the electric current consumption. Accordingly, the control of the impurity level, as well as of the usual electrolysis organic additives, is required in industrial electrowinning practice. Also relevant is the electrolyte temperature, as values higher than 40 °C enhance the competitive evolution of hydrogen at the cathode.

Zinc electrolysis consumes a large amount of electric power ($>3000 \text{ kWh t}^{-1} \text{ Zn}$), with a cell voltage higher than 3 V. Usually, the current density is about 500 A m^{-2} , but values ranging from 300 to 750 A m^{-2} are found in normal industrial activity, with current efficiencies of 90–93%.

Refs.: [i] Ashman DW (1993) *An industrial perspective of electrolytic zinc processing*. In: Hiskey JB, Warren GW (eds) *Hydrometallurgy-fundamentals, technology and innovations*. Society for Mining, Metallurgy and Exploration, Littleton, pp 63–81; [ii] Gonzalez-Dominguez JA, Lew RW (1995) *JOM-J Met* 47(1):34; [iii] Allen C (2000) *Performance of a conventional cell design for zinc chloride electrowinning*. In: Dutrizac JE, Gonzalez JA, Henke DM, James SE, Siegmund AH-J (eds) *Lead-Zinc 2000. The Minerals, Metals & Materials Society, Warrendale*

LMA

Zinc-mercuric oxide alkaline cell → Ruben cell

Zirconia → *stabilized zirconia*

Zsigmondy, Richard



(©The Nobel Foundation)

(Apr. 1, 1865, Vienna, Austria – Sep. 23, 1929, Göttingen, Germany) Zsigmondy studied chemistry in Vienna and Munich (Germany), was a private assistant in Munich in 1889, in Berlin in 1890–92, and moved to Graz in 1893. Then followed an important period from 1897–1900 when he worked for the glass producer Schott in Jena (Germany). From 1900–07 he was a private researcher in Jena, in 1907 he lived on a private estate near Trient, and from 1908 to 1929 he was Professor and Director of the Institute of Inorganic Chemistry of the University of Göttingen. He was awarded the Nobel Prize in Chemistry for 1925 for proving the discontinuous nature of colloidal substances and for the development of the appropriate techniques (esp. the so-called ultramicroscope, a dark-field microscope allowing one to see colloidal particles as bright spots). Zsigmondy was therefore one of the founders of colloid science.

Ref.: [i] <http://nobelprize.org/index.html>

FS

Zundel complex — Zundel et al. have proposed from vibrational spectroscopic measurements that the excess hydronium ion is shared equally by two water molecules of an H_5O_2^+ complex (see Figure). In that so-called Zundel complex, the proton cannot be assigned to a particular oxygen; the “O–O” distance is 2.4 Å, i.e., shorter than that distance between water molecules or within hydroxided oxonium ion.

See also → *Eigen complex*, → *water*, → *prototropic charge transport*, → *Grotthuss mechanism*.

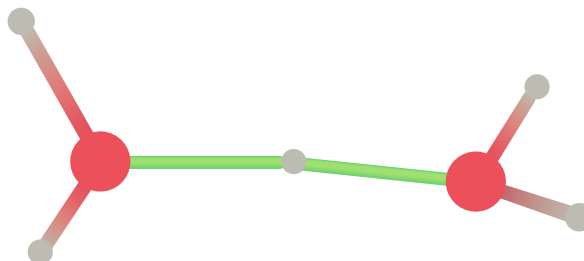

Zundel complex — Figure

Ref.: [i] Zundel G, Metzger H (1968) *Z phys Chem* 58:225

MHer

Zwitter ions — Ions that have opposite charges at different sites of the molecule, e.g., amino acids in the zwitterionic form: $^+\text{H}_3\text{N}-\text{CH}(\text{R})-\text{COO}^-$. ‘Zwitter’ means in German hermaphrodite. Zwitter ions do not move in an electric field and thus conductometric measurements do not allow detecting their hermaphroditic character. → *Kolthoff* and → *Furman* [i] used the term hybrid ion; however, that term is now obsolete.

Ref.: [i] Kolthoff IM, Furman NH (1926) *Potentiometric titrations*. Wiley, New York

FS