

# MANAGING NANO-BIO-INFO-COGNO INNOVATIONS

## CONVERGING TECHNOLOGIES IN SOCIETY

WILLIAM SIMS BAINBRIDGE AND MIHAIL C. ROCO (Eds.)

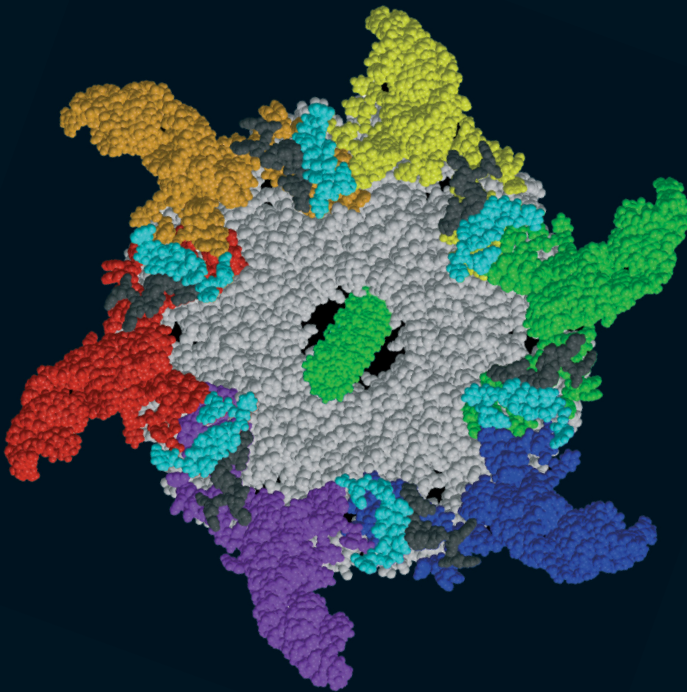

## MANAGING NANO-BIO-INFO-COGNO INNOVATIONS

### About the cover

The central part of the controllable 30-nm DNA-packaging motor of bacterial virus phi29. The motor is driven by six ATP-binding RNA (pRNA) molecules (six color spikes). Similar to a six-cylinder car engine, conformation change and sequential action of the six RNA ensures continuous rotation of the motor with ATP as energy to translocate the DNA (green) to pass the 3,6-nm central channel. Figure by Yinyin Guo adapted from Hoeprich & Guo, 2002. *J. Biol. Chem.* 277:20794 and; Chen & Guo. 1997. *J. Virol.* 71:3864 (courtesy of Prof. Peixuan Guo, Purdue University).

# Managing Nano-Bio-Info-Cogno Innovations

## Converging Technologies in Society

*Edited by*

**WILLIAM SIMS BAINBRIDGE**

*National Science Foundation,\*  
Arlington, VA, U.S.A.*

and

**MIHAIL C. ROCO**

*National Science Foundation,  
Arlington, VA, U.S.A.*

*U.S. National Science and Technology Council's  
Subcommittee on Nanoscale Science, Engineering, and Technology\**

---

\* Any opinions, findings, and conclusions or recommendations expressed here are those of the authors and do not necessarily reflect the views of National Science Foundation or the National Science and Technology Council.

 Springer

A C.I.P. Catalogue record for this book is available from the Library of Congress.

ISBN-10 1-4020-4106-3 (HB)  
ISBN-13 978-1-4020-4106-8 (HB)  
ISBN-10 1-4020-4107-1 (e-book)  
ISBN-13 978-1-4020-4107-5 (e-book)

---

Published by Springer,  
P.O. Box 17, 3300 AA Dordrecht, The Netherlands.

*www.springer.com*

*Printed on acid-free paper*

All Rights Reserved

© 2006 to the complete printed work by Springer, except as noted. Individual authors or their assignees retain rights to their respective contributions; reproduced by permission. After the authors and editors had completed their work, the Directorate for Engineering of the U.S. National Science Foundation decided to acquire a number of copies of the report for limited distribution among some of its science and engineering communities. Therefore, publication of this work was supported in part by a grant (0423742) from the National Science Foundation to The World Technology Evaluation Center (WTEC), Inc. The U.S. Government retains a nonexclusive and nontransferable license to all exclusive rights provided by copyright. Any opinions, conclusions, or recommendations expressed in this material are those of the authors and do not necessarily reflect the views of their respective employers.

Printed in the Netherlands.

## TABLE OF CONTENTS

1. Progressive Convergence. By William Sims Bainbridge and Mihail C. Roco	1
2. The Emergence and Policy Implications of Converging New Technologies. By Mihail C. Roco	9
3. Roadmapping Convergence. By Richard E. Albright	23
4. NBIC Convergent Technologies and the Innovation Economy: Challenges and Opportunities for the 21st Century. By James Canton	33
5. Measuring the Merger: Examining the Onset of Converging Technologies. By Evan S. Michelson	47
6. Collaboration on Converging Technologies: Education and Practice. By Michael E. Gorman and James Groves	71
7. If We Build It, Will They Come? The Cultural Challenges of Cyberinfrastructure Development. By Thomas A. Finholt and Jeremy P. Birnholtz	89
8. Converging Technologies in Developing Countries: Passionate Voices, Fruitful Actions. By Jim Hurd	103
9. Nanotechnology for Biology and Medicine. By James R. Baker	119
10. Biologically-Inspired Cellular Machine Architectures. By Gary H. Bernstein, Leon O. Chua, Árpád I. Csurgay, Patrick Fay, Yih-Fang Huang, Wolfgang Porod, Ángel Rodríguez-Vásquez, Botond Roska, Tamás Roska, Frank Werblin, and Ákos Zarándy	133
11. Cognitive Enhancement and the Neuroethics of Memory Drugs. By Wrye Sententia	153
12. Neuropolicy (2005–2035): Converging Technologies Enable Neurotechnology, Creating New Ethical Dilemmas. By Zack Lynch	173
13. Information Technology and Cognitive Systems. By Robert St. Amant	193

14. Cognitive Technologies. By William Sims Bainbridge	203
15. NBIC Convergence and Technology-Business Coevolution: Towards a Services Science to Increase Productive Capacity. By Jim Spohrer, Douglas McDavid, Paul P. Maglio, and James W. Cortada	227
16. An Ethic for Enhancing Human Performance Through Integrative Technologies. By George Khushf	255
17. Science Confronts the Law. By Sonia E. Miller	279
18. Human Enhancement and the Emergent Technopolitics of the 21st Century. By James J. Hughes	285
19. Coevolution of Social Science and Emerging Technologies. By Bruce E. Tonn	309
APPENDIX 1: Survey of NBIC Applications. By William Sims Bainbridge	337
APPENDIX 2: Information Technology for Convergence. By William Sims Bainbridge	347
APPENDIX 3: Commercializing and Managing the Converging New Technologies. By Michael Radnor and Jeffrey D. Strauss	369
Index	379

# 1. PROGRESSIVE CONVERGENCE

*William Sims Bainbridge and Mihail C. Roco, National Science Foundation<sup>1</sup>*

*Abstract:* This introductory chapter briefly defines the “NBIC” unification that is rapidly taking place today among Nanotechnology, Biotechnology, Information technology, and Cognitive science. It then describes how the other chapters address the potential impacts of converging technologies, considers how innovation can be stimulated and steered, and provides a basis for an understanding of the societal implications of NBIC.

## **Introduction**

At this point in history, tremendous human progress becomes possible through converging technologies stimulated by advances in four core fields: Nanotechnology, Biotechnology, Information technology, and new technologies based in Cognitive science (NBIC). Many individual authors had noticed the gathering convergence of technical disciplines, and sociobiologist E. O. Wilson wrote an especially influential 1998 book on the emerging harmony among the sciences. However, convergence became especially visible, and scholarship about its causes and consequences became very active, through a major 2001 conference, sponsored by the U.S. National Science Foundation and Department of Commerce, that resulted in a substantial book (Roco and Bainbridge, 2003). The intellectual basis of convergence was strengthened by three further annual conferences held in Los Angeles in 2003, New York City in 2004, and near Kona, Hawaii, in 2005. The Los Angeles meeting resulted in a second book (Roco and Montemagno, 2004), and this third volume is an outgrowth of the New York conference. The question raised at the first conference – “if visionary activities related to NBIC would have impact?” – has been replaced in the following meetings with “how and when?” – aiming at anticipatory measures for taking advantage better, sooner and in a responsible way for society.

The effort springs from an ongoing attempt to understand the societal implications of nanoscience and nanotechnology, which was energized by a 2000 conference organized by the National Science Foundation at the request of the National Science and Technology Council (NSTC), Subcommittee on Nanoscale Science, Engineering, and Technology (NSET), and the resultant book (Roco and Bainbridge, 2001). Subsequently, a number of workshops and publications have achieved progress in this area (Roco, 2002, 2004, 2005; Roco and Bainbridge, 2002, 2005; Bainbridge, 2003, 2004; Miller,

---

<sup>1</sup> Any opinions, findings, and conclusions or recommendations expressed here are those of the authors and do not necessarily reflect the views of NSF.

2003; Nordmann, 2004; Radnor and Strauss, 2004). NBIC convergence is much more than merely an adjunct of the nano revolution in science and engineering, but it draws great strength from the concurrent and synergistic breakthroughs achieved in the four domains of NBIC in recent years.

### **Nano-Bio-Info-Cogno Unification**

Technological convergence is progressive in two important senses of the term. First, the NBIC fields are in fact progressively merging, step by step, and apparently at an accelerating rate. Second, the unification of the great realms of technology will promote human progress, if they are applied creatively to problems of great human need. Indeed, unless convergence takes place, in both the technical and social realms, it is hard to see how humanity can avoid conflicts, such as those that marred the 20th century, caused by limited resources for available technology and social differences within each county and globally. Only by moving to a higher technological level will it be possible for all of the peoples of the world to achieve prosperity together without depleting essential natural resources to the point at which the future of civilization itself is in doubt.

The great convergence that is taking place today should not be mistaken for the mundane growth of interdisciplinary or multidisciplinary fields. For many decades, small-scale convergence has taken place in areas such as astrophysics, biochemistry, and social psychology. However significant these local convergences have seemed for the scientists involved in them, they pale in comparison with the global convergence that is posed to occur in the coming decades. It will constitute a major phase change in the nature of science and technology, with the greatest possible implications for the economy, society, and culture.

NBIC convergence requires, and is made possible by, the radically new capabilities to understand and to manipulate matter that are associated with nanoscience and nanotechnology. The integration of technology will be based on the unity of nature at the nanoscale, as well as an information system that would cross disciplines and fields of relevance. Conventionally defined as the size range from 1 to 100 nanometers – from 1/1,000,000 to 1/10,000 of the thickness of an American dime – the nanoscale is where complex molecules form, where the building blocks of living cells are structured, and where the smallest components of computer memories and processors are engineered. Remarkably, many of the key structures of the vast human nervous system exist at the nanoscale, such as the vesicles that store neurotransmitters, the gap between neurons across which those neurotransmitters flow, and the pigment molecules in the eye that make vision possible. Recent advances in nanoscience and nanotechnology enable



a rapid convergence of other sciences and technologies for the first time in human history.

Many of the most powerful developments in biotechnology and biomedicine are taking place at the nanoscale. This is true not merely in genetic engineering (with DNA molecules about 3 nanometers in width), imaging (with quantum dots of few nanometers), targeted drugs (with nanoparticles as carriers), and biocompatible prosthesis (with molecules “by design”) – but also in those many branches of biotechnology where improved understanding of the processes that give life to cells would be advantageous. Thus, much biotechnology today – and increasingly more in the future – is a variant of nanotechnology. Beginning students of chemistry are often perplexed when they learn that organic chemistry does not necessarily depend upon biology, because the term refers to a broad class of complex molecules that need not have been produced by living organisms. Synthetic biology and engineering of nanobiosystems are recently introduced terms. Because both nanotechnology and biotechnology often deal with complex molecules, tools and concepts developed in one can be applied in the other, facilitating convergence.

Modern information technology is based on microelectronics, which is rapidly evolving into nanoelectronics. As a first step, computer chips are manufactured by processes such as photolithography that deposit many thin layers of substances on the chip, then etch away unneeded areas. The layers on the chips, as well as the layers on magnetic disks that store data, have become nanoscale thin, and this very thinness gives them unique electric properties. The current advances on nanolayers with special insulation or conducting properties will evolve to three-dimensional nanostructures and devices and may lead to replacing the information carrier from electron charge to new carriers such as electron spin, photon, or quantum state. Recently, the width of the transistors on a chip has also moved into the nanoscale, with some being only 50 nanometers wide. Currently, researchers are exploring a number of avenues for achieving molecular computing – such as building transistors out of carbon nanotubes – that could form the basis of a new generation of computing, achieving much greater information densities and processing speeds with significantly reduced power requirements. At the same time, progress in nanotechnology and biotechnology is dependent upon constantly improved sensing instrumentation and information processing capabilities. Furthermore, hierarchical system approaches with emerging behavior originating from the nanoscale will require new simulation capabilities, and large databases and computers will allow quantitative evaluation of interdependent technological, economic, and social phenomena.

Of the four NBIC fields, cognitive science is the least mature, but for this very reason, it holds very great promise. This is a multidisciplinary convergence of cognitive and perceptual psychology, linguistics, cultural

anthropology, neuroscience, and artificial intelligence aspects of computer science. The incomplete nature of this local convergence is suggested by the fact that to date sociology and political science have not participated significantly in the development of cognitive science, even though many sociologists and political scientists study the formation and transmission of knowledge, belief, and opinion. Although parallel work is being done in economics, much is only loosely connected to cognitive science. Clearly, neuroscience and artificial intelligence tie cognitive science to biology and to information science, but links to nanoscience are also visible on the horizon, both through the emerging understanding of the functions of neurons on the nanoscale and through new nano-enabled research methodologies for studying the brain and human-tool/machine interaction.

As cognitive science matures, it not only gains more and more opportunities for convergence with other sciences but also becomes a solid basis for a range of innovative new technologies advancing individual and group creativity. Human intellectual and social performance will be greatly enhanced by nano-enabled, portable information systems and communication devices, by biotechnology treatments for disorders of the mind or memory, and by increased understanding of how the human brain and senses actually function.

All branches of science and technology may be converging, but NBIC convergence is especially influential. These are major domains, each with huge power to transform human life. Nanotechnology and information technology are enablers, as well as creative fields in their own right, giving other branches of science and technology new powers. Biotechnology and cognitive science directly concern the human body and mind and have the greatest possible implications for human physical and mental health.

### **Exploring NBIC Innovations**

The individual chapters in this book, supplemented by the three appendices, sketch many of the potential impacts of converging technologies, consider how innovation can be stimulated and steered, and provide a basis for an understanding of the societal implications.

Guidance for planning the future is provided in the next four chapters by Mihail C. Roco, Richard E. Albright, James Canton, and Evan S. Michelson. Roco focuses on policies for research and development investment that will drive technological progress in a manner that maximizes human benefit, and on the need for new business models. His chapter provides a practical guide for achieving the idealistic goal of bettering the conditions of human life. Albright offers a specific conceptual tool for planning and anticipating the future, in the form of roadmaps that articulate strategic definition, research direction, technology, and an investment or action plan. Canton argues that

NBIC convergence is integral to an economy based on innovation, and the basis for future energy resources, health care, and the quality of life. With an eye to policy implications, Michelson shows how NBIC convergence can be measured in terms of government spending, university programs, inter-firm strategic alliances, intra-firm technological expansion, and patent citations.

The next group of three chapters focuses on the human challenges we must overcome in order to achieve convergence. Michael E. Gorman and James Groves explain the problems faced when scientists and students from different fields attempt to collaborate, and they draw lessons from their own experience of solving such problems. Thomas A. Finholt and Jeremy P. Birnholtz report the social and cultural difficulties that computer scientists and earthquake engineers experienced in building a collaboratory, and they outline principles that might avoid problems in future projects when a transforming tool like information technology is applied to the needs of a domain of science. Jim Hurd looks beyond the laboratory, and indeed beyond the industrialized world, to describe the powerful mixture of entrepreneurship and idealism that will be required to put NBIC technologies in service of the citizens of developing nations.

Four chapters examine the tremendous opportunities and ethical challenges that arise when convergence gives a prominent role to human biology, especially the brain. James R. Baker explores the diversity of ways in which nanotechnology may provide new diagnostic and therapeutic techniques for intervention with environmental disorders, developmental diseases, and degenerative diseases. A team represented in the NBIC conferences by Wolfgang Perod describes the groundbreaking research that members are doing in developing computational architectures on the basis of detailed examining of the connections between neurons in the functioning mammalian brain. Wrye Sententia analyzes the competing rhetorics that people use in debating the ethics of cognitive enhancement, focusing on the near-term example of pharmaceutical methods for improving human memory. Zack Lynch offers an analytical classification of sectors of a new, emerging industry he calls neurotechnology, that will be made possible as nanotechnology and information technology assist biotechnology in enhancing human brain functions.

Three chapters explore the partnership between information technologies and new technologies based on the cognitive and social sciences. Robert St. Amant explains the principles of human-computer interaction that allow designers to create information systems that best empower, inform, and enable people to achieve their goals. William Sims Bainbridge considers how cognitive technologies can enhance human performance and well-being, focusing on two examples: an artificial intelligence personal advisor, and dynamic lifetime information preservation systems. A team led by Jim Spohrer outlines the shape and purpose of a new, convergent scientific

discipline that must be created, largely rooted in the union of information technology with cognitive science, to allow the services industries to serve their customers to maximum advantage.

The four concluding chapters consider the social, legal, and ethical implications of converging technologies. George Khushf employs philosophical methods to examine the ethical issues associated with the accelerating rate of NBIC technological development and the goal of enhancing human performance. Sonia E. Miller warns that the current legal system is poorly prepared to cope with scientific evidence in an era of converging technologies and urges people both inside and outside the legal profession to take personal responsibility for improving this situation. James J. Hughes uses the instructive example of biotechnology to survey the competing technology-related ideologies that are emerging and that will play an ever-more-important role in the politics of the 21st century. Bruce E. Tonn considers the significant social changes that might result from NBIC convergence, notably the possibilities for increased local self-sufficiency, establishment of non-spatial governments, transformation of people's identities, and emergence of diverse new cultures across the planet.

The three appendices provide perspective on the potential future applications of Converging Technologies, the scientific work currently in progress that will accomplish NBIC, and the questions that must be answered if industry and other societal institutions are to be able to manage the converging new technologies.

## References

- Bainbridge, W. S. 2003. Converging technologies (NBIC). Pp. 389–391 in *Nanotech 2003: Technical Proceedings of the 2003 Nanotechnology Conference and Trade Show*. Boston: Computational Publications.
- Bainbridge, W. S. 2004. Converging technologies. Pp. 126–133 in W. S. Bainbridge (ed.), *Berkshire Encyclopedia of Human-Computer Interaction*. Great Barrington: Mass.: Berkshire.
- Miller, S. E. 2003. Converging technologies: Innovation, legal risks, and society. *Risk Management Newsletter* 1(3): 1, 5–7.
- Nordmann, A. (ed.). 2004. *Converging Technologies – Shaping the Future of European Societies*. European Commission, [www.ntnu.no/2020/final\\_report\\_en.pdf](http://www.ntnu.no/2020/final_report_en.pdf).
- Radnor, M., and J. D. Strauss, (eds.), *Commercializing and Managing the Converging new Technologies*, Northwestern University, 2004.
- Roco, M. C. 2002. Coherence and divergence in science and engineering megatrends. *Journal of Nanoparticle Research* 4: 9–19.
- Roco, M. C. 2004. Nanoscale science and engineering: Unifying and transforming tools. *AIChE Journal* 50(5): 890–897.
- Roco, M. C. 2005. Environmentally responsible development of nanotechnology. *Environmental Science and Technology*, March 1: 106–112A.

- Roco, M. C., and W. S. Bainbridge (eds.). 2001. *Societal Implications of Nanoscience and Nanotechnology*. Dordrecht, Netherlands: Kluwer.
- Roco, M. C., and W. S. Bainbridge. 2002. Converging technologies for improving human performance: Integrating from the nanoscale. *Journal of Nanoparticle Research* 4(4): 281–295.
- Roco, M. C., and W. S. Bainbridge (eds.). 2003. *Converging Technologies for Improving Human Performance*. Dordrecht, Netherlands: Kluwer.
- Roco, M. C., and W. S. Bainbridge (eds.). 2005. *Societal Implications of Nanoscience and Nanotechnology (II)*. Report for National Nanotechnology Initiative. Washington, D.C.: National Science and Technology Council.
- Roco, M. C., and C. D. Montemagno (eds.). 2004. *The Coevolution of Human Potential and Converging Technologies*. New York: New York Academy of Sciences (Annals of the New York Academy of Sciences, vol. 1013).
- Wilson, E. O. 1998. *Consilience: The Unity of Knowledge*. New York: Knopf.

## 2. THE EMERGENCE AND POLICY IMPLICATIONS OF CONVERGING NEW TECHNOLOGIES

*Mihail C. Roco, National Science Foundation, and Chair of the U.S. National Science and Technology's Subcommittee on Nanoscale Science, Engineering and Technology*<sup>1</sup>

*Abstract:* After a brief overview of the general implications of converging new technologies, this chapter focuses on its effects on research and development (R&D) policies and business models as part of changing social relationships. These R&D policies will have implications on investments in research and industry, with the main goal of taking advantage of the transformative development of NBIC. Development of converging technologies must be done with respect for immediate concerns (privacy, toxicity of new materials, unified nomenclature, etc.) and longer-term concerns including human integrity, dignity, and welfare. The efficient introduction and development of converging new technologies will require new organizations and business models, as well as solutions for preparing the economy, such as multifunctional research facilities and integrative technology platforms.

### **Introduction**

Science based on the unified concepts on matter at the nanoscale provides a new foundation for knowledge creation, innovation, and technology integration. The term *convergent new technologies* refers to the synergistic combination of nanotechnology, biotechnology, information technology, and cognitive sciences (NBIC), each of which is currently progressing at a rapid rate, experiencing qualitative advancements, and interacting with the more established fields such as mathematics and environmental technologies (Roco and Bainbridge, 2002). It is expected that converging technologies will bring about tremendous improvements in transforming tools, providing new products and services, enabling human personal abilities and social achievements, and reshaping societal relationships.

Our core idea is to advance an integrative approach for converging science and engineering from the nanoscale, information, and system levels with a refocus on human needs and aspirations. Those needs and aspirations are identified in the development of the biomedical and cognitive areas. Control of matter at the nanoscale and developments in systems approaches, mathematics, and computation allow us for the first time to understand that the natural world and scientific research are closely coupled, complex

hierarchical systems. Implications of converging new technologies would be in key areas of human activity, including:

- Revolutionary tools and products
- Everyday human performance, such as work efficiency, accelerated learning, and increase of group performance
- Changing organizations and business models, policies for reshaping the infrastructure, setting priorities for R&D planning, and other societal relationships; establishment of NBIC science and technology platforms and facilitating the coevolution of new technologies and human potential are envisioned
- Moving toward a “universal information domain of exchange” for ideas, models, and cultures.

Examples of new products and services are pharmaceutical genomics; neuromorphic technology; regenerative medicine; biochips with complex functions; multiscale molecular systems; electronic devices with hierarchical architectures; software for realistic multiphenomena and multiscale simulations, processes, and systems from the basic principles at the nanoscale; new flight vehicles using biomimetics; and quantitative studies with large databases in social sciences. Cognitive sciences will provide better ways to design and use the new manufacturing processes, products, and services, as well as leading to new kinds of organizations, societal interactions, and cultural traits. A survey on potential future applications of converging new technologies is given in Appendix 1.

The National Science Foundation (NSF), the National Aeronautics and Space Administration (NASA), the Environmental Protection Agency (EPA), the Department of Defense (DOD), and the Department of Energy (DOE) have several R&D projects in the area of converging technologies. These projects are at the confluence of two or more NBIC domains, such as developing neuromorphic engineering, improving everyday human performance, “learning how to learn,” and preparing for societal implications of converging technologies. Industry involvement is evident in seed projects and in the R&D strategic plans of several companies. Ethical and other societal implications must be addressed from the beginning of any major converging technologies program. User- and civic-group involvement is essential for taking better advantage of the technology and developing a complete picture of its societal implications. We need a systematic, deliberate, and responsible approach.

After a brief outline of the key areas of relevance of converging new technologies, this chapter evaluates key societal relationships that would be affected by NBIC.

### **Divergence, Convergence, and Integration in Science and Engineering**

There is a longitudinal process of convergence and divergence in major areas of science and engineering (Roco, 2002). For example, the convergence of sciences at the macroscale was proposed during the Renaissance, and it was followed by narrow disciplinary specialization in science and engineering in the 18th through the 20th centuries. The convergence of understanding at the microscale (modeling and simulation by simple components) for various disciplines was advanced in the 19th century, and it was followed by the divergence of various computational platforms such as finite elements and finite differences. The convergence at the nanoscale reached its strength in about 2000, and we estimate that there will be a divergence of the nanosystem architectures in the next decades. The gap between various technological developments and their societal acceptance, and the digital versus analog electronic platforms, are divergence examples. Current convergence at the nanoscale and the information level are happening because of the respective use of the same elements of analysis (i.e., atoms/molecules in nanotechnology or bits/parts in information technology) and of same principles and tools, as well as because of our ability to make cause-and-effect connections from simple components to higher-level architectures. In both nano and information realms, the respective phenomena/processes cannot be separated, and there is no need for discipline-specific averaging methods.

There are various dimensions and scales for convergence. In 2000, convergence had been reached at the nanoworld (Figure 1) when typical phenomena in material nanostructures could be measured and understood with a new set of tools and seen as the basics in biological systems, nanomanufacturing, and communications. Another convergence is expected to be reached on system creation using NBIC in about 2020; building systems from the nanoscale will require the combined use of nanoscale laws, biological principles, information technology, and system integration. The research focus will shift toward networking at the nanoscale and multiscale architectures, artificial tissues and sensorial systems, quantum interactions within nanoscale systems, development of human cognitive potential, knowledge integration, and establishing a universal domain of information exchange for human activities. Molecules will be used as devices, and from their engineered-structure architectures there will emerge fundamentally new functions that will be exploited in information, biological, and thinking systems.

Research will include (a) atomic manipulation for design of molecules and supramolecular systems, (b) controlled interaction between light and matter with relevance to energy conversion among others, (c) exploiting quantum control mechanical–chemical molecular processes, (d) nanosystem



biology for health care and agricultural systems, (e) human-machine interfaces at the tissue and nervous system level, and (f) convergence of NBIC domains. Then, after 2020, one may expect divergent trends as a function of the system architecture. Several possible divergent trends are system architectures based on: 1) guided molecular and macromolecular assembling; 2) robotics; 3) biomimetics; and 4) evolutionary approaches.

**Figure 1. Reaching the Nanoworld (~2000) and NBIC Methods for System Creation from the Nanoscale (2000–2020)**

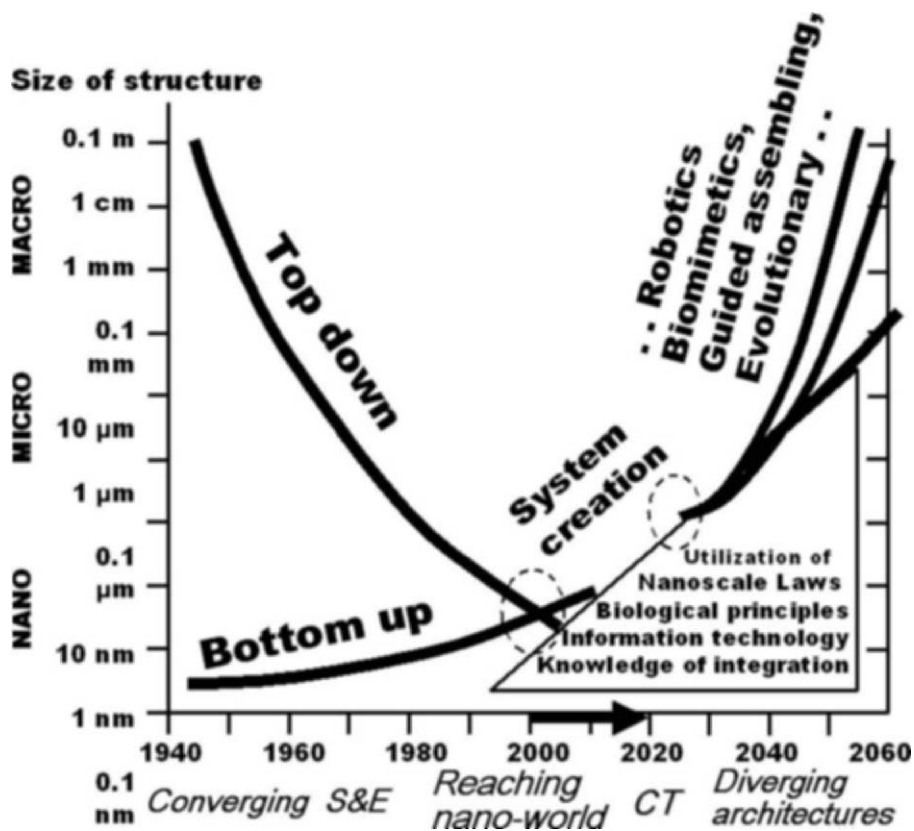

A defining trend in science and engineering is the NBIC convergence that will take place in the first part of the 21st century and that will affect social relationships. The transforming effect on society is expected to be large not only because of the high rate of change in each domain and their synergism with global effect on science and engineering but also because we are reaching qualitative thresholds in the advancement of each of the four domains. Nanotechnology is reaching the foundation of all manmade and living systems, we move toward molecular medicine and nanobiosystems

design, information technology begins to handle sufficiently large databases for quantitative evaluations of societal studies, and we begin to connect physico-chemical phenomena of the brain with behavior.

In the United States, we have started two national initiatives on Information Technology Research (ITR in 1999, about \$2B in FY 2005) and National Nanotechnology Research (NNI in 2000, reaching about \$1.2B in FY 2005), as outlined in Figure 2. (In the diagram, the “push” refers to already-defined programs, whereas the “pull” refers to programs yet to be defined.) Converging Technologies was originally conceptualized as a successor to NNI based on the exploitation of the unity of nature and manmade things at the nanoscale. It is also a potential joint successor of NNI and ITR, as the latest projects funded under ITR would indicate (Appendix 2).

**Figure 2. NBIC Transforming Tools: R&D Programs, 2000**

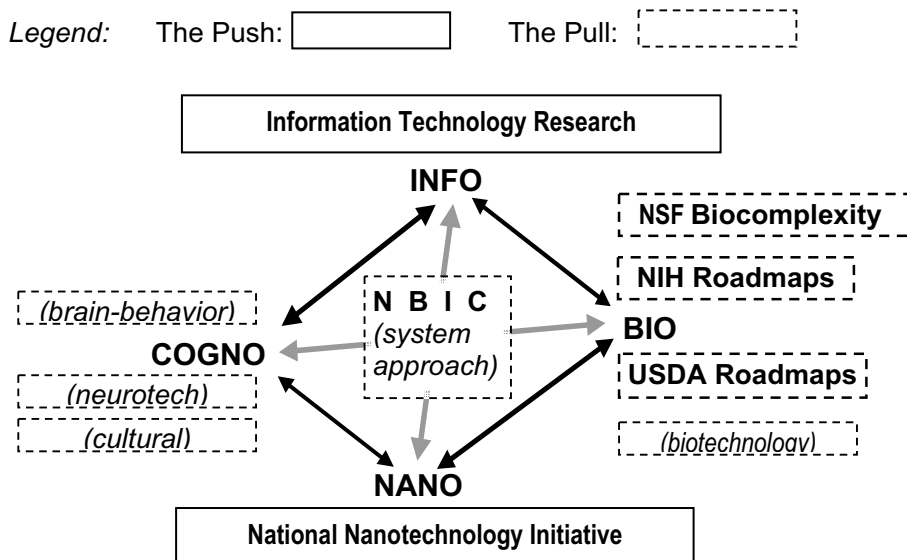

ITR and NNI provide the technological “push” with broad science and engineering platforms. Realizing the human potential, “the pull” would include the biotechnology and cognitive technologies.

Several topical, agency-specific programs have been initiated in the field of biotechnology, such as the National Institutes of Health’s (NIH) Roadmaps (including genome), NSF’s Biocomplexity (in 2000), and the U.S. Department of Agriculture’s (USDA) roadmap. There has been no national initiative on biotechnology and no large-scale programs on cognition, except for the core research programs in the Directorate for Social, Behavioral, and

Economic Sciences at NSF. There was a need to balance this situation. In 2003, the Human and Social Dynamics NSF priority area was launched, funded at over \$20M per year. No special interagency program has been established based on the systems approach or cognitive sciences. The NBIC focus aims to balance the R&D portfolio while maintaining other programs.

The convergence is taking place on the broad scale (including anthropology, environmental research, up to and including social studies), but the most dynamic component driving an accelerating path is NBIC. Reports that focus on NBIC as the emerging core of all converging technologies are

- *Coherence and Divergence in Megatrends in Science and Engineering, 1999–2000* (Roco, 2002)
- *Societal Implications of Nanoscience and Nanotechnology* (Roco and Bainbridge, 2001)
- “Converging Technologies for Improving Human Performance” (Roco and Bainbridge, 2002)
- *The Coevolution of Human Potential and Converging New Technologies* (Roco and Montemagno, 2004)
- Interagency Conference on Research at the Interface of the Life and Physical Sciences (Swaja *et al.*, 2005)
- *Commercializing and Managing the Converging new Technologies* (Radnor and Strauss, 2004; see Appendix 3 of this volume)
- Bylaws of the International Risk Governance Council (IRGC, 2004)
- This volume (*Managing Nano-Bio-Info-Cogno Innovations*, 2006)

The broad NBIC opportunities and the need for measures that are anticipatory – that is, learning before doing, with deliberate and “upstream” choices in research, production, and public policies – and corrective – because all events are part of a complex societal system, the evolution of which is not deterministic – have been identified in the two previous volumes (Roco and Bainbridge, 2003; Roco and Montemagno, 2004).

The 2001 workshop in United States has been followed by other workshops that were at least partially inspired by similar ideas in Canada and Asia (Korea, Japan, Taiwan) since 2003 and in Europe (EC, UK, Spain, Netherlands) since 2004 (Nordmann, 2004). Several non-governmental organizations expressed support, and others expressed concerns about the fast pace of change if societal implications are not properly considered (ETC, 2003; Wilsdon and Willis, 2004). Although the approach in Asia is more proactive for technological advancements, the workshops in Europe have been focused more on societal implications.

This chapter outlines current NBIC research trends and their implications and focuses on policy and business implications. The main NBIC implications are

- Expanding human cognition and communication
- Improving human health and physical capabilities
- Enhancing societal outcomes, including new products and services
- Changing societal relationships, including reshaping models for business and organizations, revising policies for R&D investments and infrastructure, creating science and engineering platforms
- National security
- Unifying science and education

### **Policy Implications of NBIC for R&D and New Investments**

Reaching toward the building blocks of matter for all manmade and living systems with a broad nanotechnology platform makes the transforming tools more powerful and the unintended consequences more important than for other technologies. The integration of nanotechnology with biotechnology, information technology, and cognitive sciences increases the transforming power and potential risks even further. A main concern is a possible instability in human development, because (a) perturbations are created at the foundation of life, and (b) the transforming tools may create perturbations that could be difficult to be controlled after the fact. This underlines the need for an anticipatory and corrective approach in addressing societal implications for each major R&D program or project. In this framework, we have identified several policy challenges of NBIC:

1. Establishing a broad and long-term S&E and infrastructure framework for accelerated techno-economical development using NBIC. One must ensure the availability and synergism of investigative tools, knowledge creation, and production methods supporting various NBIC components. For example, large companies, or groups of smaller companies, would need to develop laboratories and facilities with multidisciplinary NBIC expertise to efficiently engineer and develop new products.

2. Support NBIC integration through long-term strategic planning for each major trend (e.g., NNI, ITR, Biomedical; challenges: cognition, integration), and systematically address the R&D gaps. To systematically address the scientific, technological, and infrastructure development challenges, it is necessary to establish a coordinating group, involving academia, industry, and government and civil organizations.

3. Prepare the technology NBIC S&E platforms, through priorities of infrastructure investments and production incentives. Such platforms are already in development at several companies (such as General Electric) and

government laboratories (such as Sandia National Laboratories). One must include development of nomenclatures, definitions, and regulatory measures.

4. Reduce the usual delay between technological development and societal response. The risks of S&E developments should be evaluated in the general context of potential benefits and pitfalls in the short and long terms. Harmonious introduction of technology should address societal acceptance and the dialog with the public to minimize the delay between research and commercialization in response to societal needs.

5. Identify new evaluation criteria to include the NBIC contribution in the national infrastructure. The criteria of progress must include infrastructure accumulations, increments in citizen education and training, improved working capabilities, and quality of life.

6. Responsible development of NBIC includes respect for human nature, dignity, and physical integrity. The coevolution of society and converging new technologies based on nanoscale control is a main goal. Right to welfare (quality of life, long-term health and safety issues) and access to knowledge must be respected. Several groups call for cultural changes and an international “code of conduct.” There is growing interest concerning the gap between developed and developing countries and how nanotechnology may bring benefits to the underdeveloped regions. In the shorter term, immediate issues on environmental, health, and safety must be addressed in research, societal studies, regulatory measures, and government policies. The International Risk Governance Council (IRGC, 2004) is an example of the international organizations aiming to address overarching risk assessment and management issues. IRGC goals are to develop an independent methodology framework for risk management as well as the principles for “good governance” for consideration by the national governments and international organizations. The people’s needs and concerns should be addressed from various perspectives: knowledge society (intellectual drive), industrial society (help industry and other productive means), and civil society (help societal goals, civil society goals), as outlined in Figure 3.

7. Revise earlier education and training. A key challenge for converging technologies development is the education and training of a new generation of skilled workers in the multidisciplinary perspectives necessary for rapid progress of the new technologies. Interdisciplinary connections reflecting unity in material and information worlds need to be promoted. Coherent science and engineering education and training must be introduced from kindergarten to continuing education, and from scientists to non-technical audiences that may decide the use of technology and its funding. Science and humanity curriculum should be connected in a logical and holistic manner. At the college level, one should encourage convergent programs such as interdisciplinary capstone seminars, double majors, and undergraduate involvement in real research (e.g., the Research Experiences for

Undergraduates activities sponsored by the National Science Foundation). Today, only in their last years of their Ph.D. programs do students begin to understand the broader connections among various domains of learning. An alternative would be to provide freshmen and sophomore students with unifying concepts for matter, information, and biology systems, and then

**Figure 3. Addressing People's Needs and Concerns**

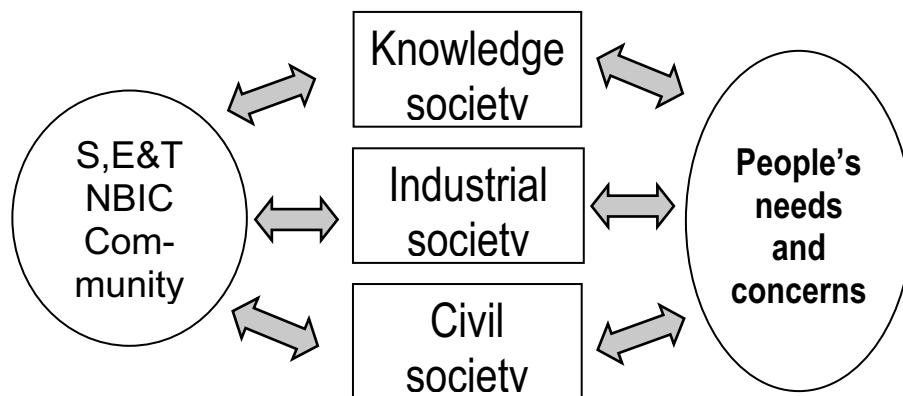

advance with studying various disciplines that focus on phenomena and averaging methods for related length scales. In this way, one could move the same basic concepts from one field to another and create a synergistic view for potential applications in various areas of relevance. Reversing the pyramid of learning would provide a coherent view and motivation to students in physical, chemical, biological, and engineering sciences at all levels.

8. Promote academe-industry-government partnering in advancing NBIC. A successor program combining the tools and ideas developed by the NNI and ITR programs in collaboration with industry and academia, with a focus on people's needs and aspirations in biomedical and cognitive domains, is recommended for accelerated progress in converging technologies.

9. Develop anticipatory responses in the legal system and patent system, and inform the public "up-stream" about the science and technology discoveries (Roco and Bainbridge, 2002; Nature, 2004). Anticipatory measures should address ethical, legal, socio-economic, and political aspects. For example, the new discoveries about brain research and human development in conjunction with converging technologies must be considered in developing and applying the laws, instead of the precedent-seeking legal decisions. The scientific evidence involving complex NBIC issues is increasing in importance in courts and must be considered following rigorous rules for testimonies and expert witnesses (Miller, 2005).

10. Use global context and partnerships. Collaboration with civic and professional societies is necessary in addition to the usual research, development, and production partnerships. For example, the recently founded Converging Technologies Bar Association<sup>1</sup> brings together scientists, engineers, lawyers, and policy makers with the following goals:

- Dialog with legal community, public awareness
- Education and reference material for the legal system
- Source of information on implications of NBIC
- Support creation of converging technologies corridors
- Advocate policies, regulations and legislation.
- Anticipatory measures for the implications of NBIC

### **Changing Organizations and Businesses**

The combined application of NBIC technologies, eventually integrated from the nanoscale and information levels with more traditional technologies, will require availability of specific measuring, design, and manufacturing tools in production clusters under new organization business models. Several ideas for reshaping business and organizations are

- New concept for NBIC technology platforms. Because similar NBIC principles and tools will be applied to various applications, it is expected that multidisciplinary R&D platforms would be developed for multiple areas of relevance. Clusters of “technology parks” are envisioned. Production requiring knowledge and manufacturing will be performed in clusters for integrative technology platforms.
- In order to increase productivity, it is expected that production (manufacturing, energy production, etc.) increasingly will be distributed geographically and on demand, as a function of users’ needs and local production potential. For example, using solar energy with high-efficiency nanomaterials would allow decentralization of large energy-conversion units, and self-assembling nanobiodevices using same software distributed in a network would allow decentralized nanomanufacturing. Because of the high-tech and rapid scientific changes, research will be brought closer to technological development and production.
- Current social, education, and organization theories may become irrelevant and must be reformulated.

---

<sup>1</sup> [www.convergingtechnologies.org](http://www.convergingtechnologies.org)

- Distributed and integrated knowledge creation and design methods must be adopted. In addition, the organizations themselves will become distributed.
- Build new interdisciplinary competencies and partnerships. The educational programs will need to prepare people with the new interdisciplinary and collaborative skills.
- The international dimension increases in importance.

A report on implications of converging technologies on business and organizations has been prepared on the basis of the input received at the NSF-sponsored workshop in 2003. The executive summary of the resultant report prepared by the Northwestern University (Radnor and Strauss, 2004) is included as Appendix 3 of this volume.

### **Key Issues in the Responsible R&D of NBIC in the Short and Long Term**

Societal concerns need to be addressed in the R&D of NBIC from the beginning of the research programs. Typical issues in the short term (such as toxicity of nanomaterials and privacy of wireless communication systems) have a different focus than the long-term challenges (which may lead to fundamental changes in society). The convergence of NBIC with the environmental technologies and societal implications studies is essential in addressing these challenges.

#### *Pressing Issues for Responsible Development of NBIC*

The immediate and continuing issues need to be addressed concurrently with the development of NBIC R&D projects and the creation of respective products. They may be separated into three groups:

- Environmental, health and safety (EHS) knowledge and measures specific to converging new technologies in both research and industrial units.
- Cross-sectors in economy and internationally accepted nomenclatures, norms, standards and regulations for the development of science, engineering, technology and new markets.
- Management of risk analysis for the private sector and government.

#### *Key Issues in the Long Term*

Long-term issues for responsible development of nanotechnology are related to its broader social and economic outcomes, require longer time



intervals to be recognized and changed, and must be on the radar of the governments and civic organizations that work to ensure an equitable and responsible growth. Those issues include:

- Respect of human nature, dignity, and physical integrity. The harmonious coevolution of human potential and converging new technologies based on nanoscale, information, and system control is a main goal. Human right to welfare (quality of life, long-term health and safety issues) and access to knowledge must be respected. Several groups call for cultural changes and a “code of conduct.”
- Balanced and equitable R&D NBIC investment in society. The investments must be done in such a way that the benefits and secondary consequences are properly distributed in society, including for opportunities for education and training and development of knowledge needed to address EHS.
- Human health and environment protection and improvement. This includes approaches and criteria for sustainable development of technology, energy supply, and transportation, including life-cycle analysis of products, materials flow analysis, clean-up techniques on new principles, weather implications, and other global effects. Examples are environmentally benign manufacturing methods.
- Economic, legal, ethical, moral, and other social aspects to adjust and, when possible, anticipate socio-economic changes caused by converging new technologies. The necessary knowledge should be developed through research, creation of databases, and dissemination, including two-way interaction with the public and various interested organizations.

### **Closing Remarks**

Converging nano-bio-info-cogno (NBIC) in conjunction with more traditional technologies are expected to change the way research, product manufacturing, and education are performed. Furthermore, converging new technologies will affect societal interactions, business models, and R&D policies. Key challenges are

- Creating the multidisciplinary science and technology platforms for NBIC
- Preparing a national effort for earlier NBIC education and training
- Developing hybrid manufacturing and global networking using NBIC advances
- Understanding the nervous system and the connection to mind, behavior, education, and work productivity

- Developing capacity to anticipate and manage future opportunities and risks for deliberate and responsible developments
- Respecting human integrity and dignity
- Considering NBIC implications in large R&D programs and investments
- Suiting demographics and sustainable development
- Cultural implications that would require better public understanding and participation in R&D and infrastructure development decisions

We need to develop anticipatory, deliberate, and proactive societal measures in order to accelerate the benefits of converging technologies. Adaptive and corrective approaches in government organizations need to be established in the complex societal system with the goal of improved long-term risk governance. User- and civic-group involvement is essential for taking better advantage of the technology and developing a complete picture of its societal implications. It is recommended that a multidisciplinary, international forum or a coordinating group be established involving academia, industry, government, and civil organizations in order to better address the NBIC scientific, technological, and infrastructure development challenges. Optimizing societal interactions, R&D policies, and risk governance for the converging new technologies can enhance economic competitiveness and democratization.

## References

- ETC. 2003. *The Big Down: From Genomes to Atoms*. Winnipeg, Canada: ETC Group.
- International Risk Governance Council (IRGC). 2004. *Bylaws*. Geneva, Switzerland: International Risk Governance Council. [www.irgc.org/](http://www.irgc.org/).
- Miller, S. E. 2005. Science confronts the law. This volume.
- Nature. 2004. Going public (editorial). *Nature* 431: 883.
- Nordmann, A. (ed.). 2004. *Converging Technologies – Shaping the Future of European Societies*. European Commission. [www.ntnu.no/2020/final\\_report\\_en.pdf](http://www.ntnu.no/2020/final_report_en.pdf).
- Radnor, M., and J. D. Strauss, (eds.), *Commercializing and Managing the Converging New Technologies*, Northwestern University, 2004.
- Roco, M. C. 2002. Coherence and divergence in science and engineering megatrends. *Journal of Nanoparticle Research* 4: 9–19.
- Roco, M. C. 2004. Nanoscale science and engineering: Unifying and transforming tools. *AIChE Journal* 50(5): 890–897.
- Roco, M. C., and W. S. Bainbridge (eds.). 2001. *Societal Implications of Nanoscience and Nanotechnology*. Dordrecht, Netherlands: Kluwer.
- Roco, M. C., and W. S. Bainbridge. 2002. Converging Technologies for Improving Human Performance. *Journal of Nanoparticle Research* 4(4): 281–295.

- Roco, M. C., and W. S. Bainbridge (eds.). 2003. *Converging Technologies for Improving Human Performance*. Dordrecht, Netherlands: Kluwer.
- Roco, M. C., and C. D. Montemagno (eds.). 2004. *The Coevolution of Human Potential and Converging Technologies*. New York: New York Academy of Sciences.
- Swaja, R., B. Hamilton, K. Dill, C. Fraser, and J. Onuchic. 2005. Conference on Research at the Interface of the Life and Physical Sciences. [www.nibib1.nih.gov/Events/110904Conf/interfacereport20405.pdf](http://www.nibib1.nih.gov/Events/110904Conf/interfacereport20405.pdf)
- Wilsdon, J., and R. Willis. 2004. *See-Through Science: Why Public Engagement Needs to Move Upstream*. London: DEMOS.

### 3. ROADMAPPING CONVERGENCE

*Richard E. Albright, Albright Strategy Group*

*Abstract:* The scope of converging technologies is so broad that we must define manageable sub-areas to apply roadmapping methods to understanding and plotting a future direction. This chapter describes a road map structure and some key elements of the structure and provides some examples that will help in steering towards meaningful convergence roadmaps.

#### **Introduction**

The uncertain, cross-disciplinary environment of emerging advanced technologies such as nanotechnology, biotechnology, information technology, and cognitive science makes for very complex planning situations. Application needs may be satisfied by many possible combinations of technologies, and understanding the tradeoffs in a search for a solution can be difficult. Roadmaps make the description of the situation and linkages from application to technology explicit, allowing an informed decision process and providing a tool for communicating the chosen direction and monitoring progress along the way.

A roadmap describes a future environment, objectives to be achieved within that environment, and plans for how those objectives will be achieved over time. It lays out a framework, or architecture, as a way of understanding how the pieces of a complex technological system fit together, interact, and evolve. It links applications, technical challenges, and the technological solutions together, and it helps set priorities for achieving the objectives (Willyard and McClees, 1987; Kostoff and Schaller, 2001; Albright *et al.*, 2002a, 2003).

The best roadmaps are created as a team activity, receiving the views and knowledge of the group of people who will carry out the roadmap's plan. The roadmapping process helps a team gather diverse perspectives on all aspects of the environment and the plan. It also helps the team build consensus and gets buy-in of its members to carry out the plan (Albright, 2002b). Roadmaps also are the basis for the team to describe their objectives and planned actions to customers, suppliers, and stakeholders.

There are many questions teams might seek to answer about the future of the converging technologies: What inventions will be practical enough to become innovations, and when? How will the fields interact to produce innovations? What customer and market drivers and development actions will be needed for commercialization? What are gating factors to innovations

and how can they be satisfied? What are the risks to innovation? Roadmapping provides a framework to answer these and other questions.

### **Roadmap Framework, Objectives, and Formats**

Roadmaps lay out a future objective and answer a set of “why–what–how–when” questions to develop an action plan for reaching the objective (Phaal *et al.*, 2001; Albright, 2002a). The four parts of the roadmap architecture answer the “why–what–how” questions and lay out required actions, the “to do’s.”

The first part defines the domain of the roadmap, the team’s objectives, and their strategy for achieving those objectives – the “why” of a roadmap. The roadmap’s definition and strategy often include market and competitive assessments as well as planned applications. The second part defines direction, or the team’s plans – the “what” of a roadmap. The direction includes challenges, the architecture and evolution of the team’s solution, and measurable performance targets to achieve the objective. The third part describes the evolution of technologies that will be used to achieve the objective – the “how” of a roadmap. This technology roadmap defines the technologies that will be used to implement each part of the architecture. The fourth part defines the action plan and risks – the “to do’s” of a roadmap. This action plan identifies key development actions, resources required, risks, and technology investment strategy. All parts of the roadmap are laid out over time – the “when” of a roadmap.

A roadmap may be constructed beginning with the key needs of the marketplace and customers – a market-pull perspective. Conversely, a roadmap may start with a key technology and seek to define the market needs that could be served with the new technology – a technology-push perspective.

Within the four-part architecture, the contents of roadmaps with the most frequently encountered objectives are outlined in Table 1. The table lists the topics covered in each of the four parts of a roadmap for several types of roadmaps. Science and technology roadmaps plot the future development of a scientific or technical field. The scope of the scientific field and current or potential applications of the technology are linked to key technical challenges of the field. The structure, or architecture, of the field is defined, and trends and potential discontinuities are identified. The challenges are then linked to the evolution of the field in the technology roadmap. Finally, action plans for resource allocation or investment are defined to achieve the most important technological developments. Industry- and government-sponsored roadmaps aim to describe the future of an industry or sector along with actions to move the industry or sector forward. Industry structure and key directions are linked to technical challenges, and those challenges are linked to technology

evolution. Corporations and other organizations use roadmapping for a number of purposes such as product planning, platform planning, or organizational capability planning. Product-technology or platform roadmaps lay out the evolution of a product or platform over time. Capability roadmaps define the capabilities needed for success of a services business or for functional organization such as manufacturing or information technology.

**Table 1: Roadmapping Topics**

	<b>Definition and Strategy: “Know-why”</b>	<b>Direction: “Know-what”</b>	<b>Technology: “Know-how”</b>	<b>Action Plan: “To do”</b>
<b>Science and Technology Roadmaps</b>	Scope of the field; technology applications	Technical challenges; architecture; trends, discontinuities, and objectives	Technology elements and evolution; competitive technologies and costs	Action programs; technology investment; intellectual property and standards; risk roadmap
<b>Industry and Government Roadmaps</b>	Industry structure and position; customer drivers; industry direction	Technical challenges; Architecture; trends and disruptions; learning and targets	Technology elements and evolution; technology alternatives; future costs	Action programs; Technology investment; IP and standards; risk roadmap
<b>Product-Technology and Platform Roadmaps</b>	Market structure and size; customer drivers; competitive strategy	Product roadmap; architecture; product drivers and targets; feature evolution	Technology elements and evolution; competitive position; target costing	Action programs; technology investment; IP and standards; risk roadmap

Figure 1 shows a typical layout of templates for a roadmap, in this case a science and technology roadmap. The template in Figure 1 includes four parts, as defined above. The first part, the definition and scope, covers market and competitive strategy. The second part defines the product direction, the product roadmap. The third part defines the technology evolution, the technology roadmap. Finally, the action plan defines the key programs or projects that will be needed to support the direction, a technology investment summary, and a view of the risks to the plan. Each part is elaborated in a series of pages or panels describing an important element of the plan. The four parts are linked by connecting drivers – customer drivers to product drivers to technology elements to technology

investments. In this way the rationale for decisions on directions taken may be tracked in order to conduct a structured review of gaps and develop plans for closing those gaps.

**Figure 1. The Four Parts of a Science and Technology Roadmap**

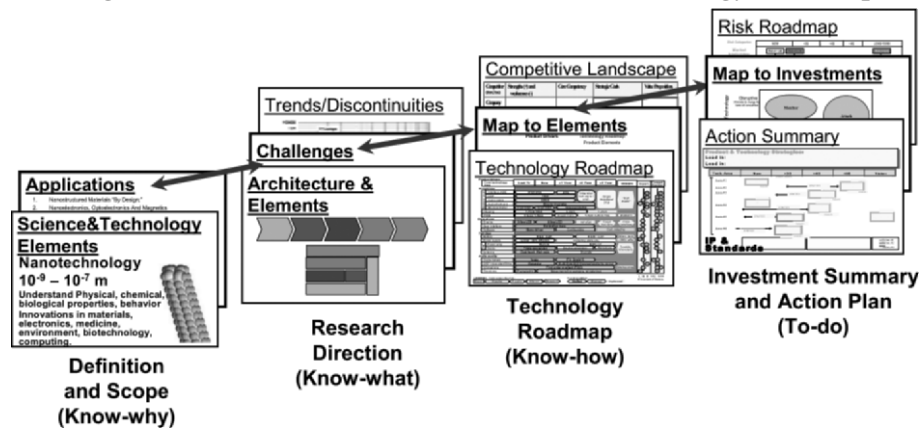

### Drawing a Convergence Roadmap

The first step in roadmapping is to define the scope. At the highest level, we can begin with some draft definitions of the scope of converging technology fields (NNI, 2003):

- Nanotechnology: Technology related to features of nanometer scale ( $10^{-9}$  meters): thin films, fine particles, chemical synthesis, advanced microlithography, and so forth
- Biotechnology: The application of science and engineering to the direct or indirect use of living organisms, or parts or products of living organisms, in their natural or modified forms.
- Information Technology: Applied computer systems – both hardware and software, including networking and telecommunications.
- Cognitive Science: The study of intelligence and intelligent systems, with particular reference to intelligent behavior as computation.

In roadmapping, a team is concerned with understanding and planning for innovations, defined as “the introduction of something new.” For our roadmapping purposes, this is taken to mean new technology put into practice and widespread use. A technology may be invented, but it will not be an innovation until it is widely applied.

Roadmapping should help teams answer questions such as: How will fields interact to create innovations? What innovations will occur and

when? What is needed to create innovations? What are gating factors for innovations?

There are many efforts underway, and many more will come, to plan and roadmap within each of the technology fields. We should focus our roadmapping in two areas. First, we should look where innovations occur at the intersections of fields. For example, at the nanoscale, nanotechnology and biotechnology will often be indistinguishable. Second, we should look to innovations in one area that will be enabled by innovations in another. For example, as biotechnology becomes more information intense, it will be enabled by information technology.

Three key supporting elements of a roadmap are applications/needs, architecture, and growth trends.

#### *Applications/Needs*

Applications, or customer/market needs, determine drivers for the roadmap. Drivers are usually of the following types: “Do more,” “do for less,” “do new things,” “do enabling things.” Applications are often expressed in grand challenges for the field. Two prime examples are the Grand Challenges for the U.S. National Nanotechnology Initiative (NNI, 2003) and the Grand Challenges in Global Health defined by the Foundation for NIH in October, 2003 (FNIH, 2003). Table 2 lists the main NNI challenges and the global health goals with related challenges.

#### *Architecture*

Architecture defines how the pieces of the problem fit together. The architectural elements become the framework for the technology roadmap and help determine the priorities of work to achieve the roadmap’s objective. An architecture for roadmapping convergence was suggested by discussion at the Commercializing and Managing the Converging New Technologies workshop described in Appendix 2 of this book and is shown in Figure 2.

#### *Growth Trends*

Identification of long-term, sustained growth trends is central to understanding which inventions can become innovations. Trends in enabling technology result in continued declining costs for technology applications and increasing sophistication of applications.

Declining costs of technology allow increasingly complex applications. These trends have been apparent in information technology for more than 40 years. For example, computing power has exhibited exponential growth that began in the 1940s and continues at the present (Albright, 2002b).

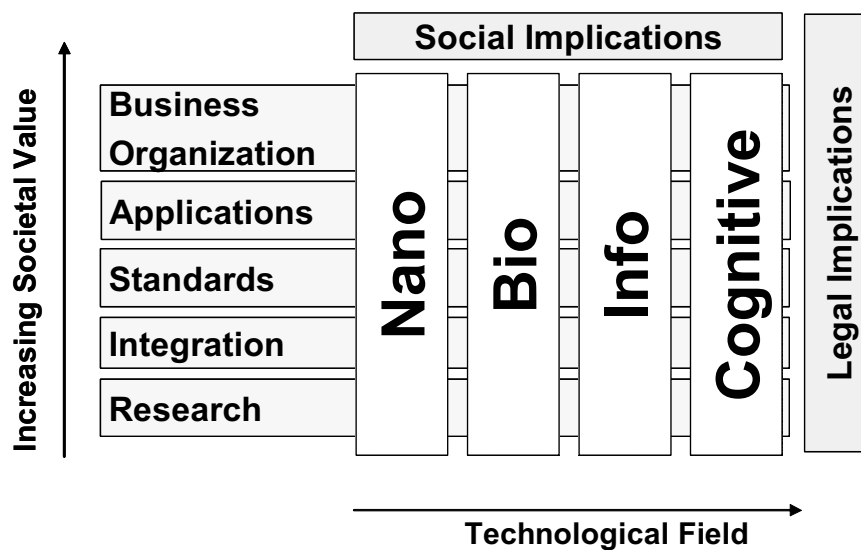

**Table 2: Grand Challenges for Nanotechnology and Global Health**

<b>NNI Grand Challenges (2001)</b>	<b>Nano</b>	<b>Bio</b>	<b>Info</b>	<b>Cogno</b>
Nanostructured materials “by design”	X			
Nanoelectronics, optoelectronics, magnetics	X		X	
Advanced health care, therapeutics, diagnostics	X	X		X
Nanoscale processes for environmental improvement	X			
Efficient energy conversion and storage	X		X	
Microcraft and robotics	X		X	
Nanoscale instrumentation and metrology	X		X	
Manufacturing at the nanoscale	X			
Nanostructures for chemical, biological, radiological, explosive detection and protection	X	X	X	
<b>Grand Challenges: Foundation for NIH (2003)</b>				
To improve childhood vaccines:				
Single-dose vaccines, effective soon after birth	X	X		
Vaccines that do not require refrigeration	X	X		
Needle-free delivery systems for vaccines	X	X		
To create new vaccines:				
Devise reliable tests in model systems to evaluate live attenuated vaccines		X	X	
Antigens for effective, protective immunity	X	X	X	
Learn which immunological responses provide protective immunity		X	X	
To control insects that transmit agents of disease:				
Genetic strategy to deplete or incapacitate a disease-transmitting insect population		X	X	
Chemical strategy to deplete or incapacitate a disease-transmitting insect population	X	X		
To improve nutrition to promote health:				
Create a full range of optimal, bioavailable nutrients in a single staple plant species		X	X	
To improve drug treatment of infectious diseases:				
Drugs and delivery systems that minimize the likelihood of drug resistant micro-organisms	X	X		
To cure latent and chronic infections:				
Create therapies that can cure latent infections	X	X	X	
Create immunological methods that can cure chronic infections	X	X	X	
Measure disease and health status accurately and economically in developing countries:				
Develop technologies that permit quantitative assessment of population health status		X	X	
Create technologies to assess individuals for multiple conditions or pathogens at point of care		X	X	X

Declining semiconductor costs enable applications using greater amounts of stored data and more complex algorithms for processing. For example, steady increases in the abilities of chess-playing computers tracked the advances of the fastest computers of the day to the point that computers now compete at the highest level. Voice processing, a complex processing challenge, is becoming practical in compact, often portable electronics with the use of low-cost memory and digital signal processing. Lower-cost electronic processing is also replacing mechanical functions in automobiles and other large equipment.

Figure 2. Architecture for Convergent Technologies



Information technology trends are well established and are widely tracked and used for forecasting. The 10-year forecast of needed capabilities of the International Technology Roadmap for Semiconductors is updated every 2 years. Many of the same information-enabling technologies will apply to fabrication of nanoscale devices, although we must look for new exponential power and cost trends. In biotechnology, the exponentially declining cost of genetic sequencing has been active for about 10 years and appears to have many more decades of improvement. Semiconductor technology is also a driver for genetic analysis as chips for DNA and protein analysis are developed.

Cognitive science is the most problematic of convergence areas where trends are concerned. The problems of cognitive and brain science are ones of how to accomplish goals – understanding the processes that are taking place – rather than the speed or number of steps. For example, the promise of artificial intelligence has not been advanced to the extent hoped by increased

processing power. Results are more a function of algorithms and understanding of complex cognitive skills.

#### *Positive Innovation Loop*

Lower capital requirements allow more people to use the technologies for innovation. The lower costs of enabling technologies allow more people to be involved and to collaborate in new ways. This positive innovation loop is shown in Figure 3 (Albright, 2002b). The innovations of many technology start-up corporations are possible because of lower costs and reduced financial risks. The open source movement in software development that emerged in the 1990s has been enabled by the low-cost, widely available global communications of the Internet; low-cost powerful computers; and widely available software – allowing rapid contributions to innovative software systems and rapid application and improvement by many individuals.

#### **Moving Forward**

To prepare to move ahead with roadmapping for converging technologies, teams should work in three areas, defining applications and related technology areas, identifying trends, and refining architectures.

An important next step toward creating roadmaps for converging technologies is the identification of areas in which there is important interaction among the fields. An example based on the application sets presented earlier is shown in Table 2. In the table, the four NBIC technology convergence fields are mapped to applications (challenges), showing where the intersections and enabler will likely be found. The technology fields could be further segmented, and the applications could be further filled out. The technology segmentation could form the basis of an architecture for a set of technology roadmaps that show how the applications can be implemented.

A systematic analysis of trend areas can begin with information technology, where the trends are well understood, and then move into nanotechnology and biotechnology trends.

With supporting information developed, a roadmapping team can define the scope of the roadmap they seek to create along with a set of objectives. They then can develop a roadmap to realize their objectives.

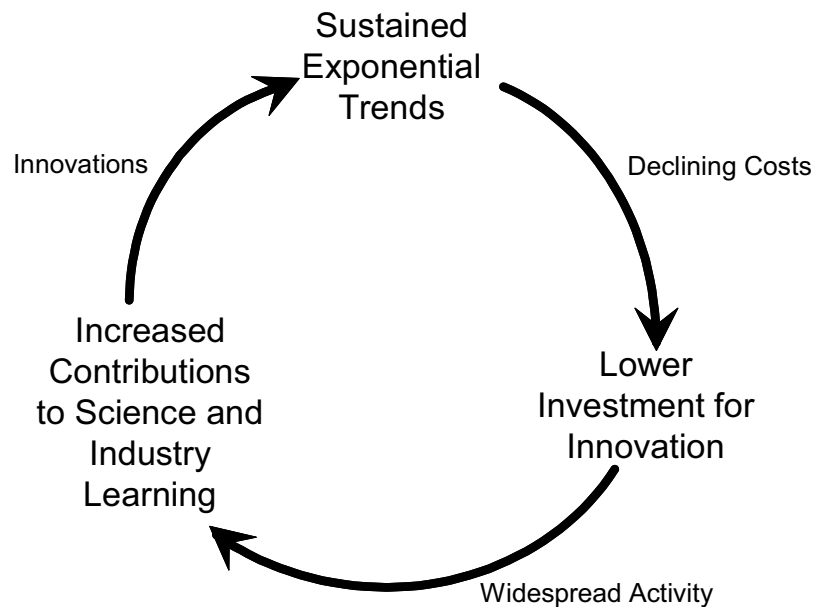
**Figure 3. The Positive Innovation Loop****References**

- Albright, R. E. 2002a. Roadmapping for global platform products. *Product Development and Management Association Visions Magazine* 26(4): 19–22.
- Albright, R. E. 2002b. What can past technology forecasts tell us about the future? *Technological Forecasting and Social Change* 69(5): 443–464.
- Albright, R. E., et al. 2003. Technology roadmapping. *Research and Technology Management* 46(2): 26–59.
- Foundation for the National Institutes of Health. 2003. *Grand Challenges in Global Health initiative*. Foundation for the National Institutes of Health, [www.grandchallengesgh.org](http://www.grandchallengesgh.org).
- Kappel, T. A. 2001. Perspectives on roadmaps: How organizations talk about the future. *Journal of Product Innovation Management* 18(1): 39–50.
- Kostoff, R. N., and R. R. Schaller. 2001. Science and Technology Roadmaps. *IEEE Transactions on Engineering Management* 48(2): 132–143.
- NNI. 2003. *Research and Development Supporting the Next Industrial Revolution*. Supplement to the President's FY 2004 Budget. National Nanotechnology Initiative, [www.nano.gov](http://www.nano.gov).
- Phaal, R., C. J. P. Farrukh, and D. R. Probert. 2001. *Fast Start Technology Roadmapping*. International Association for Management of Technology, [www.iamot.org/paperarchive/GSTBB.PDF](http://www.iamot.org/paperarchive/GSTBB.PDF).
- Willyard, C. H., and C. W. McClees. 1987. Motorola's technology roadmap process. *Research Management* 30(5): 13–19.

## **4. NBIC CONVERGENT TECHNOLOGIES AND THE INNOVATION ECONOMY: CHALLENGES AND OPPORTUNITIES FOR THE 21ST CENTURY**

*James Canton, Institute for Global Futures*

*Abstract:* Nano-Bio-IT-Cogno (NBIC) convergence offers both challenges and opportunities for the future of science, industry, and society. NBIC convergent technologies represent a new integrated framework for considering not just how science might be conceptualized but also how socioeconomics might be viewed differently. NBIC convergence is further evidence of an emerging Innovation Economy, where innovation tools, systems, products, and services become the dominant basis for commerce. Economic opportunities generated by NBIC may also improve quality-of-life factors in society. This chapter considers some of the evolving policy, business, and science implications of NBIC as we grapple with the vexing challenges associated with this Innovation Economy. In addition, as-yet-unresolved critical areas of concern – such as access to sustainable energy and health care, both of which are essential to quality of life, business and U.S. global leadership – may be furthered by NBIC convergence. Although NBIC is in the early stages of discovery, relevance of this new holistic model for solving global problems is appealing. The NBIC model holds significant promise in shaping the future development of human potential and fostering appropriate human enhancement. The hope is that NBIC may effectively accelerate the resolution of grand challenges that confront us today and as we move into the 21st century.

### **Forecasting the Future of NBIC**

How should we consider the future of NBIC? Are the innovations that will extend life and health and increase performance part of a new era of human enhancement? Can we discover new sources of energy to improve the quality of life for all? Can industry look to NBIC inventions to accelerate productivity and commerce? The promise is large, and the potential is unlimited. Forecasting the future of NBIC is a daunting challenge, but here is a collection of innovations that may come to pass as we unlock this potential:

- 100,000 machines generating energy from the solar cells that can all fit on the head of a pin
- Autos that are constantly recharging themselves, grown from nano-bio foundries

- A medical device that produces and dispenses drugs from the host body
- Supercomputers the size of a cell, in every human body, promoting health and preventing disease
- A hydrogen-based energy grid generating abundant clean, renewable energy for the community
- An Internet-based electronic commodities trading market that trades alternative energy credits
- Supply chains that are real-time linked invention powerhouses that globally connect producers to consumers for the on-demand ordering of any “idea product” any time.

Some of these forecasts may seem unrealistic, but I challenge all to consider the radically fast pace of innovation development we have witnessed in the past few years. Science and technology, the basis for all breakthrough innovations, have accelerated to a rapid pace over the past 25 years on a scale no civilization has ever experienced in the history of the world. The Internet was developed rather recently. The human genome has just been mapped. Embedded onboard computers that are wearable are just now available. Ten years ago we did not know what a stem cell was. Today, advanced technology, from IT to biotech and nanotech, are mainstream innovations quickly moving into the marketplace.

It is not hard to speculate about forecasts of smarter, smaller, faster, and more utilitarian products being invented in faster development cycles offering vast new power and a multitude of new capacities many more times what we have access to today. NBIC convergence is one example of this fast evolution of technology.

The central question will remain: Can we use NBIC convergence and evolution to resolve the grand challenges and the big problems that we either face today or will face in the future? This is the authentic challenge we need to meet to create sustainable and prosperous societies, industries, and economies. This should be the greatest challenge every leader in government and industry must be concerned about and working towards resolving every day.

NBIC researchers, using a unified approach for developing entirely new smarter and more intelligent products, could leverage from each of the specific attributes of each of the disciplines to create new combinations with complementary value. In other words, nanoscience using the entire NBIC tool kit might be applied to producing solutions to problems faster and more effectively than we do today, as we are too often dominated by silo thinking, silo education, and silo research and development.

For example, nanoscience representing the reduction of materials that might function on the nanoscale, combined with the organic biomimetic

functions that bioscience brings, matched with the information processing and *in silico* modeling contributed by information technology, and finally enabled by cognitive science insight into brain function might bring a new scientific breakthrough that would improve the human condition. If we had focused on only one science, we would have not been able to achieve a breakthrough.

### **Toward a Systems Approach**

What we too often have today is silo thinking in science, as in business and policy development, which offers too little a systems approach to conceptualizing a big enough “big picture” so we may: 1) Understand the larger interdependent, systems-wide factors that create large-scale problems (e.g., energy and health care), and 2) Invent systems-wide solutions that can address these larger problems. Silo thinking has of late, in the business community, come under attack because of the emergence of the connected enterprise that must break down the walls of unawareness. In the business world, silo thinking results in loss of market share, as well as loss of customers and business failure. Customer loyalty and purchasing are the litmus test for business performance and often survival. There is a high price to pay for the inability to change or the lack of innovation found in products and services, both of which are artifacts of the silo thinking of organizations (and people, especially leaders), and that is business failure. The incentives that drive private-sector innovation are real-time, unforgiving, and essentially Darwinian – survival of the smartest.

The life-and-death struggle of corporations is a fast test bed of the need for systems-wide thinking and action, as it is becoming common knowledge that silo thinking in business is the recipe for death. Business ecosystems may be better environments in which to study the need to reduce and eliminate silo thinking than those in science, in which the rigors of survival do not occur in as fast evolutionary cycles. The pressures of a business to generate profits and become sustainable, generating a return on investment, are always a real-time phenomenon. Few scientific organizations suffer the same fate.

The inability of organizations to change, evolve, and adapt is a dominant aspect of today’s modern global corporation. The opposite of these phenomena is the capacity for fast change, adaptation, and a systems-wide transparent connected enterprise. The fact that business corporations are vastly different from scientific organizations is less relevant here than how organizations, for profit or not, enable innovation in the culture and use innovation to sustain their survival.

Turning back to NBIC, a conceptualization of new holistic product families with enhanced functionalities may provide insight into what

directions toward which we might aspire. The NBIC challenge is to consider entirely new ways to think about problems and, employing the tool set of NBIC, to create entirely new solutions. New NBIC products may combine the unique characteristics of many of the parts, such as

- Self-assembly of cognitive medical devices at the nanoscale that enhance memory
- Biometric-sensitive communications that provide security
- Personalized genomic-pharma solutions that use our brains as drug factories
- Nanoscale engines that clean the environment of pollution and threatening bioagents
- Biosolar cells that generate energy from the sun and distribute energy over personal grids.

#### **NBIC's Grand Challenges of the Future**

There are many problems that even an advanced civilization such as ours has been unable to resolve that go to the core of what technology can accomplish in a given time on a global scale. With little hubris, we can safely say that innovation has delivered much new value to improve society. Although we have used innovations to dramatically improve agriculture yields, poverty and hunger still persist on a global scale. Whereas we have perfected the extraction of carbon-based fuels such as oil and gas, much of the world does not enjoy the same benefits as does the West. Although we have marvelous innovations in telecommunications, still only a fraction of the global population has access to the Internet or even to basic telephone communications, let alone the productivity gross domestic product (GDP) boost from information technology that every growing economy needs. I suspect that high teledensity penetration in the population is linked to increased productivity.

Is there a potential that the convergence of key NBIC technologies could alleviate some of these problems and accelerate people's access to sustainable energy, abundant food, and pervasive communications? The social risks associated with not furthering the use of NBIC in sharing the wealth of innovations may destabilize global security in the future. The risks are too high. At the same time, there may be greater opportunities to stabilize regions that have a potential for conflict by providing access to a higher quality of life for the population. NBIC may play a vital role in normalizing markets, communications, and access to commodities and services (health care and energy) that are essential to a better way of life. It should be in the interests of all policy makers to move towards this realization.



Certainly, innovation and the infrastructure of innovation – education, government, private-sector, and capital markets – have been key drivers of U.S. GDP success. I forecast that NBIC investments by the United States and other nations should continue to create robust markets and economies with accelerated GDP and productivity.

This is an important variable in the equation of what is the return on investment of innovations (innovation ROI) such as NBIC. Certainly, a nation that can provide for its citizens food, energy, and a prosperous economy is a strategic objective worth pursuing, but it is not enough. Governments as enablers of quality of life can do just so much. Investments in startup companies by robust capital markets such as venture capitalists also play an important role. Investments in education, energy, commerce, industry, and health care will produce a national ROI, but the investment in new innovations will have a widespread impact across all industries, as is the case in the United States and other countries.

### **The Innovation Economy**

Is it possible to invest in technology that will grow GDP of a region – or even a nation? Clearly, innovations are the key drivers of the GDP. In the United States, over one-third of the GDP is attributed to innovation. We are entering an era I call the Innovation Economy. It is a global shift in the basic economics of work, trade, and commerce, and it is a shift in the ways products and services are made and sold, and in how markets function.

Innovations – represented by the knowledge-based, high-volume services and products that are emerging all around us – are evidence of the Innovation Economy. Innovation comes in many forms. It may be a product like a cell phone, a new drug, or a material stronger than steel. It may be a service that does drug discovery on-demand in China, or a South Dakota call center that services a business in India. Whereas hard commodities such as oil, steel, and coal were the building blocks of the last economy, the new economy will be based on innovation. And the key innovations will be NBIC. Why? The new economic building blocks are bits, genes, atoms, and neurons, as shown in Figure 1.

These are the ingredients of the Innovation Economy: knowledge products. Those that achieve primacy via intelligence, adaptation, and connectivity will define the Innovation Economy of the future. Here's how NBIC fits into the Innovation Economy:

- Nanotech: The on-demand design of matter at the atomic scale will redefine the future of making things; materials science is in flux; everything from supply chains to manufacturing to health care to energy will shift.

**Figure 1. The Building Blocks of NBIC**

- IT: Represents perhaps the most mature of the NBIC technologies in that IT is the enabler – the tool to simulate, to compute, to analyze, to store, and to process the information about the innovation.
- Bioscience: The unlocking of the genome, the understanding of life processes for new drug discovery, disease prevention, and agriculture has already produced impressive breakthroughs.
- Cognitive science: The most immature of the NBIC four horses and the one about which we know the least, cognitive science is so profoundly important: understanding the workings of the brain.

Alone, each of these NBIC innovations holds impressive potential for seizing the mantle of innovation leadership, but together, as an interdisciplinary yet unified model, NBIC holds even greater potential to

- Accelerate discovery and invention
- Produce abundant cost-effective high-yield products
- Increase the capacity of humans to enhance their human potential
- Offer new tools to maximize efficiencies
- Gain access to new markets
- Increase quality of life
- Enhance human performance and learning worldwide
- Establish a competitive advantage for businesses and nations

### **NBIC and the Energy Future**

Energy is the currency of the world. It is the single most important commodity that affects security, poverty, peace, commerce, and quality of life. Without access to energy, economic development is slow, and quality

of life is low. A population's access to energy for industrialization may be the defining aspect of socioeconomic productivity, for without the access to energy, there is little prospect for growth. Even industrialized nations such as Japan and the United States suffer from their dependency on energy to grow and sustain economic prosperity.

Energy is geostrategic and essential to the future of every nation. I forecast that the geostrategic value of energy will become even more vital and a source of global insecurity, as nations struggle over access to energy where demand issues outpace supply. In our forecasts of China's energy needs over the next 50 years compared against the declining oil reserves – the primary source of energy on which nations rely – it is probable that conflicts will arise over a keen competition for dwindling resources.

A nation's access to energy is directly related to its capacity to achieve a high Gross Domestic Product. For example, the United States and the European Union are growing at about 3% GDP each. China is growing at about 10%. In order to sustain and grow, more than three times the energy used by the United States will be needed on a massive scale in China. This example is consistent across many nations, especially those on the path of the Innovation Economy, such as India, Thailand, Korea, Malaysia, Chile, Brazil, Russia, and the other former Soviet Republics, to name a few.

There are few examples in which the impact of NBIC technologies, in part or together, could have a more positive impact on society and the economy than with energy. It has become apparent that access to energy drives most issues affecting socioeconomics and quality of life around the world. Energy, as a vital commodity of the Innovation Economy, is essential to a growing population, whose demand may outpace supply unless we invest in new development sources. The West gets most of its energy from oil.

It is generally accepted that the prosperity of a nation may be measured by its per capita GDP, which is correlated with its per capita energy consumption. Over the past 30 years, U.S. GDP per capita has doubled, whereas energy use has remained constant, according to the U.S. Department of Energy, Energy Information Administration. But this is not the case in the rest of the world, which cannot benefit from this energy efficiency model because other nations do not as yet have the same access and wealth to reach this level of energy acquisition.

Most population forecasts indicate that by 2050 there will be over 10 billion people on the planet. We are using about 12 Terawatts (TW) of energy worldwide today; this is about 150 million barrels of oil (MBO) a day. By 2050, we will need about 30 TW, or the equivalent of 450 MBO. In order to generate this kind of energy increase, we will need to rely on renewable energy sources such as solar, geothermal and hydrogen, that are not feasible today because of cost or lack of efficiency innovation. Oil reserves cannot fully satisfy the energy demand expected in the future – we

simply cannot count on an unlimited supply of oil in the future. Investment in new innovations to replace carbon-based energy is one of the most critical objectives of this decade.

Nanoscience, particularly nanomaterials, could possibly enable the formulation of sustainable, clean, and renewable energy that would be the single major breakthrough that would invigorate the global economy and enhance quality of life. Significant investments in the public and private sector – ranging in the billions – will be needed to meet this objective. NBIC technologies may play a part in this future.

In a June 2004 conference organized by the U.S. Department of Energy (the first Nanoscience Summit), Dr. Richard Smalley, the Nobel Prize winner in nanoscience, expressed his deep concerns about how important energy was to the future of the planet's security and sustainability.<sup>1</sup> He reminded us that there are probably declining oil reserves and that we cannot assume blindly that affordable energy will be provided by oil forever. We must explore new alternatives to plan for an energy-hungry world in the future.

NBIC innovations, shaped by the dramatic increase in energy demand by 2050, with a growing population of 10 billion, could provide a breakthrough in the following efficiencies:

- The development of a hydrogen fuel cell for transportation
- The development of a nano-energy and a global infrastructure of renewable sources such as solar, geothermal, wind, and hydrogen
- The development of a nano-bio solar cell for batteries
- A new type of energy grid that is adaptive, network based, and tied to sustainable energy sources
- Photovoltaics and diodes as new sources for fuel-efficient lighting and energy
- Clean coal extraction and deployment.

The world needs access to over 30 TW of clean, renewable, and carbon-free energy sources by 2050. I forecast that the global level of socioeconomic crises, without this energy, will put geostrategic security at risk. Conflicts between nations and regions over energy, and the subsequent benefits that come with energy access such as increased GDP, will be common if this issue is not resolved. Geostability – the conflict-free mobility of markets, people, and commerce – will be based on who gets access to energy and where. Without planning today for building massive solutions for producing

---

<sup>1</sup> Department of Energy, NanoEnergy Summit, June 23–24, 2004, [public.ornl.gov/conf/nanosummit2004/](http://public.ornl.gov/conf/nanosummit2004/); Dr. Richard Smalley, Web site, [smalley.rice.edu/](http://smalley.rice.edu/).

more energy – 10 TW more at least by 2025 – the risk of global or regional conflict increases.

It is in the interest of all scientists that NBIC innovations be used to improve the standards of living of all people. Energy is clearly one area that is a common need and a resource that is consumed by all people on the planet regardless of geography. It is becoming clearer that we cannot achieve 30 TW of energy by 2050, or before, with a fraction of that output, without huge investments in R&D to prepare for a post-oil world. We cannot wait to discover the actual oil reserves that lie in the OPEC countries: It is questionable that the estimated reserves are even there at the levels being reported by the host countries and OPEC.

To further this effort, the new nanomaterials centers being constructed by the U.S. Department of Energy are the beginning of an insightful effort to use nanotech as a first step in developing new innovations for energy. This is one convergence example that we need to build on, as the future looms closer with challenges such as energy access and GDP held in the balance. Can we use NBIC innovations to create new energy breakthroughs? We must, if we are to have a clear path towards peace and prosperity in the 21st century.

### **NBIC and the Future of Health Care**

If energy is one priority area essential to our quality of life, than health care must be on this list as well. Health care will be reshaped in fundamental ways, given the demographics of the aging “baby boomers” and the innovations in the human genome that are just now emerging. Nano-Bio innovations are close at hand, as are medical devices that will need to be built at the nanoscale to perform “invisible functionality.”

The problem with much of health care is that many innovations cost more, increasing the overall expenditures in health, and driving up consumer prices that are already out of control. A few years ago, a bee sting requiring a shot of cortisone at the local emergency room cost \$50. Today, that same shot at the same local hospital costs \$300. This expense, in turn, is trivial compared to the unbridled costs in health care and a system that lacks any incentive to change or reduce costs of care. Health care is unsustainable as a system in the United States, yet there is little political willpower to make a change.

Health care is a dysfunctional train wreck that everyone relies on, and yet everyone complains about. As the largest industry in the United States, standing at over \$1.7 trillion, health care continues to explode out of control. It is an escalating cost nightmare that we forecast to grow to over \$2.3 trillion by 2008. It is unsustainable – out of control – yet everyone needs health care, so little is done to make significant changes to the model.

Nevertheless, 76 million baby boomers, ever aware of their \$44 trillion in spending power, will redefine health care, making it more longevity-oriented and based on life extension, health enhancement, and post-geriatrics. Perhaps they will also force the dollar issue, reducing costs in their own self-interest, as there is so little political will or private sector incentive to “make less money and reduce waste.”

NBIC will find a friend in the boomers who want to live longer and stay active, redefining aging in the process – of course, for the right price. NBIC innovations will be tested on the boomers and then rolled out with lower price points to all the generations after them, generations X, Y, and the millennial.

**Figure 2. The Future of Health Care**



Boomers will set the new gold standard of care and aging, redefining health care, and NBIC will lead the way, transforming health care, paving the way for future generations that will emulate the boomers’ values, behaviors, and desires for longevity and enhancement as the new focus for health care.

As we migrate towards a post-genomic society in which the bounty of personalized genomic informatics becomes a key driver of more effective and customized care, NBIC technologies have a role to play by offering cost-effective innovations. We need to consider cost-effectiveness without reducing the quality of care, as we examine new innovations in health care. Clearly, NBIC holds the promise of giving us greater capabilities to heal and restore human facilities, and maybe enhance human performance. There needs to be a new social consensus on reformatting health care where cost reduction, appropriate enhancement, and quality go hand-in-hand. Eventually – not immediately – I forecast NBIC innovations can make a positive impact, if focused on enhancing health care performance.

A new directorate will be needed for the nation, focusing on redefining health care, given innovations such as NBIC – perhaps it will be called Health Enhancement and Prevention. Having worked in health policy at the federal level, I know that attempts in the past to shift the model of health care have been too small. The Office of Health Promotion and Disease Prevention, which I advised in the 1970s, had great promise, backed by solid science data, but had little support for changing medicine.

### **Appropriate Human Enhancement and Human Rights**

The appropriate enhancement of human performance will be viewed as a right in a democratic society. Who would argue that one should not desire enhancements, if the means were available to live longer, to have a memory restored, or to achieve mobility? I maintain that NBIC will be used to enhance intelligence, mobility, cognitive qualities, and even vision and hearing for certain careers or desires. I think we will stop short of eugenics but proceed to offer neurological and physical enhancements that improve the quality of life under the umbrella of medicine. Industry is watching this debate closely. Boomers are also watching this debate and will influence the outcome, based on their health economic investments.

Do people in a free society have the right to enhance their memory, augment their intelligence, maximize their pleasure, and even change their physical forms on demand? This will become a human rights issue in the 21st century. This era of Post-Humanist Health Care will be accelerated by NBIC advocates who mean well and offer a new “look” on life, just as the plastic surgeons or therapists offer today. I forecast that directed evolution within many parameters hard even to hypothesize will become available with NBIC. Longevity medicine, life extension, and the augmentation of human performance will become features of our global culture in the near future.

This will frustrate some, and others will celebrate NBIC democracy. As we battle over the right to life, we will battle in the future over the right to personal enhancement. Radical choices will be offered to families who want certain characteristics in their children yet to be born, such as genetic augmentation of intelligence and preferred physical attributes. In other words, with human nature being what it is, improvement and enhancement of human performance will become a product offering in the global marketplace. This has already begun.

The choices we make, as policy makers and scientists, will be essential to the ethical and democratic futures of NBIC as well as the practical use of NBIC. We must be concerned with appropriate and legitimate solutions in a global free-market system that has become accustomed to the search for personal improvement. At the same time, NBIC democracy will be hailed by many as their right in a free society to change themselves, given no harm to

others. No doubt this will become a feature of the Innovation Economy of the 21st century as we struggle with the limits and laws that will certainly impact our society, our evolution, and our civilization.

### **Summary**

NBIC technologies may come to offer many new choices to society, but if NBIC is to be relevant, then innovations that offer cost-effectiveness, provide quality of service, and enable access to resources (with health care and energy as examples) are important markers of relevance. At the same time, NBIC will play a role in redefining health care and perhaps will contribute to providing access to other resources such as energy.

The Innovation Economy is coming. I forecast that over two-thirds of American GDP will be contributed by innovation products and services. The rest of the world will follow suit. Nanoscience investments by other governments and the private sector now eclipse those by the United States Government, which led the way initially. As we forge a new interdisciplinary model of science, illustrated by NBIC, perhaps we can prevent the geostrategic crises in energy and health care that will threaten to destabilize peace and security in the future.

This is not to pretend that NBIC will be a new magic bullet, able to bridge the gap between the haves and have-nots, or be the slayer of social inequality. NBIC innovations will create a new set of tools, products, and solutions, as well as whole new industries. If we focus the NBIC resources on enhancing human performance and developing human potential, then we might provide new solutions to the challenges we will most certainly face in the future. It would be for the good that the nation that won the Cold War, that is the last of the true superpowers, to take the lead in using science to plan for a more sustainable, peaceful, and secure future for all. This is a future in which the rights of individuals to make free choices must be the gold standard of every society. If dictators or rogue private interests are allowed to subvert these NBIC technologies, disaster could well be the outcome and threaten the free world.

NBIC technologies are in the vanguard of this Innovation Economy, offering a new paradigm of discovery. This paradigm recognizes that the problems we face today and will face in the future require a more integrated interdisciplinary solution to better manage global crises and challenges. This is the challenge before us as we map the future of NBIC. Economic prosperity, security, and quality of life can be geostrategic goals we focus the tool set of NBIC to address, if leaders will heed the call and rise to meet the challenge.



**References**

- Berger, P., and S. Huntington. 2002. *Many Globalizations*. N.Y.: Oxford University.
- Canton, J. 1999. *Technofutures*. Carlsbad, Calif.: Hay House.
- Christensen, C. 2000. *The Innovator's Dilemma*. New York: HarperBusiness.
- Goldstein, D. 2004. *Out of Gas*. New York: W.W. Norton.
- Kelley, T. 2001. *The Art of Innovation*. New York: Currency/Doubleday.
- Lovins, A. 2003. Twenty hydrogen myths. [www.rmi.org/images/other/Energy/E03-05\\_20HydrogenMyths.pdf](http://www.rmi.org/images/other/Energy/E03-05_20HydrogenMyths.pdf).
- Malone, T. W. 2004. *Future of Work*. Boston: Harvard Business School Press.
- Office of Science. 2003. *Basic Research Needs for the Hydrogen Economy*. Washington, D.C.: U.S. Department of Energy, [www.sc.doe.gov/bes/hydrogen.pdf](http://www.sc.doe.gov/bes/hydrogen.pdf).
- Rifkin, J. 2002. *The Hydrogen Economy*. New York: J. P. Tarcher.

## 5. MEASURING THE MERGER: EXAMINING THE ONSET OF CONVERGING TECHNOLOGIES

*Evan S. Michelson, George Washington University*

*Abstract:* This chapter describes some of the key indicators and metrics that support the conjecture of convergence. It first provides a general description of what is meant by converging technologies, then points toward some specific examples indicating that this convergence is already beginning to occur. Indicators that can be used to detail how the process of convergence occurs are government spending, university programs, inter-firm strategic alliances, intra-firm technological expansion, and patent citations. The chapter concludes with policy recommendations.

### Introduction

One of the most integral and necessary aspects of determining how to distribute resources and implement public policy decisions is understanding the trends and factors that will come to act as key drivers over the course of the long-term future. Specifically, this kind of foresight is quite useful and valuable in the realm of science and technology, where the transition from basic discovery to applied research to product manufacturing can take years, and where new developments are emerging at an ever-increasing and rapid rate. Recently, a number of science and technology forecasts have begun to identify one such development that has the potential to radically reconfigure the landscape of innovation: the coming and ongoing convergence of different technologies. As different scientific disciplines and their associated technologies have begun to emerge, progress, and mature over the past few years, there has been an increasing tendency for such strands of thinking to intersect and cross-pollinate with one another, thereby creating the potential for a great improvement in the quality of human life.

This attempt to measure the merger of technologies is not meant to categorize or codify every single instance of convergence. Instead, the point is to describe a series of variables that sketch an outline of where to look for and how to gauge the true nature of such convergence. Moreover, the very fact that the notion of “converging technologies” covers a wide intellectual space implies that one must hold and cast a broad view over a variety of subjects in an attempt to understand how these tendencies are taking hold in a multiplicity of science and technology domains.

Three primary sources help provide the context and background for the subsequent discussions. The first is a foundational report, sponsored by the National Science Foundation (NSF) and the Department of Commerce (DOC), entitled *Converging Technologies for Improving Human*

*Performance*; the second is a more recent report, released in 2004 by the Science and Technology Foresight Unit of the European Union (EU), entitled *Converging Technologies – Shaping the Future of European Societies* (Nordmann, 2004); and the third is a more critical report, released by the Action Group on Erosion, Technology, and Concentration (ETC), entitled *The Big Down: From Genomes to Atoms* (ETC Group, 2003).

Again, the point here is to provide and specify a cluster of instructive variables – supported by a number of examples – that will be organized into useful categories of analysis, categories that are robust enough to be continuously and repeatedly applied as this trend progresses over time. At the end, I will lay out a series of policy recommendations that could be implemented to fill in the gaps that currently exist and to assist in providing additional measures that are capable of illuminating additional facets of the converging technology phenomenon. In short, this integrated plan of action is an attempt to identify ways that will overcome some of the major barriers that currently hinder a more comprehensive and widespread understanding of converging technologies. Overall, the hope is that by depicting some of main variables that are already demonstrating movement towards increased convergence, while simultaneously outlining some potential policy prospects that could help increase awareness of this process, this analysis will move the debate beyond an abstract conceptualization of converging technologies and into a more concrete and practical appreciation of how this trend has, and will continue, to come to pass.

### **The Fundamentals of Convergence: NBIC, CTEKS, and BANG**

In 2001, the National Science Foundation (NSF) and the Department of Commerce (DOC) sponsored a workshop that resulted in an extended report describing the potential of what it called “convergent technologies,” which it defined as “the synergistic combination of four major ‘NBIC’ (nano-bio-info-cogno) provinces of science and technology, each of which is progressing at a rapid rate” (Roco and Bainbridge, 2003: ix). The report described the merging and interplay between four key technologies – nanotechnology, biotechnology, information technology, and cognitive science – all of which have undergone significant changes, improvements, and expansion over the last half-century. As the report highlights, the driving force behind this kind of unification is that new scientific and technological paradigms are being developed that are, for the first time in human history, allowing for “a comprehensive understanding of the structure and behavior of matter from the nanoscale up to the most complex system yet discovered, the human brain” (Roco and Bainbridge, 2003: 1).

Moreover, the report drew attention to the fact that these new technologies are no longer merely progressing towards their own ends and goals. Instead,

both individually and in conjunction with one another, these technologies increasingly hold the promise of enhancing “both human performance and the nation’s productivity” in ways previously unimagined (Roco and Bainbridge, 2003: 1). For example, such convergence has led to the hope that, one day, engineered nano-sized devices could be used not only as medical diagnostic and therapeutic tools but as bio-computational processing structures in which massively connected and distributed information systems are linked together and directed towards improving human cognition and memory. It is because of these inviting and enticing scenarios, amongst others, that Sonia Miller, lawyer and founder of the Converging Technologies Bar Association, and Mihail Roco, the NSF’s Senior Advisor for Nanotechnology, concluded, “NBIC represents the multidisciplinary blending of science, engineering, technology, and medicine with the human dimension” (Miller and Roco, 2003: 1). The idea here, which is echoed as the underlying theme of the NSF/DOC report, is that these developments will not be limited or restricted to simply impacting science and technology. In fact, as Miller and Roco astutely note, it is clear that “the issues converging technologies will raise cut across a wide swatch of important practice areas,” from “intellectual property law” to “corporate formation and partnership” to “technology transfer and commercialization” (Miller and Roco, 2003: 1).

Though the interface between these four fields of science and technology is growing ever more blurred and porous, I contend that the main driver underlying the imminence and prospects of converging technologies is the “N,” or nanotechnology, aspect of the relationship. The government-sponsored report appears to agree with this assertion by commenting that “convergence of diverse technologies is based on material unity at the nanoscale and on technology integration from that scale” (Roco and Bainbridge, 2003: 2). The point is that without the potential capability of manufacturing and manipulating matter at the nanometer scale, none of the other disciplinary interplays would be nearly as enticing, inviting, or appealing. A recent analysis of the subject by the ETC Group, a technology watchdog civil society organization based in Canada, points out that part of the reason why nanotechnology is so fundamental to this process of convergence is that “all matter – living and non-living – originates at the nano-scale. The impacts of technologies controlling this realm cannot be overestimated: control of nano-scale matter is control of nature’s elements” (ETC Group, 2003: 6). Along these lines, a report analyzing the risks and dangers of nanotechnology by the Risk Assessment Unit of the Health and Consumer Protection Directorate General of the European Commission supports this claim by stating that “nanotechnologies enable other technologies” and, because of their very ability to “connect disciplines as diverse as physics, chemistry, genetics, information and communication technologies (ICTs), and cognitive sciences, they offer the foundation of the

so-called nano-bio-info-cogno (NBIC) ‘convergence’” (Risk Assessment Unit, 2004: 13).

In addition to the foundational report supported by the NSF and DOC, a more recent analysis of converging technologies was undertaken by the EU as an attempt to take a first step beyond the initial conceptual investigation of convergence, all with a primary focus on providing a deeper understanding of how this phenomenon could be directed and implemented from a distinctly European perspective. When compared with the NSF/DOC version, this report offers a complementary definition of converging technologies as being “enabling technologies and knowledge systems that enable each other in the pursuit of a common goal” (Nordmann, 2004: 14). However, the High Level Expert Group (HLEG), which was responsible for undertaking this examination on behalf of the EU, also makes a point of describing and defining a more restricted and particular agenda for Europe with regards to converging technologies under the heading of Converging Technologies for the European Knowledge Society (CTEKS). Unlike the original, more open-ended, and unabashedly optimistic conceptualization of NBIC put forth by the original American report, CTEKS “prioritizes the setting of a particular goal for CT research” but also calls for “an awareness of their potential and limits” (Nordmann, 2004: 19). The aim of establishing the notion of CTEKS was to introduce the social sciences and the humanities as significant participants and players within the European approach, thereby allowing representatives from these fields a voice in setting the converging technology research agenda and determining the acceptable boundaries for inquiry. For this reason, the CTEKS version of converging technologies attempts to situate developments in nanotechnology, biotechnology, information technology, and cognitive science in explicit conjunction with the needs and requirements of other disciplines, such as ecology, geography, and sociology.

It should also be noted that, unlike the NSF/DOC and EU reports, which approach the subject of technological convergence with a mostly positive and hopeful mindset, there is the alternative conception, presented by the ETC Group, that takes care to warn about the consequences and dangers of allowing such technological developments to continue unfettered and unrestrained. For example, the ETC Group has adopted the acronym BANG to identify the main drivers of convergence – the bits associated with information technology, the atoms associated with nanotechnology, the neurons associated with cognitive science, and the genes associated with biotechnology – that they assert “will profoundly affect national economies, trade and livelihoods . . . in countries of both the North and the South” (ETC Group, 2004: 5). Although this cautionary attitude leads to the conclusion that the interaction of technologies has the potential to “allow human security and health – even cultural and genetic diversity – to be firmly in the hands of a convergent technocracy,” it does bring to light the very real worry that the

emergence of converging technologies will further exacerbate the disparities and discrepancies between the haves and have-nots of the world (ETC Group, 2004: 5). As I will discuss later, these concerns must be taken into account and addressed to ensure that the benefits of technological convergence come to outweigh its drawbacks.

Finally, it is clear that all three seminal reports offer suggestions and recommendations that are aimed at advancing their converging technology agendas, with the NSF/DOC and EU reports focusing on how to institutionalize research and development of converging technologies within their respective systems of innovation, and with the ETC report calling for wider public participation and involvement in discussions over the role that converging technologies should play in society. Along these lines, the NSF/DOC report recommends developing “a national R&D priority area on converging technologies focused on enhancing human performance” (Roco and Bainbridge, 2003: 24). Similarly, the EU report calls for implementing the Widening the Circles of Convergence (WiCC) initiative, which would “establish CTEKS within a limited time frame of 3 to 5 years as a thematic priority for European research primarily in the general areas of health, education, information and communication infrastructure, energy, and the environment” (Nordmann, 2004: 44). Clearly, the NSF/DOC and EU efforts of establishing converging technologies as a central priority within government are still in the incubation stages and, as per the viewpoint of the ETC Group, will require a number of “seed” workshops, planning committees, and public outreach to help marshal and garner support for any and all policy proposals. However, as I demonstrate in the next section, even without these large-scale national or regional investments directly aimed at fostering the convergence of different technologies, there are a number of indicators, from a variety of sectors and sources, demonstrating that technological convergence has already begun and will, most likely, continue to expand in the future.

### **Indicators of Convergence: Evidence of Technological Interaction**

In order to appreciate, recognize, and measure the growing trend towards convergence, I have outlined the following five different indicators, or metrics, which offer useful evidence that such movements have already started to occur: government spending, university programs, inter-firm strategic alliances, intra-firm expansion, and patent citations. The following framework provides a rough sketch of how technological convergence can be identified and quantified. The idea is to provide a starting point for thinking about how these indicators should be grouped and, subsequently, to offer suggestions that should guide future inquiries into the subject. In the future, it is clear that new kinds of examples will emerge with respect to the other

areas of convergence, and once they emerge, these instances will require sufficient attention in their own right. Moreover, as different technologies mature in interesting and novel ways, entirely new classes of indicators will arise, thereby depicting new kinds of phenomena that, in turn, will invite and require further evaluation and assessment.

### *Government Spending*

The first – and I would argue, major – indicator of convergence is the spending and allocation of funds by the government, particularly in the United States, for interdisciplinary programs, multidisciplinary projects, and inter-agency collaboration. Because the U.S. government is the predominant source of funding for basic research, understanding how it allocates resources with respect to science and technology is paramount, and therefore, only a close analysis of its budget allocations will be able to provide a deeper appreciation regarding the true nature and progression of converging technologies. For instance, one of the first major steps toward government support of converging technologies occurred on December 3, 2003, when the Congress passed the 21st Century Nanotechnology Research and Development Act, thereby stipulating nanotechnology, and all associated interdisciplinary research, as a science and technology priority for the nation. Along these lines, a supplementary budgetary account produced by the National Nanotechnology Initiative (NNI) – which oversees all U.S. government research and development on nanotechnology – points out that investments in nanotechnology have increased over the past year, for “as part of the FY 2004 Budget, President Bush requested \$849 million for nanotechnology R&D . . . this represents an increase of approximately 10% over the amount appropriated by Congress for FY 2003” (National Science and Technology Council, 2003). Moreover, as a statement by the Office of Science and Technology Policy indicates, this high-level of investment increased for FY 2005, as the president’s budget request for the NNI neared \$1 billion – a full-out doubling over 2001 funding levels.<sup>1</sup>

Along with this rise of government funding with respect to the NNI’s budget over the past few years, I argue there are three additional specific instances and programs that demonstrate the increasing desire of the U.S. government to harness and garner the benefits of technological convergence. The first and most illuminating case is the National Cancer Institute’s (NCI) decision on September 13, 2004, to support “a new \$144.3 million, five-year initiative to develop and apply nanotechnology to cancer.”<sup>2</sup> This project is the epitome of how different disciplines can mutually profit from the convergence of technologies, with research in nanotechnology being directly

---

<sup>1</sup> [www.ostp.gov/html/budget/2005/FY05NNI1-pager.pdf](http://www.ostp.gov/html/budget/2005/FY05NNI1-pager.pdf).

<sup>2</sup> [www.nci.nih.gov/newscenter/pressreleases/nanotechPressRelease](http://www.nci.nih.gov/newscenter/pressreleases/nanotechPressRelease).

aimed at discovering and curing the underlying causes of cancer. In order to carry out this project, the NCI “is forming the NCI Alliance for Nanotechnology in Cancer, a comprehensive, integrated initiative encompassing researchers, clinicians, and public and private organizations that have joined forces to develop and translate cancer-related nanotechnology research into clinical practice.” In order to accomplish this mission, the NCI released a thorough *Cancer Nanotechnology Plan*.<sup>1</sup> that outlines a number of cancer-related nanotechnology activities that will be carried out in the future, from the creation of numerous Centers of Cancer Nanotechnology Excellence, to the founding of a Nanotechnology Characterization Laboratory, to the support of various multidisciplinary research teams, all of which will share the same goal of applying insights from one scientific field to solve problems in another.

A similarly significant, though perhaps somewhat unexpected, site of technology convergence is occurring under the auspices of the U.S. Department of Agriculture (USDA). In a June 2003 special report, entitled *21st Century Agriculture: A Critical Role for Science and Technology*, the USDA highlighted nanotechnology as one of the key drivers of research in agriculture and food safety, all in an attempt to identify and exploit the potentials inherent in possible “nano-agri” convergences. In particular, this report highlights the fact that the merging of technology can “increase agricultural productivity, enhance the nutrient content of foods, and offer new capabilities and options in food and agriculture production and marketing.” Moreover, the report points out that developments in the field of bioinformatics – which links biology and computer science in order to generate computer-based statistical models related to the investigation of food quality, pharmaceutical safety, and the health impact of certain chemical compounds – should be acknowledged for their applicability in the agriculture sector, particularly in the facilitation of “international databases” that will help scientists assess “the quality of data on plants, animals, and microbes” (USDA, 2003: 24). In fact, it is this kind of “nano-agri-info” convergence that led the ETC Group to conclude that “in our molecular future, the farm will be a wide area biofactory that can be monitored and managed from a laptop and food will be crafted from designer substances delivering nutrients efficiently to the body” (ETC Group, 2004: 8). In other words, the improvements associated with the rise of technological convergence will provide biologists, farmers, and policymakers with better opportunities to investigate the physiology and environment of plants and animals, all in an attempt to raise productivity and improve efficiency.

A final instance of government participation in support of converging technologies is the National Health Information Infrastructure (NHII)

---

<sup>1</sup> [nano.cancer.gov/alliance\\_cancer\\_nanotechnology\\_plan.pdf](http://nano.cancer.gov/alliance_cancer_nanotechnology_plan.pdf)



program, which is an attempt to apply improved communication and information systems to health care. On July 21, 2004, NHII released an expanded “outline of a 10-year plan to build a national electronic health information infrastructure in the United States” (U.S. Department of Health and Human Services, 2004). The report, entitled *The Decade of Health Information Technology: Delivering Consumer-Centric and Information-Rich Health Care*, noted that health care and information technology should be employed in conjunction with one another to reduce errors, guarantee quality, and stimulate innovation. In particular, the report stipulated that the Agency for Healthcare Research and Quality (AHRQ), whose funding rose in the FY 2005 budget request to \$100 million, should move to create regional, state, and local grants for the application of information technology to health care. Much like the “nano-bio” convergence discussed with respect to the NCI’s cancer nanotechnology initiative and the “nano-agri” convergence discussed with respect to USDA’s report on technological innovation, NHII’s particular “bio-info” convergence will go a long way in increasing the power and scope of the respective converging technologies, which will simultaneously lead to the creation of new fields of study that will come to emerge over time.

#### *University Programs*

A second significant indicator is the rise of new multidisciplinary academic programs and departments that not only produce basic research but also grant degrees and encourage scholarly publication. In particular, the rise of numerous interdisciplinary programs, throughout the United States and abroad, over the past few years demonstrates that, at some level, convergence is beginning to become established in academic circles. Although a number of these programs focus on the “nano-bio” interface, there are a number of examples in which institutions have established programs at the “bio-info” nexus as well.<sup>1</sup>

For instance, institutions such as Cornell University, Rice University, the University of South Carolina, and the University of Washington all support degree-granting and tenure-track programs that link nanotechnology and biotechnology. One of the pioneers in this group was Cornell’s Nanobiotechnology Center (NBTC), which was founded in 2000 in an attempt to create an institution that would highlight the “interdisciplinary nature” of research and that would feature “a close collaboration between life scientists, physical scientists, and engineers.”<sup>2</sup> Currently, NBTC has done just that, by supporting a faculty of over 40 members from Cornell and other universities and by sponsoring programs with a focus on multidisciplinary

---

<sup>1</sup> [www.iscb.org/univ\\_programs/program\\_board.php](http://www.iscb.org/univ_programs/program_board.php).

<sup>2</sup> [www.nbtc.cornell.edu/](http://www.nbtc.cornell.edu/).

subjects, such as biomolecular devices and analysis, biomolecular dynamics, cellular microdynamics, cell-surface interactions, and nanoscale cell biology.

Similarly, Rice's Center for Biological and Environmental Nanotechnology (CBEN) undertakes research that not only addresses the "nano-bio" interface but also is concerned with the "nano-enviro" interface, at which nanotechnology begins to have either a positive or negative effect on the external environment. In short, CBEN not only works to "exploit the unique properties of nanomaterials to provide solutions for challenging bioengineering problems" but also works "to guarantee that nanotechnology emerges as a positive, powerful tool for improving our environment."<sup>1</sup> Along the same line, both the University of South Carolina's Nanoscience and Technology Studies Program (NSTS) and the University of Washington's Center for Nanotechnology (CNT) dedicate a significant portion of their programs to the nascent field of bionanotechnology. For example, South Carolina's NSTS program offers graduate and undergraduate coursework in nanomedicine and holds conferences on the human and biological impact of nanotechnology. Moreover, Washington's CNT supports a number of research groups that focus on "bio-inspired materials" and the creation of biologically compatible nanosystems. In short, all three of these programs, along with Cornell's, are at the forefront of a trend in academia that, I contend, will redefine the landscape of university research, as an increasing number of programs are designed to straddle the boundaries of different technologies and fields of scientific study.

In addition, a host of programs have been developed over the past 5 years that take a strong interest in the intersection between biology and information technology, the so-called "bio-info" interface. Programs at Stanford University,<sup>2</sup> Boston University, the University of Michigan, the University of California at San Diego, and Georgia Institute of Technology have all developed similar institutional structures to support research focusing on the interplay of these two technologies. For instance, one of the leaders of this trend, the Stanford Medical Informatics (SMI) program, was created as an interdisciplinary academic and research group within the Department of Medicine at the Stanford University School of Medicine. SMI was inaugurated in 1999 to provide a home for over 20 full-time faculty, part-time researchers, and interested medical students, all in order to bring together individuals capable of creating and validating "models of how knowledge and data are used within biomedicine."<sup>3</sup> In fact, over half of the states in the country contain universities that support some kind of bioinformatics department, and similar degree-granting institutions exist elsewhere around the world, including in Europe, Canada, and Australia.

---

<sup>1</sup> cben.rice.edu.

<sup>2</sup> smi.stanford.edu.

<sup>3</sup> corporate.stanford.edu/research/programs/smi.html

*Inter-Firm Strategic Alliances*

A third strong indicator related to converging technologies is the creation of numerous inter-firm strategic alliances between companies that have, traditionally, worked in different sectors and generated different kinds of products. In fact, it should not be surprising that as research centered on the different interfaces of technology becomes more prevalent and common within academia and government, private corporations will move to benefit from such convergence by investing in new products and creating new markets. However, in order to maximize the impacts from such convergence, corporations may decide to partner with one another so that they can share competencies, gain from each other's central capabilities, and profit by aligning their efforts in a like-minded manner.

Because the nanotechnology sector, in particular, is relatively young, it might appear somewhat surprising that there have been a number of inter-firm strategic alliances between companies that occupy a variety of different sectors of the market, and that corporate partnerships related to nanotechnology have begun to flourish over recent years. To support this claim, LuxResearch, a private technology consulting company, pointed out in its recently released *The Nanotech Report 2004* that 30% of the companies comprising the Dow Jones Industrial Average have already announced partnerships related to nanotechnology. Moreover, this report notes that of the eight nanotechnology-related mergers and acquisitions that took place in 2003, "three were in semiconductor capital equipment, and two were in chemicals," thereby denoting an initial trend toward the convergence of nanotechnology with the electronics and chemical industries (LuxResearch, 2004: xii). One such alliance included Nanosys, Inc., a manufacturer of nano-sized particles, with Eastman Kodak Company and H. B. Fuller Company, both of which are interested in the chemical and reactive properties of these particles. Moreover, this report predicts that because such alliances between different kinds of companies are continuing to increase, instances of such partnerships should rise to about five times the current level in just 3–5 years.

In addition to the formation of strategic alliances between many smaller companies and larger, more diverse companies, there are two particular instances of strategic alliance formation that offer an excellent depiction of companies that operate in different sectors of the economy but that are intent on linking with one another in order to take advantage of the potential benefits arising from converging technologies. The first alliance is at the "nano-bio" interface and originally consisted of the formation of an Industrial Consortium between Dupont, Partners Healthcare, and Raytheon in conjunction with MIT's Institute for Soldier Nanotechnologies (ISN).<sup>1</sup> The

---

<sup>1</sup> [web.mit.edu/isn/partners/industry/currentpartners.html](http://web.mit.edu/isn/partners/industry/currentpartners.html).

purpose of the Industrial Consortium is to develop health- and materials-related products for the U.S. military that are based upon nanotechnology research undertaken at MIT. Currently, this joint venture includes 12 companies that work in a range of fields, from medical implants to personal safety equipment, and continues to accept applications for new members. By working together, these firms will be able to synthesize new developments in nanotechnology with their own experience in the field of personal health care and, in turn, improve their products and strengthen their economic viability.

With respect to the “nano-info” interface, a similar alliance occurred in Japan in 2001 between Nissei Sangyo Company, Ltd., and Hitachi, Ltd., with the formation of the Hitachi High-Technologies Corporation. The aim of this joint venture was to create a new industrial entity that was capable of augmenting Hitachi’s experience in the electronics and high-technology sector with Nissei’s marketing and global sales force, all in conjunction with new developments in nanotechnology. Therefore, the main goal of establishing Hitachi High-Technologies was to create an “integrated organization ready to develop, manufacture, market and service semiconductor manufacturing equipment, biotechnology products, and other equipment and systems in nanotechnology-related fields.”<sup>1</sup> By doing so, Hitachi and Nissei used foresight to realize that nanotechnology has the potential to revolutionize the electronics industry. In turn, these corporations have taken a significant step toward merging their different core competencies in order to create and develop innovative products. As the trend towards technological convergence continues, there is the potential for a number of fruitful relationships to be formed between different kinds of companies in different sectors of the economy.

#### *Intra-Firm Technological Expansion*

In addition to the predominance of inter-firm strategic alliances, alliances that will continue to bring companies with different technological capabilities closer together, I argue that a fourth distinct indicator of convergence is the trend toward the internal development of new technological competencies within firms and companies. In short, this trend points out that firms are beginning to reach beyond their past activities and eschew traditional technological boundaries in order to gain from the merging of nanotechnology, biotechnology, information technology, and to a lesser degree, cognitive science. One recent survey of the industry found that “experts say that the ‘big two’ nanotechnologies in the future will be nanoelectronics and nanobio, which will be attracting most of the startup dollars five years from now,” a prognostication that is encouraging firms to

---

<sup>1</sup> [www.hitachi-hitec.com/oversea/about/](http://www.hitachi-hitec.com/oversea/about/).

reevaluate their own internal business practices to make certain that they have a diverse set of technological resources and qualified personnel (Red Herring, 2003). LuxResearch's *The Nanotech Report 2004* also points out that firms are diversifying their use of different technologies, with "63% of the 30 companies comprising the Dow Jones Industrial Average (Dow) . . . currently funding R&D in nanotechnology" (LuxResearch, 2004: xii). In addition, the ETC Group indicates that a variety of companies partaking in different economic sectors from around the world, including energy (Exxon, Mobil), information technology (IBM, Lucent, Motorola), chemicals (Johnson & Johnson, Dow Chemical), and electronics (Sony, Xerox, and Toshiba), have begun to invest in or undertake research in nanotechnology in order to improve their performance and become a leader in the next technology wave.

Moreover, in addition to the money being spent on private research and development in nanotechnology, there are a number of intriguing companies engaged in the first instances of research and development related to converging technologies, including Applied Digital, Xerox, Hewlett Packard, and Nestlé. Moreover, each one is employing developments in new technologies at different interfaces and is stewarding products that are at different stages of development. The first two corporations, Applied Digital and Xerox, are concerned with the "bio-info" intersection. Applied Digital recently received U.S. Food and Drug Administration approval for the implantation of a sub-dermal microchip that can transmit a patient's entire medical history to a hospital's computer system. Using Radio Frequency Identification (RFID) tag technology, Applied Digital has been able to create a product that allows biological information to be scanned and downloaded to any compatible receiver, with the hope that medical errors, and their associated costs, will be reduced. The development of such a product requires that the company be well versed in the latest information technology systems, the needs of the health care profession, and the health and biological impacts of having its product permanently implanted under the skin.

Similarly, Xerox's Palo Alto Research Center (PARC) is working on creating new information technology platforms that will help biomedical researchers manage and organize their data while simultaneously providing them with state-of-the-art computing systems that should help increase the pace of medical research.<sup>1</sup> In particular, Xerox PARC is working on creating new software tools that can more expeditiously sequence peptides, a task that is fundamental to research in the fields of proteomics and genomics. Furthermore, Xerox PARC is undertaking interdisciplinary work that will provide fast, accurate software designed for pattern recognitions, with the hope that these kinds of "bio-info" developments will be able to detect and

---

<sup>1</sup> [www.scripps-parc.com/projects.php](http://www.scripps-parc.com/projects.php).

identify rare, and potentially harmful, cells and mutations. It is evident that this kind of software will provide bench scientists with powerful new instruments capable of repeatedly scanning a large number of cells. Such advancements are possible only if a corporation is committed to expanding its core competencies into a variety of science and technology fields of study and to taking the risk of working at the leading edge of interdisciplinary research.

Along the same line, Hewlett Packard is conducting similar multifaceted work at the “info-nano” crossing point. Under the auspices of HP Advanced Study Labs, the Quantum Science Research project has been inaugurated under the direction of Stan Williams, a well-known innovator, with the purpose of understanding how nanotechnology fits within the context of HP’s information and communication technology products. By studying the electrical and physical properties of nanoscale structures, the Quantum Science Research project has been able to “grow” self-assembling nanoscale wires, products that would “allow researchers to integrate a variety of sensors into conventional circuitry” (Ulrich, 2004). Eventually, this “info-nano” technology has the potential to take on a biotechnological aspect, as it may be used to “build a nanowire sensor that can detect complementary fragments of DNA” or “to create sensors that can detect minute concentrations of biological and chemical materials” (Ulrich, 2004). Historically, such a “bio-info-nano” convergence would have been unexpected from a corporation whose main product was personal printers. However, today, HP Advanced Study Labs is on the leading edge of combining breakthroughs in various fields, all with an eye toward redesigning the corporation’s product line and providing the company with expertise in previously unexpected kinds of technology.

Finally, Nestlé is applying insights from nanotechnology to help improve the quality of its food products. The application of such “high” technology to a rather “low-technology” industry, such as food and food manufacturing, may become one of the dominant trends over the near and long-term future. Along these lines, Nestlé has established a Research Center at its headquarters in order to expand its knowledge of how materials science and the physics of colloid particles impact the structure and quality of consumable food. Specifically, their Food Science department is, in part, devoted to determining the potential links between food and nanotechnology, and there is the expectation that “researchers may soon be able to use nanotechnology to make artificial noses and mouths for tasting foods, and to make packaging that prevents microbial growth” (Baard, 2004). Eventually, nanoparticles may be placed directly into certain foods, such as ice cream, in order to allow the manufacturer to “control the texture, flavor release and rate at which nutrients are absorbed by the body (Baard, 2004). These developments at the boundary of nutrition and nanotechnology may lead

other companies toward expanding their resources and encourage them to engage in certain kinds of research, such as forays into the realm of nanotechnology, that were once thought to be unrelated or unnecessary.

### *Patent Citations*

The last indicator that demonstrates the convergence of different technologies is more quantitative in nature than the previous four. Counting the number of patents – and their subsequent citations – filed in relation to intersecting branches of technology can provide evidence of the trend toward convergence. However, in some cases such numbers can be misleading. The lag time between the initiation of a research project, patent application, and a subsequent citation can range from a few months to many years; in fact, patent filing is a long and arduous process that may not be finalized until a significant amount of time has passed since the initial discovery or innovation. Moreover, the cross-fertilization that I have identified as occurring between scientific disciplines has only begun to truly accelerate over the past half decade, as the idea of converging technologies has become more well known and accepted. Finally, it is important to note that undertaking a comprehensive analysis of citations in patents is well beyond the scope of this chapter. However, such a full-blown project would be useful in the future, especially in order to provide more substantial evidence that such convergence has infiltrated a variety of scientific disciplines.

With respect to patent citations, the most useful data have been made available through three different studies that have a primary focus on the U.S. Patent and Trademark Office (PTO) and deal with either the interface between nanotechnology and biotechnology on one hand, or the interface between different kinds of information and communication technologies on the other. For instance, in an article devoted to the subject of how converging technologies will create new educational and training opportunities in the future, Mihail Roco has pointed out that patent citation data indicate that there is evidence that a significant and ongoing convergence at the nanoscale has begun to occur. He argues that “patent trends and new venture funding for 2002-2003 show an increase in the proportion of nanobiotechnology users to about 30%” (Roco, 2003: 2). Similarly, Roco reports that “of 6,400 nanotechnology patents identified in 2002 at the U.S. Patent and Trademark Office, the leading numbers [of related subjects] are for molecular biology and microbiology (roughly 1,200 patents) and for drug, bio-affecting and body treating compositions (about 800 patents), together representing about 31% of the total patents in the respective year” (Roco, 2003: 2). A majority of these statistics arise from a large, landmark study that was published in the *Journal of Nanoparticle Research*, a study undertaken to analyze the specific patent trends that have surfaced in the nanotechnology sector. For example,

the authors of this article found that “‘chemistry: molecular biology and microbiology’ was revealed to be the technology field with the most influential patents” related to nanotechnology (Huang *et al.*, 2003: 347). In short, an examination of patent filings demonstrates that technologies are beginning to converge on the nanoscale and that they are having a widespread impact in a number of disparate fields, including chemistry, molecular biology, and microbiology.

Another study, published in *Nanotechnology Law and Business* (Koppikar *et al.*, 2004), has pointed out that in 2003, patent filings in the United States alone showed a rise in citations related to nanotechnology, with such terms as atomic force microscope (AFM; over 600) and dendrimer (over 100), up from their 1994 baselines of 100 for the former and only 10 for the latter. Although this increase in patents citing such nanotechnology-related developments does not, in and of itself, illustrate the exact convergence of technologies at the nanoscale, it does demonstrate that nanotechnology is rapidly coming to influence and affect discoveries in other areas of science and technology. Moreover, it is the case that the eventual applications of nanotechnology-related innovations, such as AFMs and dendrimers, possess the very real potential of becoming applied to biotechnology and information technology. In particular, the main expected application of dendrimers is as “nanoscale scaffolds,” which would be capable of delivering pharmaceuticals and drug therapies to specific sites in the body. The assumption here is that any patent citing such a reference is more likely than not to have an impact in biotechnology and, therefore, offers the potential to bridge the gap between pure nanotechnology research and applied “nano-bio” products in the future.

Unfortunately, it is currently difficult to glean much additional information from patent citations, regardless of whether it is in regards to nanotechnology or information technology. Specifically, with respect to nanotechnology, it was clear that up until early 2004, “the Patent Office [had] no immediate plans to create a nanotechnology examining group,” thereby stifling a researcher’s ability to learn about convergence at the nanoscale because the exact nomenclature and categorization remained in flux (Koppikar *et al.*, 2004: 2–3). In other words, this lack of an agreed-upon classification system implied that nanotechnology-related patents would remain unorganized and spread out across a majority of the PTO, making it difficult for researchers to undertake a robust bibliometric study of the convergence between nanotechnology and other disciplines. Fortunately, in October 2004, the PTO decided that it was worthwhile to develop a more robust system of handling nanotechnology patents, thereby creating “a new registration category just for nanotechnology inventions” (Feder, 2004). This special category will allow for better tracking and measurement of innovations in nanotechnology, and it will go a long way in providing information regarding this discipline’s convergence with other technologies.



Hopefully, the holes that are present in the different studies outlined above will spur other researchers to address some of these challenges and encourage them to undertake a fuller, multi-disciplinary patent citation analysis that attempts to understand the true scope and reach of converging technologies.

### **Converging Technology Policy Plan of Action: Recommendations and Suggestions**

Having outlined some of the useful indicators that illustrate the initiation of convergence between a variety of scientific and technological disciplines, I contend that there are a number of additional steps that need to be taken that will allow society to harness this trend completely and benefit from it fully. As I mentioned earlier, the NSF/DOC and EU reports have already made the point of calling for a specific, targeted, government-sponsored, research priority program that has a distinct and concentrated focus on converging technologies. However, I imagine that such efforts will need to be complemented and augmented by other undertakings in order to ensure that converging technologies are capable of having the widest possible positive impact on society. Along these lines, the following policy “plan of action” attempts to identify and outline five key topics that must be taken into account as the converging technology agenda moves forward. Through a discussion of these issues – which include education reform and job training, the development of improved bibliometrics, creating a body of case study analyses with a focus on neuroscience and cognitive science, concern for international collaboration and development, and public participation and engagement – I will pinpoint some of the gaps in need of being filled and offer potential recommendations that will help ensure that the idea of converging technologies will become more embedded and integrated into the public consciousness. Again, these suggestions should be viewed as only a start to the policymaking process. As time progresses, new and creative options for managing converging technologies will emerge, thereby requiring additional deliberations and the presentation of new, adaptive policies over the coming years.

First, it is clear that the convergence of technologies will require a radical reform in education and a new investment in job training and retraining for the worker of the 21st century. The merging and intersection of disciplines will require that these developments are reflected and mirrored in the elementary, undergraduate, and graduate education system. As I outlined in an earlier section, some moves along these lines, especially at the graduate level, have already begun to occur. However, the innovative programs that I highlighted are, unfortunately, not the norm; instead, a majority of science and technology education continues to follow along traditional disciplinary boundaries and lacks any effective means to demonstrate the interactions that

exist between different subjects. In his article on the subject, Roco emphasizes this point and notes that the only way to truly benefit from converging technologies is if the “interdisciplinary connections reflecting unity in nature” are elucidated and revealed within the education system itself (Roco, 2003: 2). Admittedly, undertaking such reform is difficult. Still, one way to solve this problem, as Roco suggests, is to reverse “the current pyramid of learning that begins with specific techniques and formalisms in the first year of undergraduate studies and ends with a coherent understanding of physical and biological features” (Roco, 2003: 3). State and local education boards could provide incentives by way of awarding salary increases to teachers who seek out advanced and additional training with regards to converging technologies. Finally, government agencies could make a point of funding educational initiatives that demonstrate a willingness or desire to work at the interface of different disciplines and at the nexus of different technologies.

Similarly, much like the needed reform in the education system, workers will have to be trained and retrained with skills and updated knowledge that integrates a multi-disciplinary approach to science and technology. Roco notes that developments in nanotechnology alone will require about 2 million new workers by 2015, a figure that, I contend, will continue to rise as the convergence between this discipline and others continues to move forward. Governments must become aware of this impending need for new kinds of human talent and expertise, and in turn, they must consciously design worker training and retraining programs that are capable of meeting this need. Along these lines, well-regarded advisory bodies – such as the National Academies of Science in the United States and the Royal Society in Britain – should be commissioned to put together committees with the intention of the studying how to best update the science and technology workforce for the 21st century. The ability of such review boards to offer and advance concrete recommendations for policymakers will be a necessary component of bringing this issue of worker training to the fore. In addition, these high-level reviews – which will address how to institute the changes that will be needed to bring the science and technology workforce in line with the new demands of convergence – will also be able to provide government officials with quantitative data and statistics that will make it easier for these decision-makers to grasp the importance of this emerging trend while, simultaneously, helping these elected representatives “sell” such changes to their constituencies.

This conclusion with respect to education and worker training leads directly into the second recommendation, which calls for researchers in universities, government agencies, and non-governmental organizations to concern themselves with developing improved bibliometric measurements that can further highlight the extent and nature of converging technologies.

As I mentioned earlier, although some studies with a focus on quantitative bibliometrics, such as patent citations in the realm of nanotechnology and information technology, do exist, there are few broad and well-accepted analyses that take a more comprehensive view regarding the various interfaces that have arisen between different technologies. In short, there is little work being done that attempts to quantify how these metrics can be measured across different fields and disciplines. A number of organizations, including the Washington Research Evaluation Network, possess experience in the generation of such bibliometrics, and it would be useful if these kinds of research evaluation organizations could apply their technological and scholarly capabilities to such a project. Undoubtedly, a number of stakeholders, from academics to policymakers to interested citizens, would be interested in gaining access to better data regarding technology convergence. In particular, grant-giving agencies, such as the NSF, would welcome such information, primarily because it could help inform their funding decisions and provide them with another dimension with which to analyze the importance and viability of competing applications. Finally, improving these bibliometrics would also help ingrain and establish the notion of converging technologies within the mindset of policymakers by providing them with tangible measurements that would strongly indicate a movement in the direction of the hybridization and merger of different technologies.

Third, it would be useful for interested parties to develop in-depth case studies with an emphasis on highlighting the individuals, corporations, and laboratories that are benefiting from and employing converging technologies. These kinds of case studies – which could make a point of detailing such trends as inter-firm strategic alliances or intra-firm diversification of technological capability – would go a long way in filling the current gaps in the literature and would come to serve as the foundation for all future analyses of technological convergence. In particular, there is a great need for such case studies to focus on the interface between neuro/cognitive/brain science and other disciplines, primarily because, as I noted earlier, these kinds of interfaces have garnered less attention than their counterparts. One example of this type of case study was recently undertaken by the Foresight and Governance Project at the Woodrow Wilson International Center for Scholars. By focusing on the intersection between neuroscience and information technology, this exposition offered an analysis of so-called Neural Virtual Reality (NVR) and was able to not only underscore the technical and practical means that underlie this form of technological convergence but also highlight a number of potential policy implications as well, including issues related to education, worker training, and health care. In short, the development of a robust and well-executed body of case studies – that would range across the wide spectrum of technological convergence –

would help flesh out the quantitative information provided by improved bibliometrics while, simultaneously, have the ability to emphasize areas of convergence that have yet to become popularized or well-known.

A fourth, and quite necessary, aspect of any converging technology policy plan of action is to understand the significant international aspects of science and technology and to be cognizant of the fact that converging technologies have the potential to help nations collaborate, to help countries develop, and to help advance state-of-the-art research worldwide. For instance, the very fact that the EU compiled a high-level commission to analyze the role of converging technologies – an idea that was initially presented by the NSF/DOC-supported workshop in the United States – demonstrates the fluidity of science and technology ideas across international borders and underscores how this notion is beginning to shape the way people think around the world. Because both the EU and NSF/DOC reports call for establishing a research priority area on converging technologies within their respective governments, it appears that there is considerable room for collaboration, in which both the European and American governments would work together to ensure that mutually compatible programs are launched in conjunction with one another. Moreover, there is the potential for these governments to help expand research on converging technologies to other developed countries, such as Japan or Australia, with the hope that by engaging such nations early on, all of the issues surrounding and related to converging technologies will be constructed, debated, and resolved on an international scale.

Along these lines, I argue that there must be a concerted effort by the developed world to apply the derived benefits of converging technologies to the developing world. It is clear that potentially extraordinary gains could emerge once different technologies begin to work together – gains that are most needed and would be most useful in areas of the world that are suffering from extreme poverty and degradation. In a recent talk at the Foresight Institute's Conference on Advanced Nanotechnology, sociologist Bryan Bruns noted that when developed in conjunction with other technologies, "advanced nanotechnologies could help poor people improve their lives, if developed in ways that are appropriate and accessible" (Bruns, 2004). One way to ensure that converging technologies are deliberately directed toward helping the poor is for countries in the developed world to sponsor a forward-thinking program that analyzes the development-related issues arising from converging technologies, perhaps under the auspices of a multi-lateral, internationally minded organization, such as the United Nations, the World Bank, or the International Monetary Fund. In particular, the United States could use its recent decision to rejoin the United Nations Educational, Scientific, and Cultural Organization (UNESCO) as a catalyst for such a development-friendly initiative. By situating such a program within

UNESCO, the United States could leverage the power and influence of this far-reaching body and make certain that the human development issues raised by converging technologies are placed at the forefront of the international science and technology policy agenda.

Finally, it is recommended that a variety of institutions, including universities, governments, think tanks, and corporations, become committed to holding public forums and provide platforms for discussing the complex issues inherent in the onset of converging technologies. To be sure, any discussion that is held regarding the pros and cons of converging technologies will require an open and honest debate that will touch upon a variety of issues, including morals, values, acceptable scientific practice, and desired goals and end-states. However, as the ETC Group report mentions, without such public participation, there is the real chance that the benefits of converging technologies could become overshadowed by their drawbacks, as the public becomes less engaged and involved in setting priorities and guiding policy. For instance, the potentially damaging health and environmental risks associated with certain technologies – in particular, nanotechnology – must be dealt with in an open and transparent manner to avoid crises similar to those that occurred with asbestos and thalidomide. Along the same line, there are a number of ethical, legal, and social concerns that will continue to arise with respect to certain kinds of research in cognitive science and biotechnology. In short, these worries will require that a deliberate attempt by all stakeholders is taken to encourage public and citizen participation, thereby ensuring that widespread input will help shape the future impact of converging technologies.

To make certain that a variety of viewpoints are heard, the media and press must use their role as gadflies and safeguards of the public interest to help guarantee that the marginalized voices of overlooked and ignored stakeholders have the chance to come to the fore, share their views, and elucidate their concerns. The importance of such contributions has been underscored by James Wilsdon and Rebecca Willis in 2004, who argue in favor of encouraging broad public engagement “upstream”; namely, at the beginning of any enterprise that is related to the research and development of converging technologies. By advancing this notion of “see-through science” – which calls for the public to play an integral role in the policy-making and agenda-setting process – the authors make clear that embodied in the hype surrounding the benefits of technological convergence lies “a set of assumptions about future human and social needs that are contestable and should be debated” (Wilsdon and Willis, 2004: 35). In short, this kind of “see-through science” needs to become an essential aspect of all decisions or policies taken in relation to converging technologies, and its adoption will require actions that lead to the collection of a wide number of views, the

assessment of a wide range of values, and input from a wide variety of sources.

### **Conclusion: A Multidimensional Framework for Analyzing Converging Technologies**

To be sure, it is clear that even though the convergence of different technologies has yet to reach its peak, indicators do exist denoting that movement along these lines is already beginning to occur. Whether it is the funding of interdisciplinary projects by government agencies, the establishment of new degree-granting programs by universities, or the development of strategic alliances between corporations, I conclude that there are a number of mutually complementary ways to analyze the onset and impact of converging technologies. By providing a multidimensional framework that categorizes the value of these various metrics, I have demonstrated that future examinations of the converging technology phenomenon can and should move beyond the presentation of mere abstract pronouncements regarding the potentials of convergence toward a more substantial investigation and examination of how convergence should be identified, evaluated, and assessed.

In particular, I have laid out areas that will require more work and attention in future investigations, including the development of improved and more robust bibliometrics, greater public participation in defining the underlying aims and goals of convergence, and an explicit focus on international collaboration and development. The identification of these gaps is meant to spur additional research that will add to the growing body of literature in the field. In short, a deeper understanding of how technologies converge, intersect, and relate to one another in practice will begin to arise as the ideas from the foundational NSF/DOC and EU reports expand, take hold, and influence the greater science and technology policy community. Moreover, as the wider adoption of this mindset increases, it should not be surprising that additional, unexpected facets related to technological convergence will come to light. In addition, it should not be surprising that a host of new questions – such as how this trend affects the pace of technological innovation and how it impacts the economics of research and development – will come to the fore. As new indicators – that are capable of expressing the reach, scope, and breadth of this phenomenon appear and come to the surface, it will be of paramount importance to persistently and systematically reevaluate the notion of converging technologies in an attempt to understand how this dominant theme in science and technology policy will evolve and mature over time.

## References

- Baard, M. 2004. Little things could mean a lot. *Wired Magazine* (March 10), [www.wired.com/news/technology/0,1282,62602,00.html](http://www.wired.com/news/technology/0,1282,62602,00.html).
- Bruns, B. 2004. Applying nanotechnology to the challenges of global poverty. Foresight Institute, [www.foresight.org/Conferences/AdvNano2004/Abstracts/Bruns/](http://www.foresight.org/Conferences/AdvNano2004/Abstracts/Bruns/).
- ETC Group. 2003. *The Big Down: From Genomes to Atoms*. Winnipeg, Canada: ETC Group.
- ETC Group. 2004. *Down on the Farm: The Impact of Nano-Scale Technologies on Food and Agriculture*. Winnipeg, Canada: ETC Group.
- Feder, B. J. Tiny ideas coming of age. *The New York Times*, (October 24, section 4): 12.
- Genetos, A. 2004. *Neural Virtual Reality: A Dream or a Nightmare?* Washington, D.C.: Foresight and Governance Project, Woodrow Wilson International Center for Scholars.
- Huang, Z., H. Chen, and A. Yip. 2003. Longitudinal patent analysis for nanoscale science and engineering: Country, institution and technology field. *Journal of Nanoparticle Research* 5(3–4): 333–363.
- Koppikar, V., S. B. Maebius, and J. S. Rutt. 2004. Current trends in nanotech patents: A view from inside the patent office. *Nanotechnology Law and Business*, 1(1).
- LuxResearch. 2004. *The Nanotech Report 2004*. New York: LuxResearch.
- Miller, S. E., and M. C. Roco. 2003. A new renaissance: Tech, science, engineering and medicine are becoming one. *New York Law Journal*, October 7.
- National Science and Technology Council. 2003. *National Nanotechnology Initiative Supplement to the President's FY 2004 Budget*. Washington, D.C.: Office of Science and Technology Policy.
- Nordmann, A. (ed.) 2004. *Converging Technologies – Shaping the Future of European Societies*. European Commission, [www.ntnu.no/2020/final\\_report\\_en.pdf](http://www.ntnu.no/2020/final_report_en.pdf).
- Red Herring. 2003. *ICC Report: Nanotechnology: Worth Its Wait?* Mountain View, Calif.: Red Herring.
- Risk Assessment Unit. 2004. *Nanotechnologies: A Preliminary Risk Analysis on the Basis of a Workshop Organized in Brussels on 1-2 March 2004 by the Health and Consumer Protection Directorate General of the European Commission*. Brussels, Belgium: European Communities.
- Roco, M. C. 2003. Converging science and technology at the nanoscale: Opportunities for education and training. *Nature Biotechnology* 21(10): 1247–1249.
- Roco, M. C. and Bainbridge, W.S. (ed.) 2003. *Converging Technologies for Improving Human Performance*. Dordrecht, Netherlands: Kluwer.
- Stein, R. 2004. Implantable medical ID approved by FDA. *The Washington Post*, October 14: A01.
- Ulrich, T. 2004. Quantum leap: Reinventing the integrated circuit with molecular-scale electronics. Hewlett-Packard, [www.hpl.hp.com/news/2004/july\\_sept/quantum.html](http://www.hpl.hp.com/news/2004/july_sept/quantum.html).

- U.S. Department of Agriculture. 2003. *21st Century Agriculture: A Critical Role for Science and Technology*. Washington, D.C.: Department of Agriculture.
- U.S. Department of Health and Human Services. 2004. *The Decade of Health Information Technology: Delivering Consumer-Centric and Information-Rich Health Care*. Washington, D.C.: Department of Health and Human Services.
- Wilsdon, J. and Willis, R. 2004. *See-Through Science: Why Public Engagement Needs to Move Upstream*. London: Demos.



## 6. COLLABORATION ON CONVERGING TECHNOLOGIES: EDUCATION AND PRACTICE

*Michael E. Gorman and James Groves, University of Virginia*

*Abstract:* Interdisciplinary collaboration of the sort required by convergent technologies, which will have to include ethics and social sciences as well as multiple fields of physical science and engineering, raises the problem of incommensurability. Different disciplinary cultures may be unable to understand one another, making it impossible to agree on goals. This chapter develops a framework for overcoming apparent incommensurabilities to pursue goals that promise social as well as technological progress. Even cultures with very different perspectives can trade, and from such trades, deeper understandings can grow – if participants in the trading zone exercise moral imagination. In order to shape converging technologies, students need to be taught not only disciplinary depth but also the ability to become interactional experts who can facilitate trades across disciplinary cultures. The chapter concludes with a list of techniques for encouraging and monitoring the development of this kind of interactional expertise, including a simulation that puts students in the role of policy-makers.

### Introduction

Converging technologies will require collaborations among disciplines on an unprecedented scale. Because converging technologies hold the potential to dramatically change human capabilities, such collaborations will have to not only stretch across multiple technical fields but also include ethics and social sciences. Most scientists, engineers, ethicists, and social scientists are not trained to do this sort of collaboration, because their education focuses on disciplinary depth.

Thomas Kuhn argued that scientific breakthroughs produced new paradigms, or perspectives linked to sets of practices. Those scientists still in the old paradigm literally could not understand the central features of the new one. So, for example, there were very few scientists who understood relativity theory after Einstein published it, and those who did found it hard to communicate with those who did not.

Kuhn referred to this as the problem of incommensurability. He illustrated it with a classic experiment in Gestalt psychology, in which participants were asked to identify cards at very short exposures. Most were trivial, but the experimenters snuck anomalies into the deck – a black four of hearts, or a red six of spades. Initially, participants classified the heart as red and the spade as black, but as exposures grew longer, they became increasingly

uncomfortable, and then at one point switched to a new view. Once they realized anomalous cards were possible, these participants were able to identify them quickly. They were, in a sense, operating in a new paradigm; they saw possibilities that someone from the old paradigm would not.

Now, these experimental participants could have communicated the shift easily to other potential participants – “this crazy experimenter is going to stick in some black hearts and red spades, so look out.” Kuhn’s point is that the scientist, trained in the traditional paradigm, does not have the tools or the training to detect a red spade. This view may be an exaggeration; there are cases, such as plate tectonics, in which theoretical groups do navigate the change from one view to another (Giere, 1992). However, Kuhn has captured an essential problem that makes interdisciplinary collaboration difficult. Disciplines are cultures, with embedded practices and ways of thinking that have been successful at tackling certain kinds of problems. When a new problem or opportunity arises that does not fall into one of the traditional disciplinary bins – such as converging technologies – then practitioners from different fields may find they have fundamentally different perspectives on it, including whether there really is an opportunity. An example is the deep divide between chemists and nuclear physicists regarding the possibility of cold fusion: Many of the former thought it might be possible, whereas a member of the latter community, after seeing one of the cold fusion experimenters standing next to his fuel cell, noted that the radiation byproducts should have caused body parts to fall off (Close, 1991: 114).

In this chapter, we will use the literature on science and technology studies to develop a framework that shows how deep, creative collaborations can be formed around converging technologies. We will conclude with some observations about education and NBIC.

### **Superordinate Goals**

Social-psychologist Muzifer Sherif once reminisced:

As an adolescent with a great deal of curiosity about things, I saw the effects of war: families who lost their men and dislocations of human beings. I saw hunger. I saw people killed on my side of national affiliation; I saw people killed on the other side. . . . It influenced me deeply to see each group with a selfless degree of comradeship within its bounds and a correspondingly intense degree of animosity, destructiveness, and vindictiveness toward the detested outgroup – their behavior characterized by compassion and prejudice, heights of self-sacrifice, and bestial destructiveness. At that early age, I decided to devote my life to studying and understanding the causes of these things. (Sherif, 1967: 9)

To explore the origins of intergroup hostility and how to overcome it, Sherif ran a series of experiments at a summer camp near Robber's Cave, Oklahoma. He took boys from a relatively homogeneous middle-class, Protestant background and divided them into two similar groups. His goal was to see whether he could induce intergroup hostility in a sample that had no prior history of hatred or division.

He and the camp counselors encouraged competition via contests like tug of war, conducted over several days. The winning group would receive a desirable prize – a set of knives. The two groups gave themselves separate names – in one study, it was “Rattlers” and “Eagles” – and separate flags. Food fights, raids, and counter-raids occurred, and there would have been fist fights but for the efforts of the counselors. Intergroup hostility increased in-group hostility and also led to changes in leadership as more peacefully inclined boys slipped down the in-group hierarchy.

How could this hostility be overcome? Simply providing opportunities for peaceful contact between group members did not reduce hostility. The Sherifs (Muzafer's closest collaborator was his wife, Carolyn) tried a common enemy strategy: uniting the groups long enough to play boys from town in softball. This worked at least temporarily, but Sherif felt this only took the problem of intergroup hostility to another level.

The Sherifs then tried uniting the boys around “superordinate goals,” problems that would be urgent for both groups, threatening their survival, and would require them to combine resources and energy. First, the staff simulated a problem with the camp's water supply and sent the thirsty boys out to solve it. The two groups began to work together and discovered that vandals (actually camp staff) had plugged the faucet. Afterward, however, group members returned to their previous hostility towards each other.

Then the staff simulated a problem with a truck that was going to get lunches for the boys, after a day of swimming and activities. The hungry boys watched the truck stall, and then saw their old tug-of-war rope lying conveniently nearby. Each group pulled on a separate part of the rope and got the truck going. When it came back, the boys jointly spread out the food, and when the truck stalled again, the groups mingled to pull the ropes. The groups decided to go back to the camp together.

The intergroup hostility created and resolved by the Sherifs was on a much smaller scale than that encountered in much of the world, where between-group hostilities can be fueled by differences in language, religion, and appearance and by hundreds of years of repeated hostile acts. But the resolution is instructive: If groups in the world could be convinced that their survival was at stake, and that only by combining resources could they survive, then it might be possible to overcome intergroup hostilities – especially if this kind of challenge were faced more than once.

However, the problem of incommensurability means that it is very hard for groups to see that they are facing a common problem. The boys in the summer camp saw this clearly with the water tank and the lunches. But suppose one group had privileged access to both resources, and an ideology that told them the other group was inferior? There would have been no problem, from their standpoint.

Consider converging technologies. If NBIC convergences are used to ensure that some cultures benefit while others are left behind, then they will not constitute a superordinate goal. If, however, they are aimed at problems like increasing global affluence, increasing educational opportunities for women, and managing the ecosystem in a way that benefits all, then NBIC convergence could be a route to achieving superordinate goals. Technology is one of the keys to linking these goals. If the developing world follows the pattern of the first industrial revolution, then affluence will come at the expense of the environment, but new technologies and adaptive management techniques can make it possible to have a cleaner industrial revolution (Allenby, 2000/2001; Rejeski, 2004). If affluence comes with educational opportunities for women, then the global population will actually decrease, further reducing the strain on the environment (Sen, 1999).

### **Trading Zones**

Peter Galison, a distinguished historian of science, used the metaphor of a trading zone to explain how scientists and engineers from different disciplinary cultures managed to collaborate across apparently incommensurable paradigms. He studied the development of radar and particle accelerators and found that different expertise communities had to develop a creole, or reduced common language, to get around the problem of incommensurability. “They can come to a consensus about the procedure of exchange, about the mechanisms to determine when goods are ‘equal’ to one another. They can even both understand that the continuation of the exchange is a prerequisite to the survival of the larger community of which they are part” (Galison, 1997: 803).

At MIT’s Radiation Laboratory (Rad Lab), which focused on developing radar during World War II, physicists began with the fundamental research, and engineers began with how to turn this research into manufacturable devices. The engineering constraints often forced the physicists to conduct further research. These two communities had to exchange knowledge – and also had to incorporate the knowledge of technicians, who understood the conditions under which the devices would be used and repaired. All of these communities shared a superordinate goal involving a common enemy that threatened the survival of their communities.

Trading zones can be motivated by the common goal of exploration. The term “trade” was used by JPL engineers and scientists to reach agreement on where to land a Mars Rover and what to carry on it (Lambert and Shaw, 2002). Scientists see one kind of location as ideal for exploring water, and engineers see another as optimal from the standpoint of fuel, cost, and time. The two groups have to trade not only with regard to landing location but also on issues like what power source to use on the Rover, how much impact is sustainable on landing, and a host of other issues.

Very little research has looked at the kinds of creole that emerge in any detail. With a small amount of funding from the National Science Foundation (NSF), we created a trading zone motivated by using nanotechnology to make the world a better place. We shared an engineering graduate student with a materials scientist, and our thinking processes were documented by a cognitive scientist (Gorman *et al.*, 2004). In order to trade, members of this small zone had to develop a creole. Instead of developing new terms, we had to find shared meanings for terms used in our respective domains. Gorman had to learn what “directed self-assembly” meant, and why isoelectric points and lattice structures were important. Groves and Catalano had to learn what “trading zones” and “moral imagination” meant. Shared understanding of these terms evolved through frequent explanations, collaborative poster sessions, and publications.

Gorman’s understanding of a term like “directed self-assembly” was never as deep – as replete with examples – as that of Groves, and vice versa with respect to the concept of a trading zone.

#### *Metaphors as Part of a Creole*

A surprising finding was that the team also had to develop a metaphoric language to talk about its goals (see Figure 1). All three participants in this zone liked hiking, which is why this seemed a natural set of metaphors. Groves took the lead in creating the language. Distant mountains are major global problems and opportunities, like human health, climate change, the prevalence of warfare, and so on. Closer foothills represented specific aspects of these problems, like the elimination of heart disease, or cancer, or providing more data on toxins introduced into the environment either as a form of biological warfare or as pollution. The team wanted to build a bridge that could be used by us or others to reach a range of local mountains or foothills. This bridge would be part of a trail but could also give access to other trails.

The team considered the expertise and resources available and decided to focus on gaining understanding and control of cellular mechanisms, in part because a colleague in biomedical engineering was working in this area. This colleague was specifically interested in the way endothelial cells are

transformed by mechanical forces related to flow (Helmke and Davies, 2002). The bridge, in this case, corresponded to directing the deposition of one metal oxide on another in a way that would create positive or negative surface charge (determined by the oxide's inherent isoelectric point). When a biomolecule of opposite charge came into contact with the charged metal oxide surface, that biomolecule would adhere to the surface.

This pilot study shows that it is possible to form an interdisciplinary trading zone in which a physical scientist and a social scientist jointly explore a cutting-edge topic in nanotechnology, sharing a graduate student and gradually expanding their trading zone to include others. The final choice of topic incorporated nanotechnology, biotechnology, and cognitive reflection – three of the four NBIC technologies.

**Figure 1. Metaphors Relating Societal Dimensions to Project Goals**

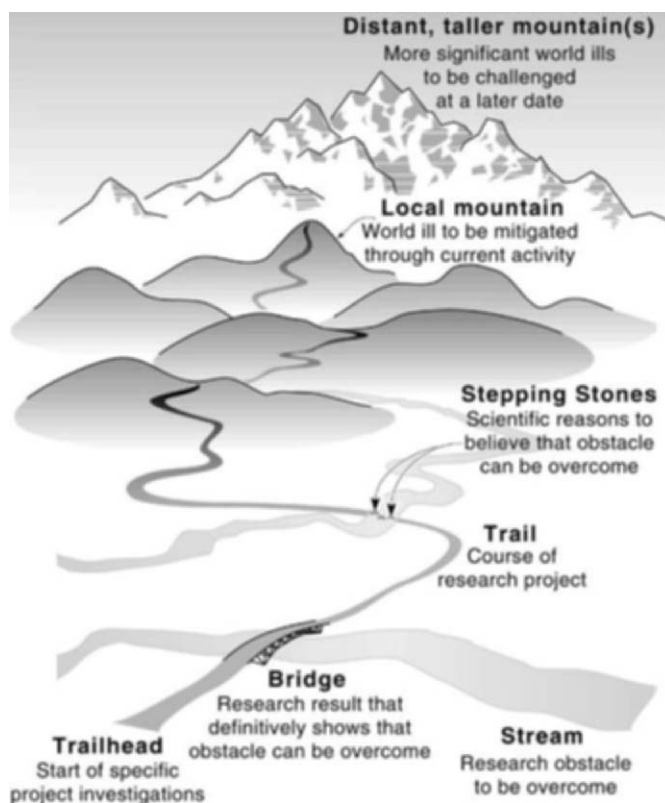

To determine whether and how this small-scale example could generalize to the varieties of trading zones that will have to emerge around converging technologies, we need to consider types of trading zones.

### *Stages in Trading Zones*

There is obviously a large set of possible trading zones, and not all will be suited to collaboration. At the outset, it is useful to think of three broad stages on a continuum. A trading zone can shift from one stage to another as it evolves. These zones are classified in terms of whether there is a superordinate goal, and how equally the trading partners are involved in setting it.

1. *A top-down trading zone, in which the superordinate goal is dictated by the dominant group or individual.* During the development of radar, the military often tried to get the MIT Rad Lab to simply develop devices according to military requirements, without understanding the mission. I. I. Rabi responded by telling Navy officers to “bring back your man who understands radar, you bring your man who understands the Navy, who understands aircraft, you bring your man who understands tactics, then we’ll talk about your needs” (Conant, 2002: 256) What Rabi was pushing for was mutual understanding and agreement on the superordinate goal, and a more active and equal trading zone.

2. *A relatively equal trading zone, which may include a boundary object or system that participants are trying to work together to create, and that sits on the boundaries of their various expertises.* In the case of radar, for example, different participants in the zone had partly unique perceptions of the emerging technology and its potential.

Donald Norman has talked about the way in which designers’ and users’ mental models can be far apart, creating problems when it comes to common devices like computers and VCRs (Norman, 1993). Similarly, radar designed by engineers might not have had the functionality needed by the military. Rabi was pushing for a shared representation of the superordinate goal, so that the designer and user mental models would be aligned. Initially, that meant that the military and civilian experts would have to trade as equals; the military could not be allowed to dominate the zone, because they could not form an adequate representation of the new technology without engaging in a dialogue with the scientists and engineers building it.

3. *A shared mental model zone, in which participants share a dynamic, evolving representation of the superordinate goal and the boundary system.* This stage in a trading zone is most characteristic of the cutting-edge design teams that created systems like the Arpanet (Hughes, 1998). One senses this kind of excitement and sharing among the core Rad Lab team, who from the start “did the best they could, hopping back and forth across organizational lines as needed and throwing out ideas to members of one group or another” (Conant, 2002: 214). Note that there is still a division of labor in a shared mental model zone, but that the organization is not rigid, or hierarchical;

roles evolve with the project, and participants “hop” across task boundaries, “flowing to the work” (Fisher and Fisher, 1998).

Another example from the same time period is the team of physicists at Los Alamos that was at the center of atomic bomb design and testing. From the start, the military wanted the project compartmentalized, with individual scientists knowing little or nothing about what was going on in other parts of the division of labor. The scientists resisted, on the grounds that knowledge sharing across the emerging organization was essential. A colloquium series served as a kind of marketplace where ideas from any quarter could be aired and exchanged, but the colloquium came to serve an even more important role. As one participant noted, “The colloquium was less a means of providing information than an institution which contributed to the viability of the Laboratory and to maintaining the sense of common effort and responsibility” (Thorpe and Shapin, 2000: 572). In other words, the colloquium kept participants aligned around their superordinate goal: producing an atomic weapon.

A Stage 3 trading zone can be a peak experience for its participants: “when the Manhattan Project at Los Alamos was wound down, many who then returned with relief to their normal university employments recalled that they had never had so much fun and that science had never been freer” (Thorpe and Shapin, 2000: 546). The usual hierarchical distinctions among scientists at different levels of eminence disappeared. “‘Here at Los Alamos’, one physicist said, ‘I found a spirit of Athens, of Plato, of an ideal republic’” (Thorpe and Shapin, 2000: 547).

#### *Types of Shared Expertise*

Two sociologists of science (Collins and Evans, 2002) have described three levels of shared expertise that line up nicely with the three stages in trading zones (Gorman, 2002a).

- *None*: This absence of sharing occurs in Stage 1 networks, in which the top gives orders and black-boxes those below into compartmentalized roles. The military wanted to create this kind of network for the development of radar and the atomic bomb. In these situations, experts throw parts of the solution over a wall to one another without really sharing knowledge. Only the top of the organization has the complete picture – and the top is focused on results, not on understanding and facilitating the process by which the results are achieved.
- *Interactional*: This kind of shared expertise is particularly important in Stage 2 networks. The interactional expert corresponds to an agent who facilitates trades by understanding the languages and norms of



the different cultures involved in the zone. The interactional expert can communicate across disciplines. Early in the development of magnetic resonance imaging, surgeons interpreted as a lesion what an engineer would have recognized as an artifact of the way the device was being used. This breakdown in the creole between these communities was recognized and solved by an interactional expert who had a background in both physics and medicine (Baird and Cohen, 1999).

- *Contributing*: This kind of shared expertise involves experts who learn enough about other disciplines to make original contributions. In the case of radar, a central facilitator was Alfred Loomis, a wealthy banker-turned-scientist who saw the potential for this technology, created the team that expanded into the Rad Lab, supplied the initial funding himself, and served as an advocate for this research in the halls of power in Washington, D.C. In addition to serving as an advocate, fundraiser, and network builder, Loomis made original contributions to the science and engineering involved in radar (Conant, 2002).

At Los Alamos, the director, J. Robert Oppenheimer, served as a cross-disciplinary contributing expert; he “integrated the laboratory by his physical circulation through it, visiting meetings in theoretical physics, experimental physics and metallurgy. . . . Some commentary, indeed, ascribes Oppenheimer’s skill at integration to the circumstance that he just knew an enormous amount of the relevant physics and, more generally, that he had a grasp of a greater range of sciences than anyone else at Los Alamos” (Thorpe and Shapin, 2000: 573).

Both Loomis and Oppenheimer nurtured Stage 3 environments, in which they also brought out the best in others. They served both the facilitative role of the interactional expert and the creative scientific and technical role of the contributing expert – illustrating how the boundaries between these categories are blurred.

### **Moral Imagination**

Both radar and the atomic bomb are examples of superordinate goals that are connected to competition with another group – in this case, the Axis powers in World War II. Survival of the Allied nations, and of populations of nations conquered by the Axis powers, was clearly at stake.

Convergent technologies could follow this route – could help one nation or culture gain a military or economic advantage over rivals. Sherif, however, emphasized a kind of superordinate goal that did not involve a common enemy. His campers had to navigate problems with water and food. Access to

food and water are a chronic problem for millions of human beings, but not for all, and those who have abundant supplies do not see ending starvation as a superordinate goal.

The missing element is the ability to see another's suffering as if it were one's own – to see that ensuring no child dies of thirst, or starvation, is a superordinate goal for all. Other potential superordinate goals include increasing affluence and education opportunities for women globally, which would help alleviate population growth (Sen, 1999). The poor represent a potentially huge market for new technologies, because of their sheer numbers (Pralhad and Hammond, 2002).

Trading zones that incorporate these kinds of superordinate goals will require participants to exercise moral imagination. The central tenet of moral imagination is that we learn practical ethics from stories, which become mental models for virtuous behavior (Johnson, 1993). Every culture has mythical tales that illustrate virtues and show the consequences of failing to behave in accordance with them. These stories can be transformed into unquestioned, tacit assumptions that lead myth to be confused with reality. Moral imagination consists of seeing that one's own cultural truths are views, and that alternative views are worth listening to.

Note that this is not relativism. Moral imagination does not assume that all views should be treated equally, just that each perspective is worth at least listening to. Each culture has learned valuable lessons over its history. The hoped-for result of a serious dialogue among different worldviews will be an alternative that is better than any of the originals taken alone. In this sense, moral imagination is like the scientific method. Each of these stories is a hypothesis about how one ought to live in the world, and these hypotheses need to be compared with other hypotheses and evaluated against changing circumstances.

Imagining the future of NBIC convergence requires an explicit consideration of values – of what kind of world we ought to create. Different stakeholders will have different stories, some reflecting hopes, some reflecting fears – like Crichton's *Prey*. These stories need to be informed by the best science. Crichton's swarms, for example, make for dramatic science fiction but are far ahead of anything science can currently imagine (Ratner and Ratner, 2003).

The sacred books and mythologies that date back hundreds of years say nothing about advances in science and technology that have shifted us from the center of the universe to the outskirts of one among millions of galaxies, but that have also given us increased ability to modify our planet and ourselves (Campbell, 1968). NBIC enhancements in human performance will take us closer to abilities reserved for gods in most of our traditional stories. Therefore, decisions about which technological directions deserve public

support, both nationally and internationally, will involve the exercise of moral imagination.

### *Moral Imagination and Genetically Modified Organisms*

When Monsanto took the lead in developing genetically modified organisms (GMOs), the company's story was that this technology would create a new green revolution and would be much easier on the environment (Kilman and Burton, 1999). Instead of spraying chemicals on plants and soil, why not build these capabilities into the plant? Genes from a bacterium were inserted into crops like corn and cotton to produce a pesticide that would eliminate the need for spraying chemicals. Herbicide resistance was added to soybeans and other crops, thereby replacing massive spraying of the soil before the seeds germinated with selected spraying after the plants had emerged (Gorman *et al.*, 2000).

The problem was that Monsanto's story about the benefits of GMOs clashed with alternate stories. Consider Monsanto's attempts to protect its intellectual property (Gorman *et al.*, 2001). Monsanto wanted to prevent reuse and unauthorized distribution of any of its seed. Monsanto's effort to guard against reuse included farmer contracts that allowed the company to inspect fields to make sure there was no reuse, and these inspections irked farmers.

Monsanto also considered adopting a technology developed by Delta and Pine Land and the U.S. Department of Agriculture that would "turn off" a gene after a generation, thereby eliminating the special trait introduced via genetic modification. Farmers, however, particularly in the developing world, regard seed reuse as a right. This "turn off" technology, which would have eliminated the need for inspecting farmer's fields, was labeled "terminator" by the Rural Agricultural Foundation International, a group that now calls for a moratorium on nanotechnology (under the new name ETC).

So Monsanto's story about the benefits of biotechnology was in conflict with stories that put the farmer's rights to reuse seeds ahead of corporate ownership and profit (Pringle, 2003). Monsanto also had difficulties with consumers who wanted GMO foods labeled so that they could choose whether to consume them or not. A vegetarian, for example, might not want to eat any plant that carried a gene originally found in an animal – even though, to a molecular biologist, that gene was just a bit of information, not a piece of pig.

In hindsight, Monsanto might have been able to reach out to stakeholders holding these views, and similarly, those stakeholders could have listened to Monsanto's story. Perhaps it would have been possible to reach agreement on a superordinate goal, like feeding the world's population in a way that increases affluence in developing nations. The Danforth Foundation, working

with Monsanto support, is teaching scientists from the developing world how to develop GMO technologies appropriate to their own natural and cultural environments (Nichols, 2004).

### *Moral Imagination in an Environmental Textile*

Susan Lyons, a New York fashion designer, wanted to create a new fabric for the high-end furniture market that embodied environmental principles. She recruited the architect William McDonough because of his reputation for environmental thinking. He believed that industrial design ought to follow the analogy of nature (Gorman, 1998). All waste in nature becomes food. Similarly, all industrial waste should become food for other products. This could be done in two ways, by having biodegradable products or, where that was not possible, by reusing all materials. In this way, the industrial life cycle would be transformed from cradle-to-grave to cradle-to-cradle.

McDonough brought his collaborator Michael Braungart, an environmental chemist, into the design network. Susan Lyons added a textile manufacturer, Albin Kaelin, who understood McDonough's philosophy and agreed to implement it.

Therefore, this interdisciplinary team adopted a shared mental model based on the concept of waste equals food, and committed to making a furniture fabric via a clean manufacturing process that could be composted at the end of its life.

As long as McDonough's waste-equals-food concept served as the source of a dynamic mental model, this network remained a Stage 3, based on the continuous exercise of moral imagination. Kaelin and Braungart worked particularly hard on alignment: both were careful to bring in suppliers whose practices could be adapted to fit with the principles, staying in close contact with Lyons and McDonough. But if the principle ever degenerates into an ideology, then this network would become a Stage 1, dependent primarily on McDonough as a guru.

This team produced a fabric called Climatex Lifecycle that won numerous awards for environmental design. If this product is to achieve one of McDonough's goals and become a model for a sustainable industrial revolution, the waste-equals-food framework and associated procedures will have to adapt to a complex global system that includes different economic, natural, and technological subsystems (Allenby, 2000/2001).

### **Education for NBIC collaboration**

What kind of education will students need to take part in the development of convergent technologies? Deep knowledge and experience in disciplines like biology, chemistry, computer science, and cognitive science are

essential. Our current educational system is oriented towards this kind of specialist training. However, some students will also need to acquire the interactional expertise necessary to facilitate collaboration across interdisciplinary trading zones. This skill is difficult to foster in the standard graduate curriculum, as we found when we formed a trading zone around a graduate student who incorporated societal dimensions into her nano-technology project. It was not her fault that she had no previous training that prepared her for this kind of collaborative; indeed, she did remarkably well under the circumstances.

Currently, the Accreditation Board for Engineering and Technology (ABET) emphasizes the importance of teaching students to work in multidisciplinary teams (Gorman, 2002b). Convergent technologies create opportunities for students to work in interdisciplinary teams on meaningful problems. Note that interdisciplinary differs from multidisciplinary; the former requires at least some Stage 3 moments, whereas the latter can be effectively managed as a Stage 2 collaboration. NBIC breakthroughs will require the kind of deep exchange that transforms disciplines; therefore, true interdisciplinary collaboration will be required.

Converging technologies represent an excellent way to introduce interdisciplinary collaboration into the curriculum at multiple levels. At the graduate level, it can be encouraged via sharing graduate students across NBIC specialties. Each graduate student would have a core area but could be required to gain interactional expertise in at least one other area, and all students could participate in a core seminar that cuts across NBIC areas on a particular campus, with national workshops that would bring institutions together. This model resembles NSF's Integrative Graduate Education and Research Traineeship (IGERT) program.

At the undergraduate level, there might be one or more integrative seminars that cut across all NBIC areas, but ABET has shown the way with its emphasis on multidisciplinary capstone projects – which should include non-engineering students from cognitive science, ethics, and other fields relevant to a particular project.

At the secondary level, converging technologies might form a theme that will help students link their typically fragmented science and technology courses – fragmented because tests mandated by the states and the federal government mandate coverage of distinct subjects, as do the advanced placement (AP) exams. This kind of integration might be introduced initially as a special activity for gifted students but could spread more widely in a way that complements subject knowledge, reinforcing it by application.

At the middle school level, students often get a broad course on science early on, followed by courses like “life science” or “earth science.” The introductory science course is a great place to introduce convergent

technologies, allowing students to work together to explore linkages among disciplines.

The elementary school curriculum tends to be more integrated and problem-focused; there is not yet a strong division into disciplines. Converging technologies would give upper-level elementary students a chance to think about what kind of future science and technology ought to help us build.

This general sketch of what might be possible at each level needs to be fleshed out into curricular materials, which need to be piloted with the relevant developmental levels in appropriate classroom settings.

Informal education is also a great place to introduce converging technologies – through museums, Internet materials, and other alternatives to the curriculum. Here the value of collaboration would be experienced vicariously, through case studies that involve NBIC researchers working together. It might also be possible to create collaborative simulations online.

Efforts to use converging technologies to stimulate collaboration will depend heavily on educational scaffolding that facilitates the formation of trading zones. Such scaffolding might include

- Reflection diaries (Shrager, 2004) that encourage individuals to monitor the cognitive processes by which they acquire new expertise, including their interactions with those who have other perspectives
- Problem-behavior graphs (Gorman, 1995) and other means of visualizing the group problem-solving process – which could be constructed on the basis of individual reflection diaries and then shown to the interdisciplinary team, fueling a discussion of the way in which they distribute and share knowledge (Fisher and Fisher, 1998).
- Tools that facilitate sharing of data and observations, especially across teams that are not collocated. These tools have to be customizable, so that as collaborators develop a creole and a set of mutually agreeable metrics, the knowledge that needs to be traded can be put in this form. Organizations like the MEMs Exchange can be used as models.

#### *Incorporating Societal Dimensions into NBIC*

The societal and ethical impacts of converging technologies should be part of education at all levels and have the additional advantage of drawing in teachers and students from the liberal arts and humanities, thereby bridging the old “two cultures” gap (Snow, 1963). These societal considerations could help recruit students who want to make the world a better place into science

and engineering, as well as produce policy leaders who understand science and technology.

*An Interactive Simulation of NBIC Policy*

One way to achieve such an integration is to put students into a simulation (Gorman and Rosenwein, 1995) in which they have to make decisions about the future of converging technologies. Let us consider how such a simulation might work for upper-level undergraduates:

- Students from appropriate majors could be placed in research facilities that corresponded to the four NBIC areas. Each of these facilities could have a budget and research mission, and even a record of previous research.
- Another group of students could simulate the NSF, creating a request for proposal (RFP) for funding related to converging technologies, receiving proposals, assigning reviewers, and conducting one or more conferences.
- Another group could represent the Defense Advanced Research Projects Agency, focusing RFPs on military applications like the supersoldier.
- Another group could represent the National Institutes of Health (NIH), with RFPs focused on breakthroughs in human health.
- One group could represent Congress, trying to determine authorizations for the various initiatives and dealing with the executive branch.
- Another group might represent the White House.
- Still other groups could represent companies like IBM, and others could try to form small startup companies.
- Other groups could represent nongovernmental organizations (NGOs) like ETC and Greenpeace that might take a critical stance towards emerging technological frontiers.

Gorman has run two iterations of a simulation of space exploration along these lines on an introductory class for honors engineering undergraduates, including laboratories, companies, federal funding agencies, NGOs, and Congress. A converging technology simulation could vary in complexity and the number of groups, depending on the developmental level of the students and the number engaged. It could be run as a course or as a separate, informal education activity. Members of the groups would have to research the agencies and organizations that corresponded to their roles in the simulation.

## Conclusion

In order for NBIC technologies to converge, we will have to develop better ways of teaching not only disciplinary depth but also interactional expertise. If these technologies are going to represent social as well as technological progress, participants in NBIC trading zones will have to engage in moral imagination. Convergent technologies represent an opportunity to teach students on multiple levels how to collaborate across disciplines and expertises.

## References

- Allenby, B. R. 2000/2001. Earth systems engineering and management. *Technology and Society* 19(4): 10–24.
- Baird, D., and M. Cohen. 1999. Why trade? *Perspectives on science* 7(2): 231–254.
- Campbell, J. 1968. *The Hero With a Thousand Faces* (2nd ed.). Princeton, N.J.: Princeton University Press.
- Close, F. 1991. *Too Hot to Handle: The Race for Cold Fusion*. Princeton, N.J.: Princeton University Press.
- Collins, H. M., and R. Evans. 2002. The third wave of science studies. *Social Studies of Science* 32(2): 235–296.
- Conant, J. 2002. *Tuxedo Park: A Wall Street Tycoon and the Secret Palace of Science that Changed the Course of World War II*. New York: Simon and Schuster.
- Fisher, K., and M. D. Fisher. 1998. *The Distributed Mind: Achieving High Performance through the Collective Intelligence of Knowledge Work Teams*. New York: Amacom.
- Galison, P. 1997. *Image and Logic: A Material Culture of Microphysics*. Chicago: The University of Chicago Press.
- Giere, R. N. (Ed.). 1992. *Cognitive Models of Science* (Vol. XV). Minneapolis: University of Minnesota Press.
- Gorman, M. E. 1995. Confirmation, disconfirmation and invention: The case of Alexander Graham Bell and the telephone. *Thinking and Reasoning* 1(1): 31–53.
- Gorman, M. E. 1998. *Transforming Nature: Ethics, Invention and Design*. Boston: Kluwer Academic.
- Gorman, M. E. 2002a. Levels of expertise and trading zones: A framework for multidisciplinary collaboration. *Social Studies of Science* 32(5): 933–938.
- Gorman, M. E. 2002b. Turning students into professionals: Types of knowledge and ABET engineering criteria. *Journal of Engineering Education* 91(3): 339–344.
- Gorman, M., and R. Rosenwein. 1995. Simulating social epistemology. *Social Epistemology* 9(1): 71–79.
- Gorman, M. E., J. F. Groves, and R. K. Catalano. 2004. Collaborative research into the societal dimensions of nanotechnology: A model and case study. *IEEE Technology and Society Magazine* 23(4): 23–30.
- Gorman, M. E., M. Hertz, and L. P. Magpili. 2000. *Combining Ethics and Design: Monsanto and Genetically-Modified Organisms*. Paper presented at the American Society for Engineering Education, St. Louis, MO.



- Gorman, M. E., J. Simmonds, C. Ofiesh, R. Smith, and P. H. Werhane. 2001. Monsanto and intellectual property. *Teaching Ethics* 2(1): 91–100.
- Helmke, B., and P. F. Davies. 2002. The cytoskeleton under external fluid mechanical forces: Hemodynamic forces acting on the endothelium. *Annals of Biomedical Engineering* 30: 284–296.
- Hughes, T. P. 1998. *Rescuing Prometheus*. New York: Pantheon books.
- Johnson, M. 1993. *Moral Imagination*. Chicago: University of Chicago Press.
- Kilman, S., and T. M. Burton. 1999. Monsanto boss's vision of "life sciences" firm now confronts reality. *Wall Street Journal*, December 21: A1, A10.
- Lambert, M. H., and B. Shaw. 2002. *Transactive Memory and Exception Handling in High-Performance Project Teams*. CIFE Technical Report 137. Palo Alto, Calif.: Stanford University.
- Nichols, T. 2004. *A Study of the Transfer of Genetically Modified Crops from the United States to Kenya*. Undergraduate engineering thesis, University of Virginia.
- Norman, D. A. 1993. *Things That Make Us Smart: Defending Human Attributes in the Age of the Machine*. New York: Addison Wesley.
- Prahalad, C. K., and A. Hammond. 2002. Serving the world's poor, profitably. *Harvard Business Review* 48–59.
- Pringle, P. 2003. *Food, Inc. Mendel to Monsanto – The Promises and Perils of the Biotech Harvest*. New York: Simon and Schuster.
- Ratner, M. A., and D. Ratner. 2003. *Nanotechnology: A Gentle Introduction to the Next Big Idea*. Upper Saddle River, N.J.: Prentice Hall PTR.
- Rejeski, D. 2004. The Next Small Thing. *The Environmental Forum* 42–49.
- Sen, A. 1999. *Development as Freedom*. New York: Random House.
- Sherif, M. 1967. *Social Interaction*. Chicago: Aldine.
- Shrager, J. 2004. Diary of an insane cell mechanic. In M. E. Gorman, R. D. Tweney, D. C. Gooding and A. Kincannon (eds.), *Scientific and technological thinking*. Mahwah, N.J.: Lawrence Erlbaum Associates.
- Snow, C. P. 1963. *The Two Cultures and a Second Look*. New York: Cambridge University Press.
- Thorpe, C., and S. Shapin. 2000. Who was J. Robert Oppenheimer? *Social Studies of Science* 30(4): 545–590.

## 7. IF WE BUILD IT, WILL THEY COME? THE CULTURAL CHALLENGES OF CYBERINFRASTRUCTURE DEVELOPMENT

Thomas A. Finholt and Jeremy P. Birnholtz, University of Michigan<sup>1</sup>

*Abstract:* In this chapter, we show how Hofstede's cultural constructs help explain the dysfunction we observed in the early history of the George E. Brown, Jr., Network for Earthquake Engineering Simulation (NEES), a large-scale deployment of cyberinfrastructure intended to link 16 experimental facilities around the United States. The NEES project involved participants from three distinct professional cultures: civil engineering, computer science, and program managers at the U.S. National Science Foundation. Using Hofstede's categories, we demonstrate how miscommunication arose from orthogonal orientations on Hofstede's dimensions. In particular, we found that variation in attitudes toward risk led to conflict, with the more risk-averse civil engineers and program managers frequently aligned against the more risk-tolerant computer scientists. In the discussion, we consider successful techniques for accommodating differences in professional cultures and offer a set of lessons learned based on experience with the NEES project.

### Cyberinfrastructure and the “Third Way”

The convergence of information technology and research, in what some have called “cyberscience” (Nentwich, 2003), represents a potentially revolutionary change in the conduct and organization of scientific inquiry. Specifically, recent expert reports, such as by the National Science Foundation's blue-ribbon panel on cyberinfrastructure (Atkins *et al.* 2003), suggest that advances in computing and networking may transform intellectual work in ways similar to the transformation of physical work that occurred during the Industrial Revolution. That is, just as innovations in physical infrastructure unleashed new forms of production and distribution, innovations in cyberinfrastructure are expected to foster new discoveries based on the ability to capture and analyze more data at increasingly higher resolution, to generate simulations with greater detail and accuracy, and to interact and collaborate with colleagues independent of time and distance.

In particular, noting the theme of this collection around “converging technologies,” it is important to emphasize that to a great extent, the

---

<sup>1</sup> We are grateful for the assistance and advice from our colleagues on the NEESgrid project, particularly that of Randy Butler, Joseph Hardin, Dan Horn, Chuck Severance, and Bill Spencer, and for the insights shared by the members of the earthquake engineering community.

transformative power of cyberinfrastructure lies in its potential to bring multiple scientific or engineering disciplines together. Sometimes these unions become the basis for new, converged disciplines such as the emergence of computational biology and chemistry around the combination of these traditional fields with computer science (e.g., simulations of molecular dynamics or visualizations of chemical structures). However, disciplinary convergence is not an automatic result of cyberinfrastructure. As this chapter illustrates, there are still critical challenges to convergence in the form of underlying socio-technical factors, such as the differences in work practices and world views that complicate the relationship between users and developers of cyberinfrastructure.

Observing an earlier period, when dramatic changes in the organization of scientific work produced new convergence, Sir Humphrey Davy noted: “Nothing tends so much to the advancement of knowledge as the application of a new instrument.” (Hager, 1995: 86). Of course, Davy was referring to his own voltaic pile and similar inventions, which were both the source of key discoveries (e.g., identification of new elements) and the cause for the emergence of new organizational forms (e.g., the professional laboratory, such as the Royal Institution, which Davy founded). Today, cyberinfrastructure is a new kind of instrument, in the sense that through high-performance computing and networking, scientists are able to generate data and test hypotheses beyond the limits of traditional theory or experiment-based approaches. Specifically, in the words of the Atkins report, computational simulations provide a “third way” to do research at unprecedented levels of temporal and spatial fidelity. For example, visualizations of weather models run on supercomputers can provide atmospheric scientists with virtual perspectives on large-scale systems, such as tornadoes emerging from storm cells.

### **Barriers to Cyberinfrastructure**

The capacity to use cyberinfrastructure to instrument phenomena *in silico* is expected to accelerate the pace of scientific discovery and of innovation based on these discoveries. Yet a number of barriers exist that may limit this potential. A key obstacle is the availability of funds. For example, federal sponsors are expected to play a central role in making the lead investments in cyberinfrastructure that will signal the need for subsequent larger investments from other sectors, such as industry and academia. One model for this evolution is NSFnet, in which a relatively modest level of funding from the National Science Foundation (NSF) was leveraged by significant contributions from universities and corporations, with the result being the birth of broadly interoperable networks around the TCP/IP standard adopted within NSFnet. The Atkins report calls for the NSF

to make a \$1 billion lead investment in cyberinfrastructure. Given current budget levels, such as the essentially flat appropriation for NSF in the FY 2005 federal budget, it seems unlikely that anything approaching the scope of the Atkins report recommendations will be carried out soon. However, NSF did recently create the new division of shared cyberinfrastructure (SCI) within the computing and information science and engineering (CISE) directorate, which has on the order of \$120 million to fund cyberinfrastructure awards. In addition, several directorates have identified existing funding, sometimes totaling several hundred million dollars, in cyberinfrastructure-related programs, such as the George E. Brown, Jr., Network for Earthquake Engineering Simulation (NEES), an \$89 million collaboratory funded by the engineering directorate. A collaboratory is a form of cyberinfrastructure that brings together resources (e.g., instruments), people, and data via computer-supported systems (Finholt, 2003).

NEES began in 2001, and during the development phase (2001-2004) it consisted of three elements. First, the majority of resources went to construct new earthquake engineering (EE) facilities at 15 institutions. Figure 1 shows the location and capabilities of these new labs. Second, \$10 million went to a consortium led by the National Center for Supercomputing Applications at the University of Illinois to develop NEESgrid, the cyberinfrastructure to link the new labs. Finally, \$3 million went to the Consortium for University Research in Earthquake Engineering to build and launch the NEES Consortium, Inc., or the nonprofit entity that NSF would fund over the period 2004-2014 to maintain and operate the NEES systems. As of October 1, 2004, operational control over NEES passed to the NEES Consortium, and the grand opening ceremony for NEES was held on November 15, 2004.

Our role in the NEES program was to investigate and enumerate the user requirements for NEESgrid. Thus, we were an interface between the earthquake engineers (the target users of the system), the NSF program managers (the customer), and the computer scientists (the system developers). In the process of gathering user requirements during the period 2000–2003, we attended 10 national meetings and workshops of engineers and system developers, as well as six site reviews of the project by an independent panel, and also participated in weekly videoconferences on the progress of the project with engineers, developers, and program managers. We have also visited the 15 NEES equipment sites and conducted over 75 interviews with earthquake engineers, as well as conducted four national surveys of communication and collaboration practices within the EE community. Through these activities, we had many opportunities to observe key participants in the NEES program and to catalog various breakdowns of communication and trust.



### **Cultural Orientation**

In his famous analysis, Hofstede (1980, 1991), proposed four fundamental dimensions that reliably differentiate national cultures: uncertainty avoidance, power distance, gender, and individualism. With some modest adjustment, these same dimensions can be used to describe differences in what might be called “professional cultures.” Professional cultures are to people who work and were socialized in different fields of work as national cultures are to people who live and were socialized in different countries. In this case, we argue that the NEES project brought together participants from three areas of work, each with its own unique professional culture: earthquake engineers, who were the target users of the NEES cyberinfrastructure; NSF program managers, who were the principal “customers” for the delivered systems (both facilities and cyberinfrastructure); and computer scientists, who were the cyberinfrastructure developers. Despite broad endorsement of NEES by all participants, early interactions between the main groups were problematic and quickly led to mistrust.

Difficulties in NEES had the character of a “first contact” gone awry. That is, in accounts of European exploration in the New World (e.g., Ruby, 2001), a recurring theme is the inability of the Europeans to step outside their own cultural framework – with one result being a history of disastrous relations with native populations. Similarly, in the NEES project, representatives of the three key groups entered their initial collaborations assuming a common worldview. Subsequent discovery of divergent perspectives was initially a cause of communication failures and later the basis for open hostility. Hofstede’s dimensions, when applied to the professional cultures represented in NEES, provide a helpful starting place for understanding why the start of the NEES project was so hard, and also why changes to the project over time eventually corrected some of the early problems and increased the likelihood of success.

Whereas Hofstede provides four dimensions on which cultures can be distinguished, we found two of these to be particularly relevant in characterizing the early NEES participants – uncertainty avoidance and power distance. Uncertainty Avoidance is the extent to which individuals take steps to control risk and the unknown. Power Distance is the extent to which individuals prefer formal and hierarchical relationships compared to more informal and egalitarian relationships. The sub-sections below characterize each type of NEES participant according to these two dimensions, with particular attention to how groups differed and how these differences led to negative consequences for project development.

*Earthquake Engineers*

Earthquake engineering (EE) is concerned with the seismic performance of the built environment (Sims, 1999). Their research work typically consists of experiments conducted on large, physical models of buildings, bridges, and soil-retaining structures (e.g., retaining walls, building foundations, etc.) that are outfitted with hundreds of sensors that record details of strain and motion in simulated earthquakes generated by means of large shaking platforms or hydraulic actuators. EE as a field reflects some degree of convergence, to the extent that researchers must understand both characteristics of ground motion related to seismic activity and the effects of this ground motion on buildings and other physical infrastructure. In addition, researchers typically combine analytic activity with experimental activity, such as computational simulations conducted to determine the range of behavior for a specimen that will be tested in a physical simulation. For the most part, however, EE researchers tend to be trained as civil engineers (and most are certified as professional engineers) and tend to apply computational simulations in support of physical simulations (rather than as substitutes, which is to say that there is not yet any analog in EE research for the computationally based subdisciplines that have emerged in other fields, such as computational chemistry or biology).

*Uncertainty Avoidance.* Earthquake engineers generally seek to avoid or control uncertainty. Experimental specimens in EE are typically built of steel or reinforced concrete, as are the “real-world” structures that these specimens represent. Such materials are difficult to modify once constructed, and there is therefore a tremendous amount of planning and analysis that goes into the design of an experimental specimen. Uncertainty, and the accompanying potential for changes, errors, and unpredictable structural behavior, is thus seen as a significant potential liability in this community and is actively avoided. This risk aversion in experimental work is indicative of a generally conservative orientation among earthquake engineers that makes them suspicious of tools and methods that are new and untested.

*Power Distance.* EE is generally distinguished by high power distance. Among earthquake engineers, there is a tendency to defer to authority figures both within local laboratories and in the field more generally. Power distance is reflected at the field level in the distribution of experimental apparatus. A small number of large-scale facilities define a clear set of elite institutions that are better ranked (e.g., by the National Research Council), publish more, obtain more funding, and attract better graduate students. At the local level, power distance is reflected in the division of labor in the laboratories, with some tasks clearly intended for undergraduate lab assistants versus graduate students versus technicians and faculty. In addition, graduate students work

primarily on projects initiated and led by their advisors, rather than on projects they devise independently.

#### *Cyberinfrastructure Developers*

The NEES cyberinfrastructure development effort was based on a number of open source software codes, notably those needed to enable “grid-based” systems (Foster and Kesselman, 1999). As a result, although not strictly an open source project, NEES developers did resemble open source programmers described elsewhere, such as in DiBona, Ockman, and Stone (1999). In other words, they exhibited an egalitarian orientation with a preference for informal organization.

*Uncertainty Avoidance.* The cyberinfrastructure developers were not risk averse and can therefore be characterized as low on the uncertainty avoidance dimension. Specifically, the developers worked using spiral software development models (Boehm, 1995) that advocated rapid iteration and prototyping. Such a strategy actively encourages risk-taking and sometimes ill-specified development activities because it is assumed that problems can be eliminated in the next iteration, which is never far away and does not have a high cost. Thus, there was little perceived need to eliminate uncertainty early in the project, as errors were expected and would be addressed in the subsequent development cycles. This is captured well in one of the NEES software developers’ frequent use of the motto “don’t worry, be crappy” to describe the incremental approach to risk inherent in the spiral model.

*Power Distance.* Power distance among cyberinfrastructure developers was low. Individual programmers often had broad latitude to determine how to proceed with development, provided they remained consistent with overarching design directions. Further, in interactions among the developers, people participated largely independent of their status or seniority, with the exception of sometimes deferring to others with deeper technical expertise.

#### *NSF Program Managers*

Program officers in the NSF are responsible for overseeing the distribution and management of resources in ways that promote the goals of the Foundation. With much grant-based research, this tends to be accomplished via a reasonably “hands-off” approach. NEES, however, differed from typical grants in critical respects. First, NEES was a high-profile project in terms of funding level and was awarded as a “cooperative agreement,” which imposed a higher than typical oversight burden on NSF. Second, NEES was the first major research equipment and facility construction project in the engineering directorate. Finally, NEES was the



first attempt by NSF to build a network of facilities linked by cyberinfrastructure.

*Uncertainty Avoidance.* Uncertainty avoidance was high among the NSF managers. First, many came from the EE and civil engineering cultures and shared the pervasive risk aversion of colleagues from these communities. Second, because of the cost and visibility of NEES, the stakes were quite high for individual managers, particularly in terms of career advancement.

*Power Distance.* Power distance among the NSF managers was high. That is, particularly because of the cooperative agreement governing NEES, NSF managers intervened more actively in the conduct of the project. Because this differed from the usual experience with grant-based research, NEES investigators chafed under the closer scrutiny of the NSF staff. For example, rather than the collegial relationship characteristic of grant-based activity, the cooperative agreement created a hierarchical relationship. In some cases, particularly around NSF requests for documentation and justification, NEES investigators felt they were treated as subordinates – or mere contractors – rather than as leading researchers in computer science or earthquake engineering.

### **Consequences of Cultural Differences**

One episode that illustrated the gulf between earthquake engineers and cyberinfrastructure developers emerged around the release of the initial user requirements report by the cyberinfrastructure development team. The report, grounded in the principles of user-centered design and based on substantial interview and survey data, outlined at a high level the comprehensive user requirements for the NEESgrid collaboratory. The earthquake engineers were almost universally disappointed with the user requirements report. Specifically, the earthquake engineers and the cyberinfrastructure developers had divergent notions of what constituted “requirements” that at least partially reflected differences in their professional cultures.

The engineering notion of requirements was specific with detailed characterization of functionality, implementation, and relationship to other requirements. This approach to user requirements was consistent with both the engineers’ cultural bias against uncertainty and their preference for formal and hierarchical relationships. That is, a precise and exhaustive requirements document early in a project allows for elimination of potential problems and for clear division of labor. The cyberinfrastructure developers, in contrast, had a less rigid view of requirements. The spiral development model they adopted suggested that it would be difficult or impossible to resolve all uncertainties early on, so the best approach was to specify requirements at a high level, implement to satisfy these initial requirements, and then iterate to improve both requirements specification and

implementation. This approach struck the earthquake engineers as sloppy and unnecessarily risky. Differences about the meaning of requirements served to create a rift between the developers and earthquake engineers, because neither side believed the other knew what “requirements” were or how to correctly document them. This fostered mistrust and vastly increased the need for communication and bridge-building between the communities.

Another episode that underlined the difficulty of negotiating cultural differences among the NEES players was the “emergency all-hands meeting” convened by NSF program managers just a few months after the project began. The primary issue at this meeting was a misunderstanding over the nature of project deliverables. The cyberinfrastructure developers argued that they had received funding to produce a set of grid-based telecontrol protocols and Application Program Interfaces (APIs) for integrating equipment at different laboratories and for providing telepresence functionality. The earthquake engineers, and to some extent the NSF program managers, thought they were getting a turnkey system, and were shocked to learn that they would have to hire programmers and learn to use APIs in order to make the NEES system functional. After one long discussion in which the computer scientists fended off a growing list of deliverables as “out of scope,” a disgusted earthquake engineer observed of the cyberinfrastructure developers that “we wouldn’t buy a used car from you guys” – reflecting the sense that the engineers had been sold a “lemon.”

Again, this conflict can be explained along cultural lines. The desire of the earthquake engineers to avoid costly uncertainty explains the extent to which they bristled at the surprising discovery of what they perceived as the deficient scope of the cyberinfrastructure development activity. Similarly, the response of the cyberinfrastructure developers reflected their cultural orientation toward maintaining flexibility to address interesting issues as they arose, rather than being firmly committed to carry out tasks that might prove to be dead ends or time sinks. One measure of the cultural disconnect between the two sides was that at this meeting, and other subsequent sessions, the computer scientists brushed off the engineers’ concerns (often using humor), not realizing the growing irritation on the part of the engineers. Specifically, at a moment when both sides needed to develop common ground, their cultural dispositions caused them to dig in and oppose each other.

### **Discussion and Lessons Learned**

This chapter highlights professional culture conflict as a previously undocumented source of risk in cyberinfrastructure initiatives. That is, because cyberinfrastructure involves the blending of effort between computer scientists and one or more communities of domain scientists or engineers,

there is a greater than normal chance for misunderstanding and mistrust arising from cultural differences. Further, because of the cost and visibility of cyberinfrastructure projects, federal program managers typically represent a third cultural perspective, one that is often at odds with the other perspectives. As the preceding sections have shown, failure to understand and accommodate cultural differences can result in awkward first contacts, and subsequent difficulty in building understanding and confidence among participants from separate professional cultures. In this section we describe some of the steps taken to overcome cultural barriers in the NEES project and then use these experiences to describe a general set of lessons learned that can help other cyberinfrastructure efforts avoid repeating the NEES mistakes.

#### *Strategies Adopted to Overcome Cultural Differences*

After a problematic start to the NEES development and deployment, key players from each of the participating groups explored and adopted strategies to help overcome cultural differences. First, there was general agreement that all parties needed more opportunities to communicate. One important step, therefore, was taken halfway through the first year of NEES development, when cyberinfrastructure developers, earthquake engineers, and NSF program managers agreed to convene a weekly, multi-point videoconference (Hofer *et al.*, 2004). The format of these conferences allowed for the presentation and discussion of a specific concern each week, along with some time for general discussion. Responsibility for these meetings was traded off between the earthquake engineers and the cyberinfrastructure developers. These weekly conferences were widely viewed as being tremendously helpful in getting the NEES project participants to understand each other better.

A second strategy for overcoming cultural differences involved explicit efforts to increase the diversity of involvement in cyberinfrastructure development. For the first 2 years, the project directors for the NEES collaborative effort were closely aligned with the cyberinfrastructure developer culture. Because of the strained relations that emerged between the earthquake engineers and the cyberinfrastructure developers, the lack of a strong earthquake engineering voice in the development process became a focus for criticism from both earthquake engineers and the NSF program managers. Therefore, shortly before the start of the final year of the project there was a leadership change. A prominent earthquake engineer who had a strong relationship with all of the communities involved was selected to lead the NEES collaborative effort, and this had a positive impact on relations between the participating groups. In particular, the new project director was able to serve as a translator, effectively smoothing over many of the misunderstandings and the mistrust that had emerged early in the project.

*Lessons Learned from the NEES Experience*

We believe the experience with NEES, during the period 2001–2004, offers a set of general lessons that can be applied to other cyberinfrastructure projects. The following list represents our recommendations for subsequent cyberinfrastructure efforts.

- Lesson 1: A domain scientist or engineer must be a leader or co-leader of cyberinfrastructure development and deployment. This does not mean that technology experts should be pushed aside but, rather, that the best insurance against an overly ambitious technological agenda is the presence of a domain scientist or engineer to consistently enforce attention to documented user requirements. In the Atkins report (2003), this tension is identified as the strain between the desire of cyberinfrastructure developers to pursue novel computer science research against the need by domain scientists and engineers to have reliable production environments.
- Lesson 2: Where possible, project participants should err on the side of clarifying and mitigating sources of uncertainty. This does not mean that cyberinfrastructure development should avoid risk or that all risks must be enumerated in advance. However, all parties should develop a common understanding of how to approach and manage risk. For example, as much as academic computer scientists may chafe under constraints imposed by formal project management, articulating precise deliverables and timelines is a critical way to create shared expectations across cultural divisions. Of course, having identified critical deliverables, it is essential that these be accomplished on schedule – particularly as parallel streams of work (e.g., collaboratory development and facility construction) often involve complicated dependencies.
- Lesson 3: Communication about project status must be regular, frequent, across multiple levels, and via multiple media. A quarterly or semiannual “all hands” meeting is not sufficient for handling the complexity that arises in a cyberinfrastructure project. Similarly, exclusive communication through electronic means (e.g., e-mail) increases the likelihood of misinterpretation – particularly early in a project. Instead, projects should encourage a number of ways to communicate, both formal and informal. Travel funds should be spent to encourage frequent face-to-face contact, especially during start-up phases. The ability to associate a face and a friendly relationship with a name that otherwise appears only in one’s e-mail in-box often protects against harsh attributions that can arise between participants from different professional cultures.

- Lesson 4: There should be frequent and public affirmation of project accomplishments at venues and conferences that are important to all participating groups. For instance, in the NEES project critical technology demonstrations were conducted at meetings attended primarily by computer scientists, such as the annual supercomputing conferences, but also at meetings significant to earthquake engineers, such as the World Conferences on Earthquake Engineering, held every 2 years. These public demonstrations create a development discipline that focuses attention on integration and functionality in a way that all participants can understand and evaluate.

### **Implications for NBIC Convergence**

We believe that the situations, experiences, and lessons from NEES are instructive when considering the convergence between nanotechnology, biology, information technology, and cognitive science (NBIC). That is, the form of cultural conflict between these fields may be different than what we observed with NEES, but we are confident that the unique disciplinary identities represented when bringing together the NBIC fields will require the same kind of explicit measures that we saw adopted within the NEES project. One difference that may distinguish NBIC convergence from the NEES case is the greater exposure and use of high-performance computing and visualization in these fields, compared to in earthquake engineering. This exposure may be both a benefit and a source of problems. On the positive side, deep experience and use of cyberinfrastructure by NBIC researchers may leave them more willing to consider and adopt innovative cyberinfrastructure. For example, labs that rely on advanced simulations and visualizations probably already have the hardware, software, and staff needed to support exploration of other cyberinfrastructure applications. On the negative side, though, overconfidence in technological solutions may result in under-appreciation of socio-technical factors that can influence the health and productivity of a collaboration. In particular, a recent NSF report by Cummings and Kiesler (2003) expresses doubt about the relative merit of some collaboration technologies versus explicit coordination practices in determining the success of geographically dispersed interdisciplinary research teams. That is, in many cases the establishment of norms and procedures for communication (even if this only involves a simple weekly meeting via phone conference) may be more critical than adoption of the latest technologies (e.g., immersive virtual environments, high-resolution videoconferencing, or ubiquitous computing).

## References

- Atkins, D. E., K. Droegemeier, S. Feldman, H. Garcia-Molina, M. L. Klein, D. G. Messerschmitt, P. Messina, J. P. Osriker, and M. H. Wright. 2003. *Revolutionizing Science and Engineering Through Cyberinfrastructure*. Arlington, Virginia.: National Science Foundation.
- Boehm, B. W. 1995. A spiral model of software development and enhancement. In R. M. Baecker, J. Grudin, W. A. S. Buxton, and S. Greenberg (eds.), *Human Computer Interaction: Toward the Year 2000*. San Francisco, Calif.: Morgan Kaufman.
- Cummings, J., and S. Kiesler. 2003. *KDI Initiative: Multidisciplinary Scientific Collaborations*. Arlington, Virginia.: National Science Foundation.
- DiBona, C., S. Ockman, and M. Stone. 1990. *Open Sources: Voices from the Open Source Revolution*. Cambridge, Mass.: O'Reilly.
- Finholt, T. A. 2003. Collaboratories as a new form of scientific organization. *Economics of Innovation and New Technologies* 12(1): 5–25.
- Foster, I., and C. Kesselman. 1999. *The Grid: Blueprint for a New Computing Infrastructure*. San Francisco, Calif.: Morgan Kaufmann.
- Hager, T. 1995. *Force of Nature*. New York: Simon and Schuster.
- Hofer, E.C., T. A. Finholt, J. Hajjar, and A. Reinhorn. 2004. The Internet2 commons: Supporting distributed engineering collaboration. *Syllabus Magazine* (January).
- Hofstede, G. 1980. *Culture's Consequences*. Newbury Park, Calif.: Sage Publications.
- Hofstede, G. 1991. *Cultures and Organizations: Software of the Mind*. London: McGraw-Hill.
- Nentwich, M. 2003. *Cyberscience: Research in the Age of the Internet*. Vienna, Austria: Austrian Academy of Sciences Press.
- Ruby, R. 2001. *Unknown Shore: The Lost History of England's Arctic Colony*. New York: Henry Holt.
- Sims, B. 1999. Concrete practices: Testing in an earthquake engineering laboratory. *Social Studies of Science* 29(4): 483-518.

## 8. CONVERGING TECHNOLOGIES IN DEVELOPING COUNTRIES: PASSIONATE VOICES, FRUITFUL ACTIONS

*Jim Hurd, Director, NanoScience Exchange*

*Abstract:* The challenge we face today in creating technologies for the developing world is not in having great ideas, but in being flexible and dedicated enough to make sure that some version of a technology insight actually gets adopted by people in developing countries. Success requires the heroic efforts of passionate people who act very effectively upon their passion. This chapter considers what such technology entrepreneurs have already accomplished and what they are ready to accomplish in the short-term and longer-term future. Examples cover a wide range of converging technologies, across infotech, nanotech, biotech, and cognotech. The essay urges scientists, engineers, and entrepreneurs to work together passionately, using the power of converging technologies to move forward, to keep our humanity alive, to help the world to live, grow, and adapt.

### Introduction

Converging technologies can promote world unity, the convergence of humanity itself, but only if individuals take responsibility for promoting progress in responsible and practical ways. What is the definition of the word “technology?” Webster’s says it is “the application of knowledge for practical ends.” The pencil, the locomotive, the atomic bomb, and the Internet are all “applications of knowledge.” We need to understand that technology can take any shape or form, and is often becoming invisible – yet highly effective, embedded into an everyday appliance. To me, the term technology is used any time one applies a specific technique – a technique that achieves a tangible result for us.

The challenge we face today in creating technologies for the developing world is not in having great ideas, nor in seeing promising ideas get some funding. The challenge we face is in having a technology insight and then being flexible and dedicated enough to make sure that some version of the solution actually gets adopted and used by people in developing countries. Progress is not about great technology. It’s about getting real results, any way you can.

Dean Kamen, the inventor of the Segway, has said, “Providing real productivity tools to people living in places where there is little or no productivity not only improves their quality of life but also vastly improves their local economy, as well as the world economy. That’s good business, not altruism. And we can do it now” (Kamen, 2003).

Change happens because people translate ideas into action. It takes heroic efforts of people who are passionate, and who act very effectively upon their passion – people like Paul Meyer, Lee Thorn, Kofi Annan, Bill Gates, Kamran Elahian, and Barbara Waugh, as we will see below. They would say they are not heroes, that they are just working to solve problems that desperately need solving, so that people can live human lives, with a bit of hope, with a little less desperate suffering. These heroes move us forward, they keep our humanity alive, and they help the world to live and grow and adapt. Without these heroes, we would be lost.

### **Accomplishing Change**

Claude Leglise, Director of International Investments for Intel Capital, says:

In a global economy, with no trade barriers, the basis of health and wealth is brain power. Manufacturing is following the same path as agriculture. Therefore a better life can only come from new ideas.

I believe the vibrancy of a country is a function of its intellectual wealth. In turn, its material well-being is based on its ability to turn that intellectual wealth into economic wealth. Many emerging countries are well on their way towards developing world class intellectual wealth. The trick is to enable economic development.<sup>1</sup>

From a global perspective, we see India as a leader in enterprise software and networking technologies. We see wireless and telecom solutions coming out of Finland, England, and Israel. Banking software comes out of Brazil. Intel Capital has invested in start-ups worldwide, as part of the \$4 billion it has spent since the early 1990s. It now ranks as the world's leading venture capital firm. Most of that investment has been made in U.S. companies, but a substantial percentage is invested outside the United States, in Europe, Israel, Russia, and elsewhere. In Russia, Intel has been investing as that country builds its technology leadership in the following areas: material science that creates breakthrough crystals that can lead to new display and semiconductor technologies; computer programming expertise, particularly in designing powerful software algorithms by Russian math whizzes; and radio technology for wireless communications.<sup>2</sup>

Change is not always slow. It's all about the chemistry of a specific technology and the tangible benefit it brings to users. Sometimes the change

---

<sup>1</sup> Claude Leglise presentation to Silicom Ventures in Mountain View, California, November, 2003.

<sup>2</sup> *Business Week*, June 23, 2003.



is slow; sometimes the adoption is surprisingly fast. Wireless phone adoption in countries like China and India has been breathtakingly fast.

In developing countries, an especially powerful mode of development is viral adoption, a process in which an innovation that starts small diffuses rapidly throughout a community, like a healthy contagion, gaining strength, value, and the ability to grow farther with every additional individual who joins.<sup>1</sup> A sterling example of an economic trailblazer is the Grameen Bank, which grew out of an action research project started in 1976 by Professor Muhammad Yunus of the University of Chittagong in Bangladesh to design a new credit delivery system for poor people in rural areas. As the bank's Web site says today, "we never imagined that some day we would be reaching hundreds of thousands, let alone three million, borrowers. But the capabilities and commitment of our staff and borrowers gave us the courage to expand boldly. We hardly noticed that we reached milestones like 100,000 borrowers, \$1 billion lent, \$2 million borrowers and so forth. Everyone predicted that the quality of the services we provided would deteriorate when we reached large numbers; yet, in reality, in many ways it improved."<sup>2</sup>

The ability of Grameen Bank to lease a wireless phone to poor women in small towns in places like rural India – women who use that phone to run a business where other villagers can pay to make calls – was a huge success for all parties involved. After graduating with a Ph.D. in economics from Harvard University, Muhammad Yunus said he needed to unlearn everything taught him there in order to build programs that would succeed in the developing world.

On November 5, 2002, the Secretary-General of the United Nations, Kofi Annan, challenged Silicon Valley technologists to "define an inclusive, long-term vision . . . that matches investment opportunities with the real needs of the poor," based in private–public partnerships, so that the entire world could benefit from information and communication technologies. In his own career, Annan connected developing societies with advanced industrial society, and technology with economics.

Born in Ghana in 1938, Annan attended the University of Science and Technology in Kumasi before studying economics in the United States and Switzerland, and then earning a master's degree in management from the Massachusetts Institute of Technology.<sup>3</sup> In accepting the 2001 Nobel Peace Prize, he proclaimed:

Today's real borders are not between nations, but between powerful and powerless, free and fettered, privileged and humiliated. Today, no walls can separate humanitarian or human rights crises in

---

<sup>1</sup> [dl.media.mit.edu/viral/viral.pdf](http://dl.media.mit.edu/viral/viral.pdf)

<sup>2</sup> [www.grameen-info.org/agrameen/](http://www.grameen-info.org/agrameen/).

<sup>3</sup> [www.un.org/News/press/docs/2001/sg\\_biography.html](http://www.un.org/News/press/docs/2001/sg_biography.html).

one part of the world from national security crises in another. . . . In the 21st Century I believe the mission of the United Nations will be defined by a new, more profound, awareness of the sanctity and dignity of every human life, regardless of race or religion. This will require us to look beyond the framework of States, and beneath the surface of nations or communities.<sup>1</sup>

The Millennium Development Goals, developed by the U.N, are an ambitious agenda for reducing poverty and improving lives that world leaders agreed to at the Millennium Summit in September of 2000 (General Assembly, 2000; United Nations Development Group, 2003). Most of the goals have been set to be reached by 2015:

1. Eradicate extreme poverty and hunger
2. Achieve universal primary education
3. Promote gender equality and empower women
4. Reduce child mortality
5. Improve maternal health
6. Combat HIV/AIDS, malaria, and other diseases
7. Ensure environmental sustainability
8. Develop a global partnership for development.

### **Short-Term Future: Ecosystem of Start-Ups, Foundations, and Corporations**

Today, visionary individuals and organizations are making a heroic difference, bringing to reality the hopes of people in developing countries. There is a powerful ecosystem of participants, including start-ups, foundations, and corporations. Excellent examples include Voxiva, ApproTEC, the Jahai Foundation, the Gates Foundation, Kamran Elahian, and Hewlett Packard.

#### *Start-Ups: Voxiva – Real-Time Reporting of Infectious Diseases*

Voxiva is an infotech company, whose role is “pioneering voice/data solutions to improve health and safety worldwide.”<sup>2</sup> Paul Meyer, the founder of Voxiva, was, at age 23 years, a speechwriter for President Clinton. Meyer says the job helped him learn “how to mobilize people, how to convince people to do new things, how to talk people into doing things that are against their better judgment, and how to not take no for an answer.” When he left the White House, he went to Yale Law School. After graduating, he founded

---

<sup>1</sup> [nobelprize.org/peace/laureates/2001/annan-lecture.html](http://nobelprize.org/peace/laureates/2001/annan-lecture.html).

<sup>2</sup> [www.voxiva.net/](http://www.voxiva.net/).

IPKO (Internet Projekti Kosova), which was the first and largest provider of Internet access in Kosovo, enabling individuals to find their lost family members (Fisher, 2000): “Ordinarily recent graduates of Yale Law School spend more time tinkering with contracts in corporate boardrooms than messing with faulty computers and generators in one of the world’s most dangerous places, Kosovo. But Meyer is nothing if not unusual. He has spent the past two years using digital technology to bring together people in desperate straits, getting things done while others were pontificating” (Reingold, 2001: 124).

Meyer, who understands the power of technology, decided to use a very low-tech tool, the phone, when he started Voxiva. The company enables health care workers to report infectious diseases in real-time by keying in number codes over the phone. Previously, it took weeks or months for this key information to be collected by paper and brought to a central station. In rural areas of developing countries, a pay phone is often a community’s only link to the outside world. Voxiva’s technology turns the pay phone into a more powerful communication device. By using the world’s 2.5 billion phones, in addition to computers, Voxiva has a much wider reach.

Voxiva is used in Rwanda, Peru, Iraq, India, and also in the United States by such clients as the San Diego County Health Department, the Food and Drug Administration, and the Department of Defense. Paul is working to demonstrate that good works can be good business. Voxiva has received investment from a variety of investors because the company is showing that it can also produce solid profits.

#### *Start-Ups: ApproTEC – Tools that Build Economies*

ApproTEC is a nonprofit organization that develops and markets new technologies in Africa that are effective tools for building economies. The name is derived from E. F. Schumacher’s (1973) concept of appropriate technologies, which often may not be the technologies most favored in economically advanced nations but are best designed to achieve progress in a developing country. These low-cost technologies are bought by local entrepreneurs and are used to establish highly profitable new small businesses: They create new jobs and new wealth and allow the poor to climb out of poverty.

The treadle pump, one of the company’s best-known products, is operated with pedals, something like a Stairmaster. This device allows a farmer to sharply increase the water he can use to irrigate crops. ApproTEC’s distribution of the treadle pump and other projects has been credited with raising the gross domestic product of Kenya by \$40 million, or 0.5 percent, each year. “Raising living standards to levels where people can think about things beyond keeping themselves alive from day to day is a critical part of

how to solve the sustainable development puzzle,” said Eric Lemelson, when the Lemelson Foundation gave ApproTEC a \$100,000 grant in 2003 (Riordan, 2004).<sup>1</sup>

ApproTEC cites Jane Mathendu as a good example of success: “Jane Mathendu is a single mother who lives near Mt. Kenya. In 1998 she bought an ApproTEC oilseed press to start a new business. She now contracts 20 local farmers to grow sunflowers, employs 2 full time workers and sells the cooking oil in the local market. The new business has changed Jane’s life. She has become a local opinion leader and paid for her daughter’s university education – an impossible dream before buying her new press” (cf. Schwab Foundation, 2003: 5).<sup>2</sup>

*Foundations: Jhai Foundation and the Jhai PC*

The Jhai Foundation, whose name means “hearts and minds working together” in Laotian, has developed a bicycle-powered Internet computer for Laotian Farmers.<sup>3</sup> Villagers in the mountainous jungles of northern Laos made it clear to Lee Thorn that what they needed most was access to information – information on what prices the market was paying for their crops, and in particular their rice. The best way to get up-to-date information was over the Internet, but without electricity or phones in the farmers’ village, access to the Internet seemed impossible.

Lee Thorn, a founder of Jhai Foundation, has worked for the last 7 years in the Hin Heup district of Laos. Jhai has helped to build schools, install wells, and organize a weaving cooperative. During the Vietnam War, Lee was a Navy bomb loader on an aircraft carrier that launched massive air strikes against Laos and Cambodia. Afterward, he was a leading antiwar activist in Berkeley in the 1960s. Lee Felsenstein, who co-founded Jhai, along with Lee Thorn, is well known in Silicon Valley as one of the founders of the Homebrew Club – where Steve Wozniak put together the computer that became Apple, and where Steve Wozniak met Steve Jobs.

The solution Felsenstein and Thorn came up with, to provide Internet access where there is no electricity and no phones, is the Jhai PC. A villager climbs onto a stationary bicycle hooked into a handmade wireless computer and pedals his way to economic self-determinism. It’s the first time a human-powered computer has linked a third world village to the Internet by wireless remote. “This will change everyone’s lives,” says Vorasone Dengkayaphichith,

---

<sup>1</sup> [www.lemelson.org/news/spotlight\\_detail.php?id=612](http://www.lemelson.org/news/spotlight_detail.php?id=612); [www.lemelson.org/news/current\\_detail.php?id=595](http://www.lemelson.org/news/current_detail.php?id=595).

<sup>2</sup> [www.approtec.org/](http://www.approtec.org/); [www.approtec.org/impacts.shtml](http://www.approtec.org/impacts.shtml); [www.approtec.org/jamali.shtml](http://www.approtec.org/jamali.shtml).

<sup>3</sup> [www.jhai.org/](http://www.jhai.org/); cf. [web.idrc.ca/es/ev-41815-201-1-DO\\_TOPIC.html](http://web.idrc.ca/es/ev-41815-201-1-DO_TOPIC.html)

who helps coordinate the project.<sup>1</sup> The residents of these small villages live in bamboo houses with thatch roofs, without electricity and phones. Often, if you want to go to the next village, a few miles away, you walk a dirt road that washes out whenever the rains come.

The bike-pedaled generator powers a battery that in turn runs the computer, which sits in an 8 × 10-inch box and has the power of a 486 chip. It was designed to run on only 12 watts of power, compared to the 90 watts that a typical computer needs. It has no moving parts, the lid seals tight, and you can dunk it in water and it will run. The idea is that it must be rugged, so it will last at least 10 years and will run in both the monsoon and dry seasons.

The computer connects with a wireless card to an antenna bolted on the roof of the bamboo house, and the signal is beamed from there to an antenna nailed to a tree on the top of a mountain, which in turn relays to an Internet service provider in a larger village, 25 miles away. This enables the farmers to get fair pricing for their crops and determine when is best to make the 30-kilometer walk to the market, and it also enables the villagers to use Internet telephony to talk with relatives who live in the capital or overseas.

The work of the Jhai Foundation continues, in building schools and wells, and in working toward everyday use of the Jhai PC, which is in prototype form, in the remote villages. Thirty countries from around the world have expressed interest by contacting Jhai, such as Peru, Chile, and South Africa.

#### *Foundations: Bill and Melinda Gates Foundation*

One of the most visible and dynamic organizations in the United States today is the Bill and Melinda Gates Foundation, located in Seattle, Washington. Founded in 1990, it is led by Bill Gates's father, William H. Gates Sr., and Patty Stonesifer. The foundation has an endowment of approximately \$27 billion. One of its primary focuses is on global health, with a goal of reducing the millions of preventable deaths each year in developing countries:

[W]e have the tools and the knowledge to help close the health gap between rich and poor countries. Condoms to prevent HIV cost about 3 cents each, a dose of measles vaccine costs 25 cents, oral rehydration therapy can save a child's life from diarrhea for just 33 cents, and a bed net to prevent malaria costs \$3.

To improve global health, these proven health solutions should be accessible to all those in need. At the same time, the world must

---

<sup>1</sup> [www.jhai.org/jhai\\_remote\\_launch\\_follow.htm](http://www.jhai.org/jhai_remote_launch_follow.htm).

also accelerate research into new tools to fight disease of the developing world. Of the billions of dollars spent on medical research each year, only 10 percent is devoted to the diseases that cause 90 percent of the world's illness and death.<sup>1</sup>

The foundation works to ensure that lifesaving advances in health are created and shared with those who need them most. To date, it has committed more than \$3.6 billion in global health grants to organizations worldwide; for example, providing financial guarantees to companies developing malaria vaccines. The foundation's three-pronged strategy could be a model for converging technologies more generally:

- Discover: Support discoveries and inventions essential to solving major global health problems
- Develop: Support development and testing of specific tools and technologies
- Adopt: Help ensure that new health interventions and technologies are adopted in the developing world

*Foundations: Kamran Elahian – Schools Online*

Kamran Elahian strives to connect the students of the world through online schools, one computer at a time. Elahian grew up in Iran and moved to the United States at the age of 18. After earning a BS in computer science and a BS in mathematics, he began working with start-up companies. He founded or co-founded 10 high-tech companies, including Cirrus Logic, NeoMagic, PlanetWeb, and Centillion. He has also founded one venture capital firm – Global Catalyst Partners and two non-profit organizations – Schools Online and the Global Catalyst Foundation.

As stated on his Web site, “Inspired by the radical revolutionary, Che Guevara, and the indomitable, peace-loving Mahatma Gandhi, Elahian has developed his own brand of philanthropy – one that makes the most of modern technological innovations, such as the Internet, to bridge social and political differences among people.” He says, “Think of what a modern-day Robin Hood would do. Today, we don't have to snatch wealth from the rich and give it to the poor. We have the means to level the playing field – provide everybody with the best tools to learn and grow, and create new opportunities for economic and social progress and equality.”<sup>2</sup>

---

<sup>1</sup> [www.gatesfoundation.org/GlobalHealth/RelatedInfo/GlobalHealthFactSheet-021201.htm](http://www.gatesfoundation.org/GlobalHealth/RelatedInfo/GlobalHealthFactSheet-021201.htm).

<sup>2</sup> [www.kamranelahian.com/phil.php](http://www.kamranelahian.com/phil.php).

Kamran decided he wanted to make technology available to students whose schools could not afford it. Originally the foundation gave Internet set-top boxes to hundreds of classrooms in the United States. Once the equipment was in the schools, it was found that teachers needed some training on how to make best use of the equipment. In 1999, the foundation switched over to using computers instead of set-top boxes and changed the focus of their program's efforts to developing countries. The Web site of Schools Online reports considerable success: "Since early 2000, there are over 400 schools in 35 countries, besides the U.S., that have received equipment and support necessary to get online. As we continue to learn the most cost effective ways to provide equipment and Internet access, our numbers will continue to grow to include as many schools as possible in developing countries."<sup>1</sup>

*Corporations: Hewlett-Packard and Its E-Inclusion Program*

Some large corporations, like Hewlett Packard, are also changing the world (Gunther, 2003). Barbara Waugh is a lifelong social activist who joined HP in 1984. She has lost none of her youthful idealism at the age of 58 years: "After working to change the world through politics, education, government, and the churches, I believe I can have more impact through the corporate sector." Companies can expand their markets and invent new products by doing business at the "base of the pyramid" where the world's poor are desperate to join the market economy. This philosophy led to the development of the E-Inclusion Division.

One result is that HP has begun a 3-year project designed to create jobs, improve education, and provide better access to government services in the Indian state of Andhra Pradesh.<sup>2</sup> Working with the local government, as well as a branch of HP Labs – which is based in India – the company is studying how to provide the rural poor with access to government records, schools, health information, and crop prices. The hope is to stimulate small tech-based businesses. This builds good will and the HP brand in India and will also help the company discover new, profitable lines of business. Similar efforts are underway in poor cities and rural areas of the United States and South Africa.

Leadership at the top of corporations moves them quickly. A 2003 speech by Chairman and Chief Executive Officer, Carly Fiorina, communicated the approach HP is taking in the work it is doing today:

For too many years, it was easy to assume that because people didn't have opportunity, they didn't have talent. . . . About three years ago, I announced that HP was changing the way it did philanthropy . . .

---

<sup>1</sup> [www.schoolsonline.org/whowere/history.htm](http://www.schoolsonline.org/whowere/history.htm).

<sup>2</sup> [www.hpl.hp.com/india/press/news\\_items/rel\\_feb2502\\_blore\\_sym.pdf](http://www.hpl.hp.com/india/press/news_items/rel_feb2502_blore_sym.pdf).

that we would be committing teams of our best and brightest employees on the ground in different communities for a period of up to three years to work with local citizens. . . . What is the journey? To help use our talent, our resources, our passion to create positive change and to close the opportunity gap. And what are the connections? The connections are to form partnerships between governments, between NGOs, between corporations and communities – to learn from each other, and leverage our collective resources, and power, and possibilities – to change lives and to change futures; in other words, to be both the sailboat and the wind.<sup>1</sup>

C. K. Prahalad, a globally respected business consultant and professor at the University of Michigan’s business school, argues that investment in the developing world can be very profitable while serving the needs of the world’s poorest people. In a powerful new book titled *The Fortune at the Bottom of the Pyramid: Eradicating Poverty through Profits* (Prahalad, 2005), he explains how the “bottom of the pyramid” market works and describes the global opportunities opening up, using detailed case studies from India, Peru, Mexico, Brazil, and Venezuela, covering business that range from salt to soap, banking to cellphones, and health to housing. Testimonials to the book have come from innovation leader Bill Gates, who calls it “an intriguing blueprint for how to fight poverty with profitability,” and former Secretary of State Madeleine K. Albright, who praises it for offering “fresh thinking about emerging markets.”<sup>2</sup>

### **Longer-Term Future**

As we look 5 to 10 years into the future, nano-bio-info-cogno technologies will enable dramatic changes to improve the lives of people in developing countries. Priorities for improvement will center around the key areas of concern to people in those countries – food, shelter, energy, and access to accurate information. Increased life expectancy should come as a result of increased access to water, food, and medicines. There are three key factors in building the infrastructure to support progress:

- Higher levels of education
- Lower birth rates
- Higher percentages of employed women.

---

<sup>1</sup> [www.hp.com/hpinfo/execteam/speeches/fiorina/coro03.html](http://www.hp.com/hpinfo/execteam/speeches/fiorina/coro03.html).

<sup>2</sup> [www.whartonsp.com/title/0131467506](http://www.whartonsp.com/title/0131467506).



Infotech will play a central role, so the wiring of the third world for phones is going to be a powerful phenomenon. As wireless becomes more pervasive, as equipment costs continue to go down, new business models will emerge to provide telephone access to billions of people in developing countries who are not connected today. We can validly talk about the birth of a Global Brain as knowledge becomes an “always-on” commodity. Through the use of Google, with national and global databases, new ways to utilize information in the developing world will emerge. Jhai is one example of this. Voxiva is another. Also notable is the Center for Information Technology Research in the Interest of Society (CITRIS) at the University of California, Berkeley.<sup>1</sup>

One area in which microtech and nanotech will be of critical importance is water purification. Dean Kamen, President of DEKA Research and Development, and inventor of the Segway, is developing a portable water purifier powered by a Sterling engine that can run on such varied fuels as natural gas, kerosene, wood, and even cow manure. He explains, “In many developing nations, centralized water and power plants are as impractical and unaffordable as landline phone networks. *Some 80 percent of all human diseases are carried by waterborne pathogens.* The result is that women in some countries spend four hours per day transporting water, only to bury their children who die from drinking it. Reliable potable water can eliminate that. Imagine that suddenly the developing world had access to safe water and an extra four hours per day to study or work” (Kamen, 2003). Kamen notes that we may need a new state of mind to help the developing world incorporate new technologies effectively.

Biotech in developing countries need not be limited to traditional agriculture but may involve cutting-edge innovations. For example, Cuba had no access to the biotech medicines and lacked the cash it took to buy them, so it evolved its own pharmaceutical industry at the end of the Cold War. Today the country is the largest medicine exporter to Latin America and sells to over 50 different countries. We can well imagine that developing nations might take the lead in cultivating animal stem cells for protein-rich foods, instead of growing animals for food.

Some developing countries – such as Angola, Cambodia, and Afghanistan – face the daunting problem of dealing with the technological residue of human conflicts. Aresa Biodetection, a Danish biotech company, has developed a genetically modified flower that could detect land mines, and scientists are hopeful to have it ready for use within a few years. The genetically modified Thale Cress weed has been coded to change color when the roots come in contact with nitrogen dioxide that is evaporating from explosives buried in the soil. Within 3–6 weeks from being sown over land

---

<sup>1</sup> [www.citris.berkeley.edu/](http://www.citris.berkeley.edu/).

mine-infested areas, the small plant will turn a warning red whenever it grows close to a mine. The problem of how to sow the seeds could be solved by clearing strips in a field, using conventional methods, or by using crop planes.

This research, done at the Institute of Molecular Biology at Copenhagen University, uses the plant's normal reaction to turn red when subjected to stressful conditions such as cold or drought, but has genetically coded it to react only to nitrogen dioxide. The modified weed is infertile and unable to spread its seeds, meaning the risk was minimal that the plant would spread into unwanted areas. Aresa is also interested in using Thale Cress to detect and clean soil contaminated by heavy metals such as lead, copper, zinc, and chromium – a major source of pollution in industrialized countries.<sup>1</sup>

Some health-related biotech innovations may serve people in both developed and developing countries but be especially valuable for the latter because until now they have lacked adequate health and dental care. In England, scientists are working on the ability to use stem cells to grow replacement teeth that have become lost or damaged. Stem cells are taken from a patient, treated and cultured in a laboratory, then reimplanted in the patient's jaw under the gum at the site of the missing or extracted tooth. This then will grow into a fully formed, live tooth. "A key medical advantage of our technology is that a living tooth can preserve the health of the surrounding tissues much better than artificial prosthesis," says Paul Sharpe of the Dental Institute, Kings College, London.<sup>2</sup>

Accurate and affordable disease diagnoses would be especially useful in developing countries, where medical resources must be used most efficiently. There is a real possibility that microfluidic chips – perhaps relying upon nanotechnology—could enable diagnostics for less than a dollar. High-tech gadgets using a single drop of blood are going to be able to determine a person's risk for all known genetic diseases. Professor Samuel Sia of Harvard says, "How can we take advantage of microfluidic advances if you are in the middle of a West African village?" Using microfluidic chips, we may be able to get the cost of this test down radically. Sia says, "A diagnostic test has to cost a dollar or less to make any inroads in the developing world" (Goho, 2004).

Sia, in collaboration with George Whitesides, has invented an automated, miniaturized ELISA (enzyme-linked immunosorbent assays) test (Sia and Whitesides, 2003). Their new device uses a coin-sized plastic chip loaded with whisker-sized channels. Each of the chips can mix tiny volumes of fluid, mimicking the components of a chemistry lab. The Harvard researchers attach to the bottom channel a stripe of protein fragments of HIV. When a miniscule blood sample spreads through the channels, it can identify the

---

<sup>1</sup> [www.aresa.dk/landmines.htm](http://www.aresa.dk/landmines.htm); see also Reuters Limited, January 27, 2004.

<sup>2</sup> [www.nesta.org.uk/mediaroom/newsreleases/4278/index.html](http://www.nesta.org.uk/mediaroom/newsreleases/4278/index.html).

presence and concentration level of anti-HIV antibodies and display this information on the screen of an optical reader.

The whole process takes 20 minutes, instead of the normal 5–6 hours. To keep costs down, researchers looked for lower-cost parts for the sensor – scavenging a laser from a DVD player and a light detector from a copy machine. They combined those pieces with a small liquid crystal display and a nine-volt battery to create a palm-sized device that costs about \$45. With this reusable detector, the per test cost would be under a dollar – the cost of the microfluidic chip.

Cognotech – new technology based on cognitive science – holds much promise to enhance human performance in the future. Already we see new concepts, such as smart mobs, unusual groups of individuals who get together in person, via cell phones, or via e-mail and form groups to accomplish specific objectives, with profound swarm intelligence. Cognotech will help us unleash the power of play. For example, Howard Gardner’s (1993) “Multiple Intelligences” theory suggests that there is not just one kind of intelligence, but as many as seven, and people may be intelligent in many different ways. The “Motivated Skills” approach of Bernard Haldane (1996) helps people identify what they do well and enjoy doing.

## **Conclusion**

Alvin Toffler has said that “We are entering an era where we are a molecular civilization.” As Larry Bock, founder of Nanosys and 12 other companies (10 of which successfully went public) says, “I feel my way through technology.”

Those who are feeling their way through the dawn of molecular science today are finding themselves in very unusual circumstances. The laws of quantum physics often apply at the nano level, and classical Newtonian laws of physics do not hold. We are no longer objects, human bodies, living in a world full of valuable objects. We are flows of energy, vectors, interacting in a world in which successful chemistries make things happen – either very quickly or very ineffectively. Its either  $2 + 2 = 8$  or  $2 + 2 = 1$ . Just look at the loss of market capitalization of major corporate mergers.

In this time, after the Internet and the telecom bubbles have burst, it is easy to be cynical and assume that change is over-hyped. This is precisely the time to throw out, on a monthly basis, your preconceived notions and see what emerging things are growing exponentially around you. Everyone knows the sleeping giant of China is waking up and will dramatically shape the global economy. Developing countries, such as Vietnam, India, and Israel, are also waking up to a global race, where the power of entirely new chemistries – entirely new economic ecosystems – will determine the winners.

Those who are slow to act decisively are simply antiques bound for obsolescence. Tom Peters, author of *In Search of Excellence* and other books on embracing business change, says “It’s not Ready, Aim, Fire – it’s Ready, Fire, Aim” (Peters, 1994; Peters and Waterman, 1997)!

We are all outside on a clear, pitch-dark, warm night – feeling our way through these challenges. The winners will not be known for two to ten years, so do not wait for external validation. It is now all about dynamic chemistries as we enter the era of the global village. Adaptability is key. The United States could be a bit player in a post-molecular future. Organizations like Voxiva, the World Bank, the Gates Foundation, and Jhai are leading the way, and they will be passed by organizations we do not even know about today.

Technology is becoming invisible – you only gauge it by its results. Expect it to be messy. Expect it to be hard to quantify. Get creative and get busy, and work across cultural boundaries powerfully. Ready, Fire, Aim!

It takes the heroic efforts of passionate people, like Paul Meyer, Kamran Elahian, Lee Thorn, and Bill Gates – and many, many others who are fighting this good fight, who toil without recognition – so people can live human lives, with a bit of hope, with a little less desperate suffering.

Let us work together, using the power of converging technologies to: a) move forward, b) keep our humanity alive, and c) help the world to live and grow and adapt. This goal can only be realized by a dedicated individual who is able to focus on one passion and one accomplishment at a time.

## References

- Annan, K. 2002. Kofi Annan’s IT challenge to Silicon Valley. November 5, online, [news.com.com/Kofi+Annans+IT+challenge+to+Silicon+Valley/2010-1069\\_3-964507.html](http://news.com.com/Kofi+Annans+IT+challenge+to+Silicon+Valley/2010-1069_3-964507.html).
- Fisher, A. 2000. Peace-over-IP, *Wired Magazine* 8(4). [www.wired.com/wired/archive/8.04/mustread.html?pg=10](http://www.wired.com/wired/archive/8.04/mustread.html?pg=10)
- Gardner, H. 1993. *Multiple Intelligences: The Theory in Practice*. New York: Basic Books.
- General Assembly. 2000. *United Nations Millennium Declaration*. New York: United Nations. [www.un.org/millennium/declaration/ares552e.pdf](http://www.un.org/millennium/declaration/ares552e.pdf).
- Goho, A. 2004. Diagnosing the developing world. *Science News* 165 (7, February 14): 108.
- Gunther, M. 2003. Tree huggers, soy lovers, and profits. *Fortune* 147 (13, June 23).
- Haldane, B. 1996. *Career Satisfaction and Success: A Guide to Job and Personal Freedom*. Indianapolis, Ind.: JIST Works.
- Kamen, D. 2003. Tech where it’s needed. *Business 2.0*, online July 1, 2003; [www.business2.com](http://www.business2.com).
- Peters, T. J. 1994. *The Pursuit of Wow!: Every Person’s Guide to Topsy-Turvy Times*. New York: Vintage.
- Peters, T. J., and R. H. Waterman, Jr. 1997. *In Search of Excellence: Lessons from America’s Best-Run Companies*. Thorndike, Maine: G. K. Hall.

- Prahalad, C. K. 2005. *The Fortune at the Bottom of the Pyramid: Eradicating Poverty through Profits*. Upper Saddle River, N.J.: Wharton School Publishing.
- Reingold, J. 2001. Fast foundation, *Fast Company* 43(February): 124.
- Riordan, T. 2004. Expanding the reach of patent prizes. *New York Times*, April 26.
- Schumacher, E. F. 1973. *Small Is Beautiful: A study of Economics as if People Mattered*. London: Blond and Briggs.
- Schwab Foundation. 2003. *Outstanding Social Entrepreneurs 2003*. Geneva, Switzerland: Schwab Foundation for Social Entrepreneurship.
- Sia, S. K., and G. M. Whitesides. 2003. Microfluidic devices fabricated in poly(dimethylsiloxane) for biological studies. *Electrophoresis* 24: 3563–3576.
- United Nations Development Group. 2003. *Indicators for Monitoring the Millennium Development Goals*. New York: United Nations. [www.eclac.cl/mdg/docs/indicadores/Metadatajn30.pdf](http://www.eclac.cl/mdg/docs/indicadores/Metadatajn30.pdf).

## 9. NANOTECHNOLOGY FOR BIOLOGY AND MEDICINE

*James R. Baker, Jr., University of Michigan*

*Abstract:* This chapter reviews many of the ways that nanotechnology may impact human health. Nanotechnology may provide new diagnostic and therapeutic techniques for intervention with environmental disorders, developmental diseases, and degenerative diseases. The chapter considers the opportunities likely to arise over short-term, mid-term, and long-term time scales. It also recognizes the technical challenges of using nanomaterials for biology and medicine and their possible adverse consequences. It concludes with a brief description of the Center for Biological Nanotechnology, which is pioneering in this area, and offers a vision of the future.

### **Introduction**

Many of the crucial problems in biology and medicine are not handled by current science or therapies. It was once hoped that understanding the molecular pathways underlying biological systems would provide a means for therapeutic interventions for most human diseases; however, in many cases this has not happened. A good example of the disconnect between molecular understanding and therapy is cystic fibrosis, for which a full understanding of the function and pathophysiology of the disease is now clear; however, no new cystic fibrosis therapy has emerged from this knowledge (Gill *et al.*, 2004). Therefore, new approaches must be undertaken to investigate biological systems as nanoscale structures to learn structure/function relationships that will allow mechanical corrections of physiological defects. Other endeavors into designing human therapeutics, imaging agents, and diagnostic materials at nanoscale dimensions will also be important in solving fundamental problems in biology and medicine.

### **The Hope of Nanotechnologies for Biology and Medicine**

I will focus this review on areas of nanotechnology that impact human health, because they have great interest to all individuals and provide good examples of how nanotechnology may impact all biological systems. This review is obviously not meant to be exclusive, as the issues presented here have implications for all of biological science. One might look at this discussion as “lessons learned” that can be applied to other topics. However, even when limiting our discussions to global issues in human health, there are three broad areas in which nanotechnology could play an important role: environmental disorders, developmental diseases, and degenerative diseases.

Intervention into each of these areas offers tremendous potential benefits; however, each one may benefit different portions of the world's population.

Environmental disorders are an important cause of human disease and toxicity throughout the world. Intervention in this group of disorders has the potential to provide the most global benefit from nanotechnology. This is because these problems are of paramount importance in underdeveloped regions of the world (Singer and Daar, 2001). Environmental disorders include a broad range of environmentally caused illnesses brought on by such diverse factors as infection, chemical toxicity, behavioral problems related to addiction or illicit substance use, and exposure to radiation through either natural or manmade sources. Although many of these disorders are better managed in the industrialized world, new types of infections, releases of chemicals into the environment, and the development of new radiation sources are unique problems for developed countries that also could be addressed by nanotechnology (Koifman and Koifman, 2003). Issues related to global conflict and bioterrorism also might be addressed by nanotechnology (Fritz *et al.*, 2002).

Developmental diseases such as congenital illnesses and developmental problems not related to genetics are a second area that may be ameliorated by nanotechnology. Interventions that improve these disorders offer the greatest benefit to the individual, because one could prevent a lifetime of suffering (Banks, 2003). Although most of these disorders are the result of genetic causes, which could be addressed by new nanomedicines, problems with nutrition and environmental deficiencies that harm human development are also major issues (Nomura, 2003). These approaches would include the ability of nanomaterials to analyze and enhance the food supply, as well as attempts to prevent the exposure of developing humans to environmental toxins.

Finally, degenerative diseases are an area in which nanotechnology may improve human health. Interventions in this area may achieve the greatest overall benefit in developed and industrial societies because of the tremendous financial implications for these societies of caring for large elderly populations with degenerative diseases (Hammel, 2003). Problems involved in degenerative diseases include both normal and abnormal aging, trauma, and the results of chronic inflammation and autoimmune diseases. Although most current approaches to treating these diseases involve limiting their impact through attempts to suppress disease severity and replace function, something that would prevent or cure these diseases and result in complete restoration of function would be a remarkable accomplishment that would save society countless billions of dollars (McCormack, 1998).

### **How Can Nanotechnology Innovate?**

One can identify and prioritize the various nanotechnology approaches to the intervention of human disease:

- Detection and diagnosis of disease
- Prevention of disease
- Improved therapy for disease
- Restoration of function after disease or trauma.

To clarify the significance of this list, the specific areas form a continuum from identifying and treating illnesses to finally attempting to remedy the effects of disease. This continuum spans the entire course of human health. Approaches to health intervention begin with diagnostic tests that detect either the presence of the disorder or susceptibility to this disorder. This is a near-term goal of nanotechnology because many of these diagnostics can be performed outside of the body and therefore are not limited by the problems of biologic systems and biocompatibility. This approach will allow the prevention of illnesses, which may be most effective in terms of limiting the impact of a disease. Subsequent to this would be the treatment of disease, using new types of medications that have benefits that exceed current therapies. This would include targeted therapeutics that have greater benefit and fewer side effects, in part because of individualized approaches based on a patient's genetic susceptibility (Phillips *et al.*, 2003).

The longer-term goals in health and medical innovation would be beyond our current concepts of medical treatment. These would involve things like regeneration of function (Evans, 2000), allowing not just the removal or the modification of the disease process but, in fact, the regeneration of normal tissue and normal function in a way that truly gives the individual improved finite function. In addition, one would hope that eventually nanomedications would lead to enhancement of function of human biologic systems, not only involving regenerating function but also improving it to prevent disease (Lehmann-Horn and Jurkat-Rott, 2003). This might include such concepts as increased intelligence and neural function, improved energy utilization by cells, better immunity to prevent infections, or modification of genetic abnormalities to prevent subsequent disease. Although these last concepts may seem to be far-reaching and far off before they can be achieved, there is hope that within a 25-year timeframe, many of them could become reality.

### **Areas of Nanotechnology Impact**

Two areas in which nanotechnology approaches will impact human health are in the development of new diagnostic and therapeutic agents. Whereas



most people understand the promise of new therapies for treating diseases, an improved ability to diagnose the predisposition for or presence of a disease before damage has occurred would be invaluable. Specific examples of nanotechnology innovations in these two areas follow.

### *Diagnostic Applications*

Nanotechnology improvements in diagnostics can be subdivided by the time to their impact, from short-term to long-term. Improvements in diagnostics over the short term would essentially involve improvements in current laboratory techniques that would allow measurement with greater sensitivity and specificities (Majumdar, 2002). Nanotechnology-based assays may also allow the identification of unique biologic molecules not addressable by current assays. This could lower the costs of laboratory tests and make them available to greater numbers of individuals worldwide.

Mid-term advances in diagnostics will involve diagnostics that are integrated into biologic systems. This would include concepts such as sensors within humans' cells and bodies that would provide constant information on biologic function (Shim *et al.*, 2003). These sensors would allow the real-time monitoring and management of humans in any environment through wireless networks and in the same way that mechanical systems such as automobiles or airplanes are maintained. Constant feedback from biologic data would permit the immediate correction of abnormalities in an individual. This "early warning"-type approach could prevent disease before it starts and would be much more effective than the current technologies. Examples would be real-time control of insulin pumps in response to glucose monitoring, or warning alerts to reduce stress loads on joints to prevent orthopedic injuries (i.e., vehicle stability controls for people). This also might allow the monitoring of brain function to help in managing problems like addiction.

Long-term concepts in diagnostics would build on a biologically integrated diagnostic approach and would directly couple sensor systems to treatment modalities (Anderson *et al.*, 2000). One could envision a system that would monitor cellular function and, when abnormalities occur, would release therapeutics that could restore normal function. In addition, cell sensors could monitor for genetic changes that are the earliest events associated with cancer development and fix genetic abnormalities before they could cause tumors. These would be truly unique applications and, most important, could be seamlessly integrated into an individual once disease susceptibility was identified. They would also lower the societal cost of illness because by preventing some kinds of illness and disability entirely.

### *Therapeutic Applications*

Improvements in therapeutics for humans achieved by nanotechnology also can be subdivided by the time lag before their introduction. “Smart therapeutics” can be expected within the next decade for the specific delivery of drugs and genetic agents. This will provide a degree of specificity in the action of therapeutics that could prevent side-effects and improve efficacy (Patri *et al.*, 2003). Examples of this include drugs that specifically kill cancer cells and that can be given daily to control tumor growth without the nausea or hair loss of chemotherapy. Additional drugs could be developed that would produce individualized therapy for genetic disorders by turning off a single abnormal gene. These approaches would improve current therapeutics and would be readily applicable to a broad range of disorders.

Mid-term therapeutic developments would most likely involve combination therapeutics. These therapeutics would allow drug delivery systems to also include diagnostic imaging and interventional components. A physician would be able to identify a predisposition to a disease, image to determine whether the disease has caused any disability, and then intervene with specific therapeutics (Harisinghani *et al.*, 2004). Examples of this could be the early detection and prevention of cancer, the identification and treatment of the earliest events of infectious disease, and the identification and prevention of genetic disorders. These approaches might also allow for the enhancement of current therapeutics by combining therapeutics in one agent or allowing other systems, such as implants, to function more efficiently.

Long-term therapeutic developments would include nanosystems that totally replace, repair, and regenerate diseased tissue. This could involve the correction of developmental defects or the resolution of problems from disease and trauma. Examples include rebuilding a heart that had developed abnormally because of viral infection or genetic disorder; killing a tumor with the subsequent replacement of the underlying tissue in its normal pattern while also correcting the genetic defects that predispose an individual’s tissue to become cancerous. This type of therapeutic could also resolve the results of trauma, such as healing a skull fracture and brain damage that occurred after a drunk-driving accident, while also correcting the underlying brain disorder that predisposed the individual to alcohol addiction.

### **Nanomaterials for Biology and Medicine**

Specific examples provide insights into the potential of nanomaterials in diagnostics and therapeutics. Designing materials at the nanoscale that function as “spare parts” in biologic systems allows potential opportunities that are not addressable with current approaches. Whereas drugs like Gleevec

achieve targeting of a specific physiological pathway by functional inhibition of a unique oncogene product in a cancer cell (Smith *et al.*, 2004), most tumors or other biologic systems have a complexity of molecular alterations that cannot be approached by a single “magic bullet.” The ability to create therapeutic structures, channels, or diagnostic agents small enough to escape blood vessels and insert into specific types of cells, such as cancer cells, requires materials less than 20 nanometers in diameter (Kong *et al.*, 2000). By targeting these agents through receptors, even if they are not entirely specific for a tumor, we have been able to direct a carried drug or other type of therapeutic into tumor cells to achieve a therapeutic index that is orders of magnitude better than current non-targeted chemotherapy. Figure 1 shows a model of a drug-delivery nanodevice that has improved efficacy and decreased toxicity of chemotherapeutic agents in cancer treatment.

**Figure 1. Model of a Drug-Delivery Nanodevice**

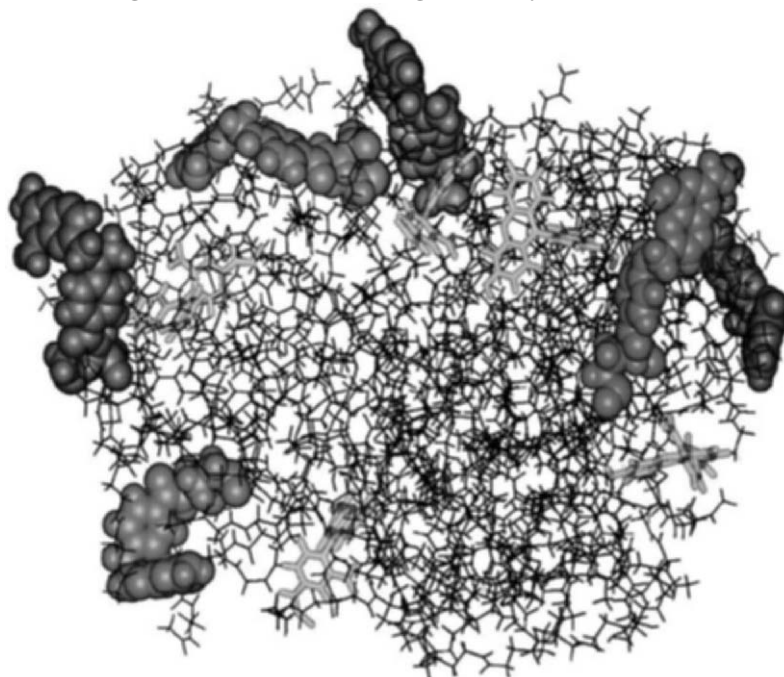

Another type of nanomedicine therapeutic would be an actual therapeutic nanostructure. Cystic fibrosis is again a good example, where instead of trying to correct a defective gene (Gill *et al.*, 2004), one could create a nanostructured ion channel that could be inhaled and self-assemble into the membranes of respiratory epithelial cells to correct chloride transport. However, to do this, one needs to understand the function of the natural ion channel, the design of the materials, and the potential toxicology of the

synthetic nanostructure to make sure that it would actually be a useful approach *in vivo*. Therefore, entire new types of therapeutic approaches could be envisioned with nanomaterials.

The sensing and monitoring of systems function could also be revolutionized by nanomaterials. Making sensors that could fit inside cells and monitored non-invasively would allow the continual evaluation of events in biological systems or humans. This could potentially allow people to be imaged and monitored in their home to a greater degree of accuracy than what is currently available in hospitals; it could also enable individuals to live independently regardless of their disability or health problem. Sensing could also be used to measure small alterations in human function that are related to toxic elements in the environment or other types of abnormalities or degenerative diseases. Examples of this concept involve using fiber-optic probes to analyze evolving tumors, as well as a project that we are working on for NASA, in which Fluorescence Resonance Energy Transfer (FRET) sensors are placed into lymphocytes to monitor apoptosis as a measure of radiation exposure (Myaing *et al.*, 2003; Thomas *et al.*, 2004). The fluorescent signals are continually captured from retinal or tympanic membrane capillaries through a low-power, two-photon laser system. This allows very early and accurate determinations of increased radiation exposure, in part because of very extensive baseline readings that overcome the physiology variations caused by circadian fluctuations or other daily activity. Figure 2 shows how a radiation monitoring system for astronauts could be based on nanotechnology sensors placed in cells.

The ability to analyze biologic systems or bio-inspired systems on a nanometer scale would also be aided by nanostructured materials. We have already been able to monitor neuronal cells and have been able to demonstrate actual physical changes in shape of 10–20 nanometers associated with electrical activation, as illustrated in Figure 3. This allows an understanding into how these cells function but can only be accomplished by using systems that were developed for nanoscale analysis, in this case an Atomic Force Microscope (AFM), in conjunction with specially designed biological containers (Shenai *et al.*, 2004). Figure 3 shows neurons on a circuit board in an AFM (left) and AFM image of the cell (right). The white bar on the left is 20  $\mu\text{m}$ , and the one on the right is 2  $\mu\text{m}$ .

Bio-inspired designs also would allow a better understanding of biologic systems through using them as models. We have performed molecular modeling of synthetic systems to understand receptor function and have used specially synthesized polymeric receptors to study viral adhesion and internalization into cells (Reuter *et al.*, 1999; Landers *et al.*, 2002). Therefore, in a number of broad and significant areas, synthetic nanomaterials may be crucial to the future success of science and medicine.

**Figure 2. A Nano-Enabled Radiation Monitoring System**

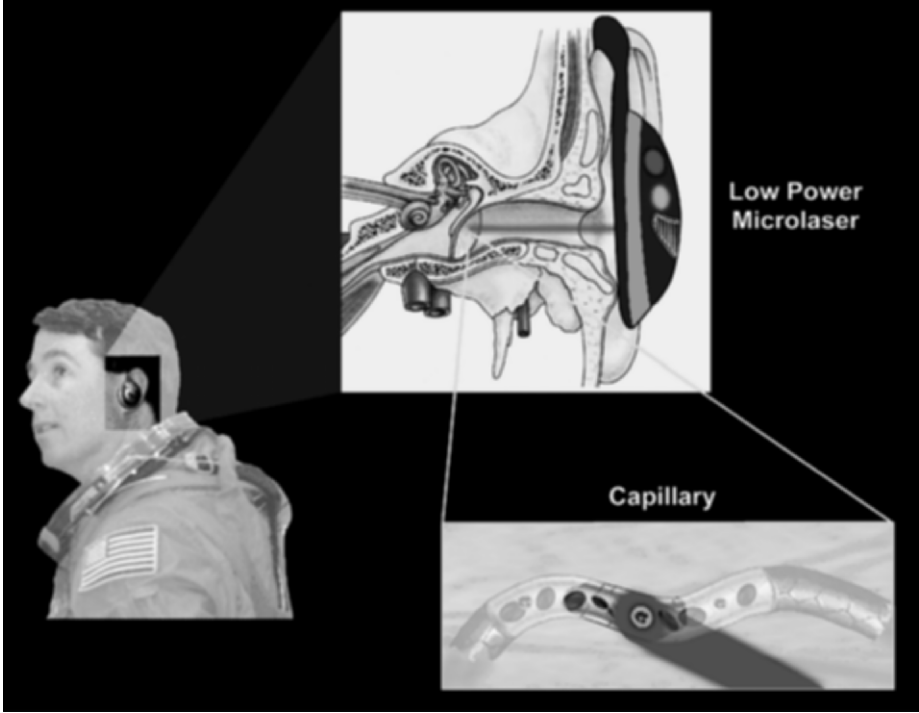

**Figure 3. Neurons on a Circuit Board**

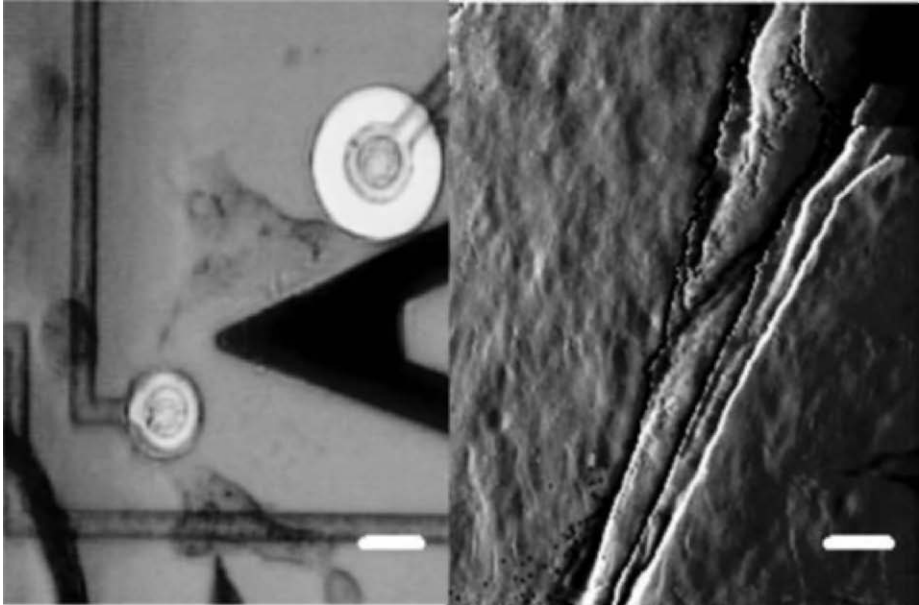

### **Adverse Consequences of Nanomaterials**

There are already movements around the world proposing the banning of nanomaterials, and certainly there are concerns about these materials. Bio-inspired materials may create difficulties for biologic systems and ecosystems, as their small size allows them to be easily internalized in organisms. These materials can mimic biologic molecules and disrupt their function, and there have also been problems with certain synthetic structures such as “buckyballs” and carbon nanotubes, which have been demonstrated to have toxic effects on cells and animals (Oberdorster, 2004). Some of these problems arose from an incomplete appreciation of the complexity of biological systems, and therefore a lack of appropriate caution when using nanomaterials. Many excellent chemists and other material scientists have developed nanoscale materials for biological applications that failed because of their toxicity or because they were bioincompatible (West and Halas, 2003; Lam *et al.*, 2004). This again was not because they were poorly conceived but because the complexity of an organism makes it difficult to predict the consequence of a material on biologic systems. To avoid these problems, it is crucial that individuals working in this area have a clear understanding of both synthetic nanomaterials and biological systems. The latter is particularly important because the complexity of biological systems is much greater than that of synthetic materials.

Toxicology is often apparent to some physical scientists only if a nanomaterial immediately kills cells in tissue culture. In contrast, studies by us and others have been able to show that the toxicity of some nanomaterials is very complex and can involve specific interactions between biological and synthetic materials. For example, Figure 4 illustrates how positively charged dendrimers of particular diameters can actually rip lipid bilayers off cells to form micellar-like structures leading to cytotoxicity (Mecke *et al.*, 2004). Thus, a careful examination of the biocompatibility of nanomaterials is necessary as part of any development program.

### **The Center for Biological Nanotechnology**

The development of the Center for Biological Nanotechnology predates the current fashionable focus the field enjoys. It was based on concerns about the use of viral systems for gene transfer because of immune responses to these vectors. In response to these concerns, my colleagues and I made an effort to develop synthetic systems for gene delivery. We performed studies with both lipids and polymers, but it quickly became clear that nanoscale materials were very important in this process. This was because of the need of these vectors to escape the bloodstream through vascular pores

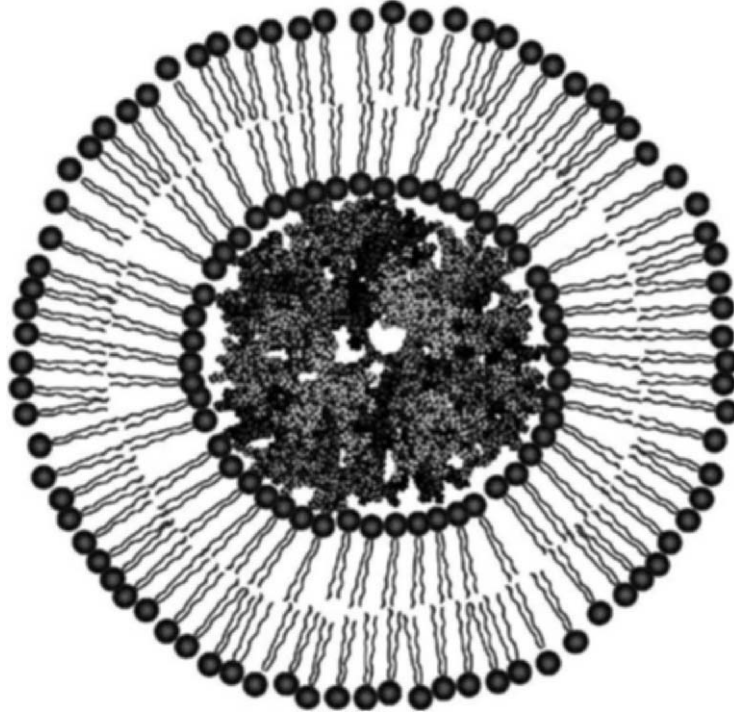
**Figure 4. Dendrimer Wrapped in Lipid Bi-layer from a Cell**

(approximately a 20–50-nanometer diameter limit) and then be internalized into cells effectively (approximately a 150-nanometer diameter limitation in size). Although we were able to develop non-viral gene transfer systems that were efficient enough to gain commercial success *in vitro*, the use of this material *in vivo* did not pan out because of the lack of efficiency and untoward effects found in some biological systems. To improve this work and to expand the application of synthetic materials to other applications, I became convinced that a multidisciplinary approach involving chemists, engineers, and biologists was necessary. To accomplish this, we formed the Center for Biologic Nanotechnology in 1998.<sup>1</sup>

Over the past 6 years, our center has become a leader in a number of areas in nanoscale science for biologic and medical applications. Our studies have involved a number of different nanomaterials and yielded unique applications ranging from non-toxic antimicrobials to targeted cancer therapeutics. The work has involved 60 scientists from areas as diverse as chemistry, optics, bioengineering, applied physics, and bioinformatics. We are most proud that this effort has resulted in three startup companies, some that have materials in advanced clinical trials. Although this area is still in its infancy, several

---

<sup>1</sup> [www.nano.med.umich.edu](http://www.nano.med.umich.edu)

things are becoming clear. There are tremendous opportunities available in applying nanotechnology to biology and medicine, as previously outlined. Unique qualities of molecules like quantum dots may facilitate new applications (Lim, *et al.*, 2003). However, many of the material science concepts developed for interaction with biologic systems are highly flawed. The idea that metal probes that contain materials such as cadmium, selenium, and lead would become “completely” biocompatible merely by covering them with silicate or albumin shows a complete lack of understanding of the toxicology of biologic systems (Derfus *et al.*, 2004). The mechanical “nanobots” that have been proposed for human therapeutics are mainly science fiction, as they would not be compatible with biological systems but would also disobey the laws of physics in their operation (Smalley, 2001). Even many of the tissue engineering efforts in which bio-inspired materials or biomaterials are placed into arrays or on “chips” suffer a lack of understanding of the what is needed to maintain the biologic components (Li *et al.*, 2003). Understanding the biologic components of these systems is not only important for materials that might be used in organisms or humans but also when trying to construct bio-inspired systems for work *in vitro*. Thus, our ongoing focus will be the primary technical limitation to nanomedicine, which is the compatibility of biologic and synthetic materials.

### **The Visionary Future of Nanotechnology for Medicine**

Where might this all lead? The goal would be to prevent human suffering and disability from disease. Nevertheless, how might that be achieved? The early diagnosis of a predisposition for disease could allow intervention before illness and prevent disease. This intervention could be accomplished through “synthetic replacement parts” for dysfunctional biological molecules developed through nanoscale engineering. Although this is an attractive concept, as it will prevent an individual from ever seeing the ravages of disease, it also goes against human nature. Because individuals do not take advantage of the preventative diagnostic and therapeutic agents that are currently available (Urquhart, 2001; Yang *et al.*, 2003), it is possible (likely) that they will not take advantage of improved diagnostics. So, we will be forced to continue to reclaim individuals from damaged and diseased states. Using nanostructured materials to replace damaged tissues or to provide a matrix for cells to implant and recreate organs could overcome paralysis, kidney and liver failure, heart attacks, or even strokes. The potential here is truly remarkable.

If there is a major ethical issue to this vision, it may be how we will define “normal.” If we have the ability to “restore” function, what limits us from “improving” function? Many might consider it appropriate to “improve” liver function to prevent a genetic disease, although most would not think it



appropriate to “improve” muscle function to improve athletic competitiveness. In the same way that growth hormone has created moral issues about short stature (Sandberg and Voss, 2002), will nanomedicine create similar concerns about marginal intelligence, personality disorders, and reproductive potential? Some way must be developed to obtain a societal consensus to guide our science in these areas.

Although the concepts in this review are truly far ranging in scope and timeline, they show the potential for nanomedicine. However, future technology will have to pass economic tests as well as efficacy tests if it is to be adopted. Therapeutics that do not save the health care system money will find it difficult to gain wide acceptance, no matter how useful they may seem. Therapies available only to the wealthy would undermine the social fabric of human society. As with any therapeutic, the first rule of nanomedicine will be “*Primum non nocere*” or first, do no harm. This is true in the case of nanomedicine, whether the harm be medical or financial.

## References

- Anderson, S. A., R. K. Rader, W. F. Westlin, C. Null, D. Jackson, G. M. Lanza, S. A. Wickline, and J. J. Kotyk. 2000. Magnetic resonance contrast enhancement of neovasculature with alpha(v)beta(3)-targeted nanoparticles. *Magnetic Resonance in Medicine* 44: 433–439.
- Banks, M. E. 2003. Disability in the family: A life span perspective. *Cultural Diversity and Ethnic Minority Psychology* 9: 367–384.
- Evans, G. R. 2000. Challenges to nerve regeneration. *Seminars in Surgical Oncology* 19: 312–318.
- Derfus, A. M., W. C. W. Chan, and S. N. Bhatia. 2004. Probing the cytotoxicity of semiconductor quantum dots. *Nano Letters* 4: 11–18.
- Fritz, S. V., A. M. Singer, V. B. Revan, and J. R. Baker, Jr. 2002. Bioterrorism: Relevance to allergy and immunology in clinical practice. *The Journal of Allergy and Clinical Immunology* 109: 214–228.
- Gill, D. R., L. A. Davies, I. A. Pringle, and S. C. Hyde. 2004. The development of gene therapy for diseases of the lung. *Cellular and Molecular Life Sciences* 6: 355–368.
- Hammel, J. 2003. Technology and the environment: Supportive resource or barrier for people with developmental disabilities? *Nursing Clinics of North America* 38: 331–349.
- Harisinghani, M. G., J. Barentsz, P. F. Hahn, W. M. Deserno, S. Tabatabaei, C. H. van de Kaa, J. de la Rosette, and R. Weissleder. 2004. Noninvasive detection of clinically occult lymph-node metastases in prostate cancer. *New England Journal of Medicine* 348: 2491–2499.
- Koifman, S., and R. J. Koifman. 2003. Environment and cancer in Brazil: An overview from a public health perspective. *Mutation Research* 544: 305–311.
- Kong, G., R. D. Braun, and M. W. Dewhirst. 2000. Hyperthermia enables tumor-specific nanoparticle delivery: effect of particle size. *Cancer Research* 60: 4440–4445.

- Lam, C.-W., J. T. James, R. McCluskey, and R. L. Hunter. 2004. Pulmonary toxicity of single-wall carbon nanotubes in mice 7 and 90 days after intratracheal instillation. *Toxicological Sciences* 77: 126–134.
- Landers, J. J., Z. Cao, I. Lee, L. T. Piehler, P. P. Myc, A. Myc, T. Hamouda, and J. R. Baker, Jr. 2002. Prevention of influenza pneumonitis by sialic-acid conjugated dendritic polymers. *Journal of Infectious Diseases* 186: 1222–1230.
- Lehmann-Horn, F., and K. Jurkat-Rott. 2003. Nanotechnology for neuronal ion channels. *Journal of Neurology, Neurosurgery, and Psychiatry* 74: 1466–1475.
- Li, N., A. Tourovskaia, and A. Folch. 2003. Biology on a chip: Microfabrication for studying the behavior of cultured cells. *Critical Reviews in Biomedical Engineering* 3: 423–488.
- Lim, Y. T., S. Kim, A. Nakayama, N. E. Stott, M. G. Bawendi, and J. V. Frangioni. 2003. Selection of quantum dot wavelengths for biomedical assays and imaging. *Molecular Imaging* 2: 50–64.
- Majumdar, A. 2002. Bioassays based on molecular nanomechanics. *Disease Markers* 18: 167–174.
- McCormack, B. 1998. Individual choice. *Elderly Care* 10: 21–23.
- Mecke, A., S. Uppuluri, T. Sassanella, D.-K. Lee, A. Ramamoorthy, J. R. Baker, Jr., B. Orr, and M. Banaszak-Holl. 2004. Direct observation of lipid bilayer disruption by poly(amidoamine) dendrimers. *Chemistry and Physics of Lipids* 132(1): 3–14.
- Myaing, M. T., J. Y. Ye, T. B. Norris, T. Thomas, J. R. Baker, Jr., W. J. Wadsworth, G. Bouwmans, J. C. Knight, and P. S. Russell. 2003. Enhanced two-photon biosensing with double-clad photonic crystal fibers. *Optics Letters* 28: 1224–1226.
- Nomura, T. 2003. Transgenerational carcinogenesis: Induction and transmission of genetic alterations and mechanisms of carcinogenesis. *Mutation Research* 544: 425–432.
- Oberdorster, E. 2004. Manufactured nanomaterials (Fullerines, C<sub>60</sub>) induce oxidative stress in the brain of juvenile largemouth bass. *Environmental Health Perspectives* 112: 1058–1062.
- Patri, A., I. Majoros, and J. R. Baker, Jr. 2003. Dendritic polymer macromolecular carriers for drug delivery; using nanotechnology for drug development and delivery. *Current Opinion in Chemical Biology* 6(4): 466–471.
- Phillips, K. A., D. Veenstra, S. Van Bebber, and J. Sakowski. 2003. An introduction to cost-effectiveness and cost-benefit analysis of pharmacogenomics. *Pharmacogenomics* 4: 231–239.
- Reuter, J. D., A. Myc, M. M. Hayes, Z. Gan, R. Roy, D. Qin, R. Yin, L. T. Piehler, R. Esfand, D. A. Tomalia, and J. R. Baker, Jr. 1999. Inhibition of viral adhesion and infection by sialic-acid conjugated dendritic polymers. *Bioconjugate Chemistry* 10: 271–278.
- Sandberg, D. E., and L. D. Voss. 2002. The psychosocial consequences of short stature: A review of the evidence. *Best Practice and Research Clinical Endocrinology and Metabolism*. 16: 449–63.
- Shenai, M. B., K. G. Putchakayala, J. A. Hessler, B. G. Orr, M. M. Banaszak Holl, and J. R. Baker, Jr. 2004. A novel platform for the measurement of real-time, nanometric morphological alterations of electrically stimulated neuroblastoma cells. *IEEE Transactions on Nanobioscience* 3: 111–117.

- Shim, J., T. F. Bersano-Begey, X. Zhu, A. H. Tkaczyk, J. J. Linderman, and S. Takayama. 2003. Micro- and nanotechnologies for studying cellular function. *Current Topics in Medicinal Chemistry* 3: 687–703.
- Singer, P. A., and A. S. Daar. 2001. Harnessing genomics and biotechnology to improve global health equity. *Science* 294: 87–89.
- Smalley, R. E. 2001. Of chemistry, love and nanobots. *Scientific American* 285(3): 76–77.
- Smith, J. K., N. M. Mamoon, and R. J. Duhe. 2004. Emerging roles of targeted small molecule protein-tyrosine kinase inhibitors in cancer therapy. *Oncology Research* 14(4–5): 175–225.
- Thomas, T. P., M. T. Myaing, J. Y. Ye, K. Candido, A. Kotlyar, J. Beals, P. Cao, B. Keszler, A. K. Patri, T. B. Norris, and J. R. Baker, Jr. 2004. Detection and analysis of tumor fluorescence using a two-photon optical fiber probe. *Biophysical Journal* 86: 3959–3965.
- Urquhart, J. 2001. Some economic consequences of noncompliance. *Current Hypertension Reports* 3: 473–480.
- West, J. L., and N. J. Halas. 2003. Engineered nanomaterials for biophotonics applications: improving sensing, imaging, and therapeutics. *Annual Review of Biomedical Engineering* 5: 285–292.
- Yang, C. C., S. S. Jick, and M. A. Testa. 2003. Discontinuation and switching of therapy after initiation of lipid-lowering drugs: the effects of comorbidities and patient characteristics. *British Journal of Clinical Pharmacology* 56: 84–91.

## 10. BIOLOGICALLY-INSPIRED CELLULAR MACHINE ARCHITECTURES<sup>1</sup>

*Gary H. Bernstein, University of Notre Dame*

*Leon O. Chua, University of California at Berkeley*

*Árpád I. Csurgay, University of Notre Dame and Pázmány Péter Catholic  
University*

*Patrick Fay, University of Notre Dame*

*Yih-Fang Huang, University of Notre Dame*

*Wolfgang Porod, University of Notre Dame*

*Ángel Rodríguez-Vásquez, National Microelectronics Center of Spain*

*Botond Roska, Harvard University*

*Tamás Roska, University of California at Berkeley, Pázmány Péter Catholic  
University, Hungarian Academy of Sciences*

*Frank Werblin, University of California at Berkeley*

*Ákos Zarándy, AnaLogic Computers Ltd. and EUTECUS Inc.*

*Abstract:* This chapter describes an NBIC project that is supported through an Office of Naval Research Multidisciplinary University Research Initiative grant. This project presents an example illustrating the synergies emerging from the convergence of nanotechnology, biotechnology, information technology, and cognitive science. Next-generation CNN (Cellular Neural/Nonlinear Network) visual computers will be enhanced by nanoscale sensors, biologically-inspired circuitry, and new, wave-type computing principles. These new generations of systems will have the performance necessary for real-time applications in real-world environments, and they will aid human cognition.

### **Introduction**

In this chapter, we give an overview of an ongoing multidisciplinary research project that serves as an example to highlight the potential and opportunities of Nanotechnology, Biotechnology, Information technology, and Cognitive science (NBIC) convergence. This project, entitled “Biologically-Inspired CNN Image Processors with Dynamically Integrated Hyperspectral Nanoscale Sensors” is funded by the Office of Naval Research through the MURI (Multidisciplinary University Research Initiative) program. Partners, working on the various aspects of NBIC, include for nanotechnology, the Center for Nano Science and Technology at the University of Notre Dame; for biotechnology, the Vision Research Lab at the

---

<sup>1</sup> Aspects of this work were supported through an ONR-MURI grant, NSF-funded international collaborative research projects, and an NSF REU grant.

University of California–Berkeley and the Molecular Vision Laboratory at Harvard; for information technology, the Nonlinear Electronics Research Laboratory at the University of California–Berkeley and the Pazmany University in Budapest, Hungary; and finally, for cognitive science, the Analogical and Neural Computing Laboratory at the Computer and Automation Institute of the Hungarian Academy of Sciences, and two small businesses, AnaLogic Computers Ltd., and EUTECUS Inc. An initial account of this NBIC collaboration was given at the 2003 NBIC Convergence conference (Porod *et al.*, 2004).

This project is concerned with the development of biologically-inspired cellular machine architectures for systems with real-time capabilities to aid human cognition. We utilize recent discoveries in biological image processing (Roska and Werblin, 2001; Werblin *et al.*, 2001; Balya *et al.*, 2002) by translating the underlying functional concepts into the design of Cellular Neural/nonlinear Network–based (CNN) systems incorporating nanoelectronic devices (Chua, 1998). There is a natural intersection joining studies of retinal processing, spatiotemporal nonlinear dynamics embodied in CNN, and the possibility of miniaturizing the technology through nanotechnology. This intersection serves as the springboard for our multi-disciplinary project. Biological feature and motion detectors map directly into the spatiotemporal dynamics of CNN for target recognition, image stabilization, and tracking. The neural interactions underlying color processing drive the development of nanoscale multispectral sensor arrays for image fusion. Implementing such nanoscale sensors on a CNN platform will allow the implementation of device feedback control, a hallmark of biological sensory systems. The goal of this research project is the design and development of several miniature prototype devices for target detection, navigation, tracking, and robotics.

The following sections detail various aspects of our current work. In the NANO section, we describe our ideas of developing sensors for infrared and visible radiation by shrinking to the nanometer scale more-or-less conventional dipole antennas. In the BIO section, we describe research aimed at uncovering nature’s strategies for motion detection and directional selectivity by retinal neurons. We also present a novel molecular, virus-assisted technique to mark the specific circuitry of different ganglion cells and cortical cells *in vivo*, which allows us to “light up” and to “see the circuit” in the living mammalian brain. In the INFO section, we discuss recent work on exploiting nonlinear dynamics for complex spatiotemporal event detection and classification, and we discuss two new cellular architecture concepts; namely, the Star CNN and Dynamic Wave Metric. Finally, such future generations of CNN cellular machine architectures (Roska and Rodriguez-Vazquez, 2001) will provide a platform for COGNO

by taking advantage of nanoscale sensing and processing elements, biologically-inspired circuitry, and new, wave-type computing principles.

### **NANO: Nanoantenna Sensors in the Visible and Infrared Regime**

In order to detect electromagnetic radiation, one needs two basic elements: (1) a physical structure that efficiently couples to the radiation – the antenna – and (2) a rectifying element that converts the high-frequency AC signal to a low-frequency signal that can be detected by electronic means. Antenna structures and rectifying diodes have long been studied and applied for radio waves, television signals, cell phones, and so on. Recent work has shown that miniaturized antennas on the micro- and nanometer scale can be tuned to infrared and visible radiation, and that these nanoantenna structures can be integrated with metal-oxide-metal (MOM) rectifying diodes.

The operation of metal-oxide-metal diodes, also known as metal-insulator-metal (MIM) or metal-barrier-metal (MBM) diodes, combined with antennas is based on the rectification of the high-frequency antenna currents induced by the incident radiation. Because high-quality infrared imaging systems require fast and sensitive detectors that are selective to certain frequencies, these sensors are very promising in this field. Unlike semiconductor-based infrared detectors, these devices can operate at room temperature. Although detectors based on micro-bolometers can also operate at room temperature, those devices are much slower than the antenna-diode structures.

Point-contact MOM diodes combined with wire antennas were first used for detection and mixing at sub-millimeter wavelengths (Dees, 1966). In the following years, these structures were applied to detect radiation at infrared frequencies (Hocker *et al.*, 1968; Faris *et al.*, 1973), and even in the visible range (Daniel *et al.*, 1981). Point-contact devices are not suitable for commercial applications because of their mechanical instability and irreproducibility. With the application of photolithography, stable and reproducible thin-film Ni-NiO-Ni diode-antenna structures were integrated on a substrate (Heiblum *et al.*, 1978). Although the antennas were not suited for the 10.6- $\mu\text{m}$  infrared radiation, these devices gave significant rectified signals at that wavelength. Electron beam lithography made it possible to fabricate diodes with very small contact areas (around  $110 \times 110$  nm), combined with antennas suited for both infrared and visible radiation (Wilke *et al.*, 1994a, 1994b; Fumeaux *et al.*, 1998, 1999). Because a diode with a smaller contact area has a higher cutoff frequency, these devices demonstrate better performance than those made by photolithography.

The Notre Dame group has developed a fabrication procedure for dipole antenna-coupled MOM diodes with ultra-small contact areas (around  $50 \times 50$  nm) suited for the detection of 10.6- $\mu\text{m}$  wavelength infrared radiation. We

fabricated both symmetrical and asymmetrical diodes using a one-step electron beam lithography followed by double-angle evaporation. We fabricated Al-Al<sub>2</sub>O<sub>3</sub>-Al, Al-Al<sub>2</sub>O<sub>3</sub>-Ti, Al-Al<sub>2</sub>O<sub>3</sub>-Pt, and Ni-NiO-Pt diodes, and we studied the DC characteristics of these devices. The asymmetrical MOM diodes are nonlinear even when unbiased, leading to a lower noise level and thus better performance.

MOM diodes consist of two metal layers separated by an oxide layer. Because the oxide is an insulator, charges can flow from one side to the other either by being energetic enough to overcome the potential barrier (thermionic emission) or by direct “tunneling” through the barrier (quantum mechanical tunneling for sufficiently thin barriers). The energy diagram of a symmetrical and asymmetrical diode is displayed in Figure 1. Of particular interest here is quantum mechanical tunneling because it is very fast and the nonlinear behavior of the tunneling current-voltage characteristics can be used for the rectification of alternating currents.

**Figure 1. Schematic Drawing of Symmetrical (Top) and Asymmetrical (Bottom) MOM Structures**

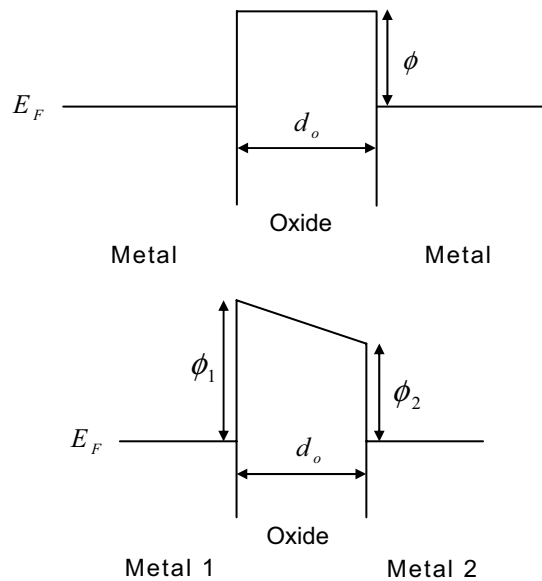

The fabrication of MOM diodes for our purposes is rather challenging, as the contact area needs to be very small (required small junction capacitance), and the oxide layer has to be very thin in order to yield useful current levels (the tunneling current depends exponentially on the oxide thickness). The

Notre Dame group has been working on this challenge in the context of a different problem; namely, ultra-small tunnel junctions for single-electron transistors (Snider *et al.*, 1999). For a junction with a capacitance of attofarads ( $10^{-18}$  F), the transfer of a single electron (with charge  $e = 1.6 \times 10^{-19}$  coulombs) leads to a change in voltage of 0.16 V, which may be exploited for single-electron device applications. The Notre Dame group now is able to routinely fabricate MOM diode structures with a contact area on the order of  $50 \times 50$  nm and oxide thicknesses around 1 or 2 nm.

The antenna structures were fabricated on an oxidized, 11–16- $\Omega$ -cm *p*-type silicon wafer, around 625  $\mu\text{m}$  thick (Rakos *et al.*, 2005). The approximately 1.5- $\mu\text{m}$ -thick silicon dioxide layers on the top and the bottom of the wafer were grown by wet oxidation for 210 minutes at 2000°C. The oxide layer acts as an insulator between the devices and the silicon layer, and it serves as a quarter-wave matching layer for the roughly 10- $\mu\text{m}$  infrared radiation (Wilke *et al.*, 1994a, 1994n).

The sensor consists of a MOM diode integrated together with a dipole antenna. Detection of the 10.6- $\mu\text{m}$  infrared radiation requires a 3- $\mu\text{m}$ -long dipole antenna. We fabricated the devices with a one-step electron beam lithography combined with double-angle evaporation and oxidation, schematically shown in Figure 2. This process is simple and stable and permits a controlled oxidation, as the sample can be kept in the vacuum chamber. After the deposition of the first metal layer, oxygen is introduced into the chamber at a certain pressure for a certain time, and the second evaporation can be done at another angle by tilting the sample stage. Tunnel junctions for the realization of single-electron transistors have already been fabricated with this method (Snider *et al.*, 1999). A variation of this process is to expose the sample to air between metal evaporations.

During the double-angle evaporation process, a metal layer is first deposited through an opening in a two-layer resist mask (in our case, at around  $7^\circ$  with respect to normal incidence). Then, this deposited metal structure is oxidized. The oxidation process is indicated in Figure 2 by the thick border. Then, another metal layer is deposited at another angle (in our case,  $-7^\circ$ , with respect to the vertical incidence). In this way, the pattern is shifted, and the small overlap between the two subsequent metal layers forms the MOM diode. In this way, we are able to fabricate diode structures with an overlap area of around  $50 \times 50$  nm.

An electron micrograph of a typical antenna-diode structure is shown in Figure 3, as the left image. The right image shows a close-up view of the overlap area in the center, which results from the double-angle evaporation process. We fabricated Al-Al<sub>2</sub>O<sub>3</sub>-Al, Al-Al<sub>2</sub>O<sub>3</sub>-Ti, and Al-Al<sub>2</sub>O<sub>3</sub>-Pt structures with this process (Rakos *et al.*, 2005). The Al-Al<sub>2</sub>O<sub>3</sub>-Al diodes were made both with oxidation in air and with oxidation at 60 mTorr for 10 minutes. The Al-Al<sub>2</sub>O<sub>3</sub>-Ti and Al-Al<sub>2</sub>O<sub>3</sub>-Pt diodes were fabricated with oxidation in air.

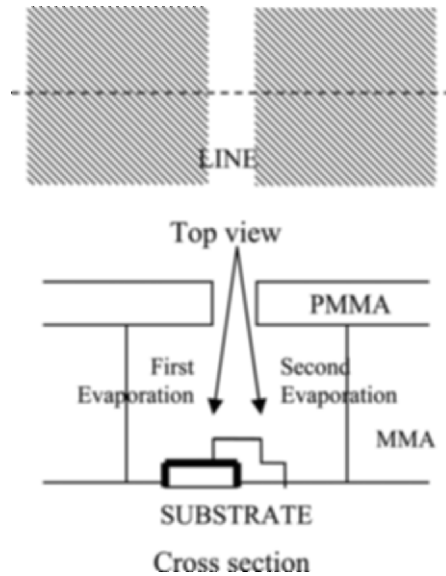
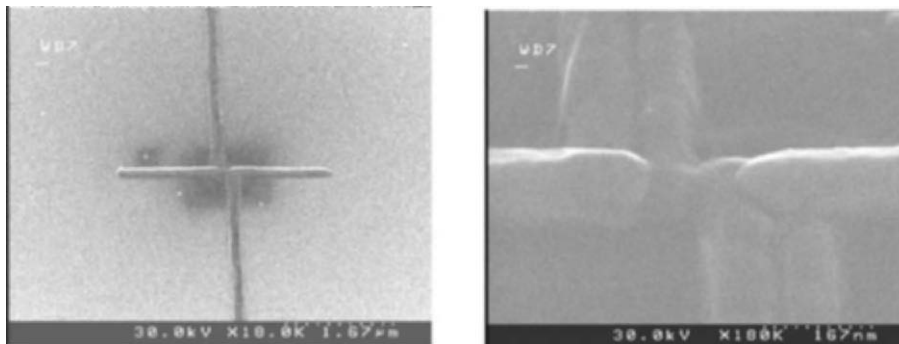

**Figure 2. Schematic of the Double-Angle Evaporation Process****Figure 3. An Antenna-Coupled MOM Structure**

An important feature of such antenna-coupled MOM detectors is that they can be naturally integrated with silicon circuitry on the same chip, as all fabrication steps are compatible. This opens up the possibility of integrating these detectors directly inside each processing element of a cellular architecture, without the performance bottleneck incurred when sensing and processing have to be done on separate platforms.

**BIO: Uncovering Nature's Neuronal Circuitry**

The computation of the direction of movement of an object in the visual scene has fascinated visual neuroscientists for nearly four decades. Recent advances in our understanding of this phenomenon have revealed a complexity and sophistication of design never before imagined. This section outlines the methodology for studying this phenomenon and presents the results of recent studies. This work was performed in the group of Professor Frank Werblin at the Vision Research Laboratory, University of California–Berkeley; team members include Shelley Fried and Thomas Münch.

*Computation of Directional Selectivity by Retinal Neurons*

In the mid-1960s Barlow and Levick (1965) showed that certain retinal ganglion cells (directional selectivity, or DS cells) responded best to movement in specific directions. Four classes of such cells were found with movement preference along the axes of the insertions of the main extra four ocular muscles that move the eye, roughly along the vertical and horizontal axes (Oyster *et al.*, 1993). They showed also that movement over very small regions of each cell's receptive field showed similar directional properties, indicating that the phenomenon was composed of smaller "directionally selective subunits" that populated the entire receptive field. A sketch of the conclusions of Barlow and Levick is shown in Figure 4, showing movement-detecting subunits (MDS) interacting in an asymmetrical way, inhibiting from right to left, thereby allowing movement to be detected from left to right.

Some years ago, Famiglietti (1991) showed that starburst amacrine cells co-fasciculate with the DS cells at two regions of the inner retinal neuropil corresponding to regions of ON and OFF sensitivity. Famiglietti also showed that the output from starburst cells was confined to the outer regions of the starburst cells, whereas the input regions were found everywhere. The starburst morphology is shown in Figure 5. Furthermore, it has been recently shown that the tips of the processes of these cells are directionally selective (Euler *et al.*, 2002).

These studies laid the groundwork for our understanding of directional selectivity, but like most good work, they raised more questions than they answered. The questions generated by these findings were: How are the starburst and DS cells synaptically related, and how do synaptic interactions between these cells mediate directional selectivity? To answer these questions, we measured communication between these two cell types and found that the starburst cells on the null side of the DS cell acted to inhibit the DS cell, but starburst cells on the preferred side had no effect. This study

identified the components of the model proposed by Barlow and Levick 38 years later, and provided the springboard for further studies.

The Barlow and Levick model identifies the interaction of excitation and inhibition at the membrane of the DS cell as the computational element in DS. But the actual interactions are much more elaborate and sophisticated than that. We found, for example, that the two inputs, excitation and inhibition, were themselves directionally selective, placing the site of DS computation at multiple levels much further back in the processing of the visual message than the dendrites of the DS cells (Fried *et al.*, 2002).

**Figure 4. The Barlow and Levick Model of Movement Detection**

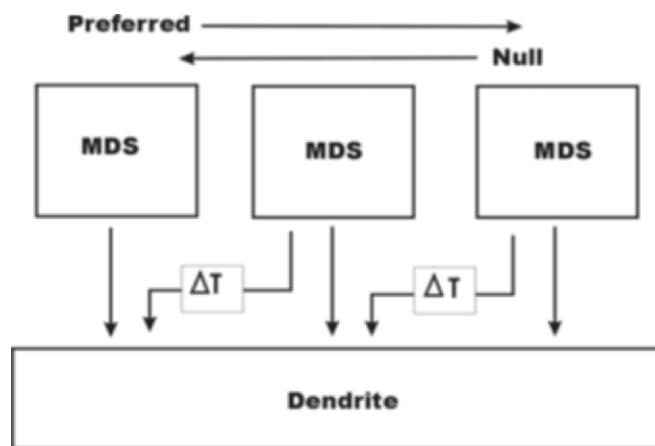

**Figure 5. Starburst Cell Morphology Showing Beautiful Symmetry**

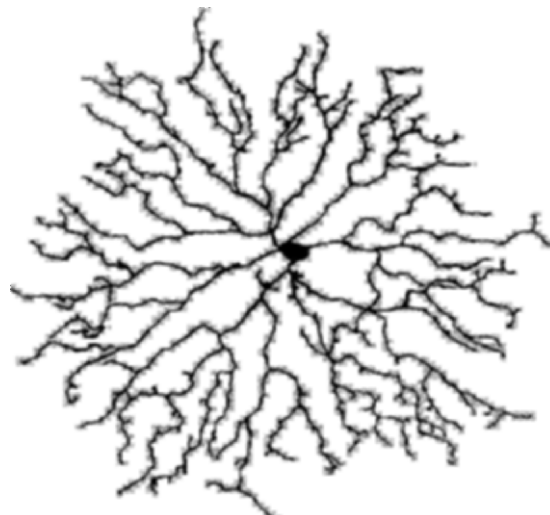

But by what mechanism do the two inputs themselves achieve directional selectivity? To answer this question we had to resort to an indirect method of measurement, because our main access to the system was at the DS cell itself, yet we were now looking for a mechanism that lay much deeper in the retina than the DS cells – somewhere in neurons that made the inputs to the DS cell directional. To solve this problem, we borrowed from the strategy of Barlow and Levick. Because scientific methodology was more primitive in their time, Barlow and Levick had access only to the output of the DS cell, yet they were able to infer interactions at the cell's inputs. We now had access to the cells' inputs and wanted to infer interactions at the next higher level, where those inputs were made directional.

We asked this question: Was the directional property of the input caused by an enhancement of activity in the preferred direction or a suppression of activity in the opposite or null direction? The technique used was to simulate movement in either direction with a sequence of two flashes. Imagine three positions moving from left to right, and call the positions A, B, and C. Position B will always be the test flash. The sequence A–B simulates movement in the preferred direction, with position A being the conditioning flash and position B being the test flash. The sequence C–B simulates movement in the null direction, with position C being the conditioning flash. We found that excitation was suppressed for movement in the null direction but unaffected by movement in the preferred direction. Conversely, we found that inhibition was suppressed by movement in the preferred direction but unaffected by movement in the null direction.

At this point, our best guess as to the connectivity in the system that mediates directional selectivity is shown in Figure 6. There is an interaction between starburst cells that is mutually inhibitory. This connection is tonically active, so any perturbation tends to enhance the difference in bias between the pairs of starburst cells mediating movement in opposite directions. Starburst cells on the null side make contact with the DS cell, and they are suppressed for movement in the preferred direction by neighboring starburst cells pointing in the opposite direction. The null-side starburst cells also make inhibitory contact with the axon terminals of the bipolar cells, thereby suppressing the excitatory input to the DS cell.

In the left panel of Figure 7, DS cells receive both excitatory glutamate and excitatory ACh input along their dendritic extents. Dashed arrows indicate that the ACh input pathways exist but are normally suppressed. DS cells receive an inhibitory input via GABA receptors, but only from the null side. The right panel shows suppressive effects upon excitation and inhibition. The GABA inhibition is suppressed from the preferred side by pathways that, for the ON system, involve an ACh synapse. The excitatory inputs are suppressed from the null side by GABA-mediated inhibition.

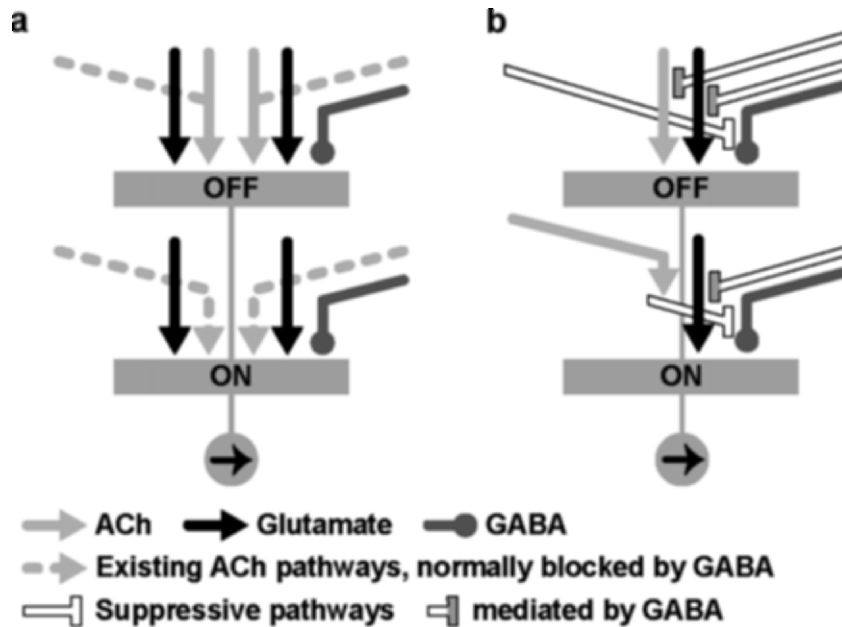
**Figure 6. Connectivity in the System Mediating Directional Selectivity***Lighting up Local Circuits in the Living Mammalian Brain*

This section presents novel molecular, virus-assisted techniques to mark the specific circuitry of different ganglion cells and cortical cells *in vivo*, which allows one to “light up” and to “see the circuit” in the living mammalian brain. This work was performed in the group of Dr. Botond Roska in the Molecular Vision Laboratory at Harvard University.

The mammalian visual system analyzes the world through a set of separate spatiotemporal channels. The organization of these channels begins in the retina, where the precise laminations of both the axon terminals of bipolar cells and the dendritic arbors of ganglion cells form a vertical stack of neural strata (Figure 7) at the inner plexiform layer (IPL). The retina also incorporates an extremely diverse population of amacrine cells. These inhibitory interneurons can perform local or global processing; moreover, many inhibitory amacrine cell classes are multi or diffusely stratified, suggesting that they might convey information between strata.

Each ganglion cell type receives unique and substantively different excitatory and inhibitory neural inputs from a subset of strata that are integrated to form at least a dozen different, parallel space-time spiking outputs (Roska and Werblin, 2001). The IPL therefore contains a parallel set of representations of the visual world, embodied in the strata, and conveyed

to higher centers by the classes of ganglion cells whose dendrites ramify at that stratum.

The highly refined stratification patterns of ganglion, bipolar, and amacrine cells suggest that each ganglion cell type is using a subset of amacrine and bipolar cell types to process visual information. A major challenge is to understand how the different “visual features” extracted by different ganglion cell types are computed by each ganglion cell type-specific circuitry. More generally, at each level of visual processing from the periphery to the cortex, a major challenge is to understand how different visual features are extracted by local circuits.

In order to reach this goal, we applied novel molecular, virus-assisted techniques to mark the specific circuitry of different ganglion cells and cortical cells *in vivo* and then, with the benefit of being able to “see the circuit,” apply electrophysiological techniques to reveal how the specific connectivity of a ganglion cell type leads to distinct neural representations.

**Figure 7. Diagram of the Pupil Reflex Pathway and Site of Virus Injection**

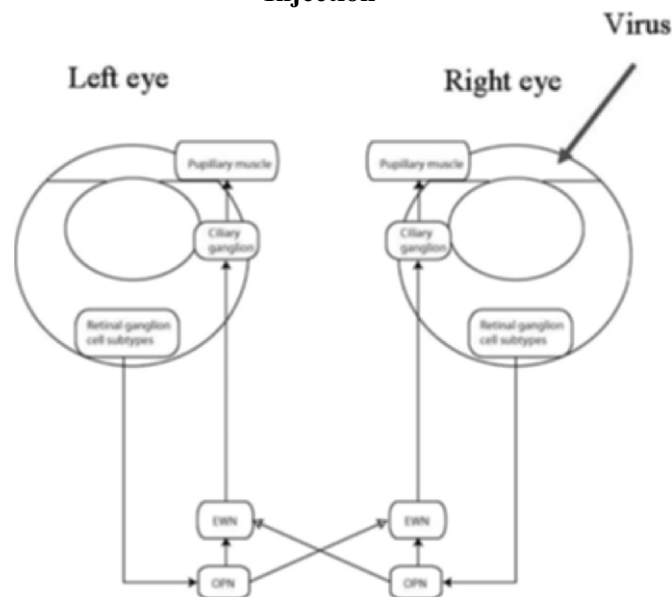

Recently, different genetically engineered pseudorabies virus (PRV) strains were introduced (Smith *et al.*, 2000; Boldogkoi *et al.*, 2002) as powerful tools for neural circuitry mapping. PRVs are neurotropic and spread trans-synaptically between synaptically-connected neurons. Both retrogradely and anterogradely moving PR mutants exist. Virus strains containing a gene for the green fluorescent protein (GFP) were engineered so that each neuron in the connected circuitry could be lit up by the trans-

neuronal spread of the virus. This makes it possible to visually target recording electrodes to the specific cells that are connected.

In the retina, all ganglion cells have receptors for the PRV virus. Therefore all ganglion cells become infected by injecting the virus to the eye. To overcome this limitation and label the circuitry of specific ganglion cells *in vivo*, using retrograde GFP expressing PRV viruses, one can inject the virus into distant brain regions where only a few ganglion cell types project. The virus then moves backward through the projections of the ganglion cell to “light up” the circuits of those ganglion cells.

It was shown recently that injecting a retrograde GFP-expressing PRV (PRV 152) into one eye leads to viral GFP expression in subclasses of ganglion cells in the other eye (Smith *et al.*, 2000). It was also shown that the virus retrogradely follows the neural pathway of the pupil reflex, as schematically indicated in Figure 7. To light up the specific circuits of those ganglion cells, we injected PRV 152 or DupGFP, a less virulent PRV mutant, into the right eye of mice and examined the left eye under confocal microscope in different postinjection time periods. After 3.5 days, several ganglion cells were brightly fluorescent. The ganglion cells could be quantitatively divided into three groups on the basis of their dendritic stratification.

Figure 8 shows one of these cells; the arrow points to the axon. Figure 9 shows a pyramidal cell in layer 5 of V1. A three-dimensional reconstruction was made from a confocal stack from a cortical slice. Here the two-dimensional projection of the reconstruction is shown.

The finding that we were able to label ganglion cells by cortical injections suggested that this method allows the determination of cortical microcircuits as well. We injected, therefore, higher visual cortical areas (V2) in mice and looked for green fluorescence in the coronal sections of primary visual cortex (V1). At low virus titers, several brightly labeled cells and local circuits could be seen. Figure 10 shows a cortical circuit in V1 after virus injection to V2. The different cortical layers are labeled in roman numbers.

In summary, we have described a novel technique to “light up” local circuits in living mammalian brains. The benefit of being able to see the circuits in living neural tissue made it possible, in related work, to record activity from neurons of connected local circuits. Our ability to now directly see the detailed circuitry in the mammalian retina and brain will be an important tool in abstracting nature’s circuit designs and in using them for nature-inspired, man-made circuits.

**Figure 8. A Brightly Florescent Ganglion Cell**

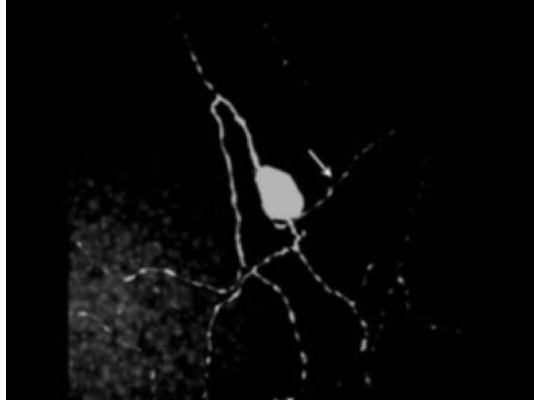

**Figure 9. Reconstruction of a Pyramidal Cell**

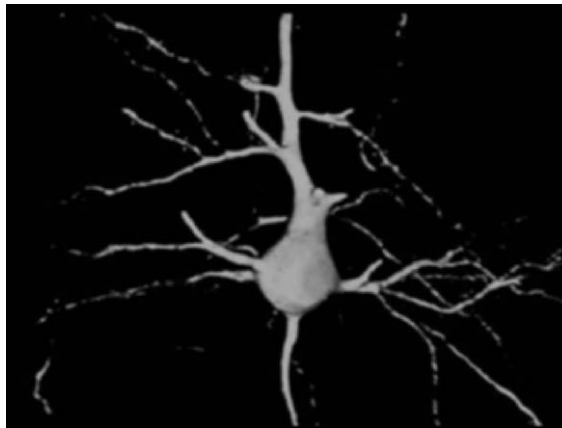

**Figure 10. A Cortical Circuit**

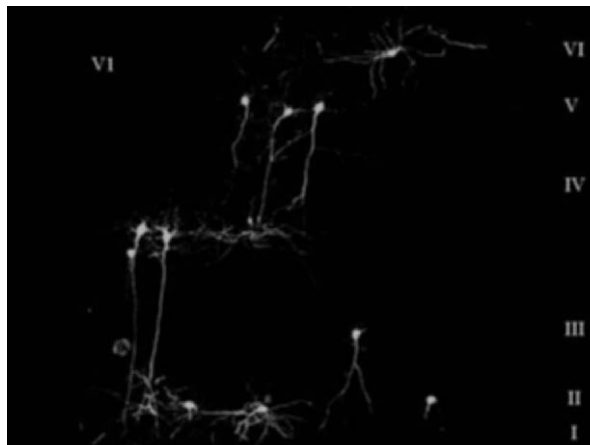



**INFO: Star Cellular Neural Networks and Dynamic Wave Metric**

This ongoing research focuses on exploiting nonlinear dynamics for achieving dynamic associative memories and dynamic wave metric focusing on complex spatiotemporal event detection and classification. The work described in this section was performed in Professor Leon Chua's Nonlinear Electronics Research Laboratory at the University of California–Berkeley.

In a complex environment, where a large volume of information is continuously arriving from multiple sensors and needs to be processed in a mission-critical manner, the demand for supercomputing power makes standard digital and sequential designs inappropriate. Massively parallel architectures are necessary to provide a medium in which these analog sensor signals can be analyzed and processed. These complex, nonlinear spatiotemporal processes require new methodologies to extract and classify information in real-time. To detect dynamical events and wave processes on a two-dimensional array of signals (as in image processing) requires more than single two-dimensional pattern recognition. Computing architectures based on the CNN paradigm and the CNN Universal Machine (CNN-UM) offer an adequate solution for processing spatiotemporal dynamical events (Chua and Yang, 1988a, 1988b; Chua and Roska, 1993; Roska and Chua, 1993; Chua, 1998). Our aim is to explore the potential of nonlinear dynamics in detecting, recognizing, and classifying complex events. Object (event) detection and classification is a hard and challenging problem in which nonlinear dynamics presents a very promising tool to target these difficulties. We focused on two research problems; namely, how to measure object properties and how to classify them.

The concept of associative memories shows great potential to classify objects even if they are corrupted or detected in a very noisy environment. Here, we propose a new architecture called Star Cellular Neural Network (Star CNN) for associative memories, which is based on the star topology and chaotic synchronization (Itoh and Chua, 2004). A Star CNN is a dynamic nonlinear system defined by connecting  $N$  identical dynamical systems in the shape of a star. All local cells communicate with each other through a central system. This topology can easily be implemented in hardware using only  $N$  connections, except that a central cell has to supply complicated signals. A Star CNN can store and retrieve complex oscillatory patterns in the forms of synchronized chaotic states (associative memories).

Object comparison usually requires feature extraction and some kind of distance calculation to reference data. Spatiotemporal processes offer a new approach to exploring object properties and provide an efficient tool to compute novel metrics. The basic idea of a dynamic wave metric is to explore geometric (structural and morphological) properties of objects via propagating nonlinear waves in a dynamical medium (Szatmári *et al.*, 1999).

The extracted information makes it possible to compute several metrics for similarity and difference measurements. All this can take place on a cellular analogic wave computer (Szatmári, 2003). The dynamic wave metric not only measures static features of objects but inherently also includes hidden dynamical information on object properties in contrast to standard and common distance measures.

#### *CNN Star Architecture*

There are four principal network topologies in local area networks; namely, bus topology, mesh topology, star topology, and ring topology. (A tree topology combines characteristics of bus and star topologies.) In a star topology, all cells are connected to a central cell. The advantage of the star topology is that if one cell fails, then only the failed cell is unable to send or receive data. The star networks are relatively easy to implement but have potential bottlenecks and failure problems at the central cell because all data must pass through this central cell. For associative and dynamic memories, a Star CNN consists of local oscillators and one central cell. All oscillators are connected to a central system and communicate to each other through the central cell. This architecture can store and retrieve given patterns in the form of synchronized states with appropriate phase relations between oscillators (associative memories). Furthermore, according to our results, the star CNN can function as dynamic memories; that is, its output pattern can occasionally travel around the stored patterns, their reverse patterns, and new relevant patterns (spurious patterns). This is also motivated by the observation that a human being's associative memory is not always static, but sometimes wanders from a certain memory to another memory, one after another. Furthermore, a flash of inspiration (new pattern) sometimes appears that is relevant to known memories. A change in memory also sometimes seems to be chaotic. Our proposed Star CNN can function as both associative (static) and dynamic memories.

#### *Dynamic Wave Metric*

The developed methodology to explore geometrical properties of two-dimensional objects is based on spatiotemporal nonlinear waves propagating along a nonlinear medium. The extracted information measures both differences and similarities among the objects and their reference models. The concept of wave phenomena is useful to develop qualitatively novel metrics and distance measures. It is also shown that it can be efficiently implemented on existing VLSI implementations of CNN-UM. Measurements based on a dynamic wave metric contain much more information than do common metrics like Hausdorff or Hamming metrics. There are also

examples in which Hausdorff and Hamming metrics completely fail and cannot distinguish certain object properties. These drawbacks can be avoided by nonlinear wave metric computation. The novelty of this approach is that objects are explored via spatiotemporal dynamic processes, and the dynamics during the wave evolution are recorded and stored in a so-called wave map. Along spatial features as a new dimension, time-related information can be extracted and makes it possible to investigate “hidden” properties of objects. From this wave map, several simple metrics can be derived, along with more sophisticated ones that make it possible to classify objects in a number of non-trivial cases. The nonlinear wave mapping-based metric computation consists of three parts, as follows. The first projection extends spatial information into a spatiotemporal one (in addition to spatial dimensions, time is involved also). Transformations thereafter compress spatiotemporal information by reducing spatial and temporal dimensions into a single real number that finally gives the result of the metric computation. The method was demonstrated on existing VLSI implementations of analogical cellular wave computers. Implemented metric measurements have shown good correlation with theoretical data.

### **COGNO: Towards Future Generations of Systems with Cognitive Capabilities**

The work described here will contribute to future generations of systems with enhanced cognitive capabilities. Specifically, the collaborative NBIC project outlined here has several objectives.

New sensory-computing-activating cellular architectures and algorithms will be developed that reflect the structures, techniques, and capabilities learned from the recent breakthrough results related to vision, and in particular to the mammalian retina and to the planned new studies in the higher levels of the visual pathway.

A genuine combination of analog, logic, and digital signals will be used and implemented in the architectural framework of an advanced CNN-UM sensory array computing device, using both deep submicron as well as nanoscale technologies, to dynamically integrate the sensory and computing functions onto the surface of a single device.

Focal plane sensing, fusion, and computing, including automatic target recognition and tracking, will be made by using the latest complex and mathematically sophisticated methods, including techniques based on partial differential equations, Level-set Theory, and the integrated spatiotemporal-spectral techniques. All these methods will lead to brand-new, mission critical devices and systems, with unprecedented technical and functional parameters, such as hand-held surveillance and multiple-target tracking systems with a thousand times speed increase (about 50,000 frames per

second, or supercomputer speed in a fist-size device for vision), all with a functional sophistication we can witness now only in champion species of nature.

## Conclusion

In this chapter, we gave an overview of an ongoing multidisciplinary research project, and we hope that our work serves as an example to highlight the potential and opportunities of NBIC convergence. We described how next-generation CNN (Cellular Neural/Nonlinear Network) visual computers will be enhanced by nanoscale sensors, biologically-inspired circuitry, and new, wave-type computing principles. These new generations of systems will have the performance necessary for real-time applications in real-world environments, and they will find applications in enhancing human performance.

A multi-disciplinary collaboration, similar to the one described here, poses many challenges, especially when so many disciplines are involved, and interactions are required over great geographical distances. It is a real challenge to make such a collaboration happen, and we are very fortunate to have a team with the right “chemistry” and past history. Very important in forming this team were previous National Science Foundation–sponsored international collaborative research projects between the University of California–Berkeley and the Hungarian Academy of Sciences on the one hand, and Notre Dame and the Technical University of Budapest and Pazmany University on the other. This team, or subsets thereof, has a history of frequent visits and exchanges over the past decade or two, and this MURI project “gelled” in this environment of interdisciplinary and international exchange among individuals with a desire to collaborate.

In addition to research, education is an important component of this team effort. There is an active exchange of students and visitors among the partners, and especially an international exchange between University of California–Berkeley and Budapest, and Notre Dame and Budapest. We recently also received funds from the National Science Foundation for a nano-bio REU (research experiences for undergraduates) site at Notre Dame,<sup>1</sup> and this summer research experience includes undergraduate research experiences related to the work described here. In addition, this REU program also features an international component, with Hungarian students participating in research at Notre Dame, and U.S. students traveling to Budapest to visit labs there. Another interdisciplinary educational initiative is a freshman-level seminar course on nanotechnology at Notre Dame

---

<sup>1</sup> [www.nd.edu/~nanoreu/](http://www.nd.edu/~nanoreu/)

(SC190),<sup>1</sup> which includes aspects from the various disciplines, as well as discussion of ethical considerations and societal impact.

## References

- Balya, D., B. Roska, T. Roska, and F. S. Werblin. 2002. A CNN framework for modeling parallel processing in a mammalian retina. *International Journal of Circuit Theory and Applications* 30: 363–393.
- Barlow, H. B., and W. R. Levick. 1965. *Journal of Physiology-London* 178: 477–504.
- Barlow, H. B., and R. M. Hill. 1963. Selective sensitivity to direction of motion in ganglion cells of the rabbit's retina. *Science* 139, 412–414.
- Boldogkoi, Z., A. Reichart, I. E. Toth, A. Sik, F. Erdelyi, I. Medveczky, C. Llorens-Cortes, M. Palkovits, and Z. Lenkei. 2002. Construction of recombinant pseudorabies viruses optimized for labeling and neurochemical characterization of neural circuitry. *Brain Research: Molecular Brain Research* 109(1–2): 105–18.
- Chua, L. O. 1998. *CNN: A Paradigm for Complexity*. Singapore: World Scientific.
- Chua, L. O., and L. Yang. 1988a. Cellular neural networks: Applications. *IEEE Transactions on Circuits and Systems* 35: 1273–1290.
- Chua, L. O., and L. Yang. 1988b. Cellular neural networks: Theory. *IEEE Transactions on Circuits and Systems* 35: 1257–1272.
- Chua, L. O., and T. Roska. 1993. The CNN paradigm. *IEEE Transactions on Circuits and Systems* 40: 147–156.
- Csurgay, A. I., and W. Porod. 2001. Equivalent circuit representation of arrays composed of Coulomb-coupled nanoscale devices: Modelling, simulation and realizability. *International Journal of Circuit Theory and Applications* 29: 3–35.
- Daniel, H. U., M. Steiner, and H. Walther. 1981. Response of metal-insulator-metal point contact diodes to visible laser light. *Applied Physics* 25: 7–12.
- Dees, J. W. 1966. Detection and harmonic generation in the submillimeter wavelength region. *Microwave Journal* 9: 48–55.
- Euler, T., P. B. Detwiler, and W. Denk. 2002. Directionally selective calcium signals in dendrites of starburst amacrine cells. *Nature* 418: 845–852.
- Famiglietti, E. V. 1991. Synaptic organization of starburst amacrine cells in rabbit retina: Analysis of serial thin sections by electron microscopy and graphic reconstruction. *Journal of Comparative Neurology* 309, 40–70.
- Faris, S.M., Gustafson, T. K. Wiesner, J. C. 1973. Detection of optical and infrared radiation with DC-biased electron-tunneling metal-barrier-metal diodes. *IEEE Journal of Quantum Electronics* 9(7): 737–745
- Fried, S. I., T. A. Münch, and F. S. Werblin. 2002. Mechanisms and circuitry underlying directional selectivity in the retina. *Nature* 420: 411–414.
- Fumeaux, C., J. Alda, and G. D. Boreman. 1999. Lithographic antennas at visible frequencies. *Optics Letters* 24: 1629.

---

<sup>1</sup> [www.nd.edu/~ndnano/SC190/](http://www.nd.edu/~ndnano/SC190/)

- Fumeaux, C., W. Herrmann, F. K. Kneubühl, and H. Rothuizen. 1998. Nanometer thin-film Ni-NiO-Ni diodes for detection and mixing of 30 THz radiation. *Infrared Physics and Technology* 39: 123–183.
- Gerousis, C., S. M. Goodnick, and W. Porod. 2000. Toward nanoelectronic cellular neural networks. *International Journal of Circuit Theory and Applications* 28: 523–535.
- Heiblum, M., S. Wang, J. R. Whinnery, J.R., and T. K. Gustafson. 1978. Characteristics of integrated MOM junctions at dc and at optical frequencies. *IEEE Journal of Quantum Electronics* 14: 159–169.
- Hocker, L. O., D. R. Sokoloff, V. Daneu, A. Szoke, and A. Javan. 1968. Frequency mixing in the infrared and far-infrared using a metal-to-metal point contact diode. *Applied Physics Letters* 12: 401–402.
- Itoh, M., and L. O. Chua. 2004. Star cellular neural networks for associative and dynamic memories. *International Journal of Bifurcation and Chaos* 14(5): 1725–1772.
- Oyster, C. W., F. R. Amthor, and E. S. Takahashi. 1993. Dendritic architecture of ON-OFF direction-selective ganglion cells in the rabbit retina. *Vision Research* 33: 579–608.
- Porod, W. 2002. Nanoelectronic circuit architectures. Pp. 5.1–5.10 in W. A. Goddard, D. W. Brenner, S. E. Lyshevski, and G. J. Iafrate (eds.), *Handbook of Nanoscience, Engineering, and Technology*. Boca Raton, Fla.: CRC Press.
- Porod, W., C. S. Lent, G. Toth, H. Luo, A. Csurgay, Y.-F. Huang, and R.-W. Liu. 1997. Quantum-dot cellular nonlinear networks: Computing with locally-connected quantum dot arrays. Pp. 745–748 in *Proceedings of the 1997 IEEE International Symposium on Circuits and Systems: Circuits and Systems in the Information Age*.
- Porod, W., C. S. Lent, G. H. Bernstein, A. O. Orlov, I. Amlani, G. L. Snider, and J. L. Merz. 1999. Quantum-dot cellular automata: Computing with coupled quantum dots. *International Journal of Electronics* 86(5): 549–590.
- Porod, W., F. Werblin, L. O. Chua, T. Roska, A. Rodriguez-Vazquez, B. Roska, P. Fay, G. H. Bernstein, Y.-F. Huang, and A. Csurgay. 2004. Bio-inspired nanosensor-enhanced CNN visual computer. Pp. 92–109 in M. C. Roco and C. D. Montemagno (eds.), *The Coevolution of Human Potential and Converging Technologies*. New York: New York Academy of Sciences.
- Rakos, B., G. H. Bernstein, P. Fay, and W. Porod. 2005. Manuscript in preparation.
- Roska, B., and F. Werblin. 2001. Vertical interactions across ten parallel, stacked representations in the mammalian retina. *Nature* 410(6828): 583–587.
- Roska, T., and L. O. Chua. 1993. The CNN universal machine: An analogic array computer. *IEEE Transactions on Circuits and Systems* 40: 163–173.
- Roska, T., and Á. Rodríguez-Vázquez (eds.). 2001. *Towards the Visual Microprocessor*. New York: Wiley.
- Smith, B. N., B. W. Banfield, C. A. Smeraski, C. L. Wilcox, F. E. Dudek, L. W. Enquist, and G. E. Pickard. 2000. Pseudorabies virus expressing enhanced green fluorescent protein: A tool for *in vitro* electrophysiological analysis of transsynaptically labeled neurons in identified central nervous system circuits. *Proceedings of the National Academy of Sciences USA* 97(16): 9264–9269.

- Snider, G. L., A. O. Orlov, I. Amlani, X. Zuo, G. H. Bernstein, C. S. Lent, J. R. Merz, and W. Porod. 1999. Quantum-dot cellular automata: review and recent experiments. *Journal of Vacuum Science and Technology A* 17(4): 1394–1398.
- Szatmári, I. 2003. Spatio-temporal nonlinear wave metric for binary and gray-scale object comparison on analogic cellular wave computers. DNS-15 Progress Report, Computer and Automation Research Institute of Hungarian Academy of Sciences.
- Szatmári, I., C. Rekeczky, and T. Roska. 1999. A nonlinear wave metric and its CNN implementation for object classification. *Journal of VLSI Signal Processing* 23(2/3): 437–447.
- Werblin, F. S., B. Roska, and D. Balya. 2001. Parallel processing in the mammalian retina: lateral and vertical interactions across stacked representations. *Progress in Brain Research* 131: 229–238.
- Wilke, I., W. Herrmann, and F. K. Kneubühl. 1994a. Integrated nanostrip dipole antennas for coherent 30-THz infrared radiation. *Applied Physics B* 58: 87–95.
- Wilke, I., Y. Oppliger, W. Herrmann, and F. K. Kneubühl. 1994b. Nanometer thin-film Ni-NiO-Ni diodes for 30-THz radiation. *Applied Physics A* 58: 329–341.

## 11. COGNITIVE ENHANCEMENT AND THE NEUROETHICS OF MEMORY DRUGS

*Wrye Sententia, Ph.D., Center for Cognitive Liberty and Ethics*

*Abstract:* In response to recent developments in neuropharmacology, some are asking what the potential impact of memory drugs might be in relation to common values and social justice; others are concerned with legal and military implications, including possible requirements or prohibitions of enhancement pharmaceuticals in the workplace. In considering these drugs, society must weigh what the collective benefits or costs might be in relation to individual rights and choices. This chapter addresses the neuroethics of memory drugs by taking stock of differing rhetorics and values in personal and collective memory. Following an overview of current “memory and forgetting” drug development, this chapter asserts the idea that cultural shifts in how we relate to history in general, and to our own stories or memories in particular, can open up approaches to scientific knowledge that carry ethical social advantages. As changes in memory management, both technological and pharmacological, come into play, freedom of thought remains a democratic good and an essential human value that can guide coming debates over the uses and applications of cognitive technologies.

### Introduction

Not everything that can be counted counts, and not everything that counts can be counted.

–Albert Einstein

Exciting developments in the neurosciences and related technologies are opening a floodgate of interest in the potential enhancement of cognitive capabilities as well as increasing debate over the ethics and social viability of such interventions in human cognition. Nanotechnology, biotechnology, information technology, and cognitive sciences (NBIC) convergence engages neurocognitive enhancement in a number of applications (e.g., Roco and Bainbridge, 2003; Lynch, 2002; Grill and Kirsch, 2000; Snyder *et al.*, 2003). Generally, “human performance enhancement” refers to the augmentation of human ability (skills, attributes, or competencies) through the use of technology, medicine, or therapy aimed at improving a person’s ability to perform in a given area (Juengst, 1998; Shapiro, 2002). “Neurocognitive enhancement” denotes those technologies and drugs that improve “normal” human capabilities by enhancing, improving, or altering cognition (as with mood, memory, and attention) for better ability (McGaugh, 1991; Gerlai, 2003; Caplan, 2003). Increasingly, new advances in health products,



including neural or cognitive prostheses, in scientific practices of pharmacogenomics, bioinformatics, and neuropharmacology, as well as in long-term prospects of computer-to-brain interface systems, define areas in which NBIC convergence touches on issues of human cognition and the complexities of human thinking in groups and as individuals. Although the application of some of these advancements may still be decades away, authors of a recent *Nature Reviews Neuroscience* article acknowledge that the normal enhancement of neurocognitive function with drugs “is already a fact of life for many people,” and further, that psychopharmacology is increasingly used for improving the psychological function of individuals who are not ill (Chatterjee, 2004; Farah *et al.*, 2004).

One important area of research and development (R&D) in improving normal neurocognitive capabilities, then, is with memory medicines. Because the function of memory is so central to constituting ourselves as individuals and as thinking and acting social beings, interest in memory drugs as cognitive enhancers will impact the legal, ethical, and social landscape sooner, rather than later. Memory drugs are ostensibly being developed for the therapeutic treatment of age-related cognitive decline. With 21 million people expected to have Alzheimer’s Disease (AD) by the year 2010 (de la Torre, 2004), improvements for the elderly are a key motivator behind massive current research into memory deficit/enhancing drugs. More broadly, 78 million “baby boomers,” representing the largest concentration of wealth of any demographic population on the planet (Canton, 2004), are a major market for memory medicines. Recent and emerging developments in related fields of neuropharmacology, suggest a pressing need to consider the potential impact of memory drugs on how we think about our right to think, with or without therapeutic enablers, and about what the social benefits or costs of such drugs might be.

### **Neuroethics of Memory Management**

Concerned professionals have only just begun to grapple with the novel social issues raised by potential uses of neurocognitive enhancement applications, as implied by the novelty of the term, “neuroethics,” itself (Farah, 2002; Marcus, 2002; Caplan, 2003; Illes *et al.*, 2003; Greely, 2004; Sentientia, 2004). Yet, although rampant coverage of bioethical issues fills the pages of medical journals, references to neuroethical quandaries remain quite scarce. For example, a search conducted July 10, 2004, for the term “neuroethics” in the online archives of the *Journal of American Medical Association* (JAMA) retrieved no items. Nonetheless, experimental scientific literature (Roco and Bainbridge, 2003; Roco and Montemagno, 2004), coupled with forward-looking publications on the ethics and policy of cognitive enhancement (McGaugh, 1991; Caplan, 2003; Wolpe, 2003; Boire,

2004a, 2004b; Farah *et al.*, 2004; Khushf, 2004; Lynch, 2004; Sententia, 2004), along with topically-driven popular press and professional reviews (e.g., Krieger, 2002; Russo, 2002; Arnst, 2003; Breithaupt and Weigmann, 2004; Johnson, 2004; Morris, 2004), point to increased scientific viability and a growing awareness among some regarding the impact of neuro-technological advances with a potential to impact human cognition. Accordingly, a focus on memory drugs merits further attention.

At the NBIC Convergence 2004 Conference held in New York, several speakers addressed the cultural, legal, ethical, and disciplinary challenges and opportunities related to human performance enhancement generally, and neurocognitive enhancement specifically. In addition, in two recent articles, Martha Farah and Paul Root Wolpe, together with colleagues, outlined a number of the ethical implications of new neuroscience technologies increasingly capable of monitoring and manipulating and augmenting mental processes (Farah and Wolpe, 2004; Farah *et al.*, 2004). Although some concern is raised by brain imaging and monitoring technologies re-purposed for nonmedical uses, (Farah and Wolpe, 2004; Sententia, 2001), the emerging debate over pharmacological memory improvers and other pharmacological interventions draws on trends in the industry that are more likely to impact society in the very near future (Boire, 2004a). A first order of concern identified by Farah and Wolpe (2004) is simply safety. This is an area in which, although there may be differences of opinion as to what “safety” means from a personal cost/benefit analysis (as in a difference between risk and danger), most people would agree that memory drugs must be safe. As related to memory drugs, the second order of concerns the researchers identify is the neurophilosophical Pandora’s box of human identity – questions of assessing how our thinking relates to who we are and what we do or are capable of doing, of how neuropharmaceutical interventions in the brain’s processes (and our growing neuroscience-based knowledge) impact our conceptions of ourselves. These questions are at the forefront of a debate that is both ontologically and epistemologically complex. In his *Confessions*, Saint Augustine (354–430 AD) famously raised the issue as “*quaestio mihi factus sum*,” or “a question have I become for myself.” However, in some respects, assuming safety and efficacy, the prospects of the widespread availability of memory drugs comes down to the question: Who wouldn’t want a better memory?

### **Memory Medicines**

In October 2003, the U.S. Food and Drug Administration (FDA) approved the drug memantine (Namenda) for the treatment of moderate to severe Alzheimer’s Disease (FDA, 2003). Alzheimer’s Disease is a devastating condition affecting memory, judgment, and the ability to reason.

Questions of what causes this disease are wrapped in controversy (de la Torre, 2004), and Nobel Prize-winning scientist Eric Kandel has called current Alzheimer's treatments "an act of despair" because of their lack of ability to perform early intervention in cognitive decline (Arnst, 2003). Nonetheless, clinical testing of memantine has proven it to be effective not only in relieving the general symptoms of Alzheimer's Disease, but also in lessening memory loss associated with the disease (Reisberg *et al.*, 2003). Age-associated cognitive decline, although not specifically related to an identifiable disease in the elderly, is garnering attention as a potential market of 180 million older adults (50 percent of all people over the age of 65 years) for potential drug intervention.<sup>1</sup> Some research indicates that active and socially integrated lifestyles in later life help protect against dementia (Fotuhi, 2002; Fratiglioni *et al.*, 2004). Nonetheless, should safe and effective drug compounds be developed, prophylactic use of memory drugs might be widely used to forestall memory-related decline (Rubin, 2004; Sandeep *et al.*, 2004), just as mood improvement drugs (selective serotonin reuptake inhibitors) are increasingly prescribed for people who have no recognized illness (Kramer, 1993; Farah and Wolpe, 2004). Better drugs to enhance or improve cognition – beyond merely forestalling memory loss – are a logical and likely outgrowth on the horizon of the neuropharmaceutical industry.

Memory drugs promise to be an important, multi-billion dollar industry as a host of companies work feverishly to bring such drugs to market. The brokerage firm A. G. Edwards estimates that the current global market for memory medicines is already 10 billion dollars, and at least 60 pharmaceutical and biotechnology companies around the world are working on new memory drug compounds, with approximately 40 experimental drugs already in human trials (Arnst, 2003). According to *Business Week*, the leading drug contenders include SGS742 (Saegis Pharmaceuticals), CX516 (Cortex Pharmaceuticals), Mem 1414 (Memory Pharmaceuticals); Aricept (Pfizer), and memantine (Merz/Forest Labs). Yet other competitors are rapidly coming on the scene, as with Helicon Therapeutics's imminent human trials of a novel compound (Scott *et al.*, 2002; Tully *et al.*, 2003; Rubin, 2004). Discoveries in neurological structure and brain function enabled by increasingly precise techniques continue to impact what is conceivable in terms of pharmacological interventions in the brain (Fields, 2004). Even though memory enhancers are ostensibly for impaired or at-risk patients, assuming current trends continue and popular press coverage of them grows, people will undoubtedly want to use such drugs for "non-medical" purposes for the benefit of improving their memory. One 76-year-old patient involved in a clinical trial with Cortex Pharmaceuticals's compound CX516, who "lobbied hard" to enter a clinical trial for people

---

<sup>1</sup> [www.memorypharma.com/market\\_aacd.html](http://www.memorypharma.com/market_aacd.html)

suffering from mild cognitive impairment, speaks well to the foreseeable trends of generalized application: “At the start of the trial, I could remember less than five words out of a list of 20. By the second week, I could get 14 out of 20. There was a very, very appreciable enhancement.” Following this clinical study, and missing the clinical dose of CX516, this individual further remarks: “I’ve been thinking of some other way to get [CX516], and I don’t give a damn if it’s legal or illegal” (quoted in Arnst, 2003). Sention, a pharmaceutical development company focused on the “discovery and development of drugs to treat memory impairment and other central nervous disorders” estimates that 80 percent of people over the age of 30 years complain of some degree of memory loss (MPM Capital, 2002). In a recent newspaper article, Sention’s CEO Randall Carpenter said: “People are already using a wide range of medical drugs to improve their own performance [alluding to Viagra]. It’s almost impossible to stop people if they want to do that” (Rubin, 2004).

If U.S. drug policy is any model, efforts to halt personal use simply based on legal bans are not viable social policy (Ryoko *et al.*, 2003; Gunja *et al.*, 2004). For example, according to the 2002 National Survey on Drug Use and Health, 35.1 million Americans aged 12 years or over (14.9% of the U.S. population aged 12 years and over) used an illicit drug during the preceding year. Furthermore, the diversion of legal stimulants is on the rise (U.S. National Institute on Drug Abuse [NIDA], 2001; McVay, 2004). A case in point: on college campuses prescription attention drugs like Provigil (modafinil), Ritalin (methamphetamine), or Adderol (Dextroamphetamine) are being used by university students cramming for exams (Babcock and Byrne, 2000; Farah *et al.*, 2004). In examining the non-medical use of prescription drugs, NIDA cites, for example, the use of methylphenidate (Ritalin) among high school seniors at an increased rate from an annual prevalence (use of the drug within the preceding year) of 0.1 percent in 1992 to an annual prevalence of 2.8 percent in 1997. NIDA also documents a rise in college students’ nonmedical use of pain relievers such as oxycodone (Percodan) and hydrocodone (Vicodin) (NIDA, 2001). Nicotine has been shown to favorably improve memory-related tasks for habituated users of this legal substance (Ernst *et al.*, 2001), and the benefits of caffeine are widely acknowledged and incorporated into work-related culture in the United States and elsewhere. Interestingly, although the ethics of sports doping tends to focus on improving physical skill (muscle enhancers, steroids, human growth hormone; Shapiro, 1991), a recent barrage of news coverage has focused on the athletic use of modafinil, a mental stimulant originally approved by the U.S. Food and Drug Administration to treat sleepiness associated with narcolepsy but more recently extended to shift-work sleep disorder, which is

fatigue among shift workers who suffer from circadian-rhythm disruption (Turner *et al.*, 2003; Loyd, 2004).<sup>1</sup>

James Canton of the Institute for Global Futures projects the emergence of a worldwide market for human performance enhancement (Canton, 2004), and with it, of course, neurocognitive enhancement. Drawing on social and economic trends emerging from current debates over stem cell usage and therapeutic cloning, and on consumer demand for perceived lifestyle benefits from fertility science, plastic surgery, and drugs like Prozac and Viagra, Canton anticipates the mounting trend: In a national interview-based study performed by the Institute for Global Futures and Roper ASW of 1300 young Americans aged 16–24 years, a significant majority of those polled responded that they would be interested in enhancing their intelligence and performance, with more than 50% favoring drugs to do so (Canton, 2003, 2004).

Assuming that these socio-economic trends continue across age groups and cultures, it is only a matter of time before even more cognition-improving drugs will be widely available and widely used to match people's desires for cognitive boosters.

### **Forgetting Drugs**

Conversely, what if people want to forget? Although most industry interest in memory drugs is focused on those that boost recall or memory retention, there are some people who suffer from painful memories and who might benefit from pharmaceuticals that lessen their ability to remember. At any given time, approximately 13 million Americans suffer from post-traumatic stress disorder (PTSD); for these people, the prospects of a medicine that will dim, or perhaps even erase, torturous memories are enthusiastically anticipated (Boire, 2004b). Propranolol, a drug commonly prescribed to treat high blood pressure and heart disease, has been used to dull memories in the treatment of PTSD (Pittman *et al.*, 2002). Propranolol works by blocking the body's adrenalin response. Studies have shown that if taken within 6 hours of a traumatic event, beta-blockers like propranolol, which suppress the action of epinephrine, can significantly reduce recall of that event and may even be able to reduce the emotional impact of retrieved painful memories from childhood (McGaugh *et al.*, 1996; McGaugh, 2002; Eisenberg *et al.*, 2003). For this reason, efforts to forestall PTSD may soon mean offering a drug such as propranolol to victims of violent crimes or serious accidents (Goodman, 2002; Layton and Krikorian, 2002). Propranolol and similar drugs may also be used to pre-dose emergency responders to plane crashes or other gruesome accident scenes. Versed (midazolam

---

<sup>1</sup> [www.mongabay.net/medications/drug\\_news/Modafinil.html](http://www.mongabay.net/medications/drug_news/Modafinil.html)

hydrochloride), manufactured by Hoffman-LaRoche, Inc., is a benzodiazepine used for conscious sedation before surgery to relieve anxiety or impair memory. The prophylactic applications described here raise issues of informed consent in instances in which people are being administered memory-attenuating drugs. But more generally, questions of individuals' rights to manage their own memories come to the foreground where "nontherapeutic" uses of memory-dimming drugs might be a desirable outcome (Boire, 2004b).

Recent films reflect a continued fascination in popular culture with the imagined possibilities of computer-assisted memory erasure. *Paycheck* (Paramount Pictures, 2003; starring Ben Affleck and Uma Thurman) raises questions over the voluntary and coerced use of memory-erasing technologies. *Eternal Sunshine on the Spotless Mind* (Focus Features 2004; starring Jim Carrey and Kate Winslet) presents a tongue-in-cheek "treatment" using brain scan-and-delete technology that the doctor of the fictitious company, Lacuna Inc., admits in passing, is quite literally brain damage. Yet aside from the fictional depictions of memory erasure, existing drugs like Propranolol and those to come raise broader, more pressing, and far-reaching societal issues. For if the recollection of certain experiences may plague each of us, and if the psychopharmacological means to alleviate these are made safely available, the question will be whether people have a right to use drugs to intentionally dim their own memories. This is one of the central topics addressed by the President's Council on Bioethics in their 2003 report, *Beyond Therapy: Biotechnology and the Pursuit of Happiness*. Chapter five of the report, entitled "Happy Souls" opens:

Who has not wanted to escape the clutches of oppressive and punishing memories? Or to calm the burdensome feelings of anxiety, disappointment, and regret? Or to achieve a psychic state of pure and undivided pleasure and joy? The satisfaction of such desires seems inseparable from our happiness, which we pursue by right and with passion. (President's Council on Bioethics, 2003: 205)

Soundly, the council points to human desires as drivers in an elusive pursuit of happiness – a pursuit that is integral to the individual rights proclaimed in the American Declaration of Independence. The council goes on to assert in this chapter that the pursuit of happiness is connected to memory, commenting that memory is "central to human flourishing," to a sense of narrative "self" that is "crucial for preserving the 'myness' of any happiness that comes our way" (President's Council on Bioethics, 2003: 215). And yet, I would respectfully submit that the council oversteps its role as a public advisory body in prescribing the parameters on just what that a pursuit of happiness should be, by imposing a hierarchy of values

(permanence, linearity, work) on the content of memory, and by setting down a prescriptive valuation of individual happiness, glossed as the freedom to pursue it. In a gesture towards complexity, the report notes that pursuit “is here properly ambiguous, encompassing both the quest to find happiness and the enjoyment of happiness once found (as in ‘my favorite pursuits’)” (President’s Council on Bioethics, 2003: 205). This acknowledgment of ambiguity falls short, however, as the ensuing discussion of happiness makes clear the council’s valuation of certain pursuits over others.

The council offers the perspective that memory is cumulative and is therefore a reliable measure of one’s identity. In addition, the council posits that it is memory of this “self” that acts as a reliable barometer of human happiness (“[I]f enfeebled memory can cripple identity, selectively altered memory can distort it. Changing the content of our memories or altering their emotional tonalities . . . could subtly reshape who we are, at least to ourselves” [President’s Council on Bioethics, 2003: 212]). Strong emotions may make for strong memories, but who is to say which ones we should keep? As most people are intuitively aware, memory is an unreliable referencing point, just as historical memory is more about the stories we tell ourselves, than about what actually “happened” (White, 1987). Furthermore, recent research in memory and recall shows, that a monolithic, reliable, factual memory is a fiction at best (McGaugh, 1991; Shacter, 2001). The President’s Council passes value judgments on what constitutes worthy sentiments, passions, and virtues and condemns what they call shallow and facetious happiness, calling for a “rightly understood” happiness (President’s Council on Bioethics, 2003: 268-270). Yet it is because what we do (or do not) remember is such a very personal and private (and malleable) matter, and because we live in a democracy that asserts the individual’s choice in a pursuit of happiness as an inalienable right, that it does not make sense to appeal to one (Aristotelian) valuation of what qualifies as “good” memory or “good” happiness.

### **Shifting Parameters: Postmodern Medicine and Memory**

In 1948, the inaugural World Health Organization (WHO) defined health as, “a state of complete physical, mental and social well-being and not merely the absence of disease or infirmity.”<sup>1</sup> This WHO definition has not been amended since 1948, and its crafters could hardly have imagined the extent to which medical science is increasingly involved in the non-therapeutic improvement of human physical and mental capacities. Conventionally, “medicine” is defined first as a substance or preparation used

---

<sup>1</sup> [w3.who.sea.org/aboutsearo/const.htm](http://w3.who.sea.org/aboutsearo/const.htm)

to treat disease, and second as the science of disease prevention, diagnosis, alleviation, and cure.

The Hippocratic oath, generally attributed to the “father” of Western medicine, Hippocrates, lays down the ethical duties of a physician. The physician’s role in attending to the needs of his or her patients is intrinsic to the ancient Hippocratic oath, and is considered the “immutable bedrock of medical ethics” (Pellegrino, 1995). However, the practice of formally reciting the oath as a foundation for a professional code is a fairly recent phenomena dating from the 19th century (Baker *et al.*, 1999; Graham, 2000). Since then, it has been increasingly used in medical schools but has also been increasingly modified to reflect changes in the scope, the purpose, and consequently the ethics of medicine in order to incorporate and accommodate shifts not only in medical understanding but also in social values (Shortell *et al.*, 1998; Graham, 2000). In a 1993 study, it was found that some version of the oath was administered in 98% of allopathic and osteopathic schools of medicine polled throughout the United States and Canada (Orr *et al.*, 1997). Like the oath itself, “medical necessity” in today’s medicine is changing, and most bio- and neuroethicists, as well as physicians, accept that the line between therapeutic and enhancement interventions in physical traits or cognitive abilities is blurry at best (Parens, 1998; Marcus, 2002; Chatterjee, 2004).

As any number of NBIC advances intimate, “medicine,” as both a pharmaceutical preparation and a field of human science, is poised to do much more than overcome or prevent illness. Converging knowledge in a number of crucial disciplines – biology, chemistry, pharmacology, computer engineering (prosthetics, interfacing, and imaging), and, eventually, nanomedicine (Freitas, 1999, 2003) – indicate a trend towards the direct manipulation of bodies and brains for reasons that exceed therapeutic need. Because modern medical technologies are continually refining and accelerating what doctors can do for patients on their behalf, the question of what they should do is becoming increasingly strained.

If there were a drug available that could safely increase your “normal” recall or retention, would you ask your doctor for it? Memory, retention, and recall are bound to an epistemological (and existentialist) tautology – what each of us knows about ourselves is in some respect tied to what we can remember – but exactly who is to say what is worth remembering or forgetting? For some, memory in school and work performance equate with a certain “success” as measured in high test scores or professional advancement – something that typically provides economic and, to some minds, important social benefits. For others, however, high marks on standardized testing and making the promotion are not important goals or indicators of human value.



What I call postmodern medicine allows for a multiplicity of views of medicine as a social practice. Postmodern medicine calls for a medical recognition that the cultural, religious, and semantic differences we live by are the vibrancy of a healthy global human ecology. Postmodern medicine is medicine in which the terms of conventional health care, predicated on therapeutic role of the physician operating in the “best” interest of the patient have been altered, but not overcome, by capitalist drivers. Consumer desire, predicated on increasing and more informed choices in health care, at play in a feedback loop with company-driven or health care industry-driven economic flows adds to the diversity of views on medicine. The specific shifts I have in mind involve the public’s role in the changing patient–physician relation, the changing economic climate, and a changing set of professional standards in medical practice; what Friedson calls, “the crippling of the traditional practice of medicine” (in Baker *et al.*, 1999). I would assert that, with caveats on the economics of distributive health care and privacy concerns, today’s conditions hold the promise of improved medical practice.

Postmodernity is marked by a relinquishment of meta-narratives, by an acceptance that monolithic cultural, disciplinary, or national histories do not tell the whole story (Lyotard, 1984; White, 1987). Knowledge in science, in technology, and in the arts is scrutinized as doctrine rather than as final words on the human condition, and medicine has likewise been significantly impacted by additional viewpoints on novel capabilities and changing social trends.

Postmodern medicine, then, may involve treating patients who are not necessarily ill, or at least not in ways conventionally defined by traditional medicine. In terms of human memory, this might mean preventative or enhancement measures to stave off the potential risks of cognitive decline, or it might mean “boosts” to cognitive capability through drugs (Caplan, 2003; Farah and Wolpe, 2004). Postmodern medicine allows for greater choice, as we are increasingly able to reconstruct or restructure the human body or the human brain for enhanced ability, productivity, or pleasure. Postmodern medicine capitalizes on perceived benefits or social advantage and on a challenge of self-improvement (self-modification, self-medication, and self-modulation). In brutal economic terms, postmodern medicine will likely initially cater to individuals with money. As with any technology, medical technologies, and with them neuropharmaceutical advances, are imbedded in a socio-economic matrix, which in an increasing number of countries across the globe means a capitalist paradigm (Castells, 1996; Canton, 2004; Lynch, 2004). This is not to disparage or ignore the real crisis of global (and national) health care but, rather, to acknowledge the working conditions under which we must strive to overcome such real inequities in pursuit of the

United Nations Millennium Development Goals for global health and wellbeing.<sup>1</sup>

### *Postmodern Memory*

If one accepts that the variables of medicine are changing as a result of advances in science and technology, shifts in economic flows, and changes in patient/consumer-to-doctor relationships, it may also be useful to consider how “memory” as a concept might differ now from in previous generations. It is beyond the scope of this chapter to address the myriad ways in which information technology has impacted various disciplines, cultures, and social practices. However, I note that the externalization of information and a simultaneous spread of integrated information systems or virtual methods for the retrieval and dissemination of data that have arisen from electronic and digital technologies may be changing not only how we think about information and knowledge but also how we think about memory. For example, hypertextual linking on Web pages adds to how we can “move” through ideas, changing the linear experience of reading, and consequently of what and how we recall. Whimsically, Larry Page, co-founder of the Google Internet search engine, indulged his own seduction to the prospects of a future brain-machine interface as a solution to human memory retrieval problems: “On the more exciting front, you can imagine your brain being augmented by Google. For example you think about something and your cell phone could whisper the answer into your ear” (cited in Orłowski, 2004).

### *Prosthetic Memory*

Alison Landsberg (1995, 2004) calls “prosthetic memory” those memories not strictly derived from one’s lived experience but vicariously drawn into a person’s mind and woven into the fabric of his or her life; for example, mass cultural experiences like seeing a film at the cinema or visiting a “living history” museum. Prosthetic memories become a part of one’s personal experiential archive, informing a sense of “self” – one’s subjectivity – one’s propensity to act or not in accordance with what one remembers. Moral philosophy, or the ethics of “right” and “wrong” behavior, is inextricably bound to conceptions of what and how we view our human condition. Landsberg echoes social theorist Hannah Arendt’s mid-20th-century query into *The Human Condition* (1958). The human condition, writes Arendt, is characterized by an incorporation of thought into action, but it is also mediated by technology:

---

<sup>1</sup> [www.un.org/millenniumgoals/](http://www.un.org/millenniumgoals/); cf. [www.gapminder.org](http://www.gapminder.org).

Whatever touches or enters into a sustained relationship with human life immediately assumes the character of a condition of human existence. This is why men, no matter what they do, are always conditioned beings. Whatever enters the human world of its own accord or is drawn into it by human effort becomes part of the human condition. (Arendt, 1958: 9)

Today's technologies and the questions they raise are more groping, more comprehensive of the human condition than ever before. In keeping with today's postmodern conditions for humanity, the objects, tools, and technologies we use are often not only prosthetic but remote, or virtual. For example, computer imaging tools are used to reverse engineer not only planes but to fly them, and medical scanning tools aid in diagnosis and in guiding surgery. To the panoply of such virtual tools, we can now add pharmaceutical prosthetics able to make, remake, and assist in retrieving human memories.

Princeton moral philosopher Joshua Greene used functional magnetic resonance imaging brain imaging and medical scanning devices to reanimate questions of human behavior and moral decision making through the study of cerebral functioning and neurochemistry. By pointing to the complex interplay of an individual's neurochemical-electrical brain states involved in social (moral) behavior, Greene brought together cognitive neuroscience and long-standing philosophical questions regarding human moral behavior. He examined the neural circuits activated during the process of making difficult moral decisions and the differences between "rational" and "emotional" triggers in ethical thinking (Greene *et al.*, 2001).

Memories are, in a sense, always virtual, as we poetically conjure ourselves, our beliefs and ambitions, from what Shakespeare called the "stuff of dreams." Prosthetic memories, as Landsberg describes them then, can be virtual experiences, but they are none the less "real" for it. The distinction between "real" and "implanted" memories, like the distinction between "natural" humans and the "unnatural" technologies we assimilate, is in some respects arbitrary.

Still, allowing the discussion I have briefly outlined above, it may be that cultural shifts in how we relate to history in general, and our own stories or memories, are opening up the possibility of more multiplicitous, more prosthetic kinds of knowledge and remembering that may carry ethical social advantages. If Landsberg is right, lived differences, (and even lived simulated differences) could have benefits that traditional moral reasoning does not. Landsberg argues that the political potential of prosthetic memory is its ability to enable ethical thinking. "Thinking ethically means thinking beyond the immediacy of one's own wants and desires. Prosthetic memory teaches by fostering empathy" (Landsberg, 2004: 149).

Empathy is historically distinct from sympathy. Landsberg argues that whereas sympathy is a feeling that arises out of identification, empathy stems from imagining difference. On the one hand, sympathy grew out of an ethics of similarity – looking for sameness between the sympathizer and his or her object grounded in emotive assumptions about shared experience. As such, sympathy entails the projection of one’s own feelings (one’s own happiness) on another. An extensive discussion in post-colonial social theory as well as gender theory based on the concept of “otherness” speaks to this important distinction (Guha and Spivak, 1988; Bhabha, 1994). On the other hand, empathy, a relatively recent word that first appeared in English in 1904, is distinctive in that even in its first usages, empathy, unlike sympathy, carried “a cognitive component” (Landsberg, 2004: 149). I am aware that sympathy necessarily carries a cognitive component in human processing. An interesting neurocognitive behavioral study would be to study these semantic distinctions as they operate in the brain as a query of sympathy and empathy as two kinds of emotive moral reasoning.

### **Remembering Freedom of Thought**

Freedom of thought is recognized in United States and international law, but it is not articulated very well. As recently as 2002, the U.S. Supreme Court noted, “[t]he right to think is the beginning of freedom, and speech must be protected from the government because speech is the beginning of thought” (*Ashcroft v. Free Speech Coalition* 533 U.S. 234 2002). Following World War II, the United Nations codified freedom of thought in its Universal Declaration of Human Rights (1948), but largely in the context of free religious belief. Article 18 states: “Everyone has the right to freedom of thought, conscience and religion; this right includes freedom to change his religion or belief, and freedom, either alone or in community with others and in public or private, to manifest his religion or belief in teaching, practice, worship and observance.” In 1937, when U.S. Supreme Court Justice Benjamin Cardozo declared that freedom of thought is the “matrix, the indispensable condition of nearly every other freedom,”<sup>1</sup> the simple transistor had not yet been invented, and antidepressants and the Information Age were 40–50 years away. More recently, in 1995, a United Nations report on Ethics and Neuroscience called attention to how new scientific and technological developments are impacting the brain – a human organ the report recognized as “the organic core of the person, the agent of his freedom but also of the individual and social constraints which restrict that freedom” (Vincent, 1995). And yet, in spite of recognition of the human brain’s centrality to freedom, the articulation of how to protect this very intimate and important

---

<sup>1</sup> *Palko v. Connecticut*, 302 U.S. 319, 326-27 (1937).

freedom to think that we all enjoy is, in a neurocognitive technological age, largely lacking.

Change in this world stems from thought put into action; from people imagining and implementing what they can do. In supporting scientific and technological development, the application and regulation of neurotechnologies can be channeled by a renewed allegiance to the fundamental human right to freedom of thought. Three guiding principles that might help to frame public policy of human freedom at the intersection of neurotechnologies are privacy, autonomy, and choice:

- **Privacy:** What and how you think should be private unless you choose to share it. The use of technologies such as brain imaging and scanning must remain consensual, and any information so revealed should remain confidential. The right to privacy must be found to encompass the inner domain of thought.
- **Autonomy:** Self-determination over one's own cognition is central to free will. School boards, for example, should not be permitted to condition a child's right to public education on taking a psychoactive drug such as Ritalin. Decisions concerning whether or how to change a person's thought processes must remain the province of the individual as opposed to that of government or industry.
- **Choice:** The capabilities of the human mind should not be limited. Freedom of thought must include the right to choose. A competent adult should be allowed to make choices concerning his or her own use of medicines and other neurotechnologies.

### **Concluding Remarks on Memory: Who is to Decide?**

In an age of neurocognitive drugs to enhance memory or attenuate it, who will decide what we can or can not remember? Who is to say what we may or may not actively seek to forget? William Hurlbut, a member of the President's Council on Bioethics, has eloquently described what he sees as the human condition:

The pattern of our personality is like a Persian rug. It is built one knot at a time, each woven into the others . . . there's a continuity to self, a sense that who we are is based upon solid, reliable experience. We build our whole interpretation and understanding of the world based upon that experience or on the accuracy of our memories. If you disrupt those memories, remove continuity, what you have is an erosion of personhood. (quoted in Lafée, 2004)

Whereas Hurlbut, and others (Fukuyama, 2002; Kass, 2003) who share his concern for humanity in a next dance with memory manipulation rightly see the issues as hinging on identity, on self-interpretation and experiential validity for social viability, I think they mistake sympathy for their fellow humans at the expense of empathy for others' differences. If each person is a unique composite of memories and experiences, no matter what those experiences are, it may be that we need to protect the reserves of human potential by allowing for an inclusive, rather than prescriptive, repertoire of individual and collective self-expression. In working through the tapestry of our lives, it may be that some aim for a Persian rug, while others look to expressionist or abstract art for their patterns. In one wing of an imagined museum, we might find the resplendence of rugs from the Middle East, in another, Jackson Pollack's 1950 oil-on-canvas painting, *Convergence*. In such a museum of humanity, I would like to maintain that diversity of thought is our collective heritage and our collective promise – something to be protected and remembered.

## References

- Arendt, H. 1958. *The Human Condition*. Chicago: University of Chicago Press [1998].
- Arnst, C. 2003. I can't remember: Drugs to stave off age-induced memory impairment. *Business Week* (1 September).
- Babcock, Q., and T. Byrne. 2000. Student perceptions of methylphenidate abuse at a public liberal arts college. *Journal of American College Health* 49: 143–145.
- Baker, R. B., A. Caplan, L. L. Emanuel, and S. R. Latham (eds.). 1999. *The American Medical Ethics Revolution: How the AMA's Code of Ethics Has Transformed Physicians' Relationships to Patients, Professionals, and Society*. Baltimore: John Hopkins University Press.
- Bhabha, H. 1994. *The Location of Culture*. New York: Routledge.
- Boire, R. G. 2004a. *Pharmacotherapy and the Future of the Drug War*. Davis, Calif.: Center for Cognitive Liberty and Ethics. [www.cognitiveliberty.org/issues/pharmacotherapy.html](http://www.cognitiveliberty.org/issues/pharmacotherapy.html).
- Boire, R. G. 2004b. Cognitive liberty in the age of memory management drugs. *California Daily Journal* (January).
- Breithaupt, H., and K. Weigmann. 2004. Manipulating your mind: What will science discover about our brains, and how are we going to deal with it? *European Molecular Biology Organization* 5(3): 230–232.
- Canton, J. 2003. *America's Youth Looks to the Future*. San Francisco: Institute for Global Futures. [www.futureguru.com/docs/FinalSurveyLight.pdf](http://www.futureguru.com/docs/FinalSurveyLight.pdf).
- Canton, J. 2004. Designing the future: NBIC technologies and human performance enhancement. The co-evolution of human potential and converging technologies. Pp. 186–198 in M. C. Roco and C. D. Montemagno (eds.), *The Coevolution of Human Potential and Converging Technologies*. New York: New York Academy of Sciences.

- Caplan, A. L. 2003. Is better best? A noted ethicist argues in favor of brain enhancement. *Scientific American* 289 (September): 104–105.
- Castells, M. 1996. *The Rise of the Network Society*. Malden, Mass.: Blackwell.
- Chatterjee, A. 2004. Cosmetic neurology: The controversy over enhancing movement, mentation, and mood. *Neurology* 63 (September): 968–974.
- de la Torre, J. 2004. Is Alzheimer's disease a neurodegenerative or a vascular disorder? Data, dogma, and dialectics. *The Lancet Neurology* 3(3): 184–190.
- Eisenberg, M., T. Kobil, D. E. Berman, and Y. Dudai. 2003. Stability of retrieved memory: Inverse correlation with trace dominance. *Science* 301(5636): 1102–1104.
- Ernst, M., J. A. Matochik, S. J. Heishman, J. D. Van Horn, P. H. Jons, J. E. Henningfield, and E. D. London. 2001. Effect of nicotine on brain activation during performance of a working memory task. *Proceedings of the National Academy of Sciences USA* 98: 4728–4733.
- Farah, M. J. 2002. Emerging ethical issues in neuroscience. *Nature Neuroscience* 5: 1123–1129.
- Farah, M. J., J. Illes, R. Cook-Deegan, H. Gardner, E. Kandel, P. King, E. Parens, B. Sahakian, and P. R. Wolpe. 2004. Neurocognitive enhancement: What can we do and what should we do? *Nature Reviews Neuroscience* 5(5): 421–425.
- Farah, M. J. and P. R. Wolpe. 2004. Monitoring and manipulating brain function: New neuroscience technologies and their ethical implications. *Hastings Center Report* 34(3): 35–45.
- Fields, D. 2004. The other half of the brain. *Scientific American* 290(4): 27–33.
- Fotuhi, M. 2002. *The Memory Cure: How to Protect Your Brain against Memory Loss and Alzheimer's Disease*. New York: McGraw-Hill.
- Fratiglioni, L., S. Paillard-Borg, and B. Winblad. 2004. An active and socially integrated lifestyle in late life might protect against dementia. *The Lancet Neurology* 3(6): 343–351.
- Freitas, R. A. 1999. *Nanomedicine Volume I: Basic capabilities*. Georgetown, Texas: Landes Bioscience.
- Freitas, R. A. 2003. *Nanomedicine Volume IIA: Biocompatibility*. Georgetown, Texas: Landes Bioscience.
- Fukuyama, F. 2002. *Our Posthuman Future: Consequences of the Biotechnology Revolution*. New York: Farrar, Straus, and Giroux.
- Goodman, E. 2002. Matter over mind? *Washington Post* (16 November).
- Gerlai, R. 2003. Memory enhancement: The progress and our fears. *Genes Brain Behavior* 2: 187–188; discussion 189–190.
- Graham, D. 2000. Revisiting Hippocrates: Does an oath really matter? *Journal of the American Medical Association* 284(22): 2841–2842.
- Greely, H. T. 2004. Neuroethics: The neuroscience revolution, ethics, and the law. Markkula Center for Applied Ethics, Santa Clara University. Regan Lecture (20 April).
- Greene, J. D., R. Brian Sommerville, L. E. Nystrom, J. M. Darley, and J. D. Cohen 2001. An fMRI investigation of emotional engagement in moral judgement. *Science* 293: 2105–2108.
- Grill, W. M. and R.F. Kirsch. 2000. Neuroprosthetic applications of electrical stimulation. *Assistive Technology* 12: 6–20.

- Guha, R., and G. C. Spivak (eds.). 1988. *Selected Subaltern Studies*. New York: Oxford University Press.
- Gunja, F., A. Cox, M. Rosenbaum, and J. Appel. 2004. Making sense of student drug testing. American Civil Liberties Union, Drug Policy Alliance. [www.drugtestingfails.org/pdf/drug\\_testing\\_booklet.pdf](http://www.drugtestingfails.org/pdf/drug_testing_booklet.pdf).
- Illes, J., M. P. Kirschen, and J. D. E. Gabrieli. 2003. From Neuroimaging to Neuroethics. *Nature Neuroscience* 6 (3): 205.
- Johnson, S. 2004. *Mind Wide Open: Your Brain and the Neuroscience of Everyday Life*. New York: Scribner.
- Juengst, E. T. 1998. Pp. 29–47 in E. Parens (ed.), *Enhancing Human Traits: Ethical and Social Implications*. Washington, D.C.: Georgetown University Press.
- Kass, L. R. 2002. *Life, Liberty and the Defense of Dignity: The Challenge for Bioethics*. San Francisco: Encounter Books.
- Kass, L. R. 2003. Beyond Therapy: Biotechnology and the Pursuit of Human Improvement Staff Working Paper. [www.bioethics.gov/background/kasspaper.html](http://www.bioethics.gov/background/kasspaper.html).
- Khushf, G. 2004. Systems theory and the ethics of human enhancement. The co-evolution of human potential and converging technologies. Pp. 124–149 in M. C. Roco and C. D. Montemagno (eds.), *The Coevolution of Human Potential and Converging Technologies*. New York: New York Academy of Sciences.
- Kramer, P. D. 1993. *Listening to Prozac*. New York: Viking.
- Krieger, L. M. 2002. Ethics of mind and manipulation. *San Jose Mercury News* (21 May).
- LaFee, S. 2004. Blanks for the memories. *San Diego Union Tribune* (11 February).
- Landsberg, A. 1995. Prosthetic memory: Total Recall and Blade Runner. Pp. 175–189 in M. Featherstone and R. Burrows (eds.), *Cyberspace/Cyberbodies/Cyberpunk: Cultures of Technological Embodiment*. London: Sage.
- Landsberg, A. 2004. *Prosthetic Memory: The Transformation of American Remembrance in the Age of Mass Culture*. New York: Columbia University Press.
- Layton, B., and R. Krikorian. 2002. Memory mechanisms in Posttraumatic Stress Disorder. *Journal of Neuropsychiatry and Clinical Neurosciences* 14: 254–261.
- Loyd, L. 2004. Cephalon to move its Philadelphia-area executive, administrative offices. *The Philadelphia Inquirer* (26 March).
- Lynch, G. 2002. Memory enhancement: The search for mechanism-based drugs. *Nature Neuroscience* 5: 1035–1038.
- Lynch, Z. 2004. Neurotechnology and society. Pp. 229–233 in M. C. Roco and C. D. Montemagno (eds.), *The Coevolution of Human Potential and Converging Technologies*. New York: New York Academy of Sciences.
- Lyotard, J. F. 1984. *The Postmodern Condition: A Report on Knowledge*. Minneapolis: University of Minnesota Press.
- Marcus, S. J. (ed.). 2002. *Neuroethics: Mapping the Field*. New York: Dana Press.
- McGaugh, J. L. 1991. Enhancing cognitive performance. *Southern California Law Review* 65(1): 383–395.
- McGaugh, J. L. 2002. Memory consolidation and the amygdala: A system perspective. *Trends in Neuroscience*. 25(9): 456–461.



- McGaugh, J. L., L. Cahill, and B. Roozendaal. 1996. Involvement of the amygdala in memory storage: Interaction with other brain systems. *Proceedings of the National Academy of Sciences* 93: 13508–13514.
- McVay, D.A. (ed.). 2004. *Drug War Facts: Common Sense for Drug Policy*. Rockville, Maryland: Substance Abuse and Mental Health Services Administration, U.S. Department of Health and Human Services. [www.drugwarfacts.org](http://www.drugwarfacts.org).
- Morris, K. 2004. New wave neurotechnology: Small-scale makes big promises. *The Lancet Neurology* 3(4): 202.
- MPM Capital. 2002. MPM Capital leads \$13mm financing of Sention, a company conducting human trials with memory drug. Press Release (12 February). [www.mpmcapital.com/flash/news/020212.html](http://www.mpmcapital.com/flash/news/020212.html).
- Orlowski, A. 2004. Google founder dreams of Google implant in your brain. *The Register*. [www.theregister.co.uk/2004/03/03/google\\_founder\\_dreams\\_of\\_google](http://www.theregister.co.uk/2004/03/03/google_founder_dreams_of_google).
- Orr, R. D., N. Pang, E. D. Pellegrino, and M. Siegler. 1997. Use of the Hippocratic oath: A review of twentieth century practices and a content analysis of oaths administered in medical schools in the US and Canada in 1993. *Journal of Clinical Ethics* 8: 377–388.
- Parens, E. (ed.). 1998. *Enhancing Human Traits: Ethical and Social Implications*. Washington, D.C.: Georgetown University Press.
- Pellegrino, E. D. 1995. Interests, obligations, and justice: Some notes toward an ethic of managed care. *Journal of Clinical Ethics* 6: 312–317.
- Pittman, R. K., K. M. Sanders, R. M. Zusman, A. R. Healy, F. Cheema, and N. B. Lasko. 2002. Pilot study of secondary prevention of posttraumatic stress disorder with propranolol. *Biological Psychiatry* 15: 189–192.
- President's Council on Bioethics. 2003. *Beyond Therapy: Biotechnology and the Pursuit of Happiness*. New York: Regan Books/Harper Collins.
- Reisberg B., R. Doody, A. Stöffler, F. Schmitt, S. Ferris, and H. J. Möbius. 2003. Memantine in moderate-to-severe Alzheimer's disease. *New England Journal of Medicine* 348(14): 1333–1341.
- Roco, M. C., and W. S. Bainbridge (eds.). 2003. *Converging Technologies for Improving Human Performance*. Dordrecht, Netherlands: Kluwer.
- Roco, M. C., and C. D. Montemagno (eds.). *The Coevolution of Human Potential and Converging Technologies*. New York: New York Academy of Sciences.
- Rubin, R. 2004. "Smart pills" make headway. *USA Today* (7 July).
- Russo, E. 2002. Seeking smart drugs. *The Scientist* 16(21): 27–29.
- Ryoko Y., L. D. Johnston, and P. M. O'Malley. 2003. Relationship between student illicit drug use and school drug testing policies. *Journal of School Health* 73(4): 159–164.
- Sandeep, T. C., J. L. W. Yau, A. M. J. MacLulich, J. Noble, I. J. Deary, B. R. Walker, and J. R. Seckl. 2004. 11 $\beta$ -Hydroxysteroid dehydrogenase inhibition improves cognitive function in healthy elderly men and type 2 diabetics. *Proceedings of the National Academy of Sciences USA* 101: 6734–6739.
- Scott, R., R. Bourtchouladze, S. Gossweiler, J. Dubnau, and T. Tully. 2002. CREB and the discovery of cognitive enhancers. *Journal of Molecular Neuroscience* 2(19):171–177.

- Sententia, W. 2001. Brainfingerprinting: Databodies to databrains. *Journal of Cognitive Liberties* 2(3): 31–46.
- Sententia, W. 2004. Neuroethical considerations: Cognitive liberty and converging technologies for improving human cognition. Pp. 221–228 in M. C. Roco and C. D. Montemagno (eds.), *The Coevolution of Human Potential and Converging Technologies*. New York: New York Academy of Sciences.
- Shacter, D. 2001. *The Seven Sins of Memory: How the Mind Forgets and Remembers*. New York: Houghton Mifflin.
- Shapiro, M. H. 1991. Technologies of perfection: Performance enhancement and the control of attributes. *Southern California Law Review* 65: 11.
- Shapiro, M. H. 2002. Does technological enhancement of human traits threaten human equality and democracy? *San Diego Law Review* 39: 769.
- Shortell, S. M., T. M. Waters, K. W. B. Clarke, and P. P. Budetti. 1998. Physicians as double agents: Maintaining trust in an era of multiple accountabilities. *Journal of the American Medical Association* 280: 1102–1108.
- Snyder, A. W., E. Mulcahey, J. L. Taylor, D. J. Mitchell, P. Sachdev, and S. Gandevia. 2003. Savant-like skills exposed in normal people by suppressing the left fronto-temporal lobe. *Journal of Integrative Neuroscience* 2: 149–158.
- Tully, T., R. Bourtchouladze, R. Scott and J. Tallman. 2003. Targeting the CREB pathway for memory enhancers. *Nature Reviews Drug Discovery* 2: 267–277.
- Turner, D. C, T. W. Robbins, L. Clark, A. R. Aron, J. Dowson, and B. J. Sahakian. 2003. Cognitive enhancing effects of modafinil in healthy volunteers. *Psychopharmacology (Berl)* 165: 260–269.
- U.S. Food and Drug Administration. 2003. FDA approves memantine (Namenda) for Alzheimer's disease. FDA News PO3-82 (17 October). [www.fda.gov/bbs/topics/NEWS/2003/NEW00961.html](http://www.fda.gov/bbs/topics/NEWS/2003/NEW00961.html).
- U.S. National Institute on Drug Abuse. 2001. *Prescription Drugs: Abuse and Addition*. Research Report Series. U.S. Department of Health and Human Services. NIH Publication 01-4881, [www.nida.nih.gov/ResearchReports/Prescription/](http://www.nida.nih.gov/ResearchReports/Prescription/).
- Vincent, J.-D. (ed.). 1995. *Ethics and Neurosciences*. Paris: United Nations Educational, Scientific and Cultural Organization.
- White, H. 1987. *The Content of the Form: Narrative Discourse and Historical Representation*. Baltimore: John Hopkins University Press.
- Wolpe, P. R. 2003. Treatment, enhancement, and the ethics of neurotherapeutics. *Brain and Cognition* 50: 387–395.

## 12. NEUROPOLICY (2005–2035): CONVERGING TECHNOLOGIES ENABLE NEUROTECHNOLOGY, CREATING NEW ETHICAL DILEMMAS

Zack Lynch, *NeuroInsights*<sup>1</sup>

*Abstract:* A historical model of techno-economic change with socio-political adjustments is used to illuminate how neurotechnology will influence human society in the next three decades. The impact of neurotechnology in the financial sector is discussed with an overview of how the European Union and the United States are responding to the political and ethical issues that arise from advanced neurotechnology. The development of neurotechnology, tools that analyze and influence the nervous systems, is being accelerated by the convergence of NBIC technologies and will create new leading neurotech clusters.

### Introduction

People do a very poor job of predicting the future. Take Lord Kelvin, the physicist and president of the British Royal Society, who in 1895 insisted, “Heavier-than-air flying machines are impossible.” Or Ken Olson, President of Digital Equipment Corporation, who proclaimed in 1977, “There is no reason for any individual to have a computer in their home.” Inventors, themselves, often do not recognize the potential of their technologies. “The phonograph . . . is not of commercial value,” Thomas Edison declared after he had invented it in 1880.

And it is not just inventors or high-tech executives who get it wrong. People who are supposed to be on the cutting edge of cultural consciousness predict just as poorly, as a Decca Recording Company executive showed in 1962 after turning down the Beatles, “We don’t like their sound. Groups of guitars are on the way out.” Even as teams of highly educated professionals, we often miss the mark. “A severe depression like that of 1920–1921 is outside the range of probability,” stated the Harvard Economic Society on November 16, 1929, just weeks before the Great Depression began.

If forecasting a specific event or potential success of a new technology is difficult, then how can we confidently conceptualize how converging technologies will impact society? Most attempts at long-term social forecasting fall short because they extrapolate isolated technical advances occurring in one or two industries with little regard to other equally powerful agents of change (Spohrer and Englebart, 2004). Although technology is a

---

<sup>1</sup> I would like to acknowledge Dr. Tim-Rasmus Kiehl of the Harvard Medical School for his contribution to this chapter.

primary initiator of societal change, it also coevolves within a socio-cultural landscape not completely of its own making (Bell, 1973). Effective social forecasting on the scale of decades involves developing qualitative scenarios that are informed by the historical interplay of technology, economics, politics, and culture while remaining open to novel future conditions and combinations.

The model I use to understand the societal implications of converging technologies is not reductionist. Rather, it is a way of ordering and examining historical processes in order to illuminate some recurrent tendencies that can be used to understand our past, present, and future (Arthur, 2002). The roots of this model grow out of the observations made by the Russian economist Nikolai Kondratieff and the Austrian economist Joseph Schumpeter, who in the 1920s and 1930s described half-century-long waves of economic growth and decline reaching back to the 1700s (Schumpeter, 1939; Kondratieff, 1984). In more recent decades, economic historians Chris Freeman and Carlota Perez have expanded the model to encompass political and social trends through to the present day (Freeman, 1983; Perez, 2002; Lynch, 2004b).

Since the 1770s, five techno-economic waves with accompanying socio-political adjustments have driven societal change, as Table 1 outlines. Each wave has lasted approximately 50 years, and each has been driven a new set of converging technologies. We are currently nearing the final stage of the information technology wave and on the threshold of a sixth wave, driven by a whole new set of converging technologies. As many prominent thinkers have detailed, the convergence of NBIC technologies will impact many aspects of society, including manufacturing, education, and politics. Most importantly, today's set of converging technologies will open up a wide spectrum of new tools that will enable humans to improve our cognitive, emotional, and physical capabilities (Roco, 2004). As people live physically longer and healthier lives, mental health will become the preeminent social and political issue of our time.

### **Neuroenablement: New Tools for Our Brains**

In the past 200 years, the average human life span increased more than it did over the previous 10,000 years, from 25 to 70 years. Over the past 150 years, life expectancy has risen steadily at the rate of three additional months per year (Oeppen, 2002). To put this into perspective, in 1840 the average Japanese woman lived about 45 years, while today a girl born in Japan can expect to live almost 85 years. Projecting this trend forward suggests that average human life expectancy will reach 100 years by 2050, but forecasting life spans has never been an exact science.

**Table 1: Five Historical Techno-Economic Waves plus Neurotechnology**

	<b>Water Mechanization</b>	<b>Steam Mechanization</b>	<b>Electrification</b>
<b>Years</b>	1770–1830	1820–1880	1870–1920
<b>Driving Technologies</b>	Canals; water wheels	Coal, iron; steam engine	Electricity; copper, steel
<b>Economic Growth Sectors</b>	Cotton clothing; iron tools; canal transport	Railroads; locomotives; steam shipping	Steel products; construction; precision tools
<b>Political Support</b>	Enclosure acts; canal acts	Railroads U.S.: state paid 40%	AC/DC debate (10 years)
<b>Legal Issues</b>	Canal mania 1793; canal panic 1797	Railway mania 1836 (Great Britain)	USA 1893; Europe 1880s
	<b>Motorization</b>	<b>Information Technology</b>	<b>Neurotechnology</b>
<b>Years</b>	1910–1960	1960–2020	2010–2060
<b>Driving Technologies</b>	Oil	Microchip	Biochip (NB); brain imaging (IC)
<b>Economic Growth Sectors</b>	Oil refining; automobile; aircraft	Computers; networking; e-commerce	Biotechnology; nanotechnology
<b>Political Support</b>	Interstate highway system	ENIAC; Arpanet	Human genome; brain map project
<b>Legal Issues</b>	Mania 1923; crash 1929	Mania 1996; bubble 2000	Neuropolicy

Just as people have a hard time predicting new technologies, age researchers find it difficult to determine the life’s limits. For example, a famous 1928 study declared that the average maximum American life span would top out at 65 years (Oeppen, 2002), and a 1990 U.N. global population study asserted that life expectancy “should not exceed 35 years at age of 50 unless major breakthroughs occur in controlling the fundamental rate of aging” (Oeppen, 2002). This limit was surpassed 6 years later by Japanese women.

Today, anti-aging research is gaining momentum and promises to extend life spans further. Even without breakthroughs in life-extension research, current population projections suggest there will be 54 million Americans aged 85 years and older by 2040, up from 4.2 million today. Whereas today the oldest of the old, those 85 years and older, represent only 2% of the

population, by 2040 they could well represent almost 20%. This represents a fundamental change in the age structure not only of the U.S. population but also across the globe. For example, by 2050, the number of people over 60 years of age in Europe is estimated to double, to 40% of the total population. Never before in human history have so many people lived such long lives and shared the planet at one time.

As people live physically longer and healthier lives, mental health will become the preeminent social and political issue of our time. Mental health is the springboard of communication, learning, emotional growth, resilience, and self-esteem. Mental illness refers collectively to all mental disorders, characterized by alterations in thinking, mood, or behavior (or some combination thereof) associated with distressed or impaired functioning. Today, 5 of the 10 leading causes of disability worldwide (major depression, schizophrenia, bipolar disorders, alcohol use, and obsessive compulsive disorders) are mental illnesses. They are as relevant in poor countries as they are in rich ones, and all predictions point to a dramatic increase in mental illness in the coming decades.

Advances in nanotechnology, information technology, biotechnology, and cognitive science are the building blocks of better tools for mental health. Specifically, converging NBIC technologies will make possible neurotechnology – the set of tools that analyze and influence the brain and central nervous system.

### **NBIC Enables Neurotechnology**

To show how NBIC technologies directly support neurotechnology, the list below categorizes the focus areas provided in the Department of Health and Human Services's Neurotechnology Research, Development and Enhancement program announcement according to their primary focus within NBIC:

- Nanotechnology
  - Nanocrystals or quantum dots covalently bonded to neural receptor ligands
  - Microfluidic systems for *in vivo* spatial and temporal delivery of biomolecules
  - Microelectromechanical systems (MEMS) used for monitoring neurons
  - Nanoelectromechanical systems (NEMS) used for monitoring neurons
  - Amplifiers for mice to record neural activity from many neurons
  - Noninvasive optical imaging instruments
  - Tools for detection of acute neurological events
  - Improved electrodes, microcomputer interfaces, and microcircuitry

- Biotechnology
  - Proteome analysis arrays, proteome data storage, analysis of proteome data
  - Genetic approaches to study structure or function of neural circuits in animals
  - Biosensors that would be selectively activated by neurochemicals
  - Delivery systems for drugs, gene transfer vectors, and cells
  - Probes of brain gene expression that can be imaged noninvasively
  - Genetic approaches to manipulate or monitor synaptic activity
  - Tools for intervention and prevention of acute neurological events
- Information Technology
  - Software to translate neuroimaging data from one data format into another
  - Algorithms for understanding human neuroimaging data
  - Tools for real-time analysis of neurophysiological events
  - Dynamic monitors of intracranial pressure and spinal fluid composition
  - Devices for noninvasive diagnosis and precise identification of pathogens
  - Tools, technologies, and algorithms for neuroprosthesis development
  - Noninvasive tools to assess damage and monitor function in brain tissue
  - Tools for data mining into genomics and proteomics of the nervous system
- Cognitive Science
  - Noninvasive methods for *in vivo* tracking of implanted cells
  - Tools to enhance visualization of specific brain markers
  - New methods to study neural connectivity in living or postmortem brain
  - Tools for early-warning detection of imminent seizure activity
  - Methods to facilitate high-throughput analysis of behavior
  - Tools for therapeutic electrical stimulation for rehabilitation

Achieving these breakthroughs will require trillions of dollars of public and private investment over the next two decades. In the case of neurotechnology, two specific bottlenecks must be overcome: nanobiochips and noninvasive human neuroimaging. Nanobiochips that perform the basic bio-analysis functions (genomic, proteomic, biosimulation, and

microfluidics) at a low cost will transform biological analysis and production in a very similar fashion as the microprocessor did for data during the information technology wave (Lynch, 2004b).

Nano-imaging techniques will make possible real-time analysis of neuro-molecular level events in the human brain. The Human Brain Project is one example of a specific U.S. government-funded program focused on elucidating the brain's inner workings.<sup>1</sup> Similar to the successful Human Genome Project, the Human Brain Project will collect and correlate the ever-increasing volume of findings being generated from different studies of the human brain.

Figure 1 illustrates the declining cost of analysis per person and increasing resolution efficiency of nano-biochips and brain-imaging technologies over the next 40 years. The neurotechnology sweet spot represents the time period when we should expect fundamentally new tools and techniques for mental health to emerge.

**Figure 1. Technology Convergence Enables Neurotechnology**

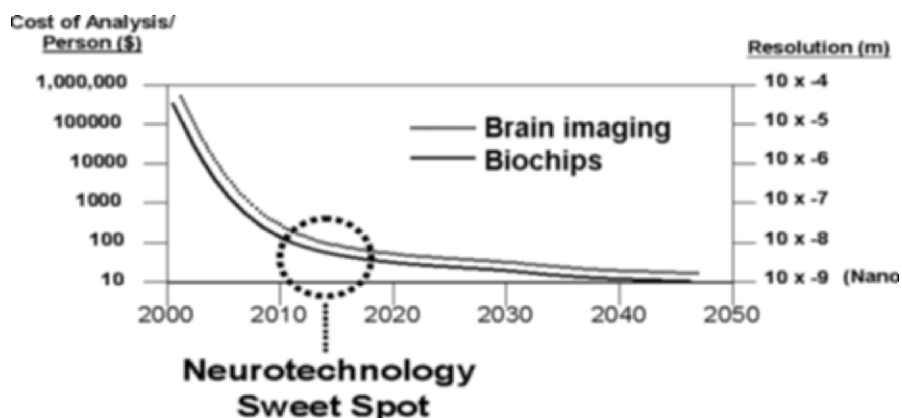

By marrying information from advanced brain imaging technology with the knowledge of molecular mechanisms provided by nanobiochips, a relatively complete understanding of the human brain will emerge (Canham *et al.*, 2002). This nanoscale resolution of the molecular drivers of mental health represents a profound leap in our understanding of how the brain functions, making possible the development of new tools to analyze and influence the human brain – neurotechnology.

<sup>1</sup> [grants.nih.gov/grants/guide/pa-files/PA-99-138.html](http://grants.nih.gov/grants/guide/pa-files/PA-99-138.html).



## **The Neurotechnology Industry – A Clear Taxonomy**

Today neurotechnology companies develop treatments for neurological diseases, psychiatric disorders, and nervous system illnesses. The neurotechnology industry also includes companies that supply brain imaging systems, diagnostic tools, databases, and neuropharmaceutical delivery systems. The neurotechnology industry contains three sectors:

- Neuropharmaceuticals: pharmaceuticals and biopharmaceuticals targeting the nervous system
- Neurodevices: medical devices, electronics and software for nervous system disorders
- Neurodiagnostics: brain imaging, molecular diagnostics, and informatics systems.

### *The Neuropharmaceutical Sector*

One of the difficulties in commercializing treatments for neurological disorders is the complex array of symptoms presented by many diseases. Consider schizophrenia, characterized by profound disruptions of numerous aspects of both cognitive and emotional functioning. For this reason, researchers have turned to targeting specific aspects of complex mental illnesses such as cognition, emotions, or sensory decline. The use of multiple targeted drugs in combination (i.e., drug cocktails) is called “polypharmacy” and is defined as using biopharmaceuticals and pharmaceuticals focused on the central nervous system. It can also be broken down into three categories, cognitivecuticals, sensoceuticals, and emoticeuticals. Certain complex disorders defy easy categorization and are thus placed in a fourth category, complex disorders. The most common neurological diseases and psychiatric disorders can be categorized with their respective market:

- Cognitivecuticals target memory-related problems, such as Alzheimer’s Disease (AD), mild cognitive impairment (MCI), attention deficit disorder (ADHD), and sleep disorders (insomnia).
- Sensoceuticals target problems of sensory and motors systems, such as deafness and blindness, Parkinson’s Disease (PD), epilepsy and seizure disorders, and neuropathic pain
- Emoticeuticals target mood-related illnesses, such as depression, bipolar disorder, and anxiety disorders (OCD, GAD, PTSD)
- Complex disorders, such as schizophrenia and psychosis, substance abuse and addiction, or cerebrovascular disease and stroke.

*The Neurodevice Sector*

Neurodevices, defined as medical devices, electronics, and information technology that treat nervous system disorders, are increasingly competing for market share and contribute to the growth of novel markets that cannot be fulfilled as effectively or quickly by neuropharmaceuticals. It is possible to understand these dynamics only by viewing both sectors as competing markets within the overall neurotechnology industry. The neurodevice sector contains four markets:

- Neural prosthetics are devices that substitute for an injured part of the nervous system, improving function, for example: cochlear implants (deaf people), retinal implants (blind people), and motor prostheses, BCI (paralyzed).
- Neurostimulation devices involve the use of electronic stimulation to induce or restore desired function or sensation, as in deep brain stimulation (DBS) for PD, vagus nerve stimulation (VNS) for epilepsy, and transcranial magnetic stimulation (TMS).
- Neurofeedback solutions are software training systems tied to biofeedback or neurofeedback to handle problems like autism, schizophrenia, ADHD, and dyslexia.
- Neurosurgical devices are devices and tools for use during neurosurgical procedures, such as stents and lasers.

*The Neurodiagnostics Sector*

Neurodiagnostics are the tools and technologies that neuropharmaceutical and neurodevice companies use for research and development (R&D) and that mental health professionals use for diagnosing and monitoring mental disorders technologies. The diagnostics sector can be broken into three markets:

- Neuroimaging: includes both structural imaging systems such as MRI and CT and functional imaging systems (e.g. fMRI, PET, SPECT, EEG, MEG)
- Biomarkers: identify disease subtypes, predict therapeutic responses
- Neuroinformatics: includes the shared databases in standardized digital form, and integrating information from the level of the gene to behavior.

In addition to reducing the psychological, social, and economic impact of mental illness, neurotechnology will also enable individuals to improve specific cognitive, emotional, and physical capabilities. As life spans increase

and global competition intensifies, neurotechnology will enable individuals and companies to compete more effectively. This will allow companies to surpass today's information technology-based competitive advantage, and instead compete within a realm that I call neurocompetitive advantage.

### **Neurocompetitive Advantage**

Mental health is the ultimate competitive weapon, underpinning the creation of intellectual capital and competitive advantage. It anchors the capacity of employees, managers, and executives to think, use ideas, be creative, and be productive. Like never before, businesses depend upon consistent, sustainable mental performance. Any way mental health can be improved to increase profit margins will be sought.

As neurotechnology spreads across industries, it will create a new economic "playing field" wherein individuals who use it will have the capacity to achieve a higher level of productivity than those who do not. As with previous waves, information technology has completely transformed the ways that individuals, businesses, and governments operate on a day-to-day basis. For example, by investing in e-mail and teleconferencing systems, businesses have accelerated communication flow among workers and, in the process, reshaped the structure of their organizations (Malone, 2004). Similarly, national governments that have invested in new telecommunication infrastructures, education curriculum, and regulatory authorities have accelerated information technology adoption (Bainbridge, 2004).

Just as the wheel, railroads, and electricity remain critical infrastructures that underpin the functioning of today's global economy, so too will effective information systems be a prerequisite to compete in any future economy (Spohrer and Englebart, 2004). Indeed, there is no way the past 10 years of advances in biotechnology would have been possible without the computational capabilities brought forth by ever-more-powerful microchips.

By radically reducing the spatial transaction cost of sharing knowledge, information technology has transformed the global economic landscape, creating in its wake new industries, organizational capabilities, and employment opportunities performs. As instantaneous information becomes available to workers across the globe in the next decade, the ability to analyze and act on information will no longer determine organizational effectiveness. Instead, neurotechnology will emerge as the critical ingredient of success.

### Neurotechnology Clusters

The concept of technology clusters became popular with Harvard economist Michael Porter's book *The Competitive Advantage of Nations* (Porter, 1990). It describes them as geographic concentrations of interconnected companies, suppliers, service providers, firms in related industries, and associated institutions in particular fields that compete but also cooperate.

Earlier clusters evolved chiefly by a coincidence of factors: research facilities, educated workforce, venture capital, experienced managers, and proximity of supplier networks. Subsequent clusters were the result of focused initiatives, especially as biotech became a "must have" industry. This approach may not be useful in every case, and not all efforts will succeed (Sheridan, 2003). The following examples illustrate the strengths and differences of some locations.

In a recent survey (DeVol *et al.*, 2004), the San Diego metropolitan area ranked first among U.S. biotech clusters. Its life science industry includes large multinationals plus numerous smaller biotech and medical device companies. Employment is over 55,000, and the sector generates \$5.8 billion in local income.

In Singapore, "Biopolis" opened its doors in October 2003. This ready-made, planned cluster houses publicly funded R&D labs and biotechnology and pharmaceutical companies, as well as venture capital firms, law firms, and others. It is hoped that the close proximity of these elements will facilitate innovation and commercialization and lead to a mature, self-sustaining industry.

Located at the University of Southern California, the National Science Foundation Engineering Research Center devoted to Biomimetic Microelectronic Systems (BMES) was unveiled in 2003. This neurotechnology team effort by four universities combines academic research with commercial development. It has attracted the interest of numerous corporations in fields ranging from medical devices and biotechnology to information processing and electronic imaging. The industrial partners deliver technology and funding. They also pay an annual membership fee, giving them access to the center's pool of researchers and intellectual property. The University of California–Los Angeles (UCLA) has become an important neuroimaging center, which has led to large consortia (International Consortium for Brain Mapping).<sup>1</sup>

A genuine neurotechnology cluster has yet to emerge. For now, the National Science Foundation (NSF) "converging technologies" report provides a vague outline. So, which locations are the most likely to produce

---

<sup>1</sup> [www.loni.ucla.edu/ICBM/](http://www.loni.ucla.edu/ICBM/).

the neurotech hotspots? The United States already has a lead in all of the basic technologies and is yet again positioned for leadership.

One of the most likely regions to develop as a nexus for neurotechnology is the San Francisco Bay Area. It has a leading nanotechnology presence from both corporate and academic perspectives (IBM, Nanosys, University of California at Berkeley, Stanford, Foresight Institute), it benefits from the information technology leadership of Silicon Valley (Intel, Apple, Cisco, IBM), it is the birthplace of biotechnology in South San Francisco (Genentech, Affymetrix, Agilent), and it has two of the leading neuroscience universities (University of California–San Francisco and Stanford). With its fertile confluence of inventors, scientists, venture capital, and entrepreneurs, the Bay Area seems to have all the ingredients to become an NBIC cluster.

Japan, China, and South Korea have provided generous public funding for nanotechnology and also have a competitive position in the other NBIC components. The recent biotechnology initiative in Singapore demonstrates great interest in nurturing new industries. Regions that were previously limited to particular sectors have diversified (e.g., Bio Bangalore initiative), and others actively foster tech convergence (e.g., Cornell Nanobiotechnology Cluster in Ithaca, N.Y.).

Whether neurotechnology clusters will emerge more rapidly or slower than those of previous technology waves is unclear. Arguing for fast, disruptive change is the fact that well-established building blocks are already present today. In the early phases of the neurotechnology wave, high global demand for human performance enhancement will drive research and investment. Some of the most productive clusters will specialize in creating unique combinations and applications of technologies that were developed elsewhere. Interestingly, by offering tools to break down these very barriers between disciplines, neurotechnology can create self-sustaining innovative momentum.

### **Neurofinance: Forecasting Emotions**

Financial organizations have always been at the forefront of adopting, testing, and disseminating the latest driving technology. Always searching for the new ways to increase transaction effectiveness and improve decision accuracy, financial analysts continuously seek out the latest tools to attain competitive advantage.

During the water mechanization wave (1770–1820), banks in England were among the first organizations to use the penny post to decrease transportation and communication costs (Freeman and Louçã, 2001). Most recently, the emergence of a global financial trading system during the 1970s and 1980s made instant currency and financial trading possible across the

planet. Yet, as the following example will show, information technology-based competitive advantage has limits.

Founded in 1993, Long Term Capital Management (LTCM) possessed a team of financial superstars, including Myron Scholes and Robert Merton, who were awarded the Nobel Prize in economics in 1997 for their work on derivatives and financial risk analysis. Backed by a world-class team of financial wizards and supported by the latest mathematical modeling supercomputers, LTCM quickly became a major global player in relative value trading.

In the summer of 1998, however, LTCM's reliance on mathematical models almost brought the entire global financial system to its knees. Among the many mistakes LTCM made was not taking into consideration the emotional responses that financial traders would make in stressful situations (Kolman, 1999). According to their models, and standard economic theory, a bond that is too cheap should attract buyers. Following this logic, they would buy contracts at very low prices in order to increase the spread that they would receive when selling the contract in the future.

As LTCM later admitted, their models were not fully aware of market price dynamics. In fact, in a "skittish" market, lower prices can actually act to repel buyers, as they avoid becoming involved with more potentially painful situations. This failure represented such a profound threat that the Federal Reserve found it necessary to help organize the effort to forestall LTCM's bankruptcy (Dowd, 1999). At the request of the U.S. Federal Reserve, 14 international banks responded, averting a potential collapse of the global financial system.

The lesson from LTCM is clear: people are not the rational actors standard economic theory would make them out to be. Instead, our emotional reactions to future events play an important role in our decisions. Although there has been a longstanding controversy in economics as to whether financial markets are governed by rational forces or by emotional responses, neuroeconomists have recently shown that emotions profoundly influence the decision-making process (Lowenstein, 2000; Glimcher, 2003).

Two important insights have come from research into emotional forecasting. First is that decisions made in one emotional state are vastly different from those the same person would make in a different state (Gilbert and Wilson, 2000). This empathy gap, the difference between how we behave in "hot" states (those of anxiety, courage, fear, drug craving, sexual excitation, and the like) and "cold" states (rational calm), drives significantly different decisions. The decisions made in these states have the ability to change us so profoundly that we are more different from ourselves in different states than we are from another person in a similar state (Gertner, 2003).

The second insight is that individuals almost always overestimate the happiness that an event, like a purchase, will bring. For example, although we might believe a new BMW will make life much better, it will likely be less exciting than anticipated and it will not excite us for as long as we thought. This difference is known as impact bias (Loewenstein and Adler, 1995). That is, individuals have a tendency to make an error (“bias”) about the intensity and duration, the impact, of how a happy a current decision will ultimately make them feel.

So, how will financial institutions use neurotechnology to reduce a trader’s impact bias and empathy gap? Neurotechnology-enabled traders will have at least two new tools at their disposal. First, they will have neurofeedback systems that reduce overestimation by providing them with real-time impact bias feedback that highlights their bias on previous decisions. Neurofinance researchers are already measuring physiological characteristics (e.g., skin conductance, blood volume pulse) during live trading sessions while simultaneously capturing real-time prices from which market events can be detected (Lo and Repin, 2002). Although biofeedback has already shown promise in improving team decision making, plans are already being discussed to use neuroimaging to better understand the neurobiology of financial decision making.

A second set of tools that financial traders could use to stabilize their emotional state is neuropharmaceuticals that reduce their empathy gap. For example, emoticeuticals could be triggered when a trader was in a particular “hot” state. The baseline for the trigger would be individualized for each trader based upon which “hot” states resulted in less-profitable decisions in the past.

The implications of neuroeconomics research will reach well beyond the finance industry. Emotional forecasting could greatly influence retirement planning, for example, where mistakes in prediction (e.g., how much we save, how much we spend, or how we choose a community we think we’ll enjoy) can prove irreversible (Gertner, 2003). It could also impact consumer spending, where a “cooling off” period might remedy buyer’s remorse or reduce poor health care decisions, especially when it comes to informed consent (Loewenstein *et al.*, 2003).

Some suggest that a life without forecasting errors would most likely be a better, happier life. “If you had a deep understanding of the impact bias and you acted on it, which is not always that easy to do, you would tend to invest your resources in the things that would make you happy,” explains Daniel Gilbert (Gertner, 2003).

Neurotechnologies are tools that help ordinary people reduce their empathy gap and gain control over their impact bias, but is this really a good thing for society? Looking forward, we need to understand what a neurotechnology-infused world would look like. Will neurotechnology-

enabled individuals make different decisions? If so, how will those decisions impact others? Clearly, the emergence of neurotechnology raises novel ethical and political dilemmas.

### **Europe Deliberates the Neurosociety**

Neurotechnology holds both promises and problems for humanity. On the up side, neurotechnology represents new cures for mental illness, new opportunities for economic growth, and a potential flowering of artistic expression (Zeki, 1999, 2001). These benefits are countered by its potential use in the areas of forced testing for employment, coercive law enforcement, and asymmetric neurowarfare.

Divisions will emerge across all levels of society as humanity grapples with this new way of living, impacting each nation and culture differently. The United States, Great Britain, Nazi Germany, and the late Soviet Union were considered industrial societies, but they all also had distinct cultural and political systems. Similarly, neurosocieties will develop their own unique variations.

The growing acknowledgment that humanity is entering an era driven by neurotechnology is evidenced by a recent meeting held in April 2004 in Amsterdam: “Connecting Brains and Society, the Present and Future of Brain Sciences: What is Possible, What is Desirable?” As one of the organizers poignantly remarked, “Brain sciences are not only about treating diseases, they form an important narrative about what it is to be human. That is why it is important to have a societal discussion about what is going on in the field.”<sup>1</sup>

Twenty-five European top level scientists were invited to this informative workshop to give their views on the developments in brain sciences. Among the hand-selected participants were physicians, psychiatric, cognitive and social scientists, philosophers, artists, and representatives of stakeholder organizations (i.e., the pharmaceutical industry, the European Brain Council,<sup>2</sup> the European Federation of Neurological Associations,<sup>3</sup> the Global Alliance of Mental Illness Advocacy Networks,<sup>4</sup> and the European Dana Alliance for the Brain).<sup>5</sup>

Baroness Susan Greenfield, director of the Royal Institution of Great Britain, summed up the meeting by stating, “Appreciating the dynamism and sensitivity of our brain circuitry, the prospect of directly tampering with the essence of our individuality seems to become a possibility” (Duncan, 2003).

---

<sup>1</sup> [www.kbs-frb.be/files/db/EN/PUB\\_1466\\_SYNOE\\_Connecting\\_Brains\\_society.pdf](http://www.kbs-frb.be/files/db/EN/PUB_1466_SYNOE_Connecting_Brains_society.pdf).

<sup>2</sup> [www.europeanbraincouncil.com/](http://www.europeanbraincouncil.com/).

<sup>3</sup> [www.efna.net](http://www.efna.net).

<sup>4</sup> [www.gamian.org/](http://www.gamian.org/).

<sup>5</sup> [www.edab.net/](http://www.edab.net/).



Neurotechnology that enables individuals to consciously shape their personality will impact how people perceive each other, family relationships, political rhetoric, and economic crises. This “perception shifting” will not only challenge our ethical standards, but directly impact our legal and political systems.

### **Evolving Neuropolicy Issues**

As we enter the “neuroage,” we find ourselves facing new dilemmas. As the President’s Council on Bioethics’s recently released report “Beyond Therapy: Biotechnology and the Pursuit of Happiness” explains, “Advances in genetics, drug discovery and regenerative medicine promise cures for dreaded diseases and relief for terrible suffering. Advances in neuroscience and psychopharmacology promise better treatments for the mentally ill” (Kass, 2003). The report then cautions against using new technologies for enhancement purposes:

We want better children – but not by turning procreation into manufacture or by altering their brains to give them an edge over their peers. We want to perform better in the activities of life – but not by becoming mere creatures of our chemists or by turning ourselves into tools designed to win and achieve in inhuman ways. We want longer lives – but not at the cost of living carelessly or shallowly with diminished aspiration for living well, and not by becoming people so obsessed with our own longevity that we care little about the next generations. We want to be happy – but not because of a drug that gives us happy feelings without the real loves, attachments and achievements that are essential for true human flourishing.<sup>1</sup>

Using neurotechnology for performance enhancement will not come without protest (Sandel, 2004). Cultural concerns regarding what is “natural” will lead to religious, moral, and political tensions around the basic right to augment oneself (Caplan, 2003). Although ethical concerns around neuro-enhancement are very real, neuro-cognitive enhancement is already a fact of life for some (Lynch, 2004a). For example, use of prescription stimulants (such as methylphenidate) as study aids has already reached above 15% of students on some college campuses (Babcock, 2000).

As Amartya Sen has wisely suggested, we should focus on improving human capabilities, not just performance. Following this spirit, others are concerned about cognitive liberty in an era of neurotechnology, suggesting that “freedom of thought” is the primary civil rights issue of our emerging

---

<sup>1</sup> [www.cognitiveliberty.org/neuro/beyond\\_therapy\\_released.html](http://www.cognitiveliberty.org/neuro/beyond_therapy_released.html).

neurosociety (Sententia, 2004). As ethical debate continues, the technology continues to move forward. So how might neuropolicy issues evolve in the coming decades?

Today, neuroethicists are debating issues of national security versus individual liberty. For example, will governments have the right to mandate brain scans of suspected criminals? Is it right to use neuropharmaceuticals to control the actions and thoughts of convicted individuals? Should the right to privacy be extended to include brain privacy (Boire, 2000)? Although some argue that the capabilities of the human mind should not be limited and that governments should not criminally prohibit mental enhancement, others contend that access to enhancement technologies will be unequal, and therefore should be made illegal (Fukuyama, 2002).

Table 2 outlines the possible progression of neuropolicy issues over the next 30 years. As the competitive edge provided by neurotechnology becomes apparent, the debate will shift to the right of individuals to use these new tools to improve them versus the unfair playing field that will result from unequal access to performance enhancers. At the same time, the legal implications of forced testing with brain-scanning technologies for education, employment, and security will come to the fore.

**Table 2: The Progression of Neuropolicy Issues, 2000–2030**

<b>Issue</b>	<b>2000–2010</b>	<b>2010–2020</b>	<b>2020–2030</b>
<b>Ethical</b>	Security versus liberty	Enablement versus enhancement	Temporary versus permanent
<b>Legal</b>	Brain privacy; Accountability	Tests required versus noncompliance	Use required versus freedom

By 2020–2030, the debate will evolve into a discussion of whether or not we should genetically engineer some of the behavioral traits that have been explored with neurotechnology (Stock, 2002). In the legislative arena, the competitive necessity of using these new tools will cause great concern over whether or not they will be required just to compete in tomorrow's global economy. As a group of neuroethicists recently commented, "What if keeping one's job or remaining in one's school depends on practicing neurocognitive enhancement?" (Farah *et al.*, 2004).

By looking at history, it is possible to envision how waves of techno-economic change instigate socio-political responses and how this model can begin to help us understand how converging technologies will impact human society in the years to come. Although many of the ethical and moral dimensions of our emerging neurosociety are new, it is possible to look back on history to learn the ways that humanity has responded intelligently to the impact of converging technologies.

## References

- Arthur, B. 2002. Is the information revolution dead? *Business 2.0*, March, [www.business2.com/b2/](http://www.business2.com/b2/).
- Babcock, Q. 2000. Student perceptions of methylphenidate abuse at a public liberal arts college. *Journal of American College Health* 49: 143–145.
- Bell, D. 1973. *The Coming of the Post-Industrial Society: A Venture into Social Forecasting*. New York: Basic Books.
- Bainbridge, W. S. 2004. The evolution of semantic systems. Pp. 150–177 in M. C. Roco and C. D. Montemagno (eds.), *The Coevolution of Human Potential and Converging Technologies*. New York: New York Academy of Sciences.
- Blakeslee, S. 2003. Brain experts now follow the money. *New York Times Magazine*. September 7: F1.
- Boire, R. 2000. On cognitive liberties part III. *The Journal of Cognitive Liberties* 2: 7–22.
- Braun, S. 2000. *The Science of Happiness: Unlocking the Mysteries of Mood*. New York: John Wiley and Sons.
- Canham, R. S. Saffie, S. E. Connor, and R. Aston L.T. 2002. Silicon technology and pharmaceuticals-an impending marriage in the nanoworld. *Drug Discovery World* (Fall): 56–63. [www.ddw-online.com/](http://www.ddw-online.com/).
- Caplan, A. L. 2003. Is better best? *Scientific American* September: 68–73.
- Carlsson, A. 2001. A paradigm shift in brain research. *Science* 294: 1021–1024.
- DeVol, R. C., P. Wong, J. Ki, A. Bedroussian, and R. Koepp. 2004. America's biotech and life science clusters: San Diego's position and economic contributions. Milken Institute Research Report.
- Dowd, K. 1999. Too big to fail? Long-term capital management and the Federal Reserve. Cato Briefing Paper 52, [www.cato.org/pubs/briefs/bp52.pdf](http://www.cato.org/pubs/briefs/bp52.pdf).
- Duncan, A. 2003. Interview with Susan Grienfield. [members.fortunecity.com/templarser/duncan1.html](http://members.fortunecity.com/templarser/duncan1.html)
- Economist. 2002. The ethics of brain science. *The Economist* May 23: 77–79.
- Farah, M., J. Illes, R. Cook-Deegan, H. Gardner, E. Kandel, P. King, E. Parens, P. R. Wolpe, and B. Sahakian. 2004. Neurocognitive enhancement: What can we do and what should we do? *Nature Reviews Neuroscience* 5: 421–425.
- Freeman, C. 1983. *Long Waves in the World Economy*. London: Frances Pinter.
- Freeman, C, and F. Louçã. 2001. *As Time Goes by: From the Industrial Revolutions to the Information Revolution*. New York: Oxford University Press.
- Fukuyama, F. 2002. *Our Posthuman Future: Consequences of the Biotechnology Revolution*. New York: Farrar, Strauss, Giroux.
- Gertner, J. 2003. The futile pursuit of happiness. *New York Times* September 7: Section 6: 44.
- Glimcher, P. W. 2002. *Decisions, Uncertainty, and the Brain: The Science of Neuroeconomics*. Cambridge, Mass.: MIT Press/Bradford Press.
- Glimcher, P. W. 2002. Decisions, decisions, decisions: Choosing a biological science of choice. *Neuron* 36(2): 323–332.

- Gilbert, D. T., and T. D. Wilson. 2000. Miswanting: Some problems in the forecasting of future affective states. In J. Forgas (ed.), *Thinking and Feeling: The Role of Affect in Social Cognition*. Cambridge: Cambridge University Press.
- Kass, L. R. Thursday. 2003. The pursuit of biohappiness. *Washington Post* (October 16): A25.
- Kolman, J. 1999. LTCM speaks. *Derivatives Strategy Magazine* April: 25–32.
- Kondratieff, N. D. 1984. *The Long Wave Cycle*. New York: Richardson and Snyder.
- Lo, A. W., and D. V. Repin. 2002. The psychophysiology of real-time financial risk processing. *Journal of Cognitive Neuroscience* 14: 323–339.
- Loewenstein, G. 2000. Emotions in economic theory and economic behavior. *American Economic Review: Papers and Proceedings* 90: 426–432.
- Loewenstein, G., and D. Adler. 1995. A bias in the prediction of tastes. *Economic Journal* 105: 929–937.
- Loewenstein, G., T. O'Donoghue, and M. Rabin, M. 2003. Projection bias in predicting future utility. *Quarterly Journal of Economics* 118(4): 1209–1248.
- Lynch, Z. 2004a. Emotions in art and the brain. *Lancet Neurology* 3: 191.
- Lynch, Z. 2004b. Neurotechnology and society 2010–2060. Pp. 229–233 in M. C. Roco and C. D. Montemagno (eds.), *The Coevolution of Human Potential and Converging Technologies*. New York: New York Academy of Sciences.
- Malone, T. 2004. *The Future of Work*. Boston: HBS Press.
- Oeppen, J. W. 2002 Broken limits to life expectancy. *Science* 296: 1029–1031.
- Pope, A. T., and O. S. Palsson. 2003. Converging technologies for physiological self-regulation. Pp. 260–270 in M. C. Roco and W. S. Bainbridge (eds.). 2003. *Converging Technologies for Improving Human Performance*. Dordrecht, Netherlands: Kluwer.
- Perez, C. 2002. *Technological Revolutions and Financial Capital: The Dynamics of Bubbles and Golden Ages*. Northampton, Mass.: Edward Elgar.
- President's Council on Bioethics. 2003. *Beyond Therapy*. New York: Regan Books.
- Porter, Michael E. 1990. *The Competitive Advantage of Nations*. New York: Free Press.
- Roco, M. C. 2004. Science and Technology Integration for Increased Human Potential and Societal Outcomes. Pp. 1–16 in M. C. Roco and C. D. Montemagno (eds.), *The Coevolution of Human Potential and Converging Technologies*. New York: New York Academy of Sciences.
- Rosenthal, N. E. 2002. *The Emotional Revolution*. New York: Citadel Press.
- Sandel, M. J. 2004. The case against perfection. *Atlantic Monthly* 293(3).
- Schumpeter, J. 1939. *Business Cycles: A Theoretical, Historical and Statistical Analysis of the Capitalist Process*. New York: McGraw-Hill.
- Sententia, W. 2004. Neuroethical considerations: Cognitive liberty and converging technologies for improving human cognition. Pp. 221–228 in M. C. Roco and C. D. Montemagno (eds.), *The Coevolution of Human Potential and Converging Technologies*. New York: New York Academy of Sciences.
- Sheridan, C. 2003. Benefits of biotech clusters questioned. *Nature Biotechnology* 21(11):1258–1259.
- Spohrer, J. C., and D. C. Englebart. 2004. Converging technologies for enhancing human performance: Science and business perspectives. Pp. 50–82 in M. C. Roco and C. D. Montemagno (eds.), *The Coevolution of Human Potential and Converging Technologies*. New York: New York Academy of Sciences.

- Stock, G. 2002. *Redesigning Humans, Our Inevitable Genetic Future*. New York: Houghton Mifflin.
- Zeki, S. 1999. *Inner vision: An Exploration of Art and the Brain*. New York: Oxford University Press.
- Zeki, S. 2001. Artistic creativity and the brain. *Science* 293(5527): 51-52.

## 13. INFORMATION TECHNOLOGY AND COGNITIVE SYSTEMS

*Robert St. Amant, North Carolina State University*

*Abstract:* This chapter explains the basic cognitive modeling approach to managing complexity in information technology. It begins with an overview of cognitive modeling and then discusses three directions in which cognitive modeling has influenced information technology: improving existing user interfaces to information technology, evaluating new ways in which information technology can be tailored to user needs, and pointing toward novel paradigms for interacting with information.

### Introduction

Two of the central goals in the field of human–computer interaction (HCI) are to make information technology more accessible to non-technical users and to ensure that the technology is easy to use. Unfortunately, these goals often come into conflict. If we contrast a modern word processor, a Web browser, or even a mobile telephone with its counterpart of 10 years ago, we find an enormous increase in capabilities. Designers and developers must take great care that new functionality is not accompanied by corresponding increases in complexity.

The past several years have seen a growing consensus on the importance of understanding and modeling users' cognitive capabilities in building effective systems for interacting with information technology. We use the term “cognitive” here very broadly, to encompass the properties of perception, attention, memory, problem solving, learning, and even motor activity. At the most basic level, user interfaces should be designed with well-established psychological principles in mind: users cannot retain more than a few items in memory when moving from one interface dialog to another, users find it difficult to understand arbitrarily structured information layouts, users can recognize familiar visual icons more easily than they can recall the names and syntax of complex typed commands.

Research in task analysis and cognitive modeling takes such principles a step further. Rather than aiming toward a list of guidelines for interface development, cognitive modeling researchers propose that such information be integrated into a unified cognitive architecture, essentially a general-purpose engineering model of human cognition that can make predictions about user performance in interactive computing environments (Byrne, 2002). The most influential cognitive architectures in current HCI research are Soar (Newell, 1990), ACT-R (Anderson and Lebiere, 1998), and EPIC (Kieras and Meyer, 1998). The key insight leading to the development of these architectures is that if general models of cognitive processing can be

developed and validated over a wide range of general behaviors, then the models will become robust enough to be applied to new domains without the need for extensive tailoring to every new specialized problem that arises.

### **Cognitive Modeling**

The roots of cognitive modeling can be found in techniques for task analysis, which go back to studies of efficient motion in the early 1900s. Task analysis has met with significant success in HCI. One of the best-known efforts is Project Ernestine (Gray *et al.*, 1993). Project Ernestine was carried out by researchers at Carnegie Mellon University on behalf of the telephone company NYNEX. The goal of the project was to analyze the performance of toll assistance operators in order to evaluate whether new workstations that had been proposed would actually improve performance. The analysis techniques applied by the researchers were based on an approach called GOMS (John and Kieras, 1996). GOMS models represent the goals, actions, and decisions that users must consider in solving problems with an interactive system. This level of analysis turns out to give considerable leverage in predicting how well users will be able to interact with a system. The GOMS analysis produced convincing evidence that the new workstations for operators would actually degrade performance, contrary to expectations. The project resulted in a savings of almost \$2 million per year to the company. The key pragmatic lessons learned from the application of GOMS techniques, aside from the scientific value of the models, were that detailed analysis of user behavior could make a practical difference in the design of an interactive system in a highly demanding environment, and that such an analysis can lead to a more detailed understanding of complex interactive processes.

Cognitive modeling can be thought of as pushing task analysis to a deeper level of detail, not only by modeling the goals, actions, and decisions of the user but also by grounding the analysis in a model of human cognitive processing. A prominent success story in the use of cognitive technology is the Soar Intelligent Forces (IFOR) project (Rosenbloom *et al.*, 1994). The Soar IFOR project had the goal of developing automated pilots (agents) for large simulated battlefields. Because these agents need to cooperate smoothly with human pilots in the environment, their behavior must be essentially indistinguishable from that of humans. The agents model human behavior well enough that they have been able to participate successfully in multi-day military exercises, with their performance at times approaching that of expert human pilots. These and comparable projects demonstrate that cognitive models can capture the details of human behavior in dynamic environments that require problem solving, monitoring and responding to changes in real time, improvising and acting opportunistically, and strategic planning.

Central to the success of cognitive modeling projects is the concept of a unified cognitive architecture. Unified cognitive architectures are computational models of human cognitive processing, generally including representations of memory, attention, visual and motor processing, problem solving, learning, and related phenomena. To understand how a cognitive architecture can be used to influence design, it will be helpful to see the basic structure of a specific cognitive architecture, though all the architectures mentioned above (ACT-R, Soar, and EPIC) share some basic similarities. For our illustration we use ACT-R (Anderson and Lebiere, 1998).

In ACT-R, knowledge can be stored in two ways. There is declarative knowledge (facts and relationships that a user is aware of and can describe) and procedural knowledge (“how to” knowledge about how to solve problems). The former structures are called chunks, the latter productions. Productions take the form of if-then rules that act on chunks in memory. For example, for a database application, chunks may represent the names and types of data columns, and the functionality associated with different menu options. Productions might encode the procedural knowledge that in order to produce a data plot, data columns of a specific type must be selected and a specific menu item must be chosen. Driving the activation of productions are goals representing the desired state of the application.

Building cognitive models of this type allows us to make inferences and generate explanations about how users pursue their goals. For example, we might observe that when users carry out two apparently similar sequences of operations in an application, the durations of the tasks are significantly different. By developing and running a cognitive model for the two tasks, we might be able to determine that information that should guide the user’s decision-making is made visible by the application in one case but not in the other, forcing the user to retrieve the information from memory. A wide range of explanatory hypotheses can be constructed and evaluated with the help of a cognitive model, avoiding the cost and difficulties of eliciting explanations from users (which may, in any case, not even be consciously accessible.) Such hypotheses can operate on phenomena related to visual processing, motor action, memory retrievals, and problem solving. Cognitive models thus can be thought of as precise and detailed instruments for evaluating user performance.

### **Improving Existing User Interfaces**

As discussed above, cognitive models represent user behavior at a level of detail sufficient to allow not only prediction but simulation. Given a user interface to information technology, cognitive models can be used to explore the performance characteristics of the interface to evaluate its effectiveness and to suggest improvements.



One attractive target for evaluation based on cognitive modeling has been menu selection. Most user interfaces for productivity applications rely heavily on menus in giving users access to functionality. Unfortunately, even the simplest applications may have dozens or even hundreds of menu options to choose from. If menus are poorly structured in an application, then novice users may become lost in trying to interact with the application, and even expert users will not be able to use the application efficiently. Cognitive modeling research has found, for example, that users' behavior in traversing menus can be interpreted as a mixture of directed and random search for specific menu items (Hornof and Kieras, 1997).

In our work, we have applied cognitive modeling techniques to improve the usability of menu hierarchies on cellular telephones. Why cell phones? It is estimated that there are a billion cell phones in use today, and that this number will double by 2007. Cell phones are used for more than making calls – they include tools for managing contact information, voice mail, and hardware settings, and often software for playing games, browsing the Web, and connecting to specialized information services. Cell phones and other mobile devices are often viewed as a critical element in environments in which information is made accessible when and where it is needed.

In a recent study (St. Amant *et al.*, 2004), we evaluated the efficiency of the menu hierarchy of a typical cell phone to determine how performance might be improved. Even for simple tasks that require only selecting items one at a time from a cascading sequence of menus, to launch a Web browser or retrieve information about hardware settings, alternative ordering and naming of the items can produce large differences in performance. We developed and evaluated models that represent user behavior at three different levels of detail: a model that represented motor activity only (i.e., finger movements and button presses on the cell phone keypad); a GOMS model that in addition captured goals and task structure, including memory retrievals of relationships between menu items; and an ACT-R model that subsumed all of these factors, with the addition of modeling shifts of visual attention. The GOMS and ACT-R models were able to predict user performance with striking accuracy, to within 10 milliseconds per task.

With these models in hand, we can then ask, "How might cell phone menus be improved?" Cognitive models act as engineering models of performance: We can use them to explore the space of potential improvements to an interface. We used the GOMS and ACT-R models to define a simple performance metric for the duration of selecting menu items. We then developed an automated search procedure to generate new menus that could be tailored to different performance profiles. In simulation studies, we found that the search procedure generated menus that could be traversed 33% more efficiently than existing menus, on average – a significant savings.

As one reader commented, “If a second could be taken off every cell phone interaction, that would mean [aggregate] savings of lifetimes.”

This is a very specialized application of cognitive modeling to the evaluation of interactive systems, but it is indicative of much more general possibilities. First, models can help us better understand computer-based problem-solving in using information technology (Ritter *et al.*, 2000) at a very detailed level. Second, models can direct the attention of designers to specific problematic areas of interaction with information technology, where seemingly minor changes may produce significant improvements in usability. Third, models can be applied as surrogate users, saving enormous amounts of time and energy during the iterative evaluation stages of software development. Finally, models give designers insight into how information systems are used:

- What information is needed at different times
- How information is interpreted in different situations
- How errors arise and can be avoided
- How decisions about interface design affect the interaction process.

### **Developing and Evaluating Novel User Interfaces**

A related area of impact that cognitive modeling has begun to have on information technology is in suggesting novel, perhaps entirely different, ways of interacting with information. One area in which significant progress has been made is information navigation.

Humans have been described as *informavores*, navigating through information-rich environments (Pirolli, 2003; Pirolli and Card, 1999). Just as animals have different ecological niches in which they pursue their goals of foraging for resources, competing against others and the environment, humans can be thought of as following a comparable process in exploring virtual worlds and making decisions to acquire information. If we take this view of information technology, then cognitive models can provide insight into how information is interpreted, how exploration strategies are formed and revised, and how knowledge and goals influence decision-making.

Pirolli and Card’s theoretical and practical results have driven this area of research. Key concepts deal with the economics of attention, optimal-foraging theory and models, foraging mechanisms and strategies, and information scent. Optimal-foraging theory explains behavior adaptations in terms of resource availability and constraints. Information scent is a metaphor for proximal cues that guide users in navigating toward distal information. For example, if a researcher is looking for information about a particular topic of interest, one possible solution is to collect a set of conference proceedings in the general area, read all the papers that are

contained, and extract from this the information that is relevant to the targeted topic. As one might expect, this is not the most common way of doing research. Instead, the researcher will probably first read the titles of papers, then turn to the abstracts and references of those that seem especially interesting, and only give a close reading to the papers that are judged to be most relevant. At each step the proximal information that is gained can influence the search for more distal information that has not yet been examined.

The Scatter/Gather system (Cutting *et al.*, 1993) supports such a process. Scatter/Gather allows a user to browse large collections of text documents. The system begins by showing the user an automatic clustering of documents into a small number of clusters by analyzing the content of the documents in the collection, using standard information retrieval techniques. The user is presented with topical terms that are characteristic of each cluster. On the basis of this information, the user gathers those clusters that appear interesting into a selected set, whereupon the system can create a new set of clusters of this smaller set of documents to be examined. The process repeats until the user can choose specific documents to read.

Pirolli developed a cognitive model, called ACT-IF, to test the information-foraging model. ACT-IF is based on ACT-R and shares much of the same underlying conceptual structure. One novel extension to the ACT-R architecture is ACT-IF's reliance on a spreading activation network. In spreading activation, a network of concepts (or comparable cognitive structures) is maintained. When a specific structure is activated, this activation spreads to those related points to which the structure is connected. For example, activation of a structure corresponding to the concept of "government" might cause related concepts such as "legislature" and "judiciary" to be activated. Spreading activation has been effectively used as a model of association in human memory processing. On the basis of this memory model and production processing specific to information foraging, ACT-IF can provide simulations of how users navigate through collections of documents. ACT-IF has been validated in experimental studies against user performance in Scatter/Gather tasks and has demonstrated good correspondence with the way that users behave. This work shows the value of cognitive models in explaining how specific approaches to interaction with information technology are successful and by pointing developers in promising directions for future information systems.

### **Developing New Interaction Paradigms**

Over the past decade or so there has been increasing interest in agents for improving interaction with information technology. An agent is an autonomous or semiautonomous system that "can be considered by the user

to be acting as an assistant or helper, rather than as a tool in the manner of a conventional direct-manipulation interface” (Lieberman, 1995). Agents have the potential to be “aware” of a user’s habits, preferences, and interests; to behave proactively; and to adapt to the user’s specific interests and needs (Maes, 1994). Agents have begun to appear in help systems, scheduling assistants, scripting systems, intelligent tutoring systems, collaborative filtering applications, “matchmaking” applications, and electronic auctions.

Whereas most current agents rely on techniques developed in artificial intelligence and other areas of computer science, the notion of agents based on cognitive models of user behavior has great appeal. In some systems, for example, a model of the user’s knowledge is maintained and updated through the system’s observations of the user’s actions and decisions. In other systems, a model of user attention is maintained, so that the type and amount of information provided by the system are moderated by the system’s evaluation of the user’s cognitive load. Yet other systems interact with users in virtual environments, providing an embodied conversational agent to interact with users via natural language, gestures, and other nonverbal means of communication, even bringing personality and emotion into the interaction, in order to provide information that not only matches the user’s information needs but accounts for the context in which information is requested and used.

The most prominent example of the first approach to interaction can be found in the Cognitive Tutor project. The Cognitive Tutor simulates the ways that students think about problems in specific domains, such as mathematics, in order to guide and challenge the students in solving problems. Cognitive models within the system maintain a representation of individual students’ knowledge, solution strategies, and strengths and weaknesses. The Cognitive Tutor has been used by some 170,000 students and has resulted significant improvements in education and training.

Understanding the broader needs of users and the context of their tasks remains a challenge for cognitive modeling, but more “cognitive agents” are beginning to appear in many specialized information technology domains.

## **Conclusion**

There are a number of other approaches peripheral to cognitive modeling research that apply cognitive principles to interaction modeling. For example, Healey *et al.* (1995) have shown that the capabilities of human low-level visual processing can be harnessed by visualization systems, such that specific classes of patterns can be identified without the need for focused visual attention. In other words, in these visualizations, specific patterns “pop out” of the display, requiring next to no cognitive effort on the part of the user. In the area of cognitive work analysis, Vicente (1999) has demonstrated

the value of representations of work domains, worker competencies, and even social–organizational relationships toward building systems to support users in their work. In this research, as with all the projects discussed above, interaction with information technology is driven by cognitive concerns. The effectiveness of such systems will improve as we make further progress in cognitive science.

## References

- Anderson, J., and C. Lebiere. 1998. *The Atomic Components of Thought*. Mahwah, N.J.: Lawrence Erlbaum.
- Byrne, M. D. 2002. Cognitive architecture. In J. Jacko and A. Sears (eds.), *Human-Computer Interaction Handbook*. Mahwah, N.J.: Erlbaum.
- Cutting, D. R., D. R. Karger, and J. O. Pedersen. 1993. Constant interaction-time Scatter/Gather browsing of very large document collections. *Proceedings of SIGIR '93*.
- Gray, W. D., B. E. John, and M. E. Atwood. 1993. Project Ernestine: Validating GOMS for predicting and explaining real-world task performance. *Human Computer Interaction*, 8(3), 237–309.
- Healey, C. G., K. S. Booth, and J. T. Enns. 1995. Real-time multivariate data visualization using preattentive processing. *ACM Transactions on Modeling and Computer Simulation*, 5(3), 190–221.
- Hornof, A., and D. E. Kieras. 1997. Cognitive modeling reveals menu search is both random and systematic. In *Proceedings of the Conference on Human Factors in Computing Systems*, volume 1, 107–114. New York: ACM Press.
- John, B. E. and D. E. Kieras. 1996. The GOMS family of user interface analysis techniques: comparison and contrast. *ACM Transactions on Computer-Human Interaction* 3(4): 320–351.
- Kieras, D. E., and D. E. Meyer. 1998. The epic architecture: Principles of operation. Ann Arbor, Michigan: Artificial Intelligence Laboratory, University of Michigan. <ftp://www.eecs.umich.edu/people/kieras/EPIC/EPICArch.pdf>.
- Lieberman, H. 1995. Letizia: An Agent that assists Web browsing. *Proceedings of the International Joint Conference on Artificial Intelligence*, pp. 924–929.
- Maes, P. 1994. Agents that reduce work and information overload. *Communications of the ACM*, 37(7): 31–40.
- Newell, A. 1990. *Unified Models of Cognition*. Cambridge, Mass.: Harvard University Press.
- Pirolli, P. 1997. Computational models of information scent-following in a very large browsable text collection. In *Proceedings of the Conference on Human Factors in Computing Systems*, volume 1, pp. 3–10, Atlanta, GA. New York: ACM Press.
- Pirolli, P. 2003. Exploring and finding information. In Carroll, J. M. (ed.), *HCI models, theories, and frameworks*. San Francisco, Calif.: Morgan Kaufman.
- Pirolli, P., and S. K. Card. 1999. Information Foraging. *UIR Technical Report*. January.
- Ritter, F. E., G. D. Baxter, G. Jones, and R. M. Young. 2000. Supporting cognitive models as users. *ACM Transactions on Computer-Human Interaction* 7(2): 141–173.

- Rosenbloom, P. S., W. L. Johnson, R. M. Jones, F. V. Koss, J. E. Laird, J. F. Lehman, R. Rubinoff, K. B. Schwamb, and M. Tambe. 1994. Intelligent automated agents for tactical air simulation: A progress report. *Proceedings of the Fourth Conference on Computer Generated Forces and Behavioral Representation*. Orlando, Fla.
- St. Amant, R., T. E. Horton, and F. E. Ritter. 2004. Model-based evaluation of cell phone menu interaction. In *Proceedings of CHI '04 (ACM Conference on Human Factors in Computing)*, pp. 343–350
- Vicente, K. 1999. *Cognitive Work Analysis: Toward Safe, Productive, and Healthy Computer-Based Work*. Mahwah, N.J.: Lawrence Erlbaum.

## 14. COGNITIVE TECHNOLOGIES

*William Sims Bainbridge, National Science Foundation<sup>1</sup>*

*Abstract:* Over the course of history, cognitive technologies have been implicated in religious debates and have been retarded by the lack of proper cognitive science and information technology. Today, information technology permits the development of many new cognitive technologies, assisted when appropriate by biotechnology and nanotechnology. Two illustrative applications are 1) an artificial intelligence personal advisor, and 2) dynamic lifetime information preservation systems. Of necessity, cognitive technologies are often more personal than other kinds of technologies, and thus they require a shift in the focus of cognitive science to give greater emphasis to the understanding of each unique individual and his or her intimate social context.

### Introduction

Since the dawn of history, human beings have sought to understand and to command their world. Archimedes is reputed to have said that he could move the world, if he had a lever long enough and a fulcrum strong enough. That lever is Converging Technologies, and the fulcrum is Converging Sciences.

Many perceptive observers have noticed the progressing convergence. In his massive study of the Information Society, Manuel Castells writes, “Technological convergence increasingly extends to growing interdependence between the biological and micro-electronics revolutions, both materially and methodologically. . . . Nanotechnology may allow sending tiny microprocessors into the systems of living organisms, including humans” (Castells, 2000: 72). In his influential book, *Consilience*, Edward O. Wilson (1998; cf. Dennett, 1995) wrote about the rapid unification of scientific knowledge that is taking place today, and he wondered whether the natural sciences would be able to unite with the humanities and religion that traditionally have claimed to understand humanity itself.

To move the Earth, Archimedes recognized, one needs a cosmic place to stand. To move the human mind, it was long thought, requires a transcendent standpoint. But today the mysteries of the mind are gradually being unraveled by a multidisciplinary movement called cognitive science, and the groundwork is being laid for a host of technologies based in its discoveries.

---

<sup>1</sup> Any opinions, findings, and conclusions or recommendations expressed here are those of the author and do not necessarily reflect the views of NSF.

Earlier in the brief history of the Converging Technologies Movement, the nano-bio-info triad was referred to as technologies, whereas the cognitive area was described as a science (Roco and Bainbridge, 2003). Really, there are both sciences and technologies in all four areas – nanoscience as well as nanotechnology, for example – and convergence will require both fundamental research and applied engineering. Cognitive science is itself a relatively new field formed through the convergence of smaller disciplinary fragments, and perhaps only now is it really accurate to say that well-grounded cognitive technologies exist.

Cognitive technologies are science-based methods for augmenting or supplementing human knowledge, thought, and creativity. In the coming decades, they will benefit greatly from convergence with the three other domains of knowledge and capability. From biology and biotechnology, they will gain a constantly improving understanding of the human brain, psychiatric and normal-enhancing medications, and a systematic appreciation of affective cognition and emotional intelligence. From information science and infotech will come databases (bioinformatics, nanoinformatics, etc.), new tools for communication with other human beings, and artificial intelligence to gradually supplement (but never supplant) the power of our own minds. From nanoscience and nanotechnology will come the methods needed for brain research, sensors for capturing new kinds of information about the environment, and the nanoscale components required for truly mobile information processing. Cognitive technologies, in return, will offer the other domains new ways to conceptualize and communicate about their realms of reality.

### **The Prehistory of Cognitive Technologies**

Just as some of the accomplishments of chemistry were achieved centuries ago, such as the creation of steel by ancient metallurgists and concrete by Roman builders, some cognitive technologies date from bygone times. One could argue that counting, a practice we take thoroughly for granted, was one of the first and most effective cognitive technologies, followed by simple arithmetic, and then by the sophisticated geometry of the ancient Egyptians, Babylonians, and Greeks. Writing could certainly be described as an ancient cognitive technology, although it appears to have been based on precious little linguistic science. Whatever developments of the ancient world we would like to count as pioneering cognitive technologies, previous civilizations lacked real cognitive science, and thus easily went astray in the search for ways to improve the human mind.

Cognitive technologies augment the capabilities of the human mind, and thus they require a proper understanding of how the mind works (Pinker, 1997). For most of human history, this understanding was lacking, and



people possessed a whole menagerie of illusions about themselves. Too much investment of hope and resources in cognitive technology, before a true understanding of the mind has been achieved, is disastrous. It not only wastes effort but inhibits progress in other areas of science and engineering. Long before science could frame successful theories of reality, religion convinced people that it did so, both because faith offered hope and because supernatural claims are not easily refuted empirically (Stark and Bainbridge, 1987).

Ancient Egypt is famous for its early technological development, represented not only by the great pyramids but also by the fruitfulness of its agriculture, advances in medicine, and apparently the independent invention of writing. There may be many reasons why Egyptian progress essentially stalled soon after the pyramids were built, but one may have been the development of religious technologies of immortality, including cognitive technologies.

No one today believes that mummification and the associated rituals actually grant the individual immortality, but for the ancient Egyptians, elaborate preparation of the dead body transformed it into a proper vehicle to transport the soul to the afterlife (Budge, 1964; Taylor, 1966; Leca, 1981; David and Tapp, 1984). Indeed, the Egyptians had a very complex theory that the human personality was a collection of separable parts that needed to be reassembled after death. The ritual called “opening the mouth” was intended to insert part of the spirit back into the body. By one estimate, the sands of Egypt hold 100,000,000 mummified bodies, and vast wealth was poured onto those sands in a vain attempt to live forever. In consequence, both less material wealth and less human talent were available for more realistic fields of science and engineering.

A comparable problem has plagued Asian societies. Variants of Hinduism, Buddhism, and other oriental religions practice what might be called spiritual magic. Through rigorous meditation, yoga exercises, and numerous rituals, people seek to gain enlightenment and transcendent powers. These could also be described as technological religions that believe they can transform the human spirit through carefully controlled effort. Again, the result is to drain talent and investment away from more realistic technologies and to impose upon the society ideologies that inhibit real progress. Not all Asian faiths directly encouraged magical thinking; Confucianism, which was chiefly an elite ethical code, did not. However, most people in Asian societies participated in multiple religio-magical traditions simultaneously, unlike the situation in the Judeo-Christian-Islamic tradition, where one or another faith has often achieved a near monopoly over others in a particular society.

For a century, sociologists like Max Weber (1958) have argued that a decisive historical characteristic of Christianity was its suppression of magic.

Of course, Christianity is diverse and has known many heresies over the centuries, but its mainstream has relied upon the divine being, Jesus Christ, to save souls, rather than upon methods practiced by mortals. People can lead righteous lives, and they can pray for God's help, but Christianity does not encourage believers to learn techniques designed to improve their souls, minds, or personalities. Especially after Protestantism downgraded monasticism and the priesthood, Christianity has left secular science and engineering free to explore and master the real world, which they have done with great and continuing success.

In the 20th century, however, the groundwork for realistic cognitive technologies was laid by the establishment of psychology as an academic discipline, the emergence of neurobiology, and the first primitive steps in the development of artificial intelligence. Psychoanalysis and the swarm of psychotherapies that arose were probably a false start in the founding of real cognitive technologies, but they evidenced the pent-up demand for cognitive technologies that exists in modern society. Unfortunately, they were not based either upon a solid tradition of prior scientific research, nor upon careful studies of their own effectiveness.

Today we stand at the threshold of a true understanding of how the human mind works. Optimist that I am, I think we may have a full understanding by the end of the 21st century, but even if it takes us another two centuries rather than one, we already understand much. Now, for the first time in human history, effective cognitive technologies based on solid scientific research are possible and have begun to appear. The first applications may be modest, and they will certainly not confer immediate immortality or a freedom from fear, confusion, and sin, but they will enhance our lives and feed back into the process of scientific-technical development to achieve still more progress.

Unfortunately, the transition will be painful for many people, as we have to deal with the fact that we still believe in many illusions inherited from previous centuries and millennia. Table 1 lists some of the past and present areas in which scientific enlightenment may require religious disillusionment. The Western religious traditions that protected us from the folly of supernatural cognitive technologies did so by means of counteractive superstitions. Some scholars argue that science and technological development are rooted in Western religious traditions (Westfall, 1958; Merton, 1973), yet none can deny that science and religion have existed in a tense relationship. For two reasons, that relationship may erupt into over conflict during this century.

First, the heart of Christianity is a special conception of the nature of a human being. Much is made of the Christian conception of God, a loving but demanding creator mysteriously manifesting as a trinity, who has the power to intervene in individual lives but gives humans considerable freedom. Less

is said about the Christian theory of the human mind, but it may be even more important. The doctrine of the immortal soul is notable not only for the concept of immortality but also for conceptualizing a person as a spiritual and moral unity that transcends the material world. The emergence of psychiatry in the nineteenth century raised the issue of how to reconcile this conception with the demonstrable fact that injury to the brain could cause radical changes in personality and behavior (Ray, 1863, 1871). The modern conception of the brain as a distributed neural network organized in complexly interconnected modules, in which thoughts and memories are lodged in physical structures, could hardly be more different from the notion of a transcendent soul (Pinker, 1997; Stein and Ludik, 1998; Quinlan, 2003; Schultz, 2003; Bloom, 2004). The gradual but constant progress of artificial intelligence is likely to challenge the traditional religious viewpoint ever more decisively in the coming years.

**Table 1: History of Disillusioning Innovations**

<b>Approximate Dates</b>	<b>Scientific or Technological Innovation</b>	<b>Enlightenment (Disillusionment)</b>
13th to 18th centuries	Mechanical clock, other machines	Complex behavior does not require spirit
16th to 20th centuries	Copernican Revolution: Discovery of a vast, centerless universe	Humanity is not relevant to most of the universe
19th and 20th centuries	Darwinian Revolution: Evolution by natural selection from random variation	Creation does not require a creator
20th century	Nuclear physics, quantum cosmology, mathematics of consistency	Physical existence is not free of paradox and uncertainty
20th and 21st centuries	Neurobiology of human brain; artificial intelligence; cognitive science	Humans lack souls, have limited cognitive integrity
21st century	Converging sciences and technologies	Closure of gaps in our knowledge where superstition could hide

Second, an implicit, centuries-long truce has existed between science and religion, based not only on science’s willingness to stay out of religion’s home territory but also upon the high degree of specialization in science. An individual scientist could be religious, despite his knowledge of facts in his own area of expertise that contradicted traditional religious beliefs, because he could ignore the secularizing influence of all the other separate branches of science about which he knew little. By bringing the sciences and technologies together, convergence will leave little room for faith. By presenting a comprehensive model of reality, science will leave religion little

scope to exist. The result could be an estrangement between religious and secular groups in society. However, technological convergence will mean that everybody uses the benefits of science and thus will have more reason to believe in it than in ancient myths left over from a primitive age in which kings ruled society, so people imagined the universe must also have a king.

The dominant social-science theory of religion, developed by a number of researchers including Rodney Stark, Roger Finke, and myself (Stark and Bainbridge, 1985, 1987; Stark and Finke, 2000; Bainbridge, 2002a, 2003b), derives faith in the supernatural from the fact that the natural world does not provide humans with all the rewards they desire. In the absence of a highly desired reward, such as eternal life, humans will accept beliefs that “posit attainment of the reward in the distant future or in some other non-verifiable context. . . . Compensators are postulations of reward according to explanations that are not readily susceptible to unambiguous evaluation. . . . [Religions are] systems of general compensators based on supernatural assumptions” (Stark and Bainbridge, 1987: 35–39). Before most people will be willing to forsake religious faith, science and technology will need to compensate them for their psychological loss both by providing an array of exceedingly valuable new technological rewards and by offering a personal science that cherishes and celebrates the uniqueness of the human individual.

Cognitive technologies are already entering our lives. The revolution has begun with humble tools like the spell checker in our computer’s word processor, or the search engines we use to find our way on the World Wide Web. As the technology changes, we also will change, as we have done so many times in the past when our own creativity has transformed the nature of our lives. Hopefully, cognitive technologies can improve human life sufficiently, that wishful thinking will no longer be necessary. Ancient religions served humanity long and sometimes well, but now we must abandon them as we follow the biblical directive of John 8:32: “And ye shall know the truth, and the truth shall make you free.”

Progress may not be easy. Decades ago, computer scientists were too optimistic about how easy it would be to develop artificial intelligence, for example (Crevier, 1993). We now understand that we are nowhere near ready to duplicate the full complexity of human intelligence. The aim now is not to supplant human intelligence but to supplement it. Rather than building humanoid robots that walk and talk like people, we are building massive information systems to serve people, mobile computers to accompany people wherever they go, and human computer interfaces to maximize the comfort and usability of the systems (Bainbridge, 2004a). We will now consider two examples, cognitive technologies that stress the personal nature of personal computing, plus an example of how these technologies feed innovation back to enhance science.

### **ANNE: Analogies in Natural Emotion**

I will now describe a specific project illustrating how the cognitive technological developments of the next few years can be simultaneously radical and somewhat limited in practical scope. The goal, in terms of human benefit, is a computerized system that can help a person think through his feelings about decisions he faces. It does so by means of analogies based on the emotional structure of the individual user's mind but also rooted in the categorization of emotions by the culture of which the individual is a part. I have created a working demonstration that I call ANNE – Analogies in Natural Emotion – a highly personalized computer database system that simulates a private advisor, psychotherapist, or spiritual guide.

First, I describe one of the ways in which the system can be used, then once we have a picture of ANNE, I explain the research and engineering required to create her. In her current form, ANNE is programmed to run on a tablet computer, a portable machine like a PDA but larger, simply because this kind of machine is a nice platform for demonstrating her utility. However, the software also runs on desktops or laptops and could easily be adapted for pocket or wearable computers.

Imagine you find yourself facing a challenging situation, such as, for example, giving a speech to a large and potentially critical audience. You would like to remind myself about similar situations you have handled in the past, for any one of several motivations. Perhaps you want to get in touch with your true feelings at this moment, and imagining similar occasions may help bring your emotions out. Or perhaps you want to bolster your courage and perhaps also remind yourself of tactics or strategies that worked well in the past and might be helpful now. You take out ANNE and go to the first data input page. Here you write a very brief description of the situation. Perhaps you write: "lecturing to a critical audience."

Next you go to the second data input page, where you use 23 different measurement scales to record your feelings about the situation. Twenty of these involve the following emotions: Anger, Boredom, Desire, Disgust, Excitement, Fear, Frustration, Gratitude, Hate, Indifference, Joy, Love, Lust, Pain, Pleasure, Pride, Sadness, Satisfaction, Shame, and Surprise. For each of these, you take the stylus of the computer and click a radio button on a scale from 1 to 8, indicating how much the situation makes you feel a particular emotion. Perhaps speaking in public makes you feel 5 on the 1 to 8 Anger scale, 2 on the 1 to 8 Boredom scale, and so on to 7 for Shame and 6 for Surprise. Whatever your emotional reactions are, you enter them.

The remaining three scales also have eight steps each and ask you to judge the situation in terms of the three dimensions of how good, active, and strong it is. These are the three dimensions of the semantic differential system for measuring affective meaning, developed years ago by the

psychologist Charles Osgood (Osgood *et al.*, 1957, 1975; Bainbridge, 1994; Lively and Heise, 2004).

Once you have entered these 23 personal judgments of the situation, you click the Get Analogies button, and the computer lists for you a number of other situations that you feel most similarly about. ANNE starts out with 2,000 situations stored in her memory, but each new situation becomes part of the database and might come up again later on, in response to an even newer situation.

ANNE encourages you to think about how your current situation compares with the ones she says are most similar in terms of how you feel about them. For example, consider the emotionally evocative stimuli that ANNE reported were most similar to “lecturing to a critical audience,” for the first research subject to try the system: locking yourself out of your car, horses galloping, someone intentionally irritating you, going to a dentist, losing all your material possessions, being unable to control a vehicle you are driving, getting bad news, discovering that your home has been vandalized, a group of people running toward you, nagging, someone shouting at you, missing an appointment, a dentist drilling your tooth, conflict with a strong-willed person, being screamed at, the strong oppressing the weak, riding a roller coaster, being punched hard in the stomach, an attack by wild people, thunder, and undergoing great stress.

Few of these stimuli appear cognitively similar to “lecturing to a critical audience,” but they describe a group of emotional themes that appear to be powerful for this respondent: helplessness, being a victim, being overpowered by other people, being incompetent or out of one’s depth. This, ANNE suggests, is what “lecturing to a critical audience” really means for this person. A different user might have very different associations.

If you were using ANNE, you would consider what these most similar emotional stimuli have in common. Do any of them remind you of times in the past when you found a particularly successful way of dealing with the situation that ought to be tried again now? Do any of those past situations give you a fresh insight about how you ought to feel next? Do they give you the words with which to discuss your situation profitably with other people? Thus, ANNE does not authoritatively tell you what to do but enters into a dialogue with you, based on her intimate understanding of your personal feelings, that could help you come to your own happy resolution of the challenge you face in your current situation. In her finished form, ANNE could have many bells and whistles – optional features and modes of analysis – but it will be useful now to consider how she operates.

The scientific literature on emotion is strewn across many different fields: psychology, sociology, anthropology, linguistics, and neurobiology among others. Convergence of these fields has not yet taken place, so a comprehensive, reliable model of emotion is not yet available (Zajonc, 1998).

However, it is already possible to begin building applications that draw on conjunctions of some fields, and ANNE relies upon methods derived from psychology, sociology, and information science.

To begin with, the World Wide Web was used to assemble a large number of verbal stimuli describing situations that the ambient culture believes elicit a range of emotions (Bainbridge, 2000, 2002b, 2002c, 2003a, 2004b, 2004c). A project called The Question Factory posted questionnaires on the Web, in order to collect material from a broad range of people that could be used to create new questionnaire measurement instruments. Two Web-based questionnaires each listed 10 common emotions and asked respondents: “For each of these ten emotions, we will ask you to think of something that makes you have that particular feeling. By ‘things’ we mean anything at all – actions, places, kinds of person, moods, physical sensations, sights, sounds, thoughts, words, memories – whatever might elicit this emotion. We will also ask you to think of what makes someone else – a person very different from you – have the same feelings.”

The questionnaires gave respondents spaces to write “one of the things that might produce an emotion, whether in you or in somebody else.” Hundreds of people responded to these surveys, and I edited 1,000 stimuli from what they wrote. The 1,000 other stimuli came from 20 searches of the World Wide Web using various search engines to find texts describing situations that elicited each of the emotions. By this means, a large number of works of literature and online essays were located that used the words in context. Each of the stimuli in this set was written on the basis of the entire context around the quotation, although in many cases the phrase is a direct quotation. Thus the 2,000 stimuli describe situations that realistically would generate the given emotion in some people, whether or not they would in you.

The 2,000 stimuli were then written into a simple computer program for administering the items on a pocket computer. A research subject carried this computer for months and at convenient moments would rate the items on the 23 scales. A year earlier, the respondent had already rated them on the bad–good scale, so the stability of these judgments over time could be assessed, and on a scale that evaluated how well each would elicit the particular emotion to which each was connected. This process produced  $25 \times 2,000 = 50,000$  data points concerning the respondent’s emotional reactions that then were built into ANNE.

Figure 1 is a graph consisting of a histogram created automatically by ANNE, comparing “lecturing to a skeptical audience” with the 2,000 other situations in terms of their emotional qualities, expressed as z-scores above or below the mean. Note that the respondent feels “lecturing to a skeptical audience” is relatively frustrating, shameful, disgusting, and productive of anger, fear, and excitement.

Currently, ANNE contains just the data from that one respondent, but a commercial version could contain the responses of 100 or more respondents, both to provide a representative baseline of the population at large and to identify individuals who are especially similar to the user. The user could rate the 2,000 stimuli against the 25 scales, step by step over time, also adding new stimuli and developing a very rich personalized database. At this point, ANNE would be not merely a well-calibrated personal advisor for the particular user but also a time capsule of the user's feelings and personality that could be valuable as a memorial for future generations and a corpus of data for cognitive research.

**Figure 1. Histogram of Emotional Responses**

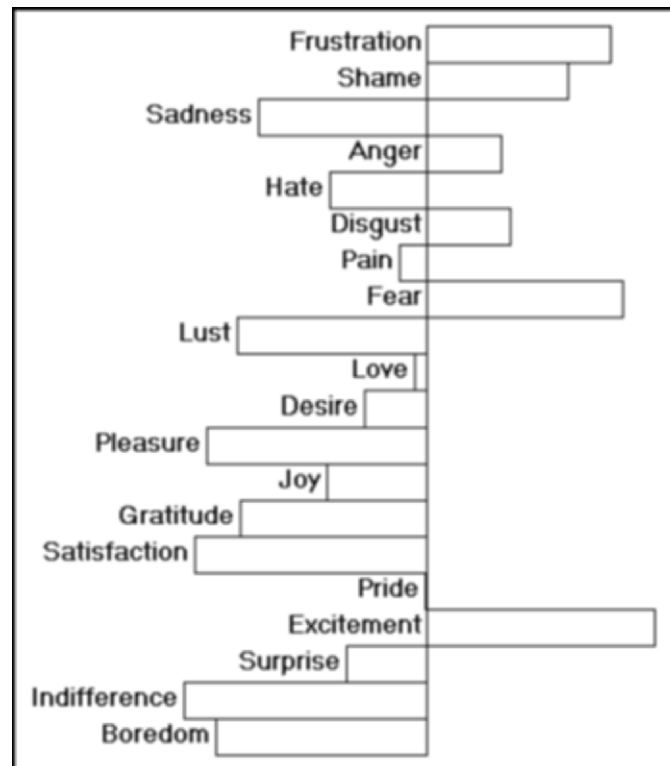

### **Idiographic Cognitive Research**

Research on human beings that seeks to establish broad generalizations applicable to all or to the majority of people is sometimes called nomothetic. The alternative is idiographic research intended to achieve understanding of a particular individual (Pelham, 1993; Shoda, *et al.*, 1994). Idiographic research is particularly connected to the work of the psychologist Henry



Murray (1981) but was common during the height of the psychoanalytic movement in the middle of the 20th century (e.g., Smith *et al.*, 1956). Today, literature (biographies, novels, literary criticism, and even poetry) seems to hold a near-monopoly on the study of individuals, thus locating this field within the humanities, rather than the sciences. The development of cognitive science holds the promise to return idiographic research to its proper scientific home, perhaps facilitating convergence between the humanities and sciences.

An application like ANNE collects vast information about a particular individual that can then be the basis of idiographic research, potentially combined later on with data about many other individuals to achieve nomothetic research at a new level of specificity and finer granularity. For example, the data already described can be used to map the particular individual's conceptions of how the 20 emotions relate to each other. The words describing the emotions, plus a wealth of ideas about the nature of emotions, are provided by the culture. Presumably, the genetically inherited structure of the human body and its nervous system also affect the ways we conceptualize emotions, and there remains room to debate how much emotions are rooted in physiology instead of being culturally constructed. But there will also be individual differences, whether described in terms of the personality of the individual or the uniqueness of the individual's cognitions.

Table 2 reports the results of an exploratory factor analysis of the 20 emotions for our individual respondent. (This particular analysis used the principal components method, extracting factors with eigenvalues greater than 1, and varimax rotation.) Factor analysis begins with a correlation matrix, in this case the  $(20 \times 19)/2 = 190$  correlation coefficients between all pairs of emotions, based on the respondent's 2,000 ratings for each emotion. Factor analysis is a data-reduction technique that produces a smaller number of new coefficients, similar to correlations, called loadings on the factors. A factor can be conceptualized as a new variable that sums up the variation in a group of the original variables, or it can be conceptualized as a dimension along which all the original variables can be arranged. This particular analysis produced three such factors.

Factor 1 has strong positive loadings on eight emotions that could be described as negative, and negative loadings on some emotions that might be described as positive. Thus, this factor represents negative affect or unpleasant emotions. In contrast, Factor 2 loads exclusively on the positive or pleasant emotions and can be called positive affect. In factor analysis, it is fairly common to find two factors that seem to be the opposites of each other, even though the method ideally distinguishes factors that are unrelated (orthogonal). This tends to happen when one very powerful dimension runs through the majority of variables. Also, as the concept of ambivalence

suggests, it is possible for people to have somewhat different conceptualizations of the positive and negative ends of a dimension, not perceiving them entirely as perfect opposites of each other. Factor 3 is rather distinct, chiefly reflecting two pairs of opposites: excitement–boredom and surprise–indifference.

**Table 2: Factor Analysis of 20 Emotions (factor loadings)**

	<b>Factor 1</b>	<b>Factor 2</b>	<b>Factor 3</b>
<b>Negative</b>			
Frustration	<b>0.80</b>	0.07	−0.11
Shame	<b>0.80</b>	−0.01	0.07
Sadness	<b>0.78</b>	0.01	0.05
Anger	<b>0.72</b>	−0.25	0.13
Hate	<b>0.67</b>	−0.32	0.12
Disgust	<b>0.66</b>	−0.20	0.05
Pain	<b>0.64</b>	−0.17	0.36
Fear	<b>0.59</b>	−0.16	0.54
<b>Positive</b>			
Lust	0.03	<b>0.81</b>	0.07
Love	−0.28	<b>0.80</b>	0.06
Desire	0.20	<b>0.79</b>	0.20
Pleasure	−0.39	<b>0.73</b>	0.08
Joy	−0.57	<b>0.63</b>	0.17
Gratitude	−0.40	<b>0.61</b>	0.07
Satisfaction	−0.62	<b>0.55</b>	0.20
Pride	−0.59	<b>0.46</b>	0.24
<b>Energetic</b>			
Excitement	−0.02	0.29	<b>0.80</b>
Surprise	0.01	0.09	<b>0.76</b>
Indifference	−0.17	−0.18	<b>−0.68</b>
Boredom	0.06	−0.02	<b>−0.78</b>

Osgood's semantic differential, mentioned earlier and also incorporated in the data set, is a classical theory and measurement system for affective meaning. In a vast, international research program culminating in the 1970s and influencing work by successors even today, Charles Osgood identified three primary dimensions of variation that could be measured by dichotomous scales: good–bad, active–passive, and strong–weak. Some critics suggested that only the first one, good–bad, was really significant, and for our particular respondent there seems to be some truth in that judgment.

For this respondent, 16 of the 20 emotions are powerfully associated with either positive or negative affect. The remaining four emotions may reflect a conception of high or low energy, unrelated to good–bad, in this respondent’s mind. Table 3 clarifies this by examining correlations between the 20 emotions and four semantic differential variables.

**Table 3: Semantic Differential of 20 Emotions (Correlations)**

	<b>Good 2001</b>	<b>Good 2003</b>	<b>Active</b>	<b>Strong</b>
<b>Negative</b>				
Frustration	-0.38	-0.48	-0.22	-0.23
Shame	-0.40	-0.50	-0.14	-0.17
Sadness	-0.37	-0.49	-0.16	-0.17
Anger	-0.48	-0.58	-0.01	-0.05
Hate	-0.49	-0.59	-0.01	-0.05
Disgust	-0.44	-0.56	-0.16	-0.19
Pain	-0.39	-0.50	0.02	0.02
Fear	-0.41	-0.47	0.13	0.10
<b>Positive</b>				
Lust	0.31	0.38	0.10	0.14
Love	0.50	0.59	0.14	0.20
Desire	0.22	0.28	0.07	0.13
Pleasure	0.50	0.66	0.17	0.19
Joy	0.60	0.76	0.27	0.34
Gratitude	0.50	0.57	0.12	0.17
Satisfaction	0.59	0.77	0.28	0.35
Pride	0.53	0.68	0.30	0.38
<b>Energetic</b>				
Excitement	0.11	0.21	0.45	0.48
Surprise	-0.01	0.06	0.31	0.27
Indifference	0.03	0.00	-0.23	-0.24
Boredom	0.01	-0.08	-0.38	-0.35

The respondent rated the 2,000 stimuli twice in terms of good–bad, with a 2-year gap of time between them. The second set of ratings came from the same months in which the respondent did the emotion ratings. Thus, we see that the correlations with the negative and positive emotions are universally stronger in the second column of Table 3 than the first. This should not be misunderstood. For example, the fact that the correlations for frustration rises from 2001 to 2003 does not mean that the particular respondent necessarily

has become more frustrated but, rather, that the particular pattern of which stimuli the respondent considers good has changed over the intervening 2 years. Thus, with care, data of this sort collected over time can be used to examine the dynamics of the individual's personality and cognitions, not just their static structure at one point in time.

This particular respondent does not seem to distinguish two of the semantic differential scales, active–passive and strong–weak, that usually are distinguished clearly in studies asking a large number of people a small number of questions. The correlations between these two scales and the four items in Factor 3 are almost identical. Keep in mind that each of these correlations is based on fully 2,000 pairs of measurements, and thus is statistically quite solid. It is very unusual in sociology, psychology, or social psychology to have so many data points for one individual, and social scientists are not accustomed to calculating correlations within a single individual. That, of course, is the whole point of this endeavor in idiography, to introduce a new approach that alters the relationships between the person, the data, and the research methodology. It may be that many kinds of significant interpersonal differences, perhaps reflecting fundamental cognitive processes, have been overlooked in past conventional research, because of the dearth of data about any single individual.

### **Dynamic Lifetime Information Preservation**

The emergence of digital libraries in the 1990s (Lesk, 1997) and the near universality of home computers suggest that ordinary individuals will soon possess personal digital libraries representing their entire lives and full range of interests. In modern society, individuals produce many records of their thoughts, feelings and actions – some as intentional mementos, but most simply as byproducts of their ordinary activities. A shadowy image of an individual can be found in diaries, letters, published writings, news clippings, official documents, photographs, movies or videotapes, sound recordings, physical measurements, clothing and artifacts, familiar environments, and the memories of other people. These artifacts, and the environments in which people live, play essential roles in their cognitive life. Thus, much can be learned by amassing evidence of these kinds.

In order to simulate my own thinking about the range of sources that can inform biography, I have recently surveyed all the kinds of data that exist concerning my paternal grandfather, Dr. William Seaman Bainbridge, forming a kind of pilot project seeking analogies for new methods of charting a life and personality. Considering himself a scientist as well as being an internationally famous surgeon (Bainbridge, 1914), my grandfather is remarkable for the many ways in which he diligently tried to get himself into the historical record, and the wide array of media he used to record his

thoughts or other aspects of himself. Around 1890, he became a friend and disciple of Dr. Jay Seaver (1892), a founder of physical anthropometry – the science of measuring human beings – and actively tried out all the instruments in Seaver’s laboratory: calipers, scales, dynamometers, and templates to trace the contours of spines.

My grandfather’s hundred or so scientific papers have an aspect of autobiography, because they typically describe medical cases he himself examined and treated. Many of his books are reports of international medical conferences he helped organize (e.g., Bainbridge, 1922, 1925). The first extant publications about him are newspaper articles dating from his boyhood in the 1870s and 1880s, and his actual death scene in 1947 is depicted in a book by his close friend Norman Vincent Peale (Peale and Blanton, 1950: 200–202). The earliest still photograph of him dates from 1873, and the earliest motion picture is from 1929. Recordings of his voice have unfortunately been lost.

Two related questions spring from such an informal examination of the vast surviving corpus of information about an individual: 1) How do we organize all the multimodal sources so that the connections between them become most apparent; that is, how do we weave the fragments of a life back into the meaningful fabric of existence that it was for the person? 2) How do we correctly infer the mind of the person from the effects of their behavior – how do we reconstruct the thought processes that define his distinctive cognitive style? The first of these would find its answer in information science, and the second in cognitive science, so together they require scientific and technological convergence.

A large number of major research projects, some of them supported by the National Science Foundation (NSF) and others by agencies like the Defense Advanced Research Projects Agency (DARPA), plus corporate-funded projects, are intentionally or unintentionally developing the technology to deal with the issues effectively in the near future. I here describe a few of the most prominent projects, alternating with observations derived from the pilot project of trying to make sense of my grandfather’s intellectual legacy, to suggest the possibilities that lie ahead.

Professor Howard Wactlar at Carnegie Mellon has been a pioneer in developing computerized systems for documenting the stream of a person’s experience and rendering its themes and specific content accessible for other people. His Informedia Experience-on-Demand Project explains on its Web site that it “develops tools, techniques and systems allowing people to capture a record of their experiences unobtrusively, and share them in collaborative settings spanning both time and space.”<sup>1</sup> The online abstract of Wactlar’s related, NSF-funded project, “Capturing, Coordinating and

---

<sup>1</sup> [www.informedia.cs.cmu.edu/eod/](http://www.informedia.cs.cmu.edu/eod/).

Remembering Human Experience” (NSF award 0121641), lists four chief goals of his research:

- Enhanced memory for individuals from an intelligent assistant using an automatically analyzed and fully indexed archive of captured personal experiences
- Coordination of distributed group activity, such as management of an emergency response team in a disaster relief situation, utilizing multiple synchronized streams of incoming observation data to construct a “collective experience”
- Expertise synthesized across individuals and maintained over generations, retrieved and summarized on demand to enable example-based training and retrospective analysis
- Understanding of privacy, security, and other societal implications of ubiquitous experience collection.

Commercial tools for organizing the information output of a lifetime are already under development. As part of a Microsoft research project, called MyLifeBits, computer pioneer Gordon Bell has scanned into a computer all his own accumulated articles, books, cards, CDs, letters, memos, papers, photos, pictures, presentations, home movies, videotaped lectures, and voice recordings (Bell and Gray, 2001).<sup>1</sup> New information, such as telephone calls and e-mail messages, can be captured digitally in real time. The Franklin D. Roosevelt Presidential Library and Museum, in cooperation with Marist College and IBM, is building an online archive of FDR’s papers, already including much of his private diplomatic correspondence (with the Vatican, Britain, and Germany) and transcriptions of the “fireside chats” with which he rallied a distressed nation over the radio.<sup>2</sup>

Several projects are producing digital replicas of existing or historical environments, thereby developing the systems that ordinary people of the future will need to virtualize their homes, schools, and workplaces so they can revisit them whenever they want throughout their lives. The Institute for Advanced Technology in the Humanities of the University of Virginia has produced a virtual recreation of the Crystal Palace from the great London exposition of 1851.<sup>3</sup> The Art History and Archaeology Department at Columbia University is virtualizing the Amiens Cathedral.<sup>4</sup> The standard approach, also employed in many video and computer games, is to create a

---

<sup>1</sup> [research.microsoft.com/barc/mediapresence/MyLifeBits.aspx](http://research.microsoft.com/barc/mediapresence/MyLifeBits.aspx).

<sup>2</sup> [www.fdrlibrary.marist.edu/](http://www.fdrlibrary.marist.edu/).

<sup>3</sup> [www.iath.virginia.edu/london/model/](http://www.iath.virginia.edu/london/model/).

<sup>4</sup> [www.mcah.columbia.edu/Amiens.html](http://www.mcah.columbia.edu/Amiens.html).

three-dimensional “wireframe” outline of the basic structure of a building, then drape it with surfaces having the appropriate colors, textures, and detail.

A somewhat different approach draws upon the hypertext or link idea from the World Wide Web to link together a number of photographs and pieces of information (often called metadata) describing them, which may or may not be assembled as well into a virtual environment, depending upon one’s purposes. A person’s home is simultaneously a shaper and an expression of his or her personality. Figure 2 is an example from my pilot study of my grandfather’s data, showing some of the rooms in his apartment at 34 Gramercy Park at the foot of Lexington Avenue in New York City, a nine-story brick and red stone masterpiece completed in 1883, boasting a “magnificent foyer decorated with stained glass and Minton tiles” and topped by a turret (Garney, 1984: 148; cf. Kisseloff, 1989). Above the ground floor, the building encircled an inner court, and its ample awning-shaded windows drew in light from the south and west. On the outside, each storey was separated from the next by strips of a different carved design. Stone lions glowered above the entrance. The marble stairs carried iron banisters, and the thick interior brick walls had tin barriers against the mice.

Originally intended as a hotel, Thirty-Four was the first cooperative apartment house in New York. Unlike with a condominium, residents did not own the apartments they lived in, but in 1897 my grandfather purchased stock in the Gramercy Company, which owned the entire building. His office filled the south side of the ground floor, and his home was directly above on the “first floor,” counting stories in the European fashion. A hall ran 52 feet from front to back of the grand apartment, and a small bedroom off the kitchen ensured that the cook would always be near her duties. The building staff included a doorman, an elevator man, and two firemen in the basement who tended the central heating. A technological wonder of the age, the building possessed three hydraulic elevators, one of which opened into the kitchen at the back of the apartment. When documenting a residence, it is essential to include facts such as these, in as great a detail as practicable.

Figure 2 is a montage of four photographs. One shows my grandfather’s elder son (my father) taken in about 1930. The three other pictures date from about 1945. How parents wish to present their children in formal photographs can be very revealing, and the boy’s dramatic uniform reveals his military school training. As a simple example of how the hypermedia link concept can be applied to a set of photographs, I have drawn circles around key features, connected by lines to others. One links the face of the boy to an oil painting of him sitting in his mother’s lap from a decade earlier. A feature on the mantle is circled in his photograph, and the one to the right. A feature that appears in two or more photographs and is used to link them can be called a landmark or an anchor point. We see the same oil painting over the mantle in

**Figure 2. Assembling Photographs in Re-creating an Environment**

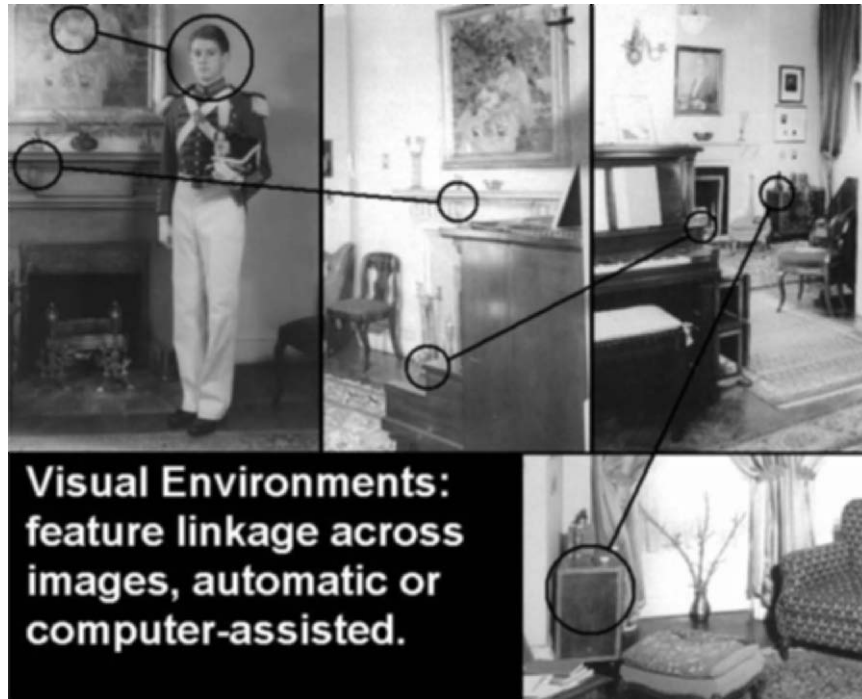

the second picture, but the objects on the mantle have changed. Another link connects a corner of the upright piano from one picture to another, and the top left edge of a cabinet links to another picture. These were among the most prominent rooms of the apartment, rivaled only by a formal dining room, but every room contained original works or art and artifacts brought back from overseas trips. Every normal human being places objects and artworks on display to express their character and status to visitors, as well as to provide pleasure for themselves, and documenting them is a step toward understanding that individual's personality.

Today, it is quite practical to photograph every wall of every room, and every object in each room, with automatic tags recording how the pieces fit together, in a matter of a few hours. Very shortly, we will have commercial software to re-assemble these pieces into virtual environments automatically. A major research project that is developing the fundamental principles for such systems is led by Peter Allen and Lynn Meskell at Columbia University, and is using the nearby Cathedral of St. John the Divine as a test case.<sup>1</sup>

For more than a century and a half, photographs have been an important medium through which people record their lives and express themselves, and

<sup>1</sup> [www.mcah.columbia.edu/divine/nsf.html](http://www.mcah.columbia.edu/divine/nsf.html).



for better than half that time, motion pictures have served these functions as well. Home movies can provide useful clues about personality, especially in those staged scenes when someone shows off a skill they possess. My grandfather's highest skill was surgery on the human body, and he hired professionals to take photographs of operations, make drawings of intestinal adhesions he discovered in his patients, and even construct more than 100 wax models of cancers he removed. But operating rooms are private places, and it would be indecent to display their images informally. At frequent dinners for guests, however, he got the opportunity to display his skill via transference to the similar task of carving the roast turkey, pork, or beef. Figure 3 is a montage of frames from a home movie of a visit of the 1932 Polish Olympic team to the farm he owned near Bethel, Connecticut, in which he demonstrates his skill on a watermelon.

**Figure 3. A Surgeon Showing Off with a Watermelon in 1932**



After more than 70 years, the excitement of the great watermelon surgery still lives. The film shows the Olympic team standing around, transfixed, watching the procedure. When the Polish official helps to open the watermelon, revealing a pair of perfect florets exactly the right size to be servings for the guests, the assembled throng bursts into applause. The surgeon bows, then waves the carving knife dramatically in the air, his pride evident in his beaming smile. However much we might want to reduce human personality to correlation coefficients and factor scores, such images capture essential qualities in a way that mathematical media cannot.

The original black-and-white home movie was made in 16 millimeter format in 1932, transferred to VHS videotape around 1990, and video-captured into a computer and digitized in 2004. Digital format allows one to annotate individual frames and combine the moving images with other media. Today, of course, home “movies” are often digital from their inception, and many homes now have convenient means for transferring still photos, movies, and sound recordings to and from computers and across multiple formats. Whereas film is expensive, digital media are cheap, and progress in nanotechnology is likely to achieve increasing quality at decreasing cost for a number of years to come.

Among the most impressive current research projects assembling both a virtual architectural recreation and moving images of people is Virtual Vaudeville, created by a team at the University of Georgia led by David Z. Saltz.<sup>1</sup> The aim is nothing less than to bring back to life vaudeville performances in New York’s Union Square Theater from 1895, complete with realistic animations of the acts and an audience that is as diverse and responsive as any my grandfather might have observed in real life. Avatars of specific performers are being created, such as strongman Sandow the Magnificent and ethnic comedian Frank Bush, using motion capture techniques from Hollywood and computer graphics methods from videogames. When the project is complete, the creators hope it will be possible for a person of today to enter the virtual reality as if they were a real member of the audience, interacting with those in neighboring seats, and encouraging the virtual performers with their real applause.

Before too very much longer, progress in information and cognitive technologies, supported by nanotechnology and occasionally by biotechnology, will make it possible to record, preserve, and virtualize many kinds of social environment. Alumni of a grammar school will be able to don virtual reality helmets wherever they are around the world and reenter their eighth-grade classroom together, half a century after they graduated. Social scientists will be able to observe the dynamics of social groups across vast distances of space, time, and institutional purpose – such as corporate committees, sports teams, and courtroom trials – and be able to replay them in virtual reality when they need to focus on an interesting exchange.

Databases about people should be linked together, just as human lives are linked in the real world. For example, the paragraphs in my grandfather’s book (Bainbridge, 1919) reporting front-line surgical methods on both sides of the Western front in World War I could be linked to the pages in his extensive diaries in which he wrote information down as he visited military hospitals, thereby revealing his thought processes while writing. Links could further go to archives for each of those hospitals, to the personal archives of

---

<sup>1</sup> [vvaudeville.drama.uga.edu/](http://vvaudeville.drama.uga.edu/).

the prominent surgeons and military officers who served in them, and potentially to biographies of the wounded who were treated in them. This requires dynamic relational computerized databases of interconnecting lifelines.

The potential applications are practically infinite. In the future, a psychotherapist and her client will be able to visit the client's home for dinner, in the past, when the client was a child, and re-experience from an adult perspective the forces that may have distorted the client's personality. Students will be able to visit the studio of a great artist, observing him paint and interact with his apprentice, halfway around the world or decades after the artist died.

A collection of information objects representing a person's life should include artifacts and multimedia, fully digitized in two, three, and four dimensions, fully annotated with metadata, fully linked as hypermedia to the other items. Dynamic Lifetime Information Preservation can preserve the lifetime experiences of a person, support research on individual cognition and emotion, and build a network of AI-vitalized virtual communities – a cybernation. Its achievement requires new industries based on Converging Technologies, and it offers new tools for science and personal enhancement.

## **Conclusion**

Cognitive Technologies will enhance human memory, decision-making, creativity, and emotional response. They will be achieved by convergence of nanotechnology, biotechnology, and information technology with cognitive science. There is also the potential for convergence with the social sciences and the humanities, if the competition with religion does not become so strenuous as to fracture the culture in half – one side oriented toward science and the other toward superstition. The fact that a science of human emotion is beginning to emerge in conjunction with cognitive science suggests that a fully convergent science could compete effectively with religion and could unite with the arts.

The convergent creation of cognitive technologies will be achieved both by gradual development of hundreds of modest applications and by occasional unexpected breakthroughs. It will transform our conception of ourselves, thus debunking old illusions while enabling new dreams. It will call into question traditional norms of privacy, individuality, and group identity. It will be personal in a sense that other technologies have never been, because we will perform research on ourselves in order to augment or even transform ourselves.

The new opportunities we face at this moment in the history of science are illustrated by applications such as the artificial intelligence personal advisor and dynamic lifetime information preservation, that are primarily

based in the convergence of information science and cognitive science, enabled by nanotechnology. Other applications may also draw heavily upon biotechnology. This moment of opportunity is revolutionary, because it gives us entirely new goals, as well as new means to achieve traditional purposes. Intimate personal science and personal technology offer augmented memory, cognition, reality, and society. Ideas that have previously been unthinkable will vastly enhance the human mind through cognitive technologies.

## References

- Bainbridge, W. S. 1914. *The Cancer Problem*. New York: Macmillan.
- Bainbridge, W. S. 1919. *Report on Medical and Surgical Developments of the War*, special issue of *United States Naval Medical Bulletin*, January.
- Bainbridge, W. S. 1922. *Report on Congrès International de Médecine et de Pharmacie Militaires*, special issue of *United States Naval Medical Bulletin*, 17(6), December.
- Bainbridge, W. S. 1925. *Report on Second International Congress of Military Medicine and Pharmacy*, book reprinted from *The Military Surgeon*, December 1924, January 1925, and February 1925.
- Bainbridge, W. S. 1994. Semantic differential. Pp. 3800–3801 in R. E. Asher and J. M. Y. Simpson (eds.), *Encyclopedia of Language and Linguistics*. Oxford: Pergamon.
- Bainbridge, W. S. 2000 Religious ethnography on the World Wide Web. In J. K. Hadden and D. Cowan (eds.), *Religion and the Internet*. Greenwich, Conn.: JAI Press.
- Bainbridge, W. S. 2002a A prophet's reward: Dynamics of religious exchange. Pp. 63–89 in Ted G. Jelen (ed.), *Sacred Markets, Sacred Canopies*. Lanham, Maryland: Rowman and Littlefield.
- Bainbridge, W. S. 2002b. Public attitudes toward nanotechnology. *Journal of Nanoparticle Research* 4: 561–570.
- Bainbridge, W. S. 2002c. Validity of Web-based surveys. Pp. 51–66 in O. V. Burton (ed.), *Computing in the Social Sciences and Humanities*. Urbana, Illinois: University of Illinois Press.
- Bainbridge, W. S. 2003a. Massive questionnaires for personality capture. *Social Science Computer Review* 21: 267–280.
- Bainbridge, W. S. 2003b. Sacred algorithms: Exchange theory of religious claims. Pp. 21–37 in D. Bromley and L. Greil (eds.), *Defining Religion*. Amsterdam: JAI Elsevier.
- Bainbridge, W. S. (ed.). 2004a. *Berkshire Encyclopedia of Human-Computer Interaction*. Great Barrington, Mass.: Berkshire.
- Bainbridge, W. S. 2004b. The future of the Internet: Cultural and individual Conceptions. Pp. 307–324 in P. N. Howard and S. Jones (eds.), *Society Online: The Internet in Context*. Thousand Oaks, Calif.: Sage.
- Bainbridge, W. S. 2004c. Social and ethical implications of nanotechnology. Pp. 1135–1151 in B. Bhushan (ed.), *Handbook of Nanotechnology*. Berlin, Germany: Springer.

- Bell, G., and J. Gray. 2001. Digital immortality. *Communications of the Association for Computing Machinery*, 44: 29–31.
- Bloom, P. 2004. *Descartes' Baby: How the Science of Child Development Explains what Makes Us Human*. New York: Basic Books
- Budge, E. A. W. 1964. *The Mummy: Chapters on Egyptian Funereal Archaeology*. New York: Biblo and Tannen.
- Castells, M. 2000. *The Rise of the Network Society*. Oxford: Blackwell.
- Crevier, D. 1993. *AI: The Tumultuous History of the Search for Artificial Intelligence*. Basic Books, New York.
- David, R., and E. Tapp. 1984. *Evidence Embalmed: Modern Medicine and the Mummies of Ancient Egypt*. Manchester, England: Manchester University Press.
- Dennett, D. C. 1995. *Darwin's Dangerous Idea*. New York: Simon and Schuster.
- Garmey, S. 1984. *Gramercy Park*. New York: Blasam/Rutledge.
- Kisseloff, J. 1989. *You Must Remember This: An Oral History of Manhattan from the 1890s to World War II*. New York: Schocken.
- Leca, A.-P. 1981. *The Egyptian Way of Death*. New York: Doubleday.
- Lesk, M. 1997. *Practical Digital Libraries*. San Francisco: Morgan Kaufman.
- Lively, K. J., and D. R. Heise. 2004. Sociological realms of emotional experience. *American Journal of Sociology* 109: 1109–1136.
- Merton, R. K. 1973. *Science, Technology and Society in Seventeenth-Century England*. New York: Harper and Row.
- Murray, H. A. 1981. *Endeavors in Psychology: Selections from the Personology of Henry A. Murray*. New York: Harper and Row.
- Osgood, C. E., G. J. Suci, and P. H. Tannenbaum. 1957. *The Measurement of Meaning*. Urbana: University of Illinois Press.
- Osgood, C. E., W. H. May, and M. S. Myron. 1975. *Cross-Cultural Universals of Affective Meaning*. Urbana: University of Illinois Press.
- Peale, N. V., and S. Blanton 1950. *The Art of Real Happiness*. Englewood Cliffs, N.J.: Prentice-Hall, 1950.
- Pelham, B. W. 1993. The Idiographic nature of human personality: Examples of the idiographic self-concept. *Journal of Personality and Social Psychology* 64: 665–677.
- Pinker, S. 1997. *How the Mind Works*. New York: Norton.
- Quinlan, Philip T. (ed.). 2003. *Connectionist Models of Development: Developmental Processes in Real and Artificial Neural Networks*. New York: Psychology Press.
- Ray, I. 1863. *Mental Hygiene*. Boston: Ticknor and Fields.
- Ray, I. 1871. *Treatise on the Medical Jurisprudence of Insanity*. Boston: Little, Brown and Company.
- Roco, M. C., and W. S. Bainbridge (eds.). 2001. *Societal Implications of Nanoscience and Nanotechnology*. Dordrecht, Netherlands: Kluwer.
- Roco, M. C., and W. S. Bainbridge (eds.). 2003. *Converging Technologies for Improving Human Performance*. Dordrecht, Netherlands: Kluwer.
- Roco, M. C., and C. D. Montemagno (eds.). 2004. *The Coevolution of Human Potential and Converging Technologies*. New York: New York Academy of Sciences (Annals of the New York Academy of Sciences, volume 1013).
- Schultz, T. R. 2003. *Computational Developmental Psychology*. Cambridge, Mass.: MIT Press.

- Seaver, J. W. 1892. *Anthropometry and Physical Examination*. New Haven, Conn.: Tuttle, Morehouse and Taylor.
- Shoda, Y., W. Mischel, and J. C. Wright. 1994. Intraindividual stability in the organization and patterning of behavior: Incorporating psychological situations into the idiographic analysis of personality. *Journal of Personality and Social Psychology* 67: 674–687.
- Smith, M. B., J. S. Bruner, and R. W. White. 1956. *Opinions and Personality*. New York: John Wiley.
- Stark, R., and W. S. Bainbridge. 1985. *The Future of Religion*. Berkeley: University of California Press.
- Stark, R., and W. S. Bainbridge. 1987. *A Theory of Religion*. New York: Lang.
- Stark, R. and R. Finke. 2000. *Acts of Faith*. Berkeley: University of California Press.
- Stein, D. J., and J. Ludik (eds.). 1998. *Neural Networks and Psychopathology*. Cambridge, England: Cambridge University Press.
- Taylor, J. H. 1966. *Unwrapping a Mummy: The Life, Death and Embalming of Horemkenesi*. Austin: University of Texas Press.
- Weber, M. 1958. *The Protestant Ethic and the Spirit of Capitalism*. New York: Scribner's.
- Westfall, R. S. 1958. *Science and Religion in Seventeenth-Century England*. New Haven, Conn.: Yale University Press.
- Wilson, E. O. 1998. *Consilience: The Unity of Knowledge*. New York: Knopf.
- Zajonc, R. B. 1998. Emotions. Pp. 591–632 in D. T. Gilbert, S. T. Fiske, and G. Lindzey (eds.), *The Handbook of Social Psychology*. Boston: McGraw-Hill.

## 15. NBIC CONVERGENCE AND TECHNOLOGY-BUSINESS COEVOLUTION: TOWARDS A SERVICES SCIENCE TO INCREASE PRODUCTIVE CAPACITY

*Jim Spohrer, Douglas McDavid, Paul P. Maglio, IBM Almaden Services Research, and James W. Cortada, IBM Institute for Business Value*

*Abstract:* In 1776, Adam Smith argued that specialization of labor increases productive capacity. Over the past 228 years, as markets expanded and new industries were established, there was indeed a dramatic increase in labor specialization. We do not believe this drive toward specialization is slowing down. Nevertheless, we argue that processes of scientific–technological convergence and technology–business coevolution naturally and periodically give rise to the need for specialists who are deep at the intersections of richly interconnected disciplines. Thus, paradoxically, one generation’s generalists may become the next generation’s specialists. In particular, we describe an emerging services science discipline and profession that lies at an area of rich interconnection among existing disciplines. We argue that a services science will help us improve our ability to rapidly develop and deploy well-designed, effective, and valuable capabilities in today’s information services economy. Services science aims to understand ways to rapidly increase productive capacity by accelerating the successful deployment of new technologies and improved capabilities, such as those brought about by NBIC technology convergence. Our speculative discussion of the emergence of services science begins to explore the opportunity of matching social-organizational progress rates with technological progress rates.

### **Introduction**

In “Wealth of Nations,” Adam Smith argued that specialization and division of labor increase a nation’s productive capacity (Smith, 1776). Indeed, as markets expanded and new industries were established, there was a dramatic increase in labor specialization (Kim, 1989). In this chapter, we argue that processes such as scientific–technological convergence (Roco and Bainbridge, 2002) and technology-business coevolution (Murmann, 2003) naturally and periodically give rise to the need for specialists who have deep knowledge and skills at the intersections of richly interconnected disciplines. Sometimes the emergence of these multidisciplinary specialists in sufficient numbers gives rise to new disciplines and professions. Thus, paradoxically, one generation’s generalists may become the next generation’s specialists.

The process of scientific–technological convergence is well underway when advances in one discipline lead to rapid advances in another discipline

(Roco and Bainbridge, 2002). The rapid advances occur when models in one area begin to be causally connected to models in another area. For example, the study of electricity and the study of magnetism converged to form the study of electromagnetism in the late 1800s. NBIC (nano-bio-info-cogno) convergence seeks to understand the causal connections among four areas: molecular construction machinery (nano: genetics, proteomics), the development of human bodies and brains (bio: embryology, physiology, neurophysiology), human behavior (cogno: cognitive development, psychology), and computational models of complex adaptive systems (info: computer science, agent simulations, game theory). Convergence is essentially complete when a single new model has been developed that describes, explains, and predicts phenomena across previously separate areas (Spohrer and Engelbart, 2004).

The process of coevolution is well underway when the growth of causal connections between two (or more) systems begins to lock the systems into a positive feedback loop that ratchets them up and draws them closer together. Thus, the two systems become codependent from a viability and growth standpoint. For example, modern business could not exist without information technology (IT), and conversely, the rapid pace of modern IT progress could not continue without investment from profitable businesses. We can postulate, therefore, that Moore's Law is as much a law of investment as it is a law of technology. As businesses develop and deploy new technical capabilities, causal connections between innovative business models and innovative technologies come into focus. Numerous studies on the economics and history of technology confirm this pattern (Foster, 1986; Schumpeter and Swedberg, 1991; Chesbrough, 2003; Cortada, 2004).

In this chapter, we illustrate that both convergence and coevolution processes result in new specialists that span previously separate disciplines. Indeed, we conclude that it is the interaction of these two processes that affects the activities of organizations, industries, and of course, specific roles and jobs. Our starting point is the observation that both convergence and coevolution are driven by human and business activities. Scientists seeking deeper understanding of nature are driving NBIC convergence. Business professionals, technologists, academics, and government policy makers acting to create better win-win social games for capturing value from old and new capabilities are the natural phenomena that social and managerial scientists are studying to understand coevolution. NBIC convergence is itself part of the coevolution of technology and business innovations. Scientists doing research in NBIC areas would not have the advanced tools they need were it not for the investments being made by businesses and governments, each seeking appropriate returns, be they capital or high value, high skills jobs.



We introduce the term social games because game theory, an interdisciplinary approach to the study of human behavior, is one important tool in the emerging discipline of services science. We also prefer the term social games not because people involved in these activities necessarily feel like they are playing a game, but because social games have many characteristics of games, such as choice, payoffs, and risks. To the participant, most social games we consider are in fact very serious games in which career success and elements of personal identity are often at stake; cumulatively, even the wealth of nations could be at stake.

We present evidence that a services science discipline and practice is beginning to emerge in part to increase the probability of success of complex services engagements. For our purposes, services complexity is related to the number of connected people acting in coordination to produce a desired outcome. Collectively, all complex services engagements define an especially interesting category of social game. The goal of services science is to develop a deeper understanding of the human and business dynamics of capability evolution, both the successes and necessary failures, and to apply that understanding to better develop, deploy, and capture value from well-designed capabilities. Well-designed capabilities allow new win-win social games to be successfully played – improving payoffs, minimizing risks, enhancing identities, and maximizing fairness for all stakeholders. People want to participate in win-win social games that make them healthier, wealthier, wiser, and freer (Sen, 2000). The best of these win-win social games are sometimes referred to as business-model innovations or public policy innovations. These social games are every bit as important as technological innovations in providing a capabilities infrastructure for the growth of today's information services economy (Porat, 1977).

In the next two sections, we provide perspectives on the human and business dynamics of capability evolution. Convergence and coevolution are two important processes at work in shaping the development of capabilities. We then introduce the emerging discipline and profession of services science. We present evidence that this discipline and profession is taking form as academics and practitioners collaborate in defining a new specialty, not unlike the formation of computer science in the early 1960s. We argue that this new academic discipline and its corresponding labor specialization could improve our ability to rapidly develop, deploy, and capture value from new capabilities in complex services engagements. Our speculative discussion of the emergence of services science begins to explore the opportunity of matching social-organizational progress rates with technological progress rates.

### **Human Dynamics of Capability Evolution**

What is the “nature of man” (Jensen and Meckling, 1994), and how do people choose to invest their time? George Miller (1983) describes modern humans as *informavores*, attempting to maximize useful information intake per unit time, in contrast to early humans, who were *omnivores*, attempting to maximize useful caloric intake per unit time. Our perspective on the nature of people is that people are creative and productive. People invest their time to capture value either from exploiting known capabilities or in creating new capabilities. James March (1999) refers to this as the exploitation (use old capability) versus exploration (use new capability) trade-off of systems that learn and evolve. Our definition of a capability is simply a practical plan for achieving a goal to create value. For humans, capabilities come in four basic types: technological (tools), social (relationships, organizations), cognitive (skills, attitudes, ideas), and environmental (nature, useful spaces, culture), which is derivative and cumulative of the others (Bardini, 2001; Spohrer and Engelbart, 2004).

Significantly, there are many causal connections among these four types of capabilities (tools, organizations, skills, cultures). For example, new tools start as ideas that must be built, used, and maintained, and these activities often require development of both specialized skills and organizations (starting as ideas) that draw on simpler capabilities and return enriched capabilities back to the environment or culture. The story of the telephone is as much a story of building organizational capacity and new human skills and attitudes as it is a story of technical invention (Norman, 1994). New capabilities create the opportunity for new experiences, and people choose whether to participate in the new (explore, new connections) or participate in the old (exploit, old connections). Robert Wright (2002) observed that throughout history, people tend to choose experiences that lead to win–win outcomes with others. Hence, in situations in which new capabilities create better win–win social games, people tend to adopt those capabilities and to participate in those new experiences. Recent research on communities of practice in modern work environments confirm that this pattern of behavior has continued right into the present (Prusak and Davenport, 1998; Cohen and Prusak, 2001; Davenport and Prusak, 2003; Lesser and Prusak 2004).

One perspective on the human dynamics of capability evolution can be gained from observations of the types of work activity (microlevel) that people have done in different eras, or more recently, the many types of specialized jobs they have (macrolevel). Historically, the organization of work progressed from the earliest nomadic hunting and gathering societies to settled agricultural societies to classic civilization to feudal systems to merchant capitalism to the factory system to mass production and, finally, to the postindustrial society of today. Over time, the level of organization of

both work and society increased in complexity (number of connected people acting in coordination to produce an outcome), which was driven by or enabled by increasing capacity for information processing and transmission, among other technologies. Technologies that support higher densities of people living close to one another, for example, in cities (Landes, 1998; Johnson, 2001; Castells and Susser, 2002), were especially important over the last 3000 years, or roughly 150 generations.

Malone (2004) describes the three stages of human societal organization as (1) independent (nomadic bands), (2) centralized (kingdoms), and (3) decentralized (democracy). The three stages in Malone’s analysis succeed one another as communications capabilities evolved from person-to-person and face-to-face to writing and printing, and then to global electronic communications. The latest iteration of this pattern at the organizational level enabled the evolution of modern managerial firms (Chandler, 1977). In each of the three stages, the nature of work, the number of relationships, and the number of specializations is changed. Complexity scientists and authors have observed similar emergent network-forming characteristics of many complex adaptive systems as diverse processes generate increasing numbers of connections among elements (Kaufman, 1996; Axelrod and Cohen, 2000; Johnson, 2001; Rheingold, 2002; Watts, 2003).

Why is IT so important? Improved information communication and processing technologies support better coordination of human activity. IT advances create the potential for improved collaboration and project management over greater spans of time and space and numbers of people. From the perspective of technology–business coevolution, we observe four basic types of coordination between people and technology. Each of the four can result in significant change in work practices (see Figure 1).

**Figure 1. The Choice to Change Work Practices**

	<b>Tool System</b>	<b>Human System</b>
<b>Do all of it</b>	Automate (close)	Delegate (distribute)
<b>Do some of it</b>	Augment (integrate)	Collaborate (open)
	Harness Nature (Techno-scientific models with stochastic parts)	Organize People (Socio-economic models with intentional agents)

The four types of work coordination methods shown in Figure 1 are automation, augmentation, delegation, and collaboration. Automation is when technology is used as a substitute for specific human activity. Augmentation is when technology and people work together to achieve more

than is possible by either alone (Bardini, 2001). Delegation is when one person or group relies on another to accomplish some work. Collaboration is when people work together to achieve mutually beneficial goals (Greif and Millen, 2003; Maglio *et al.*, 2003). Achieving goals requires work, which can be accomplished by coordinating either technology or people or both.

One way to look at these four types of work coordination methods for achieving goals is as four different ways of transferring the responsibility for generating value within a system or between systems. Responsibility can be transferred or shared by harnessing nature to do work (automate, augment) or by organizing people to do work (delegate, collaborate). Responsibility can be transferred from one person or group to another person or group by delegation. Responsibility can be transferred from a person or group to a tool system, automating what was formerly done by people. Many mundane tasks were automated in the later 1900s in such industries as appliances, automotive, petroleum, and agriculture (Cortada, 2004). Partial responsibility can be transferred by bringing in help, in that a tool might augment a person's capacity or that people might collaborate to share effort required by a particular job.

The choice to transfer or share responsibility and hence transform work practices often involves answering four questions: Should we? Can we? May we? Will we? "Should we?" typically starts with the idea that an improvement is possible but then moves to discussions concerning potential negative side-effects and risks, which could mitigate the perceived value of any payoffs. Often deploying new capabilities creates new problems to be solved. "Can we?" deals with the invention of capabilities to achieve the goal and is often a question of technical abilities and coordination abilities. "May we?" is the question that deals with gaining permission from the stakeholders and all those impacted by the potential change as a social game. "Will we?" deals with relative priorities, as all change requires resources and those resources may be occupied in other, higher-priority pursuits.

When deployed, each type of work coordination method results in the creation of new, potentially complex, relationships among people and technology as responsibilities shift. For example, when a tool system automates or augments some human work, a new relationship is formed between tool developers and tool users. The outcome then depends on both the quality of the tool maker as well as the quality of the tool users (e.g., violin maker and violin performer). Similarly, when individuals or groups delegate or collaborate on specific work, there is often a need for a specialized new category of work to manage or facilitate the relationship among those delegating and collaborating. McCorduck (1985) has done pioneering studies in the paper industry examining this category of specialized, emergent type of work. Also, if the relationship breaks down, specialized legal and judicial categories of work may be invoked. This

pattern – first responsibility shifts, then new relationships form, and finally specialized categories of work emerge to support and maintain the relationships – occurs over and over again throughout history. The emergence of new relationships and specialized categories of work is rather predictable, including the need to punish defectors, cheaters, and free loaders. Given that relationships are important, relationship-oriented computing tools that enable tracking reputations and relevancy ranking mutually beneficial goals ought to be important as well. In fact, there is growing evidence that this is increasingly the case (Davenport, 1997; Cortada, 2004; Lesser and Prusak, 2004).

We now present four examples of emerging capabilities with disruptive potential for work practice change. The examples were chosen to illustrate the four types of work coordination methods as well as to highlight some implications of advancing NBIC technology capabilities.

#### *Automate*

Stereolithography tools allow three-dimensional objects to be created layer by layer through a “printing” or scanning and solidification process. This type of automation eliminates many intermediate steps (some human and some tooling) that are part of normal manufacturing and production processes. Automation creates the opportunity for specialization of tool users and tool makers. Stereolithography, or “3D printing” capability, is advancing rapidly beyond basic production of plastic models of prototype products. As new materials such as ceramics are integrated into the process, functional prototypes that can work in high-temperature environments can be produced. New materials also allow for the creation of working replacement teeth and bones for medical procedures. Researchers have already begun using living materials to explore the notion of “printing” living tissue. The ultimate goal of this line of investigation is to someday be able to produce whole organs. In other work, researchers have begun investigations aimed at printing completely functional electronic products including both electronics and packaging.

The use of ceramic materials, living materials, and electronic materials provides an indication that this is a potentially important area for applying NBIC convergence advances. When this happens, the work practice implications could be quite profound, having an impact on nearly every aspect of work related to production or consumption of material goods. Developments that move advanced capabilities into the hands of everyday people can be transformative for societies, and this has happened multiple times through history. For example, home-brew computer clubs helped launch the personal computing revolution when college students gained access to integrated circuit components. These developments also

foreshadowed the cycles that several industries have experienced moving from being vertically integrated to being horizontally integrated, and back and forth (Fine, 1999). Also, lest these NBIC applications seem too futuristic, we note just one of many nearer-term implications for rapid manufacturing; namely, “on-demand book” publication. For example, mobile printing of books could someday mean that Amazon.com book orders would be fulfilled in the back of the Federal Express delivery truck that happens to be driving by the delivery address. In fact, “bookmobiles” for printing books on demand already exist (Koman, 2002). In sum, NBIC advances will likely lead to advances in stereolithography. Stereolithography advances have the potential to transform society with the ability to replicate complex artifacts on demand.

### *Augment*

Augmenting performance with tools is one of the chief ways that work practices evolve, as responsibility becomes shared between tool users and tool makers. The professions of tool users and tool makers may both become more specialized. Telerobotics is one emerging area of NBIC convergence with the potential to disrupt work practices. Stronger and lighter materials with more of the desired properties of human body parts are making their way into advanced robotic applications. Also, better understanding of human cognitive processes for coordinating brain and body are helping to inform the development of advanced robotic and telerobotic capabilities. Currently, transatlantic surgery is more of a feasibility demonstration than anything else, but nevertheless this advancing capability foreshadows the day when many types of physical work might be done remotely. For instance, teleoperated vehicles provide the opportunity for easily changing drivers at the end of a shift. Just as call centers route callers to different specialists, teleoperated vehicles and devices could “beam in” the best operators to address current needs. (e.g., driving in the snow). The ability to bring in the “best” expert on demand is a significant advance for coordinating effective collaborations, and this is increasingly being done for critical operation problems in a number of industries (Cortada, 2004). Just as remote call centers allow low-cost labor markets to be tapped, similar “control by wire” systems may develop for other segments of the economy. NBIC may have an impact both through stronger and lighter materials as well as through improved sensor-effector technologies. Furthermore, current research in human adaptiveness to prosthetic limb replacement may also shed light on human adaptiveness to remote work via telerobotics (Clark, 2003).

*Delegate*

Delegating work to other people and organizations has many implications for work practice evolution. Capability advances in telerobotics and stereolithography may dramatically transform what can be delegated. Typically, specialization occurs as professions that support delegation relationships refine their offerings associated with contract creation, management, enforcement, regulation, and arbitration, as well as transaction optimization and a host of other support activities. We consider just two implications for work practice evolution here, both in the context of outsourcing call centers to lower cost labor markets. The first relates to the relationship between work infrastructure and education infrastructure. As advanced communication systems have come online to support call centers, simultaneously enhanced distance-learning infrastructure has become more broadly available. Amartya Sen (2000) describes the importance of education as one of the building blocks of regional development. Many developing regions of the world show great interest in NBIC advancements, and combining educational advances with favorable regulatory climates could give advantages to certain regions willing to aggressively pursue technology advances that have complex societal implications. The second implication for work practice change relates to the fundamental problem of time zone challenges in global work. NBIC advances that allow people to be healthier while also being more flexible about dealing with wake and sleep issues could have significant implications for work practice change – perhaps as significant as the three-shift work system that early factories put in place to boost utilization of industrial machinery.

*Collaborate*

Technology-enabled collaboration advances have the potential of being very disruptive for certain types of work practices. For instance, the success of many open source software projects illustrates that these new ways of accomplishing work can be very effective. The ability to accelerate NBIC advances, like those in many other emerging technology areas, is likely to benefit from systems that support multidisciplinary distributed intelligence. Alec MacAndrew (2004) provides a nice illustration of multidisciplinary distributed intelligence, as models of genes, brains, and speech became more connected as a result of work from different researchers sharing and connecting results. As great as the potential of these so-called “collaboratories” is for accomplishing work with volunteer armies, appropriate business models to sustain them beyond an initial novelty phase are still lacking in many cases (Benkler, 2002).

In summary, the human dynamics of capability evolution can be measured over time at the microlevel (types of work activities and their migration) and the macrolevel (types of jobs and their migration). At the microlevel, the way people spend their time in work-related activities can be measured, along with what percentage of the day they spend engaged in work. At the macrolevel, the types of jobs that people hold in a society can be measured. Because of the growing realization that converging NBIC technology capabilities are about to play a profound role in reshaping society, developing a better understanding of the dynamics of technology–business–work coevolution seems increasingly important. Furthermore, we believe a services science could help to achieve these insights more rapidly. We believe the growing abundance of service engagement data, both successes and failures, needs to be better captured and analyzed to achieve these insights more rapidly. Thus, to continue to lay the groundwork for our argument of the benefits of a services science, we now turn to issues of the business dynamics of capability evolution.

### **Business Dynamics of Capability Evolution**

The modern managerial firm, which we associate today with the notion of a business, is a relatively recent innovation (Chandler, 1977; Chandler *et al.*, 1997). The fields of economics, finance, management, organizational sociology, and organizational behavior have matured as the “nature of the firm” has been described (Coase, 1937; Aldrich, 1999; March, 1999). Our perspective on the nature of businesses is that businesses are creative and productive, and that businesses invest their resources to capture value either from exploiting known capabilities or in creating new capabilities. The number of businesses has dramatically increased over the past 200 years. The ability of firms to coordinate work has been enhanced by information communication and processing technologies, among others, connecting the many businesses. The connections appeared first in the form of distribution channels, then supply chains emerged, and much more recently, business process outsourcing ecosystems have emerged.

Businesses are complex adaptive systems in which people work to create win–win social games for their many stakeholders, including customers, shareholders, employees, and partners. To try to understand the complexity of these systems, we look at business in terms of architecture, by which we mean an abstract conception of its construction or structure. There are four different architectural perspectives: microarchitecture, macroarchitecture, ecoarchitecture, and semantic-architecture. We view the microarchitecture of business as similar across all businesses. Macroarchitecture concerns the structure and function of individual businesses. The ecoarchitecture perspective considers the ways businesses interact with one another in the



marketplace. A semantic-architecture is concerned with concepts and language used by people to talk about all aspects of business. We discuss each of these perspectives in turn. Each builds on prior work by researchers in a variety of fields (Davenport, 1997; Carroll and Hannan, 2000).

#### *Microarchitecture*

The microarchitecture of business is the fundamental stuff from which businesses are made. At a microarchitecture level, there is a high degree of commonality and a fundamental simplicity to businesses. The microarchitecture of all business organizations is based on a structure of conversations, commitments, contracts, and transactions against those contracts. Much data managed by IT systems in modern businesses are merely means of capturing exactly these conversations, commitments, contracts, and transactions, both among internal groups and between a business and its external trading partners. Though this may sound too simple a set of building blocks to account for the complexity and variation of modern business enterprises, consider that throughout the natural world a small number of building block often leads to enormous variation (e.g., DNA is composed of sequences of just four nucleotides — adenine, guanine, cytosine and thymine — yet gives rise to all the complexity of life). Microarchitecture analysis seeks a small set of building blocks that can be put together in rich combinations to account for the activities of business.

#### *Macroarchitecture*

The macro-level view of business architecture allows us to see differences and commonalities of individual businesses and of types of businesses. Macroarchitecture can be specified using many different formalisms and provides a representation of the structure and function of a business (Porter, 1996; Slywotzky and Morrison, 1997). Structure and function modules can be instantiated and composed in many ways to represent any particular business. For example, in a franchise business, each store could be a module, instantiated with different locations, employees, and other unique characteristics. A traditional departmental organization breakdown could also be used, with each module being a different department, such as accounting, human resources, engineering, manufacturing, marketing, sales, and so on. Another example is the adaptive enterprise framework (Haeckel, 1999), which provides modules for capabilities, dispatch, governance, and so forth.

### *Ecoarchitecture*

This view represents multiple enterprises as they interact with each other in a business or marketplace environment. Economists describe the interactions within and among the businesses in industries and sectors that make up the overall economy. Consultants and business management scholars describe the interactions in terms of value chains or supply chains in ecosystems (Iansiti and Levien, 2003). Business process outsourcing relationships and other forms of partnerships are represented by the ecoarchitecture. New business-to-business relationships result from the accelerating deconstruction and reconstruction of businesses and industries brought on by strategic outsourcing (SO), business process reengineering (BPR), and business transformation (BT) activities. The challenge of representing the ecoarchitecture of a business is complicated by the rapid and fluid movement of capabilities from inside a firm to outside the firm, and the increasingly complex nature of the relationships between firms, as well as relationships addressing regulatory and compliance issues.

### *Semantic-Architecture*

The fourth architecture is orthogonal to the micro-, macro-, and ecoarchitectural views. Semantic-architecture provides a business language model (McDavid, 1997, 1999), complete with nouns and verbs for talking about all the other views, and an extensible framework for adding new terms and concepts. The upper ontology of the semantic architecture is shown in Figure 2.

Based on an architectural view of business (micro-, macro-, eco-, and semantic-), we can begin to zero in on the work practices of services professionals who must co-create value with clients as new capabilities are developed and deployed in organizations. We see the need for a special class of tool system that augments the work of services professionals, who provide consulting and IT-based services for business clientele (see Figure 3). These are complex services engagements involving the coordinated activities of large numbers of people adapting to technology innovations or business model innovations that impact work practices in a client organization. Services firms that regularly deliver technology and business model innovations to clients must be complex, adaptive, and heavily based on evolving knowledge of technology and business practices. As we have described, both the technology and the business practices present moving targets and are locked in a coevolutionary spiral. In this dynamic environment, one kind of augmentation required for the services professionals is a kind of pattern-matching support, which matches

Figure 2. Semantic Architecture

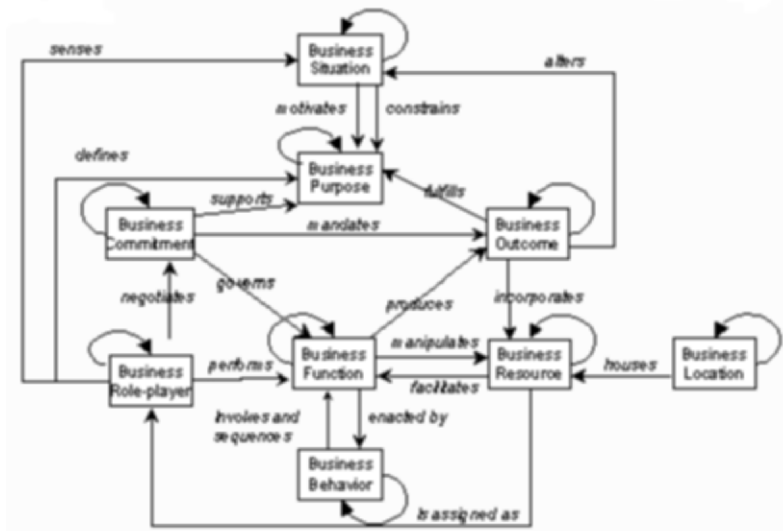
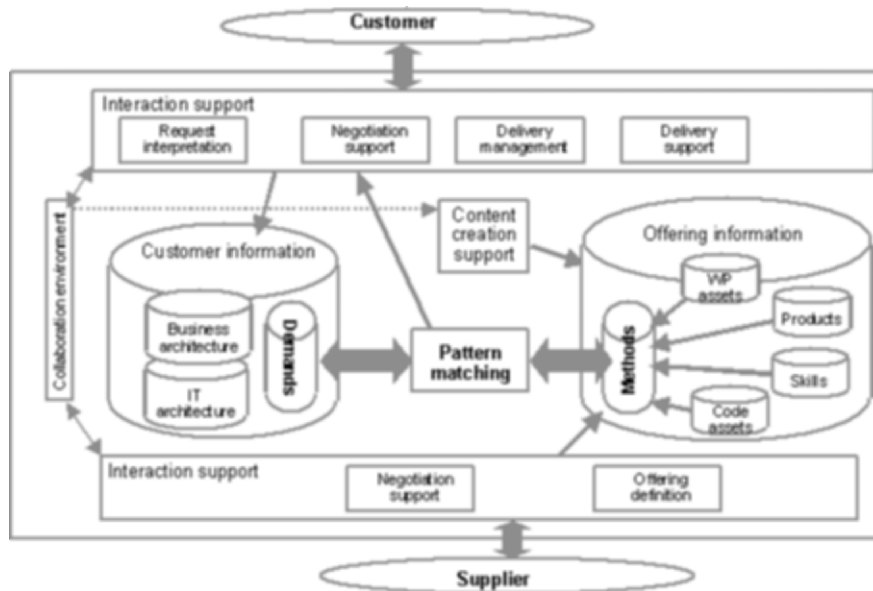

Figure 3. Proposed Pattern-Matching Tool for Services Professionals to Use to Find and Evolve Capabilities



organizational opportunities to capabilities. The tool might work with, on the one hand, information representations of the client situation and the demands that the client presents to the service provider as well as, on the other hand, the characteristics and capabilities of technologies, expertise, and knowledge content provided by suppliers and partners. This tooling augmentation might become the substrate for an ecosystem of technologists and businesspeople, who alternatively play roles of clients, practitioners, and suppliers, and who interact through supported contractual negotiations and complex pattern matching of organizational needs and relevant capabilities. In sum, as the coevolution of technology and business innovations continues, the need for powerful pattern-matching tools that can assist services professionals in connecting opportunities and capabilities is one area for exploration. Equally important to the evolution of capabilities will be infrastructure for capturing and analyzing services engagement data and for measuring the degree to which the outcomes were successful.

Now that we have provided a very brief overview of the human and business dynamics of capability evolution and work practice change, highlighting convergence and coevolution processes that expose causal connections between separate elements of systems, we are ready to more fully introduce the emerging discipline and profession of services science.

### **Towards a Services Science**

What processes drive the creation of new disciplines and professions? For example, how did the discipline of computer science and the profession of computer science come into being? One cannot overlook the role that the U.S. government played, recognizing the competitive advantage that leadership in IT and computers could bestow on the nation. However, professions arise to address real business needs, and sciences arise only where a wealth of important new data can be obtained and organized to advance deeper understanding of a domain with useful applications. New disciplines arise only as new generations of academics are attracted to and seek to develop their personal and professional identities along a new frontier. The desire to be identified as a pioneer is important, but the practical matter of funding and tenure and other types of support are necessary. A necessary precondition for the creation of a services science discipline and profession may rest in the hands of government policy makers. The policy makers must be convinced that breakthroughs in services science will be a key source of competitive advantages in the 21st century's services-dominated global economy. The name and the real content of a "services science discipline" must create a win-win social game for many stakeholders.

Services science is a proposed new discipline that pulls together key knowledge and methods from multiple disciplines into a new focus area. Each new services engagement is an experiment for this new science, generating data that must be captured, organized, and analyzed to advance the discipline. The main academic payoff of a deeper understanding of services science would be to leverage this rich experimental data source to achieve a potential breakthrough in knowledge about the nature of human and social dynamics. The main practical payoff is to improve the success rate of services engagements in which new technology innovations, business model innovations, and other complex capabilities must be deployed in organizations, driving significant work practice changes. The more people that must be coordinated by diverse means, the greater the complexity of the services engagement is. Real-world, complex services engagements should be the phenomenon under study to drive the development of a services science infrastructure and services science curriculum.

A small, uniform population of workers or organizations whose work practices must be transformed in a uniform way by the deployment of a capability is typically much easier to achieve than a transformation of a large, heterogeneous population of workers or organizations. For example, James Hoopes (Hoopes, 2003) compares the adoption of the cotton gin in an early agricultural economy (rapid adoption – simple individual operator, basic skills, immediate results adoption pattern) to the adoption of statistical quality control in an advanced manufacturing economy (slower adoption – complex of organizational stakeholders, advanced skills, delayed results adoption pattern). One important area of study that a services science would draw on would be the study of the diffusion of innovation (Rogers, 2003).

On an even broader and more practical basis, such a new discipline, and its accompanying development of knowledge, skills, and tools, would further enhance the practice of management. In many ways, management remains a field of human activity still in embryonic form, and thus ripe for the additional discipline that scientific and social sciences approaches can offer (Drucker, 1972; Gerlach, 1992; Guillen, 1994). Management teams in advanced economies, for example, have demonstrated a particularly acute appetite for innovations as they strive to compete. The development and use of a services science could be especially valuable to management teams. The urgency, from their perspective, is augmented by the fact that the amount of work now done in any enterprise that can be called services is actually higher than most governments measure. A quick example illustrates the landscape. In a computer fabrication plant, or in a semiconductor factory, or even in an automobile assembly plant, the percentage of individuals who actually make things (e.g., “bend metal”) often is only 10 to 20 percent; the rest of the employees provide services, ranging from human resources to purchasing, to dealing with suppliers, and so forth (Cortada, 2004). Thus, a services science

would address manufacturers' issues as much as those of any other business community.

To further describe our notion of services science, we now introduce key terminology (services economy, capabilities, coevolution, relationships, activities, models) that we feel is fundamentally important in understanding the nature of services science and practice.

### *Services Economy*

We live in a services economy. Well-known manufacturing firms have increasingly large services components to their business. For example, IBM, which is well known as a manufacturer of computing components, systems, and software, also includes the largest IT services organization in the world, including more than half of IBM's employees. Furthermore, IBM Research has recently announced On Demand Innovation Services, which essentially creates a consulting services component to leverage deep technical capabilities in that organization, and large portions of the company's services business is already focused on the integration and deployment of technology and services in various combined forms. Advanced economies around the world are shifting to services as the preferred means of deploying capabilities so that additional value can be added to increasingly complex products, and so that clients, customers, and employees can more easily become co-creators of new offerings.

As Figure 4 illustrates, in a services economy, the majority of workers concentrate in services sectors. This is in contrast to an agrarian economy (majority farm workers) or a manufacturing economy (majority factory

**Figure 4. U.S. Employment Percentages by Sector,  
Adapted from Porat (1977)**

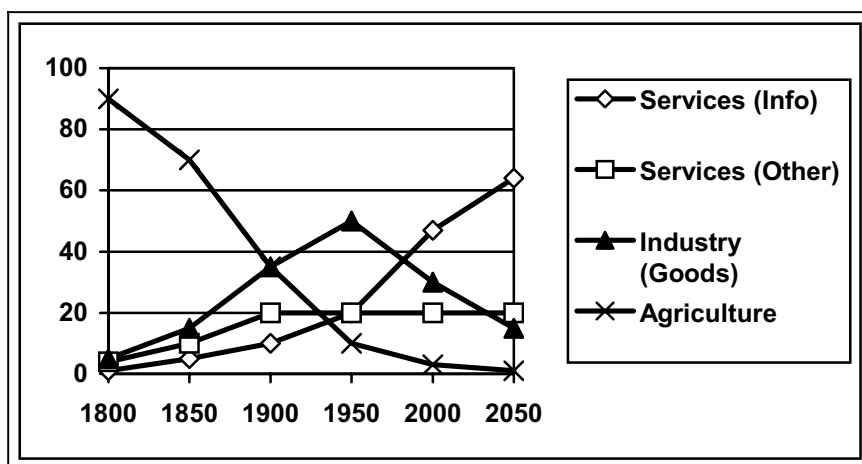

workers). Whereas agrarian and manufacturing economies are based on tangible output and often require large-scale distribution networks, a services economy moves into the realm of intangible outputs and may require sophisticated information communication networks (Dawson, 2003). Furthermore, today manufacturing and services are tightly blended together, such that traditional descriptors of services and manufacturing sectors do not sufficiently reflect this reality. Thus, even in an economy or industry that is characterized as manufacturing, services represent an increasing portion of the work.

Our services economy is a capability-rich environment that gives individuals and organizations an enormous number of choices. A key choice is deciding whether to do something for oneself or to allow others to do it for you, providing it as a service. For example, individuals must decide to cook dinner or go to a restaurant, and businesses must decide whether to operate an IT infrastructure in-house or outsource the IT infrastructure to a service provider. Services engagements are people and information intensive, so understanding labor availability and distribution is a critical planning component. Macroscale data (such as that in shown in Figure 4) as well as tools to automatically extract and aggregate these data from public sources help provide insights into the evolution of a services economy and provide headlights on what might be coming next. This is especially urgent at the industry level, where industry boundaries change and firms have to operate more globally.

### *Capabilities*

The four main types of capabilities available in a services economy are technological, social, cognitive, or environmental in nature. Capabilities are ways of getting work done. Capabilities are the instruments used in plans to achieve goals. Throughout human history, people have invested their time in creating tools (technology), organizations (social), skills (human), and spaces (environmental) to operate in, such that they can be creative and productive, perform work, and achieve goals. Just as tracking macroscale data on labor percentages is important, tracking mesoscale data on capability maturities is important to a services science. There is a strong element of coevolution between organizational requirements and technology maturity. Convergence occurs when technology is deployable on the basis of its own maturity and the ability of the organization to absorb it. Figure 5 illustrates the need to track the maturity of technology innovations, business model innovations, and other types of capabilities in understanding when the capabilities may be able to effectively address an organizational need. However, the requirements to track the other sets of capabilities also exist, complicated by the fact that we need methods for tracking their interactions.

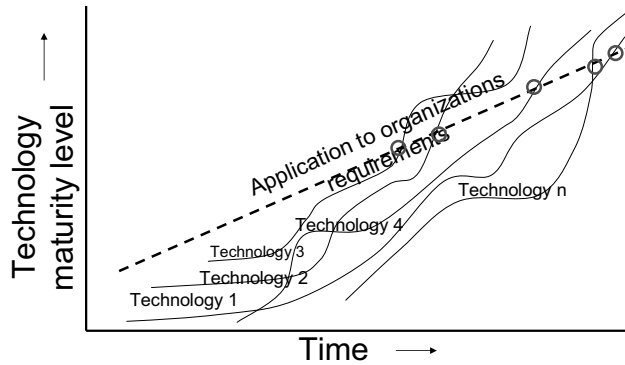
**Figure 5. Maturity of Technologies and Organizational Requirements**

### *Coevolution*

To understand the notion of coevolving capabilities, we need to introduce the notion of complex adaptive systems. A fundamental property of complex adaptive systems (Alexrod and Cohen, 2000; Murmann, 2003) is that they include types of variations (categories of things, species). For example, a technological system includes deployed telephones, mainframes, PCs, routers, and so forth. The number of individuals in any category may increase or decrease over time, and the categories may change and evolve over time. Occasionally, for reasons that remain poorly understood, two or more complex adaptive systems can enter into a positive feedback loop. The feedback loop creates mutual causal connections, such that the relative abundance of variations (categories) in one system can become causally connected to variations in another system. This phenomenon may lead to extreme codependency, such that the survival of one system depends almost entirely on the survival of the other.

In our services economy, technology innovations and business innovations have coevolved to the point that eliminating technology would destroy business as we know it, and destroying business would eliminate the investment required to drive rapid technological advances. We previously cited the example of the business investment required to drive Moore's Law. For another example, call centers depend on telephone technology. Successful call center services are increasingly turning to outsourcing to low-labor-cost geographies to remain competitive. The business model depends on the technology working. Enhancement to the technology to mitigate latency and other problems requires business investment to achieve quality of service guarantees.

In a global services economy, technology capabilities are coevolving with business model capabilities. In fact, some students of modern economic and business activity are beginning to argue that technological influences on



the nature of work have so altered the activities and structure of firms and industries that using traditional descriptors that invoke images of industrial age or mass manufacturing are misleading because a new style of operating had emerged by the late 20th century, one that is little understood, let alone even properly labeled and described (Goldstein, 1988; Cortada, 2004). Models are of extraordinary use in understanding the role of work, culture, technology, applications, firms, industries, and economies, and therefore their use in the development of a services science makes sense.

We recently organized two events, held at the IBM Almaden Research center, exploring the coevolution of capabilities related to technology, business, and work practices in a services economy. One focused on the coevolution of technology–business innovations, and the other considered the changing nature of work in the era of the global extensible enterprise. These events demonstrated interest in the use of modeling methods to cut across many disciplines. For example, these events provided evidence that anthropologists, cognitive scientists, economists, ethnographers, historians, system science, mathematicians, organizational behavior, sociologists, technologists (computer science, material science), and services professionals were eager to collaborate and learn from each other.

### *Relationships*

All capabilities come encapsulated or “wrapped” in people and organizations. Unless a capability will be independently redeveloped, access to it is gated by the need to establish a relationship with the appropriate people or organizations. For example, even the most automated technology systems require people to maintain them, improve their designs, and make decisions about when and where to deploy them or retire them. People and organizations own the patents on technology. Environmental capabilities – property or assets – have owners. Social capabilities too are composed of people. Human capabilities are embodied in individuals (brains and bodies). Human capabilities include their skills (including history of experiences), assets (including relationships), attitudes, and identity. People and organizations provide access to existing capabilities and create opportunities to co-construct new capabilities. People and organizations are the stewards of capabilities, and access to capabilities is either through redevelopment or relationships with these stewards. Often human and social dynamics are shaped by individual preferences for long-term relations or short-term relations. In any event, the nature of relationships and identities are key areas of inquiry to better understand the reasons for the success or failure of particular services engagements, especially engagements that require the co-construction of new capabilities.

Figure 6 shows an annotated screen shot of a tool that is in use at IBM to facilitate what we term relationship-oriented computing. With this tool, people can be looked up – where they are in the organization, who reports to them, who they report to, statistical properties of their organization, information about documents they have authored, and their relationships to other people and projects. Social networks form around the co-production of artifacts such as patents and papers, as well as project planning in group meetings. The role of coordination tools such as reputation systems, social network systems, and relevancy ranking systems needs further evaluation. The use of technology to enhance perceptions of trust and fairness, as well as the ability of individuals to form high-value co-production relationships, is a key area of exploration in services science.

**Figure 6. Prototype of Relationship-Oriented Portal for IBM**

Copyright 2004, IBM (reprinted by permission)

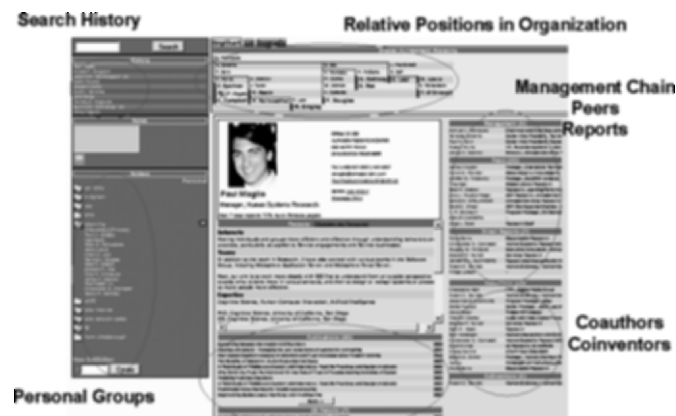

### *Activities*

People are the stewards of all capabilities. People invest their time in activities. The activity profile of an individual shows the amount of time spent engaged in different activities (e.g., meetings, phone calls, emails, etc.). Activity profiles are functions of many variables, associated capabilities, relationships, and models of self. Models of self include knowledge of skills, assets (including relationships), goals and attitudes (especially towards what can change rapidly and what should not change rapidly), and identity (including multiple identities based on roles in different social groups or organizations). In a services economy, work practices coevolve with technology and business model changes. When people's work practices must change, they can adapt to or resist those changes. Well-designed work practice transitions help people appreciate the benefits they will derive from

those changes. Every change can be viewed as an invitation for a person to play a new social game, requiring that they modify their activities (and possibly even their role-based identity). People embrace games with higher payoff, higher fairness, lower risk, and enhanced identity. People shy away from games with the opposite characteristics. A key part of a services science infrastructure is microscale data about activity profiles of workers, as well as the changes to models of self. Exploring the privacy and confidentiality issues associated with making use of this very important type of data is a critical goal of those seeking to promote a services science discipline. In the formation of the field of computer science, computer vendors could provide a computer to a university, and the university could instrument and study the system to create hardware and software improvements. A key challenge in the formation of the field of services science, new methods and policies to access critical data must be invented. Unlike other scientific disciplines that depend on instruments like microscopes or telescopes to open up access to new worlds of data, services science requires the permission of the observed to be obtained. This is the major challenge facing the new discipline. The good news is that inside the enterprise, this type of data is increasingly available.

### *Models*

The smooth operation of a services economy depends on many shared models. In a services engagement, models can help minimize risk, maximize fairness, and maximize value capture from deploying new capabilities. Without shared models, large-scale collaboration and coordination in services engagements would not be possible, though some people point to emergent properties of systems as a counterexample (Johnson, 2001). In all of today's services engagements, success depends on getting stakeholders to share relevant aspects of multiple linked models of the engagement. To improve the success rates of services engagements, we need a deeper understanding of models of capabilities, coevolution, relationships, and activities. A core aspect of services science curriculum is an exposition of these models and their causal interconnections, with a view toward improving the success rate of services engagements. This makes the emerging services science discipline more like a design science, similar to computer science, in which systems are built, deployed, and evaluated. The emerging capability of agent modeling will also open up important new doors as simulation tools for complex services engagement become more widely available. The critical work of properly scoping services science depends on choices about which interconnected clusters of models are the essential ones. As Figure 7 outlines, services science must also address data at three scales: macro, meso, and micro.

**Figure 7. The Three Scales of Data in Services Science**

	<b>Macro</b>	<b>Meso</b>	<b>Micro</b>
<b>Technology</b>	Use by industry	Use by organization	Use by people
<b>Business</b>	Economic models	Relationship models	Transaction models
<b>Work Practices</b>	Job types by decade	Skills by months	Activities by minute

Services science will need to solve its data access problem as well as create strong causal interconnections between a small number of key models from related disciplines.

It can rightly be said that six sciences drive new technological capabilities: 1) information and engineering science; 2) social and cognitive science; 3) life science; 4) material science; 5) energy science; 6) environment and space science. Similarly, eleven segments of the economy drive new business needs: 1) information and communication; 2) media and entertainment; 3) financial and legal; 4) public sector (government, defense, education, utilities); 5) medical, health and drug; 6) food and agriculture; 7) consumer, retail and real estate; 8) construction and manufacturing; 9) energy; 10) mining and natural resources; 11) travel and transportation. Fundamental to success in both the sciences and business are relationships between people achieving goals in win-win ways – performance co-production.

Better methods of investing to mature new capabilities (drawn from science) and mitigating risks during deployment (across industries) are needed. The key issue being explored here is the explicit relationship between technology development and organizational evolution. To some extent, the trajectory of technological development is influenced by both scientific progress and economic demand and is modulated by the readiness of workers in organizations to change their work practices and adopt it as well as government policy that supports growth. At the same time, organizational development is enhanced or constrained by the technologies available at any point in time. The coevolution between technology and human social systems is a fundamental subject of study for services science.

An important force in driving the evolution of business and technology is the announcements and product offerings of major IT industry players. For example, IBM, Microsoft, and HP have all announced visions of the future of business that include notions of On Demand e-Business, Agile Enterprise, and Adaptive Enterprise. These are all part of the continued evolution to some postindustrial style of business operation that is yet emerging. Each vision includes a notion of the way business models will be changed (more

sense and respond) as well as what technological capabilities will be needed to support these enhanced business capabilities.

In On Demand e-Business, technology and business innovations coevolve. Rapid business productivity improvements are driven by technology innovations. Rapid technology improvements are driven by business investments. Moore's "law" is as much a law of business investment as of technological possibilities. The two systems – technology and business – ratchet each other up. The characteristics of an on-demand business are that it will be responsive to unpredictable changes in demand, will use variable cost structures and processes, will focus on core competencies, and will be resilient in the face of changes and threats (Haeckel, 1999).

The announcements of top IT industry companies can help spur the growth of the embryonic field of services science. Increasingly, these companies are backing up their announcements with empirical studies and services-relevant statistics. Every consulting engagement and every announcement of new services or products represents an experiment in applied social science. The services scientist welcomes every opportunity to observe such interventions to collect data about the level of successful outcome against hypothesized business or organizational benefits. A specialized form of this kind of investigation would attempt to refine the inventory of known business and organizational characteristics. Such characteristics as "resiliency" or "adaptiveness" would be defined in increasingly precise ways, and a body of experimental literature would be built up around questions of design practices that give rise to one characteristic as opposed to another under various organizational and environmental conditions. Services science would be a design science but would also explore the naturally occurring etiology or morphogenesis of organizations that resists or constrains attempts to design the characteristics we would like them to exhibit.

Finally, a seasoned veteran of many services engagements once said, "A services business must be able to identify capabilities of great potential value to clients, and then develop the competency to sell and deliver those capabilities to multiple clients in a win-win manner." The service delivery life cycle comprises six stages (Chesbrough, 2003):

1. Identify and track the evolution of capabilities with value to organizations
2. Invest in maturing or adapting capabilities
3. Estimate and model the costs and benefits of deploying capabilities
4. Sell and deploy capabilities into organizations
5. Monitor success of deployment (often a co-construction process)
6. Capture value from deployment and reinvest.

As the services economy grows and evolves, we see delivery becoming co-construction, sales becoming co-investment, and identification becoming co-targeting. For a services engagement or service to succeed, the success of all subparts are necessary, leading to win-win value capture and reinvestment so the cycle can repeat.

### **Concluding Remarks: A Call to Action**

Adam Smith's "Wealth of Nations" argued that specialization and division of labor increase a nation's productive capacity. Division of labor has naturally evolved throughout human history. Starting with the observation that convergence and coevolution are processes that expose causal connection between separate systems, and hence in some sense draw them more tightly together, this chapter has offered some initial speculations on the evolution of capabilities as impacted by human and business dynamics. Increasingly, people and businesses provide these capabilities to other people and organizations in the form of services. We noted the rise of a wide variety of services professionals in the information services economy, and hence the rise of availability of services engagement data, as well as a few indications of the emergence of a services science discipline.

We have argued that a services science discipline and profession is needed to more rapidly advance the development and deployment of well-designed capabilities in today's information services economy. In addition to this chapter, we have been developing these ideas through a series of conference dialogues with academic, government, business practitioners, and other researchers such as ourselves. We refer interested readers to related presentations and papers available at a number of event Web sites, including the IBM Research Coevolution Symposium 2003, IBM Research Almaden Institute 2004, and IBM-Berkeley Day 2003, as well as the NBIC Convergence Web sites for 2003 and 2004.

Finally, we believe that action should be taken now to create this new discipline because the work of individuals, firms, industries, and whole economies is rapidly changing. The need for such a new discipline has never been greater, and interest in supporting this discipline is increasingly rapidly. As we have suggested, the potential benefits for improved productivity, quality of life, and economic returns are too great to ignore. As we have demonstrated in this chapter, the basic tools to begin this work exist today but will require identifying appropriate tools and methods from a number of related disciplines and then capturing and analyzing appropriate services engagement data.

In this chapter and in our work, we have set out on this mission. Whether it is called services science or something else, the opportunity lies in capturing and analyzing the growing amount of technology-driven business

and organizational change data to improve productive capacity through more effective deployment of NBIC and other advances.

## References

- Aldrich, H. 1999. *Organizations Evolving*. London: Sage.
- Axelrod, R., and M. D. Cohen. 2000. *Harness Complexity: Organizational Implications of a Scientific Frontier*. New York: Free Press.
- Bardini, T. 2001. *Bootstrapping: Douglas Engelbart, Coevolution, and the Origins of Personal Computing*. Palo Alto: Stanford University Press.
- Benkler, Y. 2002. Coase's penguin, or Linux and the nature of the firm. *Yale Law Journal* 112: 369–447.
- Carroll, G. R., and M. T. Hannan. 2000. *The Demography of Corporations and Industries*. Princeton, N.J.: Princeton University Press.
- Castells, M., and I. Susser. 2002. *The Castells Reader on Cities and Social Theory*. Oxford: Blackwell.
- Chandler, Jr., A. D. 1977. *The Visible Hand: The Managerial Revolution in American Business*. Cambridge, Mass.: Harvard University Press.
- Chandler, Jr., A. D., F. Amatori, and T. Hikino. 1997. *Big Business and the Wealth of Nations*. Cambridge, United Kingdom: Cambridge University Press.
- Chesbrough, H. 2003. *Open Innovation: The New Imperative for Creating and Profiting from Technology*. Boston: Harvard Business School Press.
- Clark, A. 2003. *Natural-Born Cyborgs: Minds, Technologies, and the Future of Human Intelligence*. London: Oxford University Press.
- Coase, R. H. 1937. The nature of the firm, *Economica* 4: 386–405.
- Cohen, D., and L. Prusak. 2001. *In Good Company: How Social Capital Makes Organizations Work*. Boston: Harvard Business School Press.
- Cortada, J. W. 2004. *The Digital Hand: How Computers Changed the Work of American Manufacturing, Transportation, and Retail Industries*. New York: Oxford University Press.
- Davenport, T. H. 1997. *Information Ecology: Mastering the Information and Knowledge Environment*. London: Oxford University Press.
- Davenport, T. H., and L. Prusak. 1998. *Working Knowledge: How Organizations Manage what they Know*. Boston, Mass: Harvard Business School Press.
- Davenport, T. H., and L. Prusak. 2003. *What's the Big Idea? Creating and Capitalizing on the Best Management Thinking*. Boston: Harvard Business School Press.
- Dawson, R. 2003. *Living Networks: Leading Your Company, Customers, and Partners in the Hyper-Connected Economy*. Upper Saddle River, N.J.: Prentice Hall.
- Drucker, P. 1972. *Concept of the Corporation*. New York: John Day.
- Fine, C. A. 1999. *Clockspeed: Winning Industry Control in the Age of Temporary Advantage*. Cambridge, Mass.: Perseus.
- Foster, R. N. 1986. *Innovation: The Attacker's Advantage*. New York: Simon and Schuster.
- Gerlach, M. L. 1992. *Alliance Capitalism: The Social Organization of Japanese Business*. Berkeley: University of California Press.

- Goldstein, J. S. 1988. *Long Cycles: Prosperity and War in the Modern Age*. New Haven, Conn.: Yale University Press.
- Greif, I. and D. Millen. 2003. *Communication Trends and the On-Demand Organization*. Lotus White Paper. Available at [www.almaden.ibm.com/coevolution/readings.shtml](http://www.almaden.ibm.com/coevolution/readings.shtml).
- Guillen, M. E. 1994. *Models of Management: Work, Authority, and Organization in a Comparative Perspective*. Chicago: University of Chicago Press
- Haeckel, S. 1999. *Adaptive Enterprise: Creating and Leading Sense-and-Respond Organizations*. Boston: Harvard Business School Press.
- Hoopes, J. 2003. *False Prophets: The Gurus Who Created Modern Management and Why Their Ideas Are Bad for Business Today*. Cambridge, Mass.: Perseus.
- Iansiti, M., and R. Levien. 2003. *The New Operational Dynamics of Business Ecosystems: Implications for Policy, Operations and Technology Strategy*. Harvard Business School Working Paper Series, No. 03-030.
- Jensen, M. C., and W. H. Meckling. 1994. The nature of man. *Journal of Applied Corporate Finance* 7(2): 4–19.
- Johnson, S. 2001. *Emergence: The Connected Lives of Ants, Brains, Cities, and Software*. New York: Touchstone.
- Kaufman, S. 1996. *At Home in the Universe: The Search for Laws of Self-Organization and Complexity*. London: Oxford University Press.
- Kim, S. 1989. Labor specialization and the extent of the market. *Journal of Political Economy* 97(3): 692–705.
- Koman, R. 2002. *Riding along with the Internet Bookmobile*. San Francisco: Salon.com. [www.salon.com/tech/feature/2002/10/09/bookmobile/](http://www.salon.com/tech/feature/2002/10/09/bookmobile/).
- Landes, D. S. 1998. *The Wealth and Poverty of Nations: Why Some Are So Rich and Some So Poor*. New York: Norton.
- Lesser, E., and L. Prusak. 2004. *Creating Value with Knowledge*. London: Oxford University Press
- Maglio, P. P., E. Kandogan, and E. Haber. 2003. Distributed cognition and joint activity in collaborative problem solving. In *Proceedings of the Twenty-Fifth Annual Conference of the Cognitive Science Society*.
- Malone, T. W. 2004. *The Future of Work*. Boston: Harvard Business School Press.
- March, J. G. 1999. *The Pursuit of Organizational Intelligence*. Oxford: Blackwell.
- MacAndrew, A. 2004. *FOXP2 and the Evolution of Language*. [www.evolutionpages.com/FOXP2\\_language.htm](http://www.evolutionpages.com/FOXP2_language.htm).
- McCorduck, P. 1985. *The Universal Machine*. New York: McGraw Hill.
- McDavid, D. 1996. Business language analysis for object-oriented information systems, *IBM Systems Journal* 35(2): 128–150.
- McDavid, D. 1999. A standard for business architecture description, *IBM Systems Journal*. 38(1): 12–31.
- Mendelson, H., and J. Ziegler. 1999. *Survival of the Smartest: Managing Information for Rapid Action and World-Class Performance*. New York: Wiley.
- Miller, G. A. 1983. Informavores. Pp. 111–113 in F. Machlup and U. Mansfield (eds.), *The Study of Information: Interdisciplinary Messages*. New York: Wiley.
- Murmann, J. P. 2003. *Knowledge and Competitive Advantage: The Coevolution of Firms, Technology, and National Institutions*. Cambridge, United Kingdom: Cambridge University Press.



- Norman, D. A. 1994. *Things that Make Us Smart: Defending Human Attributes in the Age of the Machine*. New York: Perseus.
- Porat, M. U. 1977. *The Information Economy: Definition and Measurement*. Washington, D.C.: U.S. Department of Commerce, Office of Telecommunications.
- Porter, M. 1996. What is strategy? *Harvard Business Review Harvard Business Review* 96(6): 61–78.
- Rheingold, H. 2002. *Smart Mobs: The Next Social Revolution, Transforming Cultures and Communities in the Age of Instant Access*. Cambridge, Mass.: Perseus.
- Roco, M. C., and W. S. Bainbridge (eds.). 2003. *Converging Technologies for Improving Human Performance*. Dordrecht, Netherlands: Kluwer.
- Rogers, E. M. 2003. *Diffusion of Innovations*. New York: Free Press.
- Schumpeter, J. A., and R. Swedberg. 1991. *The Economics and Sociology of Capitalism*. Princeton, N.J.: Princeton University Press.
- Sen, A. 2000. *Development as Freedom*. Peterborough, UK.: Anchor Books.
- Slywotzky, A., and D. Morrison. 1997. *The Profit Zone*. New York: Random.
- Smith, A. 1776 [2003]. *An Inquiry into the Nature and Causes of the Wealth of Nations*. New York: Bantam.
- Spohrer, J.C. and D.C. Engelbart. 2004. Converging technologies for enhancing human performance: science and business perspectives. Pp. 50–82 in Roco, M. C., and C. D. Montemagno (eds.), *The Coevolution of Human Potential and Converging Technologies*. New York: New York Academy of Sciences.
- Thomke, S. 2003. R&D comes to services: Bank of America's pathbreaking experiments, *Harvard Business Review* 81(4): 70–79, 122.
- Watts, D. 2003. *Six Degrees: The Science of a Connected Age*. New York: Norton.
- Wright, R. 2002. *Nonzero: The Logic of Human Destiny*. New York: Pantheon.

## 16. AN ETHIC FOR ENHANCING HUMAN PERFORMANCE THROUGH INTEGRATIVE TECHNOLOGIES

*George Khushf, University of South Carolina*

*Abstract:* New ethical issues arise in the convergence of nanotechnology, biomedicine, information technology, and cognitive science (NBIC). This chapter considers the ethical issues associated with two central features of the NBIC initiative: the accelerating rate of development, and the goal of enhancing human performance. Traditionally, ethical reflection has come only after research and development, and the application of innovations was slow enough that the discussion could be far advanced before their full impact had been felt, but the rapidity of NBIC progress will require ethical reflection at all steps in the process. Many critics and ethicists argue that technology should only return humans to “natural” levels of functioning, rather than give them new or greater capabilities. The Convergence Movement may need to address enhancement directly and make the case for why it could be an ethical goal. The chapter ends with a closing remark on the convergence of the sciences with the humanities.

### **Framing the Ethical Issues**

New technology and change are always accompanied by ethical challenges. The reason is simple: at each stage of history, the ethical norms of human life embody modes of social interaction that reflect an equilibrium in which a given stage of human life flourishes. New technologies disrupt the equilibrium. They make new forms of life possible, and with this, all people are challenged to re-conceptualize the character of human flourishing. This is an ethical challenge: to discover those norms that enable people to flourish within the altered context. Even the manner of ethical reflection evolves with the emerging technology; for example, the technology of writing made possible new ways of organizing thought and society, and with these, the formulation and dissemination of the ethical norms also changed (Havelock, 1963, 1986). Likewise, with the emergence of the printing press (Eisenstein, 1980), and now, the emergence of the computer (Ong, 1982). The more radical the possibilities associated with new technologies, the more radical the ethical challenge, not just to the current norms of human interaction but also to the form and character of ethical reflection itself. At each stage, a new accommodation between the older wisdom and new context is demanded.

The four areas of science and technology contemplated here at this conference each involve radically new possibilities, and with these, radical change and ethical challenge. Each taken individually has spawned its own domain of ethical reflection: the fledgling domain of nanoethics for

nanoscale science and technology (Roco and Bainbridge, 2001; Khushf, 2004b), a decades-old discipline of bioethics for biomedicine and the environment (Khushf, 2004a), a well-established ethics of information technology (Johnson, 2001), and the newly formulated field of neuroethics for cognitive science (Marcus, 2004). Many conferences, journals, and dedicated researchers now focus just upon the ethical issues raised by these emerging technologies, and the depth, character, and scope of this ethical reflection will undoubtedly increase, as the possibilities and challenges of the science continue to emerge and become apparent.

Taken jointly, Nanotechnology, Biomedicine, Information technology, and Cognitive science (NBIC) represent the technological capacities that lie immediately ahead of us. They characterize the possibilities of the world we are entering, and in doing this, they pose for us questions we must ask about the appropriate forms of human community and human flourishing. By reflecting on these technologies, we thus do much more than reflect on some peripheral, esoteric area of cutting-edge science. In the promise of NBIC convergence, we see the promise, risk, and challenge of our future.

There are many ways to outline the character of the emerging future, and thereby specify the content of the ethical challenges. One approach involves the selection of representative areas from each NBIC area: In nano we could explore the forms of manufacturing, energy production, and environmental remediation that are already contemplated; in bio we can explore the next stage in the genetic revolution, whether for understanding human health or engineering agriculture; and so on for questions of human identity in cognitive science, and human cognition, communication, and interaction in information technology. Bringing together the diverse developments and ethical issues in each of these four domains gives us a nice account of the world that lies ahead, and it enables us to understand how life in virtually every area will be transformed. That by itself would be a valuable way to initially frame the ethical issues of NBIC convergence. But it is not what I will do here.

Instead, I want to consider what is uniquely associated with the convergence initiative itself; namely, this initiative for enhancing human performance that arose out of the initial 2001 NBIC workshop (Roco and Bainbridge, 2003; see also Roco and Montemagno, 2004), and of which this conference is a continuation. I suggest that this initiative represents something new and that, by considering the ethical issues it raises, we constructively engage and formulate the ethical capacities that are going to be necessary for that new world we are now entering.

So what is unique about this current NBIC convergence initiative? The areas of NBIC are jumping together everywhere, and we surely do not need a conference to bring this about. Nano would be unthinkable without information technology; cognitive science depends in many ways on biology,

especially the neurosciences; and so on for the multiple forms of interaction between the diverse NBIC domains. Whether or not we have the current initiative, the domains will continue to converge in multiple, complex ways. Taken jointly, they will still serve as a useful characterization of our emerging technological capacities and the ethical challenges that lie ahead. To get at what is unique about this book and the NBIC convergence initiative, we thus need to go beyond a mere description of the ways these technologies jump together and explore the reasons why a more sustained public/private partnership is advocated here.

Among the reasons for a formal NBIC initiative given in previous workshops and conferences, two are especially prominent (Roco and Bainbridge, 2003, esp. pp. 1–23; Gingrich, 2003). The first concerns the rate of development: by seeding the convergence in the appropriate way, we can significantly accelerate the rate at which each individual NBIC domain advances, as well as the rate at which the four domains are integrated. Such acceleration of the rate of development is desirable for several reasons, including the advancement of scientific knowledge and the overall economic productivity of our nation. These, of course, are the motivating goals of the federal agencies that would sponsor this initiative, as well as the industries involved as collaborating partners. The second core reason provided for the NBIC initiative concerns the specific end of “enhancing human performance” that guides the integration: By channeling these emerging technologies for the end of human productivity, we can guard against some of the adverse impacts associated with a more haphazard development. The enhancement goal is thus linked to a broader concern with human flourishing.

### **Accelerating the Rate of Development**

Several speakers at the earliest NBIC events have rightly noted that the proper cultivation of convergence rapidly accelerates the development of all domains involved (Roco and Bainbridge, 2003; Roco and Montemagno, 2004). The question is: What things are necessary for seeding this convergence? Beyond the obvious answer of having conferences that focus on the emerging areas, raise the problems, and form a community of interested people, several other recommendations have been advanced: resources are needed for the groundbreaking work, disciplinary and institutional obstacles need to be overcome, and the development of a framework for integrating knowledge across scales and data modalities is required.

Embodied in all these recommendations is an important insight: areas of research and development (R&D) have their own momentum, and work is needed before new forms of integration are established, with their own momentum. Put in other terms, trading zones must be established. To

accomplish this, a critical mass of people is needed and important bridge-work research must be developed. Thus, economic, cultural, and institutional conditions are required. When these are established, all of a sudden the convergence takes off, with an explosion of interest, research, and commercial development. Behind the idea of “seeding” is the idea that you need to cultivate the culture, overcome the initial obstacles, form sustaining institutions, and get a certain group of people working together with each other and with industry. At the beginning this is a difficult process, involving an input of energy and resources. Once it ignites, however, the convergence is exothermic – the rapid generation of new research and production, with extensive scientific and economic benefits to all involved.

The effect of convergence on ethics will be the same as on the rate of technological and scientific development – multiplicative, rather than additive. When research and production ignite, so too will the number, depth, and scope of issues that demand ethical analysis. The reason for this is simple: new technologies, which significantly enhance or challenge current human capacities, also challenge the ethical equilibrium, and thus the norms that have previously been configured for individual and communal interaction. The more radical the technology, the more radical the ethical challenges, and there is every reason to expect that the kinds of advancements associated with the NBIC technologies will involve such radical ethical challenges; in fact, in these domains, the ethical issues are already highly visible.

My point, however, is not simply that we can expect many ethical issues to arise out of NBIC convergence. There is a deeper, more complex problem associated with the accelerating rate of development. We are already approaching a stage at which ethical issues are emerging, one upon another, at a rate that outstrips our capacity to think through and appropriately respond. Whether we have already reached this stage or not, I am not sure, but of this I am certain: On the immediate horizon arises a point at which the traditional way we have addressed ethical issues fails, because it does not and cannot keep up with the rate at which new challenges emerge. Faced with the prospect of increasingly accelerating, radically new technologies, we must completely reassess how ethical issues are addressed and how ethical debate informs broader public and legal policy. The promise of NBIC convergence thus poses an ethical challenge not just in the number, scope, and depth of issues that are raised but also in the very form that ethical reflection takes.

To fully address this concern goes beyond the scope of my current argument, but I would like to say a little more about the form that current ethical reflection takes, how this is challenged by the accelerating rate of development, and where I think we need to go, in order to form those capacities of ethical reflection that are needed for our altered context.

First, to illustrate the current form that ethical reflection takes, I use the example of genetically modified organisms, drawing on some discussions I have had with people in industry about how they proceeded with the development of their products. The general model goes something like this: First you have research on fundamental science, for example, recombinant DNA work, with new capacities arising for application in industry. With the exception of areas in which there is great and obvious danger to human life or the environment – for example, genetic manipulation of a pathogen so that it is resistant to conventional drug therapies – little ethical reflection takes place at the early stages of research. Although concerns related to research ethics are integral to the culture of the scientific community (and increasingly emphasized), this usually involves topics like falsification of data, animal or human subjects research, and so on. There is usually little work, training, or interest in exploring the possible ethical issues that might arise from the research. With some exceptions, the same is generally true for the movement from research to development; for example, the development of new, genetically modified plants, which produce higher, more resistant yields.

Many in industry simply assumed this is a good thing – actually, I think it is a good thing too. But that is not the point. The issue here is not whether it is good or not but whether those involved in R&D take the time to reflect on the kinds of concerns and issues that are likely to arise at a later stage and incorporate them into broader reflection and strategies associated with R&D – and to not just do this as a component of public relations and marketing, with an interest in bypassing public objections. This kind of reflection has simply not been part of our R&D culture, a point that has often been confirmed to me when I have discussed these issues with those in industry and asked them about whether they consider ethics at an early stage. In fact, many have told me how they were completely dumbfounded with later developments – for example, reactions against GMOs (genetically modified organisms) – and how they never even thought of asking ethical questions at an earlier stage. Only later, as the new developments come into the public view, does the broader ethical reflection begin. Then we have a complex combination of more academic ethical reflection (often associated with different schools or traditions, for example, environmental groups versus researchers in agriculture, exploring the ethical issues arising from GMOs in different ways), media, public and political discussion, and so on.

To summarize, our conventional model of ethical reflection involves two steps. First, we have R&D, and then second, at a later stage, we have *post hoc* reflection on the ethical and social issues raised by the new technology, and we assume radically different and disconnected interests associated with these steps. The interest of scientists is in new knowledge and in novelty. Industrial development and marketing involve commercial interest; namely, profit. The engines of science and commerce are thus seen as distinct in

genesis and interest from the various individual and social interests that assess the use and abuse of the attendant technology. The broader social interests come in after the R&D stage, initiating a risk assessment, and subsequent regulation. Further – and this is an important point – the post hoc ethical reflection involves a lengthy, complex process in which genuine understanding is facilitated and consensus is formed regarding the most responsible norms and policy.

Although this two-step model is somewhat of an oversimplification, I think it does express the broad lines of how we have traditionally explored ethical issues and how we expect to continue addressing them; for example, when we consider new developments in NBIC areas, we generally expect that science will continue to push the envelope, with radically new capacities emerging, and then we will struggle with how to incorporate these into our lives and community. However, as should be clear from the account I just provided, this process is generally slow. Although we are getting better and faster at it – new technologies of communication, in fact, make this possible – the process has intrinsic limits, based on the assumptions about consensus formation integral to it and, more significantly, based on the assumption that the significant ethical work follows the initial process of R&D. As new – radically new – technologies with tremendous capacity to alter our lives come online faster and faster, we soon lose the capacity to reflect upon them in this secondary way. If, indeed, as many argue, the rate of acceleration is exponential, somewhere along the rising curve the current process of ethical reflection becomes completely inadequate. By the time ethical debate gets going on a given, new technology, that debate and the technology itself have been outstripped by the next one, even more radical in its implications.

In the end, I do not think our primary worry is that we will not be able to put the brakes on the technology, and that some technological anarchy will lead to the destruction of our world (Joy, 2000). In fact, my tendencies tend to be in the direction of research, development, and a free market, and thus I am usually less scared about the developments in these arenas than I am about inappropriate kinds of external intrusion and constraint, especially those intrusions in which the coercive arm of the state monopolizes the technologies for its own ends. Decentralization leads to important checks and balances. However, when it becomes increasingly apparent that there has been insufficient ethical reflection and oversight of new developments, I think we risk a major public reaction; already, some argue that all new developments need to be vetted through some kind of bureaucratic oversight mechanism that approximates our traditional processes of ethical oversight (ETC Group, 2003). I think this is, in fact, what we saw with the reaction against GMOs in Europe: there was a vague public sense that the new GMO technologies were somehow radically different, and that some kind of vast regulation and constraint was necessary, preventing even the smallest

introduction, and demanding extensive new testing and oversight before, on a small scale and guided by a precautionary principle, before we allow gradual introduction. If this becomes our model, then the external method of oversight, with its precautionary principle, will become an intrinsic limit on the rate of growth of science and technology, as well as the economies that are now so closely linked to these research domains. More significant, we will lose the decentralized mechanisms of checks and balances that guard against monopolistic abuse of emergent technologies.

Put in another way, the rate-limiting step in the emergence of radically new integrative technologies will be sociocultural and ethical, not scientific or technological. If we cannot develop new processes for reliable modes of ethical reflection – and by this, I mean forms of ethical reflection that embody the interests, concerns, and modes of reasoning that currently come in as a secondary, external step – then we face a sociocultural barrier to the rate of acceleration in NBIC domains. This is something that should be addressed now, at the beginning, as a part of initial formation of the culture of NBIC convergence, and it should be addressed for two reasons.

First, and primarily, it should be addressed for ethical reasons: We need to be able to responsibly reflect upon and address the ethical issues that arise and to address them in a way that reflects the kinds of concerns that come into play as a part of a broader social debate. Second, and here I come directly to the reasons that were initially given for seeding the NBIC convergence initiative, we need to address these issues, if we really want to see the explosion in R&D that is anticipated. In other words, if we want to consider what is necessary to seed explosive development, then in addition to the other things organizers have considered such as the formation of a community of researchers and institutional support mechanisms, we also need to consider an alternative to the traditional ways we have approached ethical reflection.

Now to my constructive proposal: Just as we abandoned the older model that says “first basic science research, then applied research and commercial development,” so now we also need to abandon the model that says “first research and development, then ethical reflection and policy.” In fact, this outmoded approach to ethical reflection, which assumes a neat fact/value split, depends on the older model that distinguished a pure, value-free science from the applied work, where values came in through the goals that directed the application. We need to develop a culture of scientific research and commercial development in which ethical reflection is integral at every stage, and the intellectual and social capacities of ethical reflection become a part of the training and apprenticeship and culture and institutions of R&D. Only when this is accomplished, and when it is done in a way that reflects the kinds of concerns associated with the current, secondary process of ethical reflection, will we remove an intrinsic barrier to the rate of development of



science and technology. Only then will we develop the cultural and intellectual capital that enables us to develop these radically disruptive technologies in a responsible way.

Of course, this is a fairly radical change, requiring a bridging of the classical two cultures divide (Snow, 1959). I think there are some clear ways in which we can move toward this goal, and much of my research in bioethics and now nanotechnology focuses upon how we might accomplish this shift. To discuss it is beyond the scope of this chapter, but I suggest that we are already seeing some areas in which we are moving in this direction. Some of those same people I discussed earlier, who said that they did not even think of addressing the ethical issues at an earlier stage in their development of GMOs, now have altered their initial process of development so it incorporates ethical reflection in the early stage. As one person put it to me, "We got hurt, and we've learned our lesson." The cynic can say this is just a public relations and financially motivated move – so they do not get hurt later, they now reflect on potential public reaction when first considering whether to develop a new area – and perhaps this is true in some cases. But note that the same capacities involved in understanding and accounting for public reaction are also those capacities that are required for the ethical work itself, and I do believe that some in research and industry do take very seriously this ethical concern, and they have begun to think through these issues as a part of their own research pursuits. Similarly, we have some precedents, for example, in early recombinant DNA work, with their advisory commissions, where the public gained confidence that the scientific community was addressing the ethical issues in a responsible way (Evans, 2002). Although each of these examples points to but a small part of the broader transformation needed, we can see it emerging, in bits and pieces, and the task is to more fully integrate it as an integral part of the developing culture of R&D.

Here, I think, is a special opportunity we have with NBIC convergence. Earlier I mentioned that the domains that come together – nanotechnology, biomedicine, information technology, and cognitive science – represent our future, and they do this in the character of the science and technology they embody, the depth and scope in which they open a new horizon and challenge our current norms, and their accelerating rate of development. Their convergence is a testing ground for how physical, biological, and social sciences may themselves converge. If we now consider the ethical challenges they pose, not just in number and scope but also to the very form of ethical reflection, then we see another way in which the convergence initiative can embody our future, and we, in fact, have an opportunity to configure that future in the process.

By developing an alternative to the traditional modes of ethical reflection, in which the values debates are secondary to the science and

commercial development, we play a central role in configuring a more responsible future. To do this, yet another kind of convergence must take place: the physical, biological, and social sciences need to themselves converge with those forms of life and culture in which the questions of value are addressed in a normative, rather than purely descriptive, way; this is the domain of reflection traditionally associated with the humanities: history, literature and languages, religion, and philosophy. These two cultures that have been separate and distinct, often in tension and even opposition, mistrusting and constraining one another must themselves be bridged, and a third culture must emerge as a part of the condition of NBIC seeding itself.

I admit this sounds somewhat utopian, but is it any less utopian than a call for a “framework for integrating across all scales and data modalities” and the call for integrating the sciences and humanities, which was already set forth as a fundamental challenge for NBIC convergence in the first workshop? Here I am simply suggesting that some of the features of this framework and integration emerge from reflection on the core ethical issues, especially the form of ethical reflection that is necessary to responsibly account for and sustain the hoped-for accelerating rate of development of these technologies. Here the character of the task, and the opportunity to craft the future we now enter, all come into view. Appropriately understood, the NBIC initiative does not just drive into the future, with engines of science and industry running full throttle; even beyond this, NBIC convergence, with a newly developing form of ethical reflection, can responsibly lead into a future, where the engines of growth are also the engines of self-regulation, reflection, and mature governance.

### **Enhancing Human Performance**

Thus far, I have considered the accelerating rate of technological development; how this poses ethical challenges in both number, scope, and most significant, the very form of ethical reflection; and how the goals of scientific advancement and commercial development themselves require ethical reflection if they are to avoid a kind of intrinsic limit to their rate of growth. In all this, however, we have not yet come to a very interesting and important feature of the larger NBIC convergence initiative; namely, the goal of “enhancing human performance.” How are we to understand this goal?

#### *The Goals of Technological Development*

Sometimes, in earlier discussions, the goal of improving human performance was advanced in a very general, unspecified sense, as if it were equivalent to benefiting human life. How else could it include things as varied as sustainability, energy production, and extended life span? Viewed

in this way, the earlier goal of accelerating scientific knowledge and commercial development, with its benefit for the economy, may even be conflated with the goal of enhancing human performance. On one hand, science, technology, and the commercialization that follows are seen as good, because they are integral to economic development in the modern world. Those who want to see a sound economy and, with this, good jobs and a promising quality of life are thus wise to advance the R&D. When seeding science, and when establishing the needed infrastructure, these are the goals that often come into view, as they do, for example, in some documents and presentations that have been made on the value of NBIC convergence. In these technologies, we see promising engines of a sound future economy – the next wave following the information technology revolution.

However, there is also another, more significant, way in which science and technology are valued. They are not just means to a sound economy but are also integral to the very formulation of certain goals that could not otherwise be realized or even imagined. Without science and technology, we could not have gone to the moon, built a telephone or plane that links people far away into a global community, or extended to the multitude the joys of music or theater, which in the past were only accessible to the rich. Certain visions of exploration, community, and social equality only emerge together with the new technologies. Further, science and technology are valuable not just as means but as ends themselves: They embody a form of knowledge and way of exploration, which itself realizes some of the highest excellences of the human spirit, providing us with insight into ourselves and the rest of the world, as well as a capacity to realize our interests within that world.

When we focus on the economic and development concerns that are often featured in political and public policy discussions, science and technology are simply means for realizing something that is really external to them. The wealth, good jobs, and quality of life are seen as what is valuable, and when one asks what such wealth or quality of life entails, the answer is unpacked in terms that have nothing to do with the science and technology at issue. We use, for example, purely economic terms: kinds of jobs, income, number of start-ups and patents, and so on. However, when we bring into view those other ends, which are more intimately linked to the science and technology, then it becomes impossible to discuss the goals without also exploring the character of the science and technology at issue. If you ask about going to the moon or exploring Mars, the whole configuration of rockets, space suits, and command and control centers – linked in complex communication and information processing systems, and entering into a new era in which humans live on other worlds, with homes of tubes and domes and self-sustained ecosystems, all comes into view. The goal, the knowledge, and the technological means all are intertwined with visions of how human life transcends itself and flourishes. It is only here, with this deeper reflection

on science and technology, that we can fully appreciate how new developments challenge current notions of human flourishing, and why the ethical issues come forth as central, concerned as they are with the character and norms of that flourishing. Here we move from general discussion about number, scope, and form of ethical reflection – as we saw in our earlier discussion about rate of development – to the explicit content and substance of ethical reflection and, with this, the character of human enhancement and flourishing at issue.

*The Controversy about Enhancement: A Clash of Two Cultures*

What kinds of enhancement or improvement of human performance are we contemplating? We need to answer this question before we can address the ethical issues. Are we concerned with pharmaceuticals for the enhancement of memory, attention, or mood? In this case, specific ethical issues arise; for example, the relation between the pharmaceutically enhanced trait and personal identity, or the unfair advantage Ritalin use might provide on an entrance examination, or perhaps whether these things alter personality, as well as enhancing capacities. Or we could discuss brain-machine interfaces, with which the mind could directly control a robotic arm or, perhaps, by thought surf the Internet. Perhaps we could discuss the extension of the human life span by 50 year, genetic engineering, smart environments, or space exploration. In each case, different notions of human flourishing are evoked, and different kinds of ethical issues arise.

The goal of NBIC convergence – namely, enhancing human performance – does not have a specific content unless we also consider in detail the science and technology involved. Both goal and means are jointly informed by and also entail a specific notion of human flourishing. We thus need to consider the full set of proposed technologies and try to understand how they fit with a larger vision of human life. There will, of course, be controversy – the controversy about human flourishing is inseparable from the broader ethical debate. In fact, the best way of framing that ethical debate is to see it as one about the character of such flourishing and about the implicit and explicit norms that should govern those individuals and that community, where such flourishing is realized.

Curiously, the controversial character of the enhancement goal, and the way this goal and the proposed means are intertwined with specific notions of human flourishing, have not been featured as a central concern in earlier NBIC conferences. However, in public reports and outside conferences, and especially in European debate, this concern with human enhancement has been a central feature of commentary and criticism on NBIC convergence. There is thus a major difference between the internal reflection of NBIC convergence, which focuses upon the science and the institutional and

economic means for sustaining that science, and the external debate, which focuses upon the ethical issues. This division reflects that older way of addressing ethical issues, which we need to get beyond. It is, in fact, a variant of the older two cultures split. To appropriately frame the ethical issues, and to make ethical reflection integral to the culture of NBIC convergence, the debate needs to move from one of outside criticism and rejection of the initiative into an internal discourse about the nature and character of the enhancement that serves as an appropriate end of NBIC convergence. As an ethics commentator, I thus take as my role the introduction of this debate into the core discussion and culture of the convergence initiative, and I will thus provide some suggestions – themselves controversial and only a “seeding” word – on why we should, indeed, pursue the enhancement of human performance, and how such a pursuit should be advanced, so that the concerns of detractors are responsibly addressed.

*Further Refining the Controversy: Medicine, the Therapy/Enhancement Distinction, and the Affirmation of Natural Norms*

NBIC convergence for human enhancement is analogous to medicine: both involve the organization of basic sciences and technology for the purpose of augmenting human form and function. In medicine, the end is therapeutic – to cure disease, preserve and promote health, reduce the rate of functional decline in areas where conditions are chronic or disease untreatable, and provide prognosis and palliation where no other help can be given. NBIC convergence moves beyond the therapeutic end and seeks to extend, rather than simply sustain, species typical functional abilities.

On the basis of medical ends, many have attempted to draw a clear line between therapy and enhancement, restricting the use of technological means to the former (Parens, 1998). This approach has been very influential in recent debates on genetics, in which many celebrate the use of recombinant DNA technology for purposes of therapy, but they strongly reject its use for enhancement. The reasons for rejecting enhancement are instructive for our purposes, although we can explore them only in the most cursory way. Presupposed by the therapy/enhancement distinction embodied in much of medicine and the law is the assumption that science and technology enable us to overcome threats to the natural form and function but that they can also be a threat to such natural form and function. The idea is that there is some biologically based and discerned “human nature,” and that when we try to alter this by technological means, there is actually a distortion and disruption of the individual and society, and a delicate complex balance necessary for flourishing is undermined (Fukuyama, 2002).

This assumption is found in areas such as competitive sports, where many attempt to exclude enhancement drugs because they are thought to

distort what sport, and the excellence realized therein, is all about. The assumption is also found in many environmental initiatives, where it is assumed that the natural ecological balance is good and to be respected, with significant limits placed upon technological alterations that might disrupt the subtle equilibrium that characterizes life. There is thus a confluence of medical, social, and environmentalist assumptions about the problematic character of enhancements. Such a confluence is clearly seen in writers such as Leon Kass (1985, 2002) and Frances Fukuyama (2002) of the current President's Council on Bioethics, and their views are advanced in the recent report of that council, criticizing enhancements (President's Council on Bioethics, 2003). Kass, in fact, has written on these ideas of natural form and function, and the limits of medicine, since the 1970s, when he argued for a biologically based disease concept and medical goals that were restricted to the therapeutic arena (1985). Bill McKibben (2003) and ETC Group (2003) are among those who would take a similar view on environmental matters, framing through their precautionary principle a heavy burden of proof on anyone who would introduce something new that might disrupt the natural equilibrium. Greenpeace, by contrast, takes a more balanced approach (Arnall, 2003). Absent from the writings of McKibben or ETC Group is any discussion of how science and technology are at the heart of economic growth and development, and the role they legitimately play in configuring both the ends and means of current human activity. When pushed, I'm sure they would appreciate that these things do play an important role, but in ethical analysis, these things are not made central. The way the goal and background context are understood thus frames the key ethical issues that emerge.

#### *Facilitating Communication and a Strategic Choice*

Obviously, in debate and controversy about the goal of enhancing human potential, we see a clash between two very different visions of science and technology – human nature flourishing versus economic development – and the way we should regard the current equilibrium of human and natural life.

The external criticism of the NBIC initiative is closely linked to the therapy/enhancement distinction drawn from medicine or assumptions about environmental health drawn from green initiatives, and it seeks to limit new technologies, so they sustain the current equilibrium of life, rather than disrupt it. In medicine, such a limited goal is called therapy, guarding against the disruption of species-typical functional ability associated with disease. In environmental areas, such a limited goal is associated with “sustainability,” a term that is understood by environmental groups in a much broader sense than it is among those in industry. However, when we move to the internal

assumptions about enhancement associated with the NBIC initiative, we find something very interesting; namely, the therapy/enhancement distinction plays almost no role at all, and many things that are called “enhancements” would actually be called “therapy” by the external critics.

Within the NBIC initiative, we find embraced activities that are both controversial and completely uncontroversial when assessed according to the categories and concerns of the external critics:

- **Controversial areas:** There are several areas of NBIC convergence that are clearly associated with what critics call “enhancements.” These include radical extension of aging, brain/machine interfaces, surgical or pharmaceutical enhancement of beauty, cognitive ability, and genetic modifications of animals and agriculture, just to mention a few examples.
- **Uncontroversial areas:** However, there are also many areas that, although associated with the “enhancement of human performance,” are not very controversial, and that many would not even call “enhancements.” These include the development of new medical therapies – a prominent area of the NBIC initiative – organizational enhancements for more productive teams and companies, new forms of energy, and environmental sustainability and remediation.

The uncontroversial areas are not mentioned by outside critics, even though they are a major feature of the NBIC initiative, and the therapy/enhancement distinction integral to the formation of external criticism is not mentioned within the internal documents of NBIC convergence. It is thus clear that architects of the initiative have in mind a notion of “enhancement of human performance,” that does not arise out of the same assumptions as those found behind the therapy/enhancement distinction. There is a clear disconnect between the external and internal debates that have emerged. This disconnect reveals two major challenges that are integral to the broader task of appropriately framing the ethical issues: one is a challenge to establish a framework for understanding and communication between external critics and internal advocates, and the other is a strategic challenge associated with the ends of the broader initiative.

First, there is a communication problem, which arises out of the core background assumptions people bring to the discussion. One side values the natural equilibrium, with its norms of human form and function presupposed by medicine, and somewhat more difficult to specify but nevertheless directive norms associated with social and ecological health. On the other side, there are those who see science and technology, economic development, and the opening of new horizons as all central to human flourishing and thus ask how such advancements might take place. Before constructive

engagement can take place between these sides, we need to make explicit the background assumptions and form a culture of shared understanding and exchange – trading zones (Gorman, 2003, 2004) – in which genuine communication can take place, rather than simple rejection, disregard, or unproductive confrontation. We really have two discussions that are external to one another. If this situation continues, the positions and debate will increasingly polarize. The more this happens, the more we lose the opportunity to configure a richer engagement and a collaborative future. The first challenge is thus to establish this more constructive debate.

Second, it is clear that there is a strategic choice that must be made by those who craft the NBIC initiative – one that will, in the next few years, become more apparent as the external criticism of enhancement becomes more vocal and the debate more polarized. Because some of the areas of NBIC convergence are controversial and others are not, do organizers step away from the more controversial goals to avoid public controversy and thus ease the road to industrial and governmental funding? This is a common strategy, and one that is often successful – move away from areas that are contested and reframe the goals so that broad consensus and support can be obtained. In other words, put off the difficult parts of debate until a later time, when you have already gotten the initial funding and infrastructure in place. In this case, you allow the external critics, with their therapy/enhancement distinction, to frame the appropriate domain, and you advance that “common goal.” Here the “limits” are analogous to legal constraints – they are purely external from the perspective of the advocates. Ethics comes in as a limit on what science can do, but the limit is the result of *ad hoc* political negotiations, rather than a deeper internal regulation of the practice. Although ethical norms are often viewed in this way – as constraints that keep people from doing certain things they want to do – that is not the most helpful way to understand ethics. It would be far better to move toward a context in which ethics and the norms that configure practice are understood as the form of internal regulation that leads to the flourishing not just of the specific practice in question (e.g., research, commercialization, etc.) but of the community as well.

Two different kinds of debates and initiatives emerge, depending on how we approach this strategic choice. Do we seek to diffuse the controversy, set the initiative in the context of established goals, and pragmatically work to advance the funding, infrastructure, and processes of commercialization? Or do we affirm the controversial goal of enhancement and explicitly facilitate the debate that thus emerges, seeking to move the scientific community, industry, and the public to reflect on these goals? If we take the second approach, much more energy will need to be directed to the debate about the enhancement ends, and it is likely that the initiative, at least in its earlier phases, will be more sluggish in realizing its ambitions. Is the



effort directed to such “ethical controversy” worth the time, energy, and resources expended? What will be the gain? How important is the enhancement goal – at least in its controversial form – to the NBIC initiative itself?

The answers we give to these questions are strategic, guided in part by pragmatic considerations, but I want to suggest they are not just strategic – they are also ethical, and I think that for ethical reasons as well as long-term (rather than short-term) strategic reasons, we should not shy away from the enhancement goals but, rather, explicitly advance them and, by doing this, work to form the right kind of debate about enhancement; namely, work toward forming a debate in which the norms that configure practice arise out of a richer kind of internal discourse, and thus are advanced as a way for the practice to flourish, rather than as an external and inhibiting constraint.

*Rightly Framing the Debate about the Enhancement of Human Performance*

Anyone who reflects on the accelerating rate of scientific and technological development, and who considers the kinds of knowledge and capacities now emerging – for example, the kinds associated with NBIC areas – is compelled to acknowledge that we are on the cusp of a radically new world. By this, I do not just mean we will face new challenges, as others have faced them in the past. In the last century – a tiny blip in historical time and an indistinguishable spot in geological or evolutionary time – humanity has changed more radically than it has in its whole previous history, largely as a result of scientific and technological developments. The globe has shrunk, all people are linked in vast networks of communication and economic interaction, and human capacities have already been enhanced in ways unimaginable just a century earlier. To give just one example, we moved from having a maximum speed on the order of animals in the natural world to one that is now greater than the relative motion of bodies in our solar system. These kinds of enhancements were fueled largely by the physical sciences: cars, rockets, cell phones, and computers. With these sciences, we could sustain the notion that the technology was somehow external to us, enabling us to accomplish our personal ends, but not altering that person or framing those ends. The human sciences – especially medicine – also grew but were harnessed for therapeutic, rather than enhancement, ends. Now, however, for many reasons, we cannot any longer sustain neat lines between these domains of physical and biological science, between means that are “external” and those that transform our most basic capacities. The knowledge of our world converges at multiple levels, and the tools of one domain are also those of the other. In all this, the rate of development continues to accelerate. A decade brings the change the previous century did, and soon a year will bring what a decade now does.

Unless we all, right now, take the way of the Amish (as McKibben, 2002, suggests), putting aside the institutions of research and technology, as well as our whole economy, in a few short years the developments will be so rapid and so radical that we will be forced to address them in terms of a qualitative transition and radical enhancement. Unavoidably, the convergence of seemingly “conventional” domains of science and industry will lead to a qualitative alteration of human capacities. We might delay this a little. With growing public concern, and with a few visible examples of catastrophe – which are likely to happen – we might get broad public support for some sweeping regulation. I spoke of this earlier as a kind of inhibition and constraint on the rate of development, which I think may arise, but it will only forestall – not prevent. Whether 20 or 50, or say even 100 years ahead, we will enter that new world, and think of how small that timeframe is – even 100 years – especially in the formation of cultural and ethical norms. The question is then, Will we have this debate now, and seek to form the character of that enhancement in a responsible way; or will we shy away from the debate, only to see it emerge shortly, perhaps in a less appropriate form?

Put simply, I think we should advance the goal of enhancing human performance and consider how the goal should be configured. We should responsibly consider what the future soon brings, honestly and openly facing the challenges ahead. In saying this, I do not mean to say we have no choice or that the engine of technology unavoidably brings us in a certain direction, as Kurzweil (1999) and others imply. To the contrary, because we can play a role in crafting that future, we need to openly confront it and address what lies on the horizon. One option is to renounce all further advancement. I do not think this is possible or desirable. The question is thus not “whether,” but “when,” and more important, I think we should ask “how” and “what form should this enhancement take?”

Summarizing, the reason why we should explicitly advance the goal of human enhancement is that we are going in the direction of enhancement whether we like it or not, and we must explicitly address the issues that arise. In fact, this goal emerges naturally out of the developments taking place in NBIC areas, and the convergence initiative is a natural place to take up this challenging debate and task. If, to avoid controversy, we step back from that goal, we still move ahead with the knowledge and technology that make enhancement possible, but we forestall the important ethical debate. Consider, for example, brain/machine interfaces. Yes, at the beginning it will have a therapeutic value – enabling blind people to see or the paraplegic to walk – but the same video glasses on that blind man, with a line into his brain bridging neural and digital worlds, that also enables him to link through a small cell phone with other blind people simply by thought, produce not just a restoration of sight (therapy) but radically new forms of knowledge and

interaction (enhancement). Then, as a next step, those digital/neural interfaces enable another person – who is not blind – to have a new form of control over the hardware of war. Isn't this why DARPA is funding work on these brain/machine interfaces? The paraplegic who can interface with robotic arms or legs that restore lost function could also have the power of a fork lift, simply by upgrading the machinery. Such examples could be multiplied endlessly. In them we see the therapy/enhancement distinction breaking down not just theoretically, but in practice. Soon, we will no longer be able to meaningfully sustain it at all. We already see this happening at the end of life, where the "species-typical function" for a given age has been radically altered. These changes spread to all of life, and to the natural world as well, challenging even the distinction between natural and artificial, as well as any notion of a sustainable balance or equilibrium.

Given that we must have a debate about a future that already is taking form, now is a good time to begin. If we can form this debate responsibly, together with the technologies that make the enhancements possible, and if we can see a culture of ethical reflection emerge as a part of R&D, we are empowered to enter that future with a capacity of self-regulation and control that can channel new capacities so life flourishes. If we cannot have the debate, if we fail to develop these capacities for self-regulation and instead polarize, so that ethics is external to the life of research, then the future will still come – perhaps a little later, but now in a less appealing form. Thus, instead of downplaying the more radical features of this NBIC initiative, we should advance them. Instead of assuming current consensus about goals and orienting convergence to realizing them, we should seek to form a new consensus, asking how enhancement should be understood, and what forms such enhancement should and should not take.

In the end, I think there are fields in which we can carve out new areas of consensus. We will end up with new middle-level principles; for example, "when invasive bodily procedures are utilized for enhancements, one should always use the least invasive and most reversible means compatible with achieving the desired effect." (Probably the ideas of "invasiveness" and "reversibility" are intertwined with some reservations about enhancements, which is why external tools like cell phones are not viewed as problematic, but an implant that provides the same capacity is.) Then, of course, you will get all sorts of additional debates about what is invasive, or how you trade off the "invasiveness condition" and the "reversibility condition" if these cannot simultaneously be realized, and so on. Beyond these kinds of principles, we must also have a broader public debate about the conditions for human flourishing and about the character of that flourishing.

In order to craft this new consensus, and thus configure the new technologies – for example, to make less invasive, reversible enhancements – the objections of those who are concerned about enhancements need to be

understood. Without appreciating the arguments against enhancements, you cannot develop new enhancements that are responsive to the concerns embodied in those arguments. That is why the opposition needs to be incorporated into the debate.

Consider, for example, one common argument against enhancements: When some are given enhancements, they are provided with an unfair advantage in competitive contexts, and all are pressured to use them, even though most would prefer not to use them. This is an argument integral to many criticisms of enhancement drugs in sports, and it has been advanced in the larger public debate; for example, regarding the use of stimulants for enhancement purposes (Parsons, 1998).

The criticism presupposes that enhancement of one area may lead to diminishment in other areas. One can find many examples of this: an SSRI that enhances mood may simultaneously diminish sexual function, or in sports, enhancement of one athlete puts the other at a disadvantage. If, however, one could find areas of enhancement that simultaneously advance the interests of all or that do not involve the trade-offs presupposed by the criticism, then the whole argument is sidestepped. The argument gets transformed into a principle to guide the development, rather than prevent it. As these kinds of guiding principles and ideals are formed, they can be used by the researchers and industry to craft the enhancements. In other words, they become tools of R&D, assisting researchers and industry in developing those enhancements that best advance human flourishing. Instead of an external constraint, the norms become a part of the inner life of the research enterprise. Instead of providing the scientists with an incentive to get around the external constraints, you provide them with an incentive to use their great, creative minds to find ways of developing enhancements that embody exactly those concerns that now motivate the rejection of enhancement. That is the form that ethical reflection should take.

### **Ethics, Freedom, and Knowledge**

I have now considered two aspects of the NBIC initiative: (1) the accelerating rate, and why this requires a new form of ethical reflection, and (2) the enhancement goal, and how this should be advanced. Both lead to the same conclusion: ethical reflection and debate must be made a part of R&D. Two worlds – often separate and external to one another – must now be reconfigured, so that they are intimately intertwined. Put in another way, we need to bridge the culture of the sciences and the culture of the humanities.

This bridging is not easy, as the tasks and goals, as well as the language of discourse, are radically different. Scientists tend to view ethics in scientific terms. Ethics is then transformed into a kind of risk assessment, which serves to advance quantifiable goods and prevent scalable harms. The economics of

growth and prosperity then dominate, and emphasis is placed on the tools that enable us to anticipate the changes that arise, so that adverse impact can be mitigated. The knowledge and tools for accomplishing these economic goals are the knowledge and tools of science itself. Ethics thus becomes a kind of science. By contrast, those from the humanities view ethics in terms drawn from the humanities. They tend to see the goods advanced and the harms diminished as complex creations, inseparable from the stories we choose to tell ourselves about who we are and what we wish to be. Ethics is concerned with the narratives of a meaningful life, with courage, integrity, and the wisdom of renunciation. It arises out of past traditions – cultural, religious, and philosophical – that orient us to a vision of life that is inseparable from how we, today, understand what makes our lives significant, what we value and want to sustain, and how we jointly, as a community, configure our practices. When the scientist looks at these forms of discourse, he or she tends to see fuzzy, reactionary, ambiguous tales told by a prescientific mind and when those from the humanities look at the scientist, they are suspect, never believing that the scientist really takes seriously the pressing ethical issues, that he or she sees things of ethical importance, or that he or she does anything more than rationalize the most rapid pursuit of the treasured research.

All this – the characterization of these “two cultures” – is of course not quite accurate but is a distorting oversimplification. There are many people from the sciences and from the humanities who are interested in engaging the ethical issues at a much deeper level, and with a serious consideration of all the relevant factors, but when the two cultures are split and debate polarized, each side characterizes the other in a negative way, failing to appreciate the concerns that are motivating the discussion. Different languages, traditions of critical reflection, and assumptions about the needed task all hinder genuine communication. The core task is to get beyond this, to frame ethics in a way that captures the wisdom in both cultures. Within the sciences we see emerging a form of understanding and capacity for intervention that can, should, and will inevitably guide what we become, but that is not enough. Ethics goes beyond the projection and analysis of the scientist – it is a question of what we want to make of ourselves, how we are going to exercise our freedom individually and collectively, and how we craft that good, which we call our own. There are wrong answers to this, ways of configuring our lives that are destructive and diminishing, but there is no single right answer. We need to resolve what we wish to be, to reflect upon and decide how we want to make ourselves and our world. Within the humanities are stories and modes of reflection that inform those decisions, those acts of will and freedom. By bridging the cultures, we integrate the diverse capacities – descriptive and prescriptive – and form patterns of self-regulation, which are themselves the sign of maturity.

There is an important difference between the way a child and an adult approach ethics. For children, ethical norms are external – impositions on wants and will. Rules prevent you from having candy, taking John’s toy, or playing instead of going to school. For the adult, “ethics” is not just about external rules and limits but is about the inner guidance for life. Through ethical reflection, adults develop the wisdom to craft, in a responsible way, their own future.

In the face of the ethical challenges associated with NBIC convergence, we need to enter maturity, developing that form of reflection that characterizes an adult. Only as adults should we enter the radically new world that opens up in front of us.

### **Appendix: Conceptual Orientation**

Technologies of communication such as writing, the printing press, and the computer have been the subject of extensive reflection, and they serve as a useful example of how technology alters both the form and content of social interaction and personal life (Gumbrecht and Pfeiffer, 1993). Nearly two and a half millennia ago Plato’s *Phaedrus* recounted the anxieties that attend the introduction of writing (e.g., how this technology disrupts the very character of self, and how it can mask the deep loss associated with such transformation). Technology is not just a means to some end. Through its social and material forms, technique takes on a life of its own and can radically alter the whole human condition, including our very capacity to assess it and rightly use it. Critics of technology rightly highlight the deep link between form and content. However, they also overstate the unity of form and content and thus transform this important insight into a kind of all-encompassing philosophical insight. Consider, for example, Neil Postman’s *Technopoly: The Surrender of Culture to Technology* (1992). After rightly showing how writing and other technologies like the mechanical clock create a new constellation of value and assessment, he rapidly moves to overstated claims about how the introduction of computers into education displaces more valuable content with the know-how associated with using these, or how computers will serve elites, but not the masses. Through these kinds of overstatement, an important insight is transformed into a kind of anti-technological ideology. A far more insightful, but still overstated, account is provided in the older, but far deeper, analysis of Jacques Ellul’s *The Technological Society* (1964). I seek to outline a middle way between two extremes. On one side, we have those like Postman or ETC Group, who too quickly equate form and content, and who see in integrative technologies a threat. On the other side, we have those who do not appreciate the form–content linkage, and who think that all technologies are basically neutral and that we can simply reflect in a *post hoc* way on good uses and bad uses.

The “trading zones” idea arose in anthropology, in which it was used to describe the cultures of exchange that emerge at the intersection of different communities. In a clever extension, Peter Galison used the idea of trading zones to account for the possibility of collaboration between scientists and engineers, who work with fundamentally different and even irreconcilable assumptions. Specifically, he considered 20th-century physics and explored the kinds of fluid linkages and conceptual frameworks that emerge at the intersection of theoretical, experimental, and instrument-oriented cultures. Within the larger “unity of science” debate, the “trading zones” concept is on the disunity of science side, and it provides an account of how deeply incommensurable cultures of science can nevertheless effectively collaborate on projects like the development of radar, superconducting supercolliders (Galison, 1997), and magnetic resonance imaging (Baird and Cohen, 1999). In another very interesting extension of the phrase, Mike Gorman (2003, 2004) now uses the “trading zones” idea to highlight a task that is integral to any major social or scientific endeavor; namely, the task of forming effective alliances that are integral to interdisciplinary scientific research. Gorman asks how the trading zones integral to NBIC convergence might be established. He thus takes a descriptive term used to understand the *ad hoc*, fluid adjustments of different research cultures, and he transforms it into an account of the patterns of overlap that might be consciously advanced in order to take a disconnected group of individuals and integrate them into an effective research alliance. Moreover, he uses this “disunity of science” concept to advance an account of the character of the scientific unity that might emerge in an NBIC initiative that is, perhaps, closely associated with the “unity of science” side of the debate. The “unity of science” thrust is, for example, clearly seen in Mike Roco’s confidence that scientific and engineering disciplines will be integrated on the basis of a material unity at the nanoscale; similarly, Bainbridge (2004) is confident that such a unity will be advanced by a richer account of the semantic logic integral to information systems. Here, in these diverse NBIC proposals, lies the possibility of genuine advancement in the long-standing “unity of science” debate. As a next step, it would be helpful to make more explicit the proposed trading zones concept and explore how this might be integrated with affirmations of a material unity at the nanoscale and with an account of semantic systems. In a previous NBIC essay, I proposed a three-dimensional systems schema that can provide the framework for working out this linkage (Khushf, 2004c), but the details of the difference-in-unity this makes possible must be put off for another time.

My thesis regarding how the rate of technological development transforms the very form of ethical reflection is, of course, not new; for example, it is integral to Ellul’s account of the technological society (1964). Postman’s (1993) distinction between tool-using cultures, technocracies, and

technopolies rests upon the pervasiveness of technological influence, with quantitative increase leading to a qualitative shift in culture. In these accounts, and in many others, the core concern is how human life is increasingly configured in terms of the set of techniques that, at first, were mere means to the realization of deeper human ends. The technological means become the end itself. However, my point is in a very significant sense different from these criticisms of technology. Although I share their interest in how the accelerating rate leads to a qualitative transition, I do not think this necessarily implies an overwhelming of human capacity and consequent dehumanization. By seeing how conventional modes of wisdom and ethical reflection are overwhelmed, we see the challenge and problem, and this can open avenues for self-transcendence and freedom that were not previously possible. This possibility of something genuinely new is absent in the criticisms – the critics see the challenge, and they see the limits of current capacity, but then they recoil, wanting some kind of conservative recovery. This simple conservatism is especially apparent in Postman (1993), Fukuyama (2002), and McKibben (2003). Ellul is far more profound, as he is in many ways more pessimistic about such recovery, but he also glimpses in a more genuine way the possibility of freedom and transcendence.

## References

- Arnall, A. H. 2003. *Future Technologies, Today's Choices: Nanotechnology, Artificial Intelligence and Robotics; A Technical, Political and Institutional Map of Emerging Technologies*. London: Greenpeace Environmental Trust.
- Bainbridge, W. S. 2004. The evolution of semantic systems. Pp. 150–177 in M. C. Roco and C. D. Montemagno (eds.), *The Coevolution of Human Potential and Converging Technologies*. New York: New York Academy of Sciences.
- Baird, D., and M. Cohen. 1999. Why trade? *Perspectives on Science* 7: 231–254.
- Eisenstein, E. 1980. *The Printing Press as an Agent of Change*. Cambridge: Cambridge University Press.
- Ellul, J. 1964. *The Technological Society*. New York: Vintage Books.
- ETC Group. 2003. *The Big Down: Genomes to Atoms*. Winnipeg, Canada: ETC Group.
- Evans, J. 2002. *Playing God? Human Genetic Engineering and the Rationalization of Public Bioethical Debate*. Chicago: University of Chicago Press.
- Fukuyama, F. 2002. *Our Posthuman Future: Consequences of the Biotechnology Revolution*. New York: Farrar, Straus and Giroux.
- Galison, P. L. 1997. *Image and Logic: A Material Culture for Microphysics*. Chicago: University of Chicago Press.
- Gingrich, N. 2003. Vision for the converging technologies. Pp. 36–55 in M. C. Roco and W. S. Bainbridge (eds.), *Converging Technologies for Improving Human Performance*. Dordrecht, Netherlands: Kluwer.
- Gorman, M. 2003. Combining the social and the nanotechnology: A model for converging technologies. Pp. 367–373 in M. C. Roco and W. S. Bainbridge



- (eds.), *Converging Technologies for Improving Human Performance*. Dordrecht, Netherlands: Kluwer.
- Gorman, M. 2004. Collaborating on convergent technologies: Education and practice. Pp. 25–37 in M. C. Roco and C. D. Montemagno (eds.), *The Coevolution of Human Potential and Converging Technologies*. New York: New York Academy of Sciences.
- Gumbrecht, H. U. and K. L. Pfeiffer (eds.). 1993. *Schrift*. Munich: Wilhelm Fink Verlag.
- Havelock, E. 1963. *A Preface to Plato*. Cambridge: Cambridge University Press.
- Havelock, E. 1986. *The Muse Learns to Write: Reflections on Orality and Literacy from Antiquity to the Present*. New Haven, Conn.: Yale University Press.
- Johnson, D. G. 2001. *Computer Ethics*. Upper Saddle River, N.J.: Prentice Hall.
- Joy, B. 2000. Why the future doesn't need us. *Wired* 8(4): 238–262.
- Kass, L. 1985. *Toward a More Natural Science: Biology and Human Affairs*. New York: Free Press.
- Kass, L. 2002. *Life, Liberty and the Defense of Dignity: The Challenge for Bioethics*. San Francisco: Encounter Books.
- Khushf, G. (ed.). 2004a. *Handbook of Bioethics: Taking Stock of the Field from a Philosophical Perspective*. Dordrecht, Netherlands: Kluwer.
- Khushf, G. 2004b. The ethics of nanotechnology: Vision and values for a new generation of science and engineering. Pp. 29–55 in *Emerging Technologies and Ethical Issues in Engineering*. Washington, D.C.: National Academies Press.
- Khushf, G. 2004c. Systems theory and the ethics of human enhancement: A framework for NBIC convergence. Pp. 124–149 in M. C. Roco and C. D. Montemagno (eds.), *The Coevolution of Human Potential and Converging Technologies*. New York: New York Academy of Sciences.
- Kurzweil, R. 1999. *The Age of Spiritual Machines*. New York: Penguin Books.
- Marcus, S. J. 2004. *Neuroethics: Mapping the Field*. New York: Dana Press.
- McKibben, B. 2003. *Enough: Staying Human in an Engineered Age*. New York: Times Books, New York.
- Ong, W. 1982. *Orality and Literacy*. London: Methuen.
- President's Council on Bioethics. 2003. *Beyond Therapy: Biotechnology and the Pursuit of Happiness*. [www.bioethics.gov/reports](http://www.bioethics.gov/reports).
- Parens, E. (ed.) 1998. *Enhancing Human Traits: Ethical and Social Implications*. Washington, D.C.: Georgetown University Press.
- Postman, N. 1993. *Technopoly: The Surrender of Culture to Technology*. New York: Vintage Books.
- Roco, M. C., and W. S. Bainbridge (eds.). 2001. *Societal Implications of Nanoscience and Nanotechnology*. Dordrecht, Netherlands: Kluwer.
- Roco, M. C., and W. S. Bainbridge (eds.). 2003. *Converging Technologies for Improving Human Performance*. Dordrecht, Netherlands: Kluwer.
- Roco, M. and Montemagno, C. (eds.). 2004. *The Coevolution of Human Potential and Converging Technologies*. New York: New York Academy of Sciences.
- Snow, C. P. 1959. *The Two Cultures and the Scientific Revolution*. New York: Cambridge University Press.

## 17. SCIENCE CONFRONTS THE LAW

*Sonia E. Miller, Attorney-at-Law*

*Abstract:* This chapter is a historic narrative about the law's difficulty and efforts in understanding what constitutes science and how best to assess its validity in the courts and its attempts to reconcile their differences.

### Introduction

In *Essay 37* of *The Federalist Papers*, James Madison wrote:

All new laws, though penned with the greatest technical skills and passed on the fullest and most mature deliberation, are considered as more or less obscure and equivocal, until their meaning be liquidated and ascertained by a series of particular discussions and adjudications. . . . The use of words is to express ideas . . . the definition of them may be rendered inaccurate by the inaccuracy of the terms in which it is delivered. . . . And this unavoidable inaccuracy must be greater or less, according to the complexity and novelty of the objects defined.

*The Federalist Papers* is considered to be one of the most significant political treatises in American legal scholarship. It assumes an honored place in American jurisprudence, third only to the Declaration of Independence and the Constitution of the United States of America (hereafter the Constitution).

Originally published in New York City newspapers between 27 October 1787 and 28 May 1788 under the pseudonym "Publius," the 85 essays were intended to clarify to, justify for, and persuade the people of New York to elect delegates who would ratify the proposed Constitution in the forthcoming state convention.

Today, *The Federalist Papers* is recognized as the most authoritative source for understanding the intent of the framers of the Constitution. Alexis de Tocqueville, in *Democracy in America*, considered to be one of the finest commentaries on American life, captured the significance of the court almost 150 years ago when he wrote: "I am unaware that any nation on the globe has hitherto organized a judicial power in the same manner as the Americans. . . . A more imposing judicial power was never constituted by any people." However, it is the interpretation of the intent of the framers that continues to challenge the legal profession to this day.

### Law in an Age of Change

Given the complexity and novelty of 21st-century on-demand societal pressures, coupled with the relentless advance of science and technology convergence integrated at the nanoscale, America's justice system remains "a product of the needs of the Industrial Era" (Katz, 1997). While groping to maintain its integrity, it operates within an inflexible, obsolete, and myopic framework.

Confronted by revolutionary change at an accelerating pace, today's justice system continues to be bound by historical precedence – a backward-looking reflection that stifles its vision and ability to progress to the Age of Convergence, which is an age driven by atoms, qubits, chips, neurons, and genes – drivers that are expected to impact medical diagnostics, therapy and health care delivery, energy, transportation, homeland security, business, education, space travel, and the traditional silos within which they thrive and perpetuate.

The justice system must be redeemed to meet the legal, ethical, societal, and economic demands of what has been touted as "the threshold of a new renaissance" (Roco and Bainbridge, 2003).

In *Essay 78 of The Federalist Papers*, Alexander Hamilton deliberates: "The interpretation of the laws is the proper and peculiar province of the courts. A constitution is, in fact, and must be regarded by the judges as, a fundamental law. It therefore belongs to them to ascertain its meaning as well as the meaning of any particular act proceeding from the legislative body. If there should happen to be an irreconcilable variance between the two, that which has the superior obligation and validity ought, of course, to be preferred; or, in other words, the Constitution ought to be preferred to the statute, the intention of the people to the intention of their agents . . . in determining between two contradictory laws. . . . The rule which has obtained in the courts for determining their relative validity is that the last in order of time shall be preferred to the first. . . . They thought it reasonable that between the interfering acts of an *equal* authority that which was the last indication of its will should have the preference . . . the prior act of a superior ought to be preferred to the subsequent act of an inferior and subordinate authority; and that accordingly, whenever a particular statute contravenes the Constitution, it will be the duty of the judicial tribunals to adhere to the latter and disregard the former. . . . It has been frequently remarked with great propriety that a voluminous code of laws is one of the inconveniences necessarily connected with the advantages of a free government."

Precedence, as defined in *Essay 78*, has resulted in a tome of laws and regulations across federal, statutory, and local jurisdictions, spanning a multitude of practice areas through which contemporary legal practitioners

must sift in order to zealously represent a client, corporation, government, non-government organization, or industry.

This begs the question. Are the legal and ethical issues anticipated to evolve from this “new renaissance” any different from associate risks of revolutions past? Can current legal precedence suffice to interpret the challenges that may appear before the courts? Is the current legal paradigm adequate to confront the unintended consequences that may be precipitated by the convergent integration of nanotechnology, biotechnology, information technology, and cognitive science (NBIC)? If scientific issues permeate the law, are the current tests promulgated for the admissibility of scientific evidence sufficiently sound to satisfy the standard of evidentiary reliability? As the imaginary character Ziggy is reputed to have said in 1981, “I spent my whole life preparing for a world that doesn’t seem to exist!”

The manner in which courts view scientific facts impacts their decisions, as well as their ability to separate and distinguish science from so-called junk science, pseudoscience, or “pathological science” – the science of things that are not so.

In March 2001, Iowa District Court Judge Timothy O’Grady ruled in *Harrington v. State*, Case No. PCCV 073247, Pattawattamie County, that brain fingerprinting was admissible in petitioner’s quest for a new trial. Because the proffered evidence, in this case, brain fingerprinting, was a novel forensic application of psychophysiological research methods, the court was required to determine whether this scientific evidence was sufficiently reliable to merit admission into evidence.

Brain fingerprinting exonerated an innocent man who spent 22 years in prison for a murder he allegedly did not commit. According to the O’Grady court’s interpretation of the admissibility of scientific evidence as imposed by *Daubert v. Merrell Dow Pharmaceuticals, Inc.*, 509 U.S. 579 (1993), brain fingerprinting proved that the defendant’s brain did not contain details of the crime that would be known to the perpetrator – that there was not a match between the information stored in the brain and the details of the crime.

Is brain fingerprinting science or pseudoscience, and was the O’Grady court able to aptly distinguish fact from hype? Can a supposed real-time psychophysiological subjective assessment of a subject’s response to stimuli in the form of words or pictures presented on a computer monitor, with electrical brain responses measured noninvasively through a patented headband equipped with sensors, be considered science?

This raises two questions. First of all, what is science? And second, what is scientific evidence?

For 70 years, until 1993, the federal courts defined the admissibility of scientific evidence in relation to *Frye v. United States*, 293 F. 1013, 1014 (D.C. Cir. 1923), considered to be a defendant-friendly standard. *Frye*

decreed that (1) trial judges are incompetent to determine the reliability of proffered scientific evidence, and therefore, that (2) the trial judge must determine not whether in his judgment the proffered scientific evidence constitutes good science but, rather, whether it is based on scientific methods and principles that have gained general acceptance in the relevant scientific community.

In 1972, the Federal Rules of Evidence, and in particular Rule 702, established the principle that expert opinion evidence was admissible if it would assist the trier of fact in understanding the evidence or in determining a fact in issue.

Pursuant to *Daubert v. Merrell Dow Pharmaceuticals, Inc.*, 509 U.S. 579, 590, 594 (1993) (construing Federal Rule of Evidence 702), the U.S. Supreme Court held that the standard of admissibility of novel scientific evidence is a showing of reliability based on whether

1. A theory or technique can be, and has been, tested
2. The theory or technique has been subjected to peer review and publication
3. With respect to a particular technique, there is a high known or potential rate of error, and whether there are standards controlling the technique's operation
4. The theory or technique enjoys general acceptance within a relevant scientific community.

Under *Daubert*, the U.S. Supreme Court established the trial judge as a gatekeeper with the responsibility of assessing whether the reasoning or scientific methodology could properly be applied to the facts at issue, claiming that the judge was sufficiently competent to evaluate scientific evidence without resorting to what is generally accepted in the scientific community. It defined science as a process for proposing and refining theoretical explanation about the world that is subject to further testing and refinement.

*General Electric Co. v. Joiner*, 552 U.S. 136, 143 (1997) held that conclusions and methodology were not entirely distinct from one another, and *Kumho Tire Co. v. Carmichael*, 526 U.S. 137 (1999) extended the rationale under *Daubert* to cases in which the proffered expert has engineering, technical, or other training not described as scientific.

As a result of *Daubert*, *Joiner*, and *Kumho*, Federal Rule 702 was amended to read: "If scientific, technical, or other specialized knowledge will assist the trier of fact to understand the evidence or to determine a fact at issue, a witness qualified as an expert by knowledge, skill, experience, training, or education, may testify in the form of an opinion or otherwise, if (1) the testimony is based upon sufficient facts or data; (2) the testimony is

the product of reliable principles and methods; and (3) the witness has applied the principles and methods reliably to the facts of the case.”

As technology and scientific knowledge have evolved at an ever-increasing pace, courts throughout the country have struggled with the formidable task of separating scientific fact from fiction and determining what constitutes scientific evidence. Justice Stephen Breyer has written that “science itself may be highly uncertain and controversial with respect to many of the matters that come before the courts. . . . Many difficult legal cases fall within this area of scientific uncertainty. . . . The more uncertain the law, the more litigation will take place” (Huber, 1991). Yet, as Justice Oliver Wendell Holmes once observed, “certitude is not the test of certainty. . . . The best test of certainty we have is good science – the science of publication, replication, and verification, the science of consensus and peer review” (Huber, 1991).

### **Conclusion**

Many people today might agree with the words Shakespeare wrote in 1591: “The first thing we do, let’s kill all the lawyers” (*King Henry VI*, Part II, Act IV, Scene ii). Scientists and engineers frequently complain that lawyers stifle innovation and hinder progress and the swift advance of scientific discovery. They are not the first group of professionals who have found fault with and directed satirical barbs against the legal profession. Lawyer jokes permeate society’s general perception of the usefulness of legal practitioners. Robert Frost, a well-respected poet, was once quoted as saying: “A jury consists of twelve persons chosen to decide who has the better lawyer.” Even lawyers and judges protest and write about the chaos and injustice within the justice system, frequently calling for its broad legal overhaul.

One reason for this dissatisfaction might be that “lawyers and scientists continue to see the world through very different lenses. Because neither discipline will or should have to adopt the other’s world views, they must reconcile their differences. In practice, however, scientists are very often frustrated and disgusted by their experience with the law. . . . Lawyers too are very often frustrated and disgusted by their experience with science . . . the role science plays in our daily lives will continue to increase exponentially. . . . In the end, in a constitutional democracy, the people are responsible for their government’s policy. In our technological society, this requires that they too understand how science informs that policy” (Faigman, 2000).

If there is to be change and understanding at the intersection of law and science, we, as a society, must take personal responsibility. “The concept of personal responsibility and truly foreseeable conduct has all but disappeared as case law moves from the ridiculous to the downright outrageous. . . .

Lawyers and judges are determining our social and economic future. . . . As our laws reflect much about our modern society, we must take a look at ourselves” (Crier, 2002).

## References

- Barabasi, A.-L. 2003. *Linked*. New York: Plume Books.
- Crier, C. 2002. *The Case Against Lawyers*. New York: Broadway Books.
- Davidson, L. S. 2004. *Ludicrous Laws & Mindless Misdemeanors: The Silliest Lawsuits and Unruliest Rulings of All Times*. Edison, N.J.: Castle Books.
- de Tocqueville, A. *Democracy in America*. Volume 1. 1835. Volume 2. 1840. [xroads.virginia.edu/~HYPER/DETOC/toc\\_indx.html](http://xroads.virginia.edu/~HYPER/DETOC/toc_indx.html).
- Faigman, D. L. 2004. *Laboratory of Justice: The Supreme Court's 200-Year Struggle to Integrate Science and the Law*. New York: Henry Holt and Company.
- Faigman, D. L. 2000. *Legal Alchemy: The Use and Misuse of Science in the Law*. New York: W.H. Freeman.
- Federal Judicial Center. 2000. *Reference Manual on Scientific Evidence, 2d Edition*. Washington, D.C.: Federal Judicial Center. [air.fjc.gov/public/home.nsf/pages/16](http://air.fjc.gov/public/home.nsf/pages/16).
- Foster, K. R., and D. E. Bernstein. 1999. *Phantom Risk: Scientific Inference and the Law*. Cambridge, Mass.: MIT Press.
- Foster, K. R., and P. W. Huber. 1999. *Judging Science: Scientific Knowledge and the Federal Courts*. Cambridge, Mass.: MIT Press.
- Hamilton, A., J. Madison, and J. Jay. 1788. *The Federalist Papers*. McLean Edition.
- Huber, P. W. 1991. *Galileo's Revenge: Junk Science in the Courtroom*. New York: HarperCollins.
- Huber, P. W. 1990. *Liability: The Legal Revolution and Its Consequences*. New York: Basic Books.
- Jasanoff, S. 1997. *Science at the Bar: Law, Science, and Technology in America*. Cambridge, Mass.: Harvard University Press.
- Joy, B. 2000. Why the future doesn't need us. *Wired Magazine* (April). [www.wired.com/wired/archive/8.04/joy\\_pr.html](http://www.wired.com/wired/archive/8.04/joy_pr.html).
- Katz, R. R. 1997. *Justice Matters: Rescuing the Legal System for the Twenty-first Century*. Seattle, Washington: Discovery Institute.
- Makeig, T. H. 2001. Admissibility of scientific evidence in Iowa's state and federal courts. *The Litigation Newsletter* (September).
- Miller, S. E. 2004a. The convergence of C: Legal issues emerge as cognitive science and IT become one. *New York Law Journal* 231(22, February 03). [www.ctba.us/articles/NYLJ.ConvergenceofC.doc](http://www.ctba.us/articles/NYLJ.ConvergenceofC.doc).
- Miller, S. E. 2004b. Science in the courtroom: Legal disputes increasingly involve biotechnology, genetics. *New York Law Journal* 231(104, June 1). [www.ctba.us/articles/NYLJ.ConvergenceofB.05-2004.doc](http://www.ctba.us/articles/NYLJ.ConvergenceofB.05-2004.doc).
- Roco, M. C., and W. S. Bainbridge. 2003. *Converging Technologies for Improving Human Performance*. Dordrecht, Netherlands: Kluwer.
- Susskind, R. 1996. *The Future of Law: Facing the Challenges of Information Technology*. New York: Oxford University Press.

## 18. HUMAN ENHANCEMENT AND THE EMERGENT TECHNOPOLITICS OF THE 21ST CENTURY

*James J. Hughes, Trinity College*

*Abstract:* The political terrain of the 20th century was shaped by the economic issues of taxation, labor, and social welfare and the cultural issues of race, nationalism, gender, and civil liberties. The political terrain of the 21st century will add a new dimension – technopolitics. At one end of the technopolitical spectrum are the technoconservatives, defending “human dignity” and the environment from technological progress. On the other end of the spectrum are the technoproggressives, holders of the Enlightenment faith that scientific and technological progress is liberating. Some of the key points of conflict in the emerging technopolitical struggle are the bioethical debates over human enhancement technologies. Technoproggressives such as “transhumanists” advocate for the right to use technologies that transcend human limitations, whereas technoconservatives argue for a strict limit on the nontherapeutic uses of biomedicine. Technopolitics has cut across the existing political lines and created odd coalitions between left-wing and right-wing technoconservatives on one side and technolibertarians and technodemocrats on the other. Future technopolitical debates are suggested that will force further technopolitical polarization.

### Introduction

In 2004, *Foreign Policy* magazine asked eight prominent intellectuals to identify the most dangerous ideas in the world. Robert Wright’s essay fingered the idea of a “war on evil,” while Marxist historian Eric Hobsbawm attacked attempts to “spread democracy.” Philosopher Martha Nussbaum zeroed in on “religious intolerance,” and Paul Davies discussed the erosion of the idea of free will. Francis Fukuyama’s answer (Fukuyama, 2004) was the most intriguing, as his most famous work, *The End of History and the Last Man*, written after the collapse of the Soviet Union, argued that there were no longer dangerous ideologies that could threaten the Pax Americana of democratic capitalism. However, Fukuyama has changed his mind on that score. His new bête noir was one most of the readers of *Foreign Policy* had never heard of: “transhumanism.”

Fukuyama’s definition of transhumanism is the movement that seeks “to liberate the human race from its biological constraints” – and that is pretty close to the way transhumanists define their movement as well. That is, the few tens of thousands of them who actually use the term and who characterize their opponents like Fukuyama as “bioconservatives.” Given the miniscule size and invisibility of the transhumanist movement, why did



Fukuyama believe that movement posed a more serious threat than, say, Islamic fundamentalism? Because “the fundamental tenet of transhumanism – that we will someday use biotechnology to make ourselves stronger, smarter, less prone to violence, and longer-lived . . . is implicit in much of the research agenda of contemporary biomedicine.” Indeed, the use of converging technologies to improve human performance is the explicit goal of the NBIC conferences, whose participants are often influential leaders in government, industry, and academia. For Fukuyama and a growing number of technoconservative critics, the irresistible human enhancement possibilities emerging from the convergence of NBIC threaten new conflicts between the unenhanced and enhanced and threaten to upset the present rough equality among human beings.

Fukuyama articulated this argument at greater length in his 2002 book *Our Posthuman Future* (Fukuyama, 2002), which argued for broad restrictions on the use of biotechnology that might cross the barrier from “therapy” to “enhancement,” from Ritalin to genetic engineering. He is also a member of the U.S. President’s Council on Bioethics, which, under the leadership of Chairman Leon Kass, produced the enormous critique of human enhancement medicine *Beyond Therapy* (President’s Council on Bioethics, 2003).

In several decades, I think it will be clear that these events marked a turning point – the first explicit shots fired in the technopolitics of the 21st century. These coming technopolitical conflicts will be fought over the development, regulation, and accessibility of human enhancement technologies and will bring to the table fundamentally different conceptions of citizenship, rights, and the polity. Technopolitics will be as profound as the struggles between socialists and free marketers, or secularists and fundamentalists, will mix and blur among the 21st-century heirs of those battles. Unlike the struggle over trade union rights or gay marriage, however, the outcome of the technopolitical struggles will determine whether the human race itself will have a future.

In this essay I outline the new technopolitical axes of the 21st century – axes historically rooted in environmentalism and bioethics but now extending to other fields because of the convergence of technologies. I discuss some of the key figures and organizations that have shaped the current debate in the United States, from academic bioethics and the anti-abortion movement to the political left and environmental movements. Then I suggest some of the policy debates likely to further crystallize and mobilize these ideological camps.

### **Bioethics as Proto-Technopolitics**

Many political ideas begin as parlor room debates or philosophical treatises long before they motivate parties and revolutions. Other debates among intellectuals stay in the parlor, influential among some policy-making elites but never embodied in social and political movements. When bioethics first emerged out of philosophical and theological debates in the 1960s, it was not yet clear that its issues would ever divide the public.

Then in 1979 President Carter appointed a President's Commission for the Study of Ethical Problems in Medicine and Biomedical and Behavioral Research. This first presidential bioethics commission worked from January 1980 to March 1983, and its dozen products contributed to fundamental changes in medical practice and policy, from organ transplantation and the declaration of death to the regulation of genetic engineering and research on human subjects. Quickly the new anti-abortion movement realized the connection of bioethics to its campaign to defend "the sanctity of life," and federal bioethics advisory bodies were embroiled in the struggle between the anti-abortion lobby and the largely pro-choice academics involved in bioethics. Unlike the debates over brain death or the withdrawal of life support, members of the lay public have had strong opinions about the legal personhood of the fetus and whether women's rights to control their own bodies extend to a control their own bodies extend to a right to terminate pregnancy. After barely two decades of parlor-room collegiality, bioethics had begun to become technopolitics, and bioethical theories had begun to reveal themselves as political ideologies.

Although theologians had been important in bioethics in the 1960s and 1970s, by the 1980s most academic bioethicists were secular and leaned toward liberal democratic ethical principles. One popular approach to bioethics, for instance, has been the "principlism" articulated by Beauchamp and Childress (1994) – autonomy, justice, and beneficence/nonmaleficence – direct corollaries of the French revolutionary slogans of liberty, equality, and solidarity. Theological arguments that we should treat Man as *imago dei* gave way to modern liberal democratic and utilitarian arguments: the world will be a better place, and medical care will provide optimal benefit, if we give people equal resources, allow them to make decisions for themselves, and only make decisions for them when they cannot. But the exclusion of religious rationales from bioethical debate did not mean that bioethicists were now agents of pure reason and liberty.

In the 1970s, the focus of most bioethicists' attention had been on protecting patients from unethical scientific research and overly aggressive applications of end-of-life care, protecting the public from science and technology rather than securing their rights to it. Bioethicists also began to raise questions about the dangers of cloning, *in vitro* fertilization, and genetic engineering. There were occasional provocateurs like Joseph Fletcher, who

argued that humans have a right and obligation to control their own genetics (Fletcher, 1974), but as bioethics matured, it became clear that the biomedical industry did not need much help in pointing out the advantages of new drugs and biotechnology. The public and media turned to bioethicists for the cautions, caveats, and anxious hypotheticals about the future. Bioethicists responded to positive reinforcement and developed a finely honed suspicion of medical advances and a repertoire of “questions” that all technologies should be subjected to by bioethicists before being approved.

Today many bioethicists, informed by and contributing to the growing anti-technology orientation in the social sciences and humanities, start from the assumption that new biotechnologies are being developed in unethical ways by a profit-driven medical-industrial complex and will have myriad unpleasant consequences for society, especially for women, the poor, and the powerless. Rather than emphasizing the liberty and autonomy of individuals who may want to adopt new technologies or arguing for more equitable access to new biotechnologies, bioethicists often see it as their responsibility to slow the adoption of biotechnology altogether. The pervasive suspicion of technology and “progress” among bioethicists opened the field to crypto-religious doctrines of the importance of “human dignity,” instinctive moral sentiments, and respect for the natural order that provided a bridge language to the concerns of the religious conservatives.

The appointment of Leon Kass as the chair of President’s Council on Bioethics (PCB) in 2001 finally brought to a head this brewing contradiction within bioethics between the secular, liberal democratic tradition and the crypto-religious hostility to modernity that Kass embodied throughout his career. For the last 35 years, Leon Kass has been one of the chief conservative philosophical opponents of interventions into human reproduction and other medical technologies, from *in vitro* fertilization to withdrawal of life support. Kass is best known as a defender of the “wisdom of repugnance” or “yuck factor” – “repugnance is the emotional expression of deep wisdom, beyond reason’s power fully to articulate it” (Kass, 1997: 86).

Although he is Jewish and draws mostly from a Platonic and Aristotelian perspective, Kass’s appointment was warmly welcomed by the Christian right, who viewed him as an ally against abortion and secular bioethics. Kass, in turn, filled the President’s Council on Bioethics with conservative bioethicists, such as Mary Ann Glendon and Gilbert Meilander, and conservative intellectuals with little or no connection to academic bioethics, such as Robert George, Francis Fukuyama, James Q. Wilson, and Charles Krauthammer. The executive director for the PCB was Dean Clancy, a former aide to Texan Republican leader Dick Armey. The new PCB developed a symbiotic relationship with the conservative religious think-tank the Ethics and Public Policy Center and its journal of conservative bioethics,

*The New Atlantis*. The first product of the PCB under Kass was the recommendation that embryo cloning in research be criminalized – a reversal of the advice offered by the more liberal bioethics commission that served President Clinton. Kass's PCB then focused on human enhancement, encompassing psychopharmaceuticals to life extension, resulting in the mammoth report *Beyond Therapy* (President's Council on Bioethics, 2003). Reprising the themes already worked by Fukuyama and Kass, *Beyond Therapy* suggested that society should try to draw a line between therapy and enhancement (a line the PCB acknowledges is impossible to draw) or else see the erosion of our quality of life under the onslaught of ageless bodies, cheerful minds, and designed children.

One might mark the first salvo of mainstream bioethicists' resistance to Kassism as the 2003 essay "Leon the Professional." Written by editor Glenn McGee to preface an issue of the *American Journal of Bioethics*, an issue devoted to the ethics of human–animal chimeras, "Leon the Professional" hits the central tenet of Kassist technoconservatism:

[I]f we get past the "yuck" . . . [we] find that engineering of humans is not only ubiquitous and a function of ordinary human life as well as high-technology science, but also that the rules for avoiding "yuck" are a mere matter of faith themselves in the articles of a flimsy new kind of neoconservative natural law theory. And perhaps we are better off yucky but complicated than in the clean, well-lit spaces of the illusory safety of a "nature" that doesn't really exist. (McGee, 2003)

Left-wing bioethicists began a vocal campaign disparaging the focus of the PCB on posthumanity when 45 million Americans lacked health insurance, and billions around the world lack access to rudimentary medicine (e.g., Turner, 2004). When two of the few liberal members of the PCB were replaced with religious conservatives in the spring of 2004, American bioethicists erupted. A petition signed by hundreds of bioethicists protested the stacking of the PCB, and protests were organized against Kass's keynote address at the October 2004 meeting of the American Society of Bioethics and Humanities. In the midst of a presidential campaign in which support for embryonic stem cell research had become a surprisingly important wedge issue, bioethics was being reborn as technopolitics.

### **Jeremy Rifkin and Odd Bedfellows**

Future-oriented activists from all corners of the political landscape already have been building technopolitics for two decades. Although Kass and the Christian right make up the most influential segment of the emerging

technoconservative bloc, they have increasingly been joined by people from the left. The principal far-sighted strategist who has brought the left flank of technoconservatism into alignment with the Right is the veteran activist and writer Jeremy Rifkin.

In the 1960s and 1970s, Rifkin was an antiwar organizer and socialist activist, but in the late 1970s, Rifkin had a vision that the terrain of future politics would be fundamentally transformed by biotechnology in the same way that steam power and electricity had created new political and economic orders. In 1977 Rifkin went on to start the Foundation on Economic Trends to throw roadblocks in the way of biotech. Rifkin named his nemesis algeny, “the improvement of existing organisms and the design of wholly new ones with the intent of perfecting their performance.” However, for Rifkin (1993, 1998), algeny was also “a way of thinking about nature, and it is this new way of thinking that sets the course for the next great epoch in history.”

Rifkin quickly discovered the importance of alliances with the religious right built on their shared critiques of algenic hubris. In one campaign, Rifkin organized disgruntled former surrogate mothers and took them around the United States to pass laws banning surrogacy contracts. Rifkin used that campaign to build ties between Catholic conservatives who supported the Papal ban on surrogacy and feminists uneasy with “uteruses for hire.”

One of the issues that Rifkin sees as a clear and present danger is the crossing of species barriers using recombinant genetic engineering, a point that resonates with Christians concerned about humans “playing God.” So Rifkin reached out to religious groups arguing that these recombinant techniques not only were dangerous capitalist imperialism but also violate God’s plan for his separately created species, robbing life of its “sacredness.” In 1995 Rifkin announced that religious leaders representing more than 80 different religious groups had signed his “Joint Appeal Against Human and Animal Patenting” which read “We believe that humans and animals are creations of God, not humans, and as such should not be patented as human inventions.”

Again, in 2001, a heated battle raged between a broad coalition defending medical researchers’ use of cloned embryos to generate stem cells and the right-to-life movement and Republican president, who favored a ban on federally funded research using embryonic stem cells. In the midst of this battle, Rifkin sent out a petition to support a ban on “cloning” to prominent left-wingers and feminists. His petition had neo-conservatives William Kristol and Francis Fukuyama as cosignatories, and Rifkin said he wanted to unite the social conservative and liberal left camps around a shared opposition to “cloning” and the “commodification” of life it represented. “We are also concerned about the increasing bio-industrialization of life by the scientific community and life science companies and shocked and dismayed that clonal human embryos have been patented and declared to be

human ‘inventions.’ We oppose efforts to reduce human life and its various parts and processes to the status of mere research tools, manufactured products, commodities and utilities.”

Rifkin is quite clear about the importance of his odd coalitions to the coming “fusion technopolitics.” In a 2001 article titled “Odd Coupling of Political Bedfellows Takes Shape in the New Biotech Era” Rifkin (2001) says “The Biotech Era will bring with it a different constellation of political visions and social forces, just as the Industrial Age did. The current debate over embryo and stem cell research already is loosening the old political allegiances and categories. It is just the beginning of the new politics of biology.” Rifkin is right about the new technopolitics, and his successes build on the commonalities of technoconservatism on the left and right, but the technoproggressives are building some odd coalitions as well.

### **Mapping Technopolitics**

In the last century you could pretty accurately place someone politically by where he or she stood on two basic sets of political issues: economics and culture. Economic conservatives are not interested in reducing inequality and do not care for the welfare state, trade unions, taxation, business regulation, and economic redistribution. Economic progressives want people to be more equal and generally favor all these government measures. Cultural conservatives are generally nationalistic, ethnocentric, religiously conservative, and skeptical of women’s equality, sexual freedom, and civil liberties. Cultural progressives are generally secular and cosmopolitan and are supporters of civil liberties and minority and sexual rights. Figure 1 maps this political territory.

Where people and parties fall out on each of these two axes predicts their positions on other issues on that axis but not how they feel about issues on the other axis. The issues within each axis have some ideological and practical consistency that holds them together. People who are tolerant of changing gender roles and women’s rights are also more open to changing sexual mores such as gay rights, and opponents of social welfare are more likely to support lower taxes. However, knowing how people feel about women wearing pants does not tell you how they feel about right-to-work laws.

The terrain that these two axes create, shown in Figure 1, allows us to map out how parties and alliances in Western democracies form and shift. The economic interests of White working-class people have generally led them toward the upper half of the box – economic progressivism – whereas their educational backgrounds have made them more culturally conservative, leaning them toward the left hand side of the box. So, the natural politics of the native working class is the culturally conservative populism of Huey

Long or Pat Buchanan in the United States, the far right parties of Europe, or a Juan Peron of Argentina. Trade unions and social democratic parties, however, have generally been led by well-educated cosmopolitans who are trying to build alliances with the culturally liberal middle classes, pulling together working-class and middle-class support for the upper-right-hand “social democratic” corner. When working people stop believing their economic interests are represented by the social democrats, their distaste for immigration, gay rights, affirmative action, and abortion allows them to be pulled back toward the religious right in the lower-left-hand corner, anchored in the United States by the conservative churches that workers and the poor often attend.

**Figure 1. The Political Terrain of the 20th Century**

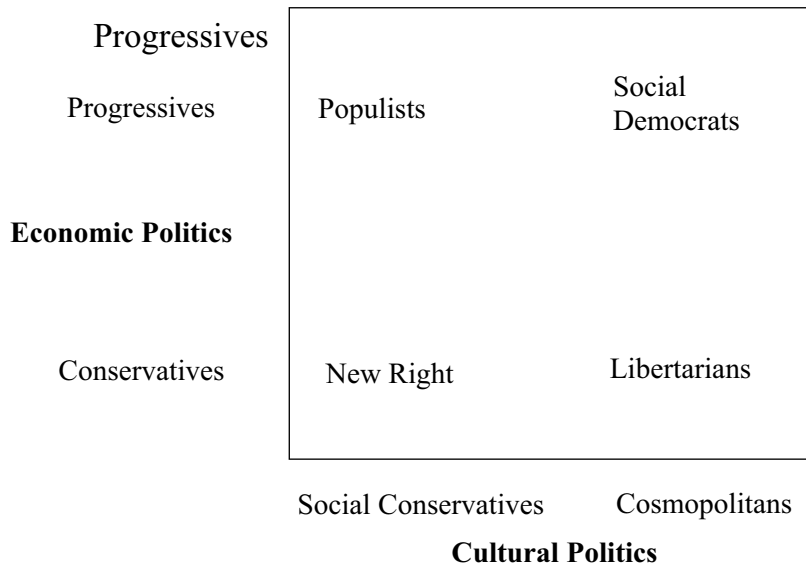

Gender is also tied to political leanings, with men tending toward cultural and economic conservatism. Economically, men tend to favor the cowboy individualism of the free market, and women are more supportive of the nurturing welfare state. Culturally, men are less supportive of women’s rights and sexual diversity, so men tend toward the New Right corner, and women toward the social democrats.

What is really interesting and new about 21st-century technopolitics, as illustrated in Figure 2, is that this third technopolitical dimension sticks straight out of the two-dimensional map. For instance, data from the 2002 EuroBarometer study reveal that support for biotechnology was not correlated with political opinions on redistribution or cultural conservatism

(Gaskell *et al.*, 2003). Instead, the strongest predictors of biotech views were “materialist values, optimism about technology, [and] confidence in actors involved in biotechnology and engagement” with biotechnological progress. People can be found in all political parties with the technoprogressive cluster of values as well as the technoconservative cluster. This gives rise to Rifkin’s odd left-right coalitions.

**Figure 2. The Political Space and Ideological Positions of the 21st Century**

(A = Technodemocrats; B = Technolibertarians; C = Left technoconservatives; D = Right technoconservatives)

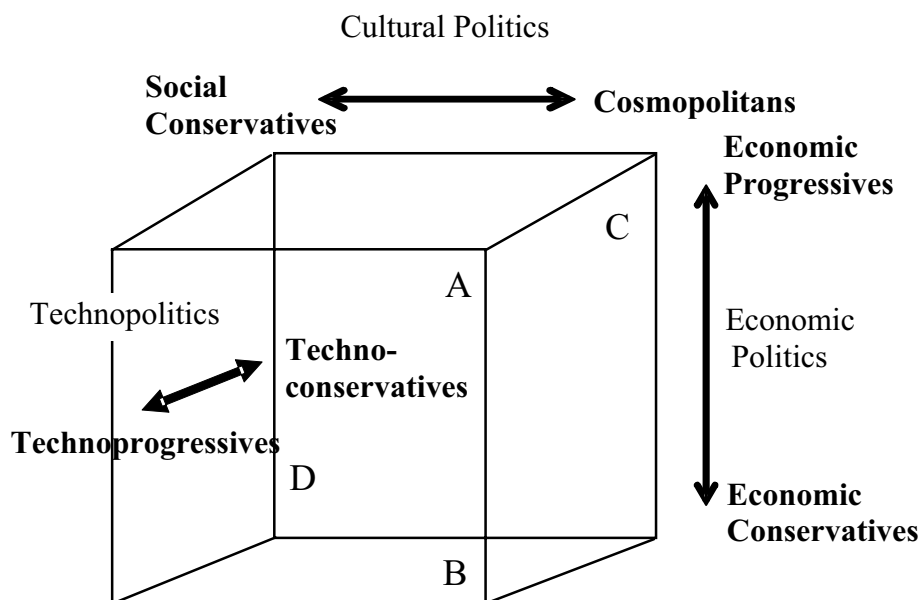

As technopolitics crystallizes out of issues and political struggles from the treatment of the comatose and stem cells to GM food and cloning – and out of newer issues associated with nanotechnology and the other convergent fields – activists, parties, and ordinary citizens are nudged towards technopolitical consistency. However, there are already constituencies that lean toward one end or the other of the technopolitical spectrum.

A large 2000 National Science Foundation (NSF) survey of American attitudes toward science and technology asked whether the benefits of genetic engineering would outweigh its dangers (NSF, 2000). Four out of 10 Americans thought genetic engineering’s benefits would outweigh the costs, whereas 28% thought the benefits and costs would be balanced, and 32% believed costs will outweigh benefits. In another national survey of Americans in 2000, conducted by the Public Policy Research Institute at



Texas A&M University, 53% said that genetic engineering would “improve our way of life in the next 20 years,” and 30% said it would not (Priest, 2000). In these and other surveys, the majority of American respondents have been in favor of the public having access to *in vitro* fertilization, therapeutic genetic therapy, and genetic screening and abortion for disabled fetuses. Still only a minority are in favor of the “enhancement” technologies. About a quarter of Americans favor genetic enhancement and “designer babies,” and about 1 in 10 favors legal reproductive cloning.

On the other end, hard-core technoconservatives appear to make up about a quarter to a third of the population. About a third of Americans consistently oppose embryonic stem cell research, for instance. In a 2002 survey of Americans conducted by the Genetics and Public Policy Center [GPPC] at Johns Hopkins University, a quarter to a half of those people polled were opposed to prenatal selection and *in vitro* fertilization (GPPC, 2002). Thus, depending on the issue, 10% to a majority might end up with the technoproggressives, and 25% to a majority might end up with the technoconservatives.

The dynamics of the technopolitical split also vary around the world. Europeans, still spooked by Nazi eugenics and mad cow disease, and with strong Green lobbies, are more negative towards all reproductive technology and genetic engineering, although they have become more technoproggressive in recent years (Gaskell *et al.*, 2002). Asians, however, are generally more positive than Americans towards these technologies. In a 1993 survey, a majority of Indians and Thais supported genetic enhancement for physical characteristics and intelligence, and even for making people more ethical (Macer, 1994).

Generational change, and rising educational levels and secularism worldwide, appear to be on the technoproggressive’s side, as technoproggressivism is more common among the young, the college educated, and the secular. Technoconservatism is more common among older people, the less educated, the more religious, and women. In the 2000 NSF survey, men believed genetic engineering’s benefits would outweigh costs 11% more often than women did (45% to 34%), and college graduates were more optimistic than those with high school degrees by 11% (48% to 37%). A 2001 Gallup poll on animal cloning found that 56% of those with postgraduate education said animal cloning should be allowed, compared to only 19% of those with a high school degree (Carroll, 2001). Women were much more likely to oppose animal cloning than men (74% of women to 53% of men opposed).

## Gathering of Forces

There are already technopolitical organizations gathering money, activists, and popular support into their four or five ideological camps. The technopolitics being staked out today in the United States include technoconservatism of the left and right, as well as “technolibertarians” and “technodemocrats.”

### *Right Technoconservatives*

The backbone of contemporary technoconservatism is the religious right, fired by the idea of divine boundaries on human ambition and hostility to abortion, euthanasia and changing sexual mores and gender roles. Belief in embryonic rights and the need for sacred limits on biomedical hubris are points of unity for Catholic and Protestant conservatives opposing *in vitro* fertilization, cloning, and genetic engineering. Catholic teaching also forbids “artificial” interference in the human procreation or any conception outside of marital sex, ruling out *in vitro* fertilization, surrogate motherhood, cloning, and genetic manipulation of embryos.

One of the bases for religious technoconservatism in the United States is the San Francisco–based Center for Bioethics and Culture (CBC). Funded by influential Christian right leader Chuck Colson, and directed by Nigel Cameron, the CBC has quickly grown to have branches in Chicago, Los Angeles, St. Louis, Tennessee, Wisconsin, and Washington, D.C. In its first 2 years the CBC’s principal activity has been sponsoring conferences on the threat to religious values from “TechnoSapiens;” that is, the transhumanist movement and human enhancement technologies.

The religious right correctly sees transhumanism as the latest manifestation of secular humanism – the claim that human beings can use reason to control and improve their lives without faith or divine intervention. Human reproductive and enhancement technologies are seen as violating the prohibition on hubris. Conservative Catholic and Protestant spokespeople are quite clear that genetic engineering of human beings and other efforts at “unnatural” longevity and human enhancement are attempts to usurp God’s powers. In 2002 Pope John Paul II said, for instance, that modern man “claims for himself the creator’s right to interfere in the mystery of human life. He wishes to determine human life through genetic manipulation and establish the limit of death.”

Against the demand for humanist self-determination, the Christian right has carefully honed the terms “human” and “human dignity” as stand-ins for less politically salable theological concepts. For instance, the “Manifesto on Biotechnology and Human Dignity” (CBC, 2002), organized by Cameron and Colson and signed by leading lights of the American right, says

“biotechnology . . . poses in the sharpest form the question: What does it mean to be human? . . . [I]n biotechnology we meet the moral challenge of the twenty-first century.” Biotechnologies threaten human dignity, says the manifesto, because they will lead to eugenics, mass farming of embryos for body parts, and the commodification of life. Most centrally, however, biotechnologies threaten the idea that humans, and only humans, have “dignity” from conception to death:

[T]he uniqueness of human nature is at stake. Human dignity is indivisible: the aged, the sick, the very young, those with genetic diseases – every human being is possessed of an equal dignity; any threat to the dignity of one is a threat to us all... humans are distinct from all other species; at every stage of life and in every condition of dependency they are intrinsically valuable and deserving of full moral respect.<sup>1</sup>

Up the coast in Seattle sits The Discovery Institute, another Christian right think-tank and the sponsor of technoconservative writer Wesley J. Smith. Smith was once a collaborator of left-wing consumer activist Ralph Nader and coauthor of a number of Nader’s books. Then a family friend with a terminal illness turned to the Hemlock Society for assistance in committing suicide. Smith was horrified at the supposed acceptance and complacency of bioethicists to America’s “culture of death,” and he started his odyssey to become a favorite writer and speaker for the Christian right.

Smith sees three interrelated threads in the culture of death: animal rights, personhood ethics, and transhumanism. In a 2002 article “The Transhumanists” in the Web version of *The National Review* (Smith, 2002), Smith warns: “Once we’ve been knocked off our pedestal of moral superiority [to animals] . . . society will accept measuring a biological ‘platform’s’ . . . moral worth by determining its level of consciousness. Thus, post-humans, humans, animals genetically engineered for intelligence, natural fauna, and even machines, would all be measured by the same standards.” For Smith, personhood-based citizenship will lead inevitably to a dictatorship of the posthumans. “Transhumanism envisions a stratified society presided over by genetically improved ‘post-human’ elites. Obviously, in such a society, ordinary humans wouldn’t be regarded as the equals of those produced through genetic manipulation.”

The religious right has eagerly embraced Smith’s conspiracy theory of animal rights activists, bioethicists, and transhumanists trying to enslave humanity. The CBC’s TechnoSapiens conference used a version of Smith’s “The Transhumanists” as its motivating document, and its themes found their

---

<sup>1</sup> [www.thecbc.org/redesigned/manifesto.php](http://www.thecbc.org/redesigned/manifesto.php)

way into routine attacks on transhumanists in the Christian media (e.g., Hook, 2004).

In the Midwest, the base for Christian right bioethics is Chicago's Center for Bioethics and Human Dignity (CBHD), led by John Kilner, chair of ethics at Trinity International University. In 2003 Kilner and his CBHD colleague C. Ben Mitchell published "Remaking Humans: The New Utopians Versus a Truly Human Future" (Mitchell and Kilner, 2003). In addition to the charge that transhumanists hate humanity and are dangerous totalitarians in disguise, Kilner and Mitchell make clear another, specifically Christian, objection. "Much of what the Transhumanists long for is already available to Christians: eternal life and freedom from pain, suffering, and the burden of a frail body. As usual, however, the Transhumanists – like all of us in our failed attempts to save ourselves – trust in their own power rather than God's provision for a truly human future with him."<sup>1</sup> Human enhancement is a distraction from the Christian promises of salvation in the afterlife.

In Washington, D.C., a locus of religious conservative bioethics is the Ethics and Public Policy Center, dedicated to reinforcing "the bond between the Judeo-Christian moral tradition and the public debate over domestic and foreign policy issues."<sup>2</sup> EPPC's BAD (Biotechnology and American Democracy) Project is headed by Eric Cohen, who works for Kass's PCB as a Senior Research Analyst. BAD's journal, *The New Atlantis*, publishes conservative commentaries on the potential of artificial intelligence, nanotechnology, biotechnology, reproductive technology, and life extension to erode "human dignity."

An example of BAD's technology politics was the enthusiastic participation of *The New Atlantis* in the Foresight Institute's October 2004 conference on nanotechnology policy in Washington, D.C. The Foresight Institute, a center of thinking about nanorobotics and molecular manufacturing since the 1980s, was regrouping after the institute felt that its perspective on nanorobotics was not given sufficient priority under the National Nanotechnology Initiative. *The New Atlantis'* managing editor, Adam Keiper, had previously written about nanotechnology (Keiper, 2003), arguing that technoconservatives needed to join the "nanotechnology revolution" in order to steer nanotechnologists away from hubristic radical redesigns of the human body. The Foresight meeting provided a perfect opportunity for such engagement. Keiper had *The New Atlantis* cosponsor the meeting of dejected nanotechnology visionaries and established a blog on the conference. He was awarded a place on the agenda for an eagerly anticipated address on "The Importance of Nanotech Politics." Keiper exhorted the audience that if they wanted to stop "getting their asses whipped" in funding turf wars they had to improve their image by severing their ties with

---

<sup>1</sup> [www.cbhd.org/resources/bioethics/mitchell\\_kilner\\_2003-08-29.htm](http://www.cbhd.org/resources/bioethics/mitchell_kilner_2003-08-29.htm)

<sup>2</sup> [www.eppc.org/](http://www.eppc.org/)

transhumanists. In his opinion, it would be disastrous for nanotechnology if its fortunes became tied to the looming struggle between transhumanists and technoconservatives that Keiper predicted would dominate Washington politics in the coming decades.

### *Left Technoconservatives*

Left-wing technoconservatives come in two basic flavors: New Left and deep ecologist. What unites these two approaches is their rejection of the traditional left narrative that equates scientific and technological with social progress.

For the New Left, the progress narrative ended with the rise of the military–industrial complex and corporate capitalism, which they saw as systematically designing and marketing technologies that reinforce White, male American corporate and military power. In reaction, the New Left embraced anti-technological pastoralism, voluntary simplicity, and “appropriate technology.”

One of the most sophisticated of the left technoconservative theorists is writer Langdon Winner. In his classic *The Whale and the Reactor: A Search for Limits in an Age of High Technology* Winner makes a careful argument that “artifacts have politics” – that the power relations of society are designed into technologies. According to Winner, modern technology, selected for and designed under the thumb of corporations and the military, encourages centralization, hierarchy, and the concentration of power. Some technologies are more likely to reinforce hierarchy and domination than others, and the goal of a democratic technology politics is to identify and encourage empowering technologies.

When it comes to nanotechnology and human enhancement technologies, however, Winner sees few opportunities for citizen empowerment, and much more for social control and hierarchy. In April 2003, Winner testified before the House Science Committee, along with transhumanist and computer scientist Ray Kurzweil and nanotechnologist Chris Peterson, on the advisability of the National Nanotechnology Initiative. That day, Winner became the first person to warn the U.S. Congress of the threat from posthumanity. In response to a question about when there would be greater-than-human intelligence, Winner sternly intoned “I hope never. One of the concerns about nanotechnology and science and engineering on this scale is that it is plowing onward to create a successor species to the human being. I think when word gets out about this to the general public they will be profoundly distressed. And why should public money be spent to create an eventual race of posthumans?” To which transhumanist Ray Kurzweil responded, “I would define the human species as that species that inherently

seeks to extend our own horizons. We didn't stay on the ground, we didn't stay on the planet, we're not staying with the limitations of our biology."

The Oakland-based Center for Genetics and Society, a leftist group opposed to "technoeugenics," argues that human enhancement technologies will lead to a genetic caste system. The CGS helped organize the September 2001 conference that launched bioethicists George Annas (2000, 2001) and Lori Andrews's campaign for an international treaty to ban cloning and inheritable genetic modification. The CGS staff lobby the UN in support of the ban and write op-eds for the media attacking transhumanists and advocates of germinal choice.

Some feminists are also now joining forces with the religious and environmental bioLuddites to oppose reproductive technology, cloning, and germinal choice. Feminist authors Naomi Klein and Judith Levine, women's health activist Judy Norsigian, and other prominent feminists have joined the Rifkin-organized progressive bloc in opposition to the use of embryos in medical research, even though it meant joining forces with the right-to-life movement. Norsigian says that women cannot ever give informed consent to genetic therapies because those risks cannot be fully known. Marcy Darnovsky of the Center for Genetics and Society notes the ironic difficulty of feminists arguing for restrictions on reproductive rights: "It will take focused effort to make it clear that altering the genes of one's children is not among the reproductive rights for which so many women and women's organizations have struggled" (Darnovsky, 2000).

Deep ecologists, in contrast, reject the progress narrative in a more fundamental way than the New Leftists. Deep ecology was first articulated by the philosophers Arne Naess and George Sessions in the 1970s (Naess, 1989; Sessions, 1995) and spread with the growth of the radical environmentalist groups like Earth First! The core of the Deep Ecology platform is the assertion that "The well-being and flourishing of human and nonhuman life on Earth have value in themselves. These values are independent of the usefulness of the nonhuman world for human purposes" (Naess and Sessions, 1993). Consequently, "Humans have no right to reduce this richness and diversity except to satisfy vital needs." In order to reduce humanity's excessive interference with the nonhuman world there must be "a substantial decrease of the human population."

The influence of deep ecology is increasingly pervasive throughout the liberal left and is found now in the writing of some of the most prominent leaders of the anti-human enhancement groups. One such deep ecologist is Andrew Kimbrell, the former policy director for Jeremy Rifkin, who went off to found the Washington lobby the International Center for Technology Assessment. Most of Kimbrell's energies have been devoted to attacking genetically engineered crops, but he has taken time out to write *The Human*

*Body Shop* (1993), an attack on the alleged commodification of organs and tissues that he sees as “desacralizing” the human body.

The radical environmental group Rural Advancement Foundation International changed its name in 2001 to the Action Group on Erosion Technology and Concentration (ETC), with a new mandate of fighting nanotechnology and genetic engineering. They have called for a global moratorium on nanotechnology research (2003a) and human enhancement technologies (2003b) on the basis of safety and equity concerns, as well as on the “precautionary principle.” The “precautionary principle” as used by ETC and the environmental movement is the assertion that no technology should be used until its risks are fully assessed. Because the long-term risks of technologies can never be fully assessed, the precautionary principle becomes a rationale for pervasive technoconservatism.

Mainstream environmental groups are also beginning to line up with the opponents of human enhancement technologies as they adopt a consistent technoconservatism. Carl Pope, the director of the Sierra Club, used his address to the 2001 meeting of the National Abortion and Reproductive Rights Action League to urge the gathered pro-choice activists to support restrictions on parents’ rights to germinal choice. The ecological thinktank Worldwatch Institute devoted a 2002 issue of its magazine to a dozen articles opposing cloning and human genetic engineering, written by McKibben, Fukuyama and prominent feminist and environmental writers. Testifying before the U.S. Congress in 2002 in support of a ban on the use of cloning in medical research Brent Blackwelder, president of the environmental group Friends of the Earth, said “The push to redesign human beings, animals and plants to meet the commercial goals of a limited number of individuals is fundamentally at odds with the principle of respect for nature” (Mooney, 2002). In 2003 Blackwelder joined the technoconservative Institute on Biotechnology and a Human Future as a senior Fellow.

Environmental writer Bill McKibben’s 2003 book *Enough* is an example of the merger of both New Left and deep ecological technoconservatism. As the title says, McKibben is satisfied with four score years of life, with the current technologies of modern medicine, the capacities of his brain, and the world’s level of economic development, and he thinks the rest of us should be also. He calls for the world to emulate the example of the Amish and Tokugawa Japan and turn our back on further progress in order to contemplate and appreciate the virtues of the things we have. We all need to accept, he says, “that as a species we are good enough. Not perfect, but not in need of drastic redesign. We need to accept certain imperfections in ourselves in return for certain satisfactions. . . . We don’t need to go post-human, to fast-forward our evolution, to change ourselves in the thoroughgoing ways that the apostles of these new technologies demand.”

A more extreme example of left technoconservatism is found in the manifesto of Ted Kaczynski, the Unabomber. Between 1978 and 1996, Kaczynski mailed 16 bombs to targets in academia, killing three and maiming 23. He used his bombings to blackmail the media into publishing his 35,000-word manifesto in which he specifically addresses the need to dismantle medicine along with all other parts of industrial civilization, because of the threat from human genetic manipulation. “[M]an in the future will no longer be a creation of nature, or of chance, or of God (depending on your religious or philosophical opinions), but a manufactured product. . . . The only code of ethics that would truly protect freedom would be one that prohibited ANY genetic engineering of human beings” (Kaczynski, 1996). For Kaczynski, the principal argument for destroying technological civilization was to stop genetic enhancement: “You can’t get rid of the ‘bad’ parts of technology and retain only the ‘good’ parts.”

### *Technolibertarians*

Techno-utopianism, and even bio-futurism, was a solidly left-wing phenomenon from French revolutionary Marie Condorcet (1794) and the British anarchist philosopher William Godwin’s (1842) speculations about conquering death, to the 19th-century utopian communalists like Fourier and Saint Simon, to the 20th-century Marxists J. B. S. Haldane (1923) and J. D. Bernal’s (1929) speculations about genetic engineering and cyborg implants. By the 1970s, however, the left had ceded techno-utopianism to anarcho-capitalists and libertarians.

As a consequence, when a heady mix of psychedelicists, science fiction fans, space enthusiasts, and life extensionists came together in Southern California in the 1980s, they gravitated toward the utopian anarcho-capitalism of writers such as David Friedman (1989), as documented in Ed Regis’s (1990) classic social history *Great Mambo Chicken and the Transhuman Condition*. It was this milieu that first nurtured the idea of nanotechnology, for instance. Palo Alto Eric Drexler, the founder of the Foresight Institute and author of the ur-text of nanotechnology, *The Engines of Creation: The Coming Era of Nanotechnology* (1986), was also a cryonicist, and he speculated in *Engines* on how nanorobots would enable the repair of ice-crystal-damaged cryonauts.

Out of this heady mix was born the libertarian transhumanist group the “extropians” under the leadership of the British philosophy graduate student Max More. More’s Extropy Institute developed a core set of extropian principles, such as “boundless expansion” and “dynamic optimism,” as well as intelligence augmentation, immortalism, and uploading minds into computers. The extropians attracted a large following on the new, growing



Internet, and their conferences drew many luminaries of the hip fringe of computer science, nanotechnology, science fiction, and the arts.

By the late 1990s, however, the extropian subculture had begun to lose its political homogeneity, and with the collapse of the dot-com prosperity and bubble economy in Silicon Valley, the Hobbesian free market lost its appeal. Max More renounced libertarianism, and European non-libertarian transhumanists organized the World Transhumanist Association to gather those enthusiastic about the right to use human enhancement technologies but alienated by distinctively American free-market ideology.

However, the strong relationship between libertarianism and the growing transhumanist milieu continues. For instance, Ron Bailey, the science writer for the libertarian journal *Reason* and author of *Liberation Biology: A Moral and Scientific Defense of the Biotech Revolution* (2005), is one of the most prolific transhumanist writers. The libertarian Web-zine *TechCentral Station* publishes articles by numerous transhumanist-inclined writers, such as the anti-regulatory legal scholar Glenn Harlan Reynolds. Even as the extropians try to escape from the libertarian corner of political space, transhumanist ideas are now generally taken for granted by libertarians.

From the libertarians, technoprogressivism also appears to be seeping into traditional conservatism. For instance, in January 2005 William Safire announced he was retiring from conservative punditry to devote his twilight years to advocacy for neuro-enhancement medicine at the brain science-focused Dana Foundation. “Medical and genetic science will surely stretch our life spans. Neuroscience will just as certainly make possible the mental agility of the aging. Nobody should fail to capitalize on the physical and mental gifts to come” (Safire, 2005).

### *Technodemocrats*

Although the technopolitical debate often seems polarized between libertarian technoprogressives and various technoconservatives, liberal and left-wing technoprogressives or “technodemocrats” are now emerging in many quarters. Technodemocrats defend the idea the human condition can be improved with technology but insist that regulation ensure the safety of the technologies and that they be made universally accessible.

In bioethics, for instance, egalitarian philosophers such as John Harris (1992), Peter Singer (2002), Glenn McGee (2003), Ronald Dworkin (2000), Julian Savulescu (2001), and Allen Buchanan, Dan W. Brock, Norman Daniels, and Daniel Wikler (2000) are openly arguing against natural law-based bans on enhancement and procreative liberty, and for universal access policies that ameliorate the potential inequities of procreative liberty and enhancement medicine. Advocates of drug policy reform, such as the Center for Cognitive Liberty and Ethics, are struggling to frame transhumanist

policies that would protect individual freedom to use brain-enhancing technologies while protecting brain privacy against surveillance and control technologies. Pro-technology disability activists, such as the late Christopher Reeve, have begun to resist the disability movement orthodoxy and campaign for cures for their paralysis, blindness, and deafness. A dissident school of pro-technology “cyborgologists” in the humanities, inspired by Donna Haraway’s seminal “Cyborg Manifesto” (1984), are problematizing the romantic dualisms of left technoconservatism and are offering Haraway’s idea of the transgressive cyborg as an empowering identity. Gay and transgender activists are rejecting the idea that biology must dictate gender, reproduction, and sexual preference and are arguing for their right to use reproductive and body-shaping technologies.

Some advocates of environmentalism are also setting aside knee-jerk opposition to new technologies and exploring ways that nanotechnology (Mulhall, 2002) and genetic engineering (Center for Global Food Issues, 2004) might benefit humanity. The AgBioWorld Foundation at the Tuskegee Institute has mobilized a global network of biotech scientists to defend genetically modified crops on humanitarian and ecological grounds. For instance, crops can be genetically engineered to require less agricultural land, pesticides, and fertilizer and to provide more essential nutrients. In its 2003 review of nanotech and AI titled “Future Technologies, Today’s Choices” (Arnall, 2003), Greenpeace says there is no need for bans on nanotech, or even for new regulatory structures, and that “new technologies . . . are also an integral part of our solutions to environmental problems, including renewable energy technologies such as solar, wind and wave power, and waste treatment technologies such as mechanical-biological treatment.”

Although various kinds of political progressives are reasserting a positive approach to technology, the strongly libertarian transhumanist movement is developing a left-of-center wing. The World Transhumanist Association was founded in 1988 by the Swedish philosopher Nick Bostrom and British philosopher David Pearce. It represented European fellow travelers of the extropians, whose politics ranged from Green and social democrat to Euro-Liberal. The WTA now has 3000 members and 25 chapters in 100 countries around the world. Membership surveys have shown that although the extropians are more than 50% libertarian or anarchist, the membership of the World Transhumanist Association is only about 25% libertarian and about 35% left-leaning and 45% moderate or apolitical.

### **The Politics to Come**

Compared to the well-organized, well-funded, and politically connected technoconservatives, the technoprogressives and transhumanists are as yet a rag-tag and scruffy subculture, with little political influence or organizational

heft. However, they do have the enormous advantage that it is easier to sell technological progress, health, beauty, youth, and life than it is to sell simplicity, sickness, aging, and death. Perhaps it is in recognition of their attractiveness that technoconservatives like Francis Fukuyama suggest that technoprogressive ideas are so dangerous. Certainly, if the technoconservatives are successful in delaying or banning human enhancement technologies, it appears likely that there will be a rapid growth in pro-technology coalitions and campaigns, combining libertarians and social democrats, that would be parallel to the left-right technoconservative coalitions.

Some of the areas of conflict likely to force a crystallization and polarization along the technopolitical axes include

- Demands of the growing senior population for anti-aging research and therapies, in the context of increasing conflict over generational equity and the tax burdens of retiree pensions and health care
- Food and Drug Administration approval of gene therapies, psychopharmaceuticals, and nanocybernetics for “enhancement” purposes, such as improving memory, mood, senses, life extension, and athletic performance
- Perfection of neonatal intensive care and artificial uteruses that eroded the current political compromise on fetal rights, predicated on “viability” as a moral dividing line
- The intellectual enhancement of animals, forcing a clarification of the citizenship status of intelligent non-humans
- The regulation of the potentially apocalyptic risks of nanomaterials, nanomachines, genetically engineered organisms, and artificial intelligence
- Parental rights to use germinal-choice technologies to choose enhancements and aesthetic characteristics of their children
- Proliferation of wearable, implanted, and ubiquitous computing, progress with direct brain–computer interfaces, and widespread use of “cyborg” technologies to assist disabled people.

These possibilities will probably generate as much support for technoprogressivism as they do technoconservative backlash, but if democratic polities are able to mediate these technopolitical debates in a way that ensures that new technologies are adopted, but are made safe and widely available, we may end up with unimaginably improved lives and a safer, healthier, more prosperous world.

## References

- Annas, G. J. 2000. The man on the moon, immortality, and other millennial myths: The prospects and perils of human genetic engineering. *Emory Law Journal* 49(3): 753–782.
- Annas, G. J. 2001. Genism, racism, and the prospect of genetic genocide, presented at the World Conference Against Racism (September).  
www.thehumanfuture.org/commentaries/annas\_genism.htm
- Arnall, A. H. 2003. Future technologies, today's choices: Nanotechnology, artificial intelligence and robotics; a technical, political and institutional map of emerging technologies. Greenpeace.  
www.greenpeace.org.uk/MultimediaFiles/Live/FullReport/5886.pdf
- Bailey, R. 2005. *Liberation Biology: A Moral and Scientific Defense of the Biotech Revolution*. Amherst, N.Y.: Prometheus Books.
- Beauchamp, T. L., and J. F. Childress. 1994. *Principles of Biomedical Ethics*. New York: Oxford University Press.
- Bernal, J. D. 1929 [1969]. *The World, the Flesh and the Devil: An Enquiry into the Future of the Three Enemies of the Rational Soul*. Bloomington: Indiana University Press.
- Bostrom, N. 2004. Transhumanism: The World's Most Dangerous Idea? *Beterhumans*. www.nickbostrom.com/papers/dangerous.html
- Buchanan, A., D. W. Brock, N. Daniels, and D. Wikler. 2000. *From Chance to Choice: Genetics and Justice*. New York: Cambridge University Press.
- Carroll, J. 2001. Nine in 10 Americans oppose human cloning: A majority of Americans also oppose animal cloning. Gallup Organization.  
www.gallup.com/content/login.aspx?ci=4468.
- Center for Bioethics and Culture. 2002. *Manifesto on Biotechnology and Human Dignity*. www.thecbc.org/redesigned/manifesto.php
- Center for Global Food Issues. 2004. Declaration in support of protecting nature with high-yield farming and forestry. www.highyieldconservation.org/declaration.html.
- Condorcet, M.-J. 1794 [1955]. *Sketch for a Historical Picture of the Progress of the Human Mind*. London: Weidenfeld and Nicolson.
- Darnovsky, M. 2001. Human germline manipulation and cloning as women's issues. *Genewatch* 14(4)www.gene-watch.org/genewatch/articles/14-4germlinewomen.html
- Drexler, E. 1986. *The Engines of Creation: The Coming Era of Nanotechnology*. New York: Anchor Books.
- Dworkin, R. 2000. *Sovereign Virtues*. Cambridge, Mass.: Harvard University Press.
- ETC Group. 2003a. Size matters! The case for a global moratorium.  
www.etcgroup.org/article.asp?newsid=392.
- ETC Group. 2003b. *The Strategy for Converging Technologies: The Little BANG Theory*. March/April. www.etcgroup.org/article.asp?newsid=378.
- Fletcher, J. 1974. *The Ethics of Genetic Control: Ending Reproductive Roulette*. Garden City, N.Y.: Anchor Press.
- Friedman, D. D. 1989. *The Machinery of Freedom: Guide to a Radical Capitalism*. La Salle, Illinois: Open Court.

- Fukuyama, F. 1992. *The End of History and the Last Man*. New York: Maxwell Macmillan International.
- Fukuyama, F. 2002. *Our Posthuman Future: Consequences of the Biotechnology Revolution*. New York: Farrar, Strauss, Giroux.
- Fukuyama, F. 2004. Transhumanism. *Foreign Policy* (September–October) [www.foreignpolicy.com/story/files/story2667.php](http://www.foreignpolicy.com/story/files/story2667.php).
- Gaskell, G., N. Allum, and S. Stares (eds.). 2003. *Europeans and Biotechnology in 2002: Eurobarometer 58.0*. London School of Economics. [europa.eu.int/comm/public\\_opinion/archives/eb/ebs\\_177\\_en.pdf](http://europa.eu.int/comm/public_opinion/archives/eb/ebs_177_en.pdf).
- Genetics and Public Policy Center. 2002. Americans deeply divided about use of genetic technologies in reproduction. [www.dnapolicy.org/research/reproductiveGenetics.jhtml?subSection=reproductive](http://www.dnapolicy.org/research/reproductiveGenetics.jhtml?subSection=reproductive).
- Godwin, W. 1842. *Enquiry Concerning Political Justice and its Influence on Morals and Happiness*. London: J. Watson.
- Haldane, J. B. S. 1923. Daedalus, or, science and the future. A paper read to the Heretics, Cambridge. [cscs.umich.edu/~crshalizi/Daedalus.html](http://cscs.umich.edu/~crshalizi/Daedalus.html)
- Haraway, D. 1984. The ironic dream of a common language for women in the integrated circuit: Science, technology, and socialist feminism in the 1980s or a socialist feminist manifesto for cyborgs. *Socialist Review* 80: 66–80.
- Harris, J. 1992. *Wonderwoman and Superman: The Ethics of Human Biotechnology*. New York: Oxford University Press.
- Hook, C. 2004. The Techno Sapiens are coming. *Christianity Today* (January). [www.christianitytoday.com/ct/2004/001/1.36.html](http://www.christianitytoday.com/ct/2004/001/1.36.html).
- Hughes, J. 2004. *Citizen Cyborg: Why Democratic Societies Must Respond to the Redesigned Human of the Future*. Cambridge, Mass.: Westview Press.
- Kaczynski, T. 1996. The unabomber manifesto. [www.unabombertrial.com/manifesto/](http://www.unabombertrial.com/manifesto/)
- Kass, L. R. 1997. The wisdom of repugnance: Why we should ban the cloning of humans. *The New Republic* 216: 17–27.
- Keiper, A. 2003. The nanotechnology revolution. *The New Atlantis* 2. [www.thenewatlantis.com/archive/2/keiper.htm](http://www.thenewatlantis.com/archive/2/keiper.htm).
- Kimbrell, A. 1993. *The Human Body Shop: The Cloning, Engineering, and Marketing of Life*. San Francisco: Harper Collins.
- Macer, D. 1994. Universal bioethics and the human germ-line. *Politics and Life Sciences* 14: 27–29.
- Maddox, W., and S. Lilie. 1984. *Beyond Liberal and Conservative: Reassessing the Political Spectrum*. Washington, D.C.: CATO Institute.
- McGee, G. 2003. Leon the professional. *American Journal of Bioethics* 3(3): 7. [www.bioethics.net/journal/index.php?jid=11](http://www.bioethics.net/journal/index.php?jid=11)
- McKibben, B. 2003. *Enough: Staying Human in an Engineered Age*. New York: Owl Books.
- Mitchell, C. B., and J. F. Kilner. 2003. Remaking humans: The new utopians versus a truly human future. [www.cbhd.org/resources/bioethics/mitchell\\_kilner\\_2003-08-29.htm](http://www.cbhd.org/resources/bioethics/mitchell_kilner_2003-08-29.htm).
- Mooney, C. 2002. When left becomes right: The strange case of Friends of the Earth. *American Prospect*, January 29. [www.prospect.org/webfeatures/2002/01/mooney-c-01-29.html](http://www.prospect.org/webfeatures/2002/01/mooney-c-01-29.html)
- Mooney, P. 2003. Making well people “better.” *World Watch* (July/August): 13–16.

- Mulhall, D. 2002. *Our Molecular Future: How Nanotechnology, Robotics, Genetics, and Artificial Intelligence Will Transform Our World*. Amherst, N.Y.: Prometheus Books.
- Naess, A. 1989. *Ecology, Community and Lifestyle*, Cambridge: Cambridge University Press.
- Naess, A., and G. Sessions. 1993. The deep ecology platform. In B. Devall (ed.), *Clearcut: The Tragedy of Industrial Forestry*. San Francisco: Sierra Club Books and Earth Island Press.
- National Science Foundation. 2000. *Science and Engineering Indicators 2000*. [www.nsf.gov/sbe/srs/seind00](http://www.nsf.gov/sbe/srs/seind00).
- President's Council on Bioethics. 2003. *Beyond Therapy*. New York: Regan Books. [www.bioethics.gov](http://www.bioethics.gov).
- Priest, S. H. 2000. U. S. public opinion divided over biotechnology? *Nature Biotechnology* 18: 939–942.
- Regis, E. 1990. *Great Mambo Chicken and the Transhuman Condition*. Reading, Mass.: Addison-Wesley
- Rifkin, J. 1983. *Algeny*. New York: Penguin.
- Rifkin, J. 1998. *The Biotech Century: Harnessing the Gene and Remaking the World*. New York: Jeremy P. Tarcher/Putnam.
- Rifkin, J. 2001. Odd coupling of political bedfellows takes shape in the new biotech era. *Los Angeles Times* July 24. [www.commondreams.org/views01/0724-05.htm](http://www.commondreams.org/views01/0724-05.htm).
- Rifkin, J. 2002. Fusion technopolitics. *The Nation* February 18. [www.thenation.com/doc.mhtml?i=20020218&s=rifkin](http://www.thenation.com/doc.mhtml?i=20020218&s=rifkin).
- Roco, M. C., and W. S. Bainbridge (eds.). 2003. *Converging Technologies for Improving Human Performance*. Dordrecht, Netherlands: Kluwer. [wtec.org/ConvergingTechnologies/](http://wtec.org/ConvergingTechnologies/).
- Roco, M. C., and C. D. Montemagno (eds.). 2004. *The Coevolution of Human Potential and Converging Technologies*. New York: New York Academy of Sciences.
- Safire, W. 2005. Never retire. *New York Times* January 24. [www.nytimes.com/2005/01/24/opinion/24safire2.html](http://www.nytimes.com/2005/01/24/opinion/24safire2.html).
- Savulescu, J. 2001. Procreative beneficence: Why we should select the best children. *Bioethics*, 15(5/6): 413-426.
- Sessions, G. (ed). 1995. *Deep Ecology for the Twenty-First Century*. Boston: Shambala.
- Singer, P. 2002. Shopping at the genetic supermarket. [www.petersingerlinks.com/supermarket.htm](http://www.petersingerlinks.com/supermarket.htm).
- Smith, W. J. 2002. The Transhumanists. *National Review Online*, September. [20www.nationalreview.com/comment/comment-smith092002.asp](http://20www.nationalreview.com/comment/comment-smith092002.asp)
- Turner, L. 2004. Beware the celebrity bioethicist. *Chronicle of Higher Education*, May 7.
- U.S. President's Commission for the Study of Ethical Problems in Medicine and Biomedical and Behavioral Research. 1983. *Deciding to Forego Life-Sustaining Treatment: A Report on the Ethical, Medical, and Legal Issues in Treatment Decisions*. Washington, D.C.
- Winner, L. 1986. *The Whale and the Reactor: A Search for Limits in an Age of High Technology*. Chicago: University of Chicago Press.

## 19. COEVOLUTION OF SOCIAL SCIENCE AND EMERGING TECHNOLOGIES

*Bruce E. Tonn, University of Tennessee, Knoxville*

*Abstract:* The thesis of this chapter is that future technological change has the potential to radically change society, and social science along with it. Among the major technologies considered herein are information, energy, bio-, and nanotechnologies. In combination, these technologies could lead to widespread self-sufficiency, which could call into question the application of numerous standard economic theories and models. Information technology could allow the establishment of non-spatial governments, both at national and subnational levels, which could roil the world of political theorists. In combination, the technologies could lead to changes in the sources of people's identities, which in turn could pose threats to psychological health and give rise to a new group of technology-driven psychological illnesses. Last, the technologies, combined with changes in economic and political systems, could give rise to new cultures and a new, virtual cultural landscape across the planet. Use of traditional social science variables may become obsolete, to be replaced by new variables more in tune with new social realities. It is argued that social scientists will have to become more proactive in their approach to their discipline if they are to provide guidance to societies during times of rapid technologically driven change.<sup>1</sup>

### Introduction

Advances in technology ought to coevolve with advances in social science theory. Put even more strongly, new technologies will lead to revolutionary changes in society that will call into question the value and usefulness of many fundamental social science paradigms, theories, and models that underpin several social science fields. As these precepts wilt under the onslaught of social change, they must be replaced with even more fundamental precepts, much like the way that Einsteinian relativity replaced its predecessor, Newtonian physics, with a more fundamental understanding of physical reality.

What new technologies will lead to revolutionary changes in society? The main categories are information technology (IT), biotechnology, energy technology, and nanotechnology. It can be argued that IT has already had major impacts on society, at least in the developed countries such as the United States (Castells, 1997; Davis and Meyer, 1998; Gleick, 1999). Stewart

---

<sup>1</sup> I would like to thank Woody Dowling, Joel Eisenberg, Dennis White, and Mary English for their comments on draft versions of this chapter.

and Williams (1998) have argued that society is already coevolving with multimedia technology. It is assumed that IT will have even more substantial impacts on society in the future. It is further argued that IT is a building block for the other technologies as well. Certainly, research in genomics, material science, nuclear, and even renewable energy technologies and nanotechnology would be extraordinarily difficult, if not impossible, without advanced computing tools. Thus, it is argued that IT is a keystone technology as it both directly impacts social change and indirectly impacts social change through its use in the development of other technologies.

What will technology be like in the future that may have such major impacts on society that even the most fundamental precepts of social science will be called into question? IT has already evolved to a point at which many people have access to each other and to great stores of data, information, and knowledge from anywhere on earth at any time of the day. This technology will continue to be improved to further augment human intelligence and capabilities. Computers already exist that can process over a trillion calculations per second. Following Moore's Law, one can surmise that peta-flop machines are not far behind. Fully functional quantum computers will have almost unimaginable power. Kurzweil (1999) firmly believes that within a few decades, computers will exceed the capabilities of the human brain. There will be no bottlenecks with respect to data transfer. Combinations of fiber-optic and wireless systems will provide people, mobile units (including handheld devices), and fixed locations with multiple, high-bandwidth access. Almost every aspect of reality could be monitored in real-time, from the air that a specific person is actually breathing, to that person's vital statistics, to the price of a kilowatt-hour of electricity available to be purchased by one's intelligent home monitoring and management system, to the price of every product and service available in the economy. Artificially intelligent systems will translate languages, compose messages for their users in other languages, act as intelligent agents, provide real-time and highly reliable medical and legal advice, help people plan their days, and interact with others to plan logistics for the day's travel as well as other personal management functions.

It is necessary to look beyond ITs to gain broader insights in the overall and synergistic impacts of technology on future societies. For example, energy technologies will change radically. In the not-too-distant future, it can be predicted that renewable energy technologies, such as photovoltaics, and new technologies, such as hydrogen fuel cells and combined heat and power systems, will allow most homes and businesses to drop off the power transmission grid. In addition, advances in nuclear technology (safer fission and at some point, operational fusion plants) will allow the construction of new mega-power plants that will provide power for large-scale activities (such as aluminum plants, very large office buildings, chemical plants,



hydrogen production through electrolysis, particle colliders, and carbon sequestration machines) that cannot be serviced by more power-limited renewable and other decentralized technologies.

Advances in genetics, bioengineering, and biomechanics probably represent the biggest sources of potential societal change over the next couple of decades. Advances in these areas are already proving to be highly controversial (Frankel and Teich, 1994), as heated debates are raging about cloning, stem cell research, and human consumption of genetically modified organisms. Even at this time, genetic testing can reveal to people whether they have inherited risks for Huntington's Disease and other health problems. Following Monsanto's Law, the ability to identify and use genetic information will probably continue to double every 12 to 24 months. Taken 50 to 100 years out into the future, changes in this area become truly unimaginable. Providing a peek into the future has been the development of genetically modified fish<sup>1</sup> and rabbits that glow green in the dark,<sup>2</sup> the escape of genetically modified strains of corn into the wilds of Mexico,<sup>3</sup> and the discovery that some types of cells appear to be immortal. The day will soon come when humans will have the ability to alter and essentially create new life-forms, including our own descendants (Dyson, 1999), with an explosion of diversity possibly surpassing the Cambrian explosion of life over 500 million years ago.

Advances in computing, materials science, biology, and to some extent, artificial intelligence are converging in an area known as nanotechnology (Roco and Bainbridge, 2001). Nanotechnologies focus on constructing materials and nanoscale machines atom by atom and molecule by molecule. Much success has been achieved in this area, such as the construction of single-walled carbon nanotubes. These are cylindrical objects one carbon atom thick that have incredible properties. Their strength and light weightness make them valuable for many applications – for automobile components, for example. Nanotechnologies will eventually be developed that will be able to autonomously construct objects and materials using other atoms and molecules that will have a vast range of applications, from textiles to pharmaceuticals to building materials. It can be assumed that the machines developed to produce nanomaterials and machines will themselves be small scale, thus allowing this industry to be “decentralized” in a way analogous to small family farms rather than centralized in a way analogous to the production of automobiles.

Therefore, it can be envisioned that nanotechnologies will allow the development of small-scale yet highly productive materials production system. Massive steel mills and chemical plants will be replaced by compact

---

<sup>1</sup> [news.bbc.co.uk/cbbcnews/hi/sci\\_tech/newsid\\_3028000/3028100.stm](http://news.bbc.co.uk/cbbcnews/hi/sci_tech/newsid_3028000/3028100.stm).

<sup>2</sup> [www.ekac.org/](http://www.ekac.org/).

<sup>3</sup> [education.guardian.co.uk/print/0,3858,4387634-108239,00.html](http://education.guardian.co.uk/print/0,3858,4387634-108239,00.html).

nanotechnology machines that will be able to produce superior materials at fractions of the cost. Highly sophisticated nanotechnology systems will be composed of nanomachines, gears, and quantum computers and could possibly be self-replicating. With “nano-technology machines” and new energy technologies, homes and communities could become largely self-sufficient – not just dropping off the electricity grid but substantially dropping out of the global economy, too. Nanotechnology has as many implications for economics and communities as biotechnologies have for ethics and society.

With many technology-lead changes already permeating society, and even more substantial changes on the horizon, some people envision a future radically different from today. According to Bell (2003: 23), “... successive innovations will occur in progressively shorter time frames as each new technology increases in power and connects with others, as when advances in life sciences are accelerated by increasing computer power.” Ever-shortening time periods make the aggregate power curve “hyperexponential,” with the resulting waves of technological convergences eventually reaching the “Singularity.” Bell describes the Singularity as such: “the postulated point in our future when human evolutionary development – powered by such developments as nanotechnology, neuroscience, and artificial intelligence – accelerates enormously so that nothing beyond that can be reliably conceived” (Bell, 2003: 22).

It cannot be said with certainty when and if the world will pass through the Singularity described above, or even whether these glimpses into the future of technology even capture with much clarity what the future will be like. In fact, this discussion is designed to be thought provoking instead of a prediction. However, I do strongly believe that ITs will become even more ubiquitous, use of decentralized energy technologies will continue to increase, biotechnologies will indeed revolutionize medicine and food production and pose intense ethical questions for society, and eventually, nanotechnologies will allow small-scale manufacturing of virtually any desirable materials and products. These types of technological advancements will drive major changes in future societies.

The implications of these changes for social science are immense, if not revolutionary. I believe that social science has the responsibility to help inform society about itself. Social science also has the responsibility to provide tools to society to help organize and govern itself. Thus, social scientists collect prodigious amounts of data and develop and test numerous theories, many of which find application in policy-making contexts. Often it appears, and especially with respect to topics related to technology, that social scientists are constantly collecting data simply to keep up with changes in society. Theories may follow, but by the time they are fully conceptualized and tested, they may be obsolete for application in the newly evolved societal

contexts. Thus, to some degree, changes in society being wrought by changes in technology are proceeding without the input of social science, and therefore, it can be argued, without appropriate reflection and deliberation.

An even more problematic concern is whether the social science theories, precepts, concepts, and policy methods that are currently being used will be applicable in the future. If society passes through the Singularity, will social science as we currently know it also survive? This chapter argues that the answer may largely be no. Numerous elements of social science that many basically take for granted will become of questionable validity and value. We will need even more fundamental social science theories, methods, and concepts. Not only will social science have to coevolve with technology, but in order to be of use to society, social science will have to become more prospective and future-oriented rather than reflective and reactive.

To support the general thesis of this chapter, four areas of interest to social scientists are addressed: economics, government and politics, psychology, and culture and communities. A brief vignette of the future is presented in each section, followed by discussions of which precepts may become threatened and why. Suggestions for directions for the development of new precepts are offered but are mostly presented as topics for future research. The chapter concludes with general observations about the impacts of these ideas on the future of social science.

### **Economics**

A combination of advanced technologies, especially information, bioengineering, and nanotechnologies, has the potential to radically change developed, capitalistic economies. The economy I envision is highly decentralized and sustainable. In this future, large numbers of households and small clusters of houses are capable of meeting many of their basic needs largely independent of the national and global economies. After the initial purchase of an inexpensive array of capital equipment, the homes and clustered neighborhoods will be able to generate their own electricity, recycle their own water, assemble materials for clothing (which then can be used to make custom-designed clothing, in part using instructions available on the information network), possibly manufacture custom-designed medicines (again, using instructions available on the information network), custom produce their own reading materials and entertainment products, and even grow a fair portion of their own food, using fast-growing, genetically modified organisms grown in specially designed, real-time controlled “green” greenhouses.

People will cooperatively “work” in their homes and neighborhoods to manage these systems to produce these and other products. By implication, many people will devote less time to “traditional,” full-time jobs. However,

they will have less need for income to support themselves and their households because a large fraction of their “needs” will essentially be free. Within this scenario, jobs will need to become even more flexible (e.g., “permanent part-time”). To allow people to better manage their home-based work and their external jobs, telecommuting will probably increase appreciably. In addition, people will also be allowed to manage their home-based systems from work and other remote locations. It is also likely that distance education and other uses of IT to reduce the need for trips away from homes and neighborhoods will also increase.

Will such a scenario come about? Today’s trends suggest it very well might. The number of telecommuters is increasing.<sup>1</sup> Use of telemedicine<sup>2</sup> and tele-education<sup>3</sup> is also increasing. Costs of renewable energy systems (e.g., wind, photovoltaics, fuel cells) are continuing to decrease.<sup>4</sup> Now, approximately 30 years after the first oil embargo and in the face of potentially catastrophic global climate change, the signs are that energy independence is becoming more than an idle political promise. In fact, communities around the United States and the world are embracing the notion of sustainability (Hart, 1999) and are trying to reduce their “ecological footprints” (Wackernagel and Rees, 1996). Companies are increasingly working to reduce needs for virgin materials, reduce waste, reduce energy needed to produce products, and to practice “natural capitalism,” in the words of Hawken, Lovins and Lovins (1999). Economic globalization has shaken the foundations of once-stable communities; their natural reaction is to try to regain economic stability by reducing their dependence on “imported” products and services and reducing their reliance on “export” industries owned and managed by outsiders. Once bioengineered foods and nanotechnology-produced materials become available and affordable to households and communities and promise to bring more economic stability, communities will undoubtedly implement those technologies – and fairly quickly, given historical rates of technological change.

What are the implications of such a scenario for capitalist, macroeconomic theory? One implication is that theories about how to manage a national economy may be found out-of-step, if not at cross-currents with trends in this kind of future economy. Current economic policy seeks to promote the growth of the gross national product (GNP). In other words, macroeconomic policies are designed to increase the exchange of money between people, firms, governments, and nonprofit organizations in the economy. Reducing unemployment and controlling inflation are also

---

<sup>1</sup> [www.workandfamily.org/research/indepth/tr991123.asp](http://www.workandfamily.org/research/indepth/tr991123.asp).

<sup>2</sup> [telehealth.hrsa.gov/pubs/report2001/trends.htm](http://telehealth.hrsa.gov/pubs/report2001/trends.htm).

<sup>3</sup> [nces.ed.gov/pubsearch/pubsinfo.asp?pubid=2003017](http://nces.ed.gov/pubsearch/pubsinfo.asp?pubid=2003017).

<sup>4</sup> [.geni.org/energy/library/technical\\_articles/generation/low\\_cost\\_energy.html](http://.geni.org/energy/library/technical_articles/generation/low_cost_energy.html);  
[.ucsusa.org/clean\\_energy/renewable\\_energy/page.cfm?pageID=45](http://.ucsusa.org/clean_energy/renewable_energy/page.cfm?pageID=45).

important goals of current macroeconomic policy. The flow of money between market actors is taxed in various ways to fund the operation of government and its provision of social programs, such as social security, Medicare, and welfare. The Federal Reserve acts to manage the economy by manipulating the money supply; for example, by lowering interest rates or selling securities to increase the money supply in periods of economic downturn, and doing the reverse to decrease the money supply during periods of inflation. Political pressures on the Federal Reserve are great to increase the money supply when unemployment appears to be rising and GNP appears to be declining. At the foundation of current macroeconomic policy is increasing consumption through a market-based economy.

In the future world described above, the increasing economic independence of economic actors will most assuredly result in less exchange of money between economic agents. This is because people will need to purchase fewer goods and services and because people will earn less money, too. This means that GNP (and economic growth in the traditional sense) is likely to decrease, controlling for increases in population. This does not mean, however, that the national economy will suffer. We will need to move “beyond growth” as the paradigm for economic policies (Daly, 1996). Although classical economic growth, as measured by GNP, may not continue to increase, economic development will increase and will benefit from the use of a combination of advanced technologies.

In an economy shifted toward self-sustainability facilitated by new technologies, GNP will be even a less useful metric of economic health than it is today (Henderson, 1996). Yet, metrics to describe the new economy will still be needed. The question is, how should economic health be measured and monitored? If the rate of exchange of money decreases, and if the supply of money needed to “fuel” the economy decreases, how should the economy be managed? If the tools available to the Federal Reserve (e.g., controlling interest rates) become less relevant (along with the debate between supply-side and Keynesian economics) and effective, then what new tools could be created to help manage this new economy? If market-based consumption becomes a less important fraction of the future economy, what should be the goal of macroeconomic policy? If more and more people “work” in their homes and neighborhoods without receiving salaries (but do receive benefits from their work), how should employment be measured? Or unemployment? Macroeconomic theory tends to the conclusion that national economies cannot achieve full-employment because labor shortages would lead to wage and general inflation. In this new world, it can be argued that some type of “full employment” can be achieved without the resulting impacts on inflation. If so, how will we know whether “full employment” has been achieved?

As the exchange of money decreases, so will the receipt of sales and income taxes. As people move from a paradigm of 40-hour weeks and salaried employment to “permanent part-time” employment and non-salaried work, the basis for the pay-as-you-go social security system begins to break down. What is it other than money that people could contribute to Social Security over their working lives to help them in “retirement”? What does retirement mean in a world dominated by non-salaried work and permanent part-time employment? Unemployment payments, pensions, health benefits, and disability insurance and benefits are also tied to “full-time” salaried work. Much of people’s wealth is in the form of market-based debt, such as stocks and bonds. In the new economy, the role of traditional firms will decrease and the wealth generated by this part of the private sector will decrease. Many people rely on such wealth to help supplement Social Security and pensions after retirement. If people cannot build wealth as easily in the traditional sense but still have the need to build wealth to ensure their personal “economic” security, how will wealth be built in the new economy? How should these types of issues be handled in a new economy?

Answering these types of questions will require, in my opinion, theories that are more fundamental than are today’s macroeconomic theories. There will still be a need to help ensure that everyone is capable of supporting themselves and their families economically. However, increasing the money supply to spur investment and consumption becomes a questionable policy in this new economy, because traditional consumption is no longer driving the economy. Therefore, the economy needs to be viewed in a more fundamental way. Employment needs to be viewed in a more fundamental way, too. In this future world, what should be done to help people sustain themselves economically who either do not have the means or capabilities to gain and maintain permanent part-time positions or manage home- and neighborhood-based sustainable systems? Funding government must be rethought, too. Government financing cannot be based almost solely on taxing the exchange of money. Not only are new bases for taxes needed, but new methods to forecast these new “resource” streams would also be needed.

Microeconomics will need to change along with macroeconomics. Models of consumers will need to give way to more fundamental models of individual, household, and community-based economic behavior. Traditional labor-leisure models would need to be replaced with more sophisticated models that allow the blurring of home-based labor and leisure behavior and allow home-based labor to take place while at work. The famous income constraint in utility theory would become less important as one’s stock of “technology” available in the household and neighborhood and one’s time constraint become more important. As “money” becomes less important in the overall economy, basing economic (and even health and environmental) policy decisions on benefit-cost models in which all benefits and costs are

monetarized becomes even more problematic (Sagoff, 1988). People will not think primarily in terms of money, yet they will still have strong beliefs, values, and preferences. Thus, more fundamental methods to guide policy making will also have to be developed.

Last, the new economy will not be dominated by markets and firms. This, in my opinion, will be the biggest conceptual hurdle for traditional economists. A large fraction of the economy, in essence, will be subsistence. The private sector will sell nanotechnologies, biotechnologies, and new energy technologies and will sell some virgin materials to be used by those technologies. They could also service and recycle those technologies, but use of those technologies will displace many other current industries. Overall, the private sector will shrink. The role of firms in the economy will decline. The role of households and small-scale cooperatives will increase. The role of nongovernmental organizations like cooperatives will increase (as it already has in recent years<sup>1</sup>). As measured in monetary terms (i.e., in terms of traditionally measured GNP), the fraction of GNP represented by government may also rise in historical terms. All these trends should be seen as being positive if increases in the sophistication of the technology driving the economy and increases in the overall quality and sustainability of life are the end-goals of national economic policy.

### **Government and Politics**

Much has been made about the impact of information technology on politics (e.g., Kamarck and Nye, 1999). IT can allow the disenfranchised to organize (Longan, 2002). Political discourse in this country may be increasing because of the Internet, although the specific discourses themselves may be becoming more polemic and exclusionary rather than more tolerant and inclusive (Thompson, 1999). Politicians are using the Internet to solicit campaign contributions and to communicate virtually instantaneously with constituents, supporters, staff, lobbyists, the media, and other politicians about the day's "message." Prospects for electronic town halls and direct democracy have pretty much stayed on the horizon for a number of years now but still must be considered likely events in the future. Some believe that IT has already led to the loss of power and influence of nation states (Nye, 1999). For political theorists, the potential of direct democracy, aided by ready access of citizens/voters to the Internet for information and to vote, could call into question the need for representative democracy or bring to the forefront long-dormant arguments for and against this type of government (Kakabadse *et al.*, 2003).

---

<sup>1</sup>[www.independentsector.org/Nonprofit\\_Information\\_Center/information\\_center.html](http://www.independentsector.org/Nonprofit_Information_Center/information_center.html).

However, an even more radical potential event looms on the horizon with respect to the future of government and politics. Again consider the current and future expected capabilities of IT. IT facilitates instantaneous communication from many to many people. IT has the capability to store vast amounts of information. Many local geographic information systems (GIS), for example, have spatial databases that contain information on every parcel of property in a city – ownership, size, assessed worth, taxes owed, and so on. In addition, GISs also have spatial databases (such as the famous TIGER files produced by the U.S. Census) that contain information on roads, infrastructure, rivers and streams, and political jurisdictions. Other information in GISs include land uses, crime rates, transportation routes, school districts, and incidences of disease. Expert systems already manage vast numbers of credit card transactions and advise physicians and other professionals about diagnoses and treatments. IT facilitates the transfer of billions of dollars of money across borders every day. IT allows transnational companies to truly integrate their operations around the world, 24 hours a day, 7 days a week. IT allows travelers access to ATMs and to news across the world, either through the Web or through ubiquitous television stations like CNN. IT allows people of affinity to communicate with each other across borders, whether these people are employed by the same company, belong to the same religious organization, are refugees or rebels from the same country, or are members of international nonprofit groups.

The point of this list of seemingly random observations about IT is that in the future, we may witness the establishment of political jurisdictions that have no borders, referred to as non-spatial governments (NSGs) (Tonn and Feldman, 1995). Historically, it can be argued that a primary reason for the establishment of geographically enclosed political jurisdictions were communication and security. In the state of Tennessee, the approximate size of its counties was determined by how far one would need to ride a horse in 1 day to reach the county seat. Another reason was defense; walls, moats, and borders demarcated us from them and provided a focus for the development of defenses for the community, town, kingdom, and nation (Mumford, 1961). A third reason was related to administrative efficiency. Simply put, it was much easier to consider everyone located within the border to be part of the town, province, or country. Everyone had to follow the same laws, contribute taxes, and so on. Last, over time, people have come to identify with the land upon which they live to the extent that what appears to bind a community or nation together is their collective connection to “their land” rather than more substantial socio-psychological affiliations to each other.

Now consider the possibility of NSG as facilitated by information technology. Using IT, the communication and efficiency constraints disappear. In fact, with IT, people can theoretically live anywhere and be citizens of any state or nation. They can vote online. Government



bureaucracies can be managed by telecommuters. Government social and financial services can be delivered electronically. Provisions can be made to provide other services, such as educational and medical services, electronically or through decentralized brick-and-mortar institutions run by the governments or through equalized reimbursements to “independent” but certified institutions located where citizens live. The political system can still be based on representative democracy, or be more tilted toward direct democracy, or be some new form of a quasi-representative democracy. Experimentation with new government forms might flourish. NSGs can pass laws and collect revenues electronically (given the future constraints mentioned above). Presumably, NSGs can enforce their laws through their own courts and law enforcement agencies, again using IT to facilitate teleconferencing of legal proceedings. Theoretically, there appear to be few theoretical barriers to the establishment of NSGs.

Does the world need NSGs? Possibly. First, much of the violence around the world is in part caused by people trying to exclude others from predefined political jurisdictions. Given traditional notions of government, people seem inclined to try to expel Catholics from Northern Ireland or Palestinians from the Occupied Territories or to ethnically cleanse regions in Eastern Europe and in Central Africa. In addition, the migration of people away from regions of extreme poverty is increasing. Migration of young immigrants to aging developed countries, especially in Europe, is also increasing. Tensions between immigrants and “indigenous” populations are increasing, as the latter fear the dilution of their political power and dissolution of their cultures. Establishment of NSGs in these and other regions could possibly provide win-win solutions, as people would have their own governments and still be able to live where they so chose.

Whether or not NSGs become established tomorrow or the next day, the mere prospect for these kinds of governments poses very interesting questions to political theorists. If borders can no longer be used to demarcate political jurisdictions, what criteria can be used to support the establishment of NSGs? It can be argued that these criteria should, in some sense, be more fundamental than lines drawn on the ground, but what should they be? Answering this question will not be simple, because the answers can be both sublime and ridiculous.

Let us first examine states within the United States. In a non-spatial world, states would no longer need to have predefined physical borders. History, rivers, lakes, and oceans would cease to be important demarcations of states. If the citizens of the United States were to seriously consider revamping its system of states, they would, in effect, be saying two things: first, that being a citizen of Iowa or Mississippi or Montana really does not mean a great deal (i.e., few people can explain the difference between Iowans or Montanans, and in any case, people derive little psychological fulfillment

from what state they live in), and second, that there are much stronger ties or affinities between people other than geography that could serve as bonds to create more cohesive and psychologically satisfying states. In this world, the states, like Illinois, Iowa, Missouri, and New Jersey, might disappear because people would rather “reside” in states with people more like themselves. Residents of such states could reside anywhere within the current borders of the United States and, presumably, even overseas.

From a political theorist’s point of view, what really does this all mean? It might seem reasonable to allow people to become citizens of states based on their support or lack of support for government (e.g., along a liberal versus conservative axis). But would it be reasonable to allow states to form along strictly religious affiliations (e.g., would states of Southern Baptists or Muslims or Scientologists be permissible), as was partly the case at the very beginning of the history of the United States? Would the formation of states along racial or ethnic affiliations be permissible (e.g., states composed of Mexican Americans or Asian Americans)? Or based on lifestyle patterns (e.g., nonsmoking, exercise enthusiasts)? Or based on professional affiliations (e.g., teachers), or simply based on income (as many of our exclusive suburbs and gated communities already represent)? Are there any so-called affiliations that are unsuitable, unacceptable, or unethical to justify the establishment of a new state (e.g., a state of people who believe in the legalization of marijuana or a state of people who speak Klingon)?

Political theorists would need to devise some guidelines for granting people the ability to establish a state. The theorists would also have to tackle a host of issues: are there minimum or maximum sizes for states (right now the range is some where between 500,000 and 40 million)? How would people “move” from state to state? Because place of residence automatically does not determine state citizenship, could NSGs deny “virtual” immigration – something that is not now allowed when someone physically moves from one state to another? Could citizens be expelled from their states if they stray from the main motivations for the state, and if so, “where” would they go? What would be done about “stateless” U.S. citizens, and how would citizenship of newborns be decided, especially in instances in which the parents who actually share accommodations with each other are citizens of different states?

Another topic deals with “redistricting” for the purpose of electing representatives. Curry (1999) reports that redistricting using GIS tended to ignore facts on the ground, such as natural boundaries of neighborhoods. In a non-spatial world, how would redistricting within a state work at all? Maybe new ideas are needed to underpin basic representative government. For example, using a sophisticated IT system, people could pledge support to their “Decision Maker,” who in turn could support higher-level government officials. The key to this model is that people ought to personally know their

Decision Maker, their representative who actually votes on new legislation. Thus, a cap is needed on the number of supporters a Decision Maker can have – say, 200 – as long as there is a minimum of supporters – say, 100 (Tonn, 1996).

In the end, after all this analysis, it may seem that it is not worthwhile to allow non-spatially defined states because there are no affinities strong enough or defensible enough to abandon geographical boundaries that force people to live together. Extensive analysis of allowing affinities to drive the creation of states may lead to a nihilistic conclusion that it is impossible to judge where the line ought to be drawn between acceptable and unacceptable affinities around which to create states. It may even be concluded that no affinities are completely justifiable because there are no ethically justifiable ways to argue that people are so different from each other that they ought to be allowed to form a state together. In any case, it can be argued that the existence of information technology and its potential to allow NSG will sooner or later prompt a more fundamental assessment of key political and governance concepts.

In my own opinion, in the future we may see a matrix organization of states. On the ground, areas may be demarcated by environmental criteria, such as by watersheds or major ecosystems. People living in these areas will be citizens of these areas and will participate in decisions to protect and maintain these areas. In addition, people will also belong to their “affinity” states, which will provide their social services and govern their behaviors. The environmental areas will be attractive because there are real, tangible principles involved in their demarcation. The environment is also an issue that transcends individual preferences for affiliation. This will help overcome a total void in having any principles to organize people in any fashion. In addition, the environmental theme underlies, to a large extent, the potential economic system changes mentioned above, especially the goal of self-sufficiency in a sustainable framework. In any case, it can be argued that the existence of IT and its potential to allow NSG will sooner or later prompt a more fundamental assessment of key political and governance concepts.

Of course, these same sorts of issues arise at the level of nation states. However, consideration of NSG at the nation–state level seems to be more important, if only because people are dying every day because of their inability to live within the same borders with other people. In addition, at first glance, bonds tying people together appear to be stronger at a nation–state level than at the level of a state or province. Bonds can relate to ancient tribal affiliations, language, culture, and historical occupation of “special lands.” In many instances, national borders have not been set by natural geographic features but, instead, have been created by colonial powers that ignored on-the-ground situations. Still, the big question remains: What criteria ought to be used to justify the creation of a new, non-spatial nation? If the Middle East

were to be composed of a group of non-spatially defined nations, what would those nations be? Only non-spatially defined Israel and Palestine? What about Christians living in the region? Should they have their own nation? Or different sects of Muslims? Or different groups of Jews? Or those Muslims who want to live in a democracy versus those who wish to live in a theocracy? Who, ultimately, decides whether a new government can be established and accepted globally? The United Nations? Some other institution? Only the people themselves? It seems as though many fundamental questions remain. These questions need to be answered before the establishment of NSGs, rather than after years of theorizing and data collection after the fact, which poses a challenge to social scientists struggling with issues of peace and international politics.

To conclude this section, it needs to be emphasized that be they traditional or NSG in nature, the economic scenarios presented in the previous section will prove challenging to governments in many ways. Many issues that need to be confronted are related to the provision of social services. Mentioned above were issues related to Social Security, disability insurance, and dealing with unemployment. Funding government services will also prove to be challenging in the future.

One particularly interesting problem governments will need to face involves helping the less fortunate in society. At present, the basic model involves collecting taxes and redistributing income in the form of direct payments, subsidies, food stamps, and so forth, which help people exist in the market-based economy. In the future, the task could be more difficult. If the economy moves toward self-sustainability, then the task for governments will be to help those people who are not part of a self-sustainability cooperative, who cannot afford the new technologies, or who are unable to contribute to their own self-sustainability. Providing money only helps solve the second problem. Helping people find and become part of “cooperatives” appears to be a much more thorny proposition. Even more daunting is finding cooperatives to take in the chronically indigent.

### **Psychology**

Changes in economic production, government and politics, and society in general (which is discussed in the next section) will surely impact human psychology. Conversely, it can be argued that human psychology is really the fundamental force for change, as human desires, motivations, aspirations, drives, tastes, preferences, and curiosities underlie all human behavior, whether that behavior seeks to maintain the past or push towards enticing yet essentially unknown futures. In line with the theme of this chapter, technology and its impacts on human psychology will coevolve over time. Basic human motivations will not change, as they are a fundamental

expression of the human genetic code. These may include those articulated by Maslow (1970), who said that individuals have hierarchal needs that include physiological needs and self-actualization; Rogers (1959), who articulated individuals' need for unconditional love; McClelland (1961) who argued that people have a fundamental need for achievement; and the collective unconscious, as articulated by Jung (1959). However, how people satisfy their psychological needs may change. This section focuses on the issues of identity and mental health.

With respect to identity, the main argument is that people's sources of identity will change and become more sophisticated. Most people will be able to handle this brave new world, but many will not. Let us first review typical sources of human identity. These include one's sex, physical attributes, level of intelligence, race, ethnicity, economic class, job, nationality, religion, place of birth, current place of residence, language, dress, tastes in consumer goods and services, and affiliations with various volunteer groups. Many of these sources of identity have traditionally been virtually immutable – one was born with most of one's components of identity, and other components were “socially inherited” such as economic class, religion, and lifestyle.

In the future world described above, much more of one's identity will be decided by individuals themselves (Cote and Levine, 2002), and other aspects of identity will become less relevant. For example, economic class and occupation may become less important aspects of identity. In a self-sustaining economy, one can envision fewer disparities in economic wealth, with concerns about wealth possibly being replaced with concerns about the superiority of one's self-sustaining situation. Because many people will be permanent part-time workers, career and job titles may also become less important.

Tastes in consumer goods and services will be less important, as there will be less traditional consumption. However, because of the wonders of IT and nanotechnology and local applications of biotechnologies, people will have a tremendous amount of freedom to tailor their own patterns of consumption. Their nanomachines will be able to produce any type of materials; the interiors of their homes will be able to take on any forms, as smart walls can be changed at a moment's notice; and information streams from anywhere in the world or generated by powerful computers can create virtual displays and images central to decorating the interior. People living in Siberia could live like and eat like people living in Hawaii. People living in Mexico City could live like and primarily communicate with people who identify themselves as Japanese (existence of NSGs would presumably support such behavior, but their presence is not a sufficient or necessary condition for such behavior). People will be able to mix and match foods, dress, language, behaviors, and so on to create new identities related to

community, production, and consumption. In turn, these freedoms of choice may lessen the importance of those aspects of ethnic and racial identities related to foods, dress, and so forth as they become more ubiquitous, less confined to identifiable groups of people, and more open to choice.

We already live in a world in which one's physical appearance can be altered in many ways, through surgery, Botox, and physical conditioning, so although this aspect of identity may maintain its importance, physical appearance will increasingly be a choice rather than an inheritance. People may be viewed as "engineered" or "natural" rather than beautiful or ugly. People may be also categorized as "cyborgian" (Gray, 2001) or "unenhanced" rather than talented or not. Silver (1997) uses the terms "GenRich" and the "Naturals" to describe this dichotomy. Crawford (1996) suggests that nanotechnologies could be produced even to allow people to choose the color of their hair and skin. Of course, because of advances in genetics, one's parents may have increasing impacts on the physical traits their children are born with. Thus, an integral part of one's identity may become whether one was "genetically engineered" before birth or not. One can argue that this aspect of one's identity will quickly supercede one's race, as this latter aspect of one's identity will be decisively shown to be quite superficial in the overall scheme of things in relation to overt, premeditated, prenatal genetic engineering.

One's intelligence may be rather fixed at birth, but through various IT aides, one's overall behavior, and therefore one's image to others, may appear to be more intelligent. Thus, if most people act "intelligently," this aspect of identity may become less important. Along these lines, one's educational background may become less important in a world in which IT can answer any of your questions and support continuous, real-time, and ubiquitous lifelong learning. IT may also make language differences less important.

As mentioned in the previous section, people may, at some point in the future, be able to choose their nationality or political jurisdictional affiliations within nations. This prospect has two distinct impacts on identity. First, people will have the freedom to shape their own national and political identities. Second, given this freedom, this aspect of identity may become more important, as it will be the result of choice, not inheritance. However, the question remains of what the source of the affiliation will be. If race and ethnicity become less important because of technology change, then maybe those traditional sources of affinity will be less important sources of identity. In the end, it could be that no affinities upon which to build states or nations from scratch appear to be defensible. If this ends up being the case, then substantial aspects of one's identity essentially disappear, leaving questions about what will be the sources of good mental health in the future.

What are the threats to good mental health in the future? Certainly, today, the threats are numerous in all societies. In developed countries, the threats are high, as indicated by high rates of suicide, prolific use of antidepressants and other drugs targeted at managing psychological health, high levels of illegal drug use, and growing levels of obesity and associated worries about self-esteem. The questionable state of society's current mental health may be correlated with immense pressures on young people to meet academic and social expectations, on working people to maintain their jobs in the flux of globalization, on families struggling to keep up while parents often work multiple jobs at all hours of the day, and on older persons trying to maintain their economic security and dignity during the "golden" years of their lives. Even with all these pressures, there are stabilizing themes throughout society that can facilitate mental health. Most people share common beliefs about the economic and political systems and about the important constituents of one's identity.

As discussed above, however, economic and political systems, as spurred by technology, are poised for major transformation, and the fundamental building blocks of personal identity are also open for replacement. What criteria should people use to choose their identity? How can people decide to be GenRich or Natural or to change their skin color? How should people go about deciding what affinity groups, states, or nations to belong to? How can they go about designing their online, custom-designed holographic images to represent themselves? Having so many degrees of freedom to create one's identity without some guidance may lead many to feel confused, uprooted, and anxious. The whole issue of personal identity may prove as nihilistic as that of deciding on what are justifiable affinities for states and nations. One can argue that in this potential state of identity flux, the most important inherited aspect of one's identity, one's sex, may take on much more importance in the future. In summary, it appears that technologically driven changes in society could put enormous stresses on people as they cope with issues of personal identity, which could possibly lead to more people struggling to maintain their psychological health.

In addition to these points, there are any number of other issues or threats to good mental health attributable to technology change. One issue is related to the aging of the population. Biomedical technology is advancing at such a rapid pace, and lifestyles of many people are evolving to be more healthy, that some predict that the average life spans of human beings will soon be over 100 years, maybe as much as 125 to 150 years. MacGregor (2003) discusses the point that people may not be psychologically prepared for such long life spans. Psychologists have focused for many years on developmental issues associated with the beginning of people's lives, but what about issues in very old age? Can people periodically cleanse themselves of decades of "insults" that constitute our everyday lives, or will

these insults build up to such an extent that mental health is an impossible goal for a person's remaining 25 to 75 years? Does retirement have the same meaning in a world in which people would retire during the middle of their lives? To what extent can mental acuity be maintained, assuming that medical science is able to keep all other body functions in top shape for many more years? Of course, the whole issue of identity arises again, as what elements would compose the personal identity of a 140 year old?

As mentioned above, it can be argued that people will opt for lifestyles that will improve their chances at living longer (hopefully more fulfilling) lives. Bostrom (2003) envisions the use of advanced IT to create intelligent risk agents that would always accompany their owners. These risk agents would process information from the environment about real-time and pending situations and communicate to their owners real-time risk assessments. At first glance, having a risk agent seems like a wonderful idea, but with a bit more examination, the use of this technology brings up very interesting and challenging psychological issues. Bostrom (2003) discusses that we need to know more about people's values and how they would react to having such information in real-time. Would this information be a blessing or a curse? There are fundamental issues in human psychology posed by such technology that will need to be seriously addressed.

To conclude this section, it is reasonable to assume that the new technologies will give rise to a new crop of psychological illnesses. To speculate, for example, people slaved to computer-mediated communication could become afraid of interacting with other people in actual face-to-face situation (something we might call syncrophobia). Others may become addicted to the immense flow of real-time information about everything in the world (a disorder we might call psychomnipencemania). Conversely, it will be possible to pretty much document and store digitally everything about one's life, from the first days past inception through growth in the womb to birth to every day of one's life, through webcam technology. Will people who are constantly exposed to past images of themselves find this psychologically satisfying as they age, or will it create psychological dissonance about one's true self (something we might call chronoschizophrenia)? Last, it is possible to envision a situation in which one's autonomous intelligent agents are programmed to constantly complement, praise, and flatter their owners. Could people become addicted to cyber-narcissism?

### **Culture, Communities, and Social Science**

It is assumed that culture subsumes economics, government, and politics and is driven, in part, by human psychology. We have seen above that technology has the potential to radically change economic and political



systems and alter fundamental notions of human identity. The main question addressed in this section is, What might be the impacts of technology upon culture, independently and in combination with the other impacts already discussed? Other questions to be addressed include impacts upon communities and the impacts upon social science.

Historically, cultures have had spatial delineations. In the distant past, cultures were mainly local. Clans and tribes, although intermingling with neighbors, developed their own languages, norms, rituals, dress, behaviors, and so on. Coincident with the rise of agriculture was the emergence of more dominant cultures. Various groups of people took turns expanding their kingdoms into empires, spreading their culture to conquered lands. In addition, local groups began to band together into larger groups, and eventually into nations. Although diversity has always been a part of any culture, these processes brought into being what have been labeled as Greek, Roman, Egyptian, and Chinese cultures, among many others. Many local cultures survived this period of cultural consolidation but are now being lost to larger forces of globalization, led by “Western culture.” Conventional wisdom holds that virtually complete cultural homogenization, characterized by market-based economies, the English language, and Western popular culture, is what the future holds in store for the world’s societies. In this future world, the clash of cultures predicted by Huntington (1996), as appears to be playing out in the Middle East at this time, will slowly dissipate as all cultures fade into one large, homogeneous world culture.

Factoring technology into the equation – especially small-scale, decentralized production technologies and powerful information technologies – may yield a similar result – the reduction of the threats of violent clashes of world cultures – but through much different means. In fact, it is easy to envision a world more like the distant past than a homogenous future. The biggest difference will be that cultures will not, for the most part, have spatial delineations. In fact, “distance” as a topic of social concern may be superseded by “time” in importance. In addition, given that there are already over six billion people in the world, with the possibility of the population passing 10 billion in the not too distant future, it can be argued that culture will essentially become a continuous variable along many vectors, maybe not as discrete as in the past but certainly not homogeneous, either. Murdock (1945) conceptualized culture as having at least 67 universals of order. Building on this work, Hallpike (1986) estimates that there could be approximately  $10^{143}$  different variations of culture. Of course, this work was completed before the potentialities of the new technologies discussed here were even imaginable. In any case, the important point is that the “solution space” of potential cultures is quite large and, historically, humans have only experimented with a few. In the future, many more cultures will be simultaneously extant and interconnected with each other, but probably on

much smaller scales than kingdoms and empires. In fact, the fabric of culture worldwide may come to resemble the Web, which Weinberger (2002) describes as “small pieces loosely joined.”

What types of themes will characterize these small pieces loosely joined? The most powerful image of future cultures involves people who become almost completely dependent upon information technologies. These people, to whom I have referred as Home Dwellers elsewhere (Tonn, 2002), pretty much live most of their lives in their homes, which could be located in urban, suburban, or rural environments. Their homes and neighborhoods are nearly self-sufficient (i.e., they possess the full complement of off-grid energy technologies, water recycling systems, and intelligent nanotechnology systems as well as multiple high-bandwidth telecommunication channels and powerful, embedded computing systems). In addition, they telecommute and partake of distance education and telemedicine services. Entertainment is IT based. Their communities are virtual for the most part. These virtual communities, which could be networked throughout the world, could evolve any number of new “cultures.” One can imagine the evolution of new languages, being combinations of spoken and computer-generated images. For example, King (2001) documents aspects of new language developed by Internet users to describe themselves. People may begin to communicate directly using “encrypted” language. Norms associated with computer-mediated communications could be different than norms in “face-to-face” societies. Dress, foods, rituals, and architecture (especially indoor) could be anything, everything, or nothing. Myths associated with seasons and Mother Earth could be replaced by myths associated with the birth of cyberspace. People’s identities will be computer mediated, which means that emphasis on actual physical appearances will be less than in other cultures. We could witness new cyber-funeral rituals associated with the death of one’s avatar, to be resurrected or reincarnated in other forms. People may also become immortalized in eternally administered Web sites. However, computer-mediated identities may be experienced as less real, as much more ephemeral, which in turn may lead to psychological problems. These new cultures could be characterized by transience with respect to community membership, maybe even with respect to citizenship at state and national levels, which also may lead to psychological anxieties.

Almost the polar opposite of Home Dwellers are people to whom I refer as Islandians. Following from the utopian novel entitled *Islandia*, written by Austin Tappen Wright (1942), Islandians are also self-sufficient and technologically sophisticated but are tied to the land and are very community oriented. Renewable energy, self-sufficiency in food production (built upon “safe” genetically modified organisms), nanotechnology systems to produce textiles and building materials, and convenient information technologies are used by Islandians. Unlike Home Dwellers, Islandians mostly work in their

rural (and converted suburban) communities to produce most of the products and services that they need. Islandian communities will be local in scope, although one can expect large numbers of these communities to be networked. These communities could evolve their own cultures, as their languages change reflecting local technologies and production methods. Local communities could even evolve their own foods (especially if they could produce novel genetically modified foods), clothing styles, rituals and religious preferences, and family structures. Islandians will have strong identification with their communities and may identify much less with nation states. Ties to ancestors and descendants will be strong. The most important myth in this type of culture could be the journey, as these people will have very long-term perspectives and devotion to future generations.

A third group of people I refer to as the Jetsons. These people are cosmopolitan. They tend to live in renovated urban cores or well-settled suburbs. Their culture is polyglot, meaning that it is expected that they should experience and be knowledgeable about a wide range of now “historical” cultures. They are expected to eat a range of foods from these different cultures, intermingle and marry people with different backgrounds, explore different religious perspectives, and experiment with different modes of dress. This culture is an amalgam of other cultures; cultural differentiation is hard to pinpoint, but differences among groups of people will be discernable nevertheless. Continuous differentiation is probably a better description. Advanced technologies also reduce work burdens on these people. However, identity is much more tied up with one’s physical appearances and mental capabilities than in the other two scenarios mentioned above. It can be envisioned that people in this world will make much more use of genetic engineering to change their own appearances and fashion the characteristics of their children. Subcultures of Jetsons who have or have not engaged in genetic engineering may evolve. New prejudices and biases may evolve, and new forms of discriminatory behavior may also evolve. Competition and hero myths may be important in these cultures.

Immigrant populations will become endemic in the near- to mid-future. Of course, war and other violent conflicts have led to large population relocations, as have individuals’ desire to migrate to countries with more stable political systems and better economic opportunities. We are also seeing the need for many developed countries to attract immigrants from other countries to help prop up their aging societies. In addition, in the future, environmental conditions, such as a sea-level rise caused by global warming, could lead to massive population relocations. For example, it is forecast that as much as one-sixth of Bangladesh will succumb to sea-level rise.<sup>1</sup> These people will have to move elsewhere or perish. These population movements

---

<sup>1</sup> [www.grida.no/climate/vital/33.htm](http://www.grida.no/climate/vital/33.htm).

will drive consideration of non-spatial governments at the nation–state level. The immigrants may maintain their “cultures” and their ties to their fellow citizens. They could live anywhere in any country – from urban areas to rural areas. Their identities may be shaped by their outsider status to a large extent, but they will have to adopt lifestyles such as those mentioned above.

Much has been written about the impact of IT on communities. To some, IT increases community, although community is seen as more virtual than on the ground (Rheingold, 2000). In this viewpoint, people benefit from belonging to virtual communities composed of people who share interests and affinities. In this way, the rise of virtual communities and the possibility of NSGs are inextricably linked. However, presumably, people can belong to more virtual communities than they can NSGs. Thus, people could benefit from being part of a community of whitewater rafters or to a political party or to a local church or to an association of world travelers. In contrast, some believe that IT has reduced community in the United States – at least community defined using spatial concepts (Abramson, 1998). People who live in close proximity to each other have less dialogue, are less able to interact civilly in the public sphere, have less common interests, are less likely to help each other in times of need, and are less likely to volunteer to support “community” activities like Little League. In the words of Robert Putnam (2000), our society has lost valuable social capital, in part because of the alienating impacts of information media (such as television). Certainly, this is the world captured by the Home Dwellers scenario.

### **Impacts of Technology-Induced Social Changes on Social Science**

The thesis of this chapter is that new technologies may have significant impacts upon societies and, in turn, upon social science in the future. Some believe that technology is changing so rapidly that the world will pass through a Singularity, where the world on the other side is completely unpredictable. Whether this will happen or not is debatable. However, what is not debatable is that the future does hold the potential for enormous changes in technology. It is argued that information, energy, bio, and nanotechnologies have the most potential to impact societies and social science.

It was shown how a combination of these technologies could lead to widespread self-sufficiency, which could call into question numerous standard economic theories and models. Information technology could allow the establishment of non-spatial governments, at both national and subnational levels, which could roil the world of political theorists. The technologies could lead to changes in people’s identities, which in turn could pose threats to psychological health. The technologies could also give rise to a new group of psychological illnesses. Last, the technologies, combined

with changes in economic and political systems, could give rise to new cultures and a new, virtual cultural landscape across the planet.

The future could be a very exciting time for social scientists. However, the future poses a huge challenge, too. This is because social science should be able to contribute to decisions about social change. Theory and research should at least be used to move us away from potentially dreary, deadly, psychologically unhealthy futures and enlighten us about the many much more favorable possibilities. In theory, this process works when social scientists have at hand strong, well-supported theories and validated models useful to support policy making. Unfortunately, very often social scientists find themselves simply just trying to understand the rapidly changing (highly induced by technological change) social context. Erring on the side of caution, many social scientists may be reluctant to weigh in on policy discussions until enough good data have been collected to support or reject their basketful of theories.

Regrettably, this approach is not very useful in a rapidly changing world. Social science nearly becomes a branch of history with this approach in this setting. Social scientists will have to become much more proactive in their approach to their craft. They will have to anticipate change, and not just document, interpret, and then theorize about change. They will have to use the very tools promoting change, namely, computers, to accomplish this task. In addition to collecting prodigious amounts of data, social scientists will have to develop much more sophisticated social simulation models (e.g., Brent and Thompson, 1999; Moretti, 2002; Sallach, 2003), much like those that have revolutionized climatology and the research of global climate change. These models, if well developed, could help us understand the implications of new technologies on economies, politics, and individuals. The tools could foster proactive social science and policy making.

Of course, it is inadvisable for social scientists to abandon theory building and evaluation in a rush to build social simulation models. However, theory building, and especially evaluation, needs to be conceptualized in broader terms, and, ironically, in much longer timeframes. The explosion of new cultures and economic and political systems needs to be viewed as an opportunity for learning (Tonn, 1999). Instead of a relatively few “social experiments” being implemented at any one point in time, many will be implemented. If one believes that learning is accelerated by trial and error, then this increased number of experiments may prove beneficial to the long-term survival of humans on this planet – certainly if one believes that we have much to learn about how to organize ourselves socially, politically and economically. Social scientists need to monitor these “experiments” over long periods of time – decades, if not centuries – to assess their strengths and weaknesses. New knowledge will feed back into the simulation models, whose builders will probably struggle to model new social organizations

never before documented. Thus, I can foresee a monumental, long-term challenge for social scientists worldwide.

To conclude this chapter, changes in the culture and communities could have some more near-term impacts on social science analyses. The impacts would not be on social science methods, such as data collection and statistical methods, but on the reliance of old standby concepts and variables used in social science analyses. For example, social scientists routinely use variables such as these in their analyses: age, sex, income, education, race and ethnicity, marital status, number of children, household type, political affiliation, and religious affiliation. Use of these variables represents the explicit belief that these aspects of individuals' identities are key to understanding their behavior. A question that can be asked, given the preceding discussions, is whether these variables (i.e., identifiers) will be useful or useless in the future?

One can argue that many of these identifiers will become almost useless. For example, what would the variable "income" capture in a world dominated by technologically facilitated self-sufficiency? Maybe that variable would need to be replaced by one that measures the degree of a household's self-sufficiency from a wage-oriented way of life? Race may be much less important than whether someone has chosen genetic modification or was born with parentally determined genetic modifications. Ethnicity may give way to the identification of the new cultures emanating from Home Dwellers, Islandians, and Jetsons, for example. Technologist or Luddite may be a useful dichotomous variable in the future. Age, with advances in medical science, may become less useful than a variable that describes the current life roles the person is playing (i.e., parent, significant other) – roles that do not have to be as linearly ordered during a longer life span as they are for a shorter life span. The range of possible household types may expand significantly if virtual households (which represent very tight bonds between people who are in constant computer-mediated contact but live separately) and new forms of extended households in Islandian communities are considered. Political affiliations will become more complex if they cannot be simply assumed based on the latitude and longitude of one's place of residence. Number of children to have may become a more complex issue if it is important to distinguish between those born naturally from those receiving genetic enhancements. As mentioned in the previous section, sexual identity may become an even more important variable in social behavior, even if sex roles change in the new cultures, making traditional assumptions about this variable more complex.

### Concluding Thoughts

It is important to ask whether the convergence of technologies envisioned above will actually lead to fundamental changes in society that will require the determined coevolution of social science. For example, is it reasonable to assume that the private sector will develop energy, bio-, information, and nano-technologies that will result in the ultimate decrease in the size of the private sector? Will current political entities willingly give up power to allow the establishment of non-spatial governments, which will not be easy to implement practically? Can cultural inertia and social memes communicated down through generations be so easily overcome by the convergence of technologies? Will the powerful manage to manipulate the trends noted above to their own advantage? If social scientists are able to develop new paradigms, theories, and models in advance of technological and social change, will anyone listen to any advice they may have to offer?

Of course, the answers to these questions are unknown at this time. However, if technologies are changing as fast as most believe, and if the convergence of technologies will have extraordinarily powerful impacts on society, then even the most determined power bases, be they the capitalists of the private sector or leaders of existing governments, may be unable to defend their own interests against the onslaught of change. If society passes through the Singularity, the world will be different on the other side. It is likely that those people ready for change will benefit the most; those resisting change will be swept aside.

### References

- Abramson, J. 1998. The Internet and community. *Annual Review of the Institute of Information Studies*. Nashville, Tenn.: Institute for Information Studies.
- Bell, J. J. 2003. The singularity. *The Futurist* 37(3).
- Bostrom, A. 2003. Future risk communication. *Futures*, 35: 553–573.
- Brent, E., and G. A. Thompson, G. A. 1999. Sociology: Modeling social interaction with autonomous agents. *Social Science Computer Review* 17(3): 313–322.
- Castells, M. 1997. *The Information Age: Economy, Society and Culture, Vol. I. The Rise of the Network Society*. Malden, Mass.: Blackwell.
- Cote, J., and C. Levine. 2002. *Identify, Formation, Agency, and Culture: A Social Psychological Synthesis*. Mahwah, N.J.: Lawrence Erlbaum Associates.
- Crawford, R. 1996. Cosmetic nanosurgery. Pp. 61–80 in B. Crandall (ed.) *Nanotechnology: Molecular Speculations on Global Abundance*. Cambridge, Mass.: MIT Press.
- Curry, M. 1999. On the possibility of democracy in a geocoded world. *Social Science Computer Review* 17(1): 10–15.
- Daly, H. 1996. *Beyond Growth: The Economics of Sustainable Development*. Boston: Beacon Press.

- Davis, S., and C. Meyer. 1998. *Blur: The Speed of Change in the Connected Economy*. New York: Warner Books.
- Dyson, F. 1999. *The Sun, The Genome, and The Internet*. Oxford, England: Oxford University Press.
- Frankel, M., and A. Teich, A. 1994. *The Genetic Frontier: Ethics, Law and Policy*. Washington, D.C.: American Association for the Advancement of Science.
- Gleick, J. 1999. *Faster: The Acceleration of Just About Everything*. New York: Pantheon Books.
- Gray, C. 2001. *Cyborg Citizen: Politics in the Posthuman Age*. New York: Routledge.
- Hallpike, C. 1986. *The Principles of Social Evolution*. Oxford: Clarendon Press.
- Hart, M. 1999. *Guide to Sustainable Community Indicators*. North Andover, Mass.: Hart Environmental Data.
- Hawken, P., A. Lovins, and H. Lovins. 1999. *Natural Capitalism: Creating the Next Industrial Revolution*. Boston: Little, Brown and Company.
- Henderson, H. 1996. *Building a Win-Win World: Life Beyond Economic Warfare*. San Francisco: Berrett-Koehler Publishers.
- Huntington, S. P. 1996. *The Clash of Civilizations and the Remaking of World Order*. New York: Simon and Schuster.
- Jung, C. G. 1959. The archetypes and the collective unconscious. In H. Read, M. Fordham, and G. Adler (eds.) *Collected Works* (Vol. 9). Princeton, N.J.: Princeton University Press.
- Kakabadse, A., N. Kakabadse, and A. Kouzmin. 2003. Reinventing the Democratic Governance Project through information technology. *Public Administration Review* 63(1): 44–60.
- Kamarck, E., and J. Nye, J. (eds.). 1999. *democracy.com? Governance in a Networked World*. Hollis, N.H.: Hollis Publishing Company.
- King, A. 2001. Affective dimensions of Internet culture. *Social Science Computer Review* 19(4): 414–430.
- Kurzweil, R. 1999. *The Age of Spiritual Machines: When Computers Exceed Human Intelligence*. New York: Penguin Books.
- Longan, M. 2002. Building a global sense of place: The community networking movement in the United States. *Urban Geography* 23(3): 213–236.
- MacGregor, D. 2003. Psychology, meaning and the challenges of longevity. *Futures* 35: 575–588.
- Maslow, A. 1970. *Motivation and Personality*. New York: Harper and Row.
- McClelland, D. 1961. *The Achieving Society*. Princeton, N.J.: Van Nostrand.
- Moretti, S. 2002. Computer simulation in sociology: What contribution? *Social Science Computer Review* 20(1): 43–57.
- Mumford, L. 1961. *The City in History: Its Origins, Its Transformations, and Its Prospects*. New York: Harcourt, Brace and World.
- Murdock, G. 1945. The common denominator of cultures. In R. Linton (ed.), *The Science of Man in the World Crisis*. New York: Columbia University Press.
- Nye, J. 1999. Information technology and democratic governance. Pp. 1–18 in E. Kamarck and J. Nye (eds.), *democracy.com? Governance in a Networked World*. Hollis, N.H.: Hollis Publishing Company.
- Putnam, R. 2000. *Bowling Alone: The Collapse and Revival of the American Community*. New York: Simon and Schuster.



- Rheingold, H. 2000. *The Virtual Community: Homesteading the Electronic Frontier*. Cambridge, Mass.: MIT Press.
- Roco, M. C., and W. S. Bainbridge (eds.). 2001. *Societal Implications of Nanoscience and Nanotechnology*. Dordrecht, Netherlands: Kluwer.
- Rogers, C. 1959. A theory of therapy, personality, and interpersonal relationships, as developed in the client-centered framework. Pp. 184–256 in S. Koch (ed.), *Psychology: A Study of Science*, Vol. 3. New York: McGraw-Hill.
- Sagoff, M. 1988. *The Economy of the Earth: Philosophy, Law and the Environment*. New York: Cambridge University Press.
- Sallach, D. 2003. Social theory and agent architectures. *Social Science Computer Review* 21(2): 179–195.
- Silver, L. 1997. *Remaking Eden*. New York: Avon Books.
- Stewart, J., and R. Williams. 1998. The coevolution of society and multimedia technology. *Social Science Computer Review* 16(3): 268–282.
- Thompson, D. 1999. James Madison on cyberdemocracy. Pp. 35–42 in E. Kamarck and J. Nye (eds.), *democracy.com? Governance in a Networked World*. Hollis, N.H.: Hollis Publishing Company.
- Tonn, B. 2002. Anytown USA in the year 2050: Glimpses of the future. *Planning Forum* 8: 79–95.
- Tonn, B. 1999. Sociodiversity: Learning to make sustainability decisions. *Futures Research Quarterly* 15(2): 53–74.
- Tonn, B. 1996. A design for future-oriented government. *Future* 28(5): 413–431.
- Tonn, B., and D. Feldman. 1995. Non-spatial government. *Future* 27(1): 11–36.
- Wackernagel, M., and W. Rees. 1996. *Our Ecological Footprint: Reducing Human Impact on the Earth*. Gabriola Island, BC: New Society Publishers.
- Weinberger, D. 2002. *Small Pieces Loosely Joined: A Unified Theory of the Web*. Cambridge, Mass.: Perseus Books.
- Wright, A. T. 1942. *Islandia*. New York: Farrar and Rinehart.

## **APPENDIX 1: SURVEY OF NBIC APPLICATIONS**

*William Sims Bainbridge, National Science Foundation*<sup>1</sup>

*Abstract:* This appendix tabulates 76 predicted applications of converging technologies, based on input from authors and presenters who participated in the first three NBIC conferences.

### **Introduction**

The three book-length *Converging Technologies* reports that have been published to date have identified a very large number of potentially valuable applications that reasonably might result from the unification of various fields of science and engineering. Here we will list 76 of the most frequently mentioned breakthrough applications, of varying degrees of specificity and covering most areas of human life.

In order to give structure to this analysis, we consulted with 26 of the contributors to these reports, asking them to estimate when each application might be achieved and collecting their judgments of how beneficial each might be. Naturally, we could not expect them to predict accurately when any of these forecasts about technological convergence might be fulfilled, but this was a convenient way to capture their professional judgment of how far we have to go to achieve the particular goal. We often talk about near-term benefits versus long-term benefits of technological convergence, but which ones can in fact be anticipated relatively soon?

The contributors' judgments of how beneficial the applications might be are, of course, based on a combination of their professional expertise and their personal values, so they are not entirely objective. However, these evaluations provide a starting point for debates on the benefits of technological convergence, and therefore will be reported here as well.

### **Twenty Representative Applications**

The overview of the original *converging technologies* report listed 20 of these potential applications (Roco and Bainbridge, 2003: 5–6). They are arranged below in terms of what year the 26 contributors thought the breakthrough would be substantially achieved, based on the median of their individual judgments, because the median is not sensitive to extreme responses such as the rare cases in which someone felt the application would

---

<sup>1</sup> Any opinions, findings, and conclusions or recommendations expressed here are those of the author and do not necessarily reflect the views of NSF.

“never” be achieved. The mean ratings of benefit are given in parentheses on a 0 to 10 scale.

### *2015*

1. Anywhere in the world, an individual will have instantaneous access to needed information, whether practical or scientific in nature, in a form tailored for most effective use by the particular individual. (8.3)

2. New organizational structures and management principles based on fast, reliable communication of needed information will vastly increase the effectiveness of administrators in business, education, and government. (8.0)

3. Comfortable, wearable sensors and computers will enhance every person’s awareness of his or her health condition, environment, chemical pollutants, potential hazards, and information of interest about local businesses, natural resources, and the like. (8.7)

### *2020*

4. People from all backgrounds and of all ranges of ability will learn valuable new knowledge and skills more reliably and quickly, whether in school, on the job, or at home. (8.4)

5. Individuals and teams will be able to communicate and cooperate profitably across traditional barriers of culture, language, distance, and professional specialization, thus greatly increasing the effectiveness of groups, organizations, and multinational partnerships. (8.8)

6. National security will be greatly strengthened by lightweight, information-rich war fighting systems, capable uninhabited combat vehicles, adaptable smart materials, invulnerable data networks, superior intelligence-gathering systems, and effective measures against biological, chemical, radiological, and nuclear attacks. (5.5)

7. Engineers, artists, architects, and designers will experience tremendously expanded creative abilities, both with a variety of new tools and through improved understanding of the wellsprings of human creativity. (8.3)

8. Average persons, as well as policymakers, will have a vastly improved awareness of the cognitive, social, and biological forces operating their lives, enabling far better adjustment, creativity, and daily decision making. (8.3)

9. Factories of tomorrow will be organized around converging technologies and increased human-machine capabilities as intelligent environments that achieve the maximum benefits of both mass production and custom design. (7.8)

10. Agriculture and the food industry will greatly increase yields and reduce spoilage through networks of cheap, smart sensors that constantly monitor the condition and needs of plants, animals, and farm products. (8.7)

11. The work of scientists will be revolutionized by importing approaches pioneered in other sciences, for example, genetic research employing principles from natural language processing and cultural research employing principles from genetics. (8.5)

*2025*

12. Robots and software agents will be far more useful for human beings, because they will operate on principles compatible with human goals, awareness, and personality. (7.2)

13. The human body will be more durable, healthier, more energetic, easier to repair, and more resistant to many kinds of stress, biological threats, and aging processes. (8.5)

14. A combination of technologies and treatments will compensate for many physical and mental disabilities and will eradicate altogether some handicaps that have plagued the lives of millions of people. (8.6)

*2030*

15. Fast, broadband interfaces between the human brain and machines will transform work in factories, control automobiles, ensure military superiority, and enable new sports, art forms and modes of interaction between people. (6.4)

16. Machines and structures of all kinds, from homes to aircraft, will be constructed of materials that have exactly the desired properties, including the ability to adapt to changing situations, high energy efficiency, and environmental friendliness. (8.9)

17. The ability to control the genetics of humans, animals, and agricultural plants will greatly benefit human welfare; widespread consensus about ethical, legal, and moral issues will be built in the process. (6.2)

18. Transportation will be safe, cheap, and fast, due to ubiquitous real-time information systems, extremely high-efficiency vehicle designs, and the use of synthetic materials and machines fabricated from the nanoscale for optimum performance. (8.3)

19. Formal education will be transformed by a unified but diverse curriculum based on a comprehensive, hierarchical intellectual paradigm for understanding the architecture of the physical world from the nanoscale through the cosmic scale. (7.5)

2050

20. The vast promise of outer space will finally be realized by means of efficient launch vehicles, robotic construction of extraterrestrial bases, and profitable exploitation of the resources of the Moon, Mars, or near-Earth approaching asteroids. (6.7)

### **An Additional 50 Applications**

The following 50 ideas about future applications of converging technologies were culled from the three reports.

2010

1. New, realistic training environments will revolutionize training of military personnel, such as virtual-reality battlefields and war-gaming simulations. (6.2)

2. Warfighters in stressful situations will benefit from much better information, connectivity, and risk reduction. (6.3)

2015

3. Radically new methods will enhance small-scale design activities by individuals in such fields as commercial art, entertainment, architecture, and product innovation. (7.9)

4. Smart clothing and fashion accessories will process information about the environment, such as data about things in the spatial vicinity, ambient temperature, humidity, pollution, and ultraviolet radiation levels. (7.7)

5. Computer interface architectures will be changed so that disabled groups (e.g., blind, sight impaired, dyslexic, arthritic, immobile people) can access the Internet and other information sources as transparently and quickly as other people. (8.8)

6. Free availability of information to disadvantaged people around the world will improve their agricultural production, health, nutrition, and economic status. (8.6)

7. Human biochemistry will be modified to give soldiers and combat pilots greater endurance for sleep deprivation, enhanced physical and psychological performance, and enhanced survivability from physical injury. (5.5)

2020

8. Uninhabited combat aircraft will launch, navigate, identify targets, evade threats, and return to base autonomously, requiring commands from humans only to fire weapons. (5.5)

9. Personal sensory device interfaces will provide people with valuable data about their social and physical environments, such as increased awareness of the chemical composition of things, food ingredients, and biohazards. (8.2)

10. Wholly new industrial design methods will pay great dividends, including biologically inspired and evolutionary design approaches. (8.1)

11. Reliable and secure communication networks will be self-configuring, self-protecting, and self-monitoring. (8.4)

12. Extremely efficient research tools will extract previously unknown biological information from DNA, proteins, cells, tissues, organisms, and society as a whole. (8.4)

13. Sensory replacement, for example communicating visual information by means of sounds or substituting touch for hearing, will be useful in the lives of disabled people. (8.4)

14. There will be entirely new categories of materials, devices, and systems for use in manufacturing, construction, transportation, medicine, emerging technologies and scientific research. (8.4)

15. National security will be supported by miniaturized, affordable sensor suites that provide information from previously inaccessible areas, that is processed in real-time and immediately distributed to the defense or intelligence personnel who need it. (6.5)

16. Microfabricated sensor systems will provide ample, affordable, error-free forewarning of chemical, biological, radiological, or explosive military and terrorist threats. (8.3)

17. Communication and information systems will automatically learn and adapt, based upon an understanding of human behavior. (7.6)

2025

18. Sophisticated monitoring of brain activity and biofeedback techniques will facilitate education by assessing students' learning strengths and improving their attention. (7.3)

19. A new services science discipline will emerge, based on knowledge and skills at the intersection of existing disciplines, with the ability to increase the probability of success of complex service industries and to improve organizational management in general. (7.5)

20. Many people will carry with them a highly personalized computer database system that understands the user's emotions and functions as an

artificial intelligence advisor to help the person understand their own feelings and decision options. (7.0)

21. A deep understanding of visual language – communication by pictures, icons, and diagrams – will permit more effective interdisciplinary communication, more complex thinking, and breakthroughs in education. (8.5)

22. Sociable technology will enhance human emotional as well as cognitive performance, giving us more satisfactory relationships not only with our machines but also with each other. (6.7)

23. Convergence of technologies will be so central to social change that it will transform the law and legal institutions, as various legal specialties merge, new ones emerge, and new issues challenge courts and legislatures. (6.5)

*2030*

24. Computer-generated virtual environments will be so well tailored to the human senses that people will be as comfortable in virtual reality as in reality itself. (5.4)

25. Devices connected directly to the nervous system will significantly enhance human sensory, motor, and cognitive performance. (6.8)

26. We will have the technical means to ensure an adequate food supply, clean air, and clean water. (9.2)

27. Aircraft will constantly change the shapes of their wings and other surfaces, to optimize efficiency and control throughout take-off, cruise, maneuvering, landing, transonic and high-altitude flight. (8.0)

28. A fresh scientific approach to culture, based on concepts from evolutionary biology and classification techniques from information science, will greatly facilitate humanities scholarship, marketing of music or literature, and artistic innovation. (6.8)

29. The unification of the sciences will provide a knowledge base and cross-disciplinary concepts that will radically transform science and engineering education. (8.4)

30. Neuroceuticals – non-addictive neurochemical brain modulators with high efficacy and negligible side effects – will cure mental illness and expand artistic expression. (7.0)

31. Interaction between humans and computers will be optimized, with interfaces designed on the basis of an understanding of how the human mind and senses really function. (8.0)

2035

32. Three-dimensional printers will be widely used not only for rapid prototyping but also for economical, local, on demand manufacture of art objects, machine parts, and a host of other things from a variety of materials. (8.2)

33. It will be technically and economically possible to sequence the genetic code of each unique individual, so we will fully understand genetic variations in human performance. (6.6)

34. Nano-enabled sensors, implanted inside the human body, will monitor metabolism and health, diagnosing any health problem before the person even notices the first symptom. (8.3)

35. Assistive technologies will largely overcome disabilities such as blindness, deafness, and immobility. (8.8)

2040

36. Humane machines will adapt to and reflect the communication styles, social context, and personal needs of the people who use them. (6.9)

37. A combination of techniques will largely nullify the constraints associated with a human's inherent ability to assimilate information. (6.6)

38. Science will achieve great progress in understanding and predicting the behavior of complex systems, at multiple scales and between the system and the environment. (8.4)

39. A new form of computing will emerge in which there is no distinction between hardware and software, and in which biological processes calculate the behavior of complex, adaptive systems. (7.3)

40. Nanoscale molecular motors will be mass produced to perform a variety of tasks, in fields as diverse as materials manufacturing and medical treatment. (7.5)

2045

41. Warfighters will have the ability to control vehicles, weapons, and other combat systems instantly, merely by thinking the commands or even before fully forming the commands in their minds. (4.5)

2050

42. New research tools will chart the structure and functions of the human mind, including a complete mapping of the connections in the human brain. (7.8)



43. Molecular machines will solve a wide range of problems on a global scale. (7.5)

44. Memory enhancement will improve human cognition, by such means as external electronic storage and infusion of nerve growth factors into the brain. (6.9)

45. A predictive science of the behavior of societies will allow us to understand a wide range of socially disruptive events and allow us to put mitigating or preventive strategies in place before the harm occurs. (6.7)

46. A nano-bio processor will be developed that can cheaply manufacture a variety of medicines that are tailored to the genetic makeup and health needs of an individual. (8.4)

47. Nanorobots will perform surgery and administer treatments deep inside the human body, achieving great health benefits at minimum risk. (8.1)

*2070*

48. Scientists will be able to understand and describe human intentions, beliefs, desires, feelings and motives in terms of well-defined computational processes. (5.1)

49. Rather than stereotyping some people as disabled, or praising others as talented, society will grant everybody the right to decide for themselves what abilities they want to have. (6.0)

*2085*

50. The computing power and scientific knowledge will exist to build machines that are functionally equivalent to the human brain. (5.6)

### **Six Very General Application Areas**

The first two Converging Technologies reports categorized applications in terms of six very general areas (Roco and Bainbridge, 2003:-xi; Roco, 2004: 7). We would expect judgments about such very broad categories to be less precise, but nonetheless the following temporal ordering offers food for thought.

*2020*

1. Technological convergence will greatly strengthen national security. (7.2)

2025

2. Technological convergence will greatly improve human health and physical capabilities. (8.4)

3. Technological convergence will greatly unify science and education. (8.3)

4. Technological convergence will greatly reshape business and organizations. (7.8)

2030

5. Technological convergence will greatly expand human cognition and communication. (7.8)

2050

6. Technological convergence will greatly enhance group and societal outcomes. (7.0)

## References

Roco, M. C. 2004. Science and technology integration for increased human potential and societal outcomes. Pp. 1–16 in Mihail C. Roco and Carlo D. Montemagno (eds.), *The Coevolution of Human Potential and Converging Technologies*. New York: New York Academy of Sciences.

Roco, M. C., and W. S. Bainbridge (eds.). 2003. *Converging Technologies for Improving Human Performance*. Dordrecht, Netherlands: Kluwer.

## APPENDIX 2: INFORMATION TECHNOLOGY FOR CONVERGENCE

*William Sims Bainbridge, National Science Foundation*<sup>1</sup>

*Abstract:* This appendix categorizes 96 convergent, National Science Foundation–funded information technology research projects into 12 categories: computational nanoscience, nanocomputing, quantum monotecnology, sensors, nanoscale bioinformatics, biotechnology, biocomputing, computational neuroscience, cognitive technologies, educational technologies, human–technology interaction, and transforming tools.

### Introduction

Converging Technologies was originally conceptualized as a potential successor to the National Nanotechnology Initiative (NNI), but it is also a potential successor to the Information Technology Research (ITR) initiative. ITR included a 5-year annual Foundation-wide grant competition of the National Science Foundation (NSF) that ran from fiscal year 2000 through fiscal year 2004 and ended September 30, 2004, plus other related efforts that continue into subsequent years. Because the last of the awards of the original 5-year central competition have recently been announced, this is a good time to survey ITR and consider how it has contributed to technological convergence.

The distinctive quality of technological convergence at the dawn of the 21st century is its exploitation of the unity of nature at the nanoscale. For the first time, scientists and engineers have a diverse and powerful set of tools for understanding phenomena at the nanoscale and designing radically new materials, structures and devices that are wholly or in part smaller than the micron scale. Thus, most of the research projects to be discussed below depend upon or have significant implications for nanoscience and nanotechnology. In addition, of course, some significant forms of convergence are taking place between sciences and technologies that have not yet become integrated with nanoscale activities, so we will mention some projects in this category as well. Notably, we will examine a small number of projects that promise to create new cognitive technologies based on convergence between cognitive science and information technology, supported (when the current state of development makes it possible) by biotechnology and nanotechnology.

---

<sup>1</sup> Any opinions, findings, and conclusions or recommendations expressed here are those of the author and do not necessarily reflect the views of NSF.

An appendix in the second *Converging Technologies* report described eight ITR projects that illustrated the early steps of scientific and technological unification, so detailed information about them will not be repeated here.<sup>1</sup> Four of the eight projects directly concerned nanotechnology. The fifth involved brain images, and thus applied information technology to the intersection of biotechnology and cognitive science. Two others combined information technology and cognitive science for medical education and for research about environmental influences on health. The final project employed cognitive science and information technology to achieve goals in nanoscale biotechnology.

It is important to emphasize that we are still in the very earliest stages of scientific and technological convergence. Therefore, at best, projects tend to connect one small corner of one field with an adjacent small corner of another. As the expression goes, many of these projects are harvesting “the low-hanging fruit” – accomplishing valuable goals that happen to be somewhat obvious and relatively easy. To achieve substantial convergence we will need radically new tools, including scientific concepts, analytical techniques, measurement instrumentation, and fabrication methodologies. Thus, although the projects described below are exciting and aim for worthy goals, they pale in comparison with the work that will be possible when full convergence take place. These research studies sketch the general contours of what might be accomplished over the next decade, but progress will not happen automatically, and we will need to invest in a diverse array of enabling tools and demonstration efforts.

Following are very brief descriptions of 96 ITR projects – 8 in each of 12 categories – that promoted a significant degree of scientific and technological convergence. For each, data provided include the title, seven-digit NSF award number, principal investigator name, and the institution to which the grant was awarded. The information presented here is largely based on the abstracts of the NSF awards, available from the NSF Web site, which are in the public domain and freely available for anyone to read. Additional information is often available from the academic Web sites of the principal investigators. Direct quotations from the abstracts are given in quotation marks.

### **Computational Nanoscience**

At a first approximation, computational nanoscience follows one or both of two distinct approaches: 1) computer simulation to model the behavior of nanoscale structures, and 2) nanoinformatics of dynamic databases to store, manage, and retrieve information relevant to nanoscience and

---

<sup>1</sup> NSF awards 0205523, 0135946, 0218142, 0205178, 0312226, 0313237, and 0219025 plus collaborative awards 0225656, 0225636, 0225609, and 0225607.

nanotechnology. At present, nanoinformatics is not well developed, and our best picture of its future potential can probably be gained by considering nanoscale bioinformatics, which is covered in a later section.

1. “Science and Software for Predictive Simulation of Chemo-Mechanical Phenomena in Real Materials” (0325553, Rodney Bartlett, University of Florida). The goal of this work is predictive, chemically accurate computer simulations of phenomena such as “the effect of water on the properties of a silica nanorod and electron transport in nanostructures.”

2. “Physics-Based Modeling of Plastic Flow that Couples Atomistics of Unit Processes with Macroscopic Simulations” (0219243 John Bassani, University of Pennsylvania). This research develops multiscale computational models of “the deformation behavior of metallic materials possessing complex – non-planar – dislocation core structures,” and “a rigorous methodology to link theories at scales ranging from electronic and atomic through mesoscale and macroscopic” that will relate to problems in nanotechnology.

3. “Collaborative Research on Large-Scale Dislocation Dynamics Simulations for Computational Design of Semiconductor Thin Film Systems” (0113172, Lizhi Sun, University of Iowa; 0113555, Nasr Ghoniem, University of California–Los Angeles). Computer simulation explores processes of deformation, dislocation, and failure of nanoscale engineered structures to enable optimization of engineering designs.

4. “Novel Hybrid (Discrete/Continuous) Computational Models for Very High Dimensional Nonlinear Dynamical Systems: From the Molecular to the Continuum Scale” (0218601, Earl Dowell, Duke University). The goal of this project is to “develop computational models of complex nonlinear dynamical systems that are often encountered in nanoscale phenomena and devices,” seeking to find ways of simplifying models marked by high dimensionality without significant loss of information.

5. “Study of Complex Nanoclustered States using Novel Efficient Algorithms” (0312333 and 0443144, Adriana Moreo, Florida State University and University of Tennessee, Knoxville). This work develops methods for simulating the spontaneous generation of nanoclusters, such as “high temperature superconductors, colossal magnetoresistive manganites, and dilute magnetic semiconductors.”

6. “An Integrated Algorithm for Heat Conduction from Nano- to Macroscale” (0128365, Jonathan Freund, University of Illinois at Urbana-Champaign; 0129088, Gang Chen, Massachusetts Institute

of Technology). A simulation tool was programmed to improve engineering of microscale devices with nanoscale components by modeling heat conduction, which involved not merely thermal radiation but also phonons (quantized modes of vibration) that become significant media for transmitting heat at the nanoscale in ways that defy traditional methods of analysis.

7. “Novel Scalable Simulations Techniques for Chemistry, Materials Science and Biology” (0121357, Josep Torrellas, University of Illinois at Urbana-Champaign; 0121432, Roberto Car, Princeton University; 0121302 & 0229959, Michael Klein, University of Pennsylvania; 0121273, Nicholas Nystrom, Carnegie-Mellon University; 0121375, Mark Tuckerman, New York University; 0121367, Glenn Martyna, Indiana University). A multiinstitution team involving materials science and biochemistry develops accurate new methods for “atom-based simulations of key processes in chemistry, nanoscience and engineering, and biology.” The results of this work “can potentially impact the design of polymer-generating catalysts, nanoscale electronic devices, and artificial biomimetic catalysts.”

8. “Enabling Microscopic Simulators To Perform System-Level Analysis” (0205484, Yannis Kevrekidis, Princeton University; 0205584, Dimitrios Maroudas, University of California at Santa Barbara; 0205411, Robert Armstrong, Massachusetts Institute of Technology; 0205201, Mark T. Swihart, State University of New York at Buffalo). The goals of this collaborative effort are to advance microelectronics, bioinformatics, and nanotechnology by developing computational methods to analyze and describe materials at the large scale of engineered systems, based on information about the structure and behavior of the materials at the molecular scale.

### **Nanocomputing**

As the microelectronic hardware that is the basis of modern computing has become ever smaller, it has moved down into the nanoscale. For example, the smallest transistor components on computer chips are now about 50 nanometers across. Small size implies less waste of power but greater speed, and it has perhaps fortuitously been associated with lower costs. To sustain progress with information technology, essential for the well-being of civilization, requires a broad range of scientific research projects establishing the basis for radical new kinds of nanoelectronics. At the same time, researchers are exploring the virtues of carbon nanotubes as replacements for silicon-based transistors and investigating other approaches to molecular computing.

1. “Nanoarchitecture: Balancing Regularity, Complexity, and Defect Tolerance using DNA for Nanoelectronic Integration” (0326157, Alvin Lebeck, Duke University). This project explores the possibility of using DNA “to self-assemble well-defined nanoscale building blocks into functional nanoelectronic structures”; for example, putting together inorganic fragmented carbon nanotubes to form nanoscale computing circuitry.

2. “Post-Silicon Validation and Diagnosis Based Upon Statistical Delay Models” (0312701, Li-Chung Wang, University of California at Santa Barbara). Reliable functioning of computer components requires precise timing of the behavior of the component, but nanoscale components will be especially vulnerable to “process variations, small defects, and electrical noise,” so this project is developing new statistical methods to simulate timing behavior and thereby “resolve the inconsistency between a design model and its implementation.”

3. “Optical Control in Semiconductors for Spintronics and Quantum Information Processing” (0325474, Junichiro Kono, Rice University; 0325499, Christopher Stanton, University of Florida; 0325599, Lu Sham, University of California at San Diego). This collaborative research aims to “develop ultrafast optical methods for controlling electronic, magnetic, vibrational, and excitonic properties of semiconductors for fast information processing.” This work demonstrates ultrafast manipulation of ferromagnetism, proposes a method for controlling spin by exploiting indirect exchange that couples magnetic moments of electrons over relatively large distances, and carries out studies of coherent phonons in magnetic films.

4. “Theory of Nanomagnets” (0310517, Eugene Chudnovsky, CUNY Herbert H Lehman College). “Molecular nanomagnets and nanoparticles represent the ultimate limit of miniaturization of magnetic memory units,” so this research addresses both fundamental scientific questions about magnetism at the nanoscale and “questions about applications of nanomagnets for the information technology of the future.”

5. “Simulations and Modeling of Carbon Nanotubes” (0113574, Mark Jarrell, University of Cincinnati). Building electronic devices at the nanoscale, rather than the microscale, can increase their speed by a factor of as much as 1000, thus facilitating the flow of information. The research addresses several of the challenges related to achieving this goal, such as strongly correlated electrons in carbon nanotubes, temperature-dependent properties including superconductivity, and the effects of disorder.

6. “Methodologies for Robust Design of Information Systems under Multiple Sources of Uncertainty” (0205227, David Blaauw, University of Michigan – Ann Arbor). As microelectronic components become progressively smaller and enter the nanoscale, manufacturing tolerances become acute and interference between components increases, so that reliability and predictability present serious problems. This research will develop stochastic models of the performance of electronic components in the nanometer-regime as a function of a variety of sources of uncertainty.

7. “Institute for the Theory of Advanced Materials in Information Technology” (0325218, James Chelikowsky, University of Minnesota at Twin Cities). “The Institute will provide a focal point in the community for the creation of new knowledge and computational tools for advanced electronic materials” including “organic and plastic semiconductors, low-k dielectrics, dilute magnetic semiconductors and spintronic devices, carbon nanotubes, and nanowires.”

8. “Center for Bits and Atoms” (0122419, Neil Gershenfeld, Massachusetts Institute of Technology). The goal of this center is to “study the content of information and its physical properties, on length scales from atomic nuclei to global networks,” achievable in part by exploring alternatives to conventional computer chips, such as “nanocrystalline electronically-active inks,” and by approaching the work from a perspective that considers information and matter to be complementary.

### **Quantum Nanotechnology**

At the lower end of the nanoscale, quantum effects begin to become significant. Although some forms of quantum computing involve processes that take place below the nanoscale, much of the research today seeks to exploit quantum effects in nanoscale structures, such as quantum dots, which may become fundamental components of future computing systems. At the same time, for some purposes, quantum effects can be a nuisance, for example, introducing noise into nanoelectronic circuits, that must be understood if it is to be managed successfully.

1. “Institute for Quantum Information” (0086038, John Preskill, California Institute of Technology). The institute is not only developing algorithms for quantum computing but also is developing theoretical models for coherent nanotechnology. An important part of the work explores how to suppress unwanted quantum effects in nanoscale electronic devices.



2. “Center for Modeling of Quantum Dynamics, Relaxation and Decoherence in Solid-State Physics for Information-Technology Applications” (0121146, Vladimir Privman, Clarkson University). Research on coherent quantum mechanical processes – such as spin relaxation dynamics and charge carrier transport – will contribute to nanometer-size computer components, including new measures and methods for reliability estimation of designs.

3. “Large-Scale Quantum Mechanical Molecular Dynamics Simulations” (0112824, Chakram Jayanthi, University of Louisville). This project applies computational methods to address questions in materials science concerning the properties of carbon nanorods, carbon multiwall nanotubes, and their contacts with metal electrodes.

4. “Modeling and Simulations of Quantum Phenomena in Semiconductor Structures of Reduced Dimensions” (0205328, Mei-Yin Chou, Georgia Institute of Technology). Computer simulations based on theoretical first principles determines growth, electronic, vibrational, and conductance characteristics of nanowires.

5. “Exploration and Control of Condensed Matter Qubits” (0205641, K. Birgitta Whaley, University of California at Berkeley). “This project explores the development of a new type of highly parallel processor that takes advantage of quantum degrees of freedom in solid state nanostructures to process information.” The research has focused on fabrication, measurement, and control of nanoscale logic gates that potentially could be the basis of new information technologies.

6. “Quantum Computing Using Electrons on Helium Films” (0085922, Arnold Dahm, Case Western Reserve University). “This project is a combined experimental and theoretical research effort to manufacture and investigate a system of interacting quantum bits (qubits) based on electrons on a helium film which covers an array of micro electrodes, and to develop methods for controlling this system.”

7. “Simulation Tools for Open Quantum Systems with Application to Molecular Electronics Systems” (0312105, Christopher Roland, North Carolina State University). This work is developing theory-based computer simulations “to calculate current-voltage characteristics of molecular and nanoscale structures with an aim to understand and predict transport and other properties of these systems” to strengthen the knowledge base for designing nanoscale computer hardware.

8. “Multiscale Quantum Simulations of Electron Transport in Molecular Devices” (0112322, Thomas Beck, University of Cincinnati). With the long-term goal of developing molecular

computing devices, this work will investigate “electron transport in synthetic organic molecules proposed as prototype molecular wires.”

### **Sensors**

An especially promising area of research and development is microscale sensors with nanoscale components, capable of detecting and identifying chemical hazards, nanoscale particles, and microorganisms. In addition, work at larger scales is developing new principles for integrating multimodal information from sensor arrays, in manners that potentially can later be applied at the nanoscale.

1. “Molecular Computation with Automated Microfluidic Sensors” (0121368, A. Paul Alivisatos, University of California at Berkeley; 0121405, Lydia Sohn and Laura F. Landweber, Princeton University; 0121074 Ronald Davis, Stanford University). This collaborative project develops technology to detect single biological molecules by means of nanoscale electronic sensors, with applications in molecular computing, DNA sequencing, and general biological research.

2. “Active Sensor Networks with Applications in Marine Microorganism Monitoring” (0121141, Aristides A. Requicha, University of Southern California). With the ultimate aim of monitoring microbes in the ocean or in water supplies, this project focuses on distributed nanorobots coordinated through networking, methods “to investigate the causal relationships between environmental conditions and micro-organisms,” and sensing techniques for identifying microorganisms.

3. “Wireless Networking Solutions for Smart Sensor Biomedical Applications” (0086020, Loren Schwiebert, Wayne State University). This project develops technology for “small biomedical devices composed of smart sensors that are implanted for long-term use,” that communicate with each other and with external equipment by means of radio, potentially valuable for future retinal and brain implants to overcome visual impairment, as well as for treatment of many diseases.

4. “Analysis of Complex Audio-Visual Events Using Spatially Distributed Sensors” (0205507, James Rehg, Georgia Institute of Technology). Meaningfully combining information from large numbers of widely distributed microphones and cameras is a daunting cognitive challenge, but many applications will benefit from effective representations and learning methods that facilitate self-calibration so that wearable sensing systems will function reliably.

5. “Fabrication of Reversible Microarray Sensors using Thermally Responsive Biopolymers” (0330451, Wilfred Chen, University of California at Riverside). The aim is “to develop a potentially reliable and economical technique for the fabrication of reversible microarray sensors” that could analyze enzymes, antibodies, proteins, or genetic material.

6. “The Computer Science of Biologically Embedded Systems” (0113679, Michael Black, Brown University). Using “mathematical and computational techniques from computer vision, image processing, and machine learning,” this project develops methods for designing sensors embedded in the brain to detect meaningful signals from neurons, with the ultimate goals of helping severely disabled people and understanding better how the neurons of the human brain encode information.

7. “Algorithms for Machine Perception based on Visual Cortex Models” (0082119, Irina Gorodnitsky, University of California – San Diego). Research, which employs scalp electrodes to monitor the behavior of the visual cortex of the human brain, seeks to provide an improved foundation for neuromorphic design of machine vision.

8. “Technologies for Sensor-based Wireless Networks of Toys for Smart Developmental Problem-solving Environments” (0085773, Mani Srivastava, University of California at Los Angeles). The rapidly advancing miniaturization of computing technologies now permits many ordinary household artifacts to become networked, including children’s toys designed to enhance the cognitive “developmental process by providing a problem-solving environment that is individualized, context adaptive, and coordinated among multiple children.”

### **Nanoscale Bioinformatics**

Determining the structure and behavior of nanoscale biological molecules, such as proteins, presents very difficult challenges for computer and information science. Successful approaches rely upon computation-intensive simulations, data analysis and manipulation techniques, and methods for visualizing dynamic structure. Bioinformatics is a broad field, including the comparison of species and study of large-scale organic and environmental systems, but many of its greatest challenges exist at the nanoscale.

1. “Subnanometer Structure Based Fold Determination of Biological Complexes” (0325004, Wah Chiu, Baylor College of Medicine; 0324645, Andrej Sali, University of California at San Francisco; 0325550, Chandrajit Bajaj, University of Texas at Austin). This multi-institution team is developing visualization and

computational methodologies for deducing the folded structure of large macromolecular complexes, which are the prime functional units of biology below the cellular level.

2. “Computational Techniques for Applied Bioinformatics” (0085801, Ming Li, University of California at Santa Barbara; 0085910, Tao Jiang, University of California at Riverside). This project in computational biology develops methods “to sequence data from the genomes of mitochondria, viruses, chloroplasts and bacteria” with the goal of understanding better the history and molecular processes involved in the evolution of plants.

3. “Constructing Protein Ontologies Using Text Mining” (0205470 Inderjeet Mani, Georgetown University). “An ontology is a semantic model that contains a shared vocabulary and classification of concepts in a domain.” Extremely useful as classification systems, ontologies often require impractical amounts of human labor to create, and this project develops an ontology of protein names largely automatically, through text mining of published databases.

4. “Next-Generation Bio-Molecular Imaging and Information Discovery” (0331697, Bangalore Manjunath, University of California – Santa Barbara; 0331657, Robert Murphy, Carnegie-Mellon University). This project develops methodologies needed to achieve “a full understanding of tens of thousands of proteins and the complex molecular processes they engage in,” through a new approach to imaging in which much information processing occurs in sensors having super-high resolution, feeding into an advanced pattern recognition system and building “a distributed database of bio-molecular images.”

5. “Enhancing Access to the Bibliome for Genomics” (0325160, William Hersh, Oregon Health and Science University). This project is improving genomic information retrieval systems by providing resources to evaluate retrieval capabilities in this domain.

6. “Feedback from Multi-Source Data Mining to Experimentation for Gene Network Discovery” (0325116, Raymond Mooney, University of Texas at Austin). This work applies data mining methods from computer science to biology, to discover regulatory gene networks in both humans and yeast cells to advance the goals of “determining the fundamental organization of genes in the cell and creating a theoretical framework for interpreting high-throughput biological data, moving ultimately towards predictive theoretical models of biology and understanding disease at the cellular level.”

7. “Best-First Search Algorithms for Sequence Alignment Problems in Computational Biology” (0113313, Richard Korf,

University of California at Los Angeles; 0113618, Weixiong Zhang, Washington University). Computer science research to develop the most efficient way of aligning gene sequences analytically between two different species not only would facilitate abstract genetics research but would also have the practical benefit, for example, of helping medical researchers understand how results of research on laboratory mice could be extrapolated to human beings.

8. “Machine Learning Approaches to Protein Sequence Comparison” (0312706, Christina Leslie, Columbia University). “Pairwise sequence comparison is a central problem in bioinformatics and genomics,” important in deducing the evolutionary relatedness of two organisms and in understanding the function of genes that they share, and this project seeks to develop new methods based on machine learning, that “will be broadly useful to biologists and bioinformaticians.”

## **Biotechnology**

At the nanoscale and above, technologies rooted in biology often rely upon information technology as a tool of the research process, in designing biotech applications, and in the control of production or use. Of all the areas of science-oriented information technology, perhaps the greatest current emphasis is upon bioinformatics, but other areas – such as nanoinformatics and cognoinformatics – are likely in the near future to imitate the successes achieved with biology.

1. “Interactive Software Systems for Expert-Assisted Image Analysis and Classification of Aquatic Particles” (0325937, Michael Sieracki, Bigelow Laboratory for Ocean Sciences; 0325167, Edward Riseman, University of Massachusetts at Amherst; 0325018, Mark Benfield, Louisiana State University and Agricultural and Mechanical College). This collaborative project combines information science methods, such as computer vision and machine learning, inspired by human perception and cognition to classify bacteria, plankton, and other microscopic particles in ocean water automatically.

2. “Automated Design of Very Large Scale Integrated Biofluidic Chips” (0325344, Tamal Mukherjee, Carnegie-Mellon University). This project “is developing algorithms, languages, models and methodologies for the design of biofluidic chips” used to analyze microscopic quantities of biological substances such as DNA.

3. “Mining the Bibliome – Information Extraction from the Biomedical Literature” (0205448, Aravind Joshi, University of Pennsylvania). This work develops “qualitatively better methods for

automatically extracting information from the biomedical literature,” to facilitate biomedical research on such topics as the genetic factors in cancer.

4. “Information Technology for Self-Assembling Synthetic Genes” (0326037, Richard Lathrop, University of California at Irvine). To overcome challenges in producing “a synthetic gene that encodes a protein of interest and is optimized for desirable sequence properties,” “this project is developing novel methods in information technology and biotechnology for the self-assembly of long strings of mixed coding, regulatory, and intergenic regions.”

5. “Optimal Support Set Selection in Data Analysis with Applications to Bioinformatics” (0312953, Peter Hammer, Rutgers University). Systems biology often involves simultaneous analysis of a very large number of biological attributes, and this project aims to develop computational methods for simplifying the problems without significantly reducing accuracy.

6. “Center for Computational Biophysics” (0225630, Herbert Levine, University of California at San Diego). Convergence of physics and biology permits new understanding and control of complex biological machines, such as the ribosomes within living cells and the calcium dynamics inside heart cells.

7. “Computational Design of Mixed-Technology Systems” (0121616, Narayana R. Aluru, University of Illinois at Urbana-Champaign). This project develops and evaluates new computational design tools for “Biological Microelectromechanical Systems (BioMEMS), Nanoelectromechanical Systems (NEMS) and Biological ion channels integrated with nanoelectronics (nanobioelectronics).”

8. “‘Regulography’ – Quantitative Reconstruction of Transcriptional Regulatory Networks” (0326605, James Liao, University of California at Los Angeles). A team uniting computer science, biochemistry, microbiology, and statistics is charting “the hidden structure and dynamics of transcriptional regulatory networks based on massive gene expression data (generated from DNA microarray) and regulatory models under the constraints of various ancillary information, such as protein interactions with DNA, other proteins, and RNA.”

## **Biocomputing**

Conceptually, there are two main ways in which biology can contribute to computing and information technology. First, complex biological processes, like those studied in genetics, can offer analogies that help computer scientists and electrical engineers design electronic systems based on new

principles. Second, biological substances and systems can be harnessed directly to carry out computations.

1. “Molecular Computation in Ciliates” (0121422, Laura Landweber, Princeton University). This work applies concepts from computer science to understand the way that microorganisms carry out a kind of information processing when ciliated protozoans sort out genes that have become scrambled in hopes not only of understanding genetic process better but also finding ways to build biological computers.

2. “A Twin-Framework to Analyze, Model and Design Robust, Complex Networks Using Biological and Computational Principles” (0205061, Animesh Ray, Keck Graduate Institute). This research studies how a particular microorganism regulates the synthesis of RNA molecules, in order to develop a biologically inspired model for large-scale information networks with applications in designing robust communication technology that can respond effectively to natural disaster and intentional attacks.

3. “A Biologically Inspired Adaptive Working Memory System for Efficient Robot Control and Learning” (0325641, D. Mitchell Wilkes, Vanderbilt University). This research seeks to emulate in robots the highly flexible and efficient system for dealing with tasks possessed by humans and primates, involving working (short-term) memory and related executive functions located in the prefrontal cortex of the brain.

4. “Virus-Inspired Declarative Geometric Computation” (0218435, Meera Sitharam, University of Florida). Development of dynamic geometric models of how viruses are assembled out of their constituent proteins will encourage new thinking about how to represent the geometry of assembly in general in ways that will be computationally tractable.

5. “Designer Gene Networks for Biocomputing Applications” (0130331, James Collins, Boston University). “This project involves the use of techniques from nonlinear dynamics and molecular biology to model, design and construct synthetic gene networks for biocomputing applications.” One possible area of application would be redesigning living cells to function as computer components, and interfacing them with conventional electronic computers.

6. “Multiple-Word DNA Computing on Surfaces” (0130108, Lloyd Smith, University of Wisconsin at Madison). This work develops tools for carrying out computations, including a number of logical and arithmetic operations that are important for computer science, by encoding information into the nucleotide sequence of DNA and manipulating it within nanoscale dimensions on surfaces.

7. “Biomolecular Computing by DNA/Enzyme Systems” (0113443, Erik Winfree, California Institute of Technology). This project develops “techniques and instruments for high-precision quantitative analysis of DNA molecular devices,” such as DNA switches, in order “to leverage the advanced control over biochemical systems to begin establishing a broader foundation for reliable molecular computing.”

8. “Self-Assembly of DNA Nano-Scale Structures for Computation” (0086015, John Reif, Duke University). This work explores methods for employing DNA self-assembly to carry out massively parallel computations, to solve difficult problems such as factoring large integers.

### **Computational Neuroscience**

The National Science Foundation does not generally support research intended to improve the diagnosis or treatment of disease, because that is the mission of the National Institutes of Health. However, NSF does support fundamental scientific research in neuroscience, from both biological and cognitive-science perspectives, in addition to a variety of kinds of research that compare the human nervous system with computers in order to advance information technology that will be maximally useful to people.

1. “High-Resolution Cortical Imaging of Brain Electrical Activity” (0218736 and 0411898, Bin He, University of Illinois at Chicago and University of Minnesota at Twin Cities). This work seeks to improve the spatial and temporal resolution of brain activity research by computationally combining data from functional magnetic resonance imaging with data from electroencephalography that measures electrical potentials on the scalp.

2. “Using Humanoids to Understand Humans” (0325383 Christopher Atkeson, Carnegie-Mellon University; 0326095 Stefan Schaal, University of Southern California). This research uses robots, programmed to imitate human behavior, to develop computational theories of human motor control, which potentially could help develop therapies or assistive technologies for people who are in danger of falling.

3. “Personalized Spatial Audio via Scientific Computing and Computer Vision” (0086075, Larry Davis, University of Maryland at College Park). The human ability to determine what direction a sound is coming from and to hear one voice among many sounds is affected by the way sound is scattered by the person’s own body; this research will improve our mathematical understanding of this



phenomenon, and thus make it possible to produce more realistic audio computationally.

4. “Partial Differential Equation Based Nonlinear Algorithms for Processing Multi-Scale Audio Signals” (0219004, Jack Xin, University of Texas at Austin). Research to model the nonlinearities in the pathways by which sound travels through the human ear and is perceived by the brain will contribute to the design of digital hearing aids, audio compression, and research on human sensory abilities.

5. “A Novel Grid Architecture Integrating Real-Time Data and Intervention During Image Guided Therapy” (0427183, Kim Baldrige, University of California at San Diego; 0426558, Simon Warfield, Brigham and Women’s Hospital). Computer technology will be developed to measure and model the deformation of the human brain during neurosurgery or other treatments, thus improving the quality of treatment and providing more information to guide postoperative analysis.

6. “Community Access for the Brain Injury Population” (0313324, Stephen Fickas, University of Oregon). This work seeks fundamental knowledge to design wearable navigation devices so they will really be valuable for people who suffer the effects of traumatic brain injury, by determining their actual needs, developing means to assess their impairments, and developing procedures so that custom-designed devices will serve their users’ needs effectively.

7. “Towards Organic Computing in Computer Vision and Robotics” (0312802, Stefan Schaal, University of Southern California). The portions of the human brain devoted to vision have vastly greater computing power than comparable machine systems, and this theoretical and experimental research seeks “radically new design principles” for robot control and computer vision that would emulate organic computing.

8. “A System for Data Integration and Pattern Discovery in Multimodal, Spatio-Temporal Data: Lesion Analysis and Data Sharing” (0312629, Fillia Makedon, Dartmouth College). This work develops “new mechanisms for data sharing and research collaboration, fast pattern discovery and a testbed for developing standards for sharing sensitive information,” thereby facilitating research and treatment of “Multiple Sclerosis (MS), a brain disease that can lead to loss of motor and memory skills and even death.”

### **Cognitive Technologies**

Until very recently, people have trended not to recognize the extent that many technologies are specifically designed to enhance human cognition, but

now we realize that it is useful to distinguish “cognitive technologies” as a special category of engineering largely based upon cognitive science. Many of these cognitive technologies concern education, and a key cognitive issue is human–technology interaction.

1. “Augmented Cognition: Combining Human and Digital Memory” (0121629, Randy Pausch, Carnegie-Mellon University). This work develops “infocockpits” – information display systems that exploit human cognitive strengths, notably the mental associations between information and the direction and place it was learned – “multiple spatial displays surrounding the user,” and “ambient context displays (both visual and auditory).”

2. “Mapping Meetings: Language Technology to make Sense of Human Interaction” (0121396, Nelson Morgan, International Computer Science Institute). Computerized language technology is used to study the group dynamics of meetings by mapping the changing topics discussed and the social roles and relationships of the people participating; one practical result would be methods for producing automatic summaries of meetings and their decisions.

3. “Managing Human Attention” (0325351, Robert Kraut, Carnegie-Mellon University). Integrating principles from “social psychology, computer science, economics, and interaction design,” this project develops and evaluates “techniques to mediate among the often competing demands of responding to a barrage of communication requests.”

4. “Universal Access for Situationally Induced Impairments: Modeling, Prototyping, and Evaluation” (0121570, Andrew Sears, University of Maryland at Baltimore County). By analogy with computing and communications technologies designed for permanently disabled individuals, this research applies concepts from cognitive science and methods from information technology to the problem of assisting ordinary people under poor lighting conditions, in noisy environments, and when traveling – that is, under conditions “when the physical, cognitive, or perceptual demands placed on the user exceed their abilities.”

5. “Adaptive Spoken Dialog with Human and Computer Partners” (0325188, Susan Brennan, State University of New York at Stony Brook). This research “examines how people adapt to both human and computer conversational partners, through variation in pronunciation (e.g., dialect), rhythm, word choice, sentence structure, and perspective,” with the aim of gaining the knowledge necessary to build computerized spoken dialog systems that serve a variety of needs.

6. “Information Access to Spoken Documents” (0085940, Joseph Picone, Mississippi State University). Research on the problem of using automatic speech recognition to extract information from spoken language will lead “to advances in information extraction from telephone messages, conversations, university lectures, or from any text (such as encyclopedias), and should potentially serve as the basis for a sorely needed sophisticated web browser technology and data mining applications, which in turn would enable people who currently under-utilize computers to become full participants in the information revolution.”

7. “Integration of Stochastic and Dynamical Methods for Speech Technology” (0113508, Michael Johnson, Marquette University). This work integrates “two traditionally distinct research fields, statistical signal processing and chaotic systems,” in order to make possible improved speech classification and recognition by machines.

8. “Digital Imaging Techniques for the Simulation and Enhancement of Low Vision” (0113310, James Ferwerda, Cornell University). This research has two phases: (1) to develop simulation methods to show researchers and technology designers with normal vision what a person with low vision sees, and (2) to create “low vision image enhancement tools that can be used to transform images from digital cameras or graphics applications to create new images that are more comprehensible to people with low vision.”

### **Educational Technologies**

These projects blend cognitive science and information technologies to develop technologies to enhance learning. The usual focus is on school children or college students, but in the future world of Converging Technologies, people of all ages will often need to learn new scientific-technical knowledge quickly, efficiently, and outside the traditional classroom context. Thus, these radical new learning technologies, based on convergence of cognitive and information sciences, will promote convergence of all sciences and technologies.

1. “Putting a Face on Cognitive Tutors: Bringing Active Inquiry into Active Problem Solving” (0205301, Albert Corbett, Carnegie-Mellon University; 0205506, Michelene Chi, University of Pittsburgh). “Cognitive tutors are built around a cognitive model of problem solving knowledge,” and this project will integrate this technology with an interactive questioning environment “to produce an inactive learning environment that rivals the effectiveness of human tutors.”

2. “Tutoring Scientific Explanations via Natural Language Dialogue” (0325054, Kurt VanLehn, University of Pittsburgh). The challenge for this project is to make natural language based computer tutoring systems more effective through “a multidisciplinary effort whose intellectual merit lies in new results in the cognitive psychology of human tutoring.”

3. “Monitoring Emotions while Students Learn with AutoTutor” (0325428, Arthur Graesser, University of Memphis). “This research investigates emotions during the process of learning and reasoning while college students interact with complex learning environments” to study “introductory computer literacy or conceptual physics.”

4. “Creating the Next Generation of Intelligent Animated Conversational Agents” (0086107, Ronald Cole, University of Colorado at Boulder). “The goal of this project is to improve reading achievement of children with reading problems by designing computer-based interactive reading tutors that incorporate new speech and language technologies.”

5. “Integrating Speech and User Modeling in a Reading Tutor that Listens” (0326153, David Mostow, Carnegie Mellon University). Methods from cognitive psychology and several branches of information technology are being combined to develop “a computational student model of children’s oral reading” and to “estimate various component literacy skills at a sufficiently fine grain size to guide the decisions of an intelligent tutor, so as to adapt to students’ individual or collective educational needs.”

6. “iLearn: IT-enabled Intelligent and Ubiquitous Access to Educational Opportunities for Blind Students” (0326544, Sethuraman Panchanathan, Arizona State University). Research in visual and speech processing, information fusion, and “customized delivery of information to blind users adapted to context and task” will help visually impaired students benefit from printed material, online course material, and the wider campus environment.

7. “A Learning Environment for Information Technology Concepts Using Intensive, Unobtrusive Assessment” (0121345, Steven Tanimoto, University of Washington). This work experiments with integrating unobtrusively gathered information about a student’s cognition into learning environments for teaching aspects of information technology.

8. “Tutoring Explanation and Discovery Learning: Achieving Deep Understanding through Tutorial Dialog” (0113864, Vincent Alevan, Carnegie-Mellon University). This project seeks to “yield research advances in computer science, education, and cognitive psychology” by developing new instructional software intended to

teach at the level of explanations and testing “cognitive models of how student understanding emerges from an integration of explicit-verbal and implicit-perceptual learning processes”; for example, when learning geometry.

### **Human–Technology Interaction**

Human–computer interaction is a well-established subfield at the intersection of information technology and cognitive science, and it can readily be expanded to cover all forms of technology with which people interact. Although studies of the impact of new technologies can be valuable, far more worthwhile is integrating usability and implication studies directly into the design process, so that the resultant technology will achieve maximum benefit for human beings.

1. “Cognitive and Social Design of Robotic Assistants” (0121426, Sara Kiesler, Carnegie-Mellon University). “The research will contribute to theory on people’s interactions with robots, facilitate useful and graceful interactions between people and robotic assistants, and advance robotic technology and dialogue on ethical issues surrounding deployment of life-like robots.”

2. “Intelligent Human-Machine Interface and Control for Highly Automated Chemical Screening Processes” (0426852, David Kaber, North Carolina State University). “High-throughput toxicity screening (testing) of dangerous chemical agents for effects on human cells and cell functions is a rapidly developing international, biotechnology industry” using advanced robots that are supervised by humans. This work will develop an adaptive, intelligent interface to reduce worker stress while improving accuracy, “based on cognitive modeling of supervisory controller behaviors during actual chemical screening processes.”

3. “Research on the Perceptual Aspects of Locomotion Interfaces” (0121084, William Thompson, University of Utah; 0121038, John Rieser, Vanderbilt University; 0121044, Herbert Pick, University of Minnesota at Twin Cities; 0120984, Claude Fennema, Mount Holyoke College). A major limitation of virtual reality environments is that they do not allow human users to walk around in large spaces, coupling perception with action. This collaborative research project seeks to overcome this limitation by investigating “how to synergistically combine visual information generated by computer graphics with biomechanical information generated by devices that simulate walking on real surfaces.”

4. “Situationally Appropriate Interaction” (0121560, Scott Hudson, Carnegie-Mellon University). This project develops

“situationally appropriate interfaces that retrieve, generate, and deliver information in a manner that is sensitive to the situation of the user. These interfaces will allow for communication and information systems that maneuver, rather than blunder, through the social world.”

5. “The Vocal Joystick: Voice-based Assistive Technology for Individuals with Motor Impairments” (0326382, Jeffrey Bilmes, University of Washington). This research will develop a high-bandwidth, voice-operated control device that will help people with motor impairments control computers at the same time that it advances “our understanding of human interface technology in general, and speech-based technology in particular.”

6. “Multimodal Human Computer Interaction: Toward a Proactive Computer” (0085980, Thomas Huang, University of Illinois at Urbana-Champaign). In order to make computers more proactive in their support for human activities, this project develops methods for giving the computer more information about the user, including the task the user is engaged in and the emotions of the user.

7. “Rapid Evaluation of User Interfaces in Multitasking Environments” (0426674, Dario Salvucci, Drexel University). Cognitive architectures that simulate the user’s cognition and behavior allow “a designer to rapidly evaluate new interfaces through stages of rapid prototyping, task demonstration, integrated model creation, and computational simulation.”

8. “Coordination of Heterogeneous Teams (Humans, Agents, Robots) for Emergency Response” (0205526, Katia Sycara, Carnegie Mellon University). This is research on the formation and coordination of hybrid teams, consisting of many humans and semiautonomous machines. Although motivated by the need to use robots effectively in emergency situations, this research can be applied as well to scientific exploration of hazardous environments, and more generally to scientific collaboration between humans and machines.

### **Transforming Tools**

In order to unify the sciences and the technologies that are based on them, it is not enough merely to promote interdisciplinary research with multidisciplinary teams. Rather, it is essential to develop transdisciplinary research, development, and communication methodologies. These are the chief enabling tools that will render full convergence possible.

1. “Visualization of Multi-Valued Scientific Data: Applying Ideas from Art and Perceptual Psychology” (0086065, David Laidlaw, Brown University). Inspired by applications in geography, neurobiology, and the human circulatory system, this work draws on knowledge from cognitive science to develop information science tools for visualizing physical phenomena, following such approaches as virtual reality, immersive environments, and formal methods of visual design.

2. “An Infrastructure for Designing and Conducting Remote Laboratories” (0326309, Sven Esche, Stevens Institute of Technology). The goal is to integrate “a variety of resources for remote laboratories so that users can run experiments involving multiple devices in different labs in different locations” and to study related cognitive issues, thereby developing means to encourage collaboration, the combination of experiments with simulations, and education of students who are distant from the laboratories.

3. “Building the Tree of Life – A National Resource for Phyloinformatics and Computational Phylogenetics” (0331654, Bernard Moret, University of New Mexico; 0331648, Francine Berman, University of California at San Diego; 0331453, Tandy Warnow, University of Texas at Austin; 0331494, Satish Rao, University of California at Berkeley; 0331495, David Swofford, Florida State University). This Cyberinfrastructure for Phylogenetic Research (CIPRes) project brings together biologists, computer scientists, and mathematicians from 13 institutions to develop new techniques for estimating the evolutionary relatedness of diverse species from genetic data.

4. “Pattern Recognition for Ecological Science and Environmental Monitoring” (0326052, Thomas Dietterich, Oregon State University). Development of a computer vision system designed to recognize and count insects belonging to different species will provide a new tool for studies of biodiversity, for water quality monitoring, and for basic research in entomology.

5. “Sustainable and Generalizable Technologies to Support Collaboration in Science” (0085951, Gary Olson, University of Michigan at Ann Arbor). This project develops a taxonomy of online research collaboratories and identifies the social and technical factors that favor success across a range of fields, including atmospheric science, behavioral neuroscience, biomedical informatics, computer science, earth science, engineering, genomics, and nanoscience.

6. “Adapting Massively Multi-User Technologies for Collaborative Online Interactive Science Laboratories” (0325211, Gerald Meisner, University of North Carolina at Greensboro). This

project adapts online multiplayer game technology to develop a three-dimensional virtual world “in which students meet and conduct collaborative scientific investigations as they proceed through a series of learning modules” that teach physics.

7. “A Digital Video Collaboratory to Integrate IT Innovations in Video Analysis, Sharing and Collaboration into Scientific Research Communities” (0326497, Roy Pea, Stanford University; 0324883, Brian MacWhinney, Carnegie-Mellon University). The aim of this collaborative project is to create both a toolkit of technologies and an online collaboratory that will help researchers at multiple locations and in multiple disciplines cooperate in analyzing videos relevant to a range of sciences.

8. “Materials Computation Center” (0325939, Duane Johnson, University of Illinois at Urbana-Champaign). This center for computational materials research and education develops “new approaches for understanding complex materials using advanced computational methods” following such approaches as “quantum simulations, complex systems and phase transformations, and computer science and scaleable parallel methods for materials modeling.”



### APPENDIX 3: COMMERCIALIZING AND MANAGING THE CONVERGING NEW TECHNOLOGIES

*Michael Radnor and Jeffrey D. Strauss, Northwestern University*

This is the Executive Summary of the report “Commercializing and Managing the Converging new Technologies” based on an industry, government, and academic workshop, sponsored by the National Science Foundation in 2003 and published by Northwestern University in 2004. Participants in the workshop and follow-on meetings represented the organizations listed below.

<b>1. Industry (includes service and associations)</b>		
Andrew Corporation	Global Futures	Philips
Agere Systems	IBM	Risk Group
Applera	Intel	Rockwell Automation
Atomworks	Kingsbury	Siemens Westinghouse
Caterpillar	Kraft	SMI
Converging Technologies Bar Association	Lockheed Martin	Stillwater
John Deere	Massmep	United Technologies
DuPont	Material Sciences	WESTEC
First Analysis	Motorola	
Foley & Lardner	NACFAM	<b>MATI-Fellows:</b>
Ford	Nanosphere	Baxter
General Monitors	NCMS	Bell Labs
General Motors		General Motors
<b>2. Federal</b>		
NASA	OSTP	U.S. Dept. of Commerce
NSF	Sandia	U.S. Dept. of Education
<b>3. Academic Institutions</b>		
Albuquerque Tech.	Japan Advanced Institute of Technology	Technion
Arizona State Univ.	MIT	University of Virginia
ETH-Zurich	Northern Illinois Tech	Woodrow Wilson Center
Georgia Tech	Northwestern Univ.	Worcester Poly. Institute
Hope College	Ohio State University	

## **Introduction**

With the convergence of Nanotechnology, Biotechnology, Information technology and Cognitive science (NBIC) fields promising to change our competitive, operational, and employment landscape in fundamental ways, we find ourselves on the brink of a new technological and science-driven business revolution.

The already emerging reality of convergence is to be found in genomics, robotics, bio-information and artificial intelligence applications, such as:

- Self-assembled, self-cleaning and self-healing manufactured materials and textiles, and much stronger, lighter and more customizable structural materials,
- Miniature sensors allowing unobtrusive real-time health monitoring and dramatically improved diagnosis; with greatly enhanced real time information to vehicles and drivers on the way,
- New generations of supercomputers and efficient energy generators based on biological processes,
- Greatly enhanced drug delivery from unprecedented control over fundamental structural properties and biocompatibility of materials.

These advances are here already, or in development. And Japan, other Asian nations and Western European countries are investing heavily and moving aggressively to develop and apply NBIC technologies.

Notwithstanding the passage of the 21st Century Nanotechnology Research and Development Act, significant further funding and action by both government and private industry will be critical to maintaining US scientific and industry leadership.

## **Business Implications**

Creating value from commercialization of the converging new technologies will require more than technology development. This summary highlights key points from a September 2003 workshop on this topic that built on the outputs of a 2001 NSF workshop on converging technologies. Part of a multi-stage and iterative process to capture the perspectives of key stakeholders and, particularly the voice of industry, its objective was to identify critical perceived challenges, issues and support requirements related to NBIC commercialization and management and to lay the foundation for a meaningful program of action for industry, academia and government. The explicit intent of the workshop was to raise issues and consider the potential of convergence beyond the scientific and technological focus of other programs.

Following the workshop, a series of largely industry teleconferences and informal discussions significantly expanded participant number and range. Finally, the report was reviewed by the industry community and by selected other management experts to ensure it reflects a true practice consensus view. The workshop and follow-on discussions brought together a deliberately broad mix of practitioners, crossing the traditional thought and experience “silos” dividing “scientists” and business people” and reflecting the recognition that in the emerging new world, separating these communities could only lead to failure born of superficiality. The approximately 90 participants included faculty, representatives of government agencies and national labs, legal and venture capital sector practitioners, and, particularly, business managers, coming from large medium and small organizations.

Industry participants raised the following guiding questions:

- What needs to happen to manufacturing, IP requirements, standards, and other organizational requirements for evolving and converging technologies to be effectively applied?
- What evidence of convergence can already be seen, in which areas, in what form and at what pace?
- What are the emerging drivers and inhibitors?
- What forms of collaboration across disciplines will be required?
- What types and levels of investment will be needed by whom – and when?
- How will corporate research and project portfolios need to be refocused?
- To capitalize on and co-evolve with convergence, how must organizations change their fundamental relationships, structures, models and practices?
- What new skills will be required and how will they be instilled? What foundations and connections will be needed? What are the implications for basic educational preparation?
- What is going on globally? What is the full picture of US comparative position in the evolving world?
- How will markets and “fields” be identified and defined? Knowing what developments corporate engineers and scientists should monitor, and how to evaluate what they see will be a challenge.
- Who will be the players – the winners/losers? Given our science leadership in the key component fields, how can we ensure America also leads in commercialization?

#### Implementation Issues that were raised:

- The challenging transition from legacy systems: We will have to recognize and overcome outdated assumptions, bridge organizational silos and position convergence in the organization.
- Difficulty in assessing, identifying and building appropriate markets for convergence based products and services. Although participants were eager to identify product applications, they recognized the broader challenge of defining high potential product attributes crossing current application fields.
- Poor appreciation of trade-offs, timing issues: Preparation must begin now, despite uncertainty.
- Need for both new generalists and new specialists.
- New manufacturing processes as well as new standards and IP models will be required and legal and regulatory regimes will need to change.
- The changing interaction between science and technology may push business to revisit the role of central labs and require a return to a stronger role for government in supporting research and science policy.

#### “Pressing” needs outlined by workshop participants:

- Enhanced coordination, vision and support, specifically:
  - To galvanize action, the vision must be national in scope.
  - A comprehensive not-for-profit industry-government-university research and support association will be needed.
  - A continually revised and dynamic high level roadmap that can track convergence and applications must be built, complete with:
    - the specification of inhibitors, enablers as well as scenario variations and indicators;
    - related micro roadmaps with interim/transitional milestones.
- Mechanisms to encourage collaboration across business sectors and scientific disciplines, including:
  - “Translators” or “bridges” between groups;
  - Workshops;
  - A widely accessible Website and/or newsletter;
  - Task forces around key topics defined through further discussion.
- A workforce prepared for convergence (e.g., improved training, educational materials and methods) will be a must.
- A refined, interlocked and integrated management planning toolset based on assessment of current and potential models: This toolset should address organizational constraints, enable ongoing monitoring of developments, and support communication and coordination.

It was strongly stated that unless we deal with these needs effectively and NOW, the US will cede to others key ingredients and drivers of next generation innovation-based jobs and global competitiveness; that, dealing with the implied challenges will require informed top level knowledge, high priority attention and significant and sustained investment that grows as the field emerges, from both industry and government; a closer pattern of industry-government-academic collaboration will be needed than has been the norm; and, the workshop and what it has already begun to trigger is a good start, but must be expanded upon and leveraged.

### **What Industry Must Do: The Recommendations**

The workshop consensus was that industry must consider more than the current “low hanging fruit” opportunities. The key question for decision-makers is:

How can we, through high quality intelligence and appropriate preparation, become adaptively enabled to position ourselves and to cope with the risk threats and grasp the opportunities upon which robust growth platforms can be developed – as convergent technologies fields evolve and mature?

Such a question demands action response to a number of key challenges for commercializing converging technologies:

- Begin to adapt and co-evolve our organizations – their cultures, management practices and processes/tools need to be well fitted to the new emerging fields.
- Adjust corporate mindsets to enhance flexibility, challenge assumptions and rapidly and appropriately respond to evolving opportunities, threats and conditions.
- Prepare for and begin to build local and global partnerships and alliances that will be needed in research and education, marketing, supply chains, etc.
- Define and begin to build new and interdisciplinary competencies. As corporate citizens, contribute to the building of such competencies at the K-12 as well as at the workforce and higher education levels.
- Ensure we can, and do, recognize, monitor and evaluate the developments that we should, wherever they may occur and, potentially, in very new ways.

Implementing the needed charter in strongly science, technology and market driven worlds calls for a changed alliance among government, academia and the

private sector. As a key example, all three sectors will need to collaborate in the evolution of new curricula and materials to enable better preparation of students at the undergraduate and graduate levels – and perhaps even earlier, for an effective future workforce.

The opportunities are real but the challenges are substantial. The full impact of convergence may not be felt for some time, but when it does come, it will likely be too large and have too fast and too fundamental an impact to allow laggards to catch up. But, winners may achieve dominance that crosses and alters a wide range of industries and defines new competitive arenas.

### **Workshop Results**

That the relatively quickly arranged and single day workshop produced as much as it did is testimony to the growing academic, government, and particularly, industry interest and concern with convergence. There is, however, a clear need for deeper, more systematic and sustained effort.

#### *An Evolving Tool Set*

A key need expressed by participants was for a toolset to enable assessment, planning and management related to convergence. Tools were presented at the workshop, and additional tools and processes were subsequently suggested which, if integrated effectively have the potential to meet the needs described. Nonetheless the toolset remains incomplete with further development required:

- Domain mapping to make potential market-pull explicit,
- Mind mapping to encourage identification of new options and threats,
- Scenario planning to stretch thinking and challenge the robustness of strategy under varying possible conditions,
- Product/technology roadmapping – a new, developing tool to graphically show how pieces of a complex technological system and business will fit together, interact and evolve as an operation is carried out while considering scientific, technological and operational contexts,
- Metrics to assess convergence and guide/evaluate planning & operations,
- Life Cycle Risk Management models to provide focused, cross-functional support systems that rapidly drive new products to market,
- Knowledge/environment mapping to highlight the interplay of key environmental factors over time.

*An Agenda for Industry-Academic Research and Education*

1. From a new baseline analysis of current and evolving investment patterns and priorities in the US as compared to competing nations, establish our private, academic and government position in the converging new fields.
2. Explore how, where and when convergent technologies applications will become manifest. Research tasks should include:
  - Develop arrays of interacting and intersecting roadmaps,
  - Identify indicators to monitor,
  - Develop new metrics,
  - Identify new development patterns likely to emerge.
3. Investigate what will be the emergent requirements to enable, accelerate and sustain the potential applications:
  - Human resources (competencies, training, recruitment, distribution)
  - Intelligence (gathering, monitoring, interpreting and disseminating)
  - Tools that can deal with the new uncertainties and complexities (decision making and strategy, planning, control, collaboration)
  - New organizational forms (inter-/intra-; networking and alliances)
  - Support systems.
4. Carry out studies of the “new” issues – in the transitional and ultimate states:
  - Competitiveness impacts (new/old industries, domestic & global)
  - Changing worlds – knowledge (academia, others), industry and market structures, etc.; new economies
  - Social (concerns/tensions), political (policies, funding) impacts.
5. New global relations patterns and implications (knowledge flows, cooperation, developed-developing worlds).
6. Fundamental educational issues (structure, process and content; K-12 through higher and technical systems).

**Action Outcomes: What’s Been Achieved So Far**

1. The workshop demonstrated increased industry interest in capitalizing on converging technologies and began to define issues.
2. Case studies and key tools adapted to convergence are emerging.
3. Support and research networks of company managers, academics, and association representatives from over 40 institutions are already evolving.
4. The necessary process of identifying and defining critical practical issues and factors that would act as enablers and progress barriers was started.

### Proposed Next Steps

Because of expected resistance to change and the high level of complexity, uncertainty and context-specific variability, these steps can only be indicative at this time, pending research, further development and industry response.

1. Key steps that will build on progress already made:

- Refine, augment and pursue research topics through industry and academic study teams. Early targets should include identifying and assessing assumptions likely to inhibit cross-sector/cross-disciplinary communication and the development of a new facilitating lexicons and metaphors.
- Refine and adapt tools along with guides to support assessment of current models and the design and use of customized new approaches.
- Adjust corporate mindsets to enhance flexibility, challenge assumptions and rapidly and appropriately respond to evolving opportunities, threats and conditions.
- Refine and expand website; develop other communication and dissemination mechanisms.

2. Organize task forces drawing on the research and support networks and specified areas of interest.

3. Build multi-sector teams to begin high-level convergence roadmapping.

4. Define convergence related core skills and competencies and stimulate these through further development, testing and dissemination of training/teaching materials and models.

5. Design and conduct follow-on workshops.

6. Set up a *Convergence Association* focused on overcoming managerial, organizational and other non-technical barriers to commercializing and managing convergence:

- Actively involve the full stakeholder range.
- Include a wide spectrum of industry sectors, regulators, legal, financial, governmental and academic organizations and other research institutions.

### A Closing Word

The workshop established that convergence of the new NBIC technologies has the potential to dramatically alter how we live and produce value. Issues and obstacles were laid out that must be addressed if this potential is to be translated into practical and commercial outcomes for US industry. The urgent need for action was stressed. Specific needs for new coordination and communication across disciplines, sectors and organizations, related roadmapping and other tools and the critical development of new skills and refinements in training and education were noted. Tools are beginning to evolve and be adapted to address



convergence needs. The speed and extent to which progress has already been made is encouraging. A strong support and research network has been established and continues to grow.

These results and the planned steps, are a small but important beginning for the actions and the roadmap needed to achieve effective commercialization and management for the converging new NBIC technologies. But for a program to succeed, deep and sustained commitment backed by substantial resources coming from industry, academia and government working in a true partnership will be vital.

## INDEX

- Accreditation Board for  
Engineering and Technology  
(ABET), 83
- ACT-IF, 198
- action plans, 24
- activities, 246
- ACT-R, 193, 195
- adaptiveness, 249
- advisor, 209
- affinity, 321
- Affymetrix, 183
- Afghanistan, 113
- Africa, 319
- AgBioWorld Foundation, 303
- Agency for Healthcare Research  
and Quality, 54
- agents, 194, 198, 326, 339
- Agilent, 183
- aging, 41, 120, 156, 175, 268, 304,  
325
- agriculture, 259, 268, 339
- AIDS, 106
- alcohol addiction, 123, 176
- algeny, 290
- algorithms, 148
- Alzheimer's Disease (AD), 154,  
156
- ambivalence, 213
- American Society of Bioethics and  
Humanities, 289
- Amiens Cathedral, 218
- Amish, 271, 300
- AnaLogic Computers, 134
- Analogical and Neural Computing  
Laboratory, 134
- Angola, 113
- ANNE, 209
- antennas, 109, 134, 137
- anthropology, 14
- anthropometry, 217, 222, 223
- anti-abortion movement, 286
- anti-technological ideology, 275
- Apple Computer, 183
- applications, 27, 30, 337, 372
- Applied Digital, 58
- appropriate technologies, 107
- ApproTEC, 107
- architecture, 27, 236
- Arpanet, 77
- artificial intelligence, 4, 5, 199, 203,  
204, 206, 208, 303, 310, 312, 370
- asbestos, 66
- assessment, 374
- associative memories, 146
- atomic bomb, 78
- atomic force microscope (AFM),  
61, 125
- attention, 197, 265
- augmentation, 231, 234
- Australia, 65
- autobiography, 217
- autoimmune diseases, 120
- automation, 231, 233
- autonomy, 166
- avatars, 222, 328
- Bangalore, 183
- Bangladesh, 105, 329
- beauty, 268
- bias, 185, 329
- bibliometrics, 64
- biocompatibility, 121, 127
- biocomplexity, 13
- biocomputing, 347, 358
- bioethicists, 299
- bioethics, 256, 286, 287, 289
- biofeedback, 180, 185, 341
- bioinformatics, 154, 204, 347, 355,  
357
- bio-inspired designs, 125
- biomarkers, 180
- Biomimetic Microelectronic  
Systems (BMES), 182
- biomimetics, 10
- biotech clusters, 182

- birth rates, 112
- book publication, 234
- Boston University, 55
- brain, 5, 134, 142, 165, 176, 186, 204, 302, 343, 344
- brain fingerprinting, 281
- brain imaging, 155, 164, 179
- brain interfaces, 339
- brain scans, 188
- brain, electrical stimulation of, 177, 180
- Brazil, 104
- Buddhism, 205
- business, 227, 236, 244
- business models, 4, 10, 20, 244
- Cambodia, 113
- Canada, 49
- cancer, 123, 124, 128
- capabilities, 243
- capability-rich environment, 243
- capitalism, 162, 298, 313, 314
- carbon nanotubes, 127, 311, 350
- Carnegie Mellon University, 194, 217
- case studies, 64
- caste system, 299
- Cathedral of St. John the Divine, 220
- cell phones, 135, 196, 272
- cellular architecture, 134, 138, 148
- Cellular Neural/nonlinear Network-based (CNN) systems, 134
- Center for Bioethics and Culture (CBC), 295
- Center for Bioethics and Human Dignity (CBHD), 297
- Center for Biological and Environmental Nanotechnology, 55
- Center for Biological Nanotechnology, 127
- Center for Cognitive Liberty and Ethics, 302
- Center for Genetics and Society, 299
- Center for Nano Science and Technology, 133
- Center for Nanotechnology, 55
- certainty, 283
- checks and balances, 261
- chemical toxicity, 120
- chemotherapy, 123, 124
- China, 39, 105, 183
- choice, 166
- Christianity, 205
- Cisco Systems, 183
- citizenship, 320
- class, 323
- climate change, 314, 331
- cloning, 287, 290, 293, 295, 300, 311
- coal, 40
- coevolution, 227, 228, 238, 243, 250
- cognitive, 179
- cognitive architecture, 193
- cognitive modeling, 193, 196
- cognitive neuroscience, 360
- cognitive prostheses, 154
- cognitive science trends, 3, 29, 38, 204
- cognitive technologies, 5, 153, 203, 206, 223, 347, 362
- Cognitive Tutor, 199
- cognitive, definition of, 193
- cognoinformatics, 357
- collaboration, 5, 231, 235, 247, 372
- collaboratory, 5, 235
- collective experience, 218
- Columbia University, 218, 220
- commercialization, 49, 264, 369, 370
- commodification, 290, 296
- communication problem, 268
- communication technologies, 275
- competitive advantage, 181

- competitiveness, 375
- complexity, 10, 193, 229, 244, 343
- computational nanoscience, 347, 348
- computational neuroscience, 347
- computer scientists, 91
- conflict, 2
- Confucianism, 205
- consensus, 260, 339
- consilience, 203
- consumers, 316
- convergence at the nanoscale, 11
- Converging Technologies Bar Association, 18
- Converging Technologies for the European Knowledge Society, 50
- converging technologies, definition of, 9, 48
- converging technologies, future of, 23, 48
- converging technologies, impacts of, 1, 67
- converging technologies, scope of, 26, 37
- coordination tools, 246
- Copenhagen University, 114
- core competencies, 57
- Cornell Nanobiotechnology Cluster, 183
- Cornell University, 54
- Cortex Pharmaceuticals, 156
- cortical cells, 134
- creativity, 338
- creole, 74, 75, 84
- criminals, 188
- Crystal Palace, 218
- Cuba, 113
- cultural conflict, 97, 100
- cultural differentiation, 329
- cultural inertia, 333
- cultural landscape, 309
- culture, 93, 327, 338, 342
- culture, of R&D, 259
- cultures, two, 84, 262, 274
- curriculum, 84, 339
- custom design, 338
- cyberinfrastructure, 89, 91, 95, 99
- cybernation, 223
- cyberscience, 89
- cyborgs, 301, 303, 304, 324
- cystic fibrosis, 124
- Dana Foundation, 186
- Danforth Foundation, 81
- decentralization, 260
- decentralized industry, 311
- Defense Advanced Research Projects Agency (DARPA), 217
- degenerative diseases, 5, 120
- delegation, 231, 235
- dementia, 156
- dendrimers, 61, 127
- dendrites, 140
- Department of Agriculture, 53, 81
- Department of Commerce, 1, 47
- Department of Defense, 10, 107
- Department of Energy, 10, 41
- Department of Health and Human Services, 54, 176
- depression, 176
- designer babies, 294
- developing countries, 5, 103, 115
- development, rate of, 255, 257
- developmental diseases, 5, 120
- diagnostics, 122, 177, 179, 180, 280
- diaries, 84
- digital libraries, 216
- diodes, 135
- direct democracy, 319
- direction of movement, 139
- directional selectivity, 139, 141
- disabilities, 122, 129, 339, 343
- disciplines, new, 240
- Discovery Institute, 296
- disease, 129, 267
- divergence, 11
- division of labor, 77, 96, 227, 250

- Dow Chemical, 58  
 Dow Jones Industrial Average, 56, 58  
 dreams, 164  
 drug delivery, 123, 177, 370  
 drug policy, 157  
 drug resistance, 259  
 drug use, 157  
 DS cells, 139  
 Dupont, 56  
 dynamic associative memories, 146  
 earthquake engineering, 5, 91, 94, 100  
 Eastman Kodak Company, 56  
 ecology, 299  
 economic growth, 186, 267, 315  
 economic opportunities, 33  
 economics, 105, 236, 264, 291, 309, 313  
 economy, segments of the, 248  
 education, 16, 62, 82, 106, 112, 149, 188, 235, 275, 339, 342, 345, 362, 371, 375  
 education, informal, 84  
 educational technologies, 347, 363  
 Egypt, 205  
 electromagnetism, 228  
 electron beam lithography, 135  
 electronic town halls, 317  
 emerging technology, 255  
 emoticeuticals, 179  
 emotion, 160, 164, 179, 184, 209, 210, 213, 223, 341  
 empathy, 164, 184  
 endothelial cells, 75  
 energy, 39  
 England, 104  
 enhancement, 5, 43, 187, 188, 255, 256, 263, 265, 266, 270, 271, 286, 289, 300, 344  
 enlightenment, 206  
 entrepreneurship, 5, 107  
 environmental disorders, 5, 120  
 environmental groups, 267, 300  
 environmental issues, 16  
 Environmental Protection Agency, 10  
 environmental remediation, 256, 268  
 EPIC, 193  
 equitable distribution of benefits, 20  
 error, 197, 282  
 ETC Group, 48, 49, 66, 81, 267, 275, 300  
 ethical issues, 129, 255, 256, 266, 281, 339  
 ethics, 6, 154, 186, 187, 269, 273, 312  
 Ethics and Public Policy Center, 297  
 ethnicity, 332  
 eugenics, 294, 296, 299  
 EuroBarometer, 292  
 Europe, 104, 260, 319  
 European Brain Council, 186  
 European Dana Alliance for the Brain, 186  
 European Federation of Neurological Associations, 186  
 European Union, 48, 50, 65, 173  
 EUTECUS Inc., 134  
 evidentiary reliability, 281  
 exams, 83  
 Experience-on-Demand, 217  
 expertise, 78  
 expertise, multidisciplinary, 15  
 exploitation, 230  
 exploration, 230, 264  
 Extropy Institute, 301  
 Exxon, 58  
 eye, 139  
 factor analysis, 213  
 fashion, 82  
 Federal Reserve, 184, 315  
 financial trading, 183  
 Finland, 104

- Food and Drug Administration, 107, 155, 157  
 foraging, 197  
 forecasting, 173  
 Foresight Institute, 65, 183, 297, 301  
 forgetting, 158  
 Foundation on Economic Trends, 290  
 Franklin D. Roosevelt Presidential Library and Museum, 218  
 freedom, 273, 277, 323  
 freedom of thought, 165  
 Friends of the Earth, 300  
 furniture, 82  
 future, predicting the, 173  
 game theory, 229  
 ganglion cells, 134, 142  
 Gates Foundation, 109, 116  
 gender equality, 106  
 gene therapy, 123, 266, 294, 304  
 gene transfer, 127  
 Genentech, 183  
 genetic engineering, 3, 265, 287, 290, 293, 295, 300, 301, 303, 324  
 genetic revolution, 256  
 genetically modified organisms, 81, 259, 311, 313  
 genomic informatics, 42  
 genomics, 177, 310, 370  
 Georgia Institute of Technology, 55  
 Germany, 186  
 Gestalt psychology, 71  
 Global Alliance of Mental Illness Advocacy Networks, 186  
 Global Brain, 113  
 global economy, 104  
 globalization, 314, 325  
 goals, 73, 195, 230, 264, 269  
 God, 80, 290  
 GOMS, 194, 196  
 Google, 163  
 government spending, 5, 52  
 Grameen Bank, 105  
 Gramercy Park, 219  
 grand challenges, 28  
 Great Britain, 186  
 green fluorescent protein, 143  
 green revolution, 81  
 Greenpeace, 267, 303  
 gross domestic product (GDP), 37, 39, 44  
 gross national product (GNP), 314  
 growth trends, 27  
 H. B. Fuller Company, 56  
 happiness, 159, 185  
 Harvard University, 105, 114, 142  
 health, 119, 160  
 health care system, 41, 42, 130, 162, 280  
 health information infrastructure, 53  
 health insurance, 289  
 health, global, 110  
 heart attacks, 129  
 heart disease, 123  
 helplessness, 210  
 Hewlett Packard, 58, 111  
 Hinduism, 205  
 Hippocratic oath, 161  
 Hitachi, Ltd, 57  
 Hoffman-LaRoche, 159  
 hostility, 73  
 human benefit, 263  
 Human Brain Project, 178  
 human condition, 163  
 human dignity, 285, 295  
 human enhancement, 153  
 human flourishing, 255, 257, 265  
 human identity, 155, 160  
 human nature, 16, 20, 129, 230, 266, 267, 296  
 human performance, 4, 10, 38, 43, 49, 80, 115, 153, 187, 255, 256, 263, 265, 268, 286, 342  
 human potential, 14, 38, 167  
 human progress, 2

- human psychology, 322
- human resources, 375
- human spirit, 264
- human subjects research, 259
- human-computer interaction, 5, 193, 340, 347, 365
- humanities, 255, 273
- Hungarian Academy of Sciences, 134, 149
- hunger, 106
- hydrogen, 40
- hypertext, 163
- IBM, 58, 183, 218, 242, 250
- icons, 193
- identity, 223, 246, 265, 323, 324, 329, 332
- idiographic research, 212, 216
- illusions, 206
- image processing, 134, 146
- immortality, 205
- immunity, 121
- incommensurability, 74
- India, 105, 107, 115
- industrial waste, 82
- inequality, socio-economic, 51
- infection, 120
- inflation, 314
- information exchange, 11
- information navigation, 197
- Information Technology Research (ITR), 13, 347
- informavores, 197, 230
- Informedia, 217
- infrared, 134, 137
- infrastructure, 16, 264
- inhibition, 141, 142
- innovation, 26, 30, 47, 54, 105, 229, 236, 241, 249, 312
- innovation economy, 5, 33, 37, 44
- instability, 15
- Institute for Advanced Technology in the Humanities, 218
- Institute for Global Futures, 158
- Institute for Soldier Nanotechnologies (ISN), 56
- Institute on Biotechnology and a Human Future, 300
- insulin pumps, 122
- Integrative Graduate Education and Research Traineeship (IGERT), 83
- Intel, 104, 183
- intellectual property, 49
- intelligence, 158, 310, 324
- interactional expert, 78
- interdisciplinary collaboration, 71, 83
- interdisciplinary programs, 52
- interface design, 197
- intergroup hostility, 73
- International Consortium for Brain Mapping, 182
- international exchange, 149
- international implications, 65
- International Monetary Fund, 65
- Internet, 30, 34, 36, 84, 103, 107, 108, 110, 115, 163, 317, 328, 340
- invasiveness, 272
- investment, 4, 228, 244, 371
- investment strategy, 24
- investment, return on, 37
- in-vitro fertilization, 287
- Iran, 110
- Iraq, 107
- Islandians, 328
- Israel, 104, 115
- Japan, 65, 174, 183, 300, 370
- Jet Propulsion Laboratory (JPL), 75
- Jhai Foundation, 108, 116
- jobs, 313
- Johns Hopkins University, 294
- Johnson & Johnson, 58
- Journal of Nanoparticle Research, 60
- jurisprudence, 279
- justice, 280

- Kenya, 107
- Kings College, 114
- landmarks, 219
- landmines, 113
- language, 73
- Laos, 108
- Latin America, 113
- law, 6, 279, 342
- law enforcement, 186
- lawyers, 283
- legacy systems, 372
- legal system, 17
- liberty, 188
- life expectancy, 174, 263
- life extension, 43
- life support, 288
- life-lines, 223
- lifetime information preservation, 5, 203, 216, 223
- linguistics, 210
- Long Term Capital Management (LTCM), 184
- Lucent, 58
- LuxResearch, 56, 58
- lymphocytes, 125
- magnetic resonance imaging (MRI), 79
- management practices, 373
- management principles, 338
- managerial firms, 231
- manufacturing economy, 242
- Marist College, 218
- market, 24, 227, 238, 260, 292, 315, 372
- market price, 184
- Mars, 75
- Massachusetts Institute of Technology (MIT), 56, 74, 77, 105
- materials, 341
- matrix organization, 321
- maturity, 274
- medical care, 287
- medical devices, 179
- medical schools, 161
- medicine, 160
- memantine, 156
- memories, painful, 158
- memory, 5, 265, 344
- memory drugs, 153, 156
- memory enhancement, 43
- Memory Pharmaceuticals, 156
- memory-erasure, 159
- mental health, 325
- mental illness, 176
- mental model, 77
- Merz/Forest Labs, 156
- metadata, 219
- metaphors, 75
- microchips, 181
- Millennium Development Goals, 163
- mistrust, 98
- Mobil, 58
- models, 247
- molecular computing, 3, 350
- molecular machines, 344
- molecular motors, 343
- molecules, design of, 11
- money, 316
- monitoring cellular function, 122
- Monsanto, 81
- Monsanto's Law, 311
- mood, 265, 273
- Moore's Law, 244, 310
- moral behavior, 164
- moral imagination, 80
- morals, 66
- mortality, 106
- motion detectors, 134
- Motorola, 58
- movies, 222
- multidisciplinary research, 128, 133, 149
- multidisciplinary specialists, 227
- multimedia technology, 310



- multimodal data, 217
- MyLifeBits, 218
- nanobiochips, 177
- nanobiosystems, 3
- Nanobiotechnology Center, 54
- nanobots, 129
- nanocomputing, 347, 350
- nanocybernetics, 304
- nanoelectromechanical systems (NEMS), 176
- nanoelectronic devices, 134
- nanoelectronics, 3
- nanoethics, 255
- nanoinformatics, 204, 348, 357
- nanomaterials, 123, 127, 128
- nanomedicine, 124, 129
- nanorobots, 344
- nanoscale wires, 59
- nanoscale, defined, 2
- nanoscale, unity of nature at the, 49, 347
- Nanoscience and Technology Studies Program, 55
- Nanosys, 56, 115, 183
- Nanotechnology Research and Development Act, 52
- nanotechnology, societal implications of, 1
- narratives, 274
- nation states, 321
- National Abortion and Reproductive Rights Action League, 300
- National Aeronautics and Space Administration (NASA), 10, 125
- National Cancer Institute, 52
- National Institute on Drug Abuse (NIDA), 157
- National Institutes of Health, 360
- National Nanotechnology Initiative (NNI), 52, 347
- National Science and Technology Council, 52
- National Science Foundation (NSF), 1, 10, 13, 17, 47, 75, 83, 89, 95, 149, 182, 217, 293, 347, 360, 369
- national security, 15, 188, 338, 341, 344
- natural resources, 2
- NBIC, defined, 1, 228
- Nestlé, 58
- Network for Earthquake Engineering Simulation (NEES), 89, 91
- neural circuitry mapping, 143
- neural networks, 207
- neurobiology, 206
- neuroceuticals, 342
- neurocognitive enhancement, 153
- neurodevices, 180
- neuroethics, 153, 154, 188, 256
- neuroimaging, 177
- neuoinformatics, 180
- neuromorphic technology, 10
- neurons, 5, 125, 141
- neuropharmacology, 153
- neuroscience, 4, 153, 187
- neurotechnology, 5, 166, 173, 179
- neurotechnology clusters, 183
- new markets, 38
- nicotine, 157
- Nissei Sangyo Company, Ltd., 57
- nomenclatures, 16, 19
- nonlinear dynamics, 134
- Nonlinear Electronics Research Laboratory, 134, 146
- nonlinear wave mapping, 148
- nonlinear wave metric computation, 148
- non-spatial government (NSG), 318
- normal, definition of, 129
- norms, 255, 258, 269, 273
- Northern Ireland, 319
- Northwestern University, 369
- novelty, 259

- NSFnet, 90
- nuclear technology, 310
- NYNEX, 194
- object detection, 146
- occupation, 323
- Office of Naval Research, 133
- oil, 39, 314
- oncogenes, 124
- organization, societal, 231
- organizational behavior, 236
- organizational forms, 375
- organizational structures, 338
- outer space, 340
- Palestinians, 319
- Palo Alto Research Center (PARC), 58
- paper industry, 232
- paradigms, scientific, 71
- parallel architectures, 146
- partnership, 257
- Patent and Trademark Office (PTO), 60, 61
- patents, 5, 17, 60, 290
- Pazmany University, 134, 149
- peak experience, 78
- personality, 187, 205, 216, 221, 265
- Peru, 107
- Pfizer, 156
- pharmaceutical genomics, 10
- pharmaceuticals, 179, 265
- photolithography, 3, 135
- photovoltaics, 314
- planning, 374
- plate-tectonics, 72
- policy, 4, 9, 18, 47, 228, 240
- politics, 6, 186, 317
- population trends, 39
- populism, 291
- post hoc ethical reflection, 260
- posthumanity, 289, 296
- post-industrial society, 230
- postmodern medicine, 162
- post-traumatic stress disorder (PTSD), 158
- poverty, 106
- power distance, 93, 95
- precautionary principle, 300
- precedence, 280
- predisposition to disease, 123
- President's Commission for the Study of Ethical Problems in Medicine and Biomedical and Behavioral Research, 287
- President's Council on Bioethics, 159, 166, 187, 267, 286, 288
- priorities for R&D, 10
- privacy, 166, 188, 218, 223
- profit, 259
- propranolol, 158
- prosperity, 44, 274
- prosthetic memory, 163
- prosthetics, 180
- proteome analysis, 177
- prototyping, 95
- pseudorabies virus, 143
- pseudoscience, 281
- psychoanalysis, 206, 213
- psychopharmacology, 154, 187
- public concern, 271
- public forums, 66
- public participation, 67
- public reaction, 260
- quality of life, 38, 44
- quantum computers, 310, 352
- quantum control, 11
- quantum dots, 129, 176, 352
- quantum mechanical tunneling, 136
- quantum nanotechnology, 347
- Question Factory, 211
- radar, 77
- radiation exposure, 125
- Radiation Laboratory, 74
- Radio Frequency Identification (RFID), 58
- Raytheon, 56

- recombinant DNA research, 259
- reflection, 255, 263, 273
- regeneration of tissue, 121
- relationship-oriented computing, 233, 246
- relationships, 245
- relativism, 80
- relativity, 309
- religion, 165, 205, 207, 288, 294, 295, 320
- Renaissance, 11
- renewable energy technology, 310, 314
- representative democracy, 319
- reputation systems, 246
- requirements, design, 96
- Research Experiences for Undergraduates (REU), 17, 149
- research, stages of, 259
- resistance to change, 376
- responsibility, 232
- retina, 139, 142
- retinal processing, 134
- reversibility, 272
- Rice University, 54
- risk, 19, 94, 97, 99, 260, 326
- ritalin, 157, 166, 265, 286
- roadmaps, 4, 13, 23, 372, 375
- robots, 208, 339, 370
- Russia, 104
- Rwanda, 107
- Saegis Pharmaceuticals, 156
- safety, 19, 155
- schizophrenia, 176, 179
- school, 111, 338
- Schools Online, 111
- science fiction, 129, 301
- science, unity of, 276, 345
- scientific community, 282
- scientific evidence, 281, 282
- search engines, 163, 208, 211
- secular humanism, 295
- security, 218
- see-through science, 66
- Segway, 103, 113
- self-sufficiency, 309, 312, 328, 332
- semantic differential, 209, 214
- semantics, 238
- semiconductors, 29
- seminars, 83
- sensocuticals, 179
- sensors, 122, 125, 134, 135, 146, 177, 338, 341, 343, 347, 354, 370
- services economy, 242
- services science, 227, 229, 240, 250
- Sierra Club, 300
- Silicon Valley, 108, 183, 302
- simulations, 3, 85, 90, 94, 100, 331, 340, 348
- single electron transistors, 137
- Singularity, 312, 330
- Soar, 193
- social capital, 330
- social change, 6, 309, 342
- social experiments, 331
- social games, 228, 247
- social memes, 333
- social science, 262, 309, 312, 330
- Social Security, 316, 322
- societal acceptance, 16
- societal implications, 1, 10
- societal implications of nanotechnology, 14
- sociobiology, 1
- software development, 95
- solar cells, 40
- Sony, 58
- South Africa, 111
- South Korea, 183
- Soviet Union, 186
- space exploration, 85
- specialization, 11, 207, 227, 250
- spiritual magic, 205
- sports, 157, 266, 273
- standard of living, 41
- Stanford University, 55, 183

- Star Cellular Neural Network (Star CNN), 146
- starburst cells, 139
- startup companies, 128
- statistical quality control, 241
- stem cells, 114, 291, 294, 311
- stereolithography, 233
- steroids, 157
- stimulants, 157, 187, 273
- strategic alliances, 56
- strategic choice, 269
- strategic planning, 15
- suffering, 129, 187
- suicide, 325
- supercomputers, 90, 370
- supply chains, 373
- Supreme Court, 165, 282
- surrogate mothers, 290
- sustainability, 20, 40, 106, 267, 313, 314
- syncrophobia, 326
- system architectures, 12
- system creation, 11
- task analysis, 194
- technocracy, 276
- techno-economic waves, 174
- technological competencies, 57
- technology clusters, 182
- technology evolution, 25
- technology parks, 18
- technology transfer, 49
- technology, definition of, 103
- technopolitics, 285, 286, 289
- telecommuting, 314, 319
- teleoperation, 234
- telephone, 230
- telepresence, 97
- terrorism, 120
- Texas A&M University, 294
- thalidomide, 66
- theologians, 287
- therapeutics, 123
- thermionic emission, 136
- Toshiba, 58
- toxicity, 124, 127
- trading zones, 71, 74, 76, 257, 269, 276
- trading zones, stages in, 77
- transcendence, 264, 277
- transforming tools, 9, 347, 366
- transhumanism, 285, 295, 296
- Tuskegee Institute, 303
- U. S. Navy, 77
- uncertainty, 93, 97, 99, 376
- uncertainty avoidance, 93
- unemployment, 314
- Union Square Theater, 222
- United Nations, 65, 106, 163, 165, 299
- University of California at Berkeley, 134, 139, 146, 149, 183
- University of California at Los Angeles (UCLA), 182
- University of California at San Diego, 55
- University of California at San Francisco, 183
- University of Chittagong, 105
- University of Georgia, 222
- University of Illinois, 91
- University of Michigan, 55, 112
- University of Notre Dame, 133, 149
- University of South Carolina, 54
- University of Southern California, 182
- University of Virginia, 218
- University of Washington, 54
- university programs, 54
- user-centered design, 96
- value-free science, 261
- values, 66, 80, 299
- videoconferences, 98
- Vietnam, 115
- Vietnam War, 108
- viral adoption of technology, 105

- virtual community, 330
- virtual environments, 100, 219, 342
- virtual reality, 64, 197, 222
- Virtual Vaudeville, 222
- Vision Research Laboratory, 133, 139
- visionaries, 106
- visual computers, 133, 149
- Voxiva, 106, 116
- warfare, 186, 340
- water purification, 113
- wealth, 264
- weather, 90
- welfare state, 292
- wireless telephones, 105
- women's rights, 287, 291
- Woodrow Wilson International Center, 64
- work coordination, 232
- work, organization of, 230
- workers, skilled, 16, 63
- workforce, 63, 372
- workshops, 14, 51
- World Bank, 65, 116
- World Health Organization (WHO), 160
- World Transhumanist Association, 302, 303
- World War II, 79
- World Wide Web, 193, 211, 219, 328
- worlds, other, 264
- worldview, 93
- Xerox, 58
- Yale Law School, 106