

T. R. Crompton



Analysis of Seawater

A Guide for the Analytical and
Environmental Chemist

 Springer

Analysis of Seawater
A Guide for the Analytical
and Environmental Chemist

T.R. Crompton

Analysis of Seawater

A Guide for the Analytical
and Environmental Chemist

With 48 Figures and 45 Tables

 Springer

T.R. Crompton

Hill Cottage (Bwthyn Yr Allt)

Anglesey, Gwynedd

United Kingdom

Library of Congress Control Number: 2005929412

ISBN-10 3-540-26762-X Springer Berlin Heidelberg New York

ISBN-13 978-3-540-26762-1 Springer Berlin Heidelberg New York

DOI 10.1007/b95901

This work is subject to copyright. All rights reserved, whether the whole or part of the material is concerned, specifically the rights of translation, reprinting, reuse of illustrations, recitation, broadcasting, reproduction on microfilm or in any other way, and storage in data banks. Duplication of this publication or parts thereof is permitted only under the provisions of the German Copyright Law of September 9, 1965, in its current version, and permission for use must always be obtained from Springer. Violations are liable for prosecution under the German Copyright Law.

Springer is a part of Springer Science+Business Media

springer.com

© Springer-Verlag Berlin Heidelberg 2006

Printed in Germany

The use of general descriptive names, registered names, trademarks, etc. in this publication does not imply, even in the absence of a specific statement, that such names are exempt from the relevant protective laws and regulations and therefore free for general use.

Product liability: The publishers cannot guarantee the accuracy of any information about dosage and application contained in this book. In every individual case the user must check such information by consulting the relevant literature.

Cover design: *design & production* GmbH, Heidelberg

Typesetting and production: LE-TeX Jelonek, Schmidt & Vöckler GbR, Leipzig, Germany

Printed on acid-free paper 2/3141/YL - 5 4 3 2 1 0

Preface

This book covers all aspects of the analysis of seawater using both classical and the most advanced recently introduced physical techniques.

Until fairly recently, the analysis of seawater was limited to a number of major constituents such as chloride and alkalinity.

It was generally agreed that any determinations of trace metals carried out on seawater prior to about 1975 are questionable, principally due to the adverse effects of contamination during sampling, which were then little understood and lead to artificially high results. It is only in the past few years that methods of adequate sensitivity have become available for true ultra-trace metal determinations in water.

Similar comments apply in the case of organics in seawater, because it has now become possible to resolve the complex mixtures of organics in seawater and achieve the required very low detection limits. Only since the advent of sample preconcentration and mass spectrometry coupled with gas chromatography and high-performance liquid chromatography, and possibly derivatisation of the original sample constituents to convert them into a form suitable for chromatography, has this become possible.

Fortunately, our interest in micro-constituents in the seawater both from the environmental and the nutrient balance points of view has coincided with the availability of advanced instrumentation capable of meeting the analytical needs.

Chapter 1 discusses a very important aspect of seawater analysis, namely sampling. If the sample is not taken correctly, the final result is invalidated, no matter how sophisticated the final analytical procedure. Recent important work on sampling is discussed in detail.

Chapters 2 and 3 discuss the determination of anions. Direct application of many of the classical procedures for anions fail for seawater owing to interfering effects of the simple matrix. Suitable modifications are discussed that are amenable to seawater. Dissolved gases in seawater are of interest in certain contexts and their determination is discussed in Chap. 4.

Chapters 5 and 6 discuss the application of new techniques such as atomic absorption spectrometry with and without graphite furnace and Zeeman background correction, inductively coupled plasma mass spectrometry, X-ray fluo-

rescence spectrometry, neutron activation analysis, voltammetric techniques, and others. In the first part of the chapter elements are discussed singly in alphabetical order, then as the groups of elements, because the newer techniques often cover ranges of elements. Finally, there is a section on metal preconcentration techniques. By concentrating all the metals present in a large volume of sample into a few millilitres, dramatic improvements in detection limited can be achieved, and it is this that enables the techniques to be applicable at the low basal concentrations at which many metals exist in seawater. Increasingly, owing to fallout and the introduction of nuclear power stations and processing plants, it is necessary to monitor the levels of radioactive elements in the seawater, and this is discussed in Chap. 7. Chapters 8 and 9 cover the determination of a wide range of organics in seawater, whilst Chap. 10 covers organometallic compounds. An increasingly long list of organometallics can be detected in seawater, many of these being produced by biologically induced metal methylation processes occurring in sediment and fish tissues.

Finally, in Chap. 11, is discussed the present state of knowledge on the determination of various oxygen demand parameters and non-metallic elements in seawater. Amongst others these include total, dissolved, and volatile organic carbon, and total inorganic carbon, as well as recent work on the older oxygen demand parameters such as chemical oxygen demand and biochemical oxygen demand. The confusion that formerly existed regarding these methodologies is now being resolved to the point that meaningful measurements can now be reported. The determination of other non-metallic elements is also discussed in this chapter.

Whilst the book will be of obvious interest to anyone concerned with seawater environmental protection, it is believed that it will also be of interest to other groups of workers, including River Authorities who have to implement legal requirements regarding seawater pollution, oceanographers, fisheries experts and politicians who create and implement environmental policies, and the news media, who are responsible for making the general public aware of environmental matters.

The book will also be of interest to practising analysts and, not least, to the scientists and environmentalists of the future who are currently passing through the university system and on whom, more than even previously, will rest the responsibility of ensuring that our oceans are protected in the future.

Anglesey, UK, 2006

T.R. Crompton

Contents

1	Sampling and Storage	1
1.1	Sampling	1
1.2	Sampling Devices	3
1.2.1	Intercomparison of Seawater Sampling for Trace Metals	7
1.2.2	Intercomparison of Sampling Devices and Analytical Techniques Using Seawater from a CEPEX (Controlled, Ecosystem Pollution Experiment) Enclosure	12
1.3	Sample Preservation and Storage	17
1.3.1	Losses of Silver, Arsenic, Cadmium, Selenium, and Zinc from Seawater by Sorption on Various Container Surfaces [54]	19
1.3.2	Losses of Phthalic Acid Esters and Polychlorinated Biphenyls from Seawater Samples During Storage	26
1.4	Sample Contamination During Analysis	27
	References	34
2	Determination of Anions	39
2.1	Acetate	39
2.1.1	Ion Chromatography	39
2.2	Acrylate	39
2.2.1	Ion Chromatography	39
2.3	Alkalinity	39
2.3.1	Titration Method	39
2.3.2	Spectrophotometric Methods	40
2.4	Arsenate/Arsenite	41
2.4.1	Spectrophotometric Method	41
2.5	Benzoate	41
2.5.1	Ion Chromatography	41
2.6	Butyrate	41
2.6.1	Ion Chromatography	41
2.7	Borate	42
2.7.1	Spectrophotometric Method	42
2.8	Bromate	42
2.8.1	Spectrophotometric Titration and Differential Pulse Polarography	42

2.9	Bromide	45
2.9.1	Titration Method	45
2.9.2	X-ray Emission Spectrometry	45
2.9.3	Segmented Flow Analysis	46
2.9.4	Solid State Membrane Electrodes	46
2.9.5	X-ray Fluorescence Spectroscopy	46
2.9.6	Isotachoelectrophoresis	46
2.10	Chloride	47
2.10.1	Titration Method	47
2.10.2	Ion Selective Electrodes	47
2.10.3	Chronopotentiometry	48
2.10.4	Miscellaneous	48
2.11	Chromate and Dichromate	48
2.11.1	Atomic Absorption Spectrometry	48
2.11.2	Organic Forms of Chromium	49
2.12	Fluoride	53
2.12.1	Spectrophotometric Method	53
2.12.2	Ion Selective Electrodes	53
2.12.3	Photoactivation Analysis	56
2.12.4	Atomic Absorption Spectrometry	56
2.13	Formate	57
2.13.1	High Performance Liquid Chromatography (HPLC)	57
2.14	Hypochlorite	58
2.14.1	Spectrophotometric Method	58
2.15	Iodate	58
2.15.1	Spectrophotometric Method	58
2.16	Iodide	62
2.16.1	Titration Method	62
2.16.2	Spectrophotometric Method	63
2.16.3	Cathodic Stripping Voltammetry	63
2.16.4	Ion Chromatography	64
2.16.5	Miscellaneous	64
2.17	Molybdate	65
2.17.1	Atomic Absorption Spectrometry	65
2.18	Nitrate	65
2.18.1	Spectrophotometric Methods	65
2.18.2	Ultraviolet Spectroscopy	66
2.18.3	Chemiluminescence Method	68
2.18.4	Flow Injection Analysis	68
2.18.5	Continuous Flow Analysis	69
2.18.6	Cathodic Stripping Voltammetry	69
2.18.7	Ion Chromatography	69
2.18.8	Bacteriological Method	69
2.18.9	Miscellaneous	71

2.19	Nitrite	71
2.19.1	Spectrophotometric Methods	71
2.19.2	Flow Injection Analysis	72
2.19.3	Isotope Dilution Gas Chromatography	72
2.19.4	Cathodic Stripping Voltammetry	72
2.20	Nitrate and Nitrite	73
2.20.1	Spectrophotometric Method	73
2.20.2	Flow Injection Analysis	73
2.20.3	Continuous Flow Analysis	75
2.20.4	Reverse Phase Ion Interaction Liquid Chromatography	75
2.20.5	Miscellaneous	75
2.21	Perrhenate	76
2.22	Phosphate	76
2.22.1	Reverse Flow Injection Analysis	76
2.22.2	Spectrophotometric Method	77
2.22.3	Ion Chromatography	82
2.23	Propionate	82
2.23.1	Ion Chromatography	82
2.24	Pyruvate	82
2.24.1	Ion Chromatography	82
2.25	Selenate/Selenite	82
2.25.1	Fluorometric Method	82
2.26	Silicate	83
2.26.1	Spectrophotometric Methods	83
2.26.2	Flow Injection Analysis	84
2.26.3	Ion Exclusion Chromatography	84
2.27	Sulfide	85
2.27.1	Gas Chromatography	85
2.27.2	Capillary Isotachoelectrophoresis	85
2.28	Sulfate	86
2.28.1	Titration Method	86
2.28.2	Inductively Coupled Plasma Atomic Emission Spectrometry	86
2.28.3	Polarography	87
2.28.4	Ion Chromatography	88
2.29	Valerate	88
2.29.1	Ion Chromatography	88
2.30	Multianion Analysis	88
2.30.1	Spectrophotometric Methods, Phosphate, Arsenate, Arsenite, and Sulfide	88
2.30.2	Electrostatic Ion Chromatography, Bromide, Nitrate, and Iodide	89
2.30.3	Miscellaneous	90
2.31	pH	90
2.32	Suspended Solids	91

2.33	Anion Preconcentration	92
	References	92
3	Anions in Estuary and Coastal Waters	99
3.1	Nitrate	99
3.1.1	Ultraviolet Spectroscopy	99
3.2	Nitrate and Nitrite	99
3.2.1	Autoanalyser Method	99
3.3	Phosphate	100
3.3.1	Spectrophotometric Method	100
3.4	Selenate and Selenite	100
3.4.1	Spectrofluorometric Method	100
3.4.2	Atomic Absorption Spectrometry	101
3.5	Sulfate	101
3.5.1	Spectrophotometric Method	101
3.6	Multianion Analysis	102
3.6.1	Spectrophotometric Method, Sulfate, Phosphate, Nitrate, and Sulfide	102
	References	102
4	Dissolved Gases	103
4.1	Free Chlorine	103
4.1.1	Amperometric Titration Procedures	103
4.2	Ozone	108
4.3	Nitric Oxide	108
4.4	Hydrogen Sulfide	108
4.5	Carbon Dioxide	108
	References	109
5	Cations in Seawater	111
5.1	Introduction	111
5.2	Actinium	112
5.3	Aluminium	112
5.3.1	Spectrophotometric Methods	112
5.3.2	Spectrofluorometric Methods	113
5.3.3	Atomic Absorption Spectrometry	114
5.3.4	Anodic Stripping Voltammetry	114
5.3.5	Gas Chromatography	114
5.4	Ammonium	115
5.4.1	Spectrophotometric Methods	115
5.4.2	Flow Injection Analysis	118
5.4.3	Ion-Selective Electrodes	118
5.4.4	High-Performance Liquid Chromatography	118
5.5	Antimony	119

5.5.1	Atomic Absorption Spectrometry	119
5.5.2	Hydride Generation Atomic Absorption Spectrometry	119
5.6	Arsenic	120
5.6.1	Spectrophotometric Methods	120
5.6.2	Atomic Absorption Spectrometry	121
5.6.3	Neutron Activation Analysis	122
5.6.4	Inductively Coupled Plasma Mass Spectrometry	123
5.6.5	Anodic Stripping Voltammetry	123
5.6.6	X-ray Fluorescence Spectroscopy	124
5.7	Barium	124
5.7.1	Atomic Absorption Spectrometry	124
5.8	Beryllium	125
5.8.1	Graphite Furnace Atomic Absorption Spectrometry	125
5.8.2	Miscellaneous	125
5.9	Bismuth	126
5.9.1	Atomic Absorption Spectrometry	126
5.10	Boron	127
5.10.1	Spectrophotometric Methods	127
5.10.2	Atomic Absorption Spectrometry	128
5.10.3	Coulometry	128
5.11	Cadmium	129
5.11.1	Atomic Absorption Spectrometry	129
5.11.2	Anodic Stripping Voltammetry	134
5.12	Caesium	135
5.12.1	Atomic Absorption Spectrometry	135
5.13	Cerium	136
5.14	Calcium	136
5.14.1	Titration Methods	136
5.14.2	Atomic Absorption Spectrometry	138
5.14.3	Flame Photometry	138
5.14.4	Calcium-Selective Electrodes	138
5.14.5	Inductively Coupled Plasma Atomic Emission Spectrometry	139
5.15	Chromium	139
5.15.1	Total Chromium	139
5.15.2	Chromium (III)	142
5.15.3	Chromium (III) and (VI)	143
5.15.4	Chromium (III) and Total Chromium. Gas Chromatography	145
5.15.5	Organic Forms of Chromium	145
5.16	Cobalt	148
5.16.1	Spectrophotometric Methods	148
5.16.2	Atomic Absorption Spectrometry	149
5.16.3	Flow Injection Analysis	150
5.16.4	Atomic Fluorescence Spectrometry	150
5.16.5	Spectrofluorometry	150

5.16.6	Chemical Luminescence Analysis	150
5.16.7	Cathodic Stripping Voltammetry	151
5.16.8	Polarography	151
5.17	Copper	152
5.17.1	Titration Procedures	153
5.17.2	Atomic Absorption Spectrometry	154
5.17.3	Spectrophotometric Method and Spectrofluorometric Method	155
5.17.4	Ion-Selective Electrodes	155
5.17.5	Electroanalytical Methods	155
5.17.6	Isotope Dilution Methods	157
5.17.7	Electron Spin Resonance Spectrometry	157
5.17.8	Miscellaneous Methods	157
5.17.9	Copper Speciation	157
5.18	Dysprosium	163
5.19	Erbium	163
5.20	Europium	163
5.21	Gadolinium	163
5.22	Gallium	163
5.23	Germanium	163
5.23.1	Hydride Generation Furnace Atomic Absorption Spectrometry	163
5.24	Gold	164
5.24.1	Inductively Coupled Plasma Mass Spectrometry	164
5.24.2	Photometry	164
5.25	Holmium	164
5.26	Indium	164
5.26.1	Neutron Activation Analysis	164
5.27	Iridium	165
5.28	Iron	165
5.28.1	Spectrophotometric Methods	165
5.28.2	Atomic Absorption Spectrometry	166
5.28.3	Chemiluminescence	166
5.28.4	Voltammetry	167
5.28.5	Radioisotope Dilution	167
5.29	Lanthanum	167
5.30	Lead	168
5.30.1	Atomic Fluorescence Spectroscopy	168
5.30.2	Flow Injection Analysis	168
5.30.3	Atomic Absorption Spectrometry	168
5.30.4	Anodic Stripping Voltammetry	172
5.30.5	Mass Spectrometry	174
5.30.6	Miscellaneous	174
5.31	Lithium	174
5.31.1	Atomic Absorption Spectrometry	174

5.31.2	Gel Permeation Chromatography	174
5.31.3	Neutron Activation Analysis	174
5.32	Lutetium	175
5.33	Magnesium	175
5.33.1	Gravimetric Method	175
5.33.2	Atomic Absorption Spectrometry	175
5.34	Manganese	175
5.34.1	Spectrophotometric Methods	176
5.34.2	Spectrofluorometric Method	177
5.34.3	Atomic Absorption Spectrometry	177
5.34.4	Polarography	180
5.34.5	Neutron Activation Analysis	180
5.35	Mercury	180
5.35.1	Atomic Absorption Spectrometry	180
5.35.2	Inductively Coupled Plasma Mass Spectrometry	184
5.35.3	Inductively Coupled Plasma Atomic Emission Spectrometry	184
5.35.4	Atomic Emission Spectrometry	184
5.35.5	Colloid Flotation	184
5.35.6	Miscellaneous	186
5.36	Molybdenum	186
5.36.1	Spectrophotometric Methods	186
5.36.2	Atomic Absorption Spectrometry	187
5.36.3	Inductively Coupled Plasma Mass Spectrometry	188
5.36.4	Electrochemical Methods	188
5.36.5	X-ray Fluorescence Spectrometry	189
5.36.6	Miscellaneous	189
5.37	Neodymium	189
5.38	Neptunium	190
5.39	Nickel	190
5.39.1	Spectrophotometric Method	190
5.39.2	Atomic Absorption Spectrometry	190
5.39.3	Cathodic Stripping Voltammetry	191
5.39.4	Liquid Scintillation Counting	192
5.40	Osmium	192
5.40.1	Resonance Ionisation Mass Spectrometry	192
5.41	Palladium	192
5.42	Platinum	192
5.42.1	Cathodic Stripping Voltammetry	192
5.43	Plutonium	192
5.44	Polonium	193
5.45	Potassium	193
5.45.1	Titration	193
5.45.2	Polarography	193
5.45.3	Ion-Selective Electrodes	194

5.46	Praseodymium	194
5.47	Promethium	194
5.48	Radium	194
5.49	Rare Earths	194
5.49.1	Cerium	194
5.49.2	Praseodymium	195
5.49.3	Neodymium	195
5.49.4	Promethium	195
5.49.5	Samarium	195
5.49.6	Europium	196
5.49.7	Gadolinium	196
5.49.8	Terbium	196
5.49.9	Dysprosium	196
5.49.10	Holmium	196
5.49.11	Erbium	196
5.49.12	Thulium	196
5.49.13	Ytterbium	196
5.49.14	Lutetium	196
5.49.15	Analysis of Rare Earth Mixtures	197
5.50	Rhenium	199
5.50.1	Graphite Furnace Atomic Absorption Spectrometry	199
5.50.2	Neutron Activation Analysis	200
5.51	Rubidium	200
5.51.1	Atomic Absorption Spectrometry	200
5.51.2	Spectrometry	201
5.51.3	Mass Spectrometry	201
5.51.4	X-ray Fluorescence Spectroscopy	201
5.52	Ruthenium	201
5.53	Samarium	201
5.54	Scandium	201
5.55	Selenium	201
5.55.1	Spectrophotometry	202
5.55.2	Atomic Absorption Spectrometry	202
5.55.3	Hydride Generation Atomic Absorption Spectrometry	202
5.55.4	Cathodic Stripping Voltammetry	202
5.55.5	Gas Chromatography	203
5.55.6	Neutron Activation Analysis	203
5.56	Silver	203
5.56.1	Atomic Absorption Spectrometry	203
5.56.2	Neutron Activation Analysis	204
5.57	Sodium	204
5.57.1	Amperometry	204
5.57.2	Polarimetry	204
5.58	Strontium	205

5.58.1	Atomic Absorption Spectrometry	205
5.59	Technetium	205
5.60	Tellurium	205
5.60.1	Atomic Absorption Spectrometry	205
5.61	Terbium	206
5.62	Thallium	206
5.63	Thorium	206
5.63.1	Thermal Ion Mass Spectrometry	206
5.63.2	Neutron Activation Analysis	206
5.64	Thulium	207
5.65	Tin	207
5.65.1	Spectrophotometric Method	207
5.65.2	Atomic Absorption Spectrometry	207
5.65.3	Gas Chromatography	207
5.65.4	High-Performance Liquid Chromatography	209
5.65.5	Anodic Stripping Voltammetry	210
5.65.6	Miscellaneous	211
5.66	Titanium	211
5.66.1	Spectrophotometric Method	211
5.67	Tungsten	211
5.68	Uranium	211
5.68.1	Spectrophotometric Method	211
5.68.2	Cathodic Stripping Voltammetry	211
5.68.3	Polarography	212
5.68.4	Miscellaneous	212
5.69	Vanadium	213
5.69.1	Spectrophotometric Method	213
5.69.2	Atomic Absorption Spectrometry	213
5.69.3	Inductively Coupled Plasma Mass Spectrometry	214
5.69.4	Cathodic Stripping Voltammetry	214
5.69.5	Neutron Activation Analysis	214
5.70	Ytterbium	215
5.71	Yttrium	215
5.72	Zinc	215
5.72.1	Spectrofluorometric Method	216
5.72.2	Atomic Absorption Spectrometry	216
5.72.3	Flow Injection Analysis	217
5.72.4	Stripping Voltammetry	217
5.72.5	Miscellaneous	218
5.73	Zirconium	218
5.74	Multication Analysis	218
5.74.1	Titration Procedures	218
5.74.2	Spectrophotometric Procedure	219
5.74.3	Molecular Photoluminescence Spectrometry	219

5.74.4	Flame Atomic Absorption Spectrometry	220
5.74.5	Graphite Furnace Atomic Absorption Spectrometry	223
5.74.6	Zeeman Graphite Furnace Atomic Absorption Spectrometry	231
5.74.7	Hydride Generation Atomic Absorption Spectrometry	233
5.74.8	Inductively Coupled Plasma Atomic Emission Spectrometry	240
5.74.9	Inductively Coupled Plasma Mass Spectrometry	244
5.74.10	Plasma Emission Spectrometry	248
5.74.11	Anodic Stripping Voltammetry	248
5.74.12	Cathodic Stripping Voltammetry	259
5.74.13	Chronopotentiometry	260
5.74.14	X-ray Fluorescence Spectrometry	261
5.74.15	Neutron Activation Analysis	262
5.74.16	Isotope Dilution Mass Spectrometry	268
5.74.17	High-Performance Liquid Chromatography	271
5.74.18	Metal Speciation	271
5.74.19	Metal Preconcentration	285
5.74.20	Miscellaneous	288
	References	288
6	Cations in Estuary, Bay, and Coastal Waters	313
6.1	Ammonium	313
6.2	Arsenic	314
6.2.1	Hydride Generation Atomic Spectrometry	314
6.3	Barium	314
6.3.1	Atomic Absorption Spectrometry	314
6.4	Cadmium	315
6.4.1	Atomic Absorption Spectrometry	315
6.5	Calcium and Magnesium	316
6.6	Copper	316
6.6.1	Titration Procedure	316
6.6.2	Anodic Stripping Voltammetry	316
6.7	Mercury	317
6.7.1	Miscellaneous	317
6.8	Manganese	318
6.8.1	Polarography	318
6.9	Selenium	318
6.9.1	Hydride Generation Graphite Furnace Atomic Absorption Spectrometry	318
6.10	Tin	318
6.10.1	High-Performance Liquid Chromatography	318
6.11	Multication Analysis	319
6.11.1	Heavy Metals, Isotope Dilution, Spark Source Mass Spectrometry, and Inductively Coupled Plasma Atomic Emission Spectrometry	319

6.11.2	Anodic Stripping Voltammetry	322
6.11.3	Cathodic Stripping Voltammetry	322
6.11.4	Emission Spectrometry	323
6.11.5	Hydride Generation Atomic Spectrometry	323
6.11.6	Inductively Coupled Plasma Mass Spectrometry	323
6.11.7	Preconcentration Techniques	324
6.11.8	Speciation	325
	References	325
7	Radioactive Elements	329
7.1	Naturally Occurring Cations	329
7.1.1	Actinium	329
7.1.2	Polonium and Lead	329
7.1.3	Radium	331
7.1.3.1	Radium, Barium, and Radon	331
7.1.3.2	Radium, Thorium, and Lead	332
7.1.4	⁹⁹ Techneium	333
7.1.5	Thorium	333
7.1.6	Bromide	335
7.1.7	Phosphate	335
7.2	Fallout Products and Nuclear Plant Emissions	336
7.2.1	Americium and Plutonium	336
7.2.2	¹³⁷ Caesium	336
7.2.3	⁶⁰ Cobalt	338
7.2.4	⁵⁵ Iron	338
7.2.5	⁵⁴ Manganese	338
7.2.6	²³⁷ Neptunium	339
7.2.7	Plutonium	339
7.2.8	¹⁰⁶ Ruthenium and Osmium	341
7.2.9	⁹⁰ Strontium	341
7.2.10	Uranium	342
7.2.11	Miscellaneous	344
	References	344
8	Sample Preparation Prior to Analysis for Organics	349
8.1	Soluble Components of Seawater	350
8.1.1	Reverse Osmosis	350
8.1.2	Freeze Drying	350
8.1.3	Freezing-Out Methods	351
8.1.4	Froth Flotation	351
8.1.5	Solvent Extraction	351
8.1.6	Coprecipitation Techniques	353
8.1.7	Adsorption Techniques	354
8.2	Volatile Compounds of Seawater	355

8.2.1	Gas Stripping	355
8.2.2	Headspace Analysis	357
8.2.3	Fractionation	358
8.3	Chemical Pretreatment of Organics	361
	References	362
9	Organic Compounds	365
9.1	Aliphatic Hydrocarbons	366
9.1.1	Spectrofluorometry	366
9.1.2	Dynamic Headspace Analysis	366
9.1.3	Raman Spectroscopy	368
9.1.4	Flow Calorimetry	368
9.2	Aromatic Hydrocarbons	368
9.2.1	Spectrofluorometry	368
9.2.2	High-Performance Liquid Chromatography (HPLC)	369
9.3	Polyaromatic Hydrocarbons	369
9.4	Oil Spills	370
9.4.1	Spectrofluorometry	370
9.4.2	Infrared Spectroscopy	371
9.4.3	Gas Chromatography	373
9.4.4	Gas Chromatography–Mass Spectrometry (GC–MS)	375
9.4.5	Miscellaneous	377
9.5	Carboxylic Acids and Hydroxy Acids	377
9.5.1	Spectrophotometric Method	377
9.5.2	Gas Chromatography	377
9.5.3	Liquid Chromatography	378
9.5.4	Atomic Absorption Spectrometry (AAS)	379
9.5.5	Diffusion Method	379
9.6	Ketones and Aldehydes	380
9.6.1	Spectrophotometric Method, Fluorometric and Chemiluminescence Methods	380
9.6.2	Potential Sweep Voltammetry	380
9.6.3	Gas Chromatography	381
9.7	Phenols	381
9.7.1	Spectrophotometric Methods	381
9.7.2	Gas Chromatography–Mass Spectrometry (GC–MS)	382
9.8	Phthalate Esters	382
9.9	Carbohydrates	382
9.9.1	Spectrophotometry	382
9.9.2	Enzymic Methods	384
9.9.3	Liquid Chromatography	384
9.9.4	Gas Chromatography	385
9.9.5	Miscellaneous	385
9.10	Cationic Surfactants	386

9.10.1	Titration Method	386
9.10.2	Atomic Absorption Spectrometry (AAS)	386
9.10.3	Gas Chromatography–Mass Spectrometry (GC–MS)	386
9.11	Anionic Surfactants	386
9.11.1	Titration	386
9.11.2	Spectrophotometry	387
9.11.3	Atomic Absorption Spectrometry (AAS)	387
9.11.4	High-Performance Liquid Chromatography (HPLC)	388
9.12	Non-Ionic Surfactants	388
9.12.1	Spectrophotometry	388
9.12.2	Atomic Absorption Spectrometry (AAS)	389
9.12.3	Liquid Chromatography–Mass Spectrometry (LC–MS)	389
9.13	Aliphatic Chloro Compounds	390
9.13.1	Gas Chromatography	390
9.13.2	Purge and Trap Analysis	390
9.13.3	Head Space Analysis	391
9.13.4	Miscellaneous	392
9.14	Volatile Organic Compounds	392
9.14.1	Head Space Analysis	392
9.14.2	Stripping Methods	393
9.14.3	Mass Spectrometry	393
9.15	Chlorinated Dioxins	393
9.16	Nitrogen Compounds	393
9.16.1	Spectrofluorometry	394
9.16.2	Proteins and Peptides	397
9.16.3	Nucleic Acids	397
9.16.4	Enzyme Activity	398
9.16.5	Aliphatic and Aromatic Amines	398
9.16.6	Nitro-Compounds	399
9.16.7	Azarenes	400
9.16.8	Urea	400
9.16.9	Hydroxylamine	400
9.16.10	Acrylamide	400
9.16.11	Ethylene Diamine Tetracetic Acid and Nitriloacetic Acid	401
9.17	Sulfur Compounds	401
9.17.1	Alkyl Sulfides and Disulfides	401
9.17.2	Thiols	402
9.17.3	Dimethyl Sulfoxide	402
9.17.4	Thiabend Azole	402
9.17.5	Cysteine and Cystine	403
9.17.6	Miscellaneous	403
9.18	Chlorinated Insecticides	403
9.18.1	Gas Chromatography	403
9.18.2	High-Performance Liquid Chromatography	404

9.19	Polychlorobiphenyls	404
9.19.1	Gas Spectrofluorometry	405
9.19.2	Gas Chromatography	405
9.19.3	Column Chromatography	408
9.19.4	Miscellaneous	409
9.20	Organophosphorus Compounds	409
9.20.1	Spectrophotometric Method	409
9.20.2	Gas Chromatography	410
9.20.3	Enzymatic Methods	410
9.20.4	X-ray Fluorescence Spectrometry	411
9.21	Azine Herbicides	411
9.21.1	Gas Chromatography	411
9.21.2	Gas Chromatography–Mass Spectrometry (GC–MS)	411
9.21.3	High-Performance Liquid Chromatography (HPLC)	411
9.22	Diuron, Irgalol, Chlorothalonil	412
9.23	Lipids	412
9.24	Sterols	413
9.25	Chelators	415
9.26	Humic Materials and Plant Pigments	416
9.27	Vitamins	423
9.28	Cobalamin	423
9.29	Pectenotoxins	423
9.30	Flavins	426
9.31	Microcystine	426
9.32	Preconcentration of Organics	426
	References	426
10	Organometallic Compounds	443
10.1	Organoarsenic Compounds	443
10.1.1	Atomic Absorption Spectrometry	444
10.1.2	Spectrophotometric Method	445
10.1.3	Miscellaneous Methods	446
10.2	Organocadmium Compounds	446
10.2.1	Anodic Scanning Voltammetry	446
10.3	Organocopper Compounds	446
10.4	Organolead Compounds	447
10.5	Organomercury Compounds	447
10.5.1	Atomic Absorption Spectrometry	450
10.5.2	Gas Chromatography	452
10.5.3	Miscellaneous	454
10.6	Organothallium Compounds	454
10.7	Organotin Compounds	455
10.7.1	Atomic Absorption Spectrometry	455
10.7.2	Gas Chromatography	456

10.7.3	Hydride Generation Gas Chromatography–Microwave Induced Atomic Emission Spectrometry (HGGC–MIAES)	459
10.7.4	Thermal Desorption–Gas Chromatography–Inductively Coupled Plasma Mass Spectrometry (TDGC–ICPMS)	460
10.7.5	High-Performance Liquid Chromatography	461
10.7.6	Miscellaneous	461
	References	462
11	Elemental Analysis	467
11.1	Boron	467
11.2	Total Iodine	467
11.3	Organic Nitrogen	468
11.4	Organic Phosphorus	470
11.5	Silicon	471
11.6	Total Sulfur	471
11.7	Carbon Functions	472
11.7.1	Dissolved Organic Carbon	472
11.7.2	Dissolved Inorganic Carbon	487
11.7.3	Particulate Organic Carbon	489
11.7.4	Dissolved Organic Carbon	490
11.7.5	Chemical Oxygen Demand	493
11.7.6	Biochemical Demand	496
11.8	Oxygen Isotopic Ratios	498
	References	498
Subject Index		505

1 Sampling and Storage

1.1 Sampling

Common to all analytical methods is the need for correct sampling. It is still the most critical stage with respect of risks to accuracy in aquatic trace metal chemistry, owing to the potential introduction of contamination. Systematic errors introduced here will make the analysis unreliable. Very severe errors were commonly made during sampling by most laboratories until a decade ago, owing to ignorance or at least underestimation of the problems connected with sampling. This is the principal reason why nearly all trace metal data before about 1975 for the sea and many fresh water systems are to be regarded as inaccurate or at least doubtful.

Surface-water samples are usually collected manually in precleaned polyethylene bottles (from a rubber or plastic boat) from the sea, lakes, and rivers. Sample collection is performed in the front of the bow of boats, against the wind. In the sea, or in larger inland lakes, sufficient distance (about 500 m) in an appropriate wind direction has to be kept between the boat and the research vessel to avoid contamination. The collection of surface water samples from the vessel itself is impossible, considering the heavy metal contamination plume surrounding each ship. Surface water samples are usually taken at 0.3–1 m depth, in order to be representative and to avoid interference by the air/water interfacial layer in which organics and consequently bound heavy metals accumulate. Usually, sample volumes between 0.5 and 2 l are collected. Substantially larger volumes could not be handled in a sufficiently contamination-free manner in subsequent sample pretreatment steps.

Reliable deep-water sampling is a special and demanding art. It usually has to be done from the research vessel. Special devices and techniques have been developed to provide reliable samples.

Samples for mercury analysis should preferably be taken in pre-cleaned flasks. If, as required for the other ecotoxic heavy metals, polyethylene flasks are commonly used for sampling, then an aliquot of the collected water sample for the mercury determination has to be transferred as soon as possible into glass bottles, because mercury losses with time are to be expected in polyethylene bottles.

Ashton and Chan [1] have reviewed the techniques for the collection of seawater samples: preservation, storage, and prevention of contamination are all discussed. The most appropriate measurement techniques, preconcentration and extraction, method validation, and analytical control are all covered. The apparent aluminium content of seawater stored in ordinary containers such as glass and polyethylene bottles decreases gradually, e.g., to half in 2.5 h. But if the samples are acidified with 0.5 ml/l concentrated sulfuric acid the aluminium content remains constant for at least one month. Accordingly, samples should be acidified immediately after collection. However, the aluminium could be recovered by acidifying the stored samples and leaving them for at least five hours.

Shipboard analysis for the sampling of trace metals in seawater has been discussed by Schuessler and Kremling [2] and Dunn et al. [3]. Teasdale et al. have reviewed methods for collection of sediment pore-waters using *in situ* dialysis samples [4]. Bufflap and Allen [5] compared centrifugation, squeezing, vacuum filtration, and dialysis methods for sediment pore-water sampling.

Yamamoto et al. [6] studied preservation of arsenic- and antimony-bearing samples of seawater. One-half of the sample (20 l) was acidified to pH 1 with hydrochloric acid immediately after sampling, and the remaining half was kept without acidification. In order to clarify the effect of acidification on storage, measurements were made over a period of a month after sampling. Results are given in Table 1.1. In this study, a standard addition method and calibration curve method were used for comparison and it was proven that the two gave the same results for the analyses of seawater.

Table 1.1. Effects of storage on the concentration of arsenic and antimony in seawater (mg/l) [6]

Day	As (total)	As (III)	Sb (total)	Sb (III)
1	0.75 (0.66)*	0.30 (0.41)	0.21 (0.21)	0 (0)
2	0.63 (0.73)	0.25 (0.65)	0.21 (0.23)	0 (0)
7	0.70 (0.75)	0.35 (0.42)	0.25 (0.23)	0 (0)
14	0.75 (0.60)	0.19 (0.39)	0.22 (0.23)	0 (0)
30	0.73 (0.68)	0.35 (0.41)	0.19 (0.20)	0 (0)
Average	0.72 ± 0.05 (0.70 ± 0.07)	0.27 ± 0.07 (0.41 ± 0.01)	0.22 ± 0.22 (0.22 ± 0.01)	0 (0)

*Values in parentheses were those for the non-acidified sample.

Yamamoto et al. [6] conclude that their method was quite successful for the species-specific determination of arsenic and antimony in seawater. These methods, especially those for the determination of arsenic (III) and antimony (III), are quite satisfactory, as the method is almost free from interference of foreign ions.

The total concentrations of arsenic and antimony may be underestimated, because organic species of these elements may have been overlooked. There remains ambiguity in defining the difference in concentration of arsenic (total) and arsenic (III) to arsenic (V), and that of antimony (total) and antimony (III) to antimony (V).

1.2 Sampling Devices

The job of the analyst begins with the taking of the sample. The choice of sampling gear can often determine the validity of the sample taken; if contamination is introduced in the sampling process itself, no amount of care in the analysis can save the results. Sampling devices and sample handling for hydrocarbon analysis have been exhaustively reviewed by Green [7].

The highest concentrations of naturally occurring dissolved and particulate organic matter in the oceans are normally found in the surface films. When organic pollutants are present, they too, tend to accumulate in this surface film, particularly if they are either non-polar or surface active. Much of the available information on these surface films is reviewed by Wangersky [8,9].

A major problem in the sampling of surface films is the inclusion of water in the film. In the ideal sampler, only the film of organic molecules, perhaps a few molecular layers in thickness, floating on the water surface, would be removed; the analytical results should then be expressed either in terms of volume taken or of surface area sampled.

In practice, all of the samplers in common use at this time collect some portion of the surface layer of water. Each sampler collects a different slice of the surface layer; thus results expressed in weights per unit volume are only compared when the samples were taken with the same sampler. Of the surface film samplers described in the literature, the "slurp" bottle used by Gordon and Keizer [10] takes perhaps the deepest cut, sampling as far as 3 mm into the water. The sampling apparatus consists simply of an evacuated container from which extend floating tubes with holes. The main advantage of the sampler are its simplicity and low cost. Its disadvantages are the thickness of the water layer sampled and the inherent inability to translate the results of the analysis into units of weight per surface area swept.

A thinner and more uniform slice of the surface can be collected with the Harvey [11] rotating drum sampler. This consists of a floating drum which is rotated by an electric motor, the film adhering to the drum being removed by a windshield wiper blade. The thickness of the layer sampled depends

upon the coating on the drum, the speed with which it rotates, and the water temperature. The slice taken will usually run between 60 and 100 μm . This method has the advantage of sampling a known area of ocean surface, and of collecting a large sample very quickly. However, like most of the other surface film samplers, it must be operated from a small boat and can therefore only be used in calm weather.

The collector most commonly used for the surface films is the Garrett screen [12], a monel metal or stainless steel screen which is dipped vertically below the surface and then raised in a horizontal position through the surface film. The material clinging to the screen is then drained into a collection bottle. This sampler collects a slice of surface somewhere between 150 and 450 μm thick. A relatively small sample, about 20 ml, is collected on each dip, so that the collection of a sample of reasonable size is very time-consuming. This method is also limited to calm weather, since the sampling must be conducted from a small boat. While the Garrett screen has been adopted by many investigators because of its simplicity and low cost, as well as its relative freedom from contamination, it is a far from satisfactory solution to the problem of surface-film sampling. The small size of the sample taken greatly restricts the kinds of information which can be extracted from the sample. Also, the uncertainty as to the thickness of the film samples makes comparison between samplers difficult.

Only one actual comparison of these techniques is available in the literature. Dumas et al. [13] compared the Harvey drum sampler to the Garrett screen, and found greater organic enrichment in both dissolved and particulate matter in the drum samples. The size of the difference between the two samplers suggests that the Garrett screen included 2–3 times as much water as did the Harvey drum.

Several samplers have been constructed on the principle of the use of a specially treated surface to collect surface-active materials. Harvey and Burzell [14] used a glass plate, which was inserted and removed vertically with the material adhering to the plate then collected with a wiper. This method of sampling still includes some water; if a surface which preferentially absorbs hydrophobic or surface-active material is used, for example, Teflon, either normal or specially treated, only the organic materials will be removed, and the water will drain away. Such samplers have been described by Garrett and Burger [15], Larsson et al. [16] and Miget et al. [17], amongst others. Anufrieva et al. [18] used polyurethane sheets, rather than Teflon, as the absorbent. While this sort of sampler seems, at least theoretically, to have many advantages, since the surface swept is easily defined and the underlying water is excluded, the sample taken is very small. In addition, it must be removed from the sampler by elution with an organic solvent, so the chances of contamination from the reagents used are sharply increased.

An interesting method which combines sampling and analysis in one step has been described by Baier [19]. A germanium probe is dipped into the water and carefully withdrawn, bringing with it a layer of surface-active material.

This layer is then analysed directly by internal reflectance infra-red spectroscopy. Since there is no handling of the sample, contamination is reduced to a minimum. However, only infra-red spectral analysis is possible with this system; since the material absorbed on the germanium prism is always a mixture of compounds, and since the spectrophotometer used for the production of the spectra is not a high-precision unit, the information coming from this technique is limited. While identification of specific compounds is not usually possible, changes in spectra, which can be related to the time of day, season, or to singular events, can be observed.

Overall there is still no really satisfactory method for sampling the surface film. Of the methods now in use, the method favoured by most workers is favoured for practical reasons and not for any inherent superiority as a collector. Also, as long as we have no simple accurate method for measuring total dissolved organic carbon, it will be difficult to estimate the efficiency of any surface film collectors.

Sampling the subsurface waters, although simpler than sampling the surface film, also presents some not completely obvious problems. For example, the material from which the sampler is constructed must not add any organic matter to the sample. To be completely safe, then the sampler should be constructed either of glass or of metal. All-glass samplers have been used successfully at shallow depths; these samplers are generally not commercially available [20, 21]. To avoid contamination from material in the surface film, these samplers are often designed to be closed while they are lowered through the surface, and then opened at the depth of sampling. The pressure differential limits the depth of sampling to the upper 100 m; below this depth, implosion of the sampler becomes a problem.

Implosion at greater depth can be prevented either by strengthening the container or by supplying pressure compensation. The first solution has been applied in the Blumer sampler [22]. The glass container is actually a liner inside an aluminium pressure housing; the evacuated sampler is lowered to the required depth, where a rupture disc breaks, allowing the sampler to fill. Even with the aluminium pressure casing, however, the sampler cannot be used below a few thousand metres without damage to the glass liner.

Another approach to the construction of glass sampling containers involves equalisation of pressure during the lowering of the sampler. Such a sampler has been described by Bertoni and Melchiorri-Santolini [23]. Gas pressure is supplied by a standard diver's gas cylinder, through an automatic delivery valve of the type used by SCUBA divers. When the sampler is opened to the water, the pressurising gas is allowed to flow out as the water flows in. The sampler in its original form was designed for use in Lago Maggiore, Italy, where the maximum depth is about 200 m, but in principal it can be built to operate at any depth.

Stainless steel samplers have been devised, largely to prevent organic contamination. Some have been produced commercially. The Bodega-Bodman

sampler and the stainless steel Niskin bottle, formerly manufactured by General Oceanics, Inc., are examples. These bottles are both heavy and expensive. The Bodega–Bodman bottle, designed to take very large samples, can only be attached to the bottom of the sampling wire; therefore, the number of samples taken on a single station is limited by the wire time available, and depth profiles require a great deal of station time.

The limitations of glass and stainless steel samplers have led many workers to use the more readily available plastic samplers, sometimes with the full knowledge of the risks and sometimes with the hope that the effects resulting from the choice of sampler will be small compared with the amounts of organic matter present. The effects of the containers can be of three classes:

1. Organic materials may be contributed to the sample, usually from the plasticisers used in the manufacture of the samplers.
2. Organic materials, particularly hydrophobic compounds, may be absorbed from solution on the walls of the sampler.
3. Organic materials may be absorbed from the surface film or surface waters, then desorbed into the water samples at depth, thereby smearing the real vertical distributions.

The first case is the most likely to be a problem with new plastic samplers. Although there is little in the literature to substantiate the belief, folklore has it that aging most plastic samplers in seawater markedly reduces the subsequent leaching of plasticisers. The second case is known to be a problem; in fact, the effect is used in the various Teflon surface film samplers already mentioned. This problem alone would seem to militate against the use of Teflon for any sampling of organic materials, unless a solvent wash of the sampler is included routinely. With such a solvent wash, we introduce all of the problems of impurities in the reagents.

The third, and largely unexpected, case appeared as a problem in the analysis of petroleum hydrocarbons in seawater [24]. In this case, petroleum hydrocarbons, picked up presumably in the surface layers or surface film, were carried down by the sampling bottles and were measured as part of the pollutant load of the deeper waters. While the possibility of absorption and subsequent release is obviously most acute with hydrophobic compounds and plastic samplers, it does raise a question as to whether any form of sampler which is open on its passage through the water column can be used for the collection of surface-active materials. The effects of such transfer of material may be unimportant in the analysis of total organic carbon, but could be a major factor in the analysis of single compounds or classes of compounds.

Again, as in the case of the surface film samplers, information on the comparative merits of the various water samplers is largely anecdotal. Although such studies are not inspiring and require an inordinate amount of time, both on the hydrographical wire and in the laboratory, they are as necessary for a proper interpretation of data as are intercalibration studies of the analytical

methods. The lack of comparison studies of the various samplers increases the probability of polemics in the literature.

Smith [25] has described a device for sampling immediately above the sediment water interface of the ocean. The device consists of a nozzle supported by a benthic sled, a hose, and a centrifugal deck pump, and is operated from a floating platform. Water immediately above the sediment surface is drawn through the nozzle and pumped through the hose to the floating platform, where samples are taken. The benthic sled is manipulated by means of a hand winch and a hydrowire.

1.2.1

Intercomparison of Seawater Sampling for Trace Metals

Several round-robin intercalibrations for trace metals in seawater [26–30] have demonstrated a marked improvement in both analytical precision and numerical agreement of results among different laboratories. However, it has often been claimed that spurious results for the determination of metals in seawater can arise unless certain sampling devices and practical methods of sampler deployment are applied to the collection of seawater samples. It is therefore desirable that the biases arising through the use of different, commonly used sampling techniques be assessed to decide upon the most appropriate technique(s) for both oceanic baseline and nearshore pollution studies.

Two international organisations, the International Council for the Exploration of the Sea (ICES) and the Intergovernmental Oceanographic Commission (IOC), have sponsored activities aimed at improving the determination of trace constituents in seawater through intercalibrations. Since 1975, ICES has conducted a series of trace metal intercalibrations to assess the comparability of data from a number of laboratories. These exercises have included the analysis of both standard solutions and real seawater samples [26–31]. The considerable improvement in the precision and relevant agreement between laboratories has been reflected in the results of these intercalibrations. By 1979 it had been concluded that sufficient laboratories were capable of conducting high-precision analyses of seawater for several metals to allow an examination to be made of the difference between commonly used sampling techniques for seawater sample collection.

In early 1980, the IOC, with the support of the World Meteorological Organisation (WMO) and the United Nations Environment Program (UNEP), organised a workshop on the intercalibration of sampling procedures at the Bermuda Biological Station, during which the most commonly used sampling bottles and hydrowires were to be inter-compared. This exercise forms part of the IOC/WMO/UNEP Pilot Project on monitoring background levels of selected pollutants in open-ocean waters. Windom [32] had already conducted a survey of the seawater sampling and analytical techniques used by marine laboratories, and the conclusions of the survey were largely used for the selection

of sampling devices to be intercompared. The bottles selected for comparison in Bermuda were modified and unmodified GO-FLO® samplers, modified Niskin® bottles, and unmodified Hydro-Bios® bottles. GO-FLO samplers are the most widely used sampling device for trace metals in seawater. The other two devices continue to be used by several marine laboratories. Windom's [32] 1979 survey established that the most common method of sampler deployment was on hydrowires, as opposed to the use of rosette systems. The hydrowires selected for intercomparison were Kevlar®, stainless steel, and plastic-coated steel. Kevlar and plastic-coated steel were selected because they are widely used in continental shelf and nearshore environments, and are believed to be relevantly "clean".

The method of intercomparison of the various devices was to deploy pairs of sampler types on different hydrowires to collect water samples from a homogeneous body of deep water at Ocean Station S (Panulirus Station) near Bermuda (Fig. 1.1). The water at this depth has characteristics of $3.97 \pm 0.05 \text{ }^\circ\text{C}$

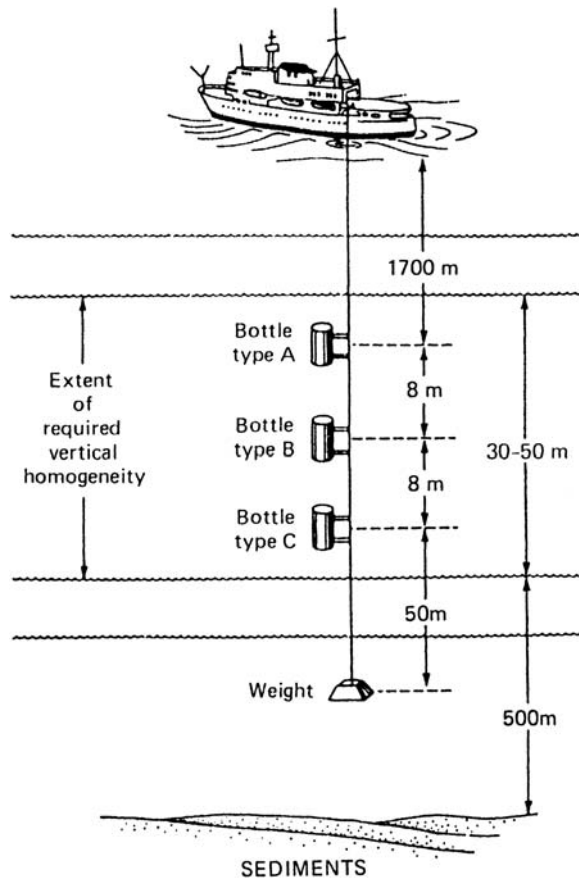

Figure 1.1. Sampling strategy. From [29]

temperature and $35.01 \pm 0.02\%$ salinity for the month of January [33]. The restricted length of Kevlar hydrowire available necessitated the collection of samples in the lower thermocline at depths between 1150 and 1250 m.

Data analysis was reduced to a separate one-way analysis of variance on the data from individual laboratories in order to examine the difference between types of sampling bottle on a single (common) hydrowire, and to determine the influences of the three types of hydrowire using a single type of sampling bottle (modified GO-FLO). Samples were replicated so that there were, in all cases, two or more replicates to determine the lowest level and analytical error.

Replicate unfiltered water samples were collected for each participant for the comparison of pairs of sampling bottles on different hydrowires [29]. Modified GO-FLO bottles were employed on each of the three hydrowires,

Table 1.2. Numerical comparisons for nickel ($\mu\text{g/l}$)* [29]

Wire Bottle	PCS HB	PCS MGF	SS Mod GF	SS Exw GF	KEV NIS	KEV MGF	PCS MGF	SS MGF	KEV MGF
Laboratory									
1 m sd	0.224	0.205	0.209	0.243	0.233	0.207	0.201	0.226	0.207
	0.015	0.020	0.023	0.013	0.023	0.025	0.029	0.025	0.025
2 m sd	0.298	0.278	0.235	0.235	0.218	0.150	0.223	0.235	0.231
	0.031	0.123	0.077	0.048	0.019	0.018	0.128	0.059	0.119
4 m sd	0.18	0.47	0.47	0.35			0.47	0.41	0.23
	0.07	–	–	0.17			–	0.12	–
5 m sd	0.478	0.221	0.240	0.235	0.273	0.237	0.193	0.238	0.237
	0.066	0.026	0.014	0.012	0.021	0.016	0.048	0.012	0.016
6 m sd	0.340	0.159	0.220	0.238	0.237	0.232	0.159	0.230	0.230
	0.052	0.035	0.030	0.021	0.023	0.026	0.035	0.027	0.024
7 m sd	1.93	163	1.60	1.75			1.63	1.68	1.72
	0.24	0.10	0.37	0.13			0.10	0.27	0.25
8A m sd	0.185	0.100	0.123	0.113	0.160	0.105	0.100	0.119	0.123
	0.041	–	0.005	0.012	0.54	0.010	–	0.009	0.041
10 m sd	0.737	0.357	0.3634	0.353	0.385	0.461	0.413	0.493	0.462
	0.078	0.77	0309	0.131	0.064	0.162	0.159	0.262	0.162
11 m sd	0.511	0.367	0.349	0.365	0.421	0.393	0.367	0.357	0.404
	0.034	0.008	0.034	0.009	0.009	0.027	0.008	0.025	0.037
12 m sd	0.230	0.165							
	0.024	0.036							
13 m sd	0.230	0.200	0.238	0.265	0.204	0.236	0.200	0.250	0.236
	0.036	0.020	0.045	0.007	0.056	0.007	0.020	0.035	0.007

*Numbers result from common computer analyses and not all such figures will be necessarily significant; PCS = Plastic-coated steel hydrowire; SS = Stainless steel (type 302 unlubricated) hydrowire; KEV = Kevlar® hydrowire; HB = Hydro-bios sampler; MGF = Modified GO-FLO sampler; Mod GF = Unmodified GO-FLO sampler; Exw GF = Unmodified GO-FLO sampler; NIS = Modified Niskin sampler; m = mean; sd = standard deviation

and this permitted a comparison of the three types of hydrowire. Only in the cases of iron and manganese were there indications of inhomogeneity at levels that might invalidate the intercomparison. This is assumed to be due to inhomogeneity in the distribution of suspended particulate material, which will influence metals that have major fractions in the particulate phase.

The results obtained by various calibrations in the determination of nickel and copper are shown in Tables 1.2 and 1.3. Table 1.4 gives the differences between sampling devices for copper, as determined by each participant, when these are significant at the 95% and 90% levels of confidence. Only the results of participants that had acceptable analytical performance, as measured by precision and agreement with contemporary consensus values for deep North Atlantic waters (Table 1.5), were used for drawing conclusions.

The experiment reveals that the differences between results obtained through the use of various combinations of hydrowires and samplers are not large, and in no case can they account for the recent decline in the ocean

Table 1.3. Statistical comparisons for nickel [29]

Base comparison	PCS MGF/MGF	PCS HB/MGF	SS MGF/MG	KEV MGF/MGF	KEV NIS/MGF	MGF WIRES
Laboratory						
1	NS	Sig HB>MGF	Sig GF>MGF	NS	Sig NIS>MGF	Sig SS>KEV>PCS
2	NS	NS	NS	Sig	Sig NIS>MGF	NS
4		Sig	NS			NS
5		Sig HB>MGF	NS		90 NIS>MGF	Sig SS>KEV>PCS
6		Sig HB>MGF	Sig GF>MGF	NS	NS	Sig SS>KEV>PCS
8A		Sig HB>MGF				
10	NS	Sig HB>MGF	NS	Sig	NS	NS
11		Sig HB>MGF	NS	NS	NS	Sig SS>KEV>PCS
12	90	Sig HB>MGF				
13		NS	NS	NS	NS	90 SS>KEV>PCS

PCS = Plastic-coated steel hydrowire; SS = Stainless steel (type 302 unlubricated) hydrowire; KEV = Kevlar® hydrowire; HB = Hydro-bios sampler; MGF = Modified GO-FLO sampler; GF = Unmodified GO-FLO sampler; NIS = Modified Niskin sampler; Sig = Difference is significant ($P < 0.05$); 90 = Difference is significant ($P < 0.01$); NS = Not significant ($P < 0.01$)

Table 1.4. Numerical comparisons for copper ($\mu\text{g/l}$) [29]

Wire:	PCS	PCS	SS	SS	KEV	KEV	PCS	SS	KEV	
Bottle:	HB	MGF	Mod GF	Exw GF	NIS	MGF	MGF	MGF	MGF	
1	m	0.094	0.092	0.095	0.103	0.111	0.131	0.093	0.099	0.120
	sd	0.007	0.009	0.012	0.012	0.011	0.012	0.011	0.012	0.021
2	m	1.000	0.765	0.553	0.620	0.455	0.272	0.650	0.586	0.403
	sd	0.857	0.289	0.261	0.100	0.487	0.185	0.291	0.186	0.298
3	m	0.437	0.180	0.11	0.205	0.447	0.550	0.233	0.208	0.455
	sd	0.347	0.084	0.067	0.034	0.540	0.317	0.081	0.051	0.314
4	m	0.533	0.435	1.25	1.065			0.435	1.158	1.065
	sd	0.163	0.177	0.35	0.177			0.177	0.252	0.177
5	m	0.188	0.063	0.064	0.142	0.101	0.072	0.101	0.103	0.072
	sd	0.108	0.003	0.004	0.010	0.049	0.012	0.059	0.043	0.012
6	m	0.615 [†]	0.070	0.074	0.083	0.121	0.120	0.070	0.079	0.120
	sd	0.560	0.005	0.003	0.004	0.039	0.022	0.005	0.006	0.026
7	m	0.35	0.27	0.71	0.28			0.27	0.50	0.32
	sd	0.29	0.12	0.59	0.23			0.12	0.47	0.37
8B	m	0.155	0.045	0.163	0.278	0.133	0.160	0.045	0.220	0.140
	sd	0.076	0.006	0.044	0.059	0.030	0.037	0.006	0.078	0.038
9	m	0.84	0.32			0.35	0.55	0.32		0.44
	sd	0.79	0.03			0.02	0.21	0.03		0.17
10	m	0.123	0.135	0.158	0.119	0.096	0.100	0.130	0.138	0.101
	sd	0.015	0.003	0.033	0.032	0.015	0.019	0.024	0.037	0.019
11	m	0.195	0.137	0.102	0.106	0.109	0.132	0.137	0.104	0.149
	sd	0.089	0.027	0.005	0.001	0.013	0.019	0.027	0.004	0.073
12	m	0.059 [†]	0.172							
	sd	0.325	0.040							
13	m	0.168	0.101	0.105	0.292	0.133	0.121	0.101	0.186	0.121
	sd	0.063	0.028	0.013	0.006	0.009	0.020	0.028	0.100	0.200

Numbers result from common computer analyses and not all such figures will be necessarily significant. [†] Suspected contamination. All other symbols are the same as those used in Table 1.2.

concentrations of trace metals reported in the literature. Nevertheless, for several metals, most notably copper, nickel, and zinc, significant differences are evident between both bottles and hydrowires. For deep ocean studies the best combination of those tested is undoubtedly modified GO-FLO samplers and plastic-coated steel hydrowire. Except in the cases of mercury and manganese, Hydro-Bios samplers appear to yield higher values than modified GO-FLO samplers. In contrast, Niskin bottles, modified by the replacement of the internal spring by silicone tubing, are capable of collecting samples of comparable quality to those collected by modified GO-FLO samplers for all metals except zinc. Modification to factory-supplied Teflon GO-FLO bottles, (i.e., replacement of O-rings with silicone equivalents and the substitution of all Teflon drain cocks for those originally supplied), do appear to result in a significant

Table 1.5. Results of sampling bottle and hydrowire intercomparison [29]

Metal	Concentration	No of Laboratories	Best combined sampling/ analytical precisions ($\mu\text{g/l}$)	Comparisons Hydrowires Samplers
Cd	0.035 ± 0.016	12	0.001	PCS<(KEV \approx SS) (MGF \approx NIS)<HB<GF
Cu	0.13 ± 0.04	6	0.010	PCS<(KEV \approx SS) (MGF \approx NIS)<HB<GF
	0.51 ± 0.28	6		
Ni	0.21 ± 0.05	7	0.02	PCS<(KEV \approx SS) (MGF \approx NIS \approx GF)<HB
	0.42 ± 0.11	3		
Zn	0.35 ± 0.18	5	0.05	PCS<(KEV \approx SS) MGF<(NIS \approx HB< \approx GF)
Fe	0.41 ± 0.29	3	0.05	PCS<(KEV<SS) (MGF \approx NIS)<GF<HB
Mn	0.064 ± 0.038	2	0.010	(PCS \approx KEV \approx SS) (MGF \approx NIS \approx GF \approx HB)
	0.012 ± 0.006	1	0.003	
Hg	0.007 ± 0.002	2	0.002	Insufficient comparisons
	0.001	1		

*Mean (\pm SD, $\mu\text{g/l}$); Other symbols the same as used in Table 1.4.

reduction in the levels of most metals in seawater samples collected with them. Kevlar and stainless steel hydrowires generally yield measurably greater concentrations of those metals than does plastic-coated steel. These differences, however, are small enough to suggest that these hydrowires are still suitable for trace metal studies of all but the most metal-depleted waters if proper precautions are taken [34–37].

A major conclusion of the Bermuda experiment is that the use of differing sampling devices and hydrowires only accounts for a small portion of the differences between trace metal results from different laboratories. It appears that the major contributions to such differences are analytical artefacts. It is stressed that although the sampling tools available to the marine geochemist appear adequate for the measurement of metal distribution in the ocean, the execution of cooperative monitoring programs for metals should be preceded by mandatory intercomparison of sample storage and analytical procedures.

1.2.2

Intercomparison of Sampling Devices and Analytical Techniques Using Seawater from a CEPEX (Controlled, Ecosystem Pollution Experiment) Enclosure

Wong et al. [38] conducted an intercomparison of sampling devices using seawater at 9 m in a plastic enclosure of 65 m in Saanich Inlet, BC, Canada. The sampling methods were:

1. Peristaltic pumping with Teflon tubing
2. Niskin polyvinyl chloride (PVC) sampler
3. Go-Flo sampler
4. close-open-close sampler
5. Teflon-piston sampler

Sampling was conducted for four days:

1. Day 1 (August 1978) for mercury.
2. Day 2 for lead, cadmium, copper, cobalt, and nickel by Chelex extraction and differential pulse polarography, as well as manganese by Chelex and flameless atomic absorptiometry.
3. Day 3 for lead by isotope dilution.
4. Day 4 for cadmium, copper, iron, lead, and zinc by Freon extraction and flameless atomic absorptiometry.

Samples were processed in clean rooms in the shore laboratory within 30 min of sampling. Results indicated (i) the feasibility of inter-calibrating using the enclosure approach; (ii) the availability of chemical techniques of sufficient precision in the case of copper, nickel, lead, and cobalt for sampler inter-comparison and storage tests; and (iii) a problem in sub-sampling from the captured seawater in a sampler, and the difficulty of commonly used samplers to sample seawater in an uncontaminated way at the desired depth.

The Teflon tubing used in the pumping system, the Niskin sampler and the Go-Flo sampler were cleaned by immersion in 0.05% nitric acid for the tubing and by soaking the inside of the samplers in 0.05% nitric acid overnight, rinsing with distilled water and repeating the dilute acid/distilled water cycle. The close-open-close sampler was cleaned by 0.1 N nitric acid overnight, then rinsed with distilled water until the blank was acceptable. The Teflon-piston sampler was cleaned by sucking in 0.05% nitric acid and standing overnight (in the case of the polythene bag liner used in the Teflon-piston sampler, hydrochloric acid was used instead of nitric acid).

The storage bottles were cleaned as follows. The Pyrex bottles (2 litres) were used for mercury samples only. They were cleaned by filling with a solution of 0.1% KMnO_4 , 0.1% $\text{K}_2\text{S}_2\text{O}_8$, and 2% nitric acid, heated to 80 °C for 2 h, and after cooling and rinsing, stored filled with 2% nitric acid containing 0.01% $\text{K}_2\text{C}_2\text{O}_7$ until ready for use. Conventional 1- or 2 l polyethylene bottles were used for the other metal samples. They were cleaned by Patterson's method [39]. All bottles were stored inside two or three plastic bags to prevent contamination.

For the pumping system, seawater was pumped up from 9 m and collected in the appropriate bottles on the raft and returned to the shore clean laboratory for preservation and/or analysis. For the other four sampling devices, the sampler was lowered to 9 m, allowed to equilibrate for 10 min, closed by triggering mechanism activated by the Teflon messenger, raised to the surface, transferred into the container, transported back by boat and trucked back

to the shore clean laboratory, where samples were drawn. The time between messenger activation and subsampling was about 30 min. For handling of the samples, messengers, Teflon tubing, vinyl-coated hydrowires, and sampling devices, all personnel wore polyethylene gloves to avoid contamination.

The clean laboratory for trace metals was divided into three areas: entrance laboratory (with clothes changing annex), instrument laboratory, and ultra-clean sample preparation laboratory, all under positive pressure with active charcoal filtered air. Personnel using the clean rooms were required to wear hair caps, polyethylene gloves, laboratory coats, and designated shoes. These items are worn only in the clean rooms.

Mercury was determined after suitable digestion by the cold vapour atomic absorption method [40]. Lead was determined after digestion by a stable isotope dilution technique [41–43]. Copper, lead, cadmium, nickel, and cobalt were determined by differential pulse polarography following concentration by Chelex 100 ion-exchange resin [44, 45], and also by the Freon TF extraction technique [46]. Manganese was determined by flameless atomic absorption spectrometry (FAA).

The precision of the procedures under clean room conditions is shown in Table 1.6.

The results in Fig. 1.2 show values between 0.06 and 0.12 nmol/kg. The average mercury contents obtained by pumping, Niskin sampler, Go-Flo sampler, and the close–open–close device are 0.09 ± 0.01 , 0.08 ± 0.03 , and 0.10 ± 0.02 nmol/kg, respectively.

The mercury values obtained by the Teflon-piston sampler were high at 0.21 ± 0.2 nmol/kg due to malfunction with incomplete filling and previous contamination, as indicated by the very low salinity in this set. The values inside the bag were higher than those outside, measured about one month after intercomparison to be 0.02, 0.03, and 0.04 nmol/kg. There was a subsampling problem. The first and second draw of the sampling bottle usually showed a very wide spread of values, as much as 0.07 nmol/kg, e.g., between 0.05 and

Table 1.6. Precision of the procedure for Cu, Ni, Cd, Zn, Fe and Pb as applied in ocean chemistry clean room [38]

Metal	Seawater concentration (nmol/kg)	Blank (nmol)	Relative standard deviation at test level (average of 10 analyses; %)	Recovery (%)
Cd	1.16	0.009	6	83–98
Cu	13.0	0.08	2	95
Ni	14.8	0.12	2	95
Zn	32.3	0.69	2	95
Fe	7.8	0.54	3	90
Pb	0.10	0.02	30	85–100

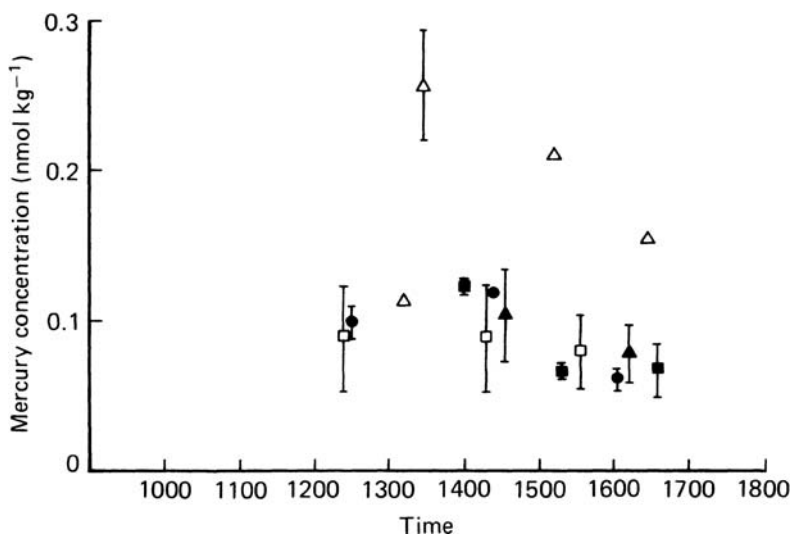

Figure 1.2. Comparison of mercury concentrations found in a CEPEX enclosure using five different sampling methods. ● = Pump; ▲ = Hydrobios; ■ = Go-Flow; □ = Niskin; △ = Seakern. From [38]

0.12 nmol/kg. This difference was real since the technique of cold vapour atomic absorption should be capable of detecting differences in subsamples from the same digested sample in a Pyrex bottle. The peristaltic pumping method appears to yield the best agreement between subsamples, with a difference of 0.02, 0.00, and 0.01 nmol/kg between subsamples from the three casts. The average mercury values for each sampler appeared to converge towards lower values on repeated casts within the same day. Further work is required to clarify contamination in the mercury sampling.

Isotope dilution and mass spectrometry showed the lead values to be 0.73 ± 0.02 , 0.72 ± 0.03 , 0.75 ± 0.02 , 0.78 ± 0.05 , and 0.81 ± 0.03 nmol/kg for sampling by peristaltic pump, Niskin sampler, Go-Flo sampler, close-open-close sampler, and Teflon-piston sampler, respectively (Fig. 1.3). For the other two techniques, the Teflon-piston sampler results showed considerable variability and statistically much higher values. The results were not used in the comparison. The Freon extraction and cold vapour atomic absorption approach showed the same range of values as the isotope dilution approach, i.e., 0.071 ± 0.36 , 0.76 ± 0.13 , 0.73 ± 0.13 nmol/kg for the pumping, Niskin sampler and close-open-close sampler, respectively, with the exception of the Go-Flo sampler with low value of 0.58 ± 0.15 nmol/kg. However, the range of values was wide, e.g., for the peristaltic pumping, 1.12 nmol/kg for the first cast, dropping to 0.46 nmol/kg for the third cast. Chelex extraction and differential pulse polarography showed an even larger spread from 1.09 ± 0.26 nmol/kg for the close-open-close sampler.

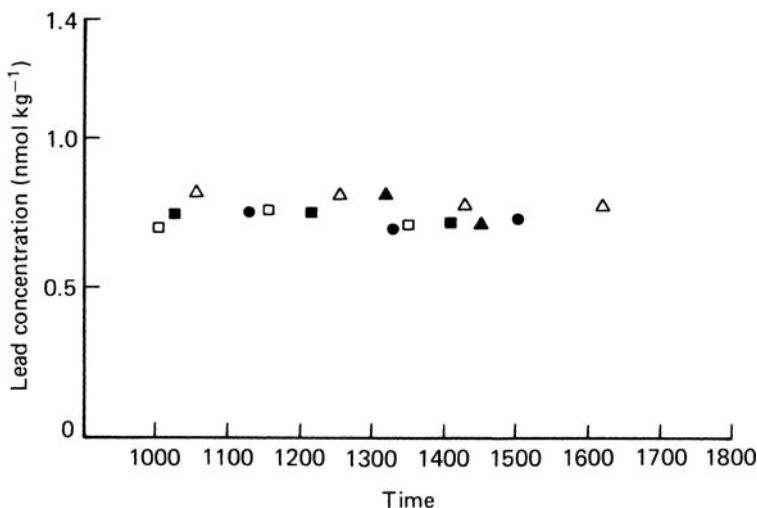

Figure 1.3. Comparison of lead concentrations found in a CEPEX enclosure using five different sampling methods and IDMS analysis. ● = Pump; ▲ = Hydrobios; ■ = Go-Flow; □ = Niskin; △ = Seakern. From [38]

Wong et al. [38] concluded that:

1. It is feasible to capture a large volume of seawater in the range of 65 000 l by the CEPEX approach for the purpose of sampler intercomparison. It is possible by artificial stimulation of a plankton bloom and detritus removal to produce a reasonably homogeneous body of seawater for the study. Proximity of the in situ enclosure for the experiment and the on-shore, clean laboratory facilities eliminate errors introduced by shipboard contamination under less than ideal conditions on cruises.
2. The following analytical techniques seem to be adequate for the concentrations under consideration: copper and nickel by Freon extraction and FAA cold vapour atomic absorption spectrometry, cobalt by Chelex extraction and differential pulse polarography, mercury by cold vapour atomic absorption spectrometry, lead by isotope dilution plus clean room manipulation and mass spectrometry. These techniques may be used to detect changes in the above elements for storage tests: Cu at 8 nmol/kg, Ni at 5 nmol/kg, Co at 0.5 nmol/kg, Hg at 0.1 nmol/kg, and Pb at 0.7 nmol/kg.
3. Salinity of seawater captured by various sampling devices in the CEPEX enclosure indicates problems not revealed in the usual oceanographic sampling situation. Relative to peristaltic pumping, all samples exhibited some salinity anomalies. Inadequate flushing to rinse the sampler of any concentrated brine or entrapped seawater is thought to be a problem.
4. Logistics and cleaning procedures are important factors in successful sampler intercomparison. It is not desirable or possible to endorse or to condemn

the performance of a certain type of sampler or analytical technique based on results of one set of tests, especially if procedures are changed.

5. The problems of subsampling from the same seawater sample has to be studied in greater detail.
6. A long-term but substained effort on sampler intercomparison would be advantageous in identifying problems.

1.3

Sample Preservation and Storage

If we were to choose the ideal method for the analysis of any component of seawater, it would naturally be an in situ method. Where such a method is possible, the problems of sampling and sample handling are eliminated and in many cases we can obtain continuous profiles rather than limited number of discrete samples. In the absence of an in situ method, the next most acceptable alternative is analysis on board ship. A “real-time” analysis not only permits us to choose our next sampling station on the basis of the results of the last station, it also avoids the problem of the storage of samples until the return to a shore laboratory.

While there are a few methods of this type for major constituents, and the advent of the automatic analyser has made possible the adaptation of some micro-methods to shipboard analysis, the majority of chemical analyses, particularly those using the newer, more sophisticated instruments, must still be run on shore. For such samples, the problems of storage and sample preservation becomes all-important, since the quantity we wish to measure is the in situ value and not the amount remaining after some period of biological and chemical activity. Complete oxidation of the organic material to inorganic constituents takes longer than a year [47], however, decomposition great enough to free most inorganic micronutrients takes place within the first two weeks. Important changes in micronutrient levels resulting from bacterial utilisation of organic compounds can be seen after one day. Therefore, some method of preservation of the organic compounds must be sought if the samples are to be taken back to a shore laboratory.

Changes in the distribution of organic compounds in a seawater sample can be due to physical, chemical, or biological factors. As a physical factor, we might consider the absorption of surface-active materials on the walls of the sample container. While this effect cannot be eliminated it can be minimised by the use of the largest convenient sample bottle, and the avoidance of plastic (especially Teflon) containers. Another possible method of eliminating this source of error would be to draw the sample directly into the container in which the analytical reaction is to be run.

If volatile organic materials are present in the sample, plastic sample containers cannot be used. Many small organic molecules are able to diffuse through plastics. If the sample container is not tightly sealed, the volatiles may

escape into the environment. The loss will be greater if the sample is allowed to warm to room temperature. To avoid such losses, sample bottles must be made of glass, with gas-tight seals. They should be filled to the top and stored at low temperature, but above freezing.

The most probable purely chemical reaction to be expected would be photolysis. This possibility can be prevented by storing the sample in the dark. Since most of these organic materials have been present together in seawater for some considerable time, any other reactions are unlikely to occur without an increase in temperature or the inadvertent addition of some catalyst. However, if biologically mediated reactions were to result in the formation of highly reactive species, such as enzymes, further chemical reactions might then occur. Changes in pH, brought about either by biological activity or by the addition of mineral acids as preservatives, might also promote reactions.

Most of the changes taking place in stored seawater are due to biological, and principally bacterial, reactions. In one sense, it might seem strange that removing a sample of water from the ocean complete with its normal bacterial complement should result in any increase in bacterial activity. However, the factor controlling bacterial activity seems to be the available surface area, since free flowing bacteria are not usually growing actively [48, 49]. Thus, enclosing a sample of seawater in a bottle serves to furnish the free-floating bacteria with a large surface to which they can cling and upon which they can multiply. This "bottle effect" is well known, and must be prevented if the results of analysis are to have any meaning.

The two most popular methods of sample preservation are quick-freezing and the addition of inorganic poisons. Samples that are frozen without the addition of preservatives are less likely to pick up contamination from the sample handling. If the sample bottles are to be frozen quickly enough to prevent bacterial growth, the sample bottles must be immersed in a freezing bath, to facilitate heat exchange. Such freezing baths are usually organic; the sealing and handling of sample bottles must be carried out with extreme care, in order to prevent contamination.

While it is normally considered that both biological and chemical reactions will be essentially halted by freezing, this is not necessarily true. It has been shown that some reactions of considerable biochemical importance are in fact enhanced in the frozen state [50–52]. In any given case it cannot simply be taken for granted that freezing will be sufficient preservative; the efficiency of the methods must be tested for the compounds in question. The method is also limited to those analyses that can be performed on a small sample, perhaps 100–200 ml. Larger volumes of seawater take too long to freeze. If the next step in the sample preparation is to be freeze-drying, a considerable saving in time, as well as a decrease in possible contamination, can result from freezing the sample in the container to be used in the freeze-drying.

One is almost forced into hoping that freezing will prove satisfactory as a method of sample preservation, since none of the usual inorganic poisons

works in every case. While mercuric chloride has been found to be effective with those marine organisms responsible for N_2O production [53], it has been found that added radioactive glycine, in the presence of mercuric chloride in seawater, was decomposed slowly in the dark in the apparent absence of bacteria, the radioactive label appearing in the vapour phase. Of the other two most favoured poisons, sodium azide proved to be ineffective in stopping bacterial activity at concentrations as high as 10 mg/l; and cyanide, although effective at levels between 1 and 10 mg/l, interfered with many of the chemical reactions.

Acidification with mineral acids is also often used as a method for preservation of organics. It would be expected that the distribution of organic compounds would be changed by such treatment, even if the total amount of dissolved organic carbon were not appreciably altered. Certainly the volatility of some of the organic molecules of low molecular weight is pH dependent; certain compounds normally retained at the slightly alkaline pH of seawater will be lost during freeze-drying or degassing of acidified samples.

Preservation of organic samples is thus still a major problem; there is no general, foolproof method applicable to all samples and all methods of analysis. The most generally accepted method of sample preservation is storage under refrigeration in the dark, with a preservative. This is another area that still needs extensive investigation.

Tables 1.7 and 1.8 show a selection of reagents used for preserving or fixing various determinands. These reagents are placed in the sample bottle before it is filled with sample; consequently the sample is "protected" from the moment it is taken.

The important influence that sample container materials can have on seawater sample composition is illustrated next by two examples: one concerning the storage of metal solutions in glass and plastic bottles, the other concerning the storage of solutions of phthalic acid esters and polychlorinated biphenyls in glass and plastic.

1.3.1

Losses of Silver, Arsenic, Cadmium, Selenium, and Zinc from Seawater by Sorption on Various Container Surfaces [54]

The following container materials were studied: polyethylene, polytetrafluoroethylene and borosilicate glass. The effect of varying the specific surface R (cm^{-1}) was studied (ratio of inner container surface in contact with solution to volume of the solution) on adsorption of metals on the container surface. New bottles were used exclusively. The differences in R values were achieved by adding pieces of the material being considered. To avoid the possibility of highly active sites for sorption arising from fresh fractures, the edges of the added pieces of borosilicate glass were sealed in a flame. Prior to use of all materials the surfaces were cleaned by shaking with 8 M nitric acid for at least three days and by washing five times with distilled water.

Table 1.7. Details of bottles and fixing reagents (from author's own files)

Analysis	Bottle material	Bottle size	Reagents in bottle	Shelf life	Notes
Dissolved oxygen	Glass	125 ml	None, fixing kit supplied	Unlimited	
Toxic metals	Polyethylene	250 ml 1 ml	10 ml 25% Analar or Aristar HNO ₃	1 Month	If soluble metals to be determined, filter sample before acid addition.
Phenol	Glass	500 ml	40 ml 2% HNO ₃ 1 ml H ₃ PO ₄ and 1 g CuSO ₄ ·5H ₂ O	Made up as needed	Clean plastic Cassella by soaking in acid.
Silica	Polyethylene		None	Made up as needed	
Mercury	Glass	125 ml	7.5 ml 5% K ₂ Cr ₂ O ₇ plus 4 ml conc. H ₂ SO ₄		Bottles filled with 2 N HNO ₃ when not in use; rinsed out before adding reagents.
Chlorophyll	Brown glass	1100 g	None	Unlimited	To be kept out of direct sunlight after filling with sample.
Sulphide	Glass	(A) 110 g ctg (B) Reagent bottle ctg	5 ml 132 g l ⁻¹ Zn acetate and 1 ml acetic acid. 96 g l ⁻¹ sodium carbonate		To bottle already containing 5 ml of solution (A) add sample as quickly as possible, avoiding entrainment of air bubbles. 5 ml of solution (B) is then added to fill the bottle, which should be stoppered and thoroughly mixed.
Pesticides	Glass	1100 g	None	Unlimited	Bottle chromic acid cleaned, ground-glass stoppered and wrapped in polyethylene bag.
Oils	Glass	1100 g	None	Unlimited	Chromic acid cleaned. Separate bottle from main sample, bottle 2/3 filled with sample.
Cyanide	Glass dissolved oxygen bottles		2 NaOH pellets	Made up as needed	

Table 1.8. Sample preservation (from author's own files)

Parameter	Suggested methods	Remarks
Acidity/ Alkalinity	Refrigeration	Gains or losses of CO ₂ affect the result. Microbial action can affect this, should be one of the first analyses of the sample.
BOD	Refrigeration	Refrigeration is only partially effective. Analysis is best done immediately. Large changes can occur over a few hours. Glass bottles preferred
COD	1 Refrigeration 2 acidification with sulfuric acid to pH 2	Changes can occur quite rapidly with some samples. Glass bottles preferred. DoE recommendation. Hydrolysis can occur over longer periods.
Chlorine (residual)	Immediate analysis	No storage possible.
Cyanide	Addition of ascorbic acid, then render alkaline to pH 11–12 with sodium hydroxide	This determinand must be preserved immediately. Need for separate container. Any residual chlorine must be removed with ascorbic acid.
Dissolved oxygen	Winkler reagents	Addition of reagent immediately after sampling. Fixed sample should be kept in the dark and analysed as soon as possible. Where measurements are needed on liquids containing high levels of easily oxidisable organic matter, a portable meter should be used, otherwise the copper sulfate/sulfamic acid mix should be used. DoE recommendation.
Metals (excepting mercury)	<i>Dissolved</i> Filter on site into acid to pH 1–2 <i>Suspended</i> Filter on site <i>Total</i> Acidify to pH 1–2 with hydrochloric or nitric acid	This procedure should be used wherever possible at sewage works when compositing effluents. DoE recommendations vary between 2 and 20 ml, depending on the element. Polythene bottle required. For potable water, acidification must be carried out on receipt in the laboratory; acidified bottles should not be left with sample takers.
Mercury	Nitric acid (5 ml) + 5% potassium dichromate (5 ml) per litre	This treatment must be rendered immediately on sampling otherwise a large proportion can be lost within minutes. Glass bottle must be used (DoE recommendation).
Nitrogen (ammonia, nitrate, organic)	1 Sulfuric acid 2 Chloroform 3 Refrigeration	Chloroform as used effectively. Sulfuric acid is effective and is frequently recommended. Acidification may be recommended by DoE.
Nitrite	Chloroform	Best analysed as soon as possible.
pH	Refrigeration	Immediate analysis advisable, changes can occur quite rapidly, particularly if the container is opened. Well-buffered samples are less susceptible to changes.

Table 1.8. (continued)

Parameter	Suggested methods	Remarks
Phenolics	Copper sulfate 1 g/l + phosphoric acid to reduce pH to less than 4, refrigerated	
Phosphate	1 Sulfuric acid conditioning 2 Use of prepared bottle/refrigeration	Intensive investigation has been carried out on this subject. The concentration of the determinant may affect the method. The DoE recommendation will be for low levels, i.e., less than 25 µg/l, iodised plastic bottles for high levels, acid conditioned glass bottle.
Sulfide	Zinc acetate/sodium carbonate, i.e., 5 ml zinc acetate (110 g zinc acetate + 1 ml acetic acid per litre) + 5 ml sodium carbonate (80 g/l) to 100 ml sample	Must be preserved immediately. Care needed for samples containing much suspended matter; may be DoE recommendation.
Surfactants, anionic	Refrigeration and either 1 Mercuric chloride 1% (2 ml/l) 2 Chloroform (2 ml/l)	These materials can be quite unstable over periods longer than a few hours.
Surfactants, non-ionic	Formaldehyde (5 ml/l)	

Working solutions (1 litre) which were 10^{-7} mol/l in one of the elements to be studied were prepared by appropriate addition of the radioactive stock solutions to pH-adjusted artificial seawater. After the pH had been checked, 100 ml portions were transferred to the bottles to be tested. The filled bottles were shaken continuously and gently in an upright position, at room temperature and in the dark. At certain time intervals, ranging from 1 min to 28 d, 0.1 ml aliquots were taken. These aliquots were counted in a 3×3 in NaI (TI) well-type scintillation detector, coupled to a single-channel analyser with a window setting corresponding to the rays to be measured.

The counting times were chosen in such a way that at least 15 000 pulses were counted. The sorption losses were calculated from the activities of the aliquots and the activity of the aliquot taken at time zero. Taking into account the various sources of errors, mainly counting statistics, the maximum imprecision is about 3%. Therefore, calculated sorption losses of 3% and lower are omitted from the listings as being not significant.

Table 1.9 shows the percentage loss as a function of time for silver, cadmium, and zinc from artificial seawater stored in polyethylene, borosilicate glass, PTFE at various pH and *R* values.

Table 1.9. Sorption behaviour as percentage of silver, cadmium and zinc in artificial seawater [54]

Material	Polyethylene		Silver Borosilicate glass		PTFE		Cadmium Borosilicate glass		Zinc Borosilicate glass		
	8.5	3.4	1.0	4.2	1.0	4.2	1.0	4.2	1.0	4.2	
pH	8.5	3.4	1.0	4.2	1.0	4.2	8.5	4	4	8.5	4
R (cm ⁻¹):	1.4	3.4	1.0	4.2	1.0	4.2	1.0	4.2	1.0	4.2	1.0
contact time											
1 min	-	7	-	-	-	-	-	-	-	-	-
30 min	7	8	-	-	-	-	3	-	-	-	-
1 h	6	5	-	-	3	3	4	-	-	2	31
2 h	10	9	-	-	3	5	6	-	-	910	1
4 h	14	13	-	-	3	4	7	-	-	9	29
8 h	16	18	3	4	5	10	8	-	-	9	30
24 h	24	28	4	4	6	9	12	-	-	5	28
2 d	35	36	6	7	10	31	17	-	-	4	26
3 d	44	45	6	11	31	80	23	-	-	4	21
7 d	64	64	74	60	27	73	14	29	14	4	18
14 d	66	72	81	76	39	84	20	30	10	3	5
21 d	58	77	80	73	39	64	26	37	27	19	9
28 d	46	78	82	71	40	67	27	37	25	17	10
									20	19	9

Cadmium in polyethylene and in PTFE, and zinc in polyethylene, R cm⁻¹ = specific surface area.

For arsenic (added as sodium arsenate) and selenium (added as sodium selenite), losses were insignificant in all the container materials considered, irrespective of matrix composition.

The sorption behaviour of trace elements depends on a variety of factors which, taken together, make sorption losses rather difficult to predict. However, the data from the study and from the literature indicate for which elements sorption losses may be expected as a function of a number of factors, such as trace element concentration, container material, pH, and salinity.

As was shown previously, reduction of contact time and specific surface may be helpful in lowering sorption losses, and acidification with strong acid will generally prevent the problems of losses by sorption. However, it must be emphasised that the use of acids may drastically change the initial composition of aqueous samples, making unambiguous interpretation of the analytical results cumbersome or even impossible [55].

For cases of sample storage where losses cannot be excluded a priori, some sort of check is required. This should be done under conditions representative of the actual sampling, sample storage, and sample analysis. As this study indicates, the use of radiotracers is helpful in making such checks.

The various factors in sorption losses may be classified into four categories. The first category is concerned with the analyte itself, especially its chemical form and concentration. The second category includes the characteristics of the solution, such as the presence of acids (pH), dissolved material, (e.g., salinity, hardness), complexing agents, dissolved gases (especially oxygen, which may influence the oxidation state), suspended matter (competitor in the sorption process), and micro-organisms, (e.g., trace element take-up by algae). The third category comprises the properties of the container, such as its chemical composition, surface roughness, surface cleanliness, and as this study demonstrates, the specific surface. Cleaning by prolonged soaking in 8 M nitric acid [56] is to be recommended. The history of the containers (e.g., age, method of cleaning, previous samples, exposure to heat) is important because it can directly influence the type and number of active sites for sorption. Finally, the fourth category consists of external factors, such as temperature, contact time, access of light, and the occurrence of agitation. All of these factors must be considered in assessing the likelihood of sorption losses during a complete analysis.

Robertson [57] has measured the adsorption of zinc, caesium, strontium, antimony, indium, iron, silver, copper, cobalt, rubidium, scandium, and uranium onto glass and polyethylene containers. Radioactive forms of these elements were added to samples of seawater, the samples were adjusted to the original pH of 8.0, and aliquots were poured into polyethylene bottles, Pyrex-glass bottles and polyethylene bottles contained 1 ml concentrated hydrochloric acid to bring the pH to about 1.5. Adsorption on the containers was observed for storage periods of up to 75 d with the use of a NaI(Tl) well crystal. Negligible adsorption on all containers was registered for zinc, caesium, strontium, and

antimony. Losses of indium, iron, silver, copper, rubidium, scandium, and uranium occurred from water at pH 8.0 in polyethylene (excepting rubidium) or Pyrex glass (excepting silver). With indium, iron, silver and cobalt, acidification to pH 1.5 eliminated adsorption on polyethylene but this was only partly effective with scandium and uranium.

Pellenberg and Church [58] have discussed the storage and processing of estuarine water samples for analysis by atomic absorption spectrometry.

Flegal and Stokes [59] have described a sample processing technique necessary for avoiding lead contamination of seawater samples prior to lead stable isotope measurements by thermal ionisation mass spectrometry. Levels down to 0.02 ng/kg were determined.

To preserve mercury-containing samples [60,61] Coyne and Collins [61] recommended preacidification of the sample bottle with concentrated nitric acid to yield a final pH of 1 in the sample solution. However, when this procedure was used for storage of seawater, fresh water, and distilled deionised water in low density polyethylene storage containers, abnormally high absorption was observed. This absorption at the mercury wavelength (253.7 nm) is due to the presence of volatile organic plasticiser material and any polyethylene residue leached by the concentrated acidified nitric acid and by the acid solution at pH 1. These procedures employ sample storage in polyethylene bottles, and gas phase mercury detection may be subject to artificial mercury absorption due to the presence of organic material.

Reported mercury values in the oceans determined since 1971 span three orders of magnitude, due at least in part to errors induced by incorrect sampling [62–64]. Olafsson [65] has attempted to establish reliable data on mercury concentrations obtained in cruises in North Atlantic water.

The sampling, storage and analytical methods used by Olafsson [65] in this study have been evaluated. The Hydro-Bios water bottles used were modified by replacing internal rubber rings with silicone rubber equivalents. At the commencement of a cruise the water bottles were cleaned by filling with a solution of the detergent Deacon 90. Samples for analysis of mercury were drawn into 500 ml Pyrex vessels and acidified to pH 1 with nitric acid (Merck 457), containing less than 0.05 nmol/l mercury impurities. The Pyrex bottles were precleaned with both nitric acid and a solution of nitric and hydrofluoric acids (10:1), and subsequently stored up to the time of sampling holding a small volume of nitric acid. Ashore, reactive mercury was determined by cold vapour atomic absorption after preconcentration by amalgamation on gold [66]. The total mercury concentration was similar to that obtained using a 500 W low-pressure mercury lamp (Hanovia) and immersion irradiation equipment. The precision of the mercury determination assessed by analysing 19 replicates over a period of 107 d was found to be ± 2.0 pmol/l for a concentration of 12.5 pmol/l.

1.3.2

Losses of Phthalic Acid Esters and Polychlorinated Biphenyls from Seawater Samples During Storage

During the storage of the sample, loss of analyte can occur via vaporisation, degradation, and/or adsorption. Adsorption of trace organic and inorganic species in seawater to container walls can severely affect the accuracy of their determination. The adsorption of dichlorodiphenyltrichloroethylene [67] and hexachlorobiphenyl [68] onto glass containers has been observed.

Sullivan et al. [69] studied the loss of phthalic acid esters and chlorinated biphenyls from seawater whilst stored in glass containers. Equilibrium was essentially reached in 12 h at 25 °C. Labelled compounds were used in some of the studies. Table 1.10 shows that between 2.2 and 49.9% of the organic solutes were lost from the spiked solutions.

Table 1.10. Distribution of solutes among original solutions and subsequent water and solvent rinses of containers [69]

Solute	Initial aqueous concentration ($\mu\text{g/l}$)	Percentage of solute recovered		
		Original spiked water	Water rinses of test tubes	Acetonitrile rinses of test tubes
DBP	4420 (140)	94.6	ND	5.4
		85.4	ND	14.6
^{14}C DBP	28.9 (2.2)	95.8	4.1	< 0.1
		97.0	2.9	< 0.1
^{14}C DBP	19.2 (2.0)	96.2	3.6	< 0.1
		97.8	2.1	0.1
BEHP	407 (± 9)	68.0	20.5	11.4
		72.1	19.5	8.4
		74.1	17.5	8.4
BEHP	229 (± 7)	56.2	3.1	40.7
		73.0	2.0	25.0
		54.6	30.4	15.0
^{14}C BEHP	15.5 (± 0.3)	56.0	27.8	16.2
		50.1	21.2	18.7
		54.6	30.4	15.0
^{14}C PCB (alone)	6.8 (± 0.5)	71.1	5.5	23.4
		81.1	0.6	18.3
		55.2	11.4	33.4
^{14}C PCB (after BEHP)	6.8 (± 0.5)	55.3	4.4	40.3

DBP = Dibutyl phthalate; BEHP = Bis (2-ethylhexyl) phthalate; PCB = Polychlorinated biphenyls; ND = Not done

The absorbed compounds were only partially recovered by subsequent water rinses. A solvent rinse of the containers recovered the remainder of the compounds adsorbed to the surface.

The amount of phthalate bound to the glass test tubes appears to be a function of the aqueous solubility of the phthalate. The solubilities of the phthalates have been reported to be 3.2 mg dibutyl phthalate and 1.2 mg *bis* (2-ethylhexyl) phthalate per litre of artificial seawater [70]. Table 1.10 shows that the more soluble dibutyl phthalate is absorbed far less than *bis* (2-ethylhexyl) phthalate.

The amount of solute also appears to be altered by the presence of other material already on the surface. Between 70% and 80% of the total polychlorinated biphenyls stayed in the aqueous phase when *bis* (2-ethylhexyl) phthalate was not present. When approximately 400 ng *bis* (2-ethylhexyl) phthalate was absorbed to each test tube, only 55% of the total polychlorinated biphenyls stayed in the aqueous phase. The increased lipophilicity due to the presence of *bis* (2-ethylhexyl) phthalate apparently increased the adsorption of polychlorinated biphenyl by the glass test tubes.

The significant percentage of these organic pollutants in the unspiked water rinses indicates that their adsorption is reversible. Once the compounds are adsorbed to the glass, they can desorb into the next solution that is placed into the container, which is a concern during repeated use of the same storage or sampling container. The cross-contamination of samples and the loss of the analyte can be reduced by rinsing the container with clean water or solvent which is then processed with the sample, or by extracting the sample in the container.

1.4

Sample Contamination During Analysis

The environment in which samples are collected and processed during an oceanographic cruise would be considered unacceptable by any non-oceanographic microanalysis laboratory. On even the best-planned oceanographic vessels the space in which the samples are taken, the winch room and the wet lab, are normally awash in seawater, with a thin film of oil over most of the exposed surfaces. The worst case is to be found where the wet lab and winch room are combined, or where the wet lab is the natural passageway between important parts of the ship, such as the engine room and the galley. These circumstances are the rule rather than the exception on oceanographic vessels, even on those planned from scratch for oceanographic research. The reasons for these apparent flaws in planning are historical: chemical oceanographers were interested either in major components of seawater or in trace nutrients, and neither of these kinds of analyses would be seriously damaged by the contamination to be found in such wet labs.

With the recent emphasis upon the analysis of trace metals and organic materials, particularly possible pollutants, it has become obvious that cleaner working areas are necessary. The winch room, with its assorted greases and oils,

must be separated from the sampling room, and ideally the people working on the hydrographic wire, handling the samplers, should not also be drawing the samples. The samplers should come into the sampling room through a hatch which can be closed. The sampling room should be a dead-end room, not a throughway, to discourage visitors. It would be unrealistic to expect a wet lab to be as free of contamination as a clean room, but it should approach the clean room in general arrangements. Even the air entering the sampling area should be cleaned of hydrocarbons, perhaps by filtration through charcoal. The all-pervasive smell of diesel fuel in most oceanographic vessels does not bode well for the accuracy of any analyses for petroleum hydrocarbons.

If the analyses are to be performed on board, the room in which the samples are prepared and analysed should, in fact, be built as a clean room. Many modern oceanographic vessels are constructed to accept modular laboratories, which can be removed between voyages. Clean room modules, complete with air conditioning and filtered air supply, have been built for several vessels. It is possible to perform accurate, precise microanalyses on board ship under less favourable conditions, but the analyst is really fighting the odds.

If the samples are to be brought back to a shore laboratory for analysis, contamination during analysis is more easily controlled. The analyst on shore must have confidence in the people taking the samples: with the pressure on berth space and wire time on board ship, too often the samples are taken on a “while you’re out there, take some for me” basis. Again, ideally, the analyst should at least oversee every part of the process, from the cleaning of the sampler to the final calculation of the amounts present. His confidence in the accuracy of the final calculation must decrease as he departs from the ideal arrangement.

In the shore laboratory, the samples must be handled with the care needed for any trace analysis. It must be remembered that the total amount of organic carbon in seawater is around 1 ppm; single compounds are likely to be present at ppb levels. In order to collect enough material even for positive identification of some of the compounds present, the materials must often be concentrated.

Analytical chemists have long been aware of the necessity for purification of any organic solvents used in trace analysis. The advent of gas and liquid-liquid chromatography has made plain just how many impurities can hide behind a “high purity” label. Redistillation of organic solvents just before use is commonplace in most analytical laboratories. What has not been so evident is the amount of organic material to be found in most inorganic reagents. The actual amount present, let us say, in reagent grade sodium chloride may be low enough so that it is not listed on the label, but still high enough to produce an artificial seawater containing more organic carbon than the real thing. The presence of these compounds becomes serious when the analyst wishes to concoct artificial seawater for standards and blanks. If the chemical in question can withstand oxidation, either at high temperature or in the presence of active oxygen, the organic material may be eliminated. However, many compounds

used in routine analysis cannot be treated in this manner. If such chemicals must be used, the calculation of a true methods blank can become a major analytical problem.

Another problem, equally unrecognised, is the organic content of the distilled water. For most analytical procedures, simple distillation is insufficient treatment; perhaps in special cases, such extremes as distillation from permanganate or distillation in quartz is considered necessary. For the analysis of organic materials at the ppm level in aqueous solutions, these methods are far from sufficient. The experience of many workers has been that no form of chemical pre-treatment will remove all of the organic material from distilled water, and that some form of high-temperature oxidation of the impurities in the water must be used [71–73]. Depending upon the original source of the water, normal distillation will leave between 0.25 and 0.6 mg carbon/litre in the distillate. The amounts and the kinds of compounds may vary with the seasons and with the dominant phytoplankton species in the reservoirs. Since ocean water taken from depths greater than 500 m will usually contain only 0.3–0.7 mg carbon/litre, it can be seen that the purity of the distilled water used to make up reagents can be quite important. Sub-boiling distillation of deep seawater might be an efficient starting point for the production of carbon-free blanks.

While at least partial solutions have been found to most of the problems of contamination, these solutions have largely been adopted piecemeal by the various laboratories engaged in research on organic materials in seawater. The reasons for the adoption of half-way measures are largely historical. The study of organic materials in seawater is relatively new, and the realisation that draconian measures are needed in the analysis is now becoming accepted.

The problems that can be encountered in sampling, sample preservation, and analysis have been discussed by King [74], Grice et al. [75] (sampling); Bridie et al. [76] (non-hydrocarbon interference); Farrington [77] (hydrocarbon analysis); Kaplin and Poskrebysheva [78] (organic impurities); Hume [79], Riley [80] (oceanographic analysis); Acheson et al. [81] (polynuclear hydrocarbons); Giam and Chan [82] (phthalates); Giam et al. [83] (organic pollutants); and Grasshoff [84, 85] (phosphates).

Mart [86] has described typical sample bottle cleaning routine for use when taking samples for very low level metal determinations.

Sampling bottles and plastic bags, both made of high-pressure polyethylene, were rinsed by the following procedure. First clean with detergent in a laboratory washing machine, rinse with deionised water, soak in hot (about 60 °C) acid bath, beginning with 20% hydrochloric acid, reagent grade, followed by two further acid baths of lower concentrations, the latter being from Merck (Suprapur quality or equivalent). The bottles are then filled with dilute hydrochloric acid (Merck, Suprapur), this operation being carried out on a clean bench, rinsed and then filled with very pure water (pH 2). Bottles are wrapped into two polyethylene bags. For transportation purposes, lots of ten bottles are enclosed hermetically in a large bag.

The determination of traces of heavy metals in natural waters can be greatly affected by contamination (positive and negative) during filtration and storage of samples [87–92]. Until the recent work of Scarponi et al. [93], this problem, especially as regards filtration, had not been studied adequately and systematically with respect to the determination of cadmium, lead, and copper in seawater. Frequently, in order to make the determination easier, synthetic matrix samples [92–94] and/or high metal concentrations [92–96] have been used; otherwise, in order to demonstrate possible filter contamination, washed and unwashed filters have been analysed after washing [97–103].

The same filter can release or absorb trace metals depending on the metal concentration level and the main constituents of the sample [92, 104], so the results claimed must be considered with caution in working with natural samples. To avoid contamination, the following procedures have often been used. Filters have been cleaned by soaking them in acids [88–90, 100, 103–107] or complexing agents [87, 88, 101] and/or conditioned either by soaking in seawater or a simulated seawater solution [10, 104, 108] or by passing a 0.2–2 l sample before aliquots are taken for analysis [88, 90, 103, 109, 110]. Sometimes, however, the washing procedure has not been found to be fully satisfactory [87]. For example, it has been reported that strong adsorption of cadmium and lead occurs on purified unconditioned membrane filters when triple-distilled water is passed through the filter, whilst there is no change in the concentration with a river water sample after filtration of 500 ml [104]. Some investigators prefer to avoid filtration when the particulate matter does not interfere with the determination (in which case the analysis must be completed soon after sampling) [103, 111] or when open seawater is analysed. In the latter case, filtered and unfiltered samples do not seem to differ significantly in measurable metal content [103, 112, 113].

The optimal conditions for uncontaminated long-term storage of dilute heavy metal solutions, particularly seawater, are now a topic of great interest. and contradictory results have frequently been reported. For example, with regard to the type of material to be used for the container, some workers have recommended the use of linear (high density) polyethylene instead of conventional (low density) polyethylene [90, 114–116], while others have reported that linear polyethylene is totally unsuitable or inferior to low-density polyethylene [87, 89, 117–119]. Moreover, as a general rule, findings for particular conditions are not necessarily applicable to elements, concentrations, matrices, containers, or experimental conditions different from those tested. As the macro and micro constituents of natural waters can differ widely [120], extreme caution must be used in handling published results. Possibly, as recommended [88, 90, 121], it is best to ascertain the effectiveness of the storage system adopted in one's own laboratory.

Scarponi et al. [93] used anodic stripping voltammetry to investigate the contamination of seawater by cadmium, lead, and copper during filtration and storage of samples collected near an industrial area. Filtration was carried

out under clean nitrogen to avoid sample contamination. Seawater leaches metals from unclean membrane filters but, after one litre of water has passed through, the contamination becomes negligible. Samples stored in conventional polyethylene containers (properly cleaned and conditioned with pre-filtered seawater) at 4 °C and natural pH remain uncontaminated for three months (five months for cadmium); losses of lead and copper occur after five months storage. Reproducibility (95% confidence interval) was 8–10%, 3–8% and 5–6% at concentration levels of about 0.06, 2.5, and 6.0 µg/l, for cadmium, lead, and copper, respectively.

The first aim of this work was to study the influence of an unwashed membrane filter on the cadmium, lead, and copper concentrations of filtered seawater samples. It was also desirable to ascertain whether, after passage of a reasonable quantity of water, the filter itself could be assumed to be clean so that subsequent portions of filtrate would be uncontaminated. If this were the case, it should be possible to eliminate the cleaning procedure and its contamination risks. The second purpose of the work was to test the possibility of long-term storage of samples at their natural pH (about 8) at 4 °C, kept in low-density polyethylene containers which have been cleaned with acid and conditioned with seawater.

Before use, new containers were cleaned by soaking in 2 M hydrochloric acid for four days and conditioned with prefiltered seawater for a week, all at room temperature [90, 104]. Teflon-covered stirring bars (required for the voltammetric measurements) were introduced into the containers at the beginning of the cleaning procedure. The containers used in another procedure and in the study of long-term storage could be regarded as having been conditioned for about one month and more than two months, respectively. Other plastics used in the sampling and filtration processes, and the components of the voltammetric cell that came in contact with the sample solution, underwent the same procedure as the containers.

Figure 1.4 shows a typical curve demonstrating the dependence of concentrations of copper, lead, and cadmium in the filtrate on the volume of seawater sampled. Metal levels become constant after 1–1.5 l of sample have been filtered, and it can be concluded that at this point, contamination of the sample by the filtration equipment is negligible.

Table 1.11 gives the results of analytical measurements on aliquots of a conditioning seawater stock, stored at about 4 °C for three and five months in old low-density polyethylene containers (acid-washed for four days and conditioned for more than two months).

Apart from the observation that the concentrations are generally higher than those measured previously, which indicates contamination during conditioning and manipulation, and the necessity of frequently renewing seawater for equilibration purposes, it can be seen that there are no changes in the metal concentrations for three months for lead and copper, or for five months for cadmium. Also, after five months storage, some loss of lead and

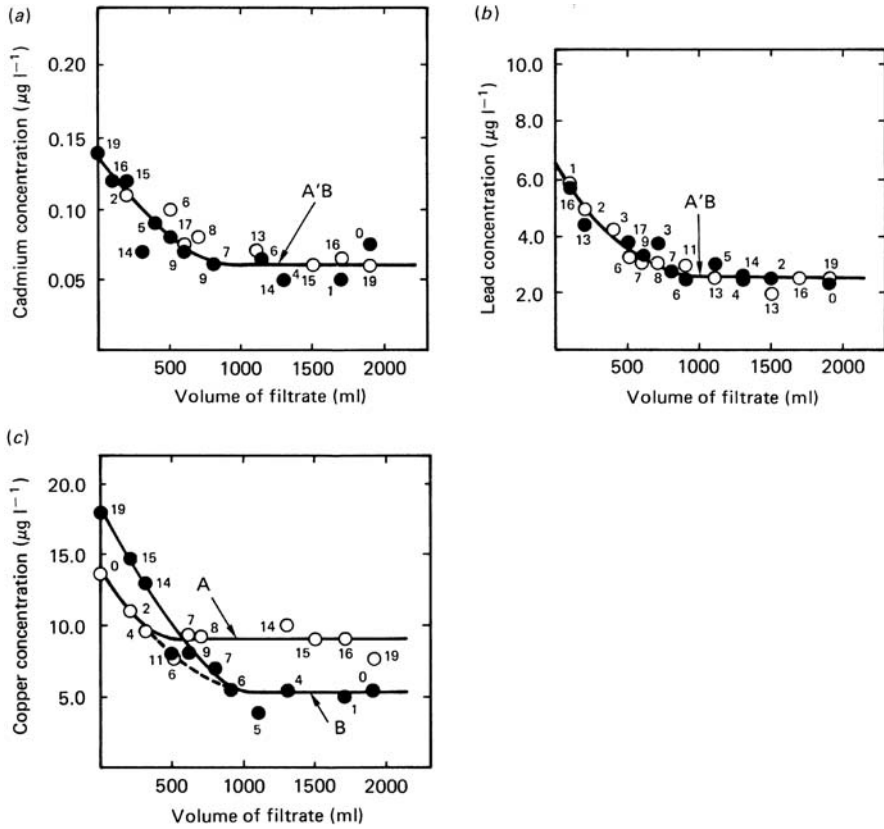

Figure 1.4. Concentration dependences on filtrate volume by procedure 1: (a) Cd; (b) Pb; (c) Cu. Numbers refer to storage time in days. ● measured in order of sampling; ○ measured in reverse order of sampling. From [93]

copper (21% and 24%, respectively), can be observed, possibly because of the formation and slow adsorption on container surfaces of hydroxo- and carbonato-complexes [90, 122]. Hence at 4 °C in polyethylene containers no significant changes of heavy metal concentrations occur over a three-month period [105, 110, 123].

Scarponi et al. [93] concluded that filtration of seawater through uncleaned membrane filters shows positive contamination by cadmium, lead, and copper. In the first filtrate fractions, the trace metal concentration maybe increased by a factor of two or three. During filtration, the soluble impurities are leached from the filter, which is progressively cleaned, and the metal concentration in the filtrate, after passage of 0.8–1 l of seawater, reaches a stable minimum value. Thus it is recommended that at least one litre of seawater at natural pH be passed through uncleaned filters before aliquots for analysis are taken

Table 1.11. Results after of long-term storage [93]

Date (1979)	Storage time (months)	Metal concentration ($\mu\text{g/l}$)								
		Cadmium			Lead			Copper		
		Conc.	Mean	Change (%)	Conc.	Mean	Change (%)	Conc.	Mean	Change (%)
July 2	0	0.16	0.17		4.0,	4.2		7.7,	8.0	
		0.19			4.3			8.0		
		0.17			4.3,			8.4,		
		0.16			4.2			8.0		
Sept 30	3	0.15	0.16	- 6	5.0,	4.1	- 2	7.8,	7.8	- 2.5
		0.16			3.6			7.5		
		0.16			4.2,			8.1		
		0.18			3.6					
Nov 28th	5	0.18	0.17	0	3.7,	3.3	- 21	5.9,	6.05	- 24
		0.18			3.1			5.8		
		0.16			2.6,			6.5,		
					3.8			6.0		

from the subsequent filtrate. The same filter can be reused several times, and then only the first 50–100 ml filtrate need be discarded. This system seems simpler and more reliable for avoiding contamination than that of washing and conditioning filters before use, especially since in the latter case it has been suggested that the first 0.2–2.0 l of filtrate should also be discarded.

Low-density polyethylene containers are suitable for storing seawater samples at 4 °C and natural pH, provided that they are thoroughly cleaned (in 2 M hydrochloric acid for at least a week) and adequately conditioned (with prefiltered seawater for at least one to two weeks). Storage can be prolonged for at least three months (or five months for cadmium) without significant concentration changes. For lead and copper, adsorption losses are observed after five months.

The use of a special device that allows filtration under nitrogen, the direct introduction of sample into containers for storage during filtration and, the use of these containers as analysis cells are all improvements that minimise external sample contamination and improve between-sample reproducibility.

Degobbi [60] studied the storage of seawater samples for ammonia determination. The effects of freezing, filtration, addition of preservatives, and type of container on the concentration of ammonium ions in samples stored for up to a few weeks were investigated. Both rapid and slow freezing were equally effective in stabilising ammonium ion concentration, and the addition of phenol as a preservative was effective in stabilising non-frozen samples for up to two weeks.

References

1. Ashton A, Chan R (1987) *Analyst* **112**:841
2. Schuessler U, Kremling K (1993) *Deep-Sea Res Part 1* **40**:257
3. Dunn J, Hall CD, Heath MR, Mitchell RB, Ritchie BJ (1993) *Deep-Sea Res Part 1* **40**:867
4. Teasdale P, Batley GE, Apte SC, Webster IT (1995) *Trends Anal Chem* **14**:250
5. Bufflap SE, Allen HE (1995) *Water Res* **29**:2051
6. Yamamoto M, Urata K, Murashige K, Yamamoto Y (1981) *Spectrochim Acta B* **36**:671
7. Green DR (1977) *Committee of Marine Analytical Chemistry*, Canada Centre for Inland Waters, Fisheries and Environment, Ottawa, Canada
8. Wangersky PJ (1976) *Ann Rev Ecol Sys* **7**:161
9. Wangersky PJ (1976) *Deep-Sea Res* **23**:457
10. Gordon Jr., DC, Keizer PD (1974) *Technical Report No. 481* Fisheries Research Board, Canada
11. Harvey GW (1966) *Limnol Oceanogr* **11**:608
12. Garrett WD (1965) *Limnol Oceanogr* **10**:602
13. Daumas RA, Laborde PL, Marty JC, Saliot A (1976) *Limnol Oceanogr* **319**:319
14. Harvey GW, Burzell LA (1972) *Limnol Oceanogr* **19**:156
15. Garrett WD, Burger R (1974) *Sampling and determining the concentration of film-forming organic constituents of the air-water interface*, US NRL Memo Report 2852
16. Larsson K, Odham G, Sodergren A (1974) *Mar Chem* **2**:49
17. Miget R, Kator H, Oppenheimer C (1974) *Anal Chem* **45**:1154
18. Anufrieva NM, Gornitsky AB, Nesterova MP, Neirovskaya IA (1976) *Okeanologiya* **16**:255
19. Baier RE (1972) *J Geophys Res* **77**:5062
20. Gump BH, Hertz HA, May WE, Chesler SN, Dyszel SM, Enagnio DP (1975) *Anal. Chem* **47**:1223
21. Keizer PD, Gordon DC, Jr., Dale J (1977) *Journal of the Fisheries Research Board* **34**:37
22. Clark Jr., RC, Blumer M, Raymond SO (1967) *Deep-Sea Res* **14**:125
23. Bertoni R, Melchiorri-Santolini U (1972) *Mem Inst Ital Hydrobiol* **29**:97
24. Gordon Jr., DC, Keizer PD, Dale J (1974) *Mar Chem* **251**:251
25. Smith KL (1971) *Limnol Oceanogr* **16**:675
26. Bewers JM, Dalziel J, Yeats PA, Barron JL (1981) *Mar Chem* **10**:173
27. Olafsson J (1978) *Mar Chem* **87**:87
28. Olafsson J (1980) *A preliminary report on ICES intercalibration of mercury in seawater for the joint monitoring group of the Oslo and Paris commissions*, submitted to the Marine Chemistry Working Group of OCS, February 1980
29. Thibaud Y (1980) *Exercice d'Intercalibration CIEM, 1979, Cadmium en eau de mer*, report submitted to the Marine Chemistry Working Group of ICES
30. Jones PGW (1977) *A preliminary report on the ICES intercalibration of sea water samples for the analyses of trace metals*, ICES CM1977/E:16
31. Jones PGW, (1976) *An ICES intercalibration exercise for trace metal standard solutions*, ICES CM1979/E:15
32. Windom HL (1979) *Report on the Results of the ICES Questionnaire on Sampling and Analysis of Water for Trace Elements*, Submitted to the First Meeting of the Marine Chemistry Working Group, Lisbon
33. Pocklington R (1972) *Variability of Ocean off Bermuda*, Bedford Institute of Oceanography Report Series BI-R-72-73
34. Boyle EA, Sclater FR, Edmond JM (1977) *Sci Lett* **37**:38
35. Bruland KW, Knauer GA, Martin JH (1978) *Limnol Oceanogr* **23**:618

36. Bruland KW, Knauer GA, Martin JH (1978) *Nature* 271:741
37. Sclater FR, Boyle EA, Edmond JM (1976) *Earth Planet Sci Lett* 31:119
38. Wong CS, Kremling K, Riley JP et al. (1985) Ocean Chemistry Division Institute of Ocean Sciences, PO Box 6000, Sidney, BC, V8L 4B2, Canada. Ocean Chemistry Division contract to SEAKEM Oceanography Ltd., Sidney, BC, Canada. Marine Chemistry Department, Institut für Meereskunde und der Universität, Kiel, Dunsternbrooker Weg 20, 2300 Kiel, FR Germany. Department of Oceanography, University of Liverpool, PO Box 147, Liverpool, L69 3BX, UK
39. Patterson CC, Settle M (1976) The reduction of orders of magnitude errors in lead analysis. In: LaFleur PD (ed) *Accuracy in trace analysis: sampling, sample handling, analysis*. NBS Special Publication 422, p. 321
40. Bothner MH, Robertson DE (1975) *Anal Chem* 47:592
41. Participants in IDOE Workshop (1976) *Mar Chem* 4:389
42. Stukas VJ, Wong CD (1976) *Science* 211:1424
43. Wong CS, Kremling K, Riley JP et al. (1979) *Accurate Measurement of Trace Metals in Sea Water: an Intercomparison of Sampling Devices and Analytical Techniques using CEPEX Enclosure of Sea Water*. Unpublished manuscript report, NATO study funded by NATO Scientific Affairs Division
44. Abdullah MI, El-Rayis OA, Riley JP (1976) *Anal Chim Acta* 84:363
45. Abdullah MI, Royale LG (1972) *Anal Chim Acta* 80:58
46. Danielsson LG, Magnusson B, Westerlund S (1978) *Anal Chim Acta* 98:47
47. Otsuki A, Hanya T (1972) *Limnol Oceanogr* 87:248
48. Jannasch NW, Pritchard PH (1972) *Mem Inst Ital Hydrobiol* 24 Suppl:289
49. Wiebe WS, Pomeroy LR (1972) *Mem Inst Ital Hydrobiol* 29 Suppl:325
50. Alburn HE, Grant NH (1965) *J Am Chem Soc* 87:4174
51. Grant NH, Alburn HE (1965) *Biochemistry* 4:1913
52. Grant NH, Alburn HE (1967) *Arch Biochem Biophys* 118:292
53. Yoshinari I (1976) *Mar Chem* 4:189
54. Masee R, Maessen FJMJ (1981) *Anal Chim Acta* 127:181
55. Florence TM, Bailey GM (1980) *CRC Critical Reviews on Analytical Chemistry* August:219
56. Karin RW, Buone JA, Fashing JL (1975) *Anal Chem* 47:2296
57. Robertson DE (1968) *Anal Chim Acta* 42:533
58. Pellenburg RE, Church TM (1978) *Anal Chim Acta* 97:81
59. Flegal A, Stukas V (1987) *J Mar Chem* 22:163
60. Degobbis D (1973) *Limnol Oceanogr* 18:146
61. Coyne R, Collins JA (1972) *Anal Chem* 44:1093
62. Carr RA, Wilkniss PE (1973) *Environ Sci Technol* 7:62
63. Feldman C (1974) *Anal Chem* 46:99
64. Fitzgerald WF (1979) Distribution of mercury in natural waters. In: Nriagu JO (ed) *The Biogeochemistry of Mercury in the Environment*. Elsevier, Amsterdam, The Netherlands
65. Olafsson J (1981) Trace Metals in Seawater. In: Wong CS et al. (eds) *Proceedings of a NATO Advanced Research Institute on Trace Metals in Seawater*, 30/3-3/4/81, Sicily, Italy. Plenum Press, New York, NY, USA
66. Olafsson J (1974) *Anal Chim Acta* 68:207
67. Picer M, Picer N, Strohal P (1977) *Sci Total Environ* 8:159
68. Pepe HG, Byrne JJ (1980) *Bull Environ Contam Toxicol* 25:936
69. Sullivan KR, Altas EL, Giam CS (1981) *Anal Chem* 53:718
70. Kakreka JPMS (1974) *Thesis*, Texas A&M University, USA

71. Wangersky PJ (1965) *American Science* **53**:358
72. Hickman K, White I, Stark E (1973) *Science* **180**:15
73. Conway BE, Angerstein-Kozłowska H, Sharp WBA (1973) *Anal Chem* **45**:1331
74. King DL, Ciaccio LL (1971) (eds) *Sampling of Natural Waters and Waste Effluents*, Marcel Dekker, New York, NY, USA, p. 451
75. Grice GD, Harvey GR, Bown VT, Backus RH (1972) *Bull Environ Contam Toxicol* **7**:125
76. Bridie AL, Box J, Herzberg S (1973) *J Inst Petrol* **59**:263
77. Farrington JW (1974) *AD Report No. 777695/GA*, US National Technical Information Service
78. Kaplin AA, Poskrebysheva LM (1974) *Izvestia Tomsk Politekhn Inst* **233**:91
79. Hume DN (1975) Fundamental problems in oceanographic analysis. In: Gibb, Jr., RP (ed) *Analytical Methods in Oceanography*. ACS, Washington, DC, USA, p. 1
80. Riley JP (1975). In: Riley JP, Skirrow G (eds) *Chemical Oceanography, Volume 3*. Academic Press, London, UK, p. 193
81. Acheson MA, Harrison RM, Perry R, Wellings RA (1976) *Water Res* **10**:207
82. Giam CS, Chan HS (1976) *Special Publication*, National Bureau Standards (US), No. 422, p. 761
83. Giam CS, Chan HS, Neff GS (1976) In: *Proceedings of International Conference Environmental Sensing Assessment* ACS, Washington, DC, USA
84. Grasshoff K (1966) *Anal Chem* **220**:89
85. Grasshoff K (1976) *Verlag Chemie* **1**:50
86. Mart L (1979) *Fresen Z Anal Chem* **296**:350
87. Robertson DE (1972) In: *Ultrapurity Methods and Techniques*, Zeif M, Speights R (eds). Marcel Dekker, New York, NY, USA, p. 207
88. Riley JP, Robertson DE, Dutton JWR et al. (1975). In: Riley JP, Skirrow G (eds) *Chemical Oceanography, 2nd Edition, Volume 3*. Academic Press, London, UK, p. 193
89. Zief M, Mitchell JW (1976) *Contamination Control in Trace Element Analysis*, Wiley New York, NY, USA
90. Batley GE, Gardner D (1977) *Water Res* **11**:745
91. Salim R, Cooksey G (1980) *J Electroanal Chem* **106**:251
92. Truitt RE, Weber JH (1979) *Anal Chem* **51**:2057
93. Scarponi G, Capodaglio G, Cescon P, Cosma B, Frache R (1982) *Anal Chim Acta* **135**:263
94. Weber JH, Truitt RE (1979) *Research Report 21*, Water Resource Research Center, University of New Hampshire, Durham, NH, USA
95. Marvin KT, Proctor, Jr., RR, Neal RA (1970) *Limnol Oceanogr* **15**:320
96. Gardiner J (1974) *Water Res* **8**:157
97. Spencer DW, Manheim FT (1969) *US Geological Survey Professional Paper, 650-D*, p. 288
98. Spencer DW, Brewer P, Sachs PL (1972) *Geochim Cosmochim Acta* **36**:71
99. Dams R, Rahn KA, Winchester JW (1972) *Environ Sci Technol* **6**:441
100. Wallace, Jr., GT, Fletcher IS, Duce RA (1977) *J Environ Sci Health* **A12**:493
101. Duychserts G, Gillain G (1977). In: (ed Wanninen W) *Essays on Analytical Chemistry* Pergamon, Oxford, UK, p. 417
102. Smith RG (1978) *Talanta* **25**:173
103. Mart L (1979) *Fresen Z Anal Chem* **296**:352
104. Nurnberg HW, Valenta P, Mart L, Raspor B, Sipos L (1976) *Fresen Z Anal Chem* **282**:357
105. Batley GE, Gardner D (1978) *Estuar Coast Mar Sci* **7**:59
106. Bruland KW, Franks RP, Knauer GA (1979) *Anal Chim Acta* **105**:233
107. Burrell DC (1979) *Mar Sci Comm* **5**:283
108. Figura P, McDuffie B (1980) *Anal Chem* **52**:1433

109. Burrell DC, Lee ML (1975) *Water Quality Parameters, ASTM STP-573*, ASTM, p. 58
110. Fukai R, Huynh-Ngoc L (1976) *Mar Pollut Bull* 7:9
111. DeForest A, Pettis RW, Fabris G (1978) *Australian Journal of Marine and Freshwater Research* 29:193
112. Fukai R, Huynh-Ngoc, L (1976) *Anal Chim Acta* 83:375
113. Zirino A, Lieberman SH, Clavell C (1978) *Environ Sci Technol* 12:73
114. Gardiner J, Stiff MJ (1975) *Water Res* 9:517
115. Bowen VT, Strohal P, Saiki M et al. (1970) In: *Reference Methods for Marine Radioactivity Studies* (eds) Nishiwaki Y, Fukai R, International Atomic Energy Agency, Vienna, Austria, p. 12
116. Bowditch DC, Edmond CR, Dunstan PJ, McGlynn J (1976) *Technical Paper No. 16*, Australian Water Resources Council, p. 22
117. Tolg G (1972) *Talanta* 19:1489
118. Tolg G (1975). In: (ed) Svehia G. *Comprehensive Analytical Chemistry, Volume 3* Elsevier, Amsterdam, The Netherlands
119. Moody JR, Lindstrom RM (1977) *Anal Chem* 49:2264
120. Davison W, Whitfield M (1977) *J Electroanal Chem* 75:763
121. Scarponi G, Miccoli E, Frache R (1978). In: *Proceedings of the 3rd Congress of the Association of Italian Oceanology and Limnology*, Sorrento, Italy. Pergamon Press, Oxford, UK, p. 433
122. Subramanian KS, Chakrabati CL, Sheiras JE, Maines IS (1978) *Anal Chem* 50:444
123. Carpenter JH, Bradford WL, Grant V (1975) In: (ed) Cronin LE. *Estuarine Research* Academic Press, New York, NY, USA, p. 188

2 Determination of Anions

2.1

Acetate

2.1.1

Ion Chromatography

Xiao-Hua Yang et al. [1] determined nanomolar concentrations of individual low molecular weight carboxylic acids (and amines) in seawater. Diffusion of the acids across a hydrophobic membrane was used to concentrate and separate carboxylic acids from inorganic salts and most other organic compounds prior to the application of ion chromatography. Acetic propionic acid, butyric-1 acid, butyric-2 acid, valeric and pyruvic acid, acrylic acid and benzoic acid were all found in reasonable concentrations in seawater.

2.2

Acrylate

2.2.1

Ion Chromatography

See Sect. 2.1.1.

2.3

Alkalinity

2.3.1

Titration Method

Among the possible analytical methods for alkalinity determination, Gran-type potentiometric titration [2] combined with a curve-fitting algorithm is considered a suitable method in seawaters because it does not require a priori knowledge of thermodynamic parameters such as activity coefficients and dissociation constants, which must be known when other analytical methods for alkalinity determination are applied [3–6].

Alkalinity determination in hypersaline solutions by Gran-type titration is subject to a number of errors which can usually be neglected in lower ionic strength solutions. For example, the pH readings along the titration path may be inaccurate due to the marked difference between the ionic strength and composition of the sample and the standard buffers used to calibrate the glass and reference electrode pair [7].

Ben Yaakov and Lorch [8] identified the possible error sources encountered during an alkalinity determination in brines by a Gran-type titration and determined the possible effects of these errors on the accuracy of the measured alkalinity. Special attention was paid to errors due to possible non-ideal behaviour of the glass-reference electrode pair in brine. The conclusions of the theoretical error analysis were then used to develop a titration procedure and an associated algorithm which may simplify alkalinity determination in highly saline solutions by overcoming problems due to non-ideal behaviour and instability of commercial pH electrodes.

The titration procedure used was that described by Ben Yaakov et al. [9], in which 100 ml of seawater or brine sample is titrated in 30–50 burette increments with 3–5 ml standard 0.1 M hydrochloric acid using a pH electrode.

The accuracy of the method was tested experimentally by running duplicate titrations on distilled water, artificial seawater with and without sulfate, and artificial Dead Sea waters. For each run, alkalinity was calculated by two methods:

1. by the conventional Gran plot, which presumes that the glass electrode is properly calibrated;
2. by the method that applies the titration data for in situ calibration of the glass electrode via the slope correction algorithm.

The precision of the latter method when applied in the distilled water runs was found to be significantly better than the conventional method. This could be attributed to the non-stability of the glass electrode, which is corrected for by the proposed algorithm.

2.3.2

Spectrophotometric Methods

Various workers have discussed the determination of total alkalinity and carbonate [10–12], and the carbonate:bicarbonate ratio [12] in seawater. A typical method utilises an autoanalyser. Total alkalinity (T: milliequivalents per litre) is found by adding a known (excess) amount of hydrochloric acid and back titrating with sodium hydroxide solution; a pH meter records directly and after differentiation is used to indicate the end-point. Total carbon dioxide (C: milliequivalents per litre of HCO_3^- per litre) is determined by mixing the sample with dilute sulfuric acid and segmenting it with carbon dioxide-free air, so that the carbon dioxide in the sample is expelled into the air segments. The air

is then separated from the sample and passed into buffered phenolphthalein solution, thereby lowering the pH and diminishing the colour of the phenolphthalein. The reduction in colour is measured colorimetrically (540 nm). The concentration of carbonate is given by $2(T-C)$ milliequivalents per litre, and the concentration of bicarbonate is $2C-T$ milliequivalents per litre.

A computer program has been used to calculate the magnitude of systematic errors incurred in the evaluation of equivalence points in hydrochloric acid titrations of total alkalinity and carbonate in seawater by means of Gran plots. Hansson [13] devised a modification of the Gran procedure that gives improved accuracy and precision. The procedure requires approximate knowledge of all stability constants in the titration.

2.4

Arsenate/Arsenite

2.4.1

Spectrophotometric Method

Haywood and Riley [14] have described a spectrophotometric method for the determination of arsenic in seawater. Adsorption colloid flotation has been employed to separate phosphate and arsenate from seawater [15]. These two anions, in 500 ml filtered seawater, are brought to the surface in less than 5 min, by use of ferric hydroxide (added as 0.1 M FeCl_2 ; 2 ml) as collector, at pH 4, in the presence of sodium dodecyl sulfate [added as 0.05% ethanolic solution (4 ml)] and a stream of nitrogen (15 ml/minutes). The foam is then removed and phosphate and arsenate are determined spectrophotometrically [16]. Recoveries of arsenate and arsenite exceeding 90% were obtained by this procedure.

2.5

Benzoate

2.5.1

Ion Chromatography

See Sect. 2.1.1.

2.6

Butyrate

2.6.1

Ion Chromatography

See Sect. 2.1.1.

2.7

Borate

2.7.1

Spectrophotometric Method

Sato [17] has examined several α -hydroxy acids as complexing agents for the extraction-spectrophotometric determination of boron. Mandelic acid is the most useful. The boron-complex anion obtained is extracted into benzene with malachite green in a single extraction; boron is determined indirectly by measuring the absorbance of malachite green in the extract at 633 nm. The calibration graph is linear over the range $7.50 \times 10^{-7} - 1.50 \times 10^{-5}$ mol/l boron; the apparent molar absorptivity is 6.52×10^4 l/mol/cm. The method is applied to the determination of micro amounts of boron in waters with satisfactory results.

2.8

Bromate

2.8.1

Spectrophotometric Titration and Differential Pulse Polarography

Chlorinated waters are being discharged to estuaries and coastal waters in increasing quantities. In such systems the chlorine reacts with the natural bromide and ammonia at pH 8 to produce the highly toxic hypobromous acid, hypobromite ion, and haloamines. For normal seawater of pH 8, the initial products of chlorination are a mixture of hypobromous acid and the hypobromite ion. Both of these compounds are unstable with respect to decomposition and disproportionation.

Macalady et al. [18] report experiments in which chlorinated sea water was exposed to sunlight at various intensities, to simulate different periods of the day. The results of subsequent analyses for bromates and residual oxidants show that the rate and extent of bromate formation depend on the intensity of the sunlight, with none found in samples kept in the dark for 24 h at 40 °C. It would appear that large amounts of bromate have already been produced in estuarine and coastal waters with unknown effects, as little information is available on the direct toxicity of the bromate ion.

Details of the chlorination experiment referred to previously are now discussed in more detail.

After chlorination, beakers were removed from the sunlight at regular (usually 30-min) intervals, placed in a dark box, and the contents analysed for bromate and residual oxidants without delay. Residual oxidants analyses were performed by the I_3^- spectrophotometric titration procedure described by Carpenter [19] with a pH of 2 and potassium iodide concentration of 4 g/l. Bromate

analyses were made by differential pulse polarography at 25 °C and a pH of 8.35 (after oxygen stripping with nitrogen), using a Princeton Applied Research model 174A polarographic analyser.

A typical polarographic recording is shown in Fig. 2.1; curve (a) is the polarogram obtained for chlorinated seawater analysed immediately after chlorination. Identical traces were observed for non-chlorinated seawater and for chlorinated seawater kept in the dark for periods up to 24 h at temperatures up to 40 °C, which indicates a lack of bromate formation under these conditions ($\text{BrO}_3^- \leq 10^{-7}$ M, less than 0.5% conversion of chlorine). Addition of copper sulfate to give a cupric ion concentration in the seawater of 100 parts per billion did not induce measurable bromate production in the dark. Curve (b) was obtained from a chlorinated (4.9 mg/l) seawater solution that was exposed to full sunlight for 70 min. Curve (c), which is offset by 0.4 μA with respect to curves (a) and (b), shows the presence of 1.0×10^{-5} M sodium bromate in seawater.

Figure 2.2 illustrates kinetic data for the appearance of bromate (Fig. 2.2a) and disappearance of residual oxidants (Fig. 2.2b) in chlorinated seawater ex-

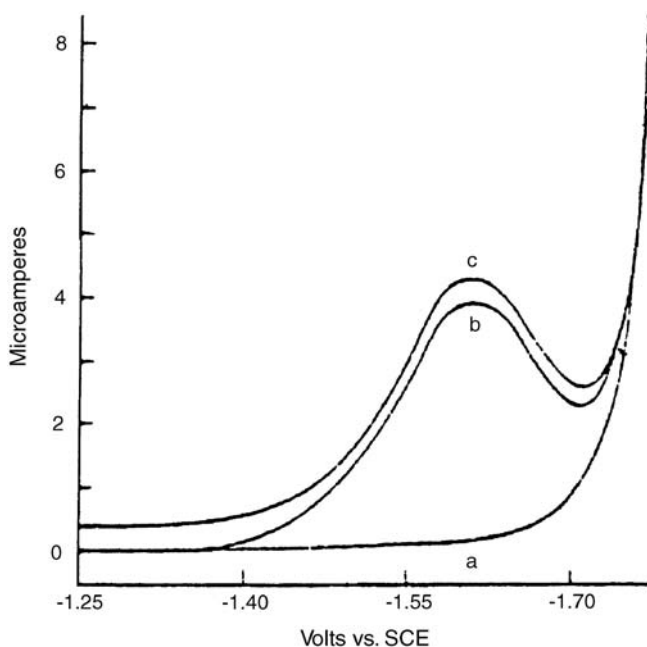

Figure 2.1. Differential pulse polarographic verification of sunlight-induced bromate production in chlorinated seawater. Curve (a) polarogram from untreated seawater, seawater immediately after chlorination to 4.9 ppm, or chlorinated seawater kept in the dark for 4 h at 40 °C. Curve (b) polarogram from chlorinated seawater exposed to full sunlight for 70 min. Curve (c) standard: 1.0×10^{-6} M sodium bromate in seawater, offset with respect to curves (a) and (b). Polarograms were recorded at 25 °C and pH 8.35; SCE: saturated calomel electrode. From [19]

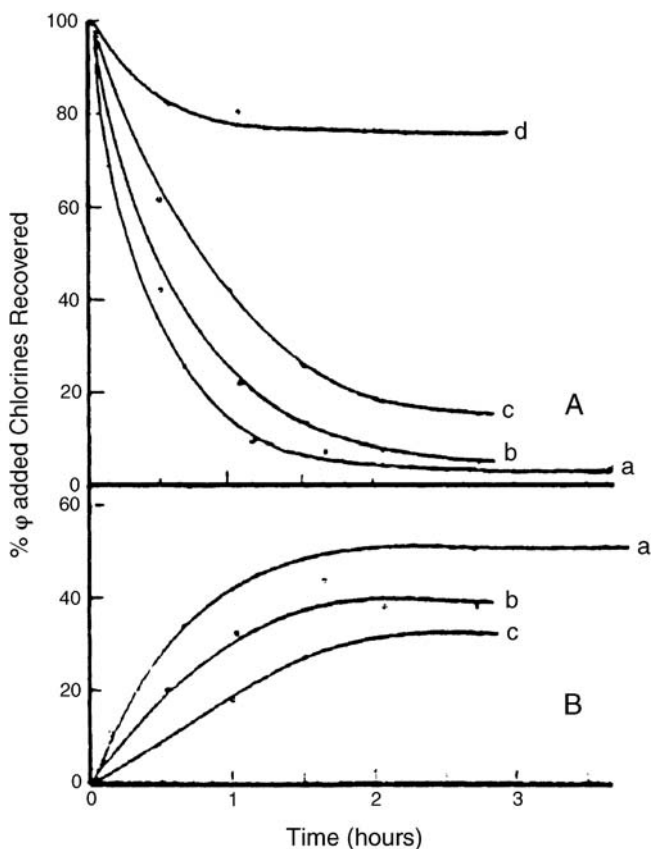

Figure 2.2. (a) Disappearance with time of residual oxidants and (b) concomitant appearance of bromate in chlorinated seawater (4.2–4.9 ppm of chlorine) as a function of exposure to sunlight. The conditions were: Curve (a) full midday sunlight, Curve (b) 65% of full sunlight, and Curve (c) overcast, 20% of full sunlight. Curve (d) shows residual oxidant disappearance in the dark at 40 °C. No bromate production was observed in the dark. From [19]

posed to sunlight. Curves were obtained from solutions exposed to full midday sunlight for the duration of the experiment: curves (b) were for exposure to partial sunlight (the average intensity was approximately 65% of full sunlight); and curves (c) were for overcast conditions (average light intensity, 20% of full sunlight). Curve (d) in Fig. 2.2a shows the disappearance of residual oxidants with time at 40 °C in the dark. The ordinates are calibrated as the percentage of the added chlorine recovered as residual oxidants (Fig. 2.2a) or as bromate formed by decomposition of hypobromite.

The lack of observable bromate production in the dark is not inconsistent with the report of Lewin and Avrahani [20] that substantial bromate was formed in their 0.05 M hypobromide solutions. The solutions used by Macalady

et al. [18], which correspond to current chlorine use in water chlorination processes, were 1000 times more dilute. Using their rate constants, they calculated in their solutions a conversion to bromate of less than 1% after 24 h.

The loss of residual oxidants does not correspond exclusively to bromate formation, and other reactions, including oxidation of organic matter, also take place. The rate and extent of bromate formation depend on the intensity of sunlight.

Solutions of 10^{-5} sodium bromate in seawater were also titrated by using the residual oxidants procedure. The results show that only about 5% of the added bromate appears as residual oxidants. Thus, the apparent residual oxidants remaining after exposure to sunlight could be completely due to bromate.

2.9 Bromide

2.9.1 Titration Method

Bromide in seawater can be determined by the procedure described below, which is capable of determining content down to 0.1 mg/l bromide.

The sample is acidified with sulfuric acid. The bromide content is then determined by the volumetric procedure described by Kolthoff and Yutzky [21]. In this procedure the buffered sample is treated with excess sodium hypochlorite to oxidise bromide to bromate. Excess hypochlorite is then destroyed by addition of sodium formate. Acidification of the test solution with sulfuric acid followed by addition of excess potassium iodide liberates an amount of iodine equivalent to the bromate (i.e., the original bromide) content of the sample. The liberated iodine is titrated with standard sodium thiosulfate.

2.9.2 X-ray Emission Spectrometry

Rose and Cuttita [22] proposed a graphical method for evaluating the background when determining traces of bromide by X-ray emission spectrography (carried out on cellulose pellets containing the residue obtained by evaporation of the sample in the presence of standard bromide solution). Based on this work a graphical method is proposed which provides a value (m_B) of the amount of bromide equivalent to the background, which is substituted into the equation: counts per sec = $k(m + m_s + m_B)$, where k is a factor that depends on the sample, m_B is the bromide content of the original solution, and m_s is the amount of bromide added as "spike". Results obtained by the two methods agree satisfactorily, but it is stressed that both are approximations.

2.9.3

Segmented Flow Analysis

Basel et al. [23] have described methods of compensating for chloride, ammonia, and bicarbonate interferences in determining bromide in saline waters with an automated segmented flow analyser utilising the phenol red method.

2.9.4

Solid State Membrane Electrodes

Walters [24] examined the effect of chloride on the use of bromide and iodide solid state membrane electrodes, and he calculated selectivity constants. Multiple linear regression analysis was used to determine the concentrations of bromide, fluoride, and iodide in geothermal brines, and indicated high interferences at high salt concentrations. The standard curve method was preferred to the multiple standard addition method because of:

1. the deviation from linearity at high salt concentrations of the bromide electrode;
2. the loss of accuracy due to increase in sample volume by using volume increments;
3. the limitations in reading from the Orion meter (0.1 mV);
4. the fact that bromide, fluoride, and iodide were present at relatively low concentrations (where the electrode exhibited nonlinear behaviour).

2.9.5

X-ray Fluorescence Spectroscopy

Sichère et al. [25] determined bromine concentrations in the 0.06–120 mg/l range in brines, directly by X-ray fluorescence using selenium as an internal standard to eliminate interference effects. Lower concentrations of bromine must be concentrated on filter paper containing an ion exchange resin. The same concentrations of chlorine can be determined with the addition of barium to reduce the interferences from carbonates and sulfates. Relative standard deviation was better than 1%. The interference of some other ions (e.g., calcium, potassium, magnesium, sodium, and iron) was examined.

2.9.6

Isotachoelectrophoresis

Fukushi and Hiro [26] have described a capillary-type isotachoelectrophoretic method for the determination of bromide in seawater.

2.10 Chloride

2.10.1 Titration Method

Chlorine at the percentage level at which it occurs in sea water is usually determined by classical procedures using standard silver nitrate as the titrant and potassium chromate indicator, or alternatively by the mercuric thiocyanate procedure using dithizone as indicator. As large dilutions of the original sample are involved in these analyses, it is essential to use grade A glassware and take all other suitable precautions, such as temperature control.

Chloride can also be estimated by potentiometric titration using standard silver nitrate [27]. The results are recorded directly and evaluated by means of a computer program based on the Gran extrapolation method. The determinations have a precision of $\pm 0.02\%$ and since many samples can be titrated simultaneously, the time for a single determination can be reduced to less than 5 min.

Jagner [28] has also described a semi-automatic titration for high-precision determination of chlorine in seawater, where it has been used for the potentiometric determination of total halides (silver electrode) and alkalinity (glass electrode), and for the photometric titration of total alkaline-earth metals. Several titrations can be effected simultaneously.

Grasshoff and Wenck [29] have described a version of the Mohr–Knudsen silver nitrate procedure for the determination of the chlorinity of sea water. In this method, which overcomes the disadvantages of conventional burettes, use is made of a motor-driven piston burette of 20 ml capacity, which is sufficient for a chlorinity range of 0–45 per thousand. The accuracy is the same as for conventional titration. The apparatus is compact and portable.

Several autoanalyser procedures are available for the determination of chlorine.

2.10.2 Ion Selective Electrodes

Noborn [30] has studied the dynamic properties of chloride selective electrodes and their application to sea water. An Orion 94-17 electrode was used in these studies.

In the presence of bromide ions the electrode was subject to a drop in potential, (e.g., 1.5 to 5.7 mV at a $\text{Br}^-:\text{Cl}^-$ ratio of 2000:3) and to delayed response. A considerable hysteresis effect is also observed in concentrated solutions of chloride when the electrode is used in a 1 M chloride solution and then dipped in one that is 0.02 M. Equilibrium is reached only after 10 min. The junction potential is minimised by diluting the test solution with the salt-bridge solution (10% aq. potassium nitrate).

2.10.3

Chronopotentiometry

Chronopotentiometry has also been used to determine chloride ions in seawater [31]. The chloride in the solution containing an inert electrolyte was deposited on a silver electrode (1.1 cm^2) by the passage of an anodic current. The cell comprised a silver disc as working electrode, a symmetrical platinum-disc counter-electrode and a Ag–AgCl reference electrode to monitor the potential of the working electrode. This potential was displayed on one channel of a two-channel recorder, and its derivative was displayed on the other channel. The chronopotentiometric constant was determined over the chloride concentration range 0.5 to 10 mM, and the concentration of the unknown solution was determined by altering the value of the impressed current until the observed transition time was about equal to that used for the standard solution.

2.10.4

Miscellaneous

Wilson [32] has described a portable flow-cell membrane salinometer. Although test solutions are normally passed through the cell, the electrodes can be connected to a remote membrane sensor head by means of salt bridges for measurement of the salinity of estuarine muds in situ. The error is within $\pm 1\%$ over the salinity range 1–40‰.

2.11

Chromate and Dichromate

2.11.1

Atomic Absorption Spectrometry

A method has been developed for differentiating hexavalent from trivalent chromium [33]. The metal is electrodeposited with mercury on pyrolytic graphite-coated tubular furnaces in the temperature range 1000–3000 °C, using a flow-through assembly. Both the hexa- and trivalent forms are deposited as the metal at pH 4.7 and a potential at -1.8 V against the standard calomel electrode, while at pH 4.7, but at -0.3 V , the hexavalent form is selectively reduced to the trivalent form and accumulated by adsorption. This method was applied to the analysis of chromium species in samples of different salinity, in conjunction with atomic absorption spectrophotometry. The limit of detection was $0.05 \mu\text{g/l}$ chromium and relative standard deviation from replicate measurements of $0.4 \mu\text{g}$ chromium (VI) was 13%. Matrix interference was largely overcome in this procedure.

Various workers have discussed the separate determination of Cr(III) and Cr(VI) in seawater [34–38].

Cranston and Murray [35,36] took samples in polyethylene bottles that had been pre-cleaned at 20 °C for four days with 1% distilled hydrochloric acid. Total chromium Cr(VI) + Cr(III) + Cr_p (Cr_p: particulate chromium) was co-precipitated with iron (II) hydroxide, and reduced chromium Cr(III) + Cr_p was co-precipitated with iron (III) hydroxide. These co-precipitation steps were completed within minutes of the sample collection to minimise storage problems. The iron hydroxide precipitates were filtered through 0.4 µm Nucleopore filters and stored in polyethylene vials for later analysis in the laboratory. Particulate chromium was also obtained by filtering unaltered samples through 0.4 µm filters. In the laboratory the iron hydroxide co-precipitates were dissolved in 6 N distilled hydrochloric acid and analysed by flameless atomic absorption. The limit of detection of this method is about 0.1 to 0.2 nM. Precision is about 5%.

2.11.2

Organic Forms of Chromium

In the determination of the two oxidation states of chromium, the calculation of one oxidation state by differencing presupposes that the two oxidation states in question were statistically the only contributors to the total concentration. Because of this, contributions from other possible species such as organic complexes were generally not considered. However, it has been suggested [39] that this presumption may not be warranted and that contributions from organically bound chromium should be considered. This arises from the reported presence in non-saline waters of dissolved organic species that form stable soluble complexes with chromium and may not be readily amenable to determination by procedures commonly in use. The results of research into the valency of chromium present in seawater has not always been consistent. For instance, Grimaud and Michard [40] reported that chromium (III) predominates in the equatorial region of the Pacific Ocean, whereas Cranston and Murray [35] found that practically all chromium is in the hexavalent state in the north-east Pacific. Organic chromium (III) complexes may be formed under the conditions prevailing in seawater as well as inorganic chromium (III) and chromium (VI) forms. Inconsistencies in earlier research may therefore be due at least partly to the fact that the possibility of organic chromium species was ignored [41,42].

Nakayama et al. [38] described a method for the determination of chromium (III), chromium (VI), and organically bound chromium in seawater. They found that seawater in the Sea of Japan contained about 9×10^{-9} M dissolved chromium. This was apportioned approximately as 15% inorganic chromium (III), 25% inorganic chromium (VI), and 60% organically bound chromium.

These workers studied the co-precipitation behaviours of chromium species with hydrated iron (III) and bismuth oxides.

The collection behaviour of chromium species was examined as follows. Seawater (400 ml) spiked with 10^{-8} M chromium (III), chromium (VI), and chromium (III) organic complexes labelled with ^{51}Cr was adjusted to the desired pH by hydrochloric acid or sodium hydroxide.

An appropriate amount of hydrated iron (III) or bismuth oxide was added; the oxide precipitates were prepared separately and washed thoroughly with distilled water before use [43]. After about 24 h, the samples were filtered on $0.4\ \mu\text{m}$ Nuclepore filters. The separated precipitates were dissolved with hydrochloric acid and the solutions obtained were used for γ -activity measurements. In the examination of solvent extraction, chromium was measured by using ^{51}Cr , while iron and bismuth were measured by electrothermal AAS (EAAS). The decomposition of organic complexes and other procedures were also examined by EAAS.

Collection of Chromium (III) and Chromium (VI) with Hydrated Iron (III) or Bismuth Oxide

Only chromium (III) co-precipitates quantitatively with hydrated iron (III) oxide at the pH of seawater, around 8. In order to collect chromium (VI) directly without pre-treatment, e.g., reduction to chromium (III), hydrated bismuth oxide, which forms an insoluble compound with chromium (VI) was used. Chromium (III) is collected with hydrated bismuth oxide (50 mg per 400 ml seawater). Chromium (VI) in seawater is collected at about pH 4 and chromium (VI) is collected below pH 10. Thus both chromium (III) and chromium (VI) are collected quantitatively at the pH of seawater, i.e., around 8.

Collection of Chromium (III) Organic Complexes with Hydrated Iron (III) or Bismuth Oxide

The percentage collection of chromium (III) with hydrated iron (III) oxide may decrease considerably in the neutral pH range when organic materials capable of combining with chromium (III), such as citric acid and certain amino acids, are added to the seawater [41]. Moreover, synthesised organic chromium (III) complexes are scarcely collected with hydrated iron (III) oxide over a wide pH range [41].

As it was not known what kind of organic matter acts as the major ligand for chromium in seawater, Nakayama et al. [38] used ethylene diaminetetraacetic acid (EDTA) and 8-quinolinol-4-sulfuric acid to examine the collection and decomposition of organic chromium species, because these ligands form quite stable water-soluble complexes with chromium (III), although they are not actually present in seawater. Both of these chromium (III) chelates are stable in seawater at pH 8.1 and are hardly collected with either of the hydrated oxides. The organic chromium species were then decomposed to inorganic

chromium (III) and chromium (VI) species by boiling with 1 g ammonium persulfate per 400 mL seawater acidified to 0.1 M with hydrochloric acid. Iron and bismuth, which would interfere in AAS, were 99.9% removed by extraction from 2 M hydrochloric acid solution of 5% tri-iso-octylamine. Chromium (III) remained almost quantitatively in the aqueous phase in the concentration range 10^{-9} – 10^{-6} M, whether or not iron or bismuth was present. However, as about 95% of chromium (VI) was extracted by the same method, samples which may contain chromium (VI) should be treated with ascorbic acid before extraction so as to reduce chromium (VI) to chromium (III).

When the residue obtained by the evaporation of the aqueous phase after extraction was dissolved in 0.1 M nitric acid and the resulting solution was analysed by EAAS, a negative interference seemingly due to residual organic matter was observed. This interference was successfully removed by digesting the residue on a hot plate with 1 ml concentrated hydrochloric acid and 3 ml of concentrated nitric acid. This process had the advantage that the interference of chloride in the AAS was eliminated during the heating with nitric acid.

Results reported by various workers for chromium concentrations in seawater are listed in Table 2.1. In most of these methods, co-precipitation with

Table 2.1. Data from the literature on the chromium contents of seawater (from author's own files)

Reference	Date	Locations	Methods	Concentration ($\mu\text{g/l}$)
Ishibashi and Shigematsu [44]	1950	Japanese coastal	Al(OH) ₃ co ppt	Cr(III) 0.01
Chuecas and Riley [45]	1966	British Coastal	Fe(OH) ₃ co ppt acidic reduction	Cr(III) 0.46 Cr(VI) 0.01
Fukai [48, 49]	1967	Mediterranean	Fe(OH) ₃ co ppt acidic reduction	Cr(III) 0.02–0.25 Cr(VI) 0.05–0.38
Kuwamoto and Murai [46]	1970	Pacific Ocean	BiOH(NO ₃) ₂ co ppt acidic reduction	Cr(III)? Cr(III) Cr(VI) 0.13–0.90 Cr(VI)? OrgCr 0.07–0.27
Grimaud and Michard [40]	1974	Pacific Ocean	Fe(OH) ₃ co ppt Fe(OH) ₃ reduction	Cr(III) 0.24–0.52 Cr(VI) 0.03–0.11
Yamamoto et al. [49]	1974	Pacific Ocean	Al(OH) ₃ co ppt acidic reduction	Total 0.06–0.96 Cr(III) 17–99%
Cranston and Murray [35]	1978	Pacific Ocean	Fe(OH) ₃ co ppt Fe(OH) ₃ reduction	Cr(III) 0.005 Cr(VI) 0.15
Nakayama et al. [38]	1981	Pacific Ocean and Japan Sea		Cr(III) 0.06 Cr(VI) 0.14 OrgCr 0.26 Total 0.46

hydrated iron (III) oxide was used to separate chromium (III) from chromium (VI) and the chromium (VI) concentration was subsequently determined by suitable reduction of chromium (VI) to chromium (III) before a further co-precipitation. In others, hydrated iron (II) oxide served as both reductant and carrier. Isibashi and Shigematsu [44] used co-precipitation with aluminium hydroxide and did not employ reduction, so that the value reported most likely corresponds to inorganic chromium (III) alone; in fact, the value for inorganic chromium (III) obtained by Nakayama et al. [38] is in remarkable agreement.

In Chuecas and Riley's study [45] the samples were stored for a long time under acidic conditions before analysis, so that chromium (VI) could have been reduced to chromium (III) and any organic chromium dissociated, with the result that all chromium species would have been determined as chromium (III). When a sample is reduced under acidic conditions, organic chromium is likely to partly dissociate, initially increasing the apparent concentration of chromium (VI). When the analytical procedure described earlier [40, 46] was re-examined, the value for chromium (III) was found actually to be the sum of chromium (III) and chromium (VI), while the value for chromium (VI) was partly organic chromium. For the same reason the chromium (VI) values determined by Fukai [47], Fukai and Vas [48], and Yamamoto et al. [49] probably include organic chromium species. When iron (II) precipitate is used, there seems to be little chance of determining the organic chromium species as chromium (VI). The value for chromium (VI) reported by Cranston and Murray [35] agrees quite well with the value for chromium (VI) reported by them, although the value for chromium (III) is lower. The results obtained by Grimaud and Michard [40] for chromium (III) differ considerably, but the discrepancies cannot be discussed because details of the analytical procedure were not given. It seems reasonable to conclude that the inconsistency of past results concerning the dominant chromium species and the total chromium concentration in seawater can be attributed, at least partly, to the fact that the presence of organic chromium species was not considered properly.

Mullins [37] has described a procedure for determining the concentrations of dissolved chromium species in seawater. Chromium (III) and chromium (VI) separated by co-precipitation with hydrated iron (III) oxide and total chromium are determined separately by conversion to chromium (VI), extraction with ammonium pyrrolidine diethyl dithiocarbamate into methyl isobutyl ketone, and determination by AAS. The detection limit is 40 ng/l chromium. The dissolved chromium not amenable to separation and direct extraction is calculated by difference. In waters investigated, total concentrations were relatively high (1–5 µg/l), with chromium (VI) the predominant species in all areas sampled with one exception, where organically bound chromium was the major species.

Ahern et al. [50] have discussed the separation of chromium in seawater. The method involved co-precipitation of trivalent and hexavalent chromium, separately, from samples of surface seawater, and determination of the chromi-

um in the precipitates and particulate matter by thin-film X-ray fluorescence spectrometry. An ultraviolet irradiation procedure was used to release bound metal. The ratios of labile trivalent chromium to total chromium were in the range 0.4–0.6, and the totals of labile tri- and hexavalent chromium were in the range 0.3–0.5 $\mu\text{g/l}$. Bound chromium ranged from 0 to 3 $\mu\text{g/l}$, and represented 0–90% of total dissolved chromium. Acidification of the samples in the usual manner for the determination of trace metals altered the proportion of trivalent to hexavalent chromium.

2.12 Fluoride

2.12.1 Spectrophotometric Method

Fletsch and Richards [51] determined fluoride in seawater spectrophotometrically as the cerium alizarin complex. The cerium alizarin complex and chelate was formed in 20% aqueous acetone at pH 4.35 (sodium acetate buffer) and, after 20–60 min, the extinction measured at 625 nm (2.5 cm cell) against water. The calibration graph was rectilinear for 8–200 $\mu\text{g/l}$ fluoride; the mean standard deviation was $\pm 10 \mu\text{g/l}$ at a concentration of 1100 $\mu\text{g/l}$ fluoride.

Spectrophotometric procedures based on the lanthanum alizarin complex have also been described [52].

2.12.2 Ion Selective Electrodes

Ion selective electrodes are emerging as a method of preference for the determination of fluoride in seawater [53–58].

Anfalt and Jagner [57] measured total fluoride ion concentration by means of a single-crystal fluoride selective electrode (Orion, model 94-09). Samples of seawater were adjusted to pH 6.6 with hydrochloric acid and were titrated with 0.01 M sodium fluoride with use of the semi-automatic titrator described by Jagner [28]. Equations for the graphical or computer treatment of the results are given. Calibration of the electrode for single-point potentiometric measurements at different seawater salinities is discussed.

Rix et al. [58] have commented that earlier published potentiometric methods for determining fluoride in seawater appear to be unnecessarily complicated in several respects. Reagents, such as a total ionic strength adjustment buffer (TISAB), are added to the sample at high concentrations to adjust the pH and ionic strength and to liberate the majority of fluoride bound in metal complexes. The possibility of introducing solution contamination when using high concentrations of TISAB is always a potential hazard and, if this step can be avoided, this will obviously be advantageous. Furthermore, a significant drawback with most earlier methods was the difficulty of establishing

an acceptable or representative matrix in which to prepare standards, as the actual matrix is often unknown in non-saline waters. This aspect of fluoride determination in seawater has received considerable attention, and extensive and elaborate procedures have been used to match the sample and standard matrices [53].

The method of standard additions is frequently employed in environmental analysis for samples of variable matrix [59]. The method of data treatment used by Rix et al. [58] is similar to that originally described by Gran [2] for the exact determination of potentiometric end-points. Brand and Rechnitz [60], Baumann [61], and Craggs et al. [62] have described procedures employing the method of standard additions to selective ion electrode potentiometry, but no data are available for non-saline waters using this direct method except for the work of Liberti and Mascini [63], who determined fluoride in mineral waters. The procedure used by Rix et al. [58] is exceedingly simple, and the method of data treatment provides a linear plot, the slope and intercept of which give independent measures of the original concentration of fluoride in the sample. Total fluoride concentration is determined despite the fact that the activity of the fluoride ion is the parameter monitored by the fluoride ion selective electrode.

The concentration of fluoride in seawater is approximately 1.4 ppm or 7×10^{-5} mol/l and the fluoride electrode has been shown to give a Nernstian response at this level – and indeed three orders of magnitude lower than this level [64].

It has been well established that the fluoride electrode is highly selective in its response to the activity of fluoride, with the only common interferant being hydroxide [65]. Nevertheless, although seawater has a uniform pH of 8, possible hydroxide interference was shown not to be a problem.

Complexation of fluoride by metal ions in seawater has previously been overcome by the addition of TISAB solution. The reagent is presumed to release the bound fluoride by preferential complexation of the metal ions with EDTA type ligands present in the TISAB. Examination of the metal ions present in seawater [66, 67] suggests that magnesium is the major species forming fluoride complexes. Theoretical calculations demonstrate that even this species is unlikely to interfere.

Results for seawater of 35.21% salinity are presented in Table 2.2. The average value of 1.35 ± 0.05 mg/l is in excellent agreement with previously published data [53, 54, 68, 69].

The first result in Table 2.2 is the value found directly. The next set of three results shows that recovery of fluoride after deliberate addition to the spiked samples is excellent. The fifth result is that obtained from an acidified sample. The sixth, seventh, eighth, and ninth sets of data show that the expected fluoride concentration is still obtained after deliberate addition of aluminium or iron in the form of their alums. Aluminium (III) and iron (III) form very strong fluoride complexes [70] and, provided that sufficient time is allowed for equilibration (as noted by Baumann [64] for very low fluoride concentrations), total flu-

Table 2.2. Determination of fluoride in seawater under a variety of conditions to demonstrate the reliability of the method [58]

Sample	[F] found (mg/l)	Conditions	
Point Lonsdale, Victoria, Australia	1	1.40 ± 0.05	pH = 8
		$1.35 \pm 0.05^*$	
	2	1.30 ± 0.05	1.56 ppm spike added. $[F]_T$ determined = 2.80 ± 0.05 ppm
	3	1.40 ± 0.05	4.0 ppm spike added $[F]_T$ determined = 5.40 ± 0.05 ppm
	4	1.30 ± 0.05	8.6 ppm spike added $[F]_T$ determined = 9.90 ± 0.05 ppm
	5	1.28 ± 0.05	pH 5.50 (HCl added)
	6	1.36 ± 0.05	5 mg potassium alum added/100 cm ³ seawater ≈ 2.7 ppm Al ₃ ⁺
	7	1.43 ± 0.10	50 mg potassium alum added/100 cm ³ seawater ≈ 27 ppm Al ₃ ⁺ . Equilibration time of electrode very long.
	8	1.39 ± 0.05	50 mg potassium alum and 3 g ammonium citrate added/100 cm ³ seawater.
		$1.37 \pm 0.05^*$	
	9	1.30 ± 0.05	37 mg ferric alum added to 100 cm ³ seawater and pH adjusted to 3 by adding a few drops of glacial acetic acid solution ≈ 40 ppm Fe ³⁺ .
	10	1.37 ± 0.05	50 cm ³ TISAB added/100 cm ³ seawater
	11	1.28 ± 0.10	Calculated via addition of TISAB and calibration versus synthetic seawater.
Synthetic		0.0068 ± 0.0008	pH = 5.8
		0.0053 ± 0.0008	pH = 4.3

* This determination was performed approximately three weeks after the first.

oride could still be determined accurately by the method of standard additions, even though the artificial concentration levels of aluminium and iron were three orders of magnitude greater than those normally occurring in seawater [66]. This observation is noteworthy, since the work of Liberti and Mascini [63] suggests that the direct method cannot be used for fluoride in the presence of high relative concentrations of aluminium (III) or iron (III) aquo species.

This complication is probably avoided in seawater (even with relatively high concentrations of aluminium (III) and iron (III)) by the large excess of chloride ions, which partially complex with any aluminium (III) or iron (III) present to produce chlorocomplexes of the metals, thus sequestering their influence on the fluoride concentration. Data obtained after adding TISAB to release bound fluoride and using the calibration method further confirm the validity of the direct method. The data in Table 2.2 demonstrate the absence of hydroxide ion interference caused by metal ion complexation, and indicate that total rather than free fluoride is determined by the method of standard additions. The slope of the linear portion of the graph was 58.8 mV per decade change

in fluoride ion concentration, and this value was used in the calculations of fluoride concentration in seawater. At lower levels of fluoride ($< 10^{-6}$ mol/l), it might be assumed that the electrode behaves in a non-Nernstian fashion. However, calculations of the kind suggested by Rix et al. [58] reveal that the deviation from linearity can satisfactorily be attributed to residual fluoride resulting either from reagent contamination or from the electrode itself, at a concentration of about 3×10^{-7} mol/l.

The level of fluoride in seawater is at least two orders of magnitude higher than this residual level, hence contamination does not significantly influence the results.

Ke and Regier [71] have described a direct potentiometric determination of fluoride in seawater after extraction with 8-hydroxyquinoline. This procedure was applied to samples of seawater, fluoridated tap-water, well-water, and effluent from a phosphate reduction plant. Interfering metals, e.g., calcium, magnesium, iron, and aluminium were removed by extraction into a solution of 8-hydroxyquinoline in 2-butoxyethanol-chloroform after addition of glycine-sodium hydroxide buffer solution (pH 10.5 to 10.8). A buffer solution (sodium nitrate-1,2-diamino-cyclohexane-*N,N,N',N'*-tetra-acetic acid-acetic acid; pH 5.5) was then added to adjust the total ionic strength and the fluoride ions were determined by means of a solid membrane fluoride-selective electrode (Orion, model 94-09). Results were in close agreement with and more reproducible than those obtained after distillation [72]. Omission of the extraction led to lower results. Four determinations can be made in one hour.

2.12.3

Photoactivation Analysis

Photoactivation analysis has also been used to determine fluoride in seawater [73]. In this method a sample and simulated seawater standards containing known amounts of fluoride are freeze-dried, and then irradiated simultaneously and identically, for 20 min, with high-energy photons. The half-life of ^{18}F (110 min) allows sufficient time for radiochemical separation from the seawater matrix before counting. The specific activities of sample and standards being the same, the amount of fluoride in the unknown may be calculated. The limit of detection is 7 ng fluoride, and the precision is sufficient to permit detection of variations in the fluoride content of oceans. The method can be adapted for the simultaneous determination of fluorine, bromine, and iodine.

2.12.4

Atomic Absorption Spectrometry

Fluoride has been determined in seawater in amounts down to 8 ng/ml by a method based on the formation of AlF in an electrothermal graphite furnace, followed by molecular absorption at 227.45 nm [74].

2.13 Formate

There is considerable interest in the role of formic acid and other volatile fatty acids in the early diagnosis of organic matter in lacustrine and marine sediments. Formic acid is an important fermentation product or substrate for many aerobic and anaerobic bacteria and for some yeasts. In the atmosphere, formic acid is an important product in the photochemical oxidation of organic matter.

Despite its potential importance, formic acid has proven difficult to quantify at submicromolar levels in non-saline water samples. Formidable analytical difficulties are associated with its detection in highly saline samples. Ion exclusion, anion exchange, and reversed-phase high performance liquid chromatography techniques based on the direct detection of formic acid in aqueous samples are prone to interferences (especially from inorganic salts) that ultimately limit the sensitivity of these methods.

A potentially more sensitive and selective approach involves reaction of formic acid with a reagent to form a chromophore or fluorophore, followed by chromatographic analysis. A wide variety of alkylating and silylating reagents have been used for this purpose. Two serious drawbacks to this approach are that inorganic salts and/or water interfere with the derivatisation reaction, and these reactions are generally not specific for formic acid or other carboxylic acids. These techniques are prone to errors from adsorption losses, contamination, and decomposition of the components of interest. Enzymic techniques, in contrast, are ideal for the analysis of non-saline water samples, since they are compatible with aqueous media and involve little or no chemical or physical alterations of the sample (e.g., pH, temperature).

2.13.1 High Performance Liquid Chromatography (HPLC)

As a consequence of the previous considerations Kieber et al. [75] have developed an enzymic method to quantify formic acid in non-saline water samples at sub-micromolar concentrations. The method is based on the oxidation of formate by formate dehydrogenase with corresponding reduction of β -nicotinamide adenine dinucleotide (β -NAD⁺) to reduced β -NAD⁺ (β -NADH); β -NADH is quantified by reversed-phase high performance liquid chromatography with fluorimetric detection. An important feature of this method is that the enzymic reaction occurs directly in aqueous media, even seawater, and does not require sample pre-treatment other than simple filtration. The reaction proceeds at room temperature at a slightly alkaline pH (7.5–8.5), and is specific for formate with a detection limit of 0.5 μ M ($S/N = 4$) for a 200 μ l injection. The precision of the method was 4.6% relative standard deviation ($n = 6$) for a 0.6 μ M standard addition of formate to Sargasso seawater. Average re-

coveries of 2 μM additions of formate to seawater were 103%. Inter-calibration with a Dionex ion chromatographic system showed an excellent agreement of 98%. Concentrations of formate present in natural samples ranged from 0.2 to 0.8 μM for Biscayne Bay seawater.

2.14

Hypochlorite

2.14.1

Spectrophotometric Method

Williams and Robertson [76] have described a simple inexpensive method for determining reactive chlorine in non-saline waters. It involves addition of bromine, which is oxidised by the reactive chlorine in the sample, and which in turn brominates fluorescein to give a pink derivative; this can be measured visually or spectrophotometrically, or the decrease in fluorescein can be measured fluorimetrically. Potential applications of the method are indicated.

The basis of this method is that when normal seawater is chlorinated at the usual levels of 1 to 10 mg/l of chloride, the bromine in seawater ($8.1 \times 10^{-4} \text{ M}$, 65 mg/l at salinity = 35‰) is rapidly and quantitatively oxidised to BrO^- and HBrO . If 50 mg/l of bromide is added to distilled or fresh waters containing HClO plus ClO^- , then HBrO plus BrO^- are both formed. The HBrO plus BrO^- will in turn rapidly brominate fluorescein (9-[*o*-carboxyphenyl]-6-hydroxy-3-isoxanthone) to give the pink tetrabromo derivative eosin yellow (2,4,5,7-tetrabromo-9-[*o*-carboxyphenyl]-6-hydroxy-3-isoxanthone), provided the molar ratio of bromide to fluorescein is 4:1. The resultant increase in eosin can be measured visually or spectrophotometrically, and the decrease in fluorescein measured fluorometrically. If the molar ratio of bromide to fluorescein is < 4:1, then the mono-, di-, and tri-bromo derivatives are formed reproducibly. These derivatives have extinction coefficients close to eosin and are accounted for in the standardisation.

2.15

Iodate

2.15.1

Spectrophotometric Method

Truesdale [77] has described autoanalyser procedures for the determination of iodate and total iodine in seawater. The total iodine content of seawater (approximately 50–60 $\mu\text{g/l}$) is believed to be composed of iodate (30–60 $\mu\text{g/l}$ of I) and iodine-iodine (0–20 $\mu\text{g/l}$) with perhaps a few $\mu\text{g/l}$ of organically

bound iodine. In both of the methods, the iodine species of interest are first converted to iodate. Then the iodate is reacted with acid and excess iodide to give iodonium ions, I_3^+ , which are detected spectrophotometrically at 350 nm. In the total iodine procedure, a pre-oxidation step is therefore required; here bromine water was chosen. Interference from nitrite ions, which in acid also oxidise iodide to iodonium ions, is suppressed by sulfamic acid, which destroys the nitrite ions.

Originally the objective of this work was only the automatic iodate–iodine procedure. This was needed to give the extra precision called for in an earlier study [78], which suggested that most of the observed variation in iodate–iodine results for the deeper waters (> 200 m) of the oceans is due to analytical imprecision. However, in addition to the original objective the procedure for total-iodine has developed. This development stemmed from the need to test the likelihood of iodonium ions, produced in the iodate procedure, being reduced by substances occurring naturally in seawater. This problem was defined when Truesdale [79] showed that molecular iodine is reduced rapidly in some seawaters. He found that the oxidising capacity of 260 $\mu\text{g/l}$ of iodine–iodine added to a filtered coastal seawater disappeared within 30 min. The effect of such a process on the iodate method would be to lower the observed iodate concentrations. Further, the effect, if it occurred, would be expected to have its maximum effect in coastal and oceanic surface waters where primary productivity is highest; these waters also appear to contain the lowest recorded iodate concentrations. To test for the iodonium-ion reduction, a pre-oxidation step including iodine–iodine was incorporated in the analytical method for iodate–iodine. Having accomplished the iodine water pre-oxidation step successfully, it was logical to attempt the bromine water pre-oxidation and thereby produce the total-iodine method.

Methods for the following three determinations were described by Truesdale [77]:

(1) Determination of iodate without pre-oxidation

Iodate in the buffered sample is reacted with sulfamic acid (to destroy nitrite) and potassium iodide to produce the iodonium ion I_3^+ , which is determined spectrophotometrically at 350 nm.

(2) Determination of iodate with pre-oxidation

Iodine water is added to an acetic acid sodium acetate buffered sample to reoxidise to iodate any iodine-containing substances produced by reduction of iodate by naturally occurring reducing substances present in the sample. Total iodate (i.e., iodate present in the original sample as iodate plus additional iodate produced by iodine water treatment) is then reacted with phenol solution at

pH 5.4 to destroy excess free iodine, and then with sulfamic acid and potassium iodide to produce the iodonium ion, which is estimated spectrophotometrically at 350 nm.

This determination will test for the presence of naturally occurring reducing agents in seawater which by their action on iodonium ions could lead to an underestimate in iodate concentration. (The use of the method on anoxic waters containing sulfide is a prime example of when this precaution should be taken.)

(3) Determination of total iodine with pre-oxidation

This procedure is the same as that described in (2) except that the iodine water is replaced by bromine water, and the buffer contains added sodium bromide, [i.e. sodium bromide–acetic acid–sodium acetate instead of the acetic acid–sodium acetate buffer used in method (2)].

In all three methods a blank is obtained. To ascertain the blank, excess sodium thiosulfate is added to the potassium iodide reagent at a concentration of 4.0×10^{-14} mol/l. Samples were re-analysed and the appropriate blank subtracted from the sample signal.

Variations in the salinity of the sample have very little effect on the accuracy of the results obtained in all three methods provided that the difference in salinity between the samples and the standards does not exceed 2.5%.

Determinations of iodate without pre-oxidation in Pacific seawater by the previous method gave a mean result of 583 $\mu\text{g/l}$ with a standard deviation of 0.23 $\mu\text{g/l}$. For samples containing between 40 and 60 $\mu\text{g/l}$, standard deviations of 0.19 $\mu\text{g/l}$ (iodate method with pre-oxidation), 0.12 $\mu\text{g/l}$ (iodate method without pre-oxidation), and 0.43 $\mu\text{g/l}$ (total iodine method) were obtained.

A set of Pacific open-ocean samples were analysed for iodate–iodine using both the procedure which incorporates pre-oxidation with iodine water and that which does not. Also, in a similar exercise total iodine was determined using both the method that incorporates pre-oxidation with bromine water and the catalytic method using the reaction between Ce(IV) and As(III) [81]. Variance tests showed that differences between either replicates or methods was not significant.

Truesdale and Smith [80] also carried out a comparative study of the determination of iodate in open ocean, inshore Irish seawaters and waters from the Menai Straits, using the spectrophotometric method (with and without pre-oxidation using iodine water) and also by a polarographic method [82].

Figure 2.3 shows the results obtained in a comparison of these methods on a range of deep-sea and offshore samples. The line of gradient 1.0 on each diagram shows the result which would have occurred had agreement been obtained. The Student t-test showed that in both exercises the colorimetric method with iodine water treatment yielded higher values than that without

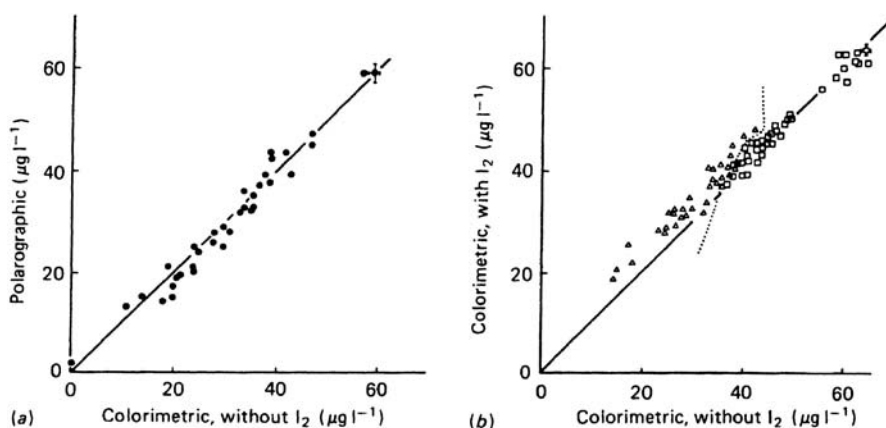

Figure 2.3. The distribution of sample concentrations encountered in the comparisons of the colorimetric method without iodine with (a) the polarographic method and (b) the colorimetric method with iodine water. For convenience the *line* of the unit gradient is shown in both cases. In each case the precision (95% confidence level) for each measurement is shown for the most concentrated sample. In (b) the *broken line* divides on shore (Δ) and offshore (\square) samples. From [80]

iodine water treatment, and the polarographic method yielded, on average, a concentration lower than that obtained by the colorimetric procedure without iodine water.

Schnepfe [83] has described yet another procedure for the determination of iodate and total iodine in seawater. To determine total iodine 1 ml of 1% aqueous sulfamic acid is added to 10 ml seawater which, if necessary, is filtered and then adjusted to a pH of less than 2.0. After 15 min, 1 ml sodium hydroxide (0.1 M) and 0.5 ml potassium permanganate (0.1 M) are added and the mixture heated on a steam bath for one hour. The cooled solution is filtered and the residue washed. The filtrate and washings are diluted to 16 ml and 1 ml of a phosphate solution (0.25 M) added (containing $0.3 \mu\text{g}$ iodine as iodate per ml) at 0°C . Then 0.7 ml ferrous chloride (0.1 M) in 0.2% *v/v* sulfuric acid, 5 ml aqueous sulfuric acid (10%) – phosphoric acid (1:1) are added at 0°C followed by 2 ml starch–cadmium iodide reagent. The solution is diluted to 25 ml and after 10–15 min the extinction of the starch–iodine complex is measured in a -5 cm cell. To determine iodate the same procedure is followed as is described previously except that the oxidation stage with sodium hydroxide – potassium permanganate is omitted and only 0.2 ml ferrous chloride solution is added. A potassium iodate standard was used in both methods.

The total iodine procedure is claimed to be relatively free from interference by foreign ions. The iodate procedure is subject to interference by bromate and sulfite ions. This method is claimed to be capable of determining down to $0.1 \mu\text{g}$ iodine in the presence of 500 mg chloride ion and 5 mg of bromide ion.

2.16 Iodide

Iodine species in seawater exist as iodide (I^-) and iodate (IO_3^-). Iodide, which is thermodynamically unstable in oxygenated water, is usually a minor species in seawater compared to iodate, and total inorganic iodine concentration is approximately in the range 50–60 $\mu\text{g/l}$ [84–95]. However, iodide concentration ranges from 30 $\mu\text{g/l}$ near the shore and in ocean surface and bottom waters to below 1 $\mu\text{g/l}$ (deep ocean water). Iodine is an essential micronutrient for many organisms. Iodide in seawater is produced by biologically mediated reduction of iodate [96] and is also produced under reduction conditions. Thus, the distribution of iodide and iodate gives clues for understanding the marine environment [87, 88, 93, 95]. Iodide has been determined mainly by difference between total inorganic iodine (I^- and IO_3^-) and IO_3^- iodate has been determined by differential pulse polarography [88, 89, 91, 94–97] and the spectrophotometric method after conversion of iodate to I_3^- in acidic solution [83, 92]. Total inorganic iodine was determined after converting iodide to iodate by using chemical or photochemical means [82, 84, 85, 87, 91, 93, 94]. However, as the detection limit of iodide by the difference technique is not very good (for example, 1.3–2.5 $\mu\text{g/l}$ for differential pulse polarography [88]), it is desirable to detect iodide directly.

To date, a few methods have been proposed for direct determination of trace iodide in seawater. The first involved the use of neutron activation analysis (NAA) [86], where iodide in seawater was concentrated by strongly basic anion-exchange column, eluted by sodium nitrate, and precipitated as palladium iodide. The second involved the use of automated electrochemical procedures [90]; iodide was electrochemically oxidised to iodine and was concentrated on a carbon wool electrode. After removal of interference ions, the iodine was eluted with ascorbic acid and was determined by a polished Ag_3SI electrode. The third method involved the use of cathodic stripping square wave voltammetry [92] (See Sect. 2.16.3). Iodine reacts with mercury in a one-electron process, and the sensitivity is increased remarkably by the addition of Triton X. The three methods have detection limits of 0.7 (250 ml seawater), 0.1 (50 ml), and 0.02 $\mu\text{g/l}$ (10 ml), respectively, and could be applied to almost all the samples. However, NAA is not generally employed. The second electrochemical method uses an automated system but is a special apparatus just for determination of iodide. The first and third methods are time-consuming.

2.16.1 Titration Method

Iodide in seawater can be determined by the procedure described below, which is capable of determining down to 0.1 mg/l iodide [97]. In this method the

sample is strongly acidified with hydrochloric acid titrated with 0.00125 M potassium iodate solution, which converts iodide via iodine monochloride:



The end-point, which occurs with the complete conversion of iodide to iodine monochloride, is indicated by the disappearance of the violet iodine colour from a chloroform layer present in the titration flask.

2.16.2

Spectrophotometric Method

Sugawara [98] has described a spectrophotometric method for the determination of iodide in seawater. Various workers [99, 100] have modified this procedure.

Matthews and Riley [99] preconcentrated iodide by co-precipitation with chloride ions. This is achieved by adding 0.23 g silver nitrate per 500 ml of seawater sample. Treatment of the precipitate with aqueous bromine and ultrasonic agitation promote recovery of iodide as iodate which is caused to react with excess iodide under acid conditions, yielding I_3^- . This is determined either spectrophotometrically or by photometric titration with sodium thiosulfate. Photometric titration gave a recovery of $99.0 \pm 0.4\%$ and a coefficient of variation of $\pm 0.4\%$ compared with $98.5 \pm 0.6\%$ and $\pm 0.8\%$, respectively, for the spectrophotometric procedure.

Shizuo [100] allowed the silver halide precipitate obtained in the co-precipitation process to stand in contact with the solution for more than 20 h to ensure quantitative collection of iodide on the precipitate. He then evaporated the oxidised iodate solution to 5–10 ml and again allowed the solution to stand for more than 12 h before the colorimetric determination. There was no interference from bromine compounds. The errors were then within $\pm 3\%$.

2.16.3

Cathodic Stripping Voltammetry

Luther et al. [92] have described a procedure for the direct determination of iodide in seawater. By use of a cathodic stripping square-wave voltammetry, it is possible to determine low and sub-nanomolar levels of iodide in seawater, freshwater, and brackish water. Precision is typically $\pm 5\%$ (1σ). The minimum detection limit is 0.1–0.2 nM (12 parts per trillion) at 180 sec deposition time. Data obtained on Atlantic Ocean samples show similar trends to previously reported iodine speciation data. This method is more sensitive than previous methods by 1–2 orders of magnitude. Triton X-100 added to the sample enhances the mercury electrode's sensitivity to iodine.

2.16.4

Ion Chromatography

This is a simple method for determining trace iodide in seawater. Two factors are essential to attain good sensitivity:

1. Separation of iodide from an excess of anions in seawater.
2. Highly sensitive detection of iodide.

Iodide was determined by an iodide-selective electrode ($\text{Ag}_2\text{S}/\text{AgI}$) after other anions were separated by a rhodium nitrate element [101]. However, the electrode that was stabilised by $0.5\ \mu\text{m}$ iodide responded to chloride ions in seawater, and the detection limit of iodide was $22\ \mu\text{g}/\text{l}$.

Ito and Sumahara [102] showed that $0.1\ \text{M}$ sodium chloride eluent was effective for the separation of iodide in seawater, due to faster elution of an excess of anions in seawater and slow elution of iodide with hydrophobicity on conventional low capacity anion exchange columns. In a more recent work Ito [103] has described a simple and highly sensitive ion chromatographic method with ultraviolet detection for determining iodide in seawater. A high-capacity anion-exchange resin with polystyrene–divinylbenzene matrix was used for both preconcentration and separation of iodide. Iodide in artificial seawater (salinity: 35‰) was trapped quantitatively ($98.8 \pm 0.6\%$) without peak broadening on a preconcentrator column, and was separated with $0.35\ \text{M}$ sodium perchlorate and $0.01\ \text{M}$ phosphate buffer (pH 6.1). On the other hand, the major anions in seawater, chloride and sulfate ions, were partially trapped (5–20%) and did not interfere in the determination of iodide. The detection limit for iodide was $0.2\ \mu\text{g}/\text{l}$ for 6 ml of artificial seawater. This method when applied to determination of iodide had a detection limit of $18.3\ \mu\text{g}/\text{l}$.

2.16.5

Miscellaneous

Buchberger et al. [104] carried out a selective determination of iodide in brine. The performance of a potentiometric method using an ion-selective electrode and of liquid chromatography coupled with ultraviolet detection at 230 nm were compared as methods for the determination of iodide in the presence of other iodide species. Satisfactory results were obtained from the potentiometric method provided the solution was first diluted tenfold with $5\ \text{M}$ sodium nitrate, and external standards were used. Better reproducibility was, however, achieved with HPLC, provided precautions were taken to prevent reduction of iodine to iodide in the mobile phase, for which extraction of iodine with carbon tetrachloride prior to analysis was recommended. This was the pre-

ferred method for automated analyses of iodine brines (iodide concentrations of 30–40 mg/l).

Krishnamoorthy and Iyer [105] have reported a method for determining nanogram levels of iodide in saline water samples containing a large excess of interfering chloride ions. The anions are first bound to a strong base anion exchanger, from which the chloride ion is readily eluted. The iodide is then eluted with 2 M ammonium nitrate and the iodide is determined based on its catalytic effect on the reduction of cerium (IV) by arsenic (III). The method is claimed to have an accuracy comparable to that obtained by NAA.

Varma [106] determined iodide in seawater in amounts down to 2 mg/l by a method based on pre-column derivatisation of the iodide into 4-iodo-2,6-dimethyl phenol. An ultraviolet detector was employed.

2.17 Molybdate

2.17.1 Atomic Absorption Spectrometry

A limited amount of work has been carried out on the determination of molybdenum in seawater by AAS [107–109] and graphite furnace atomic absorption spectrometry [110]. In a recommended procedure a 50 ml sample at pH 2.5 is preconcentrated on a column of 0.5 g *p*-aminobenzylcellulose, then the column is left in contact with 1 mol/l ammonium carbonate for 3 h, after which three 5 ml fractions are collected. Finally, molybdenum is determined by AAS at 312.2 nm with use of the hot-graphite-rod technique. At the 10 mg/l level the standard deviation was 0.13 µg.

2.18 Nitrate

2.18.1 Spectrophotometric Methods

Spencer and Brewer [111] have reviewed methods for the determination of nitrate in seawater. Classical methods for determining low concentrations of nitrate in seawater use reduction to nitrite with cadmium/copper [112,116,117] or zinc powder [113] followed by conversion to an azo dye using *N*-1-naphthylethylenediamine dihydrochloride and spectrophotometric evaluation. Malhotra and Zaroni [114] and Lambert and Du Bois [115] have discussed the interference by chloride in reduction-azo dye methods for the determination of nitrate.

2.18.2

Ultraviolet Spectroscopy

Ultraviolet spectrometry has also been used to determine nitrates. In a method for determining high levels of nitrate described by Mertens and Massart [118] the sample, diluted to contain 0.5–1 mg/l nitrate is acidified, filtered through a 0.5 μm filter, and the extinction measured against a blank at 210–220 nm. The concentration of nitrate is obtained from a calibration graph. Interference from chloride, bromide, organic matter, carbonate, bicarbonate, and nitrite is largely removed by using as blank a solution prepared by boiling 10 ml of the sample with 0.5 g Raney nickel for 30 min and then stirring for 90 min at 90 °C, to reduce nitrate to ammonia. The extinction coefficient is 8500 at 210 nm and 4100 at 220 nm. Beer's law is valid up to 10 mg/l at 210 nm and up to 15 mg/l at 220 nm. The standard deviations for a sample containing 17.4 mg/l of nitrate were 0.3 and 0.5 mg/l at 210 and 220 nm, respectively. No systematic errors were detected.

Previous ultraviolet methods for determining nitrate have attempted to allow for humic acid interference [119–122]. However, with the exception of Morris [122] these methods of allowance are inaccurate at humic acid concentrations above about 3.5 mg/l. Unfortunately, none of these methods have attempted to make any allowance for ultraviolet-absorbing pollutant organic compounds or interfering inorganic ions. Thus their application to water analyses other than for relatively unpolluted fresh waters is open to question.

Brown and Bellinger [123] have proposed an ultraviolet technique that is applicable to both polluted and unpolluted fresh and some estuarine waters. Humic acid and other organics are removed on an ion exchange resin. Bromide interference in seawater samples can be minimised by suitable dilution of the sample but this raises the lower limit of detection such that only on relatively rich (0.5 mg/l NO_3N) estuarine and inshore waters could the method be used. Chloride at concentrations in excess of 10 000 mg/l do not interfere.

The method is either not affected by or can allow for interference from phosphate, sulfate, carbonate, bicarbonate, nitrate, coloured metal complexes, ammonia dyes, detergents, phenols, and other ultraviolet-absorbing substances. The method incorporates three features designed to reduce interferences:

1. Humic acid interference is reduced by carrying out measurements at 225 nm, a longer wavelength than that used by previous workers (210–220 nm).
2. Removal of inorganic interferences, particularly the removal of bromide interference in seawater by fivefold dilution of the sample, the removal of nitrate by addition of sulfamic acid, and the removal of metals by passage through Amberlite IR 120 cation exchange resin.
3. Removal of ultraviolet absorbing organics by passage through a specific ion exchange resin such as Amberlite XAD-2.

Table 2.3 compares nitrate determinations in the presence of various interfering substances for this method and for two alternate methods – phenoldisulfonic acid and ion selective electrode methods. In general, the method proposed by Brown and Bellinger [123] is less subject to interference.

The speed of the nitrate ion selective electrode makes its use potentially ideal for nitrate determinations on a large number of samples. However, the results from adding various interfering substances (Table 2.3) seem to cast some doubt upon the values obtained in the presence of chloride and bicarbonate, for although the results are precise, they are not accurate, being approximately 20–30% high.

Table 2.3. The effects of various interferences on the determination of nitrates by three methods. For all determinations the concentration of NO_3N was 1.125 mg/l. All concentrations are given in mg/l [123]

Interference	Method					
	Phenoldisulfonic acid		UV method		Selective ion electrode	
	Uncorrected	Corrected	Uncorrected	Corrected	Uncorrected	Corrected
Chloride:						
100	0.62	1.07*	1.08		1.08	1.55 [§]
1000			1.05			
Bicarbonate–Carbonate:						
100	1.13		1.06		0.87	1.24 [¥]
200	1.23					
1000			1.13			
Bicarbonate–Chloride:						
100 Cl:200						1.58 [¶]
HCO ₃						
100 Cl:100						1.46 [¶]
HCO ₃						
50 Cl:100						1.46 [¶]
HCO ₃						
Nitrate:						
0.304	1.11		1.48	1.10 [†]		
1.500						1.31 [¶]
3.040	1.13			1.06 [†]		
Ammonium:						
1.4	0.98					
14.0	0.66		1.08			1.13 [¶]
1400.0			1.08			

* Addition of exact amount of silver sulfate to precipitate chloride with no excess silver.

† Addition of sulfamic acid (final concentration in sample approximately 20 mg/l).

§ Addition of saturated silver sulfate (1–10 ml sample). Not recalibrated. ¥ Addition of 2 M acetic acid to sample (0.09 ml per 30 ml sample). Not recalibrated. ¶ Calibrate for presence of 3 ml saturated silver sulphate and 0.09 ml of 2 M acetic acid in 30 ml sample.

2.18.3

Chemiluminescence Method

Chemiluminescent techniques have been used to determine nanomolar quantities of nitrate and nitrite in seawater [124, 125]. This method depends on the selective reduction of these species to nitric oxide, which is then determined by its chemiluminescent reaction with ozone, using a commercial nitrogen oxides analyser. The necessary equipment is compact and sufficiently sturdy to allow shipboard use. A precision of ± 2 nmol/l is claimed, and an analytical range of 2 nmol/l with analysis rates of 10–12 samples hourly.

In this method [124] nitrate, nitrate plus nitrite or nitrite alone are selectively reduced to nitric oxide, which is swept from the sample in a helium carrier gas flow. Nitric oxide is allowed to react with ozone in a nitrogen oxide analyser, where it forms nitrogen dioxide. The return of the nitrogen dioxide to the ground state is accompanied by release of a photon, which is detected by a photomultiplier. The integrated output of the photomultiplier over the time that the nitric oxide is purged from the sample is proportional to the nitrite content of the sample.

Linear calibration plots are obtained by this procedure covering the range up to 1 nmol/l for nitrate and for nitrite.

2.18.4

Flow Injection Analysis

Flow injection analysis is another technique that has been applied to the determination of nitrate and nitrite in seawater. Anderson [126] used flow injection analysis to automate the determination of nitrate and nitrite in seawater. The detection limit of his method was $0.1 \mu\text{mol/l}$. However, the sampling rate was only 30 per hour which is low for flow injection analysis. Reactions seldom go to completion in a determination by flow injection analysis [127, 128] because of the short residence time of the sample in the reaction manifold. Anderson selected a relatively long residence time so that the extent of formation of the azo dye was adequate to give a detection limit of $0.1 \mu\text{mol/l}$. This reduced the sampling rate because only one sample is present at a time in the post-injector column in flow injection analysis. Any increase in reaction time causes a corresponding increase in the time needed to analyse one sample.

Johnson and Petty [129] reduced nitrate to nitrite with copperised cadmium, which was then determined as an azo dye. The method is automated by means of flow injection analysis technique. More than 75 determinations can be made per hour. The detection limit is $0.1 \mu\text{mol/l}$, and precision is better than 1% at concentrations greater than $10 \mu\text{mol/l}$.

2.18.5

Continuous Flow Analysis

Hyde and Hill [130] used the copper–cadmium reduction method to determine nitrate in seawater. The construction of a copper–cadmium (50–50 *w/w*) reactor column for use during continuous flow analysis at sea is described. A 100% yield could be obtained using a 20 cm × 3 cm column fitted with grains of copper–cadmium alloy between 500 and 350 μm in size. The column maintained its reactivity during three months storage prior to an oceanographic cruise, and during the four week cruise period. Its performance was similar to that of the Stainton-type cadmium wire column, but it had the advantages of easier preparation and easier control of reductor volume.

2.18.6

Cathodic Stripping Voltammetry

Van den Berg [131] used this technique to determine nanomolar levels of nitrate in seawater. Samples of seawater from the Menai Straits were filtered and nitrite present reacted with sulfanilamide and naphthyl-amine at pH 2.5. The pH was then adjusted to 8.4 with borate buffer, the solution de-aerated, and then subjected to absorptive cathodic stripping voltammetry. The concentration of dye was linearly related to the height of the reduction peak in the range 0.3–200 nM nitrate. The optimal concentrations of sulfanilamide and naphthyl-amine were 2 mM and 0.1 mM, respectively, at pH 2.5. The standard deviation of a determination of 4 nM nitrite was 2%. The detection was 0.3 nM for an adsorption time of 60 sec. The sensitivity of the method in seawater was the same as in fresh water.

2.18.7

Ion Chromatography

Tyree and Bynum [132] described an ion chromatographic method for the determination of nitrate and phosphate in seawater. The pre-treatment comprised vigorous mixing of the sample with a silver-based cation-exchange resin, followed by filtration to remove the precipitated silver salt.

Dahiloef et al. [133] have described an ion chromatographic method for the determination of nitrate and phosphate in seawater. A small sample volume (20 μl) is needed, and detection limits of 0.5 and 1.0 μM were obtained for nitrate and phosphate, respectively.

2.18.8

Bacteriological Method

Sigman et al. [134] have pointed out that nitrate is the predominant form of bioavailable (or “fixed”) nitrogen in the ocean, and the natural isotopic

variations of this species provide an important tool for studying the nitrogen cycle. Depending on the environment, the $^{15}\text{N}/^{14}\text{N}$ ratio of seawater nitrate can provide information on virtually all of the major transformations of nitrogen that occur in the ocean, including dinitrogen fixation, uptake of fixed nitrogen by phytoplankton, nitrification, and denitrification. The $^{18}\text{O}/^{16}\text{O}$ ratio of nitrate has been studied in freshwater and terrestrial systems, and has been shown to provide an additional important constraint on natural processes. Generally, both nitrogen and oxygen isotopic compositions of nitrate have many potential applications in oceanography, hydrology, and atmospheric chemistry, but natural-abundance isotopic studies of nitrate have been restricted by analytical limitations, especially in marine systems.

Methods to measure the nitrogen isotopic composition of nitrate in natural waters typically involve the reduction of nitrate to ammonia using diffusion or distillation, reaction to nitrogen gas, and isotopic analysis of the nitrogen [135]. Methods also exist for the coupled nitrogen and oxygen isotopic analysis of nitrate in freshwater that are based on the purification of the nitrate salt, and the direct, high-temperature conversion of nitrate to N_2 and CO_2 [136–138]. However, weaknesses in the available methods have made some nitrate isotope investigations difficult and have precluded others. The published N_2 -based methods for nitrogen isotopic analysis normally require micromoles of nitrate-N, which is prohibitive when only millilitres of water are available. The methods available for the nitrogen isotopic analysis of seawater nitrate require nitrate concentrations of 2–3 μM or higher [135], largely because of the limited efficiency with which ammonia is extracted by distillation and diffusion. In addition, these methods have both a significant reagent blank and a blank associated with dissolved organic nitrogen that varies with sample type, which can be large [139]. Finally, these methods are typically labour- or time-intensive. With respect to oxygen isotopic analysis, the weaknesses in the available methods are even more restrictive. In particular, there is no published method for the oxygen isotopic analysis of nitrate in seawater.

Sigman et al. [134] have described a bacterial method for measuring the isotopic composition of seawater nitrate at the natural-abundance level. The method is based on the analysis of nitrous oxide gas (N_2O) produced quantitatively from nitrate by denitrifying bacteria. The classical denitrification pathway consists of the stepwise reduction of nitrate (NO_3^-) to nitrite (NO_2^-), nitric oxide (NO), nitrous oxide (N_2O), and dinitrogen (N_2):



Each of these steps is carried out by a dedicated enzyme encoded by a distinct gene. There is a rich literature on natural and genetically modified bacterial strains that lack discrete components of the denitrification pathway [140]. The

method described takes advantage of naturally occurring denitrifiers that lack an active N_2O reductase, the enzyme that reduces N_2O to N_2 [140].

The precision of the method is better than 0.2‰ (1 SD) at concentrations of nitrate down to $1 \mu M$, and the nitrogen isotopic differences among various standards and samples are accurately reproduced. For samples with $1 \mu M$ nitrate or more, the blank of the method is less than 10% of the signal size, and various approaches may reduce it further.

2.18.9

Miscellaneous

Cerda et al. [142] have described a sequential injection sandwich technique for the simultaneous determination of nitrate and nitrite in seawater.

2.19

Nitrite

2.19.1

Spectrophotometric Methods

Spencer and Brewer [144] have reviewed methods for the determination of nitrite in seawater. Workers at WRC, UK [145] have described an automated procedure for the determination of oxidised nitrogen and nitrite in estuarine waters. The procedure determines nitrite by reaction with *N*-1 naphthylethylene diamine hydrochloride under acidic conditions to form an azo dye which is measured spectrophotometrically. The reliability and precision of the procedure were tested and found to be satisfactory for routine analyses, provided that standards are prepared using water of an appropriate salinity. Samples taken at the mouth of an estuary require standards prepared in synthetic seawater, while samples taken at the tidal limit of the estuary require standards prepared using deionised water. At sampling points between these two extremes there will be an error of up to 10% unless the salinity of the standards is adjusted accordingly. In a modification of the method, nitrate is reduced to nitrite in a micro cadmium/copper reduction column and total nitrite estimated. The nitrate content is then obtained by difference.

Matsunaga et al. [146] have also described a similar procedure for the determination of nitrite in seawater. To 500 ml of sample is added 10 ml of sulfanilamide (1% solution) in 2 M hydrochloric acid and 5 ml aqueous *N*-1-naphthylethylene-diamine hydrochloride (0.1%). After 10 min, 5 ml of aqueous dodecylbenzenesulfonate (0.5%) is added and the mixture extracted for 2 min with 50 ml of carbon tetrachloride. Then 75 ml of acetone and 10 ml of 0.1 M hydrochloric acid are added to the separated organic layer and the azo dye

back-extracted into the acid. The extinction of the acid layer is measured at 543 nm in a 2 cm cell. The sensitivity for 0.001 extinction in 1 cm cells is 0.7 ng atom nitrite-N per litre.

Gianguzza and Orecchio [147] have carried out comparative trials of various methods for estimating nitrites in seawaters. These workers compared a method using sulfanilic acid/ α -naphthylamine complexes with a method using sulfanilamide/*N*(1-naphthyl) ethylenediamine complexes for the determination of nitrites in saline waters. The second method has the greater sensitivity and lower detection limits. The former method is subject to interference from chlorides, and this interference can be completely eliminated by the coupling diazotisation procedure of the latter method.

Anion exchange resins have been used to determine extremely low concentrations of nitrite down to nanomoles in seawater. Wada and Hattori [148] formed an azo dye from the nitrite using *N*-1 naphthylethylene diamine dihydrochloride and then adsorbed the dye in an anion exchange resin. The dye is then eluted from the column with 60% acetic acid and measured spectrophotometrically at 550 nm.

2.19.2

Flow Injection Analysis

Fogg et al. [149] used flow injection voltammetry to reduce nitrite at a glassy carbon electrode in acidic bromide or chloride medium and applied the method to seawater.

2.19.3

Isotope Dilution Gas Chromatography

Mass spectrometry has been applied to the determination of nitrite and nitrate in seawater. This method produced results that were free from interference by other forms of nitrogen [150].

2.19.4

Cathodic Stripping Voltammetry

Absorptive cathodic stripping voltammetry has been used [151, 152] to determine nanomolar levels of nitrite in seawater. The nitrite is derivatised by diazotisation with sulfanilamide and coupled with 1-naphthylamine to form an azo dye. The dye adsorbs onto a mercury drop electrode and its reduction is fully reversible. The concentration of dye is linearly related to concentration of nitrite in the range 0.3–200 nM. Down to 0.3 nM nitrite can be determined in seawater for an adsorption time of 60 seconds.

2.20 Nitrate and Nitrite

2.20.1

Spectrophotometric Method

Bajic and Jaselskis [153] described a spectrophotometric method for the determination of nitrate and nitrite in seawater. It included the reduction of nitrate and nitrite to hydroxylamine by the zinc amalgam reactor (Jones reductor) at pH 3.4 and reoxidation of the product with iron (III) in the presence of ferrozine. Interference by high levels of nitrite could be eliminated with azide treatment. Levels of nitrate of 0.1 mg/l could be detected with a precision of 3% in the presence of large amounts of nitrite and chloride.

Nagashima et al. [154] used second derivative spectrometry to determine nitrate and nitrite in seawater. Samples of artificial seawater, pure water and chlorinated water were pumped through a column containing cadmium/copper powder which converted nitrate to nitrite. The produced and existing nitrite was reduced to nitrogen monoxide, and the mixture was fed through a gas-liquid separator. Evolved nitrogen monoxide was purged by nitrogen into a heated optical cell where the second derivative absorbance was recorded at 214 nm. Various experimental conditions were investigated. A reducing agent of 0.13 M sodium iodide/13 M phosphoric acid, a mixing coil 5 m long operated at 50 °C and a separator 50 cm long with the outer tube heated to 90 °C were selected. Nitrite was determined directly, and nitrate indirectly, by measuring differences in nitrite with and without the converter.

The Department of the Environment UK [155] has described a number of alternative methods for the determination of total oxidised nitrogen (nitrate and nitrite) in aqueous solution, while specific methods for nitrate and nitrite are also included. Among the methods for total oxidised nitrogen, one is based on the use of Devarda's alloy for reduction of nitrate to ammonia, and another uses copperised cadmium wire for reducing nitrate to nitrite, which is determined spectrophotometrically. Nitrate may also be determined spectrophotometrically after complex formation with sulfosalicylic acid; or following reduction to ammonia, the ammonia is eliminated by distillation and determined titrimetrically. Other methods include direct nitrate determination by ultraviolet spectrophotometry, measurements being made at 210 nm, and the use of a nitrate-selective electrode. Details of the scope, limits of detection, and preferred applications of the methods are given in each case.

Various other workers have discussed spectrophotometric methods for the determination of nitrate and nitrite [156–163].

2.20.2

Flow Injection Analysis

Flow injection analysis has been adapted to automatic air-segmented continuous flow systems, e.g., the Technicon AutoAnalyzer system. Several reducing

agents such as zinc [164], cadmium [161], and amalgamated [163, 165] or coppered cadmium [147, 148] have been investigated. Reductor columns are, however, difficult to operate in an air-segmented stream. This problem can be avoided by using the continuous flow injection technique developed by Ruzicka and Hansen [128, 166].

The flow injection technique is based on three main principles: sample injection, reproducible timing, and controlled dispersion [128]. The dispersion can be described as limited, medium, or large; in a colorimetric system based on a reaction between the sample and a suitable reagent, a medium dispersion is preferred. Thus in the flow injection determination of nitrate, the reductor column should not excessively increase the dispersion. In a coppered cadmium reductor, more than 90% of the total nitrate is reduced within 1–2 s with minimum risk of further reduction of nitrite [167]. Consequently, the reductor can be made very small, which results in a minimal increase of dispersion.

In this development of a flow injection method for the determination of nitrate and nitrite, Anderson [168] chose the Shinn [155] method to reduce nitrate and nitrite because of its high sensitivity and relative freedom from interferences. Anderson [168] used flow injection in the photometric determination of nitrite and nitrate with sulfanilamide and *N*-(1-naphthyl) ethylenediamine as reagents, as discussed next. The detection limit is 0.05 μM for nitrite and 0.1 μM for nitrate at a total sample volume of 200 μL . Up to 30 samples can be analysed per hour with relative precision of about 1%.

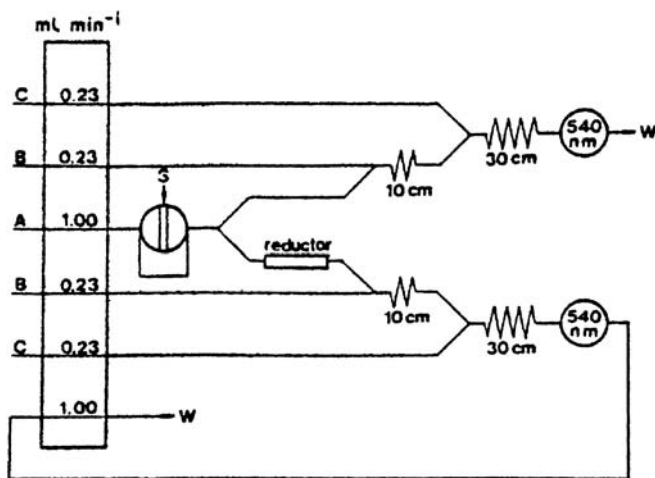

Figure 2.4. Flow diagram for the colorimetric determination of nitrite and nitrate. The internal diameter of the Tygon tubing was 0.64 mm for the 0.23 ml/min flow rates and 1.30 mm for the 1.00 ml/min flow rates; all other tubing was 0.7 mm id. The reagents were (A) carrier stream, (B) sulfanilamide solution, and (C) *N*-(1-naphthyl) ethylene diamine solution. S denotes the point of injection and W waste. From [168]

A schematic diagram of the flow injection system used by Anderson [126] is shown in Fig. 2.4. An Ismatec model MP 13 peristaltic pump was used. Different flow rates were obtained by changing the pump tube diameter, as indicated in the legend to Fig. 2.4. The injection port was a rotary valve [131, 170]. The sample volume could be varied between 10 and 1000 μl simply by changing the length of the sample loop.

In the analysis of seawater, the only significant interference arises from turbidity caused by particles in the sample. Prior filtration of the sample is therefore necessary. For anoxic waters, however, sulfide concentrations over 2 μM were found to decrease the absorbance. This was overcome by adding an excess of either Cd^{2+} or Hg^{2+} to the sample [171, 172].

A submersible flow injection-based sensor has been used to determine nitrite and nitrate in seawater. Detection limits of 0.1 μM for nitrate and a linear range of 0.1–0.55 μM were achieved [173].

2.20.3

Continuous Flow Analysis

Workers at the Department of the Environment UK [174] have described continuous flow methods for the determination of total oxidised nitrogen and nitrite in seawater. Limits of detection are 1.3 $\mu\text{g/l}$ (total oxidised nitrogen) and 0.26 $\mu\text{g/l}$ (nitrite). Within-batch standard deviations for total oxidised nitrogen range from 0.28 $\mu\text{g/l}$ to 17.5 $\mu\text{g/l}$ at the total oxidised nitrogen level, to 0.96 $\mu\text{g/l}$ at the 560 $\mu\text{g/l}$ total oxidised nitrogen level. Within-batch standard deviations for nitrite range from 0.056 $\mu\text{g/l}$ at the 3.5 $\mu\text{g/l}$ nitrite level to 0.042 $\mu\text{g/l}$ at the 70 $\mu\text{g/l}$ nitrite level.

Reduction of nitrate is achieved by the use of a mixing coil containing copperised cadmium wire. Spectrophotometric evaluation of the nitrite produced is achieved by the use of sulfanilamide *N*(1 naphthyl) ethylene diamine hydrochloride system.

2.20.4

Reverse Phase Ion Interaction Liquid Chromatography

Ito et al. [175] used this technique employing octadecyl silane reverse phase columns coated with cetyltrimethyl ammonium chloride for the determination of nitrite and nitrate in seawater.

2.20.5

Miscellaneous

Sakamoto et al. [143] described an automated, near real-time analysis with microprocessor-controlled syringe pump modules for the determination of

nitrate in seawater. This provides an automated nitrate mapping system for use on open ocean and coastal waters.

Sample preservation by pasteurisation has been applied to the preservation of nitrite and nitrate in seawater [152]. Samples can be stored for several months before analysis.

2.21

Perrhenate

Matthews and Riley [176] have described the following procedure for determining down to $0.06 \mu\text{g/l}$ perrhenate in sea water. From 6 to $8 \mu\text{g/l}$ rhenium was found in Atlantic sea water. The rhenium in a 15 litre sample of sea water acidified with hydrochloric acid is concentrated by adsorption on a column of De-Acidite FF anion-exchange resin (Cl form), followed by elution with 4 mol/l nitric acid and evaporation of the eluate. The residue (0.2 ml), together with standard and blanks, are irradiated in a thermal neutron flux of at least 3×10^{12} neutrons cm^{-2} for at least 50 h. After a decay period of two days, the sample solution and blank are treated with potassium perrhenate as carrier and evaporated to dryness with a slight excess of sodium hydroxide. Each residue is dissolved in 5 mol/l sodium hydroxide. Hydroxylammonium chloride is added (to reduce Tc(VIII) which arises as ^{99m}Tc from activation of molybdenum present in the samples), and the Re(VII) is extracted selectively with ethyl methyl ketone. The extracts are evaporated, the residue is dissolved in formic acid:hydrochloric acid (19:1), the rhenium is adsorbed on a column of Dowex-1, and the column is washed with the same acid mixture followed by water and 0.5 mol/l hydrochloric acid. The rhenium is eluted at 0°C with acetone:hydrochloric acid (19:1), and is finally isolated by precipitation as tetraphenylarsonium perrhenate. The precipitate is weighed to determine the chemical yield, and the 186-rhenium activity is counted with an end-window Geiger-Müller tube. The irradiated standards are dissolved in water together with potassium perrhenate. At a level of $0.057 \mu\text{g/l}$ rhenium, the coefficient of variation was $\pm 7\%$.

2.22

Phosphate

2.22.1

Reverse Flow Injection Analysis

This technique differs from flow injection analysis in the sense that whereas in the latter technique the sample plug is injected into a flowing stream of reagent, in the former technique plugs of reagent are injected into a continuous stream of the sample. Under these conditions the amount of sample in the zone of the reagent will increase as the dispersion increases. The sample will become well

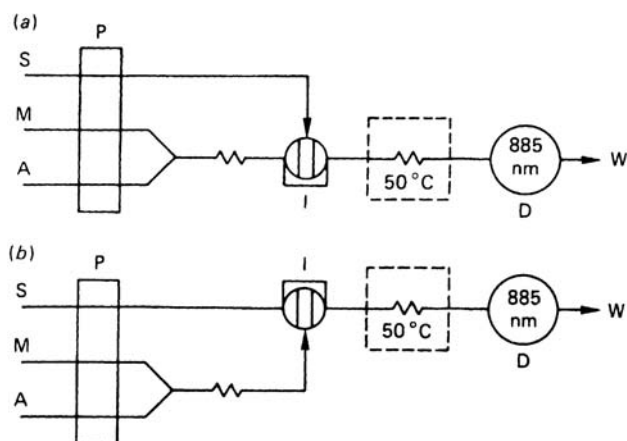

Figure 2.5. Analytical manifolds for the determination of phosphate by flow injection analysis (a) and reverse flow injection (b). The symbols S, M, and A are the seawater, mixed reagent, and the ascorbic acid solutions. The pump injection valve and detector are represented by P, I, and D, respectively. W = waste. From [177]

mixed with the reagent as its concentration increases, so that well-formed peaks will result. Thus, an analysis can be successfully performed by this technique with a sample concentration in the zone of the reagent that is typically in the range from 67% to 90% of the sample concentration in the carrier stream.

Johnson and Petty [177] adapted reverse flow injection analysis to the well-known Murphy and Riley [178] colorimetric phosphomolybdate reduction method for the determination of phosphate.

Figure 2.5a and b show flow sheets for the determination of phosphate by flow injection analysis and reversed flow injection analysis, respectively.

The effects of residence time on the peak height of a $2.5 \mu\text{mol/l}$ phosphate standard are shown in Fig. 2.6. The residence time was defined as the time from injection of the reagents to the appearance of the maximum signal at the detector. Residence times were varied by changing the flow rate (1.0–3.5 ml/min in 0.5 ml/min increments) and the length of the reaction tube (0.5, 1.0, and 1.5 m). The peak height increased rapidly with residence time in both 0.5 and 0.8 mm id tubes, and then levelled off after 15 sec. The change is about the same when the residence time is increased by using longer tubes. This suggests the increase peak height is due mainly to an increase in the extent of reaction.

2.22.2

Spectrophotometric Method

Spencer and Brewer [111] have reviewed methods for the determination of phosphate in seawater. Earlier methods for the determination of phosphate in seawater are subject to interferences, particularly by nitrate. In one early

Figure 2.6. Effect of residence time on peak height. The *squares* (0.5 mm id tubing) and *circles* (0.8 mm id) were obtained by changing the flow rate through a 1 m reaction tube. The *square* at the extreme right corresponds to 0.7 mm/min. The *triangles* were obtained by using a 0.8 mm id tube and a flow rate of 2.0 ml/min. Residence time was varied by changing the tube length. From [177]

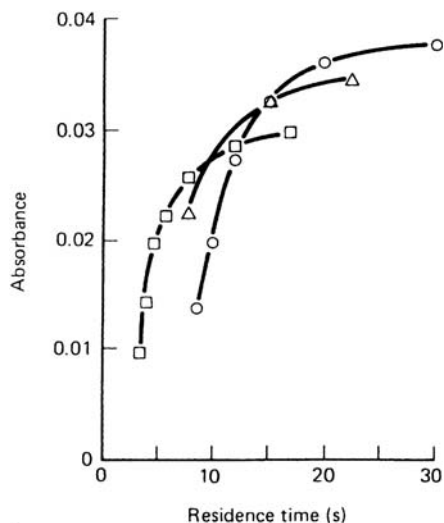

method [179], the filtered seawater sample is acidified with nitric acid and perchloric acid in the presence of hydroxylammonium chloride and ammonium chloride, and the phosphomolybdate complex extracted with methylisobutyl ketone. This extract is then reduced with acidic stannous chloride and ascorbic acid, and the extinction measured at 725 nm. Hosokawa and Ohshima [180] heated the sample (50 ml) for 20 min on a boiling water bath with 2 ml Mo(VI)–Mo(V) reagent (hydrochloric acid added (10 ml) to Mo(VI) (2 M; 10 ml), then zinc (0.3 g) added, and after the zinc has dissolved, hydrochloric acid was added to 100 ml). The mixture was cooled and the extinction measured at 830 nm. The resulting blue complex remains stable for at least two months and has an ϵ value of 26 000. Nitrate interferes if present in concentrations greater than 1 $\mu\text{g/l}$, and should first be reduced to nitrate with zinc in acidic medium. AsO_4^{3-} interferes at levels of 10 mg/l. The salt error was about 5% at a chloride concentration of 1.9%.

Isaeva [181] described a phosphomolybdate method for the determination of phosphate in turbid seawater. Molybdenum titration methods are subject to extensive interferences and are not considered to be reliable when compared with more recently developed methods based on solvent extraction [182–187], such as solvent-extraction spectrophotometric determination of phosphate using molybdate and malachite green [188]. In this method the ion pair formed between malachite green and phosphomolybdate is extracted from the seawater sample with an organic solvent. This extraction achieves a useful 20-fold increase in the concentration of the phosphate in the extract. The detection limit is about 0.1 $\mu\text{g/l}$, standard deviation 0.05 ng^{-1} (4.3 $\mu\text{g/l}$ in tap water), and relative standard deviation 1.1%. Most cations and anions found in non-saline waters do not interfere, but arsenic (V) causes large positive errors.

In earlier work, Motomizu et al. [187] used ethyl violet as counter-ion for phosphomolybdate. The spectrophotometric determination of phosphate by solvent extraction of molybdophosphate with ethyl violet is more sensitive than previously reported [179–190], and less troublesome; a single extraction is adequate. However, in the determination of phosphorus at ng/l levels in waters it has certain disadvantages. First, the absorbance of the reagent blank becomes too large for the concentration effect achieved by the solvent extraction to be of much use. For example, when 20 ml of sample solution and 5 ml of organic solvent were used, the absorbance of the reagent blank was 0.14. Secondly, the shaking time needed was long and the colour of the extract faded gradually if the shaking lasted more than 30 min.

However, malachite green [188] gave a stable dark yellow species in 1.5 M sulfuric acid (probably a protonated one), whereas ethyl violet became colourless within 30 min even in only 0.5 M sulfuric acid.

In the malachite green procedure, 10 ml of the sample solution containing up to 0.7 µg phosphorus as orthophosphate was transferred into a 25 ml test tube. To this solution was added 1 ml each of 4.5 M sulfuric acid and the reagent solution. The solution was shaken with 5 ml of a 1:3 v/v mixture of toluene and 4-methylpentan-2-one for 5 min. After phase separation, the absorbance of the organic phase was measured at 630 nm against a reagent blank in 1 cm cells.

The absorption spectra of the ion pair shows a maximum at 632 nm. Linear calibration graphs are obtained even when the aqueous phase volume is increased to 100 ml (and 7 ml of extracting solvent are used). When 50 ml of sample are used, 0.1 µg/l of phosphorus can be detected.

Arsenic (V) causes large positive errors – arsenic (V) at a concentration of 10 µg/l produces an absorbance of 0.07, but can be masked with tartaric acid (added in the reagent solution). When arsenic (V) was present at concentrations of 50 µg/l it was masked with 0.1 ml of 1×10^{-4} M sodium thiosulfate added after the sulfuric acid.

For a 25 ml sample, almost all of the foreign ions tested, when present at the concentrations listed in Table 2.4, produced an absorbance of less than 0.005. The recovery of phosphorus was good: 99–103%. The relative standard deviation for phosphorus was 0.6% for 21.0 µg/l in seawater.

A commonly used procedure for the determination of phosphate in seawater and estuarine waters uses the formation of the molybdenum blue complex at 35–40 °C in an autoanalyser and spectrophotometric evaluation of the resulting colour. Unfortunately, when applied to seawater samples, depending on the chloride content of the sample, peak distortion or even negative peaks occur which make it impossible to obtain reliable phosphate values (Fig. 2.7). This effect can be overcome by the replacement of the distilled water-wash solution used in such methods by a solution of sodium chloride of an appropriate concentration related to the chloride concentration of the sample. The chloride content of the wash solution need not be exactly equal to that of the sample. For chloride contents in the sample up to 18 000 mg/l (i.e., seawater),

Table 2.4. Effect of other ions [188]

Ion	Added as	Concentration mol/l	Absorbance*
None			0.549
Na ⁺ , Cl ⁻	NaCl	0.3	0.545
K ⁺	KCl	1 × 10 ⁻²	0.548
SO ₄ ²⁻	Na ₂ SO ₄	1 × 10 ⁻²	0.552
Ca ²⁺	CaCl ₂	1 × 10 ⁻²	0.551
Mg ²⁺	MgCl ₂	1 × 10 ⁻²	0.548
HCO ₃ ⁻	NaHCO ₃	1 × 10 ⁻²	0.556
Al ₃ ⁺	KAl(SO ₄) ₂	1 × 10 ⁻³	0.550
Fe ₃ ⁺	FeNH ₄ (SO ₄) ₂	1 × 10 ⁻³	0.551
NH ₄ ⁺	NH ₄ Cl	1 × 10 ⁻³	0.557
NO ₃ ⁻	NaNO ₃	1 × 10 ⁻³	0.548
Cr ³⁺	CrCl ₃	1 × 10 ⁻³	0.549
Mn ²⁺	MnCl ₂	1 × 10 ⁻³	0.549
Co ²⁺	CoCl ₂	1 × 10 ⁻³	0.549
Cd ²⁺	CdCl ₂	1 × 10 ⁻³	0.552
Ni ²⁺	NiCl ₂	1 × 10 ⁻³	0.549
Cu ²⁺	CuCl ₂	1 × 10 ⁻³	0.553
Zn ²⁺	ZnCl ₂	1 × 10 ⁻³	0.546
Br ⁻	NaBr	1 × 10 ⁻³	0.546
B(III)	Na ₂ B ₄ O ₇	1 × 10 ⁻³	0.552
SiO ₃ ²⁻	Na ₂ SiO ₃	5 × 10 ⁻⁴	0.553
VO ₃	NH ₄ VO ₃	1 × 10 ⁻⁵	0.556
WO ₄ ²⁻	(NH ₄) ₁₀ W ₁₂ O ₄₁	1 × 10 ⁻⁵	0.554
I ⁻	NaI	1 × 10 ⁻⁵	0.550
Laurylsulfate	Na salt	5 × 10 ⁻⁶	0.549
Laurylbenzenesulfonate	Na salt	5 × 10 ⁻⁶	0.547
ClO ₄ ⁻	NaClO ₄	1 × 10 ⁻⁶	0.557
Ti ₄ ⁺	TiCl ₄	1 × 10 ⁻⁶	0.551

* Sample solution 10 cm³ organic phase 5 cm³; phosphorus 0.366 μg; measured against reagent blank. † Tolerance limit

the chloride concentration in the wash should be within ±15% of that in the sample. The use of saline standards is optional, but the use of saline control solutions is mandatory. Using good equipment, down to 0.02 mg/l phosphate can be determined by such procedures. For chloride contents above 18 000 mg/l the chloride content of the wash should be within ±5% of that in the sample.

Flynn and Meehan [191] have described a solvent extraction phosphomolybdate method using isoamyl alcohol for monitoring the concentration of ³²P in sea and coastal waters near nuclear generating stations.

Deans [192] have proposed a method for the colorimetric determination of traces of phosphorus with molybdenum blue, making use of the laser-induced thermal lensing effect. The procedure is described, and the results obtained on samples of sea water and lake water are presented.

Figure 2.7. Interference by chloride in the auto-analyser determination of phosphate

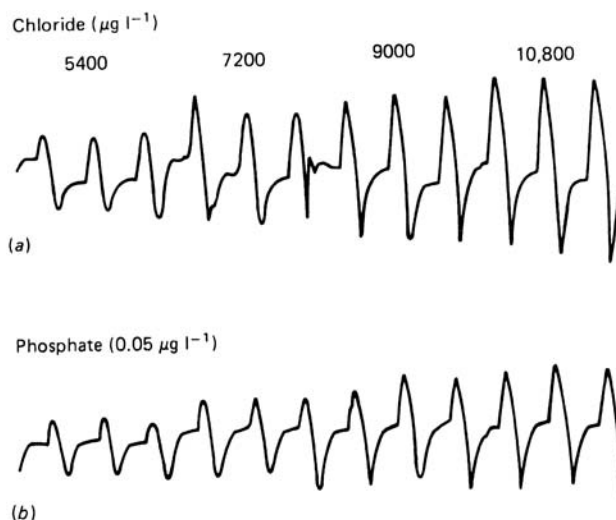

In this method an Ar^+ laser-pumped rhodamine 101 laser was used as the heat and probe source. The signal from a silicon photocell with a 1 mm^2 photosensitive surface, which was used as a laser radiation detector, was processed with an inexpensive personal computer. The detector limit is 5 pg of phosphorus/ml.

Yoshimura et al. [193] carried out microdeterminations of phosphate by gel-phase colorimetry with molybdenum blue. In this method phosphate reacted with molybdate in acidic conditions to produce 12-phosphomolybdate. The blue species of phosphomolybdate were reduced by ascorbic acid in the presence of antimony ions and adsorbed on to Sephadex G-25 gel beads. Attenuation at 836 and 416 nm (adsorption maximum and minimum wavelengths) was measured, and the difference was used to determine trace levels of phosphate. The effect of nitrate, sulfate, silicic acid, arsenate, aluminium, titanium, iron, manganese, copper, and humic acid on the determination were examined.

Eberlein and Kattner [194] described an automated method for the determination of orthophosphate and total dissolved phosphorus in the marine environment. Separate aliquots of filtered seawater samples were used for the determination orthophosphate and total dissolved phosphorus in the concentration range 0.01 – 5 µg/l phosphorus. The digestion mixture for total dissolved phosphorus consisted of sodium hydroxide (1.5 g), potassium peroxodisulfate (5 g) and boric acid (3 g) dissolved in doubly distilled water (100 ml). Seawater samples (50 ml) were mixed with the digestion reagent, heated under pressure at 115 – 120 °C for 2 h , cooled, and stored before determination in the auto-analyser system. For total phosphorus, extra ascorbic acid was added to the aerosol water of the autoanalyser manifold before the reagents used for the molybdenum blue reaction were added. For measurement of orthophosphate, a phosphate working reagent composed of sulfuric acid, ammonium molyb-

date, ascorbic acid, and antimony potassium tartrate solution was prepared. Up to 30 samples per hour could be analysed.

Airey et al. [195] have described a method for the removal of sulfide prior to the determination of phosphate in anoxic estuarine waters. Mercury (II) chloride was used to precipitate free sulfide from samples of anoxic water. The sulfite-free supernatant liquid was used to estimate sulfide by measuring the concentration of unreacted mercury (II), as well as to determine phosphate by the spectrophotometric method in which sulfide interferes. The detection limit for phosphate was 1 $\mu\text{g/l}$.

2.22.3

Ion Chromatography

Tyree and Bynum [132] have described an ion chromatographic method for the determination of phosphate and nitrate in seawater.

2.23

Propionate

2.23.1

Ion Chromatography

See Sect. 2.1.1.

2.24

Pyruvate

2.24.1

Ion Chromatography

See Sect. 2.1.1.

2.25

Selenate/Selenite

2.25.1

Fluorometric Method

Itoh et al. [196] determined selenium (IV) in sea and estuarine waters by an anion-exchange resin modified with bismuthiol (II) and diamionaphthalene fluorophotometry. An Amberlite IRA-400 anion exchange resin was modified by mixing with an aqueous solution of bismuthiol (II) to give 0.2 mmol per g of

resin. Sample solution was eluted through a column packed with the modified resin.

Selenium (IV) adsorbed as selenotrisulfate was then eluted from the column with either 0.1 M penicillamine or 0.1 M cysteine. The eluate was then subjected to an acid digestion procedure to reduce selenium to the tetravalent state with diaminonaphthalene for fluorometric determination. Approximate agreement with the tellurium coprecipitation method was obtained. The application of both methods to the analysis of estuarine waters permitted the separate determination of both selenium (IV) and selenium (VI), since the tellurium coprecipitation methods did not differentiate between the two species.

2.26

Silicate

2.26.1

Spectrophotometric Methods

Silicon is an essential and, in some cases, a growth-limiting micronutrient for marine organisms that form siliceous skeletons [197]. Concentrations of available silicon are often low ($< 1 \mu\text{M}$) in surface waters of high productivity. Although most of the silicon is recycled near the surface, a fraction reaches the sediment surface, where it may dissolve. As a result, deep waters may have dissolved silicon concentration as high as $200 \mu\text{M}$. Upwelling returns the dissolved silicon to the surface, and the cycle is repeated. Dissolved silicon is an important species to monitor because of its influence on plankton growth [197] and because of its use as a tracer of water mass movement [198].

Various approaches to the analysis of dissolved silicon have been tried. Most of them are based on the formation of β -molybdosilic acid [199–203]. Dissolved silicon exists in seawater almost entirely as undissociated orthosilicic acid. This form and its dimer, termed “reactive silicate”, combine with molybdosilic acid to form α - and β -molybdosilic acid [180]. The molybdosilic acid can be reduced to molybdenum blue, which is determined photometrically [206]. The photometric determination of silicate as molybdenum blue is sufficiently sensitive for most seawater samples. It is amenable to automated analysis by segmented continuous flow analysers [206–208]. Most recent analyses of silicate in seawater have, therefore, used this chemistry. Furthermore, reactive silicate is probably the only silicon species in seawater that can be used by siliceous organisms [204].

Spencer and Brewer [111] have reviewed methods for the determination of silicate in seawater. Various workers [209–212] have studied the application of molybdosilicate spectrophotometric methods to the determination of silicate in seawater. In general, these methods give anomalous results due, it is believed, to erratic blanks and uncertainty regarding the structure of the silicomolybdate formed.

Brzelinski and Nelson [214] have described a solvent extraction procedure for the spectrophotometric determination of nanomolar concentrations of silicic acid in seawater.

β -silicomolybdic acid was formed by the reaction of silicic and molybdic acids at low pH. The combined acid was extracted into *n*-butanol and reduced with a mixture of *p*-methylaminophenol sulfate and sulfite. After phase separation, the samples were cleaned by chilling in ice followed by centrifuging, and the colour was evaluated spectrophotometrically at 810 nm. The molar absorbance of the mixed acid was 229 000 in seawater and the precision was ± 2.5 nmol/l silicon for concentrations less than or equal to standard aqueous analyses. Sensitivity in seawater was 70% of that in distilled water because of a significant salt effect. Natural concentrations of arsenate, arsenite, and germanic acid caused negligible interference. Phosphate interference was equivalent to 10^{-12} nmol/l silicon over a broad range of phosphate concentrations.

2.26.2

Flow Injection Analysis

Flow injection analysis is a rapid method of automated chemical analysis that allows for quasi-continuous recording of nutrient concentrations in a flowing stream of seawater. The apparatus used for flow injection analysis is generally less expensive and more rugged than that used in segmented continuous flow analysis. A modified flow injection analysis procedure, called reverse flow injection analysis, was adopted by Thompson et al. [213] and has been adapted for the analysis of dissolved silicate in seawater. The reagent is injected into the sample stream in reverse flow injection analysis, rather than vice versa as in flow injection analysis. This results in an increase in sensitivity.

This analytical procedure is based on an optimum analysis condition for segmented continuous flow analysis. The sample is combined with a molybdate solution at a pH between 1.4 and 1.8 to form the β -molybdosilicic acid. After an appropriate time for reaction, a solution of oxalic acid is added, which transforms the excess molybdate to a non-reducible form. The oxalic acid also suppresses the interference from phosphate by decomposing phosphomolybdic acid. Finally, a reductant is added to form molybdenum blue. Both ascorbic acid and stannous chloride were tested as reductants.

In the determination of silicate, a detection limit of $0.5 \mu\text{mol/l}$ was achieved with a relative precision of better than 1% at concentrations above $10 \mu\text{moles silicon/l}$.

2.26.3

Ion Exclusion Chromatography

Hioki et al. [215] have described an on-line determination of dissolved silica in seawater by ion exclusion chromatography in combination with inductively coupled plasma emission spectrometry.

This method was developed as a second independent method to complement the usual colorimetric procedure in the determination of a certified concentration of dissolved silica in a seawater reference material. Ion exclusion affords a separation of the dissolved silica not only from major seawater cations but also from potentially interfering anions. The detection unit limit, conservatively estimated at 2.3 ng/g Si (0.08 μm), is superior to that achievable by direct analysis using inductively coupled plasma emission spectrometry.

Other studies on the application of this technique have been carried out [216–219].

2.27 Sulfide

2.27.1 Gas Chromatography

Cutter and Oatts [220] determined dissolved sulfide and studied sedimentary sulfur speciation using gas chromatography in conjunction with a photoionisation detector. The determination of dissolved sulfide and sedimentary sulfur is important to studies of trace element cycling in the aquatic environment. A method employing selective generation of hydrogen sulfide, liquid-nitrogen-cooled trapping, and subsequent gas chromatographic separation/photoionisation detection, has been developed for such studies. Dissolved sulfide is determined via acidification and gas stripping of a water sample, with a detection limit of 12.7 nM and a precision of 1% (relative standard deviation). With preconcentration steps the detection limit is 0.13 nM. The detection limit for those sulfur species is 6.1 μg of S/g, with the precision not exceeding 7% (relative standard deviation). This method is rapid and free of chemical interferences; field determinations are possible.

Leck and Bagander [221] determined reduced sulfide compounds (hydrogen sulfide, methyl mercaptan, carbon disulfide, dimethyl sulfide, and dimethyldisulfide) in water by gas chromatography using flame detection. Detection limits ranged from 0.2 ng/l for carbon disulfide to 0.6 ng/l for methyl mercaptan. Hydrogen sulfide was determined at the 1 ng/l level.

2.27.2 Capillary Isotachoelectrophoresis

Fukishi and Hiroy [222] determined sulfide in seawater by this technique. The method is based on the generation of hydrogen sulfide by the addition of sulfuric acid to the water sample. The gas permeated through a microporous polytetrafluoroethylene (PTFE) tube, and was collected in a sodium hydroxide solution. The carbon dioxide in the permeate was removed by adding a barium cation-exchange resin to the sodium hydroxide solution. Injection into the

isotachopheresis apparatus followed. A linear graph for sulfide concentrations of up to 2 mg/l was obtained.

2.28

Sulfate

2.28.1

Titration Method

Sulphate has been determined in seawater by photometric titration with hydrochloric acid in dimethyl sulfoxide [223]. The sample (5 ml) is slowly added to dimethyl sulfoxide (230 ml) and titrated with 0.02 M hydrochloric acid (standardised against sulfate) with bromo-cresol green as indicator. Since borate, carbonate, and bicarbonate interfere, a separate determination of alkalinity is necessary.

Lebel [224] has described an automated chelometric method for the determination of sulfate in seawater. This method utilises the potentiometric end-point method for back titration of excess barium against EDTA following precipitation of sulfate as barium sulfate. An amalgamated silver electrode was used in conjunction with a calomel reference electrode in an automatic titration assembly consisting of a 2.5 ml autoburette and a pH meter coupled to a recorder. Recovery of added sulfate was between 99 and 101%, and standard deviations of successive analyses were less than 0.5 of the mean.

2.28.2

Inductively Coupled Plasma Atomic Emission Spectrometry

Inductively coupled plasma atomic emission spectrometry has also been used to determine sulfate directly in non-saline waters [225].

By monitoring the 180.73 nm sulfur line, it was possible to detect 0.08 mg/l sulfate with a precision of 0.8% relative standard deviation at the 200 mg/l sulfate level. Instrument operating conditions are shown in Table 2.5.

Of the elements characteristically present as major components of non-saline waters, only calcium produced a slight interference. A weak calcium line at approximately 190.73 nm partially overlaps the sulfur line such that 1000 mg/l Ca produces an apparent signal of 25 mg/l sulfate. Correction for this interference is easily achieved by establishing the relationship between calcium concentration and apparent sulfate signal, and inserting this information in the controlling software. The effect of calcium was then automatically subtracted during the measurement of the sample.

Non-saline water samples are normally acidified to stabilise them during storage. There is an effect due to hydrochloric acid concentration on the sulfur emission signal. This effect is conveniently overcome by making the acid content of samples and standards identical at, for example, 1 vol%.

Table 2.5. Plasma system components, and operating conditions [225]

Spectrometer	ARL 3400 C Quantovac; 1 m Paschen-Range monuing; grating ruled 1080 lines mm ⁻¹ , 0.309 nm mm ⁻¹ reciprocal linear dispersion (3rd order). Primary slit width 20 μm, secondary slit 50 μm, Hamamatsu R-306 photomultiplier tube
Wavelength	180.73 nm, 3rd order
Readout	Digital readout of mean signal from three – 10 s integrations
Frequency	27.12 MHz
Forward power	1080 W
Reflected power	5 W
Observation height	17 mm above load coil
Argon flow rates	Coolant 11 L/min, plasma 1.2 L/min, carrier 1 L/min, light path purge 1.5 L/min
Nebuliser	Concentric glass, JE Meinhard model TR-30-A3

The accuracy of the inductively-coupled plasma procedure was assessed by analysing waters of known sulfate composition, and by comparing measured sulfate values for a wide range of samples with those obtained for the same waters by an automated spectrophotometric procedure. Good agreement is obtained between the derived sulfate measurements and the normal values for International Standard Sea Water and an EPA Quality Control Standard.

2.28.3

Polarography

Polarography has also been used to determine sulfate [226]. In this method sulfate is precipitated as lead sulfate in a 20% alcoholic medium, followed by polarographic determination of the excess lead. It is claimed that there is little interference in this method; 25–30 samples can be analysed in a five hour period.

In this procedure up to 70 ml seawater, 10 ml 0.01 M lead nitrate, 20 ml 95% ethanol, 0.2 ml of 0.1% methyl red maximum current suppressor, and two drops of 3 M nitric acid are added to a 100 ml volumetric flask, the contents of which are then diluted to 100 ml with distilled water.

The dropping mercury electrode had a drop time of 3–4 s under an open head of 50 cm Hg. A saturated calomel electrode was the reference electrode. Before recording, the solutions were shaken well. After recording, the electrodes were well rinsed with distilled water and wiped dry. A starting potential of 0.2 V was used and the solutions were degassed with dry nitrogen for 2 min prior to recording. A full-scale sensitivity of 10 μA was used.

As an indication of the accuracy of the technique the correlation coefficients for the calibration curves indicate a precision of 0.2% or better. The standard deviation of the measurement samples is 0.70%.

The precision of the technique indicates its suitability for sulfate analysis. The technique appears not to be subject to any interference normally present in seawater samples.

2.28.4

Ion Chromatography

Singh et al. [227] have determined sulfate in deep sub-surface waters by suppressed ion chromatography.

2.29

Valerate

2.29.1

Ion Chromatography

See Sect. 2.1.1.

2.30

Multianion Analysis

2.30.1

Spectrophotometric Methods, Phosphate, Arsenate, Arsenite, and Sulfide

Nasu and Kan [228] determined phosphate, arsenate, and arsenite in non-saline water by flotation spectrophotometry and extraction indirect atomic absorption spectrometry, using malachite green as an ion-pair reagent. A floated (between aqueous and organic phase) ion pair of malachite green with molybdophosphate was dissolved by the addition of methanol to the organic layer. Phosphate and arsenate were determined by measuring absorbance of the organic phase. An oxidative (potassium dichromate) or a reductive (sodium thiosulfate) reaction of arsenic was used for the determination of phosphate, arsenate, and arsenite. A positive interference effect was observed in the presence of large amounts of silicon. This was overcome by acidification with concentrated hydrochloric acid. The method was applied to samples of hot spring water, sea water, and ground water, with almost complete recovery of added amounts (0.04–0.2 $\mu\text{g/ml}$).

Johnson and Pilson [229] have described a spectrophotometric molybdenum blue method for the determination of phosphate, arsenate, and arsenite in estuary water and sea water. A reducing reagent is used to lower the oxidation state of any arsenic present to +3, which eliminates any absorbance caused by molybdoarsenate, since arsenite will not form the molybdenum complex. This results in an absorbance value for phosphate only.

A commonly used procedure for the determination of phosphate in sea water and estuarine waters involves the formation of the molybdenum blue complex at 35–40 °C in an autoanalyser followed by spectrophotometric evaluation of the resulting colour. Unfortunately when applied to sea water samples, depending on the chloride content of the sample, peak distortion or even negative peaks occur, which make it impossible to obtain reliable phosphate values. This effect can be overcome by the replacement of the distilled water used in such methods by a solution of sodium chloride of an appropriate concentration related to the chloride concentration of the sample (see Sect. 2.22.2).

Airey et al. [230] have described a method for the removal of sulfide prior to the determination of phosphate in anoxic estuarine waters. Mercury (II) chloride was used to precipitate free sulfide from samples of anoxic water. The sulfide-free supernatant liquid was used to estimate sulfide by measuring the concentration of unreacted mercury (II), as well as to determine phosphate by a spectrophotometric method in which sulfide interferes. The detection limit for phosphate was 1 µg/l.

2.30.2

Electrostatic Ion Chromatography, Bromide, Nitrate, and Iodide

In a series of methods [231–237] employing stationary phases coated with zwitterionic surfactants, (i.e., those containing both positively and negatively charged functional groups but carrying no formal net charge), it has been demonstrated that inorganic anions can be separated using pure water as eluent, with unique separation selectivity. This method has been termed electrostatic chromatography: the separation has been attributed to a simultaneous electrostatic attraction and repulsion mechanism occurring at both the positive and the negative charges on the stationary phase. A drawback of electrostatic ion chromatography is that when the sample contains multiple anions and cations, each analyte anion may be eluted as more than one peak, with each peak being a specific combination of the anion with one of the cations of the sample. Recently, Hu and Haddad [238] showed that addition of a small quantity of a suitable electrolyte to the eluent causes analyte anions to be eluted only as a single peak, irrespective of the number and type of cations in the sample. In further studies, Hu et al. [239] investigated the separation mechanism in more detail and have applied the method to the determination of nitrate, bromide, and iodide in seawater.

The determination of nitrate, bromide, and iodide in seawater is of importance to oceanographic research [240–242]. Ion chromatography is generally inapplicable to this analysis for several reasons. First, the large number of matrix ions (chloride, sulfate) saturates the active sites of the stationary phase and thereby impedes the separation of the target analytes. Second, the high ionic strength of the sample causes self-elution of the sample band during injection, leading to peak broadening and loss of separation efficiency. Third, the levels

of the target analytes are often very low, so that detection becomes a major problem, especially when the eluted peaks are poorly defined in shape.

To overcome these difficulties, Ito and Sunahara [102] suggested the use of the matrix ions as the eluent ions, for example the use of relatively high concentrations of sodium chloride solution.

In the most recent method described by Hu et al. [239] for the direct determination of ultraviolet-absorbing inorganic anions in saline matrixes, an octadecylsilica column modified with a zwitterionic surfactant [3-(*N,N*-dimethylmyristylammonio)propanesulfate] is used as the stationary phase, and an electrolytic solution is used as the eluent. Under these conditions, the matrix species (such as chloride and sulfate) are only retained weakly and show little or no interference. It is proposed that a binary electrical double layer is established by retention of the eluent cations on the negatively charged (sulfonate) functional groups of the zwitterionic surfactant, forming a cation-binary electrical double layer.

2.30.3

Miscellaneous

Determinations of the so-called “micronutrients”, (e.g., nitrate, phosphate, and dissolved silica), in seawater are among the most commonly performed analyses in oceanographic research and survey work. Surprisingly, there exists no certified reference material that can be used to check the accuracy of such analyses, although intercomparison exercises have been conducted on a regular basis [243]. The lack of seawater certified reference material for micronutrients can be attributed both to the difficulty of preparing a suitable material with an adequate shelf life [244, 245] and to the dearth of independent methods available for the determinations.

The National Research Council of Canada has undertaken a project, in collaboration with Bedford Institute of Oceanography of the Canadian Department of Fisheries and Oceans, to address the need for a seawater certified reference material for micronutrients with the initial objective being the preparation of a material with certified values for nitrate, phosphate, and dissolved silica.

2.31

pH

Sedijl and Lu [246] have described a colorimetric method using optical deflection for the determination of the pH of seawater.

Yaakov and Ruth [247, 248] have described an improved *in situ* pH sensor for oceanographic and limnological applications. They report that an accuracy of 0.002 pH units can be achieved.

Khoo et al. [249] have reported on the measurement of standard potentials, hence hydrogen ion concentrations, in seawaters of salinities between 20 and 45‰ at 5–40 °C.

2.32

Suspended Solids

Suspended solids determinations on non-saline samples are a routine procedure that does not present any problems. The solids, after filtration on a 0.45 µm glass fibre disc are dried at 105 °C to obtain the moisture content and at 450–500 °C to obtain the organic content. However, the application of this procedure to saline samples does present some problems, owing to errors caused by the occlusion of sea salts on the filter disc and the filtered solids. One innovation that has been adopted to correct for high solids contents on such samples has been to filter the sample through a double layer of glass fibre paper. The weight increase of the lower paper is due to the occluded salts whilst that on the top paper is due to salts plus sample solids. The corrected solids content is then obtained by subtracting the weight increase of the lower disc from that of the upper disc. Unfortunately, results obtained by this modified

Table 2.6. Anion preconcentration (from author's own files)

Anion	Preconcentration method	Analytical finish	Detection limit (µg/l)	Section	Reference
SbO ₄ AsO ₄ AsO ₃ CrO ₄	Solvent extraction	Spectrophotometric	–	2.30.1	[228]
	Fe(OH) ₃ coprecipitation	Atomic absorption spectrometry	0.04	2.10.1	[35–38]
	Immobilised diphenyl carbazone	Atomic absorption spectrometry	–	2.10.1	[250]
F	Solvent extraction of ternary lanthanum alizarin complexone fluoride	Atomic emission spectrometry	0.6	2.11	[251]
MoO ₄	Adsorption of Tiron complex on anion exchange resin	–	–	2.16	[252]
	Adsorption on basic anion exchange resin	Atomic absorption spectrometry	< 10	2.16	[253]
Perrhenate	Adsorption on De-Acidite anion exchange resin	Neutron activation analysis	0.06	2.20	[176]

procedure are still unreliable, becoming more so at higher salt concentrations in the sample.

A further simple innovation gives much more reliable solids results. In this the glass fibre disc mounted in its porcelain, glass, or plastic holder is first wetted with distilled water, and then the sample filtered through and washed with several small portions of distilled water without allowing the disc to become dry. It is believed that filling the air spaces in the annulus of the disc trapped in the holder with distilled water is the reason why better results are obtained by this procedure.

2.33

Anion Preconcentration

Methods of improving the detection limits for anions by preconcentration are reviewed in Table 2.6.

References

1. Yang X-H, Lee C, Schanton MI (1993) *Anal Chem* **65**:857
2. Gran G (1952) *Analyst* **77**:661
3. Culberson C, Pytowicz RM, Hawley JE (1970) *J Mar Res* **28**:15
4. Pearson F (1981) *J Water Pollution Control* **53**:1243
5. Dickson AG (1981) *Deep-Sea Res* **28A**:609
6. Sass E, Ben-Yaakov S (1977) *Mar Chem* **5**:183
7. Bates RG (1964) *Determination of pH - theory and practice*. Wiley, New York
8. Ben-Yaakov S, Lorch Y (1983) *Mar Chem* **13**:293
9. Ben-Yaakov S, Raviv R, Guterman H, Davan A, Lazar B (1982) *Talanta* **29**:267
10. Keir RS, Kounaves SP, Sirino AL (1977) *Anal Chim Acta* **91**:181
11. Johansson A, Johnansson S, Gran G (1972) *Analyst* **108**:1086
12. Stuart WA, Lister AR Report from the UK Atomic Energy Authority AERE-M2250-5PP, AERE, Harwell, UK
13. Hansson I, Jagner D (1973) *Anal Chim Acta* **65**:363
14. Haywood MG, Riley JP (1976) *Anal Chim Acta* **219**:85
15. Chaime F, Zeitlin H (1974) *Separ Sci* **1**:9
16. Johnson O (1972) *Anal Abst* **2768**:22
17. Sato S (1983) *Anal Chim Acta* **151**:465
18. Macalady DL, Carpenter DH, Moore CA (1977) *Science* **195**:1335
19. Carpenter JH (1965) *Limnol Oceanogr* **10**:135
20. Lewin M, Avrahani M (1950) *J Am Chem Soc* **47**:419
21. Kolthoff JM, Yutzy A (1937) *Ind Eng Chem* **9**:75
22. Rose O, Cuttita A (1968) *Advanced X-Ray Analysis* **11**:23
23. Basel CL, Defreeze JD, Whittemore DO (1982) *Anal Chem* **54**:2090
24. Walters FH (1984) *Anal Lett* **17**:1681
25. Sichére M-C, Cesbron F, Zuppi G-M (1978) *Anal Chim Acta* **28**:299
26. Fukushi K, Hiro K (1987) *Bunseki Kagaku* **36**:712
27. Jagner D, Aren K (1970) *Anal Chim Acta* **52**:491
28. Jagner D (1970) *Anal Chim Acta* **50**:15

29. Grasshoff K, Wenck A (1972) *Mercantile Journal Cons Perm International* 522:34
30. Noborn O (1972) *Japan Analyst* 780:21
31. Meyer RE, Dosey FA, Lontz PH (1968) *J Electroanal Chem* 99:19
32. Wilson TRS (1971) *Limnol Oceanogr* 16:581
33. Batley GE, Matousek JP (1980) *Anal Chem* 52:1570
34. De Jong GJ, Brinkman UAT (1978) *Anal Chim Acta* 98:243
35. Cranston RE, Murray JW (1978) *Anal Chim Acta* 99:275
36. Cranston RE, Murray JW (1980) *Limnol Oceanogr* 25:1104
37. Mullins TL (1984) *Anal Chim Acta* 165:97
38. Nakayama E, Toroko H, Fujinaga T (1981) *Anal Chim Acta* 131:247
39. Nakayama E, Kuwamoto H, Tokoro H, Tsurubo S, Fujinaga T (1981) *Anal Chim Acta* 130:289
40. Grimaud D, Michard G (1974) *Mar Chem* 2:229
41. Nakayama E, Kuwamoto T, Tokoro H, Tsurubo S, Fujinaga T (1981) *Anal Chim Acta* 130:290
42. Nakayama E, Kuwamoto T, Tsurubo S, Fujinaka T *Anal Chim Acta* (1981) 130:401
43. Nakayama E, Kuwamoto T, Tsurubo S, Fujinaka T *Anal Chim Acta* (1981) 130:402
44. Ishibashi M, Shigematsu T (1950) *Bull Inst Chem Res Kyoto University* 23:59
45. Chuecas L, Riley JP (1966) *Anal Chim Acta* 35:240
46. Kuwamoto T, Murai S (1970) *Preliminary Report of the Hakuho-maru Cruise KH-68-4*, Ocean Research Institute University, Tokyo, 72
47. Fukai R (1967) *Nature* 213:901
48. Fukai R, Vas D (1967) *Journal Oceanographic Society, Japan* 23:298
49. Yamamoto T, Kadowski S, Carpenter JH (1974) *Geochem J* 8:123
50. Ahern F, Eckert JM, Payne NC, Williams KL (1985) *Anal Chim Acta* 175:147
51. Fletsch RA, Richards FA (1970) *Anal Chem* 42:1400
52. Greenhalgh R, Riley JP (1961) *Anal Chim Acta* 25:679
53. Brewer PG, Spencer DW, Wilkniss (1970) *Deep-Sea Res* 17:1
54. Warner TB (1969) *Science* 165:178
55. Windom HI (1971) *Limnol Oceanogr* 16:806
56. Orion, *Research Analytical Methods Guide 6th Edition* (1973)
57. Anfalt T, Jagner D (1971) *Anal Chim Acta* 53:13
58. Rix CJ, Bond AH, Smith JD (1976) *Anal Chem* 48:1236
59. Barendrecht E (1967) In: *Electroanalytical Chemistry* (ed AJ Bond) Volume 2, Marcel Dekker, New York, p. 53
60. Brand HJD, Rechnitz GA (1970) *Anal Chem* 42:1172
61. Baumann EW (1970) *Anal Chim Acta* 42:127
62. Craggs A, Moody GJ, Thomas JDR (1974) *J Chem Educ* 81:541
63. Liberti A, Mascini M (1969) *Anal Chem* 41:676
64. Baumann EW (1971) *Anal Chim Acta* 54:189
65. Frani MS, Ross JW (1966) *Science* 154:1553
66. Riley JP, Chester R (1971) In: *Introduction to Marine Chemistry* (eds Riley JP, Chester R) Academic Press, London, p. 70–80
67. Bond AM, Hefter G (1971) *J Inorg Nucl Chem* 33:429
68. Greenhalgh R, Riley JP (1961) *Anal Chim Acta* 25:679
69. Warner TB (1971) *Deep-Sea Res* 18:1255
70. Special Publication No17 (1964) The Chemical Society, UK
71. Ke PJ, Regier LW (1971) *Anal Chim Acta* 53:23
72. Ke PJ, Regier LW (1970) *Anal Abst* 19:2392
73. Wilkniss PK, Linnebon WJ (1968) *Limnol Oceanogr* 13:530

74. Gomez MG, Palacios Corvillo MA, Camara Rica C (1988) *Analyst* **113**:1109
75. Kieber DG, Vaughan GM, Mopper K (1988) *Anal Chem* **60**:1654
76. William PM, Robertson K (1980) *Journal of Water Pollution Control Federation* **52**:2167
77. Truesdale VW (1978) *Mar Chem* **6**:253
78. Truesdale VW (1978) *Mar Chem* **6**:150
79. Truesdale VW (1974) *Deep-Sea Res* **21**:761
80. Truesdale VW, Smith JS (1979) *Mar Chem* **7**:133
81. Truesdale VW, Smith JS (1975) *Analyst* **100**:111
82. Herring JR, Liss PS (1974) *Deep-Sea Res* **21**:777
83. Schnepfe MM (1972) *Anal Chim Acta* **58**:83
84. Tsunogai S (1971) *Deep-Sea Res* **18**:913
85. Tsunogai S, Henmi T (1971) *J Oceanogr (Japan)* **27**:67
86. Wong GTF, Brewer PG (1976) *Anal Chim Acta* **81**:81
87. Smith JD, Butler ECV, Airey D, Sandars G (1990) *Mar Chem* **28**:353
88. Wong GTF, Zhang L (1992) *Cont Shelf Res* **12**:717
89. Nakayama E, Kimoto T, Okazaki S (1985) *Anal Chem* **57**:1160
90. Nakayama E, Kimoto T, Isshiki K, Sohrin Y, Okazaki S (1989) *Mar Chem* **27**:105
91. Takayanagi K, Wong GTF (1986) *Talanta* **33**:451
92. Luther III GW, Swartz CB, Ullman WJ (1988) *Anal Chem* **60**:1721
93. Jickells TD, Biyd SS, Knap AH (1988) *Mar Chem* **24**:61
94. Wong GTF, Takayanagi K, Todd JF (1985) *Mar Chem* **17**:177
95. McTaggart AR, Butler ECV, Haddad PR, Middleton JH (1994) *Mar Chem* **7**:159
96. Tsunogai S, Sase T (1969) *Deep-Sea Res* **10**:489
97. Crompton TR (1977) *Chemical Analysis of Organo-metallic Compounds*, Volume 5, Academic Press, New York, p. 132
98. Sugawara A (1956) *Anal Abst* **3**:1169
99. Matthews AD, Riley JP (1970) *Anal Chim Acta* **51**:295
100. Shizuo T (1971) *Anal Chim Acta* **55**:444
101. Butler ECV, Gershey RM (1984) *Anal Chim Acta* **164**:153
102. Ito K, Sunahara H (1988) *Bunseki Kagaku* **37**:292
103. Ito K (1997) *Anal Chem* **69**:3029
104. Buchberger W, Huemer P, Winsauer K (1985) *Z Wasser Abwass Fors* **18**:194
105. Krishnamoorthy KR, Iyer RK (1987) *Proceedings of the Indian Academy of Science, Chemical Sciences* **98**:177
106. Varma KK, Jaia A, Varma A (1992) *Anal Chem* **64**:1484
107. Yoshida I, Taekshita R, Ueno K (1987) *Kenkyu, Hokaku-Kuwamoto Kogyo Daigaku* **12**:159
108. Hara H, Okazaki S (1984) *Analyst* **109**:1317
109. Van Staden JF (1985) *Fresen Z Anal Chem* **322**:336
110. Basson WP, Van Staden JF (1981) *Water Res* **15**:333
111. Spencer DW, Brewer PG (1970) *Crit Rev Solid State* **1**:409
112. Matsunaga K, Nishimura M (1974) *Anal Chim Acta* **73**:204
113. Matsunaga K, Nishimura M (1969) *Anal Chim Acta* **45**:350
114. Malhotra SK, Zanoni AD (1970) *J Am Water Works Assoc* **62**:568
115. Lambert RS, Du Bois RJ (1971) *Anal Chem* **43**:955
116. Joos MH (1984) *Water Res* **18**:643
117. Mubarek A, Howald RA, Woodruff IR (1977) *Anal Chem* **49**:857
118. Mertens J, Massart DL (1971) *Bulletin of the Belgium Chemical Society* **80**:151
119. Hoather RC (1953) *Applications of Spectrophotometry for the Examination of Water Proceedings of the Society of Water Treatment and Examination* **2**:9

120. Hoather RC, Rackman RF (1959) *Analyst* **84**:548
121. Goldman E, Jacobs RJ (1961) *J Am Water Works Assoc* **53**:187
122. Morries E (1971) *Proceedings of the Society of Water Treatment and Examination* **20**:132
123. Brown L, Bellinger EL (1978) *Water Res* **12**:223
124. Gorside C (1982) *Mar Chem* **11**:159
125. Cox DJ, Hill NC (1985) *Estuarine Coastal and Shelf Science* **21**:127
126. Anderson L (1979) *Anal Chim Acta* **110**:123
127. Ranger CB (1981) *Anal Chem* **53**:20A
128. Ruzicka J, Hansen EH (1978) *Anal Chem* **99**:37
129. Johnson KS, Petty RL (1983) *Limnol Oceanogr* **28**:1260
130. Hyde DJ, Hill NC (1985) *Estuar Coast Shelf Sci* **21**:127
131. Van den Berg CMG (1988) *Anal Chim Acta* **212**:31
132. Tyree SY, Bynum MAO (1984) *Limnol Oceanogr* **29**:1337
133. Dahiloef I, Svensson O, Tortensson C (1997) *J Chromatogr A* **771**:163
134. Sigman DM, Casciotti KL, Andreani C, Barford C, Galanta M, Böhlke JK (2001) *Anal Chem* **73**:4145
135. Sigman DM, Altabet MA, Michener RH, McCorkle DC, Fry B, Holmes RM (1997) *Mar Chem* **57**:227
136. Amberger A, Schmidt H-L (1987) *Geochim Cosmochim Acta* **51**:2699
137. Revesz K, Böhlke JK, Yoshinari Y (1997) *Anal Chem* **69**:4375
138. Silva SR, Kendall C, Wilkison DH, Ziegler AC, Chang CCY, Avanzino RJ (2000) *J Hydrol* **228**:22
139. Liu KK, Su MJ, Hseuh CR, Gong GC (1996) *Mar Chem* **54**:273
140. Zumft WG (1997) *Microbiol Mol Biol Rev* **61**:553
141. Greenberg EP, Becker GE (1997) *Can J Microbiol* **23**:903
142. Cerda A, Oms MT, Forteza R, Cerda V (1998) *Anal Chim Acta* **371**:63
143. Sakamoto GM, Friederich GE, Service SK, Chavez FP (1996) *Deep-Sea Res* **43**:1763
144. Spencer DW, Brewer PG (1970) *Crit Rev Solid State Sci* **1**:409
145. Pett SKW (1979) *Water Res Technical Report* TR 120
146. Matsunaga K, Oyama T, Nishimura M (1972) *Anal Chim Acta* **58**:228
147. Gianguzza A, Orecchio S (1982) *Inquinamento* **24**:94
148. Wada E, Hattori A (1971) *Anal Chim Acta* **56**:233
149. Fogg AG, Bsebsu NK, Abdalla MA (1982) *Analyst* **107**:1040
150. Poeston T, Zainal K, Anderson S, Bury SJ (1998) *Rapid Commun Mass Spec* **12**:423
151. Van den Berg CMG, Li H (1988) *Anal Chim Acta* **212**:31
152. Aminot A, Kerouel R (1998) *Mar Chem* **61**:203
153. Bajic SJ, Jaselskis B (1985) *Talanta* **32**:115
154. Nagashima K, Matsumoto M, Suzuki S (1985) *Anal Chem* **57**:2065
155. Department of the Environment/National Water Council Study Committee of Analysts, *Methods for the examination of water and associated materials*, HMSO, London (1981) 61 pp (RP2B:CENV)
156. Mullin JB, Riley JP (1955) *Anal Chim Acta* **12**:464
157. Chow TJ, Johnstone MS (1962) *Anal Chim Acta* **27**:441
158. Bernard M, Macchi G, *Automation in analytical chemistry*, Technicon Symposia, Mediad, New York (1965) 252
159. Morris AW, Riley JP (1963) *Anal Chim Acta* **29**:272
160. Grasshof K (1964) *Kieler Meersforsch* **20**:5
161. Wood ED, Armstrong FA, Richards FA (1967) *J Mar Biol Assoc* **47**:23
162. Henriksen A, Selmer-Olsen AR (1970) *Analyst* **95**:514

163. Armstrong EAJ, Sterus CR, Strickland JDH (1967) *Deep-Sea Res* **14**:381
164. Chow TJ, Johnstone MS (1962) *Anal Chim Acta* **27**:441
165. Morris AW, Riley JP (1963) *Anal Chim Acta* **29**:272
166. Ruzicka J, Hansen EH (1975) *Anal Chim Acta* **78**:145
167. Nydahl F (1976) *Talanta* **23**:349
168. Anderson L (1979) *Anal Chim Acta* **110**:123
169. Shinn MB (1941) *Ind Eng Chem Anal Ed* **13**:33
170. Hansen EH, Ruzicka J (1976) *Anal Chim Acta* **87**:353
171. Strickland JDH, Parsons TR (1968) *A Practical Handbook of Seawater Analysis*, Fisheries Research Board of Canada Bulletin 167
172. Timmer A, Hoor T (1974) *Mar Chem* **2**:149
173. David ARJ, MacCormack T, Morris AW, Worsfold PJ (1998) *Anal Chim Acta* **31**:63
174. *Methods for the Examination of Water and Associated Materials – Method D Continuous Flow Methods for the Determination of Total Oxidised Nitrogen or Nitrite in Seawater*, Department of the Environment, National Water Council Standing Committee of Analysts, HMSO, London (1981)
175. Ito K, Ariyoshi Y, Tanabiki F, Sunbara H (1991) *Anal Chem* **63**:273
176. Matthews AD, Riley JP (1970) *Anal Chim Acta* **51**:455
177. Johnson KS, Petty RL (1982) *Anal Chem* **54**:1185
178. Murphy J, Riley JP (1962) *Anal Chim Acta* **27**:31
179. Pakalus P, McAllister BR (1972) *J Mar Res* **30**:305
180. Hosokawa I, Ohshima F (1973) *Water Res* **7**:283
181. Isaeva AB (1969) *Zh Anal Khim* **24**:1854
182. Ducret L, Drouillas M (1959) *Anal Chim Acta* **21**:86
183. Sudakov FP, Klitina VI, Dan'shova T Ya (1966) *Zh Anal Khim* **21**:1333
184. Babko AK, Shkaravskii Yu F, Kulik VI (1966) *Zh Anal Khim* **21**:196
185. Matsuo T, Shida J, Kurihara W (1977) *Anal Chim Acta* **91**:385
186. Kirkbright GS, Narayanaswamy R, West TS (1971) *Anal Chem* **43**:1434
187. Motomizu S, Wakimoto T, Toei K (1982) *Anal Chem* **138**:329
188. Motomizu S, Wakimoto T, Toei K (1984) *Talanta* **31**:235
189. Bajic SJ, Jaselkis B (1985) *Talanta* **32**:115
190. Hydes DK, Hill NC (1985) *Estuar Coast Shelf Sci* **21**:127
191. Flynn WW, Meehan W (1973) *Anal Chim Acta* **63**:483
192. Deans DR (1982) *Anal Chem* **43**:2026
193. Yoshimura K, Ishii M, Tarutani T (1986) *Anal Chem* **58**:591
194. Eberlein K, Kattner G (1987) *Fresen Z Anal Chem* **326**:354
195. Airey D, Dal Pont G, Sanders (1984) *Anal Chim Acta* **166**:79
196. Itoh K, Nakayama M, Chikuma M, Tanaka H (1985) *Fresen Z Anal Chem* **321**:56
197. Wollast R in *The Sea*, Volume 4, Goldberg E (ed) Wiley New York (1974) p. 359
198. Edmund JM, Jacobs SS, Gorden AL (1979) *J Geophys Res* **84**:7809
199. Hargis LG (1970) *Anal Chim Acta* **52**:1
200. Halasz A, Polak K, Pungor E (1971) *Talanta* **18**:691
201. Golkowsa A, Pszonicki L (1973) *Talanta* **20**:749
202. Kreshkov AP, Organesyan LB, Ogareva MB (1976) *J Anal Chem (USSR)* **31**:723
203. Bashikdash'yan MT, Vasil'eva MG (1981) *J Anal Chem (USSR)* **36**:747
204. Riley JP (1975) *Chemical Oceanography* Volume 3, 2nd Edition Riley JP, Skirrow G (ed) Academic Press London p. 193
205. Armstrong FA (1951) *J Mar Biol Assoc* **30**:149
206. Grasshof K (1966) *Z Anal Chem* **220**:89
207. Brewer PJ, Riley JP (1966) *Anal Chim Acta* **35**:514

208. Spencer DW, Brewer PG (1970) *Crit Rev Solid State Sci* 1:410
209. Liss PS, Spencer CP (1969) *J Mar Biol Assoc* 49:589
210. Strickland P, Parsons O (1965) *Bulletin of the Fisheries Research Board, Canada* 125:50
211. Armstrong AJ (1951) *J Mar Biol Assoc* 30:149
212. Grasshof O (1964) *Oceanographic Abstracts* 11:597
213. Thomson J, Johnson KS, Petty RL (1983) *Anal Chem* 55:2378
214. Brzelinski MA, Nelson DM (1986) *Mar Chem* 19:139
215. Hioki A, Law JWH, McLaren JW (1997) *Anal Chem* 69:21
216. Spencer CP in *Chemical Oceanography* Volume 2, 2nd Edition (1975) Riley JP, Skirrow G (eds) Academic Press New York p250-251
217. Sakai H, Fujiwara T, Kumamaru T (1993) *Bull Chem Soc Japan* 66:3401
218. Kanno S, Goto R (1994) *Kogyo Yosui* 433:50
219. Sakai H, Fujiwara T, Kumamaru T (1995) *Anal Chim Acta* 302:173
220. Cutter GA, Oatts TJ (1987) *Anal Chem* 59:717
221. Leck C, Bagander LE (1988) *Anal Chem* 60:1680
222. Fukushi K, Hiiro K (1987) *J Chrom* 393:433
223. Jagner D (1970) *Anal Chim Acta* 52:483
224. Lebel J (1980) *Mar Chem* 9:237
225. Miles DL, Cook JM (1982) *Anal Chim Acta* 141:207
226. Luther GW, Mavarson AL (1975) *Anal Chem* 47:2058
227. Singh RP, Pambid ER, Abbas NM (1991) *Anal Chem* 63:1897
228. Nasu T, Kan M (1988) *Analyst* 113:1683
229. Johnson DL, Pilson EQ (1972) *Anal Chem* 58:289
230. Airey D, Dal Pont G, Sanders G (1984) *Anal Chim Acta* 166:79
231. Hu W, Takeuchi T, Haraguchi H (1993) *Anal Chem* 65:2204
232. Hu W, Haraguchi H (1994) *Anal Chem* 66:765
233. Hu W, Tominaga M, Tao H, Itoh A, Umemura T, Haraguchi H (1995) 67:3713
234. Hu W, Haraguchi H (1996) *J Chrom* 723:251
235. Hu W, Hasebe K, Reynolds DM et al. (1997) *J Liq Chrom Rel Tech* 20:1903
236. Hu W, Haddad PR (1998) *Trends Anal Chem* 17:69
237. Hu W, Hasebe K, Reynolds DM, Haraguchi H (1997) *Anal Chim Acta* 358:143
238. Hu W, Haddad PR (1998) *Anal Comm* 35:317
239. Hu W, Haddad PR, Hasebe K, Tanaka K, Tong P, Khoo C (1999) *Anal Chem* 71:1617
240. Sigman DM, Altabet MA, Michener R et al. (1997) *Mar Chem* 57:227
241. Debaar HJW, Van Leeuwe MA, Scharek R, Goeyens L, Bakker KMJ, Fritsche P (1997) *Deep-Sea Res Part II* 44:229
242. Hutchins DA, Bruland KW (1998) *Nature* 393:561
243. Kirkwood DS, Aminot A, Perttila M (1991) *Fourth Intercomparison Exercise for Nutrients in Sea Water (ICES)* Copenhagen Cooperative Research Report p. 174
244. Aminot A, Kerouel R (1991) *Anal Chim Acta* 248:277
245. Aminot A, Kerouel R (1995) *Mar Chem* 49:221
246. Sedijl M, Lu GN (1998) *Measuring Science* 9:1587
247. Yaakov SB, Ruth E (1974) *Limnol Oceanogr* 19:144
248. Yaakov SB, Ruth E (1969) *Water Pollution Abstract* 42:1757
249. Khoo KH, Ramette W, Culbeeson CH, Bates RG (1977) *Anal Chem* 49:29
250. Willie SN, Sturgeon RE, Berman SS (1983) *Anal Chem* 55:981
251. Miyazaki A, Brancho K (1987) *Anal Chim Acta* 198:297
252. Shriadah HMA, Katoeka M, Ohzebi K (1985) *Analyst* 110:125
253. Kuroda R, Matsumoto M, Ogmura K (1988) *Fresen Z Anal Chem* 330:111

3 Anions in Estuary and Coastal Waters

Very limited work has been published on the determination of anions in estuary and coastal waters. However, there is no doubt that the open seawater analysis methods discussed in Chap. 2 would in many instances be applicable to estuary and coastal waters.

3.1

Nitrate

3.1.1

Ultraviolet Spectroscopy

Brown and Bellinger [1] have proposed an ultraviolet technique which is applicable to both polluted and unpolluted fresh waters and some estuarine waters. Humic acid and other organics are removed on an ion exchange resin. Bromide interference in seawater samples can be minimised by suitable dilution of the sample but this raises the lower limit of detection such that only on relatively rich (0.5 mg/l nitrate) estuarine and inshore waters could the method be applied. Chloride at concentrations in excess of 10 000 mg/l does not interfere.

The method is either not affected by or can allow for interference from phosphate, sulfate, carbonate, bicarbonate, nitrite, coloured metal complexes, ammonia, dyes, detergents, phenols, and other ultraviolet absorbing substances.

The determination of nitrate is also discussed under multianion analysis in Sect. 3.6.1.

3.2

Nitrate and Nitrite

3.2.1

Autoanalyser Method

Petts [2] has described a procedure for the determination of total nitrate plus nitrite in estuary waters ranging in salinity from 2.17 to 33.1 g/kg. In this method oxidised nitrogen in the sample is reduced to nitrite by a cop-

per/cadmium reduction column and reacted with *N*-1-naphthylethylene diaminedihydrochloride under acidic conditions to produce an azo dye which is evaluated spectrophotometrically at 550 nm. The range of application of the method is 1 – 800 μg nitrogen. Standard deviations range from 4.2 μg N/l at the 14 μg N/l level to 2.8 μg N/l at the 70 μg N/l level.

3.3

Phosphate

3.3.1

Spectrophotometric Method

A commonly used procedure for the determination of phosphate in seawater and estuarine waters involves the formation of the molybdenum blue complex at 35–40 °C in an autoanalyser, and spectrophotometric evaluation of the colour produced [3]. Unfortunately, when applied to seawater samples, depending on the chloride content of the sample, peak distortion or even negative peaks occur which make it impossible to obtain reliable phosphate values. This effect can be overcome by the replacement of the distilled water used in such methods by a solution of sodium chloride of appropriate concentration related to the chloride concentration of the sample. The chloride content of the wash solution need not be exactly equal to that of the sample. For chloride contents in a sample up to 18 000 mg/l, (i.e., seawater), the chloride concentration in the wash should be within $\pm 15\%$ of that in the sample. The use of saline standards is optional but the use of saline control solutions is mandatory. Using good equipment, down to 0.02 mg/l phosphate can be determined by such procedures. For chloride contents above 18 000 mg/l, the chloride content of the wash should be within $\pm 5\%$ of that in the sample. See also Sect. 3.6.1.

3.4

Selenate and Selenite

3.4.1

Spectrofluorometric Method

Itoh et al. [4] determined selenium(IV) in estuarine waters by an anion exchange resin modified with bismuthiol(II) and diamminonaphthalene. An Amberlite IRA-400 anion exchange resin was modified by mixing with an aqueous solution of bismuthiol(II) to give 0.2 mmol bismuthiol per g of resin. Sample solution was eluted through a column packed with the modified resin. Selenium(IV) adsorbed as selenotrisulfate was then eluted from the column with either 0.1 mol/l penicillamine or 0.1 mol/l cysteine. The eluate was then subjected to an acid digestion procedure to reduce selenium to the tetravalent

state with diamionaphthalene for fluorometric determination. Approximate agreement with the tellurium coprecipitation method was obtained. The application of both methods to the analysis of estuarine waters permitted the separate determination of both selenium(IV) and selenium(VI), since the tellurium coprecipitation method did not differentiate between the two species.

3.4.2

Atomic Absorption Spectrometry

Most cations and anions cause interference on the atomisation of selenium. Bismuth and antimony depress selenium adsorption.

Arsenic lowered somewhat the peak temperature in atomisation profile for selenium. Copper tends to suppress the interferences of diverse elements on atomisation of selenium. However, the interferences from large concentrations of diverse elements and matrices were not improved even in the presence of copper at the atomisation step. Therefore, the separation of selenium from matrices was recommended.

Selenium is extracted as diethyldithiocarbamate complex from the solution containing citrate and EDTA [5]. Ohta and Suzuki [6] found that only a few elements, such as copper, bismuth, arsenic, antimony, and tellurium, are also extracted together with selenium. They examined this for effects of hundredfold amounts of elements co-extracted with the selenium diethyldithiocarbamate complex. An appreciable improvement of interferences from diverse elements was observed in the presence of copper. Silver depressed the selenium absorption in the case of atomisation of diethyldithiocarbamate complex, but the interference of silver was suppressed in the presence of copper. The atomisation profile from diethyldithiocarbamate complex was identical with that from selenide.

No selenium(VI) is extractable from citrate buffered solution containing EDTA and copper. Therefore, tetra- and hexavalent selenium could be determined separately.

The recovery of selenium was satisfactory. The forms of selenium in waters are known to be selenite and selenate [7]. Selenium occurs in non-saline water at concentrations ranging from less than 0.0002 $\mu\text{g/l}$ to greater than 50 $\mu\text{g/l}$. Therefore, a large sample size is necessary for analysis at lower concentration levels.

3.5

Sulfate

3.5.1

Spectrophotometric Method

The determination of sulfate is discussed under multianion analysis in Sect. 3.6.1.

3.6

Multianion Analysis

3.6.1

Spectrophotometric Method, Sulfate, Phosphate, Nitrate, and Sulfide

Airey et al. [8] have described a method for removing sulfide prior to the determination of these anions in anoxic estuarine waters. Mercury(II) chloride was used to precipitate free sulfide from samples of anoxic water. The sulfide-free supernatant solution was used to estimate sulfide by measuring the concentration of unreacted mercury(II), as well as to determine sulfate, inorganic phosphate, and nitrate by spectrophotometric methods, in which sulfide interferes. Sulfide concentrations in the range 0.5–180 000 $\mu\text{g/l}$ sulfur could be measured, while the lower limits for sulfate, ammonia, nitrite, and inorganic phosphate were 0.024, –1.0 and 1 $\mu\text{g/l}$, respectively.

References

1. Brown L, Bellinger EL (1978) *Water Res* **223**, 12
2. Petts KW (1979) *The determination of oxidised nitrogen and nitrite in estuarine waters by autoanalysis*, Technical Report TR 120. Water Research Centre, Medmenham Laboratory, UK
3. Crompton TR, Unpublished work
4. Itoh K, Nakayama M, Chikuma M, Tanaka H (1985) *Fresen Z Anal Chem* **321**:56
5. Bode H (1954) *Fresen Z Anal Chem* **143**:182
6. Ohta K, Suzuki M (1980) *Fresen Z Anal Chem* **302**:177
7. Cheam V, Agemian H (1980) *Anal Chim Acta* **113**:237
8. Airey D, Dal Pont G, Sanders G (1984) *Anal Chim Acta* **106**:79

4 Dissolved Gases

Spencer and Brewer [1] have reviewed methods for the determination of dissolved gases in seawater (O_2 , CO_2 , N_2 , H_2S , inert gases).

4.1

Free Chlorine

4.1.1

Amperometric Titration Procedures

Although the amperometric titrimetric method has been accepted as a standard method for the determination of total residual chlorine in chlorinated effluents [2], recent reports [3,4] have suggested that in the case of chlorinated waters, significant errors may occur if certain precautions are not taken. Furthermore, somewhat opposing views were presented in these reports on what the optimal procedure might be.

When molecular chlorine or hypochlorous acid is added to seawater, the following rapid reactions (reactions (4.1) and (4.2)) ensue and hypobromite is formed [5]:



There is enough bromide in seawater at 35‰ salinity to convert 60 mg/l of chlorine to hypobromite.

In the amperometric titration for the determination of total residual chlorine in seawater, tri-iodide ions are generated by the reaction between hypochlorite and/or hypobromite with excess iodide pH 4 (reactions (4.3) and (4.4)). The pH is buffered by adding a pH 4 acetic acid–sodium acetate buffer to the sample.

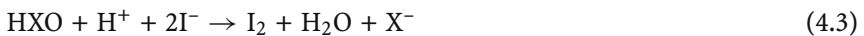

where X may be Cl or Br. The tri-iodide ion is then titrated with phenylarsine oxide (reaction (4.5)) and the end-point is determined amperometrically.



Carpenter et al. [3] suggest that this method may have underestimated the true value by a factor of three or more. The error was proposed to be due to the oxidation of iodide to iodate by molecular bromine and/or hypobromous acid (reaction (4.6)),



and iodate does not revert directly with phenylarsine oxide. Furthermore, at pH 4, the reaction between iodate and excess iodide to form tri-iodide ion (reaction (4.7)) is sluggish:



Thus an apparent loss in total residual chlorine may be observed.

Carpenter et al. [3] proposed that, in order to overcome this difficulty, higher acidity and higher potassium iodide concentrations or a back titration procedure should be used.

Goldman et al. [4], on the other hand, suggest that the order of the addition of the reagents for generating tri-iodide ions is crucial for obtaining accurate results. If the acidic buffer is added first, at pH 4, molecular bromine may be formed (reaction (4.8)):



and its loss by volatilisation may cause an apparent loss in total residual chlorine. Thus they recommended that potassium iodide should be added before the acidic buffer solution. When potassium iodide is added to the chlorinated solution, hypoiodite will be formed (reaction (4.9)).



The disproportionation of hypoiodite to form iodate (reaction (4.10)) is believed to be slow in slightly alkaline solutions such as seawater [6, 7].



Upon subsequent acidification at pH 4, hypoiodite is converted to molecular iodine (reaction (4.11))



which is, in turn, converted to tri-iodide ion (reaction (4.4)). Since tri-iodide is a heavy ion, its loss by volatilization will be negligible if the titration follows the addition of the reagents promptly. The accepted standard procedure [2] calls for the addition of potassium iodide before the acidic buffer solution. However, this point is not stressed, and its importance is never discussed. Goldman et al. [4] further reported that the backward titration procedure does not significantly increase the total residual chlorine concentration.

Since reaction (4.6) is favoured in basic solutions, if Carpenter et al. [3] are correct, the longer molecular bromine and/or hypobromous acid are allowed

to react with iodide at the natural pH 8 of seawater, the greater the amount of iodate that will be formed. Consequently, there will be a greater apparent loss of total residual chlorine. This would imply that adding the acidic buffer prior to the addition of potassium iodide may minimise the source of error, because in an acidic solution reaction (4.6) will be forced to the left. On the other hand if acid is added first, the apparent loss of total residual chlorine should increase with faster stirring rate and with longer time for stirring between the addition of the two reagents. The apparently contradictory implications for these two hypotheses were tested by Wong [8].

Wong [8] found that the determination of residual chlorine in seawater by the amperometric titrimetric method, potassium iodide must be added to the sample before the addition of the pH 4 buffer, and the addition of these two reagents should not be more than a minute apart. Serious analytical error may arise if the order of addition of the reagents is reversed. There is no evidence suggesting the formation of iodate by the reaction between hypobromite and iodide. Concentrations of residual chlorine below 1 mg/l iodate, which occurs naturally in seawater, causes serious analytical uncertainties.

In the sodium borate solution containing bromide, when the pH 4 buffer is added before the potassium iodate solution, titrations give low total residual chlorine concentrations. This loss increases with the amount of stirring time between the addition of the reagents. Even for a stirring time of 10 seconds, there is a loss of about 17% of the total residual chlorine. If the solution were stirred for 30 min, 85% of the chlorine would have disappeared. The concentration of total residual chlorine determined by the reference methods does not change throughout the experiment. This implies that this loss of chlorine does not occur in the reaction vessel, but in the titration cell as a result of the analytical procedure.

If potassium iodide is added first, and then the solution is stirred, acidified and titrated, the loss of residual chlorine is reduced, although still significant. The loss again increases monotonically with stirring for 20 min. However, for a stirring time of 1 minute or less, the loss is not detectable within the uncertainty of the analytical method. There is a loss of chlorine whether the sample is stirred in the titrator or on a stirrer, although the loss seems smaller in the latter case. For a stirring time of 20 min, only 24% of the residual chlorine is lost. Moreover, titrations performed at pH 2 and pH 4 yield the same residual chlorine concentrations.

Wong [8] reported that the losses of chlorine are not related to the formation of iodate by the oxidation of iodide by hypobromite. The presence of iodate in seawater may cause significant uncertainty in the determination of small quantities of residual chlorine in water. Determinations of residual chlorine at the 0.01 mg/l level are of questionable significance.

Carpenter and Smith [9] and Wong [8] pointed out that iodate is also a natural constituent of seawater. Thus it may cause a variable positive blank

of up to 0.1 mg/l (1.4 $\mu\text{equiv/l}$) residual chlorine. This source of error may be safely neglected only for concentrations above 2 mg/l (28 $\mu\text{equiv/l}$). Carpenter and Smith proposed that iodate may be converted completely to tri-iodide by using a lower pH or larger excess of iodide in the titration. However, other side reactions such as the oxidation of iodide by nitrite may interfere with the analysis under these modified conditions. As this presumably standard method is being applied to samples with lower and lower concentrations, interferences and blanks previously considered minor may become significant.

Wong [10, 11] has studied this in further detail and found that carrying out the titration at pH 2 yields a true concentration of total residual chlorine after correction for naturally occurring iodate. The effectiveness of sulfamic acid in this method for removal of the nitrite interference is shown in Fig. 4.1. In this experiment, all the solutions contained 30 $\mu\text{mol/l}$ nitrite, and about 0.5 $\mu\text{mol/l}$ of iodate. The absorbance of the solution at 353 nm decreased with increasing amounts of added sulphamic acid. A constant absorbance was recorded when 3 ml or more of 1% (*w/v*) sulphamic acid was added to the solution, and this absorbance was identical with that in a sample containing the same amount of iodate and no nitrite. A concentration of nitrite of 30 $\mu\text{mol/l}$ is unlikely to occur in estuarine water and seawater:

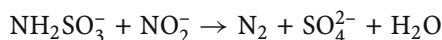

Carlson and Weberg [12] have also studied the interference from iodate during the iodometric determination of residual chlorine in seawater. These workers confirmed that due to the presence of naturally occurring iodate, results from the iodometric determination carried out at pH 2 were up to 20% higher

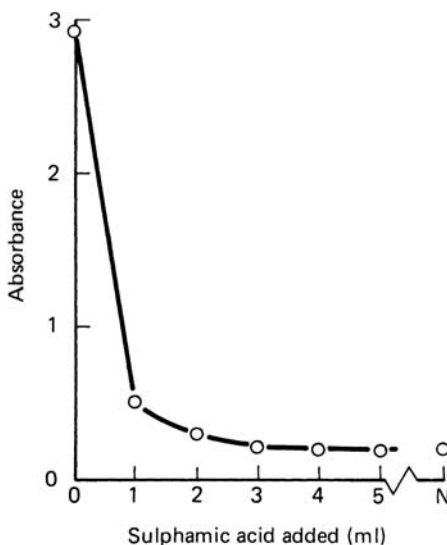
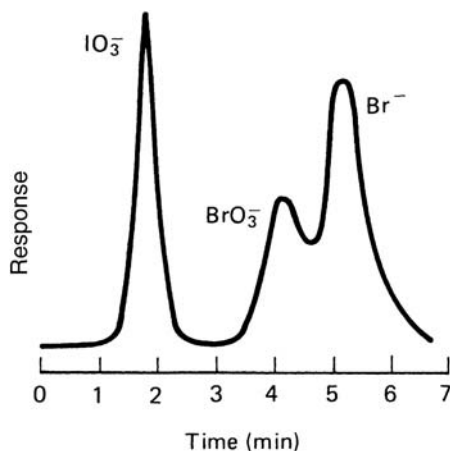

Figure 4.1. Absorbance of tri-iodide at 353 nm formed from a fixed concentration of iodate in the presence of 30 $\mu\text{mol/l}$ nitrite upon the addition of various volumes of 1% (*w/v*) sulphamic acid; N denotes the case where neither nitrite nor sulphamic acid was present in the solution. From [8]

Figure 4.2. Determination of iodate, bromate, and bromide. From [12]



than those obtained in determinations carried out at pH 4. These workers seem to have been unaware of the results obtained by Wong as discussed above.

Carlson and Weberg [12] used mobile phase ion-chromatography to separate iodate, bromate, bromide, and iodide (Fig. 4.2). Ion-chromatography of a mixture of iodide and bromide which had been treated with hypochlorite clearly showed the presence of iodate and the absence of bromate. These results demonstrated that iodate generates iodine from iodide very quickly at pH 2 ($\text{IO}_3^- + 5\text{I}^- + 6\text{H}^+ \rightarrow 3\text{I}_2 + 3\text{H}_2\text{O}$) and relatively slowly at pH 4; while bromate fails to react with iodide at pH 4 and does so slowly at pH 2 ($\text{BrO}_3^- + 6\text{I}^- + 6\text{H}^+ = \text{Br}^- + 3\text{I}_2 + 3\text{H}_2\text{O}$). Moreover, chromatographic analysis (C_{18} column) of an iodate solution (10^{-4} M) after iodide addition (24 min pH 4) confirmed the continued presence of iodate. The concentration of iodate after this period (40% of original) agrees with the corresponding titration results.

The practical application of these observations is to minimise the effect of iodate by rapidly carrying out the iodometric titration of chlorine residual in seawater at pH 4. Moreover, if desired, a titration correction curve can be generated using iodate at the specific concentration of iodide in the sample in question, as there appears to be a complete conversion of seawater iodide to iodate in the presence of excess chlorine.

Other methods for the determination of chlorine in seawater or saline waters are based on the use of barbituric acid [13] and on the use of residual chlorine electrodes [14] or amperometric membrane probes [15, 16]. In the barbituric acid method [12], chlorine reacts rapidly in the presence of bromide and has completely disappeared after 1 minute. This result, which was verified in the range pH 7.5–9.4, proves the absence of free chlorine in seawater. A study of the colorimetric deterioration of free halogens by the diethylparaphenylenediamine technique shows that the titration curve of the compound obtained is more like the bromine curve than that of chlorine. The author suggests

drawing a calibration curve for different concentrations of chlorine in solution containing 60 mg/l of bromide.

The work carried out by Dimmock and Midgley [14–16] at the Central Electricity Board, UK is concerned with the analysis of cooling waters, saline and non-saline. Although the analysis of seawater is not specifically discussed, their work may be of some relevance.

4.2

Ozone

Sheeter [17] has discussed an ultraviolet method for the measurement of ozone in seawater. Crecelius [18] has discussed oxidation products obtained (bromine, hypobromous acid, bromate) when bromides in seawater are oxidised by ozone.

4.3

Nitric Oxide

Cohen [19] used electron capture gas chromatography to determine traces of dissolved nitric oxide in seawater. Precision and accuracy are, respectively, 2% and 3%.

4.4

Hydrogen Sulfide

Flow injection analysis has been used for the automated determination of hydrogen sulfide in seawater [20]. A low-sensitivity flow injection analysis manifold for concentrations up to 200 $\mu\text{mol/l}$ hydrogen sulfide had a detection limit of 0.12 $\mu\text{mol/l}$. Sulfide standards were calibrated by colorimetric measurement of the excess tri-iodide ion remaining after reaction of sulfide with iodine. The coefficient of variation was less than 1% at concentrations greater than 10 $\mu\text{mol/l}$. The method was fast, accurate, sensitive enough for most natural waters, and could be used both for discrete and continuous analysis.

4.5

Carbon Dioxide

Murphy et al. [21] have described an infrared based detector method for the determination of carbon dioxide in seawater.

Neill et al. [22] have described a headspace gas chromatographic method for the determination of carbon dioxide (fugacity) in seawater. This method requires a small water sample (60 ml), and provides for rapid analysis (2 min).

Lehaitre et al. [23] have described a fibre-optic spectrophotometric method for the in situ measurement of biological and chemical species. This instrument can measure phytoplanktonic species, and the potential for chemical measurement such as dissolved carbon dioxide is analysed.

Fukushi and Hiroyuki et al. [24] described a method for determining total carbon dioxide in seawater by capillary isotachoelectrophoresis following isolation of the carbon dioxide by membrane permeation.

Tabacco et al. [25] have described a method based on emission spectrometry at an excitation wavelength of 488 nm for the telemetric measurements of carbon dioxide tensions in seawater.

Yong Suk Choi et al. [26] used a carbonate-selective electrode to determine dissolved carbon dioxide in the oceans.

References

1. Spencer DW, Brewer PC (1970) *Crit Rev Solid State Sci* 1:409
2. *Standard Methods for the Examination of Water and Waste Water* Rand MC, Greenberg AE, Taras MJ (eds) 14th Edn (1976) American Public Health Association Washington, DC
3. Carpenter JH, Moore CA, Macalady DL (1977) *Environ Sci Technol* 11:992
4. Goldman JC, Quinby HL, Capuzzo JM (1979) *Water Res* 13:315
5. Wong GTF, Davidson JA (1977) *Water Res* 11:971
6. Li CH, White CF (1943) *J Am Chem Soc* 65:335
7. Truesdale VW (1974) *Deep-Sea Res* 21:761
8. Wong GTF (1980) *Water Res* 14:51
9. Carpenter JH, Smith CA in *Water Chlorination - Environmental Impact and Health Effects* Jolley RL, Gorchev H, and Hamilton DH (eds) Volume 2 (1978) Ann Arbor Science, Ann Arbor, MI, p. 195-208
10. Wong GTF (1982) *Environ Sci Technol* 16:785
11. Wong GTF (1977) *Deep-Sea Res* 24:115
12. Carlson RF, Weberg RT (1977) *Chemosphere* 12:125
13. Figuet JM (1978) *Techniques et Sciences Municipales* 73:239
14. Dimmock NA, Ridgeley D (1982) *Talanta* 29:557
15. Dimmock NA, Ridgeley D (1979) *Water Res* 13:1101
16. Dimmock NA, Ridgeley D (1979) *Water Res* 13:1317
17. Sheeter H (1973) *Water Res* 7:729
18. Creelius EA (1979) *Journal of the Fisheries Research Board Canada* 36:1006
19. Cohen Y (1977) *Anal Chem* 49:1238
20. Sakamoto O, Arnold CM, Johnson VS, Beehler CL (1986) *Limnol Oceanogr* 31:894
21. Murphy PP, Feely RA, Wanninkhof R (1998) *Mar Chem* 62:103
22. Neill C, Johnson KM, Lewis E, Wallace DWR (1997) *Limnol Oceanogr* 42:1774
23. Lehaitre M, Le Bris M, Ouisse A, Belinger A (1997) *J Mar Environ Eng* 4:85
24. Fukushi F, Hiro K (1987) *Fresen J Anal Chem* 328:247
25. Tabacco MB, Uttamiat M, Mc Allister M, Walt DR (1999) *Anal Chem* 71:154 and a correction in (1999) *Anal Chem* 71:1483
26. Choi YS, Lvova L, Shin JH, Oh SH, Lee CS, Kim BH, Cha GS, Nam H (2002) *Anal Chem* 74:2435

5 Cations in Seawater

5.1

Introduction

Determination of trace metals in seawater represents one of the most challenging tasks in chemical analysis because the parts per billion (ppb) or sub-ppb levels of analyte are very susceptible to matrix interference from alkali or alkaline-earth metals and their associated counterions. For instance, the alkali metals tend to affect the atomisation and the ionisation equilibrium process in atomic spectroscopy, and the associated counterions such as the chloride ions might be preferentially adsorbed onto the electrode surface to give some undesirable electrochemical side reactions in voltammetric analysis. Thus, most current methods for seawater analysis employ some kind of analyte preconcentration along with matrix rejection techniques. These preconcentration techniques include coprecipitation, solvent extraction, column adsorption, electrodeposition, and Donnan dialysis.

Measurement techniques that can be employed for the determination of trace metals include atomic absorption spectrometry, anodic stripping voltammetry, differential pulse cathodic stripping voltammetry, inductively coupled plasma atomic emission spectrometry, liquid chromatography of the metal chelates with ultraviolet-visible absorption and, more recently, inductively coupled plasma mass spectrometry.

Many of the published methods for the determination of metals in seawater are concerned with the determination of a single element. Single-element methods are discussed firstly in Sects. 5.2–5.73. However, much of the published work is concerned not only with the determination of a single element but with the determination of groups of elements (Sect. 5.74). This is particularly so in the case of techniques such as graphite furnace atomic absorption spectrometry, Zeeman background-corrected atomic absorption spectrometry, and inductively coupled plasma spectrometry. This also applies to other techniques, such as voltammetry, polarography, neutron activation analysis, X-ray fluorescence spectroscopy, and isotope dilution techniques.

The background concentrations at which metals occur in seawater are extremely low, and much work has been done on preconcentration procedures in attempts to improve detection limits for these metals. Various preconcentra-

tion techniques, including hydride generation used before atomic absorption spectrometry, are discussed.

Methods for determining metals in seawater have been published by the Standing Committee of Analysts (i.e., the blue book series, HMSO, London); they are not reproduced in this book, as they are available elsewhere. These methods are based on chelation of the metals with an organic reagent, followed by atomic absorption spectroscopy.

Pelizzetti [496] has reviewed the analysed seawater, including particles, colloids, and trace elements, along with their speciation (66 references).

5.2

Actinium

Lin [1] used coprecipitation with lead sulfate to separate $^{237}\text{actinium}$ from sea water samples. The $^{237}\text{actinium}$ was purified by extraction with HDEHP, and determined by alpha spectrometry via Si (Au) surface barrier detection. The method has a sensitivity of $10^{-3} \text{ pCi g}^{-1}$ of ashed sample.

5.3

Aluminium

5.3.1

Spectrophotometric Methods

Aluminium has been determined by spectrophotometric methods using aluminon [2,3], oxine [4,5], Eriochrome Cyanine R [6] and Chrome Azurol S [7], fluorometric methods using Pontachrome Blue Black R [8,9], Lumogallion [9–12] and salicylaldehyde semicarbazone [13–17], gas chromatographic methods [18, 19], emission spectroscopy [20], and neutron activation analysis [21, 22]. Most of these methods necessitate pretreatment steps and special and expensive instruments, require large volumes of sample solution, and are time-consuming. For instance, although the fluorometric method using Lumogallion reported by Hydes and Liss [12] is sensitive and rapid, the fluorescence spectrophotometer used is not as popular an instrument as the spectrophotometer. Dougan and Wilson [23] have also reported the spectrophotometric determination of aluminium (at concentrations of 0.05 and 0.3 mg/l) in water with pyrocatechol violet, and Henriksen and coworkers [24, 25] have improved the method to some extent, but these procedures are not satisfactory for the concentrations of aluminium normally found in seawater (about 2 $\mu\text{g/l}$).

Korenaga et al. [26] have described an extraction procedure for the spectrophotometric determination of trace amounts of aluminium in seawater with pyrocatechol violet. The extraction of ion-associate between the aluminium/pyrocatechol violet complex and the quaternary ammonium salt,

zephiramine (tetradecyldimethylbenzyl ammonium chloride), is carried out with 100 ml seawater and 10 ml chloroform. The excess of reagent extracted is removed by back-washing with 0.25 M sodium bromide solution at pH 9.5.

The calibration graph at 590 nm obeyed Beer's law over the range 0.13–1.34 μg aluminium. The apparent molar absorptivity in chloroform was $9.8 \times 10^4 \text{ l mol}^{-1} \text{ cm}^{-1}$.

Several ions (e.g., manganese, iron (II), iron (III), cobalt, nickel, copper, zinc, cadmium, lead, and uranyl) react with pyrocatechol violet, and to some extent are extracted together with aluminium. The interferences from these ions and other metal ions generally present in seawater could be eliminated by extraction with diethyldithiocarbamate as masking agent. With this agent most of the metal ions except aluminium were extracted into chloroform, and other metal ions did not react in the amounts commonly found in seawater. Levels of aluminium between 6 and 6.3 $\mu\text{g/l}$ were found in Pacific Ocean and Japan Sea samples by this method.

5.3.2

Spectrofluorometric Methods

Howard [27] determined dissolved aluminium in seawater by the micelle-enhanced fluorescence of its lumogallion complex. Several surfactants (to enhance fluorescence and minimise interferences), used for the determination of aluminium at very low concentrations (below 0.5 $\mu\text{g/l}$) in seawaters, were compared. The surfactants tested in preliminary studies were anionic (sodium lauryl sulfate), non-ionic (Triton X-100, Nonidet P42, NOPCO, and Tergital XD), and cationic (cetyltrimethylammonium bromide). Based on the degree of fluorescence enhancement and ease of use, Triton X-100 was selected for further study. Sample solutions (25 ml) in polyethylene bottles were mixed with acetate buffer (pH 4.7, 2 ml) lumogallion solution (0.02%, 0.3 ml) and 1,10-phenanthroline (1.0 ml to mask interferences from iron). Samples were heated to 80 °C for 1.5 h, cooled, and shaken with neat surfactant (0.15 ml) before fluorescence measurements were made. This procedure had a detection limit at the 0.02 $\mu\text{g/l}$ level. The method was independent of salinity and could therefore be used for both freshwater and seawater samples.

Salgado Ordonez et al. [28] used di-2-pyridylketone 2-furoyl-hydrazone as a reagent for the fluorometric determination of down to 0.2 μg aluminium in seawater. A buffer solution at pH 6.3, and 1 ml of the reagent solution were added to the samples containing between 0.25 to 2.50 μg aluminium. Fluorescence was measured at 465 nm, and the aluminium in the sample determined either from a calibration graph prepared under the same conditions or a standard addition procedure. Aluminium could be determined in the 10–100 $\mu\text{g/l}$ range. The method was satisfactorily applied to spiked and natural seawater samples.

5.3.3

Atomic Absorption Spectrometry

Spencer and Sachs [29] determined particulate aluminium in seawater by atomic absorption spectrometry. The suspended matter was collected from seawater (at least 2 litres) on a 0.45 μm membrane filter, the filter was ashed, and the residue was heated to fumes with 2 ml concentrated hydrofluoric acid and one drop of concentrated sulfuric acid. This residue was dissolved in 2 ml 2 M hydrochloric acid and the solution was diluted to give an aluminium concentration in the range 5–50 $\mu\text{g/l}$. Atomic absorption determination was carried out with a nitrous oxide acetylene flame. The effects of calcium, iron, sodium, and sulfate alone and in combination on the aluminium absorption were studied.

5.3.4

Anodic Stripping Voltammetry

Van den Berg et al. [30] determined aluminium in seawater by anodic stripping voltammetry. They give details of a procedure for the determination of dissolved aluminium in natural waters, including seawater, by complexation with 1,2-dihydroxyanthraquinone-3-sulfonic acid, collection of the complex on a hanging mercury drop electrode, and determination by cathodic stripping voltammetry. The advantages of this method over other techniques are indicated and optimal conditions are described. The total time required was 10–15 min per sample and the limit of detection was 1 nmol/l aluminium for an adsorption time of 45 s. No serious interferences were found, but ultraviolet irradiation was recommended for samples with high organic content.

5.3.5

Gas Chromatography

An example of a gas chromatographic method is that of Lee and Burrell [18]. In this method the aluminium is extracted by shaking a 30 ml sample (previously subjected to UV radiation to destroy organic matter) with 0.1 M trifluoroacetylacetone in toluene for 1 h. Free reagent is removed from the separated toluene phase by washing it with 0.01 M aqueous ammonia. The toluene phase is injected directly onto a glass column (15 cm \times 6 mm) packed with 4.6% of DC710 and 0.2% Carbowax 20 M on Gas-Chrom Z. The column is operated at 118 $^{\circ}\text{C}$ with nitrogen as carrier gas (285 ml/min) and electron capture detection. Excellent results were obtained from 2 μl of extract containing 6 pg of aluminium. See also Sects. 5.74.9 and 5.74.17.

5.4 Ammonium

5.4.1 Spectrophotometric Methods

Various workers have discussed indophenol methods for the determination of ammonium in seawater [31–46].

Haywood and Huyser's [43] study of the indophenol blue reaction for ammonia determination showed the effect of pH variation on the final colour and emphasised the necessity for the efficient buffering to obtain reproducible results. The optimum conditions found by the authors (pH 10.8 and using sodium nitroprusside) were similar to those used by Solorzano [37]. Haywood and Huyser also replaced acetone with sodium nitroprusside.

Berg and Addullah [47] have described a spectrophotometric autoanalyser method based on phenol, sodium hypochlorite, and sodium nitroprusside for the determination of ammonia in sea and estuarine water (i.e., the indophenol blue method).

The manifold design allows for the determination of ammonia concentration in the range 0.2–20 $\mu\text{g/l}$ as NH_4 over a salinity range 35–10‰, with negligible interference from amino acids.

The interference from amino acids was investigated and found to be negligible as reported by Solorzano [37] and Haywood and Huyser [43], who employed no heating for the indophenol blue colour development. Solutions containing 50 $\mu\text{g N/l}$ of urea, histidine, lycine, glycine, and alanine were analysed. The $\text{NH}_4\text{-N}$ detected ranged between 0.4% (for urea) and 2.2% (for alanine) of the nitrogen added.

Hampson [56] used ferrocyanide catalyst and ultraviolet photon activation energy of appropriate frequency to activate selectively the reaction between ammonia, phenol, and sodium hypochlorite. The reaction is carried out at an optimum pH of 10.5, since urea may break down at a pH over 11 and at a low temperature of $30 \pm 1^\circ\text{C}$. This avoids alkaline hydrolysis of amino acids to ammonia, a process known to occur extensively at higher temperatures. All conditions, including photon flux and ionic activities, are precisely controlled to give stability when indophenol blue type methods such as those of Koroleff and Solarzano [36, 37] have been applied to certain types of samples. Hampson [56] investigated the causes of such colour suppression (Fig. 5.1). Very strong suppression is noted, even at low amine concentrations, and even with indophenol blue formation from the reagent blank suppressed at amine concentrations above 25 ppm N. Numerical analysis of the type of relationship between amine concentration and indophenol blue response to ammonia suggests a third- or possibly fourth-power polynomial function (as distinct from a simple power or exponential relationship).

Figure 5.1. Suppression of indophenol blue response to ammonia by dimethylamine in seawater; 0.4 ppm ammonia N in seawater. From [56]

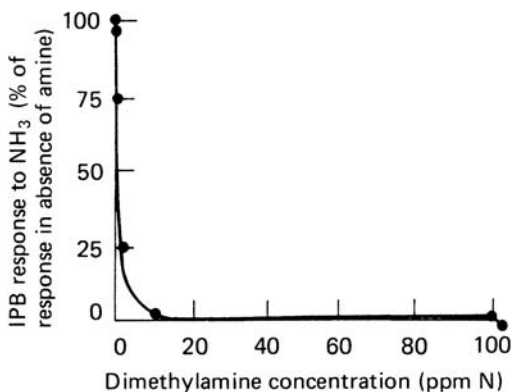

None of these amines gave any indophenol blue response when pure seawater (ammonia free) to which they had been added was subjected to the standard analytical procedure.

To overcome the suppression effect of amines in the determination of ammonia, Hampson [56] investigated the effect of nitrite ions added either as nitrite or as nitrous acid. Figure 5.2 indicates that very considerable suppression by nitrite does occur, although it is not as strong as with any of the amines. Again, it is not great so long as the nitrite N concentration is less than the ammonia N concentration, but rapidly increases as the nitrite concentration exceeds the ammonia concentration. In fact, the nitrite modified method was found to be satisfactory in open seawater samples and polluted estuary waters.

The determination of ammonia in non-saline waters does not present any analytical problems and, as seen above, reliable methods are now available for the determination of ammonia in seawaters. In the case of estuarine waters, however, new problems present themselves. This is because the chloride content of such waters can vary over a wide range from almost nil in rivers entering the estuary to about 18 g/l in the edges of the estuary where the water is virtually pure seawater.

Particularly in autoanalyser methods this wide variation in chloride content of the sample can lead to serious "salt errors" and, indeed, in the extreme case, can lead to negative peaks in samples that are known to contain ammonia. Salt errors originate because of the changes of pH, ionic strength and optical properties with salinity. This phenomenon is not limited to ammonia determination by autoanalyser methods; it has, as will be discussed later, also been observed in the automated determination of phosphate in estuarine samples by molybdenum blue methods.

In a typical survey carried out in an estuary, the analyst may be presented with several hundred samples with a wide range of chloride contents. Before starting any analysis, it is good practice to obtain the electrical conductivity data for such samples so that they can be grouped into increasing ranges of conductivity and each group analysed under the most appropriate conditions.

Figure 5.2. Suppression of indophenol blue response to ammonia by nitrite ion in seawater; 0.4 ppm ammonia N in seawater. Source: [56]

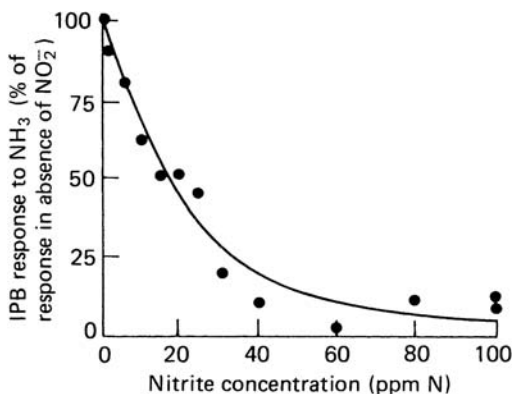

Brezinski [48] has described a spectrophotometric method for the determination of nanomolar concentrations of ammonium in seawater. To seawater samples (180 ml) was added a sequence of reagent solutions in deionised distilled water as follows: phenol (2.4 ml, 10%), sodium aquopentacyanoferrate (1 ml of a freshly prepared solution containing 0.03 g sodium aquopentacyanoferrate in 10⁴ ml of double distilled water) and sodium hypochlorite (6 ml, 5.5%). The sodium aquopentacyanoferrate acted as a coupling reagent in the formation of indophenol. Reaction mixtures were kept in the dark for 2 h at 40 °C and allowed to cool for 1.5 hours before adding phosphoric acid (1 M; 1.65 ml) and *n*-hexane (6.6 ml). The organic phase containing indophenol was pipetted into a clean tube and methylene chloride (10 ml) added followed by pH 12 buffer (10 ml). Indophenol blue was re-extracted into the aqueous phase and its concentration determined colorimetrically at 640 nm. Interference effects by metals, nitrite, urea, and amino acids presents in seawater are discussed. Calibration curves were linear to 2 μM ammonium.

Le Corre and Treguer [49] developed an automated procedure based on oxidation of the ammonium ion by hypochlorite in the presence of sodium bromide followed by spectrophotometric determination of the nitrite. The standard deviation on a set of samples containing 1 μg NH₄⁻-N per litre was 0.02. This method was compared with an automated method for the determination of ammonia as indophenol blue. The results from the two methods are in good agreement.

Urea and amino acids interfere in this procedure. Le Corre and Treguer [49] discuss the effect of salinity on the determination of ammonia and describe a suitable correction procedure.

Other workers who have investigated automated methods for the determination of ammonia in seawater include Grasshoff and Johnnsen [50], Berg and Abdullah [47], Truesdale [51], Matsumaga and Nishimura [46].

Selmer and Sorenson [52] have described a procedure for extraction of ammonium from seawater for ¹⁵N determinations. In this method ammonium nitrogen was converted to indophenol and concentrated onto an octadecylsi-

lane column. Subsequent analysis of the indophenol was that for whole cell material and the atom% of ^{15}N was determined by emission spectrometry. The method was accurate and precise when coupled with other reported methods. The application of the method to field experiments on the west coast of Sweden is described.

5.4.2

Flow Injection Analysis

Willason and Johnson [53] have described a modified flow-injection analysis procedure for ammonia in seawater. Ammonium ions in the sample were converted to ammonia which diffused across a hydrophobic membrane and reacted with an acid-based indicator. Change in light transmittance of the acceptor stream produced by the ammonia was measured by a light emitting diode photometer. The automated method had a detection limit of $0.05\ \mu\text{mol/l}$ and a sampling rate of 60 or more measurement per hour.

5.4.3

Ion-Selective Electrodes

McLean et al. [54] have applied polarography to the determination of ammonia and other nitrogen compounds in brine samples, and Gilbert and Clay [55] have investigated the determination of ammonia in seawater using the ammonia electrode. These latter workers showed that down to 0.01 ppm ammonia can be determined using an electrode (Orion model 95-10) incorporating a hydrophobic membrane that separates the sample solution (adjusted to pH 11 with sodium hydroxide) from an internal solution 0.1 M in ammonium chloride. A glass pH electrode and a Ag-AgCl reference electrode are immersed in the aqueous ammonium chloride. The ammonia in the sample passes through the membrane and the change in pH in the internal solution is detected by the glass electrode. The behaviour and characteristics of the system, including theoretical limits, are discussed.

5.4.4

High-Performance Liquid Chromatography

Gardner et al. [57, 58] have applied this technique to the determination of ammonium ion in seawater. The liquid chromatography method involved fluorometric detection, after post column labelling with *o*-phthalaldehyde/2-mercaptoethanol reagent. This method was developed to directly quantify $^{15}\text{NH}_4$ [$^{14}\text{NH}_4 + ^{15}\text{NH}_4$] ion ratios in aqueous samples that had been enriched with $^{15}\text{NH}_4$ for isotope dilution experiments. Cation exchange chromatography, with a sodium borate buffer mobile phase, was selected as the separation

mode because the two isotopes have slightly different constants in the equilibrium reaction between ammonium ion and ammonia. When the two forms of ammonium were passed separately through a high-performance cation exchange column under precisely controlled chromatographic conditions, the retention time (RT) of $^{15}\text{NH}_4$ was 1.012 times the RT of $^{14}\text{NH}_4$. The two isotopic forms of ammonium ion were not resolved into separate peaks when they were injected together, but the retention time of the combined peak, as defined by an integrator, increased as increasing percentages of $^{15}\text{NH}_4$ in the sample were converted to ammonia, which diffused across a hydrophobic membrane and reacted with an acid-based indicator.

5.5 Antimony

5.5.1 Atomic Absorption Spectrometry

Sturgeon et al. [59] have described a hydride generation atomic absorption spectrometry method for the determination of antimony in seawater. The method uses formation of stibene using sodium borohydride. Stibine gas was trapped on the surface of a pyrolytic graphite coated tube at 250 °C and antimony determined by atomic absorption spectrometry. An absolute detection limit of 0.2 ng was obtained and a concentration detection limit of 0.04 µg/l obtained for 5 ml sample volumes.

5.5.2 Hydride Generation Atomic Absorption Spectrometry

Bertine and Lee [60] have described hydride generation techniques for determining total antimony, Sb (V), Sb (III), Sb-S species and organo-antimony species in frozen seawater samples.

Total Antimony

Total antimony content was analysed by a hydride generation technique utilising a quartz burner with a hydrogen flame. The water sample was made 2 N in hydrochloric acid with a final volume of 100 ml. Two ml of 20% (w/v) potassium iodide were added and the sample degassed using helium as a carrier gas for 100 s. A silanised glass wool trap on which to collect the SbH_3 , was then placed in liquid nitrogen and 2 ml of 5% sodium borohydride were slowly injected over a time period of 100 s. The sample was stripped for 300 s, then the trap was removed from the liquid nitrogen and the hydride was carried to an electrically heated quartz burner with a hydrogen flame. The antimony concentration

was measured using atomic absorption spectrophotometry. Detection limits of about 0.01 ng are obtainable.

Both the hydrochloric acid and sodium borohydride contributed to the blank. The Sb (V) in the 12 N hydrochloric acid was removed by uptake on a Dowex 1-X8 anion exchange resin. Sodium borohydride was purified, after dissolution, by addition of 0.5 ml sodium hydroxide (50%) to 200 ml of 5% sodium borohydride, and subsequent filtration through a hydrochloric acid precleaned 0.45 μm Millipore membrane.

Hydrogen sulfide gas interfered in the determination of antimony since, after the addition of hydrogen sulfide, a peak comes a few seconds after the antimony peak. It was found that either degassing the sample for 300 s or placing lead acetate in the line eliminated the problem without interfering with the antimony determination.

Antimony (III)

Two ml of citrate buffer (purified by an Fe-APDC precipitation) were added to maintain a pH of 5–6. The sample was degassed for 100 s prior to the injection of 2 ml of 5% sodium borohydride. The sample was stripped for 300 s. This procedure gives a complete extraction of antimony (III) and no extraction of antimony (V), even in the presence of hundredfold higher concentrations of antimony (V).

At a pH of 5–6, hydrogen sulfide evolution by degassing proceeds at a much slower rate. Background correction using a hydrogen lamp or lead acetate placed in line was able to remove any interference from the amount remaining after 400 s. However, it was found that the extraction yield of antimony (III) standards prepared in sodium sulfide was not only incomplete but the yield was also inversely proportional to the amount of sulfide added to the standards. It has been hypothesised that in sulfide-rich waters an antimony sulfide complex may exist. A complete yield of antimony (III) in sodium sulfide could be attained by making a 1–2 ml sample 2 N in hydrochloric acid, degassing for 5 min, bringing the volume to 100 ml, adding sufficient Tris-buffer to bring the pH to 6, then proceeding with the hydride generation method as above. No antimony (V), even in thousandfold excess, was detected by the above method.

See also Sects. 5.74.3, 5.74.7, 5.74.9, 5.74.11, 5.74.14 and 5.74.15.

5.6

Arsenic

5.6.1

Spectrophotometric Methods

Afansev et al. [61] have described an extraction photometric method for the determination of arsenic at the $\mu\text{g/l}$ range in seawater. This method uses diantipyrimethane as the chromogene reagent. The coefficient of variation is

2.5% for arsenic concentrations in the 1.5–5 $\mu\text{g/l}$ range. Good agreement was obtained with results obtained by neutron activation analysis.

A UK standard official method [62] has been published for the spectrophotometric determination of arsenic in sea water. The determination is effected by conversion to arsine using sodium borohydride which is added slowly to the acidified samples by a peristaltic pump. The liberated arsine is trapped in an iodine/potassium iodide solution and the resultant arsenate determined spectrophotometrically as the arsenomolybdenum blue complex at 866 nm. The method is applicable down to 0.19 μg arsenic.

5.6.2

Atomic Absorption Spectrometry

Bermejo–Barrera et al. [64] studied the use of lanthanum chloride and magnesium nitrate as modifiers for the electrothermal atomic spectrometric determination of $\mu\text{g/l}$ levels of arsenic in seawater.

Howard and Comber [63] converted arsenic in seawater to its hydride prior to determination by atomic absorption spectrometry.

Electrothermal atomic absorption spectrometry is used to study the total arsenic and arsenic (III) content in marine sediments [64].

Burton and coworkers [65] have studied the distribution of arsenic in the Atlantic Ocean. Samples from 1000 m and above were filtered through acid-washed 0.45 μm Sartorius membrane filters. Analyses on samples from depths below 1000 m were made on unfiltered water.

Aliquots of 50 ml were placed in a round-bottomed flask, fitted with a modified Dreschel head and an injection syringe in a side arm. Concentrated hydrochloric acid 20 ml, 1 ml of 1 M ascorbic acid solution and 1 ml 1 M potassium iodide solution were added. The solution was stood for 30 min to allow reduction of As^{V} to As^{III} which was necessary to ensure quantitative recovery of inorganic arsenic as arsine under the conditions used in the subsequent step. With nitrogen passing through the flask at a flow rate of 150 ml/min, 0.5 ml 8% w/v sodium borohydride solution was added from the syringe. The arsine evolved was trapped in 2 ml of a solution containing 0.7% w/v potassium iodide, over a period of 3 min.

The concentrates were subsequently analysed for arsenic using Varian-Techtron AAS atomic absorption spectrophotometer fitted with a Perkin-Elmer HGA 72 carbon furnace, linked to a zinc reductor column for the generation of arsine (Fig. 5.3). A continuous stream of argon was allowed to flow with the column connected into the inert gas line between the HGA 72 control unit and the inlet to the furnace. Calcium sulfate (10–20 mesh) was used as an adsorbent to prevent water vapour entering the carbon furnace. The carbon tube was of 10 mm id and had a single centrally located inlet hole.

A wide range of elements was tested for interfering effects; the only significant interferences found were at concentrations much higher than those

Figure 5.3. Zinc reactor column for generation of arsine by electrothermal atomic absorption spectrophotometry. Source: Author's own files

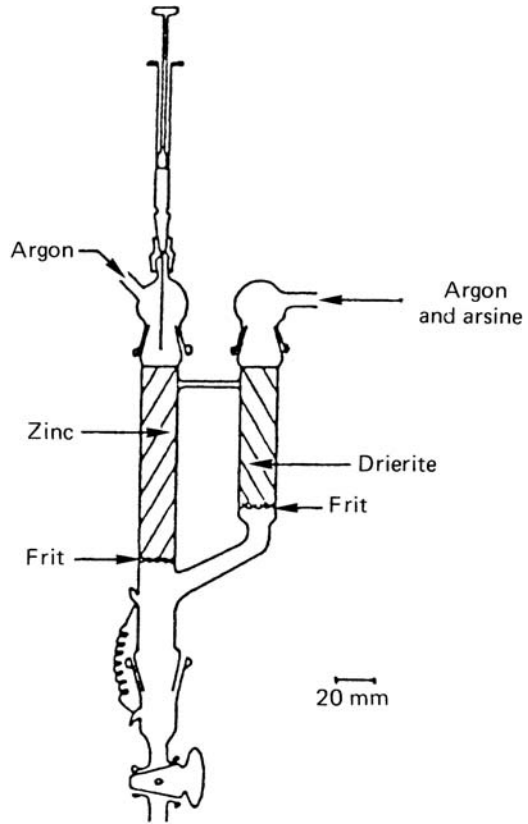

encountered in seawater. No significant difference in the results were found when a sample of seawater was analysed in the way described and also by the same procedure but using the method of standard additions.

5.6.3 Neutron Activation Analysis

The neutron activation method for the determination of arsenic and antimony in seawater has been described by Ryabin et al. [66]. After coprecipitation of arsenic acid and antimony in a 100 ml sample of water by adding a solution of ferric iron (10 mg iron per litre) followed by aqueous ammonia to give a pH of 8.4, the precipitate is filtered off and, together with the filter paper, is wrapped in a polyethylene and aluminium foil. It is then irradiated in a silica ampoule in a neutron flux of 1.8×10^{13} neutrons $\text{cm}^{-2} \text{s}^{-1}$ for 1–2 h. Two days after irradiation, the γ -ray activity at 0.56 MeV is measured with use of a NaI (Tl) spectrometer coupled with a multichannel pulse-height analyser, and compared with that of standards.

Yusov et al. [67] separated arsenic (III) and arsenic (V) in seawater using a chloroform solution of ammonium pyrrolidine diethylthiocarbamate. The separated fractions were then analysed by neutron activation analysis.

5.6.4

Inductively Coupled Plasma Mass Spectrometry

Creed et al. [68] described a hydride generation inductively coupled plasma mass spectrometric method featuring a tubular membrane gas-liquid separator for the determination of down to 100 pg of arsenic in seawater.

Klane and Blum [69] showed that inductively coupled plasma spectrometry was able to determine below 1000 ng/l of arsenic in seawater. Ion exclusion chromatography coupled with inductively coupled plasma mass spectrometry has been used to determine several arsenic species in seawater [947]. Down to 3 ng/l arsenic can be determined using hydride generation prior to this technique.

5.6.5

Anodic Stripping Voltammetry

Jaya et al. [70] carried out an anodic stripping voltammetric determination of arsenic (III) at a copper-coated glassy electrode. The deposition of copper on the electrode made it sensitive to the presence of arsenic (III) and suitable for use by anodic stripping voltammetry analysis. The height of the stripping peak was linearly dependent on the concentration of arsenic (III) in the solution for 7.5–750 $\mu\text{g/l}$ arsenic (III). Lead, zinc, cadmium, manganese, and thallium did not cause significant interference, but bismuth did. The method gave 92–106% arsenic recovery when tested on synthetic seawater samples, and on natural arsenic-free seawater spiked with arsenic at levels of 10 and 20 ng per litre.

Hua et al. [71] carried out automated determination of total arsenic in seawater by flow constant-current stripping with gold fibre electrodes in which the sample was acidified and pentavalent arsenic was reduced to the trivalent form with iodide. The arsenic was then deposited potentiostatically for 4 min on a 25 μm gold fibre electrode, and subsequently stripped with constant current in 5 M hydrochloric acid. Cleaning and regeneration of the gold electrode were fully automated.

Huiliang et al. [72] have described a flow potentiometric and constant-current stripping analysis for arsenic (V) without prior chemical reduction to arsenic (III). Details are given of procedure for determination of pentavalent arsenic by means of flow potentiometry and constant-current stripping analysis. It involved reduction of arsenic to the element state on a gold-plated platinum fibre electrode at very low reduction potential, and subsequent re-oxidation either by means of a constant current, or chemically using gold as oxidant. Methods for applying this technique to determination of total arsenic in acidified seawater are presented.

5.6.6

X-ray Fluorescence Spectroscopy

Becker et al. [73] have described a method for the determination of dissolved arsenic in seawater at $\mu\text{g/l}$ levels by precipitation and energy dispersive X-ray fluorescence spectroscopy. Arsenic was precipitated as magnesium ammonium arsenate with magnesium ammonium phosphate as carrier. The precipitate was collected on a glass fibre filter. An energy-dispersive X-ray spectrometer with a rhodium primary target operated at 60 kV and 2 mA and a silver secondary target was used to measure arsenic. Reagents were optimised for 200 ml samples, and arsenic recovery was greater when 3 ml of phosphate carrier was used. The limit of detection was 0.7 $\mu\text{g/l}$. The method was suitable for all types of natural waters, including seawater.

See also Sects. 5.74.3, 5.74.6, 5.74.7, 5.74.9, 5.74.14, and 5.74.15.

5.7

Barium

Barium is of oceanographic interest since it is a nonconservative stable trace element. In spite of the short 10 000 year oceanic residence time for barium, ocean biology largely determines its distributions in the ocean interior. Dissolved concentrations in the major oceans-mapped as part of the GEOSECS programme lie in the range 20–200 nmol/kg (5.6–28 $\mu\text{g/l}$), and profiles show the lowest concentrations near the surface and enrichment at depth in a fashion similar (but not identical) to the distribution of the nutrient element silicon. Its determination to a precision of better than 1% by isotope dilution mass spectrometry has earned barium the distinction of being the “best measured” nutrient-like trace metal in seawater [74].

5.7.1

Atomic Absorption Spectrometry

Bishop [75] determined barium in seawater by direct injection Zeeman-modulated graphite furnace atomic absorption spectrometry. The $\text{V}_2\text{O}_3/\text{Si}$ modifier added to undiluted seawater samples promotes injection, sample drying, graphite tube life, and the elimination of most seawater components in a slow char at 1150–1200 °C. Atomisation is at 2600 °C. Detection is at 553.6 nm and calibration is by peak area. Sensitivity is 0.8 absorbance s/ng ($M_0 = 5.6$ pg 0.0044 absorbance s) at an internal argon flow of 60 ml/min. The detection limit is 2.5 pg barium in a 25 ml sample or 0.5 pg using a 135 ml sample. Precision is 1.2% and accuracy is 23% for natural seawater (5.6–28 $\mu\text{g/l}$). The method works well in organic-rich seawater matrices and sediment porewaters.

Epstein and Zander [76] used graphite furnace atomic absorption spectrometry for the direct determination of barium in seawater and estuarine

water. Roe and Froelich [81] achieved a detection of 30 pg barium for 50 μl injections of seawater using direct injection graphite furnace atomic absorption spectrometry.

Dehairs et al. [78] describe a method for the routine determination of barium in seawater using graphite furnace atomic absorption spectrometry. Barium is separated from major cations by collection on a cation exchange column. The barium is removed from this resin with nitric acid. Recoveries are greater than 99%.

5.8 Beryllium

5.8.1 Graphite Furnace Atomic Absorption Spectrometry

Okutani et al. [79] have achieved a rapid and simple preconcentration of beryllium by selective adsorption using activated carbon as an adsorbent and acetylacetonone as a complexing agent. The method has been used for the determination of a trace amount of beryllium by graphite furnace atomic absorption spectrometry. The beryllium-acetylacetonate complex is adsorbed easily onto activated carbon at pH 8–10. The activated carbon which adsorbed the beryllium-acetylacetonate complex was separated and dispersed in pure water. The resulting suspension was introduced directly into the graphite furnace atomiser. The determination limit was 0.6 ng/l ($S/N = 3$), and the relative standard deviation at 0.25 $\mu\text{g/l}$ was 3.0–4.0% ($n = 6$). Not only was there no interference from the major ions such as sodium, potassium, magnesium, calcium, chloride, and sulfate in seawater, but there was also no interference from other minor ions. The method was applied to the determination of nanograms per millilitre levels of beryllium in seawater and rainwater.

5.8.2 Miscellaneous

Other methods reported for the determination of beryllium include UV-visible spectrophotometry [80, 81, 83], gas chromatography (GC) [82], flame atomic absorption spectrometry (AAS) [84–88] and graphite furnace (GF) AAS [89–96]. The ligand acetylacetonone (acac) reacts with beryllium to form a beryllium-acac complex, and has been extensively used as an extracting reagent of beryllium. Indeed, the solvent extraction of beryllium as the acetylacetonate complex in the presence of EDTA has been used as a pretreatment method prior to atomic absorption spectrometry [85–87]. Less than 1 μg of beryllium can be separated from milligram levels of iron, aluminium, chromium, zinc, copper, manganese, silver, selenium, and uranium by this method. See also Sect. 5.74.9.

5.9

Bismuth

5.9.1

Atomic Absorption Spectrometry

Shijo et al. [95] converted bismuth in seawater into its dithiocarbamate complex, and then extracted the complex into xylene prior to determination in amounts down to 0.3 ppt by electrothermal atomic absorption spectrometry.

Soo [96] determined picogram amounts of bismuth in seawater by flameless atomic absorption spectrometry with hydride generation. The bismuth is reduced in solution by sodium borohydride to bismuthine, stripped with helium gas, and collected in situ in a modified carbon rod atomiser. The collected bismuth is subsequently atomised by increasing the atomiser temperature and detected by an atomic absorption spectrophotometer. The absolute detection limit is 3 pg of bismuth. The precision of the method is 2.2% for 150 pg and 6.7% for 25 pg of bismuth. Concentrations of bismuth found in the Pacific Ocean ranged from < 0.003 – 0.085 (dissolved) and 0.13 – 0.2 ng/l (total).

Gilbert and Hume [97], Florence [98], and Eskilsson and Jaguar [99] have applied anodic stripping voltammetry to the determination of bismuth in seawater. Gilbert and Hume [97] and Florence [98] investigated the electro-analytic chemistry of bismuth (III) in the marine environment using linear-sweep anodic stripping voltammetry and a film of mercury on a glassy carbon [98] or a graphite [97] substrate as working electrode. Gillain et al. [100] used differential-pulse anodic stripping voltammetry with a hanging mercury drop electrode for the simultaneous determination of antimony (III) and bismuth (III) in seawater.

In the method of Gilbert and Hume [97], the sample contained in a silica cell was purged and stirred by passage of purified nitrogen. A platinum counter-electrode was used. The reference electrode consisted of a silver wire, previously anodised in seawater, held in a borosilicate glass tube containing a small untreated portion of the sample that was separated from the sample being analysed by a plug of unfused Vycor. To diminish the effect of the steeply rising background current ($0.1 \mu\text{A s}^{-1}$) on the stripping peaks, a compensating circuit was devised. Bismuth was deposited at -0.4 V from seawater made 1 M in hydrochloric acid and gave a stripping peak of -0.2 V, the height of which was proportional to concentration without interference from antimony or metals normally present. Antimony was deposited at -0.5 V from seawater made 4 M in hydrochloric acid and gave a stripping peak at -0.3 V, the area of which was proportional to the sum of antimony and bismuth. By use of the standard-addition technique, satisfactory results were obtained for the concentration ranges 0.2 – $0.09 \mu\text{g kg}^{-1}$ for bismuth and 0.2 – $0.5 \mu\text{g kg}^{-1}$ for antimony.

Florence [98] carried out anodic stripping voltammetry of bismuth in a weakly acidic medium, with a polished vitreous carbon electrode mercury-

plated in situ. The limit of detection is 5 ng bismuth per litre. Seawater was found to contain 0.02–0.11 μg bismuth per litre in surface samples.

Since computerised potentiometric stripping analysis [101–103] is in many respects a simpler analytical technique than linear-sweep or differential-pulse anodic stripping voltammetry, it is used for the potentiometric stripping determination of bismuth (III). Although only data for the determination of bismuth (III) in seawater are reported in this paper, the optimum experimental conditions with respect to sample matrix, interferences, limits of detection, and other experimental parameters can be applied to samples other than saline waters. During the course of his work it became apparent that the surface Kattagatt samples analysed during this investigation contained approximately one order of magnitude less bismuth (III) than the results obtained hitherto by electroanalytical [97,98,100] and ion exchange [104] techniques. Because the direct determination of such low concentrations of bismuth in seawater by means of potentiometric stripping analysis would be somewhat time-consuming, a simple preconcentration technique was used. This technique was based on the coprecipitation of bismuth (III) with magnesium hydroxide, thus taking advantage of the naturally high magnesium concentration in seawater [105,106].

Square-wave anodic stripping voltammetry was employed by Komorsky-Lovric [107] for the determination of bismuth in seawater. A bare glassy-carbon rotating disk electrode was preconditioned at -0.8 V versus Ag/AgCl, prior to concentration of bismuth. The method was applied to seawater in the 12 ng/l range.

See also Sects. 5.74.5, 5.74.7, 5.74.8, 5.74.10, and 5.74.11.

5.10 Boron

5.10.1 Spectrophotometric Methods

Various chromogenic reagents have been used for the spectrophotometric determination of boron in seawater. These include curcumin [108,109], Nile blue [110], and more recently 3,5 di-tert butylcatechol and ethyl violet [111]. Uppstroem [108] added anhydrous acetic acid (1 ml) and propionic anhydride (3 ml) to the aqueous sample (0.5 ml) containing up to 5 mg of boron per litre as H_3BO_3 in a polyethylene beaker. After mixing and the dropwise addition of oxalyl chloride (0.25 ml) to catalyse the removal of water, the mixture is set aside for 15–30 minutes and cooled to room temperature. Subsequently, concentrated sulfuric–anhydrous acetic acid (1:1) (3 ml) and curcumin reagent (125 mg curcumin in 100 ml anhydrous acetic acid) (3 ml) are added, and the mixed solution is set aside for at least 30 minutes. Finally 20 ml standard buffer solution (90 ml of 96% ethanol, 180 g ammonium acetate – to destroy excess of protonated curcumin – and 135 ml anhydrous acetic acid diluted to 1 litre

with water) is added, the mixture is cooled to room temperature, and the extinction is measured at 545 nm. For less than 0.01 mg boron per litre, the coloured complex must be concentrated: a portion of sample (2–10 ml) in which the colour reaction has taken place is diluted with water (100 ml), and the complex is extracted into 5 or 10 ml of extractant (100 ml isobutyl methyl ketone, 150 ml of chloroform, and 1 g phenol). The extinction of the organic phase is measured at 545 nm. The colour of the complex is stable for about 2 h. Interference is caused by germanium and fluoride. Small amounts of water are tolerated, but they reduced the efficiency of the method.

A curcumin-based automated version of the above procedure [78] has been described [79]. Determinations can be made in the range 0.1–6 mg boron per litre. At a level of 3 mg/l the coefficient of variation was 1.5% and the detection limit was 0.01 mg/l. Up to 240 samples per hour can be processed by the procedure.

In the Nile blue spectrophotometric method, 10 ml 2% aqueous hydrofluoric acid is added to a 10 ml sample contained in a polyethylene bottle. The mixture is shaken for about 2 h. Aqueous ferrous *sulfate* 10% 10 ml and 1 ml 0.1% aqueous Nile blue A are added, then extracted with *o*-dichlorobenzene (10 ml and 3 × 5 ml). The combined organic extracts are diluted to 50 ml with the solvent and the extinction measured at 647 nm. Interference from chloride ions up to 100 mg/l can be eliminated by precipitation as silver chloride.

Marcantoncetos et al. [112] have described a phosphorimetric method for the determination of traces of boron in seawater. This method is based on the observation that in the “glass” formed by ethyl ether containing 8% of sulfuric acid at 77 K, boric acid gives luminescent complexes with dibenzoylmethane. A 0.5 ml sample is diluted with 10 ml 96% sulfuric acid, and to 0.05–0.3 ml of this solution 0.1 ml 0.04 M dibenzoylmethane in 96% sulfuric acid is added. The solution is diluted to 0.4 ml with 96% sulfuric acid, heated at 70 °C for 1 h, cooled, ethyl ether added in small portions to give a total volume of 5 ml, and the emission measured at 77 K at 508 nm, with excitation at 402 nm. At the level of 22 ng boron per ml, hundredfold excesses of 33 ionic species give errors of less than 10%. However, tungsten and molybdenum both interfere.

5.10.2

Atomic Absorption Spectrometry

Atomic absorption spectrometry has been used for the rapid determination of boron in seawater [113].

5.10.3

Coulometry

Tsaikov [114] has described a coulometric method for the determination of boron in coastal seawaters. This method is based on the potentiometric titra-

tion of boron with electrogenerated hydroxyl ions, after removal of the cation components by ion exchange. The method has good reproducibility and is more accurate than other methods; it is also fairly rapid (25–30 minutes per determination).

5.11 Cadmium

In the determination of cadmium in seawater, for both operational reasons and ease of interpretation of the results it is necessary to separate particulate material from the sample immediately after collection. The “dissolved” trace metal remaining will usually exist in a variety of states of complexation and possibly also of oxidation. These may respond differently in the method, except where direct analysis is possible with a technique using high-energy excitation, such that there is no discrimination between different states of the metal. The only technique of this type with sufficiently low detection limits is carbon furnace atomic absorption spectrometry, which is subject to interference effects from the large and varying content of dissolved salts.

5.11.1 Atomic Absorption Spectrometry

Various workers have discussed the application of graphite furnace atomic absorption spectrometry to the determination of cadmium in seawater [115–124].

Batley and Farrah [120] and Gardner and Yates [118] used ozone to decompose organic matter in samples and thus break down metal complexes prior to atomic absorption spectrometry. By this treatment, metal complexes of humic acid and EDTA were broken down in less than 2 min. These observations led Gardner and Yates [118] to propose the following method for the determination of cadmium in seawater.

The sample is filtered immediately after collection, acidified to about pH 2, and transferred to a 1-litre Pyrex storage bottle. Prior to extraction the sample is ozonised in the sample bottle for 30 minutes. Nitrogen is passed through the sample for 5 minutes to remove excess ozone, then the pH is carefully raised to about 5 by addition of ammonia solution, and about 5 ml Chelex 100 resin in the ammonia form is added. After stripping for at least 1 h, the resin is collected in a Pyrex chromatography column and washed with the calculated quantity of an appropriate buffer to elute calcium and magnesium. After further washing with 50 ml deionised water, the resin is eluted with 2 M nitric acid to a volume of 25 ml. The elute is analysed by graphite furnace atomic absorption spectrometry.

Danielson et al. [119] have described a method for the determination of cadmium in seawater. The samples were analysed by graphite furnace atomic

absorption spectroscopy after a two-stage extraction. Replacing the acetate buffer and performing the extraction in a clean room with Teflon utensils significantly improved blank levels. Extractions were performed on board ship immediately after sampling, and the extracts brought home for analysis. An aliquot of the sample was also transferred into carefully cleaned Teflon FEP bottles and acidified with 1 ml of nitric acid per litre. The nitric acid was purified by sub-boiling distillation. These samples were extracted about two months after sampling at the shore laboratory. The same method was used with the exception that extra ammonia was added to the buffer to compensate for the acidification. The method was applied to arctic seawaters, and showed a profile of cadmium with sampling depth ranging from 0.133 nmol/l cadmium at the surface to 0.205 nmol/l cadmium at 2000 m.

As cadmium is one of the most sensitive graphite furnace atomic absorption determinations, it is not surprising that this is the method of choice for the determination of cadmium in seawater. Earlier workers separated cadmium from the seawater salt matrix prior to analysis. Chelation and extraction [121–128], ion exchange [113, 124, 125, 129], and electrodeposition [130, 131] have all been studied.

The direct determination of cadmium in seawater is particularly difficult because the alkali and alkaline earth salts cannot be fully charred away at temperatures that will not also volatilise cadmium. Most workers in the past [125, 132–135] who have attempted a direct method have volatilised the cadmium at temperatures which would leave sea salts in the furnace. This required careful setting of temperatures, and was disturbed by situations that caused temperature settings to change with the life of the furnace tubes.

Lundgren et al. [132] showed that the cadmium signal could be separated from a 2% sodium chloride signal by atomising at 820 °C, below the temperature at which the sodium chloride was vaporised. This technique has been called selective volatilisation. They detected 0.03 µg/l cadmium in the 2% sodium chloride solution. They used an infrared optical temperature monitor to set the atomisation temperature accurately.

Campbell and Ottaway [136] also used selective volatilisation of the cadmium analyte to determine cadmium in seawater. They could detect 0.04 µg/l cadmium (2 pg in 50 µl) in seawater. They dried at 100 °C and atomised at 1500 °C with no char step. Cadmium was lost above 350 °C. They could not use ammonium nitrate because the char temperature required to remove the ammonium nitrate also volatilised the cadmium. Sodium nitrate and sodium and magnesium chloride salts provided reduced signals for cadmium at much lower concentrations than their concentration in seawater if the atomisation temperature was in excess of 1800 °C. The determination required lower atomisation temperatures to avoid atomising the salts. Even this left the magnesium interference, which required the method of additions.

Guevremont et al. [117] used a direct, selective volatilisation determination of cadmium in seawater. They used 20 µl seawater samples, 1 g/l of EDTA, an

atomisation ramp from 250 °C to 2500 °C in 5 s, and the method of additions. Their detection limit was 0.01 µg/l (0.2 pg in 20 µl), and the characteristic amount was 0.7 pg/0.0044 A. The EDTA promoted the early atomisation of cadmium below 600 °C. Their test seawater sample (0.053 µg/l) was confirmed by other methods. These authors were able to separate reliably the cadmium and background signals by using the method of Campbell and Ottaway [136]; the EDTA made this possible.

Guevremont et al. [117] studied the use of various matrix modifiers in the graphite furnace gas method of determination of cadmium in seawater. These included citric acid, lactic acid, aspartic acid, histidine, and EDTA. The addition of less than 1 mg of any of the compounds to 1 ml seawater significantly decreased matrix interference. Citric acid achieved the highest sensitivity and reduction of interference, with a detection limit of 0.01 µg cadmium per litre.

In similar work, Sturgeon et al. [125] compared direct furnace methods with extraction methods for cadmium in coastal seawater samples. They could measure cadmium down to 0.1 µg/l. They used 10 µg/l ascorbic acid as a matrix modifier. Various organic matrix modifiers were studied by Guevremont [116] for this analysis. He found citric acid to be somewhat preferable to EDTA, aspartic acid, lactic acid, and histidine. The method of standard additions was required. The standard deviation was better than 0.01 µg/l in a seawater sample containing 0.07 µg/l. Generally, he charred at 300 °C and atomised at 1500 °C. This method required compromise between char and atomisation temperatures, sensitivity, heating rates, and so on, but the analytical results seemed precise and accurate. Nitrate added as sodium nitrate delayed the cadmium peak and suppressed the cadmium signal.

Sperling [133] has reported extensively on the determination of cadmium in seawater, as well as in other biological samples and materials. He added ammonium persulfate, which permitted charring seawater at 430 °C without loss of cadmium. For work below 2 µg/l cadmium in seawater he recommended extraction of the cadmium to separate it from the matrix [126, 134, 135]. He found no change in the measured levels over many months when the seawater was stored in high-density polyethylene or polypropylene.

Pruszkowska et al. [135] described a simple and direct method for the determination of cadmium in coastal water utilizing a platform graphite furnace and Zeeman background correction. The furnace conditions are summarised in Table 5.1. These workers obtained a detection limit of 0.013 µg/l in 12 µl samples, or about 0.16 pg cadmium in the coastal seawater sample. The characteristic integrated amount was 0.35 pg cadmium per 0.0044 A s. A matrix modifier containing di-ammonium hydrogen phosphate and nitric acid was used. Concentrations of cadmium in coastal seawater were calculated directly from a calibration curve. Standards contained sodium chloride and the same matrix modifier as the samples. No interference from the matrix was observed.

Seawater samples usually contain a total of 2–3% of several alkali and alkaline earth salts, with sodium chloride as a main constituent. A 2 µl sample of

Table 5.1. Zeeman graphite Furnace Conditions

	Dry	Char	Atomise	Clean-out	Cool
Temperature, °C	160	550	1600	2600	20
Ramp, s	1	1	0	1	1
Hold, s	60	45	5	6	20
Internal gas flow, ml/min	300	300	0	300	300
Recorder, s			-5		

From [135]

seawater charred at 700 °C has a background signal so high that even the Zeeman correction system cannot handle it (Fig. 5.4). The largest amounts of sodium chloride present in seawater are reportedly volatilised below 950 °C [137], but even with ammonium phosphate, the matrix modifier recommended for cadmium, it is not possible to char at so high a temperature. Figure 5.4 shows that 200 µg of di-ammonium hydrogen phosphate reduced the SB signal of

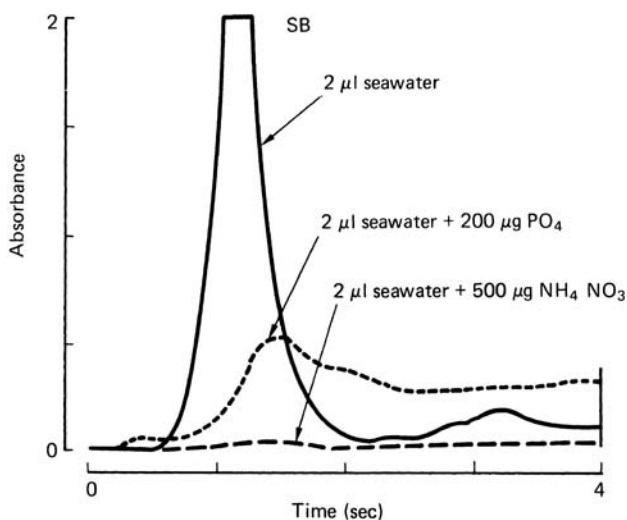

Figure 5.4. Background (SB) profiles for 2 µl seawater alone, with 200 µg $(\text{NH}_4)_2\text{HPO}_4$ and with 500 µg NH_4NO_3 . The char temperature was 700 °C and the atomisation temperature was 1700 °C. The signals from the Data System 10 reported here are called ZAA signals for the analytical result, and SB (single beam) signals for the backgrounds. The SB signals are expressed in absorbance units (A) and the ZAA signals are usually in absorbance unit – seconds (A-s). The SB signal is signal plus background, but for the small analyte signals of this study, the SB signal is effectively background. The actual integrated absorbance signals that were used were calculated by software on the Data Station 10 from signals transmitted by the Zeeman/5000. The plots in later figures show typical signals, but were not used for quantitative evaluation. Source: [135]

2 μl seawater to 0.5 A, but 500 μg ammonium nitrate reduced the background more effectively to 0.16 A. No reduction of the cadmium signal occurred in the presence of ammonium nitrate if the char temperature was below 600 $^{\circ}\text{C}$, and phosphate was used as a matrix modifier. If ammonium nitrate was used without phosphate, the cadmium was lost at temperatures below 500 $^{\circ}\text{C}$. The addition of the phosphate stabilised the cadmium, while the ammonium nitrate promoted the release or conversion of the bulk of the material responsible for the background. The addition of the phosphate produced a background signal that appeared much later than the cadmium peak.

It was shown that 1.25 mg ammonium nitrate is enough to keep the background signal below 1.5 A, and there are no large differences in background absorbances for amounts from 1.25 to 7.5 mg ammonium nitrate.

It was also shown that 2% nitric acid reduced the background to a level that can be handled by the Zeeman correction system. From 4% to 8% nitric acid, the changes in background signal shapes were not very large.

Typical sample (ZAA) signals and background (SB) signals for a seawater sample are shown in Fig. 5.5. Brewer [138] has used electrically vaporised thin gold film atomic emission spectrometry to determine cadmium at the 10 ppb level in highly acidic saline solutions following preconcentration on a strong-base anion exchange resin.

Knowles [139] used extraction with ammonium pyrrolidine dithiocarbamate dissolved in methyl isobutyl ketone to extract cadmium from seawater

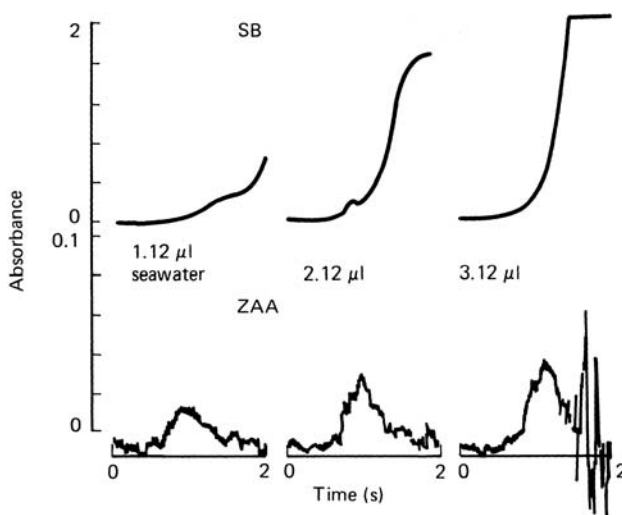

Figure 5.5. Zeeman profiles of a seawater sample (Sandy Cove N.9) and Sb profiles. The *first pair* of profiles represents a single 12 μl aliquot, the *second pair*, two aliquots, and the *third pair*, three aliquots. The modifier was 200 μg $(\text{NH}_4)_2\text{HPO}_4$, 8% HNO_3 , and 5 μg $\text{Mg}(\text{NO}_3)_2$. The char temperature was 550 $^{\circ}\text{C}$, and the atomisation temperature 1600 $^{\circ}\text{C}$. Source: [135]

prior to analysis by Zeeman atomic absorption spectrometry. The method was capable of determining $0.04 \mu\text{g/l}$ of cadmium in seawater when concentration factors of 100 were used.

Three Zeeman-based methods for the determination of cadmium in seawater were investigated. Direct determinations can be made with or without the use of a pyrolytic platform atomisation technique. The wall atomisation methods presented were considerably faster than the platform atomisation technique. For extremely low levels of cadmium, indirect methods of analysis employing a preliminary analyte extraction can be employed. Background levels are minimal in extracted samples, and the total furnace programme time was the lowest of the methods examined.

Lum and Callaghan [140] did not use matrix modification in the electrothermal atomic absorption spectrophotometric determination of cadmium in seawater. The undiluted seawater was analysed directly with the aid of Zeeman effect background correction. The limit of detection was 2 ng/l .

Electrothermal atomic absorption spectrophotometry with Zeeman background correction was used by Zhang et al. [141] for the determination of cadmium in seawater. Citric acid was used as an organic matrix modifier and was found to be more effective than EDTA or ascorbic acid. The organic matrix modifier reduced the interferences from salts and other trace metals and gave a linear calibration curve for cadmium at concentrations $\leq 1.6 \mu\text{g/l}$. The method has a limit of detection of $0.019 \mu\text{g/l}$ of cadmium and recoveries of 95–105% at the $0.2 \mu\text{g}$ of cadmium level.

Lum and Callaghan [140] determined down to 2 ng/l of cadmium directly in seawater by atomic absorption spectrometry with Zeeman correction.

Han et al. [142] have reported an atomic absorption spectrometric method for the determination of cadmium in seawater using sodium phosphate for matrix modification.

5.11.2

Anodic Stripping Voltammetry

Stolzberg [143] has reviewed the potential inaccuracies of anodic stripping voltammetry and differential pulse polarography in determining trace metal speciation, and thereby bio-availability and transport properties of trace metals in natural waters. In particular it is stressed that nonuniform distribution of metal–ligand species within the polarographic cell represents another limitation inherent in electrochemical measurement of speciation. Examples relate to the differential pulse polarographic behaviour of cadmium complexes of NTA and EDTA in seawater.

In a method described by Yoshimura and Uzawa [144], cadmium in seawater is coprecipitated with zirconium hydroxide ($\text{Zr}(\text{OH})_4$) prior to determination by square-wave polarography. The precipitate is dissolved in hydrochloric acid, and cadmium concentration is determined from the peak height of the

polarogram at -0.64 V. The calibration curve was linear for concentrations of ≤ 5.0 μg of cadmium.

Kounaves and Zirino [145] studied cadmium–EDTA complex formation in seawater using computer-assisted stripping polarography. They showed that the method is capable of determining the chemical speciation of cadmium in seawater at concentrations down to 10^{-8} M.

Turner et al. [146] studied the automated electrochemical stripping of cadmium in seawater.

See Sects. 5.74.4–5.74.6, 5.74.8–5.74.12, and 5.74.14–5.74.16.

5.12

Caesium

Nuclear activities such as electricity production by nuclear power plants, or accidents such as occurred at Chernobyl, release radionuclides, including caesium, into the environment. The caesium concentrations in these matrices is very low, so that in addition to a sensitive analytical method, it is necessary to make use of an enrichment technique to bring the caesium concentration within the scope of the analytical method.

5.12.1

Atomic Absorption Spectrometry

Atomic absorption spectrometry is suitable as a method of analysis of the concentrate, and is applicable to radioactive and non-radioactive forms of the element.

For the enrichment of caesium from seawater and other types of sample, Frigieri et al. [147] used ammonium hexacyanocobalt ferrate. This was chosen because it can be employed in strongly acidic solutions, with the exception of concentrated sulfuric acid.

Atomic absorption spectrometry has been used to determine caesium in seawater. The method uses preliminary chromatographic separation on a strong cation exchange resin, ammonium hexacyanocobalt ferrate, followed by electrothermal atomic absorption spectrometry. The procedure is convenient, versatile, and reliable, although decomposition products from the exchanger, namely iron and cobalt, can cause interference.

Caesium is fully retained by a chromatographic column of ammonium hexacyanocobalt ferrate, and can be recovered by dissolution of the ammonium hexacyanocobalt ferrate in hot 12 M sulfuric acid.

As iron and cobalt both interfere with the determination of caesium, using the 852.1 nm caesium line, these elements were removed in a preliminary separation and then caesium determined.

Ganzerli et al. [148] also used copper hexacyanoferrate (II) on a silica support to absorb caesium from both seawater and fresh water. A specific analyt-

ical method is not described, although atomic absorption spectrophotometry might be used.

Shen and Li [149] extracted caesium (and rubidium) from brine samples with 4-tert-butyl-2-(α methyl-benzyl) phenol prior to atomic absorption spectrometric determination of the metal.

See also Sect. 5.74.16.

5.13

Cerium

See Sects. 5.49 and 5.74.15.

5.14

Calcium

5.14.1

Titration Methods

Jagner [150] used computerised photometric titration in a high-precision determination of calcium in seawater.

Calcium is titrated with EGTA (1,2-bis-(2-aminoethoxyethane N,N,N',N' -tetracetic acid) in the presence of the zinc complex of zincon as indirect indicator for calcium. Theoretical titration curves are calculated by means of the computer program HALTAFALL in order to assess accuracy and precision. The method gives a relative precision of 0.00028 when applied to estuarine water of 0.05–0.35% salinity.

Complexometric titration is considered to be the best method for the determination of calcium, but investigators have differed in the endpoint detection technique used and their evaluation of interference by other alkaline earth elements. Studies using different endpoint techniques, some of which also considered magnesium to calcium ratios in seawater, do not agree on the effect of magnesium on the titration of calcium with EGTA (1,2-bis-(2-aminoethoxyethane NNN^1N^1 -tetra-acetic acid). Table 5.2 lists the findings of some of these studies; the reference cited reports that magnesium either has no effect, causes a positive interference, and, in one case, has a negative interference.

In most cases where strontium interference was evaluated, a positive interference was found, but the degree of correction (of the calcium titre) varied from about –0.38% in several studies to –0.7% and –0.88% in other investigations which claim that all or nearly all strontium is co-titrated.

In the light of these observations Olson and Chen [164] decided to use a correction factor for use in their visual endpoint calcium titration method involving titration with EGTA. They found that interferences by magnesium

Table 5.2. Reported studies on determination of calcium using EDTA

Conclusion	Method	Reference
No Mg interference at seawater ratios	Hg electrode	[151]
Positive Mg interference from Mg:Ca = 1.5 and higher	Zn-Zincon	[152]
No Mg interference at seawater ratios	Zn-Zincon	[153]
Titration error if Mg > Ca	Theoretical, Zn-Zincon	[154]
No Mg interference at seawater ratios when end-points sharp	Various chemical visual indicators	[155]
Mg interference of +0.792% on Ca titre; Sr interference of +0.388% on Ca Titre	Zn-Zincon	[156]
Mg interference of -0.23% on Ca titre; Sr interference of +0.77% on Ca titre	GHA	[157]
Sr interference; increased titration error at seawater ratios - dependent on end- point sensitivity	Stability constants 'conditional constants'	[158]
Sr interference of +0.37% on Ca titre	Ca-Red	[159]
Mg interference at seawater ratios	Computer simulated curves of Zn-Zincon	[160]
No Mg interference; Sr interference of 0.9% on Ca titre	Amalgamated Ag electrode	[161]
No Mg interference	Ca ion selective	[162]
No Mg interference; No Sr interference	Ca ion selective	[163]

Source: own files

and strontium were insignificant at the molar ratios normally found in seawater, but is more serious in samples containing higher ratios of magnesium or strontium to calcium. An average value of 0.02103 was obtained for the ratio of calcium to chlorinity in samples of standard seawater.

They used the titration method of Tsunogai et al. [157]. The titrant solutions were standardised against calcium carbonate of primary standard quality (99.9975% purity) rather than zinc, and the EGTA (Eastman Chemicals) was used without further purification.

The presence of normal concentrations of sodium, magnesium, and strontium have no net effect on the determination of calcium above the approximate level of accuracy of about 0.1% so that no correction factor seems necessary. A sufficient amount of titrant must be added to complex at least 98% of dissolved calcium before the buffer is added; this apparently reduces the loss of calcium by coprecipitation with magnesium hydroxide.

Interference effects begin to appear at higher magnesium or strontium molar ratios. Tsunogai et al. [157] found the interference of magnesium to be negative and, for strontium, interference is related to the extraction into the organic layer of the calcium GHA complex. They found a positive interference for strontium at twice the seawater molar ratios. Therefore, the interference of

the individual alkaline earth elements on the calcium titration found by Olson and Chen [164] are consistent in direction, though clearly not in magnitude with those that were reported Tsungai et al. [157]. The presence of sodium (chloride) in the solutions also seems to diminish these interference effects in both cases. Although no explanation was found for the reduced interference effect when sodium is present, it does suggest the advantage of either standardising the titrant against seawater matrix calcium standard or of having some matrix available to evaluate individual interference effects with a procedure to be used for seawater.

5.14.2

Atomic Absorption Spectrometry

Atomic absorption spectrophotometry [165, 166] has been used in the determination of calcium and magnesium in seawater.

5.14.3

Flame Photometry

Blake et al. [167] have described a flame photometric method for the determination of calcium in solutions of high sodium content. The method was applied to simulated seawater. In the method Chelex 100 chelating resin (Na^+ form) (20 g) is stirred with 2 N hydrochloric acid (15 ml) for 5 min, the acid is decanted and the resin is washed with water (2×25 ml), stirred with 2 N sodium hydroxide (15 ml) for 5 min and again washed with water (2×25 ml). The procedure is repeated five times, then the resin is dried at 100°C . A neutral solution (100 ml) containing up to 50 ppm of calcium and up to 4% of sodium is passed through a column of the resin, a specified amount of hydrochloric acid (pH 2.4) is passed through, and the percolate containing the sodium is discarded. Elution is then effected with 2 N hydrochloric acid (5 ml) and the column is washed with water (25 ml), the combined eluate and washings are diluted to 100 ml and calcium is determined by flame photometry at 622 nm. There is no interference from magnesium, zinc, nickel, barium, mercury, manganese, copper or iron present separately in concentrations of 25 ppm or collectively in concentrations of 5 ppm each. Aluminium depresses the amount of calcium found.

5.14.4

Calcium-Selective Electrodes

Whitfield et al. [168] used a calcium-selective electrode to monitor EGTA and DCTA titrations of aqueous mixtures of calcium, magnesium, and sodium. The concentrations were selected to span the range of natural waters and the

results were analysed statistically. The pattern of titration curves observed with changing solution composition agreed qualitatively with that predicted theoretically, but the overall potential drop was usually lower than that predicted; endpoints were determined by graphical and numerical methods. The technique is suitable for the determination of calcium and magnesium in seawater with an estimated accuracy of 0.5%. The electrode also responds to zinc, iron, lead, copper, nickel, and barium. In seawater free from coastal influences the concentration of these elements are too low to cause interference. However, in inshore samples these elements might have to be masked. The titration of calcium in other natural waters by this method should give an accuracy of 1 to 2% which could be improved by adding known amounts of calcium to bring the initial concentration in the sample to a suitable value (e.g. 10^{-2} M).

5.14.5

Inductively Coupled Plasma Atomic Emission Spectrometry

Brenner et al. [169] applied inductively coupled plasma atomic emission spectrometry to the determination of calcium (and sulfate) in brines. The principal advantage of the technique was that it avoided tedious matrix matching of calibration standards when sulfate was determined indirectly by flame techniques. It also avoided time-consuming sample handling when the samples were processed by the gravimetric method. The detection limit was 70 $\mu\text{g/l}$ and a linear dynamic range of 1 g/l was obtained for sulfate.

See also Sects. 5.74.1, 5.74.2, 5.74.14 and 5.74.16.

5.15

Chromium

5.15.1

Total Chromium

Reported concentrations of chromium in open ocean waters range from 0.07 to 0.96 $\mu\text{g/l}$ with a preponderance of values near the lower limit. Methods used for the determination of chromium at this concentration have generally used some form of matrix separation and analyte concentration prior to determination [170–173], electroreduction [174, 175] and ion exchange techniques [176, 177].

Whereas it is desirable to utilise analytical schemes that permit elucidation of the various chromium species particularly since Cr^{VI} is acknowledged to be a toxic form of this element, it is also useful to have the capability of rapid, total chromium measurement.

Determination of chromium by many of the methods cited above is problematic. Variable and nonquantitative recovery with chelation–solvent extraction

techniques necessitates use of the method of additions [173]. Coprecipitation techniques require lengthy processing times and extensive sample manipulation. Ion exchange suffers from slow uptake and release kinetics, necessitating total destruction and solubilisation of the resin [177] or complex apparatus and multicomponent eluting solutions.

Atomic Absorption Spectrometry

As a consequence Willie et al. [178] developed an approach to the determination of total chromium. This involves preliminary concentration of dissolved chromium from seawater by means of an immobilised diphenylcarbazone chelating agent, prior to determination by atomic absorption spectrometry. A Perkin-Elmer Model 500 atomic absorption spectrometer fitted with a HGA-500 furnace with Zeeman background correction capability was used for chromium determinations. Chromium was first reduced to Cr^{III} by addition of 0.5 ml aqueous sulfur dioxide and allowing the solution to stand for several minutes. Aliquots of seawater were then adjusted to $\text{pH } 9.0 \pm 0.2$ by using high-purity ammonium hydroxide and gravity fed through a column of silica at a nominal flow rate of 10 ml/min.

The sequestered chromium was then eluted from the column with 10.0 ml 0.2 M nitric acid. More than 93% of chromium was recovered in the first 5 ml of eluate by this method. Extraction of 80 ng spikes of Cr^{III} from 200 ml aliquots of seawater was quantitative. Neither Cr^{III} nor Cr^{VI} could be quantitatively extracted. Between 0.15 and 0.19 $\mu\text{g/l}$ total chromium was found in seawater by this method compared to the accepted value of $0.184 \pm 0.016 \mu\text{g/l}$.

Moffett [179] determined chromium in seawater by Zeeman corrected graphite tube atomisation atomic absorption spectrometry. The chromium is first complexed with a pentan-2,4 dione solution of ammonium 1 pyrrolidine carbodithioc acid, then this complex extracted from the water with a ketonic solvent such as methyl isobutyl ketone, 4-methylpentan-2-one or diisobutyl ketone.

Recoveries obtained on standard samples are adequate, e.g., US EPA standard 4, quoted $10.2 \pm 1.1 \text{ ng/l}$, found, $9.75 \pm 0.16 \text{ ng/l}$.

Chemiluminescence

Dubovenko et al. [180] used chemiluminescence to determine total chromium in brines. The method is based on the enhancement of the chemiluminescence by chromium in the reaction of 4-(diethylamino) phthalhydrazide with hydrogen peroxide. The detection limit is 0.025 $\mu\text{g/l}$ of chromium, and the chemiluminescence is directly proportional to chromium concentrations in the range 5×10^{-10} to 10^{-6} M .

Isotope Dilution – Mass Spectrometry

Isotope dilution gas chromatography-mass spectrometry has also been used for the determination of ppb of total chromium in seawater [181–183]. The samples were reduced to ensure Cr^{III} and then extracted and concentrated as tris (1,1,1-trifluoro-2,4-pentanediono) chromium (III) $[(\text{Cr}(\text{tfa})_3)]$ into hexane. The $\text{Cr}(\text{tfa})_2^+$ mass fragments were monitored into a selected ion monitoring (SIM) mode.

Isotope dilution techniques are attractive because they do not require quantitative recovery of the analyte. One must, however, be able to monitor specific isotopes which is possible by using mass spectrometry.

In this method, chromium is extracted and pre-concentrated from seawater with trifluoroacetylacetone $[\text{H}(\text{tfa})]$ which complexes with trivalent but not hexavalent chromium. Chromium reacts with trifluoroacetylacetone in a 1:3 ratio to form an octahedral complex, $\text{Cr}(\text{tfa})_3$. The isotopic abundance of its most abundant mass fragment, $\text{Cr}(\text{tfa})_2^+$ was monitored by a quadrupole mass spectrometer.

A mass spectrum of $\text{Cr}(\text{tfa})_3$ is shown in Fig. 5.6. The isotopic distribution of the $\text{Cr}(\text{tfa})_2^+$ fragment (m/e 358 and 359 here) is evident. This is readily calculable if the individual elemental abundances are known. Assuming the isotopic abundance of ^{12}C and ^{13}C to be 98.89% and 1.11 and ^{50}Cr , ^{52}Cr , ^{53}Cr and ^{54}Cr be 4.31, 83.76, 9.55 and 2.38%, respectively, and neglecting any isotopic abundances less than 1%, one can obtain a set of calculated abundances for the $\text{Cr}(\text{tfa})_2^+$ ion. The agreement between the two sets is excellent. Agreement

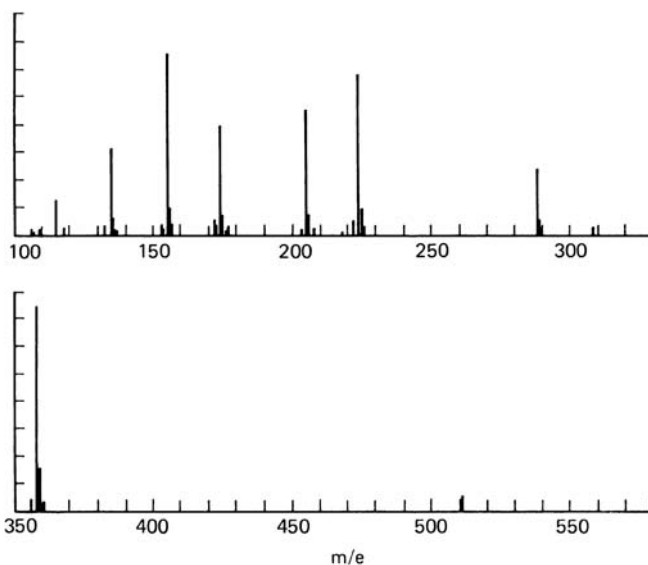

Figure 5.6. Mass spectrum of $\text{Cr}(\text{tfa})_3$. Source: Author's own files

with data obtained by isotope dilution spark source mass spectrometry [184] and graphite furnace [185] was excellent.

5.15.2

Chromium (III)

Anodic Stripping Voltammetry

Boussemart and Van den Berg [186] adsorbed chromium (III) in seawater onto silica, then reoxidised it to chromium (VI) prior to determination in amounts down to 1 pmol/l by a voltammetric procedure.

The chemiluminescence technique has been used to determine trivalent chromium in seawater. Chang et al. [187] showed Luminol techniques for determination of chromium (III) were hampered by a salt interference, mainly due to magnesium ions. Elimination of this interference is achieved by seawater dilution and utilising bromide ion chemiluminescence signal enhancement (Fig. 5.7). The chemiluminescence results were comparable with those obtained by a graphite furnace flameless atomic absorption analysis for the total chromium present in samples. The detection limit is 3.3×10^{-9} mol/l (0.2 ppb) for seawater with a salinity of 35%, with 0.5 M bromide enhancement.

The effect of calcium interference is somewhat different. At its concentration in seawater, 0.010 M, calcium ion had no effect upon chemiluminescence analysis of a 6×10^{-8} M Cr^{III} solution in the absence of bromide ion. The

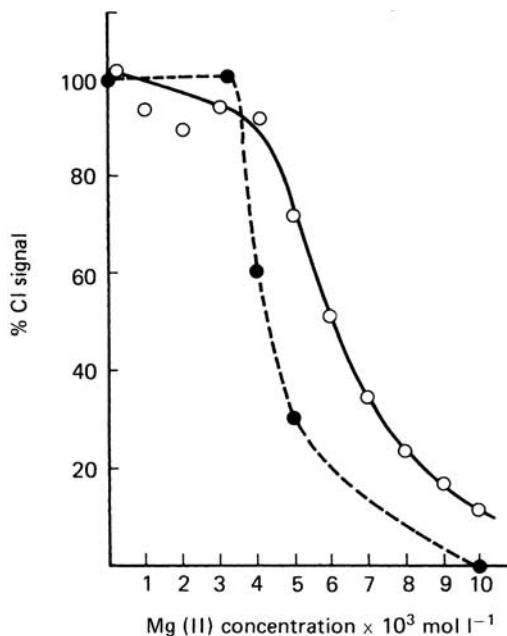

Figure 5.7. Mg^{II} interference of Cl analysis for Cr. -o-o-o = in the presence of 0.3 Br^- ; -●-●-● = in the absence of Br^- . $\text{Cr}^{\text{III}} = 6 \times 10^{-8}$ M. EDTA = 2.5×10^{-3} M. Source: [187]

chemiluminescence signal dropped to zero, however, if the calcium ion concentration was increased to 0.013 M. In the presence of 0.3 M bromide ion, no interference was observed for analysis of 6×10^{-8} M Cr^{III} when the calcium concentration was less than or equal to 0.002 M. The chemiluminescence signal increased linearly with increasing calcium ion concentration when the calcium concentration exceeded 0.002 M.

The combined effect of cation interference for both Mg^{II} and Ca^{II} is almost identical with the solid curve in Fig. 5.7, indicating that the magnesium ion interference is the dominant one.

5.15.3

Chromium (III) and (VI)

Various workers have discussed the separate determination of Cr^{III} and Cr^{VI} in seawater [170–172, 188, 189].

Spectrophotometric Method

Diphenylcarbazone and diphenylcarbazide have been widely used for the spectrophotometric determination of chromium [190]. Cr^{III} reacts with diphenylcarbazone whereas Cr^{VI} reacts (probably via a redox reaction combined with complexation) with diphenylcarbazide [191]. Although speciation would seem a likely prospect with such reactions, commercial diphenylcarbazone is a complex mixture of several components, including diphenylcarbazide, diphenylcarbazone, phenylsemicarbazide, and diphenylcarbadiazone, with no stoichiometric relationship between the diphenylcarbazone and diphenylcarbazide [192]. As a consequence, use of diphenylcarbazone to chelate Cr^{III} selectively also results in the sequestration of some Cr^{VI} . Total chromium can be determined with diphenylcarbazone following reduction of all chromium to Cr^{III} .

Use of immobilised chelating agents for sequestering trace metals from aqueous and saline media presents several significant advantages over chelation–solvent extraction approaches to this problem [193, 194]. With little sample manipulation, large preconcentration factors can generally be realised in relatively short times with low analytical blanks.

Atomic Absorption Spectrometry

Cranston and Murray [171, 188] took the samples in polyethylene bottles that had been precleaned at 20 °C for 4 days with 1% distilled hydrochloric acid. Total chromium (Cr^{VI}) + Cr^{III} + Cr_p (particulate chromium) was coprecipitated with iron (II) hydroxide, and reduced chromium (Cr^{III} + Cr_p) was coprecipitated with iron (III) hydroxide. These coprecipitation steps were completed within minutes of sample collection to minimise storage problems. The iron hydroxide precipitates were filtered through 0.4 μm nucleopore filters and stored

Table 5.3. Determination of dissolved chromium species in some seawaters

Location	Chromium found ($\mu\text{g/l}$)*			
	Cr(III)	Cr(VI)	Cr bound	Cr total
Port Hacking	0.27 ± 0.02	0.49 ± 0.03	0.56 ± 0.07	1.32 ± 0.05
Georges River	0.42 ± 0.04	0.89 ± 0.04	0.42 ± 0.08	1.72 ± 0.06
Drummoyne Bay	0.32 ± 0.03	0.95 ± 0.04	0.69 ± 0.10	1.96 ± 0.07
Botany Bay	0.45 ± 0.04	1.26 ± 0.06	0.71 ± 0.03	2.41 ± 0.09
Cooks River	0.51 ± 0.04	2.98 ± 0.11	0.88 ± 0.10	4.37 ± 0.06
Parramatta River	0.88 ± 0.02	3.17 ± 0.06	0.82 ± 0.09	4.87 ± 0.11

*: all results are the mean (\pm SD) of three measurements

From [189]

in polyethylene vials for later analyses in the laboratory. Particulate chromium was also obtained by filtering unaltered samples through $0.4 \mu\text{m}$ filters. The iron hydroxide coprecipitates were dissolved in 6 M distilled hydrochloric acid and analysed by flameless atomic absorption. The limit of detection of this method is about $0.1 - 0.2 \text{ nmol/l}$. Precision is about 5%.

Mullins [189] has described a procedure for determining the concentrations of dissolved chromium species in seawater. Chromium (III) and chromium (VI) separated by coprecipitation with hydrated iron (III) oxide and total dissolved chromium are determined separately by conversion to chromium (VI), extraction with ammonium pyrrolidine diethyl dithiocarbamate into methyl isobutyl ketone, and determination by atomic absorption spectroscopy. The detection limit is 40 ng/l Cr . The dissolved chromium not amenable to separation and direct extraction is calculated by difference. In the waters investigated, total concentrations were relatively high, ($1 - 5 \mu\text{g/l}$), with chromium (VI) the predominant species in all areas sampled with one exception, where organically bound chromium was the major species.

A standard contact time of 4 h was found to be necessary for the quantitative coprecipitation of chromium on ferric oxide. The results of triplicate determinations of samples taken from six locations in the Sydney area are listed in Table 5.3. The rsd values for the determinations of chromium (III), chromium (VI), and total dissolved chromium were generally 10.0%, 5.0%, and 5.0% respectively.

From these results, the rsd for the calculated concentration of the bound species was 20%.

X-ray Fluorescence Spectrometry

Ahern et al. [195] have discussed the speciation of chromium in seawater. The method used coprecipitation of trivalent and hexavalent chromium, separately, from samples of surface seawater, and determination of the chromium in the

precipitates and particulate matter by thin-film X-ray fluorescence spectrometry. An ultraviolet irradiation procedure was used to release bound metal. The ratios of labile trivalent chromium to total chromium were in the range 0.4–0.5, and the totals of labile tri- and hexavalent chromium were in the range 0.3–0.6 $\mu\text{g/l}$. Bound chromium ranged from 0 to 3 $\mu\text{g/l}$, and represented 0–90% of total dissolved chromium. Acidification of the samples in the usual manner for the determination of trace metals altered the proportion of trivalent to hexavalent chromium.

High-Performance Liquid Chromatography – Mass Spectrometry

Parts per billion concentrations of chromium (III) and chromium (VI) in seawater have been determined using high-performance liquid chromatography in conjunction with inductively coupled plasma mass spectrometry [196].

5.15.4

Chromium (III) and Total Chromium. Gas Chromatography

Mugo and Orlans [197] have discussed shipboard methods for the determination of chromium (III) and total chromium in seawater by derivatisation with trifluoroacetylacetone followed by gas chromatography using an electron capture detector.

5.15.5

Organic Forms of Chromium

In the determination of the two oxidation states of chromium, the calculation of one oxidation state by difference presupposes that the two oxidation states in question were statistically the only contributors to the total concentration. Because of this, contributions from other possible species such as organic complexes were generally not considered. It has been suggested [198] however, that this presumption may not be warranted, and that contributions from organically bound chromium should be considered. This arises from the reported presence of dissolved organic species in natural waters, which form stable soluble complexes with chromium, and which may not be readily amenable to determination by procedures commonly in use. The results of research into the valency of chromium present in seawater has not always been consistent. For instance, Grimaud and Michard [199] reported that chromium (III) predominates in the equatorial region of the Pacific Ocean, whereas Cranston and Murray [171] found that practically all chromium is in the hexavalent state in the northeast Pacific. Organic Cr^{III} complexes may be formed under the conditions prevailing in seawater as well as inorganic Cr^{III} and Cr^{VI} forms. Inconsistencies in earlier research may therefore be at least partly due to the fact that the possibility of organic chromium species was ignored [198, 200].

Nakayama et al. [201] have described a method for the determination of chromium (III), chromium (VI), and organically bound chromium in seawater.

They found that seawater in the Sea of Japan contained about 9×10^{-9} M dissolved chromium. This is shown to be apportioned to about 15% inorganic Cr^{III} , about 25% inorganic Cr^{VI} , and about 60% organically bound chromium.

These workers studied the coprecipitation behaviours of chromium species with hydrated iron III and bismuth oxides.

The collection behaviour of chromium species was examined as follows. Seawater (400 ml) spiked with 10^{-8} M Cr^{III} , Cr^{VI} , and Cr^{III} organic complexes labelled with ^{51}Cr was adjusted to the desired pH by hydrochloric acid or sodium hydroxide. An appropriate amount of hydrated iron (III) or bismuth oxide was added; the oxide precipitates were prepared separately and washed thoroughly with distilled water before use [200]. After about 24 h, the samples were filtered on $0.4 \mu\text{m}$ nucleopore filters. The separated precipitates were dissolved with hydrochloric acid, and the solutions thus obtained were used for γ -activity measurements. In the examination of solvent extraction, chromium was measured by using ^{51}Cr , while iron and bismuth were measured by electrothermal atomic absorption spectrometry. The decomposition of organic complexes and other procedures were also examined by electrothermal atomic absorption spectrometry.

Collection of Cr^{III} and Cr^{VI} with Hydrated Iron^{III} or Bismuth Oxide

Only Cr^{III} coprecipitates quantitatively with hydrated iron (III) oxide at the pH of seawater, around 8. To collect Cr^{VI} directly without pretreatment, e.g., reduction to Cr^{III} , hydrated bismuth oxide, which forms an insoluble compound with Cr^{VI} , was used. Cr^{III} is collected with hydrated bismuth oxide (50 mg 400 ml^{-1} seawater). To collect Cr^{VI} in seawater a pH of about 4 was used. Both Cr^{III} and Cr^{VI} are thus collected quantitatively at the pH of seawater, around 8.

Collection of Cr^{III} Organic Complexes with Hydrated Iron (III) or Bismuth Oxide

The percentage collection of Cr^{III} with hydrated iron (III) oxide may decrease considerably in the neutral pH range when organic materials capable of combining with Cr^{III} , such as citric acid and certain amino acids, are added to the seawater [211]. Moreover, synthesised organic Cr^{III} complexes are scarcely collected with hydrated iron (III) oxide over a wide pH range [142].

As it was not known what kind of organic matter acts as the major ligand for chromium in seawater, Nakayama et al. [201] used EDTA and 8-quinolinol-5-sulfonic acid to examine the collection and decomposition of organic chromium species, because these ligands form quite stable water-soluble complexes with Cr^{III} , although they are not actually present in seawater. Both these Cr^{III}

chelates are stable in seawater at pH 8.1, and are hardly collected with either of the hydrated oxides. The organic chromium species were then decomposed to inorganic chromium (III) and chromium (VI) species by boiling with 1 g ammonium persulfate per 400 ml⁻¹ seawater acidified to 0.1 M with hydrochloric acid. Iron and bismuth, which would interfere in atomic absorption spectrometry, were 99.9% removed by extraction from 2 M hydrochloric acid solution with a *p*-xylene solution of 5% tri-iso-octylamine. Cr^{III} remained almost quantitatively in the aqueous phase in the concentration range 10⁻⁹–10⁻⁶ M, whether or not iron or bismuth was present. However, as about 95% of Cr^{VI} was extracted by the same method, samples which may contain Cr^{VI} should be treated with ascorbic acid before extraction so as to reduce Cr^{VI} to Cr^{III}.

When the residue obtained by the evaporation of the aqueous phase after the extraction was dissolved in 0.1 M nitric acid and the resulting solution was used for electrothermal atomic absorption spectroscopy, a negative interference was observed, seemingly due to organic matter. This interference was successfully removed by digesting the residue on a hot plate with 1 ml of concentrated hydrochloric acid and 3 ml of concentrated nitric acid. This process had the advantage that the interference of chloride in the atomic absorption spectroscopy was eliminated during the heating with nitric acid.

Typically, seawater samples taken in the Sea of Japan and Pacific Ocean contained 1–1.8 × 10⁻⁹ M chromium (III), 1.7–4.5 × 10⁻⁹ M chromium (VI), 3.5–6.2 × 10⁻⁹ M organic chromium, and 7.1–11.7 × 10⁻⁹ M total chromium.

Ishibashi and Shigematsu [202] used coprecipitation with aluminium hydroxide and did not employ reduction, so that the value reported most likely corresponds to inorganic Cr^{III} alone; in fact, the present value for inorganic Cr^{III} is in remarkable agreement.

In Chuecas and Riley's study [203] the samples were stored for a long time under acidic conditions before analysis, so that Cr^{VI} could have been reduced to Cr^{III} and any organic chromium dissociated, with the result that all chromium species would have been determined as Cr^{III}. When a sample is reduced under acidic conditions, organic chromium is likely to dissociate partly, initially increasing the apparent concentration of Cr^{VI}. When the analytical procedure of Kuwamoto and Murai [206] was re-examined, the value for Cr^{III} was found actually to be the sum of Cr^{III} and Cr^{VI}, while the value for Cr^{VI} was partly organic chromium. For the same reason, the Cr^{VI} values determined by Fukai [204], Fukai and Vas [205], and Yamamoto et al. [201] probably include organic chromium species. When an iron (II) precipitate is used, there seems to be little chance of determining the organic chromium species as Cr^{VI}. The value for Cr^{VI} reported by Cranston and Murray [171] agrees quite well with the value for Cr^{VI} reported by them, although the value for Cr^{III} is lower. The results obtained by Grimaud and Michard [199] for Cr^{III} differ considerably, but the discrepancies cannot be discussed because details of the analytical procedure were not given. It seems reasonable to conclude that the inconsistency of past results concerning the dominant chromium species

and the total chromium concentration in seawater can be attributed, at least in part, to the fact that the presence of organic chromium species was not considered properly.

See also Sects. 5.74.5, 5.74.6, 5.74.8–5.74.12, and 5.74.14–5.74.16.

5.16 Cobalt

Little is known of the oceanic distribution or speciation of cobalt, because very low concentrations (< 200 pM) make its determination difficult. Laboratory studies indicate that cobalt exists in seawater primarily as the cobalt (II) ion and as the carbonate complex. Organic complexes are not considered important.

The oceanic distribution of cobalt is similar to that of manganese, although cobalt concentrations are 10–100 times smaller; maximum concentrations are 100–300 pM in surface waters, decreasing to 10 pM at depths below 1000 m. As concentrations of cobalt in seawater are so low, it may become biolimiting in open ocean surface waters.

Because cobalt is an essential element in biological compounds like vitamin B₁₂ and some metalloproteins [208,209], the low concentration of this metal in seawater points to the possible role of cobalt as a biolimiting nutrient [210,211]. The discharge of various cobalt radionuclides from nuclear installations to coastal waters and their accumulation by marine organisms [212–214] has also increased interest in the fate of this element. Dissolved cobalt occurs in seawater at concentrations ranging from 0.01 to 0.2 nM [210,211]. Calculation of the organic complexation of cobalt using an ion pairing model and stability constants valid for seawater [215] shows that it is weakly complexed by inorganic ligands, the predominant inorganic species being cobalt (II) and as chloride complexes. There is some evidence that cobalt in seawater occurs strongly complexed by organic ligands [216,217]. The available data on cobalt distribution in seawater [210,218–220] show surface minima, a maximum within the upper thermocline as a result of atmospheric input, and depletion at depth due to removal from seawater, probably in association with MnO [221,222].

5.16.1 Spectrophotometric Methods

Various methods have been proposed for the determination of traces of cobalt in seawater and brines, most necessitating preconcentration. Solvent extraction followed by spectrophotometric measurements [223–230] is the most popular method but has many sources of error; the big difference in the volumes of the two phases results in mixing difficulties, and the solubility of the organic solvent in the aqueous phase changes the volume of organic phase, resulting in decreased reproducibility of the measurements. In many cases, excess of

reagent and various metal complexes are co-extracted with cobalt and cause errors in determining the absorbance of the cobalt complex.

The procedure of Kentner and Zeitlin [223] is as follows: to a filtered 750 ml sample of seawater add 20% aqueous sodium citrate (25 ml), 30% aqueous hydrogen peroxide (1 ml), and 1% ethanolic 1-nitroso-2-naphthol (treated with activated charcoal and filtered) (1 ml), and set aside for 10 min. Extract the cobalt complex into chloroform and back-extract the excess of reagent into basic wash solution (mix 1 M sodium hydroxide (50 ml), 20% aqueous sodium citrate (10 ml), and 30% aqueous hydrogen peroxide (1 ml) with water to produce 100 ml (3×5 ml extractions), shaking for 60 s for each extraction). Extract copper and nickel from the organic phase into 2 M hydrochloric acid (5 ml), back-extract any released reagent into basic wash solution (5 ml), and wash the chloroform phase again with 2 M hydrochloric acid (5 ml). Dilute the organic phase to 50 ml (for 30 ml cells) or 30 ml (for 20 ml cells) and measure the extinction at 410 nm against a blank in 10 cm cells.

In another spectrophotometric procedure Motomizu [224] adds to the sample (2 litres) 40% (w/v) sodium citrate dihydrate solution (10 ml) and a 0.2% solution of 2-ethylamino-5-nitrosophenol in 0.01 M hydrochloric acid (20 ml). After 30 min, add 10% aqueous EDTA (10 ml) and 1,2-dichloroethane (20 ml), mechanically shake the mixture for 10 minutes, separate the organic phase and wash it successively with hydrochloric acid (1:2) (3×5 ml), potassium hydroxide (5 ml), and hydrochloric acid (1:2) (5 ml). Filter, and measure the extinction at 462 nm in a 50 mm cell. Determine the reagent blank by adding EDTA solution before the citrate solution. The sample is either set aside for about 1 day before analysis (the organic extract should then be centrifuged), or preferably it is passed through a 0.45 μm membrane-filter. The optimum pH range for samples is 5.5–7.5. From 0.07 to 0.12 $\mu\text{g/l}$ of cobalt was determined; there is no interference from species commonly present in seawater.

Kouimtzis et al. [232] described a spectrophotometric method for down to $\mu\text{g/l}$ cobalt in seawater, in which the cobalt is extracted with 2,2'-dipyridyl-2-pyridylhydrazone (DPPH) [233,235–238], the cobalt complex is back-extracted into 20% perchloric acid, and this solution is evaluated spectrophotometrically at 500 nm. This avoids many of the sources of error that occur in earlier procedures.

Isshiki and Nakayama [234] have discussed the selective concentration of cobalt in seawater by complexation with various ligands or sorption on macroporous XAD resins. Complexed cobalt is collected after passage through a small XAD resin-packed column.

5.16.2

Atomic Absorption Spectrometry

Analytical procedures for the determination of cobalt in seawater generally use graphite furnace absorption spectrometry after a preconcentration step

involving solvent extraction, coprecipitation, or ion exchange on Chelex 100 resin [239]. These techniques have difficulties achieving the sensitivity required for the determination of the low levels of cobalt in seawater, and include a high risk of sample contamination and loss of analyte during the several sample preparation steps involved.

5.16.3

Flow Injection Analysis

Malahoff et al. [240] used a shipboard flow injection spectrophotometric technique to determine ppt concentrations of cobalt in seawater

5.16.4

Atomic Fluorescence Spectrometry

Yuzefovsky et al. [241] used C₁₈ resin to preconcentrate cobalt from seawater prior to determination at the ppt level by laser-excited atomic fluorescence spectrometry with graphite electrothermal atomiser.

5.16.5

Spectrofluorometry

To determine cobalt in seawater, Boyle [242] solvent-extracted the cobalt using Luminol, with which 5 pmol kg⁻¹ of cobalt can be determined.

5.16.6

Chemical Luminescence Analysis

Sakamoto [243] determined picomolar levels of cobalt in seawater by flow injection analysis with chemiluminescence detection. In this method flow injection analysis was used to automate the determination of cobalt in seawater by the cobalt-enhanced chemiluminescence oxidation of gallic acid in alkaline hydrogen peroxide. A preconcentration/separation step in the flow injection analysis manifold with an in-line column of immobilised 8-hydroxyquinoline was included to separate the cobalt from alkaline-earth ions. One sample analysis takes 8 min, including the 4-min sample load period. The detection limit is approximately 8 pM. The average standard deviation of replicate analyses at sea of 80 samples was $\pm 5\%$. The method was tested and intercalibrated on samples collected off the California coast.

Cobalt (II) has been determined by online measurements on seawater which has been passed through a column containing 8-quinolinol immobilised on silica gel, followed by chemical luminescence detection [244].

5.16.7

Cathodic Stripping Voltammetry

Adsorptive cathodic stripping voltammetry has an advantage over graphite furnace atomic absorption spectrometry in that the metal preconcentration is performed *in situ*, hence reducing analysis time and risk of contamination. Additional advantages are low cost of instrumentation and maintenance, and the possibility to use adapted instrumentation for online and shipboard monitoring.

Vega and Van den Berg [245] have described a procedure for the direct determination of picomolar levels of cobalt in seawater. Cathodic stripping voltammetry is preceded by adsorptive accumulation of the cobalt–nioxime (cyclohexane-1,2-dione dioxime) complex from seawater containing 6 μM nioxime and 80 mM ammonia at pH 9.1 onto a hanging mercury-drop electrode, followed by reduction of the adsorbed species. The reduction current is catalytically enhanced by the presence of 0.5 M nitrite. Optimised conditions for cobalt include a 30 s adsorption period at -0.7 V and a voltammetric scan using differential pulse modulation. According to the proposed reaction mechanism, dissolved cobalt (II) is oxidised to cobalt (III) upon addition of nioxime and high concentrations of ammonia and nitrite; a mixed cobalt (III)–ammonia–nitrite complex is adsorbed on the electrode surface; the cobalt (III) is reduced to cobalt (II) (complexed by nioxime) during the voltammetric scan, followed by its chemical reoxidation by the nitrite, initiating a catalytically enhanced current. A detection limit of 3 pM cobalt (at an adsorption period of 60 s) enables the detection of this metal in uncontaminated seawater using a very short adsorption time. UV digestion of seawater is essential, as part of the cobalt may occur strongly complexed by organic matter and rendered nonlabile. The method was applied successfully to the determination of the distribution of cobalt in the water column of the Mediterranean.

See also Sects. 5.74.4–5.74.6 and 5.74.8–5.74.16.

5.16.8

Polarography

Harvey and Dutton [231] determined nanogram amounts of cobalt in seawater after concentration on manganese dioxide formed by photochemical oxidation of divalent manganese in a photochemical reactor. The sample (1 litre) containing 100 μg manganese was irradiated in an Hanovia reactor fitted with a 2 W low-pressure Hg discharge lamp radiating mainly at 254 and 185 nm. The manganese dioxide deposit that adhered to the silica jacket of the reactor was dissolved in 0.15 M hydrochloric acid containing a trace of sulfur dioxide, the solution was evaporated to dryness, and the residue was dissolved in 4 ml of 0.625 M hydrochloric acid; 1 ml 5 M aqueous ammonia and 0.1 ml of 0.1% dimethylglyoxime in ethanol were added, and cobalt was determined by pulse

polarography. The polarograph was operated in the derivative mode, starting at -1.0 V, and a 50 mV pulse height and 1 s mercury drop life were used.

5.17

Copper

Copper (II) is present in natural waters in a variety of chemical forms. Sylva [246] indicated that the following species are found in freshwater systems: Cu^{2+} ; CuCO_3 ; $\text{Cu}(\text{CO}_3)_2^{2-}$; CuHCO_3^+ ; CuOH^+ ; $\text{Cu}_2(\text{OH})_2^{2+}$; CuCl^+ . It was also found that Cu^{2+} can be removed completely from aquatic systems by precipitation as $\text{Cu}(\text{OH})_2$, CuCO_3 , and $\text{Cu}(\text{OH})_n(\text{CO}_3)_{1-n/2}$.

Sunda and Hanson [247] have used ligand competition techniques for the analysis of free copper (II) in seawater. This work demonstrated that only 0.02–2% of dissolved copper (II) is accounted for by inorganic species. (i.e., Cu^{2+} , CuCO_3 , $\text{Cu}(\text{OH})^+$, CuCl^+ , etc.); the remainder is associated with organic complexes. Clearly, the speciation of copper (II) in seawater is markedly different from that in fresh water.

Importantly, Sunda and coworkers [248, 249] demonstrated that free copper (II) – not total copper – is responsible for copper (II) toxicity. Consequently, the impact of copper (II) on the marine environment can be ascertained only by measurement of free copper (II) levels.

The importance of complexing agents in the mineral nutrition of phytoplankton and other marine organisms has been recognised for more than 20 years. Complexing agents have been held responsible for the solubilisation of iron, and therefore its greater biological availability [250]. In contrast, complexing agents are assumed to reduce the biological availability of copper and minimise its toxic effect [251–264]. Experiments with pure cultures of phytoplankton in chemically defined media have demonstrated that copper toxicity is directly correlated with cupric ion activity and independent of the total copper concentration. In these experiments, cupric ion (Cu^{2+}) concentrations were varied in media containing a wide range of total concentrations through the use of artificial complexing agents. When Cu^{2+} concentration was calculated for earlier experiments with phytoplankton in defined media, it appeared that Cu^{2+} was toxic to a number of phytoplankton species in concentrations as low as $10^{-6} \mu\text{mol}^{-1}$ [260]. Since copper concentrations in the world ocean typically range from 10^{-4} to $10^{-1} \mu\text{mol}^{-1}$, complexing agents and other materials affecting the solution chemistry of copper must maintain the Cu^{2+} activity at sublethal levels.

Copper may exist in particulate, colloidal, and dissolved forms in seawater. In the absence of organic ligands, or particulate and colloidal species, carbonate and hydroxide complexes account for more than 98% of the inorganic copper in seawater [285, 286]. The Cu^{2+} concentration can be calculated if pH, ionic strength, and the necessary stability constants are known [215, 265–267]. In most natural systems, the presence of organic materials and sorptive surfaces

significantly alters speciation and decreases the utility of equilibrium calculations. Analytical difficulties in the measurement of Cu^{2+} and copper associated with naturally occurring ligands has encouraged numerous workers to introduce the “complexation capacity” concept [268–270]. Functionally, the copper complexing capacity of a water sample is the ability of the sample to remove added copper from the free ion pool [271]. Analytically, complexation capacity measurements depend on quantitation complexing ability of an operationally defined group of ligands. The assumption is made that unknown ligands may be classed into meaningful groups on the basis of the physical properties of their metallo-complexes, (e.g., lability to anodic stripping voltammetry (ASV), chelating resins, or ultraviolet radiation). Schemes to determine the concentration of copper associated with different classes have been proposed as useful ways to address complexing capacity questions in natural systems [272,273], as have various titrimetric techniques [274,275]. Different analytical procedures measure the copper chelating capacity of slightly different classes of ligands, and there is some overlap in the complexes included in classes defined by different techniques. For example, while there is a small fraction of organic material in seawater which forms ASV-labile complexes not dissociated by Chelex resin [276], most AVS-labile complexes are also labile to chelating resins [277].

5.17.1

Titration Procedures

Ruzic [278] considered the theoretical aspects of the direct titration of copper in seawaters and the information this technique provides regarding copper speciation. The method is based on a graph of the ratio between the free and bound metal concentration versus the free metal concentration. The application of this method, which is based on a 1:1 complex formation model, is discussed with respect to trace metal speciation in natural waters. Procedures for interpretation of experimental results are proposed for those cases in which two types of complexes with different conditional stability constants are formed, or on which the metal is adsorbed on colloidal particles. The advantages of the method in comparison with earlier methods are presented theoretically and illustrated with some experiments on copper (II) in seawater. The limitations of the method are also discussed.

Waite and Morel [279] have described an amperometric titration procedure for the characterisation of organic copper complexing ligands, and applied it to a variety of synthetic and naturally occurring organic compounds. The procedure is based upon the ability, in solutions of high chloride content, to obtain a sensitive and reproducible amperometric measurement of reducible copper (II) at positive voltages up to about 100 mV relative to an Ag/AgCl reference electrode. Copper (II) is reduced to copper (I), which is stabilised by chloride despite the presence of oxygen. Application of the titration technique to a high chloride content electrolyte containing various concentrations of nitrilo-

triacetic acid confirms that copper–ligand reduction and dissociation are not major problems, provided that a sufficiently positive working electrode potential is chosen and that the concentration of the organic ligand is low. Application of the procedure to a variety of naturally occurring organic agents including a fulvic acid, fresh water algal exudates, and a sample of Sargasso seawater, produces results that are consistent with those found by alternative methods.

5.17.2

Atomic Absorption Spectrometry

Cabon and Le Bihan [280] studied signals obtained by electrothermal atomic absorption spectrometry of seawater matrices. The interference effect of sodium chloride, sodium nitrate, sodium sulfate, magnesium chloride, and calcium chloride on the electrothermal atomic absorption spectrometric signal of copper in seawater were studied. Thermal treatment at 600–800 °C caused hydrolysis of magnesium chloride to magnesium oxide and minimised its interference. Ashing at higher temperatures of 1300, 1200, and 1100 °C was carried out in the presence of sulfate, nitrate, and chloride salts, respectively, without loss of copper. A study of the influence of two-component, chloride–nitrate or chloride–sulfate matrices illustrated the stabilising effect of the formation of metal oxides and metal sulfides on the copper signal. This stabilisation enhanced the decrease in interference connected with chloride removal in an acidic medium.

In further work Cabon [281] proposed a model to describe the variations in copper signals caused by the principal inorganic ions in seawater (sodium, magnesium, calcium, chloride, and sulfate). Data obtained by ashing simulated seawaters under different temperature conditions were used. Ashing at 800 °C caused hydrolysis of magnesium chloride to magnesium oxide and the formation of sodium sulfide. Both of these products enhanced the stability of copper in the furnace. A complementary decrease in interference occurred in the presence of magnesium when a small amount of nitrate (0.2 M) was added. The model was confirmed by results obtained using nitric or sulfuric acid as modifier.

To determine down to 2.4 µmol/l of copper in seawater, Nishoika et al. [282] complexed the copper with di-ethyl-dithio carbamate, precipitated with ferric hydroxide, filtered off and dissolved the precipitate with nitric acid, and determined copper by electrothermal atomic absorption spectrometry.

Muzzarelli and Rocchetti [287] showed that chitosan is superior to Dowex A700 ion exchange resin and modified celluloses for the collection of copper from unoxidised seawater. In this procedure, the sample is passed through a column (30 × 3 mm) packed with chitosan (100 mg; 100–200 mesh), and the chelated copper eluted with a 1% solution of 1,10-phenanthroline (20 ml) at 50 °C or with 1 M sulfuric acid (20 ml). Place an aliquot (20 µl) in a hot graphite analyser programmed to dry for 20 s, char for 20 s and atomise for 10 s. Determine the amount of copper present by comparison with standards.

Average recoveries from the column were 100%, and the coefficient of variation was 7.5% for 3.4 μg of copper per litre.

5.17.3

Spectrophotometric Method and Spectrofluorometric Method

Abraham et al. [286] determined total copper in seawater spectrophotometrically using quinaldehyde 2-quinolyl-hydrazone as chromogenic reagent. This method is capable of determining copper at the ppb level.

Hui-Hui Zeng et al. have described a real-time determination of free copper (II) in seawater using a fluorescence-based fibre optic method [946].

A C_{18} column loaded with sodium diethyldithiocarbamate has been used to extract copper and cadmium from seawater. Detection limits for analysis by graphite furnace atomic absorption spectrometry were 0.024 $\mu\text{g/l}$ and 0.004 $\mu\text{g/l}$, respectively [283].

5.17.4

Ion-Selective Electrodes

Ion-selective electrodes have been used for the potentiometric determination of the total cupric ion content of seawater [284]. Down to 2 $\mu\text{g/l}$ cupric copper could be determined by this procedure.

De Marco [285] evaluated three different types of copper (II) ion-selective electrodes. The copper sulfide electrode was found to be oxidised, whereas the copper selenide and copper sulfide electrodes were found to have chloride ion interference at copper (II) activities exceeding 10^{-8} M.

Prior to the introduction of ion-selective electrode techniques, in situ monitoring of free copper (II) in seawater was not possible due to the practical limitations of existing techniques (e.g., ligand competition and bacterial reactions). Ex situ analysis of free copper (II) is prone to experimental error, as the removal of seawater from the ocean can lead to speciation of copper (II). Potentially, a copper (II) ion electrode is capable of rapid in situ monitoring of environmental free copper (II). Unfortunately, copper (II) has not been used widely for the analysis of seawater due to chloride interference that is alleged to render the copper nonfunctional in this matrix [288].

Westall et al. [289] and Lewenstam et al. [290] proposed a layer mechanism to account for the chloride interference in the CuS electrode.

5.17.5

Electroanalytical Methods

Cathodic stripping voltammetry has been used to determine copper species in seawater [291, 292].

In one method [292], a reduction current occurred when a solution of catechol and copper was subjected to cathodic stripping voltammetry at a hanging mercury drop electrode. The composition of the adsorbed film and the optimal conditions for its formation were investigated. The phenomenon was used to determine copper in seawater using ac polarography to measure complex adsorption. Currents were detected at the very low copper concentrations that occurred in uncontaminated seawater. Competition for copper ions by natural organic complexing ligands was evident at low concentrations of catechol. The method was more sensitive and had a shorter collection period than the rotating-disk electrode DPASV technique, with comparable accuracy.

Scorano et al. [293] determined copper at the 5×10^{-10} M level in seawater by anodic stripping voltammetry using ethylenediamine. These workers investigated the properties of ethylenediamine (en) as a means of performing the analysis of ligand-exchangeable and labile (i.e., directly reducible at pH 8) copper in seawater at trace levels. Stripping polarographic or pseudopolarographic determinations show that the copper ethylenediamine complex behaves reversibly in seawater, exchanging two electrons at the mercury drop electrode.

The role of chloride ions in competitive reactions with ethylenediamine for copper during the stripping step was also studied. In seawater made 2×10^{-3} M in ethylenediamine, copper (II) can be detected at the hanging mercury drop electrode by differential pulse anodic stripping voltammetry at the 5×10^{-10} M level, with a deposition time of 10 min. A procedure for measuring pH 8 labile copper in seawater is obtained by coupling differential pulse anodic stripping voltammetry with a medium alteration method. Addition of ethylenediamine at the end of the electrolysis more than doubles peak height by doubling the current yield per mole of copper and by removing interferences associated with the oxidation of copper in chloride media. This procedure facilitates the voltammetric study of copper in seawater under natural conditions.

Quentel et al. [294] complexed copper with 1,2-dihydroxyanthraquinone-3 sulfuric acid prior to determination by absorptive stripping voltammetry in amounts down to 0.3 nM in seawater.

Wang et al. [295] used a remote electrode, operated in the potentiometric stripping mode, for the continuous onboard measurement of copper distribution patterns in San Diego Bay (CA, USA).

Garcia-Monco Carrá et al. [296] have described a "hybrid" mercury film electrode for the voltammetric analysis of copper (and lead) in acidified seawater. Mercury plating conditions for preparing a consistently reproducible mercury film electrode on a glassy carbon substrate in acid media are evaluated. It is found that a "hybrid electrode", i.e., one preplated with mercury and then replated with mercury *in situ* with the sample, gives very reproducible results in the analysis of copper in seawater. Consistently reproducible electrode performance allows for the calculation of a cell constant and prediction of the slopes of standard addition plots, useful parameters in the study of copper speciation in seawater.

A hanging mercury drop electrodeposition technique has been used [297] for a carbon filament flameless atomic absorption spectrometric method for the determination of copper in seawater. In this method, copper is transferred to the mercury drop in a simple three-electrode cell (including a counter-electrode) by electrolysis for 30 min at -0.35 V versus the SCE. After electrolysis, the drop is rinsed and transferred directly to a prepositioned water-cooled carbon-filament atomiser, and the mercury is volatilised by heating the filament to 425°C . Copper is then atomised and determined by atomic absorption. The detection limit is 0.2 μg copper per litre simulated seawater.

5.17.6

Isotope Dilution Methods

Isotope dilution mass spectrometry has been used to determine traces of copper in seawater [298,299].

5.17.7

Electron Spin Resonance Spectrometry

Background copper levels in seawater have been measured by electron spin resonance techniques [300]. The copper was extracted from the seawater into a solution of 8-hydroxyquinoline in ethyl propionate (3 ml extractant per 100 ml seawater), and the organic phase (1 ml) was introduced into the electron spin resonance tube for analysis. Signal-to-noise ratio was very good for the four-line spectrum of the sample and of the sample spiked with 4 and 8 ng Cu^{2+} . The graph of signal intensity versus concentration of copper was rectilinear over the range 2–10 $\mu\text{g}/\text{l}$ of seawater, and the coefficient of variation was 3%.

5.17.8

Miscellaneous Methods

Traces of copper and lead are separated [301] from macro amounts of calcium, magnesium, sodium, and potassium by adsorption from the sample onto active carbon modified with hydroxyquinoline dithizone or diethyldithiocarbamate.

Marvin et al. [302] have discussed the effects of sample filtration on the determination of copper in seawater, and concluded that glass filters could seriously affect the reliability of subsequent analysis.

5.17.9

Copper Speciation

Wood et al. [303] have described an ion exchange technique for the measurement of the copper complexing capacity of seawater samples taken in the

Sargasso Sea, and continental shelf samples. This technique measures the copper complexing capacity of relatively strong dissolved and colloidal organic complexing agents in natural seawater. The technique was used to compare the copper complexing capacity of strong organic dissolved and colloidal complexing agents in those samples. They also determined the relationship between the copper complexing capacity of a specific group of complexing agents and the concentration of two large heterogeneous pools of potential complexing agents; dissolved organic carbon and total particulate material. The copper complexing capacity of these samples ranged from 0.014 to 1.681 $\mu\text{mol Cu}$ per litre on the inner shelf, from 0.043 to 0.095 mol Cu per litre in mid- and outer-shelf waters, and from 0.010 to 0.036 $\mu\text{mol Cu}$ per litre at the Sargasso Sea stations.

The ion exchange procedure used by Wood et al. [303] to estimate copper complexation capacity was a modification of that used by Stolzberg and Rosin [304] and Giesy [305]. Excess Cu^{2+} is added to the filtered samples and allowed to equilibrate with available ligands. Each sample is then passed through a column packed with Nalohex resin (Biorad 100–200 mesh), and Cu^{2+} and Cu associated with weak or rapidly dissociating complexes are removed by the resin; Cu remaining in the sample after chromatography provides a quantitative measure of the Cu-chelating capacity of strong ligands remaining in the sample. The procedure has the advantage that complex formation proceeds at seawater pH in a relatively undisturbed sample. However, the procedure also depends on the assumption that essentially all the Cu ligands (L^{n-}) in the sample are associated with Cu.

This involves the reaction

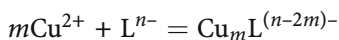

All chromatography was conducted at flow rates greater than 20 ml $\text{cm}^{-2} \text{s}^{-1}$, since slower flow rates resulted in complex dissociation.

The concentration of copper in the column eluent was determined by flame atomic absorption spectroscopy of samples which were preconcentrated with ammonium pyrrolidine dithiocarbamate (APDC) and methyl isobutyl ketone. The pH of the acidified sample was adjusted to pH 2.5–3.5 using 400 μl 8 M ammonium acetate (Chelex cleaned).

Zorkin et al. [306] developed a procedure to estimate the amount of biologically active copper in seawater based on the assumption that the divalent copper ion was the most toxic species, and its concentration could be related to the amount of metal sorbed on a sulfuric-acid cation exchange resin. The method was tested by application to artificial seawater containing copper and the organic ligands EDTA, NTA, histidine, and glutamic acid. Other experiments showed there was a correlation between the inorganic copper fraction determined by the ion exchange procedure and the toxic fraction of copper quantified by a bioassay using the marine diatom.

In recent years much of the work concerned with the speciation of copper and other trace metals in natural waters has been done using anodic stripping voltammetry. This work has primarily progressed in two directions: studies of the shift in trace metal peak potentials with changing concentrations of ligands [307–311], and studies of changes in metal peak height or peak area under differing experimental conditions. Variants of the second approach include pH titrations [311–313] and compleximetric titrations [269], in which natural or added ligands are quantitatively titrated with metal ions, or alternatively metal ions are titrated with ligands [269, 270, 314]. In this technique, the electrolysis potential is set at a value which presumably discriminates between the “free” (i.e., rapidly reducible) metal and the complexed metal, which is reduced at a much slower rate. This approach has been used extensively to estimate the “complexation capacity” of natural waters.

Techniques based on the shift of the peak potential depend on the degree of reactivity of the oxidised metal with the ligand of interest in the reaction layer. They can describe the species undergoing reduction, i.e., the speciation in the natural medium, only indirectly and by assuming reversibility. Thus they are more suitable for model studies [265, 307] and for the determination of stability constants in known media [308, 309, 315] than for direct determination of natural speciation. On the other hand, methods dependent on peak height or peak area can give direct information on the natural species as long as a direct proportionality exists between the quantity of metal reduced during electrolysis and the metal oxidised from the amalgam. One relatively novel form of anodic stripping voltammetry which gives information about the species undergoing reduction is stripping polarography, sometimes called pseudopolarography [316–318].

In this technique, peak heights or peak areas obtained by anodic stripping voltammetry are plotted against the applied electrolysis potential. These plots have the sigmoidal shape of ordinary dc polarograms, but without the residual current component, and present the possibility of extending existing polarographic methodology to trace metals at the part per billion ($\mu\text{g/l}$) level. The shapes of the plots indicate the degree of reversibility of the species undergoing reduction and may be useful for their identification.

Zirino and Kounaves [319] applied this technique to a study of the reduction of copper in seawater. Figure 5.8 shows three plots of $6 \mu\text{g/l}$ copper added to unfiltered seawater from San Diego Bay (CA, USA), and analysed under varying conditions. Each of the experimental points represents the copper peak current obtained by anodic stripping voltammetry after 5 min electrolysis at a hanging mercury drop electrode. The plots obtained for copper at pH 8 (Figs. 5.8a and 5.8b) feature broadly curving slopes, and no distinct limiting plateau is reached, even at the highest applied potential. The shapes of these “waves” indicate an irreversible reduction. On the other hand, the reduction of copper at pH 3.0 is quasi-reversible, with $E_{3/4} - E_{1/4} = 42 \text{ mV}$ (Fig. 5.8c).

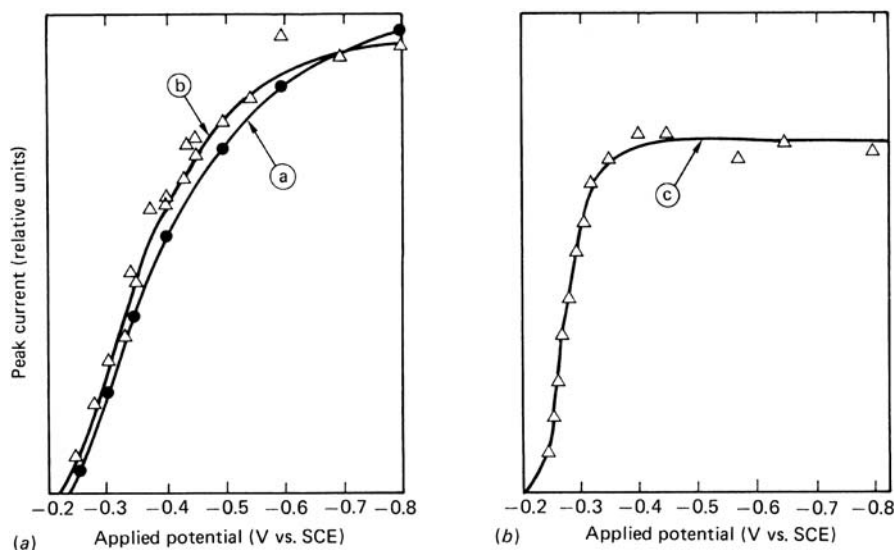

Figure 5.8. Stripping polarographic plots of 6 ppb Cu in seawater (not to scale). (a) Raw seawater, pH 8. (b) Ultraviolet-oxidised seawater, pH 8. (c) Raw seawater, pH 3. Source: [319]

Potentiometric stripping analysis has been applied by Sheffrin and Williams [320] to the measurement of copper in seawater at environmental pH. The advantage of this technique is that it can be used to specifically measure the biologically active labile copper species in seawater samples at desired pH values. The method was applied to seawater samples that had passed a 0.45 μm Millipore filter. Samples were studied both at high and at low pH values.

These workers used a radiometer ISS 820 ion-scanning system [101, 321–323] equipped with a glassy carbon electrode to determine copper at the 2–200 $\mu\text{g/l}$ level in nitrogen-purged 0.45 μm Millipore-filtered seawater to which had been added 5 ppm mercury.

The speciation of copper is different at high and low pH. At pH 1.0 most of the copper will be labile and a total copper concentration will be measured. At pH 7.7 there should be a smaller proportion of labile copper, as much will be complexed in various forms, depending on the constituents of the seawater.

Because of this complexation capacity, any standard addition performed at high pH will not return 100% of the spike, so a true value for the copper concentration cannot be calculated. Therefore, after an initial measurement at high pH the sample was acidified to pH 1.0 with 0.5 ml acid and another trace obtained. This compared the amount of copper released at low pH with the labile fraction at high pH. Standard additions were performed on the sample at low pH so almost all of the spike was returned. This allowed an estimate to be made of the percentage of total copper that was labile at high pH, and the quantification of this fraction in $\mu\text{g/l}$. This is illustrated graphically in Fig. 5.9.

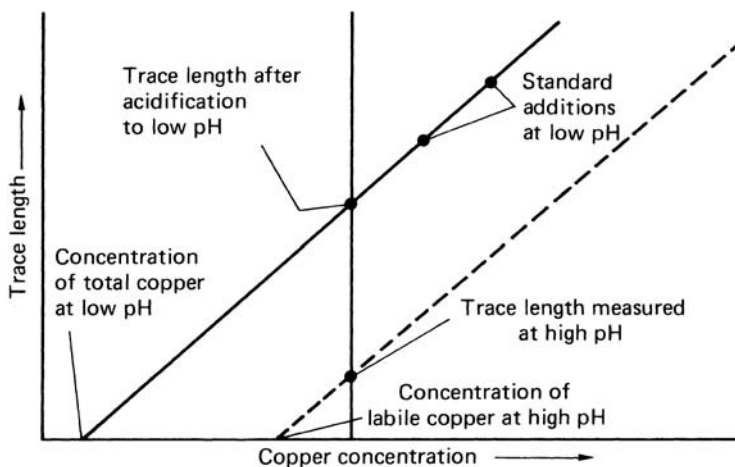

Figure 5.9. Measurements of labile copper at high pH. Source: Author's own files

The analysis of total copper by potentiometric stripping analysis depends on the way any bound copper is released; that is, whether the sample is acidified and to what pH, whether it is acidified and boiled, or treated with ultraviolet radiation and then acidified. Results obtained using these different methods are given in Table 5.4, which compares the analysis of a “poor-quality” sample, i.e., low-pH aquarium seawater, by potentiometric stripping analysis, and by atomic absorption spectrometry after extraction with ammonium tetramethylene-dithiocarbamate-isobutyl methyl ketone [324, 325], as well as a potentiometric stripping analysis of a “good-quality” sample, i.e., seawater of higher pH. The difference between the results for the “poor-quality” seawater analysed by the two techniques was not significant.

Shuman and Michael [326, 327] introduced a technique that has sufficient sensitivity for kinetic measurement at very dilute solutions. It combines anodic scanning voltammetry with the rotating-disk electrode and provides a method for measuring kinetic dissociation rates in situ, along with a method for distinguishing labile and non-labile complexes kinetically, consistent with the way they are defined.

Odier and Plichon [328] used ac polarography to determine the chemical form and concentration of copper in seawater. The shift of the $E_{1/2}$ of reduction of Cu^{II} determined by ac polarography serves to identify the inorganic complexes of copper and to determine their formation constants. They showed that copper is present in seawater mainly as Cu^{2+} , CuCl^+ , and $(\text{Cu}(\text{HCO}_3)_2(\text{OH}))^-$. Copper down to $3 \mu\text{g/l}$ was determined in seawater by ac polarography after acidifying to pH 5 by passage of carbon dioxide.

Turner et al. [331] studied the application of the automated electrochemical stripper to the determination of copper in seawater.

Table 5.4. Analysis of 'poor quality' seawater by potentiometric stripping analysis and atomic absorption spectroscopy and 'good quality' seawater by potentiometric stripping analysis

Analysis	Measured copper concentration (ppb)	pH	Sample treatment	Electrolysis voltage	Plating time (min)
Potentiometric stripping analysis of 'poor quality' seawater	8.3	1.7	Acidified	- 0.6	8
	8.6	1.1	Acidified	- 1.1	8
	6.8	1.7	Acidified	- 0.6	8
	9.6	1.7	Acidified	- 0.6	16
	8.6	1.3	Acidified and boiled (15 min)	- 0.6	32
	14.0	1.6	Acidified and boiled (15 min)	- 0.6	8
	15.8	1.6	Acidified and boiled (15 min)	- 0.6	8
	Mean (\pm SD) = 10.24 \pm 3.3				
AAS/ATDC - IBMK* analysis of 'poor quality' seawater.	35 sample: Mean (\pm SD) = 12.4 \pm 3.1				
	1.4	1.3	Acidified and boiled (15 min)	- 0.6	32
Potentiometric stripping analysis of 'good quality' seawater	2.2	0.9	Acidified	- 0.6	32
	8.6	1.3	Acidified	- 0.6	32
	0.36	7.0	Ultraviolet irradiation (67 min)	- 0.6	32

*: Ammonium tetramethylenedithiocarbamate - isobutyl methyl ketone
From Author's own files

Neutron activation analysis has been used [329] to determine total copper in seawater.

Cathodic stripping voltammetry has been used to determine copper species in seawater [291, 292]. Van den Berg [330] determined copper in seawater by cathodic stripping voltammetry of complexes with catechol.

A technique for the determination of free cupric ions in seawater has been described by Sunda and Hanson [332]. The method is based on sorption of copper onto Sep-Pak C₁₈ cartridges and internal free cupric ion calibration. Calibration is accomplished by adding cupric ion buffers and EDTA, which competes with natural organic ligands for copper complexation. The method was used to establish that 0-2% of the copper occurs as inorganic species and 98-100% occurs as organic complexes.

See also Sects. 5.74.4-5.74.6 and 5.74.8-5.74.16.

**5.18
Dysprosium**

See Sect. 5.49.

**5.19
Erbium**

See Sect. 5.49.

**5.20
Europium**

See Sects. 5.49 and 5.74.16.

**5.21
Gadolinium**

See Sect. 5.49.

**5.22
Gallium**

See Sect. 5.74.14.

**5.23
Germanium****5.23.1
Hydride Generation Furnace Atomic Absorption Spectrometry**

Andreae and Froelich [333] have described a procedure for the determination of germanium in seawater. In this method the peak absorbance was somewhat dependent upon atomisation temperature, rising sharply between 2400 and 2500 °C, and remaining almost constant above this temperature. As the lifetime of the tube decreases with the burn temperature, it was decided to use 2600 °C as the analysis temperature. The addition of a short high-temperature (2900 °C) burn cycle with full-purge gas flow preceding the analysis burn cycle improved the blank values and removed memory effects which were sometimes encountered when going from large to small analyte amounts. Under these conditions, tubes lasted for at least 100 determinations.

The sensitivity of this system is 430 pg/0.0044 absolute. The standard deviation of the baseline noise is about 0.0007 absolute, resulting in a noise-limited detection limit of 140 pg of germanium at the 95% confidence level.

See also Sect. 5.74.7.

5.24

Gold

5.24.1

Inductively Coupled Plasma Mass Spectrometry

Falkner and Edmond [334] determined gold at femtomolar quantities in seawater by flow injection inductively coupled plasma quadrupole mass spectrometry. The technique involves preconcentration by anion exchange of gold as a cyanide complex, $[\text{Au}(\text{CN})_2]^-$, using ^{195}Au radiotracer ($t_{1/2} = 183$ days) to monitor recoveries. Samples are then introduced by flow injection into an inductively coupled plasma quadrupole mass spectrometer for analysis. The method has a detection limit of ≈ 10 fM for 4 litres of seawater preconcentrated to 1 ml, and a relative precision of 15% at the 100 fM level.

5.24.2

Photometry

Pilipenko and Pavlova [335] determined traces of gold in seawater using a "spot" photometric method. This method is based on the catalysis (by AuCl_2SO_4) of the oxidation of Fe^{II} by Ag^{I} with production of metallic silver. The sample is filtered through paper, and the paper is dried and decomposed with sulfuric acid, nitric acid, hydrofluoric acid, water solution (1:1:1:1). The residue is dissolved in a few drops of *aqua regia*, this solution is evaporated, and the residue is dissolved in one drop of 0.05 M sulfuric acid. This solution is applied to filter paper, and to the resulting spot are applied drops of phosphate-citrate buffer solution (pH 2.4) of 0.72 M ferrous sulfate, in 0.05 M sulfuric acid and of 0.1 M silver nitrate; 15 s after the silver nitrate solution has been applied, the reflectance of the spot (due to metallic silver) is measured with a suitable instrument. The reflectance is proportional to the amount of gold on the paper, from 3 to 60 pg. As little as 0.0025 $\mu\text{g/l}$ of gold can be determined in seawater.

5.25

Holmium

See Sect. 5.49.

5.26

Indium

5.26.1

Neutron Activation Analysis

Matthews and Riley [336] determined indium in seawater at concentrations down to 1 ng/l. Preconcentration of metals on a cation exchanger was fol-

lowed by separation of alkali metals and alkaline-earth metals by retention of indium as a chloro-complex on an anion exchanger. Samples of indium containing eluate were then concentrated and irradiated in a thermal neutron flux of 5×10^{12} neutrons/cm²/s for several weeks, and the resulting 1.98 MeV β -radiation of the long-lived ^{114m}In daughter nuclide was counted. Minor elements were removed by a series of post-irradiation solvent-extraction stages.

See also Sects. 5.74.5, 5.74.8, and 5.74.9.

5.27

Iridium

See Sect. 5.74.5.

5.28

Iron

Worldwide, marine chemists and marine biologists have focused on the behaviour of iron in seawater, since Martin et al. [337–341] pointed out that the phytoplankton growth in oceanic water was limited by the deficiency of iron derived from the atmosphere, rather than the lack of nutrients in some oceanic regions, such as the equatorial Pacific, Gulf of Alaska, and Antarctic Ocean. This attractive hypothesis created a heated argument [291, 329–331, 342–345] and spurred the geochemical study of iron. For example, Zhuang et al. [346] reported recently that more than half of the iron in aeolian mineral dust existed in the form of iron (II), resulting in the enhancement of solubility of iron in surface water. In order to verify whether or not the iron deficiency contributes to the limitation of primary production and also to clarify the chemical species of iron, an accurate and rapid analytical method for determining iron seawater is essential.

5.28.1

Spectrophotometric Methods

Blain and Treguer [351] coupled a C₁₈ column impregnated with ferrozine, a selective ligand for iron (II), to a spectrometer for online determination of iron (II) in seawater in amounts down to 0.1 mM.

Shriadah and Ohzeki [350] determined iron in seawater by densitometry after enrichment as a bathophenanthroline disulfonate complex on a thin layer of anion exchange resin. Seawater samples (50 ml) containing iron (II) and iron (III) were diluted to 150 ml with water, followed by sequential addition of 20% hydrochloric acid (100 μ l), 10% hydroxyl-ammonium chloride (2 ml), 5 M ammonium solution (to pH 3.0 for iron (III) reduction), bathophenanthroline disulfonate solution (1.0 ml), and 10% sodium acetate solution (2.0 ml) to give a mixture with a final pH of 4.5. A macroreticular anion exchange resin in the

chloride form, Amberlyst A27, was added, the resultant coloured thin layer was scanned by a densitometer, and the absorbance measured at 550 nm.

5.28.2

Atomic Absorption Spectrometry

A conventional analytical method, like solvent extraction–graphite furnace atomic absorption spectrometric detection, requires a contamination-free technique. Moreover, it is time-consuming and troublesome, as litres of the sample solution must be treated because the dissolved concentration of iron in oceanic waters is extremely low ($1 \text{ nmol/l} = 56 \text{ ng/l}$). Martin et al. [341] recently found that the dissolved concentration of iron was less.

Atomic absorption spectrometry coupled with solvent extraction of iron complexes has been used to determine down to $0.5 \text{ }\mu\text{g/l}$ iron in seawater [354, 355]. Hiire [354] extracted iron as its 8-hydroxyquinoline complex. The sample is buffered to pH 3–6 and extracted with a 0.1% methyl isobutyl ketone solution of 8-hydroxyquinoline. The extraction is aspirated into an air-acetylene flame and evaluated at 248.3 nm.

Moore [355] used the solvent extraction procedure of Danielson et al. [119] to determine iron in frozen seawater. To a 200 ml aliquot of sample was added 1 ml of a solution containing sodium diethyldithiocarbamate (1% w/v) and ammonium pyrrolidine dithiocarbamate (1% w/v) at pH to 4. The solution was extracted three times with 5 ml volumes of 1,1,2 trichloro-1,2,2 trifluoroethane, and the organic phase evaporated to dryness in a silica vial and treated with 0.1 ml Ultrex hydrogen peroxide (30%) to initiate the decomposition of organic matter present. After an hour or more, 0.5 ml 0.1 M hydrochloric acid was added and the solution irradiated with a 1000 W Hanovia medium pressure mercury vapour discharge tube at a distance of 4 cm for 18 minutes. The iron in the concentrate was then compared with standards in 0.1 M hydrochloric acid using a Perkin-Elmer Model 403 Spectrophotometer fitted with a Perkin-Elmer graphite furnace (HGA 2200).

The coefficient of variation of analyses was 21% for seven subsamples containing 1.6 nmol Fe per litre, and 30% for eight subsamples at 0.6 nmol Fe per litre. The detection limit was estimated to be 0.2 nmol Fe per litre.

The efficiency of the extraction procedure was tested using seawater spiked with iron-59, which gave a recovery of 97%, and with stable iron, which gave a recovery of 86%.

5.28.3

Chemiluminescence

The classical chemiluminescence method using a luminol–hydrogen peroxide system [341, 348] is thought to be a promising method for the shipboard analysis of iron because it is highly sensitive to iron and requires only a small

size detection device. However, iron (III) must be separated from the other heavy metal ions, such as manganese (II), chromium (III), cobalt (II), and copper (II) prior to detection, since the method is not specific to iron (III). To overcome these problems, Obata et al. [349] have developed an automated analytical method for determining iron in seawater using a closed flow system with a combination of a chelating resin concentration and chemiluminescence detection.

This method is based on a combination of selective column extraction using chelating resin, and improved chemiluminescence detection in a closed flow-through system. In this method, iron (III) in an acidified sample solution is selectively collected on 8-quinolinol immobilised chelating resin and then eluted with dilute hydrochloric acid. The resulting eluent is mixed with luminol solution, aqueous ammonia, and hydrogen peroxide solution successively, and then the mixture is introduced into the luminescence cell. The iron concentration is obtained from the chemiluminescence intensity. The detection limit of iron (III) is 0.05 nmol/l when using an 18 ml seawater sample. This method was applied to ordinary oceanic waters and hydrothermal waters collected in the North and South Pacific Oceans. O'Sullivan et al. [356] determined down to 0.1 nmol/kg ferrous iron in seawater by oxidation with oxygen, followed by determination by a catalysed Luminol chemiluminescence method.

Eirod et al. [352] determined sub-nanomolar levels of iron (II) and total dissolved iron in seawater by flow injection analysis with chemiluminescent detection in amounts down to 0.45 nmol/l.

5.28.4

Voltammetry

Brendel and Luther [356] have described a solid-state voltammetric gold analyser microelectrode for the measurement of iron and magnesium in pore waters.

5.28.5

Radioisotope Dilution

Radioisotope dilution using the chelating agent bathophenanthroline has been used to determine down to 5 $\mu\text{g/l}$ iron in seawater [357].

See Sects. 5.74.4–5.74.5 and 5.74.8–5.74.17.

5.29

Lanthanum

See Sect. 5.74.16.

5.30

Lead

5.30.1

Atomic Fluorescence Spectroscopy

Bolshov et al. [358] used this technique to determine low lead concentrations. A detection limit of 0.05 pg ml^{-1} was achieved in studies with aqueous solutions as reference using a graphite atomiser.

Laser-excited atomic fluorescence spectrometry has been used to determine down to 1 ng/l of lead in seawater [359].

5.30.2

Flow Injection Analysis

Ke and Lin [360] coupled a flame laser-enhanced ionisation technique with the flow-injection analysis system to measure the traces of lead in aqueous solution and in seawater. The flow-injection manifold is incorporated with a microcolumn packed with a C_{18} bonded silica. The chelating agent DDPA is used to form the Pb-DDPA complex, which may be sorbed in the microcolumn and then eluted with methanol. The preconcentration lead is then detected by the flame laser-enhanced ionization technique with either single-step or two-step extraction. At 5 and 15 ml volume-fixed sample loading, the detection limits of 0.011 and 0.0033 ng/ml (11 and 3.3 ppt) and enrichment factors of 16 and 48 are achieved, respectively, using a two-step flow-injection flame laser-enhanced ionisation. The sensitivity of the current system proves to be better by at least an order of magnitude than that of conventional flame laser-enhanced ionisation method. The flow injection flame laser-enhanced ionisation instrument also increases the tolerance of matrix interference. The flame laser-enhanced ionisation signal is slightly reduced to 80% intensity as $10\,000 \text{ }\mu\text{g/ml}$ (ppm) sodium and potassium matrixes are mixed in the lead solution. The resistance to the alkali matrixes is approximately four times the figure reported previously using a similar water-immersed probe as a flame laser-enhanced collector. Finally, the flow injection flame laser-enhanced ionisation technique was applied to detect the lead content in seawater, achieving a result of $0.0112 \pm 0.00006 \text{ ng/mL}$ (ppb), consistent with the certified value of $0.013 \pm 0.0005 \text{ ng/mL}$ ($\sim \text{ppb}$).

5.30.3

Atomic Absorption Spectrometry

Various workers [361–365] have applied graphite furnace atomic absorption spectrometry to the determination of lead in seawater.

The large amount of sodium chloride in seawater samples causes nonspecific absorption [366–370], which can only be partially compensated by background correction. In addition the seawater matrix may give rise to chemical as well as physical interferences related to the complex physico-chemical phenomena [371–373] associated with vaporization of metals and of the matrix itself.

Several matrix modifiers, which alter the drying or charring properties of the sample matrix, have been tested [374–378] to reduce nonspecific absorption. However, the matrix modification methods do not permit determinations of the indigenous lead in seawater because of the relatively high detection limit and poor precision, and yet gross chemical manipulations of the samples should be avoided to prevent contaminations which can be dramatic when the analyte is present at $\mu\text{g/l}$ or sub- $\mu\text{g/l}$ level.

With the temperature-controlled heating method described by Lundgren et al. [397], the heating rate can be chosen independently of final temperature, thus permitting a selective volatilisation. However, this method cannot be used successfully for the determination of lead in strong sodium chloride solutions like seawater, because the temperature at which atomisation of lead is rapid coincides with the volatilization temperature of sodium chloride. Ashing of seawater samples by a hydrogen diffusion flame [380] was successful in the direct determination of iron, nickel, and copper but cannot be applied to lead because hydrogen is not sufficiently effective as a suppressor for the lead–NaCl system.

In order to overcome the problem of the high nonspecific absorption, alternative procedures have been tested, which involve prior separation of the trace metals from the salt matrix. Examples of extraction of trace metals from seawater as chelates with subsequent determination by electrothermal atomic absorption spectrometric procedures have been described [381,382], but these and similar methods are seldom effective and satisfactory when the matrix is very complex and the analyte concentration very low.

In contrast, the coupling of electrochemical and spectroscopic techniques, e.g., electrodeposition of a metal followed by detection by atomic absorption spectrometry, has received limited attention. Wire filaments, graphite rods, pyrolytic graphite tubes, and hanging drop mercury electrodes have been tested [383–394] for electrochemical preconcentration of the analyte to be determined by atomic absorption spectroscopy. However, these *ex situ* preconcentration methods are often characterised by unavoidable irreproducibility, contaminations arising from handling of the support, and detection limits unsuitable for lead detection at sub-ppb levels.

These drawbacks could be certainly avoided by performing *in situ* deposition. The sole attempt in this direction was made by Torsi [395], who set up an apparatus which permitted both *in situ* electrochemical preconcentration of the analyte from a flowing solution and almost complete suppression of matrix effects because the matrix could be removed by suitable washing. The feasibility of this approach was successfully tested with respect to lead determinations

in different salt solutions (mainly ammonium acetate), and some preliminary results were reported for real samples of seawater.

Torsi et al. [395] have carried out a systematic investigation to establish the potential value of such an apparatus. The apparatus is basically an electrothermal device in which the furnace (or the rod) is replaced by a small crucible made of glassy carbon. Figure 5.10 provides an overall view of the apparatus. Figure 5.11 shows a block diagram of the electrolysis circuit; the crucible (6) acts a cathode, while the anode is a platinum foil dipped into either the sample solution reservoir (1) or the washing solution reservoir (2). Pre-electrolysis was performed at constant current with a 500 V dc variable power supply (5). Under these conditions, the cathode potential is not controlled, so that other metals can be codeposited with lead.

A typical measurement was performed as follows. The feeder was lowered into the crucible and the sample solution (seawater) was allowed to flow under an inert atmosphere with the suction on. A constant current was applied for a predetermined time. When the pre-electrolysis was over, the flow was changed from the sample to the ammonium acetate washing solution, while the deposited metals were maintained under cathodic protection. Ammonium acetate was selected for its low decomposition temperature, and a 0.2 ml l^{-1} concentration was used to ensure sufficient conductivity. At this point the feeder tip was raised to the highest position and the usual steps for an electrothermal atomic absorption spectrometry measurement were followed: drying for 30 s at 90°C , ashing for 30 s at 700°C , and atomization for 8 s at 1700°C , with measurement at 283.3 nm. The baseline increases smoothly with time as a consequence of an upward lift of the crucible caused by thermal expansion of the material.

A deviation from linearity is observed in the calibration curve at higher lead concentrations. The estimated value for the original sample was found to be $0.51 \mu\text{g/l}$, with confidence limits at the 95% confidence level of $\pm 0.036 \mu\text{g/l}$, compared with a value of $0.65 \pm 0.08 \mu\text{g/l}$ obtained by anodic scanning voltammetry. This value is well within the normal range reported in the literature for the natural lead content of unpolluted seawater. A detection limit of 0.03 ng ml^{-1} was obtained.

Halliday et al. [396] have described a simple rapid graphite furnace method for the determination of lead in amounts down to $1 \mu\text{g/l}$ in polluted seawater. The filtered seawater is diluted with an equal volume of deionised water, ammonium nitrate added as a matrix modifier, and aliquots of the solution injected into a tantalum-coated graphite tube in an HGA-2200 furnace atomiser. The method eliminates the interference normally attributable to the ions commonly present in seawater. The results obtained on samples from the Firth of Forth (Scotland, UK) were in good agreement with values determined by anodic stripping voltammetry.

Hirao et al. [964] concentrated lead in seawater using a chloroform solution of dithizone and determined it in amounts down to $40 \mu\text{g/l}$ by graphite furnace atomic absorption spectrometry. Lead in 1 kg acidified seawater was

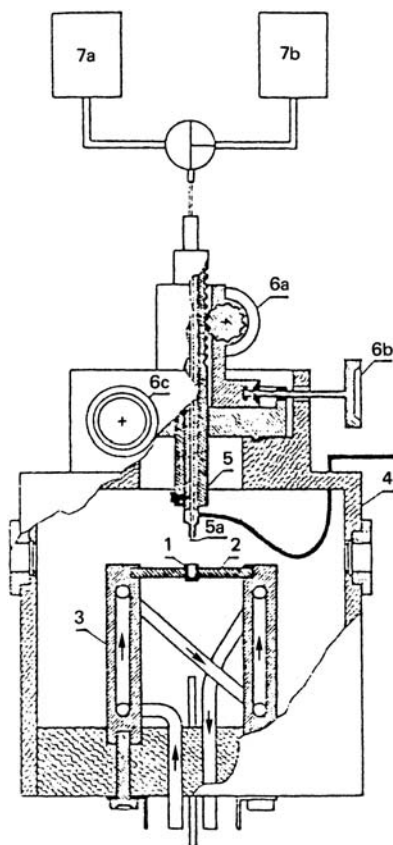
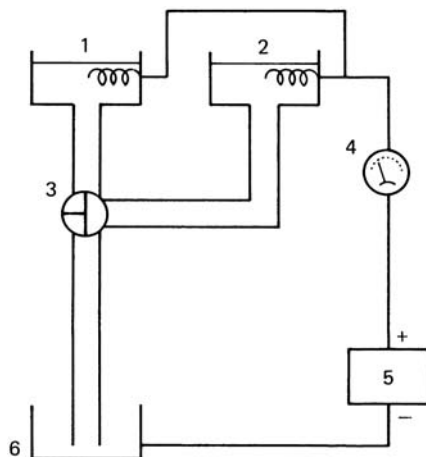

Figure 5.10. Overall view of the apparatus. 1 Vitreous carbon crucible. 2 Graphite rod. 3 Water-cooled steel column electrical leads. 4 Plexiglas cover. 5 Feeder. 5a Feeder tip. 6a–c Slide knobs. 7a,b Washing and sample solution reservoirs. The glassy carbon crucible (1) is 8 mm high, 5 mm OD, 3 mm ID, and 6 mm deep (Carbone Lorraine, Paris). The graphite rods (2) hold the crucible firmly in position. Water-cooled stainless steel columns (3) force the graphite rods against the crucible by means of two embedded screws, and also serve as electrical leads. The Plexiglas box (4) maintains the controlled inert atmosphere required to avoid drastic reduction of the absorption signal due to oxygen. The solution feeder (5) can be moved up and down by means of knob (6a) into a metal block attached to the upper part of the Plexiglas box. A three-way stopcock at the top of the cylinder connects the feeder tip (5a) to the washing and sample solution reservoirs via Teflon tubing (1.5 mm OD, 0.8 mm ID). Additional slide knobs (6b and c) move the feeder in the horizontal plane, facilitating micrometric positioning of the feeder tip. Source: [395]

equilibrated with lead of a known radioactivity, extracted with dithizone in chloroform, back-extracted with 0.1 M hydrochloric acid and subjected to graphite furnace atomic absorption spectrometry by a two-channel spectrometer. Recovery yield of lead was found to be 60–90% from the radioactivity

Figure 5.11. Electrolysis circuit layout. 1, 2 Sample and washing solution compartments. 3 Three-way stopcock. 4 Ammeter. 5 500 V Variable dc power supply. 6 Crucible. Source: [395]



of ^{212}Pb in the back-extract. Lead concentrations were thus determined with about 10% precision.

Ohta and Suzuki [397] investigated the electrothermal atomisation of lead for accurate determination of lead in water samples. Thiourea served to lower the atomisation temperature of lead and to eliminate the interferences from chloride matrix. The addition of thiourea also allowed the accurate determination of lead irrespective of its chemical form. The absolute sensitivity (1% absorption) was 1.1×10^{-12} g of lead. The method permits the direct rapid determination of lead in water samples including seawater.

No severe interference was noted in this method for arsenic, bismuth, calcium, copper, iron, magnesium, antimony, selenium, tin, and tellurium.

Sturgeon et al. [398] applied in situ metal trapping to the determination of lead in seawater.

In this method, inorganic lead in seawater samples are converted to tetraethyllead using sodium tetraethylboron ($\text{NaB}(\text{C}_2\text{H}_5)_4$) which is then trapped in a graphite furnace at 400°C . Quantitation is achieved by using a simple calibration graph prepared from aqueous standards. An absolute detection limit of (3σ) 14 pg is achieved. Precision of determination at 100 pg ml^{-1} is 4% relative standard deviation.

Izumi et al. [948] used X-ray absorption fine structure combined with fluorescence spectrometry to monitor trace amounts of lead in seawaters.

5.30.4

Anodic Stripping Voltammetry

Clem [399] has described an electrochemical cell in which rapid deoxygenation of the sample solution is achieved by allowing a jet of nitrogen to impinge on the surface of the liquid, while the cell is rotated to maintain the solution as a thin

film on the cell wall; 15 ml of solution can be deoxygenated in 1 to 1.5 minutes. Stirring during analysis is by periodic reversal of the cell rotation. The cell has been used for determining, by anodic-stripping voltammetry, 11.2 and 4.1 parts per 10^9 of lead in acidified seawater (pH 2), and for the amperometric titration (with lead) of organic ligands in non-acidified seawater.

Early work [400] on the application of cyclic and anodic stripping voltammetry to the determination of lead showed a poor correlation between peak current values and Pb^{11} concentration at high pH values. This is due to the low electrochemical activity of $PbOH$.

Acebal et al. [401] discussed the quantitative behaviour of lead (and copper) when voltammetric determinations are done at mercury film electrodes and hanging mercury drop electrodes. The samples were collected in polyethylene bottles and, generally, were not acidified immediately after collection. This might place some doubt on the results reported.

Voltammetric measurements were done with a PAR Electrochemical System (Model 174-A) and a saturated calomel reference electrode, a platinum wire auxiliary electrode and a glassy carbon rod (PAR 0333) coated with a mercury film as the working electrode. A Pyrex glass cell was used for measurements with the hanging drop mercury electrode; either this cell or a Teflon cell was used with the mercury film electrode. No advantage concerning adsorption or contamination was found when a Teflon cell was used for seawater at pH 2. Stirring was done magnetically. Nitrogen with a maximum oxygen content of 10 ppm was used as purging gas. Mercury (II) nitrate used to form in situ films on the glassy carbon rod was prepared from tridistilled mercury and nitric acid.

This work showed that application of the linear sweep mode at pH 1.5 is a fast and reliable way of dealing with interferences caused by organic materials in polluted water. The lower sensitivity of this mode limits its use to lead contents exceeding $0.1 \mu\text{g}/\text{kg}$ but such levels are commonly reached in polluted waters.

The determination of lead in seawater collected from 14 stations in Guanabara Bay gave values between 0.07 and $5.5 \mu\text{g}/\text{kg}$.

Quentel et al. [402] studied the influence of dissolved organic matter in the determination of lead in seawater by anodic stripping voltammetry.

Svensmark [403] gives details of equipment and procedure for the rapid determination of lead by a modification of anodic stripping voltammetry, using staircase voltammetry at high scan rates to strip the lead plated on a rotating mercury-film electrode. This allowed rapid determination of lead without the need for de-oxygenation, rest periods, electrode rotation or stirring. Lead at a concentration as low as $0.1 \mu\text{g}/\text{l}$ could be determined in less than 4 minutes. Results obtained on a sample of seawater are presented.

To determine down to 6 ppt of lead in seawater Wu and Batley [404] used absorptive stripping voltammetry with ligand competition using xylenol orange.

Garcia-Monco Carra et al. [405] have discussed the use of a "hybrid" mercury film electrode for the voltammetric analysis of lead (and copper) in acidified seawater.

5.30.5

Mass Spectrometry

Flegal and Stukas [406] described the special sampling and processing techniques necessary for the prevention of lead contamination of seawater samples, prior to stable lead isotopic ratio measurements by thermal ionisation mass spectrometry. Techniques are also required to compensate for the absence of an internal standard and the presence of refractory organic compounds. The precision of the analyses is 0.1–0.4% and a detection limit of 0.02 ng/kg allows the tracing of lead inputs and biogeochemical cycles.

5.30.6

Miscellaneous

Baena et al. [949] studied the speciation of lead in environmental waters.

Ultraviolet spectroscopy has been applied to the determination of lead and lead speciation studies [407]. Scaule and Patterson [408] used isotope dilution-mass spectrometry to determine the lead profile in the open North Pacific Ocean.

See also Sects. 5.74.4–5.74.16.

5.31

Lithium

5.31.1

Atomic Absorption Spectrometry

Benzwi [409] determined lithium in Dead Sea water using atomic absorption spectrometry. The sample was passed through a 0.45 μm filter and lithium was then determined by the method of standard additions. Solutions of lithium in hexanol and 2-ethylhexanol gave greatly enhanced sensitivity.

5.31.2

Gel Permeation Chromatography

Rona and Schmuckler [410] used gel permeation chromatography to separate lithium from Dead Sea brine. The elements emerged from the column in the order potassium, sodium, lithium, magnesium, and calcium and it was possible to separate a lithium-rich fraction also containing some potassium and sodium but no calcium and magnesium.

5.31.3

Neutron Activation Analysis

Wiernik and Amiel [411] used neutron activation analysis to measure lithium and its isotopic composition in Dead Sea brines.

See also Sect. 5.74.4.

5.32 Lutetium

See Sect. 5.49.14.

5.33 Magnesium

5.33.1 Gravimetric Method

Das et al. [412] carried out a direct gravimetric determination of magnesium in seawater by precipitation with *N*-benzoyl-*N*-phenylhydroxylamine. The precipitate is weighed as $\text{Mg}(\text{C}_{13}\text{H}_{10}\text{O}_2\text{N})_2$. The coefficient of variation for 5 mg of magnesium was 0.55%. Magnesium could be determined in the presence of barium or strontium; coprecipitation of calcium was avoided by adding tartrate, nickel, cobalt, copper, mercury, and zinc were masked with cyanide and tartrate. Phosphate, oxalate, fluoride, and EDTA interfered. Tin, iron, aluminium, and beryllium were separated by prior precipitation with *N*-benzoyl-*N*-phenylhydroxylamine at pH 0.5 to 1.0, 3.5, 4.0 and 5.5, respectively.

5.33.2 Atomic Absorption Spectrometry

Atomic absorption spectrometry has been used to determine magnesium in seawater [413–415].

See also Sects. 5.74.1 and 5.74.2.

5.34 Manganese

The natural water chemistry of manganese, which is an important trace element both biologically and geologically, is complicated by non-equilibrium behaviour. From thermodynamic considerations manganese dioxide (manganese (IV)) is expected to be the stable form of manganese in seawater [416]. However, seawater contains a significant quantity of dissolved manganese (II) which is only slowly oxidised (Murray and Brewer [417]). Investigations of the oxidation of manganese (II) have shown that the process is autocatalytic, the product being a solid manganese oxide phase whose composition depends on the reaction conditions [417–420]. The heterogenous nature of the oxidation process can thus account for the extremely slow oxidation of manganese (II) in seawater where concentrations of particulate matter can be relatively small.

Estuaries, in contrast, appear to be important sites for manganese redox reactions. Manganese maxima have been observed in several estuaries [421–423]

and it has been suggested that these maxima result from a recycling of precipitated manganese [423]. The proposed mechanism is essentially a redox cycle in which dissolved manganese (II) is oxidised into the water column and precipitated. Reduction in anoxic sediments results in the subsequent release of manganese (II) to the water column.

The details of estuarine manganese chemistry are far from clear, however Sholkovitz [424] notes that while adsorption onto colloidal humic acids or hydrous iron oxides is a major factor controlling the removal of many trace metals from estuarine waters, manganese does not conform to this pattern as it is known to behave independently of iron and associates only weakly with organic matter. Detailed investigation of estuarine manganese reactions requires analytical methods specific to the species involved; a requirement met only by electrochemical methods at natural concentration levels. Davison [425, 426] has described the use of direct polarographic methods in the analysis of manganese in lake waters in the concentration range 0.1–5 mg/l.

Manganese is of particular interest because of its central role in many marine geochemical processes and involvement in biological systems.

Manganese and many other trace metals are present in open ocean waters at concentrations in the order of nmol/l or less, and it is only relatively recently, when adequate contamination control measures have been applied during sampling and measurements, that accurate data have been obtained.

Manganese is a geochemically active element in the ocean. The dissolved manganese is easily precipitated by oxidation to manganese (IV) oxide, which acts as a powerful scavenger for trace elements. The solidified manganese in sediments is reduced to manganese (II) and is regenerated into the water column under mild reducing conditions, for example in the oxygen minimum zone and the near-shore anoxic sediments. In recent years, it has also been found that a copious amount of manganese is injected into the deep waters by hydrothermal emanations through the active ocean crusts. Therefore it is very important to clarify the distribution of manganese in seawater to understand marine geochemistry. Furthermore, manganese is thought to be a promising element as a chemical tracer for probing the hydrothermal activities if it can be analysed easily and quickly onboard ship.

5.34.1

Spectrophotometric Methods

Olafsson [427] has described a semiautomated determination of manganese in seawater using leucomalachite green. The autoanalyser had a 620 nm interference filter and 50 minute flow cells. Findings indicated initial poor precision was related to pH, temperature, and time variations. With strict controls on sample acidity and reaction conditions, the semiautomated method had high precision, at least as good as that achieved by preconcentration and atomic absorption procedures, and provided precise, rapid, shipboard information

on the continental distribution of manganese and anomalies associated with geothermal sea-floor activity. The method was not suitable for estuarine samples, nor quite sensitive enough for study of the open ocean manganese distribution.

Brewer and Spencer [428] have described a method for the determination of manganese in anoxic seawaters based on the formulation of a chromophore with formaldoxime to produce a complex with an adsorption maximum at 450 nm. Sulfide (50 $\mu\text{g/l}$), iron, phosphate (8 $\mu\text{g/l}$), and silicate (100 $\mu\text{g/l}$) do not interfere in this procedure. The detection limit is 10 $\mu\text{g/l}$ manganese.

5.34.2

Spectrofluorometric Method

Biddle and Wehry [429] carried out fluorometric determination of manganese II in seawater via catalysed enzymic oxidation of 2,3-diketogluconate. The detection limit was 8 $\mu\text{mol l}^{-1}$ Mn (II).

5.34.3

Atomic Absorption Spectrometry

Graphite-furnace atomic absorption spectrometry, although element-selective and highly sensitive, is currently unable to directly determine manganese at the lower end of their reported concentration ranges in open ocean waters. Techniques that have been successfully employed in recent environmental investigations have thus used a preliminary step to concentrate the analyte and separate it from the salt matrix prior to determination by atomic absorption spectrometry.

The determination of manganese in seawater using graphite furnace atomic absorption spectrometry has been investigated by many workers [129, 430–437]. If the seawater matrix is atomized along with the analyte, the result is a large background signal which is often beyond the correcting capabilities of current instrumentation. The presence of large amounts of chlorides has also been shown to provide interferences [438, 439], usually making direct analysis difficult.

To ameliorate such problems, most workers either have used matrix modification or have extracted the metal from the seawater matrix [129, 430, 432–434, 437]. Few workers have been successful with the direct determination in seawater after volatilisation of the matrix during the char program step [430, 431, 435, 436, 439, 440]. Slavin and Manning [441–443] have shown that by using a furnace at steady-state temperature (the L'vov platform), the interference of chloride on manganese determination was greatly reduced as long as the background signal was within limits that the deuterium arc background corrector could handle.

Segar and Gonzalez [431] attributed the reduced sensitivity to manganese in seawater matrix to covolatilisation of some manganese with the salt matrix. More recent work suggests that this reduced sensitivity is due to vapour-phase binding of a portion of the manganese by chloride.

Segar and Cantillo [436] developed a direct method for manganese in seawater with a detection limit for manganese of about $0.3 \mu\text{g/l}$. Only ordinary graphite tubes were available, and they found that as the tube aged, the analytical signal fell linearly at a rate of 50% per 100 firings. Since variations in salinity produced relatively large changes in signal, the method of standard additions was required.

McArthur [433] preferred to use ammonium nitrate matrix modification to determine manganese in seawater. Most of his paper discussed the charring process. He found considerable salinity dependence if charring was too rapid. There was considerable change in the salinity dependence with the age of the tubes.

Kingston et al. [129] resorted to extraction on Chelex 100 followed by stripping with nitric acid. The ammonium nitrate matrix modification technique was used by Montgomery and Peterson [437] for the determination of manganese in seawater. They showed that the pyrolytically coated tubes they used deteriorated very rapidly when they used the combination of ammonium nitrate and seawater. Manganese was determined in seawater (with copper and cobalt) by Hydes [465] after adding 1% ascorbic acid to the sample. He used the Perkin-Elmer HGA-2100 furnace and found significant loss of manganese from seawater between 600°C and 900°C .

The direct furnace method of Sturgeon et al. [430] for manganese was very similar to the method of Segar and Cantillo [472]. The Sturgeon detection limit was $0.22 \mu\text{g/l}$ for manganese in seawater, using $20 \mu\text{l}$ samples in the HGA-2200 furnace and pyrolytically coated graphite tubes. They found a loss in sensitivity during the life of the tubes. They had to use the method of additions to accommodate small residual interference.

Procedures using chelation followed by extraction have been described for manganese using the 8-hydroxy-quinoline-chloroform system [432, 444]. Dithiocarbamate systems can simultaneously extract manganese, along with other trace metals under suitable conditions [445–447].

Statham [448] has optimised a procedure based on chelation with ammonium dithiocarbamate and diethylammonium diethyldithiocarbamate for the preconcentration and separation of dissolved manganese from seawater prior to determination by graphite furnace atomic absorption spectrometry. Freon TF was chosen as solvent because it appears to be much less toxic than other commonly used chlorinated solvents, it is virtually odourless, has a very low solubility in seawater, gives a rapid and complete phase separation, and is readily purified. The concentrations of analyte in the back-extracts are determined by graphite furnace atomic absorption spectrometry. This procedure concentrates the trace metals in the seawater by a factor of 67.3.

When a 350 ml seawater sample was spiked with ^{54}Mn and taken through the chelation, extraction, and back-extraction procedures, the observed recovery of the radio-tracer was 100.6%. Estimates of detection limits for manganese based on sets of both shipboard and shore laboratory separations are of the order of 0.1 nmol/l. The accuracy of the technique is demonstrated by data from the ICES fifth-round intercalibration exercise for trace metals in seawater [449].

Klinkhammer [432] has described a method for determining manganese in a seawater matrix at concentrations ranging from about 30 to 5500 ng/l. The samples are extracted with 4 nmol/l 8-hydroxyquinoline in chloroform, and the manganese in the organic phase is then back-extracted into 3 M nitric acid. The manganese concentrations are determined by graphite furnace atomic absorption spectrophotometry. The blank of the method is about 3.0 ng/l, and the precision from duplicate analyses is $\pm 9\%$ (1 SD).

The theoretical yield of the method is less than 100%, as only 80–90% of the aqueous phase is removed after back-extraction. The actual yield obtained by ^{54}Mn counting was $69.5 \pm 7.8\%$, and this can be allowed for in the calculation of results. Environmental Protection Agency standard seawater samples of known manganese content (4370 ng/l) gave good manganese recoveries (4260 ng/l).

Bender and coworkers [450, 451] determined total and soluble manganese in seawater. The samples were collected into 500 ml polyethylene bottles. All samples were brought to pH 2 with nitric acid free of trace metals, and stored in individual zip-lock plastic bags to minimise contamination.

When the samples were returned to the laboratory the pH was adjusted to approximately pH 8 using concentrated ammonia (Ultrapure, G. Frederick Smith). Chelating cation exchange resin in the ammonia form (20 ml; Chelex 100, 100–200 mesh, Bio-Rad) was added to the samples and they were batch extracted on a shaker table for 36 hours. The resin was decanted into columns, and the manganese eluted using 2 N nitric acid [129]. The eluant was then analysed by graphite furnace atomic absorption spectrophotometry. Replicate analyses of samples indicate a precision of about 5%.

Graphite furnace atomic absorption spectrometry with the L'vov platform and Zeeman background correction has been applied to the determination of down to 0.02 $\mu\text{g/l}$ manganese in seawater [452].

Lan and Alfassi [453] determined manganese in seawater in amounts down to 50 ppt using 50 μl sample by graphite furnace atomic absorption spectrometry.

To determine manganese [452, 454], several factors had to be controlled carefully to obtain reliable results against simple standards that were independent of salinity and variations in matrix composition. Use of the L'vov platform and integration of the absorbance signal reduced the sensitivity to matrix composition. Pyrolytically coated graphite reduced variations that depend upon the life of the tubes. The tubes appeared to fail by intercalation of the sodium or sodium chloride matrix. The char temperature must not vary outside the range 1100–1300 $^{\circ}\text{C}$. Zeeman background correction permitted use of larger

seawater samples. The detection limit of the procedure using 20 μl samples was 0.1 $\mu\text{g/l}$ (2 pg) manganese. By use of the Zeeman background corrector, less than 0.02 $\mu\text{g/l}$ manganese was detected in seawater using a 75 μl sample.

5.34.4

Polarography

Knox and Turner [454] have described a polarographic method for manganese (II) in estuarine and seawaters which covers the lower concentration range 10–300 $\mu\text{g/l}$. The method, which is specific to manganese (II) and its labile complexes, is used in conjunction with a colorimetric technique to compare the levels of manganese (II) and total dissolved manganese in an estuarine system. They showed that polarographically determined manganese (II) can vary widely from 100% to less than 10% of the total dissolved manganese, determined spectrophotometrically at 450 nm by the formaldoxine method [455] calibrated in saline medium to overcome any salt effects. It is suggested that the manganese not measured by the polarographic method is present in a colloidal form.

5.34.5

Neutron Activation Analysis

Neutron activation analysis has been used to determine total manganese in seawater.

Wiggins et al. [456] used neutrons from the thermal column of a 10 kW pool-type research reactor and from a 120 μg Cf source to study the prompt photon emission resulting from neutron capture in magnesium nodules (terromanganese oxides) from the ocean floor. Spectra were recorded with a Ce(Li) detector and a 1024-channel analyser. Complex spectra were obtained by irradiation of seawater, but it was possible to detect and estimate manganese in nodules in a simulated marine environment by means of the peaks at 7.00, 6.55, 6.22, and 6.04 μV .

See also Sects. 5.74.4–5.74.6, 5.74.8–5.74.12, and 5.74.14–5.74.17.

5.35

Mercury

5.35.1

Atomic Absorption Spectrometry

Hedeishi and McLaughlin [457] have reported the application of the Zeeman effect for the determination of mercury. Atomic absorption and atomic fluorescence techniques using closed system reduction–aeration have been applied widely to determine mercury concentrations in natural samples [458–472].

Typical of these methods is that of Topping and Pirie [468], in which the mercury is concentrated by drawing air for 5 h (600 ml/min) through a mixture of the sample (4 litres) and 20% stannous chloride solution in 5 M hydrochloric acid (45 ml), and absorbing mercury vapour from the air stream in 20 ml 2% potassium permanganate solution: 50% (v/v) sulfuric acid (1:1). To the absorption solution was added 15 ml of the stannous chloride solution, and this mixture was aerated at 2 l/min. The air and mercury vapour are passed through a 15 cm gas cell (with silica windows) in an atomic absorption spectrophotometer for measurement at 253.65 nm. Samples containing down to 2 ng/l of Hg could be analysed by this procedure.

Olafsson [472] described a similar procedure, in which the sample (450 ml) is acidified with nitric acid, aqueous stannous chloride is added, and the mercury is entrained by a stream of argon into a silica tube wound externally with resistance wire and containing pieces of gold foil, on which the mercury is retained. The tube and its contents are then heated electrically to about 320 °C and the vaporised mercury is swept by argon into a 10 cm silica absorption cell in an atomic absorption spectrophotometer equipped with a recorder. The absorption (measured at 253.7 nm) is directly proportional to the amount of mercury in the range 0–24 ng per sample.

In many applications, such as the analysis of mercury in open ocean seawater, where the mercury concentrations can be as small as 10 ng/l [468, 472–476], a preconcentration stage is generally necessary. A preliminary concentration step may separate mercury from interfering substances, and the lowered detection limits attained are most desirable when sample quantity is limited. Concentration of mercury prior to measurement has been commonly achieved either by amalgamation on a noble-metal metal [460, 467, 469, 472], or by dithizone extraction [462, 472, 475] or extraction with sodium diethyldithiocarbamate [475]. Preconcentration and separation of mercury has also been accomplished using a cold trap at the temperature of liquid nitrogen.

Fitzgerald et al. [477] have described a method based on cold-trap preconcentration prior to gas-phase atomic absorption spectrometry for the determination of mercury down to 2 ng/l in seawater.

The cold trap is created by immersing a glass U-tube packed with glass beads (80/100 mesh) in liquid nitrogen. After reduction, purging, and trapping, the mercury is removed from the glass column by controlled heating, and the gas-phase absorption of eluting mercury is measured. This procedure has been employed for both shipboard and laboratory analyses of mercury in seawater.

The mercury analyses were conducted using a Coleman Instruments mercury analyser (MAS-50) equipped with a recorder. The aqueous sample solution was contained in a 250 ml Pyrex glass bubbler placed at one end of a sampling train employing nitrogen as the purging and carrier gas. A schematic diagram of the entire system is shown in Fig. 5.12.

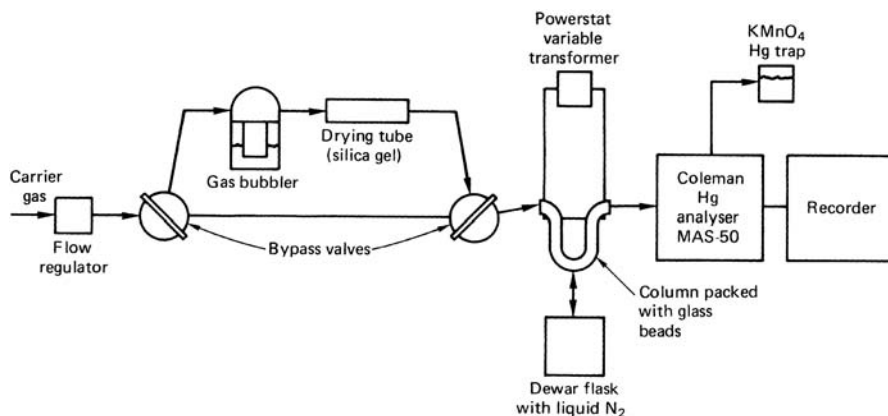

Figure 5.12. Hg cold-trap preconcentration system for the determination of mercury by gas-phase absorption. Source: [477]

Fitzgerald et al. [477] showed that the most significant quantities of mercury occurred in the waters of the Atlantic Ocean's continental shelf and slope (21–78 ng/l), compared with open ocean samples (2–11 ng/l).

These workers distinguished between inorganic mercury obtained by direct analysis on the sample as received, and organic mercury (the difference between total mercury obtained upon ultraviolet irradiation of the sample and inorganic mercury).

Olafsson [478] has reported on the results obtained in an international intercalibration for mercury in seawater. Sixteen countries participated in this exercise, which involved analysis of a seawater and seawater spiked with 15.4 and 143 ng/l mercury. The results show good accuracy and precision in the recovery of mercury for the majority of calibrations, but serious errors in the low-level determinations on the seawater.

Since the intercalibration samples had been ultraviolet-irradiated, the majority of participants in this exercise preferred to analyse the samples without any pretreatment. Ten did, however, employ oxidising pretreatment, and with three exceptions the results suggest that this approach should be taken with great caution.

Half of the participants preconcentrated mercury from the seawater prior to determination, eleven by amalgamation on gold, one by amalgamation on silver, two by collection into oxidising solutions, one by organic extraction, and one by ion exchange chromatography.

Reduction to metallic mercury was used by an overwhelming proportion of the participants, with stannous chloride as reductant in all but one case in which sodium borohydride was used. In all cases but four, the participants used cold-vapour atomic absorption for final determination. This makes comparison of detection techniques difficult, but the good results ob-

tained by cold-vapour atomic fluorescence are of interest and the spurious results obtained by differential pulse anodic stripping voltammetry may be indicative of the risk of mercury contamination in polarographic laboratories.

Filippelli [479] determined mercury at the subnanogram level in seawater using graphite furnace atomic absorption spectrometry. Mercury (II) was concentrated using the ammonium tetramethylenedithiocarbamate (ammonium pyrrolidine-dithiocarbamate, APDC)-chloroform system, and the chloroform extract was introduced into the graphite tube. A linear calibration graph was obtained for 5–1500 ng of mercury in 2.5 ml chloroform extract. Because of the high stability of the Hg^{II} -APDC complexes, the extract may be evaporated to obtain a crystalline powder to be dissolved with a few microlitres of chloroform.

About 84% of mercury was recovered in a single extract (97% in two extractions). The calibration graph was prepared by plotting the peak height against amount of mercury added to 500 ml distilled water. The optimized experimental conditions are as follows: lamp current, 6 mA; wavelength, 253.63 nm; drying, 100 °C for 10 s; ashing, 200 °C for 10 s; atomisation, 2000 °C for 3 s; and purge gas, nitrogen “stopped flow”.

The coefficient variation of this method was about 2.6% at the 1 µg/l mercury level. The calibration graph is linear over the range 5–1500 µg mercury.

Blake [480] has described a method for determination of trace amounts of mercury, with a limit of detection of less than 2 ng/l in fresh and saline waters. It was based on generating mercury vapour from the sample by reduction, together with trapping on gold mesh, subsequent desorption and measurement by cold vapour atomic absorption spectrometry. Checks on the precision and recovery of the method with respect to inorganic mercury are described, and the recovery of methyl mercury was also investigated. The performance of the method was within the limits implied in the requirements of the Harmonised Monitoring scheme and the application of EC Directives concerned with water quality monitoring.

Gill and Fitzgerald [481] determined picomolar quantities of mercury in seawater using stannous chloride reduction and two-stage amalgamation with gas-phase detection. The gas flow system used two gold-coated bead columns (the collection and the analytical columns) to transfer mercury into the gas cell of an atomic absorption spectrometer. By careful control and estimation of the blank, a detection limit of 0.21 pM was achieved using 2 l of seawater. The accuracy and precision of this method were checked by comparison with aqueous laboratory and National Bureau of Standards (NBS) reference materials spiked into acidified natural water samples at picomolar levels. Further studies showed that at least 88% of mercury in open ocean and coastal seawater consisted of labile species which could be reduced by stannous chloride under acidic conditions.

5.35.2

Inductively Coupled Plasma Mass Spectrometry

Bloxam et al. [482] used liquid chromatography with an inductively coupled plasma mass spectrometric detector in speciation studies on ppt levels of mercury in seawater.

Turyan and Mandler [483] determined ppt levels of mercury in seawater by first converting mercury salts to elemental mercury using stannous chloride, the mercury was then trapped on gold deposited on platinum gauze and released by heating prior to determination by inductively coupled plasma mass spectrometry.

Debrak and Denoyer [484] determined mercury at the ppt level in seawater by the addition of tin chloride to produce hydrogen vapour, and trapping on gold-platinum gauze, prior to heating and detection of the mercury released by inductively coupled plasma mass spectrometry.

5.35.3

Inductively Coupled Plasma Atomic Emission Spectrometry

Watling [491] has described an analytical technique for the accurate determination of mercury at picogram per litre levels in fresh and seawater. Mercury, released by tin (II) chloride reduction of water samples is amalgamated onto silver wool contained in quartz amalgamation tubes. The wool is then heated and the mercury thus released is flushed by argon into a plasma where it is excited. The emission signal thus produced results in a detection limit of 3×10^{-17} g and an analytical range 1×10^{-14} g– 1×10^{-7} g.

5.35.4

Atomic Emission Spectrometry

Wrembel [485] gives details of a procedure for the determination of mercury in seawater by low-pressure ring-discharge atomic emission spectrometry with electrolytic preconcentration on copper and platinum mesh electrodes. Between 40 ± 5 (open sea) and 50 ± 8 (shore area) $\mu\text{g/l}$ mercury was found in Baltic sea waters.

Wrembel and Pajak [486] evaporated mercury from natural water samples with argon and amalgamated the mercury with a gold foil. The mercury was excited in a ring-discharge plasma and determined by atomic emission spectroscopy. The method was applied to the determination of mercury in seawater in the range 0.01–1.0 $\mu\text{g/l}$.

5.35.5

Colloid Flotation

Voyce and Zeitlin [487] have used adsorption colloid flotation to determine mercury in seawater. The sample 500 ml is treated with concentrated hy-

drochloric acid; an aqueous solution of cadmium sulfate and a fresh aqueous solution of sodium sulfate are added. The pH is adjusted to pH 1.0 and then poured into a flotation cell with a nitrogen flow of 10 ml/min. Ethanolic octadecyltrimethylammonium chloride is injected and the froth dissolved in aqua regia in a flameless atomic absorption cell.

Following reduction of mercury with stannous chloride the mercury vapour is flushed from the system.

To determine organically bound mercury, the sample is treated (500 ml) with 0.5 M sulfuric acid aqueous potassium permanganate and set aside for 24 h. Aqueous hydroxylammonium chloride is added and the determination completed as above. The amount of mercury in the samples is calculated by reference to the standard absorptions. Average recoveries of 0.05 μg mercury were 88%.

Agemian and Da Silva [488] have described an automated method for total mercury in saline waters.

Bioassay methods have been used to obtain estimates of low mercury concentrations (5–20 $\mu\text{g/l}$) in seawater [489]. This method is useful for detecting comparatively small enhancements over background mercury concentrations in estuarine and seawater.

This method consists of suspending for a standard time 70 mussels (*Mytilus edulis*), each of a standard weight, in a plastic coated wire cage 2 m below the surface. Mercury in the mussels was determined by cold vapour atomic

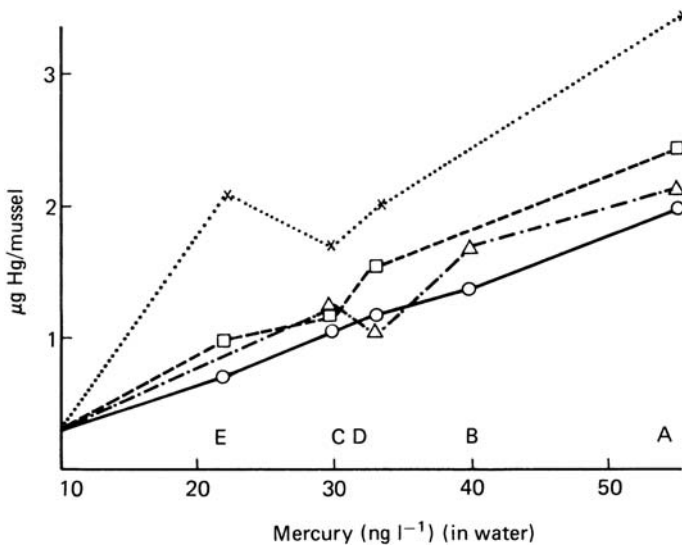

Figure 5.13. Relationship between mean total mercury concentration in water at the cage positions (A–E) and the mercury loadings per mussel after various exposure times. ○ = 28 days; △ = 55 days; □ = 106 days; × = 153 days. Source: [489]

absorption spectrometry [468, 490]. The procedure is calibrated by plotting determined mercury content of mussels against the mercury content of the seawater in the same area (Fig. 5.13).

5.35.6

Miscellaneous

Other techniques that have been used include subtractive differential pulse voltammetry at twin gold electrodes [492], anodic stripping voltammetry using glassy-carbon electrodes [495, 496], X-ray fluorescence analysis [493], and neutron activation analysis [494].

See also Sects. 5.74.5, 5.74.9, 5.74.11, 5.74.14, and 5.74.15.

5.36

Molybdenum

5.36.1

Spectrophotometric Methods

Kawabuchi and Kuroda have concentrated molybdenum by anion exchange from seawater containing acid and thiocyanate [497] or hydrogen peroxide [497, 498], and determined it spectrophotometrically. Korkisch et al. [499] concentrated molybdenum from natural waters on Dowex 1-X8 in the presence of thiocyanate and ascorbic acid.

Kuroda and Tarui [498] developed a spectrophotometric method for molybdenum based on the fact that Mo^{VI} catalyses the reduction of ferric iron by divalent tin ions. The plot of initial reaction rate constant versus molybdenum concentration is rectilinear in the range 0.01–0.3 mg/l molybdenum. Several elements interfere, namely, titanium, rhenium, palladium, platinum, gold, arsenic, selenium, and tellurium.

In a method described by Kiriya and Kuroda [500], molybdenum is sorbed strongly on Amberlite CG 400 (Cl form) at pH 3 from seawater containing ascorbic acid, and is easily eluted with 6 M nitric acid. Molybdenum in the effluent can be determined spectrophotometrically with potassium thiocyanate and stannous chloride. The combined method allows selective and sensitive determination of traces of molybdenum in seawater. The precision of the method is 2% at a molybdenum level of 10 $\mu\text{g/l}$. To evaluate the feasibility of this method, Kiriya and Kuroda [500] spiked a known amount of molybdenum and analysed it by this procedure. The recoveries for 4 to 8 μg molybdenum added to 500 or 1000 ml samples were between 90 and 100%.

Nutaksuka et al. [501] converted molybdenum to its molybdenum–phenyl-fluorone complex, then extracted the complex on a membrane filter prior to spectrophotometric determination on the membrane.

5.36.2 Atomic Absorption Spectrometry

A limited amount of work has been carried out on the determination of molybdenum in seawater by atomic absorption spectrometry and graphite furnace atomic absorption spectrometry [137,502]. In a recommended procedure [503], a 50 ml sample of seawater at pH 2.5 is passed through a column of 0.5 g *p*-aminobenzylcellulose, then the column is left in contact with 1 M ammonium carbonate for 3 h, after which three 5 ml fractions are collected. Finally, molybdenum is determined by atomic absorption at 313.2 nm using the hot graphite rod technique. At the 10 mg/l level, the standard deviation was 0.13 µg.

Emerick [504] showed that sulfate interferes with the graphite furnace atomic determination of molybdenum in aqueous solutions with concentrations of only 0.1% (w/v) sodium sulfate, causing complete elimination of the molybdenum absorbance peak in solutions free of other salts. Matrix modification with 0.5% (w/v) $\text{CaCl}_2 \cdot 2\text{H}_2\text{O}$, in a volume equal to the sample, facilitates the determination of molybdenum in the presence of solutions containing as much as 0.4% (w/v) sodium sulfate. The need for matrix modification for molybdenum determination in natural waters appears to exist when sulfate greatly exceeds the equivalent calcium content. The routine use of a volume of 0.5% $\text{CaCl}_2 \cdot 2\text{H}_2\text{O}$ equal to sample volume is recommended in the determination of molybdenum in seawater.

Nakahara and Chakrabarti [137] showed that the seawater salt matrix can be removed from the sample by selective volatilisation at 1700–1850 °C, but the presence of sodium chloride, sodium sulfate, and potassium chloride causes a considerable decrease in molybdenum absorbance, and magnesium chloride and calcium chloride cause a pronounced enhancement. The presence of magnesium chloride prevents the depressive effects. Samples of less than 50 µl can be analysed directly without using a background corrector with a precision of 10%.

These workers conclude that the selective volatilisation technique is highly suitable for the determination of traces of molybdenum in synthetic (and most probably real) seawater samples. It has the advantages of freedom from contamination and loss during sample preparation and is faster, and cheaper, than procedures using separations.

The sensitivity achieved should enable seawater samples to be analysed for molybdenum, because the concentration of molybdenum in seawater is usually 2.1–18.8 µg/l. The selected temperature of 1700–1850 °C during the charring stage permits separation of the seawater matrix from the analyte prior to atomisation with the Perkin-Elmer Model 603 atomic absorption spectrometer equipped with a heated graphite atomiser (HGA-2100).

Kuroda et al. [505] determined traces of molybdenum in seawater by combined anion exchange and graphite-furnace atomic absorption spectrometry.

Trace amounts of molybdenum were concentrated from acidified seawater on a strongly basic anion exchange resin (Bio-Rad AG1 X-8 in the chloride form) by treating the water with sodium azide. Molybdenum (VI) complexes with azide were stripped from the resin by elution with ammonium chloride/ammonium hydroxide solution (2 M/2 M). Relative standard deviations of better than 8% at levels of 10 μg per litre were attained for seawater using graphite furnace atomic absorption spectrometry.

5.36.3

Inductively Coupled Plasma Mass Spectrometry

Specht and Beauchemin [506] have described an automated system to provide online addition of isotopic spikes to seawater samples in the determination of molybdenum by inductively coupled plasma mass spectrometry.

5.36.4

Electrochemical Methods

Hidalgo et al. [509] reported a method for the determination of molybdenum (VI) in natural waters based on differential pulse polarography. The catalytic wave caused by molybdenum (VI) in nitrate medium following pre-concentration by co-precipitation on ferric hydroxide was measured. For seawater samples, hexadecyltrimethylammonium bromide with octadecylamine was used as the surfactant. The method was applied to molybdenum in the range 0.7–5.7 $\mu\text{g}/\text{l}$.

Van den Berg [510] carried out direct determinations of molybdenum in seawater by adsorption voltammetry. The method is based on complex formation of molybdenum (VI) with 8-hydroxyquinoline (oxine) on a hanging mercury drop electrode. The reduction current of adsorbed complex ions was measured by differential pulse adsorption voltammetry. The effects of variation of pH and oxine concentration and of the adsorption potential were examined. The method was accurate up to 300 nmol/l. The detection limit was 0.1 nmol/l.

Willie et al. [508] used linear sweep voltammetry for the determination of molybdenum. The molybdenum was adsorbed as the Eriochrome Blue Black R complex on a static mercury drop electrode. The method was reported to have a limit of detection of 0.50 $\mu\text{g}/\text{l}$ and the results agreed well with certified values for two reference seawater samples.

Hua et al. [507] described an automated method for determination of molybdenum in seawater by means of constant-current reduction of the adsorbed 8-quinolinol complex in a computerised flow potentiometric stripping analyser. The complex was adsorbed onto a molybdenum film electrode at -0.2 V and stripped at -0.42 V . The authors report measuring molybdenum at $8.9 \pm 1.3\ \mu\text{g}/\text{l}$ in reference seawater NASS-1, with a certified value of $11.5 \pm 1.9\ \mu\text{g}/\text{l}$.

5.36.5

X-ray Fluorescence Spectrometry

X-ray fluorescence was used for the determination of molybdenum in seawater in a method described by Kimura et al. [511]. Molybdenum is coprecipitated with sodium diethyldithiocarbamate, which is measured by X-ray fluorescence. They report a detection limit of 0.3 $\mu\text{g/l}$ and a relative standard deviation of 2.9%.

5.36.6

Miscellaneous

Various other techniques have been used to determine molybdenum, including adsorption voltammetry [510], electron-paramagnetic resonance spectrometry [512], and neutron activation analysis [513, 514]. EPR spectrometry is carried out on the isoamyl alcohol soluble $\text{Mo}(\text{SCN})_5$ complex and is capable of detecting 0.46 mg/l molybdenum in seawater. Neutron activation is carried out on the β -naphthoin oxime [514] complex and the pyrrolidone dithiocarbamate and diethyldithiocarbamate complex [513]. The neutron activation analysis method [514] was capable of determining down to 0.32 $\mu\text{g/l}$ of molybdenum in seawater.

Monien et al. [515] have compared results obtained in the determination of molybdenum in seawater by three methods based on inverse voltammetry, atomic absorption spectrometry, and X-ray fluorescence spectroscopy. Only the inverse voltammetric method can be applied without prior concentration of molybdenum in the sample, and a sample volume of only 10 ml is adequate. Results of determinations by all three methods on water samples from the Baltic Sea are reported, indicating their relative advantages with respect to reliability.

Shriadah et al. [516] determined molybdenum VI in seawater by densitometry after enrichment as the Tiron complex on a thin layer of anion exchange resin. There were no interferences from trace elements or major constituents of seawater, except for chromium and vanadium. These were reduced by the addition of ascorbic acid. The concentration of dissolved molybdenum (VI) determined in Japanese seawater was 11.5 $\mu\text{g/l}$, with a relative standard deviation of 1.1%.

An adsorbing colloid formation method has been used to separate molybdenum from seawater prior to its spectrophotometric determination by the thiocyanate procedure [517].

See also Sects. 5.74.5, 5.74.6, 5.74.8, 5.74.9, 5.74.12, 5.74.14, and 5.74.15.

5.37

Neodymium

See Sect. 5.49.

5.38 Neptunium

See Sect. 7.2.6.

5.39 Nickel

5.39.1 Spectrophotometric Method

The concentration of nickel in natural waters is so low that one or two enrichment steps are necessary before instrumental analysis. The most common method is graphite furnace atomic absorption after preconcentration by solvent extraction [122] or coprecipitation [518]. Even though this technique has been used successfully for the nickel analyses of seawater [519, 520] it is vulnerable to contamination as a consequence of the several manipulation steps and of the many reagents used during preconcentration.

Nickel has been determined spectrophotometrically in seawater in amounts down to 0.5 $\mu\text{g/l}$ as the dimethylglyoxime complex [521, 522]. In one procedure [521] dimethylglyoxime is added to a 750 ml sample and the pH adjusted to 9–10. The nickel complex is extracted into chloroform. After extraction into 1 M hydrochloric acid, it is oxidised with aqueous bromine, adjusted to pH 10.4, and dimethylglyoxime reagent added. It is made up to 50 ml and the extinction of the nickel complex measured at 442 nm. There is no serious interference from iron, cobalt, copper, or zinc but manganese may cause low results.

In another procedure [522] the sample of seawater (0.5–3 litres) is filtered through a membrane-filter (pore size 0.7 μm) which is then wet-ashed. The nickel is separated from the resulting solution by extraction as the dimethylglyoxime complex and is then determined by its catalysis of the reaction of Tiron and diphenylcarbazone with hydrogen peroxide, with spectrophotometric measurement at 413 nm. Cobalt is first separated as the 2-nitroso-1-naphthol complex, and is determined by its catalysis of the oxidation of alizarin by hydrogen peroxide at pH 12.4. Sensitivities are 0.8 $\mu\text{g/l}$ (nickel) and 0.04 $\mu\text{g/l}$ (cobalt).

5.39.2 Atomic Absorption Spectrometry

Rampon and Cavelier [523] used atomic absorption spectrometry to determine down to 0.5 $\mu\text{g/l}$ nickel in seawater. Nickel is extracted into chloroform from seawater (500 ml) at pH 9–10, as its dimethylglyoxime complex. Several extractions and a final washing of the aqueous phase with carbon tetrachloride

are required for 100% recovery. The combined organic phases are evaporated to dryness and the residue is dissolved in 5 ml of acid for atomic-absorption analysis.

Lee [524] described a method for the determination of nanogram or sub-nanogram amounts of nickel in seawater. Dissolved nickel is reduced by sodium borohydride to its elemental form, which combines with carbon monoxide to form nickel carbonyl. The nickel carbonyl is stripped from solution by a helium-carbon monoxide mixed gas stream, collected in a liquid nitrogen trap, and atomised in a quartz tube burner of an atomic absorption spectrophotometer. The sensitivity of the method is 0.05 ng of nickel. The precision for 3 ng nickel is about 4%. No interference by other elements is encountered in this technique.

Between 0.3 and 0.6 $\mu\text{g/l}$ nickel was found by this method, in a vertical profile of water samples taken down to 1200 m in the Santa Catalina Basin.

Nishioka et al. [525] coprecipitated nickel from seawater with sodium diethyldithiocarbamate, filtered, and redissolved the precipitate with nitric acid followed by electrothermal atomic absorption spectrophotography determination of the nickel. The detection limit was 0.5 $\mu\text{g/l}$ and the relative standard deviation was 13.2% at the 2 $\mu\text{g/l}$ level.

5.39.3

Cathodic Stripping Voltammetry

Van den Berg and Nimmo [526] studied the complexation of nickel with dimethylglyoxime in seawater to determine nickel complexing capacities in seawater. Seawater samples were collected from the Menai Streets, Liverpool Bay, and the English Channel and used to test the speciation procedures. The theory for the determination of complexing capacities is presented. Seawater containing 0.01 M borate buffer and 0.0001 M dimethylglyoxime was pipetted into 10–15 separate Teflon voltammetric cells. Nickel was then added to give a concentration range between 1 and 20 nM. After equilibration, cathodic stripping voltammetry was used to determine the labile nickel concentration by measuring the reduction current of nickel-dimethylglyoxime complex absorbed on the hanging mercury drop electrode. Initial concentrations of total dissolved nickel were measured by cathodic stripping voltammetry with 0.0001 M dimethylglyoxime after UV irradiation for 2 h. Values for nickel complexing capacities with dimethylglyoxime were determined for seawater of several salinities by ligand competition with EDTA.

Donat and Bruland [217] determined low levels of nickel and cobalt in seawater by a voltammetric technique, and the nioxime complexes of the two elements were concentrated on a hanging mercury drop electrode. The current resulting from the reduction of Co (II) and Ni (II) was measured by differential pulse cathodic stripping voltammetry. Detection limits are 6 pM (cobalt) and 0.45 nM (nickel).

5.39.4

Liquid Scintillation Counting

To determine ^{63}Ni in seawater the nickel was adsorbed on to hydrous manganese dioxide and the precipitate dissolved in hydrochloric acid. The nickel was then extracted with diethyldithiocarbamate in chloroform and determined by liquid scintillation counting [527].

See also Sects. 5.74.4–5.74.6, and 5.74.8–5.74.17.

5.40

Osmium

5.40.1

Resonance Ionisation Mass Spectrometry

Koide et al. [528, 529] determined osmium in seawater by passing the water down an anion exchange resin column, followed by distillation of the osmium tetroxide and detection by resonance ionization mass spectrometry.

5.41

Palladium

Wang et al. [530] used a liquid membrane containing tri-*N*-octylamine to separate palladium from seawater.

5.42

Platinum

5.42.1

Cathodic Stripping Voltammetry

Platinum was determined in seawater by adsorptive cathodic stripping voltammetry in a method described by Van den Berg and Jacinto [531]. The formazone complex is formed with formaldehyde, hydrazine, and sulfuric acid in the seawater sample. The complex is adsorbed for 20 minutes at -0.925 V on the hanging mercury drop electrode. The detection limit is 0.04 pM platinum.

5.43

Plutonium

See Sect. 7.2.1 and 7.2.7.

5.44 Polonium

See Sect. 7.1.2.

5.45 Potassium

5.45.1 Titration

Potentiometric titration has been applied to the determination of potassium in seawater [532–534]. Torbjoern and Jaguer [533–544] used a potassium selective valinomycin electrode and a computerised semiautomatic titrator. Samples were titrated with standard additions of aqueous potassium so that the potassium to sodium ion ratio increased on addition of the titrant, and the contribution from sodium ions to the membrane potential could be neglected. The initial concentration of potassium ions was then derived by the extrapolation procedure of Gran.

Marquis and Lebel [534] precipitated potassium from seawater or marine sediment pore water using sodium tetraphenylborate, after first removing halogen ions with silver nitrate. Excess tetraphenylborate was then determined by silver nitrate titration using a silver electrode for endpoint detection. The content of potassium in the sample was obtained from the difference between the amount of tetraphenyl boron measured and the amount initially added.

5.45.2 Polarography

Polarography has also been applied to the determination of potassium in seawater [535]. The sample (1 ml) is heated to 70 °C and treated with 0.1 M sodium tetraphenylborate (1 ml). The precipitated potassium tetraphenylborate is filtered off, washed with 1% acetic acid, and dissolved in 5 ml acetone. This solution is treated with 3 ml 0.1 M thallium nitrate and 1.25 ml 2 M sodium hydroxide, and the precipitate of thallium tetraphenylborate is filtered off. The filtrate is made up to 25 ml, and after de-aeration with nitrogen, unconsumed thallium is determined polarographically. There is no interference from 60 mg sodium, 0.2 mg calcium or magnesium, 20 µg barium, or 2.5 µg strontium. Standard deviations at concentrations of 375, 750, and 1125 µg potassium per ml were 26.4, 26.9, and 30.5, respectively. Results agreed with those obtained by flame photometry.

5.45.3

Ion-Selective Electrodes

Ward [536] evaluated various types of potassium ion-selective electrodes for the analysis of seawater. Three types of potassium ion-selective electrodes were evaluated for their suitability for continuous monitoring and in situ measurement applications, in water of varying salinities and at temperatures of 10 °C and 25 °C. The three types comprised a glass-membrane single electrode, a glass-membrane combination electrode, and a liquid-ion exchange electrode. Although all three electrode systems performed well in fresh water, the results obtained with the liquid-ion exchange electrode in seawater were significantly better than those with glass membranes. An accuracy of 5% could be achieved under certain conditions, but response times generally exceeded 10 min, and glass-membrane electrodes were sensitive to external motion and flow variations.

See also Sect. 5.74.4.

5.46

Praseodymium

See Sect. 5.49.2.

5.47

Promethium

See Sect. 5.49.4.

5.48

Radium

See Sect. 7.1.3.

5.49

Rare Earths

These include the following 14 elements: cerium, praseodymium, neodymium, promethium, samarium, europium, gadolinium, terbium, dysprosium, holmium, erbium, thulium, ytterbium, and lutetium.

5.49.1

Cerium

Shigematsu et al. [626] determined cerium fluorometrically at the 1 µg/l level in seawater. Quadrivalent cerium is coprecipitated with ferric hydroxide and

the precipitate is dissolved in hydrochloric acid; interfering ions are removed by extraction with isobutyl methyl ketone. The aqueous phase is evaporated almost to dryness with 70% perchloric acid, then diluted with water and passed through a column of bis-(2-ethylhexyl) phosphate on poly (vinyl chloride), from which Ce^{IV} is eluted with 0.3 M perchloric acid. The eluate is evaporated, then made 7 M in perchloric acid and treated with Ti^{III} , and the resulting Ce^{III} is determined spectrofluorometrically at 350 nm (excitation at 255 nm).

Cerium was included in a list of 14 elements determined by Lee et al. [627] in seawater using neutron activation analysis. The metals were first preconcentrated on a mixture of Chelex 100 and glass powder. The elements were desorbed from the column by 4 M nitric acid, and aqueous solution was irradiated for 3 days and subjected to γ -ray spectrometry method with a Ge(Li) detector coupled to a 4000-channel analyser. Cerium was found to be present to the extent of 16.7 $\mu\text{g/l}$ in water taken from the Kwangyang Bay (South Korea).

For further details see Sect. 5.49.15.

Lieser et al. [628] studied the application of neutron activation analysis to the determination of trace elements in seawater. The rare earths included in this study were cerium and europium. The element concerned were adsorbed onto charcoal. Between 75% and 100% of the elements were adsorbed onto the charcoal which was then subjected to analysis by neutron activation analysis. Cerium (300 $\mu\text{g/l}$) and europium (0.00082 $\mu\text{g/l}$) were found in North Sea water by this method.

For further discussion see Sect. 5.49.15.

5.49.2

Praseodymium

See Sect. 5.49.15.

5.49.3

Neodymium

See Sect. 5.49.15.

5.49.4

Promethium

See Sect. 5.49.15.

5.49.5

Samarium

See Sect. 5.49.15.

5.49.6**Europium**

See Sect. 5.49.15.

5.49.7**Gadolinium**

See Sect. 5.49.15.

5.49.8**Terbium**

See Sect. 5.49.15.

5.49.9**Dysprosium**

See Sect. 5.49.15.

5.49.10**Holmium**

See Sect. 5.49.15.

5.49.11**Erbium**

See Sect. 5.49.15.

5.49.12**Thulium**

See Sect. 5.49.15.

5.49.13**Ytterbium**

See Sect. 5.49.15.

5.49.14**Lutetium**

See Sect. 5.49.15.

5.49.15

Analysis of Rare Earth Mixtures

Elderfield and Greaves [629] have described a method for the mass spectrometric isotope dilution analysis of rare earth elements in seawater. In this method, the rare earth elements are concentrated from seawater by coprecipitation with ferric hydroxide and separated from other elements and into groups for analysis by anion exchange [630–635] using mixed solvents. Results for synthetic mixtures and standards show that the method is accurate and precise to $\pm 1\%$; and blanks are low (e.g., 10^{-12} moles La and 10^{-14} moles Eu). The method has been applied to the determination of nine rare earth elements in a variety of oceanographic samples. Results for North Atlantic Ocean water below the mixed layer are (in 10^{-12} mol/kg) 13.0 La, 16.8 Ce, 12.8 Nd, 2.67 Sm, 0.644 Eu, 3.41 Gd, 4.78 Dy, 407 Er, and 3.55 Yb, with enrichment of rare earth elements in deep ocean water by a factor of 2 for the light rare earth elements, and a factor of 1.3 for the heavy rare earth elements.

Elution volume calibrations were performed using radioactive tracers of the rare earth elements and ^{133}Ba , with atomic-absorption or flame-emission analysis of iron, sodium, potassium, calcium, and magnesium. As shown in Fig. 5.14, any barium added to the second columns is eluted at the start of the “light rare earth element fraction”. To ensure barium removal the sample can be put through the first column again.

Ion exchange chromatography using Chelex 100 resin has been used for the concentration of rare earth elements from large volumes of seawater, with recoveries of 85–112% [636].

The chemistry of rare earth elements makes them particularly useful in studies of marine geochemistry [637]. But the determination of rare earths in seawater at ultratrace levels has always been a difficult task. Of the various methods applied, instrumental neutron activation analysis and isotope dilution mass spectrometry were the main techniques used for the determination of rare earths in seawater. However, sample preparation is tedious and large amounts of water are required in neutron activation analysis. In addition, the method can only offer relatively low sample throughputs and some rare earths cannot be determined. The main drawbacks of isotopic dilution mass spectrometry are that it is time-consuming and expensive, and monoisotopic elements cannot be determined as well.

At present, inductively coupled plasma mass spectrometry provides a unique, powerful alternative for the determination of rare earths in natural samples [638, 639]. Nevertheless, its application to the determination of rare earths at ultratrace concentration level in seawater is limited, because highly saline samples can cause both spectral interferences and matrix effects [640]. Therefore, a separation of the matrix components and preconcentration of the analytes are prerequisites. To achieve this goal, many preconcentration techniques have been used, including coprecipitation with

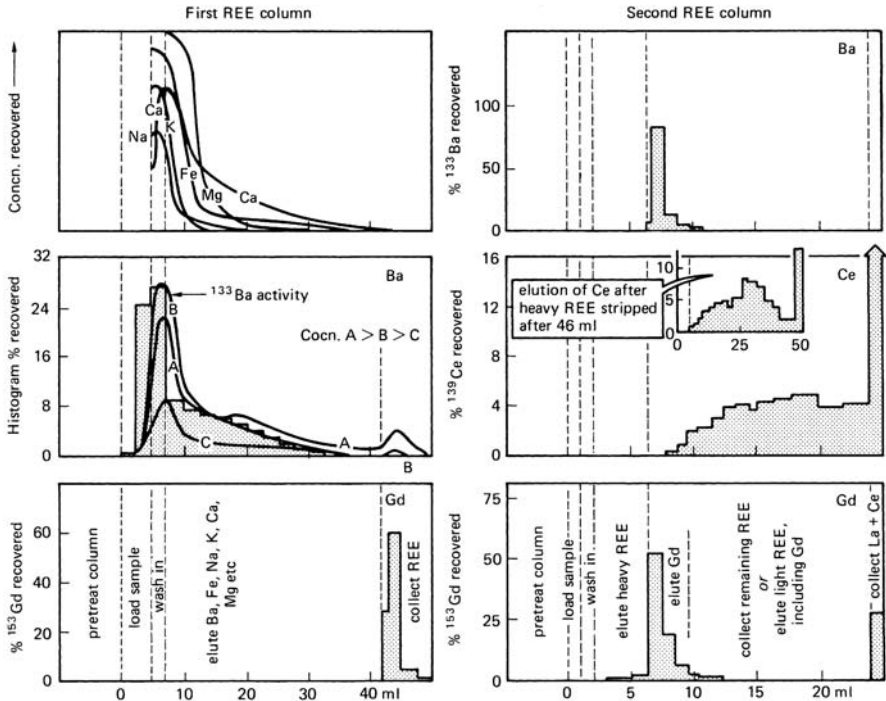

Figure 5.14. Elution curves of the rare earth elements in interfering elements for anion exchange separation using $\text{CH}_3\text{COOH}/\text{HNO}_3$ (1st columns) and MeOH/HNO_3 (2nd columns) mixtures. Source: [629]

iron hydroxide [641–643], ion exchange with Chelex 100 [636, 644–646], treatment with silica-immobilised 8-hydroxyquinoline [647, 648], solvent extraction with bis (2-ethylhexyl) hydrogen phosphate/2-ethylhexyl dihydrogen phosphate [649, 650], and sorption on activated carbon [651]. Coprecipitation with iron hydroxide requires an additional separation step, usually cation exchange chromatography, to remove magnesium, calcium, and iron before determination. Chelation with Chelex 100 requires removal of calcium and magnesium by careful washing with ammonium acetate or by cation and anion exchange chromatography prior to elution of rare earths. The solvent extraction technique reported by Shabani et al. [649, 650] involves many manipulations, such as scrubbing, stripping from the organic phase, washing the aqueous solution, and evaporating the final solution. The concentration technique reported by Esser et al. [647] and Halicz et al. [648] can only concentrate rare earths at pH 8–9, and sorption on activated-carbon [651] is time-consuming.

Tian-Hong Zhang et al. [652] have reported a new ion exchange chelating fibre with aminophosphonic and dithiocarbamate groups, based on polyacrylonitrile for the preconcentration of rare earth elements in seawater prior to their determination by inductively coupled plasma mass spectrometry. Rare

earths can be easily separated from the high-saline matrix using the fibre. The optimum experimental parameters, such as pH, flow rate, sample volume, and effect of matrix ions for preconcentration of rare earths were investigated. All rare earths in water can be quantitatively retained in the acidity range pH 3–6 by the fibre and then eluted quantitatively with 0.01 mol/l ammonium citrate. The fibre has been applied to the concentration of rare earths in seawater. The relative standard deviations for the determination of rare earths in seawater at nanogram per liter levels were found to be less than 5%. Reasonably good agreement is obtained with the data reported in the literature.

Wen et al. [950] used 8-hydroxyquinoline immobilised on a polyarylonitrile hollow fibre membrane to achieve a 300-fold concentration factor for rare earth elements in seawater.

See Sect. 5.74.16.

5.50 Rhenium

Rhenium was one of the last stable elements to be discovered, one of the least abundant metals in the earth's crust, and one of the most important sentinels of reducing aqueous environments through its abundance in sediments. Although its chemistry is fairly well understood, its marine chemistry is as yet poorly developed. In addition, the understanding of rhenium's marine chemistry will provide an entry to the understanding of the marine chemistry of technetium, an element which is just above rhenium in group VIIA (group 7 in 1985 notation) of the periodic table. Technetium has only unstable isotopes, which originate primarily in nuclear weapon detonations and nuclear reactor wastes. These two elements have remarkably similar chemistries. Rhenium's solution chemistry primarily involves anionic species in the IV, V, and VIII oxidation states. The oxo-anion perrhenate is especially stable.

5.50.1 Graphite Furnace Atomic Absorption Spectrometry

Koide et al. [537] have described a graphite furnace atomic absorption method for the determination of rhenium at picomolar levels in seawater and parts-per-billion levels in marine sediments, based upon the isolation of heptavalent rhenium species upon anion exchange resins. All steps are followed with ¹⁸⁶rhenium as a yield tracer. A crucial part of the procedure is the separation of rhenium from molybdenum, which significantly interferes with the graphite furnace detection when the Mo:Re ratio is 2 or greater. The separation is accomplished through an extraction of tetraphenylarsonium perrhenate into chloroform, in which the molybdenum remains in the aqueous phase.

It was observed by these workers that the rhenium signal was attenuated by as little as 10 ng or less of molybdenum in the isolate. Thus, importance is

placed upon molybdenum decontamination steps. In seawaters as well as in many marine sediments the Mo:Re ratio varies by about a factor of 1000. In addition, a clean separation of rhenium from other elements (the salt effect) is required. Otherwise, false peaks result upon atomisation, due to the high background generated by impurities.

The seawater concentration of rhenium is in the range from less than 3 to 11 ng/l, compared to iridium, platinum, and gold, whose concentrations usually do not exceed 0.3 ng/l.

5.50.2

Neutron Activation Analysis

Matthews and Riley [538] have described the following procedure for determining down to 0.06 $\mu\text{g/l}$ rhenium in seawater. From 6 to 8 $\mu\text{g/l}$ rhenium was found in Atlantic seawater. The rhenium in a 15 litre sample of seawater, acidified with hydrochloric acid, is concentrated by adsorption on a column of De-Acidite FF anion exchange resin (Cl^- form), followed by elution with 4 M nitric acid and evaporation of the eluate. The residue (0.2 ml), together with standards and blanks, is irradiated in a thermal neutron flux of at least $3 \times 10^{12} \text{ cm}^{-2} \text{ s}^{-1}$ for at least 50 hours. After a decay period of 2 days, the sample solution and blank are treated with potassium perrhenate as carrier and evaporated to dryness with a slight excess of sodium hydroxide. Each residue is dissolved in 5 M sodium hydroxide. Hydroxylammonium chloride is added to reduce Tc^{VII} , which arises from $^{99\text{m}}\text{Tc}$ from activation of molybdenum present in the samples, and the Re^{VII} is extracted selectively with ethyl methyl ketone. The extracts are evaporated, the residue is dissolved in formic acid:hydrochloric acid (19:1), the rhenium is adsorbed on a column of Dowex 1, and the column is washed with the same acid mixture followed by water and 0.5 M hydrochloric acid; the rhenium is eluted at 0°C with acetone–hydrochloric acid (19:1), and is finally isolated by precipitation as tetraphenylarsonium perrhenate. The precipitate is weighed to determine the chemical yield, and the ^{186}Re activity is counted with an end-window Geiger–Müller tube. The irradiated standards are dissolved in water together with potassium perrhenate. At a level of 0.057 $\mu\text{g/l}$ rhenium, the coefficient of variation was $\pm 7\%$.

5.51

Rubidium

5.51.1

Atomic Absorption Spectrometry

Shen and Li [149] extracted rubidium (and caesium) from brine samples with 4-*tert*-butyl-2-(α -methyl-benzyl) phenol prior to atomic absorption determination of the metal.

5.51.2**Spectrometry**

Schoenfeld and Held [539] used a spectrochemical method to determine rubidium in seawater. They determined concentrations of rubidium in the range 0.008–0.04 $\mu\text{g/ml}$ in the presence of varying proportions and concentrations of other salts as internal standard. The coefficient of variation ranged from 7 to 25% for simulated seawater standards.

5.51.3**Mass Spectrometry**

Isotope dilution mass spectrometry has been used to determine traces of rubidium in seawater [540].

5.51.4**X-ray Fluorescence Spectroscopy**

Rubidium has been determined in seawater by X-ray fluorescence spectrometry with a detection limit of 2–4 μg of rubidium. The rubidium was coprecipitated with $\text{N}_3\text{K}_2[\text{Fe}(\text{CN}_6)]_2$ [541].

See also Sects. 5.74.4, 5.74.9 and 5.74.14.

5.52**Ruthenium**

See Sect. 7.2.8.

5.53**Samarium**

See Sect. 5.49.15.

5.54**Scandium**

See Sect. 5.74.15.

5.55**Selenium**

In recent years, the physiological role of selenium as a trace element has created considerable speculation and some controversy. Selenium has been reported as having carcinogenic as well as toxic properties; other authorities have presented

evidence that selenium is highly beneficial as an essential nutrient [544,545]. Its significance and involvement in the marine biosphere is not known. A review of the marine literature indicates that selenium occurs in seawater as selenite ions (SeO_2^{2-}) with a reported average of $0.2 \mu\text{g/l}$ [543].

5.55.1

Spectrophotometry

Ferric hydroxide coprecipitation techniques are lengthy, two days being needed for a complete precipitation. To speed up this analysis, Tzeng and Zeitlin [595] studied the applicability of an intrinsically rapid technique, namely adsorption colloid flotation. This separation procedure uses a surfactant–collector–inert gas system, in which a charged surface-inactive species is adsorbed on a hydrophobic colloid collector of opposite charge. The colloid with the adsorbed species is floated to the surface with a suitable surfactant and inert gas, and the foam layer is removed manually for analysis by a methylene blue spectrometric procedure. The advantages of the method include a rapid separation, simple equipment, and excellent recoveries. Tzeng and Zeitlin [595] used the flotation unit that was devised by Kim and Zeitlin [517].

Other workers have described spectrophotometric methods [549–554].

5.55.2

Atomic Absorption Spectrometry

Neve et al. [547] digested the sample with nitric acid. After digestion the sample is reacted selectively with an aromatic *o*-diamine, and the reaction product is detected by flameless atomic absorption spectrometry after the addition of nickel (III) ions. The detection limit is 20 mg/l , and both selenium (IV) and total selenium can be determined. There was no significant interference in a saline environment with three times the salinity of seawater.

5.55.3

Hydride Generation Atomic Absorption Spectrometry

Cutter [548] has surveyed the application of this technique to the determination of selenium in seawater.

5.55.4

Cathodic Stripping Voltammetry

Cathodic stripping voltammetry has been used to determine down to 20 ng/l selenium in seawater [542]. The selenium is extracted with 3,3'-diaminobenzidine and concentrated as HgSe on a mercury electrode at -0.45 V .

Certain trace substances such as selenium (IV) can be determined by differential cathodic stripping voltammetry (DPCSV). For selenium a rather positive preconcentration potential of -0.2 V is adjusted. Selenium (IV) is reduced to Se^{2-} , and Hg from the electrode is oxidised to Hg^{2+} at this potential. It forms, with Se^{2-} on the electrode, a layer of insoluble HgSe , and in this manner the preconcentration is achieved. Subsequently the potential is altered in the cathodic direction in the differential pulse mode. The resulting mercury (II) peak produced by the Hg^{II} reduction is proportional to the bulk concentration of Se^{IV} in the analyte.

5.55.5

Gas Chromatography

Measures and Burton [556] used gas chromatography to determine selenite and total selenium in seawater.

Shimoishi [555] determined selenium by gas chromatography with electron capture detection. To 50–100 ml seawater was added 5 ml concentrated hydrochloric acid and 2 ml 4-nitro-*o*-phenylenediamine (1%) and, after 2 hours, the product formed was extracted into 1 ml of toluene. The extract was washed with 2 ml of 7.5 M hydrochloric acid, then a sample (5 μl) was injected into a glass gas-liquid chromatography column (1 m \times 4 mm) packed with 15% of SE-30 on Chromosorb W (60–80 mesh) and operated at 200 °C with nitrogen (53 ml/min) as carrier gas. There is no interference from other substances present in seawater. The detection limit is 5 ng/l with 200 ml samples, and the precision at a Se level of 0.025 $\mu\text{g/l}$ is 6%.

5.55.6

Neutron Activation Analysis

This technique has been applied to the determination of selenium in seawater [603, 604].

See also Sects. 5.74.5, 5.74.7, 5.74.12, 5.74.14, and 5.74.15.

5.56

Silver

5.56.1

Atomic Absorption Spectrometry

Bermejo-Barrera et al. [557] have described an electrothermal atomic absorption spectrometric method for the determination of silver at the ppb level in seawater.

Miller and Bruland [558] have described an equilibration/solvent extraction method based on competition for silver between sample ligands and added

diethyldithiocarbamate for the determination of $\mu\text{g/l}$ levels of silver in seawater. Detection was achieved by graphite furnace atomic absorption spectrometry.

5.56.2

Neutron Activation Analysis

Kawabuchi and Riley [559] used neutron activation analysis to determine silver in seawater. Silver in a 4 l sample of seawater was concentrated by ion exchange on a column (6 cm \times 0.8 cm) containing 2 g of DeAcidite FF-IP resin, previously treated with 50 ml of 0.1 M hydrochloric acid. The silver was eluted with 20 ml of 0.4 M aqueous thiourea and the eluate was evaporated to dryness, transferred to a silica irradiation capsule, heated at 200 °C and ashed at 500 °C. After sealing, the capsule was irradiated for 24 hours in a thermal neutron flux of $3.5 \times 10^{12} \text{ cm}^{-2} \text{ s}^{-1}$, and after a decay period of 2–3 days, the $^{110\text{m}}\text{Ag}$ arising from the reaction $^{199\text{m}}\text{Ag} (n, \gamma) ^{110\text{m}}\text{Ag}$ was separated by a conventional radiochemical procedure. The activity of the $^{110\text{m}}\text{Ag}$ was counted with an end-window Geiger–Müller tube, and the purity of the final precipitate was checked with a Ge(Li) detector coupled to a 4000-channel analyser. The method gave a coefficient of variation of $\pm 10\%$ at a level of 40 ng silver per litre.

See also Sects. 5.74.4, 5.74.14, and 5.74.15.

5.57

Sodium

5.57.1

Amperometry

In the indirect amperometric method [560], saturated uranyl zinc acetate solution is added to the sample containing 0.1–10 mg sodium. The solution is heated for 30 minutes at 100 °C to complete precipitation. The solution is filtered and the precipitate washed several times with 2 ml of the reagent and then five times with 99% ethanol saturated with sodium uranyl zinc acetate. The precipitate is dissolved and diluted to a known volume. To an aliquot containing up to 1.7 mg zinc, 1 M tartaric acid (2–3 ml) and 3 M ammonium acetate (8–10 ml) are added and the pH adjusted to 7.5–8.0 with 2 M aqueous ammonia. The solution is diluted to 25 ml and an equal volume of ethanol added. It is titrated amperometrically with 0.01 M $\text{K}_4\text{Fe}(\text{CN})_6$ using a platinum electrode. Uranium does not interfere with the determination of sodium.

5.57.2

Polarimetry

In the indirect polarimetry method [561] sodium is precipitated as the zinc uranyl acetate salt and the uranium present in the precipitate is determined

polarimetrically after reaction with (+)-tartaric acid. The sample is diluted to contain 0.1–1% (w/v) of sodium. A portion (1–2 ml) is treated with saturated aqueous zinc uranyl acetate (10–20 ml) and the mixture evaporated to the volume of reagent solution added. It is cooled then the precipitate is filtered off and washed with reagent solution and with saturated ethanolic zinc uranyl acetate. The precipitate is dissolved in water, 1 M tartaric acid (15 ml) is added, the pH adjusted to 5 with aqueous sodium hydroxide and diluted to 50 ml. The optical rotation is measured in a 20 cm tube and the sodium content of the sample determined by reference to a calibration graph, which is rectilinear over the range 1.62–16.2 mg sodium per 50 ml. The maximum error was 2.2%.

5.58

Strontium

5.58.1

Atomic Absorption Spectrometry

Carr [562] has studied the effects of salinity on the determination of strontium in seawater by atomic absorption spectrometry using an air–acetylene flame. Using solutions containing 7.5 mg/l strontium and between 5 and 14% sodium chloride, he demonstrated a decrease in absorption with increasing sodium chloride concentration. To overcome this effect a standard additions procedure is recommended.

See also Sects. 5.74.2, 5.74.14, and 5.74.15.

5.59

Technetium

See Sect. 7.1.4.

5.60

Tellurium

5.60.1

Atomic Absorption Spectrometry

Petit [563] has described a method for the determination of tellurium in seawater at picomolar concentrations. Tellurium (VI) was reduced to tellurium (IV) by boiling in 3 M hydrochloric acid. After preconcentration by coprecipitation with magnesium hydroxide, tellurium was reduced to the hydride by sodium borohydrate at 300 °C for 120 seconds, then 257 °C for 12 seconds. The hydride was then measured by atomic absorption spectroscopy. Recovery was 90–95% and the detection limit was 0.5 pmol/l.

Andreae [564] coprecipitated tellurium (V) and tellurium (VI) from seawater and other natural waters with magnesium hydroxide. After dissolution of the precipitate with hydrochloric acid, the tellurium (IV) was reduced to tellurium hydride in 3 M hydrochloric acid. The hydride was trapped inside the graphite tube of a graphite furnace atomic absorption spectrometer, heated to 300 °C, and tellurium (IV) determined. Tellurium (VI) was reduced to tellurium (IV) by boiling with hydrochloric acid and total tellurium determined. Tellurium (VI) was then calculated. The limit of detection was 0.5 pmol per litre and precision 10–20%.

See also Sects. 5.74.5 and 5.74.7.

5.61

Terbium

See Sect. 5.49.15.

5.62

Thallium

See Sect. 5.74.5 and 5.74.8.

5.63

Thorium

5.63.1

Thermal Ion Mass Spectrometry

Moran et al. [565] and Guo et al. [566] have determined $^{230}\text{thorium}$ and $^{232}\text{thorium}$ in seawater using, thermal ion mass spectrometry and secondary ion mass spectrometry, respectively.

See also Sect. 7.1.3.

5.63.2

Neutron Activation Analysis

Huh and Bacon [589] used neutron activation analysis to determine $^{232}\text{thorium}$ in seawater. Seawater samples were subjected to pre- and post-irradiation procedures. Separation and purification of the isotopes, using ion exchange chromatography and solvent extraction, were performed during pre-irradiation. After irradiation $^{233}\text{protactinium}$ was extracted and counted. Yields were monitored with $^{230}\text{thorium}$ and $^{231}\text{protactinium}$ tracers. $^{232}\text{Thorium}$ concentrations were 27×10^{-7} dpm/kg for deep water samples from below 400 m.

See Sect. 5.74.15.

5.64

Thulium

See Sect. 5.49.15.

5.65

Tin

5.65.1

Spectrophotometric Method

In an early method Kodama and Tsubota [567] determined tin in seawater by anion exchange chromatography and spectrophotometry with catechol violet.

After adjusting to 2 mol l^{-1} in hydrochloric acid, 500 ml of the sample is adsorbed on a column of Dowex 1-XS resin (Cl^- form) and elution is then effected with 2 M nitric acid. The solution is evaporated to dryness after adding 1 M hydrochloric acid, and the tin is again adsorbed on the same column. Tin is eluted with 2 M nitric acid, and determined in the eluate by the spectrophotometric catechol violet method. There is no interference from 0.1 mg of aluminium, manganese, nickel, copper, zinc, arsenic, cadmium, bismuth, or uranium; any titanium, zirconium, or antimony are removed by ion exchange. Filtration of the sample through a Millipore filter does not affect the results, which are in agreement with those obtained by neutron activation analysis.

5.65.2

Atomic Absorption Spectrometry

Dogan and Haerdi [568] and Bergerioux and Haerdi [569] determined total tin in seawater by graphite furnace atomic absorption spectrometry. These workers added 0.25 M 1,10-phenanthroline (0.1–1.0 ml) and 0.2 M tetraphenyl boron (0.1–1.0 ml) (both reagents were freshly prepared) to water samples (50–1000 ml) which had been previously filtered through a $0.45 \mu\text{m}$ Millipore filter. The pH of this solution was adjusted to 5.0 before addition of coprecipitating reagents. The precipitate thus obtained was either filtered or centrifuged and dissolved in a 1–5 ml portion of ammoniacal alcohol (methanol, ethanol or *iso*-propanol) solution of $\text{pH} = 8\text{--}9$ or in Lumatom[®]. For large volumes of water, the dissolution of the coprecipitate must be carried out with Lumatom[®], since a precipitate is formed due to other ions present with ammoniacal alcohol solution.

5.65.3

Gas Chromatography

Brinckmann [570] used a gas chromatographic method with or without hydride derivatisation for determining volatile organotin compounds (e.g., tetramethyltin) in seawater. For nonvolatile organotin compounds a direct liquid

chromatographic method was used. This system employs a Tenax GC polymeric sorbent in an automatic purge and trap (P/T) sampler, coupled to a conventional glass column gas chromatograph equipped with a flame photometric detector (FPD). Figure 5.15 is a schematic of the P/T-GC-FPD assembly with typical operating conditions. Flame conditions in the FPD were tuned to permit maximum response to SnH emission in a H-rich plasma, as detected through narrow-bandpass interference filters (610 ± 5 nm) [571]. Two modes of analysis were used: (1) volatile stannanes were trapped directly from sparged 10–50 ml water samples with no pretreatment; and (2) volatilised tin species were trapped from the same or replicate water samples following rapid injection of aqueous excess sodium borohydride solution directly into the P/T sparging vessel immediately prior to beginning the P/T cycle [572].

For either ion exchange resolution of aqueous cations, $R_n\text{Sn}^{(4-n)+}$ aq [573] or their separation as ion pairs, $[R_n\text{Sn}^{(4-n)+} X^{4-n}]^0$, on reverse bonded-phase columns [574] the method is restricted to “free” tin analytes. Unlike the vigorous hydride derivatisation used in the gas chromatography–flame photometric detector method, common high-performance liquid chromatography solvent combinations or their ionic addends will not usually provide sufficient coordination strength to labilise organotin ions strongly bound to solids in environmental samples. Moreover, the high-performance liquid chromatography separations require that injected samples be free of particulates that might clog the column or pumping system.

Brinckmann [570] generated calibration curves by the P/T gas chromatography–FPD method for borohydride reductions of Sn^{IV} , Sn^{II} , and $\text{Me}_2\text{Sn}^{2+}$ species to SnH_4 , SnH_8 , or SnMe_2H_2 , respectively, in distilled water, 0.2 M sodium chloride, and bay water. All three analytes showed a substantial in-

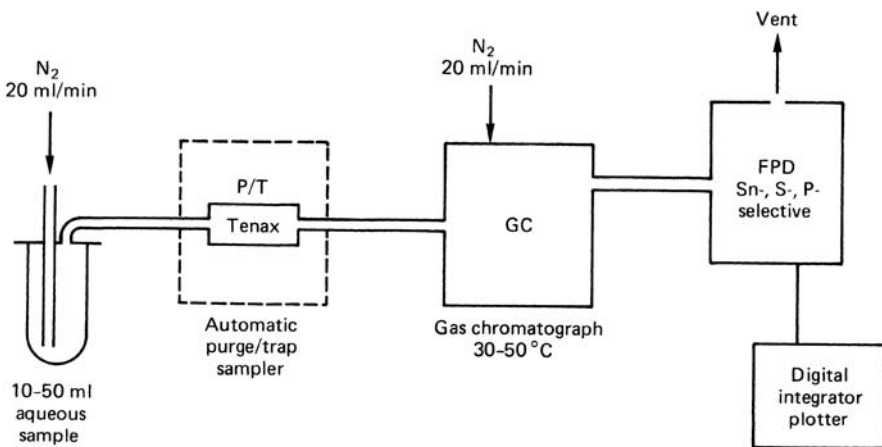
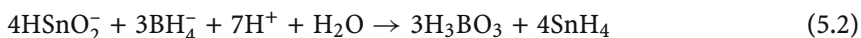

Figure 5.15. The purge/trap GC-FPD system and operating conditions

crease in their calibration slopes in going from distilled water to 0.2 M sodium chloride solution, the latter approximating the salinity and ionic strength common to estuarine waters. Presumably these effects could arise from formation of chlorohydroxy tin species favouring more rapid hydridisation (see (5.1) and (5.2)) [575–577], as well as the more propitious partition coefficients for dynamic gas stripping of the volatile tin hydrides from saline solutions [572]. In typical laboratory distilled water calibration solutions, only 16% of Sn^{II} was recovered as SnH_4 , compared with Sn^{IV} , although this sensitivity ratio can probably be altered somewhat with pH changes [578, 579]. However, in spiking anaerobic pre-purged Chesapeake Bay water with these three tin species, a striking reversal occurred in overall relative sensitivities, i.e., calibration slopes. Brinckmann [570] found that not only was Me_2SnH_2 generation repressed by 50%, but very significantly, SnH_4 formation from Sn^{IV} was reduced by a factor of 15 as compared with the sodium chloride medium.



The overall effect of estuarine water on the hydridisation process is thus one of reducing yields of the three tin species tested. It is expected that not only the dissolved and particulate organics and chloride influence formation of Sn–H bonds, but that other aquated metal ions play an important role, too. Several workers have reported that, for example, As^{III} , As^{V} , Cu^{II} , Co^{II} , Ni^{II} , Hg^{II} , Pb^{II} , and Ag^{I} interfere by unknown means at low concentrations [630, 633].

In summary, the hydride generation method cannot adequately differentiate between aquated Sn^{IV} and Sn^{II} , which may coexist in certain, especially anaerobic, environments found in marine waters. Inorganic tin, speciated as “tin (IV)”, should probably be regarded as “total reducible inorganic tin” until more discriminatory techniques become available [578, 580].

5.65.4

High-Performance Liquid Chromatography

High-performance liquid chromatography, if coupled with a sensitive element-specific detection system such as atomic absorption spectrometry, offers a valuable tool for organotin speciation in complex fluids (especially for high organic loadings) not readily amenable to gas-phase derivatisation methods. In this apparatus the basic high-performance liquid chromatography setup described by Brinckmann [570] is coupled to graphite furnace atomic absorption spectrometry in a manner giving automatic periodic sampling (typically 45 s intervals) of the resolved eluents for tin-specific determination [574]. Injected sample

volumes may vary from 10 to 500 μl . Consequently, system sensitivity is broad and samples can be very representative.

Mixtures of R_3S_n^+ compounds ($\text{R} = n\text{-butyl, phenyl, cyclo-hexyl}$) were separated by ion exchange–high-performance liquid chromatography – graphite furnace atomic absorption spectrometry. The small spread in calibration slopes signifies similar efficiencies for their separation and column recovery, as well as graphite furnace sensitivities. Considerably more sensitivity is possible with P/T-gas chromatography – flame photometric detector speciation of related organotin species known to occur in environmental media [575, 578, 580]. Much greater divergence in the P/T gas chromatography – flame photometric detector system calibration slopes (ratios > 25) is obtained, probably as a result of different rates of hydride derivatisation during the fixed P/T purge time (10 minutes), different partition coefficients affecting the rates at which end species are sparged from the solution [572], or different retentivities on the Tenax GC sorbent [577]. On the basis of the values obtained for the gas chromatographic method with 10 ml sample volumes, nominal working ranges of 10–40 ng/l organotin are feasible.

Both systems are capable of at least a tenfold increase in sensitivity with only minor changes in procedure and equipment. For high-performance liquid chromatography – graphite furnace atomic absorption spectrometry, this can be achieved by both increasing injected sample size and optimising flow rates with a graphite furnace – atomic absorption spectrometry thermal program designed to give maximum atomisation efficiency for a specific organotin analyte [575, 578]. For high-performance liquid chromatography – graphite furnace atomic spectrometry, improvements are realised by adjusting purge flow rate, and time while altering sodium borohydride additions to optimise evolution of given organotin analyte [572]. Also, both increasing the sample volumes [578, 580] and operating the Tenax GC trap at subambient temperatures [581–583] will yield lower working ranges.

5.65.5

Anodic Stripping Voltammetry

A method described by Florence and Farrer [584] separated tin from its associated lead by distillation from an aqueous sulfuric acid medium into which the vapour from boiling 50% hydrobromic acid is passed. The distillate provides an ideal supporting electrolyte for the determination of tin (II) (produced by reduction with hydrazinium hydroxide) by anodic stripping at a rotating vitreous-carbon electrode in the presence of codeposited mercury [585, 586]. The tin is deposited at -0.70 V versus the SCE for 5 minutes, and then stripped at -0.50 V during a sweep from -0.70 V to -0.45 V at 5 V per minute . Tin in seawater is coprecipitated on ferric hydroxide, and the precipitate is then dissolved in the aqueous sulfuric acid, and subjected to the above procedure. The average content for Pacific coastal waters was found to be $0.58\text{ }\mu\text{g/l}$.

5.65.6**Miscellaneous**

Gandon and Guegueniat [587] investigated the recovery of tin from seawater using manganese dioxide and using ^{125}Sr as a tracer. Enrichment factors of 10^3 to 10^5 were found.

Tao et al. [912] preconcentrated tin by derivatisation, followed by gas chromatography – inductively coupled plasma mass spectrometry. Down to 0.00001 ng/l tin could be determined in seawater.

See also Sects. 5.74.5 and 5.74.7.

5.66**Titanium****5.66.1****Spectrophotometric Method**

Yang et al. [588] have described a spectrophotometric method for the determination of dissolved titanium in seawater after preconcentration using sodium diethyldithiocarbamate. See also Sect. 5.74.14.

5.67**Tungsten**

Van den Sloot and Das [502] have described a method for the determination of tungsten in seawater.

5.68**Uranium****5.68.1****Spectrophotometric Method**

Agrawal et al. [590] determined down to 1 ppm of uranium in seawater by liquid extraction with *N*-phenyl-3-styrylacrylohydroxaminic acid followed by spectrophotometry.

5.68.2**Cathodic Stripping Voltammetry**

Van den Berg and Huang [292] determined uranium (VI) in seawater by cathodic stripping voltammetry at pH 6.8 of uranium (VI)-catechol ions. A hanging mercury drop electrode was used. The detection limit was 0.3 nmol/l after

a collection period of 2.5 minutes. Interference by high concentrations of iron (III) was overcome by selective adsorption of the uranium ions at a collection potential near the reduction potential of iron (III). Organic surfactants reduced the peak heights for uranium by up to 75% at high concentrations. EDTA was used to eliminate competition by high concentrations of copper (II) for space on the surface of the drop.

Djogic et al. [591] determined down to 10 nM/l of uranium in seawater using square wave cathodic stripping voltammetry using a similar technique. Economou et al. [592] determined down to 0.1 µg/l of uranium (VI) in seawater.

5.68.3

Polarography

Van den Berg and Nimmo [593] in their determination of uranium in seawater added sample aliquots to the voltammetric cell of a polarograph together with buffer comprising piperazine-*N,N'*-bis (2-ethanesulfonic acid) monosodium salt and sodium hydroxide to give a final buffer concentration of 0.01 M. Oxine solution at 20 µM was also added. The effects of various ligands as chelating agents were investigated to determine the conditions allowing greatest sensitivity. *Trans*-1,2-diaminocyclohexane-*N,N,N',N'*-tetra-acetic acid, 4-2 (2-pyridylazo) resorcinol, gallic acid, benzoin alpha-oxime, nitroso-R-salt, 8-hydroxy-quinoline, and dihydroxyanthraquinone did not give a peak for uranium in seawater at pH 6.9. 1,2-dihydroxybenzene-3,5-disulfonic acid, 3,2-dihydroxybenzoic acid, salicylaldoxime, 1-amino-2-naphthol-4-sulfonic acid, and cupferron did produce a peak for uranium. Best sensitivity for uranium and lack of interferences occurred with 8-hydroxyquinoline. The procedure was not possible for fresh waters because of the poor sensitivity of the comparative method using catechol at low salinities.

5.68.4

Miscellaneous

Spencer [594] has reviewed methods for the determination of uranium in seawater.

Hua et al. [595] have described an automated flow system for the constant-current reduction of uranium (VI) onto a mercury film-coated fibre electrode. Interference from iron (III) was eliminated by addition of sulfite. The results obtained for uranium (VI) in two reference seawater samples, NASS-1 and CASS-1, were 2.90 and 2.68 g/l, with standard deviations of 0.57 and 0.75 g/l, respectively.

See also Sects. 7.2.10, 5.74.9, 5.74.12, 5.74.14–5.74.16.

5.69 Vanadium

5.69.1 Spectrophotometric Method

Nishimura et al. [596] described a spectrophotometric method using 2-pyridyl azoresorcinol for the determination of down to 0.025 µg/l vanadium in seawater. The vanadium was determined as its complex with 4-(2-pyridylazo) resorcinol formed in the presence of 1,2-diaminocyclohexane-*N, N, N', N'*-tetraacetic acid. The complex was extracted into chloroform by coupling with zephiramine. Difficulties due to turbidity in the chloroform layer and incomplete masking of some cations by 2-pyridylazoresorcinol were overcome by addition of potassium cyanide and washing the chloroform layer with sodium chloride solution. The extinction of the chloroform layer was measured at 560 nm against water, as was that of a blank prepared with vanadium-free artificial seawater. Sixteen foreign ions were investigated and no interferences were found at 5–100 times their usual concentration in seawater.

Kiriyama and Kuroda [597] combined ion exchange preconcentration with spectrophotometry using 2-pyridylazoresorcinol in the determination of vanadium in seawater.

The sample (2 litres) diluted to 0.1 M in hydrochloric acid, filtered, and made to 0.1 M in ammonium thiocyanate, is passed through a column of Dowex 1-X8 resin (SCN form). The vanadium is retained and is eluted with concentrated hydrochloric acid. Thiocyanate in the eluate is decomposed by heating with nitric acid, and the solution is evaporated to fuming with sulfuric acid. A solution of the residue is neutralised with aqueous ammonia and evaporated nearly to dryness. The residue is treated with water and aqueous sodium hypobromite, and after 30 min with phenol, phosphate buffer solution of pH 6.5 and aqueous 1,2-diaminocyclohexane-*N, N, N', N'*-tetraacetic acid, and the vanadium is determined spectrophotometrically at 545 nm with 4-(2-pyridylazo) resorcinol. Vanadium was determined in seawater at levels of 1.65 µg/l. After boiling such samples under reflux with potassium permanganate and sulfuric acid (to establish the concentration of organically bound vanadium), values for vanadium were 30–60% higher than corresponding values obtained without oxidation.

5.69.2 Atomic Absorption Spectrometry

Monien and Stangel [598] studied the performance of a number of alternative chelating agents for vanadium, and their effect on vanadium analysis, by atomic absorption spectrometry with volatilisation in a graphite furnace. Two promising compounds were evaluated in detail, namely 4-(2-pyridylazo) resorcinol in conjunction with tetraphenylarsonium chloride and tetramethylenedithiocarbamate. These substances, dissolved in chloroform, were used for extraction

of vanadium from seawater, and after concentrating the organic layer, 5 μl was injected into a pyrolytic graphite furnace coated with lanathanum carbide. For both reagents a linear concentration dependence was obtained between 0.5 and 7 $\mu\text{g/l}$ after extraction from a 100 ml sample.

Using the 2-pyridylazoresorcinol-tetraphenyl-arsonium chloride system a concentration of 1 $\mu\text{g/l}$ could be determined with relative standard deviation of 7%.

5.69.3

Inductively Coupled Plasma Mass Spectrometry

Hastings et al. [599] have described a method for the determination of picogram quantities of vanadium in seawater by isotope dilution inductively coupled plasma mass spectrometry, with electrothermal vaporisation to introduce the sample into the plasma. A ^{50}V isotope spike enriched to 44 atom% was equilibrated with samples, followed by chemical purification by cation exchange chromatography. Samples were introduced into the electrothermal vapourisation unit with a palladium modifier and heated to 1000 $^{\circ}\text{C}$. This quantitatively eliminates the ClO^+ isobaric interference with vanadium at m/z 51 for solutions up to 0.5 M hydrochloric acid. The procedural blank was 0.27 pg of vanadium. Corrections for ^{50}Ti and ^{50}Cr , which interfere with the vanadium signal, were made by measurement of ^{49}Ti and ^{53}Cr . These isobaric interferences and variable ArC levels were the limiting sources of error in the ID measurement, and diminished the detection limit to 6 pg of vanadium. The detection limit for non-isotope dilution applications was 0.3 pg of vanadium in seawater. Accuracy was confirmed by determination of vanadium standards in calcium carbonate, and by comparative measurement with ID thermal ionisation mass spectrometry and graphite furnace atomic absorption spectroscopy.

5.69.4

Cathodic Stripping Voltammetry

Van den Berg and Huang [600] carried out direct electrochemical stripping of dissolved vanadium in seawater using cathodic stripping. Voltammetry was performed with a hanging mercury drop electrode. The detection limit was 0.3 nmol/l after a collection period of 2 min.

Vega and Van den Berg [601] determined vanadium in seawater in amounts down to 70 pM by absorptive stripping voltammetry.

5.69.5

Neutron Activation Analysis

Two methods for the determination of vanadium in seawater have been developed which use neutron activation analysis and atomic absorption spectrometry.

try [602]. The solutions were left for 2–3 hours. These samples (1–3 litres) were passed through a Dowex 1-X8 ion exchange column at a flow rate of 1.7 ml/min. The resin was then washed with 20 ml distilled water, and vanadium eluted with 150 ml eluent solution.

The vanadium eluate was slowly evaporated under an infrared lamp, the residue dissolved in 6 M hydrochloric acid (10 ml) containing 1 ml of the aluminium chloride solution [603], and vanadium was determined by atomic absorption spectrophotometry. For calibration, suitable standard solutions were aspirated before and after each batch of samples.

The average concentration and standard deviation of the Pacific Ocean waters ($\mu\text{g/l}$) were 2.00 ± 0.09 by neutron activation analysis, and 1.86 ± 0.12 by atomic absorption spectrometry. For the Adriatic water the corresponding values were about 1.7 $\mu\text{g/l}$. The difference between the values for the same seawater is within the range to be expected from the standard deviations observed.

Although the neutron activation analysis is inherently more sensitive than the atomic absorption spectrometry, both procedures yield a reliable measurement of vanadium in seawater at the natural levels of concentration.

See also Sects. 5.74.5, 5.74.8, 5.74.9, 5.74.12, and 5.74.14–5.74.17.

5.70 Ytterbium

See Sect. 5.49.15.

5.71 Yttrium

See Sect. 5.74.14.

5.72 Zinc

Zinc has only been measured accurately in open ocean by a few investigators [239, 604–607]. Few data are available because of very low zinc concentrations in seawater and the ubiquitous sources of zinc contamination. The uncertainty of all zinc measurements prior to these investigations, and the paucity of reliable data since, have left little information for the environmental chemist to unravel the biogeochemical behaviour of zinc or to detect waters perturbed by anthropogenic inputs.

Interest in zinc concentrations in the ocean stems from its dual role as a required nanonutrient and as a potential toxicant due to its widespread industrial and marine usage [519, 605]. The major inputs of zinc to surface seawater include atmospheric deposition (both natural and anthropogenic in

origin), fluvial run-off, and upwelled waters. Zinc exists at natural levels in North Pacific surface water at a total concentration of approximately 0.1 nM, increasing to 3 nM at 500 m, and reaching a maximum of ~ 9 nM at depths greater than 2000 m [664]. Our present understanding of the behaviour of zinc in the marine environment is based on only a few vertical profiles. These profiles indicate that zinc is actively incorporated into phytoplankton in surface waters and transported to depth in association with particulate organic matter or passively adsorbed onto particles. There is a high correlation between zinc and dissolved orthosilicic acid which indicates that zinc, like silicate, is regenerated deep in the water column and has a long deep water residence time on the order of 10 000 years [508, 587]. Recent studies indicate that the majority of dissolved zinc in seawater is organically complexed, but the origin and behaviour of the zinc-binding ligands have not been characterized [185, 608].

5.72.1

Spectrofluorometric Method

Nowicki et al. [609] have described a sensitive technique for the shipboard determination of zinc in seawater. The technique couples flow injection analysis with fluorometric detection. A cation exchange column was used to separate zinc from interfering alkali and alkaline earth ions and to concentrate zinc from seawater. The organic indicator ligand, ρ -tosyl-8-aminoquinoline, was used to form a complex with zinc, the fluorescence of which was determined with a flow-through fluorometer. The detection limit (defined as three times the standard deviation of the blank, $n = 4$) was 0.1 nM for a 4.4 ml sample. The precision based on the replicate analysis of samples containing 4.3 nM Zn was $\pm 6\%$ ($n = 5$). A single sample can be analysed in 6 min. The technique was determined to be accurate on the basis of analysis of the standard seawater solutions CASS-2 and NASS-2, and by comparison with previous reliable investigations. A typical profile of 12 samples along with standards and blanks can be completed in triplicate in 5.5 hours.

5.72.2

Atomic Absorption Spectrometry

Graphite furnace atomic absorption spectrometry has also been used to determine zinc [610, 611] in seawater with a detection limit of 2 μg [611]. Guevrement [610] has discussed the use of organic matrix modifiers for the direct determination of zinc.

Dissolved zinc concentrations in seawater have been determined by preconcentration using organic extraction (using APDC/DDDC) or chelating resins (using Chelex 100), followed by graphite furnace atomic absorption spectrometry [122, 612–615] or isotope dilution mass spectrometry [612]. These pro-

cedures must be performed in shore-based ultra-clean laboratories by highly trained personnel.

Huang and Shih [616] used a graphite furnace atomic absorption spectrometer with a stabilised platform furnace involving atomisation from a graphite surface pretreated with vanadium to determine down to 24 ppt of zinc in seawater.

Akatsuka et al. [617] determined down to 2.4 ng/dm^3 of zinc in seawater (500 ml sample) by preconcentration on a column of C_{18} resin coated with methyltricapryl ammonium chloride, followed by graphite furnace atomic absorption spectrometry.

5.72.3

Flow Injection Analysis

A method described by Hirata and Honda [618] uses a flow injection analysis manifold for pH adjustment of a seawater sample, followed by concentration of zinc on a column packed with Chelex 100 resin. The zinc was eluted with nitric acid and determined by atomic absorption spectrometry. The detection limit is $0.5 \text{ } \mu\text{g/l}$ and the relative standard deviation is 2.7% at the $10 \text{ } \mu\text{g/l}$ level.

5.72.4

Stripping Voltammetry

Van den Berg [619] determined zinc complexing capacity in seawater by cathodic stripping voltammetry of zinc–ammonium pyrrolidine dithiocarbamate complex ions. The successful application of cathodic stripping voltammetry, preceded by adsorptive collection of complexes with ammonium pyrrolidine dithiocarbamate for the determination of zinc complexing capability in seawater is described. The reduction peak of zinc was depressed as a result of ligand competition by natural organic material in the sample. Sufficient time was allowed for equilibrium to occur between the natural organic matter and added ammonium pyrrolidine dithiocarbamate. Investigations of electrochemically reversible and irreversible complexes in seawater of several salinities are detailed, together with experimental measurements of ligand concentrations and conditional stability constants for complexing ligands. Results were comparable with those obtained by other equilibrium techniques, but the above method had a greater sensitivity.

Van den Berg [620] also reported a direct determination of sub-nanomolar levels of zinc in seawater by cathodic stripping voltammetry. The ability of ammonium pyrrolidine dithiocarbamate to produce a significant reduction peak in the presence of low concentrations of zinc was used to develop a method capable of achieving levels two orders of magnitude below those achieved with anodic stripping voltammetry. Interference from nickel and cobalt ions could be overcome by using a collection potential of 1.3 V, and interference from

complexing material by ultraviolet irradiation. Zinc could be determined in seawater and fresh water. Zinc and nickel could be determined simultaneously by using dimethylgloxime at a collection potential of -0.7 V, followed by ammonium pyrrolidine dithiocarbamate at -1.3 V. The sensitivity for this determination was 3 pmol/l.

Zima and Van den Berg [621] determined zinc in seawater in amounts down to 3 nmol by cathodic stripping voltammetry.

Muzzarelli and Sipos [622] showed that a column of chitosan (15×10 mm) can be used to concentrate zinc from 3 litres of seawater before determination by anodic-stripping voltammetry with a composite mercury-graphite electrode. Zinc (and lead) are eluted from the column by 2 M ammonium acetate (50 ml), copper by 0.01 M EDTA (10 ml), and cadmium by 0.1 M potassium cyanide (3 ml).

Anodic stripping voltammetry using a tubular mercury-graphite electrode [623] has been employed to determine zinc in seawater. Zinc concentrations of 1×10^9 M can be detected within 5 min using this system.

Analysis of total zinc by anodic stripping voltammetry is problematic because of interference by the hydrogen wave in acidified samples, and due to the inability to detect organically complexed zinc at natural pH values near 8 [185]. An improved understanding of zinc in marine systems now requires rapid, sensitive analytical methods that are less prone to contamination, and that can be performed at sea [624].

5.72.5

Miscellaneous

Adsorption colloid flotation using dodecylamine as surfactant has been used to separate zinc with 95% efficiency from seawater [625].

See also Sects. 5.74.4–5.74.6, 5.74.8–5.74.11, and 5.74.14–5.74.16.

5.73

Zirconium

See Sects. 5.74.14 and 5.74.15.

5.74

Multication Analysis

5.74.1

Titration Procedures

Calcium and Magnesium

Mascini [653] described a potentiometric titration procedure using an Orion Cu^{2+} state electrode for the determination of calcium and magnesium in seawater.

The sample was mixed with an equal volume of borate buffer (pH 9.2). Titration with 0.01 M EDTA gave two breaks corresponding to the concentration of each cation.

Jagner and Kerstein [654, 655] used computer-controlled high-precision complexometric titration for the determination of the total alkaline earth metal concentration in seawater. Total alkaline earths were determined by photometric titration using EDTA with eriochrome Black as indicator. The method yielded $63.32 \mu\text{mole kg}^{-1}$ for the total alkaline earth concentration in standard seawater of 3.5% salinity. The precision was about 0.01%.

5.74.2

Spectrophotometric Procedure

Calcium, Magnesium, and Strontium

Pausch and Margerum [656] have described a differential kinetic method using stopped-flow spectrophotometry.

Atienza et al. [657] reviewed the applications of flow injection analysis coupled to spectrophotometry in the analysis of seawater. The method is based on the differing reaction rates of the metal complexes with 1,2-diaminocyclohexane-*N, N, N', N'*-tetra-acetate at 25 °C. A slight excess of EDTA is added to the sample solution, the pH is adjusted to ensure complete formation of the complexes, and a large excess of 0.3 mM to 6 mM- Pb^{2+} in 0.5 M sodium acetate is then added. The rate of appearance of the Pb^{II} -EDTA complex is followed spectrophotometrically, 3 to 6 stopped-flow reactions being run in succession. Because each of the alkaline-earth-metal complexes reacts at a different rate, variations of the time-scan indicates which ions are present.

5.74.3

Molecular Photoluminescence Spectrometry

Antimony and Arsenic

Tao et al. [658] have described a procedure in which antimony and arsenic were generated as hydrides and irradiated with ultraviolet light. The broad continuous emission bands were observed in the ranges about 240–750 nm and 220–720 nm, and the detection limits were 0.6 ng and 9.0 ng for antimony and arsenic, respectively. Some characteristics of the photoluminescence phenomenon were made clear from spectroscopic observations. The method was successfully applied to the determination of antimony in river water and seawater. The apparatus used in this technique is illustrated in Fig. 5.16.

Negative interferences by transition metal cations such as nickel and copper and nitrite were observed. However, these interferences have also been reported for the hydride generation atomic absorption method, and are due to

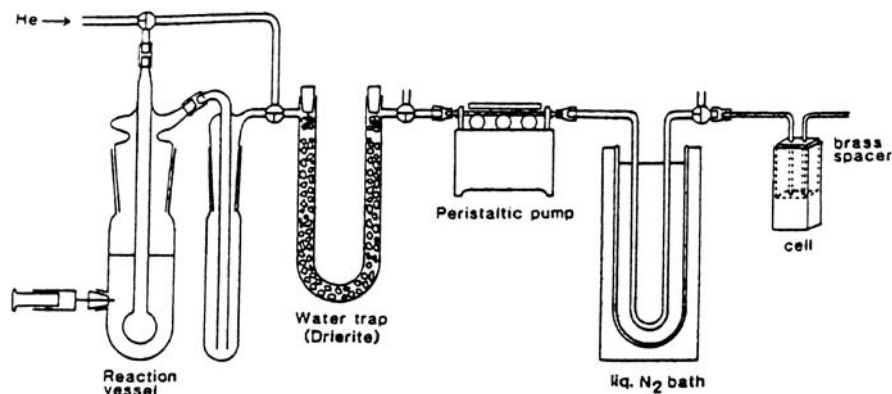

Figure 5.16. Hydride generation system for photoluminescence. Source: [658]

the inhibition of hydride generation. There was no interference from volatile organic compounds. Nitrate enhanced the luminescence signal. Antimony was found to occur in seawater at a level of 0.35 ng/ml.

5.74.4

Flame Atomic Absorption Spectrometry

In general, this technique does not have adequate sensitivity for the determination of the low levels of cations likely to occur in seawater. Coupling the technique with a preconcentration procedure can, however, enable some analyses to be carried out at the $\mu\text{g/l}$ level.

Heavy Metals

(Copper, Zinc, Lead, Cadmium, Iron, Magnesium, Nickel, Cobalt, and Silver)

Armannsson [659] has described a procedure involving dithizone extraction and flame atomic absorption spectrometry for the determination of cadmium, zinc, lead, copper, nickel, cobalt, and silver in seawater. In this procedure 500 ml of seawater taken in a plastic container is exposed to a 1000 W mercury arc lamp for 5–15 h to break down metal organic complexes. The solution is adjusted to pH 8, and 10 ml of 0.2% dithizone in chloroform added. The 10 ml of chloroform is run off and after adjustment to pH 9.5 the aqueous phase is extracted with a further 10 ml of dithizone. The combined extracts are washed with 50 ml of dilute ammonia. To the organic phases is added 50 ml of 0.2 M-hydrochloric acid. The phases are separated and the aqueous portion washed with 5 ml of chloroform. The aqueous portion is evaporated to dryness and the residue dissolved in 5 ml of 2 M hydrochloric acid (solution A). Perchloric acid (3 ml) is added to the organic portion, evaporated to dryness, and a further 2 ml of 60% perchloric acid added to ensure that all organic matter has been

oxidised. After evaporation, the sides of the beaker are washed down with approximately 10 ml of distilled water, evaporated to dryness, and then the residue is taken up in 5 ml of 2 M hydrochloric acid (solution B).

Cadmium is determined at 228.8 nm, zinc at 213.8 nm, and lead at 217.0 nm in solution A. In solution B, copper is determined at 324.7 nm, nickel at 232.0 nm, cobalt at 240.7 nm, and silver at 328.1 nm, all using suitable scale expansion.

Detection limits achieved for the seven metals are between 0.04 $\mu\text{g/l}$ (cobalt and lead) and 0.6 $\mu\text{g/l}$ (zinc).

Olsen et al. [660] used a simple flow injection system, the FIAstar unit, to inject samples of seawater into a flame atomic absorption instrument, allowing the determination of cadmium, lead, copper, and zinc at the parts per million level at a rate of 180–250 samples per hour. Further, online flow injection analysis preconcentration methods were developed using a microcolumn of Chelex 100 resin, allowing the determination of lead at concentrations as low as 10 $\mu\text{g/l}$, and of cadmium and zinc at 1 $\mu\text{g/l}$. The sampling rate was between 30 and 60 samples per hour, and the readout was available within 60–100 seconds after sample injection. The sampling frequency depended on the preconcentration required.

Fang et al. [661] have described a flow injection system with online ion exchange preconcentration on dual columns for the determination of trace amounts of heavy metal at $\mu\text{g/l}$ and sub- $\mu\text{g/l}$ levels by flame atomic absorption spectrometry (Fig. 5.17). The degree of preconcentration ranges from a factor of 50 to 105 for different elements, at a sampling frequency of 60 samples per hour. The detection limits for copper, zinc, lead, and cadmium are 0.07, 0.03, 0.5, and 0.05 $\mu\text{g/l}$, respectively. Relative standard deviations are 1.2–3.2% at $\mu\text{g/l}$ levels. The behaviour of the various chelating exchangers used was studied with respect to their preconcentration characteristics, with special emphasis on interferences encountered in the analysis of seawater.

The flow injection AAS system with online preconcentration will challenge the position of the graphite furnace technique, because it yields comparable sensitivity at much lower cost by using simpler apparatus and separation mode. The method offers unusual advantages when matrices with high salt content (e.g., seawater) are analysed, because the matrix components do not reach the nebuliser.

Cabazon et al. [662] simultaneously separated copper, cadmium, and cobalt from seawater by coflotation with octadecylamine and ferric hydroxide as collectors prior to analysis of these elements by flame atomic absorption spectrometry. The substrates were dissolved in an acidified mixture of ethanol, water, and methyl isobutyl ketone to increase the sensitivity of the determination of these elements by flame atomic absorption spectrophotometry. The results were compared with those of the usual ammonium pyrrolidine dithiocarbamate/methyl isobutyl ketone extraction method. While the mean recoveries were lower, they were nevertheless considered satisfactory.

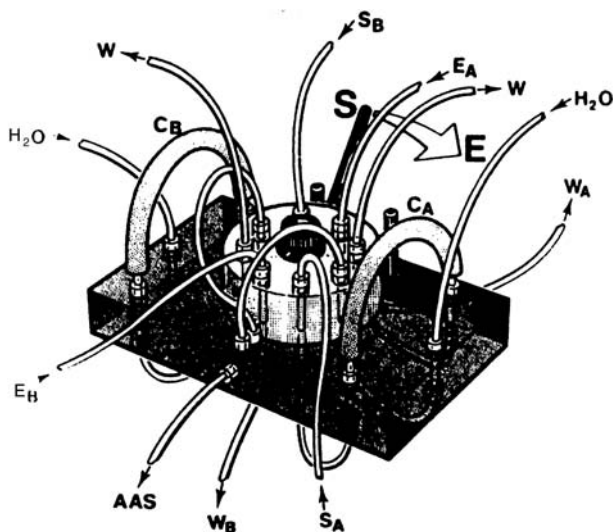

Figure 5.17. Dual-column ion exchange preconcentration valve. S_A , S_B samples A and B; C_A , C_B ion exchange columns A and B; E_A , E_B eluant (2 M nitric acid) for columns A and B; W_A , W_B waste lines for samples and eluants A and B; W waste lines; AAS atomic absorption spectrometer. The dimensions of the base plate of the valve are $70 \times 45 \times 10$ mm. See text for details of operation. Source: [661]

Zhuang et al. [664] used palladium salts as a coprecipitation carrier for the concentration of cadmium, cobalt, and lead in seawater prior to analysis by atomic absorption spectrometry.

Jin [666] used ammonium pyrrolidine dithiocarbamate and electrothermal atomic absorption spectrometry to determine lead, cadmium, copper, cobalt, tin, and molybdenum in seawater.

Rodionova and Ivanov [667] used chelate extraction in the determination of copper, bismuth, lead, cadmium, and zinc in seawater. The metal complexes of diethyl and dithiophosphates are extracted in carbon tetrachloride prior to determination by atomic absorption spectrometry.

Chakraborti et al. [665] determined cadmium, cobalt, copper, iron, nickel, and lead in seawater by chelation with diethyldithiocarbamate from a 500 ml sample, extraction into carbon tetrachloride, evaporation to dryness, and re-dissolution in nitric acid prior to determination by electrothermal atomic absorption spectrometry in amounts ranging from 10 pg (cadmium) to 250 pg (nickel).

Tony et al. [951] have discussed an online preconcentration flame atomic absorption spectrometry method for determining iron, cobalt, nickel, magnesium, and zinc in seawater. A sampling rate of 30 samples per hour was achieved and detection limits were 4.0, 1.0, 1.0, 0.5, and 0.5 $\mu\text{g/l}$, for iron, cobalt, nickel, magnesium, and zinc, respectively.

Silver, Cadmium, Lead, Cobalt, and Nickel

Cimadevilla et al. [691] compared wall, platform, and graphite furnace probe atomisation techniques in electrothermal atomic absorption spectrometry for the determination of $\mu\text{g/l}$ levels of silver, cadmium, and lead in seawater.

Chang et al. [952] used a miniature column packed with a chelating resin and an automatic online preconcentration system for electrothermal atomic absorption spectrometry to determine cadmium, cobalt, and nickel in seawater. Detection limits of 0.12, 7 and 35 ng/l were achieved for cadmium, cobalt, and nickel, respectively, with very small sample volume required (400–1800 μl).

Potassium, Lithium, and Rubidium

Orren [663] used atomic absorption spectrometry to determine these elements in seawater in both their soluble and insoluble forms. The alkali metals are determined directly, but the other elements are first concentrated by solvent extraction. The particulate matter content is derived by dissolving the membranes used to filter the sample and determine the metals in the resulting solution. For organic standards of known metal content, the efficiency of the technique was almost 100%.

5.74.5

Graphite Furnace Atomic Absorption Spectrometry

Heavy Metals

The preponderance of work on multielement analysis in seawaters has been carried out using the graphite furnace technique, as this has the additional sensitivity over the direct technique that is required in seawater analysis.

Theoretical treatments of graphite furnace atomic absorption spectrometry include a study of background signals due to sea salts [668], pyrometric measurement of furnace temperature [669], and methods of introducing the sample into the furnace [670].

Bengtsson et al. [671] found that the high background adsorption of solutions of trace metals containing up to 400 mg/l can be easily minimised by addition of 2% v/v nitric acid. Of the several agents added in an attempt to eliminate the decrease in sensitivity caused by the salt and the variability in sensitivity between graphite tubes, only lanthanum added at 1 g/l was effective for both lead and cadmium.

Campbell and Ottaway [672] have described a simple and rapid method for the determination of cadmium and zinc in seawater, using atomic absorption spectrometry with carbon furnace atomisation. Samples, diluted 1 + 1 with deionised water, are injected into the carbon furnace and atomised in an HGA-72 furnace atomiser under gas-stop conditions. A low atomisation temperature

of 1492 °C is used to separate the atomic absorption signals from background absorption. Detection limits (2 SD) of 0.04 µg/l for cadmium and 1.7 µg/l for zinc are reported. These limits appear to be adequate for all but the cleanest seawater samples. The use of standard additions is essential because of the interference from magnesium chloride, and also when samples of varying salinity have to be analysed.

Lead, cobalt, and nickel have been determined in seawater by atomic absorption spectrometry after electrodeposition on pyrolytic graphite-coated tubes [390]. The tubular, pyrolytic graphite-coated furnace has been incorporated in a flow-through cell for the electrodeposition with mercury of heavy metals from seawater. After plating, the furnace is transferred to an atomic absorption spectrometer for atomisation of the deposited metals. The flow assembly was tested for the analysis of lead in seawater, comparing results with those obtained by anodic stripping voltammetry. The technique is applied to the determination in seawater of both labile and total cobalt and nickel. These metals are irreversibly deposited on graphite and have poor sensitivity using anodic stripping voltammetry, but are readily measured by atomic absorption spectrometry. Measurements are reproducible with a relative standard deviation of 15%. For 15- and 10-minute depositions, copper and nickel characteristic concentrations are 0.02 µg/l.

Stein et al. [673] have described a simplified, sensitive, and rapid method for determining low concentrations of cadmium, lead, and chromium in estuarine waters. To minimise matrix interferences, nitric acid and ammonium nitrate are added for cadmium and lead; only nitric acid is added for chromium. Then 10, 20, or 50 µl of the sample or standard (the amount depending on the sensitivity required) is injected into a heated graphite atomiser, and specific atomic absorbance is measured. Analyte concentrations are calculated from calibration curves for standard solutions in demineralised water for chromium, or an artificial seawater medium for lead and cadmium.

Detection limits (µg/l) were 0.1 for cadmium, 4 for lead, and 0.2 for chromium. The relative standard deviations ($n = 10$) were 20, 9.5, and 18, respectively.

A graphite furnace procedure has been described [674] for the direct determination of iron, chromium, and manganese in seawater and estuarine waters in which the interference normally associated with the presence of sodium chloride is eliminated. The technique requires only very small sample volumes (10–20 µl) for the atomisation stage. The reproducibility of the method was very good. Sensitivities of 0.4, 0.2, and 0.07 µg/l and precisions of determination of 4.5, 3, and 11% (at 2 µg/l level) were obtained for iron, manganese, and zinc.

Montgomery and Peterson [675] showed that ammonium nitrate used as a matrix modifier in seawater analysis to eliminate the interference of sodium chloride degrades the pyrolytic coating on graphite-furnace tubes. The initially enhanced sensitivities for copper, manganese, and iron are maintained for up to 15 atomisations. There is then a rapid decline to a constant lower sensitivity. The characteristics depend strongly on the particular lot of furnace tubes. To

decrease the sodium chloride interference without using a matrix modifier, estuarine samples must be diluted (1 + 1) with pure water. Blanks and standards are prepared and diluted with sample water containing low amounts of trace metals to match the sample matrix.

Iron and manganese have been determined in saline pore water [676] by the following technique.

Pre-acidified pore water (100 μl , diluted with Millipore Q-water if necessary) was transferred, using an Eppendorf pipette, into a 10 ml volumetric Pyrex flask. To this flask nitric acid (50 μl) was added, and the solution was then brought to volume with Millipore Q-water. Standards were made up by adding various amounts to stock metal solutions (1 mg/l), nitric acid (50 μl), and a seawater solution (100 μl) of approximately the same salinity as the samples to be analysed. This final addition ensures that the standards are of approximately the same ionic strength and contain the same salts as the samples.

The samples were analysed by injecting 25 μl aliquots into an HGA 2000 Perkin-Elmer graphite furnace attached to a Jarrell-Ash 82-800 double beam atomic absorption spectrophotometer. Graphite tubes in the furnace were replaced after 75-100 analyses. Metal concentrations were determined by comparing the peak heights of the samples to the standard curve established by the determination of at least five known standards. The detection limits of this technique for 1% absorption were 0.9 $\mu\text{mol/l}$ (Fe), and 0.2 $\mu\text{mol/l}$ (Mn). The coefficient of variation was: $\pm 11\%$ at 6.5 $\mu\text{mol/l}$ for iron and $+12\%$ at 11.8 $\mu\text{mol/l}$ for manganese.

Cadmium, Copper, and Silver

Cadmium, copper, and silver have been determined by an ammonium pyrrolidine dithiocarbamate chelation, followed by a methyl isobutyl ketone extraction of the metal chelate from the aqueous phase [677], and finally followed by graphite furnace atomic absorption spectrometry. The detection limits of this technique for 1% absorption were 0.03 $\mu\text{mol/l}$ (copper), 2 nmol/l (cadmium), and 2 nmol/l (silver).

Yates [678] has discussed the application of graphite furnace atomic absorption spectrometry to the determination of cadmium, copper, lead, nickel, and zinc in filtered saline water samples. He concludes that the determination of these elements is possible with good precision and accuracy by flame or graphite furnace methods after ozonisation and matrix separation on Chelex 100 chelating resin. The limits of detection range between 0.01 $\mu\text{g/l}$ (cadmium) and 50 $\mu\text{g/l}$ (nickel). While application of direct graphite furnace atomic absorption spectrometry (i.e., without Chelex 100 preconcentration) appears to be feasible for the determination of copper and manganese, it does not appear to be so for cadmium and lead, due to a large and variable suppressive interference, and it is concluded that considerable effort would be needed to develop a rapid procedure suitable for routine analysis.

Boyle and Edmond [679] determined copper, nickel, and cadmium in 100 ml of seawater by coprecipitation with cobalt pyrrolidine dithiocarbamate and graphite atomiser atomic absorption spectrometry. Concentration ranges likely to be encountered and estimated analytical precisions (1σ) are 1–6 nmol/kg (± 0.1) for copper, 3–12 nmol/kg (± 0.3) for nickel, and 0.0–1.1 nmol/kg (± 0.1) for cadmium.

Levels of copper, nickel, and cadmium found in the Sargosso Sea were 1.3–4, 4.5–8.2, and 0.31–1.29 nmol/kg, respectively.

Ammonium pyrrolidine dithiocarbamate (APDC) chelate coprecipitation coupled with flameless atomic absorption provides a simple and precise method for the determination of nanomol kg⁻¹ levels of copper, nickel, and cadmium in seawater. With practice, the method is not overly time-consuming. It is reasonable to expect to complete sample concentration in less than 20 min, digestion in about 4 h, and sample preparation in another hour. Atomic absorption time should average about 5 min per element. Excellent results have been obtained on the distribution of nickel and cadmium in the ocean by this technique.

Brugmann et al. [680] compared three methods for the determination of copper, cadmium, lead, nickel, and zinc in North Sea and northeast Atlantic waters. Two methods consisted of atomic absorption spectroscopy but with preconcentration using either freon or methyl isobutyl ketone, and anodic stripping voltammetry was used for cadmium, copper, and lead only. Inexplicable discrepancies were found in almost all cases. The exceptions were the cadmium results by the two atomic absorption spectrometric methods, and the lead results from the freon with atomic absorption spectrometry and anodic scanning voltammetric methods.

The precision of the determinations is generally best using the freon extraction. This is probably because these extractions and determinations were performed under full clean-room conditions. The drawback of acid leaching from containers during long storage is small compared with the advantages gained from working under clean-room conditions.

Bruland et al. [122] have shown that seawater samples collected by a variety of clean sampling techniques yielded consistent results for copper, cadmium, zinc, and nickel, which implies that representative uncontaminated samples were obtained. A dithiocarbamate extraction method coupled with atomic absorption spectrometry and flameless graphite furnace electrothermal atomisation is described which is essentially 100% quantitative for each of the four metals studied, has lower blanks and detection limits, and yields better precision than previously published techniques. A more precise and accurate determination of these metals in seawater at their natural ng/l concentration levels is therefore possible. Samples analysed by this procedure and by concentration on Chelex 100 showed similar results for cadmium and zinc. Both copper and nickel appeared to be inefficiently removed from seawater by Chelex 100. Comparison of the organic extraction results with other pertinent investigations showed excellent agreement.

Figure 5.18 is an absorbance versus time plot obtained by Hoenig and Wollast [681] for the determination of trace metals in seawater. It shows the absorbance profiles of the desired elements as a function of the atomisation temperature. The scale starts with cadmium, for which the absorption signal appears around 400 °C, followed by lead (756 °C), copper (1000 °C), manganese (1200 °C), nickel (1300 °C), and chromium (140 °C).

The time required to completely volatilise the metal increases inversely with the volatility of the element, and is shown by an enlargement of the absorbance peak for the more refractory elements. These element profiles are superimposed with the nonspecific absorption profiles generated by the atomisation of the seawater salts for four preset pyrolysis temperatures. These temperature settings cover the temperature range of pyrolysis for the determination of the indicated elements. Figure 5.18 shows that volatile elements caused the most problems during analysis because of the incomplete removal of the matrix at the required low pyrolysis temperatures. Also, the maximum of the nonspecific absorption profile does not necessarily coincide with the maxima of the analyte signals. As in the case of cadmium, the pyrolysis temperature cannot exceed 380 °C, but at this pyrolysis temperature the background absorbance caused by the seawater matrix becomes excessively high (A profile). However, the temperature at which cadmium appeared (corresponding to the top of the peak) corresponds to the slope of the background (point Y) at approximately 0.8 units of absorbance (0.8 A), which can be easily compensated by a deuterium corrector.

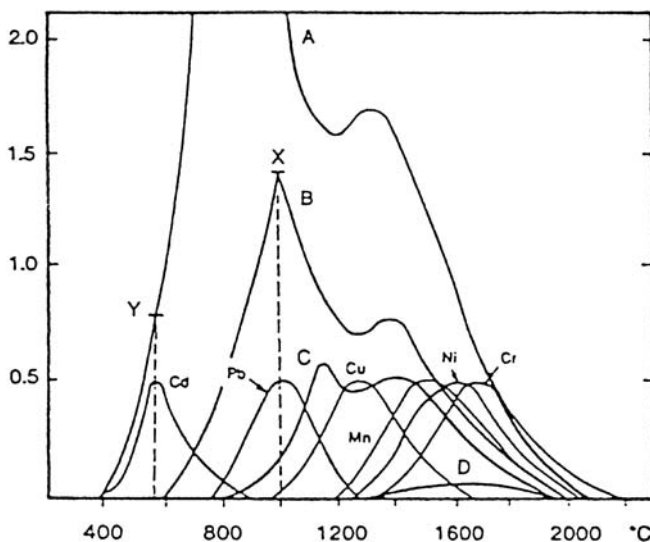

Figure 5.18. Absorbance signals of test elements compared to background absorbance generated by seawater during atomisation for a pyrolysis performed at 380 °C (A), 630 °C (B), 850 °C (C), and 1400 °C (D), in the presence of NH_4NO_3 (4%). Source: [681]

Although the pyrolysis temperature can be raised up to 630 °C to reduce the nonspecific absorption (B profile), the determination of lead is a problem because the appearance temperature of lead corresponds to the maximum absorbance of the matrix signal (point X). Furthermore, the background absorbance of 1.5 A is at the limit of capability of the deuterium arc corrector. This high background, coupled with the poorer sensitivity of lead (compared to that of cadmium), limits the analytical capability of the direct determination of lead in seawater.

The results demonstrate that cadmium can be determined directly; the direct determination of copper, manganese, and chromium is also possible, but their application is more limited than cadmium. The lead and nickel determination proved to be the most difficult, since their determination is limited by their low sensitivity and by the overlap of their absorption profiles with the background absorbance generated by seawater matrix. The direct determination of lead and nickel by this technique can be used only for seawater samples taken in coastal or estuarine zones that are quite polluted.

Furthermore, it is important to emphasise the favourable or unfavourable influence of many analytical and instrumental parameters on the quality of the analysis. It is primarily the state of the graphite tube that can bring about some serious changes regarding magnitude of background during atomisation. Both the configuration and construction of the atomiser play an important role. Background levels can vary considerably depending on the type of furnace used. For example, the background is more elevated in older Instrumentation Laboratory atomisers (Models 455 and 555). In contrast, in newer IL655 atomisers, the reduction of background absorbance is attributed to the flow programming of purge gas during the atomiser cycle. Optimum pyrolysis and atomisation temperatures are so critical to the analysis of seawater that it is necessary to optimise them for the specific equipment being used.

Kingston et al. [129] have described a method for determining cadmium, cobalt, copper, iron, manganese, nickel, lead, and zinc in seawater using Chelex 100 resin and graphite furnace atomic absorption spectrometry. The pH of the seawater is adjusted to 5.0 to 5.5 and then passed through a Chelex 100 resin column. Alkali and alkaline earth metals are eluted from the resin with ammonium acetate and then the trace elements are eluted with two 5 ml portions of 2.5 M nitric acid. The difficulties previously encountered with resin swelling and contraction have been overcome. By careful selection of the instrumental conditions, it is possible to determine subnanogram levels of these trace elements by graphite furnace atomic absorption spectrometry. The method has been shown to separate quantitatively, with greater than 99% recovery, the elements desired from the alkali and alkaline earth metals, and it has been applied in the analysis of trace elements in estuarine water from the Chesapeake Bay and seawater from the Gulf of Alaska.

Abollino et al. [690] compared absorptive cathodic stripping voltammetry and graphite furnace atomic absorption spectrometry in the determination of

cadmium, copper, iron, magnesium, nickel, and zinc in seawater. The effects of UV irradiation and acidification on line preconcentration were studied.

Lead, Magnesium, Vanadium, and Molybdenum

Tominaga et al. [682, 683] studied the effect of ascorbic acid on the response of these metals in seawater obtained by graphite-furnace atomic absorption spectrometry from standpoint of variation of peak times and the sensitivity. Matrix interferences from seawater in the determination of lead, magnesium, vanadium, and molybdenum were suppressed by addition of 10% (w/v) ascorbic acid solution to the sample in the furnace. Matrix effects on the determination of cobalt and copper could not be removed in this way. These workers propose a direct method for the determination of lead, manganese, vanadium, and molybdenum in seawater.

Copper, Iron, Manganese, Cobalt, Nickel, and Vanadium

Segar and Gonzalez [431] carried out a direct determination of these elements in seawater using a graphite atomiser and a deuterium background connector. Sea salts are volatilised at a lower temperature than is required for the volatilisation of the above elements.

Nickel, Copper, Molybdenum, and Manganese

Hayase et al. [684] first extracted the seawater sample with chloroform to remove dissolved organic matter prior to analysis of the aqueous phase by graphite furnace atomic absorption spectrometry. Seawater samples at pH 3 and at pH 8 were extracted with chloroform, evaporated to dryness, and the residue treated with nitric acid. Acid solutions were subjected to metal analyses by graphite furnace atomic absorption spectrometry.

Mercury, Lead, and Cadmium

Tikhomirova et al. [685] developed a procedure for simultaneous concentration of mercury, lead, and cadmium from seawater by coprecipitation with copper sulfide. The isolation yield is 99% for mercury and lead, and 89% for cadmium. Mercury is determined by flameless atomic absorption spectrophotometry, and lead and cadmium by flame atomic absorption spectrophotometry.

Arsenic, Bismuth, Indium, Lead, Antimony, Selenium, Tin, Tellurium, and Thallium

The application of palladium and magnesium nitrate matrix modifier for graphite furnace atomic absorption spectrometry has been discussed in detail [686]. The work has shown that a mixture of palladium and magnesium

nitrate is a powerful matrix modifier for nine elements of Group IIIA through Group VIA of the periodic table. Preliminary results show good promise that this modifier might be used for even more elements, including those of Group IB and Group IIB. This would mean that the palladium and magnesium nitrate modifier could possibly replace almost all the other matrix modifiers recommended up to now, except perhaps for the magnesium nitrate modifier proposed for several transition elements [687]. This would certainly simplify graphite furnace AAS in routine applications.

The palladium and magnesium nitrate modifier makes it possible to apply thermal pretreatment temperatures of at least 900–1000 °C for all investigated elements. For most elements this modifier supports substantially higher pyrolysis temperatures than did the matrix modifier recommended previously by Perkin-Elmer [688]. These higher pyrolysis temperatures allow for effective charring of biological matrices and removal of most inorganic concomitants prior to analyte element volatilisation.

The palladium and magnesium nitrate modifier has a substantial equalising effect on the atomisation temperature of the nine elements investigated. The optimum atomisation temperature for all but one element (thallium) is between 1900 and 2100 °C. This means that all elements can be determined at a “compromise” atomisation temperature of 2100 °C with a minimum sacrifice in sensitivity. Such uniform conditions for as many elements as possible are of vital importance if simultaneous multielement furnace techniques are envisaged. Moreover, in conventional graphite furnace AAS, uniform conditions for a number of elements can greatly facilitate and simplify daily routine analysis.

The mechanism of stabilisation of the palladium and magnesium nitrate modifier was not investigated [749]. It is known, however, that palladium nitrate decomposes via the oxide to the metal at 870 °C, which melts at 1552 °C. The appearance temperature for palladium in a graphite furnace is around 1250 °C. As most of the investigated elements are stabilised to temperatures around 1200 °C, it can be assumed that the modifier acts by imbedding the analyte into the palladium matrix, or even by forming a kind of “alloy” with the analyte.

Platinum and Iridium

Hodge et al. [689] have described a method for the determination of platinum and iridium at picogram levels in marine samples, based upon an isolation of anionic forms of these elements using appropriate resins, with subsequent purification by uptake on a single ion-exchange bead. All steps are followed by radiotracers, and yields vary between 35 and 90%. Graphite furnace AAS was employed as the determinative step.

5.74.6

Zeeman Graphite Furnace Atomic Absorption Spectrometry

The widespread use of graphite furnace systems has greatly expanded the requirements for accurate background correction in atomic absorption measurements. Correction for background absorption is most commonly achieved using continuum sources. While adequate in many cases, the continuum source technique has several inherent limitations. The intensity of the continuum sources is not always adequate; inaccurate correction is possible if the background is structured; plus it is necessary to maintain correct optical alignment between the source and continuum lamps. The combined effect of these limitations means that it is not always possible to obtain accurate correction for applications with high background levels.

The need for improved background correction performance has generated considerable interest in applying the Zeeman effect, where the atomic spectral line is split into several polarised components by the application of a magnetic field. With a Zeeman effect instrument background correction is performed at, or very close to, the analyte wavelength without the need for auxiliary light sources. An additional benefit is that double-beam operation is achieved with a very simple optical system.

In 1971 Hedeishi and McLaughlin [457] first reported the application of the Zeeman effect for the determination of mercury. Numerous workers have since investigated the technique, utilising systems in which the magnetic fields were applied directly to the light source [692–700] or to the atom source [701–704]. There are several possible design approaches for a Zeeman effect atomic absorption spectrophotometer. The magnetic field may be fixed or modulated, the field may be aligned in a direction transverse (perpendicular) or longitudinal (parallel) to the optical path, and the field may be applied to the light source or the atom source.

Pernandez et al. [705], of Perkin-Elmer Limited, reported results obtained in investigating several of these possible design approaches. Background correction performance will probably not be significantly influenced by the position or type of magnet used. However, this is not the case regarding sensitivity and analytical range, where the design employed will have a significant impact on performance. These workers developed a Zeeman effect instrument capable of providing improved background correction performance with minimal sacrifice in analytical sensitivity or working range, and this was incorporated into the Model 5000 instrument. This design utilises a modulated transverse field applied to the graphite tube. Comparisons of analytical sensitivity and working range versus standard atomic absorption performance with the system are reported for the determination of manganese in seawater [452].

Further improvements in the technique [706] includes the use of a L'vov platform to achieve a temperature that is constant in time, and improved pyrolytically coated graphite tubes. To achieve improved performance requires

a fast spectrophotometer, rapid heating of the furnace, integration of the absorbance signals, and usually an appropriate matrix modifier. All of these aspects of the analytical system must be carefully integrated with an understanding of the role played by the system. These workers give guidelines for optimising each part of the system.

In addition to manganese, discussed below [452], the Zeeman technique has been used for the determination of other elements [707] in seawater.

Heavy Metals

De Kersabiec et al. [708] have described a Zeeman method for the determination of copper, lead, cadmium, cobalt, nickel, and strontium in brines and in the soil water adjacent to the Red Sea.

Manganese

To determine manganese [452] several factors had to be controlled carefully to obtain reliable results against simple standards that were independent of salinity and variations in matrix composition. Use of the L'vov platform and integration of the absorbance signal reduced the sensitivity to matrix composition. Pyrolytically coated graphite reduced variations that depend upon the life of the tubes. The tubes appeared to fail by intercalation of the Na or NaCl matrix. The char temperature must not vary outside the range 1100–1300 °C (see below). Zeeman background correction permitted use of larger seawater samples. The detection limit of the procedure using 20 μl samples was 0.1 $\mu\text{g/l}$ (2 pg) manganese. By use of the Zeeman background corrector, less than 0.02 $\mu\text{g/l}$ manganese was detected in seawater using a 75 μl sample.

Chromium, Nickel, Manganese, Cadmium, Arsenic, and Molybdenum

Grobenski et al. [709] have reviewed methodology for the determination of these elements in seawater. Zeeman-effect background correction using an AC magnet around the graphite furnace corrects for nonspecific attenuation up to 2.0 absorbance and corrects for structured background.

Grobenski et al. [709] point out that in analysing different seawater samples under standard temperature platform furnace conditions, one does not always have to deal with such a high background. On the other hand, “over-compensation” using a continuum source background corrector for modest background is usually ascribed to the presence of structured background. In a few cases it is very difficult to distinguish between fast background and structured background.

The following additional, even more important, requirements are put on background correction, namely: there should be no analytical sensitivity loss

associated with correction; accuracy of correction must be very good; and correction of fast background signals should be possible. Normal concentrations for a number of elements in seawater is near or only slightly above the detection limits.

Maximum power heating, the L'vov platform, gas stop, the smallest possible temperature step between thermal pretreatment and atomisation, peak area integration, and matrix modification have been applied in order to eliminate or at least reduce interferences in graphite furnace AAS. With Zeeman effect background correction, much better correction is achieved, making method development and trace metal determinations in samples containing high salt concentrations much simpler or even possible at all.

Molybdenum is an element for which platform atomisation does not offer an advantage. Just the opposite is the case; sensitivity is very poor and memory effects are very strong. The Zeeman detection limit for wall atomisation in a pyrocoated graphite tube using 100 μl of reference solution is 0.03 μl (for both peak height and peak area evaluation) [709].

The molybdenum concentration in the reference sample is rather high and a direct determination using the "cookbook" conditions [710] is very straightforward. There is no difference between peak area and peak height evaluation. In spite of 1800 °C for thermal pretreatment, a small background absorption signal is present.

The experimental value of 11.7 $\mu\text{g/l}$ obtained by this technique is in excellent agreement with the reference value of 11.5 $\mu\text{g/l}$, and the detection limit was 0.04 $\mu\text{g/l}$.

Cabon and Le Bihan [711] studied the effects of transverse heated AAS and longitudinal Zeeman effect background correction in sub $\mu\text{g/l}$ determination of chromium, copper, and manganese in seawater samples.

5.74.7

Hydride Generation Atomic Absorption Spectrometry

Arsenic, Antimony, Bismuth, Selenium, Tellurium, Tin, Lead, and Germanium

A number of elements in the fourth, fifth, and sixth group of the periodic table (Ge, Sn, Pb, As, Sb, Se, Te) form hydrides upon reduction with sodium borohydride, which are stable enough to be of use for chemical analysis. Of these elements, Andreae [712] has investigated in detail arsenic, antimony, germanium, and tin. The inorganic and organometallic hydrides are separated by a type of temperature-programmed gas-chromatography. In most cases it is optimal to combine the functions of the cold trap and the chromatographic column in one device. The hydrides are quantified by a variety of detection systems, which take into account the specific analytical chemical properties of the elements under investigation. For arsenic, excellent detection limits (≈ 40 pg) can be obtained with a quartz tube cuvette burner, which is po-

sitioned in the beam of an atomic absorption spectrophotometer. For some of the methylarsines, similar sensitivity is available with an electron capture detector. The quartz-burner/AAS system has a detection limit of 90 pg for tin; for this element much lower limits (≈ 10 pg) are possible with a flame photometric detection system, which uses the extremely intense emission of the SnH molecule at 609.5 nm. The formation of GeO at the temperatures of the quartz tube furnace makes this device quite insensitive for the determination of germanium. Excellent detection limits (≈ 140 pg) can be reached for this element by the combination of the hydride generation system with a modified graphite furnace/AAS.

The application of these techniques has led to the discovery of a number of organometallic species of arsenic, tin, and antimony in the marine environment. Germanium has not been observed to form organometallic compounds in nature. Some aspects of the geochemical cycles of these elements which have been elucidated by the use of these methods are discussed.

Braman et al. [713] suggested the use of sodium borohydride (NaBH_4) as a reducing agent to replace the metallic zinc used in the classical Marsh test, which is awkward to handle and often contains large blanks of the elements of interest. Sodium borohydride is now used almost exclusively in the various modifications of the hydride method.

Many of the recent methods make use of the condensation of the hydrides in a cold trap at liquid nitrogen temperature. Braman and Foreback [714] pioneered the use of a packed cold trap to serve both as a substrate to collect the hydrides at liquid nitrogen temperature, and to separate arsine and the methylarsines chromatographically by controlled heating of the trap. In the same paper, they described the differentiation between arsenic (III) and arsenic (V) by a prereduction step and by control of the pH at which the reduction takes place. A variety of highly sensitive detectors are used, many of which are element-selective. Most of the detectors commonly used for gas chromatography have been applied to the detection of the hydrides, among them thermal conductivity, flame ionisation, and electron capture detector. A molecular emission detector has been used for tin. Atomic emission spectrometric detectors based on DC discharges [714, 715] and microwave-induced plasmas were applied to the speciation of arsenic in environmental samples. The currently most popular detection system is AAS in one of its numerous variants. The hydrides were at first introduced into a normal AA flame, but it was soon recognised that better detection limits could be achieved with enclosed atom reservoirs and with very small flames or with flameless systems. A number of heated quartz furnace devices without internal flames are now on the commercial market. The lowest detection limits were achieved by cold-trapping of the hydrides and subsequent introduction into either a quartz cuvette furnace [716] or into a commercial graphite furnace [715]. Andreae [712] discusses the methodology of the determination of arsenic, antimony, germanium, and tin with these systems, and its appli-

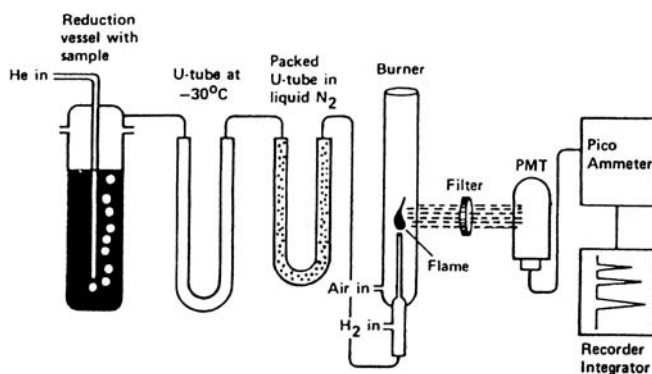

Figure 5.19. Schematic design of the NaBH_4 -reduction/flame photometric detection system for the determination of tin species in natural waters. Source: Author's own files

cation to the investigation of the marine and estuarine chemistry of these elements.

The determination of the hydride element species consists of five steps:

1. Reduction of the element species to the hydrides
2. Removal of interferent volatiles from the gas stream
3. Cold-trapping of the hydrides
4. Separation of the substituted and unsubstituted hydrides from each other and from interfering compounds
5. Quantitative detection of the hydrides

Andreae discusses each of these steps in detail [712]. A typical instrumental configuration to accomplish these steps is shown in Fig. 5.19 for the borohydride reduction/flame photometric detection system for tin speciation analysis.

Reduction of the Element Species to the Hydrides

Most of the hydride elements occur in a number of different species. The optimum reduction conditions vary from element to element, and among different species of the same element, e.g., antimony (III), antimony (V), methylstibonic acid $[(\text{CH}_3)\text{SbO}(\text{OH})_2]$ and dimethylstibinic acid $[(\text{CH}_3)_2\text{SbO}(\text{OH})]$. The conditions under which the element species are being reduced have been optimised as shown in Table 5.5.

With the exception of antimony (V), which requires the presence of iodide for its reduction, all species can be reduced in an acid medium at a pH of 1–2. However, the reduction of some species, including antimony (III), arsenic (III), and all tin species, will also proceed at higher pH, where arsenic (V) and antimony (V) are not converted to their hydrides. This effect permits the selective determination of the various oxidation states of these elements [714, 716]. In the case of tin, reduction can be achieved at the pH of the Tris-HCl

buffer (~6–7), but due to the tin contamination in commercially available Tris-HCl, Andreae [712] prefers to perform the reaction in a medium containing a small amount of nitric acid. This addition results in a solution pH of about 8 after the injection of the NaBH_4 ; without it, the pH would rise above 10 and the reduction to the stannanes would be inhibited. Nitric acid is used, as it is available with a tin blank below the limit of detection (most HCl contains detectable tin blanks). The acid is added to the sample immediately after it has been taken; it then serves both to stabilise the solution and to control the pH of the analytical reaction. Andreae [712] was not able to differentiate between Sn (II) and Sn (IV); both species are reduced with the same yield under his operating conditions.

In contrast to the findings of Foreback [720] and Tompkins [715], Andreae [712] was not able to reduce antimony (V) quantitatively at pH 1.5–2 without the addition of potassium iodide. A concentration of at least 0.15 M KI in the final solution at a pH less than 1.0 was necessary to achieve complete reduction [716]. This is in agreement with the work of Fleming and Ide [717] who suggested an addition of approximately 0.2 M KI per litre to ensure the reduction of Sb (V). Under the conditions used by Foreback [614], Andreae [712] finds only partial reduction of both Sb (III) and Sb (V) (about 30% for both species).

Table 5.5. Reaction conditions for the reduction of various 'hydride element' species to the corresponding hydrides

Species ¹	pKa	pH	Composition of reaction medium	NaBH_4
As(III)	9.2	6–7	0.05 M TRIS-HCl	1
As(V)	2.3	~1	0.12 M HCl	3
MMAA	3.6			
DMAA	6.2			
Sn(II)	9.5	2–8	0.01 M HNO_3	1
Sn(IV)	~10			
Me_xSn	11.7 ¹			
Ge(IV)	9.3	~6	0.095 M TRIS-HCl	3
Sb(III)	11.0	~6	0.095 M TRIS-HCl	2
Sb(V)	2.7	~1	0.18 M HCl, 0.15 M KI	3
MMSA	–	1.5–2.0	0.06 M HCl	2
DMSA	–			

MMAA: monomethylarsonic acid $[(\text{CH}_3)\text{AsO}(\text{OH})_2]$

DMAA: dimethylarsinic acid $[(\text{CH}_3)_2\text{AsO}(\text{OH})]$

Me_xSn : MeSn^{3+} , $\text{Me}_2\text{Sn}^{2+}$, Me_3Sn^+

MMSA: monomethylstibonic acid $[(\text{CH}_3)\text{SbO}(\text{OH})]$

DMSA: dimethylstibonic acid $[(\text{CH}_3)_2\text{SbO}(\text{OH})]$

¹Data available only for $\text{Me}_2\text{Sn}(\text{OH})_2$

From Author's own files

Germanium can be reduced through a wide range of pH [716]. The optimum pH is in the near-neutral range, as the efficiency of germanium reduction decreases at lower pH, probably due to the competitive acid-catalysed hydrolysis of the borohydride ion. At a pH above 8, the yield also decreases, both due to the decrease in reducing power of borohydride with increasing pH, and to the lack of hydrogen evolution at high pH (the hydrogen gas evolving in the solution helps to strip out the hydrides more efficiently than the relatively large helium bubbles passing through the solution).

Removal of Interferent Volatiles from the Gas Stream

Depending on the detector used, some volatile compounds which are formed or released during the hydride generation step may interfere with the detection of the hydrides of interest. Most prominent among them are water, carbon dioxide, and in the case of anoxic water samples, hydrogen sulfide. The atomic absorption detector is insensitive to these compounds, so no precautions need be taken when this detector is used. It has been found convenient in some applications, however, to remove most of the water before it enters the cold-trap/column, which serves to condense and separate the hydrides. This can be accomplished by passing the gas stream through a larger cold trap cooled by a dry ice/alcohol mixture or by an immersion-cooling system [716]. This method was also used with water-sensitive detectors, e.g., the electron-capture detector for methylarsines [716], or with plasma discharge detectors (e.g., Crecelius [718]). Carbon dioxide produces an interfering peak on the plasma discharge detectors and the flame photometric detector for tin. If the separation by the column used is adequate, no additional precautions are necessary to remove carbon dioxide interference. Otherwise, a small tube filled with granulated sodium hydroxide can be included in the gas stream to absorb carbon dioxide. Samples of marine anoxic water often contain large amounts of hydrogen sulfide. This causes a significant interference in a number of different detectors. It can be removed by passing the gas through a tube filled with lead acetate [718].

Cold Trapping of the Hydrides

Only when the very contamination-sensitive electron-capture detector is used is it necessary to provide separate gas streams, one for the reaction and stripping part of the system, the other for the carrier gas stream of the column and detector. Otherwise, the same gas stream can be used to strip the hydrides from solution and carry them into the detector, which greatly simplifies the apparatus. This is of considerable significance, as each additional surface and joint in the apparatus increases the possibility of irreversible adsorption of the sensitive hydrides, and thus is a potential contributor to analytical error. The

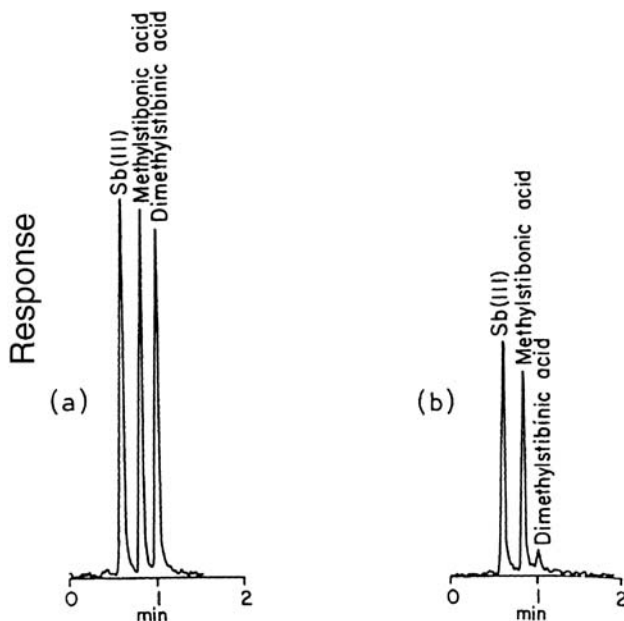

Figure 5.20. **a** Chromatogram of stibine, methylstibine, and dimethylstibine as separated by the OV-3 trap/column with the quartz furnace/AA detector. The stibines were prepared by the NaBH_4 reduction of 2 ng Sb each as Sb (III), methylstibonic, and dimethylstibonic acid. **b** Analysis of a sample of seawater (100 ml) from the open Gulf of Mexico (Station SN4-3-1, 12 March 1981)

cold trap then serves both to collect the hydrides from the reaction gas stream and chromatographically separate them as it is heated up. Initially, column packings of glass beads [614] or glass wool [716] were used. These packings produce poor separation of the methylated species from one another, and badly tailing peaks. Andreae [712] therefore used a standard gas chromatographic packing (15% OV-3 on Chromosorb W/AWDMCS, 60–80 mesh) in U-tubes for the separation of the inorganic and alkyl species of arsenic, antimony, and tin. This packing is quite insensitive to water and produces sharp, well-separated peaks, as demonstrated in Fig. 5.20 for stibine, methylstibine, and dimethylstibine in both standard and seawater samples. The retention times can be regulated by winding a heating wire around the outside of the U-tube and controlling the current supplied to this heating coil.

Quantitative Detection of the Hydrides

Andreae [712] used four different detectors in his investigations: the electron capture detector (for the methylarsines), the quartz cuvette atomic absorption detector (for arsenic and antimony species), the graphite furnace atomic

absorption detector (for germanium and tin species), and the flame photometric detector (for tin species). Their performance in the borohydride analysis system was evaluated.

The electron-capture detector was originally found to be a sensitive detector for the methylarsines [716]. After improvements of the atomic absorption detectors had been made (especially concerning adsorptive losses and peak shapes of the methylarsines), it was found that this detector could be used to replace the electron-capture detector, which because of its lack of specificity and its sensitivity to contamination and changes in operating conditions was very inconvenient to work with.

The most versatile system is the combination of hydride generation with AAS. Here, the objective is to introduce the hydrides into an atom reservoir aligned in the beam of the instrument and to dissociate them to produce a population of the atoms of interest. This can be achieved either in a fuel-rich hydrogen/air flame in a quartz tube (cuvette), as described by Andreae [712], or in a standard graphite furnace by electrothermal atomisation [716]. The quartz cuvette has higher sensitivity than the graphite furnace for arsenic and antimony; it is therefore preferred for the determination of these two elements. When organotin compounds are analysed using the quartz cuvette system, spurious peaks are sometimes seen eluting with the methyltins. The origin of these peaks is not clear. This interference can be avoided by using the graphite furnace system. Here, the hydrides are introduced with the carrier gas stream, to which some argon has been added, into the internal purge inlet of the graphite furnace. They have to pass through the graphite tube and leave through the internal purge outlet. The heating cycle of the furnace is timed so it reaches the required atomisation temperature shortly before the arrival of the unsubstituted hydride, and is held at temperature until the last alkyl-substituted hydride has eluted. With this system, probably due to the higher operating temperature, no spurious tin peaks are present.

The graphite furnace system was originally developed by Andreae [712] when he found that the quartz cuvette gave only very poor sensitivity for germanium. This was attributed to the formation of GeO, a very stable diatomic species, at the relatively low temperatures of the quartz cuvette. At the higher temperatures available with the graphite furnace (2600 °C for the determination of Ge), a sensitivity could be obtained for germanium comparable to that of the other hydride elements.

Nakashima et al. [719] detail a procedure for preliminary concentration of 16 elements from coastal waters and deep seawater, based on their reductive precipitation by sodium tetrahydroborate, prior to determination by graphite-furnace AAS. Results obtained on two reference materials are tabulated. This was a simple, rapid, and accurate technique for determination of a wide range of trace elements, including hydride-forming elements such as arsenic, selenium, tin, bismuth, antimony, and tellurium. The advantages of this procedure over other methods are indicated.

5.74.8

Inductively Coupled Plasma Atomic Emission Spectrometry

The DC plasma was introduced as an excitation source for atomic emission spectrometry by Margoshes and Scribner [721] and Korolev and Vainshtein [722]. Modified designs have been characterised by a number of other authors [614, 719–729]. Commercial equipment is now available from several manufacturers. The principle of the plasma torch arrangement used in these instruments is illustrated in Fig. 5.21 [730].

Winge et al. [730] have investigated the determination of twenty or more trace elements in saline waters by the inductively coupled plasma technique. They give details of experimental procedures, detection limits, and precision and accuracy data. The technique when applied directly to the sample is not sufficiently sensitive for the determination of many of the elements at the low concentrations at which they occur in seawater, and for these samples preconcentration techniques are required. However, it has the advantages of being amenable to automation and capable of analyzing several elements simultaneously.

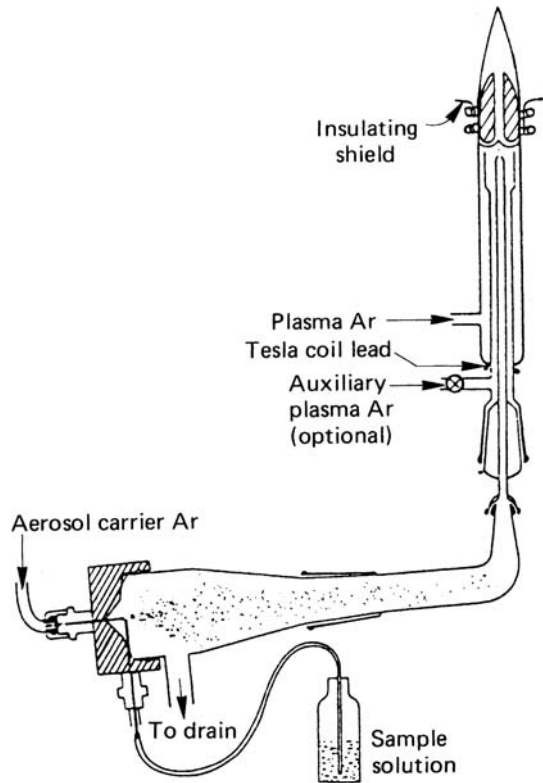

Figure 5.21. Torch and sample aerosol generation system (QVAC 127 system).

Source: [510]

Heavy Metals

The application of the Spectroscan DC plasma emission spectrometer confirmed that for the determination of cadmium, chromium, copper, lead, nickel, and zinc in seawater the method was not sufficiently sensitive, as its detection limits just approach the levels found in seawater [731]. High concentrations of calcium and magnesium increased both the background and elemental line emission intensities.

The extension of inductively coupled plasma (ICP) atomic emission spectrometry to seawater analysis has been slow for two major reasons. The first is that the concentrations of almost all trace metals of interest are $1 \mu\text{g/l}$ or less, below detection limits attainable with conventional pneumatic nebulisation. The second is that the seawater matrix, with some 3.5% dissolved solids, is not compatible with most of the sample introduction systems used with ICP. Thus direct multielemental trace analysis of seawater by ICP-AES is impractical, at least with pneumatic nebulisation. In view of this, a number of alternative strategies can be considered:

1. Preconcentration and removal of the metals of interest from the seawater matrix prior to ICP analysis
2. Use of ultrasonic nebulisation with aerosol desolvation
3. Combination of the foregoing two strategies

Owing to inadequate detection limits by direct analysis, various workers examined preconcentration procedures, including dithiocarbamate preconcentration [447, 732–734], ion exchange preconcentration [735–737], chelation solvent extraction [736], coprecipitation [738], and preconcentration in silica-immobilised 8-hydroxyquinoline [129].

Berman et al. [735] have shown that if a seawater sample is subjected to 20-fold preconcentration by one of the above techniques, then reliable analysis can be performed by ICP-AES (i.e., concentration of the element in seawater is more than five times the detection limit of the method) for iron, manganese, zinc, copper, and nickel. Lead, cobalt, cadmium, chromium, and arsenic are below the detection limit and cannot be determined reliably by ICP-AES. These latter elements would need at least a hundredfold preconcentration before they could be reliably determined.

Berman et al. [735] and McLaren [738] attempted to determine the foregoing nine elements in seawater by a combination of ion exchange preconcentration on Chelex 100 [129, 736–738], and ICP-AES using ultrasonic nebulisation. Preconcentration factors of between 25 and 100 were obtained by this technique.

Table 5.6 compares the ICP-AES results with data generated for the same sample by two other independent methods – isotope dilution spark source mass spectrometry (IDSSMS), and graphite furnace atomic absorption spectrometry (GFAAS). The IDSSMS method also uses 25-fold preconcentration of the metals and matrix separation using the ion exchange procedure, following isotope

Table 5.6. Analysis of Sandy Cove seawater

Element	ICP-AES	GFAAS	IDSSMS
Mn	1.5 ± 0.1	1.4 ± 0.2	1.8 ± 0.2*
Fe	1.5 ± 0.6	1.5 ± 0.1	1.4 ± 0.1
Zn	1.5 ± 0.4	1.9 ± 0.2	1.6 ± 0.1
Cu	0.7 ± 0.2	0.6 ± 0.2	0.7 ± 0.1
Ni	0.4 ± 0.1	0.33 ± 0.08	0.37 ± 0.02
Pb	–	0.22 ± 0.04	0.35 ± 0.03
Cd	–	0.24 ± 0.04	0.28 ± 0.02
Cr	–	–	0.34 ± 0.06
Co	–	–	0.02*

Precision expressed as 95% confidence intervals

* Spark source mass spectrometry, internal standard method

From [735]

addition. The atomic absorption determinations were preceded by an methyl iosbutyl ketone extraction [736]. In general agreement is very good, but one discrepancy merits comment. The spark source mass spectrometry result for manganese is not as reliable as the other data by this method. Since manganese is monoisotopic, a less accurate internal standardisation method of calibration has been used. The ICP–AES result for manganese is in close agreement with the GFAAS result.

Sturgeon et al. [736] compared five different analytical methods in a study of trace metal contents of coastal seawater. Analysis for cadmium, zinc, lead, iron, manganese, copper, nickel, cobalt, and chromium was carried out using isotope dilution spark source mass spectrometry (IDSSMS), graphite furnace atomic absorption spectrometry (GFAAS), and inductively coupled plasma emission spectrometry (ICPES) following trace metal separation preconcentration (using ion exchange and chelation solvent extraction) and direct analysis (by GFAAS).

Table 5.7 gives results obtained on a sample of seawater. Overall, there is good agreement in elemental analysis obtained by the various methods.

Although ICP–AES is a multielement technique, its inferior detection limits relative to GFAAS would necessitate the processing of large volumes of seawater, improvements in the preconcentration procedures in use thus far, or new, alternative preconcentration procedures such as carrier precipitation (see below).

Hiraide et al. [737] developed a multielement preconcentration technique for chromium (III), manganese (II), cobalt, nickel, copper (II), cadmium, and lead in artificial seawater using coprecipitation and flotation with indium hydroxide followed by ICP–AES. The metals are simultaneously coprecipitated with indium hydroxide adjusted to pH 9.5, with sodium hydroxide, ethanolic solutions of sodium oleate and dodecyl sulfate added, and then floated to

Table 5.7. Analysis of seawater sample

Element	Concentration ($\mu\text{g/l}$)			
	GFAAS		ICPES ion exchange	IDSSMS ion exchange
	Direct	Chelation – extraction		
Fe	$1.6 \pm 0.2^*$	1.5 ± 0.1	1.5 ± 0.6	1.4 ± 0.1
Mn	1.6 ± 0.1	1.4 ± 0.2	1.5 ± 0.1	ND
Cd	0.20 ± 0.04	0.24 ± 0.04	ND	0.28 ± 0.02
Zn	1.7 ± 0.2	1.9 ± 0.2	1.5 ± 0.4	1.6 ± 0.1
Cu	ND	0.6 ± 0.2	0.7 ± 0.2	0.7 ± 0.1
Ni	ND	0.33 ± 0.08	0.4 ± 0.1	0.37 ± 0.02
Pb	ND	0.22 ± 0.04	ND	0.35 ± 0.03
Co	ND	$0.018 \pm 0.008^\dagger$	ND	$0.020 \pm 0.003^\ddagger$

*: Precision expressed as standard deviation

† : Pre-concentrated 100-fold by Chelex 100 ion exchange

‡ : Spark source mass spectrometry, internal standard method

From [736]

the solution surface by a stream of nitrogen bubbles. Cadmium may be completely recovered without the coprecipitation of magnesium. Concentrations of the heavy metals chromium (III), manganese (II), cobalt, nickel, copper (II), cadmium, and lead in 1200 ml of artificial seawater were increased 240-fold, while those of sodium and potassium were reduced to 2–5%, and those of magnesium, calcium, and strontium were reduced to 50%.

Down to $1 \mu\text{g/l}$ of the aforementioned heavy metals can be determined by this procedure. However, it is emphasised that real seawater samples were not included in this study.

Heavy Metals and Vanadium

Sugimae [447] developed a method for heavy metals in which they are chelated with diethyldithiocarbamic acid, the chelates are extracted with chloroform, and each chelate decomposed prior to determination. When 1 litre water samples are used, the lowest determinable concentrations are: Mn ($0.063 \mu\text{g/l}$), Zn ($0.13 \mu\text{g/l}$), Cd ($0.25 \mu\text{g/l}$), Fe ($0.25 \mu\text{g/l}$), V ($0.38 \mu\text{g/l}$), Ni ($0.5 \mu\text{g/l}$), Cu ($0.5 \mu\text{g/l}$), and Pb ($2.5 \mu\text{g/l}$). Above these levels the relative standard deviations are better than 12% for the complete procedure.

Heavy Metals, Molybdenum, and Vanadium

Mujazaki et al. [733] found that di-isobutyl ketone is an excellent solvent for the extraction of the 2,4-pyrrolidone dithiocarbamate chelates of these elements from seawater.

Unlike halogenated solvents, it does not produce noxious substances in the inductively coupled plasma, has a very low aqueous solubility, and yields hundredfold concentration in one step. Detection limits ranged from 0.02 $\mu\text{g/l}$ (cadmium) to 0.6 $\mu\text{g/l}$ (lead). The results indicate that the proposed procedure should be useful for the precise determination of metals in oceanic water, although a higher sensitivity would be necessary for lead and cadmium.

A comparison was carried out on the results obtained using ICP–AES and AAS for eight elements in coastal Pacific Ocean water. The results for cadmium, lead, copper, iron, zinc, and nickel are in good agreement. For iron, the data obtained by the solvent extraction ICP method are also in good agreement with those determined directly by ICP–AES. In most of the results the relative standard deviations were 4% for all elements except cadmium and lead, which had relative standard deviations of about 20% owing to the low concentrations determined.

Arsenic, Antimony, and Selenium

De Oliviera et al. [739] have described a technique for determining these elements based on the hydride generation technique. Detection limits are 1 $\mu\text{g/l}$ for arsenic and antimony, and 0.5 $\mu\text{g/l}$ for selenium.

Bismuth, Cadmium, Copper, Cobalt, Indium, Nickel, Lead, Thallium, and Zinc

Berndt et al. [740] have shown that traces of bismuth, cadmium, copper, cobalt, indium, nickel, lead, thallium, and zinc could be separated from samples of seawater, mineral water, and drinking water by complexation with the ammonium salt of pyrrolidine-1-dithiocarboxylic acid, followed by filtration through a filter covered with a layer of active carbon. Sample volumes could range from 100 ml to 10 litres. The elements were dissolved in nitric acid and then determined by atomic absorption or inductively coupled plasma optical emission spectrometry.

5.74.9

Inductively Coupled Plasma Mass Spectrometry

Although the use of inductively coupled plasma mass spectrometry (ICP-MS) is rapidly expanding, because of the many attractive features of this technique, its application to the analysis of saline waters remains limited. This is largely due to the low tolerance of the technique to dissolved solids, with the highest recommended level being 0.2%, if a solution is to be continuously nebulised without inducing undue instrumental drift caused by solid deposition on the orifice. Another restriction comes from effects of concomitant elements that are non-spectroscopic interferences, often resulting in a suppression of analyte signals. Thus, the analysis of seawaters requires a preliminary treatment

in order to reduce their salt content prior to analysis by ICP-MS. This can be accomplished by, for example, preconcentration on silica-immobilised hydroxyquinoline, a technique that allows the concentration of a number of trace metals while separating them from the univalent major ions and, to some extent, the divalent ions such as calcium and magnesium. This technique has been successfully applied to the analysis of the coastal seawater reference material and the open ocean water reference material NASS-2. It presents, however, the disadvantages of being time-consuming and requiring large volumes of sample.

Flow injection analysis can be used to speed up the preconcentration process and reduce sample consumption.

Bloxham et al. [842] have reviewed the application of ICP-MS to the determination of trace metals in seawater.

Heavy Metals

Gee and Bruland [953] used ^{61}Ni , ^{65}Cu , and ^{68}Zn in waters collected in San Francisco Bay to trace the kinetics of nickel, copper, and zinc exchange between dissolved and particulate phases. The technique involved an organic ligand sequential extraction followed by analysis with high-resolution ICP-MS.

A similar approach has been used [954] to examine the partitioning of ^{68}Zn , ^{111}Cd , and ^{207}Pb between seawater and various organic reservoirs in the mussel (*Mytilus galloprovincialis*).

Warnken et al. [956] have reported an online preconcentration – ultrasonic nebulisation – ICP-MS method that achieved detection limits of 0.26, 0.86, 1.5, 10, and 0.44 ng/l for manganese, nickel, copper, zinc, and lead in seawater. This online preconcentration method compares favourably to the state-of-the-art off-line methods.

Liu et al. [955] developed an electrothermal vaporisation isotope dilution – ICP-MS method for determining cadmium, mercury, and lead in seawater at 2, 5, and 1 ng/l detection limits, respectively.

Zinc, Manganese, Cobalt, Copper, Chromium, Nickel, Iron, Cadmium, Lead, and Mercury

Chong et al. [742] have described a multielement analysis of multicomponent metallic electrode deposits, based on scanning electron microscopy with energy dispersive X-ray fluorescence detection, followed by dissolution and ICP-MS detection. Application of the method is described for determination of trace elements in seawater, including the above elements. These elements are simultaneously electrodeposited onto a niobium-wire working electrode at -1.40 V relative to an Ag/AgCl reference electrode, and subjected to energy dispersive X-ray fluorescence spectroscopy analysis. Internal standardisation

is practical for quantitative calibration at the 1 ppm analyte concentration level in an analyte–internal standard concentration ratio range of 0.02–50. Detection limits for energy dispersive X-ray fluorescence spectroscopy range from 1.9 $\mu\text{g/l}$ for iron to 50 $\mu\text{g/l}$ for cadmium. The deposit is dissolved for subsequent ICP-MS determination. Significant reduction in ICP-MS matrix interferences by sodium, calcium, magnesium, potassium, and chloride ions is achieved by deposition at potentials more positive than their very negative reduction potentials. Measurement of elemental isotope ratios is achieved with 0–8% relative error. ICP-MS detection limits for all elements except zinc and iron are superior to those of energy dispersive X-ray fluorescence spectroscopy. Manganese, nickel, cadmium, lead, and mercury can easily be determined over the range 13–86 parts per trillion with ICP-MS.

Copper, Cobalt, Manganese, Nickel, Vanadium, Molybdenum, Cadmium, Lead, and Uranium

Beauchemin and Berman [741] used ICP-MS with online preconcentration, employing a miniature column packed with 8-hydroxy quinoline to determine these elements in open ocean water. This technique improved detection limits of several elements by a factor of 5–7 compared to ICP-MS alone. The online preconcentration system was first assessed by using the method of standard additions to determine manganese, cobalt, nickel, copper, lead, and uranium in the riverine water, SLRS-1, whose salt content was low enough to allow monitoring of both the preconcentration and the solution processes. Results in good agreement with the certified values were obtained for all but nickel because of a spectral interference by calcium oxide from co-eluted calcium. The system was successfully applied to the determination of manganese, molybdenum, cadmium, and uranium in the reference open ocean water, NASS-2, by using an isotope dilution technique and the method of standard additions.

Chapple and Byrne [743] applied an electrothermal vaporisation inductively coupled plasma technique to the determination of copper, cobalt, manganese, nickel, and vanadium in seawater in amounts down to 3–140 ppt.

Heavy Metals, Beryllium, Bismuth, Gallium, Mercury, and Indium

A poly(acrylamino-phosphamic-dithiocarbamate) chelating fibre has been used to preconcentrate several trace metals in seawater by a factor of 200 [957]. The elements included beryllium, bismuth, cobalt, gallium, silver, lead, cadmium, copper, manganese, and indium. ICP-MS was used for detection.

Heavy Metals, Barium

Esser and Volpe [958,959] used a shipboard single-collector quadrupole ICP-MS to survey surface barium and toxic metal levels in seawater.

Heavy Metals, Vanadium

Field et al. [747] used ICP high-resolution mass spectrometry to determine vanadium, chromium, manganese, iron, cobalt, nickel, copper, zinc, cadmium, and lead in seawater. Each analysis required 50 μl sample and a 6 minute analysis time.

Chromium, Copper, Zinc, Cadmium, Lead, Manganese, Iron, Cobalt, Nickel and Vanadium

Field et al. [747] used ICP high resolution mass spectrometry to determine vanadium, chromium, manganese, iron, cobalt, nickel, copper, zinc, cadmium, and lead in seawater. Only 50 μl samples were required in this analysis.

Nickel, Arsenic, and Vanadium

Alves et al. [744] determined vanadium, nickel, and arsenic in seawater in the 10–20 000 ppt range using flow injection cryogenic desolvation ICP-MS.

Beryllium, Aluminium, Zinc, Rubidium, Indium, and Lead

Vandecasteele et al. [745] studied signal suppression in ICP-MS of beryllium, aluminium, zinc, rubidium, indium, and lead in multielement solutions, and in the presence of increasing amounts of sodium chloride (up to 9 g/l). The suppression effects were the same for all of the analyte elements under consideration, and it was therefore possible to use one particular element, $^{115}\text{indium}$, as an internal standard to correct for the suppressive matrix effect, which significantly improved experimental precision. To study the causes of matrix effect, 0.154 M solutions of ammonium chloride, sodium chloride, and caesium chloride were compared. Ammonium chloride exhibited the least suppressive effect, and caesium chloride the most. The results had implications for trace element determinations in seawater (35 g sodium chloride per litre).

Antimony, Arsenic, and Mercury

Stroh and Voellkopf [746] utilised flow injection analysis coupled to ICP-MS to determine down to 0.6 ppt of antimony, arsenic, and mercury in seawater.

Miscellaneous

Mixtures of metals in seawater have been determined [748, 749] online by solid-phase chelation and ICP-MS.

Bettinelli and Spezia [750] applied ion chromatography with an ICP-MS to the determination in seawater of 20 metallic elements in amounts down to 1–50 ppt.

The application of ICP-MS to the determination of metals in seawater have been reviewed by Bloxam et al. [751].

5.74.10

Plasma Emission Spectrometry

Cadmium, Chromium, Copper, Lead, Nickel, and Zinc

Nygaard [752] has evaluated the application of the Spectraspan DC plasma emission spectrometer as an analysis tool for the determination of trace heavy metals in seawater. Sodium, calcium, and magnesium in seawater are shown to increase both the background and elemental line emission intensities. Optimum analytical emission lines and detection limits for seven elements are reported in Table 5.8.

Table 5.8. Optimum analysis wavelengths and detection limits for six trace metals in seawater

Metal	Most intense Emission line (nm)	Detection limit in seawater ($\mu\text{g/l}$)
Cd	228.8	5
Cr	357.9	1
Cu	327.4	2
Pb	405.7	16
Ni	352.5	6
Zn	213.9	3

From [752]

5.74.11

Anodic Stripping Voltammetry

The relative advantages and disadvantages of voltammetric and atomic absorption methodologies are listed below. It is concluded that for laboratories concerned with aquatic chemistry of metals (which includes seawater analysis), instrumentation for both AAS (including potentialities for graphite furnace AAS as well as hydride and cold vapour techniques) and voltammetry should be available. This offers a much better basis for a problem-orientated application of both methods, and provides the important potentiality to compare the data obtained by one method with that obtained in an independent manner by the other, an approach that is now common for the establishment of accuracy in high-quality trace analysis.

Voltammetry

Advantages

Simultaneous analysis for several elements per run

Substance specific

Suitable for speciation studies

3–4 elements per hour

Disadvantages

Prior photolytic decomposition of dissolved organic matter required from many types of sample including seawater

Suspended particulates need prior digestion

Applicable to limited range of metals, e.g., Cu, Pb, Cd, Zn, Ni, Co

Graphite Furnace Atomic Absorption Spectrometry

Advantages

High analysis rate

3–4 elements per hour

Applicable to many more metals than voltammetric methods

Superior to voltammetry for mercury and arsenic particularly in ultratrace range

Disadvantages

Nonspecific absorption

Spectral interferences

Element losses by molecular distillation before atomisation

Limited dynamic range

Contamination sensitivity

Element specific (or one element per run)

Not suitable for speciation studies in seawater

Prior separation of sea salts from metals required

Suspended particulates need prior digestion

About three times as expensive as voltammetric equipment

Inferior to voltammetry for cobalt and nickel

Anodic Stripping Voltammetry

Earlier work on the application of anodic stripping voltammetry to the determination of methods in seawater is reviewed in Table 5.9.

Table 5.9. Metals in seawater – anodic stripping voltammetry

Zn, Cd, Pb, Cu		1 – 10 nm mol/l	[753]
Zn, Cd, Pb, Cu	Zn		[754]
	Pb	0.01 – 0.1 mg/l	
	Cu		
	Cd	0.001 – 0.1 mg/l	[755]
Cd, Pb	Cd	0.18 µg/l	
	Pb	0.21 µg/l	
Bi, Cu, Pb, Cd, Zn		–	[756]
Cu, Pb, Cd, Zn		–	[757]
Tl		0.2 – 1 µmol/l	[758]
Pb, Cd		1 µg/l	[759]
Pb		4 µg/l	[760]

Source: Author's own files

A variety of electrodes have been used in this technique, including rotating mercury coated vitreous carbon [756], wax impregnated graphite cylinders [758], and hanging mercury drops [753–755].

It was the development of the rotating glassy carbon electrode with a pre-plated or co-plated mercury film that gave this technique the sensitivity and resolution required for use in seawater.

Anodic stripping voltammetry using a rotating glassy carbon electrode has been extensively used to study metal organic interactions. The instrumentation is adaptable to use at sea and does not generally require any chemical pretreatment of samples prior to analysis. This permits rapid analysis at in situ pH, thus minimising any changes in speciation due to storage [310, 756–764].

A typical electrode tip consists of a 6 mm glassy carbon disk sealed with Teflon, that had been polished with diamond polishing compound. The reference electrode is an Ag/AgCl type inserted into an acid-cleaned Vycor tip Teflon bridge tube containing clean seawater. High purity argon which is passed through a high-temperature catalytic scrubber to remove oxygen and then is rehumidified using an in-line natural seawater bubbler prior to use is commonly used as a purge gas. Electronic interfaces between the polarograph and the electrode permit the polarograph to control all steps of the analysis automatically, including purging. This sample is placed in an acid-cleaned Teflon polarography cell that has been copiously rinsed with the sample to be analysed. Samples are analysed as quickly as possible after collection at natural pH for free and other easily reducible species, using a pre-plated mercury-film technique.

Because of differing sensitivities and the natural levels of free metal or the anodic scanning voltammetric labile metal, cadmium, and copper in seawater are analysed using a 10 minute plating time, a –1.0 V plating potential, and scanning in 6.67 mV/s increments. Zinc determinations can be made on a fresh aliquot of sample to eliminate any possible effects due to Cu–Zn inter-

metallic complex formation. Zinc is analysed by plating at -1.25 V for 5 min. The remaining operating conditions are the same as described previously for copper and lead. The detection limits of this system were approximately: zinc 0.02 nmol/kg, cadmium 0.02 nmol/kg, and copper 0.3 nmol/kg.

Heavy Metals

Although anodic stripping voltammetry is one of the few techniques suitable for the direct determination of heavy metals in natural waters [310,756–764], it is not readily adaptable to in situ measurements. Lieberman and Zirino [623] examined a continuous flow system for the anodic stripping voltammetry determination of zinc in seawater, using a tubular graphite electrode predeposited with mercury. A limitation of the approach was the need to pump seawater to the measurement cell, while the method required the removal of oxygen with nitrogen before measurements.

Batley and Matousek [390,778] examined the electrodeposition of the irreversibly reduced metals cobalt, nickel, and chromium on graphite tubes for measurement by electrothermal atomisation. This method offered considerable potential for contamination-free preconcentration of heavy metals from seawater. Although only labile metal species will electrodeposit, it is likely that this fraction of the total metal could yet prove to be the most biologically important at the natural pH [779].

Batley [780] examined the techniques available for the in situ electrodeposition of lead and cadmium in seawater. These included anodic scanning voltammetry at a glass carbon thin film electrode and the hanging drop mercury electrode in the presence of oxygen, and in situ electrodeposition on mercury-coated graphite tubes.

Batley [780] found that in situ deposition of lead and cadmium on a mercury-coated tube was the more versatile technique. The mercury film, deposited in the laboratory, is stable on the dried tubes which are used later for field electrodeposition. The deposited metals were then determined by electrothermal AAS.

Scarponi et al. [781] studied the influence of an unwashed membrane filter (Millipore type HA, 47 mm diameter) on the cadmium, lead, and copper concentrations of filtered seawater. Direct simultaneous determination of the metals was achieved at natural pH by linear-sweep anodic stripping voltammetry at a mercury film electrode. These workers recommended that at least 1 litre of seawater be passed through uncleaned filters before aliquots for analysis are taken; the same filter can be reused several times, and only the first 50–100 ml of filtrate need be discarded. Samples could be stored in polyethylene containers at 4°C for three months without contamination, but losses of lead and copper occurred after five months of storage.

Brugmann et al. [782] compared results obtained by ASV and AAS in the determination of cadmium, copper, lead, nickel, and zinc in seawater. Three

methods were compared. Two consisted of AAS but with preconcentration using either freon or methyl isobutyl ketone, and ASV was used for cadmium, copper, and lead only. Inexplicable discrepancies were found in almost all cases. The exceptions were the cadmium results by the two methods and the lead results from the freon with AAS methods and the ASV methods.

Clem and Hodgson [783] discuss the temporal release of traces of cadmium and lead in bay water from EDTA, ammonium pyrrolidine diethyldithiocarbamate, humic acid, and tannic acid after treatment of the sample with ozone. Anodic scanning voltammetry was used to determine these elements.

Nygaard et al. [752] compared two methods for the determination of cadmium, lead, and copper in seawater. One method employs anodic stripping voltammetry at controlled pH (8.1, 5.3 and 2.0); the other involves sample pretreatment with Chelex 100 resin before ASV analysis. Differences in the results are discussed in terms of the definition of available metal and differences in the analytical methods.

Decreasing the pH makes more metal available to the electrode during the plating period. The metals are apparently made available through a number of processes:

- (1) Protonation of inorganic complexing anions such as carbonate, bicarbonate, sulfate, and hydroxide
- (2) Dissolution of gelatinous hydrous iron oxide, which adsorbs and occludes metals
- (3) Protonation of organic complexing agents

Brugmann [784] discussed different approaches to trace metal speciation (bioassays, computer modelling, analytical methods). The electrochemical techniques include conventional polarography, ASV, and potentiometry. ASV diagnosis of seawater was useful for investigating the properties of metal complexes in seawater. Differences in the lead and copper values yielded for Baltic seawater by methods based on differential pulse ASV or AAS are discussed with respect to speciation.

Bruland et al. [785] compared voltammetric and AAS (with preconcentration) methods in the determination of copper, lead, and cadmium in seawater.

Cyclohexane-1,2-dione dioxime (nioxime) complexes of cobalt (II) and nickel (II) were concentrated from 10 ml seawater samples onto a hanging mercury drop electrode by controlled adsorption. Cobalt (II) and nickel (II) reduction currents were measured by differential pulse cathodic stripping voltammetry. Detection limits for cobalt and nickel were 6 pM and 0.45 mM, respectively. The results of detailed studies for optimising the analytical parameters, namely nioxime and buffer concentrations, pH, and adsorption potential are discussed.

Achterberg, Van den Berg, and others [786] used a voltammetric technique to take continuous real-time measurements of nickel, copper, and zinc in the Irish Sea.

Cuculic and Branica [788] used differential pulse ASV to study the adsorption of cadmium, lead, and copper on glass, quartz, and Nalgene sample containers. Nalgene was shown to be the best for sample storage, and quartz the best for electroanalytical vessels.

Bond et al. [791] studied strategies for trace metal determination in seawater by ASV using a computerised multi-time domain measurement method. A microcomputer-based system allowed the reliability of the determination of trace amounts of metals to be estimated. Peak height, width, and potential were measured as a function of time and concentration to construct the database. Measurements were made with a potentiostat polarographic analyser connected to the microcomputer and a hanging drop mercury electrode. The presence of surfactants, which presented a matrix problem, was detected via time domain dependent results and nonlinearity of the calibration. A decision to pretreat the samples could then be made. In the presence of surfactants, neither a direct calibration mode nor a linear standard addition method yielded precise data. Alternative ways to eliminate the interferences based either on theoretical considerations or destruction of the matrix needed to be considered.

Cadmium, Copper, Lead, Antimony, and Bismuth

Brihayé et al. [787] have described a procedure for the determination of these elements in seawater.

Results obtained for cadmium, lead, copper, antimony, and bismuth in seawater by two different methods (linear ASV with a ring-disk electrode and differential pulse anodic scanning voltammetry with a hanging mercury drop electrode) were in good agreement for UV-irradiated samples. Linear anodic scanning voltammetry with the ring-disk electrode gave systematically higher cadmium, lead, and copper contents because of exchange of mercury (II) ions added to the solution, with the heavy metal non-labile complexes.

Copper and Mercury

Sipos et al. [789] have described a procedure for the simultaneous determination of copper and mercury in seawater down to the ng/l range using differential pulse ASV at a gold electrode. Pretreatment is necessary, and comprises UV irradiation to release the trace metal bound to dissolved organic matter.

A relative standard deviation of 2.7% was obtained for copper at the 0.35 $\mu\text{g}/\text{kg}$ level, and 18.6% at the 0.026 $\mu\text{g}/\text{kg}$ for mercury.

Miscellaneous

Bott [790] reviewed of voltammetric methods for the determination of trace metals in seawater and other natural waters.

Nurnberg [792] has studied in great detail various aspects which are important to obtaining reliable results by voltammetric methods. These include

sampling, sample pretreatment steps, optimum pH adjustment, sample storage, decomposition of dissolved organic matter, the voltammetric determination, digestion of filtered-off suspended matter and automation. These details are extremely interesting for anyone who is considering setting up voltammetric methods in their laboratory. Nurnberg [792] also discusses results obtained by these techniques on seawater samples from the Mediterranean and Belgian, Dutch, and German coastal zones of the North Sea, Norwegian Sea and North Atlantic, the Pacific, the Arctic Oceans, and the Weddell Sea.

Differential Pulse Anodic Stripping Voltammetry

Duinker and Kramer [311] studied the speciation of dissolved zinc, cadmium, lead, and copper in North Sea water by differential pulse ASV.

Dissolved electroactive concentrations of zinc, cadmium, lead, and copper in the North Sea samples were measured at natural and lower pH values by this technique using a Kemula-type hanging mercury drop.

Studies with spiked seawater showed that low concentrations of cadmium and lead could be measured in the presence of oxygen by using differential pulse ASV at the hanging mercury drop electrode [780]. The presence of oxygen resulted in a highly sloping baseline giving rise to greater analytical errors. In samples buffered to pH 4.8, peak heights and peak potentials did not differ significantly before and after oxygen removal. For samples at the natural pH of 7.8, although the cadmium wave was unchanged, the lead wave in the presence of oxygen was greater in height by 21% and shifted by 15 mV to a more negative potential.

At the glassy carbon electrode, using both in situ and preformed mercury films, similar results were obtained, but the sloping baseline interference observed at the hanging mercury drop electrode was less evident because of the higher stripping currents.

The in situ electrodeposition technique was applied to the determination of lead in saline waters of the Port Hacking Estuary near Sydney. Graphite tubes precoated with mercury were used in the immersible Perspex electrode probe. For natural lead concentrations, depositions in excess of 15 minutes were required to give absorbance values greater than 0.1 during atomisation. Blank values for the coated-tubes were low, but increased for tubes immersed in the sampled water at a controlled potential below that required for lead deposition (-0.3 V versus Ag/AgCl), for deposition times similar to those used for lead determinations. Results for lead showed good agreement with those for labile lead determined independently by stripping voltammetry.

The limits of detection for metals in seawater using in situ graphite tube electrodeposition will be governed by the deposition time. Unlike laboratory analyses, there will be no depletion of metals from the solution when lengthy deposition times are used, since fresh sample is being continuously pumped through the electrode. It should therefore be possible to detect the extremely

low metal concentrations in open ocean water. For lead it was found, for example, that a 2 h deposition in the presence of oxygen gave a measured lead atomisation absorbance equivalent to twice the blank value, for seawater containing 10 ng Pb per litre.

Average concentrations detected in North Sea samples at salinities $\geq 32\%$ S and their ranges are (in $\mu\text{g/l}$): 3.9 (2.0–7.5) for zinc, 0.23 (0.13–0.31) for cadmium, 0.3 (0.1–0.6) for lead, and 0.3 (0.25–0.60) for copper (pH 8.1). The ammonium pyrrolidine dithiocarbamate methylisobutyl ketone extraction/concentration method, followed by AAS measurement applied to the same samples, resulted in concentrations (in $\mu\text{g/l}$) of 3.9 (2.0–7.5) for zinc, 0.11 (0.01–0.27) for cadmium, 0.5 (0.2–0.9) for lead, and 1.6 (0.7–3.2) for copper. A fraction of the electroactive concentrations at pH 2.7 (6.1 for zinc) are electroactive at pH 8.1. The fractions are 100% for cadmium, 20% for copper, 13% for lead, and 40% for zinc. The remaining fractions are partly composed of organically bound species in solution. The low value for lead may result from the presence of particulate lead dissolved at low pH.

North Sea water at the natural pH has a complexing capacity, probably due to the presence of dissolved organic compounds, in a concentration equivalent to 0.3 M copper. The complexing capacity is zero at pH 2.7. The method of standard addition for the determination of electroactive copper and lead concentrations may lead to erroneous results in samples where complexation of this type occurs.

Cuculic and Branica [788] applied differential pulse anodic stripping voltammetry to a study of the adsorption of cadmium, copper, and lead in seawater onto electrochemical glass vessels, quartz cells, and Nalgene sample bottles. Nalgene was best for sample storage and quartz was best for electroanalytical vessels.

For most tasks in the trace chemistry of natural waters, voltammetric determination requires preconcentration, because in a group of simultaneously determined ecotoxic heavy metals one usually has levels below $0.1 \mu\text{g/l}$.

Electrochemical preconcentration can be achieved in the following two different ways, depending on whether differential pulse stripping voltammetry (differential pulse ASV) or adsorption differential pulse voltammetry has been applied.

Heavy metals capable of forming amalgams, e.g., Cu, Pb, Cd, Zn, etc., are plated at a stationary mercury electrode consisting of a hanging mercury drop electrode with adjustment of a rather negative potential of -1.2 V versus the Ag/AgCl reference electrode for several minutes. To speed up mass transfer, the solution is stirred with a magnetic bar at 900 rpm. Their preconcentration is achieved by the accumulation of the heavy plated metals in the mercury drop. Subsequently the stirring is terminated, and after a quiescent period of 30 seconds the potential is scanned in the anodic direction in differential pulse mode. At the respective redox potential the plated heavy metal is reoxidised and the corresponding current is recorded (Fig. 5.22). The voltammetric peak

heights obtained are proportional to the bulk concentrations of the respective trace metals in the analyte.

The hanging drop mercury electrode can usually be applied down to trace levels of 0.1–0.05 $\mu\text{g/l}$.

At lower ultratrace levels, the less voluminous mercury film electrode has to be used. It consists of a mercury film of only several hundred nm thickness on a glassy carbon electrode as support. The fabrication of this glassy carbon electrode is critical for obtaining an optimal mercury film electrode suitable to perform determinations down 1 ng/l or below.

Turner et al. [331] showed that rapid staircase stripping at 1–2 ms step widths provides a fast sensitive alternative to differential pulse stripping for field use, particularly in the automated determination of copper.

Mart et al. [793] and Valenta et al. [794] have described two differential pulse ASV methods for the determination of cadmium, lead, and copper in arctic seawater. After a previous plating of the trace metals into a mercury film on a rotating electrode with a highly polished glassy carbon as substrate, they were stripped in the differential pulse mode. The plating was done in situ.

The film formed during the blank test was left on the glassy carbon surface. Upon addition of further mercury nitrate, 20–50 μl of a 5 g/l solution were

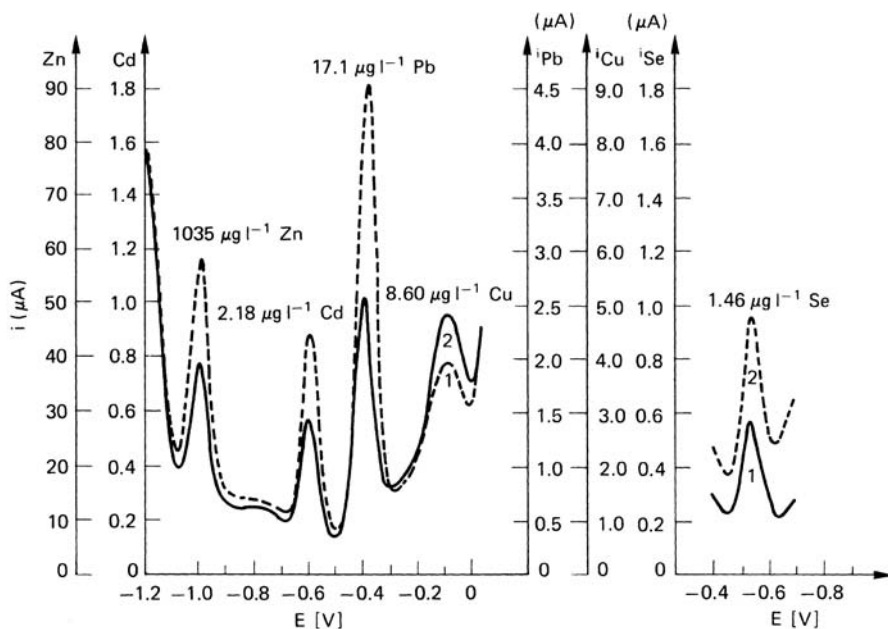

Figure 5.22. Voltammogram of the simultaneous determination of Cu, Pb, Cd, and Zn with DPASV at the HMDE, and subsequent determination of Se^{IV} by DPCSV in the same run in rain water at an adjusted pH of 2. Preconcentration time for DPASV 3 min at -1.2 V, for DPCSV 5 min at -0.2 V. 1 Original analyte. 2 After first standard addition. Total analysis time with two standards. Source: Author's own files

added to 50 ml. Analysis was then performed. For samples where copper was expected to be close to the determination limit of 10 ng/kg, only the film plated during the blank test run was used, thus avoiding an increasing slope due to growth of the mercury film.

Pihlar et al. [795] have described a sensitive differential pulse voltammetric method for the determination of nickel and cobalt in seawater. The pH of the sample is adjusted to 9.2–9.3 by adding an ammonia–ammonium chloride buffer. Optimal ammonia buffer concentration is 0.1 M for nickel concentrations below 10 µg/kg, and 20 µg of a 0.1 M dimethylglyoxime solution in ethanol is added to a 50 ml sample. The analyte is de-aerated for 10 minutes. At the working electrode, a hanging mercury drop electrode, a potential of –0.7 V is adjusted and the nickel–dimethylglyoxime complex is adsorbed at the mercury surface. To speed up mass transfer the solution is stirred with a magnetic bar. Depending on the concentration of nickel (and cobalt), 5–10 min of adsorption time are needed. After a rest period of 30 s the voltammogram is recorded by scanning the potential in the negative direction. Concentrations were evaluated by standard addition.

Other groups of elements that have been determined in seawater by differential pulse stripping voltammetry include cadmium, copper, and zinc [796]; copper, lead, and cadmium [797]; and zinc, cadmium, lead, and copper [773, 798].

Krznaric [799] studied the influence of surfactants (EDTA, NTA) on measurements of copper and cadmium in seawater by differential pulse ASV. Adsorption of surfactants onto the electrode surface were shown to change the kinetics of the overall electrode charge and mass transfer, resulting in altered detection limits. Possible implications for studies on metal speciation in polluted seawater with high surfactant contents are outlined.

Andruzzi et al. [800, 801] discussed the use of a long-lasting sessile-drop mercury electrode in the differential pulse ASV subtrace determination of zinc, cadmium, and lead in seawater. A repeatability of about 3% and a detection limit of 10^{-10} M were achieved for these three metals.

Adsorption Differential Pulse Voltammetry

A number of heavy metals are not capable of forming stable amalgams [859]. Adsorption of suitable species has to be utilised for their electrochemical preconcentration at the electrode interface. Thus, for example, in the determination of copper and nickel, the sample is adjusted to pH 9.2 with ammonia buffer and dimethylglyoxime added to form the copper and nickel chelates. Dimethylglyoxime transforms a certain amount into the chelates Ni(DMG)₂, while another fraction of the overall concentrations of Ni and Co exists as ammonia complexes in the analyte. Then a potential of –0.7 V is adjusted for several minutes at the hanging mercury drop electrode. This potential in the range of the zero-charge potential of the mercury electrode is most favourable for the adsorption of the dimethylglyoxime chelates of both heavy metals. To

speed up mass transfer, the solution is stirred at 900 rpm during the adsorption time. The adsorbed amount of the chelates is proportional to their bulk concentration. As all the complex equilibria in the analyte between the various complexes of nickel and cobalt with ammonia and dimethylglyoxime as ligands are adjusted, the adsorbed amount of their dimethylglyoxime chelates is also proportional to the total bulk concentrations of both heavy metals in the analyte. The proviso is that the adsorbed amounts of the dimethylglyoxime chelates should correspond to the rising part of the adsorption isotherms, and full coverage of the electrode surface is avoided. With this approach, substantial preconcentration is attained at the electrode surface within adsorption times of a few minutes. Then the electrode potential is made more negative in the differential pulse mode until the reduction potentials of nickel and cobalt are reached, and the peaks produced by the reduction of the adsorbed chelate species $\text{Ni}(\text{DMG})_2$ and $\text{Co}(\text{DMG})_2$ are recorded.

The ultimate determination limits obtainable by voltammetric methods are in the range 0.02–0.1 ppb. It is emphasised that these are practical limits. Minimisation of the blanks would enable still lower determination limits to be achieved.

Potentiometric Stripping Analyser

This method in some ways resembles the technique for ASV [321,322]. The analytical device is based on a three-electrode system: (1) a glassy carbon electrode, which serves as a cathode; (2) a saturated calomel electrode (SCE), which is the reference electrode; and (3) a platinum counter-electrode during electrolysis.

Analysis of metal ions in a sample solution is started by electrochemical formation of a mercury film on the glassy carbon electrode. Subsequently, the metal ions are reduced and amalgamated in the mercury film during the electrolysis step (plating). When the plating is terminated, the metals are stripped from the mercury film back into the solution by chemical oxidation. During this step the potential of the carbon electrode (relative to the SCE) is recorded as a function of time. The metals are identified by their stripping potentials, and the quantitative determination is obtained by measuring the stripping time for each metal.

Jagner et al. [802] used this technique to determine zinc, cadmium, lead, and copper in seawater. Their method includes computer control of the potentiometric stripping technique. They compared their results with those obtained by solvent extraction–AAS and showed that the computer-controlled potentiometric stripping technique is more sensitive, and has advantages over ASV. Computer control makes deoxygenation of the sample unnecessary.

Water samples from the Arctic Sea were analysed by the potentiometric stripping technique. Lead (II) and cadmium (II) were determined after pre-electrolysis for 32 min at -1.1 V with respect to Ag/AgCl ; the detection limits were 0.06 and 0.04 nmol/l, respectively. Zinc (II) was determined after the ad-

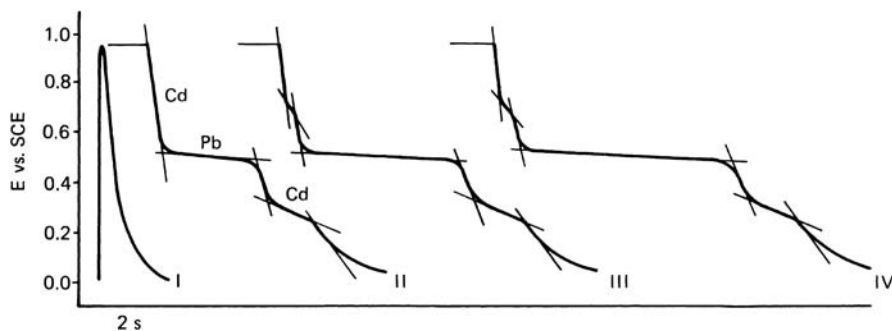

Figure 5.23. Potentiometric stripping curve for a 25 ml seawater sample. I Background. II Curve before standard addition. III and IV Curve after each addition of 5 ng Cd^{II} and 100 µg Pb^{II}. Internal standard: 25 ng Cu^{II}. Plating time 32 min at 95 V relative to SCE. Source: [803]

dition of gallium (III) by pre-electrolysis for 16 min at -1.4 V with respect to Ag/AgCl; the detection limit was 0.25 nmol/l. Problems in the determination of copper (II) at the very low concentrations found in oceanic waters are outlined. The average zinc (II), cadmium (II), and lead (II) concentrations in eight different samples were 2.5, 0.16, and 0.10 nmol/l as determined by potentiometric stripping analysis, and 1.9, 0.16, and 0.09 nmol/l as determined by solvent extraction–AAS. The advantages of this computer-controlled technique for the analysis of seawater are discussed.

Drabek et al. [803] applied potentiometric stripping analysis to the determination of lead, cadmium, and zinc in seawater. The precision was evaluated by several duplicate determinations and was found to be in the range 5–16% relative, depending on the concentration level. The accuracy of the method was evaluated by comparison with other conventional methods, e.g., AAS and ASV, and good agreement between the methods was found.

Figure 5.23 shows typical stripping curves for cadmium, lead, and zinc obtained from a 25 ml seawater sample. The sample was analysed as previously described. The concentrations found were 7.1 µg/l (Pb^{II}), 0.2 µg/l (Cd^{II}), and 4.1 µg/l (Zn^{II}).

5.74.12

Cathodic Stripping Voltammetry

Heavy Metals

Donat and Bruland [804] studied the speciation of copper and nickel in seawater by competitive ligand equilibration–cathodic stripping voltammetry, differential pulse ASV, and graphite furnace AAS.

Donat and Bruland [217] conducted a direct determination of cobalt and nickel in seawater by differential pulse cathodic stripping voltammetry, preceded by absorptive collection of cyclohexane-1,2 dioxime complexes.

Perez-Pina et al. [805] studied the use of triethanolamine and dimethylglyoxime complexing agents in absorptive cathodic stripping voltammetry of cobalt and nickel in seawater. Nickel and cobalt could be determined at levels down to 2 nM and 50 pM, respectively.

Huynk et al. [218] also used differential pulse cathodic stripping voltammetry for the determination of cobalt and nickel in seawater by dimethylglyoxime complexation. They report detection limits of 0.002 $\mu\text{g/l}$ for cobalt and 0.005 $\mu\text{g/l}$ for nickel.

Abollino et al. [690] compared cathodic stripping voltammetry and graphite furnace AAS in determination of cadmium, copper, iron, manganese, nickel, and zinc in seawater. The effects of UV irradiation, acidification, and online sample preconcentration were studied.

Heavy Metals, Uranium, Vanadium, Molybdenum

Cathodic stripping voltammetry has been used [807] to determine lead, cadmium, copper, zinc, uranium, vanadium, molybdenum, nickel, and cobalt in water, with great sensitivity and specificity, allowing study of metal speciation directly in the unaltered sample. The technique used preconcentration of the metal at a higher oxidation state by adsorption of certain surface-active complexes, after which its concentration was determined by reduction. The reaction mechanisms, effect of variation of the adsorption potential, maximal adsorption capacity of the hanging mercury drop electrode, and possible interferences are discussed.

Selenium

Certain trace substances such as Se^{IV} can be determined in similar fashion by differential cathodic stripping voltammetry (DPCSV) [895]. For selenium a rather positive preconcentration potential of -0.2 V is adjusted. Se^{IV} is reduced to Se^{2-} and Hg from the electrode is oxidised to Hg^{2+} at this potential. It forms, with Se^{2-} on the electrode, a layer of insoluble HgSe and in this manner the preconcentration is achieved. Subsequently the potential is altered in the cathodic direction in the differential pulse mode. The resulting Hg^{II} peak produced by Hg^{II} reduction is proportional to the bulk concentration of Se^{IV} in the analyte.

5.74.13

Chronopotentiometry

Nickel and Cobalt

Eskilsson et al. [868] have described equipment for automated determination of traces of cobalt and nickel by potentiometric stripping analysis, which used a freshly prepared mercury film on a glassy carbon support as the working

electrode. The use of concentrated electrolyte (5 M calcium chloride) provided virtually oxygen-free stripping solutions. Analytical procedures for aqueous solutions and biological samples are described.

5.74.14

X-ray Fluorescence Spectrometry

Heavy Metals

Knochel and Prange [812] converted metals in seawater into their diethyldithiocarbamates prior to X-ray fluorescence analysis of the separated solids. Membrane filtration of the precipitates resulted in carbamate-loaded filters, which could be directly measured using radioisotope-excited X-ray fluorescence analysis. Furthermore, elution of Chromosorb columns loaded with the dithiocarbamate complex by the passage of chloroform yielded chloroform solutions in which the trace metals could be determined by X-ray fluorescence analysis using totally reflecting sample supports. Similarly, the precipitate on the membrane filter could be dissolved in chloroform and determined in the resulting solution. The sensitivity of this method and the pH dependence of the reaction were also investigated.

Prange et al. [813] give details of equipment and a procedure for determination of traces of heavy metals by solvent extraction using di-isobutyl ketone and isobutyl methyl ketone, combined with microdroplet analysis by X-ray fluorescence spectrometry using a specially designed filter paper; sodium diethyldithiocarbamate is used as chelating agent. The limits of detection for manganese, iron, cobalt, nickel, copper, zinc, and lead were 15, 16, 8, 8, 13, 13, and 40 $\mu\text{g/l}$, respectively, for a 100 μl sample volume. The method was applied to analyses of seawater from Chirihama, Japan. Results obtained are in fair agreement with the reference values obtained by AAS.

Heavy Metals, Vanadium

Morris [814] separated microgram amounts of vanadium, chromium, manganese, iron, cobalt, nickel, copper, and zinc from 800 ml of seawater by precipitation with ammonium tetramethylenedithiocarbamate, and extraction of the chelates at pH 2.5 with methylisobutyl ketone. Solvent was removed from the extract, the residue was dissolved in 25% nitric acid, and the inorganic residue was dispersed in powdered cellulose. The mixture was pressed into a pellet for X-ray fluorescence measurements. The detection limit was 0.14 μg or better when a 10 min counting period was used.

Heavy Metals, Uranium

Preconcentration by the ring-oven technique [227] and by solvent extraction have both been used in order to improve the sensitivity of X-ray fluorescence

spectrometry. Armitage and Zeitlin [227] converted uranium, copper, nickel, cobalt, iron, and manganese to the 8-hydroxyquinolates and extracted these with chloroform. The extract was applied to a filter paper disk in a ring oven at 160 °C, and the metals were separated prior to final determination by the X-ray technique.

Heavy Metals, Vanadium, Molybdenum, Mercury, Uranium, Potassium, Calcium, Titanium, Gallium, Arsenic, Selenium, Rubidium, Strontium, Yttrium, Zirconium, Silver, Antimony, and Barium

Prange et al. [809, 810] carried out multielement determinations of the stated dissolved heavy metals in Baltic seawater by total reflection X-ray fluorescence (TXRF) spectrometry. The metals were separated by chelation adsorption of the metal complexes on lipophilised silica-gel carrier and subsequent elution of the chelates by a chloroform/methanol mixture. Trace element loss or contamination could be controlled because of the relatively simple sample preparation. Aliquots of the eluate were then dispersed in highly polished quartz sample carriers and evaporated to thin films for spectrometric measurements. Recoveries (see Table 5.10), detection limits, and reproducibilities of the method for several metals were satisfactory.

This analytical method, based on TXRF, enables a large number of trace elements to be determined simultaneously. The range is suitable for different areas of the sea. The motivation to use TXRF resulted mainly from the characteristic features of the method: its high detection power, its universal calibration curve, which eliminates the need for matrix-dependent standard samples or standard-addition procedures, the simple preparation of the sample films, and of course the possibility of multielement determination.

Haarich et al. [811] applied total reflection X-ray fluorescence spectrometry to the determination of a wide range of miscellaneous metals in seawater.

5.74.15

Neutron Activation Analysis

The application of neutron activation analysis to water samples has several advantages. Like inductively coupled plasma atomic absorption spectrometry it is a multielement analysis technique, and as such it is useful for performing element scans when looking for unknown elements. It enables several elements to be determined in the same run. It is not limited to metallic elements. Its disadvantage is high cost and the probability that most laboratories cannot house the reactor equipment, so that in fact samples must be sent away for analysis to an establishment with such facilities. This delays results and demands careful consideration of sample preservation during the waiting period. The technique is intrinsically sensitive, and can be made more so by pre-concentrating the metals onto a resin such as Chelex 100, which can be directly

Table 5.10. Recoveries determined by standard addition to seawater with APDC or NaDBDTC as the chelating agent

Element	Element found (ng/kg) with APDC			Element found (ng/kg) with NaDBDTC			
	Additional standard (ng/kg)	Before addition	After addition	Yield (%)	Before addition	After addition	Yield (%)
V	2500	148 ± 61	188 ± 79	-	1540 ± 100	3920 ± 70	95.3 ± 5.2
Mn	1000	-	-	-	32 ± 6	917 ± 9	88.5 ± 1.2
Fe	1000	353 ± 51	1320 ± 43	96.3 ± 4.8	344 ± 17	1370 ± 20	102.8 ± 2.9
Co	1000	internal	standard	100	internal	standard	100
Ni	1000	165 ± 15	735 ± 21	57.0 ± 6.9	241 ± 12	1230 ± 20	99.2 ± 2.4
Cu	1000	93 ± 23	790 ± 17	69.7 ± 6.1	107 ± 2	1090 ± 20	98.2 ± 2.3
Zn	1000	64 ± 12	146 ± 18	8.2 ± 6.4	179 ± 3	1190 ± 23	100.8 ± 2.3
Se	2500	-	1970 ± 100	78.8 ± 5.1	-	2530 ± 30	101.0 ± 3.1
Mo	5000	5590 ± 240	9210 ± 170	72.3 ± 9.8	10 200 ± 490	15 200 ± 670	100.2 ± 5.5
Cd	1000	-	313 ± 23	31.3 ± 2.3	-	984 ± 25	98.4 ± 2.5
Hg	1000	196 ± 27	925 ± 44	72.9 ± 6.1	75 ± 10	1050 ± 30	97.6 ± 2.9
Pb	1000	35 ± 7	472 ± 31	43.7 ± 5.2	49 ± 4	1100 ± 40	105.2 ± 3.8
U	2500	557 ± 51	772 ± 65	8.6 ± 3.1	3100 ± 190	5650 ± 110	102.1 ± 8.6

N = 3

From: [809]

APDC: ammonium pyrrolidene dithiocarbamate

NaDBDTC: sodium dibenzylidithio carbamate

Table 5.11. Application of neutron activation analysis to the determination of metals in seawater

Elements	Sample pre-concentration	Reference
Co, Cr, Ca, Fe, Pb, Se, Sr	Sea salts Freeze dried	[817]
As, Cu, Sb	Thionalide precipitation	[818]
Misc. elements	Frozen sample	[819]
Al, V, Cu, Mo, Zn, U	Organic co-precipitants (8-hydroxyquinoline)	[21]
Ag, Au, Cd, Ce, Co, Cr, Eu, Fe, Hg, La, Mo, Sc, Se, U, Zn, As, Sb	Adsorption and charcoal	[628]
Ba, Ca, Cd, Ce, Co, Cr, Cu, Fe, La, Mg, Mn, Sc, U, V, Zn	Adsorption of Chelex-100 glass powder	[627]
Hg, Au, Cu	Co-precipitation with lead diethyldithiocarbamate	[820]
12 elements	Chelating resin	[821]
Transition metals	Chelating resin	[822]
As, Mo, U, V	Colloid flotation	[823]
Th	Ion exchange chromatography	[889]
Co, Cu, Hg	Co-precipitation with lead pyrrolidine dithiocarbamate	[824]

Source: Author's own files

analysed by the neutron activation technique. With these facilities, analysis for many metals at the ultra-low background levels at which they occur in seawater becomes a possibility.

Some applications of neutron activation analysis to seawater analysis are summarised in Table 5.11.

The application of neutron activation techniques to the measurement of trace metals in the marine environment has been reviewed by Robertson and Carpenter [815,816].

Heavy Metals

Stiller et al. [824] have described the determination of cobalt, copper, and mercury in Dead Sea water by neutron activation analysis followed by X-ray spectrometry and magnetic deflection of β -ray interference.

The metals were coprecipitated with lead-ammonium pyrrolidine dithiocarbamate and detected by X-ray spectrometry following neutron activation. Magnetic fields deflect the β rays while the X rays reach the silicon (lithium) detector undeviated. The detectors have low sensitivity to γ rays. The concentration of cobalt found by this method was 1.3 $\mu\text{g/l}$, about one-fifth of that measured previously, while that of copper, 2.0 $\mu\text{g/l}$, agreed with results obtained by some previous workers. The concentration of mercury was 1.2 $\mu\text{g/l}$.

Arsenic, Molybdenum, Uranium, and Vanadium

Murthy and Ryan [823] used colloid flotation as a means of preconcentration prior to neutron activation analysis for arsenic, molybdenum, uranium, and vanadium. Hydrous iron (III) oxide is floated in the presence of sodium decyl sulfate with small nitrogen bubbles from 1 litre of seawater at pH 5.7. Recoveries of arsenic, molybdenum, and vanadium were better than 95%, whilst that of uranium was about 75%.

Silver, Chromium, Cadmium, Copper, Manganese, Thorium, Uranium, and Zirconium

Holzbecker and Ryan [825] determined these elements in seawater by neutron activation analysis after coprecipitation with lead phosphate. Lead phosphate gives no intense activities on irradiation, so it is a suitable matrix for trace metal determinations by neutron activation analysis. Precipitation of lead phosphate also brings down quantitatively the insoluble phosphates of silver (I), cadmium (II), chromium (III), copper (II), manganese (II), thorium (IV), uranium (VI), and zirconium (IV). Detection limits for each of these are given, and thorium and uranium determinations are described in detail. Gamma activity from ^{204}Pb makes a useful internal standard to correct for geometry differences between samples, which for the lowest detection limits are counted close to the detector.

Cadmium, Cobalt, Chromium, Copper, Iron, Manganese, Molybdenum, Nickel, Scandium, Tin, Thorium, Uranium, and Zinc

Greenberg and Kingston [821, 822] used a solid Chelex 100 resin to preconcentrate these elements from 100–500 ml of estuarine and seawater prior to their determination. A procedure is described for the preconcentration of 100 ml of estuarine and seawater into a solid sample using Chelex 100 resin. This solid sample weighs less than 0.5 g, and contains the transition metals and many other elements of interest, but is essentially free of alkali metals, alkaline earth metals, and halogens.

The application of the Chelex 100 resin separation and preconcentration, with the direct use of the resin itself as the final sample for analysis, is an extremely useful technique. The elements demonstrated to be analytically determinable from high salinity waters are cobalt, chromium, copper, iron, manganese, molybdenum, nickel, scandium, thorium, uranium, vanadium, and zinc. The determination of chromium and vanadium by this technique offers significant advantages over methods requiring aqueous final forms, in view of their poor elution reproducibility. The removal of sodium, chloride, and bromide allows the determination of elements with short and intermediate half-lives without radiochemistry, and greatly reduces the radiation dose received by personnel. This procedure was successfully applied in a study of

more than 100 samples collected throughout the entire length of the Chesapeake Bay. The salinity of these samples varied from that of fresh water to that of Atlantic Ocean water.

Thorium

Huh and Bacon [589] used neutron activation analysis to determine ^{232}Th in seawater. Seawater samples were subjected to pre- and post-irradiation procedures. Separation and purification of the isotopes, using ion exchange chromatography and solvent extraction, were performed during pre-irradiation. After irradiation, ^{233}Pa was extracted and counted. Yields were monitored with ^{230}Th and ^{231}Pa tracers. Measured ^{232}Th concentrations were 27×10^{-7} dpm/kg for deep-water samples from below 400 m.

Multiple Elements

In a procedure [627] employing preconcentration of the metals on a column containing a mixture of Chelex 100 and Pyrex glass powder, the problems associated with swelling of the Chelex 100 were overcome and constant flow rates of sample down the column achieved. The water samples were passed through the resin column and eluted with 100 ml 0.01 M nitric acid, and the eluate was discarded. Trace elements were collected from the column by eluting with 50 ml 4 M nitric acid. The eluate was heated to reduce its volume, transferred to a volumetric flask, and diluted to 10 ml.

A 3.5 ml portion in a 4 ml polyethylene vial was irradiated for 5 min. Another portion, 3.0 ml in a 3.5 ml silica vial, was irradiated for 3 d. After the short irradiation, 3 ml of the irradiated solution were transferred into an activity-free vial and submitted to γ -ray spectrometry with a Ge(Li) detector coupled to a 4000-channel analyser. After the long irradiation, the sample was allowed to cool for 3 d, then the surface of the silica ampoule was cleaned with dilute nitric acid and the sealed ampoule was placed in the counter (the background activity of the ampoule was negligible). Gamma-ray energy and the areas under peaks were calculated by computer. To determine the half-lives of the nuclides produced, the counting was repeated at appropriate intervals.

The major interfering elements such as sodium, potassium, bromine, and chlorine (Figs. 5.24 and 5.25) were completely removed from the column with 100 ml 0.01 M nitric acid, whereas many trace elements were quantitatively retained. These elements were eluted with the succeeding 50 ml of 4 M nitric acid.

The recovery ratios indicate that the added traces of cadmium, cerium, copper, lanthanum, manganese, scandium, and zinc are quantitatively recovered. The recoveries of barium, cobalt, bromine, iron, uranium, and vanadium were also satisfactory.

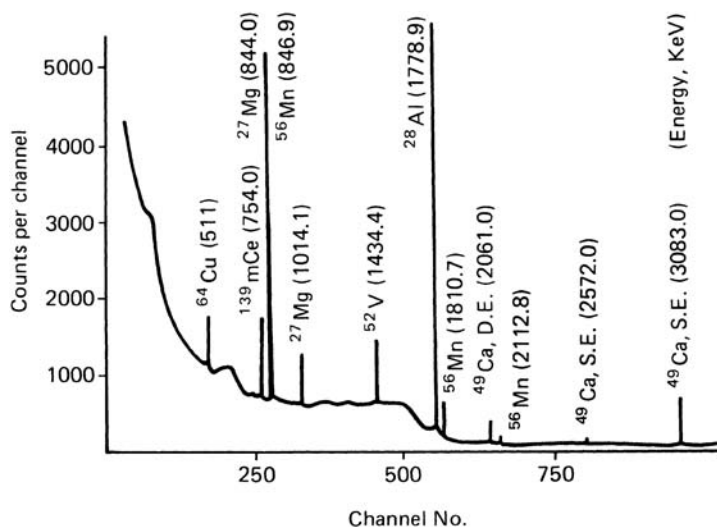

Figure 5.24. Gamma-ray spectrum of preconcentrated river water after short irradiation. Irradiation time 5 min; thermal-neutron flux $1 \times 10^{13} \text{ n cm}^{-3} \text{ s}^{-1}$; decay time 3 d; counting time 1000 s. Source: [627]

Recoveries of calcium and magnesium were very poor for seawater. The reasons for this may be connected with matrix effects.

In order to evaluate the precision of this method, replicate analyses were carried out by Lee et al. [627] using the proposed procedure, for trace elements in a seawater sample taken from the Kwangyang Bay (Korea). The results showed satisfactory precision ranging from $0.2 \mu\text{g/l}$ for cadmium to $250 \mu\text{g/l}$ for iron.

Lieser et al. [628] studied the application of neutron activation analysis to the determination of trace elements in seawater, with particular reference to the limits of detection and reproducibility obtained for different elements when comparing various preliminary concentration techniques such as adsorption on charcoal, cellulose, and quartz, and complexing agents such as dithizone and sodium diethyldithiocarbamate.

In these procedures 1 litre of seawater was shaken with 60 mg charcoal for 15 min. Complexing agents were added in amounts of 1 mg, dissolved in 1 ml of acetone. The pH was 5.5, or it was adjusted to 8.5 by addition of 0.1 M ammonia. The charcoal was filtered off and irradiated. Results of three sets of experiments with charcoal alone, charcoal in the presence of dithizone, and charcoal in the presence of sodium diethyldithiocarbamate are compared. The following elements are adsorbed to an extent from 75 to 100%: silver, gold, cerium, cadmium, cobalt, chromium, europium, iron, mercury, lanthanum, scandium, uranium, and zinc. The amount of sodium is reduced to about 10^{-6} , bromine to about 10^{-5} , and calcium to about 10^{-2} .

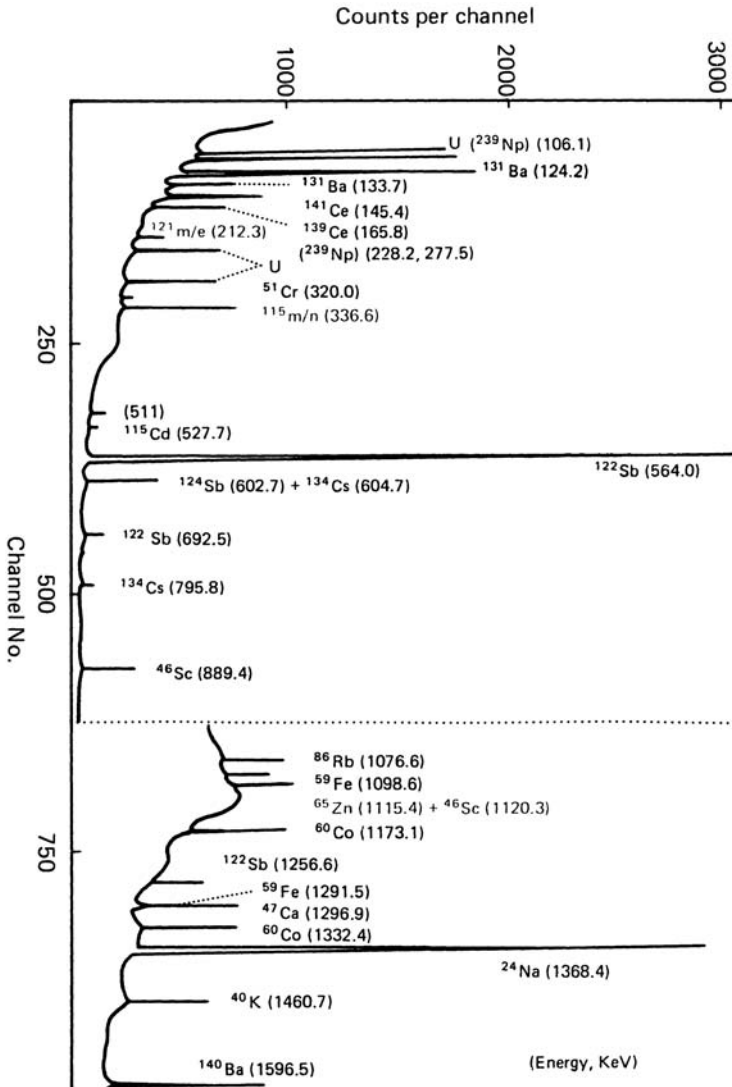

Figure 5.25. Gamma-ray spectrum of preconcentrated seawater after long irradiation. Irradiation time 3 days; thermal-neutron flux $1 \times 10^{13} \text{ n cm}^{-2} \text{ s}^{-1}$; decay time 3 d; counting time 1000 s. Source: [627]

5.74.16 Isotope Dilution Mass Spectrometry

This technique has been used to determine a number of elements in seawater, including lithium [826], barium [74], lead [827], rubidium [840], uranium [828], and copper [298, 299]. It has not been extensively applied.

The earlier stable isotope dilution mass spectrographic work was accomplished with a thermal ion mass spectrometer which had been specifically designed for isotope abundance measurements. However, Leipziger [829] demonstrated that the spark source mass spectrometer could also be used satisfactorily for this purpose. Although it did not possess the excellent precision of the thermal unit, Paulsen and coworkers [830] pointed out that it did have a number of important advantages.

In the analysis of seawater, isotope dilution mass spectrometry offers a more accurate and precise determination than is potentially available with other conventional techniques such as flameless AAS or ASV. Instead of using external standards measured in separate experiments, an internal standard, which is an isotopically enriched form of the same element, is added to the sample. Hence, only a ratio of the spike to the common element need be measured. The quantitative recovery necessary for the flameless atomic absorption and ASV techniques is not critical to the isotope dilution approach. This factor can become quite variable in the extraction of trace metals from the salt-laden matrix of seawater. Yield may be isotopically determined by the same experiment or by the addition of a second isotopic spike after the extraction has been completed.

An outline of the elements in seawater that can be analysed by isotope dilution techniques has been presented by Chow [831]. Most of the subsequent work concerns the analysis of lead in seawater [184, 831–835]. The extension of the technique to the analysis of copper, cadmium, thallium, and lead has been made by Murozumi [835] using a thermal source mass spectrometer, whereas Russell and Sturgeon [937] used a spark source mass spectrometer in the determination of iron, cadmium, zinc, copper, nickel, lead, and uranium in seawater. It may be noted that thermal source mass spectrometry has two prime advantages over spark source mass spectrometry that may be of particular value in seawater analysis. One is the much higher precision (about 0.1%) available from the instrument, a factor important in assessing the stability of the trace metals in seawater with time or the extraction technique itself. Secondly, the ratios to be determined may be measured at various filament currents (temperature) for an internal corroboration. This is of particular importance in detecting isobaric interferences that might lead to spurious ratios and hence misleading results.

One of the advantages of the isotope dilution technique is that the quantitative recovery of the analytes is not required. Since it is only their isotope ratios that are being measured, it is necessary only to recover sufficient analyte to make an adequate measurement. Therefore, when this technique is used in conjunction with graphite furnace atomic absorption spectrometry, it is possible to determine the efficiency of the preconcentration step. This is particularly important in the analysis of seawater, where the recovery is very difficult to determine by other techniques, since the concentration of the unrecovered analyte is so low. In using this technique, one must assume that isotopic equilibrium has been achieved with the analyte, regardless of the species in which it may exist.

The thermal ion mass spectrometer was specifically developed for the measurement of isotope abundances and is capable of excellent precision. Although the spark source mass spectrometer used in this work lacks some of this precision, it has proved very useful in stable isotope dilution work. It has a number of advantages, including greater versatility, relatively uniform sensitivity, and better applicability to a wide range of elements.

Heavy Metals

Stuckas and Wong [836] have investigated the feasibility of using a thermal source mass spectrometer in the isotope dilution analysis of copper, cadmium, lead, zinc, nickel, and iron in seawater. The approach basically follows that which had been successfully employed in the analysis of lead in seawater [834]. Great importance was attached to the definition of the blank and the initial clean-up schedule. Once the operating parameters had been established by the analysis of pure isotopic spikes, the various components that constitute a blank were identified and minimised where possible using ultraclean-room techniques. The subsequent extractions of reagent water and seawater by dithizone and by ammonium pyrrolidine–diethyldithiocarbamate ion exchange resins were evaluated for suitability for the isotope dilution mass spectrometric approach, yield, and contamination levels. The results obtained on seawater were corroborated by two independent techniques, ASV and flameless AAS. Satisfactory agreement was obtained in most cases.

Wu and Boyle [837] have developed a method using magnesium hydroxide coprecipitation and isotopic dilution mass spectrometry to determine lead, copper, and cadmium in 1 ml seawater samples, with detection limits of 1, 40, and 5 pM, respectively.

Heavy Metals, Uranium

Mykytiuk et al. [184] have described a stable isotope dilution spark source mass spectrometric method for the determination of cadmium, zinc, copper, nickel, lead, uranium, and iron in seawater, and have compared results with those obtained by graphite furnace atomic absorption spectrometry and inductively coupled plasma emission spectrometry. These workers found that to achieve the required sensitivity it was necessary to preconcentrate elements in the seawater using Chelex 100 [121] followed by evaporation of the desorbed metal concentrate onto a graphite or silver electrode for isotope dilution mass spectrometry.

Caesium and Chromium

Riel [838] extracted caesium and chromium from seawater using an underwater probe and X-ray spectrometry unit.

Lanthanides

See Sect. 5.49.15.

5.74.17

High-Performance Liquid Chromatography

Aluminium, Iron, and Manganese

Nagaosa et al. [839] simultaneously separated and determined these elements in seawater by high-performance liquid chromatography (HPLC) using spectrophotometric and electrochemical detectors.

Copper, Nickel, and Vanadium

In a method for the determination of copper, nickel, and vanadium in seawater, Shijo et al. [840] formed complexes with 2-(5-bromo-2 pyridylazo)-5-(*N*-propyl-*N*-sulfopropylamino) phenol and extracted these from the seawater with a xylene solution of capriquat. Following back-extraction into aqueous sodium perchlorate, the three metals were separated on a C₁₈ column by HPLC using a spectrophotometric detector.

Transition Metals

Riccardo et al. [841] showed that chitosan is promising as a chromatographic column for collecting traces of transition elements from salt solution and seawater, and for recovery of trace metal ions for analytical purposes. Traces of transition elements can be separated from sodium and magnesium, which are not retained by the chitosan.

5.74.18

Metal Speciation

Examining the vertical distribution of trace elements in the ocean yields valuable clues about their chemical behaviour and cycling mechanisms in the water column [263, 519, 842]. The next step in refining our understanding of the elements' marine chemistry is to examine their chemical speciation. Knowledge of the chemical forms of trace elements in seawater, and their relative reactivity and distribution coefficients for uptake on particles, greatly assists the interpretations of observed vertical distributions or removal rates. This information is particularly important for estuarine or coastal environments where, because of rapidly changing conditions of the water column, steady-state vertical distributions of elements cannot be used to understand their reactivities. Furthermore, these waters receive large natural or anthropogenic inputs of

potentially harmful substances. With their often restricted circulation, it is imperative to know what controls the movement of these chemicals through the system, in order to predict whether they will be concentrated locally, and in what form, or if they will be diluted into the ocean [843,844].

Chemical separation studies can help to understand the fate of various trace elements by addressing the following questions:

1. Do the elements associate rapidly with a particulate phase and settle to the bottom to accumulate, or are they transported with bottom sediments?
2. To what extent, and at what rate, do they become involved in the biological cycle, either
 - (a) through complexation with dissolved organic matter, which may keep them in solution, or
 - (b) by bioaccumulation in organisms and subsequent transport and recycling with biotic components?
3. Do the trace elements remain in true solution, to be diluted throughout the ocean by mixing?

To begin to answer these questions, the chemical forms and removal rates of more than 20 trace metals and metalloids, added in radioactive form to large synthetic ecosystems (“microcosms”), have been studied.

Chemical speciation studies of trace metals in seawater are of two types. One group consists of theoretical equilibrium models based on known thermodynamic data, derived generally from studies of less complex solutions [843,845–847]. The second approach (Amdurer [847]) is to determine directly the chemical forms of trace elements by electrochemical techniques or wet-chemical separation schemes [276,848,851]. The problem with this approach is that the “species” identified are often operationally defined by the method used, making it difficult to compare the results of various methods or to compare these results to equilibrium predictions. Nevertheless, these “operational” systems may be more useful for predictive purposes. The use of radiotracers made it possible to simultaneously examine the relative behaviour of a large number of trace elements with widely-differing chemical properties. By studying the changes in chemical form with time following addition of the tracers, it is possible to infer the reactivity, chemical transformations in the water column, and major removal mechanisms of these elements. These studies provide unique “fingerprints” of each trace element according to the phases in which it occurs. This approach permits the grouping of elements with similar chemical forms and removal patterns. If we understand the pathways of an element through a particular environment, we can then predict the behaviour of like elements in similar systems.

The experiments performed by Amdurer [847] were not intended to study chemical speciation or cycling of natural elements in the ecosystem. To do this, the tracers must be fully equilibrated with all of the reactive (i.e., non-matrix) phases of the stable elements. This equilibration may require a time

period equal to or greater than the duration of the experiment. There is ample evidence that ^{65}Zn , for example, may take years to fully equilibrate with the natural organically-complexed fraction of stable zinc (II) [855], and the same may be true of ^{55}Fe [850]. Rather, the radiotracers, added in ionic form, are analogs for the low-level input of similarly dissolved pollutant metals, such as may occur in some industrial or municipal effluents.

Van den Berg [852] has studied trace metal speciation in seawater. This concentrates on the complex-forming transition metals, copper, lead, zinc, and cadmium. Both inorganic and organic speciation interactions are discussed. Studies of both types of species in seawater are reviewed. The values determined by these workers have been used to calculate the products of stability constants and ligand concentrations in seawater as a measure of the speciation of the metal ions. The results of a number of recent studies of interactions between metal ions and organic matter in seawater were compared. Organic-metal interactions can be considerable, at least in surface waters. It is not yet known whether deep sea samples are similarly affected but, since the compounds are probably derived from primary production, the highest ligand concentrations are to be expected in the surface waters.

Stolzberg [143] has discussed potential inaccuracies in trace metal speciation measurement in the determination of copper and cadmium by differential pulse polarography and ASV.

This author reviews the limitations of ASV and differential pulse polarography in determining trace metal speciations, and thereby bioavailability and transport properties of trace metals in natural waters. In particular, it is stressed that nonuniform distribution of metal-ligand species within the polarographic cell represents another limitation inherent in electrochemical measurement of speciation. Examples relate to the differential pulse polarographic behaviour of cadmium complexes of NTA and EDTA in seawater.

Midorikawa et al. [853] have conducted studies on the complexing ability of natural ligands in seawater for various metal ions using ion-selective electrodes. Organic ligands (nominal molecular weight around 1000) are concentrated from seawater and desalted by lyophilisation and dialysis. The concentrated solution of natural ligands is electrodialedysed with ethylene diamine tetra-acetic acid to remove metal ions. The demetallised ligands obtained in this way are titrated with a metal ion to determine the complexing ability of the natural ligands. The advantages of this method are as follows: the formation of a complex between organic ligands and a specific metal ion can be studied without consideration of simultaneous side reactions; samples from distinct sources (saline and fresh water, biological, sedimentary, etc.), can be compared on the same basis; repeated measurements can be made with the same sample after removal of the exogenously added metal ions. The ability of natural ligands in seawater to form complexes with copper (II) and cadmium (II) is discussed.

Mackey [854] studied the suitability of Amberlite XAD-1 resin for extracting organic complexes of copper, zinc, and iron from seawater. The results suggest

Table 5.12. Pre-concentration of cations

Cation	Pre-concentration method	Analytical finish	Detection limit	Reference
Aluminium	Flow injection with in-line pre-concentration on column of resin immobilised-8-hydroxyquinoline	Spectrofluorimetry	-	[859]
Aluminium	Extraction with trifluoro-acetyl acetone in toluene	Analysis of toluene extract by GC	6 pg Al in 2 μ l extract	[18]
Aluminium	Extraction of pyrocatechol violet complex with chloroform	Spectrophotometry at 590 nm	< 0.1 μ g/l	[26]
Antimony	Sb(III) and Sb(VI) adsorbed as ammonium pyrrolidine dithiocarbamate complexes onto C ₁₈ bonded silica	Graphite furnace AAS	0.05 μ g/l	[860]
Antimony	¹²⁵ Sb adsorbed on to MnO ₂	γ -Ray spectrometry	0.4 mBq/l	[587]
Antimony	Sb(III) and Sb(V) converted to hydrides, cold trapping in toluene	AAS	0.04 μ g/l	[59, 60, 63, 861]
Antimony	Sb(III) and Sb(V) adsorbed on ammonium pyrrolidine dithiocarbamates on C ₁₈ bonded silica	Graphite furnace AAS	0.05 ng/l	[860]
Arsenic	As(III) and As(V) complexed with ammonium pyrrolidine diethyl dithio carbamate and extracted with chloroform	Chloroform extract examined by NAA	-	[862]
Arsenic	Arsenic determined by cathodic stripping	CSV	0.3 nmol	[621]
Barium	Barium pre-concentrated on cation exchange resin, then extraction with nitric acid	Graphite furnace AAS	-	[78]
Beryllium	Beryllium pre-concentrated as acetylacetone complex onto activated charcoal	Charcoal introduced directly into graphite furnace AAS	0.6 ng/l	[79]
Bismuth	Liquid-liquid extraction into xylene as the ammonium pyrrolidine dithiocarbamate complex	Electrothermal AAS	0.0006 μ g/l	[95]
Cadmium	Extraction of ammonium pyrrolidine dithiocarbamate complex with chloroform	AAS	0.3 ppt or 0.0005 μ g/l	[134, 863]
Cadmium	Co-precipitation with zirconium hydroxide, dissolution of precipitate in hydrochloric acid	Square wave polarography at -0.6 V	-	[144]
Cadmium	Cadmium collected on Chelex-100 resin and elution with nitric acid	Graphite furnace AAS	-	[118]

Table 5.12. (continued)

Cation	Pre-concentration method	Analytical finish	Detection limit	Reference
Caesium	Chelation as copper hexacyano ferrate(II) on silica	AAS	-	[864]
Caesium	^{137}Cs adsorption on strong cation exchange resin ammonium hexacyano cobalt ferrate, dissolution in hydrochloric acid	β counted for ^{137}Cs	10 pCi/l	[865]
Caesium	hydrofluoric acid Cs complexed with 4-tetrabutyl-2(α -methyl benzyl) phenol and solvent extracted	AAS	-	[149]
Calcium	Adsorption on Chelex-100 resin, desorbed with hydrochloric acid	Flame photometry at 622 nm	-	[167]
Cerium	Ce(IV) co-precipitation with ferric hydroxide, dissolution in hydrochloric acid, then passed through a column of bis(2 ethyl hexyl) phosphate on poly(vinylchloride), eluted with 0.3 M perchloric acid	Spectrofluorimetry at 350 nm (excitation 255 nm)	-	[626]
Chromium	Co-precipitation of Cr(IV) and Cr(III) with lead sulfate	NAA	0.1 $\mu\text{g/l}$ (800 μl sample)	[95]
Chromium	Immobilised diphenylcarbazone	Zeeman AAS	-	[178]
Chromium	Cr(III) converted to Tris (1,1,1, trifluoro 2,4 pentanediono) chromium(III), extracted with hexane	Isotope dilution GC-MS	-	[181, 183, 867]
Chromium	Cr(III) adsorbe on silica, oxidised to chromium(IV) by UV digestion	CSV	0.0016 $\mu\text{g/l}$	[186]
Cobalt	Complexation with 2-ethyl-amino-5-nitrosophenol, extraction with dichloroethane	Spectrophotometry at 402 nm	< 0.07 $\mu\text{g/l}$	[224]
Cobalt	Pre-concentration on manganese dioxide, solution in hydrochloric acid	Pulse polarography	-	[231]
Cobalt	Complexation with 4-(2-thiazolylazo) resorcinol, adsorption on XAD-4, resin elution with methanol:chloroform	Graphite furnace AAS	-	[234]
Cobalt	Co-precipitation with sodium diethyl dithio carbamate	X-ray fluorescence spectrometry	0.3 $\mu\text{g/l}$	[511]

Table 5.12. (continued)

Cation	Pre-concentration method	Analytical finish	Detection limit	Reference
Cobalt	Co(III) adsorbed on C ₁₈ bonded silica	Laser excited atomic fluorescence spectrometry	-	[241]
Cobalt	Co(III) adsorbed on 8-quinolol adsorbed on silica	Chemical luminescence	-	[244]
Copper	Adsorption on Amberlite XAD-4	Miscellaneous	-	[854]
Copper	Extraction of ammonium pyrrolidine dithiocarbamate complex with MIBK	Miscellaneous	< 0.5 µg/l	[374]
Copper	Adsorption on chitosan, extraction with 1,10 phenanthroline	AAS	< 0.1 µg/l	[841]
Copper	Extraction with 8-quinolol in ethyl propionate	Electron spin resonance spectroscopy	< 2 µg/l	[300]
Copper	Adsorption on hydroxyquinoline, dithizone or diethyldithiocarbamate modified charcoal	Miscellaneous	-	[301]
Copper	Adsorption on silica modified with 8-quinolol	Flow injection AAS	-	[868]
Copper	Adsorption on C ₁₈ bonded silica	-	-	[332]
Copper	Adsorption on basic Amberlite GC-400 anion exchange resin, elution with nitric acid	AAS	0.013 µg/l	[869]
Copper	Adsorption on C ₁₈ resin	Laser excited atomic fluorescence spectrometry with a graphite electrothermal atomiser	0.001 µg/l	[241]
Indium	Co-precipitation with gallium phosphate	Electrothermal AAS	0.3 µg/l (500 ml sample)	[870]
Iron	Conversion to bathophenanthroline complex adsorption on anion exchange resin (Amberlite A27)	Densitometric scanning of resin at 550 nm	-	[350]
Iron	Iron co-precipitated with tetraphenyl boron/1,10-phenanthroline, precipitate dissolved in ammoniacal ethanol	Miscellaneous	-	[568]

Table 5.12. (continued)

Cation	Pre-concentration method	Analytical finish	Detection limit	Reference
Iron	Adsorbed on ferrozine impregnated C ₁₈ resin	Spectrophotometry	0.1 mM/l	[351]
Iron	Pre-concentrated on 8-quinolol chelating resin	Chemiluminescence	50 pmol/l 0.0025 µg/l (18 ml sample)	[349]
Lead	Electrochemical pre-concentration of controlled potentials	Electrochemical	-	[365, 395]
Lead	Lead extracted from water with chloroformic dithizone	pre-concentration AAS Graphite furnace AAS	-	[364]
Lead	Lead co-precipitated with Ni ₃ K ₂ [Fe(CN) ₆]	X-ray fluorescence spectrometry	2-4 µg absolute	[541]
Lead	Lead pre-concentrated on Chelex-100 resin	Inductively coupled plasma atomic emission spectrometry	0.6 ng/l 0.0006 µg/l compared to 60 ng/l (0.06 µg/l) by direct nebulisation	[871, 872]
Lead	Complexation with ammonium pyrrolidine dithiocarbamate, collection on C ₁₈ microcolumn	Graphite furnace AAS	3.5 ng/l	[873]
Lead	Complexation with DDPA adsorption on C ₁₈ microcolumn, elution with methanol	Laser enhanced ionisation	3.3 µg/l (15 ml sample)	[360]
Manganese	Manganese complexed with ammonium and diethyl ammonium diethyldithiocarbamate and extracted with Freon extract	Electrothermal AAS of Freon	-	[65, 448]
Manganese	Extraction with chloroformic 8-quinolol, back extraction into aqueous nitric acid	Graphite furnace AAS	< 30 ng/l 0.03 µg/l	[432, 444]
Manganese	Extraction of manganese with a heptane solution of bis (2-ethyl hexyl) phosphate	Spectrophotometric	-	[874]
Manganese	Adsorption on Chelex-100, extraction of manganese with 2 N nitric acid	Graphite furnace AAS	-	[129, 450, 451]
Manganese	Complexation with theonyl-trifluoroacetone and dibenzol-8-crown-6	AAS	0.1 µg/l	[875]

Table 5.12. (continued)

Cation	Pre-concentration method	Analytical finish	Detection limit	Reference
Mercury	Hg reduced to elemental mercury, extract which is swept onto gold foil	AAS	0.2 pM (absolute)	[460, 467, 469, 472, 478, 481, 875-877] [878]
Mercury	Mercury converted to diethyldithiocarbamate, concentrated XAD-2 resin, eluted with methanolic hydrochloric acid	Flameless AAS	0.1 ng/l	
Mercury	Mercury complexed with ammonium tetra methylene-dithiocarbamate, extracted with chloroform	Chloroform extract analysed by graphite tube AAS	< 5 ng/l Hg absolute	[479, 879]
Mercury	Anodic stripping voltammetry with glassy carbon electrode spin coated with 4,7,13,16,21,42 hexaoxa, 1,10 diazabicyclo [8, 8, 8] hexacosane	-	-	[483]
Mercury	Comparison on different mercury chelating agents adsorbed onto silica C ₁₈ resin	Cold vapour AAS	0.016 µg/l	[880]
Molybdenum	Co-precipitation methods	-	-	[881-885]
Molybdenum	Solvent extraction methods	-	-	[21, 514, 886, 888]
Molybdenum	Co-crystallisation methods	-	-	[21, 514, 886-888]
Molybdenum	Sorption on solids or Chitosan modified cellulose	AAS	-	[137, 502, 503, 888, 889]
Molybdenum	Cation exchange adsorption	-	-	[891]
Molybdenum	Cation exchange adsorption on Chelex-100	-	-	[892, 893]
Molybdenum	Anion exchange resin adsorption (Biorad Ag1-X8), elution with ammonia	Graphite furnace AAS	< 10 µg/l	[508]

Table 5.12. (continued)

Cation	Pre-concentration method	Analytical finish	Detection limit	Reference
Molybdenum	Anion-exchange on Dowex 1-X8 resin or Amberlite GC-40 resin	Spectrophotometry	-	[497-500, 516, 894]
Molybdenum	Adsorption of molybdenum pyrrolidine dithiocarbamate on charcoal	-	-	[895]
Molybdenum	Co-precipitation with $Zr(OH)_4$	Inductively coupled plasma AES	-	[896]
Nickel	Nickel is co-precipitated with sodium diethyldithiocarbamate and the precipitate dissolved in nitric acid	AAS	0.5 ng/l	[897]
Nickel	Nickel adsorbed onto poly (triaminophenyl)glyoxal, desorbed with ammonium pyrrolidine dithiocarbamate in MIKB	AAS	-	[897]
Nickel	Solvent extraction techniques	Miscellaneous	-	[122]
Nickel	Co-precipitation techniques	Miscellaneous	-	[518-520]
Nickel	Nickel dimethyl glyoxime complex extracted from water with chloroform	AAS	5 $\mu\text{g/l}$	[899]
Nickel	Nickel converted to $Ni(CO)_4$ by sodium borohydride. Cold trapped using liquid nitrogen	AAS with quartz tube burner	0.0005 $\mu\text{g/l}$	[524]
Palladium	Adsorbed onto liquid membrane or tri-N-octyl-amine	-	-	[530]
Polonium	Polonium electrodeposited from water onto carbon rod, stripped from rods and autoplated onto silver counting discs	Autoplating ^{209}Pu counted	-	[901, 902]
Plutonium	Pu co-precipitated with ferric hydroxide, precipitate dissolved in acid	Anion exchange chromatography	-	[903, 904]
Plutonium	Plutonium(IV) converted to xylenol orange complex on XAD-2 resin	α -ray spectrometry of resin	-	[905]
Rhenium	Adsorption on Deacidite FF anion exchange resin, elution of resin with 4 M nitric acid	Neutron activation analysis	0.06 ng/l (15 ml sample)	[539]

Table 5.12. (continued)

Cation	Pre-concentration method	Analytical finish	Detection limit	Reference
Rubidium	Rubidium co-precipitated with $\text{Ni}_3\text{K}_2[\text{Fe}(\text{CN})_6]_2$	X-ray fluorescence spectrometry	2 $\mu\text{g/l}$ absolute	[541]
Selenium	Selenium converted to 3,3-diaminobenzidine pielselenol, which is extracted into toluene and back-extracted into 0.5 M hydrochloric acid	Complex deposited on a mercury electrode at -0.45 V	0.01 $\mu\text{g Se}$ absolute	[542]
Selenium	Selenium(IV) ammonium pyrrolidine diethyldithiocarbamate complex adsorbed onto C_{18} bonded silica, then desorbed	Graphite furnace AAS	7 ng/l	[860]
Selenium	Conversion of selenium into selenium hydride	Selenium hydride swept into quartz tube at 400°C , analysed by hydride generation	20 ng/l	[906]
Selenium	Selenium co-precipitated with $\text{Fe}(\text{OH})_3$, precipitate dissolved in hydrochloric acid, converted to 5-nitro-piazselenol	Graphite furnace AAS	5 ng/l	[907]
Selenium	Selenium complexed with 4-nitro- <i>o</i> -phenylenediamine, extracted into toluene	Gas chromatography with electron capture detector	-	[555]
Selenium	Adsorption colloid flotation	Gas chromatography	-	[517, 546]
Silver	Silver pre-concentrated on Deacidite FF IP anion exchange resin, eluted with thiourea	Spectrophotometry of methylene blue complex	< 40 ng/l	[559]
Silver	Silver complexed with ammonium dithiophosphate and <i>o,o</i> diethylester then adsorbed onto carbon, silver desorbed with nitric acid	Neutron activation analysis	0.3 ng/l 0.0003 $\mu\text{g/l}$	[908]
Strontium	Strontium complexed with 1-phenyl-3-methyl-4-benzoyl-5-pyrazone	Electrothermal AAS	0.007 ng/l	[909]
Technetium	Pre-concentrated on anion exchange column	AAS	3 mBq/l	[910]

Table 5.12. (continued)

Cation	Pre-concentration method	Analytical finish	Detection limit	Reference
Technetium	Co-precipitation with $\text{Fe}(\text{OH})_3$	Inductively coupled plasma mass spectrometry	-	[911]
Tellurium	Tellurium coprecipitated with $\text{Mg}(\text{OH})_2$	AAS	0.5 pmol/l	[863]
Tin	Tin complexed with sodium diethyldithio carbamate	Spectrophotometry	-	[588]
Tin	Tin adsorbed onto Dowex 1-X8 anion exchange column, desorbed with 2 M nitric acid	Spectrophotometry with catechol violet	-	[912]
Uranium	Liquid-liquid extraction of uranium styrylacryloyldioxamic acid complex	Spectrophotometry	1 mg/l	[590]
Uranium	Formation of trioctyl phosphine complex, ether extraction	Fluorimetric and spectrophotometry	-	[913, 914]
Uranium	Chloroform extraction of uranium quinoline complex	Electroanalytical	-	[291]
Uranium	Uranium adsorbed as azide on basic ion exchange column, uranium desorbed with 1 M hydrochloric acid	Spectrophotometry	-	[915]
Uranium	Uranium adsorbed on bismuthol(II) modified anion exchange resin, desorbed with 0.1 M cysteine	Fluorometry	-	[916]
Uranium	Uranium, by square wave adsorptive stripping voltammetry	-	0.1 $\mu\text{mol/l}$	[592]
Uranium	Uranium coprecipitated with aluminium phosphate, precipitate dissolved in nitric acid	Fission track method	-	[917]
Uranium	Adsorption onto colloidal ferric hydroxide	Spectrophotometric at 550 nm by Rhodamine B method	-	[918]
Vanadium	Vanadium thiocyanate complex adsorbed on Dowex 1-X8 anion exchange resin, desorbed with nitric acid	Spectrophotometric at 545 nm by 2-pyridylazoresorcinol method or AAS	-	[597, 602, 919]
Vanadium	Vanadium complexed with tetraphenyl-arsonium chloride and tetramethylene dithio-carbamate, extracted with chloroform	Graphite furnace AAS	< 0.5 $\mu\text{g/l}$	[598]

Table 5.12. (continued)

Cation	Pre-concentration method	Analytical finish	Detection limit	Reference
Vanadium	Absorptive stripping voltammetry	–	70 pM	[601]
Vanadium	Co-precipitation with ferric hydroxide, cobalt ammonium pyrrolidine dithiocarbamate or ammonium pyrrolidine dithiocarbamate	Miscellaneous	–	[920]
Zinc	Zinc collected on methyl capryl ammonium chloride coated C ₁₈ resin	Graphite furnace AAS	2.4 µg/l	[617]
Zinc	Zinc adsorbed on Chelex-100 resin, desorbed with nitric acid	Graphite furnace AAS	0.5 µg/l	[618]
Zinc	Complexation with <i>p</i> -tosyl-8-aminoquinoline and adsorption on cation exchange resin	Spectrofluorimetry	0.1 nM absolute	[609]
Zinc	Formation of zinc ammonium pyrrolidine dithiocarbamate complex	Cathodic stripping voltammetry	–	[619]
Zirconium	Co-precipitation with ferric hydroxide	Spectrophotometry by alizarin R method	–	[608, 922]

Source: Author's own files

Table 5.13. Pre-concentration of metals in sea water chelation-solvent extraction techniques followed by direct AAS and graphite furnace AAS

Metals	Chelating agent	Solvent	Detection limit* ($\mu\text{g/l}$)		Reference
Direct AAS					
Mn, Fe, Co, Ni, Zn, Pb, Cu	Hexahydroazepine-1- carbodithioate	Butylacetate	Mn	0.2	[923]
			Fe	1.5	
			Co	0.6	
			Ni	0.6	
			Zn	0.4	
			Pb	2.6	
Fe, Pb, Cd, Co, Ni, Cr, Mn, Zn, Cu	Diethyldithiocarbamate	MIBK or xylene			[924]
Fe, Cu	Ammonium pyrrolidinedithiocarbamate	MIBK	Cu	< 1	[925]
			Fe	< 1	
Graphite furnace AAS					
Cu, Ni, Cd	Ammonium pyrrolidinedithiocarbamate				[518]
Ag, Cd, Cr, Cu, Fe, Ni, Pb, Zn	Ammonium pyrrolidinedithiocarbamate	MIBK	Ag	0.02	[926]
			Cd	0.03	
			Cr	0.05	
			Cu	0.05	
			Fe	0.20	
			Ni	0.10	
			Pb	0.03	
			Zn	0.03	
Cu, Cd, Zn, Ni	Diethyldithiocarbamate plus Ammonium pyrrolidinedithiocarbamate	Chloroform	Cu	1.0	[122]
			Cd	0.2	
			Zn	2.0	
			Ni	10.0	
Cd, Pb, Ni, Cu, Zn	Ammonium pyrrolidinedithiocarbamate plus diethyldithiocarbamate	Freon	No stated		[124]
Cd, Cu, Fe	Ammonium pyrrolidinedithiocarbamate plus diethyldithiocarbamate	Freon	Not stated		[119]
Cd, Zn, Pb, Cu, Fe, Mn, Co, Cr, Ni	Ammonium pyrrolidine-N-carbodithioate plus 8-hydroxyquinoline	MIBK	Fe	0.08	[121]
			Cu	0.10	
			Pb	0.06	
			Cd	0.02	
			Zn	0.34	
Cd, Zn, Pb, Fe, Mn, Cu, Ni, Co, Cr,	Dithiocarbamate	MIBK	Not stated		[736]

Table 5.13. (continued)

Metals	Chelating agent	Solvent	Detection limit* ($\mu\text{g/l}$)	Reference	
Cd, Co, Cu, Fe, Mn, Ni, Pb, Zn	Ammonium pyrrolidinedithiocarbamate	Chloroform	Cd	< 0.0001	[879]
			Cu	< 0.012	
			Fe	< 0.02	
			Mn	< 0.004	
			Ni	< 0.012	
			Pb	< 0.016	
Cd, Co, Cu, Fe, Mn, Ni, Pb, Zn	Ammonium pyrrolidinedithiocarbamate	Chloroform	Zn	< 0.08	[879]
			Cd	0.02	
			Cu	0.24	
			Fe	0.24	
			Mn	0.02	
			Ni	0.08	
Mn, Cd	Ammonium pyrrolidinedithiocarbamate and diethylammonium dithylthiocarbamate	Freon	Mn	0.07	[448]
			Cd	0.027	
Cd, Cu, Fe, Pb, Ni, Zn	Ammonium pyrrolidinedithiocarbamate and diethylammonium dithylthiocarbamate	Freon	Not quoted		[927]
Bi	Ammonium pyrrolidinedithiocarbamate	Xylene	0.003	[95]	
Pb, Cd, Co, Cu, Sn, As, Mo	Ammonium pyrrolidinedithiocarbamate	-	-		[666]
Cd, Co, Cu, Ni, Pb, Zn	Sodium bis (2-hydroxyethyl) dithiocarbamate	-	-		[928]
Cu, Bi, Cd, Zn, Pb	Diethyl and dibutyl dithio- phosphate	Carbon tetrachlo- ride	Cu	0.6	[667]
			Bi	0.5	
			Cd	0.8	
			Zn	0.8	
			Pb	0.5	

Source: Author's own files

that the resin also adsorbs small but significant amounts of inorganic ions from seawater, and is therefore unsuitable for use in studies on the speciation of trace metals.

Latouche et al. [855] have reviewed trace metal speciation in seawater.

Baskaran et al. [856] have discussed the rapid extraction and determination of thorium, lead, and radium species from large volumes of seawater.

Magni et al. [857] studied the optimisation of the extraction of metal-humic acid complexes from marine sediments. Polyarylamide gels have been

Table 5.14. Application of Chelex-100 resin to the pre-concentration of metals in seawater prior to analysis by graphite atomic spectrometry

Elements	Concentration factor	Eluent	Detection limit ($\mu\text{g/l}$)	Reference
Cd, Co, Cu, Fe, Mn, Ni, Pb, Zn	100:1	2.5 M nitric acid	subnanogram	[129]
Cu, Cd, Zn, Ni,	120:1	2 M nitric acid	Cu 0.006 Cd 0.006 Zn 0.015 Ni 0.015	[122]
Cd, Zn, Pb, Cu, Fe, Mn, Co, Cr, Ni	20:1	2.5 M nitric acid	Not stated	[121]
Cd, Pb, Ni, Cu, Zn,	100:1	2.5 M nitric acid	Cd 0.01 Pb 0.16–0.28 Ni 0.24–0.68 Cu 0.6 Zn 1.8	[821]
Cr, Cu, Mn	–	–	–	[929]
Cd, Cu, Ni, Pb	–	Nitric acid (pH 5) plus 7.5 M ammonium acetate	–	[124]

Source: Author's own files

Table 5.15. Miscellaneous solids used in the pre-concentration of cations in seawater

Cation	Solid adsorbent	Analytical finish	Detection limit ($\mu\text{g/l}$)	Reference
Mo, V	Cellulose phosphate	ICPAES	–	[930]
Se(IV), Se(VI)	Thiol cotton (subsequent desorption with nitric and magnesium nitrite)	Cathodic stripping voltammetry	Se(VI) 0.009 Se 0.018	[931]
Cd, Co, Cu, Fe, Mn, Ni, Pb, Zn	Maleic acid/ammonium hydroxide buffer system	–	–	[932]
Heavy metals	Silica gel	X-ray fluorescence	–	[813]

Source: Author's own files

used as in situ probes for the determination of trace metals in sediment pore water [858].

5.74.19

Metal Preconcentration

The considerable difficulty of trace element analysis in a high salt matrix such as seawater, estuarine water, or brine is clearly reflected in the literature. The extremely high concentrations of the alkali metals, alkaline earth metals, and

Table 5.16. Applications of co-precipitating agents to the pre-concentration of cations in seawater

Cation	Solid adsorbent	Analytical finish	Detection limit ($\mu\text{g/l}$)	Reference
Cd, Zn, Mn, Co, Cu, Ni, V, Cr, Si, B, Be, Ca, Mg, Li, lanthanides	Magnesium hydroxide	ICP-AES	< 4 (200 ml sample)	[933]
Hg, Pb, Cd	Copper sulfide	AAS	–	[685]
Cd, Cu, Pb	Palladium salts	AAS	–	[664]
Miscellaneous trace metals	Maleic acid/ammonium hydroxide buffer system	–	–	[934]
Ag(I), Cd(II), Cr(III), Cu(II), Mn(II), Th(IV), U(VI), Zr(IV)	Lead phosphate	Neutron activation analysis	Ag 0.2 Cd 3.2–3.8 Cr 7 Cu 2.7 Mn 0.07–1.7 Th 0.3–0.9 U 0.007–0.018 Zr 40 (100 ml sample)	[825]

Source: Author's own files

halogens, combined with the extremely low levels of the transition metals and other elements of interest, make direct analysis by most analytical techniques difficult or impossible.

Brief mention has been made, particularly in connection with the inductively coupled plasma atomic absorption spectrometric technique, of the need to preconcentrate seawater samples prior to the determination of metals, in order to achieve adequate detection limits.

A variety of preconcentration procedures has been used, including solvent extraction of metal chelates, coprecipitation, chelating ion exchange, adsorption onto other solids such as silica-bonded organic complexing agents, and liquid–liquid extraction.

An ideal method for the preconcentration of trace metals from natural waters should have the following characteristics: it should simultaneously allow isolation of the analyte from the matrix and yield an appropriate enrichment factor; it should be a simple process, requiring the introduction of few reagents in order to minimise contamination, hence producing a low sample blank and a correspondingly lower detection limit; and it should produce a final solution that is readily matrix-matched with solutions of the analytical calibration method.

Much work has been published on preconcentration techniques; this work is reviewed below.

Table 5.17. Miscellaneous supported chelators used for pre-concentrations in seawater

Element	Chelating agent	Solid adsorbent support	Analytic finish	Detection limit ($\mu\text{g/l}$)	Reference
Cd, Pb, Zn, Cu, Fe, Mn, Ni,	8-Hydroxyquinoline	Silica	AAS	Co 0.2 Fe 40 (50 ml samples)	[935]
Cd, Cu, Pb, Zn,	(3-mercapto propyl) trimethyl oxysilane	Silica	-	-	[936]
Ag(I), Au(III), Pd(II),	p-dimethyl-amino benzylidine-rhodamine	Silica	-	-	[937]
Cu, Ni, Cd	8-quinolinol	Silica	ICPAES	0.016–0.07	[938]
Fe, Co, Zn, Cs, Zr	Zirconium hexacyanoferrate(II)	Cation exchange resin	γ -spectrometry	-	[939]
Rare earths	Bis (2-ethyl-hexyl) hydrogen phosphate and 2-ethyl dihydrogen phosphate	C ₁₈ silica	ICPMS	-	[650]
Cd, Cu	Sodium diethyl dithiocarbamate	C ₁₈ silica	AAS	0.004–0.024	[283]
Hg, Pb	Tubular membrane	Dithiocarbamate	-	-	[93]
Cd, Cu, Mn, Ni, Pb, Zn	Chelamine resin	-	-	-	[941]
Ga, Ti, In	8-Hydroxyquinoline immobilised resin	-	ICPAES	0.001–0.004	[942]
Fe, Ni, Cu, Cd, Mo, Cr, V	Chelating	Silica	ICPAES	-	[943]

Source: Author's own files

Firstly, work on preconcentration methods for the single elements is reviewed in alphabetical order in Table 5.12.

Information on preconcentration of multicomponent mixtures is reviewed in Tables 5.13 to 5.18.

The benefits imparted by preconcentration to improved sensitivity are illustrated in the example of lead preconcentration on Chelex 100 resin [871, 872], followed by analysis by ICP–AES. Without preconcentration the best detection limit achievable is 60 ng/l, via direct nebulisation. When the Chelex 100 preconcentration step is included, the detection limit improves to 0.6 ng/l, i.e., 100 times better, which is a very important improvement achieved in the analysis of seawaters. Examination of Table 5.12 reveals that the following metals can be determined with detection limits in the 1–10 ng/l range: beryllium (0.6 ng/l),

Table 5.18. Applications of dithiocarbamate acid derivatives to the preconcentration of cations in seawater

Cations determined	Organic coprecipitant	Analytical finish	Detection limit ($\mu\text{g/l}$)	Reference
Hg, Au, Cu	Lead diethyldithiocarbamate	Neutron activation analysis		[820]
Cd, Co, Cu, Hg, Mn, Th, U, V, Zn	1) (1-(2-thiazolylazo)-2-naphthol) 2) Pyrrolidinedithiocarbamate 3) <i>N</i> -nitrosophenylhydroxylamine	Neutron activation analysis	$\mu\text{g/l}$ level	[944]
Heavy metals	Ammonium pyrrolidinedithiocarbamate	X-ray fluorescence	–	[945]

Source: Author's own files

bismuth (0.3 ng/l), cadmium (0.6 ng/l), indium (0.3 ng/l), tellurium (0.07 ng/l), lead (0.6 ng/l), mercury (0.1 ng/l), silver (0.3 ng/l), and nickel (0.5 ng/l). In every case but two, preconcentration involves the solvent extraction of a metal complex of the metal followed by AAS. Without preconcentration, detection limits would be 50 to 100 times higher. Elements for which preconcentration achieves detection limits in the 10–100 ng/l range include cobalt (70 ng/l), iron (30 ng/l), copper (10 ng/l), manganese (30 ng/l), molybdenum (10 000 ng/l), rubidium (1000 $\mu\text{g/l}$), selenium (5 ng/l), uranium (20 $\mu\text{g/l}$), vanadium (500 ng/l), zinc (500 ng/l), antimony (50 ng/l), and chromium (1.6 ng/l).

5.74.20

Miscellaneous

Worsfold et al. [960] have discussed the application of flow injection analysis with chemiluminescence detection for the shipboard monitoring of trace metals.

Achterberg et al. [961] have described an electrochemical monitor for near real-time determination of dissolved trace metals in marine waters, and also in surface seawater [962].

References

1. Lin B, Wu H, Cai Z (1987) *Yuanzineng Kexue Jishu* 21:447
2. Ishibashi M, Kawai T (1952) *Nippon Kagaku Zasshi* 73:380
3. Ishibashi M, Motojima K (1952) *Nippon Kagaku Zasshi* 73:491
4. Motojimi K (1955) *Nippon Kagaku Zasshi* 76:902
5. Japan Industrial Standard (JIS) (1974) K0102
6. Shull KE, Guthan GR (1967) *J Am Water Works Assoc* 59:1456

7. Titkova NF (1963) Nauchn Doklady Vyssh Shk, Biol Nauki **126**:127
8. Simons LH, Monaghan PH, Taggart MS (1953) Anal Chem **25**:989
9. Sackett W, Arrhenius G (1962) Geochim Cosmochim Acta **26**:955
10. Nishikawa Y, Hiraki K, Morishige K, Tsuchiyama A, Shigematsu T (1968) Bunseki Kagaku **17**:1092
11. Shigematsu T, Nishikawa Y, Hiraki K, Nagano N (1970) Bunseki Kagaku **19**:551
12. Hydes DJ, Liss PS (1976) Analyst **101**:922
13. Morishige K, Hiraki K, Nishikawa K, Shigematsu T (1978) Bunseki Kagaku **27**:109
14. Ishibashi M, Fujinaga T (1952) Nippon Kagaku Zasshi **73**:783
15. Hsu DY, Pipes WO (1972) Environ Sci Tech **6**:645
16. Kahn HL (1973) Environ Anal Chem **3**:121
17. Barnes RA (1975) Chem Geol **15**:177
18. Lee ML, Burrell DC (1973) Anal Chim Acta **66**:245
19. Gosink TA (1975) Anal Chem **47**:165
20. Pavlenko LI, Safronova NS (1975) Zh Anal Khim **30**:775
21. Fujinaga T, Kusaka R, Koyama M et al. (1973) J Radioanal Chem **13**:301
22. Buono JA, Karin RW, Fasching JL (1975) Anal Chim Acta **80**:327
23. Dougan WK, Wilson AL (1974) Analyst **99**:413
24. Dale T, Henriksen A (1975) Vatten **31**:91
25. Henriksen A, Bergmann-Paulsen LM (1975) Vatten **31**:339
26. Korenaga T, Motomizu S, Toei K (1980) Analyst **105**:328
27. Howard AG, Coxhead AJ, Potter A, Watt AP (1986) Analyst **111**:1379
28. Salgado Ordonez M, Garcia de Torres A, Cano Pavon JM (1985) Talanta **32**:887
29. Spencer DW, Sachs PL (1969) Atomic Absorption Newsletter **8**:65
30. Van den Berg CMG, Murphy K, Riley JP (1986) Anal Chim Acta **188**:177
31. Prochazkova L (1964) Anal Chem **36**:865
32. Johnston R (1966) Journal of the International Conference on Exploration of the Sea **N**:11
33. Strickland JDH, Austin KH (1959) Journal of the International Council for Exploration of the Sea **24**:446
34. Newell BS (1967) J Mar Biol Assoc **47**:271
35. Emmet RT (1968) Naval Ship Research and Development Centre, Report 2570
36. Koroleff F (1970) Interlaboratory Report **3**:19
37. Solorzano L (1969) Limnol Oceanogr **14**:799
38. Head PC (1971) Deep-Sea Res **18**:531
39. Grasshoff K, Johansson H (1972) Journal of the International Council for Exploration of the Sea **34**:516
40. Liddicoat MI, Tibbits S, Butler EI (1975) Limnol Oceanogr **20**:131
41. Slawyk G, Maclsaac JJ (1972) Deep-Sea Res **19**:521
42. Benesch R, Mangelsdorf P (1972) Helgolander wiss Meeresunters **23**:365
43. Haywood JE, Huyser DJ (1970) Water Res **4**:695
44. Matsunaga K, Nishimura M (1971) Japan Analyst **29**:993
45. Richards FA, Kletsch RA (1964) In: Maysho Y, Kryama T (eds) Recent researches in the fields of hydrosphere, atmosphere, and nuclear geochemistry. Maruzen, Tokyo, pp 65, 81
46. Matsunaga K, Nishimura M (1974) Anal Chim Acta **73**:204
47. Berg BR, Abdullah MI (1977) Water Res **11**:637
48. Brzezinski MA (1987) Mar Chem **20**:277
49. Le Corre P, Treguer P (1978) Journal of the International Council for Exploration of the Sea **38**:147

50. Grasshoff K, Johannsson H (1972) *Journal of the International Council for Exploration of the Sea* **34**:516
51. Truesdale VW (1971) *Analyst* **96**:584
52. Selmer JS, Sorenson F (1986) *Appl Environ Microbiol* **52**:577
53. Willason SW, Johnson KS (1986) *Mar Biol* **91**:285
54. McLean JD, Stenger VA, Reim RE, Long MW, Hiller TA (1978) *Anal Chem* **50**:1309
55. Gilbert TR, Clay AM (1973) *Anal Chem* **45**:1757
56. Hampson BL (1977) *Water Res* **11**:305
57. Gardner WS, St John PA (1991) *Anal Chem* **63**:537
58. Gardner WS, Herche LR, ST John PA, Seitzinger SP (1991) *Anal Chem* **63**:1838
59. Sturgeon RE, Willie SN, Berman SS (1985) *Anal Chem* **57**:2311
60. Bertine KK, Lee DS (1981) Trace metals in seawater. In: Wong CS et al. (eds) *Proceedings of a NATO advanced research institute on trace metals in seawater, Sicily, Italy*. Plenum Press, New York
61. Afvanse YA, Ryabmin A, Azhipa L (1975) *Zhur Anal Chem* **30**:1830
62. Arsenic in Potable and Seawater by Spectrophotometry, 1978, Tentative Method, (1980) Department of the Environment/National Water Council Standing Committee of Analysts, HMSO, London
63. Howard AG, Comber SDW (1992) *Microchim Acta* **109**:27
64. Bermejo-Barrera P, Barciela-Alonso MC, Ferrón-Novais M, Bermejo-Barrera A (1995) *J Anal At Spectrom* **10**: 247
65. Burton JD (1981) Trace metals in seawater. In: Wong CS et al. (eds) *Proceedings of a NATO advanced research institute on trace metals in seawater, Sicily, Italy*. Plenum Press, New York
66. Ryabinum AI, Romanov AS, Khatakov SL, Kist AA, Khamidove R (1972) *Zhur Anal Chem* **27**:94
67. Yusov AN, Ishan ZB (1994) *J Radioanal Nucl Chem* **179**:277
68. Creed JT, Magnusson ML, Brockhoff CA, Chamberlain I, Sivaganesan M (1996) *J Anal At Spectrom* **11**:505
69. Klane B, Blum JD (1999) *Anal Chem* **71**:1408
70. Jaya S, Rao TP, Rao GP (1987) *Talanta* **34**:574
71. Hua C, Jagner D, Renman L (1987) *Anal Chim Acta* **207**:263
72. Huiliang H, Jagner D, Renum L (1988) *Anal Chim Acta* **207**:37
73. Becker NSC, McRae VM, Smith JD (1985) *Anal Chim Acta* **173**:361
74. Chow TJ, Goldberg ED (1961) *Geochim Cosmochim Acta* **20**:192
75. Bishop JKB (1990) *Anal Chem* **62**:553
76. Epstein MS, Zander AT (1979) *Anal Chem* **51**:915
77. Roe KK, Froelich PN (1984) *Anal Chem* **56**:2724
78. Dehairs F, De Bondt M, Baeyens W, Van dr Winkle P, Hoenig M (1987) *Anal Chim Acta* **196**:33
79. Okutani T, Tsuruta Y, Sakuragawa (1993) *Anal Chem* **65**:1273
80. Matahara G (1974) *Bunseki Kagaku* **23**:878
81. Yamamuchi N, Nishida T, Nishida H (1989) *Bunseki Kagaku* **34**:48
82. Tao H, Imazawa T, Myazaki, Bansho K (1987) *Bunseki Kagaku* **36**:447
83. Nishida H (1990) *Bunseki Kagaku* **39**:805
84. Fleet B, Liberty KV, Wets TS (1970) *Talanta* **17**:203
85. Terashima S (1973) *Bunseki Kagaku* **22**:1317
86. Matsuzaki K (1975) *Bunseki Kagaku* **24**:442
87. Terashima S (1982) *Bunseki Kagaku* **31**:727
88. Asani T, Fukuzawa F (1985) *Soil Sci Plant Nutr* **31**:43

89. Shimomura S, Morita H, Kuboto M (1986) *Bunseki Kagaku* **25**:539
90. Nakajima R (1978) *Bunseki Kagaku* **37**:185
91. Paschal DC, Bailey GG (1986) *Atom Spectrosc* **7**:1
92. Schmidt WF, Diotc F (1987) *Fresen Z Anal Chem* **326**:40
93. Elles WG, Hodge VR, Darley DA, Jones CL (1988) *Atom Spectrosc* **9**:181
94. Shon X-Q, Yian Z, Ni Z-M (1989) *Anal Chim Acta* **217**:271
95. Shijo Y, Mitsuhashi M, Shimizu T, Sakunai S (1992) *Analyst* **117**:1929
96. Soo LD (1982) *Anal Chem* **54**:1682
97. Gilbert TJ, Hume DN (1973) *Anal Chim Acta* **65**:451
98. Florence TM (1974) *J Electroanal Chem* **49**:255
99. Eskilsson H, Jaguer D (1982) *Anal Chim Acta* **138**:27
100. Gillain G, Duychaerts G, Distech A (1979) *Anal Chim Acta* **106**:23
101. Jagner D, Aren K (1978) *Anal Chim Acta* **100**:375
102. Danielsson LG, Jagner D, Josefson M, Westerlund S (1981) *Anal Chim Acta* **127**:147
103. Jagner D, Josefson M, Westerlund S (1981) *Anal Chim Acta* **128**:155
104. Portman JE, Riley JP (1966) *Anal Chim Acta* **34**:201
105. Koroleff F (1947) *Acta Chim Scand* **1**:503
106. Koroleff F (ed) (1980) *Proceedings of the 12th Conference of the Baltic Oceanographers, Leningrad*
107. Komorsky-Lovric S (1988) *Anal Chim Acta* **204**:161
108. Uppstroem LR (1968) *Anal Chim Acta* **43**:475
109. Hulthe P, Uppstroem LR, Oestling G (1970) *Anal Chim Acta* **51**: 31
110. Nicolson RA (1971) *Anal Chim Acta* **56**:147
111. Oshima M, Motomizu S, Toei K (1974) *Anal Chem* **56**:948
112. Marcantoncetos M, Gamba G, Mannier D (1973) *Anal Chim Acta* **67**:220
113. Horta TMTc, Curtins AJ (1977) *Anal Chim Acta* **96**:207
114. Tsaikov SP (1982) *Comptes Rendus De l'Academic Bulgare Des Science* **35**:61
115. Campbell WC, Ottaway JH (1977) *Analyst* **102**:495
116. Guevremont R (1980) *Anal Chem* **52**:1574
117. Guevremont R, Sturgeon RE, Berman SS (1980) *Anal Chim Acta* **115**:1633
118. Gardner J, Yates J (1979) In: *International conference on management and control of heavy metals in the environment. Water Research Centre, Stevenage Laboratory, Stevenage. CEP Consultants, Edinburgh, pp 427-430*
119. Danielsson LG, Magnusson B, Westerlund S (1978) *Anal Chim Acta* **98**:47
120. Batley GE, Farrah YJ (1978) *Anal Chim Acta* **99**:283
121. Sturgeon RE, Berman SS, Desauiniers JAH, Russell DS (1980) *Talanta* **27**:85
122. Bruland KW, Franks RP, Knauer GA, Martin JH (1979) *Anal Chim Acta* **105**:233
123. Smith RG Jr, Windom HL (1980) *Anal Chim Acta* **113**:39
124. Rasmussen L (1981) *Anal Chim Acta* **125**:117
125. Sturgeon RE, Berman SS, Desauiniers JAH, Mykytiuk AP, McLaren JW, Russell DS (1980) *Anal Chem* **52**:1585
126. Sperling KR (1978) *Anal Chem* **292**:113
127. Bengtsson M, Danielsson LG, Magnusson B (1979) *Anal Letters* **12**:1367
128. Sperling KR (1980) *Anal Chem* **301**:294
129. Kingston HM, Barnes IL, Brady TJ, Rains TC, Champ MA (1978) *Anal Chem* **50**:2064
130. Lund W, Larsen BV (1974) *Anal Chim Acta* **72**:57
131. Bately GE (1981) *Anal Chim Acta* **124**:121
132. Lundgren G, Lundmark L, Johansson G (1974) *Anal Chem* **46**:1028
133. Sperling KR (1977) *Fresen Z Anal Chem* **287**:23
134. Sperling KR (1980) *Fresen Z Anal Chem* **301**:294

135. Pruszkowska E, Carnrick GR, Slavin W (1983) *Anal Chem* **55**:182
136. Campbell WC, Ottaway JM (1977) *Analyst* **102**:495
137. Nakahara T, Chakrabarti CL (1979) *Anal Chim Acta* **104**:99
138. Brewer SW (1985) *Anal Chem* **57**:724
139. Knowles M (1987) Varian atomic absorption no AA 71 methods for the determination of cadmium in seawater with Zeeman background correction
140. Lum KR, Callaghan M (1986) *Anal Chim Acta* **187**:159
141. Zhang Z, Liu J, Lin R, Yang X, He H (1988) *Zhongshan Daxue Xuebao Ziran Kexuebao* **3**:109
142. Han H, Le X, Ni Z (1986) *Huanjing Huaxue* **5**:34
143. Stolzberg RJ (1977) *Anal Chim Acta* **92**:193
144. Yoshimura W, Uzawa Z (1987) *Bunseki Kagaku* **36**:367
145. Kounaves SP, Zirino A (1979) *Anal Chim Acta* **109**:327
146. Turner DR, Robinson SG, Whitfield M (1984) *Anal Chem* **56**:2387
147. Frigieri P, Trucco R, Ciaccolini I, Pampurini G (1980) *Analyst* **105**:651
148. Ganzerli L, Maggi L, Ciceri G (1987) *J Radioanal Nucl Chem* **114**:105
149. Shen Z, Li P (1986) *Fenxi Huaxue* **14**:55
150. Jagner D (1974) *Anal Chim Acta* **68**:83
151. Schmid RW, Reilley CN (1957) *Anal Chem* **29**:264
152. Ringbom AG, Pensar G, Wanninen E (1958) *Anal Chim Acta* **19**:525
153. Sadek FS, Schmid RW, Reilley CN (1959) *Talanta* **2**:38
154. Wanninen E (1961) *Talanta* **8**:355
155. Date Y, Toel K (1963) *Bull Chem Soc Japan* **36**:518
156. Culkin F, Cox RA (1966) *Deep-Sea Res* **13**:789
157. Tsunogai S, Nishimura M, Nakaya S (1968) *Talanta* **15**:385
158. Schwarzenbach G, Flaschka H (1969) *Complexometric titrations*, 2nd ed. Methuen, London
159. Horibe Y, Endo K, Tsuboto H (1974) *Earth Planet Sci Lett* **23**:136
160. Jagner D (1974) *Anal Chim Acta* **68**:83
161. Lebel J, Poisson A (1976) *Mar Chem* **4**:321
162. Krumgalz D, Holzer R (1980) *Limnol Oceanogr* **25**:367
163. Kanamori S, Ikegami H (1980) *J Oceanographic Soc Japan* **36**:177
164. Olson EJ, Chen CTA (1982) *Limnol Oceanogr* **27**:375
165. Smith MR, Cockram HP (1981) *Atom Spect* **2**:97
166. Dybus J (1969) *Clin Chim Acta* **23**:309
167. Blake WE, Bryant MWR, Waters A (1969) *Analyst* **94**:49
168. Whitfield M, Leyendekkers JW, Kerr JD (1969) *Anal Chim Acta* **45**:399
169. Brenner JB, Eldad H, Erlich S, Dalman N (1984) *Anal Chim Acta* **166**:51
170. Nakayama E, Kuwamoto T, Tokoro H, Fujinaka T (1981) *Anal Chim Acta* **131**:247
171. Cranston RE, Murray JW (1978) *Anal Chim Acta* **99**:275
172. Dejong GJ, Brinkman UAT (1978) *Anal Chim Acta* **98**:243
173. Gilbert TR, Clay AM (1973) *Anal Chim Acta* **67**:289
174. Crosman ST, Mueller TR (1975) *Anal Chim Acta* **75**:199
175. Batley GE, Matousek JP (1980) *Anal Chem* **52**:1570
176. Pankow JF, Junauer GE (1974) *Anal Chim Acta* **69**:97
177. Miyazaki A, Barnes RM (1981) *Anal Chem* **53**:364
178. Willie SN, Sturgeon RE, Berman SS (1983) *Anal Chem* **55**:981
179. Moffett JH (1987) Varian Atomic Absorption No. AA69, Measurement of Vanadium by Zeeman corrected graphite tube atomisation

180. Dubovenko LI, Zaposlozets QA, Pyatnitskii II (1986) *Khim Teknol Vody* 8:50
181. Siu WM, Bednas HE, Berman SS (1983) *Anal Chem* 55:473
182. Heumann KG (1980) *Toxicol Environ Chem Rev* 3:111
183. Colby BN, Rosecrance AE, Colby ME (1981) *Anal Chem* 53:1907
184. Mykytiuk AP, Russell DS, Sturgeon RE (1980) *Anal Chem* 52:1281
185. Sturgeon RE, Berman SS, Williw SN, Desauiniers JAH (1981) *Anal Chem* 53:2337
186. Boussemart M, Van den Berg CMG (1994) *Analyst* 119:1349
187. Chang CA, Patterson HH, Mayer LM, Bause DE (1980) *Anal Chem* 52:1264
188. Cranston RE, Murray JW (1980) *Limnol Oceanog* 25:1104
189. Mullins RL (1984) *Anal Chim Acta* 165:97
190. Sandell EB (1959) *Calorimetric determination of traces of metals*. Interscience, New York
191. Marchart H (1984) *Anal Chim Acta* 30:11
192. Willems GJ, de Ranter CJ (1974) *Anal Chim Acta* 68:111
193. Myasoedova GV, Savvin SG (1982) *Zh Anal Khim* 37:499
194. Leyden DE, Wegscheider W (1981) *Anal Chem* 53:1059
195. Ahern F, Eckert JM, Payne NC, Williams KL (1985) *Anal Chim Acta* 175:147
196. Posta J, Alimonti A, Petrucci F, Caroli S (1996) *Anal Chim Acta* 325:185
197. Mugo RK, Orlans KJ (1992) *Anal Chim Acta* 271:1
198. Nakayama E, Kuwamoto H, Tokoro H, Tsurubo S, Fujinaga T (1981) *Anal Chim Acta* 130:289
199. Grimaud D, Michard G (1974) *Mar Chem* 2:229
200. Nakayama E, Kuwamoto H, Tokoro H, Tsurubo S, Fujinaga T (1981) *Anal Chim Acta* 130:401
201. Nakayama E, Kuwamoto H, Tokoro H, Tsurubo S, Fujinaga T (1981) *Anal Chim Acta* 131:247
202. Ishibashi M, Shigematsu T (1950) *Bulletin of the Institute of Chemical Research Kyoto University* 23:59
203. Cheucas L, Riley JP (1966) *Anal Chim Acta* 35:240
204. Fukai R (1967) *Nature* 213:901
205. Fukai R, Vas D (1967) *J Oceanographic Society Japan* 23:298
206. Kuwamoto T, Murai S (1970) Preliminary report of the Hakuho-maru cruise KH-68-4. Ocean Research Institute, University of Tokyo, Tokyo p 72
207. Yamamoto T, Kadowski S, Carpenter JH (1974) *Geochem Journal* 8:123
208. Bowen HJM (1966) *Trace elements in biochemistry*. Academic Press, London
209. Kendrick MJ, May MT, Plishka MJ, Robinson KD (1992) *Metals in biological systems*. Ellis Harwood, Chichester pp 71–79
210. Knauer GA, Martin JH, Gordon RM (1982) *Nature* 297:49
211. Bruland KW (1983) *Trace elements in seawater*. In: Riley JP, Chester R (eds) *Chemical oceanography*, vol 8. Academic Press, London
212. Fukai R, Murray CN (1973) Environmental behaviour of radiocobalt and radiosilver released from nuclear power stations into aquatic systems. In: *Environmental behaviour of radionuclides released in the nuclear industry*. IAEA, Vienna pp 217–242
213. Carvalho FP (1986) *Health Physics* 53:73
214. Nolan CV, Fowler SW, Teyssie JL (1992) *Mar Ecol-Prog Ser* 30:105
215. Turner DR, Whitfield M, Dickson A (1981) *Geochim Cosmochim Acta* 45:855
216. Zhang H, van den Berg CMG, Wollast R (1990) *Mar Chem* 28:285
217. Donat JR, Bruland KW (1988) *Anal Chem* 60:240
218. Huyng Ngoc L, Whitehead NE (1986) *Oceanol Acta* 9:433
219. Jickells TD, Burton JD (1988) *Mar Chem* 23:131

220. Zhang H, Wollast R (1990) Distributions of dissolved cobalt and nickel in the Rhone and the Gulf of Lyons. In: Martin JM, Barth H (eds) Water pollution research report 20, ERO 2000, 2nd Workshop on the northwest mediterranean sea. Blanes, Spain pp 397–414
221. Murray JW (1975) *Geochim Cosmochim Acta* **39**:635
222. Balistrieri LS, Murray JW (1975) *Geochim Cosmochim Acta* **50**:2235
223. Kentner E, Zeitlin H (1970) *Anal Chim Acta* **49**:587
224. Motomizu S (1973) *Anal Chim Acta* **64**:217
225. Forster W, Zeitlin H (1966) *Anal Chim Acta* **34**:211
226. Riley J, Topping G (1969) *Anal Chim Acta* **44**:234
227. Armitage B, Zeitlin H (1971) *Anal Chim Acta* **53**:47
228. Going J, Wesenberg G, Andrejat G (1976) *Anal Chim Acta* **81**:349
229. Korkisch J, Sorio A (1975) *Anal Chim Acta* **79**:207
230. Gurtler O (1977) *Fresen Z Anal Chem* **284**:206
231. Harvey BR, Dutton JWR (1973) *Anal Chim Acta* **67**:377
232. Kouimtzis TA, Apostolopoulou C, Staphilakis I (1980) *Anal Chim Acta* **113**:185
233. Vasilikiotis G, Kouimtzis Th, Apostolopoulou C, Voulgaropoulos (1974) *Anal Chim Acta* **70**:319
234. Isshiki K, Nakayama E (1987) *Anal Chem* **59**:291
235. Spencer CP (1957) *J Gen Microbiol* **16**:282
236. Johnston R (1962) *J Mar Biolog Assoc* **43**:427
237. Johnston R (1964) *J Mar Biolog Assoc* **44**:87
238. Barber RT, Ryther JH (1969) *J Exploratory Marine Biol* **3**:191
239. Danielsson LG (1980) *Mar Chem* **8**:199
240. Malahoff A, Kolotyckina IY, Shipgun LK (1996) *Analyst* **121**:1037
241. Yuzefovsky A, Leonardo RF, Wang M, Michel RG (1994) *J Anal Atom Spectrosc* **9**:1195
242. Boyle EA, Handy B, van Green A (1987) *Anal Chem* **59**:1499
243. Sakamoto N private communication
244. Hirata S, Hashimoto Y, Aihara M, Mallika GV (1996) *Fresen J Anal Chem* **355**:676
245. Vega M, Van den Berg CMG (1997) *Anal Chem* **69**:874
246. Sylva RN (1976) *Water Res* **10**:789
247. Sunda WG, Hanson AK (1987) *Limnol Oceanog* **32**:537
248. Sunda WG, Lewis JM (1978) *Limnol Oceanog* **23**:870
249. Sunda WG, Gillespie PA (1979) *J Mar Res* **27**:761
250. Lewin J, Chen CH (1971) *Limnol Oceanog* **16**:670
251. Lewis AG, Whitfield RH, Ramnarine A (1972) *Mar Biol* **17**:215
252. Davey EW, Morgan MJ, Erickson SJ (1973) *Limnol Oceanog* **18**:993
253. Prakash A, Rashid MA, Jensen A, Subba Rao DV (1973) *Limnol Oceanog* **18**:516
254. Gnassia-Barelli M, Romero M, Laumond F, Pesando D (1978) *Mar Biol* **47**:15
255. Hongve D, Skogheim OK, Hindar A, Abrahamsen H (1980) *Bull Environ Contam Toxicol* **25**:594
256. Fisher NS, Frood D (1980) *Mar Biol* **59**:85
257. Sunda W, Guillard RRL (1976) *J Mar Res* **34**:511
258. Anderson DM, Morel FM (1978) *Limnol Oceanog* **23**:283
259. Murphy LS, Guillard RRL, Gavis J (1980) Evolution of resistant phytoplankton strains through exposure to marine pollutants. In: Mayer GF (ed) *Ecological stress and the new york blight: science and management*. Estuarine Research Foundation, Columbia, SC, USA, pp 401–412
260. Jackson GA, Morgan JJ (1978) *Limnol Oceanog* **23**:268
261. Chester R, Stoner JH (1974) *Mar Chem* **2**:17

262. Alberts JJ, Leyden DE, Patterson TA (1976) *Mar Chem* **4**:51
263. Boyle FA, Sclater FR, Edmond JM (1977) *Earth Planet Sci Lett* **37**:38
264. Winlom HL, Smith RG (1979) *Mar Chem* **7**:157
265. Zirino A, Yamaoto S (1972) *Limnol Oceanog* **17**:661
266. Stumm W, Morgan JJ (1981) *Aquatic chemistry: an introduction emphasizing chemical equilibria in natural waters*, 2nd edn. Wiley, New York
267. Sibley TH, Morgan JJ (1975) Equilibrium speciation of trace metals in freshwater-seawater mixtures. In: Hutchinson HC (ed) *Proceedings of international conference on heavy metals in the environment*, University of Toronto, Toronto, Ontario pp 310-338
268. Pagenkopf GK, Russo RC, Thurston RV (1974) *Journal of the Fisheries Research Board of Canada* **31**:462
269. Shuman MS, Woodward GP (1973) *Anal Chem* **45**:2032
270. Chau R, Lum-Shue-Chan K (1974) *Water Res* **8**:383
271. Campbell PGC, Blisson M, Gagne R, Tessior A (1977) *Anal Chem* **49**:2358
272. Stiff MJ (1971) *Water Res* **5**:585
273. Batley GE, Florence TM (1976) *Anal Lett* **9**:379
274. Plasvic M, Krznacic D, Branica M (1982) *Mar Chem* **11**:17
275. Van den Berg CMG (1982) *Mar Chem* **11**:323
276. Florence TM, Batley GE (1976) *Talanta* **23**:179
277. Figura P, McDuffie B (1979) *Anal Chem* **51**:120
278. Ruzic I (1982) *Anal Chim Acta* **140**:99
279. Waite TD, Morel FMM (1983) *Anal Chem* **55**:1268
280. Cabon JY, Le Bihan A (1987) *Anal Chim Acta* **198**:87
281. Cabon JY (1987) *Anal Chim Acta* **198**:103
282. Nishoika H, Maeda Y, Azumis T (1986) *Nippon Kaisui Gakkashi* **40**:100
283. Wang M, Yuzetovsky AJ, Michel RG (1993) *Microchem J* **48**:326
284. Tasinski R, Trachtenberg I, Andrychuk D (1974) *Anal Chem* **46**:364
285. De Marco R (1994) *Anal Chem* **66**:3202
286. Abraham J, Winpe M, Ryan DE (1969) *Anal Chim Acta* **48**:431
287. Muzzarelli RAA, Roccheti R (1974) *Anal Chim Acta* **69**:35
288. Gukens J (1987) *Ion Selective Electrode Review* **9**:127
289. Westall JC, Morel FMM, Hume DN (1979) *Anal Chem* **51**:2106
290. Lewenstam A, Hulanicki A, Ghali E (1990) In: Ivanaska I et al. (eds) *Contemporary electron chemistry*. Plenum Press, New York
291. Milner GWC, Wilson JD, Barnett GA (1961) *Journal of Electro Anal Chem* **2**:25
292. Van den Berg CMG, Huang ZQ (1984) *Anal Chim Acta* **164**:209
293. Scarano G, Morelli F, Seritti A, Zirino A (1990) *Anal Chem* **62**:943
294. Quentel F, Elleouet C, Madec C (1994) *Electroanalysis* **6**:683
295. Wang J, Foster N, Armalis S, Larsen D, Zirino A, Olsen K (1995) *Anal Chim Acta* **310**:223
296. Garcia-Monco Carra R, Sanchez-Misiego A, Zirino A (1995) *Anal Chem* **67**:4484
297. Fairless C, Bard AJU (1973) *Anal Chem* **45**:2289
298. Abe T, Itoh K, Murozumi M (1977) *Bunseki Kagaku* **15**:65
299. Harvey BR (1978) *Anal Chem* **50**:1866
300. Virmani YP, Zeller EJ (1974) *Anal Chem* **46**:324
301. Zharikov VF, Senyavin MK (1970) *Trudy Gos Okean Inst* (101), Ref Zhur Khim 19GD (7), Abstract No 7G189
302. Marvin KT, Proctor RR, Neal RA (1970) *Limnol Oceanog* **15**:320
303. Wood AM, Evans DW, Alberts JJ (1983) *Mar Chem* **13**:305

304. Stolzberg RJ, Rosin D (1977) *Anal Chem* **49**:226
305. Giesy JP (1980) Cadmium interactions with naturally occurring ligands. In: Nriagu JC (ed) *Biogeochemistry of cadmium*, pt. 1. Wiley, New York, pp 237–256
306. Zorkin NG, Grill EV, Lewis AG (1986) *Anal Chim Acta* **183**:163
307. Zirino A, Healy ML (1970) *Limnol Oceanog* **15**:956
308. Bradford WL (1978) *Limnol Oceanog* **1**:757
309. Bilinski H, Huston R, Stumm W (1976) *Anal Chim Acta* **84**:157
310. O'Shea TA, Mancy KH (1976) *Anal Chem* **48**:1603
311. Duinker JC, Kramer CJM (1977) *Mar Chem* **5**:207
312. Piro A, Bernhard M, Branica M, Verzi M (1972) Radioactive contamination of the marine environment. Symposium proceedings, Seattle, WA, USA. IAEA Edition, Vienna, pp 287–304
313. Ernst R, Allen HE, Mancy KH (1975) *Water Res* **9**:969
314. Florence TM, Batley GB (1977) *Journal of Electro Anal Chem* **75**:791
315. Stumm W, Bilinski H (1973) *Advances in water pollution research*. Sixth international conference. Jerusalem, 1972. Pergamon, Oxford, p 39
316. Bubic S, Branica M (1973) *Thalassia Jugoslavia* **9**:47
317. Zirino A, Kounaves SP (1977) *Anal Chem* **49**:56
318. Zirino A, Kounaves SP (1979) *Anal Chem* **51**:592
319. Zirino A, Kounaves SP (1977) *Anal Chim Acta* **113**:79
320. Sheffrin N, Williams EE (1982) *Anal Proc* **19**:483
321. Jagner D, Granelli A (1976) *Anal Chim Acta* **83**:19
322. Jagner D (1978) *Anal Chem* **50**:1924
323. Jagner D, Aren K (1979) *Anal Chim Acta* **107**:29
324. Brooks RR, Presley BJ, Kaplan IR (1967) *Anal Chim Acta* **38**:321
325. Brooks RR, Presley BJ, Kaplan IR (1967) *Talanta* **14**:809
326. Shuman MS, Michael LC (1975) In: *Proceedings of the international conference on heavy metals in the environment*, vol 1. Wiley, New York, p 227
327. Shuman MS, Michael LC (1978) *Environ Sci Tech* **12**:1069
328. Odier M, Plichon V (1971) *Anal Chim Acta* **55**:209
329. Weiss HV, Kenis PR, Korkisch J, Steffan I (1979) *Anal Chim Acta* **104**:337
330. Van den Berg CMG (1984) *Anal Chim Acta* **164**:195
331. Turner DB, Robinson SG, Whitfield M (1984) *Anal Chem* **56**:2387
332. Sunda WG, Hanson AK (1987) *Limnol Oceanog* **32**:537
333. Andreae MO, Froelich P (1981) *Anal Chem* **53**:287
334. Falkner KK, Edmond JM (1990) *Anal Chem* **62**:1477
335. Pilipenko AT, Pavlova VK (1972) *Zh Anal Khim* **27**:1253
336. Matthews AD, Riley JP (1970) *Anal Chim Acta* **51**:287
337. Martin JH, Fitzwater SE (1988) *Nature* **331**:342
338. Martin JH, Gordon RM, Fitzwater SE, Broenkow WW (1989) *Deep-Sea Res* **36**:649
339. Martin JH, Gordon RM, Fitzwater SE (1990) *Nature* **345**:156
340. Martin JH, Gordon RM, Fitzwater SE (1990) *Global Biogeochemical Cycles* **4**:5
341. Martin JH (1991) *Nature* **353**:123
342. Betzer PR, Carder KL, Duce RA, Merrill JT, Tindale NW, Uematsu M, Costello DK, Young RW, Feely RA, Breland JA, Bernstein RE, Greco AM (1988) *Nature* **336**:568
343. Young RW, Karter K, Betzer PR (1991) *Global Biogeochemical Cycles* **5**:119
344. Broecker WS (1990) *Global Biogeochemical Cycles* **4**:13
345. Dugdale RC, Wilkinson FP (1990) *Global Biogeochemical Cycles* **4**:13
346. Zhuang G, Yi Z, Duce RA, Brown PR (1992) *Nature (London)* **355**:537
347. Rigin VL, Blotchin AJ (1977) *Zh Anal Khim* **32**:312

348. Pilipenko AT, Barovskii VA, Kalinichenko JE (1978) *Zh Anal Khim* **33**:1880
349. Obata H, Karatani H, Nakayama E (1993) *Anal Chem* **65**:1524
350. Shriadah MMA, Ohzeki K (1986) *Analyst* **111**:555
351. Blain S, Treguer P (1995) *Anal Chim Acta* **308**:425
352. Eirod VA, Johnson KS, Coale KH (1991) *Anal Chem* **63**:893
353. O'Sullivan DW, Hansson AK, Lester DR (1995) *Mar Chem* **49**:65
354. Hiirio K, Tanaka T, Sawada T (1972) *Japan Analyst* **21**:635
355. Moore RM (1981) Trace metals in seawater. In: Wong CS et al. (eds) *Proceedings of a NATO advanced research institute on trace metals in seawater, Sicily, Italy*. Plenum Press, New York
356. Brendel PJ, Luther III GW (1995) *Environ Sci Tech* **29**:751
357. Sharma GM, Du Bois HR (1978) *Anal Chem* **50**:516
358. Bolshov MA, Zybin AV, Koloshnikov VG, Vasnetsov MV (1981) *Spectrochim Acta* **36B**:345
359. Cheam V, Lechner J, Sekerka I, Desrosiers R (1994) *J Anal Atom Spectrosc* **9**:315
360. Ke C-B, Lin K-C (1999) *Anal Chem* **71**:1561
361. Frech W, Cedergren A (1977) *Anal Chim Acta* **88**:57
362. Halliday MC, Houghton C, Ottaway JM (1986) *Anal Chim Acta* **119**:67
363. Schaule BK, Patterson CC (1981) *Earth Planet Sci Lett* **54**:97
364. Hirao Y, Fukomoto K, Sugisaki H, Kimura K (1979) *Anal Chem* **51**:651
365. Torsi G, Desimoni E, Palmisano F, Sabbatini L (1981) *Anal Chim Acta* **124**:143
366. McLaren JW, Wheeler RC (1977) *Analyst* **102**:542
367. Adams MJ, Kirkbright GF, Rievnatana P (1977) *Atomic Absorption Newsletter* **14**:10
368. Culver B, Surles T (1976) *Anal Chem* **47**:920
369. Prithard MW, Reeves RD (1976) *Anal Chim Acta* **82**:103
370. Yasuda S, Kakihama H (1976) *Anal Chim Acta* **84**:291
371. Tessari G, Torsi G (1975) *Anal Chem* **47**:842
372. Sturgeon RE, Chakrabarti CL, Langford CN (1976) *Anal Chem* **48**:1792
373. Fernandez FJ, Manning DC (1971) *Atomic Absorption Newsletter* **10**:3
374. Ediger RD, Peterson G, Kerber JD (1974) *Atomic Absorption Newsletter* **13**:61
375. Ediger RD (1975) *Atomic Absorption Newsletter* **14**:127
376. Regan JGT, Warren J (1976) *Analyst* **101**:220
377. Frech W, Cedergren A (1977) *Anal Chim Acta* **88**:57
378. Manning DC, Slavin W (1978) *Anal Chem* **50**:1234
379. Lundgren G, Lundmark L, Johansson G (1974) *Anal Chem* **46**:1028
380. Scobbie R (1973) *Technical topics*. Varian Techtron, Springvale, Victoria, Australia
381. Donnelly TH, Ferguson J, Eccleston AJ (1975) *Appl Spectrosc* **29**:2
382. Shigematsu T, Matsui M, Fujino O, Kinoshita K (1975) *Anal Chim Acta* **76**:329
383. Branderberger H, Bader H (1967) *Atomic Absorption Newsletter* **6**:101
384. Lund W, Larsen BV (1974) *Anal Chim Acta* **70**:299
385. Lund W, Larsen BV (1974) *Anal Chim Acta* **72**:57
386. Lund W, Larsen BV, Gundersen N (1976) *Anal Chim Acta* **81**:319
387. Lund W, Thomassen Y, Doyle P (1977) *Anal Chim Acta* **93**:53
388. Fairless L, Bard AJ (1972) *Anal Lett* **5**:433
389. Fairless L, Bard AJ (1973) *Anal Chem* **45**:2289
390. Batley GE, Matousek JP (1977) *Anal Chem* **49**:2031
391. Jensen PO, Dolezal J, Langmyhr FJ (1975) *Anal Chim Acta* **72**:245
392. Newton MP, Chauvin JV, Davis DG (1973) *Anal Lett* **6**:89
393. Newton MP, Davis DG (1975) *Anal Chem* **47**:2003
394. Dawson JB, Ellis DJ, Hartley TF, Evans MEA, Metcalf KW (1974) *Analyst* **99**:602

395. Torsi G (1977) *Anal Chim (Rome)* **67**:557
396. Halliday MC, Houghton C, Ottaway JM (1980) *Anal Chim Acta* **119**:67
397. Ohta K, Suzuki M (1979) *Fresen Z Anal Chem* **298**:140
398. Sturgeon RE, Willie SN, Berman SS (1989) *Anal Chem* **61**:1867
399. Clem RG, MDI Application, University of California, Berkeley. *Laboratory Notes* **8**:1
400. Petrie LM, Baier RW (1978) *Anal Chem* **50**:351
401. Acebal SA, De Luca Rebello A (1983) *Anal Chim Acta* **148**:71
402. Quentel F, Madec C, Courtot-Coupez J (1988) *Water Res* **20**:325
403. Svensmark B (1987) *Anal Chim Acta* **197**:239
404. Wu Q, Batley GE (1995) *Anal Chim Acta* **309**:95
405. Garcia-Monco Carra R, Sanchez-Misiego A, Zirino A (1995) *Anal Chem* **67**:4484
406. Flegal AR, Stukas VJ (1987) *Mar Chem* **22**:163
407. Byrne RH (1981) *Nature* **290**:487
408. Scaule DM, Patterson CC (1981) Trace metals in seawater. In: Wong CS et al. (eds) *Proceedings of a NATO advanced research institute on trace metals in seawater, Sicily, Italy*. Plenum Press, New York
409. Benzwi N (1972) *Israel J Chem* **10**:967
410. Rona M, Schmuckler G (1973) *Talanta* **20**:237
411. Wiernik M, Amiel S (1970) *J Radioanal Chem* **5**:123
412. Das DK, Mazumdar M, Shome SC (1972) *Anal Chim Acta* **60**:439
413. Smith MR, Cockran HB (1981) *Atom Spectrosc* **2**:97
414. Pybus T (1969) *Anal Chim Acta* **23**:309
415. Anfält T, Granéli A *Anal Chim Acta* **86**:13
416. Stumm W, Morgan JJ (1970) *Aquatic chemistry*. Wiley Interscience, New York
417. Murray JW, Brewer PG (1977) In: Glasby GP (ed) *Marine manganese deposits*. Elsevier, Amsterdam, pp 291–325
418. Morgan JJ (1967) Chemical equilibria and kinetic properties of manganese in natural waters. In: Faust SD, Hunter JV (eds) *Principles and applications of water chemistry*, Wiley, New York, pp 561–624
419. Kessick MA, Morgan JJ (1975) *Environ Sci Tech* **9**:157
420. Stumm W, Giovanoli R (1976) *Chimica* **30**:423
421. Bryan GW, Hummerstone IG (1973) *J Mar Biol Assoc of the UK* **53**:705
422. Holliday LM, Liss PS (1976) *Estuar Coast Mar Sci* **4**:349
423. Evans DW, Cutshall NH, Cross FA, Wolfe DA (1977) *Estuar Coast Mar Sci* **5**:71
424. Sholkovitz ER (1978) *Earth Planet Sci Lett* **41**:77
425. Davison W (1976) *J Electroanal Chem* **72**:229
426. Davison W (1977) *Limnol Oceanogr* **22**:746
427. Olafsson J (1986) *Sci Total Environ* **49**:101
428. Brewer PG, Spencer DW (1971) *Limnol Oceanogr* **16**:107
429. Biddle VI, Wehry EL (1971) *Anal Chem* **50**:867
430. Sturgeon RE, German SS, Desaulniers A, Russell DS (1979) *Anal Chem* **51**:2364
431. Segar DA, Gonzalez JG (1972) *Anal Chim Acta* **58**:7
432. Klinkhammer GP (1980) *Anal Chem* **52**:117
433. McArthur JM (1977) *Anal Chim Acta* **93**:77
434. Hydes DJ (1980) *Anal Chem* **52**:959
435. Segar DA (1975) *Adv Chem Ser* **147**:56
436. Segar DA, Cantillo AY (1980) *Anal Chem* **52**:1766
437. Montgomery JR, Peterson GN (1980) *Anal Chim Acta* **117**:397
438. Manning DC, Slavin W (1978) *Anal Chem* **50**:1234
439. L'vov BV (1978) *Spectrochim Acta B* **33**:153

440. Segar DA, Cantillo AY (1976) *Spectrochimica Symposium*, American Society of Limnology and Oceanography **2**:171
441. Slavin W, Manning DC (1979) *Anal Chem* **51**:261
442. Manning DC, Slavin W (1980) *Anal Chim Acta* **118**:301
443. Slavin W, Manning DC (1980) *Spectrochim Acta B* **35**:701
444. Landing WM, Bruland KW (1980) *Earth Planet Sci Lett* **49**:45
445. Moore RM, Burton JD, Williams PJ le B, Young ML (1979) *Cosmochim Acta* **43**:919
446. Subramanian KS, Meranger JC (1979) *Int J Environ Anal Chem* **7**:25
447. Sugimae A (1980) *Anal Chim Acta* **121**:331
448. Statham PJ (1985) *Anal Chim Acta* **169**:149
449. International Council for Exploration of the Sea (1982) Marine environment quality committee report CM1983/E24. Charlottenlund, Denmark
450. Bender ML, Klinkhammer GP, Spencer DW (1977) *Deep-Sea Res* **24**:799
451. Klinkhammer GP, Bender ML (1980) *Earth Planet Sci Lett* **46**:361
452. Carnrick GR, Slavin W, Manning DC (1981) *Anal Chem* **53**:1866
453. Lan CR, Alfassi ZB (1994) *Analyst* **119**:1033
454. Knox S, Turner DR (1980) *Estuar Coast Mar Sci* **10**:317
455. Department of the Environment and the National Water Council, Standing Committee of Analysts (1978) Manganese in raw and potable waters by spectrophotometry (using formaldoxime), 1977. Methods for the examination of waters and associated materials. HMSO, London
456. Wiggins PT, Duffy D, El Kady AA (1972) *Anal Chim Acta* **61**:421
457. Hadeishi T, McLaughlin RD (1971) *Science* **174**:404
458. Hatch WR, Ott WL (1968) *Anal Chem* **40**:2085
459. Hinckle ME, Learned RE (1969) *US Geological Survey, Professional papers* **650-D**:251
460. Fishman MJ (1970) *Anal Chem* **42**:1462
461. Lindsteat G (1970) *Analyst* **95**:264
462. Chau YK, Saitoh H (1970) *Environ Sci Tech* **4**:839
463. Omang SH (1971) *Anal Chim Acta* **53**:415
464. Omang SH, Paus PE (1971) *Anal Chim Acta* **56**:393
465. Hwang JH, Ullucci PA, Malenfant AL (1971) *Canadian Spectroscopy* **16**:1
466. Aston SR, Riley JP (1972) *Anal Chim Acta* **59**:349
467. Muscat VI, Vickers TJ, Andren A (1972) *Anal Chem* **44**:218
468. Topping G, Pirie JM (1972) *Anal Chim Acta* **62**:200
469. Carr RA, Hoover JB, Wilkniss PE (1972) *Deep-Sea Res* **19**:747
470. Omang SH (1973) *Anal Chim Acta* **63**:247
471. Gardner D, Riley JP (1973) *Nature* **241**:526
472. Olafsson J (1974) *Anal Chim Acta* **68**:207
473. Muscat VI, Vickers TJ (1970) *Anal Chim Acta* **18**:2275
474. Leatherland TM, Burton JD, McCartney MJ, Culkin F (1971) *Nature* **232**:112
475. Chester R, Gardner D, Riley JP, Stoner J (1973) *Mar Pollut Bull* **28**:4
476. Fitzgerald WF, Hunt CD (1973) Abstract of the bulletin of the French oceanographic union, A-5
477. Fitzgerald WF, Lyons WB, Hunt CD (1974) *Anal Chem* **46**:1882
478. Olafsson J (1982) *Mar Chem* **11**:129
479. Filippelli M (1984) *Analyst* **109**:515
480. Blake S (1985) Method for the determination of low levels of mercury in fresh and saline waters. UE Technical Repor TR229. Water Research Centre, Medmenham
481. Gill GA, Fitzgerald WF (1987) *Mar Chem* **20**:277
482. Bloxam MG, Gachanja A, Hill SJ, Worsfold PJ (1996) *J Anal Atom Spectrosc* **11**:145

483. Turyan I, Mandler D (1993) *Nature* **362**:703
484. Debrak E, Denoyer ER, Tyson JF (1993) *J Anal Atom Spectrosc* **11**:127
485. Wrembel HZ (1983) *Talanta* **30**:481
486. Wrembel HZ, Pajak WA (1986) *Chem Anal (Warsaw)* **31**:409
487. Voyce D, Zeitlin H (1974) *Anal Chim Acta* **69**:27
488. Agemian H, Da Silvia JA (1979) *Anal Chim Acta* **104**:285
489. Davies IM, Pirie JM (1978) *Mar Pollut Bull* **9**:128
490. Topping G, Pirie JM, Graham WC, Shepher RJ (1975) An examination of the heavy metal levels in muscle, kidney, and liver of saithe in relation to year class, area of sampling, and season. *ICE5CM E*:37
491. Watling RJ (1975) *Anal Chim Acta* **75**:281
492. Nurnberg HW, Valenta P, Sipos L, Branica M (1980) *Anal Chim Acta* **115**:25
493. Hiyai Y, Murao Y (1972) *Analyst* **21**:608
494. Weiss HV, Crozier TE (1972) *Anal Chim Acta* **58**:231
495. Jaya S, Rao TP, Rao GP (1985) *Analyst* **110**:1361
496. Pelizzetti E (1997) *Water Science Technol Lab* **28**:1
497. Kawabuchi K, Kuroda R (1969) *Anal Chim Acta* **46**:23
498. Kuroda R, Tarui T (1974) *Fresen Z Anal Chem* **269**:22
499. Korkisch J, Godl L, Gross H (1975) *Talanta* **22**:669
500. Kiriya T, Kuroda R (1984) *Talanta* **31**:472
501. Nutaksuka I, Nishimura A, Ohzeki K (1995) *Anal Chim Acta* **304**:243
502. Van den Sloom HA, Wals GD, Das HA (1977) *Prog Water Technol* **8**:193
503. Muzzarelli RAA, Rochetti R (1973) *Anal Chim Acta* **64**:371
504. Emerick RJ (1987) *Atom Spectrosc* **8**:69
505. Kuroda R, Matsumoto N, Ogmura K (1988) *Fresen Z Anal Chem* **330**:111
506. Specht AA, Beauchemin D (1988) *Anal Chem* **70**:1036
507. Hua C, Jagner D, Renman L (1987) *Anal Chim Acta* **192**:103
508. Willie SN, Berman SS, Page JA, Van Loon (1987) *Canadian J Chem* **65**:957
509. Hidalgo JL, Gomez MA, Caballero M, Cela R, Perez-Bustamonte JA (1988) *Talanta* **35**:301
510. Van den Berg CMG (1985) *Anal Chem* **57**:1532
511. Kimura A, Yoneda A, Maeda Y, Azumi T (1985) *Nippon Kaisui Gakkaishi* **40**:141
512. Hanson G, Szalo A, Chasteen ND (1977) *Anal Chem* **49**:461
513. Mok WM, Wai CW (1984) *Anal Chem* **56**:27
514. Kulathilake AI, Chatt A (1980) *Anal Chem* **52**:828
515. Monien H, Bovenkerk R, Kringe KP, Rath D (1980) *Fresen Z Anal Chem* **300**:363
516. Shriadah MMA, Katoaka M, Ohzeki K (1985) *Analyst* **110**:125
517. Kim YS, Zeitlin H (1971) *Separ Sci* **6**:505
518. Boyle EA, Edmond JA (1977) *Anal Chim Acta* **91**:189
519. Bruland KW (1980) *Sci Lett* **47**:176
520. Boyle EA, Husted, SS, Jones SP (1981) *Journal of Geographical Research* **86**:8048
521. Kentner E, Armitage D, Zeitlin H (1970) *Anal Chim Acta* **45**:343
522. Yatsimirskii KB, Ewel'yakov EM, Pablova VK, Savichenko YaS (1973) *Okeanologiya* **11**:11, 10. Ref Zhur Khim **19**GD Abstract No HG203
523. Rampon H, Cavalier R (1972) *Anal Chim Acta* **60**:226
524. Lee DS (1982) *Anal Chem* **60**:226
525. Nishocka H, Assadamongkol S, Maeda Y, Azumi T (1987) *Nippon Kaisui Gakkaishi* **40**:286
526. Van den Berg CMG, Nimmo M (1987) *Sci Total Environ* **60**:185
527. Lo J, Cheng BJ, Tseng Cl, Lee JD (1993) *Anal Chim Acta* **281**:429

528. Koide M, Goldberg ED, Walker R (1996) *Deep-Sea Res Part II* **43**:53
529. Koide M, Goldberg ED, Walker R (1996) *Deep-Sea Res Part II* **43**:55
530. Wang Z, Li Y, Li Y, Guo Y (1994) *Anal Lett* **27**:957
531. Van den Berg CMG, Jacinto GS (1988) *Anal Chim Acta* **211**:129
532. Torbjoern A, Jaquer D (1973) *Anal Chim Acta* **66**:152
533. Torbjoern A, Jaquer D (1972) *Anal Abst* **23**:994
534. Marquis G, Lebel J (1981) *Anal Lett* **14**:913
535. Marezak M, Ziaga E (1973) *Chemica Acta* **18**:99
536. Ward GK (1979) Report No 9966. National Technical Information Service, Springfield, VA, USA
537. Koide H, Hodge V, Yang JS, Goldberg ED (1987) *Anal Chem* **59**:1802
538. Matthews AD, Riley JP (1970) *Anal Chim Acta* **51**:455
539. Schoenfeld I, Held S (1969) *Israel J Chem* **7**:831
540. Smith RC, Pillai KC, Chow TJ, Folsom TR (1965) *Limnol Oceanogr* **10**:226
541. Lebedev VA, Alvarez UV, Krasnyanskii AV, Shurnupova TI, Golubtsov IV (1987) *Vestn Mosk Univ Ser Khim* **28**:1744
542. Bryer P, Gilbert BP (1987) *Anal Chim Acta* **201**:33
543. Riley JP, Skirrow G (1975) *Chemical oceanography*, 2nd edn, vol 1. Academic Press, New York, p 418
544. Selenium (1976) Committee on medical and biologic effects of environmental pollutants. National Academy of Sciences, Washington, DC
545. Luckey TD, Venegopal B (1976) *Chem Eng News* **54**:2
546. Tzeng J-H, Zeitlin H (1978) *Anal Chim Acta* **101**:71
547. Neve J, Hanocq M, Molle L (1980) *Int J Environ Anal Chem* **8**:177
548. Cutter GA (1978) *Anal Chim Acta* **98**:59
549. Goldschmidt VM, Strock LW (1935) *Nachr Akad Wiss Goettingen Math-Physik KI, IV*, **NF 1**:123
550. Wattenberg H (1938) *Zeitung Anorganic Chemie* **236**:339
551. Ishibashi M, Shigematsu T, Nakagawa Y (1953) Recent oceanographic work in Japan. Special Number **1**:44
552. Chau YK, Riley JP (1965) *Anal Chim Acta* **33**:36
553. Schutz DF, Turekian KK (1963) Abstracts of papers XIII, Paper 23. General Assembly IUGG, Berkeley
554. Schutz DF (1964) PhD Thesis. Department of Geology, Yale University
555. Shimoishi Y (1973) *Anal Chim Acta* **64**:465
556. Measures CI, Burton JD (1980) *Anal Chim Acta* **120**:177
557. Bermejo-Barrera P, Moreda-Pineiro J, Moreda-Pineiro A, Bermejo-Barrera A (1996) *Talanta* **43**:35
558. Miller LA, Bruland KW (1995) *Environ Sci Tech* **29**:2616
559. Kawabuchi K, Riley JP (1973) *Anal Chim Acta* **65**:271
560. Kulev II, Stanev DS, Bakalov VD (1974) *Khimiya Indust* **46**:65
561. Kulev II, Bakalov VD (1973) *CR Bulgarian Acad Science* **26**:787
562. Carr RA (1970) *Limnol Oceanogr* **15**:318
563. Petit L (1985) *J Internationale d'Océanographie Medical* **19**:79
564. Andraea MV (1984) *Anal Chem* **56**:2064
565. Moran SB, Hoff JA, Buesseler KO, Edwards RL (1995) *Geophys Res Lett* **22**:2589
566. Guo L, Santschi PH, Daskaran M, Zindler A (1995) *Earth Planet Sci Lett* **133**:117
567. Kodama Y, Tsubota H (1971) *Japan Analyst* **20**:1554
568. Dogan S, Haerdi W (1980) *Int J Environ Anal Chem* **8**:249
569. Bergerioux C, Haerdi W (1980) *Analusis* **8**:169

570. Brinckmann FE (1981) Trace metals in seawater. In: Wong CS et al. (eds) Proceedings of a NATO advanced research institute on trace metals in seawater, Sicily, Italy. Plenum Press, New York, p 488
571. Aue WA, Flinn CS (1977) *J Chromatogr* **142**:145
572. Jackson JA, Blair WR, Brinckmann FE, Iverson WP (1982) *Environ Sci Tech* **16**:110
573. Jewett KL, Brinckmann FE (1981) *J Chromatogr Sci* **19**:583
574. Brinckmann FE, Blair WR, Jewett KL, Iverson WP (1977) *J Chromatogr Sci* **15**:493
575. Brinckmann FE (1981) *J Organomet Chem* **12**:343
576. Jewett KI, Brinckman FE, Bellama JM (1978) Influence of environmental parameters on transmethylation between aquated metal ions. In: Brinckmann FB, Bellama JM (eds) *Organometals and organometalloids: occurrence and fate in the environment*. American Chemical Society, Washington, DC, pp 158–187
577. Michael LC, Erickson MD, Parks SP, Pellizari BD (1980) *Anal Chem* **52**:1836
578. Braman RS, Tompkins MA (1979) *Anal Chem* **51**:12
579. Schaeffer GW, Emilius M (1954) *J Am Chem Soc* **76**:1203
580. Hodge VE, Seidel SL, Goldberg FD (1979) *Anal Chem* **51**:1256
581. Evans WH, Jackson FJ, Dellar D (1979) *Analyst* **104**:16
582. Hallas LE (1978) PhD Thesis. University of Maryland
583. Paris GE, Blair WE, Brinckmann FE (1977) *Anal Chem* **49**:378
584. Florence TM, Farrar YJ (1974) *Journal of Electro Anal Chem* **51**:191
585. Florence TM (1971) *Anal Abstr* **20**:4585
586. Florence TM (1972) *Anal Abstr* **25**:5011
587. Gandon R, Guegueniat P (1992) *Radiochim Acta* **57**:159
588. Yang CY, Shih JS, Yeh YC (1981) *Analyst* **106**:385
589. Huh CA, Bacon MP (1985) *Anal Chem* **57**:2065
590. Agrawal YK, Upadhyaya DB, Chudasma SP (1993) *J Radioanal Nucl Chem* **170**:79
591. Djogic R, Branica M (1995) *Analyst* **120**:1989
592. Economou A, Fielden PR, Packham A (1994) *Analyst* **119**:279
593. Van den Berg CMG, Nimmo M (1987) *Anal Chem* **59**:924
594. Spencer R (1968) *Talanta* **15**:1307
595. Hua C, Jagner D, Renman L (1987) *Anal Chim Acta* **197**:265
596. Nishimura M, Matsunaga K, Kudo T, Obara F (1973) *Anal Chim Acta* **65**:466
597. Kiriya T, Kuroda R (1972) *Anal Chim Acta* **62**:464
598. Monien H, Stangel R (1982) *Fresen Z Anal Chem* **311**:209
599. Hastings DW, Emerson SR, Nelson BK (1996) *Anal Chem* **68**:371
600. Van den Berg CMG, Huang O (1984) *Anal Chem* **56**:2383
601. Vega M, Van den Berg CMG (1994) *Anal Chim Acta* **293**:19
602. Weiss HV, Guttman HA, Korkisch J, Stefan I (1977) *Talanta* **24**:509
603. Korkisch J, Gross H (1973) *Talanta* **20**:1153
604. Bruland KW, Franks RP (1983) In: Wong CS et al. (eds) Proceedings of a NATO advanced research institute on trace metals in seawater, Sicily, Italy. Plenum Press, New York, pp 256–298
605. Bruland KW, Knauer GA, Martin JH (1978) *Nature* **271**:741
606. Danielsson LG, Westerlund S (1983) In: Wong CS et al. (eds) Proceedings of a NATO advanced research institute on trace metals in seawater, Sicily, Italy. Plenum Press, New York, pp 85–95
607. Magnusson B, Westerlund S (1985) In: Wong CS et al. (eds) Proceedings of a NATO advanced research institute on trace metals in seawater, Sicily, Italy. Plenum Press, New York, pp 467–473
608. Donat JR, Bruland KW (1990) *Mar Chem* **28**:301

609. Nowicki JL, Johnson KS, Coale KH, Eirod VA, Lieberman SH (1994) *Anal Chem* **66**:2732
610. Burrell DC, Wood GG (1969) *Anal Chim Acta* **48**:45
611. Guevremont R (1981) *Anal Chem* **53**:911
612. Mykytink AP, Russell DS, Sturgeon RE (1980) *Anal Chem* **52**:123
613. Andraea MO, Asmode JF, Foster P, Van't Dack L (1981) *Anal Chem* **53**:1706
614. Andraea MO (1977) *Anal Chem* **49**:820
615. Foreback CC (1973) Some studies on the detection and determination of mercury, arsenic, and antimony in gas discharges. Thesis. University of South Florida
616. Huang SD, Shih KY (1995) *Spectrochim Acta B* **50**:837
617. Akatsuka K, Katoh T, Nobuyama N, Okanaka T, Okumura M, Hoshi S (1996) *Anal Sci* **12**:109
618. Hirata S, Honda K (1987) *Bunseki Kagaku* **36**:213
619. Van den Berg CMG (1985) *Mar Chem* **16**:121
620. Van den Berg CMG (1984) *Talanta* **31**:1069
621. Zima J, Van den Berg CMG (1994) *Anal Chim Acta* **289**:291
622. Muzzarelli RAA, Sipos LG (1971) *Talanta* **18**:853
623. Lieberman SH, Zirino H (1974) *Anal Chem* **46**:20
624. Johnson KS, Coale KH, Jannasch HW (1992) *Anal Chem* **64**:1070
625. Kim YS, Zeitlin H (1973) *Separ Sci* **7**:1
626. Shigematsu T, Nishikawa Y, Hiraki K, Goda S, Tsujumatu (1971) *Japan Analyst* **20**:575
627. Lee C, Kim NB, Lee IC, Chung KS (1977) *Talanta* **24**:241
628. Lieser KH, Calmano W, Heuss E, Neitzert V (1977) *J Radioanal Chem* **37**:717
629. Elderfield H, Greaves HJ (1981) Trace metals in seawater. In: Wong CS et al. (eds) *Proceedings of a NATO advanced research institute on trace metals in seawater, Sicily, Italy*. Plenum Press, New York, p 427
630. Hooker PJ (1974) BA Thesis. University of Oxford
631. Hooker PJ, O'Nions RK, Pankhurst RJ (1975) *Chem Geol* **16**:189
632. Korkisch J, Arrhenius G (1964) *Anal Chem* **36**:850
633. Faris JP, Warton JW (1962) *Anal Chem* **34**:1077
634. Desai HB, Krishnamoorthy IR, Sandar Das M (1964) *Talanta* **11**:1249
635. Brunfelt AO, Steinnes E (1969) *Analyst* **94**:979
636. Möller P, Dulski P, Luck J (1992) *Spectrochim Acta B* **47**:1379
637. Elderfield H, Greaves MJ (1982) *Nature* **296**:214
638. Doherty W (1989) *Spectrochim Acta B* **44**:263
639. Stroh A (1992) *Atom Spectrosc* **13**:89
640. Evans EH, Giglio JJ (1993) *J Anal Atom Spectrosc* **8**:1
641. Daidoji H, Tamura S, Matsubara M (1985) *Bunseki Kagaku* **34**:340
642. Greaves MJ, Elderfield H, Klinkhammer GP (1989) *Anal Chim Acta* **218**:265
643. Piepgras DJ, Jacobsen SB (1992) *Geochim Cosmochim Acta* **56**:1851
644. LeBaar HJW, Bacon MP, Brewer PG (1985) *Geochim Cosmochim Acta* **49**:1943
645. LeBaar HJW, Brewer PG, Bacon MP (1985) *Geochim Cosmochim Acta* **49**:1961
646. Sawatari H, Toda T, Saizuka T, Kimata C, Itoh A, Haraguchi H (1995) *Bull Chem Soc Japan* **68**:3065
647. Esser BK, Volpe A, Kenneally JM, Smith DK (1994) *Anal Chem* **66**:1736
648. Halicz L, Gavrieli I, Dorfman E (1996) *J Anal Atom Spectrosc* **11**:811
649. Shabani MB, Akagi T, Shimizu H, Masuda A (1990) *Anal Chem* **62**:2709
650. Shabani MB, Akagi T, Shimizu H, Masuda A (1992) *Anal Chem* **64**:737
651. Murty DSR, Chakrapani G (1996) *J Anal Atomic Spectrosc* **11**:815
652. Zhang T-H, Shan X-Q, Liu R-X, Tang H-X, Zhang S-Z (1998) *Anal Chem* **70**:3964
653. Mascini M (1971) *Anal Chim Acta* **56**:316

654. Jagner D, Kerstein A (1971) *Anal Chim Acta* **57**:185
655. Jagner D, Kerstein A (1972) *Anal Abstr* **23**:1190
656. Pausch JB, Margerum DV (1969) *Anal Chem* **41**:226
657. Atienza J, Henrero MA, Maquiera A, Duchades R (1992) *Crit Rev Anal Chem* **64**:231
658. Tao H, Miyazaki A, Bansho K, Umezaki Y (1984) *Anal Chem* **56**:181
659. Armannsson H (1979) *Anal Chim Acta* **110**:21
660. Olsen S, Luiz CR, Pessenda JR, Hansen EO (1983) *Analyst* **108**:905
661. Fang Z, Ruzicka J, Hansen EH (1984) *Anal Chim Acta* **164**:23
662. Cabezon LM, Caballero M, Cela R, Perez-Bustamante JA (1984) *Talanta* **31**:597
663. Orren MJ (1971) *Journal of South African Chemical Institute* (1971) **24**:96
664. Zhuang Z, Yang C, Wang X, Huang B (1996) *Fresen J Anal Chem* **355**:277
665. Chakraborti D, Adams F, Van Mol W, Irgolic KJ (1987) *Anal Chim Acta* **196**:23
666. Jin L, Wui D, Ni Z (1987) *Huaxue Xuebao* **45**:808
667. Rodienova TV, Ivanov VM (1986) *Zh Anal Khim* **41**:2181
668. Allain P, Mauras Y (1984) *Anal Chim Acta* **165**:141
669. Doidge PS (1985) *Spectrochim Acta* **40B**:569
670. Manning DC, Slavin W, Myers S (1979) *Anal Chem* **51**:2375
671. Bengtsson M, Danielsson LG, Magnusson B (1979) *Anal Lett* **12**:A13
672. Campbell WC, Ottaway JH (1977) *Analyst* **102**:495
673. Stein VB, Canelli G, Richards AH (1980) *Int J Environ Anal Chem* **8**:99
674. Cachetti G, Cvelic-Lazzari N, Rolle E (1981) *Metodi Analitica per le Aeqe* **2**:1
675. Montgomery JR, Peterson GN (1980) *Anal Chim Acta* **117**:397
676. Lyons MB, Fitzgerald WF (1981) Trace metals in seawater. In: Wong CS et al. (eds) *Proceedings of a NATO advanced research institute on trace metals in seawater, Sicily, Italy*. Plenum Press, New York, p 625
677. Brooks RR, Presley BJ, Kaplan IR (1967) *Talanta* **14**:809
678. Yates J (1982) Technical report TR181. Determination of trace metals (cadmium, copper, lead, nickel, and zinc) in filtered saline water samples. Water Research Centre, Medmenham, UK
679. Boyle EA, Edmond JM (1977) *Anal Chim Acta* **91**:1801
680. Brugmann L, Danielsson LG, Magnusson B, Westerlund S (1983) *Mar Chem* **13**:327
681. Hoenig M, Wollast R (1982) *Spectrochim Acta B* **37B**:399
682. Tominaga M, Bansho K, Umezaki Y (1985) *Anal Chim Acta* **169**:171
683. Tominaga M, Bansho K, Umezaki Y (1985) *Anal Chim Acta* **169**:176
684. Hayase K, Shitashima K, Tsubota H (1986) *Talanta* **33**:754
685. Tikhoirova AA, Patini SA, Morozov NP (1976) *Zh Anal Khim* **31**:282
686. The Analytical Report, No. 12 (1988) Perkin-Elmer Ltd., Beaconsfield, UK, p 6
687. Slavin W, Carnrick GR, Manning DC (1982) *Anal Chem* **54**:621
688. *Techniques in Graphite Furnace Atomic Absorption Spectrometry* (1982) Perkin-Elmer Ltd., Beaconsfield, UK, Part No. 0993-8150
689. Hodge V, Stallard M, Koide M, Goldberg ED (1986) *Anal Chem* **58**:616
690. Abollino O, Aceto M, Sacchero G, Sarzanini C, Mentasti E (1995) *Anal Chim Acta* **305**:200
691. Cimadevilla EA-C, Wrobel K, Sanz-Medel A (1995) *J Anal Atom Spectrosc* **10**:149
692. Hadeishi T, Church DA, McLaughlin RD, Zak BD, Nakamura M, Chang B (1975) *Science* **187**:348
693. Koizumi H, Yasuda K (1975) *Anal Chem* **47**:1679
694. Stephens R, Ryan DE (1975) *Talanta* **22**:655
695. Stephens R, Ryan DE (1975) *Talanta* **22**:659
696. Veinot DE, Stephens R (1976) *Talanta* **23**:849

697. Koizumi H, Yasuda K (1976) *Spectrochim Acta* **31B**:237
698. Koizumi H, Yasuda K (1976) *Anal Chem* **48**:1178
699. Stephens R, Ryan DE (1978) *Talanta* **25**:435
700. Stephens R (1979) *Talanta* **26**:57
701. Lawson JB, Grassam E, Ellis DJ, Keir MJ (1976) *Analyst* **101**:315
702. Grassam E, Dawson JB, Ellis DJ (1977) *Analyst* **102**:804
703. Koizumi H, Yasuda K (1976) *Spectrochim Acta B* **31B**:523
704. Koizumi H, Yasuda K, Katayama M (1977) *Anal Chem* **49**:1106
705. Parnandez FJ, Bohler W, Beatty NM, Barnett WB (1981) *Atom Spectrosc* **2**:73
706. Slavin W, Manning DC, Carnrick GR (1981) *Atom Spectros* **2**:137
707. Grabenski Z, Lehmann R, Radzuik B, Voellkopf U (1984) *Atom Spectros* **5**:87
708. De Kersabiec AM, Blanc G, Pinta M (1985) *Fresen Z Anal Chem* **322**:731
709. Grobanski Z, Lehmann R, Radzuck B, Voellkopf U (1984) The determination of trace metals in seawater using Zeeman graphite furnace AAS. In: *Atomic Spectroscopy Application Study No. 686* (1984) Papers presented at Pittsburgh Conference, Atlantic City, NJ, USA
710. *Analytical Methods for Graphite Furnace AAS* (1984) Perkin-Elmer
711. Cabon JY, Le Bihan A (1995) *Spectrochim Acta B* **50B**:1703
712. Andrae MOP (1981) Trace metals in seawater. In: Wong CS et al. (eds) *Proceedings of a NATO advanced research institute on trace metals in seawater, Sicily, Italy*. Plenum Press, New York
713. Braman RS, Justen LC, Foreback CC (1972) *Anal Chem* **44**:2195
714. Braman RS, Foreback CC (1973) *Science* **182**:1247
715. Tompkins MA (1977) *Environmental-analytical studies of antimony, germanium, and tin*. Thesis. University of South Florida
716. Andrae MO, Froelich PN (1981) *Anal Chem* **53**:287
717. Fleming HH, Ide RG (1976) *Anal Chim Acta* **75**:8367
718. Crecelius EA (1978) *Anal Chem* **50**:826
719. Nakashima S, Sturgeon RE, Willie SN, Berman SR (1988) *Anal Chim Acta* **207**:291
720. Foreback CC (1973) Some studies on the detection and determination of mercury, arsenic, and antimony in gas discharges. Thesis. University of South Florida
721. Margoshes M, Scribner BF (1959) *Spectrochim Acta* **15**:138
722. Korolev VV, Vainshtein EE (1959) *Z Anal Chem* **15**:658
723. Owen LW (1961) *Appl Spectros* **15**:150
724. Valente SE, Schrenk WG (1970) *Appl Spectros* **24**:197
725. Marinkovic M, Vickers EJ (1971) *Appl Spectros* **25**:319
726. Chapman JE, Dale LS, Whittem RN (1973) *Analyst* **98**:529
727. Merchant P, Veillon C (1974) *Anal Chim Acta* **70**:17
728. Murdick DA Jr, Piepmeier EH (1974) *Anal Chem* **46**:678
729. Rippetoe WE, Johnson ER, Vickers TI (1975) *Anal Chem* **47**:436
730. Winge RK, Fassel VA, Kniseley RN, DeKalb E, Raas WJ (1977) *Spectrochim Acta* **32B**:327
731. Nygaard DD (1979) *Anal Chem* **51**:881
732. McLeod CW, Otsuki K, Okamoto H, Fuwa K, Haraguchi H (1981) *Analyst* **106**:419
733. Mujazaki A, Kimura A, Bansho K, Amezaki Y (1981) *Anal Chim Acta* **144**:213
734. Blockaert JAC, Leis F, Laguna K (1981) *Talanta* **28**:745
735. Berman SS, McLaren JW, Willie SN (1980) *Anal Chem* **52**:488
736. Sturgeon RE, Berman SS, Desaulniers JAH, Mykytiuk AP, McLaren JW, Russell DS (1980) *Anal Chem* **52**:1585
737. Hiraide M, Ito T, Baba M, Kawaguchi H, Mizuike A (1980) *Anal Chem* **52**:804

738. McLaren JW, Mykytiuk AP, Willie SN, Berman SS (1985) *Anal Chem* **57**:2907
739. De Oliveira, McLaren E, Berman SS (1983) *Anal Chem* **55**:2047
740. Berndt H, Harms U, Sonneborn M (1985) *Fresen Z Anal Chem* **322**:329
741. Beauchemin M, Berman SS (1989) *Anal Chem* **61**:1857
742. Chong NS, Norton ML, Anderson JL (1990) *Anal Chem* **62**:1043
743. Chapple G, Byrne JP (1996) *J Anal Atom Spectrosc* **11**:549
744. Alves LC, Allen LA, Houk RS (1993) *Anal Chem* **65**:2468
745. Vandecasteele C, Nagels M, Vanhoe NH, Dams R (1988) *Anal Chim Acta* **211**:91
746. Stroh A, Voellkopf U (1993) *J Anal Atom Spectrosc* **8**:35
747. Field MP, Cullen JT, Sherrell RM (1999) *J Anal Atom Spectrosc* **14**:1425
748. Taylor DB, Kingston HM, Nogay DJ, Koller D, Hutton R (1996) *J Anal Atom Spectrosc* **11**:187
749. Seubert A, Petzold G, McLaren JW (1995) *J Anal Atom Spectrosc* **10**:371
750. Bettinelli M, Spezia S (1995) *J Chromatogr A* **709**:275
751. Bloxam MJ, Hill SJ, Worsfold FJ (1993) *Anal Proc* **30**:159
752. Nygaard DD, Hill SR (1979) *Anal Lett* **12**:491
753. Whitnack GC, Basselli R (1969) *Anal Chim Acta* **47**:267
754. Komatsu M, Matsueda T, Kakiyami H (1971) *Japan Analyst* **20**:987
755. David J, Redmond JD (1971) *Journal of Electro Anal Chem* **33**:169
756. Florence TM (1972) *Journal of Electro Anal Chem* **35**:237
757. Rojohn T (1972) *Anal Chim Acta* **62**:438
758. Seitz WR, Jones R, Klatt LN, Mason WD (1973) *Anal Chem* **45**:810
759. Clem RG, Litton G, Ornelas LD (1973) *Anal Chem* **45**:1306
760. Clem RG (1973) *MPJ Application Notes* **8**:1
761. Bubic S, Sipos L, Branica M (1973) *Thalass Jugoslavia* **9**:55
762. Chau YK, Gachter R, Lum-Shue-Chan K (1974) *Journal of the Fisheries Research Board, Canada* **31**:1515
763. Nurnberg HW, Valenta P, Mart L, Raspor B, Sipos L (1976) *Fresen Z Anal Chem* **282**:357
764. Florence TM, Batley GE (1977) *Talanta* **24**:151
765. Whitnack GC, Sanelli R (1969) *Anal Chim Acta* **47**:269
766. Smith JD, Redmond JD (1971) *Journal of Electro Anal Chem* **33**:169
767. Sinko I, Dolczal J (1970) *Journal of Electro Anal Chem* **25**:299
768. Cambon JP, Cauw G, Monaco A (1977) *Review of International Oceanographic Medicine T. XIVIII*, 2:73
769. Welghe N, Claeys A (1972) *Journal of Electro Anal Chem* **35**:229
770. Brugmann L (1974) *Acta Hydrochim Hydrobiol* **2**:123
771. Lund W, Salberg M (1975) *Anal Chim Acta* **76**:131
772. Gardner J, Stiff MJ (1975) *Water Res* **9**:517
773. Abdullah MI, Reusch Berg B, Klimek R (1976) *Anal Chim Acta* **84**:307
774. Duyckaerts G, Gillain G (1977) *Essays in memory of Anders Ringbom*. Pergamon Press, Oxford
775. Brezonik PL (1974) In: Rubin AJ (ed) *Aqueous environmental chemistry of metals*. Ann Arbor Science Publishers, Ann Arbor, Michigan, p 167
776. Elder JF (1975) *Limnol Oceanogr* **20**:96
777. O'Shea TA, Maney KH (1976) *Anal Chem* **48**:1603
778. Batley GE, Matousek JP (1980) *Anal Chem* **52**:1570
779. Young J, Gurtisen JM, Apts CW, Crecelius EA (1979) *Mar Environ Res* **2**:265
780. Batley GE (1981) *Anal Chim Acta* **124**:121
781. Scarponi G, Capodaglio G, Cescon P, Cosma B, Frache R (1982) *Anal Chim Acta* **135**:263
782. Brügman L, Danielsson LG, Magnusson B, Westerlund S (1983) *Mar Chem* **13**:329

783. Clem RG, Hodgson AT (1978) *Anal Chem* **50**:102
784. Brüggman L (1984) *Sci Total Environ* **37**:41
785. Bruland KW, Coale KH, Mart L (1985) *Mar Chem* **17**:285
786. Achterberg EP, Van den Berg CMG (1996) *Mar Pollut Bull* **32**:471
787. Brihaye C, Gillain G, Duyckaerts G (1983) *Anal Chim Acta* **148**:51
788. Cuculic V, Branica M (1996) *Analyst* **121**:1127
789. Sipos L, Golimoivski J, Valenta P, Nurnberg HW (1979) *Fresen Z Anal Chem* **298**:1
790. Bott A (1995) *Current Separation* **14**:24
791. Bond AM, Heritage ID, Thormann W (1986) *Anal Chem* **58**:1063
792. Nurnberg HW (1984) *Sci Total Environ* **37**:9
793. Mart L, Nurnberg WH, Dryssen D (1981) Trace metals in seawater. In: Wong CS et al. (eds) *Proceedings of a NATO advanced research institute on trace metals in seawater, Sicily, Italy*. Plenum Press, New York
794. Valenta P, Mart L, Rutzel H (1977) *Journal of Electro Anal Chem* **82**:327
795. Pihlar B, Valenta P, Nurnberg HW (1981) *Fresen Z Anal Chem* **307**:337
796. Pietrowicz SR, Springer-Young M, Puig JA, Spencer MJ (1982) *Anal Chem* **54**:1367
797. Lund W, Onshus D (1976) *Anal Chim Acta* **86**:109
798. Van den Berg CMG (1984) *Geochim Cosmochim Acta* **48**:2613
799. Kraznaric D (1984) *Mar Chem* **15**:117
800. Andruzzi R, Trazza A, Marrosu G (1982) *Talanta* **29**:751
801. Andruzzi R, Trazza A, Marrosu G (1982) *Anal Lett (London)* **15**:1965
802. Jagner D, Josefson M, Westerlund S (1981) *Anal Chim Acta* **129**:153
803. Drabek I, Pfeiffer O, Madsen P, Sorensen J (1987) *Int J Environ Anal Chem* **15**:153
804. Donat JR, Bruland KW (1993) *Anal Chim Acta* **254**:547
805. Perez-Pina J, Hernandez-Brito JJ, Herrera-Melian JA, Collado-Sanchez C, Van den Berg CMG (1994) *Electroanalysis (NY)* **6**:1069
806. Van den Berg CMG (1994) *J Anal Atom Spectrosc* **6**:1069
807. Van den Berg CMG (1986) *Sci Total Environ* **49**:89
808. Eskilsson H, Haroldsson C, Jagner D (1985) *Anal Chim Acta* **175**:79
809. Prange A, Knochel A, Michaelis W (1985) *Anal Chim Acta* **172**:79
810. Prange A, Knoth J, Stossel R-P, Bodekker H, Kramer (1987) *Anal Chim Acta* **195**:275
811. Haarich M, Schmidt D, Freimann P, Jacobsen A (1993) *Spectrochim Acta B* **48**:183
812. Knochel A, Prange A (1981) *Fresen Z Anal Chem* **306**:252
813. Prange A, Omatsu M, Muskimoto S (1984) *X-Ray Spectrometry* **13**:83
814. Morris AW (1968) *Anal Chim Acta* **42**:397
815. Robertson DE, Carpenter R (1972) Report No. BNWL-SA-4455 Access 22569. National Technical Information Service, Springfield, VA, USA
816. Robertson DR, Carpenter R (1974) Report No. NAS-NS-3114 Access 26418. National Technical Information Service, Springfield, VA, USA
817. Piper DZ, Goles GG (1969) *Anal Chim Acta* **47**:560
818. Ghoda S (1972) *Bull Chem Soc Japan* **45**:1704
819. Brine E (1972) Report Aktiebolaget Atomenergi AE-466
820. Lo JM, Wei JC, Yeh SJ (1977) *Anal Chem* **49**:1146
821. Greenberg RR, Kingston HM (1982) *J Radioanal Chem* **71**:147
822. Greenberg RR, Kingston HM (1983) *Anal Chem* **55**:1160
823. Murthy RSS, Ryan DE (1983) *Anal Chem* **55**:682
824. Stiller M, Mantel M, Rappaport MS (1984) *J Radioanal Nucl Chem* **83**:345
825. Holzbecker J, Ryan DE (1982) *J Radioanal Chem* **74**:25
826. Chow TJ, Goldberg ED (1981) *Journal of Mar Res* **20**:163
827. Chow TJ, Patterson CC (1966) *Earth Planet Sci Lett* **1**:397

828. Wilson JD, Webster RK, Milner GWC, Barnett GA, Smales AA (1960) *Anal Chim Acta* **23**:505
829. Leipziger FD (1965) *Anal Chem* **37**:171
830. Paulsen P, Alvarez R, Kelleher D (1969) *Spectrochim Acta B* **24**:535
831. Chow TJ (1968) *Journal of the Water Pollution Control Federation* **399**
832. Patterson CC, Settle DM, Glover B (1976) *Mar Chem* **4**:305
833. Schalue B, Patterson CC (1980) The Occurrence of lead in the northeastern pacific, and the effects of anthropogenic inputs. In: Brancia M, Konrad Z (eds) *Lead in the marine environment*. Pergamon Press, Oxford, pp 31–43
834. Stukas VJ, Wong CS (1981) *Science* **211**:1424
835. Murozumi M (1981) Isotope dilution mass spectrometry of copper, cadmium, thallium, and lead in marine environments. Presented at The American Chemical Society Congress, Hawaii
836. Stukas VJ, Wong CS (1981) Trace metals in seawater. In: Wong CS et al. (eds) *Proceedings of a NATO advanced research institute on trace metals in seawater, Sicily, Italy*. Plenum Press, New York, p 513
837. Wu J, Boyle EA (1997) *Anal Chem* **69**:2464
838. Riel G (1995) In: King SE (ed) *Proceedings of the workshop on monitoring nuclear contamination in arctic seas*. Naval Research Laboratory, Washington, DC
839. Nagaosa Y, Kawabe H, Bond AM (1991) *Anal Chem* **63**:28
840. Shijo Y, Sato H, Uehara N, Aratake S (1996) *Analyst* **121**:325
841. Riccardo AA, Muzzarelli RAA, Raith G, Tubertini O (1970) *J Chromatogr* **47**:414
842. Bloxham MJ, Hill SJ, Worsfold FJ (1993) *Anal Proc* **30**:160
843. Morel FMM, Westall JC, O'Melia CR, Morgan JJ (1975) *Environ Sci Tech* **9**:756
844. Galloway JN (1979) *Geochim Cosmochim Acta* **43**:207
845. Long DT, Angino EE (1977) *Geochim Cosmochim Acta* **4**:1183
846. Dyrssen D, Wedborg M (1980) Major and minor elements, chemical speciation in estuarine waters. In: Olausson E, Cato I (eds) *Chemistry and biogeochemistry of estuaries*. Wiley, New York, pp 71–119
847. Amdurer M (1981) Trace metals in seawater. In: Wong CS et al. (eds) *Proceedings of a NATO advanced research institute on trace metals in seawater, Sicily, Italy*. Plenum Press, New York, p 537
848. Fukai R, Huynh-Ngoc L (1975) *Journal of Oceanographic Society of Japan* **31**:1
849. Young DR, Jan T-K, Hershelman GP (1980) Cycling of zinc in the nearshore marine environment. In: Nriagu JO (ed) *Zinc in the environment*. Wiley, New York, pp 298–335
850. Jennings CD (1978) *Mar Sci Comm* **4**:49
851. Cranston RE, Murray JW (1980) *Limnol Oceanog* **25**:1106
852. Van den Berg CMG (1983) *Anal Proc* **20**:455
853. Midorikawa M, Tanoue E, Sugimura Y (1990) *Anal Chem* **62**:1737
854. Mackey DJ (1982) *Mar Chem* **11**:169
855. Latouche C, Dumon LC, Lavaux G, Pedemaj P (1993) *Int J Environ Anal Chem* **51**:177
856. Baskaran M, Murphy DJ, Santschi PH, Orr JC, Schink DR (1993) *Deep-Sea Res* **40**:849
857. Magni EG, Tiziana G, Frache R (1995) *Anal Proc including Anal Comm* **32**:267
858. Zhang H, Davison W, Grime GW (1995) *ASTM Special Technical Publication STP 1293*, p 17
859. Resing JA, Measures CI (1994) *Anal Chem* **66**:4105
860. Sturgeon RE, Willie SN, Berman SS (1985) *Anal Chem* **57**:6
861. Pierce FD, Brown HR (1977) *Anal Chem* **49**:1417
862. Yusof AM, Ikhson ZB, Wood AKH (1994) *J Radioanal Nucl Chem* **179**:277
863. Sperling KR (1982) *Fresen Z Anal Chem* **310**:254

864. Ganzerli VMT, Stella R, Maggi L, Cicerci G (1987) *J Radioanal Nucl Chem* **114**:105
865. Janzer VJ (1973) *Journal of Research of US Geological Society* **1**:113
866. Zhang HT, Holzenbecker J, Ryan D (1983) *Anal Chim Acta* **149**:385
867. Henman KG (1980) *Toxicol Environ Chem Rev* **3**:111
868. Marshall MA, Mottola HA (1985) *Anal Chem* **57**:729
869. Kiriyaama T (1993) *Bunseki Kagaku* **42**:223
870. Kagoya S, Ueda J (1994) *Bull Chem Soc Japan* **67**:1965
871. Reimer RA, Miyazaki A (1992) *J Anal Atom Spectrosc* **7**:1239
872. Miyazaki A, Reimer RA (1993) *J Anal Atom Spectrosc* **8**:449
873. Liu ZS, Huang SD (1995) *Spectrochim Acta B* **50**:197
874. Flynn WW (1973) *Anal Chim Acta* **67**:129
875. Billah M, Honjo T, Terada K (1993) *Anal Sci* **9**:251
876. Olafsson J (1981) Trace metals in seawater. In: Wong CS et al. (eds) *Proceedings of a NATO advanced research institute on trace metals in seawater, Sicily, Italy*. Plenum Press, New York, p 476
877. Kwokal Z, May K, Branica M (1994) *Sci Total Environ* **154**:63
878. Fujita M, Iwashima K (1981) *Environ Sci Tech* **15**:929
879. Lo JM, Yu JC, Hutchison F, Wai CM (1982) *Anal Chem* **54**:2536
880. Fernandez-Garcia M, Pereiro-Garcia R, Bordel-Garcia N, Sanz-Medel A (1994) *Talanta* **41**:183
881. Chan KM, Riley JP (1966) *Anal Chim Acta* **36**:220
882. Ohta N, Fujita M, Tomura K (1979) *Bunseki Kagaku* **28**:277
883. Prabhu VG, Zarakar LR, Das MS (1980) *Microchim Acta* **11**:67
884. Kim YS, Zeitlin H (1969) *Anal Chim Acta* **46**:1
885. Head P, Burton JD (1970) *J Mar Biol Ass UK* **50**:439
886. Butler LRP, Matthews PM (1966) *Anal Chim Acta* **36**:319
887. Chau YK, Lum Shue Chan K (1969) *Anal Chim Acta* **48**:205
888. Akama Y, Nakai T, Kawamura F (1979) *Nippon Kaisui Gakkai-shi* **33**:180
889. Muzzarelli RAA (1971) *Anal Chim Acta* **54**:133
890. Vanderborgh BM, Van Grieken RE (1977) *Anal Chem* **49**:311
891. Yoshimura K, Hiraoka S, Tarutani T (1982) *Anal Chim Acta* **142**:101
892. Riley JP, Taylor D (1968) *Anal Chem* **41**:175
893. Ficklin WH (1982) *Anal Lett* **15**:865
894. Riley JP, Taylor D (1968) *Anal Chim Acta* **40**:479
895. Van der Sloot HA, Wals GD, Das HA (1977) *Anal Chim Acta* **90**:193
896. Hkagi T, Noriji Y, Matsui M, Haraguchi H (1985) *Appl Spectrosc* **39**:662
897. Zlatkis A, Bruening W, Bayer E (1971) *Anal Chim Acta* **56**:399
898. Bruland KW (1980) *Science Letters* **47**:177
899. Rampon H, Cuvelier R (1972) *Anal Chim Acta* **60**:226
900. Lee DS (1982) *Anal Chem* **54**:1182
901. Cowen JP, Hodge VF, Folsom TR (1977) *Anal Chem* **49**:494
902. Reid DF, Key RM, Schink DR (1979) *Earth Planet Sci* **43**:223
903. Chen Q, Aarkrog A, Nielson SP (1993) *J Radioanal Nucl Chem* **172**:281
904. Bomber AM, Equillor HE, Oliveira AA (1994) *J Radioanal Nucl Chem* **177**:27
905. Hirose K, Sugimura YJ (1985) *J Radioanal Nucl Chem* **92**:363
906. Sturgeon RE, Willie SN, Berman SS (1986) *Anal Chem* **58**:1140
907. Siu KWH, Berman SS (1984) *Anal Chem* **56**:1806
908. Avila AK, Curtius AJ (1994) *J Anal Atom Spectrosc* **9**:543
909. Honjo T, Nakata T (1987) *Bull Chem Soc Japan* **60**:2271
910. Chen Q, Dahlggaard H, Nielson SP (1994) *Anal Chim Acta* **285**:177

911. Momoshima N, Sayad M, Takashima Y (1993) *Radioanalytica Acta* **63**:73
912. Tao H, Rajendran RB, Quetel CR, Tominaga M, Nakazato T, Miyazaki A (1999) *Anal Chem* **71**:4208
913. Korkisch J, Koch W (1973) *Microchim Acta* **1**:157
914. Korkisch J (1972) *Microchim Acta* **6**:87
915. Kuroda R, Oguma K, Mukai N, Iwamoto M (1987) *Talanta* **34**:433
916. Wu TL, Lambert L, Hastings D, Banning D (1980) *Bull Environ Contam Toxicol* **24**:411
917. Hashimoto T (1971) *Anal Chim Acta* **56**:347
918. Kim YS, Zeitlin H (1971) *Anal Chem* **43**:1390
919. Nishimura M, Matsunaga K, Kudo T, Obara F (1973) *Anal Chim Acta* **65**:446
920. Dupont V, Auger Y, Jeandel C, Wartel M (1991) *Anal Chem* **63**:520
921. Nowicki JL, Private Communication
922. Sastry VN, Frishnamoorthy TM, Sarma TP (1968) *Current Science (Bombay)* **38**:279
923. Tsalev DL, Alimarin TP, Neiman SI (1972) *Zh Anal Khim* **27**:1223
924. El-Enamy FF, Mahmond KF, Varma MM (1979) *Journal of the Water Pollution Control Federation* **51**:2545
925. Pellenberg RE, Church TM (1978) *Anal Chim Acta* **97**:81
926. Jan TK, Young DR (1978) *Anal Chem* **50**:1250
927. Danielsson LG, Magnusson B, Westerlund S (1982) *Anal Chim Acta* **144**:183
928. Van Geen A, Boyle E (1990) *Anal Chem* **62**:1705
929. Bafti F, Cardinale AM, Bruzzone R (1992) *Anal Chim Acta* **270**:79
930. Ogura H, Oguma K (1994) *Microchem J* **49**:220
931. Yang Y, Huang W, Liu D (1987) *Xiamen Daxue Xuebao Ziran Kexueban* **26**:96
932. Dai SE, Chen TC, Wong GTF (1990) *Anal Chem* **62**:774
933. Buchanan AS, Hannaker P (1984) *Anal Chem* **56**:1379
934. Pai S-C, Chen T-C, Wong GTF, Hung CC (1990) *Anal Chem* **62**:774
935. Nakashima S, Sturgeon RE, Willie SN, Berman SS (1988) *Fresen J Anal Chem* **330**:592
936. Volkan M, Ataman OY, Howard AG (1987) *Analyst* **112**:1409
937. Terada K, Morimoto K, Kiba T (1980) *Anal Chim Acta* **116**:127
938. Lau CR, Yang M (1994) *Anal Chim Acta* **287**:111
939. Kawamura S, Sadao S, Katsumi K (1971) *Anal Chim Acta* **56**:405
940. Johansson M, Emteborg H, Glad B, Reinholdsson F, Baxter DC (1995) *Fresen J Anal Chem* **351**:461
941. Blain S, Appriou P, Handel H (1993) *Anal Chim Acta* **272**:91
942. Orians KJ, Boyle EA (1993) *Anal Chim Acta* **282**:63
943. Hirayama K, Unchara NN (1987) *Daigaku Kogakubu Kiyo Bunrui K* **28**:149
944. Rao RR, Chat A (1993) *J Radioanal Nucl Chem* **168**:439
945. Civici N (1994) *J Radioanal Nucl Chem* **186**:303
946. Zeng H-H, Thompson RB, Maliwal BP, Fores GR, Moffett JW, Flecke CA (2002) *Anal Chem* **74**:6807
947. Nakazato T, Tao H, Toniguchi T, Isshiki K (2002) *Talanta* **58**:121
948. Izumi Y, Kiyotaki F, Minato T, Seida Y (2002) *Anal Chem* **74**:3819
949. Baena JR, Gallego M, Vacarcel M (2002) *Anal Chem* **74**:1519
950. Wen B, Shan X, Xu SG (1999) *Analyst* **124**:621
951. Tony KA, Kartikeyan S, Vijayalakshmy B, Rao Tp, Iyer CSP (1999) *Analyst* **124**:191
952. Chang HJ, Sung YH, Huang SD (1999) *Analyst* **124**:1695
953. Gee Ak, Bruland KW (2002) *Geochim Cosmochim Acta* **66**:3063
954. Labonne M, Ottman DB, Luck JM (2002) *Applied Geochemistry* **17**:1351
955. Liu HW, Jiang SJ, Liu SH (1999) *Spectrochim Acta B* **54**:1367

956. Warnken KW, Gill GA, Wen L-S, Griffin LL, Santschi PH (1999) *J Anal Atomic Spectroscopy* 14:247
957. Wen B, Shan XQ, Liu RX, Tang HY (1999) *Fresen J Anal Chem* 363:251
958. Esser B, Volpe AM (2002) *Mar Chem* 79:67
959. Esser B, Volpe AM (2002) *Mar Chem* 36:2836
960. Worsfold PJ, Achterberg EP, Bowie AR, Sandford R, Montoura RF (2000) *Ocean Science and Technology* 1:71
961. Achterberg EP, Braungardt C, Whitworth DJ (2000) *Ocean Science and Technology* 1:277
962. Achterberg EP (2000) *Int J Environ Pollution* 13:249
963. Bermego Barrera P, Barciela Alonso MC, Ferron Novais M, Bermego Barrera A (1996) *Fresen Z Anal Chem* 355:174
964. Hirao Y, Fukumoto K, Sugisaki H, Kuimura K (1979) *Anal Chem* 51:651

6 Cations in Estuary, Bay, and Coastal Waters

6.1

Ammonium

Berg and Abullah [1] and Mantoura and Woodward [2] have described indophenol blue methods for the automated determination of ammonia in estuarine waters.

The reaction manifold describing the automated determination of ammonia is shown in Fig. 6.1. Two alternative modes of sampling are shown: discrete and continuous. Discrete 5 ml samples contained in ashed (450 °C) glass vials are sampled from an autosampler (Hook and Tucker model A40-11; 1.5 min sample/wash). For high-resolution work in the estuary, the continuous sampling mode is preferred. The indophenol blue complex was measured at 630 nm with a colorimeter and the absorbance recorded on a chart recorder.

Mantoura and Woodward [2] overcame the problem of magnesium precipitation by ensuring a stoichiometric excess of citrate (about 120%). These workers believe that “salt errors” occurring with estuarine samples originate from poor pH buffering rather than ionic strength variations. They, in fact, used phenol at a concentration of 0.06 M to make the system self-buffering. Even in the presence of 1 mg NH₃-N per litre the indophenol blue reaction will consume only 3% of the phenol leaving most of the phenol to act as a pH buffer. Ethanol was used to solubilise the high concentration of phenol used in the system. The salt error of this method, as determined by standard addition of ammonia into waters of different salinities, is shown in Fig. 6.2(a). When compared with other methods, the method displays minimal salt error (about 8%) even though the final pH of the river water mixture (pH 10.9) was greater than seawater (pH 9.9).

In addition to the chemical effects of varying salinity, there are optical interferences in colorimetric analysis which are peculiar to estuarine samples. Saline waters and river waters have, in the absence of colorimetric reagents, an apparent absorbance arising from:

1. Refractive bending of light beams by sea salts-“refractive index blank” [3]
2. Background absorbance by dissolved organics of riverine origin.

The former is a function of the optical geometry of the light beam and the flow cell, and the latter is related to the organic loading of river water. Figure 6.2(b)

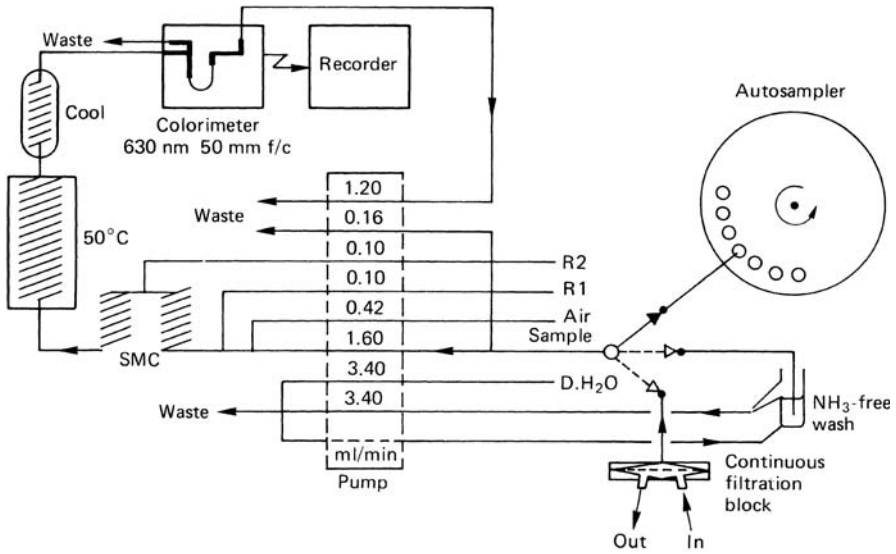

Figure 6.1. Manifold for the automatic determination of ammonia (# on pump tube R1 indicates Solvaflex tubing). Source: [2]

shows that both are linearly related to salinity, which makes optical blank corrections easy to apply to estuarine samples.

6.2 Arsenic

6.2.1 Hydride Generation Atomic Spectrometry

Amankwah and Fasching [4] have discussed the determination of arsenic (V) and arsenic (III) in estuary water by solvent extraction and atomic absorption spectrometry using the hydride generation technique.

6.3 Barium

6.3.1 Atomic Absorption Spectrometry

Epstein and Zander [5] determined barium directly in estuarine and sea water by graphite furnace atomic absorption spectrometry.

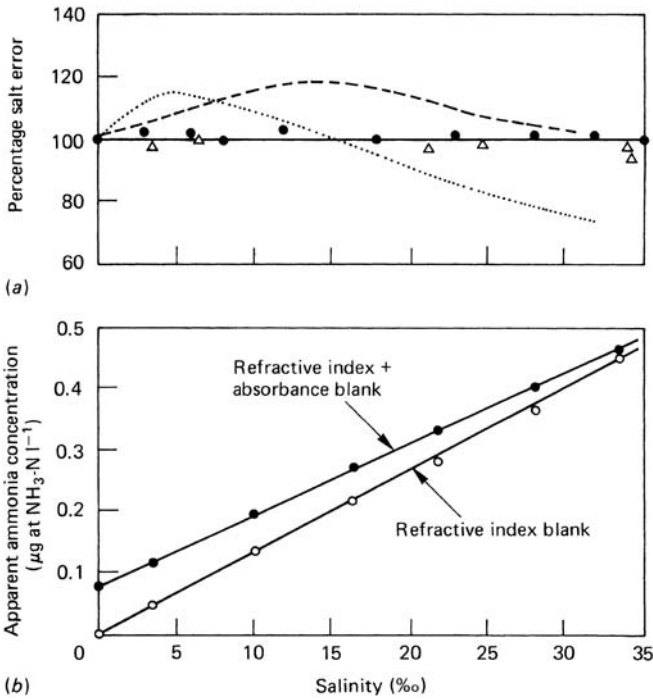

Figure 6.2. (a) The effects of salinity on the sensitivity of standard additions of ammonia in laboratory mixed waters (●) and in waters from the Tamar estuary (▲) expressed as percentage of response in river water. For comparison, the salt error curves reported by Loder and Gilbert [3] are also shown (... and ---, respectively). (b) Contribution of reactive index and organic absorbance to the optical blanks in the Chemlab Colorimeter. ● = River water-seawater mixture. ○ = De-ionized water-seawater mixture. Source: [2]

6.4 Cadmium

6.4.1 Atomic Absorption Spectrometry

Gardner [6] has reported a detailed statistical study involving ten laboratories of the determination of cadmium in coastal and estuarine waters by atomic absorption spectrometry. The maximum tolerable error was defined as 0.1 $\mu\text{g/l}$ or 20% of sample concentration, whichever is the larger. Many laboratories participating in this work did not achieve the required accuracy for the determination of cadmium in coastal and estuarine water. Failure to meet targets is attributable to both random and systematic errors.

6.5 Calcium and Magnesium

Titration

Arey et al. [35] have described a method for the determination of calcium and magnesium ions in estuarine waters. Calcium is determined by titration with a chelating agent ethylene bis oxyethylene nitrilo/tetra acetic acid and calcium and magnesium together with EDTA. A cupric ion-selective electrode is used for both determinations and the indicator is ethylene bis (oxyethylene-nitrilo) tetra-acetic acid cupric chelate for calcium alone and EDTA cupric chelate for the two ions together; the ratio of ammonium to associated ammonium hydroxide in the buffer solution must be carefully adjusted for each titration to give the proper cupric ion concentration. The method is suitable for routine analysis but gives consistently lower results than atomic absorption spectrometry.

The lower limit of detection of this method is 0.2 mg/l for calcium and magnesium.

6.6 Copper

6.6.1 Titration Procedure

Berger et al. [7] applied a fluorescence quenching titration method to the measurement of the complexation of copper (II) in the Gironde Estuary. Relatively high values of residual fluorescence after titration indicated that much organic fluorescing material does not bind to divalent copper. The titration was performed in a flow-through system thermostated at 25 °C under nitrogen. The pH is adjusted for each step at 8.0 with 0.01 M potassium hydroxide or nitric acid (pH 8.0 is very close to the natural pH of the Gironde waters). After the addition of copper (II) solution, the sample is circulated through the cuvette for several minutes before measurement. An increase in Rayleigh scattering, which was measured along with fluorescence, signifies aggregation. When Rayleigh scattering doubled its original value before copper (II) was added, the titration was stopped.

6.6.2 Anodic Stripping Voltammetry

Nelson [8] studied voltammetric measurement of copper (II)-organic interactions in estuarine waters. Based on results of previous studies on the effects of organic matter on adsorption of copper at mercury surfaces, Nelson developed a method to evaluate the interactions between divalent copper and

organic ligands, based on ligand exchange. The copper/organic species competed with glycine, which formed copper glycinate and those two complexes could be distinguished voltammetrically, since copper glycinate gave a higher surface excess of copper at a gelatin-coated hanging-drop mercury electrode. The method was applied successfully to both chloride media and estuarine waters. It was demonstrated that estuarine waters contained two types of ligand capable of binding divalent copper; humic material with polyelectrolyte type binding, and discrete ligands, with stability constants of about 10^9 . The extent of binding by humic material decreased down the estuary as a result of dilution and increased salinity.

Nelson [9] also examined the role of organic matter in the uptake of copper at a mercury electrode. Experiments were carried out on the induced adsorption of copper on a hanging-drop mercury electrode in a stirred solution, using chloride media with added complexing ligand and organic surfactant, and in estuarine water containing added surfactant (gelatin). Copper chloride was the most important copper species adsorbed on the electrode, and adsorption was enhanced by the presence of organic films, which could provide a critical pathway for reducing, divalent copper in estuarine waters. The composition of organic monolayers could be determined by utilising adsorption of divalent and monovalent copper as electroactive probes and determining solution copper-organic binding.

Shuman and Michael [10] applied a rotating disk electrode to the measurement of copper complex dissociation rate constants in marine coastal waters. An operational definition for labile and non-labile metal complexes was established on kinetic criteria. Samples collected off the mid-Atlantic coast of USA showed varying degrees of copper chelation. It is suggested that the technique should be useful for metal toxicity studies because of its ability to measure both equilibrium concentrations and kinetic availability of soluble metal.

Wang et al. [11] used a remote electrode operated in the potentiometric stripping mode, for the continuous boatside determination of copper distribution patterns in San Diego Bay (CA, USA).

6.7

Mercury

6.7.1

Miscellaneous

Bio-assay methods have been used to obtain estimates of low mercury concentrations (5–20 $\mu\text{g/l}$) in seawater (Davies and Pirie [13]). This method is useful for detecting comparatively small enhancements over background mercury concentrations in estuarine and sea water.

This method consists of suspending 70 mussels (*Mytilus edulis*) each of a standard weight, for a standard time in a plastic coated wire cage 2 m below

the surface. Mercury in the mussels was determined by cold vapour atomic absorption spectrometry [14, 15]. The procedure is calibrated by plotting the determined mercury content of mussels against the mercury content of the sea water in the same area.

6.8

Manganese

6.8.1

Polarography

Knox and Turner [12] have described a polarographic method for manganese (II) in estuarine waters which covers the lower concentration range 10–300 $\mu\text{g/l}$. The method, which is specific to manganese (II) and its labile complexes, is used in conjunction with a colorimetric technique to compare the levels of manganese (II) and total dissolved manganese in an estuarine system. They showed that polarographically determined manganese (II) can vary widely from 100% to less than 10% of the total dissolved manganese, determined spectrophotometrically at 450 nm by the formaldoxine method [16] calibrated in saline medium to overcome any salt effects. It is suggested that the manganese not measured by the polarographic method is in colloidal form.

6.9

Selenium

6.9.1

Hydride Generation Graphite Furnace Atomic Absorption Spectrometry

Willie et al. [17] used the hydride generation graphite furnace atomic absorption spectrometry technique to determine selenium in saline estuary waters and sea waters. A Pyrex cell was used to generate selenium hydride which was carried to a quartz tube and then a preheated furnace operated at 400 °C. Pyrolytic graphite tubes were used. Selenium could be determined down to 20 ng/l. No interference was found due to, iron copper, nickel, or arsenic.

Cutter [18] has studied the application of the hydride generation method to the determination of selenium in saline waters.

6.10

Tin

6.10.1

High-Performance Liquid Chromatography

Tributyltin has been determined in estuarine waters by high-performance liquid chromatography with fluorometric detection in a method described

by Ebdon and Alonso [19]. The Bu_3Sn^+ is quantitatively retained from 100–500 mL of sample on a 4 cm long ODS column. The ODS column was back-flushed with methanol-water containing ammonium acetate onto a Partisil SCX analytical column. The eluent was mixed with acetic acid, Morin, and Triton X-100 for fluorometric detection.

6.11

Multication Analysis

6.11.1

Heavy Metals, Isotope Dilution, Spark Source Mass Spectrometry, and Inductively Coupled Plasma Atomic Emission Spectrometry

The determination of trace elements in coastal and seawater is pursued with great difficulty [20]. Quantitation of extremely low concentrations of analyte (0.02–10 $\mu\text{g/l}$) accompanied by a matrix consisting of 3.5% dissolved solids in sea water imposes great demands on instrumental techniques. Sample preparation schemes designed to both preconcentrate the trace elements and separate them from major interfering components prior to analysis are numerous. All such methods invariably increase sample manipulation and the relatively large amounts of reagents and container surfaces brought into contact with the sample often give rise to unacceptably high and/or random procedural blanks. These problems are exacerbated by a lack of standard reference materials which would permit detection of systematic errors such as contamination or analyte losses introduced during sample manipulation and the presence of matrix or spectral interferences perturbing instrument response.

A logical approach which serves to minimise such uncertainties is the use of a number of distinctly different analytical methods for the determination of each analyte wherein none of the methods would be expected to suffer identical interferences. In this manner, any correspondence observed between the results of different methods implies that a reliable estimate of the true value for the analyte concentration in the sample has been obtained. To this end Sturgeon et al. [21] carried out the analysis of coastal seawater for the above elements using isotope dilution spark source mass spectrometry, GFA-AS, and ICP-ES following trace metal separation-preconcentration (using ion exchange and chelation-solvent extraction), and direct analysis by GFA-AS. These workers discuss analytical advantages inherent in such an approach.

Table 6.1 shows the results obtained by Sturgeon et al. [21] for a stored coastal water sample. The mean concentrations and standard deviations of replicates (after rejection of outliers on the basis of a simple *c* test-function) are given for each method of analysis. Each mean reflects the result of four or more separate determinations by the indicated method [21].

Table 6.1. Analysis of seawater sample A [21]

Element	Concentration, $\mu\text{g/l}$			
	GFAAS		ICPES	IDSSMS
	Direct	Chelation-extraction	Ion exchange	Ion exchange
Fe	1.6 ± 0.2^a	1.5 ± 0.1	1.5 ± 0.6	1.4 ± 0.1
Mn	1.6 ± 0.1	1.4 ± 0.2	1.5 ± 0.1	ND ^b
Cd	0.20 ± 0.04	0.24 ± 0.04	ND	0.28 ± 0.02
Zn	1.7 ± 0.2	1.9 ± 0.2	1.5 ± 0.4	1.6 ± 0.1
Cu	ND	0.6 ± 0.2	0.7 ± 0.2	0.7 ± 0.1
Ni	ND	0.33 ± 0.08	0.4 ± 0.1	0.37 ± 0.02
Pb	ND	0.22 ± 0.04	ND	0.35 ± 0.03
Co	ND	0.018 ± 0.008^c	ND	0.020 ± 0.003^d

^a Precision expressed as standard deviation

^b ND: Not determined

^c Preconcentrated hundredfold by ion exchange

^d Spark source mass spectrometry – internal standard method

Sturgeon et al. [21, 22] conclude that direct analysis by GFA-AS is a fast, accurate method for the determination of iron, manganese, zinc, and cadmium in seawater when these elements are present at concentrations above 0.2, 0.2, 0.4 and 0.01 $\mu\text{g/l}$, respectively (offshore seawater concentrations of these metals are: iron $\sim 0.5 \mu\text{g/l}$, manganese $\sim 0.05 \mu\text{g/l}$, zinc $\sim 0.2 \mu\text{g/l}$, and cadmium $\sim 0.05 \mu\text{g/l}$). Below these levels, and for the other elements studied, chelation-solvent extraction using ammonium pyrrolidine oxine diethyldithiocarbamate/methyl isobutyl ketone in combination with a back-extraction into an acidic aqueous phase prior to determination by GFA-AS is the most useful technique for multielement determinations when small volumes of seawater are available (e.g., $50 \times$ preconcentration on 100 mL aliquot of seawater). If significantly greater preconcentration is required, or if greater volumes of preconcentrate solution are needed as, for example, when analysis is completed by ICP-ES, the more laborious method of ion exchange (using Chelex 100) may be used.

Although ICP-ES is a multielement technique, its inferior detection limits (relative to GFA-AS) necessitate the processing of relatively large volumes of seawater. 250 mL aliquots were found to be useful for the analysis of iron, manganese, zinc, copper, and nickel. Extension of the method to include cadmium, cobalt, chromium, and lead would require improvements in the preconcentration procedure.

Apte and Gunn [23] used liquid-liquid extraction, involving 1:1:1 trichloroethane extraction of the ammonium pyrrolidine dithiocarbamates to concentrate copper, nickel, lead, and cadmium from estuary water. (Detection limits

achieved using electrothermal atomic absorption spectrometry were, respectively, 0.3, 0.02, 0.7, and 0.5 $\mu\text{g/l}$).

Stein et al. [24] have described a simplified, and rapid GFA-AS method for determining low concentration of cadmium, lead, and chromium in estuarine waters. To minimise matrix interferences, nitric acid and ammonium nitrate are added for cadmium and lead; nitric acid only is added for chromium. Then, 10, 20 or 50 μl of the sample or standard (the amount depending on the sensitivity required) is injected into a heated graphite atomiser, and specific atomic absorbance is measured. Analyte concentrations are calculated from calibration curves for standard solutions in demineralised water for chromium or an artificial sea water medium for lead and cadmium.

Detection limits ($\mu\text{g/l}$), were 0.1 for cadmium, 4 for lead, and 0.2 for chromium. For cadmium (0.5 and 5 $\mu\text{g/l}$), lead (4 and 50 $\mu\text{g/l}$), and chromium (1 and 10 $\mu\text{g/l}$) in half-strength artificial seawater, the relative standard deviations ($n = 10$) were 20 and 0.5, 18 and 10.4, and 25.0 and 8.0%, respectively.

Pellenberg and Church [25] sampled stored and processed saline water samples from the Delaware Bay estuary in a variety of ways to allow different methods of maintaining their integrity to be compared. Samples were processed onboard ship, immediately after collection, by extraction with ammonium pyrrolidinedithiocarbamate in methyl isobutyl ketone.

Duplicate samples were processed onshore after a variety of storage procedures. All samples were analysed for copper and iron by GFA-AS. Only samples filtered ($< 1 \mu\text{m}$), acidified, and stored frozen gave extractable copper and iron results comparable with those for samples extracted immediately after collection. Cold storage with sample acidification in polyethylene containers appeared less satisfactory. Organic extracts from samples processed onboard are best retained in all-Teflon containers pending complete digestion and analysis onshore. Unless clean (ultra-filtered air) conditions can be ensured onboard, the estuarine water samples are best returned in a filtered, acidified, and frozen condition for onshore processing.

Gardner and Yates [26] developed a method for the determination of total dissolved cadmium and lead in estuarine waters. Factors leading to the choice of a method employing extraction by chelating resin, and analysis by carbon furnace atomic absorption spectrometry, are described. To ensure complete extraction of trace metals, inert complexes with humic-like material are decomposed by ozone [27]. The effect of pH on extraction by and elution from chelating resin is discussed, and details of the method were presented. These workers found that at pH 7 only 1–2 minutes treatment with ozone was needed to completely destroy complexing agents such as EDTA and humic acid in the samples.

Kingston et al. [32] preconcentrated the eight transition elements cadmium, cobalt, copper, iron, manganese, nickel, lead, and zinc from estuarine and seawater using solvent extraction/chelation and determined them at sub ng/l levels by GFA-AS.

Yamamoto et al. [33] have studied the differential determination of heavy metals according to their oxidation states by flameless atomic absorption spectrometry combined with solvent extraction with ammonium pyrrolidinedithiocarbamate or sodium diethyldithio-carbamate.

6.11.2

Anodic Stripping Voltammetry

Heavy Metals

Batley [28] examined the techniques available for the in situ electrodeposition of lead and cadmium in estuary water. These included anodic stripping voltammetry at a glass carbon thin film electrode and the hanging drop mercury electrode in the presence of oxygen and in situ electrodeposition on mercury coated graphite tubes. Batley [28] found that in situ deposition of lead and cadmium on a mercury coated tube was the more versatile technique. The mercury film, deposited in the laboratory, is stable on the dried tubes which are used later for field electrodeposition. The deposited metals were then determined by electrothermal atomic absorption spectrometry, Hasle and Abdullah [29] used differential pulse anodic stripping voltammetry in speciation studies on dissolved copper, lead, and cadmium in coastal sea water.

Clem and Hodgson [27] discuss the temporal release of traces of cadmium and lead in bay water from EDTA, ammonium pyrrolidine-dithiocarbamate, humic acid and tannic acid after treatment of the sample with ozone. Anodic scanning voltammetry was used to determine elements.

Heavy Metals, Aluminium, and Vanadium

The determination of trace metals in estuarine, marine, and other waters is the subject of a booklet published by the Standing Committee of Analysts set up by the Department of the Environment UK [30].

The elements covered are aluminium, cadmium, chromium, cobalt, copper, iron, lead, manganese, nickel, vanadium, and zinc. Electrothermal atomic absorption and anodic and cathodic scanning voltammetric methods are discussed.

6.11.3

Cathodic Stripping Voltammetry

Newton and Van den Berg [31] applied cathodic stripping chronopotentiometry with continuous flow to the determination of nanomolar concentrations of nickel cobalt, copper, and uranium in estuary water.

6.11.4

Emission Spectrometry

Arsenic and Antimony

Braman et al. [34] used sodium borohydride to reduce arsenic and antimony in their trivalent and pentavalent states to the corresponding hydrides. Total arsenic and antimony are then measured by their spectral emissions, respectively, at 228.8 nm and 242.5 nm. Limits of detection are 0.5 ng for antimony and 1 ng for arsenic, copper, and silver. Oxidants interfere in this procedure.

6.11.5

Hydride Generation Atomic Spectrometry

Arsenic and Antimony

It has been reported that the differential determination of arsenic [36–41] and also antimony [42, 43] is possible by hydride generation-atomic absorption spectrophotometry. The HGA-AS is a simple and sensitive method for the determination of elements which form gaseous hydrides [35, 44–47] and mg/l levels of these elements can be determined with high precision by this method. This technique has also been applied to analyses of various samples, utilizing automated methods [48–50] and combining various kinds of detection methods, such as gas chromatography [51], atomic fluorescence spectrometry [52, 53], and inductively coupled plasma emission spectrometry [47].

Yamamoto et al. [33] applied this technique to the determination of arsenic (III), arsenic (V), antimony (III), and antimony (V) in Hiroshima Bay Water. These workers used a HGA-A spectrometric method with hydrogen-nitrogen flame using sodium borohydride solution as a reductant. For the determination of arsenic (III) and antimony (III) most of the elements, other than silver (I), copper (II), tin (II), selenium (IV), and tellurium (IV), do not interfere in at least 30 000-fold excess with respect to arsenic (III) or antimony (III). This method was applied to the determination of these species in sea water and it was found that a sample size of only 100 ml is enough to determine them with a precision of 1.5–2.5%. Analytical results for surface sea water of Hiroshima Bay were 0.72 $\mu\text{g/l}$, 0.27 $\mu\text{g/l}$, and 0.22 $\mu\text{g/l}$, for arsenic (total), arsenic (III), and antimony (total), respectively, but antimony (III) was not detected. The effect of acidification on storage was also examined.

6.11.6

Inductively Coupled Plasma Mass Spectrometry

Heavy Metals

Beck et al. [61] used flow injection magnetic sector ICP-MS to determine cadmium, copper, nickel, zinc, and manganese in estuarine waters. The online preconcentration system used Toyopearl A-T Chelate 650 H as chelating resin, and was validated for an alkaline water standard reference material (SLEW-2).

6.11.7

Preconcentration Techniques

Techniques employed for the preconcentration, coastal, and estuary waters are reviewed in Table 6.2.

Table 6.2. Preconcentration techniques. Cations in estuary and coastal waters

Element	Preconcentration method	Analytical finish	Detection limit, $\mu\text{g/l}$	Reference
Cr	Coprecipitation with lead sulfate on lead phosphate	NAA γ -spectrometry	0.1	[54]
Sb	Sb(III) and Sb(V) converted to ammonium pyrrolidine dithiocarbamate complexes and adsorbed onto C_{18} bonded silica, then desorption	Graphite furnace AAS	0.05	[55]
Cu, Cd, Pb, Zn	Adsorbed onto carboxylated polyethylene-imine-polymethylene phenyl isocyanate	ICPS	–	[56]
Cu, Ni, Pb, Cd	Liquid-liquid extraction of ammonium pyrrolidine dithiocarbamate complexes	AAS	Cu – 0.3 Ni – 0.02 Pb – 0.5 Cd – 0.5	[57]
Fe, Mn, Cd, Zn, Cu, Ni, Pb, Co	Solvent extraction of ammonium pyrrolidine dithiocarbamate complexes with MIBK and preconcentration onto Chelex 100 resin	AAS	0.01–0.4	[21]
Cu, Fe	Chelation-solvent extraction	AAS	–	[25]
Miscellaneous heavy metals	Formation of ammonium pyrrolidine dithiocarbamate complexes and solvent extraction	Flameless AAS	–	[33]
Fe, Mn, Cu, Ni, Cd, Pb, Zn	Adsorption onto Chelex 100 resin	Flameless AAS	–	[58]
Cd, Cu, Fe, Pb	Dithiocarbamate complexes extracted into Freon	AAS	–	[59]
Fe, Mn, Cu, Ni, Cd, Pb, Zn	Adsorption onto Chelex 100 resin	–	–	[58]

Source: Author's own files

6.11.8 Speciation

Hasle and Abdullah [29] fractionated and speciated dissolved copper, lead, and cadmium in coastal waters from the Inner Oslofjord, Norway. They examined the fractions by an operational scheme which involves ultra-filtration followed by determination of labile, acid soluble and total copper, lead, and cadmium by differential pulse anodic stripping voltammetry. It was found that cadmium was present entirely in low molecular weight labile species; lead was mainly in non-labile low molecular weight species, with half of the total lead probably occurring in low molecular weight organometallic compounds; copper distribution was irregular, with extensive organic and colloidal association.

Batley et al. [60] studied the speciation of the same three elements in estuarine and coastal waters. They evaluated the potential of a heavy metal speciation scheme to reflect differences in metal distributions within a water mass in a study of soluble copper, lead, and cadmium speciation in water samples from five stations in the Port Hacking Estuary (Australia) and one coastal Pacific Ocean station. The observed metal distributions were found to be consistent with the other measured physical and chemical properties of the sampled waters. In all samples, the percentages of metals associated with colloidal matter were high, amounting to 40–60% of total copper, 45–70% of total lead, and 15–35% of total cadmium. The scheme was used to follow changes in metal speciation under different sample storage conditions. Storage at 4 °C in polyethylene containers was shown to prevent losses or changes in speciation of the metals studied.

References

1. Berg BR, Abdullah MI (1977) *Water Res* **11**:637
2. Mantoura RFC, Woodward EM (1983) *Estuar Coast Shelf Sci* **17**:219
3. Loder TC, Gilbert PM (1976) Blank and salinity corrections for automated nutrient analysis of estuarine and sea waters. University of New Hampshire Contribution UNH-59-JR101 to Technicon International Congress December 13–15
4. Amankwah D, Fasching P (1979) *Anal Chem* **51**:1101
5. Epstein HS, Zander AT (1979) *Anal Chem* **51**:915
6. Gardner MJ (1987) UK Analytical Quality Control for Trace Metals in the Coastal and Marine Environment, the Determination of Cadmium. Report PRS 1516-M, Water Res Centre, Medmenham, UK
7. Berger P, Ewald M, Lin D, Weber JH (1984) *Mar Chem* **14**:289
8. Nelson A (1985) *Anal Chim Acta* **169**:287
9. Nelson A (1985) *Anal Chim Acta* **169**:273
10. Shuman S, Michael LC (1978) *Environ Sci Technol* **12**:1069
11. Wang J, Foster N, Armalis S, Larson D, Zirino A, Olsen K (1995) *Anal Chim Acta* **310**:223
12. Knox S, Turner DR (1980) *Estuar Coast Mar Sci* **10**:317
13. Davies IM, Pirie JM (1978) *Mar Pollut Bull* **9**:128

14. Topping G, Pirie JM, Graham WC, Shepherd RM (1975) *An Examination of the Heavy Metal Levels in Muscle, Kidney, and Liver in Relation to Year, Class, Area of Sampling and Season ICE5CM*, E:37
15. Topping G, Pirie JM (1972) *Anal Chim Acta* **62**:200
16. Department of the Environment and the National Water Council, Standing Committee of Analysts Manganese in Raw and Potable Waters by Spectrophotometry (using Formaldoxime) 1977 (1978) *Methods for The Examination of Waters and Associated Materials*, HMSO London UK
17. Willie SN, Sturgeon RE, Bermna SS (1986) *Anal Chem* **58**:1140
18. Cutter GA (1978) *Anal Chim Acta* **98**:59
19. Ebdon L, Alonso JIG (1987) *Analyst* **112**:1551
20. Riley JP, Skirrow G (1965) *Chemical Oceanography* vol 3. Academic Press, London, pp 269–408
21. Sturgeon RE, Berman SS, Desauliniers JAH, Mykytiuk AP, McLaren JW, Russell DS (1980) *Anal Chem* **52**:1585
22. Sturgeon RE, Berman SS, Desauliniers JAH, Russell DS (1979) *Anal Chem* **51**:2364
23. Apte Sc, Gunn AM (1987) *Anal Chim Acta* **193**:147
24. Stein VB, Canelli B, Richards AM (1980) *Int J Environ Anal Chem* **8**:99
25. Pellenberg RE, Church TM (1978) *Anal Chim Acta* **97**:81
26. Gardner J, Yates J (1979) The determination of dissolved cadmium and lead in estuarine water samples. CEP Consultants Ltd., Edinburgh UK, pp 427–430
27. Clem RG, Hodgson AT (1978) *Anal Chem* **50**:102
28. Batley GL (1981) *Anal Chim Acta* **124**:121
29. Hasle JR, Abdullah MI (1981) *Mar Chem* **10**:487
30. Standing Committee of Analysts Department of the Environment UK (1987) *Methods for the Determination of Metals*
31. Newton MP, Van den Berg CMG (1987) *Anal Chim Acta* **199**:59
32. Kingston HM, Barnes IL, Brady TJ, Rains TC (1978) *Anal Chem* **50**:2064
33. Yamamoto M, Urata K, Murashige K, Yamamoto Y (1981) *Spectrochim Acta* **36B**:671
34. Braman RS, Justen LL, Foreback CC (1972) *Anal Chem* **44**:2195
35. Arey FK, Chamblce JW, Heckel E (1980) *Int J Environ Anal Chem* **7**:285
36. Agget J, Aspell AC (1976) *Analyst* **101**:341
37. Braman RS, Johnson DL, Foreback CC, Ammins JM, Bricher JL (1977) *Anal Chem* **49**:621
38. Andreae MO (1977) *Anal Chem* **49**:820
39. Shaikh Au, Tallman DE (1978) *Anal Chim Acta* **98**:251
40. Feldman C (1979) *Anal Chem* **51**:664
41. Nakashima S (1979) *Analyst* **104**:172
42. Yamamoto M, Urata K, Yamamoto Y (1981) *Anal Lett* **41**:21
43. Nakashima S (1980) *Analyst* **105**:732
44. Yamamoto Y, Kumamaru T, Hayashi Y, Tsujino R (1972) *Anal Lett* **5**:419
45. Yamamoto Y, Kumamaru T, Hayashi Y, Tsujino R (1972) *Anal Lett* **5**:717
46. Yamamoto Y, Kumamaru T (1976) *Fresen Z Anal Chem* **281**:353
47. Yamamoto Y, Kumamaru T (1976) *Fresen Z Anal Chem* **282**:193
48. Chan CY, Baig MWA, Pitts AE (1979) *Anal Chim Acta* **111**:169
49. Peter E, Growcock G, Strung G (1979) *Anal Chim Acta* **104**:177
50. Agemian H, Cheam V, Thomson R (1978) *Anal Chim Acta* **101**:193
51. Skogerboe RK, Bejmuk AP (1977) *Anal Chim Acta* **94**:297
52. Tsujii K, Kuga K (1978) *Anal Chim Acta* **97**:51
53. Nakahara T, Kobayashi S, Wakisaka T, Musha S (1980) *Appl Spectros* **34**:194
54. Zhang D, Smith RS (1983) *Anal Chem* **55**:100

55. Sturgeon RE, Willie SN, Berman SS (1985) *Anal Chem* **57**:6
56. Horvath Z, Barnes RM (1986) *Anal Chem* **58**:1352
57. Apte SC, Gunn AM (1987) *Anal Chim Acta* **193**:147
58. Paulson AJ (1986) *Anal Chem* **58**:183
59. Danielsson L-G, Magnusson B, Westerlund S, Zhang K (1982) *Anal Chim Acta* **144**:183
60. Batley GE, Kramer KJM, Vinhas T (1996) *Fresen J Anal Chem* **354**:397
61. Beck NG, Franks RP, Bruland KW (2002) *Anal Chim Acta* **455**:11

7 Radioactive Elements

7.1

Naturally Occurring Cations

7.1.1

Actinium

Lin [1] used coprecipitation with lead sulfate to separate $^{237}\text{actinium}$ from seawater. The $^{237}\text{actinium}$ was purified by extraction with HDEHP and determined by α -spectrometry with a Si (Au) surface barrier detector. The method has a sensitivity of 10^{-3} Ci/g of ashed sample.

7.1.2

Polonium and Lead

Skwarzek and Bojanowski [2] in a study of the accumulation of $^{210}\text{polonium}$ in Southern Baltic seawater showed that the mean concentration was 0.49 mBq/dm^3 , of which approximately 80% was dissolved. $^{210}\text{Polonium}$ concentrations in phytoplankton and zooplankton were 21–61 and 21–451 mBq/g dry weight, respectively. Mean $^{210}\text{polonium}$ concentration factors were 5000 in phytoplankton, 18 300 in macrozooplankton, and 42 000 in mesozooplankton. The higher mean $^{210}\text{polonium}$ concentration in mesozooplankton from the Slupsk Trough compared with that in mesozooplankton from the Gdansk basin (214 against 55 mBq/g dry weight) might have been due to blue-green algal blooms in the Gdansk basin.

Various workers [3–7] have discussed the determination of polonium and lead in seawater.

Similar affinity of polonium and plutonium for marine surfaces implies that studies of the more easily measured polonium might be valuable in predicting some consequences of plutonium disposal in the oceans [8–11]. Rates at which plutonium and polonium deposit out of seawater onto surfaces of giant brown algae and “inert” surfaces, such as glass and cellulose, suggest that both nuclides are associated in coastal seawater with colloidal sized species having diffusivities of about $3 \times 10^{-7}\text{ cm}^2/\text{s}$. The parallel behaviour possibly

represents an initial step in the incorporation of both α -radioactive heavy elements into marine food chains and/or their transport by the greater activity concentrations found on marine surfaces and in seawater, about 200 times that of plutonium.

Tsunogai and Nozaki [6] analysed Pacific Oceans surface water by consecutive coprecipitations of polonium with calcium carbonate and bismuth oxychloride after addition of lead and bismuth carriers to acidified seawater samples. After concentration, polonium was spontaneously deposited onto silver planchets. Quantitative recoveries of polonium were assumed at the extraction steps and plating step. Shannon et al. [7], who analysed surface water from the Atlantic Ocean near the tip of South Africa, extracted polonium from acidified samples as the ammonium pyrrolidine dithiocarbamate complex into methyl isobutyl ketone. They also autoplated polonium onto silver counting disks. An average efficiency of 92% was assigned to their procedure after calibration with ^{210}Po – ^{210}Pb tracer experiments.

Shannon [3] determined ^{210}Po and ^{210}Pb in seawater. These two elements are extracted from seawater (at pH 2) with a solution of ammonium pyrrolidine dithiocarbamate in isobutyl methyl ketone (20 ml organic phase to 1.5 litres of sample). The two elements are back-extracted into hydrochloric acid and plated out of solution by the technique of Flynn [12] but with use of a PTFE holder in place of the Perspex one, and the α -activity deposited is measured. The solution from the plating-out process is stored for 2–4 months, then the plating-out and counting are repeated to measure the build-up of ^{210}Po from ^{210}Pb decay and hence to estimate the original ^{210}Pb activity.

Nozaki and Tsunogai [4] determined ^{210}Pb and ^{210}Po in seawater. The ^{210}Pb and ^{210}Po in a 30–50 litre sample are coprecipitated with calcium carbonate together with lead and bismuth and are then separated from calcium by precipitation as hydroxides. The precipitate is dissolved in 0.5 M hydrochloric acid, and ^{210}Po is deposited spontaneously from this solution on to a silver disk and is determined by α -spectrometry. Chemical yields of lead and bismuth are determined in a portion of the solution from which the polonium has been deposited; hydroxides of lead and other metals are precipitated from the remainder of this solution and after a period exceeding three months, the ^{210}Po produced by decay of ^{210}Pb is determined as before. The activity of ^{210}Pb is calculated from the activity of ^{210}Po . The method was used to determine the vertical distribution of lead and ^{210}Po activities in surface layers of the Pacific Ocean.

Cowen et al. [5] showed that polonium can be electrodeposited onto carbon rods directly from acidified seawater, stripped from the rods and auto-plated onto silver counting disks with an overall recovery of tracer of $85 \pm 4\%$ for an electrodeposition time of 16 h [13].

These workers compared two procedures for concentrating ^{210}Po from seawater:

1. Coprecipitation upon partial precipitation of the natural calcium and magnesium with sodium hydroxide.
2. Electrodeposition of polonium directly from acidified seawater onto carbon rods.

Polonium thus concentrated was autoplated onto silver counting disks held in spinning Teflon holders.

Recoveries of 208 polonium tracer in the precipitation method were $77 \pm 7\%$ ($n = 8$) compared with $40 \pm 2\%$ ($n = 2$) for the electrodeposition method with 16 h plating time, $64 \pm 1\%$ ($n = 2$) in 24 h, and $85 \pm 4\%$ ($n = 2$) in 48 h.

Biggin et al. [115] have described a time efficient method for the determination of 210 lead, 210 bismuth, and 210 polonium activities in seawater using liquid scintillation spectrometry.

7.1.3

Radium

Orr [14] has proposed a scintillation and β - γ coincidence methods for the determination as measured by 220 radon emanation.

Burnett and Tai Wei-Chieh [15] used α liquid scintillation to determine radium radionuclides in seawater. The method was applied in the 7–35 dpm 100 kg^{-1} -range using 1 litre samples.

Cohen and O'Nions [16] determined femtogram quantities of radium radionuclides in seawater by thermal ionisation mass spectrometry.

Bettoli et al. [17] has described a shipboard system to measure the concentrations of 222 radium and 226 radium in sea and coastal waters.

7.1.3.1

Radium, Barium, and Radon

Perkins [18] carried out radium and radiobarium measurements in seawater by sorption and direct multidimensional gamma-ray spectrometry. The procedure described includes the removal of radium and barium from water samples on sorption beds of barium sulfate impregnated alumina (0.5–1 cm thick) and direct counting of these beds on a multidimensional γ -ray spectrometer. The radioisotopes can be removed at linear flow rates of sample of up to 1 m/min.

Oceanographers have developed methods to measure the 228 radium content of seawater, as it is a useful tracer of mixing in the ocean. These procedures are based on concentrating radium from a large volume of seawater, removing all 228 thorium from the sample and ageing the sample while a new generation of 228 thorium partially equilibrates with 228 radium. After storage periods of 6–12 months, the sample is spiked with 230 thorium and after ion exchange and solvent exchange separations, the thorium isotopes are measured in a γ -ray spectrometer system utilising a silicon surface barrier detector.

Early work was based on concentrating the radium from the seawater sample by adding barium and coprecipitating with barium sulfate. This concentration procedure has been replaced by one involving the extraction of radium from seawater on acrylic fibre coated with manganese dioxide [19, 20] (Mn fibres). By use of this technique, volumes of 200–2000 litres may be sampled routinely.

Measurements of ^{226}Ra are simpler than those for ^{228}Ra and are more precise. These measurements are generally made by concentrating the radium from up to a few litres via barium sulfate precipitation followed by thick source α counting or by ^{222}Rn extraction following dissolution of barium sulfate [21].

Oceanographers use different techniques for measuring ^{226}Ra in seawater. Some workers store the sample in a 20 l glass bottle and extract successive generations of ^{222}Rn [22, 23]. Others quantitatively extract the radium onto manganese fibre and measure radon directly emanating from the manganese fibre [24] or in a hydrochloric acid extract from the fibres. The ^{222}Rn activity is then determined by α -scintillation counting. All of these techniques give high levels of reproducibility and accuracy as determined by the oceanographic consistency of the results [22, 23].

The introduction of high-resolution, high-efficiency γ -ray detectors composed of lithium-drifted germanium crystals has revolutionised γ -measurement techniques. Thus, γ -spectrometry allows the rapid measurement of relatively low-activity samples without complex analytical preparations. A technique described by Michel et al. [25] uses Ge(Li) γ -ray detectors for the simultaneous measurements of ^{228}Ra and ^{226}Ra in natural waters. This method simplifies the analytical procedures and reduces the labour while improving the precision, accuracy, and detection limits.

In this method the radium isotopes are preconcentrated in the field from 100 to 1000 litre water sample onto manganese impregnated acrylic fibre cartridges, leached from the fibre and coprecipitated with barium sulfate. This manganese fibre γ -ray technique is shown to be more accurate than the ^{228}Ac methods recommended by the Environmental Protection Agency [26] and as accurate but more rapid than the ^{228}Th ingrowth procedure.

Key et al. [27] have described improved methods for the measurement of radon and radium in seawater and marine sediments using manganese dioxide impregnated fibres. The basic method that these workers used was that of Broecker [28]. Seawater samples were taken in 30 litre Niskin bottles.

7.1.3.2

Radium, Thorium, and Lead

^{226}Ra , ^{230}Th , and ^{210}Pb in large volumes of seawater have been collected on manganese oxyhydroxide-impregnated cartridges prior to determination by radiochemical methods [29].

Colley and Thomas [29] determined $^{226}\text{radium}$, $^{230}\text{thorium}$, and $^{210}\text{lead}$ in large sample volumes of seawater. In situ pumps were used to collect particles on a $1\ \mu\text{m}$ filter. The dissolved species were collected on manganese oxyhydroxide impregnated cartridges prior to final analysis for nuclides.

Baskaran et al. [30] pumped seawater at 35 l/min and collected dissolved species on cartridges prior to determining radium, thorium, and lead by γ counting methods.

7.1.4

$^{99}\text{Technetium}$

Chen et al. [31] preconcentrated $^{99}\text{technetium}$ in seawater on an anion exchange column to determination in amounts down to $3\ \text{mBq/m}^3$.

Ballestra et al. [32] described a radiochemical measurement for determination of $^{99}\text{technetium}$ in rain, river, and seawater, which involved reduction to technetium (IV), followed by iron hydroxide precipitation and oxidation to the heptavalent state. Technetium (VII) was extracted with xylene and electrodeposited in sodium hydroxide solution. The radiochemical yield was determined by gamma counting on an anticoincidence shield GM-gas flow counter. The radiochemical yield of 50 to 150 litre water samples was 20–60%.

$^{99}\text{Technetium}$ has been determined in seawater by inductively coupled plasma mass spectrometry after preconcentration by coprecipitation with iron hydroxide [33].

Keith-Roach et al. [114] has described a radiochemical separation and ICPS protocol for determining $^{99}\text{technetium}$ in seawater.

7.1.5

Thorium

In recent years, there has been an increasing level of interest in the use of $^{234}\text{Th}/^{238}\text{U}$ disequilibrium in the marine environment to study geochemical processes with short time scales (up to 100 days), particularly those associated with carbon cycling in the oceans [34–36] and the partitioning of pollutants between the dissolved and particulate phases [37, 38]. However, the analysis of $^{234}\text{thorium}$ is constrained by its short half-life and its low concentration in seawater, so appropriate analytical techniques must be rapid and sensitive and preferably should allow shipboard analysis.

Secondary ion mass spectrometry has been used to determine low levels of $^{230}\text{thorium}$ and $^{232}\text{thorium}$ in seawater [39].

Thermal ionisation mass spectrometry has been used to determine pg/kg levels of $^{230}\text{thorium}$ and $^{232}\text{thorium}$ in seawater [40].

Pates et al. [41] have described a liquid scintillation spectrometry method for the determination of $^{234}\text{thorium}$ in seawater with $^{230}\text{thorium}$ as the yield

tracer. ^{234}Th is separated from the dissolved phase by a ferric hydroxide precipitation and is then purified using ion exchange chromatography. The counting source is prepared by taking the sample to dryness in a vial, redissolving in acid, and mixing with a scintillation cocktail. The instrument employed has a relatively low background (11 cpm) and the ability to separate α from β activity on the basis of pulse shapes. The ^{234}Th + $^{234\text{m}}\text{Pa}$ counting efficiency is 50% over the counting window employed. The limit of detection, using the above parameters, a 20 litre sample, and a 400-min count, is found to be 0.04 dpm/l. It was also demonstrated that less advanced instruments, without α/β separation, can also be used effectively.

Bacon and Anderson [42] determined ^{230}Th and ^{228}Th concentrations, in both dissolved and particulate forms, in seawater samples from the eastern equatorial Pacific. The results indicate that the thorium isotopes in the deep ocean are continuously exchanged between seawater and particle surfaces. The estimated rate of exchange is fast compared with the removal rate of the particulate matter, suggesting that the particle surfaces are nearly in equilibrium with respect to the exchange of metals with seawater.

Because of the large volumes of water that were required, an in situ sampling procedure was used. Submersible, battery powered pumping systems [43, 44] were used to force the water first through filters (62 μm mesh Nitex followed by 1.0 μm pore-size Nucleopore) then through an adsorber cartridge packed with Nitex netting that was coated with manganese dioxide to scavenge the dissolved thorium isotopes, and finally through a flow meter to record the volume of water that was filtered. Natural ^{234}Th served as the tracer for monitoring the efficiency of the adsorbed cartridges. Standard radiochemical counting techniques were used [45]. On average 4% of the ^{234}Th , 15% of the ^{228}Th , and 17% of the ^{230}Th were found in the particulate form, i.e., the percentage increases with increasing radioactive half-life. However, the percentages varied considerably from sample to sample and were found to be strongly dependent on total suspended matter concentration.

Traditionally, ^{234}Th has been analysed by gas proportional counting of β -particles emitted by $^{234\text{m}}\text{Pa}$, using sample volumes ranging between 20 and 100 litres, depending on detector efficiency and background [38, 46, 47]. Since the analysis requires preconcentration and purification of the sample and electrodeposition onto a planchette, a yield monitor is required – typically ^{228}Th , ^{229}Th , or ^{230}Th . The samples then require a minimum of two counts – one to determine the β activity and another to determine the α activity – and each count requires independent calibration of detection efficiency. Modern gas proportional counting instruments are capable of providing low backgrounds (~ 0.3 cpm) and extremely good accuracy and precision ($\sim 2\%$) and have been used at sea [47].

An alternative approach is γ spectrometry using HpGe γ photon detectors. This technique meets most of the requirements for ^{234}Th analysis

since no chemical manipulation of the sample is required and the detectors are sufficiently rugged to be used at sea. However, the low absolute intensity of the 63 keV γ photon emissions (3.8%), combined with the relatively low detection efficiency of γ spectroscopy systems, results in large sample volumes (300–600 litres) being required for the analysis [48, 49]. These sample sizes can be achieved through the use of in situ pumps and manganese cartridges [49] which scavenge thorium from seawater [50]. These systems avoid the problems of bottle-associated sampling artefacts, such as thorium losses to the vessel walls and particles sinking below spigots, and enable sampling of rare large particles. However, the pumping system is relatively expensive and time-consuming to use, restricting the number of depths that can be sampled simultaneously. In addition, only a simple split of particulate and dissolved fractions can be achieved, with more detailed size fractionation, such as that required for the determination of colloidal ^{234}Th , requiring an alternative method. This second point is of particular relevance with the growing realisation that (i) colloids play a critical role in both carbon cycling and trace metal scavenging, and (ii) $^{234}\text{Th}/^{238}\text{U}$ disequilibrium is a useful technique for elucidating this role [51–53].

Liquid scintillation spectrometry is a technique suitable for the analysis of both α and β emitters, with much higher detection efficiencies than either α or γ spectrometry using semiconductor detectors or gas proportional counting. For α emitters, the liquid scintillation spectrometric detection efficiency is $\sim 100\%$, while for β emitters with $E_{\text{max}} > 156 \text{ keV}$ (^{14}C), detection efficiency is $> 95\%$.

7.1.6 Bromide

Foti [54] has studied the feasibility of concentrating traces of radioactive bromide ions by passing the seawater sample through a column of inactive AgBr (to effect isotopic exchanges). The effects of column height and of flow rate, volume and/or residence time of the seawater on the extent of exchange were examined; each of these variables had a significant effect.

7.1.7 Phosphate

Flynn and Meeham [55] have described a solvent extraction phosphomolybdate method using iso-amyl-alcohol for monitoring the concentration of 32-phosphorus in sea and coastal waters near nuclear generating stations.

Benitez-Nelson and Buesseler [56] have developed a new method for the collection, purification, and measurement of natural levels of ^{32}P and ^{33}P in marine particulates, and dissolved constituents of seawater. ^{32}P and ^{33}P

activities were measured using a ultra-low-level liquid scintillation counter. Measurement by liquid scintillation counting allows, for the first time, simultaneous measurement of both ^{32}P and ^{33}P . Furthermore, ^{33}P activities are measured with high efficiency ($> 50\%$), regardless of the amount of stable phosphorus in the sample. Liquid scintillation also produces energy specific β spectra which has enabled us to identify previously unrecognised β -emitting contaminants in natural samples. In order to remove these contaminants, new methods of purification have been developed which utilise a series of precipitations and anion and cation exchange columns. Dissolved seawater samples were extracted from large volumes of seawater (> 5000 litres) using iron-impregnated polypropylene filters. On these filters, it was possible to load between 25 and 30% $\text{Fe}(\text{OH})_3$ by weight, over twice that loaded on previously utilised materials. Using these collection, purification, and liquid scintillation counting techniques, it was possible to obtain specific ^{32}P and ^{33}P activities with less than 10% error (2a) in rainwater and 20% error (2a) in seawater.

7.2

Fallout Products and Nuclear Plant Emissions

7.2.1

Americium and Plutonium

Livingston and Cochran [50] collected large seawater samples by using a cable-supported electrical pumping system for subsequent determination of thorium, americium, and plutonium isotopes. Particles were removed by filtration and actinides were collected by absorption on manganese dioxide-coated filters. The samples were then analysed by standard radiochemical and a spectrometric techniques.

Schell et al. [57] have described a sorption technique for sampling plutonium and americium, from up to 4000 litres of water in 3 h. Battelle large-volume water samples consisting of $0.3\ \mu\text{m}$ Millipore filters and sorption beds of aluminium oxide were used. Particulate, soluble, and presumed colloidal fractions are collected and analysed separately. The technique has been used in fresh and saline waters, and has proved to be reliable and comparatively simple.

7.2.2

$^{137}\text{Caesium}$

Dutton [58] has described a procedure for the determination of $^{137}\text{caesium}$ in water. This procedure comprises a simple one-step separation of the radio-caesium from the sample using ammonium dodecamolybdophosphate or potassium cobaltihexacyanoferrate; $^{137}\text{caesium}$ and $^{134}\text{caesium}$ are measured

by γ -ray counting of the dried adsorbent with a NaI(Tl) crystal coupled to a γ -ray spectrometer. Levels of $^{137}\text{Caesium}$ activity down to about 1 pCi per litre can be determined in seawater and lake, rain, and river waters without sophisticated chemical processing.

A further method for the determination of caesium isotopes in saline waters [60] is based on the high selectivity of ammonium cobalt ferrocyanide for caesium. The sample (100–500 ml) is made 1 M in hydrochloric acid and 0.5 M in hydrofluoric acid, then stirred for 5–10 min with 100 mg of the ferrocyanide. When the material has settled, it is collected on a filter (pore size 0.45 μm), washed with water, drained dried under an infrared lamp, covered with plastic film and β -counted for $^{137}\text{Caesium}$. If $^{131}\text{Caesium}$ is also present, the γ -spectrometric method of Yamamoto [61] must be used. Caesium can be determined at levels down to 10 pCi/l.

Mason [62] has described a rapid method for the separation of $^{137}\text{Caesium}$ from a large volume of seawater. In this procedure the sample (50 litres) is adjusted to pH 1 with nitric acid, and ammonium nitrate (100 g) and caesium chloride (30 mg) added as carrier. A slurry is prepared of ammonium molybdophosphate (7.5 g) and Gooch-crucible asbestos (715 g) with 0.01 M ammonium nitrate and deposited by centrifugation on a filter paper fitted in the basket of a continuous-flow centrifuge. The sample is centrifuged at 600–3000 rpm and the deposit washed on the filter with 1 M ammonium nitrate (60–70 ml) and 0.01 M nitric acid (30–40 ml). The caesium collected on the filter is then prepared for counting by the method of Morgan and Arkell [63]. With this method the caesium can be extracted in less than an hour.

Krosshaven et al. [64] used scintillation spectrometry employing germanium detectors to measure $^{137}\text{Caesium}$ and $^{90}\text{Strontium}$ in coastal seawaters.

Aleksan'yan [65] has discussed a method for determining $^{90}\text{Strontium}$ and $^{137}\text{Caesium}$ in seawater or river water involving isolation of the radionuclides, in the presence of strontium and caesium carriers, by precipitation as the carbonate and ferrocyanide respectively. The carbonate is dissolved in 0.5 N hydrochloric acid and the strontium in this solution is precipitated as oxalate, the precipitation ignited and a solution of the product in 2 N hydrochloric acid is set aside for accumulation of $^{90}\text{Yttrium}$; this is precipitated as hydroxide (and again as oxalate) for β -counting.

The ferrocyanide precipitate containing $^{137}\text{Caesium}$ is ignited at $< 400^\circ\text{C}$, the residue is extracted with boiling water, then evaporated and a solution of the residue in acetic acid is treated to precipitate caesium (as $\text{Cs}_3\text{Bi}_2\text{I}_9$) for β -counting.

Huang et al. [66] removed $^{137}\text{Caesium}$ from 4 litre samples of seawater by adsorption onto a filter coated with copper (II) and then determined it by with 47% recovery by γ -ray spectrometry.

Riel [67] studied in situ extraction combined with γ -ray spectrometry in an underwater probe for the determination caesium and chromium in seawater.

7.2.3

⁶⁰Cobalt

Hiraide et al. [68] used continuous flow coprecipitation-floatation for the radiochemical separation of ⁶⁰cobalt from seawater. The ⁶⁰cobalt activity was measured by liquid scintillation counting with greater than 90% yield and a detection limit of 5 fCi/l seawater.

Tseng et al. [69] determined ⁶⁰cobalt in seawater by successive extractions with tris(pyrrolidine dithiocarbamate) bismuth (III) and ammonium pyrrolidine dithiocarbamate and back-extraction with bismuth (III). Filtered seawater adjusted to pH 1.0–1.5 was extracted with chloroform and 0.01 M tris(pyrrolidine dithiocarbamate) bismuth (III) to remove certain metallic contaminants. The aqueous residue was adjusted to pH 4.5 and re-extracted with chloroform and 2% ammonium pyrrolidine thiocarbamate, to remove cobalt. Back-extraction with bismuth (III) solution removed further trace elements. The organic phase was dried under infrared and counted in a germanium/lithium detector coupled to a 4096 channel pulse height analyser. Indicated recovery was 96%, and the analysis time excluding counting was 50-min per sample.

7.2.4

⁵⁵Iron

Testa and Staccioli [70] used Microthene-710 (microporous polyethylene) as a support material for bis-(2-ethylhexyl) hydrogen phosphate in the determination of ⁵⁵iron in environmental samples.

7.2.5

⁵⁴Manganese

⁵⁴Manganese has also been determined by a method [71] using coprecipitation with ferric hydroxide. The precipitate is boiled with hydrogen peroxide and the iron is removed by extraction with isobutyl methyl ketone. Zinc is separated on an anion exchange column and the manganese is separated by oxidising it to permanganate in the presence of tetraphenylarsonium chloride and extracting the resulting complex with chloroform prior to a spectrophotometric finish. Both ⁶⁵zinc and ⁵⁴manganese are counted with a 512-channel analyser with a well-type NaI(Tl) crystal (7.6 × 7.6 cm). Recoveries of known amounts of ⁶⁵zinc and ⁵⁴manganese were between 74% and 84% and between 69% and 74%, respectively.

Flynn [72] has described a solvent extraction procedure for the determination of ⁵⁴manganese in seawater in which the sample with bismuth, cerium, and chromium carriers, is extracted with a heptane solution of bis(2-ethylhexyl) phosphate and the manganese back-extracted with 1 M hydrochloric acid. After

oxidation with nitric acid and potassium chlorate, manganese is determined spectrophotometrically as permanganate ion.

7.2.6

²³⁷Neptunium

May et al. [73] used neutron activation analysis to determine ²³⁷neptunium in waste waters. The determination used the ²³⁷Np(*n, γ*)²³⁸Np reaction. The detection limit was 5×10^{-6} μg of ²³⁷neptunium, which corresponds to 2.5×10^{-6} μg/kg for 200 ml seawater samples.

Holm et al. [74] used α spectrometry for the determination of ²³⁷neptunium in seawater. The actinides are preconcentrated from a large seawater sample by hydroxide precipitation. The neptunium was isolated by ion exchange, fluoride precipitation, and extraction with TTA. ²³⁸Neptunium or ²³⁵neptunium was used to determine the radiochemical yield.

7.2.7

Plutonium

The plutonium concentration in marine samples is principally due to environmental pollution caused by fallout from nuclear explosions and is generally at very low levels [75]. Environmental samples also contain microtraces of natural α emitters (uranium, thorium, and their decay products) which complicate the plutonium determinations [76]. Methods for the determination of plutonium in marine samples must therefore be very sensitive and selective. The methods reported for the chemical separation of plutonium are based on ion exchange resins [76–80] or liquid–liquid extraction with tertiary amines [81], organophosphorus compounds [82, 83], and ketones [84, 85].

Wong [77] has described a method for the radiochemical determination of plutonium in seawater, sediments, and marine organisms. This procedure permits routine determinations of ²³⁹plutonium activities (dpm) down to 0.004 dpm per 100 litres of seawater (50 litre sample), 0.02 dpm per kg sediments (100 g samples), and 0.002 dpm per kg of organisms (1 kg sample). The plutonium is separated from seawater by coprecipitation with ferric hydroxide and from dried sediments or ashed organisms by leaching with nitric acid and hydrochloric acid [86]. After further treatment and purification by ion exchange, the plutonium is electro-deposited onto stainless steel disks for counting and resolution of the activity by α-spectrometry. For 30 samples the average deviation was generally well within the 1SD counting error. For seawater the average recovery was $52 \pm 18\%$ and for sediments and organisms it was $63 \pm 20\%$. The most serious interference is from ²²⁸thorium, which is present in most samples and is also a decay product of the ²³⁶plutonium tracer.

Livingstone et al. [87] carried out double tracer studies to optimise conditions for the radiochemical separation of plutonium from large volumes of seawater.

In this procedure ^{242}Pu is added to determine the overall recovery of plutonium from the sample, and the recovery of ^{242}Pu at any point in the procedure is measured by the addition of a similar amount of ^{236}Pu at that point, the final recovery of ^{236}Pu being used to calculate the recovery of ^{242}Pu at the time of the addition of ^{236}Pu . Experience with this double-tracer experiment has permitted improvement in the ability to recover plutonium from 50 litre samples for α -spectrophotometric analysis of ^{239}Pu , ^{240}Pu , and sometimes ^{238}Pu .

Anderson and Fleer [88] determined the natural actinides ^{237}Ac , ^{228}Th , ^{230}Th , ^{232}Th , ^{234}Th , ^{231}Pa , ^{238}U and ^{234}U , and the α -emitting plutonium isotopes in samples of suspended marine particulate material and sediments. Analysis involves total dissolution of the samples to allow equilibration of the natural isotopes with added isotope yield monitors followed by coprecipitation of hydrolysable metals at pH 7 with natural iron and aluminium acting as carriers to remove alkali and alkaline earth metals. Final purification is by ion exchange chromatography (Dowex AG1-X3) and solvent extraction for palladium. Overall chemical yields generally range from 50% to 90%. The method has been successfully interfaced with methods to include the determination of fallout elements of ^{55}Fe , ^{137}Cs , ^{90}Sr and ^{241}Am on the same samples.

Testa and Staccioli [70] have pointed out that Microthene-710 (a microporous polyethylene) as a support material for triphenylphosphine oxide in cyclohexane medium has a potential application for the determination of plutonium in fallout samples.

Hirose and Sugimura [89] investigated the speciation of plutonium in seawater using adsorption of plutonium (IV)-xylenol orange and plutonium-arsenazo (III) complexes on the macroreticular synthetic resin XAD-2. Xylenol orange was selective for plutonium (IV) and arsenazo (III) for total plutonium. Plutonium levels were determined by α -ray spectrometry.

Kim et al. [116] determined plutonium isotopes in seawater by an online sequential injection technique with sector field ICP-MS.

Delle Site et al. [90] have used extraction chromatography to determine plutonium in seawater sediments and marine organisms. These workers used double extraction chromatography with Microthene-210 (microporous polyethylene) supporting tri-octylphosphine oxide, a technique that has been used previously to isolate plutonium from other biological and environmental samples [91]. ^{236}Pu and ^{242}Pu were tested as the internal standards to determine the overall plutonium recovery, but ^{242}Pu was generally preferred because ^{236}Pu has a shorter half-life and an α -emission (5.77 MeV) which interferes strongly with the 5.68 MeV (95%) α -line of ^{224}Ra , the daughter of ^{228}Th . However, the 5.42 MeV-lines of ^{228}Th interfere with those of ^{238}Pu (5.50 MeV) and so a complete purification from thorium isotopes is required.

Plutonium sources were counted by an α -spectrometer with good resolution, background, and counting yield. The counting apparatus used had a resolution of 40 keV. The mean (\pm sd) background value was 0.0004 ± 0.0003 cpm in the ^{239}Pu plutonium and ^{240}Pu plutonium energy range and 0.0001 ± 0.0001 cpm in the ^{238}Pu plutonium energy range. The mean (iso) counting yield, obtained with ^{239}Pu plutonium, ^{240}Pu plutonium reference sources counted in the same geometry, was found to be $25.08 \pm 0.72\%$.

To determine the overall recovery obtained by this procedure (chemical recovery and electrodeposition yield) a known activity of ^{242}Pu plutonium was added to the different samples; the plutonium sources were counted by α -spectrometry for 3000 minutes and the percentage overall recovery was calculated from the area of ^{242}Pu plutonium peak. The percentage overall recovery for 3-litre samples of seawater was $63 \pm 10\%$. Owing to the very low activity of the samples, the determination of ^{239}Pu plutonium, ^{240}Pu plutonium, and ^{238}Pu plutonium in the reagents is very important in calculating the net activity of the radionuclides.

The method proposed was checked by analysing some seawater reference samples prepared by the IAEA Marine Radioactivity Laboratory (Monaco) for intercomparison programmes. The values reported by IAEA and the experimental values obtained by Delle Site et al. [90] were in good agreement.

Buesseler and Halverson [92] have described a thermal ionisation mass spectrometric technique for the determination of ^{239}Pu plutonium and ^{240}Pu plutonium in seawater. The mass spectrometric technique was more sensitive than α spectrometry by more than order of magnitude.

7.2.8

^{106}Ru Ruthenium and Osmium

Kiba et al. [93] has described a method for determining this element in marine sediments. The sample is heated with a mixture of potassium dichromate and condensed phosphoric acid (prepared by dehydrating phosphoric acid at 300°C). The ruthenium is distilled off as RuO_4 , collected in 6 M hydrochloric acid-ethanol and determined spectrophotometrically (with thiourea) or radiometrically. Osmium is separated by prior distillation with a mixture of condensed phosphoric acid and $\text{Ce}(\text{SO}_4)_2$. In the separation of ruthenium-osmium mixtures recovery of each element ranged from 96.8 to 105.0%.

7.2.9

^{90}Sr Strontium

Silant'ev et al. [94] have described a procedure for the determination of ^{90}Sr strontium in small volumes of seawater. This method is based on the determination of the daughter isotope ^{90}Y yttrium. The sample is acidified with

hydrochloric acid, heated and, after addition of iron, interfering isotopes are separated by double coprecipitation with ferric hydroxide. The filtrate is acidified with hydrochloric acid, yttrium carrier added, the solution set aside for 14 days for ingrowth of $^{90}\text{yttrium}$, and $\text{Y}(\text{OH})_3$ precipitated from the hot solution with carbon dioxide free aqueous ammonia. Then $\text{Y}(\text{OH})_3$ is reprecipitated from a small volume in the presence of hold-back carrier for strontium, the precipitate dissolved in the minimum amount of nitric acid, the solution heated and yttrium oxalate precipitated by adding precipitated oxalic acid solution. The precipitate is collected and ignited at $800\text{--}850\text{ }^\circ\text{C}$ to Y_2O_3 . The cooled residue is weighed to determine the chemical yield, then sealed in a polyethylene bag and the radioactivity of the saturated yttrium measured on a low-background β -spectrometer. If the short-lived nuclides $^{140}\text{barium}$ and $^{140}\text{lanthanum}$ are thought to be present in the seawater sample, lanthanum carrier is introduced after the first $\text{Y}(\text{OH})_3$ separation, and the system is freed from $^{140}\text{lanthanum}$ by precipitation of the double sulfate of lanthanum and potassium from a solution saturated with potassium sulfate.

Gordon and Larson [95] used photon activation analysis to determine $^{87}\text{strontium}$ in seawater. Samples (2 ml, acidified to pH 1.67 or 2.54 for storage) were filtered and freeze-dried. The residues, together with strontium standards, were wrapped in polyethylene and aluminium foil and irradiated in a 30 MeV bremsstrahlung flux of γ -radiation. After irradiation, the samples were dissolved in 50 ml of acidified water and $^{87m}\text{strontium}$ was separated by precipitation as strontium carbonate for counting (γ -ray spectrometer, Ge(Li) detector and multichannel pulse-height analyser). The standard deviation at the 7 ppm strontium level was ± 0.47 .

Pinones determined $^{90}\text{strontium}$ in seawater [96]. The seawater sample is filtered and a known amount of strontium nitrate is added to the filter as a carrier. Precipitation of the radiogenic elements, followed by addition of fuming nitric acid, separates strontium nitrate from the radiogenic elements. The $^{90}\text{strontium}$ is measured by the change in activity of the radiogenic daughter, $^{90}\text{yttrium}$.

Chassery et al. [97] studied the $^{87}\text{Sr}/^{86}\text{Br}$ composition in marine sediments, observing excellent agreement between results obtained by ICP-MS and thermal ionisation mass spectrometry. Low level α -spectrometry with lithium drifted germanium detectors has been used to determine $^{90}\text{strontium}$ in seawater [59].

7.2.10

Uranium

Spencer [98] has reviewed the determination of uranium in seawater.

Bertine et al. [99] have discussed the determination of uranium in deep sea sediments and water utilising the fission track technique. In this technique a weighed aliquot (50–100 mg) of the powdered sample is made into a pel-

let with sufficient cellulose (as binder). The pellet is placed in a high-purity aluminium capsule and covered by polycarbonate plastic film (Lexan, 10 μm thick).

Adsorbing colloid flotation has been used to separate uranium from seawater [101].

To the filtered seawater (500 ml; about 1.5 μg U) is added 0.05 M ferric chloride (3 ml), the pH is adjusted to 6.7 ± 0.1 and the uranium present as $(\text{UO}_2(\text{CO}_3)_3)^{4-}$ is adsorbed on the colloidal ferric hydroxide which is floated to the surface as a stable froth by the addition of 0.05% ethanolic sodium dodecyl sulfate (2 ml) with an air-flow (about 10 ml min^{-1}) through the mixture for 5 min. The froth is removed and dissolved in 12 M hydrochloric acid-16 M nitric acid (4:1) and the uranium is salted out with a solution of calcium nitrate containing EDTA, and determined spectrophotometrically at 555 nm by a modification of a Rhodamine B method. The average recovery of uranium is 82%; co-adsorbed WO_4^{2-} and MoO_4^{2-} do not interfere.

Adsorbing colloid flotation has also been used by Williams and Gillam [102]. The fusion track method has also been used by Hashimoto [100]. In this method the uranium is first coprecipitated with aluminium phosphate [103], the precipitate is dissolved in dilute nitric acid and an aliquot of the solution is transferred to a silica ampoule into which small pieces of muscovite are inserted before sealing. The uranium is then determined by measuring the density of fission tracks formed on the muscovite during irradiation of the ampoule for 15 min at 80 $^\circ\text{C}$ in a neutron reactor. The muscovite is etched with hydrofluoric acid for 1 h before the photomicrography; the density is referred to that obtained with standard solution of uranium. There is no interference from thorium, and no chemical separations are required. An average concentration of $3-40 \pm 0.12$ μg uranium per litre was obtained, in good agreement with the normally accepted value.

Leung et al. [104] and Kim and Zeitlin [105] described a method for the separation and determination of uranium in seawater. Thoric hydroxide ($\text{Th}(\text{OH})_4$) was used as a collector. The final uranium concentration was measured via the fluorescence (at 575 nm) of its Rhodamine B complex. The detection limit was about 200 $\mu\text{g/l}$.

Korkisch and Koch [106, 107] determined low concentrations of uranium in seawater by extraction and ion exchange in a solvent system containing trioctyl phosphine oxide. Uranium is extracted from the sample solution (adjusted to be 1 M in hydrochloric acid and to contain 0.5% of ascorbic acid) with 0.1 M trioctylphosphine oxide in ethyl ether. The extract is treated with sufficient 2-methoxyethanol and 12 M hydrochloric acid to make the solvent composition 2-methoxyethanol-0.1 M ethereal trioctylphosphine acid-12 M hydrochloric acid (9:10:1); this solution is applied to a column of Dowex 1-X8 resin (Cl^- form). Excess of trioctylphosphine oxide is removed by washing the column with the same solvent mixture. Molybdenum is removed by elution with 2-methoxyethanol-30% aqueous hydrogen peroxide-12 M hydrochloric

acid (18:1:1); the column is washed with 6 M hydrochloric acid and uranium is eluted with molar hydrochloric acid and determined fluorometrically or spectrophotometrically with ammonium thiocyanate. Large amounts of molybdenum should be removed by a preliminary extraction of the sample solution (made 6 M in hydrochloric acid) with ether.

Spectrophotometric analysis following extraction with Aliquot 336 has been used to determine uranium in seawater [108]. Kim and Burnett [109] used X-ray spectrometry to determine the uranium series nucleides including ^{238}U , ^{226}Ra and ^{210}Pb in marine phosphorites.

Bowie and Clayton [110] used γ -ray spectrometry to determine uranium, thorium, and potassium in sea bottom surveys.

Chen et al. [111] determined ^{238}U , ^{234}U and ^{232}Th in seawater by isotope dilution mass spectrometry. Uranium measurements were made by using a $^{233}\text{U}/^{236}\text{U}$ double spike to correct for instrumental fractionation. The $^{234}\text{U}/^{238}\text{U}$ ratio could be measured routinely to $\pm 5\%$ for $0.03\ \mu\text{g}$ of total uranium in a 1-h data acquisition time, which is considerably shorter than α -counting. The ^{232}Th is measured to $\pm 20\%$ for $0.001\ \mu\text{g}$ of ^{232}Th .

7.2.11

Miscellaneous

Spencer and Brewer [112] have reviewed the determination of radionuclides in seawater and discuss sampling and storage methods together with tables of radionuclides that have been determined in the oceans.

Becker and Dietze [113] used a micro mist nebuliser with ICP high resolution mass spectrometry to determine sub-picogram/l levels radionuclides in seawater.

References

1. Lin B, Wu H, Cai Z (1987) *Yuanzineng Kexue Jishu* 21:447
2. Skwarzek B, Bojanowski R (1988) *Mar Biol* 97:30
3. Shannon LV, Orren MJ (1970) *Anal Chim Acta* 52:166
4. Nozaki Y, Tsunogai S (1973) *Anal Chim Acta* 64:209
5. Cowen JP, Hodge VF, Folsom TR (1977) *Anal Chem* 49:494
6. Tsunogai S, Nozaki Y (1971) *Geochem J* 5:165
7. Shannon LV, Cherry RD, Orren MJ (1970) *Geochim Cosmochim Acta* 34:701
8. Hodge VF, Hoffman FL, Folsom TR (1974) *Health Physics* 27:29
9. Folsom TR, Hodge VR (1975) *Mar Sci Commun* 1:213
10. Folsom TR, Hodge VF, Gurney M (1975) *Mar Sci Commun* 1:39
11. Goldberg ED, Koide M, Hodge VF (1976) Scripps Institution of Oceanography, La Jolla, CA, USA
12. Flynn A (1970) *Anal Abstr* 18:1624
13. Reid DF, Key RM, Schink DR (1979) *Earth Planet Sci Lett* 43:223

14. Orr JC (1988) *J Geophys Res C:Oceans* **93**:8265
15. Burnett W, Tai W-C (1992) *Anal Chem* **64**:1691
16. Cohen AS, O'Nions RK *Anal Chem* **63**:2705
17. Bettoli MG, Cantelli L, Queirazza G, Roveri M, Tositti L, Tubertini O, Valcher S (1996) *Int J Environ Anal Chem* **63**:29
18. Perkins RW (1969) Report of The Atomic Energy Commission, US, BNWL 1051 (Pt 2) p 23-27
19. Moore WS, Reid DF (1973) *J Geophys Res* **78**:8880
20. Moore WS (1976) *Deep-Sea Res* **23**:647
21. US Environmental Protection Agency (1975) Radiochemical Methodology for Drinking Water Regulations EPA 600/4-75-005
22. Ku TL, Huh CA, Chen PS (1980) *Earth Planet Sci Lett* **49**:293
23. Chung Y (1980) *Earth Planet Sci Lett* **49**:319
24. Moore WS (1982) *Estuar Coast Shelf Sci* **12**:713
25. Michel J, Moore WS, King PT (1981) *Anal Chem* **53**:1885
26. US Environmental Protection Agency (1976) National Interim Primary Drinking Water Regulations EPA-57019-79-003
27. Key RM, Brewer RL, Stockwell JH, Guinasso NL, Schink RD (1979) *Mar Chem* **7**:251
28. Broecker WS (1965) An application of natural radon to problems in oceanic circulations. In: Proceedings of the Symposium on Diffusion in the Oceans and Fresh Waters. Lamont Geological Observatory, New York, pp 116-145
29. Colley S, Thomson J (1994) *Sci Total Environ* **155**:273
30. Baskaran M, Murphy DJ, Santschi DPH, Orr JC, Sclink DR (1993) *Deep-Sea Res* **40**:849
31. Chen Q, Dahlgaard H, Nielson SP (1994) *Anal Chim Acta* **285**:177
32. Ballestra S, Bara G, Holm E, Lopez J (1987) *J Radioanal Nucl Chem* **175**:51
33. Uiomoshima N, Sayad M, Takashima Y (1993) *Radiochim Acta* **63**:73
34. Buessler KO, Bacon MP, Cochran JK, Livingston HD (1992) *Deep-Sea Res* **39**:1115
35. Coale KH, Bruland KW (1985) *Limnol Oceanogr* **30**:22
36. Schmidt S, Nival P, Reyss J-L, Baker M, Buat-Menard P (1992) *Oceanologica Acta* **15**:227
37. Huh C-A, Ku T-L, Luo S, Landry MR, Williams PM (1993) *Earth Planet Sci Lett* **116**:155
38. Kershaw P, Young A (1988) *J Environ Radioactivity* **6**:1
39. Guo L, Santschi PH, Baskaran M, Zindler A (1995) *Earth Planet Sci Lett* **133**:117
40. Moran SR, Hoff JA, Buessler KO, Edwards RL (1995) *Geophys Res Lett* **22**:2589
41. Pates JM, Cook GT, Mackenzie AB, Anderson R, Bury SJ (1996) *Anal Chem* **68**:3783
42. Bacon MP, Anderson RF (1981) Trace metals in sea water. In: Wong CS et al. (eds) Proceedings of a NATO advanced research institute on trace metals in seawater, Sicily, Italy. Plenum Press, New York, p 368
43. Spencer DW, Sachs PL (1970) *Mar Geol* **9**:117
44. Krishnaswami S, Lal D, Somayajulu BLK, Weiss RF, Craig H (1976) *Earth Planet Sci Lett* **32**:420
45. Anderson RF (1981) The marine geochemistry of thorium and protactinium. PhD dissertation. Massachusetts Institute of Technology/Woods Hole Oceanographic Institution WH01-81-1
46. Coale KH, Bruland KW (1985) *Limnol Oceanogr* **32**:189
47. Buessler KO, Michaels AF, Siegal DA, Knap AH (1994) *Global Biochem Cy* **8**:179
48. Aller RC, De Master DJ (1984) *Earth Planet Sci Lett* **67**:308
49. Buessler KO, Cochran JK, Becou MP, Livingston HD, Casso SA, Hirschberg D, Hartman MC, Flees AP (1992) *Deep-Sea Res* **39**:1103
50. Livingston HD, Cochran JK (1987) *J Radioanal Nucl Chem Ar* **115**:299
51. Moran SB, Buessler KO (1993) *J Mar Res* **51**:893

52. Niven SHE, Kepkay PE, Boraie A (1995) *Deep-Sea Res Part II* **42**:257
53. Huh CA, Prael FG (1995) *Limnol Oceanogr* **40**:528
54. Foti SC (1971) Report Atomic Energy Commission USA AD734384
55. Flynn WW, Meehan W (1973) *Anal Chim Acta* **63**:483
56. Benitez-Nelson C, Buessler KO (1998) *Anal Chem* **70**:64
57. Schell WR, Nevissi A, Huntamer D (1978) *Mar Chem* **6**:143
58. Dutton JWR (1970) Report of the Fisheries and Radiobiological Laboratory FRL 6. Ministry of Agriculture, Fish and Food, UK
59. Lewis SR, Shafir HN (1971) *Nucl Instrum Methods* **93**:317
60. Janzer VJ (1973) *Journal of Research of the UK Geological Survey* **1**:113
61. Yamamoto O (1967) *Anal Abstr* **14**:6669
62. Mason WJ (1974) *Radiochem Radioanal Lett* **16**:237
63. Morgan A, Arkell O (1963) *Health Physics* **9**:857
64. Krosshaven M, Skipperud L, Lien HN, Salbu B (1996) *Health Physics* **71**:326
65. Aleksan'yan OM (1972) *Gidrokhim Mater* **53**:163 [Reference Zhur Khim IGGD 1972 (13) Abstract No.13G146, in Russian]
66. Huang C-Y, Lee J-D, Tseng C-L, Lo J-M (1994) *Anal Chim Acta* **294**:121
67. Riel G (1995) In: King SE (ed) Proceedings of the workshop on monitoring nuclear contamination in arctic seas. Naval Research Laboratory, Washington, DC, USA
68. Hiraide M, Sakurai K, Mizuike A (1984) *Anal Chem* **56**:2851
69. Tseng C-L, Hsieh YS, Yong MH (1985) *J Radioanal Nucl Chem Lett* **95**:359
70. Testa C, Stacciolo L (1972) *Analyst* **97**:527
71. Stah SM, Rao SR (1972) *Current Science (Bombay)* **41**:659
72. Flynn WW (1973) *Anal Chim Acta* **67**:129
73. May S, Engelmann C, Pinte G (1987) *J Radioanal Nucl Chem* **113**:343
74. Holm E, Aarron A, Ballestra S (1987) *J Radioanal Nucl Chem* **115**:5
75. Comar CL (1976) Plutonium: Facts and Interferences. EPRI EA-43-SR
76. Livingston HD, Mann DR, Bowen VT (1975) Analytical methods in oceanography. In: *Advances in chemistry*, ser 147. ACS, Washington, DC, p 124
77. Wong KM (1971) *Anal Chim Acta* **56**:355
78. Pillai KC, Smith RC, Folsom TR (1964) *Nature* **203**:568
79. Ballestra S, Holm E, Fukai R (1978) Presented at the symposium on the determination of radionuclides in environmental and biological materials. Central Electricity Generating Board, London, UK
80. Holm E, Fukai R (1977) *Talanta* **24**:659
81. Sakanou M, Nakamura M, Imai T (1971) Rapid methods for measuring radioactivity in the environment. In: Proceedings of the symposium, Neuherberg. IAEA, Vienna, Austria, p 171
82. Statham C, Murray CN (1976) Report of the International Committee of the Mediterranean Ocean **23**:163
83. Hampson BL, Tennant D (1973) *Analyst* **98**:873
84. Levine H, Lamanna A (1965) *Health Physics* **11**:117
85. Aakrog A (1975) Reference methods of marine radioactivity studies II. Technical report services no. 169. IAEA, Vienna, Austria
86. Chu A (1972) *Anal Abstr* **22**:427
87. Livingston HD, Mann DR, Bowen UJ (1972) Report of the Atomic Energy Commission US COO-3563-12. Woods Hole Oceanographic Institute, Massachusetts, USA
88. Anderson RF, Fleer AI (1982) *Anal Chem* **54**:1142
89. Hirose K, Sugimura YJ (1985) *J Radioanal Nucl Chem* **92**:363
90. Delle Site A, Marchionni V, Testa C (1980) *Anal Chim Acta* **117**:217

91. Testa C, Delle Site A (1976) *J Radioanal Chem* **34**:121
92. Buessler KO, Halverson JE (1987) *J Environ Radioactiv* **5**:425
93. Kiba T, Terada K, Suzuki K (1972) *Talanta* **19**:451
94. Silant'ev AN, Chumichev VB, Vakulovskii SM (1970) *Trudy Inst Eksp Met Glav Uprav Gidromet, Sluzhny Sov Minist SSSR* **15** (2) [Ref: (1971) *Zhur Khim* **19GD** (1) Abstr. No. 1 G209]
95. Gordon CM, Larson RE (1970) *Radiochem Radioanal Lett* **5**:369
96. Pinones O (1986) *Nucleotechnica* **6**:55
97. Chassery S, Grousset FE, Lavaux G, Quetel CR (1998) *Fresen J Anal Chem* **360**:230
98. Spencer R (1968) *Talanta* **15**:1307
99. Bertine KK, Chan LH, Turekian KK (1970) *Geochim Cosmochim Acta* **34**:641
100. Hashimoto T (1971) *Anal Chim Acta* **56**:347
101. Kim YS, Zeitlin H (1971) *Anal Chem* **43**:1390
102. Williams WJ, Gillam AH (1979) *Analyst* **103**:1239
103. Smith J, Grimaldi O (1957) *Bulletin of the US Geological Survey* **1006**:125
104. Leung G, Kim YS, Zeitlin H (1972) *Anal Chim Acta* **60**:229
105. Kim YS, Zeitlin H (1972) *Anal Abstr* **22**:4571
106. Korkisch J, Koch W (1973) *Mikrochim Acta* **1**:157
107. Korkisch J (1972) *Mikrochim Acta* **687**
108. Barbano PG, Rigoli L (1978) *Anal Chim Acta* **96**:199
109. Kim KH, Burnett WC (1983) *Anal Chem* **55**:796
110. Bowie SHU, Clayton CG (1972) *Translations of the Institution of Minerals and Metals B* **81**:215
111. Chen JH, Edwards RL, Wasserburg GJ (1986) *Earth Planet Sci Lett* **80**:241
112. Spencer W, Brewer PG (1970) *Crit Rev Solid State Sci. Ocenographic Institute, Woods Hole, Massachusetts, USA* **1**:409
113. Becker JS, Dietze H-J (1999) *J Anal Atom Spectros* **14**:1493
114. Keith-Roach M, Stuerup S, Oughton DH, Dahlgaard H (2002) *Analyst* **127**:70
115. Biggin CD, Cook CT, Mackenzie AB, Pates JM (2002) *Anal Chem* **74**:671
116. Kim C-S, Kim C-K, Lee KJ (2002) *Anal Chem* **74**:3824

8 Sample Preparation Prior to Analysis for Organics

Methods of identifying and measuring organic compounds have improved greatly in the past few decades. The development of the various kinds of instrumental chromatography has made identification of components of complex organic mixtures a matter of routine laboratory procedure, and the coupling of the gas chromatograph to the mass spectrometer has produced a tool of almost unbelievable power and versatility, one that will, in the long run, enable us to unravel even the most complex mixtures.

The concentration of organic materials in seawater is too low to merit direct utilization of many of the modern analytical instruments; concentration by a factor of a hundred or more is necessary in many instances. Furthermore, the water and inorganic salts interfere with many of the analytical procedures. Separation of the organic components from seawater therefore accomplishes two purposes; it removes interfering substances, and at the same time concentrates enough organic matter to make analysis possible. It is not surprising that considerable effort has been put into methods of separation and concentration.

Even after the organic compounds have been concentrated and separated from seawater, the resulting mixture may be too complex for the analytical method we wish to employ. If we have collected a large enough sample of organic material, we may then resort to any of a number of fractionation schemes, based perhaps on functional groups or molecular weights, in order to simplify the mixtures to the point where analysis could be relatively straightforward. Alternatively, if we wish to measure only one compound or class of compounds, we may try to design a concentration method which will be specific for the compounds of interest, thus achieving concentration and fractionation in one step. Both of these approaches have been followed with some success.

There is an extensive literature on concentration, separation, and fractionation methods. References [1–5] give general reviews.

The simplest approach to the collection and subdivision of organic materials in seawater is to use some physical or chemical means of removing one fraction from solution or suspension. The techniques vary, from simple filtration to collect particulate matter, to chemical methods, such as solvent extraction and coprecipitation. With each of these methods, the analyst must know the efficiency of collection and exactly which fraction is being collected. Very often the fraction is defined by the method of collection; two methods

that purport to collect the same fraction may in fact be sampling very different universes. Comparisons between the results of different investigators are usually difficult because we do not know whether differences in results stem from real differences in the areas or times of collection or from differences in the methods used. Intercalibration of analytical methods is generally agreed to be a good thing, once a field has become sufficiently stabilized so that certain methods are more or less recognized as "standard" methods. It is now more often being realised that the intercalation should start not with the analytical methods, but with the sampling methods, if true comparisons are to be made.

8.1

Soluble Components of Seawater

Various techniques for the concentration of organics in the soluble fraction of seawater prior to analysis are discussed below.

8.1.1

Reverse Osmosis

This technique has been applied to the concentration of organochlorine and organophosphorus insecticide [7, 8] and various ethers, glycols amines, nitriles, hydrocarbons, and chlorinated hydrocarbons. Although this work was concerned with drinking water, it is a useful technique which may have application in seawater analysis. Cellulose acetate [9], ethyl cellulose acetate [6], and crosslinked polyethyleneimine [8] have been used as semi-permeable membranes.

8.1.2

Freeze Drying

This is another technique which has applications in seawater analysis. Approximately 100% recovery of glucose and lindane at the 0.1 and 0.15 mg/l level have been obtained from water by this technique.

Pocklington [10] has separated amino acids in seawater using this technique. The first step in his concentration of free amino acids from seawater was the freeze drying of the seawater sample. To reduce interferences in the later steps of the procedure, the sea salts were packed into a chromatographic column and washed with diethyl ether to remove non-polar compounds. The diethyl ether extract, particularly from surface water samples, quite often contained coloured materials as well as other organics. If a series of solvents of graduated polarity were passed through a sea salt column, a fractionation by polarity should be obtained. With the proper choice of solvents, a form of gradient elution could be devised which would result in a continuous, rather than a batch fractionation.

8.1.3

Freezing-Out Methods

Slow freezing, with constant stirring, results in a concentration of organic materials in the solution remaining. The technique is most effective in water of low salinity. It has been applied to lake water with some success but marine applications do not seem to have been developed [9, 11–13].

8.1.4

Froth Flotation

In its passage through a water column, a bubble acts as an interface between the liquid and vapour phases, and as such collects surface-active dissolved materials as well as colloidal micelles on its surface. Thus in a well-aerated layer of water, the upper levels will become progressively enriched in surface-active materials. In the open ocean, an equilibrium undoubtedly exists between the materials carried downward by bubble injection from breaking waves and those carried upward by rising bubbles. In the laboratory, however, this effect will enrich the surface layer with organic materials.

When the concentrations of surface-active materials are high, the injection of bubbles into the solution from well below the surface may result in the formation of a foam at the surface. The foam can be as much as 200 times as concentrated in organic material as the body of the solution [14]. Natural foams of this kind can often be seen along beaches during periods of strong winds and violent wave action. Even when the surface-active materials are not present at levels high enough for foam formation, a considerable enrichment of organic material can be found in the upper part of the water column [15, 16].

8.1.5

Solvent Extraction

Solvent extraction is another attractive method for concentrating a particular fraction of the dissolved organic matter, the fraction concentrated being determined by the choice of solvent. The most obvious limitation on the method is that set by solvent choice; the solvent should have only limited solubility in water, which limits the materials removed to the less polar compounds. Another limitation is that set by contamination. The solvent used must be purified carefully, since the amounts of the various organic compounds collected from seawater will be about as large as the trace impurities in the solvents. Because of the relatively large amount of time and equipment required for the processing of each sample, these methods must be used to characterize the organic compounds at a few selected stations and depths, rather than in mass surveys. Once the separation into the organic solvent has been accomplished, any of a number of techniques of fractionation and analysis can be applied.

The first step in the solvent extraction is the actual sampling of the water column. All of the problems associated with sampling can occur in this step, and may be aggravated by the large volumes of seawater customarily employed. The cleverest approach to this problem is to avoid sampling in the normal manner altogether. Ahnoff and Josefsson [17] have described an in situ apparatus for solvent extraction. This apparatus is buoyed at the sampling depth, anywhere between the surface and 50 m, and water is pumped through a series of extraction chambers. The capacity of the unit is 50 l per 48 h. The use of an in situ pumping system on the far side of the extraction chambers eliminates the pump and hose contamination, as well as much of the contamination coming from the passage through the surface film. Since the apparatus is battery powered, the unit may be suspended from a free-floating surface buoy; no ship time is required, except for placement and recovery of the samplers. Thus while each sample may require up to 48 h to collect, a number of depths and areas may be sampled in the same time period.

Ahnoff and Josefsson [18] built a solvent extraction apparatus for river work which was later modified into their in situ extractor [17]. The unit as described in the earlier work could easily be adapted for seawater analysis. A unit based on a Teflon helix liquid-liquid extractor, some 332 feet (101.5 metres) in length, was constructed by Wu and Suffet [19]. The extractor was optimized for the removal of organophosphorus compounds, specifically pesticides, with an efficiency of around 80%. For some compounds, these continuous extraction methods should be the methods of choice and should be explored.

The conventional approach to solvent extraction is the batch method. Early work with this method was hampered by the low concentration of the compounds present and the relative insensitivity of the methods of characterization. Thus lipids and hydrocarbons have been separated from seawater by extraction with petroleum ether and ethyl acetate. The fractionation techniques include column and thin-layer chromatography with final characterisation by thin-layer chromatography, infrared, and ultra-violet spectroscopy and gas chromatography. Of these techniques, only gas chromatography is really useful at levels of organic matter present in seawater. With techniques available today such as glass capillary gas chromatography and mass spectrometry, much more information could be extracted from such samples [20].

This type of separation and fractionation has been proposed by Copin and Barbier [21].

The Oil Companies International Study Group for Conservation of Clear Air and Water-Europe (Concawe) [22] have made a detailed study of the application of solvent extraction to the determination of organics in water.

Solvent extraction has proved to be most useful when applied to the concentration of particular compounds for which there exists an analytical method of great sensitivity. The major application of the method has been for the determination of hydrocarbons in seawater.

In general, solvent extraction is an excellent method for the concentration and determination of specific compounds, chiefly non-polar, in seawater [23]. Special precautions must be taken to prevent contamination from trace materials in the solvents used. In situ methods offer many advantages, not the least being the elimination of lengthy processing in the shipboard laboratory. When coupled to modern separation and detection systems, the methods may offer us the simplest and most direct approach to the measurement of certain classes of compounds. In most cases, we have little or no estimate of the efficiency of the solvent extraction techniques. Because of the great variety of compounds present in any one sample, a true efficiency of extraction may be impossible to obtain. Working efficiencies, using model compounds, may be the only approach in trying to make the analysis truly quantitative.

During the investigation of pollution in coastal seawaters, Werner and Waldichuk [24] pointed out the need for concentrating and isolating trace amounts of certain substances with a continuous solvent extractor. They constructed a modified Scheibel apparatus by changing the organic solvent cycle system.

8.1.6

Coprecipitation Techniques

Another method of segregating and removing a portion of the dissolved organic matter includes incorporation into a solid phase, which can then be removed by filtration or centrifugation. This incorporation can result either from coprecipitation with a solid phase formed in a reaction in the solution or, as discussed in the next section, from adsorption of the organic material onto a pre-existing solid phase.

The adsorption of organic matter on any surface presented to seawater has been well documented. Neihof and Loeb [25] have demonstrated this adsorbance by following the change in surface charge of newly immersed surfaces. There has even been an attempt to use this phenomenon as a means of measuring dissolved organic carbon. Chave [26] found an association between calcite and dissolved organic materials in seawater, and Meyers and Quinn [27] tried to use the effect as a method for the collection of fatty acids. As a collection technique adsorption on calcite has several advantages. The pH of the sample is not greatly altered by the addition of small amounts of calcite; the precipitate is dense and should settle quickly; and after filtration the inorganic support can be removed by acidification. Unfortunately, the recovery of added fatty acids was inefficient; of the order of 18%. Meyers and Quinn [28] achieved a somewhat greater efficiency of collection of fatty acids with clays, but the insolubility of the clays nullified one of the advantages of this concentration technique.

The precipitant most commonly used for the collection of organics has been what is loosely called "ferric hydroxide". It is formed by the in situ formation

of hydrated ferric oxides, usually by the addition of ferrous iron, followed by potassium hydroxide. The technique was first used for the precipitation of organic matter from an aged algal culture [29]. They recovered 79–95% of the ^{14}C -labelled material from such cultures. Williams and Zirino [30] measuring efficiencies of removal of dissolved organic carbon, found that such scavenging collected between 38% and 43% of the organic carbon measurable by wet oxidation with persulfate. Chapman and Rae [31] examined the effect of this precipitation on specific compounds. They found coprecipitation to be more complete with copper hydroxides, but still far from satisfactory. Only certain compounds were removed effectively by this treatment and the efficiency of removal varied with the water type and the organic compound involved.

A limited amount of work has been carried out using zirconium phosphates, compounds with well-defined coagulation and adsorption properties. The efficiency of coprecipitation was about 70% for free amino acids and albumin.

These methods may prove useful in the qualitative analysis of organic compounds, once the selectivities of the precipitants are understood. The metallic oxides suffer from the disadvantage of producing a precipitate which is difficult to filter, while calcite and zirconium phosphates produce relatively well-mannered precipitates. Even when the efficiencies of collection of various model compounds in seawater is known, the immense variety of organic compounds in seawater will keep this technique largely qualitative.

8.1.7

Adsorption Techniques

Coprecipitation techniques, as discussed in the previous section, are basically batch processes operating on a limited amount of organic matter. When really large concentrations of organic matter are required, it is much more efficient, as discussed below, to hold the adsorptive material in a column, through which the seawater is passed. After the proper amount of water has passed through the column, the organic matter can be desorbed with the proper choice of solvents. If the proper sequence of solvents is employed, a rough fractionation of the adsorbed material can be also result.

One of the earliest choices of adsorbent for seawater organics was activated charcoal [29, 32]. The technique has been refined for use in both fresh and seawater by a number of workers [33–36]. A major problem in this technique has been the unknown efficiencies of collection and desorption. Jeffrey [37] using ^{14}C -labelled material, found that 80% of the organic material in the seawater was adsorbed by the charcoal. Of that 80% approximately 8% again was desorbed by the solvents used. The overall efficiency of the method of collection is one of the few that permits the accumulation of gram amounts of organic materials from seawater and therefore also permits the application of many of the standard techniques of organic analysis. However, we do not know how the distribution of compounds is changed in the process of adsorption

and desorption; certain classes of compounds are probably entirely removed from the mixture, while others may be retained only in part. When so active a surface is used, there is also a possibility that chemical changes may take place during adsorption. The mixture as released from the charcoal may be considerably different from that original present in seawater. This collection method, although attractive for its simplicity and speed, is limited to qualitative results.

Macroreticular resins have also been used for the collection of trace organics.

An excellent early review of the properties of the various XAD resins, along with comparisons with EXP-500 and activated carbon, can be found in Gustafson and Paleos [38].

Riley and Taylor [39] have studied the uptake of about 30 organics from seawater onto the resin at pH 2–9. At the 2–5 $\mu\text{g/l}$ level none of the carbohydrates, amino acids, proteins or phenols investigated were adsorbed in any detectable amounts. Various carboxylic acids, surfactants, insecticides, dyestuffs, and especially humic acids are adsorbed. The humic acids retained on the XAD-1 resin were fractionated by elution with water at pH 7, M aqueous ammonia, and 0.2 M potassium hydroxide.

Osterroht [40,41] studied the retention of non-polar organics from seawater onto macroreticular resins.

Each of the XAD resins has slightly different properties and should collect a slightly different organic fraction from seawater. The major differences between the resins is in the degree of their polarity.

8.2 Volatile Compounds of Seawater

8.2.1 Gas Stripping

Whilst much of the literature on this subject is concerned with non-saline water samples, it is believed that many of these procedures will also work satisfactorily with seawater; indeed, the presence of salts in the sample may assist in the removal of volatiles.

In the collection of organic materials, separation of the more volatile materials can be achieved by transferring them into the vapour phase for collection and concentration. The usual method for effecting such a transfer is to bubble some inert gas through the liquid. The effluent gas is then passed through an adsorbent to collect the organic materials [42–47]. The desorbed material is then analysed by gas chromatography or by linked gas chromatography-mass spectroscopy.

Material removed from the water by stripping in this manner can also be concentrated by trapping in a loop immersed in a cooling bath. The usual cooling baths are liquid nitrogen or solid carbon dioxide with or without an

organic solvent. The major disadvantage of the liquid nitrogen bath, along with the cost and the limited availability, particularly aboard ship, is that it condenses carbon dioxide and water, along with the organic materials actually desired. These trapping techniques have been used by many workers and are usually described in conjunction with a gas chromatographic determination of some fraction of the organic materials. An example of this kind of separation is the work of Novak et al. [48]. They improved the yield of earth organics by salting out the volatiles with sodium sulfate.

While the gases used in stripping are usually air, nitrogen, or helium, electrolytically evolved hydrogen has been used as a collector for hydrocarbons [49]. In this technique, the gas is not passed through a column of adsorbent, but instead collects in the headspace of the container. Since the volume of seawater and of hydrogen are known, the hydrocarbon concentration in the headspace can be used to calculate the partition coefficients and the concentration of hydrocarbon in the seawater.

As in most of the separation methods, the stripping and collection techniques have not been investigated for their recovery efficiencies except in isolated instances. Kuo et al. [50] have found recovery efficiencies for volatile polar organics ranging from 9.5% for ethanol to 88.8% for acetone. Most of the model compounds displayed recovery efficiencies in the 60–80% region under the conditions of their experiment.

The Oil Companies International Study Group for Conservation of Clean Air and Water-Europe (Concawe) has made a detailed study [22] of the application of gas stripping to the determination of hydrocarbons in amounts down to parts per billion in water. In this procedure the water sample is purged with nitrogen and helium and the volatiles trapped on a solid adsorbent such as carbon. The organics are then released from the carbon by heating and purging directly into a gas chromatograph linked to a mass spectrometer. For chlorine and bromine containing impurities a halide selective detector such as the Hall electrolytic conductivity detector is used on the gas chromatograph. Alternatively an alkali flame ionization detector or an electron capture detector could be used.

Colenut and Thorburn [51, 52] have also described the procedure using gas stripping of the aqueous sample followed by adsorption onto active carbon from which surface they are taken up in an organic solvent for gas chromatographic analysis. They optimized conditions for the determination of parts per billion of pesticides and polychlorinated biphenyls.

The closed loop gas stripping system has been discussed by various workers [36, 53–56]. In this technique organic compounds are removed from water by purging with a gas saturated with water vapour. Volatile and semi-volatile compounds will partition out into the headspace and are swept to an activated charcoal trap. The charcoal will retain organics while allowing the purge gas to pass through. The purge gas is then returned to repurge the sample via a pump. At the end of the purge time, typically two hours, the trap is removed and fitted with a glass collection vial. Organic compounds are extracted from

the charcoal with a small volume of a suitable solvent such as carbon disulphide or dichloromethane, which is then collected and injected into a capillary gas chromatograph or a capillary gas chromatograph coupled with a mass spectrometer.

Grob and Zurcher [36, 53–55] have carried out very detailed and systematic studies of the closed loop gas stripping procedure and applied it to the determination of parts per billion of 1-chloroalkanes in water. Westerdorf [56] applied the technique to chlorinated organics and aromatic and aliphatic hydrocarbons.

Waggott [57] reported that a factor of major concern in adapting the technique to more polluted samples is the capacity of the carbon filter, which usually contains only 1.5–2 mg carbon. He showed that the absolute capacity of such a filter for a homologous series of 1-chloro-*n*-alkanes was 6 µg for complete recovery. Maximum recovery was dependent on carbon number, being at a maximum between C₈ and C₁₂ for the 1-chloro-*n*-alkane series. It is important, therefore, to balance the amount of sample stripped with the capacity of the carbon filter to obtain better than 90% recoveries.

8.2.2

Headspace Analysis

Corwen [58] used this method for the analysis of ketones and aldehydes in seawater. Halocarbons were similarly separated from environmental samples by Kaiser and Oliver [59]. There have been many other applications of the technique [60–69]. The major advantage of the headspace method is simplicity in handling the materials. At most, only one chemical, the salt used in the salting-out procedure, needs to be added and in most cases the headspace gas can be injected directly into a gas chromatograph or carbon analyser. On the other hand the concentration of organic materials present is limited by the volume of seawater in the sample bottle. This is very much a batch process.

Equilibration between the headspace gas and the solution can take a considerable time. This is not a problem when the salting-out material is added at sea and the samples are then brought into the laboratory for analysis some time later. When the salting-out is done in the laboratory, equilibration can be hastened by recirculating the headspace gas through the solution. A system could be devised which would permit the accumulation of volatiles from a large volume of water into a relatively small headspace, perhaps by recirculating both water and headspace gas through a bubbling and collection chamber, but much of the simplicity and freedom from possible contamination would be lost in the process.

Volatile organic materials can also be removed from solution by distillation, either at normal or at elevated pressures. While the amounts to be collected in this fashion are small, if headspace samples are taken at elevated temperatures and pressures, trace quantities of organics can be detected [70]. It should be

emphasized, however, that whenever extreme conditions are employed to free an organic fraction, that fraction is defined by the conditions of the separation and cannot profitably be compared with fractions defined by different sampling conditions. The use of elevated temperatures and pressures may also alter the compounds separated, limiting the amount of information that can be extracted from the analyses.

Friant and Suffet [66] have investigated in detail the interactive effects of temperature, salt concentration, and pH on headspace analysis for isolating volatile trace organics in aqueous samples. Optimal conditions were derived from a statistical evaluation of the effect of parameter variation on the partition coefficient. These were a pH of 7.1, a sample temperature of 50 °C, and a salt concentration equivalent to 3.35 M sodium sulfate. Dowty et al. [63] passed the headspace purge gas through a column of Tenax GC (poly (*p*-2,6-diphenyl-phenylene) oxide) adsorbent to trap the organics. The organics are then released from the Tenax GC and swept into a gas chromatograph for analysis in the parts per billion range. Bellar and Lichtenberg [65] also used the principle of adsorption of the organic components of the purge gas on a solid adsorbent material.

Chian et al. [69] point out that the Bellar and Lichtenberg [65] procedure of gas stripping followed by adsorption onto a suitable medium and subsequent thermal desorption onto a gas chromatograph-mass spectrometer is not very successful for trace determinations of volatile polar organic compounds such as the low molecular weight alcohols, ketones, and aldehydes. To achieve their required sensitivity of parts per billion, Chian et al. [69] carried out a simple distillation of several hundred ml of sample to produce a few ml of distillate. This achieved a concentration factor of between 10 and 100. The headspace gas injection-gas chromatographic method was then applied to the concentrate obtained by distillation.

8.2.3

Fractionation

Once a sample of dissolved organic matter has been isolated, it is still seldom in a form that permits simple analysis. In most cases, there are far too many compounds present and some form of fractionation must take place to remove interferences and simplify analytical procedures.

One could devise many different bases for the fractionation of organic materials, functional groups, degree of saturation, presence or absence of aromatic groups, and degree of polarity have all been used. The approach most often used is a fractionation by size. At the upper end of the size range we are dealing with particles consisting of many discrete molecules. Fractionation is accomplished by differential filtration, using filters and screens of decreasing pore size. A good example of the results of such fractionation is found in Sheldon [71].

Particles of smaller sizes, from the colloidal to the macromolecular, are separated by membrane filters. The most familiar of these is the Amicon Diflo filter, although several other companies now manufacture similar products. Separations in the same size range can also be achieved with hollow polymeric fibres. At the upper end of their size range, these filters can be used to separate different size classes of material normally considered as colloidal. At the smaller end, the separation is made on the basis of molecular size. The results are presented in terms of molecular weight, but the molecular weight calibration is done with spherical molecules. The results are therefore given as equivalent, spheres, rather than as true molecular weights. The techniques have been applied to coastal seawater. Ultrafiltration as a fractionation method gave recoveries of 80–100% when the carbon present in each fraction is summed.

Ultrafiltration techniques employing membrane filters and those using hollow fibres both worked well for the concentration and desalting of humic and fulvic acids, but the high priming volume needed for the hollow fibre apparatus restricts it to large volume applications. This is not likely to be a problem in marine work, where large volumes are required because of the low concentrations of organic materials. Both membranes and fibres retained material well below the expected molecular weight cut-off.

These techniques are now coming into use in marine organic chemistry. The apparatus is now available for processing large quantities of seawater, at pilot plant levels, to yield gram quantities of dissolved organic materials in specified molecular size classes. This should be one of the most fruitful methods for accumulation, separation, and rough fractionation of dissolved organic materials.

Separation into molecular size classes by ultra-filtration is necessarily discontinuous; the fractions resulting are composed of mixtures of compounds within a given band of molecular sizes. This kind of fractionation is best carried out by some form of column chromatography. If molecular size is to be the criterion for separation, then materials such as Sephadex can be used as column packing. Sephadex separates compounds by exclusion, holding the smaller molecules within the particles and rejecting those that will not fit within the pores of the resin. Thus with a Sephadex column, the large components come off the column first. The system is not perfect; some charged compounds, such as phenols, can be bound irreversibly to some of the resins. The procedure has been used in the analysis of natural waters [72, 73] but it has not been developed to its full usefulness.

XAD resins have been used to collect and concentrate organic materials from seawater. They can also be used as packings for fractionation by column chromatography. While they have been used in simple gravity flow column chromatography, high pressure liquid chromatography has also been used [74–78].

Reversed phase chromatography is a variant of high-performance liquid chromatography where a non-polar organic phase is immobilised and a polar

solvent is used as eluent. This variant may also be applied when non-polar compounds are to be sorbed from a polar solvent. This very situation is encountered in the attempt to accumulate non-polar organic substances from seawater by liquid–solid adsorption.

In applying the principle of reversed-phase chromatography to the accumulation of dissolved organic material from water, Ahling and Jensen [79] used a mixture of *n*-undecane and Carbowax 4000 monostearate on Chromosorb W as the collecting medium. Uthe and Reinke [80] tested porous polyurethane coated with liquid phases such as SE3, DC 200, QF-1, DEGS, OV-25, OV-225 for the same purposes. In each case the coating is achieved easily and may be modified to the desired adsorption properties. However, the coating is not chemically bonded to the support and may thus be removed together with the sorbate. Aue et al. [81] finally demonstrated the potential of support-bonded polysiloxanes for a simple, fast, and sensitive analysis of organochlorine compounds in natural aqueous systems.

Derenbach et al. [82] tested a technique for the accumulation of certain fractions of dissolved organic material from seawater; and subsequently for the fractionated desorption of the collected material.

The handling of water extracts and possible sources of contamination would thus be reduced to a minimum. Furthermore, fractionated desorption of the accumulated material under mild conditions should result in less complex mixtures with little risk of denaturation.

These workers investigated the suitability of numerous support materials for use in reversed-phase high-performance liquid chromatography for the recovery of non-polar organic compounds from seawater. Porous glass treated with trichloro-*n*-octadecyl silane was found to permit at least a semi-quantitative recovery of test compounds. This silanised glass support was found to be easy to keep free from contamination and in addition, had a relatively high adsorption capacity, permitting fractional desorption of the test compounds. Results obtained with this column were compared with those obtained using Amberlite XAD-2. Derenbach et al. [82] give full details of the preparation of this support material. They used ¹⁴C labelled spike compounds, 1-¹⁴C *n*-hexadecane and di(2-ethylhexyl) (carboxyl-¹⁴C)phthalate) and also non-labelled compounds (*n*C₆-*n*C₂₄ alkanes, diethyl, di-isobutyl, di-*n*-butyl, butylbenzyl dicyclohexyl, bisethylhexyl phthalic acid esters. *p,p'*-DDE DDMU Dieldrin pesticides) in recovery experiments.

Recoveries between 103% (dialkyl phthalates) and 71% (*n*-alkanes, dieldrin, eldrin) were reported when the technique was applied to 25 litre samples.

A disadvantage of the reversed-phase HPLC technique or that of Derenbach et al. [82] is that it is only semi-quantitative. Against this is the fact that the technique using silanised porous glass is easy to keep free of contamination, has a comparatively high adsorption capacity, and permits the fractionated desorption of accumulated material.

Hayase et al. [83] applied reversed phase liquid chromatography with double detectors (fluorescence and absorption) to the determination of dissolved organic matter in estuarine seawater. The dissolved organic matter was extracted into chloroform at pH 3 or 8. The hydrophilic–hydrophobic balance and aromatic character of the seawater-dissolved organic matter was represented on the chromatograms. The results indicated that reversed phase liquid chromatography with double detectors was an effective technique in the characterization of dissolved organic matter in seawater.

8.3 Chemical Pretreatment of Organics

In some cases, the forms in which the organic materials are present are not easily separated or identified. Some chemical pretreatment is necessary before the analytical procedures can be used. These pretreatments may include the preparation of volatile derivatives for use in gas chromatography, or the splitting of a large and otherwise intractable molecule, as in the hydrolysis of proteins to their constituent amino acids.

For many of the organic materials in seawater, some form of chemical pretreatment is necessary before analysis is possible. The obvious cases are the hydrolysis of polysaccharides and proteins before the analysis for monomeric constituents, and the formation of volatile derivatives to permit analysis by gas chromatography. These methods will be discussed further in Chap. 9.

More general reactions exist which are useful in determining the skeletal structure of unknown organic compounds. One such reaction is a treatment with hydrogen, resulting in the replacement of halogen, oxygen, sulfur, and nitrogen, and the saturation of double bonds [84]. The system is attached on-line in a gas chromatograph, the hydrogen being supplied by the carrier gas, the conversion taking place in a catalyst-containing tube. The resultant chromatographic pattern is greatly simplified, making identification of chemical structures somewhat easier.

Carbohydrazide can be used in a similar manner as a reducing agent, converting azo and nitro compounds to the corresponding amines for better volatilization. A considerable amount of literature exists on methods of this kind [85]; it has scarcely been used by marine chemists, perhaps because they are still concerned with concentration and isolation of compounds in seawater.

One form of chemical pretreatment that has been used more extensively is the oxidation of dissolved organic matter to carbon dioxide with high intensity ultraviolet light. This is the basis for at least one method of measurement of dissolved organic carbon; it has also been used for the measurement of stable carbon isotope ratios in dissolved and particulate organic matter [86, 87]. This measurement rests on the assumption that oxidation of all organics in seawater by ultraviolet light goes to completion, an assumption that is by no means proven.

References

1. Koyama T (1963) *Journal of the Oceanographic Society of Japan* **20**:563
2. Andelmen JB, Caruso SC (1971) Concentration and separation techniques. In: Ciaccio LL (ed) *Water and water pollution handbook*, vol 2. Marcel Dekker, New York, pp 483–591
3. Webb RG (1975) Isolating organic water pollutants, XAD resins, urethane foams, solvent extraction. US National Technical Information Service, PB report no. 245647
4. Whitby FJ (1975) *Proceedings of the Analytical Division of the Chemical Society* **12**:110
5. Fritz JS (1977) *Accounts of Chemical Research* **10**:67
6. Klein E, Eichelberger J, Ever C, Smith J (1975) *Water Res* **9**:807
7. Chian ESK, Bruce WN, Fang HHP (1975) *Environ Sci Tech* **9**:52
8. Deinzer H, Melton R, Mitchell D (1975) *Water Res* **9**:799
9. Kammerer Jr PA, Lee GF (1969) *Environmental Science and Technology* **3**:276
10. Pocklington R (1970) A new method for the determination of amino acids in sea water and an investigation of the dissolved free amino acids of North Atlantic Ocean waters. PhD Dissertation. Dalhousie University, pp 1–102
11. Shapiro J (1961) *Science* **133**:2063
12. Shapiro J (1967) *Anal Chem* **39**:280
13. Habermann HM (1963) *Science* **140**:292
14. Wallace Jr GT, Wilson DF (1969) Foam separations as a tool in chemical oceanography. Report no. 6958. US Naval Research Laboratory, p 1
15. Dorman DC, Lemlich R (1965) *Nature* **207**:145
16. Karger BL, DeVivo DG (1968) *Separation Science* **3**:393
17. Ahnoff M, Josefsson B (1976) *Anal Chem* **48**:1268
18. Ahnoff M, Josefsson B (1974) *Anal Chem* **46**:658
19. Wu C, Suffet IH (1977) *Anal Chem* **49**:231
20. Fielding W, Gibson TM, James HA, McLoughlin K, Steep CP (1981) Organic micropollutants in drinking water. Technical report TR 159. Water Research Centre, Medmenham, UK
21. Copin G, Barbier M (1971) *Oceanography* **23**:455
22. The Oil Companies International Study Group for Conservation of Clean Air and Water, Europe (1982) Analysis of trace substances in aqueous effluents from petroleum refineries. Concawe report no 6/82
23. Gomella C, Belle JP, Auvray J (1976) *J Techniques et Sciences Municipales* **71**:439
24. Werner AE, Waldichuk M (1962) *Anal Chem* **34**:1674
25. Neihof R, Loeb G (1974) *J Mar Res* **32**:5
26. Chave KE (1965) *Science* **148**:1723
27. Meyers PA, Quinn JG (1971) *Limnol Oceanog* **16**:992
28. Meyers PA, Quinn JG (1973) *Cosmochim Acta* **37**:1745
29. Jeffrey LM, Hood DW (1958) *J Mar Res* **17**:247
30. Williams PM, Zirino A (1964) *Nature* **204**:462
31. Chapman G, Rae AC (1967) *Nature* **214**:627
32. Wangersky PJ (1952) *Science* **115**:685
33. Vaccaro RF (1971) *Environ Sci Technol* **5**:134
34. Grob K (1973) *J Chromatogr* **84**:255
35. Kerr RA, Quinn JG (1975) *Deep Sea Res* **22**:107
36. Grob K, Zuercher F (1976) *J Chromatogr* **117**:285
37. Jeffrey LM (1969) Development of a method for isolating gram quantities of dissolved organic matter from seawater and some chemical and isotopic characteristics of the

- isolated material. PhD Dissertation. Texas A&M University, College Station, Texas USA p 152
38. Gustafson RL, Paleos J (1971) Interactions responsible for the selective adsorption of organics on organic surfaces. In: Faust SJ, Hunter JV (eds) *Organic compounds in aquatic environments*. Marcel Dekker, New York, pp 213–237
 39. Riley JP, Taylor D (1969) *Anal Chim Acta* **46**:307
 40. Osterroht C (1972) *Kiel. Meeresforsch* **28**:48
 41. Osterroht C (1974) *J Chromatogr* **101**:289
 42. Dravnieks A, Krotoszynski BK, Whitfield J, O'Donnell A, Burgwald T (1971) *Environ Sci Technol* **5**:1220
 43. Kaiser R (1972) *Haus Tech Essen Vortragsveroeff* **1972**:13
 44. Zlatkis A, Lichtenstein HA, Tichbee A (1973) *Chromatographia* **6**:67
 45. Bergert KH, Betz V, Pruggmayer D (1974) *Chromatographia* **7**:115
 46. Bertsch W, Chang RC, Zlatkis A (1974) *J Chromatog Sci* **12**:175
 47. Bertsch W, Anderson E, Hylser G (1975) *J Chromatogr* **112**:701
 48. Novak J, Zluticky J, Kubelka V, Mostecky J (1973) *J Chromatogr* **76**:45
 49. Wasik SP (1974) *J Chromatog Sci* **12**:845
 50. Kuo PRK, Chian ESK, DeWalle FB, Kim JH (1977) *Anal Chem* **49**:1023
 51. Colenut BA, Thorburn S (1980) *Int J Environ Anal Chem* **7**:231
 52. Colenut BA, Thorburn S (1980) *Int J Environ Anal Chem* **7**:25
 53. Grob K (1973) *J Chromatogr* **84**:255
 54. Grob K, Grob G (1974) *J Chromatogr* **90**:303
 55. Grob K, Grob G (1975) *J Chromatogr* **106**:299
 56. Westerdorf RG (1982) *Int Lab September*:32
 57. Waggott A, Reid WI (1977) Separation of non-volatile organic carbon in sewage effluent using high-performance liquid chromatography, pt 1. Technical report no. 52. Water Research Centre, Stevenage, UK
 58. Corwen JF (1970) Volatile organic materials in sea water. In: Hood W (ed) *Organic matter in natural waters*. Publication no. 1. Institute of Marine Science, University of Alaska, pp 169–180
 59. Kaiser KLE, Oliver BG (1976) *Anal Chem* **48**:2207
 60. Gjavotchanoff S, Luessen H, Schlimme E (1971) *Gas und Wasser* **112**:448
 61. Chesler SN, Gump BH, Hertz HP, May WE, Wise SA (1978) *Anal Chem* **50**:805
 62. Heyndrickx A, Peteghem C (1975) *Eur J Toxicol* **8**:275
 63. Dowty B, Green L, Laseter JL (1976) *J Chromatog Sci* **14**:187
 64. Waggott A (1978) *Proceedings of the Analytical Division of the Chemical Society* **15**:232
 65. Bellar TA, Lichtenberg JJ (1974) *J Amer Water Works Assoc* **566**:739
 66. Friant SE, Suffet IH (1979) *Anal Chem* **51**:2161
 67. Malter L, Vreden V (1978) *Forum Stadte-Hygiene* **29**:37
 68. Cowen WE, Cooper WJ, Hisfill JW (1975) *Anal Chem* **47**:2483
 69. Chian ESK, Kuo PPK, Cooper WJ, Cowen WE, Fuentes RC (1977) *Environ Sci Technol* **11**:282
 70. Luessem H (1972) *Haus Tech Essen Vortragveroeff* **1972**:69
 71. Sheldon RW (1972) *Limnol Oceanog* **17**:494
 72. Gjesing E, Lee FG (1967) *Environ Sci Technol* **1**:631
 73. Sirotkina IS, Varshal GM, Lur'e YY, Stepanova NP (1974) *Zhur Anal Khim* **29**:1626
 74. Pietrzyk DI, Chu CH (1977) *Anal Chem* **49**:757
 75. Pietrzyk DI, Chu CH (1977) *Anal Chem* **49**:860
 76. Scott RPW, Kucera P (1973) *Anal Chem* **45**:749
 77. Snyder LR (1974) *Anal Chem* **46**:1384

78. Engelhardt H (1975) Hochdruck Flüssigkeits-Chromatographie. Springer, Berlin, Germany
79. Ahling B, Jensen S (1970) *Anal Chem* **42**:1483
80. Uthe JF, Reinke J (1972) *Environ Lett* **3**:117
81. Aue WA, Kapila S, Hastings CR (1972) *J Chromatogr* **73**:99
82. Derenbach JR, Ehrhardt M, Osterroht C, Petrick G (1978) *Mar Chem* **6**:351
83. Hayase K, Shitashima K, Tsubota H (1985) *J Chromatogr* **322**:358
84. Beroza M (1962) *Anal Chem* **34**:1801
85. Rahn PC, Siggia S (1973) *Anal Chem* **45**:2336
86. Williams PM (1968) *Nature* **219**:152
87. Williams PM, Gordon LI (1970) *Deep Sea Res* **17**:19

9 Organic Compounds

While there has always been some interest in the nature of the organic compounds in seawater, identification of actual compounds has progressed slowly because of the low concentrations present. With a total organic carbon concentration of 0.5–1.5 mg/l of carbon, the total concentration of any single organic compound is likely to be less than 10^{-7} M. Therefore, in the past, identification of individual compounds has been limited to those few for which specific, sensitive chemical methods existed. These methods were usually spectrophotometric, and were often developments of methods originally used in clinical chemistry.

The advent of the newer physical methods of separation and identification, together with the impetus given to the field by the imposition of anti-pollution legislation, has resulted in a flood of new and often unproven methods. While most of these methods were specifically designed to measure materials added to the environment by man's activities, in many cases they have added greatly to our knowledge of the naturally occurring compounds as well.

Until the advent of modern instrumental methods of analysis, the best we could hope to do was to measure the amounts of certain broad classes of compounds present, as, for example, the total protein or total carbohydrate.

Using the newer methods, such as gas chromatography, liquid–liquid chromatography, fluorometry, and mass spectrometry, it is possible to measure many compounds at the parts-per-billion level, and a few selected compounds with special characteristics at the parts-per-trillion level. Even with these sensitivities, however, a considerable concentration must usually be undertaken to permit the chemical or physical fractionation necessary to render the final analyses interpretable. A major effort has therefore been expended on the study of methods of separation and concentration, and this is discussed further in Chap. 8.

A problem which has been less well recognised is that of contamination in sampling and sample handling. The oceanographic vessel itself is a major source of contamination; from the moment that the ship stops on station, a surface film of oil, flakes of metal and rust spreads out in all directions. The means of sampling also often acts as a source of contamination. Once the sample is on board, along with the normal problems of contamination through sample handling and through high blank values from the reagents used, we

must also attempt to cope with chemical and biological changes occurring during storage, since many of the modern instruments are not easily taken to sea. In environmental chemistry, the work of Analyst does not begin with the delivery of the sample to the laboratory; every aspect of sampling, storage, and pretreatment must be considered part of the analyst's domain. This is discussed further in Chap. 1.

Hydrocarbons

Probably the most studied group of organic compounds in seawater is the hydrocarbons, not because of the importance of the naturally occurring materials, but because of the continuing threat of large-scale pollution. However, the methods devised for the measurement of anthropogenic hydrocarbons will also measure the natural materials. A major problem, not altogether solved, is that of distinguishing between the two sources.

There have been many reviews of analytical methods for hydrocarbons, particularly those given in [1–11].

Burgess [538] has reviewed the characterisation and identification of organic toxicants in marine waters

9.1

Aliphatic Hydrocarbons

9.1.1

Spectrofluorometry

Fam et al. [11] determined hydrocarbons in run-off water from catchments in San Francisco Bay using liquid chromatography and high-resolution gas chromatography.

Wade and Quinn [12] measured the hydrocarbon content of sea surface and subsurface samples. Hydrocarbons were extracted from the samples and analysed by thin-layer and gas-liquid chromatography. The hydrocarbon content of the surface micro layer samples ranged from 14 to 599 $\mu\text{g/l}$ with an average of 155 $\mu\text{g/l}$, and the concentration in the subsurface samples ranged from 13 to 239 $\mu\text{g/l}$ and averaged 73 $\mu\text{g/l}$. Several isolated hydrocarbon fractions were analysed by infrared spectrometry and each fraction was found to contain a minimum of 95% hydrocarbon material, including both alkenes and aromatics.

9.1.2

Dynamic Headspace Analysis

May et al. [13] have described a gas chromatographic method for analysing hydrocarbons in marine sediments and seawater which is sensitive at the

sub microgram per kilogram level. Dynamic headspace sampling for volatile hydrocarbon components, followed by coupled-column chromatography for analysing the nonvolatile components, requires minimal sample handling, thus reducing the risk of sample component loss and/or sample contamination. The volatile components are concentrated on a Tenax gas chromatographic precolumn and determined by gas chromatography or gas chromatography-mass spectrometry.

Other workers have discussed the application of dynamic headspace analysis to the determination of aliphatic hydrocarbons in seawater [14–18].

A second system, the removal of volatiles by vacuum, can be set up in two ways; either as a flow-through or as a batch process. As a flow-through process, the sample is drawn continuously through the system, and the gases taken off by the vacuum pass through a sampling loop. Periodically, the material in the loop is injected into the gas chromatograph. In this manner it is possible to derive almost continuous profiles of volatile hydrocarbon concentrations [19].

In the batch mode, a larger sample can be treated over a longer period, and the volatiles collected by cold-trapping or adsorption. These techniques are not as fast as flow-through sampling, nor do they permit semi-continuous profiling, but they result in greater concentrations of the hydrocarbons, and thus in greater sensitivity [20].

The third technique, stripping-out, is by far the most common. In this technique, an inert gas is bubbled through the sample to remove the volatile materials. When the concentration of hydrocarbons is great enough, as, perhaps, after a petroleum spill, the emergent gas stream can be sampled directly [21]. This is seldom the case in true oceanic samples, however, and some form of concentration is needed.

It is possible to collect the volatiles in a cold trap [22]. A more favoured technique is the collection of the gases by adsorption on some support such as one of the Chromosorbs, or Tenax GC [13, 22, 23]. The volatiles are then desorbed by heating and injected into a gas chromatograph.

Of the three general methods, the last seems to be the most practical. Theoretically, with high enough concentrations of hydrocarbons, the first method, the headspace analysis, should be both the most accurate and the easiest to calibrate. Operationally, it leaves much to be desired both because of the problems of sensitivity and those of the accommodation of the larger molecules in water. The second method, vacuum degassing, requires much more equipment than the third method and requires that large amounts of water vapor be removed before the sample is injected into the gas chromatograph. The last method is so much less complicated that even with its calibration problems it has been adopted almost universally.

While the gases used in stripping are usually air, nitrogen, or helium, electrolytically evolved hydrogen has been used as a collector for hydrocarbons [24]. In this technique the gas is not passed through a column of adsorbent, but instead collects in the headspace of the container. Since the volume

of seawater and of hydrogen is known, the hydrocarbon concentration in the headspace can be used to calculate the partition coefficients and the concentrations of hydrocarbon in the seawater. This method is capable of determining 1 $\mu\text{g/l}$ of volatile hydrocarbons in seawater.

9.1.3

Raman Spectroscopy

Ahmadyian and Brown [25] have used laser Raman spectroscopy to identify petroleums.

9.1.4

Flow Calorimetry

Zsolnay and Kiel [26] have used flow calorimetry to determine total hydrocarbons in seawater. In this method the seawater (1 litre) was extracted with trichlorotrifluoroethane (10 ml) and the extract was concentrated, first in a vacuum desiccator, then with a stream of nitrogen to 10 μl . A 50 μl portion of this solution was injected into a stainless steel column (5 cm \times 1.8 mm) packed with silica gel (0.063–0.2 mm) deactivated with 10% of water. Elution was effected, under pressure of helium, with trichlorotrifluoroethane at 5.2 ml per hour and the eluate passed through the calorimeter. In this the solution flowed over a reference thermistor and thence over a detector thermistor. The latter was embedded in porous glass beads on which the solutes were adsorbed with evolution of heat. The difference in temperature between the two thermistors was recorded. The area of the desorption peak was proportional to the amount of solute present.

9.2

Aromatic Hydrocarbons

9.2.1

Spectrofluorometry

Booksh et al. [27] employed an excitation/emission matrix imaging spectrofluorometer for quantitation of two fluorescent compounds, naphthalene and styrene, contained in ocean water exposed to gasoline. Multidimensional parallel factor (PARAFAC) analysis models were used to resolve the naphthalene and styrene fluorescence spectra from a complex background signal and overlapping spectral interferents not included in the calibration set. Linearity was demonstrated over 2 orders of magnitude for determination of naphthalene with a detection limit of 8 parts per billion. Similarly, nearly 2 orders of magnitude of linearity were demonstrated in the determination of styrene with an

11 ppb limit of detection. Furthermore, the synthesis of the EEM spectrofluorometer and the PARAFAC analysis for unbiased prediction of naphthalene and styrene concentration in mixture samples containing uncalibrated spectral interferents was demonstrated.

9.2.2

High-Performance Liquid Chromatography (HPLC)

By its very nature, the gas chromatograph is only useful with those compounds which can be made volatile in some manner. Compounds that are nonvolatile at the temperatures that can be achieved in the gas chromatograph injection port, or those that degrade and polymerise, will be left as a residue in the injection port or at the top of the column. For these compounds, high-performance liquid chromatography is the natural technique. The weak point of this technique has been the sensitivity of the detectors; the common commercially available detectors measure refractive index, and light absorption and fluorescence in the ultraviolet and visible. Of these, only the fluorescence detector can approach the sensitivity of the gas chromatograph detectors, and it is useful only for those few compounds that are naturally fluorescent. There have also been attempts to link the liquid chromatograph to flame ionisation detectors and atomic absorption spectrometers.

HPLC has been used, with an ultraviolet absorption detector set for 254 nm, for the determination of aromatic hydrocarbons and with a flow calorimeter for the detection of all hydrocarbons. Increased sensitivity and decreased interference can be achieved with the ultraviolet absorption detector by measuring absorption at two wavelengths and using the ratios of the absorption at those wavelengths [28].

9.3

Polyaromatic Hydrocarbons

Hiltabrand [29] has investigated the fluorometric determination of polyaromatic aromatic hydrocarbons in seawater.

Payne [30] carried out a field investigation of benzopyrene hydrolysate induction as monitor for marine petroleum pollution. Isaaq et al. [31] isolated stable mutagenic ultraviolet photodecomposition products of benzo(a)pyrene by thin-layer chromatography.

Fuoco et al. [539] has reported the analysis of priority pollutants in seawater using online supercritical fluid chromatography, cryotrap gas chromatography-mass spectrometry. Using this system polynuclear aromatic hydrocarbons and polychlorobiphenyls were measured in seawater with recoveries better than 75%.

Law et al. [540] have recently reviewed methods for the analysis of polyaromatic hydrocarbons in marine water.

9.4 Oil Spills

In the early days of pollution research, many methods were investigated in the hope of finding a single technique which would infallibly link the deed and the doer, the oil spill and the leaking container. The research was aided by a number of cases in which the provenance was obvious; the *Torrey Canyon* and the *Arrow* incidents are two examples. Thus it was possible to study the changes brought about by weathering and to discover how these changes would hamper identification of the source of the spill. The difficulty of attempting such identification using only a single technique was clearly shown by the number of proposals to add radioactive or chemical labels to petroleum products as they were loaded into the tankers.

Of the methods developed for the identification of hydrocarbon mixtures, only coupled gas chromatography–mass spectrometry holds any real promise of certain identification and this only at a prohibitive cost in time spent characterising minor peaks. It would be far more efficient to develop rapid screening procedures which would eliminate all but a few possibilities, and then use gas chromatography–mass spectrometry to isolate and identify a few key peaks to confirm the characterisation. This is precisely the scheme adopted independently by a number of laboratories.

9.4.1 Spectrofluorometry

This method was originally used to detect oil in surveys of oil in seawater (Zitko and Carson [32]; Michalik and Gordon [33]; Levy [34, 35]; Levy [36]).

Van Duuren [37] examined the use of emission and excitation spectra in the identification of aromatic hydrocarbons. Contour diagrams of fluorescence activity at various excitation and emission wavelengths have been used as a means of identifying petroleum residues.

However, the main use of fluorescence has been in the semi-quantitative determination of aromatic hydrocarbons by extraction into an organic solvent, followed by excitation at a standard wavelength and comparison with the emission from a chosen standard. These techniques have been studied by many workers [38–42].

The difficulties in the use of fluorescence for quantitative measurement of hydrocarbons are much like those for the ultraviolet absorption methods. Each compound has its own excitation and emission maxima, with the fluorescence quantum yields varying sometimes by an order of magnitude. Thus the amount of hydrocarbon reported by an analysis will depend upon the emission and excitation wavelengths chosen, and upon the compound selected as the standard.

Petroleum products contain many fluorescing compounds, e.g., aromatic hydrocarbons, polycyclic aromatic hydrocarbons, and various heterocyclic

compounds. The use of fluorescence technique and instrumentation has led to the use of this technique for the identification of crude and residual oil pollutants in a marine environment [43, 44] and of motor oils and related petroleum products [45–48].

Maher [49] used fluorescence spectroscopy for monitoring petroleum hydrocarbon contamination in estuarine and ocean waters.

An ingenious variation on the standard fluorescence methods was proposed by Red'kin et al. [50]. Water samples were extracted with non-polar solvents, transferred into hexane and the hexane solution frozen at 77 K. At that temperature the normally diffuse luminescence emission bands are present as sharp emission lines, making identification of fluorescing compounds considerably simpler. In the case of a complex mixture, some separation by column or thin layer chromatography might be necessary.

Second-order and fourth-order derivative synchronous spectrometry has been used to fingerprint crude oil and fuel oil spills in seawater [51].

9.4.2

Infrared Spectroscopy

Kawahara [52–54] has described an infrared spectroscopic method applicable to essentially nonvolatile petroleum products.

Heavy residual fuel oils and asphalts are not amenable to gas chromatography and give similar infrared spectra. However, a differentiation can be made by comparing certain absorption intensities [52]. Samples were extracted with chloroform, filtered, dried, and the solvent evaporated off at 100 °C for a few minutes using an infrared lamp. A rock salt smear was prepared from the residue in a little chloroform, and the final traces of solvent removed using the infrared lamp. The method, which in effect compares the paraffinic and aromatic nature of the sample, involves calculation of the following absorption intensity ratios:

- $(13.88 \mu\text{m polymethylene chain}) / (7.27 \mu\text{m methyl groups})$
- $(3.28 \mu\text{m aromatic C-H}) / (3.42 \mu\text{m aliphatic C-H})$
- $(12.34 \mu\text{m aromatic rings}) / (7.27 \mu\text{m methyl groups})$
- $(6.25 \mu\text{m aromatic C-C}) / (7.27 \mu\text{m methyl groups})$
- $(12.34 \mu\text{m aromatic rings}) / (13.88 \mu\text{m polymethylene chain})$
- $(6.25 \mu\text{m aromatic C-C}) / (13.88 \mu\text{m polymethylene chain})$

Peaks observed at 5.90 μm and 8.70 μm were thought to reflect oxidative effects on the asphaltic material, while asphaltic sulfoxide and sulfone were tentatively inferred from bands at 9.76, 8.66, and 7.72 μm . The 12.34/13.88, 12.34/7.27, and 6.25/13.88 μm ratios tended to show the greatest difference between different samples. When the ratio 12.34/7.27 μm versus 12.34/13.88 μm were plotted graphically, the intermediate fuel oils behaved similarly [53]. Weathering caused fuel oils to fall below the curve although with asphalts the effect was

significantly less. Since no prior purification was employed the method relies on an uncontaminated, unweathered sample of oil being available.

Mattson and Mark [55,56] reported some criticism of Kawahara's technique. They claim that evaporation of the solvent chloroform by infrared heating removes volatiles and causes large changes in the ratios. An oil sample was shown to suffer such alteration by the infrared during repeated analysis. The absorption of all bands decreased nonuniformly between 20 and 100% over a period of 30 min. They propose the application of internal reflection spectrometry as a rapid, direct qualitative technique requiring no sample pretreatment.

In contrast to infrared spectrometry there is no decrease in relative sensitivity in the lower energy region of the spectrum, and since no solvent is required, no part of the spectrum contains solvent absorptions. Oil samples contaminated with sand, sediment, and other solid substances have been analysed directly, after being placed between 0.5 mm 23-reflection crystals. Crude oils, which were relatively uncontaminated and needed less sensitivity, were smeared on a 2 mm 5-reflection crystal. The technique has been used to differentiate between crude oils from natural marine seepage, and accidental leaks from a drilling platform. The technique overcomes some of the faults of infrared spectroscopy, but is still affected by weathering and contamination of samples by other organic matter. The absorption bands shown in Table 9.1 are important in petroleum product identification.

Kawahara and Ballinger [53, 57] has used their method to characterise a number of known and unknown petroleum samples. All of these studies used the normal transmission method to obtain infrared spectra; however, the feasibility of using internal reflection to obtain infrared spectra has been demonstrated by several groups (Mattson and Mark [55], Mark et al. [58],

Table 9.1. Absorption bands important in petroleum products identification

Band (μm)	Compound
3.23 – 2.78	Water
3.28	Aromatic CH
3.29	– CH ₃
3.42	> CH ₂
3.51	> CH ₂
5.88	> C = O
6.25	Aromatic C–C
6.90	> CH ₂
7.27	– CH ₃
9.71	> S=O, PO ₄
11.63	Aromatic CH
13.60	Aromatic CH
13.98	Long chain –CH ₂ –

Source: Author's own files

Baier [59]). The advantage of the latter method is that chemical extraction of petroleum from such as sand and water is unnecessary.

Pierre [60] has reported a study of the characterisation of the surface of oil slicks by infrared reflective spectroscopy. A double-beam spectrophotometer was modified for studying the reflectance spectra (at angles of incidence 45°, 60°, 70°) of oil layers (20–30 μm thick) on the surface of water using pure water as reference.

Various other workers have discussed the application of this technique to oil spill analysis [61–63].

9.4.3

Gas Chromatography

Various workers have discussed this technique [43, 64–72].

Ramsdale and Wilkinson [66] have identified petroleum sources of beach pollution by gas chromatography. Samples containing up to 90% of sand or up to 80% of emulsified water were identified, without pretreatment by gas chromatography, on one of a pair of matched stainless steel columns (750 \times 3.2 mm id) fitted with precolumns (100 mm) to retain material of high molecular weight, the second column being used as a blank. The column packing is 5% of silicone E 301 on Celite (52–60 mesh), the temperature is programmed at 5 °C per minute from 50 °C to 300 °C, nitrogen was used as carrier gas, and twin flame ionisation detectors were used.

Adlard et al. [74] improved the method of Ramsdale and Wilkinson [66] by using an S-selective flame photometric detector in parallel with the flame ionisation detector. Obtaining two independent chromatograms in this way greatly assists identification of a sample. Evaporative weathering of the oil samples has less effect on the information attainable by flame photometric detection than on that attainable by flame ionisation detection. A stainless steel column (1 m \times 3 mm id) packed with 3% of OV-1 on AWDMCS Chromosorb G (85–100 mesh) was used, temperature programmed from 60 °C to 295 °C per minute with helium (35 ml/min) as carrier gas, but the utility of the two-detector system is enhanced if it is used in conjunction with a stainless steel capillary column (20 \times 0.25 mm) coated with OV-101 and temperature programmed from 60 °C to 300 °C at 5° per minute, because of the greater detail shown by the chromatograms.

Brunnock et al. [67] have also determined beach pollutants. They showed that weathered crude oil, crude oil sludge, and fuel oil can be differentiated by the *n*-paraffin profile as shown by gas chromatography, wax content, wax melting point, and asphaltene content. The effects of weathering at sea on crude oil were studied; parameters unaffected by evaporation and exposure are the contents of vanadium, nickel, and *n*-paraffins. The scheme developed for the identification of certain weathered crude oils includes the determination of these constituents, together with the sulfur content of the sample.

Adlard and Matthews [75] applied the flame photometric sulfur detector to pollution identification. A sample of the oil pollutant was submitted to gas chromatography on a stainless steel column (1 m × 3 mm) packed with 3% of OV-1 on AWDMCS Chromosorb G (85–100 mesh). Helium was used as carrier gas (35 ml/min) and the column temperature was programmed from 60 °C to 295 °C at 5° per minute. The column effluent was split between a flame ionisation and a flame photometric detector. Adlard and Matthews [75] claim that the origin of oil pollutants can be deduced from the two chromatograms. The method can also be used to measure the degree of weathering of oil samples.

Boylan and Tripp [76] determined hydrocarbons in seawater extracts of crude oil and crude oil fractions. Samples of polluted seawater and the aqueous phases of simulated samples (prepared by agitation of oil–kerosene mixtures and unpolluted seawater to various degrees) were extracted with pentane. Each extract was subjected to gas chromatography on a column (8 ft × 0.06 in) packed with 0.2% of Apiezon L on glass beads (80–100 mesh) and temperatures programmed from 60 °C to 220 °C at 4 °C per minute. The components were identified by means of ultraviolet and mass spectra. Polar aromatic compounds in the samples were extracted with methanol-dichloromethane (1:3).

Investigations on pelagic tar in the North West Atlantic have been carried out using gas chromatography [77]. This report collects together the results of various preliminary investigations. It is in the Sargasso Sea where the highest concentrations (2–40 mg/m²) occur, and on beaches of isolated islands, such as Bermuda. These workers discuss the occurrence, structure, possible sources, and possible fate of tar lumps found on the surface of the ocean.

Zafiron and Oliver [78] have developed a method for characterising environmental hydrocarbons using gas chromatography. Solutions of samples containing oil were separated on an open-tubular column (50 ft × 0.02 in) coated with OV-101 and temperature programmed from 75 °C to 275 °C at 6 °C per minute; helium (50 ml/min) was used as carrier gas and detection was by flame ionisation. To prevent contamination of the columns from sample residues the sample was injected into a glass-lined injector assembly, operated at 175 °C, from which gases passed into a splitter before entering the column. Analysis of an oil on three columns gave signal intensity ratios similar enough for direct comparison or for comparison with a standard. The method was adequate for correlating artificially weathered oils with sources and for differentiating most of 30 oils found in a sea port.

Garra and Muth [80] and Wasik and Brown [81] characterised crude, semi-refined, and refined oils by gas chromatography. Separation followed by dual-response detection (flame ionisation for hydrocarbons and flame photometric detection for S-containing compounds) was used as a basis for identifying oil samples. By examination of chromatograms, it was shown that refinery

oils can be artificially weathered so that the source of the oils can be determined.

Hertz et al. [79] have discussed the methodology for the quantitative and qualitative assessment of oil spills. They describe an integrated chromatographic technique for studies of oil spills. Dynamic headspace sampling, gas chromatography, and coupled-column liquid chromatography are used to quantify petroleum-containing samples, and the individual components in these samples are identified by gas chromatography and mass spectrometry.

Rasmussen [82] describes a gas chromatographic analysis and a method for data interpretation that he has successfully used to identify crude oil and bunker fuel spills. Samples were analysed using a Dexsil-300 support coated open tube (SCOT) column and a flame ionisation detector. The high-resolution chromatogram was mathematically treated to give "GC patterns" that were a characteristic of the oil and were relatively unaffected by moderate weathering. He compiled the "GC patterns" of 20 crude oils. Rasmussen [82] uses metal and sulfur determinations and infrared spectroscopy to complement the capillary gas chromatographic technique.

The gas chromatograms of most oil samples examined had similar basic features. All were dominated by the *n*-paraffins, with as many as 13 resolved but unidentified smaller peaks appearing between the *n*-paraffin peaks of adjacent carbon numbers. Each oil had the same basic peaks, but their relative size within bands of one carbon number varied significantly with crude source.

9.4.4

Gas Chromatography–Mass Spectrometry (GC–MS)

In some cases it is necessary unambiguously to identify selected components separated during gas chromatographic examination of oil spill material. Such methods are needed from the standpoint of the enforcement of pollution control laws. The coupling of a mass spectrometer to the separated components emerging from a gas chromatographic separation column enables such positive identifications to be made.

Smith [83] classified large sets of hydrocarbon oil infrared spectral data by computer into "correlation sets" for individual classes of compounds. The correlation sets were then used to determine the class to which an unknown compound belongs from its mass spectral parameters. A correlation set is constructed by use of an ion-source summation, in which a low resolution mass spectrum is expressed as a set of numbers representing the contribution to the total ionisation of each of 14 ion series. The technique is particularly valuable in the examination of results from coupled gas chromatography–mass spectrometry of complex organic mixtures.

Walker et al. [84] examined several methods and solvents for use in the extraction of petroleum hydrocarbons from estuarine water and sediments, during an in situ study of petroleum degradation in sea water. The use of

hexane, benzene, and chloroform as solvents is discussed and compared, and quantitative and qualitative differences were determined by analysis using low-resolution computerised mass spectrometry. Using these data, and data obtained following the total recovery of petroleum hydrocarbons, it is concluded that benzene or benzene-methanol azeotrope are the most effective solvents.

Brown and Huffman [85] reported an investigation of the concentration and composition of nonvolatile hydrocarbons in Atlantic Ocean and nearby waters. Sea water samples were taken at depths of 1 and 10 m and the non-volatile hydrocarbons were identified by mass spectrometric techniques. The results show that the nonvolatile hydrocarbons in Atlantic and nearby waters contained aromatics at lower concentrations than would be expected if the source of the hydrocarbons were crude oil or petroleum refinery products. Hydrocarbons appeared to persist in the water to varying degrees, with the most persistent being the cycloparaffins, then isoparaffins, and finally the aromatics.

Albaiges and Albrecht [86] propose that a series of petroleum hydrocarbons of geochemical significance (biological, markers) such as C_{20} – C_{40} acyclic isoprenoids and C_{27} steranes and triterpenes be used as passive tags for the characterisation of oils in the marine environment. They use mass fragmentography of samples to make evident these series of components without resorting to complex enrichment treatments. They point out that computerised gas chromatography–mass spectrometry permits multiple fingerprinting from the same gas chromatographic run. Hence rapid and effective comparisons between samples and long-term storage of the results for future examination can be carried out.

Another relevant feature of the gas chromatographic profile is the acyclic isoprenoid hydrocarbon pattern that is made evident with capillary columns or by the inclusion of the saturated fraction in 5 Å (0.5 nm) molecular sieves or in urea. The predominant peaks usually correspond to the C_{19} (pristaine) and C_{20} (phytane) isomers, which ratios serve as an identification parameter [87], although the series extends to lower and higher homologues.

The sulfur compounds that are present in minor quantities in petroleum products also exhibit a typical gas chromatographic fingerprint easily obtained by flame photometric detection. This fingerprint has been introduced to complement the flame ionisation detection chromatogram with the aim of resolving the ambiguities or increasing the reliability in the identification of the pollutants [74].

All the above fingerprints exhibit a different usefulness for characterising oils. Their variation between crudes and their resistance to the sea weathering processes are not enough, in many cases, for providing the unequivocal identification of the pollutant. The *n*-paraffins can, apparently, be removed by biodegradation, as can the lower acyclic isoprenoids at respectively slower rates.

9.4.5

Miscellaneous

Other techniques that have been used in the examination of hydrocarbons in seawater resulting from oil spills include gel permeation chromatography [88], mass spectrometry [85], turbidimetry [89, 90], and paper chromatography [91].

Characterisations of crude oil based on their metal [65,92], nitrogen [92,93], and sulfur [99] contents have been carried out.

9.5

Carboxylic Acids and Hydroxy Acids

9.5.1

Spectrophotometric Method

If a measurement of total fatty acid concentration is desired, short of attempting to sum the amounts of each compound found by gas chromatography, some indirect method must be employed. Harwood and Huyser [94] made iron (III) hydroxamates of the fatty acids and measured these colorimetrically.

Antia et al. [96] proposed a colorimetric method comprising a concentration step and a reaction with 2,7-dihydroxynaphthalene. This method has a detection limit of 0.1 mg/l. Methods comprising concentration by adsorption on alumina, followed by elution and colour development, yielded a detection limit of 5 ng/l [97, 98]. These methods have not been too successful in hands other than those of the original authors, possibly because of the amount of manipulation necessary in the analysis.

Stradomskaya and Goncharova [99] have developed an extraction and colour development method for formic acid which should work in seawater. The sample is acidified to pH 2 and extracted with diethyl ether. After removal of the ether, the formic acid is reduced to formaldehyde and determined spectrophotometrically with chromotropic acid. A sensitivity of 1 µg/l with a normal range of 0.9 µg/l is claimed.

9.5.2

Gas Chromatography

Trifluoroacetate has been determined in seawater in amounts down to 32 ng/l by extraction with methyl *tert* butyl ether and derivatised with pentafluorophenyl diazomethane prior to gas chromatography mass spectrometry (negative ionisation) [541].

One of the earliest applications of gas chromatography to marine problems was in the measurement of fatty acids in seawater. In general, the gas chromatographic method has employed extraction into organic solvent, followed by the

formation of a volatile derivative, often the methyl ester. Garrett et al. [100] applied these techniques to materials collected from the surface layer, finding fatty acids from C_8 – C_{20} to be present. Slowey et al. [101] applied similar analytical techniques to material isolated from the water column.

Earlier analytical results from the gas chromatographic analysis of fatty acids seemed to be very high. Williams [102] repeated much of the early work, using extreme care in the avoidance of contamination, and found very much smaller quantities. Papers concerned with the fatty acid content of the water column and sediment include [103–109].

Analyses of the surface film have been performed [110–114] and analytical methods for the volatile members of the group have been reported [115–118].

Gas chromatography and gas chromatography–mass spectrometry have also been used to measure fatty alcohol [119], phytol [120], and the several isomers of inositol [121].

9.5.3

Liquid Chromatography

All of the various chromatographic methods have been used for the separation and subsequent determination of the individual fatty acids. The earlier work used column and paper chromatography for the concentration and separation of the acids, with spectrophotometric methods for the final measurement. Mueller et al. [122] concentrated carboxylic acids by evaporation and extraction, then separated them by column and paper chromatography. Koyama and Thompson [123] used vacuum distillation and extraction for the concentration step, and column chromatography for the separation. Maksimova and Pimenova [124], working with culture medium in which phytoplankton had been grown, separated derivatives of the fatty acids on paper chromatograms. These methods, although effective, are tedious; if they were to be attempted today, they would undoubtedly be adapted to thin-layer and liquid chromatography.

The fatty acids measured by these techniques have all been small monomeric molecules. Lamar and Goerlitz [125] studied the acidic materials in highly coloured water and found that most of the nonvolatile material was composed of polymeric hydroxy carboxylic acids, with some aromatic and olefinic unsaturation. Their methods included gas, paper, and column chromatography with infrared spectrophotometry as the major technique used for the actual characterisation of the compounds.

Horikawa [126] has adapted a thermal detector for the determination of formic, acetic, and propionic acids by liquid chromatography.

Gorcharova and Khomenko [127] have described a column chromatographic method for the determination of acetic, propionic, and butyric acids in seawater, and thin-layer chromatographic methods for determining lactic, aconitic, malonic, oxalic, tartaric, citric, and malic acids. The pH of the sample is adjusted to 8–9 with sodium hydroxide solution. It is then evaporated almost

to dryness at 50–60 °C and the residue washed on a filter paper with water acidified with hydrochloric acid. The pH of the resulting solution is adjusted to 2–3 with hydrochloric acid (1:1), the organic acids are extracted into butanol, then back-extracted into sodium hydroxide solution; this solution is concentrated to 0.5–0.7 ml, acidified and the organic acids separated on a chromatographic column.

Application of high-performance liquid chromatography to the resolution of complex mixtures of fatty acids [128, 129] has provided an alternative to the high temperature separation obtained by gas chromatography. Both techniques have similar limits of detection, but lack the ability to analyse directly environmental samples. Analysis requires that the fatty acids be separated from the organic and inorganic carbon matrices followed by concentration. Typically, these processes can be accomplished simultaneously by the appropriate choice of methods. Initial isolation of the fatty acids is based on the relative solubility of the material of interest in an organic phase compared with the aqueous phase. Secondary separation is determined by the functional group content and affinity for a solid support.

A coupled enzymic high-performance liquid chromatographic method has been used to determine down to 0.1–0.8 μM of formate in sea water [130].

9.5.4

Atomic Absorption Spectrometry (AAS)

Treguer et al. [95] determined total dissolved free fatty acids in sea water. The sample (1 litre) was shaken with chloroform (2×20 ml) to remove the free fatty acids and the extract evaporated to dryness under reduced pressure at 50 °C. Chloroform-heptane (29:21) (2 ml) and fresh copper reagent (Mtriethanolamine-M acetic acetate-6.8% $\text{CuSO}_4 \cdot 5\text{H}_2\text{O}$) solution (9:1:10) (0.5 ml) was added to this residue. The solution was shaken vigorously for 3 min and centrifuged at 3000 rpm for 5 min. A portion (1.6 ml) of the organic phase was evaporated to dryness and 1% ammonium diethyldithiocarbamate solution in isobutylmethyl ketone (2 ml) was added to the residue to form a yellow copper complex. The copper in the solution was determined by atomic absorption spectrophotometry at 324.8 nm (air-acetylene flame). Palmitic acid was used to prepare a calibration graph. The standard deviation for samples containing 30 $\mu\text{g/l}$ of free fatty acids (as palmitic acid) was ± 1 $\mu\text{g/l}$.

9.5.5

Diffusion Method

Xiao et al. [131] determined nanomolar quantities of individual low-molecular-weight carboxylic acids (and amines) in sea water. This method is based on the diffusion of acids across a hydrophobic membrane to concentrate them and separate them from inorganic salts and most other dissolved organic

compounds. Acetic, propionic, butyric, valeric, pyruvic, acrylic, and benzoic acids were all found in measurable amounts in sea water.

9.6

Ketones and Aldehydes

9.6.1

Spectrophotometric Method, Fluorometric and Chemiluminescence Methods

A spectrophotometric method for aldehydes in either fresh or seawater was described by Kamata [132]. It used the colour-forming reaction between the aldehyde, 3-methyl-2-benzothiazolone hydrazone, and ferric chloride, and claimed a sensitivity of 0.01 mg/l as formaldehyde equivalents. While Kamata clearly found evidence of the presence of aldehydes, the method appears to be not quite sensitive enough for the quantities to be found in seawater.

Eberhardt and Sieburth [133] also devised a spectrophotometric procedure for the determination of aldehydes in seawater. The method is based on the reaction of aldehydes with 3-methyl-2-benzothiazolinone, hydrazone hydrochloride, and ferric chloride to produce a coloured compound. A detection limit of 0.072 μM formaldehyde per litre was obtained using a 5 cm path-length.

Automated colorimetric and fluorometric methods for aldehydes were proposed by Afghan et al. [134]. The colorimetric method used chromatotropic acid, while the fluorometric method was based on the reaction between formaldehyde, 2,4-pentadione, and ammonia. The sensitivities of these methods were about the same as that of the Kamata method; they could be employed usefully in fresh water, but were marginal for seawater. A more sensitive version of the fluorometric method for formaldehyde was developed by Zika [135] using the reaction as described by Belman [136]. This version had a sensitivity of 1×10^{-7} M in sea water.

A continuous flow system utilising the oxidation of formaldehyde and gallic acid with alkaline hydrogen peroxide to produce a chemiluminescence was studied by Slawinska and Slawinski [137]. While the major peak of the chemiluminescence spectrum occurred at 635 nm, the photomultiplier used summed all of the available light between 560 and 850 nm. The intensity of the chemiluminescence was linearly proportional to formaldehyde concentration from 10^{-7} to 10^{-2} M, producing a detection limit of 1 $\mu\text{g/l}$. This method should be sensitive enough for use in seawater.

9.6.2

Potential Sweep Voltammetry

Another fresh-water method which holds some promise for seawater analysis is twin cell potential sweep voltammetry, as proposed Afghan et al. [138]. In this method, semicarbazones are formed by reaction with semicarbazide

hydrochloride, and the peak height of the semicarbazones polarogram is then measured. The shape of the polarographic peak is an indication of the type of compound present. The detection limit of this method is 1×10^{-8} M, and the effective range runs from 10^{-8} to 10^{-4} M.

9.6.3

Gas Chromatography

For those aldehydes and ketones which are volatile enough, gas chromatography of the headspace gases can be used, and this has been used to measure acetone, butyraldehyde, and 2-butanone in oceanic waters. In a gas chromatography-mass spectrometry analysis of a single sample of volatile materials concentrated from inshore waters onto Tenax GC, MacKinnon [139] reported tentative identification of methyl isopropyl ketone, bromoform, 4-methyl-2-pentanone, 2-hexanone, and 2-hexanal.

Corwen [140] used dynamic purge and trap analysis to determine ketones and aldehydes (acetone, butyraldehyde, and 2-butanone) in seawater.

9.7

Phenols

9.7.1

Spectrophotometric Methods

While the major emphasis in the analysis of phenols in seawater has been on those compounds introduced by industrial processes, as much phenolic material is probably added by the disintegration of fixed algae in the intertidal regions. A high value for total phenols, particularly in coastal waters, cannot be interpreted simply as a high degree of industrial pollution; the kinds of phenols present must also be ascertained.

A number of colorimetric methods for phenols in seawater have been reported. Alekseeva [141] oxidised the phenols to antipyrene dyes, then extracted the dyes into an organic solvent of considerably smaller volume. The reported detection limit of the method was $20 \mu\text{g/l}$, with a linear range of $20\text{--}80 \mu\text{g/l}$. Goulden [142] used an automated system with steam distillation of the phenols from acidic solution, followed by formation of a coloured derivative and extraction of the derivative into an organic solvent for the final determination. Both 4-amino-antipyrene and 3-methyl-2-benzothiazolinone were evaluated as reagents, with a detection limit of $0.2 \mu\text{g/l}$ for either reagent. Nitroaniline was used as the colorimetric reagent by Schlungbaum and Behling [143], while Stilinovic et al. [144] used both nitroaniline and 4-aminoantipyrene, and Gales [145] modified the 3-methylbenzothiazolinone method to lower the detection limit to $1 \mu\text{g/l}$.

Phenolic substances can be measured directly, without colour development, by the difference in their ultraviolet absorption in acidic and basic

solution [146]. Interference due to the ultraviolet absorption of non-ionising nonphenolic organic species is cancelled out by this difference method. The method was adapted for natural fresh waters by Fontaine et al. [147] with the use of two sealed hollow cathode lamps to monitor the difference spectrum. Comparison with the 4-aminoantipyrine colorimetric method generally showed higher values for the ultraviolet difference method, probably due to the presence of some para-blocked phenols, which will not react in the colorimetric procedure. A simple photometric difference instrument has been developed with a range of 100 $\mu\text{g/l}$ full scale.

9.7.2

Gas Chromatography–Mass Spectrometry (GC–MS)

Boyd [148] determined ppq levels of phenols, cresols, and catechols in San Diego Bay (CA, USA) water by aqueous acetylation of the sample followed by gas chromatography–mass spectrometry.

9.8

Phthalate Esters

Among the most ubiquitous of man's contributions to the environment are the phthalate esters. These compounds are used extensively in the plastics industry and have been found in both fresh and seawater at concentrations in the $\mu\text{g/l}$ range. The usual method of analysis at this level of concentration is gas chromatography; some form of concentration, usually adsorption on a column, is always needed, and great care is required to keep the background levels sufficiently low. Methods of collection, storage, and analysis have been described [149–151]. The use of coupled gas chromatography–mass spectrometry as well as liquid chromatography was discussed by Hites [152].

9.9

Carbohydrates

Of all the classes of organic material to be found in seawater, the carbohydrates are probably the most widely investigated. This is partly because of their role in photosynthesis and their function as storage and structural compounds in algae. Concentrations as low as a few $\mu\text{g/l}$ are of significance.

9.9.1

Spectrophotometry

The early methods were all spectrophotometric and were usually based on the condensation of carbohydrates with a concentrated acid, usually sulfuric, followed by reaction of the condensed product with some colour-forming

compound including *N*-ethylcarbazole, anthrone [153], phenol, orcinol, and tryptophan [154].

Some comparative studies of these methods have been made: anthrone and *N*-ethylcarbazole were compared by Lewis and Rakestraw [153] and by Collier [155], and anthrone, phenol, orcinol and *N*-ethylcarbazole and L-tryptophan were examined by Josefsson et al. [156]. In general, the comparative studies show anthrone to be more reliable than *N*-ethylcarbazole, although somewhat less sensitive. However, Josefsson and co-workers [154] found that of the five methods, the tryptophan method gave the best results when adapted to automatic analysis, and was capable of analysis at concentrations of interest in seawater analysis, i.e., $\mu\text{g/l}$ levels.

The acid condensation methods do not distinguish between monosaccharides and polysaccharides, as the various classes of carbohydrates each have different absorption maxima, which results in different molar absorptions at any chosen wavelength. Furthermore, when treated with concentrated sulfuric acid, some three- and four-carbon compounds will condense into structures which will produce colours with those reagents. When the object of the analysis is to obtain some estimate of the total amount of carbohydrate or carbohydrate-like material present, the inclusiveness of these methods is useful. However, when the object is to distinguish between the easily metabolised simple sugars and the complex storage and structural materials, these methods give no information at all.

A spectrophotometric method that does not use condensation with sulfuric acid was proposed by Mopper and Gindler [157]. The method used the copper (I) complex with 2,2-bicinchoninate to form a colour with simple sugars, with a hydrolysis step which is included to make simple sugars from the polysaccharides. Thus the analysis of two aliquots, one of them hydrolysed, would yield values for both simple and combined sugars.

Another spectrophotometric method measuring both simple and combined sugars was described in papers by Johnson and Sieburth [158] and Burney and Sieburth [159]. The basic method comprised reduction of sugars to alditols with sodium borohydride, and oxidation of the alditols to form free formaldehyde. The formaldehyde was then determined spectrophotometrically with 3-methyl-2-benzothiazolinone hydrazone hydrochloride.

In the determination of carbohydrates, sensitivity can often be increased by using fluorescence rather than absorbance for the final determination. With compounds that are not normally fluorescent, it becomes necessary to find fluorescent derivatives. Hirayama [160] concentrated the carbohydrates in coastal water samples, using electro dialysis and evaporation, and made fluorescent derivatives using anthrone and 5-hydroxyl-1-tetralone, determining pentoses separately from hexoses in the process. While this method does seem to have the extra sensitivity expected from fluorescent methods, the extra manipulations render it unsatisfactory for routine use.

The methods discussed above are all class reactions, designed to estimate the total amount of carbohydrate present and usually actually furnishing some sort of weighted average, weighted by the unequal responses of the different classes of sugars. There are a few methods that are specific for a single class of carbohydrates or for a single sugar. It has long been suspected that uronic acids make up a considerable portion of the dissolved organic carbon in the ocean, but most of the carbohydrate methods do not measure these acids. Williams et al. [161] and Mopper [162] developed a modification of the acidic decarboxylation method of Lefevre and Tollens, and found uronic acids in phytoplankton and in particulate organic carbon.

9.9.2

Enzymic Methods

Enzymic methods are usually very specific and sensitive. Unfortunately the only methods in the literature for carbohydrates are all for glucose. Hicks and Carey [163] reported such a method, with a fluorometric final measurement, which was down to 3×10^{-8} M. Andrews and Williams [164] used a preconcentration step, sorption onto charcoal, elution, and a final determination with glucose oxidase.

9.9.3

Liquid Chromatography

Chromatographic techniques are required to distinguish between the different classes of carbohydrates. Chromatographic methods for both fresh and seawater are described by Whittaker and Vallentyne [165], Degens et al. [166], and Starikova and Yablokova [167, 168]. These methods often include a hydrolysis step to permit the measurement of the monomers held in polysaccharides. A discussion of these methods, together with a comparison between paper chromatographic, colorimetric, and enzymatic methods can be found in Geller [169]. Josefsson [170] recommended a separation by liquid chromatography after desalting by ion exchange membrane electro dialysis. The electro dialysis cell used had a sample volume of 430 ml and an effective membrane-surface area of 52 cm². Perinaplex A-20 and C-20 ion exchange membranes were used. The water-cooled carbon electrodes were operated at up to 250 mA and 500 V. The desalting procedure normally took less than 30 hours. After the desalting, the samples were evaporated nearly to dryness at 40 °C in vacuo, then taken up in 2 ml of 85% ethanol, and the solution was subjected to chromatography on anion exchange resins (sulfate form) with 85% ethanol as mobile phase. By this procedure, it was possible to determine eight monosaccharides in the range 0.15–46.5 µg/l with errors of less than 10%, and to detect traces of sorbose, fucose, sucrose, diethylene glycol, and glycerol in seawater.

Larsson and Degens [171] devised an automated system for determining carbohydrates in biological samples using partition chromatography for the separation and the orcinol colorimetric method for the final analysis. Later versions of this kind of autoanalyser, using tetrazolium blue or a Cu^{I} complex of bicinchoninate for the final measurement, have been reported [172].

9.9.4

Gas Chromatography

The discovery of the usefulness of the trimethylsilyl derivatives for the gas chromatography of a sample was a major step forward in the analysis of complex mixtures.

Such methods, usually also including a hydrolysis step to break down polysaccharides, have been described by Modzeleski et al. [173] and Tesarik [174].

Eklund [175] developed a method for sensitive gas chromatographic analysis of monosaccharides in seawater, using trifluoroacetyl derivatisation and electron capture detection. It is difficult to determine accurately the monosaccharide concentration by this method because a number of chromatographic peaks result from each monosaccharide.

9.9.5

Miscellaneous

Williams [176] has studied the rate of oxidation of C-labelled glucose in seawater by persulfate. After the oxidation, carbon dioxide was blown off and residual activity was measured. For glucose concentrations of 2000, 200, and 20 $\mu\text{g/l}$, residual radioactivities (as percentage of total original radioactivity) were 0.04, 0.05, and 0.025, respectively, showing that biochemical compounds are extensively oxidised by persulfate. With the exception of change of temperature, modifications of conditions had little or no effect. Oxidation for 2.5 h at 100 °C was the most efficient.

While there appears to be a profusion of methods for the analysis of carbohydrates in seawater, a study of the actual capabilities of the methods soon reveals that few of them furnish us with much useful information. At the moment only the methods of Johnson and Sieburth [158] and Burney and Sieburth [159], and the bicinchoninate method of Mopper and Gindler [157], furnish any real estimate of the total amount of carbohydrate present in seawater. For the analysis of the separate sugars, liquid chromatography of carbohydrate derivatives would seem to be the obvious choice. Several methods of determining carbohydrates have been described [177–184].

9.10

Cationic Surfactants

9.10.1

Titration Method

Wang and Pek [185] have described a simple titration method applicable to the analysis of cationic surfactants in sea water. Methyl orange and azure A were used as primary dye and secondary dye, respectively. The method is free from interference by high levels of inorganic salts in sea water.

9.10.2

Atomic Absorption Spectrometry (AAS)

Le Bihan and Courtot-Coupez [186] analysed fresh water for cationic detergents by a method based on atomic absorption spectrometry of the copper–detergent complex.

9.10.3

Gas Chromatography–Mass Spectrometry (GC–MS)

Hon-Nami and Hanya [187, 188] used chloroform extraction to extract linear alkyl benzene sulfates from seawater prior to analysis by GC–MS.

Riu et al. [542] has reported the determination of linear ethyl benzene-sulfates in coastal waters using automated solid-phase extraction followed by capillary electrophoresis with ultraviolet detection, and confirmed by capillary electrophoresis-mass spectrometry. The detection limits were 1 µg/l when 250 ml of coastal water was preconcentrated.

9.11

Anionic Surfactants

There are two different classes of surface-active materials in seawater, those that are naturally present and those that have been added to the oceans by man's activities. Most of the analytical methods proposed for use in seawater actually measure the anthropogenic input, and attempt as much as possible to eliminate interferences from naturally occurring compounds. Yet sea foam was known to exist long before detergents. It is to be expected that both kinds of surfactants would be concentrated at the air–sea interface.

9.11.1

Titration

Titration methods are often used as alternatives to the spectrophotometric methods. Wang et al. [189] determined anionic surfactants by adding an ex-

cess of cationic surfactant, acidifying, and then titrating with standard sodium tetraphenylboron. The method was adapted for seawater by the same authors [190], and a simplified field kit was described.

9.11.2

Spectrophotometry

The spectrophotometric methylene blue method for anionic surfactants has been applied to seawater. In one version, the surfactants are collected in ethyl acetate. The solvent is then evaporated, the surfactants put back in solution in water, and the standard spectrophotometric methylene blue method is applied to this solution. In this manner, the salt error introduced by seawater is eliminated [195]. A similar method, with the methylene blue-surfactant complex extracted into chloroform, and measured directly was proposed by Hagihara [192].

A method using azure A instead of methylene blue has been proposed by Den Tankelaar and Bergshoeff [193]. Workers at the Water Research Centre [194] described a methylene-blue based autoanalysis method for determining 0–1 $\mu\text{g/l}$ anionic detergents in water and sewage effluents. This method was based on work of Longwell and Maniece [195], and subsequently modified by Abbott [196] and by Sodergren [197]. The Water Research Centre report describes the method in detail and discusses its precision and accuracy.

Favretto and Tunis [198] extracted polyoxyethylene alkyl phenyl ethers as picrates into an organic solvent, complexed the polymer with sodium ion, and measured the absorption complex. This is one of the few specific methods available.

Bhat et al. [199] used complexation with the bis(ethylenediamine) copper (II) cation as the basis of a method for estimating anionic surfactants in fresh estuarine and seawater samples. The complex is extracted into chloroform, and copper is measured spectrophotometrically in the extract using 1,2(pyridyl azo)-2-naphthol. Using the same extraction system these workers were able to improve the detection limit of the method to 5 $\mu\text{g/l}$ (as linear alkyl sulfonic acid) in fresh estuarine and seawater samples.

9.11.3

Atomic Absorption Spectrometry (AAS)

A rough estimate of the total amount of anionic surfactant present can be obtained by reacting the surfactant with a metal-containing material such as bis(ethylene diamine) copper (II) [199, 200, 203], or *o*-phenanthroline- CuSO_4 , extracting the complex into an organic solvent (209 MIBK), and determining the metal by atomic absorption.

Le Bihan and Courtot-Coupez [202] used the copper complex and flameless atomic absorption spectroscopy to determine anionic detergents. Crisp [200]

was the first to use the bis(ethylenediamine) Cu^{II} ion for the determination of anionic detergents. These workers determine the concentration of detergents by flame atomic absorption spectroscopy or by a colorimetric method. The colorimetric method was more sensitive, with a limit of detection of $0.03 \mu\text{g/l}$ (as linear alkyl sulfonic acid) compared with $0.06 \mu\text{g/l}$ for atomic absorption spectroscopy. Crisp et al. [204] determined anionic detergents in fresh estuarine and seawater at the ppb level. The detergent anions in a 750 ml water sample are extracted with chloroform as an ion association compound with the bis(ethylene-diamine) copper (II) cation, and determined by atomic absorption spectrometry using a graphite furnace atomiser. The limit of detection (as linear alkyl sulfonic acids) is $2 \mu\text{g/l}$.

Gagnon [203] has described a rapid and sensitive AAS method developed from the work of Crisp et al. [200] for the determination of anionic detergents at the ppb level in natural waters. The method is based on determination by atomic absorption spectrometry using the bis(ethylene-diamine) copper (II) ion. The method is suitable for detergent concentrations up to $50 \mu\text{g/l}$ but it can be extended up to $15 \mu\text{g/l}$. The limit of detection is $0.3 \mu\text{g/l}$.

The recovery of different concentrations of detergents added to seawater was used to evaluate the accuracy of the method. The recovery is 80% at $1 \mu\text{g/l}$ but reaches 90% at $10 \mu\text{g/l}$. The recovery is 97% or better at higher concentrations. Precision was very good.

9.11.4

High-Performance Liquid Chromatography (HPLC)

The methylene blue reaction can also be used in a fractionation procedure for surfactants. The complexes with methylene blue can be collected in an organic solvent, concentrated, dissolved in methanol, and separated by high-performance liquid chromatography [205]. A variation of this method, permitting the collection of surfactant from large volumes of sample, should be workable in seawater.

9.12

Non-ionic Surfactants

9.12.1

Spectrophotometry

Favretto and co-workers [198, 206–208] have described direct spectrophotometric methods for non-ionic surfactants based on the formation of a sodium picrate surfactant adduct. This method has been applied to seawater. A mean value of $93 \pm 1\%$ was obtained in recovery experiments on C_{12}E_9 (at an aqueous concentration of 0.10 mg/l) extracted from synthetic sea water by means of this

procedure. Therefore, a multiplication factor of 1.07 was adopted in correcting for the extraction losses.

9.12.2

Atomic Absorption Spectrometry (AAS)

Courtot-Coupez and Le Bihan [209, 210] determined non-ionic detergents in sea- and fresh-water samples at concentrations down to 2 $\mu\text{g/l}$ ppm by benzene extraction of the tetrathiocyanatocobaltate (II) $(\text{NH}_4)_2(\text{Co}(\text{SCN})_4)$ [182] detergent ion-pair, followed by atomic absorption spectrophotometric determination of cobalt [209].

Courtot-Coupez and Le Bihan [209, 210] determined the optimum pH (7.4) for extraction of non-ionic surfactants with the above complex-benzene system. Cobalt in the extract is estimated by AAS after evaporation to dryness and dissolution of the residue in methyl isobutyl ketone. The method is applicable to surfactant concentrations in the range 0.02–0.5 mg/l and is not seriously affected by the presence of anionic surfactants.

Crisp et al. [212] has described a method for the determination of non-ionic detergent concentrations between 0.05 and 2 mg/l in fresh, estuarine, and sea-water based on solvent extraction of the detergent–potassium tetrathiocyanatozincate (II) complex followed by determination of extracted zinc by atomic AAS. A method is described for the determination of non-ionic surfactants in the concentration range 0.05–2 mg/l. Surfactant molecules are extracted into 1,2-dichlorobenzene as a neutral adduct with potassium tetrathiocyanatozincate (II), and the determination is completed by AAS. With a 150 ml water sample the limit of detection is 0.03 mg/l (as Triton X-100). The method is relatively free from interference by anionic surfactants; the presence of up to 5 mg/l of anionic surfactant introduces an error of no more than 0.07 mg/l (as Triton X-100) in the apparent non-ionic surfactant concentration. The performance of this method in the presence of anionic surfactants is of special importance, since most natural samples which contain non-ionic surfactants also contain anionic surfactants. Soaps, such as sodium stearate, do not interfere with the recovery of Triton X-100 (1 mg/l) when present at the same concentration (i.e., mg/l). Cationic surfactants, however, form extractable non-association compounds with the tetrathiocyanatozincate ion and interfere with the method.

9.12.3

Liquid Chromatography–Mass Spectrometry (LC–MS)

Reversed phase liquid chromatography–mass spectrometry was applied to extracts of Jamaica Bay (New York) water to determine 1–300 $\mu\text{g/l}$ amounts of nonyl phenol ethoxylates and their metabolites [213].

9.13 Aliphatic Chloro Compounds

9.13.1 Gas Chromatography

Eklund et al. [214, 215] has developed a capillary column method [216, 217] for the determination of down to $1\ \mu\text{g/l}$ volatile organohalides in waters that combines the resolving power of the glass capillary column with the sensitivity of the electron capture detector. The eluate from the column is mixed with purge gas of the detector to minimise band broadening due to dead volumes. This and low column bleeding give enhanced sensitivity. Ten different organohalides were quantified in seawater. Using this technique these workers detected bromoform in seawater for the first time.

Halogenated hydrocarbons in different waters were identified by comparison with a standard solution. A chromatogram of a standard pentane solution of various volatile organochlorine compounds including trihaloforms is shown in Fig. 9.1. Retention times were measured on two columns with different stationary phases (SE-52 and Carbowax 400).

The approximate detection limits of the method range from $1\ \text{fg}\ \text{CCl}_4$ to $500\ \text{fg}\ \text{CH}_2\text{CCl}_2$.

9.13.2 Purge and Trap Analysis

Kaiser and Oliver [218] applied dynamic purge and trap analysis to determine halocarbons in seawater.

The Bellar et al. [219] purge and trap method has been applied to the determination of vinyl chloride in seawater. Using the Hall electrolytic conductivity detector, no response was obtained for the acetone used to prepare the vinyl chloride standard solution.

Organic compounds are extracted from the charcoal with a small volume of a suitable solvent such as carbon disulfide or dichloromethane, then collected and injected into a capillary gas chromatograph or a capillary gas chromatograph coupled with a mass spectrometer.

Grob et al. [220–223] have carried out very detailed and systematic studies of the closed-loop gas stripping procedure and applied it to the determination of $\mu\text{g/l}$ of 1-chloroalkanes in water. Westerdorf [224] applied the technique to chlorinated organics, and aromatic and aliphatic hydrocarbons. Waggot and Reid [225] reported that a factor of major concern in adapting the technique to more polluted samples is the capacity of the carbon filter, which usually contains only $1.5\text{--}2\ \text{mg}$ carbon. They showed that the absolute capacity of such a filter for a homologous series of 1-chloro-*n*-alkanes was $6\ \mu\text{g}$ for complete recovery.

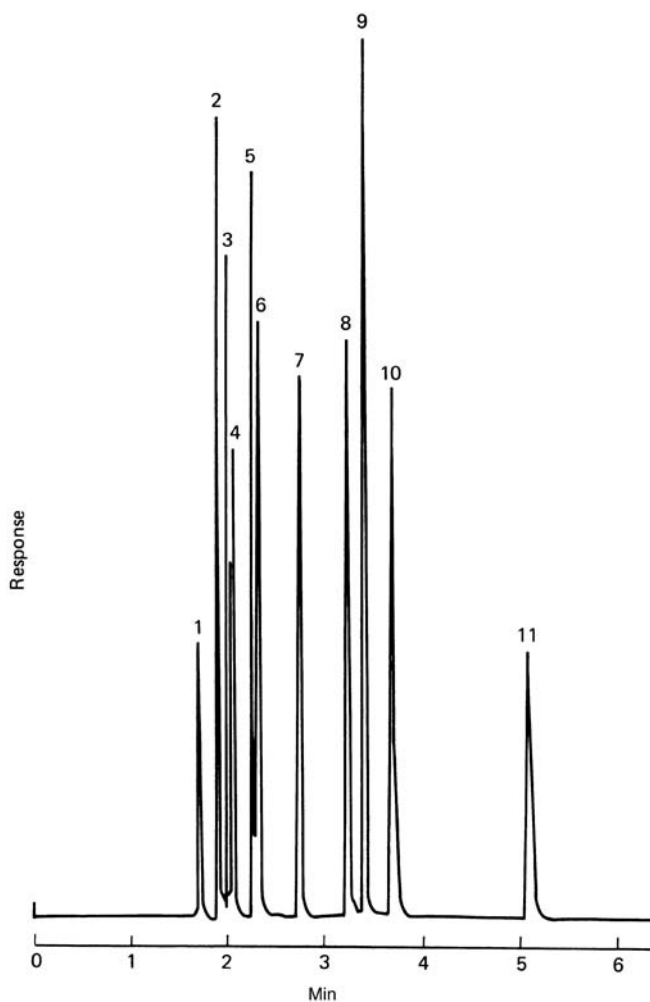

Figure 9.1. Chromatogram of a standard mixture containing 11 organohalides. Stationary phase, SE-52; 33 m \times 0.3 mm id, injection temperature 200 °C, column temperature 50 °C, interface 250 °C, detector temperature 250 °C. Helium carrier gas flow rate 36 ml/s, scavenger gas flow 30 ml/min. Split ratio 1.20. 1 CH_2Cl_2 2 CHCl_3 3 CH_3CCl_2 4 CCl_4 5 CHClCCl_2 6 CHBrCl_2 7 CBrCl_3 8 CHBr_2Cl 9 CCl_2CCl_2 10 CHCl_2I 11 CHBr_3 . Source: [215]

9.13.3 Head Space Analysis

Trichlorofluoromethane and dichlorofluoromethane have been determined in seawater using headspace analysis and gas chromatography with electron capture detection [226].

9.13.4

Miscellaneous

Dawson et al. [227] described samplers for large-volume collection of sea water samples for chlorinated hydrocarbon analyses. The samplers use the macroreticular absorbent Amberlite XAD-2. Operation of the towed "fish" type sampler causes minimal interruption to a ship's programme and allows a large area to be surveyed. The second type is a self-powered in situ pump which can be left unattended to extract large volumes of water at a fixed station.

Lovelock and co-workers [228, 229] determined methyl fluoride, methyl chloride, methyl bromide, methyl iodide, and carbon tetrachloride in the Atlantic Ocean. This shows a global distribution of these compounds. Murray and Riley [230, 231] confirmed the presence of carbon tetrachloride, and also found low concentrations of chloroform and tri- and tetrachloroethylene in Atlantic surface waters.

Kristiansen et al. [232] identified halogenated hydrocarbon byproducts in chlorinated seawater.

9.14

Volatile Organic Compounds

9.14.1

Head Space Analysis

There have been many applications of the technique [233–240]. The major advantage of the headspace method is simplicity in handling the materials. At most, only one chemical, the salt used in the salting-out procedure, needs to be added, and in most cases the headspace gas can be injected directly into a gas chromatograph or carbon analyser. On the other hand, the concentration of organic materials present is limited by the volume of sea water in the sample bottle. This is very much a batch process. Equilibration between the headspace gas and the solution can take a considerable time. This is not a problem when the salting-out material is added at sea, and the samples are then brought into the laboratory for analysis some time later. When the salting-out is done in the laboratory, equilibration can be hastened by recirculating the headspace gas through the solution. A system could be devised which would permit the accumulation of volatiles from a large volume of water into a relatively small headspace, perhaps by recirculating both water and headspace gas through a bubbling and collection chamber, but much of the simplicity and freedom from possible contamination would be lost in the process.

Volatile organic materials can also be removed from solution by distillation, either at normal or at elevated pressures. While the amounts to be collected in this fashion are small, if headspace samples are taken at elevated temperatures and pressures, trace quantities of organics can be collected. It should

be emphasised, however, that whenever extreme conditions are employed to free an organic fraction, that fraction is defined by the conditions of the separation and cannot profitably be compared with fractions defined by different sampling conditions. The use of elevated temperatures and pressures may also alter the compounds separated, limiting the amount of information that can be extracted from the analyses.

9.14.2

Stripping Methods

Juettner [242] has studied the application of stripping methods to the determination of volatile organic compounds in seawater.

9.14.3

Mass Spectrometry

Kasthurikrishnan et al. [243] used membrane mass spectrometry to study the analysis of volatile organic compounds in seawater at ppt concentrations.

9.15

Chlorinated Dioxins

Hashimoto et al. collected chlorinated dioxins and furans at concentrations of 1 ppq in seawater on a XAD-2 column [244].

9.16

Nitrogen Compounds

Simply on the basis of the normal composition of marine organisms, we would expect proteins and peptides to be normal constituents of the dissolved organic carbon in seawater. While free amino acids might be expected as products of enzymic hydrolysis of proteins, the rapid uptake of these compounds by bacteria would lead us to expect that free amino acids would normally constitute a minor part of the dissolved organic pool. This is precisely what we do find; the concentration of free amino acids seldom exceeds 150 $\mu\text{g/l}$ in the open ocean. It would be expected that the concentration of combined amino acids would be many times as great. There have been relatively few measurements of proteins and peptides, and most of the measurements were obtained by measuring the free amino acids before and after a hydrolysis step. Representative methods of this type have been described [245–259]. Since these methods are basically free amino acid methods, they will be discussed next in conjunction with those methods.

Free Amino Acids

Although the free amino acids are present only at very low concentrations in oceanic waters, their importance in most biological systems has led to an inordinate amount of effort toward their determination in seawater. A sensitive, simple, and easily automated method of analysis, the colorimetric ninhydrin reaction, has been known in biochemical research for many years. In order for the method to be useful in seawater, the amino acids had to be concentrated. This concentration was usually achieved by some form of ion exchange [251]. An automated method not using a concentration step was developed by Coughenower and Curl [252]. While the method was used successfully in Lake Washington, its limit of detection ($0.5 \mu\text{mol/l}$) is just too great for most oceanic samples.

9.16.1

Spectrofluorometry

Various workers have discussed the application of this technique [164, 253–257], employing ninhydrin [218] and *o*-phthaldehyde as fluorescing agents [257].

Amino acid analysers based on ion exchange resins are available commercially. These achieve good separations of amino acid mixtures. Fluorescent derivatives of separated amino acids constitute a very sensitive means of detecting these compounds in seawater [256, 258]. Fluorescent derivatives that have been studied include *o*-phthalaldehyde [259], dansyl [260], fluorescamine [261], and ninhydrin [261].

The amino acid analyser using fluorescamine as the detecting reagent has been used to measure 250 picomoles of individual amino acids routinely [262], and dansyl derivatives have been detected fluorometrically at the 10^{-15} M level [260]. Where the amounts of amino acid are high enough, the fluorescamine method, with no concentration step, can be recommended for its simplicity. At lower concentrations, the dansyl method, with an extraction of the fluorescent derivatives into a non-polar solvent, should be more sensitive and less subject to interferences. For proteins and peptides, the fluorescamine method seems to be the most sensitive available method.

In this connection, it is interesting to note that Gardner [263] isolated free amino acids at the 20 nmol/l level from as little as 5 ml of sample by cation exchange, and measured concentrations on a sensitive amino acid analyser equipped with a fluorometric detector.

The classic work of Dawson and Pritchard [264] on the determination of α -amino acids in seawater uses a standard amino acid analyser modified to incorporate a fluorometric detection system. In this method the seawater samples are desalinated on cation exchange resins and concentrated prior to analysis. The output of the fluorometer is fed through a potential divider and low-pass filter to a comparison recorder.

Dawson and Pritchard [264] point out that all procedures used for concentrating organic components from seawater, however mild and uncontaminating, are open to criticism simply because of the ignorance as to the nature of these components in seawater. It is, for instance, feasible that during the process of desalination on ion exchange resins under weakly acidic conditions, metal chelates are dissociated and thereby larger quantities of "free" components are released and analysed.

An example of a chromatogram obtained from a seawater sample and the mole percentage of each amino acid in the sample is depicted in Fig. 9.2.

Mopper [265] has described developments in the reverse phase performance liquid chromatographic determination of amino acids in seawater. He describes the development of a simple, highly sensitive procedure based on the conversion of dissolved free amino acids to highly fluorescent, moderately hydrophobic isoindoles by a derivatisation reaction with excess *o*-phthalaldehyde and a thiol, directly in seawater. Reacted seawater samples were injected without further treatment into a reverse-phase high-performance liquid chromato-

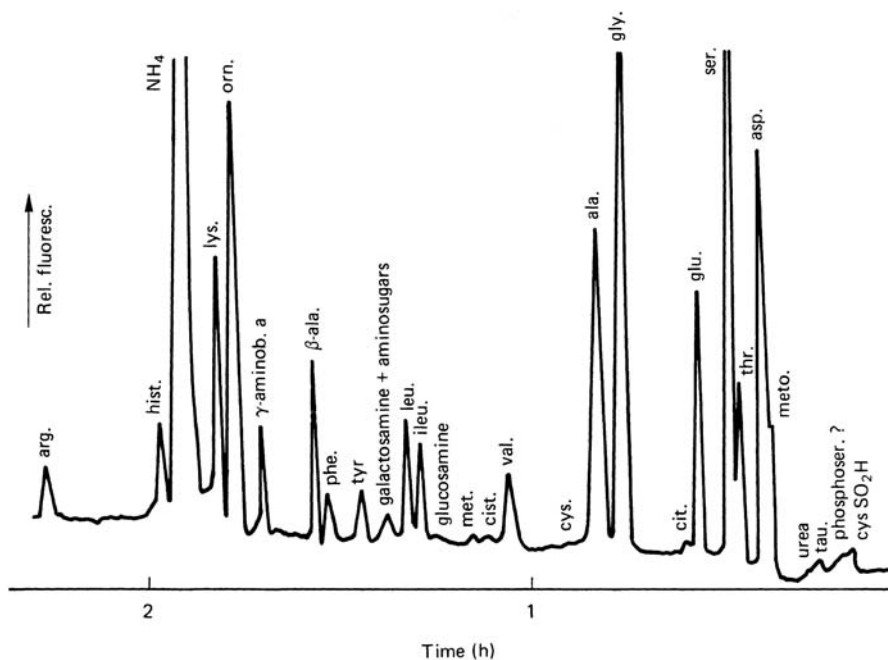

Figure 9.2. Chromatogram of a seawater extract (20 ml) sample for amino acids collected at 6 m in the Kiel Fjord. The concentrations of the individual acids were quantified as follows (in nmol/l): meto, 11; asp 34.4; thr, 23.2; ser, 88; glu, 36; gly, 100; ala, 56; val, 16; ileu, 9.6; leu, 12; galactosamine and amino sugars, 4; tyr, 6.8; phe, 7.2; B-ala, 20.8; α -amino- γ , 14.4; orn, 44; lys, 12; hist, 7.2; arg, 8.6; cysSO₂H, 4; cit, trace; tan, cys, trace; glucose-amine, trace; met, trace; urea, trace; phosphoserine, trace; OH-lys, trace. The total concentration of amino acid in the sample lies around 51 μ g/l, assuming a mean molecular weight of 100. Source: [264]

graphic column, followed by a gradient elution. The eluted amino acid derivatives were detected fluorometrically. Detection limit for most amino acids was 0.1–0.2 nmol per 500 μ l injection. Problems of inadequacies with the method itself, sample handling, and whether chromatographically determined concentrations might be considered as biologically available concentrations in seawater, are discussed.

Chromatographic Methods

Several of the earlier methods used paper chromatography for the final separation and determination, after some concentration step. Starikova and Korzhikova [248] concentrated the free amino acids by taking the acidified solutions to dryness, then extracting the sea salts with 80% ethanol. Riley and Segar [246] dropped the detection limit to 0.1 μ g/l, using TLC. Litchfield and Prescott [258] made dansyl derivatives, extracted these into an organic solvent, and then separated the amino acids by TLC. Ligand exchange was used as a concentrating mechanism by Clark et al. [266] followed by TLC for final separation. The formation of 2,4-dinitro-1-fluorobenzene derivatives, followed by solvent extraction of these derivatives and circular TLC was suggested by Palmork [267].

Ligand exchange has been a favoured method for the concentration of amino acids from solution because of its selectivity [268]. Ion exchange has often then been used for the final separation of the acids [269–272].

Other methods of concentration have also been used to bring the levels of amino acids into a range suitable for ion exchange chromatography. Bohling [273, 274] and Garrasi and Degens [275] used evaporation or freeze drying, followed by extraction of dried salts with organic solvents. Tatsumoto et al. [276] used coprecipitation with ferric hydroxide as the method of concentration prior to ion exchange chromatography.

Pocklington [277] has separated amino acids in seawater using freeze drying. The first step in his concentration of free acids from seawater was the freeze drying of the seawater samples. To reduce interferences in the later steps of the procedure, the sea salts were packed into a chromatographic column and washed with diethyl ether to remove non-polar compounds. The diethyl ether extract, particularly from surface water samples, quite often contained coloured materials as well as other organics. If a series of solvents of graduated polarity were passed through a sea salt column, a fractionation by polarity should be obtained. With the proper choice of solvents, a form of gradient elution could be devised which would result in a continuous rather than a batch fractionation.

Gas Chromatography

Since the amino acids are not volatile, derivatives that are both volatile and easily synthesised had to be found. A silyl derivative was used by Pockling-

ton [278] after the amino acids had been separated as a group and concentrated by extraction of the freeze-dried sea salts with an organic solvent, followed by evaporation of the solvent.

A still greater increase in sensitivity can often be achieved by using an electron capture detector instead of flame ionisation, if the compound or its derivative contains a halogen atom. Derivatives of this sort had been found for the amino acid analyses; one procedure yielded *n*-butyl *N*-trifluoroacetyl esters [279]. The method has been adapted for seawater and a similar method using the methyl ester was devised by Gardner and Lee [280]. While sufficient sensitivity could be achieved with the use of these techniques there was far too much sample handling in the separation and derivative formation. With the development of easily synthesised fluorescent derivatives, liquid chromatography has largely supplanted gas chromatography for these analyses.

9.16.2

Proteins and Peptides

The older methods for the measurement of protein in natural waters usually depended upon the presence of aromatic amino acids in the protein, and calculated total protein on the basis of an average tyrosine, tryptophan, or phenylalanine content. A method representative of this type was the Folin reagent method published by Debeika et al. [281]. While these methods were useful in fresh water and in some coastal regions, they were not sensitive enough for the lower concentrations to be found in oceanic waters.

A fluorescence method that would measure either free or combined amino acids, depending upon the pH of the solution, was originally proposed by Udenfriend et al. [282] and adapted for seawater by North [283] and Packard and Dortch [284]. In this Fluran method, peptides normally yield maximum fluorescence by pH 7, while amino acids fluoresce best at pH 9. With the proper choice of buffers, the fluorescence of peptides and proteins can be differentiated from that due to free amino acids.

An attempt to use the infrared spectrum of materials collected at the sea surface for a quantitative measure of composition has been made by Baier et al. [285]. They dipped a germanium crystal through the surface film, then ran an internal reflectance spectrum on the material clinging to the crystal. From the spectrum, they concluded that the bulk of the material present in the surface film was there as glycoproteins and proteoglycans.

9.16.3

Nucleic Acids

Pillai and Ganguly [286] have concentrated the nucleic acids from seawater by adsorption on homogeneously precipitated barium sulfate, then hydrolysed with 0.02 M hydrochloric acid and analysed for the constituents.

Hicks and Riley [287] have described a method for determining the natural levels of nucleic acids in lake and seawaters, which involves preconcentration by adsorption onto a hydroxyapatite, elution of the nucleic acids, and then photometric determination of the ribose obtained from them by hydrolysis.

9.16.4

Enzyme Activity

Enzyme activity has been sought in seawater; Strickland and Solorzano [288] looked for photomonoesterase activity, while Maeda and Taga [289] used a fluorometric method for assaying deoxyribonuclease activity in both seawater and sediment samples.

9.16.5

Aliphatic and Aromatic Amines

Aliphatic amines have been determined by a number of methods. Batley et al. [290] extracted the amines into chloroform as ion-association complexes with chromate, then determined the chromium in the complex colorimetrically with diphenylcarbazide. The chromium might also be determined, with fewer steps, by atomic absorption. With the colorimetric method, the limit of detection of a commercial tertiary amine mixture was 15 ppb. The sensitivity was extended to 0.2 ppb by extracting into organic solvent the complex formed by the amine and Eosin Yellow. The concentration of the complex was measured fluorometrically. Gas chromatography, with the separations taking place on a modified carbon black column, was used by Di Corcia and Samperi [291] to measure aliphatic amines.

Varney and Preston [292] discussed the measurement of trace aromatic amines in seawater using high-performance liquid chromatography.

Aniline, methyl aniline, 1-naphthylamine, and diphenylamine at trace levels were determined using this technique and electrochemical detection. Two electrochemical detectors (a thin-layer, dual glassy-carbon electrode cell and a dual porous electrode system) were compared. The electrochemical behavior of the compounds was investigated using hydrodynamic and cyclic voltammetry. Detection limits of 15 and 1.5 nmol/l were achieved using colourimetric and amperometric cells, respectively, when using an in-line preconcentration step.

Petty et al. [293] used flow injection sample processing with fluorescence detection for the determination of total primary amines in sea water. The effects of carrier stream flow rate and dispersion tube length on sensitivity and sampling rates were studied. Relative selective responses of several amino acids and other primary amines were determined using two dispersion tube lengths. Linear calibration curves were obtained over the ranges $0-10^{-6}$ M and

$0-10^{-8}$ M glycine. Precisions of better than 2% at 10^{-6} M and a detection limit of 10^{-8} M glycine were obtained.

Yang et al. [294] determined nanomolar quantities of individual molecular weight amines (and organic acids) in sea water. Amines were diffused from the sample across a hydrophilic membrane to concentrate and separate them from inorganic salts and most other dissolved organic compounds. Methylamine, dimethylamine, and trimethylamine were all found in measurable amounts in sea water.

Florence and Farmer [295] determined parts per million of aliphatic amines in sea water using spectrophotometric procedures.

9.16.6

Nitro-Compounds

The gas chromatographic determination of isomers of dinitrotoluene in seawater has been described by Hashimoto and co-workers [296, 297]. These authors describe the complete separation of six dinitrotoluene isomers using gas chromatography with support-coated open tubular glass capillary columns and electron-capture detection. The method was applied to the qualitative and quantitative analyses of trace levels of isomers in seawater and the results were found to be satisfactory, with no need for further clean-up procedures.

The separation was achieved on an Apiezon L grease SCOT glass capillary column. Complete separation of six dinitrobenzene isomers took 8 min.

The method was used for routine monitoring of dinitrotoluene concentrations in seawater from Dokai Bay, Japan. Both 2,6- and 2,4-dinitrotoluene were detected. Concentrations of 2,4-dinitrotoluene in surface water samples were higher than those in bottom water samples in 8 out of 10 samples.

To detect nitro explosives in seawater Barshick et al. [298] investigated a method based on gas chromatography-ion trap mass spectrometry.

Complex matrixes typically cannot be analysed directly to obtain the selectivity and sensitivity required for most trace analysis applications. To circumvent this problem, solid-phase micro extraction techniques were used to preconcentrate analytes selectively prior to gas chromatography/ion trap mass spectrometry analysis.

The choice of solid-phase microextraction sorbent phase was shown to be important especially for the amino metabolites of trinitrotoluene and RDX, which were extracted better on polar phases. Although equilibration times were quite lengthy, on the order of 30 min or greater, a sampling time of only 10 min was shown to be sufficient for achieving low part-per-billion (ppb) to part-per-trillion (ppt) detection limits for trinitrotoluene and the amino metabolites in real seawater samples. Solid-phase microextraction was ideal for rapid screening of explosives in seawater samples.

9.16.7

Azarenes

Shinohara et al. [299] have described a procedure based on gas chromatography for the determination of traces of two, three, and five-ring azarenes in seawater. The procedure is based on the concentration of the compounds on Amberlite XAD-2 resin, separation by solvent partition [300], and determination by gas chromatography–mass spectrometry with a selective ion monitor. Detection limits by the flame thermionic detector were 0.5–3.0 ng and those by gas chromatography–mass spectrometry were in the range 0.02–0.5 ng. The preferred solvent for elution from the resin was dichloromethane and the recoveries were mainly in the range 89–94%.

Diagram – See Attachment A

9.16.8

Urea

Urea has been of interest to the biological oceanographer because of its role as an excretion product of protein metabolism, its function in osmoregulation, and its reported use as a nitrogen source for phytoplankton growth.

Emmet [301] developed a colorimetric method involving chlorination of the urea with hypochlorite, followed by condensation with phenol. The limit of detection for this method was 0.2 $\mu\text{g/l}$ as nitrogen. The method was easily adaptable to automatic analysis.

Most workers now use a colorimetric method based on the reaction of urea with biacetylmonoxime [302, 303]. The method has been adapted for automated analysis by De Marche et al. [304].

Urea has been determined in seawater, employing the urea diacetyl reaction and spectrophotometry [305].

9.16.9

Hydroxylamine

Von Breymann et al. [306] have described a method for the determination of hydroxylamine in seawater based on gas chromatography with electron capture detection.

9.16.10

Acrylamide

Brown and Rhead [307] improved the sensitivity of high-performance liquid chromatography to 0.2 $\mu\text{g/l}$. This procedure consists of bromination, extraction of the α , β -dibromopropionamide with ethyl acetate, and quantification using high-performance liquid chromatography with ultraviolet detection. Samples

tested included river, sea, and estuarine waters, sewage and china clay works effluents, and potable waters. The levels of inorganic ultraviolet-absorbing impurities found in water samples did not interfere in this procedure. The solvent extraction procedure lowered interferences in all samples tested without removal of acrylamide or excessive use of solvents. The experimental yields of α , β -dibromopropionamide encountered gave a mean of $70.13 \pm 8.52\%$ (95% confidence level) for acrylamide-spiked waters, over the concentration range 0.2–8.0 $\mu\text{g/l}$ of acrylamide monomer.

9.16.11

Ethylene Diamine Tetracetic Acid and Nitriloacetic Acid

Differential pulse polarography has also been used to determine EDTA and nitriloacetic acid in synthetic sea water and phytoplankton media [308]. Cadmium is used to convert a large fraction of either ligand to the reducible cadmium complex. The presence of competing metal cations, including copper, is not detrimental if the method of standard additions is used. The method was used in correlating the concentration of complexed and uncomplexed species of copper with phytoplankton productivity, and production of extracellular metal-binding organic compounds.

9.17

Sulfur Compounds

9.17.1

Alkyl Sulfides and Disulfides

Dimethyl sulfide (DM) is a major volatile organosulfur compound produced in seawater by certain groups of phytoplankton. It has been suggested that the flux of dimethyl sulfide to the marine atmosphere could affect the cloud albedo and therefore the global nuclei environment, via oxidation reactions to form cloud condensation [312]. Due to the significant spatial and temporal variations in the concentration of dimethyl sulfide in seawater [313–316], and hence the flux to the atmosphere, there is a need to fully categorise dimethyl sulfide and its precursors in seawater in order to provide more accurate determinations of the global sulfur cycle, especially for impact on the global climate.

Dimethyl sulfide is derived primarily from the enzymatic hydrolysis of dimethyl sulfoniopropionate ($(\text{CH}_3)_2\text{S}^+\text{CH}_2\text{CH}_2\text{COO}^-$; DMSP), an osmoregulatory compound produced by a wide variety of marine phytoplankton [313,317]. Intracellular DMSP hydrolysis has been shown in phytoplankton [318], in macro algae [319], and also in bacteria following uptake of DMSP from seawater [320]. Reported seawater concentrations of dissolved dimethyl sulfide (< 0.1 –90 nM) and DMSP (1–1000 nM) vary with increasing depth, spatially from coastal areas to the open ocean, and also temporally from winter to summer [313–316].

Gas Chromatography

Dimethyl sulfide (DM) and dimethyl disulfide have been measured in seawater and in the atmosphere by gas chromatography [309] and by GC-MS [310]. Some variety of cryogenic trapping is often used.

Leck and Baagander [311] determined reduced sulfide compounds in seawater by gas chromatography using a flame ionisation detector. Substances determined include methyl mercaptan, dimethyl sulfide, hydrogen sulfide and carbon disulfide. Detection limits range from 0.2 ng/l (carbon disulfide) to 0.6 ng/l (methyl mercaptan).

Smith et al. [321] determined dimethyl sulfide at sea using a purge and trap GC-MS system. This method provides good accuracy and precision for the determination of dimethyl sulfide and its precursor dimethyl sulfoniopropionate (DMSP) in seawater for trials-based equipment. By using deuterated internal standards of DM- d_6 and DMSP- d_6 , the precision for replicate determinations was shown to be as high as 1.6% for dimethyl sulfide and 5.8% for DMSP when the internal standard concentration differed by up to an order of magnitude from the components being determined. The method for DM using "commercial off-the-shelf" equipment gave a detection limit of 0.03 nM and was linear to > 100 nM. The most appropriate sample preparation methodology for storing the samples for up to 56 h during intensive sampling periods included filtration, acidification, and refrigeration.

9.17.2

Thiols

Shea and MacCrehan [322] and Duane and Stock [323] determined hydrophilic thiols in marine sediment pore waters using ion-pair chromatography coupled to electrochemical detection.

9.17.3

Dimethyl Sulfoxide

Andreae [324, 325] has described a gas chromatographic method for the determination of nanogram quantities of dimethyl sulfoxide in natural waters, seawater, and phytoplankton culture waters. The method uses chemical reduction with sodium borohydride to dimethyl sulfide, which is then determined gas-chromatographically using a flame photometric detector.

9.17.4

Thiabend Azole

Capitan et al. [326] determined down to 0.1 ng/l thiabendazole residues in seawater using solid phase spectrophotometry.

9.17.5

Cysteine and Cystine

Cysteine and cystine has been determined in seawater by a method based on cathode stripping voltammetry of the copper complex [327].

9.17.6

Miscellaneous

Turner et al. [328] determined nanogram quantities of dimethyl sulfide and dimethyl sulfoniopropionate in Antarctic waters.

Dimethyl sulfide and other volatile organic compounds have been determined in amounts down to 0.1 pg/l in seawater in a method described by Watanabe et al. [329].

Adsorption on XAD-2 and XAD-4 resins followed by solvent desorption and head space GS has been employed for the preconcentration and determination of volatile organosulfur compounds in estuary and seawater [330].

Savchuk et al. [331] used GC with an open tubular column and a chemiluminescence detector to determine sulfur-containing organic compounds in amounts down to 0.1 ppt in seawater.

9.18

Chlorinated Insecticides

9.18.1

Gas Chromatography

Work on the determination of chlorinated insecticides has been almost exclusively in the area of gas chromatography using different types of detection systems, although a limited amount of work has been carried out using liquid chromatography and thin-layer chromatography.

Wilson and co-workers [332, 333] have discussed the determination of aldrin, chlordane, dieldrin, endrin, lindane, *o,p* and *p,p'* isomers of DDT and its metabolites, mirex, and toxaphene in seawater and molluscs. The US environmental Protection Agency has also published methods for organochlorine pesticides in water and wastewater. The Food and Drug Administration (USA) [334] has conducted a collaborative study of a method for multiple organochlorine insecticides in fish. Earlier work by Wilson et al. [333, 335] in 1968 indicated that organochlorine pesticides were not stable in seawater.

Since petroleum ether was the solvent used in the earlier studies for extracting the DDT from seawater, Wilson and Forester [332] initiated further studies to evaluate the extraction efficiencies of other solvent systems.

The recovery rates of *o,p'*-DDE in all tests were greater than 89% with petroleum ether, or with 15% diethylether in hexane followed by hexane or methylene dichloride, indicating no significant loss during analyses. The average percentage recovery of *p, o'*-DDT extracted from seawater (salinity 16–21 ppt) up to 14 days after initiation of the experiment was in the range 76% to 95%. Immediately after the seawater was fortified with 3.0 ppb of DDT all solvent systems removed 93% of the DDT.

Liquid scintillation counting of (¹⁴C) DDT has been used to study the pick-up and metabolism of DDT by freshwater algae and to determine DDT in seawater [336].

Wilson [337] showed that liquid–liquid extraction of estuarine water immediately after addition of DDT gave acceptable recovery levels with all solvent systems tested, but analyses carried out several days later gave only partial recovery owing to adsorption of DDT on suspended matter.

Aspila et al. [338] reported the results of an interlaboratory quality control study in five laboratories on the electron capture gas chromatographic determination of ten chlorinated insecticides in standards and spiked and unspiked seawater samples (lindane, heptachlor, aldrin, δ -chlordane, α -chlordane, dieldrin, endrin, *p, p'*-DDT, methoxychlor, and mirex). The methods of analyses used by these workers were not discussed, although it is mentioned that the methods were quite similar to those described in the water quality Branch Analytical Methods Manual [339]. Both hexane and benzene were used for the initial extraction of the water samples.

Results obtained by the five laboratories were reasonably consistent, and lindane recovery varied between $113 \pm 31\%$ and $83 \pm 25\%$. Heptachlor revealed poor recovery, which confirmed its degradation [339–344]. The degradation product [340–342] is known to be 1-hydroxychlordene.

9.18.2

High-Performance Liquid Chromatography

Samuelson [345] has reported an HPLC method for the determination of trichlorofos and dichlorvos in seawater. A methyl cyanide phosphate buffer was used and detection was achieved by ultraviolet measurements at 205 nm.

9.19

Polychlorobiphenyls

In actual practice, environmental samples which are contaminated with PCB are also highly likely to be contaminated with chlorinated insecticides. Many reports have appeared discussing co-interference effects of chlorinated insecticides in the determination of PCB and vice versa, and much of the more recent published work takes account of this fact by dealing with the analysis of both types of compounds. This work is discussed below.

9.19.1

Gas Spectrofluorometry

The fluorescence enhancement of 3, 4, 4'-trichlorobiphenyl [361] and 3, 3', 4, 4'-tetrachlorobiphenyl [362] in the presence of POLE has been used for their quantitation at levels as low as 4.9 and 1.4 ng/ml, respectively, in seawater.

9.19.2

Gas Chromatography

PCBs have gas chromatographic retention times similar to the organochlorine insecticides and therefore complicate the analysis when both are present in a sample. Several techniques have been described for the separation of PCB from organochlorine insecticides. A review of these methods has been presented by Zitko and Choi [346]. These techniques are time-consuming and, in general, semi-quantitative. In addition, differential adsorption or metabolism of the Aroclor isomers in marine biota prevent accurate analysis of the PCBs. The gas chromatographic determination of chlorinated insecticides together with PCBs is difficult. Chlorinated insecticides and PCBs are extracted together in routine residue analysis, and the gas chromatographic retention times of several PCB peaks are almost identical with those of a number of peaks of chlorinated insecticides, notably of the DDT group. The PCB interference may vary, because the PCB mixtures used have different chlorine contents, but it is common for PCBs to be very similar to many chlorinated insecticides and the complete separation of chlorinated insecticides from PCBs is not possible by gas chromatography alone [347–351].

Figure 9.3 illustrates the possibility of the interference of DDT type compounds in the presence of PCBs. In an early paper on the determination of PCBs in water samples which also contain chlorinated insecticides, Ashling and Jensen [352] pass the sample through a filter containing a mixture of Carbowax 4000 monostearate on Chromosorb W. The adsorbed insecticides are eluted with light petroleum and then determined by gas chromatography on a glass column (160 × 0.2 cm) containing either 4% SF-96 or 8% QF-1 on Chromosorb W pretreated with hexamethyldisilazane, with nitrogen as carrier gas (30 ml/min) and a column temperature of 190 °C. When an electron capture detector is used the sensitivity is 10 ng lindane per cubic meter with a sample size of 300 litres. The recoveries of added insecticides range from 50 to 100%; for DDT the recovery is 80% and for PCB, 93–100%.

Musty and Nickless [353] used Amberlite XAD-4 for the extraction and recovery of chlorinated insecticides and PCBs from water. In this method a glass column (20 × 1 cm) was packed with 2 g XAD-4 (60–85 mesh), and 1 litre of tap water (containing 1 part per 10⁹ of insecticides) was passed through the column at 8 ml/min. The column was dried by drawing a stream of air through, then the insecticides were eluted with 100 ml ethyl ether-hexane (1:9). The eluate

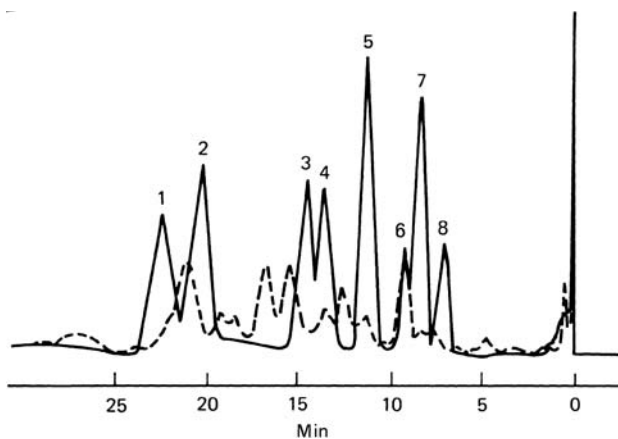

Figure 9.3. Interference of DDT-type compounds in the presence of PCBs. Gas chromatography: 5% QF-1 on Gas Chrom Q, 100–120 mesh. Solid line: 1 *p, o'*-DDT; 2 *p, p'*-DDD; 3 *o, p'*-DDT; 4 *o, p'*-DDD; 5 *p, p'*-DDE; 6 *p, p'*-DDMU; 7 *o, p'*-DDE; 8 *o, p'*-DDMU. Broken line = PCB Chiophen A 50. Source: [346]

was concentrated to 5 ml and was subjected to gas chromatography on a glass column (1.7 m × 4 mm) packed with 1.5% OV-17 and 1.95% QG-1 on Gas-Chrom Q (100–120 mesh). The column was operated at 200 °C, with argon (10 ml/min) as carrier gas and a ^{63}Ni electron capture detector (pulse mode). Recoveries of BHC isomers were 106–114%, of aldrin 61%, and of DDT isomers and polychlorinated biphenyls 76%.

Girenko et al. [354] noted that PCBs interfered with the electron capture gas chromatographic identification and determination of chlorinated insecticides in water and fish. Prior to gas chromatography, water samples and biological material were extracted with *n*-hexane. A mixture of organochlorine insecticides was completely separated. Girenko et al. [354] noted that it was difficult to analyse samples of seawater because they are severely polluted by various co-extractive substances, chiefly chlorinated biphenyls. To determine organochlorine insecticide residues by gas chromatography with an electron capture detector, the chlorinated biphenyls were eluted from the column together with the insecticides. They produce inseparable peaks with equal retention time, thus interfering with the identification and quantitative determination of the organochlorine insecticides. The presence of chlorinated biphenyls is indicated by additional peaks on the chromatographs of the water samples and aquatic organic organisms. Some of the peaks coincide with the peaks of the *o, p'* and *p, p'* isomers DDE, DDD, and DDT, and some of constituents are eluted after *p, p'*-DDT.

Elder [355] determined PCBs in Mediterranean coastal waters by adsorption onto XAD-2 resin followed by electron capture gas chromatography. The overall average PCB concentration was 13 ng/l.

Amberlite XAD-2 resin is a suitable adsorbent for polychlorinated biphenyl and chlorinated insecticides (DDT and metabolites, dieldrin) in seawater. These compounds can be suitably eluted from the resin prior to gas chromatography [356, 358].

Picer and Picer [357] evaluated the application of XAD-2, XAD-4, and Tenax macroporous resins for concentrations of chlorinated insecticides and polychlorinated biphenyls in seawater prior to analysis by electron capture gas chromatography. The solvents that were used eluted not only the chlorinated hydrocarbons of interest but also other electron capture sensitive materials, so that eluates had to be purified. The eluates from the Tenax column were combined and the non-polar phase was separated from the polar phase in a glass separating funnel. Then the polar phase was extracted twice with *n*-pentane. The *n*-pentane extract was dried over anhydrous sodium sulfate, concentrated to 1 ml and cleaned on an alumina column using a modification of the method described by Holden and Marsden. The eluates were placed on a silica gel column for the separation of PCBs from DDT, its metabolites, and dieldrin using a procedure described by Snyder and Reinert [359] and Picer and Abel [360].

Picer and Picer [357] investigated the recovery from 10 litre samples of seawater of 0.1–1.0 µg/l chlorinated pesticides (DDT, DDE, TDE, and Dieldrin), and 1–2 µg/l PCB (Aroclor 1254). The recovery of Mirex during these steps varied between 80% and 90%. Losses of the investigated chlorinated hydrocarbons during these steps were 10–30% for about 10 ng pesticides.

Petrick et al. [363] used HPLC to remove aliphatic compounds from estuary waters prior to determining PCBs by gas chromatography.

Pedersen-Bjergaard et al. [364] compared three different methods (GC-ECD, GC-MS, GC-AED) for the determination of polychlorobiphenyls in highly contaminated marine sediments.

Leoni [366] observed that in the extraction preconcentration of organochlorine insecticides and PCB's from surface and coastal waters in the presence of other pollutants such as oil, surface active substances, etc., the results obtained with an absorption column of Tenax-Celite are equivalent to those obtained with the continuous liquid-liquid extraction technique. For non-saline waters that contain solids in suspension that absorb pesticides, it may be necessary to filter the water before extraction with Tenax and then to extract the suspended solids separately. Analyses of river and estuarine sea waters, filtered before extraction, showed the effectiveness of Tenax, and the extracts obtained for pesticide analysis prove to be much less contaminated by interfering substances than corresponding extracts obtained by the liquid-liquid technique. Leoni et al. [365] showed that for the extraction of organic micro pollutants such as pesticides and aromatic polycyclic hydrocarbons from waters, the recoveries of these substances from unpolluted waters (mineral and potable waters) when added at the level of 1 µg/l averaged 90%.

Water samples were passed through the peristaltic pump into the absorption column at a flow rate of about 3 litres per hour. When the absorption

on Tenax-Celite was completed the pesticides were eluted. For the analysis of naturally polluted water the solvent was evaporated, the residue dissolved in light petroleum, and the solution purified by partitioning with acetonitrile saturated with light petroleum [366, 367, 373]. The resulting solution was evaporated just to dryness, the residue dissolved in 1 ml of *n*-hexane, and insecticides and polychlorobiphenyls were separated into four fractions by deactivated silica gel micro column chromatography (silica gel type Grace 950, 60–200 mesh) [368]. The various eluates from the silica gel were then analysed by gas chromatography [369]. In order to evaluate the effectiveness of extraction from non-saline waters with the Tenax Celite column, the samples were also extracted simultaneously by the liquid–liquid technique.

In the adsorption with Tenax alone satisfactory results were obtained, while in the presence of mineral oil a considerable proportion of the organophosphorus pesticides (particularly Malathion and Parathion-methyl) was not adsorbed and was recovered in the filtered water. This drawback can be overcome by adding a layer of Celite 545 which, in order to prevent blocking of the column, is mixed with silanised glass wool plugs. A number of analyses of surface and estuarine sea waters were carried out by this modified Tenax column and simultaneously by the liquid–liquid extraction technique. To some of the samples taken, standard mixtures of pesticides were also added, each at the level of 1 µg/l (i.e., in concentration from 13 to 500 times higher than that usually found in the waters analysed). One recovery trial also specifically concerned polychlorobiphenyls. The results obtained in these tests show that the two extraction methods, when applied to surface waters that were not filtered before extraction, yielded very similar results for many insecticides, with the exception of compounds of the DDT series, for which discordant results were frequently obtained.

Leoni et al. [365, 370] conclude that the extraction of insecticide from waters by adsorption on Tenax yields results equivalent to those by the liquid–liquid procedure when applied to waters that do not contain solid matter in suspension. For waters that contain suspended solids that can adsorb some insecticides in considerable amounts, the results of the two methods are equivalent only if the water has previously been filtered. In these instances, therefore, the analysis will involve filtered water as well as the residue of filtration.

9.19.3

Column Chromatography

Millar et al. [371] carried out experiments to study a method for the recovery of 18 organochlorine pesticides and seven PCBs from water. Extractions with dichloromethane, and 15% dichloromethane in hexane, at pH 2, 7, and 10, and liquid–solid column chromatography using columns of Florasil or alumina, produced excellent results. An investigation was also made into the effects of

pH, temperature, and residual chlorine on the preservation of spiked samples, and recommendations were made for the most suitable storage conditions.

9.19.4

Miscellaneous

Kristiansen et al. [232] identified halogenated hydrocarbon byproducts in chlorinated seawater used for drinking water. Phenol, cresols, and catechols were present at low-ppb concentrations in San Diego Bay (CA, USA) [373].

Sullivan et al. [374] studied the loss of PCBs from seawater samples during storage.

Kelly et al. [372] has described a sampling apparatus constructed to collect 28 litre samples of seawater designed to minimise sample contamination derived from the ships environment. Its utility in the study of polychlorobiphenyls, pentachlorophenols, and organochlorine pesticides was investigated.

Petrick et al. [375] extracted up to 2000 dm³ of Atlantic Ocean waters using various solid resins. Down to 5 ng/dm were determined of chlorinated biphenyls, HCB, DDE, and polyaromatic hydrocarbons in samples taken at depths down to 4000 metres.

9.20

Organophosphorus Compounds

The soluble organic phosphorus compounds arising from natural sources have been examined by a number of techniques, including concentration by freeze-drying and separation by molecular size on Sephadex gels, by Minear [376] and Minear and Walanski [377]. The most familiar of these compounds, adenosine triphosphate, is normally considered to be found in the particulate fraction, and is measured by the well-known luciferin-luciferinase reaction [378]. An adaptation of the method for estuarine waters and sediments was published by Wildish [379] and improvements on the usual method, including improvements in sampling and sample handling, were discussed by Hofer-Siegrist [380].

9.20.1

Spectrophotometric Method

Weber [381] has described a kinetic method for studying the degradation of Parathion in sea water. Weber observed two pathways whereby Parathion is hydrolysed. The first reaction proceeds via dearylation with loss of *p*-nitrophenol:

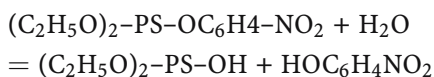

Additionally, they observed a second pathway, hydrolysis through dealkylation leading to a secondary ester of phosphoric acid which still contains the *p*-nitrophenyl moiety, i.e., de-ethyl Parathion (*O*-ethyl-*O*-*p*-nitrophenyl-monothio phosphoric acid):

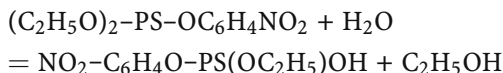

Aliquots of ethanolic solution of Parathion were separated into decomposed insecticides and decomposed insecticide products. Among the products free *p*-nitrophenol, chemically bound in acidic phosphorus compounds and in non-hydrolysed neutral phosphorus compounds, was detected in the same way after specification. Saponification after removal of ether without separation of neutral and acidic compounds yielded total *p*-nitrophenyl equivalents.

9.20.2

Gas Chromatography

Lores et al. [382] discussed the determination of the organophosphate insecticide fenthion in seawater. The method comprises a solvent extraction followed by silica gel clean-up procedure prior to determination by gas chromatography with thermionic detection. Detection levels of 0.01 $\mu\text{g/l}$ were achieved.

The insecticide fenitrothion (*O,O*-dimethyl-*O*-4-nitro-3-methylphenyl thiophosphate) can be measured in sea water and sediments by gas chromatography, using a flame photometric detector to determine P and S [387]. The degradation products of the organophosphorus insecticides can be concentrated from large water by collection on Amberlite XAD-4 resin for subsequent analysis [383].

9.20.3

Enzymatic Methods

The anticholinesterase nerve gases isopropyl methyl phosphonofluoridate (GB) and *O*-ethyl *S*-diisopropylaminoethylmethylphosphonothioate (VX) can be measured in seawater by an enzymic technique [384].

Cambella and Antia [385] determined phosphonates in seawater by fractionation of the total phosphorus. The seawater sample was divided into two aliquots. The first was analysed for total phosphorus by the nitrate oxidation method capable of breaking down phosphonates, phosphate esters, nucleotides, and polyphosphates. The second aliquot was added to a suspension of bacterial (*Escherichia coli*) alkaline phosphatase enzyme, incubated for 2 h at 37 °C and subjected to hot acid hydrolysis for 1 h. The resultant hot acid-enzyme sample was assayed for molybdate reactive phosphate which was estimated as the sum of enzyme hydrolysable phosphate and acid hydrolysable

phosphate. Phosphate concentrations were calculated as the difference between total phosphorus and molybdate-reactive phosphorus (enzyme hydrolysable phosphate plus acid hydrolysable phosphate) thus exploiting the inert nature of the strong carbon–phosphorus bond. This bond was resistant to phosphatase action and acid hydrolysis.

9.20.4

X-ray Fluorescence Spectrometry

Ahern et al. [386] has observed that organophosphorous compounds are co-precipitated with cobalt and pyrrolidine dithiocarbonate, and suggest that this might be a suitable means of preconcentrating the phosphorus fraction of harbour water prior to analysis by X-ray fluorescence spectrometry.

9.21

Azine Herbicides

9.21.1

Gas Chromatography

Wu et al. [388] carried out measurements of the enrichment of Atrazine on the micro surface water of an estuary. These authors used a micro surface water sampling technique with a 16 mesh stainless steel screen collecting bulk sampled from the top 100–150 μm of the surface. Atrazine concentration in the actual micro surface was estimated to vary in the range 150–8850 $\mu\text{g/l}$.

Abel et al. [389] determined simazine in estuary water by adsorption on a C_{18} SPE cartridge followed by determination by HR-GC using a nitrogen-phosphorus specific detector.

9.21.2

Gas Chromatography–Mass Spectrometry (GC–MS)

Durand and Barcelo [390] carried out a study of the interferences in the analysis of chlortriazines in seawater using GC–MS secondary ion monitor spectrometry and by GC using a nitrogen–phosphorus specific detector C_{39} .

Electrospray mass spectrometry has been used to characterise triazine, phenylurea, and other herbicides in estuarine water [391].

9.21.3

High-Performance Liquid Chromatography (HPLC)

A C_{18} disk has been used to remove chlorotriazine, atrazine, metabolites, organophosphorus compounds, phenylurea, and carbamate pesticides from seawater prior to analysis by HPLC [392].

A study has been carried out on the determination of triazine and carbamate pesticides and metabolites in seawater by HPLC with photodiode-array detection [393].

9.22

Diuron, Irgalol, Chlorothalonil

Ferrer and Barcelo [394] used solid-phase extraction coupled with LC-MS to determine diuron, irgalol, and chlorothalonil in seawater in amounts down to 1 ng/l.

9.23

Lipids

Marine lipids are important biological energy sources and have been used as tracers in food studies [395–398]. Some lipids, however, are pollutants [399, 400], and all lipids can potentially act as solvents, transporters, or sinks for pollutants [374, 399, 401, 402].

The rapidity with which the Iatroscan THIO MK II (Iatron Laboratories, Tokyo) TLCFID flame ionisation detector system provides synoptic lipid class data from small samples suggested that it would be useful for screening seawater samples prior to performing more detailed chromatographic analyses. The lipid class concentrations obtained by TLCFID provide reference values for the concentrations of the individual components obtained by other techniques. In particular, shipboard TLCFID analysis would help in deciding sampling strategies for more detailed investigations. In addition, the TLCFID technique alone could provide an overall picture of spatial or temporal variations in the distribution of a complete range of lipid classes.

Standards used for the construction of calibration curves had alkyl chain lengths in the range C₁₆ to C₁₉. Table 9.2 gives the principal compounds used as representatives of each class.

Lipids were separated on the thin-layer plate with solvents of increasing polarity.

This technique was used by Delmas et al. [404] to separate lipid extracts in seawater into various classes. Lipid classes that have been eluted away from the point of application may be burnt off the rod in a partial scan, allowing those lipids remaining near the origin to be developed into the place that has just been simultaneously scanned and reactivated. By analysis of complex mixtures of neutral lipids in this stepwise manner it is possible to be more selective about lipid class separations as well as to be more confident about assigning identities to peaks obtained from a seawater sample. In addition, this approach also reduces the possibility of peak contamination by impurities which would normally coelute with marine lipid classes (e.g., phthalate esters [403]).

Figure 9.4 shows the type of results attained by this procedure.

Table 9.2. Seawater lipid classes and standards used for their identification and calibration

Class	Abbreviation	Standards and suppliers
Aliphatic hydrocarbons	HC	Nonadecane (Polyscience)
Wax and sterol esters	WE	Hexadecyl palmitate (Analabs)
3-Ketone (internal stand)	KET	Hexadecan-3-one (K & K Labs)
Free fatty acid	FTA	Palmitic acid (Supelco)
Triglyceride	TG	Tripalmitin (Supelco)
Free alcohol	ALC	Hexadecan-1-ol (Polyscience)
Free sterol	ST	Cholesterol (Supelco)
Polar lipid	PL	Dihexadecanoyl lecithin (Supelco)

Source: Author's own files

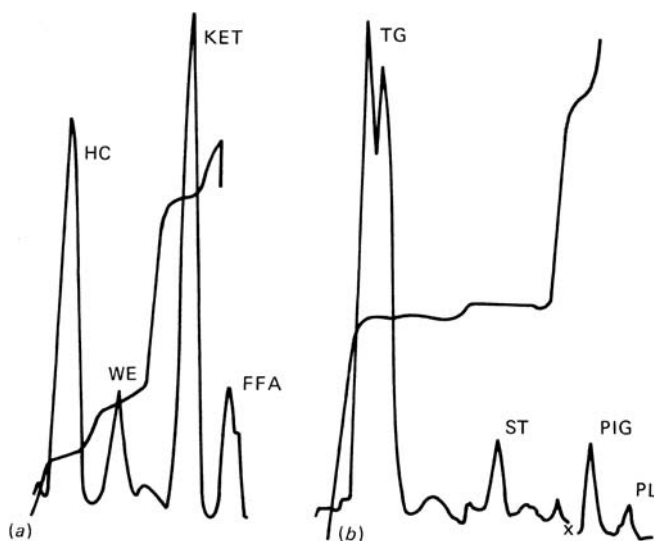
**Figure 9.4.** Shipboard analysis of particulate lipid classes on the same Chromarod. **a** Non-polar neutral lipids and internal standard, partial scan. **b** Remaining neutral lipids and polar lipids, full scan, increased attenuation at X. Source: [404]

9.24 Sterols

No class reaction has been proposed for the measurement of total sterols. Instead, various fractionation methods, usually derived from the biochemical literature, have been adapted to the concentrated materials collected from seawater. Certain of the more important sterols, particularly those used in the evaluation of water quality, have been determined by the use of a compound-specific reaction, after concentration from solution. Thus Wann et al. [405,

407] measured coprostanol, a faecal sterol in seawater, after collection and separation, by extraction using liquid-liquid partitioning or extraction on a column of Amberlite XAD-2 resin.

When solvent extraction was performed, the procedure used by Dutka et al. [406] was followed with a slight modification: 2 ml of concentrated hydrochloric acid and 5 ml of 20% (w/v) sodium chloride were added to each litre of water sample. The sample was extracted with vigorous mixing three times with 100 ml each of hexane for 30 min. The combined extract was washed with two 50 ml portions of acetonitrile (saturated with hexane) followed by two 50 ml portions of 70% ethanol. The hexane was then brought to dryness on a rotary evaporator under reduced pressure. The sample was re-dissolved in 100–200 μl of carbon disulfide, and 1–5 μl of the solution was used for gas chromatographic analysis.

^{14}C -labelled cholesterol was used to test the recovery of 5–100 μg of faecal sterols from seawater (labelled coprostanol not being available). The radioactivity of the samples and eluates was measured by a two-channel liquid scintillation counter. Percentage recovery was calculated on the basis of the amount of labeled material recovered in the acetone eluant. The results indicate that column extraction efficiency is not adversely affected by the salinity of the water samples, i.e., in the range 95–97%.

Most often the sterols have been collected by liquid-liquid extraction using petroleum ether and ethyl acetate [408], chloroform and methanol [409], *n*-hexane [410, 411] or chloroform [412, 413]. After concentration, gas chromatography was generally used for the final separation and determination, although thin-layer chromatography has also been employed. The extra sensitivity of the electron capture detector could be used by reacting the concentrated sterols with bromomethyldimethylchlorosilane (BMDS) before separation and measurement [414].

An analysis performed by gas chromatography can usually also be performed by coupled gas chromatography-mass spectrometry, often with some increase in sensitivity, and with considerably greater certainty in the identification of the compounds. This technique has been applied to seawater [415] and to marine sediments [416].

While most of the interest in sterols has been in the materials in solution, Kanazawa and Teshima [417] have investigated the compounds present in suspension. The suspended matter was fractionated by filtration through a graded series of filters, the sterols removed by extraction with an organic solvent, and the final separation and determination was made by flame ionisation gas chromatography.

Gas chromatography appears to give adequate separation and measurement of the various sterols to be found in the marine environment; where it is less than satisfactory is in the identification of the substances being measured. With compounds whose structures can be so similar, only gas chromatography-mass spectrometry can be expected to provide reasonable identifications.

9.25 Chelators

While a great many compounds that have been or might be found in the marine environments have been accused of chelation, this section deals only with the nonspecific measurements of chelation, with what has been called “chelation capacity”. In general, this capacity is measured by spiking the solution with a transition metal, preferably one that is easily measured, and then determining either how much is complexed or how much is left over. While the principle of all of the methods is the same, the details are different, and often quite ingenious.

The metals used are usually copper or cobalt. A good example of a relatively simple approach is the paper by Hanck and Dillard [418]. They add an excess of Co^{II} , which forms strong but labile complexes with the organic materials present. After complex formation, dilute hydrogen peroxide is added, to oxidise the complex to the Co^{III} form, which is much less labile. The excess hydrogen peroxide is then destroyed and the unreacted Co^{II} measured by differential pulse polarography.

Another relatively simple approach is that of Stolzberg and Rosin [419]. The sample is spiked with an excess of copper, then passed through a Chelex 100 column. The column retains the free copper ion, but passes the copper associated with strong ligands. The chelated copper eluted from the column is measured by plasma emission spectrometry.

A kind of “standard additions” approach can also be used for the measurement of apparent complexing capacity. In this technique, labile copper is measured by differential pulse anodic stripping voltammetry after each of a number of spikes of ionic copper have been added to the sample [420].

In terms of solution chemistry, “apparent” capacities derived from the extremely dilute and diverse natural samples, determined at natural pH values, are very crude. To get results that are more exact, or tell more about the possible nature of the complexing materials, it is necessary to concentrate, and sometimes to separate out, the organic chelators. This approach has been used by Buffle et al. [421]. Working with river water, they were able to concentrate and clean up their samples to the point where they were able to treat the chelating material almost as reagents, and to determine mean molecular weights for the ligands, stability constants for the complexes and the pH dependency of the stability of the complexes. This work would be considerably more difficult in seawater, but if the same organic materials were to be found in both fresh and seawater, it might be possible to determine the various values for fresh water and then to determine the effect of ionic strength on these quantities.

When the chelators are actually known, as in the case of industrial materials injected into the environment, it is possible to derive much more information from the analyses. Thus high pressure liquid chromatography has been used to separate the copper chelates of EDTA, NTA, EGTA, and CDTA with the final measurement of copper being made by atomic absorption [422, 423].

A spectrophotometric method based on the light absorption of the coloured Co^{III} complexes has been used to determine EDTA and NTA in fresh water [424]. In these few cases, actual well-defined compounds were present at concentrations high enough so that the individual compound could be isolated, identified, and measured. This is seldom the case for the chelators in seawater: we are usually measuring an attribute, not a compound, with little idea of the actual identity of the compounds.

9.26

Humic Materials and Plant Pigments

Humic materials cover three main classes of compounds which are discussed below under separate headings. They include:

1. Fluorescent yellow materials known collectively as "Gelbstoff" (yellow material)
2. Lignins and lignin sulfonates
3. Humic and fulvic acids

While in a strict sense only the last class of compounds should fall into the category of humic materials, there has been much dispute concerning the origin of the marine humic materials; both Gelbstoff and the lignins have been mentioned as probable starting compounds for the marine humic and fulvic acids.

Chlorophyll is also discussed in this section.

(a) Gelbstoff

Under this heading are discussed both the naturally occurring fluorescent material and the yellow substances which give coastal waters their generally greenish colour. It is usually considered that these two categories are the same, or at least overlap almost entirely.

An in situ technique for measuring fluorescence in the ocean has been developed by Egan [425]. His sensors, set to measure separately both chlorophyll and Gelbstoff fluorescence, can be lowered to 600 m and operate unattended.

Gel filtration with Sephadex was used by Ghassemi and Christman [426] to make separations by molecular size on water samples concentrated by vacuum evaporation. Fluorescence was also used as one method for following the fractionation. Molecular size was also used by Gjessing [427] but with pressure dialysis as the method of separation. A similar method of concentration and separation was used by Brown [428] to follow the dispersion of these materials as fresh and salt water mixed in the Baltic Sea.

A method of concentration by adsorption on aluminium oxide has been proposed. It achieved almost complete adsorption.

The argument has been made by several investigators (see the review by Wangersky [429]) that the humic materials in seawater are not derived from terrestrial sources, but result from light-induced condensation reactions of phenolic material and proteins released by fixed algae in the coastal regions. These materials can be collected on nylon-packed chromatographic columns [430]. Methods of collection and fractionation, as well as studies on the chemical and physical properties of these compounds, were discussed by these authors [431]. These compounds seem to be relatively easy to collect, to fractionate, and to follow through the various chemical procedures.

(b) Lignins

Lignins and lignin sulfonates are considered to be important tracers of man's activities. The major source of these compounds is the pulp and paper industry; lignin is not a marine product, and any large accumulation of these compounds suggests a local dominance of terrestrial materials.

Pocklington and Hardstaff [432] react sediment samples with 1,3,5-trihydroxybenzene in alcoholic hydrochloric acid to produce a colour in the particulate lignins, facilitating their identification under the microscope. Samples high in lignins can then be subjected to the normal methods of analysis. This is an excellent screening technique (semi-quantitative).

A concentration step is often used in order to bring the sample within the concentration range of the method. Thus Stoeber and Eberle [433] extracted the lignosulfonic acids with trioctylamine in chloroform before final determination, and Revina and Kriul'kov [434] employed spectrophotometric methods. Extraction is also used to remove interferences in spectrophotometric methods [435].

Direct spectrophotometric methods have been proposed for both particulate and dissolved lignosulfonic materials. Kloster [436] used the Folin Ciocalteu method, which actually measures hydroxylated aromatic compounds. A general review of spectrophotometric methods was published by Bilikova [437].

Certain derivatives of the lignin sulfonic acids can be determined directly in water. The nitroso derivatives, which are easily formed in solution, can be determined by differential pulse polarography [438]. Vanillin can be formed by alkaline hydrolysis [439] or alkaline nitrobenzene oxidation [440], extracted into an organic solvent and determined by gas chromatography.

As a general rule, fluorometric methods are considerably more sensitive than spectrophotometric methods, although standardisation is more difficult. Direct fluorometric procedures for lignin and lignin sulfonates have been described [441–443].

(c) Humic and Fulvic Acids

The designation of certain classes of organic materials as humic and fulvic acids unfortunately implies a certainty and regularity of structure which

is far from true. These terms, derived from soil science, indicate only the products resulting from a particular sequence of fractionation; humic acids are those compounds extracted from soils by alkaline solutions and precipitated upon acidification, while fulvic acids are those extracted by alkaline solutions but left in solution on subsequent acidification [444]. While these terms were originally specific to soil science, and to materials isolated from soils, the usage was gradually extended to marine sediments and then by further extension to materials isolated from solution by similar techniques.

Evidence is accumulating which shows that materials isolated from the marine environment are quite unlike those isolated from soils, at least in $^{13}\text{C}/^{12}\text{C}$ ratios and probably in structure.

The methods for isolating humic and fulvic acids from marine samples can be found in King [445], Rashid and King [446], and Pierce and Felbeck [447]. These techniques, which derive from soil chemistry, may be used when the sample is a marine sediment. However, when it is the material in solution that is being separated, the application of the methods is not so straightforward. Several workers have used macroreticular resins, usually XAD-2, to collect high molecular weight materials from seawater [448–450]. It has been demonstrated that this resin will, in fact, collect the humic and fulvic acids separated from soils by the usual methods [450]. It has therefore been assumed that the materials collected by this resin from seawater are the humic and fulvic acids, although the characteristics of the fractions so collected are different from those collected from terrestrial soils and marine sediments [448, 451].

Applications of NMR, ESR, thermal analysis, spectrophotometry, gas chromatography, and GC-MS to humic and fulvic acid analysis have been reviewed by Schnitzer [452].

Salfeld [453] has shown that qualitative information on the nature of the compounds present can be found by means of derivative spectrophotometry. The concentration of fulvic acids in natural waters can be calculated from the ultraviolet absorption at 400 and 340 nm, after removal of the humic acids [454]. If a somewhat greater degree of uncertainty as to the actual composition of the materials is acceptable, sample preparation can almost be eliminated, and the sensitivity of the method increased, by using fluorescence rather than absorption as the measure of the humic materials present [441, 443]. However, it must always be remembered that in this method of analysis we are equating humic materials with all of the soluble compounds fluorescing in the proper region; the correspondence is not necessarily exact. In addition, the fluorescence of humic and fulvic acids is rapidly decreased as sea surface sunlight intensities. The fluorescence may therefore behave as a highly non-conservative indicator for these materials in surface waters.

Many of the methods used for lignins can also be applied to humic acids. Thus the use of pulse polarography after the formation of nitroso derivatives is possible with humic acids as well as lignins [433, 443]. If the fulvic acids are

removed on activated charcoal, then eluted with acid, they can be determined by ac polarography [455].

Separation of the humic acids into molecular size classifications by gel permeation chromatography has been used largely to determine the distribution of sizes within this group of compounds [456]. The information coming from such fractionation cannot be taken at face value, however, since the elution of the humic materials is strongly influenced by the functional groups present, the pH, and the ionic strength. Such fractionation can profitably be used as a first step in the GC-MS determination of the compounds present. For those compounds too large or too complex to be determined directly by gas chromatography-mass spectrometry, oxidation [457] or hydrolysis [458] can be useful preliminary treatments.

For a rough estimation of the relative amounts of humic and fulvic acids, the fluorometric method has much to recommend it, not the least being its simplicity. Also, the ability of the method to measure short-range variability might be quite valuable. It is not possible to be certain of the value of any more detailed or more exact information until a great deal more is known about the nature of the compounds in each of these fractions.

(d) Chlorophyll Spectrometry

While the spectrophotometric determination of plant pigments, particularly the chlorophylls, has become a routine procedure [459,460], refinements aiming at either greater accuracy (usually by the separation and determination of the separate pigments) or greater sensitivity continue to appear in the literature. A review of the various methods, both for total pigments and for each separate pigment, was written by Rai [461]. A method using separation of pigments by TLC and determination by densitometry was described by Messiha-Hanna [462], while Quirry et al. [463] discussed a laser absorption spectrometry method with a sensitivity a hundred times that of the usual spectrophotometric method.

Bjarnborg [464] has studied shipboard methods of continuous recording of *in vivo* chlorophyll fluorescence and extraction-based chlorophyll determinations in Swedish archipelago waters.

Boto and Bunt [465] used thin-layer chromatography for the preliminary separation of chlorophylls and phaeophytins from seawater, and combined this with selective excitation fluorometry for the determination of the separated chlorophylls *a*, *b*, and *c*, and their corresponding phaeophytin components. An advantage of the latter technique is that appropriate selection of excitation and emission wavelengths reduces the overlap among the emission spectra of the various pigments to a greater extent than is possible with broadband excitation and the use of relatively broadband filters for emission.

The fluorescence studies were performed on 90% acetone solutions with an Aminco-Bowman spectrofluorometer (Model J4-8203G).

Figure 9.5 shows an excitation and emission spectrum for chlorophylls *a*, *b*, and *c*, and their respective phaeophytins. The excitation spectra were obtained by holding the emission wavelength at the emission maximum and slowly scanning the excitation wavelength over the required range. The emission spectra shown have not been corrected for changes in photomultiplier response with wavelength. These spectra show that with suitable choice of excitation wavelengths, good selectivity can be achieved. Assuming that a given mixture contains all three chlorophylls and their phaeophytins, a set of simultaneous equations can be derived for the emission responses at the usual emission maxima of each pigment when the mixture is excited at various chosen wavelengths. After acidification of the mixture to phaeophytins alone, further information can be obtained as indicated below (solutions of the phaeophytins were prepared from the corresponding chlorophylls by adding 2 drops of 0.1 M hydrochloric acid per 100 ml solution).

Although the equations are complex, in most cases the minor terms are such that many can be neglected. Further simplification is often possible when one considers that, in most offshore seawater samples, the only primary pigments found are chlorophylls *a* and *c*, along with phaeophytin *a*. Chlorophyll *b* and phaeophytins *b* and *c* are either absent or present in minor amounts. Phaeophorbides are also commonly found. However, these would probably have very similar fluorometric properties to the phaeophytins, and hence could not be separately determined by any fluorometric method.

Taking into account the most likely pigment compositions of the phytoplankton in most seawater samples, a simplified set of equations was obtained. As the quantum efficiency of chlorophyll *c* appears to be very high, its emission spectrum is very little affected by interference from the emissions of other pigments.

Therefore, its concentration can be quite accurately calculated and this value then used to give accurate estimates of the others.

Murray et al. [466] carried out an intercomparison of the determination of chlorophyll in marine waters by methods based on HPLC, spectrophotometry, and fluorometry. Good agreement was obtained between these methods for chlorophyll *a* and chlorophyll *b*.

High-Performance Liquid Chromatography (HPLC)

Abayashi and Riley [467] used HPLC to determine chlorophylls, and their degradation products, and carotenoids in phytoplankton and marine particulate matter.

Pigment extraction is carried out with acetone and methanol. After evaporation of the combined extracts under reduced pressure, the pigments are separated on a Partisil-10 stationary phase with a mobile phase consisting of light petroleum (bp 60–80 °C), acetone, dimethyl sulfoxide and diethylamide (75:23.25:1.5:0.25 by volume). When chlorophyll *c* is present, a further develop-

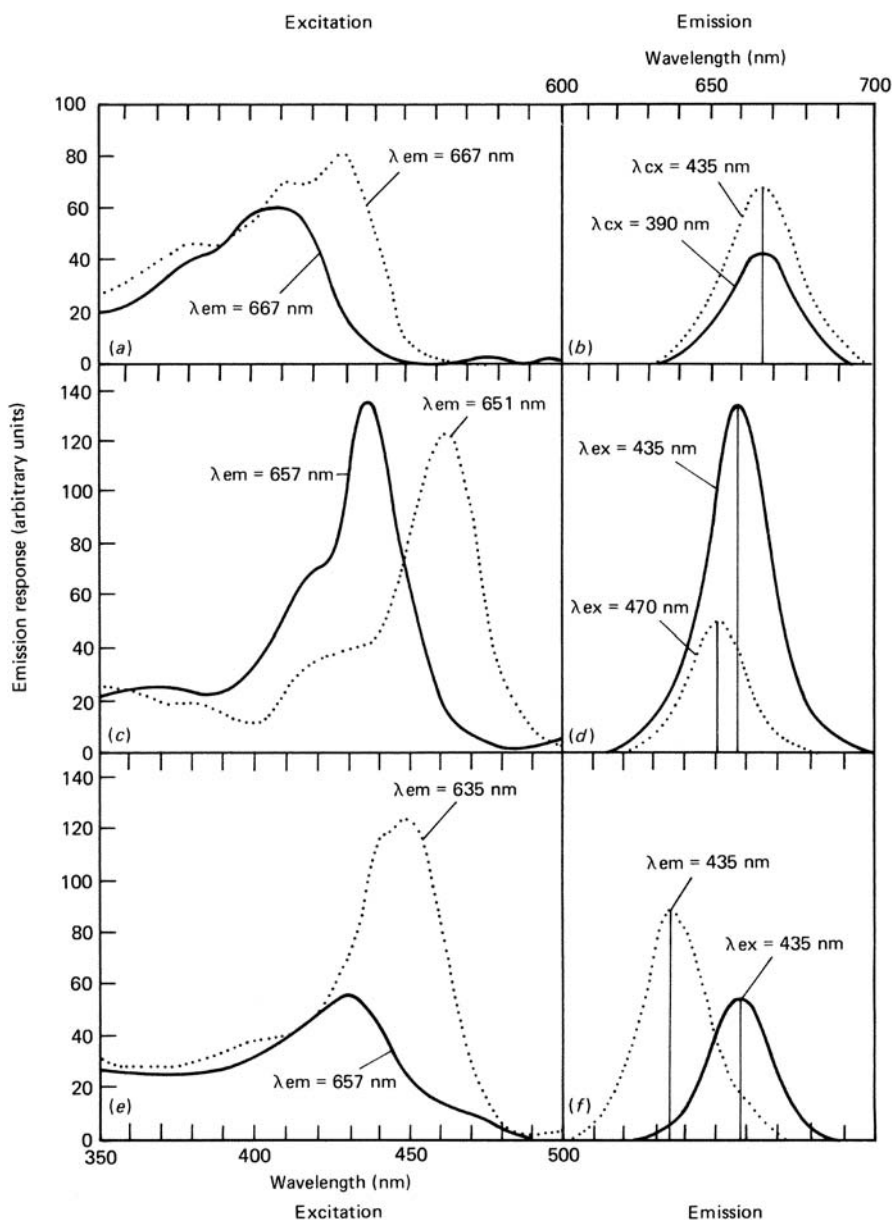

Figure 9.5. Excitation and emission spectra. (a and b) Chlorophyll *a* (---) and phaeophytin *a* (—); concentration of both 0.134 µg/ml. (c and d) Chlorophyll *b* (---) and phaeophytin *b* (—); concentration of both 0.172 µg/ml. (e and f) Chlorophyll *c* (---) and phaeophytin *c* (—); concentration of both 0.042 µg/ml. Note that the phaeophytin *c* curves are shown on a tenfold higher sensitivity scale to the others. All solutions are in 90% acetone. Source: [465]

ment is performed with a similar, but more polar, solvent mixture. Detection is carried out spectrophotometrically at 440 nm. The method has a sensitivity for the chlorophylls of approximately 80 ng, and for the carotene of approximately 5 ng. The coefficient of variation of the chromatographic stage of the procedure lies in the range 0.6–1.8%.

Abayashi and Riley [467] compared results obtained by the HPLC method with those obtained by a reflectometric thin-layer chromatographic method and the SCOR/UNESCO polychromatic procedure. The results obtained from the latter were evaluated by the SCOR/UNESCO equations. The carotenoids were determined collectively from the absorption of the 90% acetone extract at 480 nm by means of the equations of Strickland and Parsons [459]. The results of these comparative studies show that there is satisfactory agreement for all pigments between the two chromatographic methods. However, although the results for chlorophyll *a* by the polychromatic method were in reasonable accord with those derived chromatographically, many of those for the other chlorophylls were highly discrepant. Obviously, the polychromatic method, in particular, is unsatisfactory with respect to the interference of chlorophyll degradation products, as these are nearly always present in environmental samples.

Thin Layer Chromatography

Garside and Riley [468] have used thin-layer chromatography to achieve a preliminary separation of chlorophylls on solvent extracts of water and algae prior to a final determination by spectrophotometry or fluorometry. Garside and Riley [468] filtered sea water samples (0.5–5 litres) through Whatman GF/C glass fiber coated with a layer, 1–2 mm thick, of light magnesium carbonate. This retains the smallest particles of organic matter and it is easy to extract the pigment from it. The filter is extracted with acetone (3–5 ml) and then with methanol (10 ml) using ultrasonic vibration. The solution is passed through anhydrous sodium sulfate to remove water and then evaporated in vacuum at less than 50 °C. The residue is dissolved in ethyl ether-dimethylamine (99:1, 1–2 ml), and this is applied as a spot to a plate coated with silica gel PF₂₅₄. The chromatogram is developed with light petroleum (bp 60–80 °C, ethyl acetate-dimethylamine (55:32:13)) until the centre of the chlorophyll *a* spot has traveled about 10 cm from the origin. The solvent is allowed to evaporate and the plate scanned by reflection of the light passing through an Ilford 601 filter (603 nm). The integration reading for each peak is measured and the *R_f* values noted relative to chlorophyll *a*. Xanthophylls are identified by scraping off the spots and measuring the absorption spectrum of an extract of the scrapings. Chlorophyll *c* remains at the origin and can be developed in light before chlorophylls *a*, *b*, and *c*, carotene, xanthophylls, and certain degradation products can be determined. The analysis takes 1 h, the sensitivity for chlorophyll *a* is about 0.12 µg, and the precision for most pigments is ±5% or better at the 0.5 µg level.

Karabashev [469] devised a method to estimate the influence of dissolved oxygen on remote sensing measurements of chlorophyll *a* in seawater. The relationship between fluorescence and absorption was studied in this investigation.

9.27

Vitamins

Only one analytical method has been widely applied to the measurement of vitamins in seawater. The method, bioassay, is not really within the realm of the analytical chemist, since it requires the maintenance of cultures of test organisms. The tests also usually require a minimum of four days before results are available.

The older methods for vitamin B₁₂ used the optical density of the culture medium as a measure of growth rate of the assay organism [470, 471]. The sensitivity of the method could be increased somewhat by the following ¹⁴C uptake as a measure of growth [472, 473]. These methods are sensitive to 0.1 ng, well below the amounts of the vitamin which could be measured by any available chemical technique.

Thiamine has also been measured by bioassay, a marine yeast being used as the assay organism [474, 475]. Marine bacteria [476, 477], marine yeasts [475], and dinoflagellates [478] have been used for the assay of biotin.

There are many uncertainties in the use of bioassay methods, not the least of these being the genetic stability of the assay organisms. Stock cultures cannot be treated like chemical reagents, to be put back on the shelf and forgotten between analytical runs. This is an area of analysis best left to the microbiologists; if the information is absolutely necessary, the maintenance of cultures and the actual assay should not be left solely in the hands analytical chemists.

9.28

Cobalamin

Sharama et al. [479] compared results obtained in the determination of cobalamins in ocean waters by radioisotope dilution and bioassay techniques. These workers showed that the isotopic methods measured both biologically active and inactive cobalamins indiscriminately when porcine factor was used as the B₁₂-specific binder.

9.29

Pectenotoxins

Suzuki et al. [480] developed a solid-phase extraction LC-MS method for determining pectenotoxin-2 and pectenotoxin-6 in seawater. These are toxins produced from toxic phytoplankton.

Table 9.3. Preconcentration of organics in seawater

Class of organic	Preconcentration method	Analytical finish	LD	Reference
Hydrocarbon	Extraction with organic solvents CH ₂ Cl ₂ CHCl ₃ CCl ₄ Cl ₃ FC C ₆ H ₆ C ₅ H ₁₂ Petroleum ether MeOH-C ₆ H ₆ EtOOCCH ₃ -Petroleum ether		μg/l	[482–488] [489–492] [493–500] [501–503] [84] [504, 505] [506] [507] [508]
Hydrocarbon	Extraction with Cl ₃ CF ₃ , then adsorption on SiO ₂	Thermistor	5	[26]
Hydrocarbon	Pentane, hexane, CH ₂ Cl ₂		1–2 μg absolute	
Alcohols, ketones, aldehydes	Gas stripping, then adsorption on SiO ₂	GC-MS	1 μg/l	[509]
Amino acids	Adsorption on zirconium phosphate	–	–	[510]
Amino acids	Adsorption on ferric oxide	Ion exchange chromatography (IEC)	3 μg/l	[511, 512]
Amino acids	Solvent extraction of 2,4-dinitro phenol	AAS and TLC	–	[267]
Amino acids	Evaporation to dryness and ethanol extraction	Paper chromatography	FAA 16.3 μg/l CAA 6 μg/l	[166] [514]
Amino acids	Ligand exchange on Cu-Chelex	IEC	FAA 21 μg/l CAA 185 μg/l	[268, 515, 164, 270] [516]
Amino acids	Evaporated to dryness, desalted on Cu-Chelex	GC	CAA 129 μg/l	[516]
Amino acids	Extraction of dried salts with acid, 80% ethanol desalted	Paper chromatography	FAA 2.3 μg/l CAA 5.8 μg/l	[248]
Amino acids	Extraction of dried salts with acid	IEC	FAA 6 μg/l	[273]
Amino acids	Extraction of dried salts with acid	TLC	FAA 4.5 μg/l CAA 2.1 μg/l	[246]

Table 9.3. (continued)

Class of organic	Preconcentration method	Analytical finish	LD	Reference
Amino acids	Freeze drying, ether-ethanol extraction	GC	FAA 6 µg/l	[253]
Amino acids	Extraction with ethyl acetate, Cu-Chelex method	IEC	FAA 1.8 µg/l	[272, 517]
Amino acids	Desalt with Dowex 50WX8 at pH 3 - 4 lyophilisation	IEC	FAA 4.5 µg/l CAA 3.5 µg/l	[275, 518]
Amino acids	Ligand exchange on Cu-Chelex	IEC	FAA 1 µg/l CAA 10 µg/l	[249, 519]
Amino acids	Semiautomated Cu-Chelex method	IEC	FAA 0.5 µg/l 10 µg/l	[520, 521]
Humic acids	Adsorption on macroretic- ular resin XAD-2	-	-	[448-450]
Organochlorine and organo- phosphorus insecticides	Reverse osmosis			[270, 523]
Ethers, glycols, amines, nitriles, hydrocarbons, chlorinated hydrocarbons	Reverse osmosis			[522, 523]
Chlorinated insecticides	Adsorption on ion exchange resins, Amberlite XAD-21			[524]
Chlorinated insecticides	Adsorption on silicic acid Celite, desorption with petroleum ether			[525]
Chlorinated insecticides and polychlorobi- phenols	Adsorption on Tenax-Celite	GC	1 µg/l	[370, 526]
Organophospho- rus insecticides	Adsorption on Sephadex gel			[376, 377]
Miscellaneous (phenols, car- boxylic acids, sur- factants, carbo- hydrates, amino acids, proteins, insecticides, humic acids)	Adsorption on macroretic- ular resins, XAD1		2 - 5 µg absolute	[527, 528]

Table 9.3. (continued)

Class of organic	Preconcentration method	Analytical finish	LD	Reference
Miscellaneous	Adsorption on Sep-Pak C ₁₈ cartridges	-	-	[529]
Polyaromatic hydrocarbons, phenols	Extraction with methylene dichloride	GC-MS, HPLC	-	[530]
Aliphatic hydrocarbons	Adsorption on Tenax GC or a Chromasorb	GC	µg/l	[13, 15, 23]
Aliphatic hydrocarbons	Head space analysis	GC-MS		[531-534]
Organotin compounds	Adsorption on cation exchange resin	Polarography		[535]
Organotin compounds	Adsorption on XAD-2 resin, desorbed with hexane-methanol	-	-	[536]
Organomercury compounds	Extraction with dithizone solution	Gold trap cold vapour AAS	-	[537]

Source: Author's own files

9.30 Flavins

A method has been reported [481] for the determination of flavins in seawater. The method is based on solid-phase extraction. With ion-pair HPLC using fluorescence detection, concentrations in the picomolar range can be measured.

9.31 Microcystine

Metcalf et al. [543] used enzyme linked immunoassay (ELISA) to measure microcystine in marine water.

9.32 Preconcentration of Organics

Applications of preconcentration to µg/l levels are reviewed in Table 9.3.

References

1. Blumer M, Blokker PC, Cowell EB, Duckworth EF (1972) In: Goldberg ED (ed) A guide to marine pollution. Gordon and Breach Science Publishers, New York, pp 19-40
2. Farrington JW (1973) Analytical techniques for the determination of petroleum contamination in marine organisms. AD Report No.766792/6 US National Technical Information Service, Springfield, VA

3. Andelman JB, Snodgrass JE (1974) *Crit Rev Env Contr* 4:69
4. Institute of Petroleum (1974) Marine pollution by oil: characterization of pollutants, sampling, analysis, and interpretation. Applied Science Publications
5. McGlynn JA (1974) A review of techniques for the characterization and identification of oil spillages. In: Examination of waters, evaluation of methods for selected characteristics. Resource council technical paper no. 8, pp 85–89
6. Whitham BT, Duckworth DF, Harvey AAB, Jeffrey PO, Perry SG (1974) Characterization of pollutants, sampling, analysis, and interpretation. In: Whitham BT (ed) *Marine pollution by oil*. Applied Science Publishers, Essex
7. Erskine RL, Whitehead EV (1975) *Iranian Journal of Science and Technology* 3:221
8. IOC (1975) Report of the ICG for GIPME Task Team for the Evaluation of Recommendation No. IV of the Joint IOC/WMO Task Team II on the Marine Pollution Monitoring Project UNESCO Paris
9. Moulder DS, Varley A (1975) A bibliography on marine and estuarine oil pollution, supplement 1. Marine Biology Association
10. National Academy of Sciences, USA (1975) *Petroleum in the marine environment. A workshop on inputs, fates and the effects of petroleum in the marine environment*. Airlie, 1973
11. Fam S, Stenstrau MK, Silverman G (1987) *J Environ Eng* 113:1032
12. Wade TL, Quinn TG (1975) *Mar Pollut Bull* 6:54
13. May WE, Chester SN, Cram SP (1975) *J Chromatogr Sci* 13:535
14. Drodz J, Vadokova Z, Novak J (1986) *J Chromatogr* 354:47
15. Swinnerton JW, Linnenbom VJ (1967) *Science* 156:1119
16. Desbaumes E, Imhoff C (1972) *Water Res* 6:885
17. Polak J, Lu B (1974) *Anal Chim Acta* 63:231
18. Schönmann M, Kern H (1981) *Varian Instrument News* 15:6
19. Brooks JM, Sackett WM (1973) *J Geophys Res* 78:5248
20. Atkinson LP, Richard FA (1967) *Deep-Sea Res* 14:673
21. Perras JC (1973) Portable gas chromatographic technique to measure dissolved hydrocarbons in seawater. US NTIS AD report no 786583/5GA
22. Swinnerton JW, Linnenbom VJ (1967) *Science* 156:1120
23. Bellar TA, Lichtenberg JJ (1975) The determination of volatile organic compounds at the $\mu\text{g/l}$ level in water by gas chromatography. US National Technical Information Service report no. 237973/3GA
24. Wasik SB (1974) *J Chromatogr Sci* 12:845
25. Ahmadyan M, Brown CV (1976) *Anal Chem* 48:1257
26. Zsolnay A, Kiel MJ (1974) *J Chromatogr A* 90:79
27. Booksh KS, Muroski AR, Myrick ML (1996) *Anal Chem* 68:3539
28. Krstulovic AM, Rosie DM, Brown PR (1976) *Anal Chem* 48:1383
29. Hiltabrand RT (1978) *Mar Pollut Bull* 9:19
30. Payne JR (1976) *Science* 191:945
31. Isaaq HJ, Andrews AW, Janini GN, Barr EW (1979) *J Chromatogr* 2:319
32. Zitko V, Carson WV (1970) Tech Report Fish Res Bd Can No. 217
33. Michalik PA, Gordon DC (1971) Tech Report Fish Res Bd Can No. 284
34. Levy EM (1971) *Water Res* 5:723
35. Levy EM (1972) *Water Air Soil Poll* 1:144
36. Levy EM, Walton A (1973) *Journal of the Fisheries Research Board Canada* 30:261
37. Van Duuren BL (1960) *Anal Chem* 32:1436
38. Keizer PD, Gordon DC Jr (1973) *Journal of the Fisheries Research Board of Canada*, 30:1039

39. Cretney WJ, Wong CS (1974) Special publication no. 409. US National Bureau of Standards, p 175
40. Hellman H, Sehle H (1973) *Fresen Z Anal Chem* **265**:245
41. Hellman H (1975) *Fresen Z Anal Chem* **275**:109
42. Schwarz EP, Wasik SP (1976) *Anal Chem* **48**:524
43. Freearge M, Hatchard CG, Parker GA (1971) *Laboratory Practice* **20**:35
44. Thruston AD, Knight HW (1971) *Environ Sci Technol* **5**:64
45. Lloyd JBF (1971) *J Forensic Sci Soc* **11**:83
46. Lloyd JBF (1971) *J Forensic Sci Soc* **11**:153
47. Lloyd JBF (1971) *J Forensic Sci Soc* **11**:235
48. Parker CA, Barnes WJ (1960) *Analyst* **85**:3
49. Maher WA (1983) *Bull Environ Contam Tox* **30**:413
50. Red'Kin YR, Voitenko AM, Teplyakov PA (1973) *Okeanologiya* **13**:908
51. Liu J, Xie Z, Wang X, Wang R (1993) *Fenxie Shiyanshi* **12**:28
52. Kawahara FK (1969) *Environ Sci Technol* **3**:150
53. Kawahara FK, Ballinger DG (1970) *Ind Eng Chem Prod Res Dev* **9**:553
54. Kawahara FK, Johnson (1968) *Proceedings of the 11th Conference Great Lakes Research* p 550
55. Mattson JS, Mark HB (1970) *Anal Chem* **42**:234
56. Mattson JS, Mark HB (1969) *Environ Sci Technol* **3**:161
57. Kawahara FK (1972) *J Chromatogr Sci* **10**:629
58. Mark HB Jr, Yu T-C, Mattson JS, Kolpac R (1972) *Environ Sci Technol* **6**:833
59. Baier RE (1972) *J Geophys Res* **77**:5062
60. Pierre LJ (1973) *Applied Optics* **12**:2035
61. Lynch PF, Brown CW (1973) *Environ Sci Technol* **1**:1123
62. Ahmadjian M, Baer CD, Lynch PF, Brown CW (1971) *Environ Sci Technol* **10**:777
63. Mattson JS, Mattson CS, Spencer MJ, Starks SA (1977) *Anal Chem* **49**:297
64. Kawahara FE (1969) *Laboratory guide for the identification of petroleum products*. Department of the Interior Federal Water Pollution Central Administration, Analytical Quality Central Laboratory, Cincinnati, OH, USA
65. Institute of Petroleum Standardization Committee (1970) *Journal of the Institute of Petroleum* **56**:107
66. Ramsdale SJ, Wilkinson RE (1968) *Journal of the Institute of Petroleum* **54**:326
67. Brunnock JV (1968) *Journal of the Institute of Petroleum* **54**:310
68. Duckworth DF (1971) *Aspects of petroleum pollutant analysis*. In: Hepple P (ed) *Water pollution in oil*. Institute of Petroleum, London, p 165
69. Blumer M (1970) *Mar Biol* **5**:196
70. Adams IM (1967) *Process Biochem* **2**:33
71. Erhardt M, Blumer M (1972) *Environ Pollut* **3**:179
72. Zafiron OC, Myers J, Freestone F (1973) *Mar Pollut Bull* **4**:87
73. McKay TR (1972) In: *Proceedings of the 9th International Symposium on GM Chromatography*, Montreux, Switzerland, October, pp 33–38
74. Adland ER, Creaser LF, Matthews PHD (1972) *Anal Chem* **46**:64
75. Adlard ER, Matthews PHD (1971) *Natural Physical Science* **233**:83
76. Boylan DB, Tripp BN (1971) *Nature* **230**:44
77. Bulton NJ, Morris BF, Sas J, Bermuda J (1973) *Biological Research, Special Publication No. 10*
78. Zafiron OC, Oliver C (1973) *Anal Chem* **45**:952
79. Hertz HS, May WE, Chester SN, Gump BH (1976) *Environ Sci Technol* **10**:900

80. Garra ME Jr, Muth J (1974) *Environ Sci Technol* **8**:249
81. Wasik SP, Brown RL (1973) Determination of hydrocarbon solubility in seawater and the analysis of hydrocarbons in water-extracts. In: Proceedings of the conference on prevention and control of oil spills. American Petroleum Institute, Washington, DC, pp 223–237
82. Rasmussen DV (1976) *Anal Chem* **48**:1562
83. Smith DH (1972) *Anal Chem* **44**:536
84. Walker JD, Colwell RP, Hamming MC, Ford HI (1975) *Bull Environ Contam Tox* **13**:245
85. Brown RA, Huffman (1976) *Science* **101**:847
86. Albaiges J, Albrecht P (1979) *Int J Environ Anal Chem* **6**:171
87. Erhardt M, Blumer M (1972) *Environmental Pollution* **3**:179
88. Done JM, Reid WK (1970) *Separ Sci* **5**:825
89. Witmer FE, Goilan A (1973) *Environ Sci Technol* **7**:945
90. Matsumoto G, Hanya T (1981) *Water Res* **15**:217
91. Schuldiner JA (1951) *Anal Chem* **23**:1676
92. Lieberman M (1973) Report no. EPA-RZ-73-102. US Environmental Protection Agency
93. Wilson CA, Ferreto EP, Coleman HJ (1975) American Chemical Society, Division of Chemistry Reports **20**:613
94. Harwood JE, Huysen DJ (1968) *Water Res* **2**:631
95. Treguer P, Le Corre P, Courtot P (1972) *J Mar Biol Assoc of the UK* **52**:1045
96. Antia NJ, McAllister CD, Parsons TR, Stephens K, Strickland JDH (1963) *Limnol Oceanogr* **8**:166
97. Shah NM, Fogg GE (1973) *J Mar Biol Assoc of the UK* **53**:321
98. Shah NM, Wright RT (1974) *Mar Biol* **24**:121
99. Stradomska AG, Goncharova IA (1967) *Gidrokhim Mater* **43**:57
100. Garrett WD, Timmons CO, Jarvis NL, Kagarise RE (1963) Constitution and surface chemical properties of sea slicks, part 1, Bay of Panama. Report no. 5925. US Naval Research Laboratory, Washington, DC
101. Slowey JF, Jeffrey LM, Hood DW (1962) *Geochim Cosmochim Acta* **26**:607
102. Williams PM (1965) *Journal of the Fisheries Research Board of Canada* **22**:1107
103. Jeffrey LM (1966) *J Am Oil Chem Soc* **43**:211
104. Ackman RG, Sipos JC, Tocher CS (1967) *Journal of the Fisheries Research Board of Canada* **24**:635
105. Mahadevan V, Stenroos L (1967) *Anal Chem* **39**:1652
106. Blumer M (1970) Dissolved organic compounds in seawater. Saturated and olefinic hydrocarbons and singly branched fatty acids. In: Hood DW (ed) *Organic matter in natural waters*. Publication no. 1. Institute of Marine Science, University of Alaska, pp 153–167
107. Stauffer TB, MacIntyre WG (1970) *Chesapeake Science* **11**:216
108. Quinn JG, Meyers PA (1971) *Limnol Oceanogr* **16**:129
109. Meyers PA (1976) *Limnol Oceanogr* **21**:315
110. Garrett WD (1967) *Deep-Sea Res* **14**:221
111. Barger WR, Garrett WD (1970) *J Geophys Res* **75**:4561
112. Duce RA, Quinn JG, Olney CE, Piotrowicz SR, Ray BJ, Wade TL (1972) *Science* **176**:161
113. Schultz DM, Quinn JG (1972) *Journal of Fisheries Research* **29**:1482
114. Marty JC, Saliot A (1974) *Journal Rech Atmosphere* **13**:563
115. Ackman RG (1972) *J Chromatogr Sci* **10**:560
116. Di Corcia A, Samperi F (1974) *Anal Chem* **46**:140
117. Bjork RG (1975) *Anal Biochem* **63**:80

118. White WR, Leenheer JA (1975) *J Chromatogr Sci* **13**:386
119. Sever J, Parker PL (1969) *Science* **164**:1052
120. Schultz DM, Quinn JG (1974) *Mar Biol* **27**:143
121. White RH, Miller SL (1976) *Science* **193**:885
122. Mueller HF, Larson TE, Ferretti M (1960) *Anal Chem* **32**:687
123. Koyama T, Thompson TG (1964) *Journal of the Oceanographic Society of Japan* **20**:209
124. Maksimova IV, Pimenova MN (1969) *Mikrobiology* **37**:77
125. Lamar WL, Goerlitz DF (1966) Organic acids in naturally colored surface waters. Water supply paper no. 1817-A:1-17. Geological Survey
126. Horikawa K (1972) *Buseki Kagaku* **21**:806
127. Goncharova IA, Khomenko AN (1971) *Gidrokhim Mater* **53**:36 Ref: Zhur Khim 199D (1970) Abstract No. 59339
128. Borch RF (1975) *Anal Chem* **47**:2437
129. Hoffman NW, Ligo JC (1976) *Anal Chem* **48**:1104
130. Kieber DJ, Vaughan GM, Mopper K (1988) *Anal Chem* **60**:1654
131. Xiao HY, Lee C, Scranton MI (1993) *Anal Chem* **65**:857
132. Kamata E (1966) *Bull Chem Soc Japan* **39**:1227
133. Eberhardt MA, Sieburth JM (1985) *Mar Chem* **17**:199
134. Afghan BK, Kulkarni AU, Leung R, Ryan JF (1974) *Environ Lett* **7**:53
135. Zika RG (1977) An Investigation in marine photochemistry. PhD Dissertation. Dalhousie University
136. Belman S (1963) *Anal Chim Acta* **29**:120
137. Slawinska D, Slawinski J (1975) *Anal Chem* **47**:2101
138. Afghan BK, Kulkarni AU, Ryan JF (1975) *Anal Chem* **47**:488
139. MacKinnon MD (1977) The analysis of the total organic carbon in seawater: a. Development of methods for the quantification of TOC b. Measurement and examination of the volatile fraction of the TOC. PhD Dissertation. Dalhousie University
140. Corwen JP (1970) Volatile organic materials in seawater. In: Hood W (ed) *Organic matter in natural waters*. Publication no. 1. Institute of Mar Sci, University of Alaska, pp 169-170
141. Alekseeva LM (1972) *Trudy gos Oceanogr Inst* **60**:17
142. Goulden PD, Brooksbank P, Day MB (1973) *Anal Chem* **45**:2430
143. Schlungbaum G, Behling A (1974) *Acta Hydroch Hydrob* **2**:423
144. Stilinovic L, Mujko II, Vukic B (1974) *Arh Hig Rada Tokskko* **25**:247
145. Gales ME Jr (1975) *Analyst* **100**:841
146. Wexler AS (1963) *Anal Chem* **35**:1936
147. Fountaine JE, Joshipura PB, Kelihier PN, Johnson JD (1975) *Anal Chem* **46**:62
148. Boyd TJ (1994) *J Chromatogr* **662**:281
149. Katase T (1972) *Kogyo Josui* **1972**:19
150. Corcoran EG (1978) *Environ Heath Persp* **3**:13
151. Giam CS, Chan HS, Neff GS (1975) *Anal Chem* **13**:2225
152. Hites RA (1973) *Environ Heath Persp* **1973**:17
153. Lewis GJ, Rakestraw NW (1955) *J Mar Res* **14**:253
154. Josefsson B, Koroleff F (1976) Polyphenolic substances. In: Grasshoff K (ed) *Methods of seawater analysis*. Verlag Chemie, New York, p 220-227
155. Collier A (1958) *Limnol Oceanogr* **3**:33
156. Josefsson B, Uppstrom L, Ostling G (1972) *Deep-Sea Res* **19**:385
157. Mopper K, Gindler EM (1973) *Anal Chem* **56**:440

158. Johnson KM, Sieburth JMcN (1977) *Mar Chem* 5:1
159. Burney CM, Sieburth JMcN (1977) *Mar Chem* 5:15
160. Hirayama H (1974) *Anal Chim* 70:141
161. Williams PM, Craigie JS (1970) Microdetermination of uronic acids and related compounds in the marine environment. In: Hood DW (ed) *Organic matter in natural waters*. Institute of Marine Science, Publication no. 1. University of Alaska, pp 509–519
162. Mopper K (1977) *Mar Chem* 5:585
163. Hicks SE, Carey FG (1968) *Limnol Oceanogr* 13:361
164. Andrews P, Williams PJ, Leb (1971) *J Mar Biol Assoc* 51:11
165. Whittaker JR, Vallentyne JR (1957) *Limnol Oceanogr* 2:98
166. Degens ET, Reuter JH, Shaw KNF (1964) *Geochim Cosmochim Acta* 28:45
167. Starikova ND, Yablokova OG (1972) *Okeanologiya* 12:431
168. Starikova ND, Yablokova OG (1972) *Okeanologiya* 12:898
169. Geller A (1975) *Archives Hydrobiology* 47:295
170. Josefsson BD (1970) *Anal Chim Acta* 52:65
171. Larsson K, Degens EG (1967) *Microchim Acta* 2:328
172. Mopper K, Degens EG (1972) *Anal Biochem* 45:147
173. Modzeleski JE, Laurie WA, Nagy B (1971) *Geochim Cosmochim Acta* 34:825
174. Tesarik K (1972) *J Chromatogr* 65:295
175. Eklund G, Josefsson B, Roos C (1977) *J Chromatogr* 142:575
176. Williams PJ, Le B (1964) *Limnol Oceanogr* 9:138
177. Sinel'nikov VE, Breusov NG (1973) *Trudy Ins. Biol V nutr Vod, Akad Nauk SSSR* 212
178. Afghan BK, Belliveau PE, Larose RH, Ryan JF (1974) *Anal Chim Acta* 71:355
179. Guilbault GG, Kramer DN, Hackley E (1966) *Anal Chem* 38:1897
180. Goncharova IA, Khomenko AN, Shuk IP (1974) *Gidrokhim Mater* 61:100
181. Chriswell CD, Kissinger LD, Fritz JS (1976) *Anal Chem* 47:1325
182. Kunte H, Slemrova J (1975) *Zeitung Wasserabwasser Forschung* 8:176
183. Kleverlaan NTM (1975) *Chemishe Weekblad* 71:13
184. Cassidy RM, LeGay DS, Frei RW (1974) *J Chromatogr Sci* 12:85
185. Wang LK, Pek SL (1975) *Ing Engng Chem* 14:308
186. Le Bihan A, Courtot-Coupez J (1970) *Bull Chem Soc France* 1:406
187. Hon-Nami H, Hanya T (1980) *Water Res* 14:1251
188. Hon-Nami H, Hanya T (1978) *J Chromatogr* 161:205
189. Wang LK, Yang JY, Wang MH (1973) *Engineering Bulletin Purdue University Engineering External Series* 142:76
190. Wang LK, Yang JY, Wang MH (1975) *J Am Water Works Assoc* 67:6
191. Kozarac Z, Cosovic B, Branica M (1975) *Mar Sci Commun* 1:147
192. Hagihara K (1972) *Kogai Bunseki Shihkin* 5:68
193. Den Tankelaar WAH, Bergshoeff G (1969) *Water Res* 3:31
194. Petts KW, Parkes D (1978) Determination of anionic detergents within a concentration range 0–1 mg/l in sewage effluents and waters by autoanalyser. *Water Research Centre report TR75*
195. Longwell J, Maniece WD (1955) *Analyst* 80:167
196. Abbott DC (1962) *Analyst* 87:286
197. Södergren A (1966) *Analyst* 91:113
198. Favretto L, Tunis F (1976) *Analyst* 101:198
199. Bhat SR, Crisp PT, Eckert JM, Gibson MA (1981) *Anal Chim Acta* 116:191
200. Crisp PT, Eckert JM, Gibson NA (1975) *Anal Chim Acta* 78:391
201. Courtot-Coupez J, Le Bihan A (1969) *Anal Lett* 2:211

202. Le Bihan A, Courtot-Coupez J (1977) *Anal Lett* **10**:759
203. Gagnon MJ (1979) *Water Res* **13**:53
204. Crisp PT, Eckert JM, Gibson NA (1975) *Anal Chim Acta* **87**:97
205. Takano S, Takasake S (1976) *Yukagaku* **25**:31
206. Favretto L, Stancher B, Tunis F (1978) *Analyst* **103**:955
207. Favretto L, Stancher B, Tunis F (1979) *Analyst* **104**:241
208. Favretto L, Stancher B, Tunis F (1980) *Analyst* **105**:833
209. Courtot-Coupez J, Le Bihan A (1969) *Anal Lett* **2**:567
210. Courtot-Coupez J, Le Bihan A (1971) *Riv Ital Sostanza Grasse* **20**:672
211. Grieff O (1966) *Anal Abstr* **13**:3650
212. Crisp PT, Eckert JM, Gibson NA (1979) *Anal Chim Acta* **104**:93
213. Ferguson PL, Iden CR, Brownawell BJ (2000) *Anal Chem* **72**:4322
214. Eklund G, Josefsson B, Roos C (1978) *J High Res Chromatog* **1**:34
215. Eklund G, Josefsson B, Roos C (1977) *J Chromatogr* **142**:575
216. Grob K, Grob G (1970) *J Chromatogr* **125**:471
217. Grob K (1977) *Chromatographie* **10**:181
218. Kaiser KLE, Oliver BG (1976) *Anal Chem* **48**:2207
219. Bellar TA, Lichtenberg JJ, Eichelberger JW (1976) *Environ Sci Technol* **10**:926
220. Grob K (1973) *J Chromatogr* **84**:255
221. Grob K, Zurcher F (1976) *J Chromatogr* **117**:285
222. Grob K, Grob G (1974) *J Chromatogr* **90**:303
223. Grob K, Grob G (1975) *J Chromatogr* **106**:249
224. Westerdorf RG (1982) *International Laboratory September*:32
225. Waggot A, Reid WJ (1977) In: Separation of non-volatile organic compounds in sewage effluent using high-performance liquid chromatography. Part 1. Technical report no. 52. Water Research Centre, Medmenham, UK
226. Bullister JL, Weiss RF (1988) *Deep-Sea Res* **35**:839
227. Dawson R, Riley JP, Tennant RH (1976) *Mar Chem* **4**:83
228. Lovelock JE, Maggs RJ, Wade RL (1973) *Nature* **241**:194
229. Lovelock JE (1975) *Nature* **256**:193
230. Murray AJ, Riley JP (1973) *Nature* **242**:37
231. Murray AJ, Riley JP (1973) *Anal Chim Acta* **65**:261
232. Kristiansen NK, Froeshuag M, Aune KT, Becher G, Lundanes E (1994) *Environ Sci Technol* **28**:1669
233. Friant SL, Suffet JH (1979) *Anal Chem* **51**:2161
234. Cowen WF, Cooper WJ, Highfill JW (1975) *Anal Chem* **47**:2483
235. Gjavotchanoff S, Luessem H, Schlimme K (1971) *Gas-u-Wasser Fach* **112**:448
236. Heydrickx A, Peteghem C (1975) *Eur J Toxicol* **8**:275
237. Chesler SN, Gump BH, Hertz HP (1978) *Anal Chem* **50**:805
238. Dowty B, Green L, Laseter JL (1976) *J Chromatogr Sci* **14**:187
239. Waggot A (1978) In: Proceedings of the Analytical Division of the Chemical Society **15**:232
240. Malter L, Vreden V (1978) *Forum Städte-Hygiene* **29**:37
241. Luessen H (1972) Detection of trace materials by concentration by pressure distillation. *Tech Essen Vortrags Verhöff* **62**
242. Jeüttner F (1994) *Chemosphere* **29**:191
243. Kasthurikrishnan N, Cooke RG (1995) *Talanta* **42**:1325
244. Hashimoto S, Matsuda M, Wakimoto T, Tatsukawa R (1995) *Chemosphere* **30**:1979
245. Park K, Williams WT, Prescott JM, Hood DW (1962) *Science* **138**:331

246. Riley JP, Segar DA (1970) *J Mar Biol Assoc* **50**:713
247. Hosaku K, Maita Y (1971) *Journal of the Oceanographic Society of Japan* **27**:27
248. Starikova ND, Korzhikova RI (1969) *Oceanogiya* **9**:509
249. Lee C, Bada JL (1975) *Earth Planet Sci Lett* **26**:61
250. Zlobin VS, Perlyuk MF, Orlova TA (1975) *Okeanologiya* **15**:643
251. Semenov AD, Ivleva IN, Datsko VG (1964) *Trudy Kommiss, Anal Khim Akad Nauk SSSR* **13**:62
252. Coughenower DD, Curl HC Jr (1975) *Limnol Oceanogr* **20**:128
253. Pocklington R (1971) *Nature* **230**:374
254. Bajor M, Bohling HZ (1970) *Oceanographica Acta* **249**:190
255. Froelich PM, Murphy LD (1977) *Anal Chem* **49**:1606
256. Whiteledge TE, Dugdale RC (1972) *Limnol Oceanogr* **17**:309
257. Hammer KD, Luck S (1987) *Fresen Z Anal Chem* **327**:518
258. Litchfield CD, Prescott JM (1970) *Limnol Oceanogr* **15**:250
259. Roth M (1971) *Anal Chem* **43**:880
260. Bayer E, Grom E, Kaltenecker B, Uhmman R (1976) *Anal Chem* **48**:1106
261. Roth M, Hampai A (1973) *J Chromatogr* **83**:353
262. Felix AM, Terkelsen G (1973) *Arch Biochem Biophys* **157**:177
263. Gardner WS (1975) *Mar Chem* **6**:15
264. Dawson R, Pritchard RG (1978) *Mar Chem* **6**:27
265. Mopper K (1986) *Sci Total Environ* **49**:115
266. Clarke ME, Jackson GA, North WJ (1972) *Limnol Oceanogr* **17**:749
267. Palmark KH (1963) *Acta Chim Scand* **17**:1456
268. Siegal A, Degens ET (1966) *Science* **151**:1098
269. Webb KL, Wood L (1967) Improved techniques for analysis of free amino acids in seawater. In: Scova NB et al. (eds) *Automation in analytical chemistry. Technicon Symposium 1966, Vol. 1. Mediad Inc., New York* pp 440–444
270. Hobbie JE, Crawford CC, Webb KL (1968) *Science* **159**:1463
271. Brockman UH, Eberlein K, Junge HD, et al. (1974) *Entwicklung natürlicher Plankton-Populationen in einem outdoor-tank mit nährstoffarmen Meerwasser. II. Konzentrationsveränderungen von gelösten neutralen Kohlen Meeresforschung. Vol. 6. Springer-Verlag, Berlin*
272. Williams PJ, Le B, Berman T, Holm-Hansen O (1976) *Mar Biol* **35**:41
273. Bohling H (1970) *Mar Biol* **6**:213
274. Bohling H (1972) *Mar Biol* **16**:281
275. Garrasi C, Degens ET (1976) *Analytische Methoden zur säulenchromatographischen Bestimmung von Aminosäuren und Zuckern im Meereswasser und Sediment. Berichte aus dem Projekt DFG-De74/3: "Litoralforschung-Abwasser in Küstennähe". DFG-Abschlusskolloquium, Bremerhaven*
276. Tatsumoto M, Williams WT, Prescott JM, Hood DW (1961) *J Mar Res* **19**:89
277. Pocklington R (1970) *A new method for the determination of amino-acids in sea water and an investigation of the dissolved free amino-acids of North Atlantic Ocean waters. PhD Dissertation. Dalhousie University*
278. Pocklington P (1972) *Anal Biochem* **45**:403
279. Gehrke CW, Lamkin WM, Stalling DL, Shahrokhi F (1965) *Biochem Biophys* **19**:328
280. Gardner WS, Lee GE (1973) *Environ Sci Technol* **7**:719
281. Debeika EV, Fyabov AK, Nabivanets BI (1973) *Gidrobiol Zhur* **9**:109
282. Udenfriend S, Stein S, Bohlen P, Diarman W, Leimgruber W, Weigle M (1972) *Science* **178**:871

283. North BB (1975) *Limnol Oceanogr* **20**:20
284. Parkard TT, Dortch Q (1975) *Mar Biol* **33**:347
285. Baier RM, Goupil DW, Perimutter S, King R (1974) *Journal Rech Atmosphere* **8**:1
286. Pillai TNV, Ganguly AK (1970) *Current Science* **39**:501
287. Hicks E, Riley JP (1980) *Anal Chim Acta* **116**:137
288. Strickland JDH, Solorzano L (1966) Determination of monoesterase hydrolysable phosphate and phosphomonoesterase activity in seawater. Some continued studies in marine science. Springer, Berlin, pp 665–674
289. Maeda M, Taga N (1973) *Mar Biol* **20**:58
290. Batley GE, Florence TM, Kennedy JR (1973) *Talanta* **20**:987
291. Di Corcia A, Samperi F (1974) *Anal Chem* **46**:977
292. Varney MS, Preston MR (1985) *J Chromatogr* **348**:265
293. Petty RL, Michel C, Snow JP, Johnson KS (1982) *Anal Chim Acta* **142**:299
294. Yang XH, Lee C, Scranton MI (1991) *Anal Chem* **65**:572
295. Florence TM, Farner YJ (1973) *Anal Chim Acta* **63**:255
296. Hashimoto A, Sakino H, Yamagami E, Tateishi S (1980) *Analyst* **105**:787
297. Hashimoto A, Kozima T, Sakino H, Ankey T (1979) *Water Res* **13**:509
298. Barshick S-A, Griest WH (1998) *Anal Chem* **70**:3015
299. Shinohara R, Kido A, Okamoto Y, Takeshita R (1983) *J Chromatogr* **256**:81
300. Junk GA, Richard JJ, Grieser D, Witiak D, Witiak JL, Arguello MD, Vick R, Svec HJ, Fritz JS, Calder GV (1974) *J Chromatogr* **99**:745
301. Emmet RT (1969) Spectrophotometric determination of urea in natural waters with hypochlorite and phenol. NAVSHIPRANDLAB Annapolis Report 2663
302. Newell BS, Morgan B, Cundy J (1967) *J Mar Res* **25**:201
303. Muravskaya ZA (1973) *Gidrobiol Zhur* **9**:127
304. DeMarche JM, Curl H Jr, Coughenower DD (1973) *Limnol Oceanogr* **18**:686
305. Mitamura O, Osaka K (1987) *Daigaku Kiyo Dai-3-bumon* **36**:159
306. Von Breymann, de Angelis MA, Gordon LI (1982) *Anal Chem* **54**:1209
307. Brown L, Rhead M (1979) *Analyst* **104**:391
308. Stolzberg PJ (1977) *Anal Chim Acta* **92**:139
309. Lovelock JE, Maggs RJ, Rasmussen RA (1972) *Nature* **237**:452
310. Yamavka V, Tanimoto T (1976) *J Agr Chem Soc* **50**:147
311. Leck C, Baagander LE (1988) *Anal Chem* **60**:1680
312. Charlson RJ, Lovelock JE, Andreae MO, Warren SG (1987) *Nature* **326**:655
313. Malin G, Turner S, Liss PS, Holligan P, Harbour D (1993) *Deep-Sea Res* **40**:1487
314. Turner SM, Malin G, Liss PS, Harbour DS, Holligan PM (1988) *Limnol Oceanogr* **33**:364
315. Turner SM, Malin G, Liss PS (1989) In: Saltzman E, Cooper WJ (eds) *Biogenic sulfur in the environment*. ACS symposium series no. 393. American Chemical Society, Washington, DC, pp 183–200
316. Holligan PM, Turner SM, Liss PS (1987) *Cont Shelf Res* **7**:213
317. Keller MD, Bellows WK, Guillard RRL (1989) In: Saltzman E, Cooper WJ (eds) *Biogenic sulfur in the environment*. ACS symposium series no. 393. American Chemical Society, Washington, DC, pp 167–182
318. Stefels J, van Boekel WHM (1993) *Mar Ecol Prog Ser* **97**:11
319. Challenger F, Simpson MI (1948) *J Chem Soc* **3**:1591
320. Ledyard KM, Dacey JWH (1994) *Mar Ecol Prog Ser* **110**:95
321. Smith GC, Clark T, Knutsen L, Barrett E (1999) *Anal Chem* **71**:5563
322. Shea D, McCrehan WA (1988) *Anal Chem* **60**:1449
323. Duare LM, Stock JT (1978) *Anal Chem* **50**:1891

324. Andreae MO (1980) *Anal Chem* **52**:150
325. Andreae MO (1977) *Anal Chem* **49**:820
326. Capitan F, Alonso E, Avidan R, Capitan-Vallvey LF, Vilchez JL (1993) *Anal Chem* **65**:1336
327. Van den Berg CMG, Househam BC, Riley JP (1988) *J Electroanal Chem-Interfacial Electrochemistry* **239**:137
328. Turner SM, Nightingale PD, Broadgate W, Liss PS (1995) *Deep-Sea Res Part II: Topical Studies in Oceanography* **42**:1059
329. Wanatabe S, Demura K, Tsunogai S (1987) *Hokkaido Daigaku Suisan Gabuku Kenkyo Iho* **38**:288
330. Przyjazny A (1988) *J Chromatogr A* **346**:61
331. Savchuk SA, Rudenko BA, Brodskii ES, Soifer VS (1995) *J Anal Chem* **50**:1081 (Translated from *Zhur Anal Khim*)
332. Wilson AJ, Forester J (1974) US Environmental Protection Agency Report No. EPA-600-7-74, p 108
333. Wilson AJ, Forester J, Knight J (1969) US Fish Wildlife Service Circular 355, 18–20, Centre for Estuaries and Research, Gulf Breeze, Florida, USA
334. US Environmental Protection Agency Analytical Quality Control Laboratory, US Government Printing Office, Washington DC (1972)
335. Wilson AJ, Forester JJ (1971) *Association of the Officers in Analytical Chemistry* **54**:525
336. Picer IV, Picer M, Strohal P (1975) *Bull Environ Contam Tox* **14**:565
337. Wilson AJ (1976) *Bull Environ Contam Tox* **15**:515
338. Aspila KI, Carron JH, Chau ASY (1977) *Journal of the Association of Official Analytical Chemists* **60**:1097
339. *Analytical Methods Manual* (1974) Inland Water Directorate Water Quality Branch Ottawa Ontario Canada
340. Miles JR, Tu CM, Harris OR (1969) *J Econ Ent* **62**:1334
341. Chau ASY, Rosen JD, Cochrane WB (1971) *Bull Environ Contam Tox* **6**:225
342. Chau ASY (1974) *Journal of the American Oil and Colours Association* **57**:585
343. Thompson JE (1974) *Analysis of Pesticide Residues in Human and Environmental Samples*, US Environmental Protection Agency, Research Triangle Park, US Environmental NC Sec 10A DG
344. Eichellberger JW, Lichtenberg JL (1971) *Environ Sci Technol* **5**:541
345. Samuelsen OB (1987) *Aquaculture* **60**:161
346. Zitko V, Choi P (1971) PCB and Other Industrial Halogenated Hydrocarbons in the Environment. Fish Research Board Ottawa Canada Technical Report No. 272 Biological Station St Andrews NB
347. Oller WL, Cramwer MF (1975) *J Chromatogr Sci* **13**:296
348. Edwards R (1970) *Chem Ind - London* 1340
349. Fishbein L (1972) *J Chromatogr* **68**:345
350. Schulte E, Their HP, Acker L (1976) *Deut Lebensmittel Rundschau* **72**:229
351. Goke G (1975) *Deut Lebensmittel Rundschau* **71**:309
352. Ashling B, Jensen S (1970) *Anal Chem* **42**:1483
353. Musty PR, Nickless G (1974) *J Chromatogr* **89**:185
354. Girenko DB, Klisenko MA, Dishcholka YK (1975) *Hydrobiological Journal* **11**:60
355. Elder D (1976) *Mar Pollut Bull* **7**:63
356. Harvey GR (1973) Report of the US Environment Protection Agency, EDA-R2-73-177
357. Picer N, Picer M (1980) *J Chromatogr* **193**:357
358. Holden AV, Marsden K (1969) *J Chromatogr* **44**:481
359. Snyder DE, Reinert RE (1971) *Bull Environ Contam Tox* **6**:385

360. Picer M, Abel M (1978) *J Chromatogr* **150**:1191
361. Hernandez Garcia J, Sosa Ferrera Z, Bermejo Martin-Lázaro AJ, Santana Rodriguez JJ (1994) *Anal Lett* **27**:1355
362. Hernandez Garcia J, Betancort Rodriguez JR, Bermejo Martin-Lázaro AJ, Santana Rodriguez JJ (1994) *Anal Chim Acta* **290**:146
363. Petrick G, Schulz DE, Duinker JC (1988) *J Chromatogr* **435**:241
364. Pedersen-Bjergaard S, Semb SI, Vedde J, Brevik EM (1996) *Chromatographia* **43**:44
365. Leoni V, Pucelti G, Grella AJ (1975) *J Chromatogr* **106**:119
366. Leoni V (1971) *J Chromatogr* **62**:63
367. Johnston LV (1965) *Journal of Association of Official Analytical Chemists* **48**:668
368. Claeys RR, Inman RD (1974) *Journal of Association of Official Analytical Chemists* **57**:399
369. Leoni V, Pucetti G (1969) *J Chromatogr* **43**:388
370. Leoni V, Pucetti G, Columbo RJ, Oviddo O (1976) *J Chromatogr* **125**:399
371. Millar JD, Thomas RE, Schatterberg HJ (1981) *Anal Chem* **53**:214
372. Kelly AG, Cruz I, Wells DE (1993) *Anal Chim Acta* **276**:3
373. Boyd TJ (1994) *J Chromatogr* **662**:281-92
374. Sullivan KF, Atlas EL, Giam C-S (1981) *Anal Chem* **53**:1718
375. Petrick G, Sculz-Bull DE, Martens V, Scolz K, Duinker JC (1996) *Mar Chem* **54**:97
376. Minear RA (1972) *Environ Sci Technol* **6**:431
377. Minear RA, Walanski KA (1974) Investigation of the chemical identity of soluble organophosphorus compounds found in natural waters. Research report UILU-WRC-74-0086
378. McElvroy WD, Strehler BL (1949) *Arch Biochem* **22**:420
379. Wildish DJ (1976) Determination of adenosine 5'-triphosphate in estuarine water and sediments by firefly bioluminescence assay. Technical report of the fisheries maritime service research division, no. 649
380. Hofer-Siegrist L, Schweiz A (1976) *Hydrology* **38**:49
381. Weber K (1976) *Water Res* **10**:237
382. Lores EM, Moore JC, Knight J (1985) *J Chromatogr Sci* **23**:124
383. Daughton CG, Crosby DC, Garnes RL, Hsieh DPH (1976) *J Agr Food Chem* **24**:236
384. Michel HO, Gordon EC, Epstein J (1973) *Environ Sci Technol* **7**:1045
385. Cembella AD, Antia NJ (1986) *Mar Chem* **19**:205
386. Ahern F, Eckert JM, Hain SF, Leggett KEA, Payne NC, Williams KL (1987) *Anal Chim Acta* **199**:259
387. Grift N, Lockhart WL (1974) *Journal of the Association of Official Analytical Chemists* **57**:1282
388. Wu TL, Lambert L, Hastings D, Banning D (1980) *Bull Environ Contam Tox* **24**:411
389. Abel M, Evans KM, Fileman TW, Mantoura RFC (1992) *Anal Chim Acta* **268**:195
390. Durand G, Barcelo D (1993) *Talanta* **40**:1665
391. Molina C, Durand G, Barcelo D (1995) *J Chromatogr A* **712**:113
392. Barcelo D, Durand G, Bouvet V, Nielen M (1973) *Environ Sci Technol* **7**:271
393. Durand G, Chiron S, Bouvet V, Barcelo D (1992) *Int J Environ Anal Chem* **49**:31
394. Ferrer I, Barcelo D (1999) *J Chromatogr A* **854**:197
395. Paradis M, Ackman RG (1977) *Journal of the Fisheries Research Board, Canada* **34**:2156
396. Lewis RW (1969) *Limnol Oceanogr* **14**:35
397. Lee RF, Nevenzei JC, Pattenhofer GA (1971) *Mar Biol* **9**:99
398. Volimirov B (1982) *Mar Ecol* **3**:97
399. Olsen CR, Cutshall NH, Larsen TL (1982) *Mar Chem* **11**:501

400. Whittle KJ, Hardy R, Mackie PR, McGill AS (1982) *Philos T Roy Soc B* **297**:193
401. Simkiss K (1983) *Journal of the Marine Biological Association, UK* **63**:1
402. Florence TM, Lumsden BG, Fardy J (1983) *Anal Chim Acta* **151**:281
403. Parrish CC, Ackman RG (1983) (1983) *J Chromatogr A* **262**:103
404. Delmas RP, Parrish CC, Ackman RG (1984) *Anal Chem* **56**:1272
405. Wun CK, Walker RW, Litsky W (1976) *Water Res* **10**:955
406. Dutka BT, Chau ASY, Coburn J (1974) *Water Res* **8**:1047
407. Wun CK, Walker RW, Litsky W (1978) *Health Lab Sci* **15**:67
408. Adams DD, Richards RA (1960) *Deep-Sea Res* **15**:471
409. Belyaeva AN (1974) *Okeanologiya* **14**:1101
410. Matthews SW, Smith LL (1968) *Lipids* **3**:239
411. Smith LL, Gouron RE (1969) *Water Res* **3**:141
412. Saliot A, Barbier M (1973) *Deep-Sea Res* **20**:1077
413. Saliot A, Barbier M (1973) *Advances in Organic Geochemical Procedures Institute Meeting*. In: *Proc Mtg US Geochemical Institute*, pp 607–617
414. Matsushima H, Wakimoto T, Tatsukawa R (1975) *Japan Analyst* **24**:342
415. Gagosian RB (1975) *Geochim Cosmochim Acta* **39**:1443
416. Attaway D, Parker PL (1970) *Science* **169**:674
417. Kanazawa A, Teshima SI (1971) *Journal of the Oceanographic Society of Japan* **27**:207
418. Hanck KW, Dillard JW (1977) *Anal Chem* **49**:404
419. Stolzberg RJ, Rosin D (1977) *Anal Chem* **49**:226
420. Chau YK, Gachter R, Lum-Shue-Chan K (1974) *Journal of the Fisheries Research Board of Canada* **31**:1515
421. Buffle J, Greter F-L, Haerdi W (1977) *Anal Chem* **49**:216
422. Jones DR, Mahahan SE (1975) *Anal Lett* **8**:421
423. Jones DR, Mahahan SE (1976) *Anal Chem* **48**:502
424. Kaiser KLE (1973) *Water Res* **7**:1465
425. Egan WG (1974) *Journal of the Marine Technical Society* **8**:40
426. Ghassemi M, Christman RF (1968) *Limnol Oceanogr* **13**:583
427. Gjessing ET (1970) *Environ Sci Technol* **4**:437
428. Brown W (1975) *Mar Chem* **3**:253
429. Wangersky PJ (1978) *Production of dissolved organic matter*. In: *Marine Ecology* (ed. Kinne O), Vol. 4, John Wiley, New York
430. Sieburth JMcN, Jensen A (1968) *J Exp Mar Biol Ecol* **2**:174
431. Sieburth JMcN, Jensen A (1969) *J Exp Mar Biol Ecol* **3**:275
432. Pocklington R, Hardstaff WR (1974) *Journal of the International Conference on Exploration of the Sea* **36**:92
433. Stoeber H, Eberle SH (1974) *Organic Acids in the Rhine and Some of its Tributaries*. Kernforschungszentrum Karlsruhe, KFK 1969 UF, pp 58–81
434. Revina SK, Kriul'kov VA (1972) *Trudy Gos Oceanographic Institute* **113**:42
435. Bilikova A (1973) *Vod Hospod B* **23**:44
436. Kloster MB (1975) *J Am Water Works Assoc* **66**:44
437. Bilikova A (1974) *Vod Hospod B* **24**:20
438. Eberle SH, Hoesle C, Krueckeberg C (1974) *New method for simultaneously determining lignosulphonic acid and humic acid in water, using differential pulse polarography*. Kernforschungszentrum Karlsruhe, KFK 1969 UF, pp 44–57
439. Paluch J, Stangret S (1972) *Fortschr Wasserchem Ihrer Grenzgeg* **14**:89
440. Pocklington R, MacGregor CD (1973) *Int J Environ Anal Chem* **3**:81
441. Almgren T, Josefsson B (1973) *Sveridge Papperstidn* **76**:19

442. Wilander A, Kvarnas H, Lindel T (1974) *Water Res* **8**:1037
443. Almgren T, Josefsson B, Nyquist G (1975) *Anal Chim Acta* **78**:411
444. Kononova MM (1966) In: *Soil Organic Matter* Pergamon Press New York
445. King LH (1967) Isolation and Characterization of Organic Matter from Glacial-Marine Sediments on the Scotian Shelf. Report BIO 67-4, pp 1–18
446. Rashid MA, King LH (1969) *Geochim Cosmochim Acta* **33**:147
447. Pierce RH Jr, Felbeck GT Jr (1972) A comparison of three methods of extracting organic matter from soils and marine sediments. In: Povoledo D, Golterman HL (eds) *Humic Substances*. Center for Agriculture Publication and Documentation, Wageningen, Netherlands, pp 217–232
448. Stuermer DH, Harvey GR (1974) *Nature* **250**:480
449. Stuermer DH, Harvey GR (1977) *Deep-Sea Res* **24**:303
450. Mantoura RFC, Riley JP (1975) *Anal Chim Acta* **76**:97
451. Stuermer DH, Payne JR (1976) *Geochim Cosmochim Acta* **40**:1109
452. Schnitzer M (1972) Chemical, spectroscopic, and thermal methods for the classification and characterization of humic substances. In: Povoledo D, Golterman HL (eds) *Humic Substances*. Center for Agriculture Publication and Documentation, Wageningen, Netherlands, pp 293–310
453. Salfeld JC (1972) Ultraviolet and visible absorption spectra of humic systems. In *Humic Substances* (eds Povoledo D, Golterman HL), Center for Agriculture Publications and Documentation, Wageningen, The Netherlands, p. 269–280
454. Generalova VA (1974) *Gidrokhim Mater* **60**:186
455. Sil'chenko SA, Rubinshtein RN, Vasileva LN (1972) *Zhur Analytical Khim* **27**:2465
456. Manka J, Rebhun M, Mandelbaum A, Bortinger A (1974) *Environ Sci Technol* **8**:1017
457. Schnitzer M, Skinner SIM (1974) *Can J Chem* **52**:1072
458. Skinner SIM, Schnitzer M (1975) *Anal Chim Acta* **75**:207
459. Strickland JDH, Parsons TR (1972) *A Practical Handbook of Seawater Analysis*. 2nd edition, Bulletin of the Fisheries Research Board of Canada, No. 067
460. Strickland JDH, Parsons TR (1972) Determination of soluble organic carbon. In: Goldberg ED (ed) *A guide to marine pollution*. Gordon and Breach Science Publishers, New York, pp 70–76
461. Rai H (1973) *Theoretical Angerolimnology* **18**:1864
462. Messiha-Hanna RG *Okeanologiya* **13**:704
463. Quirry MR, Holland WE, Waring RC, Hale GM (1975) High sensitivity laser absorption spectroscopy of laboratory aqueous solutions and of natural Missouri waters. PB report no. 243123, US National Technical Information Service, Springfield, VA, USA
464. Bjarnborg B (1979) Report No. 1239, P22ABJA, Swedish Environmental Protection Board, Solna, Sweden
465. Boto KG, Bunt TS (1978) *Anal Chem* **50**:392
466. Murray AP, Gibbs CF, Longmore AR, Flett DJ (1986) *Mar Chem* **19**:211
467. Abayashi JK, Riley JP (1979) *Anal Chim Acta* **107**:1
468. Garside C, Riley JP (1969) *Anal Chim Acta* **46**:179
469. Karabashev GS (1992) *Oceanographia Acta* **15**:255
470. Ryther JH, Guillard RRL (1962) *Can J Microbiol* **8**:437
471. Ohwada K, Otshhata M, Taga N (1972) *Bulletin of the Japanese Society of Fish Science* **28**:817
472. Gold K (1964) *Limnol Oceanogr* **9**:343
473. Carlucci AF, Silbernagel SB (1966) *Can J Microbiol* **12**:175
474. Natarajan KV, Dugdale RC (1966) *Limnol Oceanogr* **11**:621

475. Natarajan KV (1968) *Appl Microbiol* **16**:366
476. Litchfield CD, Hood DW (1965) *Appl Microbiol* **13**:886
477. Ohwada K (1972) *Mar Biol* **14**:10
478. Carlucci AF, Silbernagel SB (1967) *Can J Microbiol* **13**:979
479. Sharma GM, DuBois HR, Pastore AT, Bruno SF (1979) *Anal Chem* **51**:196
480. Suzucki T, Mitsuya T, Matsubara H, Yamasaki M (1998) *J Chromatogr A* **815**:155
481. Vastano SE, Milne PJ, Stahoec WL, Mopper K (1987) *Anal Chim Acta* **201**:127
482. Brown RA, Searl TD, Elliott JJ et al. (1973) Distribution of heavy hydrocarbons in some Atlantic waters. In: Proceedings of the conference on prevention and control of oil spills. American Petroleum Institute, Washington, DC, pp 509–519
483. Hites RA, Biemann K (1972) *Science* **178**:158
484. Hites RA, Biemann WG (1975) Identification of specific organic compounds in a highly anoxic sediment by gas chromatographic-mass spectrometry and high resolution mass spectrometry. In: Gibb RP Jr (ed) *Analytical methods in oceanography*. American Chemical Society, Washington, DC, pp 188–201
485. Mengerhauser JV (1973) Crystal microbalance for determination of oil in water. AD report no. 762107US. National Technical Information Service, Springfield, VA, USA
486. Bieri RH, Walerk AL, Lewis BW et al. (1974) Identification of hydrocarbons in an extract from estuarine water accommodated no. 2 fuel oil. Special publication no. 409. National Bureau of Standards, Washington, DC, p 149
487. Hertz HS, Chesler SN, May WE et al. (1974) Methods for trace organic analysis in sediments and marine organisms. Special publication no. 409. National Bureau of Standards, Washington, DC, p 197
488. Cretney WJ, Johnson WK, Wong CS (1977) Trace analysis of oil in sea water by fluorescence spectroscopy. Unpublished manuscript. *Pacific Mar Sci Report*, pp 77–75
489. Barbier M, Joly D, Saliot A, Tourres D (1973) *Deep-Sea Res* **20**:305
490. Zobova NA (1973) *Okhr Ikh Resur* **4**:45
491. Matsushima H, Hanya T (1975) *Bunseki Kagaku* **24**:505
492. Maxmanidi ND, Kovaleva GI, Zobova NS (1974) *Okeanologiya* **15**:453
493. Hellman H (1976) *Zeitschrift fur Analytische Chemie* **278**:263
494. Hughes DR, Belcher RS, O'Brien EJ (1973) *Bull Environ Contam Tox* **10**:170
495. Majori L, Petronio F, Nedoclan G (1973) *Ig Mod* **66**:150
496. Ahmed SM, Beasley MD, Efromson AC, Hites RA (1974) *Anal Chem* **46**:1858
497. Brown RA, Elliott JJ, Searl TD (1974) Measurement and characterisation of non-volatile hydrocarbons in ocean water. Special publication no. 409. National Bureau of Standards, Washington, DC, p 131
498. Mallevalle J (1974) *Water Res* **8**:1071
499. Brown RA, Elliott JJ, Kelliher JM, Searl TD (1975) Sampling and analysis of non-volatile hydrocarbons in ocean water. In: Gibb RP Jr (ed), *Analytical Methods in Oceanography*, American Chemical Society, Washington, pp 172–187
500. LeRoux JH (1975) Instrument for detecting and measuring trace quantities of hydrocarbons in water. South African Patent No. 02.379 (C1 BOID GOIF)
501. Zsolnay A (1973) *Chemosphere* **2**:253
502. Zsolnay A (1974) Determination of aromatic and total hydrocarbon content in submicrogram and microgram quantities in aqueous systems by means of high-performance liquid chromatography. Special publication no. 409. National Bureau of Standards, Washington, DC, p 119
503. Zsolnay A (1974) *J Chromatogr* **90**:79

504. Ellis DW (1979) Analysis of aromatic compounds in water using fluorescence and phosphorescence. PB report no. 212268. National Technical Information Service, Springfield, VA, USA
505. Mackie PR, Whittle KJ, Hardy R (1974) *Mar Sci* **2**:359
506. Simeoneit BR, Smith DH, Eglinton G, Burlingame AL (1973) *Arch Environ Contam Toxicol* **1**:193
507. Blaylock JW, Bean RM, Wildung RE (1974) Determination of extractable organic material and analysis of hydrocarbon types in lake and coastal sediments. Special publication no. 409. National Bureau of Standards, Washington, DC, p 217
508. Jeffrey LM, Rasby BF, Stevenson B, Hood DW (1964) Lipids of ocean water. In: Colombo U, Hobson GD (eds) *Advances in organic geochemistry*. Pergamon Press, Oxford, pp 175–197
509. Law RJ, Marchand M, Dahlmann G, Fileman TW (1987) *Mar Pollut Bull* **18**:486
510. Hiraide M, Ren FN, Tamura R, Mizuike A (1987) *Mikrochimica Acta* **416**:137
511. Husser ER, Stehl RH, Price DR, De Lap RA (1977) *Anal Chem* **49**:154
512. Tatsumo M, Williams TJ, Prescott JM, Hood DW (1961) *J Mar Res* **19**:89
513. Degens ET, Reuter JH, Shaw KNF (1964) *Geochim Cosmochim Acta* **28**:47
514. Rittenberg SC, Emery KO, Hulsemann J, Degens ET, Fay RC, Reuter LH, Grady JR, Richardson SH, Bray EE (1963) *Sediment Petrol* **33**:140
515. Webb KL, Wood L (1967) Improved techniques for analysis of free amino acids in seawater In: *Automation in Analytical Chemistry* (Technicon Symposium 1966) (eds Scova NB et al.) New York Mediad Inc., Vol. 1, p 440–446
516. Crawford CC, Hobbie TE, Webb KL (1974) *Ecology* **55**:551
517. Brockmann UH, Eberlein K, Junge HD, Majer-Reimer E, Siebers D, Trageser H (1974) Entwicklung natürlicher Planktonpopulationen in einem outdoor-Tank mit nährstoffarmem Meerwasser. II. Konzentrationsveränderungen von gelösten neutralen Kohlenhydraten und freien gelösten Amino-säuren. Berichte aus dem Sonderforschungsbereich Meeresforschung, SFB94. Universität Hamburg **6**:166
518. Dawson R, Mopper K (1977) *Anal Biochem* **83**:100
519. Lee C, Bada JL (1977) *Limnol. Oceanog* **22**:502
520. Daumas RA (1976) *Mar Chem* **4**:225
521. Dawson R, Gocke K (1977) *Oceanol Acta* **1**:80
522. Chian ESK, Bruce WN, Fang HHP (1975) *Environ Sci Tech Technology* **9**:52
523. Klein E, Eichelberger J, Eyer C, Smith J (1975) *Water Res* **9**:807
524. Harvey GR (1972) Absorption of chlorinated hydrocarbon from seawater by a crosslinked polymer, Woods Hole, MA, USA
525. Sackmauereva M, Pal'usova O, Szokalay A (1977) *Water Res* **11**:551
526. Leoni V, Pucetti G, Grella A (1975) *J Chromatogr* **106**:119
527. Riley JP, Taylor D (1969) *Anal Chim Acta* **46**:307
528. Osterroht C (1972) *Kiel Meerseforsch* **28**:48
529. Sauer WA, Jadamec JR, Sagar RW, Killeen TJ (1979) *Anal Chem* **51**:2180
530. Chapman G, Rao AC (1967) *Nature* **214**:627
531. Bertsch W, Anderson E, Holzer G (1975) *J Chromatogr* **112**:701
532. Dravnieks A, Krotoszynski BK, Whitfield J, O'Donnell A, Burgwald T (1971) *Environ Sci Tech* **5**:1220
533. Novak J, Zluticky J, Kubelka V, Mostecky J (1973) *J Chromatogr* **76**:45
534. The Oil Companies International Study Group for Conservation of Clean Air and Water, Europe (1982) In: *Analysis of trace substances in aqueous effluents from petroleum refineries*. Concauwe report no. 6/82

535. Ochsenkuhn-Petsopolu M, Ochsenkuhn KM, Darusaikis G, Glannakis AN, Smith HD (1995) *Can J Appl Spectros* **40**:66
536. Nagase T, Tao H, Imagawa T, Miyazaki A (1992) *Shigen to Kankyo* **1**:263
537. Schintu M, Kauri T, Contu A, Kudo A (1987) *Ecotox Environ Safe* **14**:208
538. Burgess RM (2000) *Int J Environ Pollut* **13**:2
539. Fuoco R, Ceccarini A, Onor M, Marrara L (1999) *J Chromatogr* **846**:387
540. Law RJ, Klingsoyr R (2000) *Int J Environ Pollut* **13**:262
541. Frank H, Cristoph EH, Holm-Hanson O, Bullister JL (2002) *Environ Sci Technol* **36**:12
542. Riu J, Eichhorn P, Guerrero JA, Knepper TP, Barcolo D (2000) *J Chromatogr* **889**:221
543. Metcalfe JS, Bell SG, Codd GA (2000) *Water Res* **34**:2761

10 Organometallic Compounds

10.1

Organoarsenic Compounds

Large amounts of arsenic enter the environment each year because of the use of arsenic compounds in agriculture and industry as pesticides and wood preservatives. The main amount is used as inorganic arsenic (arsenite, arsenate), and about 30% as organoarsenicals such as monomethylarsinate and dimethylarsinate. Arsenic is known to be relatively easily transformed between organic and inorganic forms in different oxidation states by biological and chemical action [1, 2]. Until recently, most of the analytical work has been concerned only with the total content of arsenic. But as the toxicity and biological activity of the different species vary considerably, information about the chemical form is becoming of great importance in environmental analysis.

Arsenic being present in inorganic form and as a variety of organic compounds implies the use of analytical strategies which use physical and chemical separations, as well as general or specific detectors. Since the lower molecular weight organic arsenic compounds, as well as some inorganic arsenic compounds, are easily vapourised, both gas chromatography and direct vapour generation atomic absorption are favoured analytical methods.

A review of the analytic chemistry of arsenic in the sea, including occurrence, analytical methods, and the establishment of analytical standards, has been published [3].

Earlier investigations have shown that the major known organic arsenic compound in the environment is dimethylarsinate. For that reason, specific and sensitive methods for the determination of this compound are needed. Several methods exist for this determination, often together with other arsenic species. Hydride generation and selective vaporisation of cold-trapped arsines in combination with various detection systems seem to be the methods most frequently used [4–6]. These methods are applicable to the species As^{III} , As^{V} , monomethylarsinates, dimethylarsinate, and trimethylarsine oxide. The optimum conditions for generation of the respective arsine are, however, different for all these species with regard to the pH of the generating solution [7, 8]. These methods also suffer from interferences from numerous inorganic ions [9]. Preconcentration in a toluene cold-trap following arsine generation was suc-

cessful for monomethyl arsinates and dimethyl arsinates, but nonquantitative recoveries of dimethylarsinate were reported, probably because of the problem mentioned above with the arsine generation step. Molecular rearrangements occurring during arsine generations are, however, reported to be minimised if sodium tetrahydroborate is introduced as a pellet [10]. To simplify the determination of the different species, improved separation of the arsines using gas chromatography may be necessary.

10.1.1

Atomic Absorption Spectrometry

The simplest analytical method is direct measurement of arsenic in volatile methylated arsenicals by atomic absorption [11]. A slightly more complicated system, but one that permits differentiation of the various forms of arsenic, uses reduction of the arsenic compounds to their respective arsines by treatment with sodium borohydride. The arsines are collected in a cold trap (liquid nitrogen), then vaporised separately by slow warming, and the arsenic is measured by monitoring the intensity of an arsenic spectral line, as produced by a direct current electrical discharge [1, 12, 13]. Essentially the same method was proposed by Talmi and Bostick [10] except that they collected the arsines in cold toluene (-5°C), separated them on a gas chromatography column, and used a mass spectrometer as the detector. Their method had a sensitivity of $0.25\ \mu\text{g/l}$ for water samples.

Another variation on the method [4] with slightly higher sensitivity (several ng/l) used the liquid nitrogen cold trap and gas chromatography separation, but used the standard gas chromatography detectors or atomic absorption for the final measurement. These workers found four arsenic species in natural waters.

Persson and Irgum [14] fulfilled a requirement to determine sub ppm levels of dimethyl arsinates by preconcentrating the organoarsenic compound on a strong cation exchange resin (Dowex AG 50 W-XB). By optimising the elution parameters, dimethyl arsinates can be separated from other arsenicals and sample components, such as group I and II metals, which can interfere in the final determination. Graphite furnace atomic absorption spectrometry was used as a sensitive and specific detector for arsenic. The described technique allows dimethylarsinate to be determined in a sample (20 ml) containing a 10^5 -fold excess of inorganic arsenic with a detection limit of $0.02\ \mu\text{g As/l}$.

The results show that good recoveries were obtained from artificial seawaters, even at the $0\text{--}05\ \mu\text{g/l}$ level, but for natural seawater samples the recoveries were lower (74–85%). This effect could be attributed to organic sample components that eluted from the column together with dimethyl arsinates.

10.1.2 Spectrophotometric Method

In the method for [17] inorganic arsenic the sample is treated with sodium borohydride added at a controlled rate (Fig. 10.1). The arsine evolved is absorbed in a solution of iodine and the resultant arsenate ion is determined photometrically by a molybdenum blue method. For seawater the range, standard deviation, and detection limit are 1–4 $\mu\text{g/l}$, 1.4%, and 0.14 $\mu\text{g/l}$, respectively; for potable waters they are 0–800 $\mu\text{g/l}$, about 1% (at 2 $\mu\text{g/l}$ level), and 0.5 $\mu\text{g/l}$, respectively. Silver and copper cause serious interference at concentrations of a few tens of mg/l; however, these elements can be removed either by preliminary extraction with a solution of dithizone in chloroform or by ion exchange.

The precision of the method was tested by carrying out replicate analyses (10) on 150 ml aliquots of two seawater samples from the Irish Sea. Mean (\pm sd) arsenic concentrations of 2.63 ± 0.05 and 2.49 ± 0.05 $\mu\text{g/l}$ amounts of were found. The recovery of arsenic was checked by analysing 150 ml aliquots of arsenic-free seawater which had been spiked with known amounts of arsenic (V). The results of these experiments shows that there is a linear relationship between absorbance and arsenic concentration and that arsenic could be recovered from seawater with an average efficiency of 98.0% at levels of 1.3–6.6 $\mu\text{g/l}$. Analogous experiments in which arsenic (III) was used gave similar recoveries.

Although purely thermodynamic considerations suggest that arsenic should exist in oxic seawaters practically entirely in the pentavalent state, equilibrium

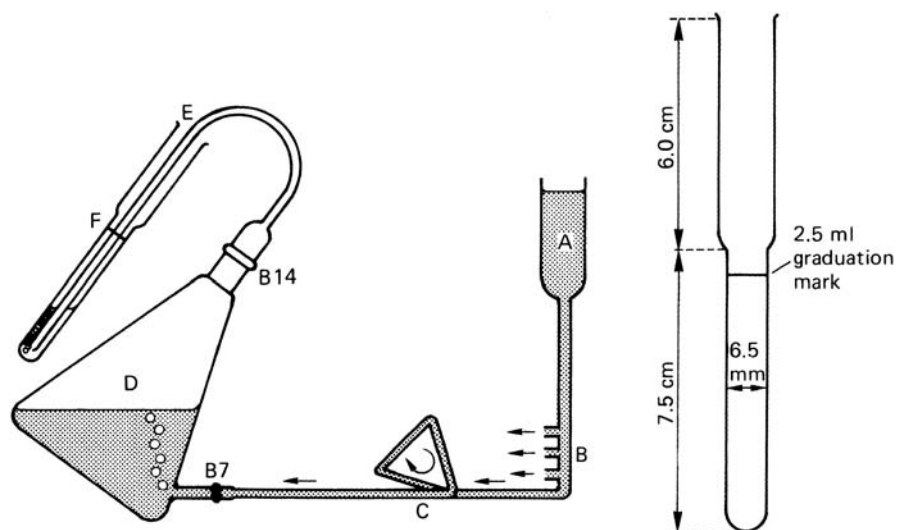

Figure 10.1. Apparatus for the evolution and trapping of arsenic. The dimensions of the absorption tube F are given in the inset. Source: [17]

rarely appears to be attained, probably because of the existence of biologically mediated reduction processes. For this reason, the arsenic in most of these waters exists to an appreciable extent in the trivalent state, and $\text{As}^{\text{III}}:\text{As}^{\text{V}}$ ratios as high as 1–1 have been found in a number of instances.

Haywood and Riley [17] found that arsenic (III) can be separated from arsenic (V) even at levels of $2\ \mu\text{g}/\text{l}$ by extracting it as the pyrrolidine dithiocarbamate complex with chloroform. They applied this technique to samples of seawater spiked with arsenic (V) and arsenic (III) and found that arsenic (V) could be satisfactorily determined in the presence of As^{III} .

10.1.3

Miscellaneous Methods

It is also possible to separate the organic arsenic compounds by column chromatography first, and then reduce them to arsines later [16].

Organic arsenic species can be rendered reactive either by photolysis with ultraviolet radiation or by oxidation with potassium permanganate or a mixture of nitric acid and sulfuric acids. Arsenic (V) can be determined separately from total inorganic arsenic after extracting arsenic (III) as its pyrrolidine dithiocarbamate into chloroform [15].

The nature of refractory methylarsenic compounds in estuary waters has been examined by desorption chemical ionisation mass spectrometry, and mass spectrometry [18].

10.2

Organocadmium Compounds

10.2.1

Anodic Scanning Voltammetry

Until 1996 organocadmium compounds had not been detected in the environment.

Pongratz and Hunmann [19], using differential pulse anodic scanning voltammetry, found low levels of methyl cadmium compounds in the Atlantic Ocean. Levels in the South Atlantic were approximately $700\ \text{pg}/\text{l}$, and those in the North Atlantic were below the detection limit of the method, i.e., below $470\ \text{pg}/\text{l}$. It is believed that these compounds were formed as a result of biomethylation of inorganic cadmium.

10.3

Organocopper Compounds

Mills et al. [20] carried out reversed-phase liquid chromatographic studies of dissolved organic matter and copper–organic complexes isolated from estuarine waters.

10.4 Organolead Compounds

If we look at the intercomparison studies that have been made on the measurement of lead in seawater [21], two points become obvious: first, that almost no one can measure lead accurately in seawater; and second, that there is much less lead present than anyone had estimated. With so little lead present in any form, identification of the organic moiety of an organolead compound becomes a major problem.

We are aided in this by our knowledge of the form in which the major anthropogenic addition is put into the system, i.e., as the tetraethyl lead additive in gasoline. Methods have been developed for the analysis of tetraalkyl lead compounds, both the original compound and those resulting from biological conversions, in the air [22]. The method for atmospheric materials uses cold trapping (-80°C) on a column of UV-1, followed by separation by gas chromatography and analysis by atomic absorption. The method for biological materials uses benzene extraction in the presence of EDTA, followed by digestion to free the lead and determination by atomic absorption. While neither of these methods is specifically designed for seawater, it should be possible to adapt them to such samples.

At least one of the organolead compounds has been shown to be a normal constituent of the aqueous environment. Tetramethyl lead has been found as a product of anaerobic bacterial metabolism in lake sediments [23]. It should perhaps be sought in the air over coastal mud flats.

Bond et al. [24] examined interferences in the stripping voltammetric method determination of trimethyl lead in seawater using polarography and mercury 199 and lead 207 NMF. It was shown that Hg^{II} reacts with $((\text{CH}_3)_2\text{Pb})^+$ in seawater. Consequently, anodic stripping voltammetric methods for determining $((\text{CH}_3)_3\text{Pb})^{2+}$ and inorganic Pb^{II} may be unreliable.

10.5 Organomercury Compounds

Methylmercury in the marine environment may originate from industrial discharges or be synthesised by natural methylation processes. Fish do not themselves methylate inorganic mercury [62, 64], but can accumulate methyl mercury from sea water [63]. Methylmercury has been detected in sea water only from Minamata Bay, Japan, an area with a history of gross mercury pollution from industrial discharge. It has been found in some sediments but at very low concentrations, mainly from areas of known mercury pollution. It represents usually less than 1% of the total mercury in the sediment, and frequently less than 0.1% [65–67]. Microorganisms within the sediments are considered to be responsible for the methylation [65, 68], and it has been suggested that methylmercury may be released by the sediments to the sea water, either in

dissolved form or attached to particulate material, and thereafter rapidly taken up by organisms [68–70].

The interest in mercury contamination, and particularly in the organic mercury compounds, is a direct reflection of the toxicity of these compounds to man. Some idea of the proliferation of work can be derived from the reviews of Krenkel [25], Robinson and Scott [26] (460 references), and Uthe and Armstrong [27] (283 references).

All forms of mercury are potentially harmful to biota, but monomethyl and dimethyl mercury are particularly neurotoxic. The lipophilic nature of the latter compounds allows them to be concentrated in higher trophic levels and the effects of this biomagnification can be catastrophic [28]. Certain species of microorganisms in contact with inorganic mercury produce methyl mercury compounds [29]. Environmental factors influence the net amount of methylmercury in an ecosystem by shifting the equilibrium of the opposing methylation and demethylation processes. Methylation is the result of mercuric ion (Hg^{2+}) interference with biochemical C-I transfer reactions [30]. Demethylation is brought about by nonspecific hydrolytic and reductive enzyme processes [31–33]. The biotic and abiotic influences that govern the rates at which these processes occur are not completely understood.

Although much of the early work on the cycling of mercury pollutants has been performed in fresh-water environments, estuaries are also subject to anthropogenic mercury pollution [34]. A strong negative correlation exists between the salinity of anaerobic sediments and their ability to form methyl mercury from Hg^{2+} . As an explanation for this negative correlation the theory was advanced that sulfide, derived by microbial reduction of sea salt sulfate, interferes with Hg^{2+} methylation by forming mercuric sulfide, which is not readily methylated [35–38]. There are several reports in the literature concerning the methylation of Hg^{2+} by methylcobalamin [30, 39, 40].

Loss of Mercury on Storage

Mercury, more than most metals, is subject to loss on storage. Methylmercury and some of the other organomercury compounds are quite volatile and easily lost from apparently sealed bottles. The problems of storage have been reviewed by Mahan and Mahan [41] and by Olson [42]. Olsen felt that the greatest losses occurred from the inorganic pool while Mahan and Mahan were more concerned with loss from samples with a high organic content. There have also been problems associated with the kinds of bottles used for storage [43].

Stoeppler and Matthes [44] have made a detailed study of the storage behaviour of methylmercury and mercuric chloride in seawater. They recommended that samples spiked with inorganic and/or methylmercury chloride be stored in carefully cleaned glass containers acidified with hydrochloric acid to pH 2.5. Brown glass bottles were preferred. Storage of methylmercury chloride should not exceed 10 days.

From the experience of the workers in this field, it would seem that the best method of handling seawater samples when analysing the mercury is, if possible, to make the analyses on shipboard as soon after collection as possible.

May et al. [45] used radiochemical studies to ascertain the behaviour of methylmercury chloride and mercuric chloride in seawater under different storage conditions. The application of ^{203}Hg unambiguously revealed that the loss of mercury observed upon storage of unacidified seawater samples in polyethylene bottles was due to adsorption and to the diffusion of metallic Hg (Hg^0) through the container wall.

For the chemical speciation of mercury compounds the storage time and the kind of storage are of paramount importance. After a three-day storage in brown glass bottles 47% of $^{203}\text{HgCl}_2$ added to the seawater became reduced to Hg^0 , but a complete reduction of Hg^{II} in the samples was not achievable. The Hg^{II} species not reduced by stannous chloride may be to a distinct extent iodides and sulfides. Within 35 days of storage $\text{CH}_3^{203}\text{HgCl}$ decomposed into Hg^0 and Hg^{II} ; 35% could be identified as Hg^0 and 27% as reactive mercury. Strong solar radiation does not influence the transformation of $^{203}\text{Hg}^{\text{II}}$ into Hg^0 , but after strong three-day solar irradiation of a sample containing $\text{CH}_3^{203}\text{HgCl}$, Hg^0 , reactive Hg^{II} , and $\text{Hg}(\text{CH}_3)_2$ could be observed. Thus cooling and darkness during storage are important prerequisites for the subsequent differentiation of mercury species. Experiments with sodium borohydride as an alternative reducing agent showed in comparison with stannous chloride a quantitative reduction of all Hg^{II} species in seawater, including $\text{CH}_3^{203}\text{Hg}$ which gave a yield of nearly 80%.

Forms of Mercury

Most of the methods of analysis for mercury actually measure inorganic mercury; to measure either organic or total mercury by such methods, it is necessary to decompose any organic mercury compounds present. This decomposition can be effected by ultraviolet irradiation of the samples. Systems of this sort have been described [46–48]. Since as much as 50% of the mercury may be present in organic form [46] the differentiation between inorganic and organic mercury can be of considerable importance.

Various workers have reported on the levels of total mercury in seawater. Generally, the levels are less than $0.2 \mu\text{g/l}$ with the exception of some parts of the Mediterranean where additional contributions due to man-made pollution are found [49–52].

Fitzgerald [53] used a cold trap to concentrate mercury from large volumes of seawater. Using this technique, he could achieve a detection limit of 0.2 ng Hg , and a coefficient of variation of 15% at the 25 ng l^{-1} level. Most oceanic samples contained less than 10 ng l^{-1} , but coastal samples could approach 50 ng l^{-1} .

With so many variations in methodology in the literature, some sort of standardisation of analytical methods is necessary. One study of standardisation

was produced by Krenkel et al. [54]. They produced a simplified extraction and clean-up procedure and recommended gas chromatography as the method of measurement.

Atomic absorption spectrometry used either by direct aspiration (to determine total mercury) or as an element-specific detector for gas chromatography (to determine organically bound mercury) are now discussed.

10.5.1

Atomic Absorption Spectrometry

Agemian and Chau [55] have described an automated method for the determination of total dissolved mercury in fresh and saline waters by ultraviolet digestion and cold vapour atomic absorption spectroscopy. A flow-through ultraviolet digester is used to carry out photo-oxidation in the automated cold vapour atomic absorption spectrometric system. This removes the chloride interference. Work was carried out to check the ability of the technique to degrade seven particular organomercury compounds. The precision of the method at levels of 0.07 $\mu\text{g/l}$, 0.28 $\mu\text{g/l}$, and 0.55 $\mu\text{g/l}$ Hg was $\pm 6.0\%$, $\pm 3.8\%$, and $\pm 1.00\%$, respectively. The detection limit of the system is 0.02 $\mu\text{g/l}$.

Depending on the particular organomercury compound, recoveries were between 95 and 102%.

Jenne and Avotins [56] have pointed out the requirement for a strong oxidising agent together with a strong acid for the preservation of low levels of mercury. Both potassium permanganate and dichromate have been used as the oxidants. The former is inadequate for samples with high chloride levels since it would be readily consumed by chloride. Carron and Agemian [57] showed that 1% sulfuric acid containing 0.05% potassium dichromate makes a very effective preservative for sub-ppb levels of mercury in water for extended periods of time, especially when coupled with glass as the container. Agemian and Chau [55] preserved samples by adding 1 ml concentrated sulfuric acid and 1 ml of 5% potassium dichromate in glass containers at the start of the dilutions or sampling.

The system has a detection limit of 0.02 $\mu\text{g/l}$ and is linear up to about 5 $\mu\text{g/l}$. A rate of 30 samples per hour was found to be the practical limit for the system.

Workers at the Department of the Environment UK have described a method for the determination of organic and inorganic mercury in seawater [58]. This method is suitable for determining dissolved inorganic mercury, and those organomercury compounds that form dithizonates, in saline sea and estuary water. In this method inorganic mercury is extracted from the acidified saline water as its dithizonate into carbon tetrachloride, but not all these compounds form dithizonates, and those that do not may not be determined by this method. In general, organomercury compounds of the type RHg-X , in which X is a simple anion, form dithizonates, whereas the type $\text{R}_1\text{-Hg-R}_2$ does not. Mono-methylmercury ion is extracted, although it only appears

to have a transient existence in aerobic saline water. The dithizonates are decomposed by the addition of hydrochloric acid and sodium nitrite, and the mercury or organomercury compound returned to the aqueous phase. Some organomercury compounds may not be completely re-extracted into the aqueous phase. The mercury in this aqueous phase is determined by the stannous chloride reduction-atomic absorption spectroscopic technique.

Down to 4 ng/l organomercury can be determined by this method with a standard deviation of 1.3 ng/l at the zero mercury level.

Fitzgerald and Lyons [46] have described flameless atomic absorption methods for determining organic mercury compounds in coastal and seawaters, using ultraviolet light in the presence of nitric acid to decompose the organomercury compounds. In this method two sets of 100 ml samples of water are collected in glass bottles and then adjusted to pH 1.0 with nitric acid. One set of samples is analysed directly to give inorganically bound mercury, the other set is photo-oxidised by means of ultraviolet radiation for the destruction of organic material and then analysed to give total mercury. The element is determined by a flameless atomic absorption technique, after having been collected on a column of 1.5% of OV-17 and 1.95% of QF1 on Chromosorb WHP (80–100 mesh). The precision of analysis is 15%. It was found that up to about 50% of the mercury present in river and coastal waters is organically bound or associated with organic matter.

Millward and Bihan [59] studied the effect of humic material on the determination of mercury by flameless atomic absorption spectrometry. In both fresh and seawater, association between inorganic and organic entities takes place within 90 min at pH values of 7 or above, and the organically bound mercury was not detected by an analytical method designed for inorganic mercury. The amount of detectable mercury was related to the amount of humic material added to the solutions. However, total mercury could be measured after exposure to ultraviolet radiation under strongly acid conditions.

Yamamoto et al. [60] determined picogram quantities of methyl mercury and total mercury in seawater by gold amalgamation and atomic absorption spectrometry. Methyl mercury was extracted with benzene and concentrated by a succession of three partitions between benzene and cysteine solution. Total mercury was extracted by wet combustion of the sample with sulfuric acid and potassium permanganate. The proportion of methyl mercury to total mercury in the coastal seawater sampled was around 1%.

Graphite furnace atomic absorption spectrophotometry has been used for the determination down to 5 ng/l inorganic and organic mercury in seawater [61]. The method used a preliminary preconcentration of mercury using the ammonium pyrrolidine dithiocarbamate-chloroform system. A recovery of 85–86% of mercury was reproducibly obtained in the first chloroform extract and consequently it was possible to calibrate the method on this basis. A standard deviation of 2.6% was obtained on a seawater sample containing 529 ng/l mercury.

The relative standard deviation of ten repeated determinations of 500 ml distilled water containing 10 ng mercury (II) chloride was 17.4%.

10.5.2

Gas Chromatography

Davis et al. [71] set out to determine the concentrations of methylmercury in sea water samples much less polluted than at Minamata Bay, namely at the Firth of Forth, Scotland. They described a tentative bioassay method for determining methylmercury at the 0.06 ng/l level. Mussels from a clean environment were suspended in cages at several locations in the Firth of Forth. A small number were removed periodically, homogenised, and analysed for methylmercury by solvent extraction–gas chromatography, as described by Westoo [72, 73]. The rate of accumulation of methylmercury was determined, and by dividing this by mussel filtration rate, the total concentration of methylmercury in the sea water was calculated. The methylmercury concentration in caged mussels increased from low levels (less than 0.01 $\mu\text{g/g}$) to 0.06–0.08 $\mu\text{g/g}$ in 150 days, giving a mean uptake rate of 0.4 ng/g/d, i.e., a 10 g mussel accumulated 4 ng/d. The average percentage of total mercury in the form of methylmercury increased from less than 10% after 20 days to 33% after 150 days. Davies et al. [71] calculated the total methylmercury concentration in the sea water as 0.06 $\mu\text{g/l}$, i.e., 0.1–0.3% of the total mercury concentration as opposed to less than 5–32 ng/l methyl mercury found in Minamata Bay, Japan. These workers point out that a potentially valuable consequence of this type of bioassay is that it may be possible to obtain estimates of the relative abundance of methyl mercury at different sites by the exposure of “standardised” mussels as used in their experiment, in cages for controlled periods of time, and by comparison of the resultant accumulations of methylmercury.

The high sensitivity and selectivity of some gas chromatographic detectors are used to advantage in the measurement of organic mercury compounds. In the simplest approach, methyl mercury is extracted from seawater and converted to the iodide for electron capture gas chromatography [74].

Ealy [75] also used conversion to alkyl mercury iodides for the gas chromatographic determination of organomercury compounds in benzene extracts of water. The iodides were then determined by gas chromatograph of the benzene extract on a glass column packed with 5% of cyclohexane-succinate on Anakron ABS (70–80 mesh) and operated at 200 °C with nitrogen (56 ml min⁻¹) as carrier gas and electron capture detection. Good separation of chromatographic peaks was obtained for the mercury compounds as either chlorides, bromides, or iodides. The extraction recoveries were monitored by the use of alkylmercury compounds labelled with ²⁰³Hg.

An increase in specificity, permitting a lesser concern with clean-up procedures, can be gained by using a microwave emission spectrometer as the

gas chromatography detector [76]. A similar method, using extraction of methylmercury compounds into benzene, followed by back-extraction into L-cysteine, conversion to the chloride, back-extraction into benzene, and analysis by electron capture gas chromatography, was devised by Chau and Saitoh [77].

The importance of selectivity and sensitivity in the detection system can be seen by examining the concentration and clean-up procedures used by Hobo et al. [78]. They used foam separation, with the addition of a surface-active compound, to collect the organic mercury compounds, followed by extraction of the foam with an organic solvent and removal of interfering heavy metals by column chromatography. Cappon and Smith [79] used a double extraction, in which the organic mercury compounds were first removed and the remaining inorganic mercury was converted to methylmercury by reaction with tetramethyltin, and then extracted. The two organic fractions were then cleaned up by standard procedures and determined by gas chromatography.

Compeau and Bartha [80] have discussed the abiotic methylation of mercuric ion and mercuric ion sea salt anion complexes to methylmercury by methylcobalamin in seawater and saline sediments under aerobic and anaerobic conditions.

The reaction of 30 $\mu\text{mol/l}$ methylcobalamin and 60 nmol/l mercuric chloride to produce methyl mercury was measured by two different methods. A spectrophotometer was used to measure changes in absorbance at 351 nm and 380 nm, respectively. These are changes characteristic of the transition of methylcobalamin to aquocobalamin [81].

Methyl mercury formed in the reaction was also measured gas chromatographically in benzene extracts of the aqueous phase [82].

An increase in absorbance at 351 nm and a concomitant decrease in absorbance at 380 nm in the ultraviolet visible spectrum of methylcobalamin during the abiotic transfer of the methyl group to Hg^{2+} are characteristic for the loss of the methyl group and formation of aquocobalamin. In experiments monitored by both analytical techniques, gas chromatographic measurements of methylmercury formation were in good agreement with the spectrophotometric measurement of aquocobalamin formation from methylcobalamin at 351 nm. Aerobic versus anaerobic reaction conditions had no measurable effect on either the methyl transfer rates, the stability of the reactants, or on the reaction products.

A number of analytical methods for the separation of organic mercury compounds use an initial extraction of the organic materials with an organic solvent. Klisenko and Shmigidina [83] then converted both the inorganic mercury held in the aqueous fraction and the organic mercury in the chloroform extract to dithizonate, separated the components on chromatographic columns, and determined the concentration of the various fractions by comparison with reference standards. This method is semi-quantitative at best.

10.5.3

Miscellaneous

Differentiation of inorganic and organic mercury can be achieved in a number of different ways, many of which depend upon the reduction and vapourisation of the inorganic mercury, followed by reduction [84] or oxidation [85,86] of the organic mercury compounds, and a final measurement by atomic absorption or mass spectrometry. Similar methods of separation of the inorganic and organic components are used in the pretreatment of samples where the final analysis for mercury is to be made by neutron activation analysis [87,88].

Sipos et al. [89] used subtractive differential pulse voltammetry at a twin gold electrode to determine total mercury levels in seawater samples taken from the North Sea.

Ke and Thibert [90] have described a kinetic microdetermination of down to 0.05 $\mu\text{g/l}$ of inorganic and organic mercury in river water and seawater. Mercury is determined by use of the iodide-catalysed reaction between Ce^{IV} and As^{III} , which is followed spectrophotometrically at 273 nm.

Methylmercury has been preconcentrated from seawater by extraction with a solution of dithizone prior to analysis by gold foil cold vapour atomic absorption spectrometry [126].

Hammerschmidt and Fitzgerald [127] have studied the formation of artifact methylmercury during extraction from a sediment reference material.

10.6

Organothallium Compounds

Schedlbauer and Heumann [91] have described a sensitive analytical method for the determination of dimethyl thallium (Me_2Tl^+) in environmental samples by positive thermal ionisation isotope dilution mass spectrometry (PTI-IDMS). For the necessary low detection limit and for species selective determination, PTI-IDMS was connected with species-unspecific enrichment of thallium from ocean water samples by a strongly basic anion exchanger and a species-specific extraction step, respectively. For isotope dilution, a ^{203}Tl -enriched Me_2Tl^+ spike solution was synthesised and characterised with respect to its isotopic composition and concentration. The spike solution was stable for at least 30 months under dark storage conditions at $\text{pH} = 2$ and 4°C . The detection limit of the developed method is 0.4 ng/l for 500 ml ocean water samples, and the species selectivity of Me_2Tl^+ , compared with that of inorganic thallium, is > 500 . In different surface water samples of the Atlantic Ocean from 56°N to 64°S and in one depth profile down to 4000 m, Me_2Tl^+ concentrations in the range < 0.4 to 3.2 ng/l were determined. This was the first time that dimethyl thallium had been detected in environmental samples. Positive detection of the organothallium compound was found in about 20% of all samples analyzed. By also analyzing the total thallium content with PTI-IDMS it was found that

in these cases 3–48% of thallium exists in the methylated form. From its occurrence in the remote areas of the South Atlantic, from positive correlation with the bioactivity in the corresponding ocean water, and from the fact that Me_2Tl^+ is not known as an anthropogenic substance, it follows that a biogenic origin must be assumed.

10.7 Organotin Compounds

Several investigators have recently reported ng/l– $\mu\text{g/l}$ concentrations of organotin compounds in both fresh water and marine samples. Inorganic tin, methyltins, and butyltins have been detected in marine and fresh water environmental samples [92–95]. The presence of inorganic tin, butyltin, and methyltin species has been reported in Canadian lakes, rivers, and harbours [96, 97]. Both organotins and inorganic tin were reported to be highly concentrated by factors of up to 10^4 in the surface microlayer relative to subsurface water [96, 97]. Inorganic tin, mono-, di-, and trimethyltins have been detected at ng/l levels in saline, estuarine, and fresh water samples [94, 98]. Methylation of tin compounds by biotic as well as abiotic processes has been proposed [99, 100].

Possible anthropogenic sources of organotins have recently been suggested. Both polyvinylchloride (PVC) and chlorinated polyvinylchloride (CPVC) have been shown to leach methyltin and dibutyltin compounds, respectively, into the environment [101]. Monobutyltin has been measured in marine sediments collected in areas associated with boating and shipping. Butyltin was not detected in areas free of exposure to maritime activity [102]. The use of organotin antifouling coatings in particular has stimulated interest in their environmental impact.

The techniques used for the investigation of organotin compounds in seawater are atomic absorption spectrometry, gas chromatography, or gas chromatography using AAS as detector.

10.7.1 Atomic Absorption Spectrometry

Hodge et al. [92] have described an atomic absorption spectroscopic method for the determination of butyltin chlorides and inorganic tin in natural waters, coastal sediments, and macro algae in amounts down to 0.4 ng.

Valkirs et al. [103] determined the range of butyltin compounds in samples collected within San Diego Bay (CA, USA). Results suggested that in certain areas of the bay the use of tin-containing antifouling paints on ships was increasing. Water extracted with methylisobutyl ketone and analysed by GFA-AS consistently yielded higher tin concentrations than the same samples analysed

by a hydride reduction/flame atomic absorption method [92, 98], suggesting a non-hydride reducible tin fraction was present. Gas chromatography–mass spectrometry confirmed the presence of tributyltin in an environmental marine water sample following derivatisation to the hydride species.

Surface and bottom water samples were collected in 500 ml, 1, or 4 litre polycarbonate bottles. Polycarbonate bottles have been shown to retain 97% of an initial spike of bis(tri-*n*-butyltin) oxide in seawater at a concentration of 0.5 mg/l over a weeklong period [104]. Samples were analysed immediately after collection and transported to the laboratory, or were stored frozen at -20°C and analysed at a later date. Frozen storage has been shown to be effective in preserving sample stability with respect to monobutyltin, dibutyltin, and tributyltin concentrations for a period of at least 100 days.

An estimate of the accuracy of both analytical methods was performed on bis(tri-*n*-butyltin) oxide and tri-*n*-butyltin chloride solutions (8.9–35.6 $\mu\text{g/l}$) prepared in filtered (0.45 μm) near-shore seawater free of detectable organotins. Average mean recoveries of 92.8% by both methods were determined for tributyltin standard solutions. Low ng/l levels of mono-, di-, and tributyltin were found in samples taken from San Diego Bay.

Valkirs et al. [105] have conducted an interlaboratory comparison or determinations of di- and tributyltin species in marine and estuarine waters using two methods, namely hydride generation with atomic absorption detection and gas chromatography with flame photometric detection. Good agreement was obtained between the results of the two methods. Studies on the effect of storing frozen samples prior to analysis showed that samples could be stored in polycarbonate containers at -20°C for 2–3 months without significant loss of tributyltin.

Burns et al. [106] used electrothermal AAS to determine inorganic and butyltin in seawater. The butyltin is extracted into toluene and the inorganic tin extracted as its Sn(IV) 8-hydroxyquinoline chelate into chloroform. The detection limit was 0.7 ng of tin.

The separation of mono-, di-, and tributyltin species in seawater by isocratic ion exchange liquid chromatography coupled to hydride generation AAS has been reported by Schulze and Lehmann [107]. Reported detection limits are 31, 40, and 27 mol/l, respectively.

10.7.2

Gas Chromatography

Studies by Braman and Tompkins [98] have shown that nonvolatile methyltin species $\text{Me}_n\text{Sn}_{\text{aq}}^{(4-n)+}$ ($n = 1-3$), are ubiquitous at ng/l concentrations in natural waters including both marine and fresh water sources. Their work, however, failed to establish whether tetramethyltin was present in natural waters because of the inability of the methods used to trap this compound effectively during the

combined preconcentration purge and reductive derivatisation steps employed to generate volatile organotin hydrides necessary for tin specific detection.

Tin compounds are converted to the corresponding volatile hydride (SnH_4 , CH_3SnH_3 , $(\text{CH}_3)_2\text{SnH}_2$, and $(\text{CH}_3)_3\text{SnH}$) by reaction with sodium borohydride at pH 6.5 followed by separation of the hydrides and then atomic absorption spectroscopy using a hydrogen-rich hydrogen-air flame emission type detector (Sn-H band).

The technique described has a detection limit of 0.01 ng as tin, and hence parts per trillion of organotin species can be determined in water samples.

Braman and Tompkins [98] found that stannane (SnH_4) and methylstannanes (CH_3SnH_3 , $(\text{CH}_3)_2\text{SnH}_2$ and $(\text{CH}_3)_3\text{SnH}$) could be separated very well on a column comprising silicone oil OV-3 (20% w/w) supported on Chromosorb W. A typical separation achieved on a water sample is shown in Fig. 10.2.

The generation and recovery of stannane, methyl-, dimethyl-, and trimethylstannane were studied in seawater. Average tin recoveries for the six samples analysed, to which were added 0.4–1.6 μg methyltin compounds and 3 ng inorganic tin, ranged from 96 to 109%. Reanalysis of analysed samples shows that all methyltin and inorganic tin is removed in one analysis procedure.

A number of natural waters, from in and around the area of Tampa Bay, Florida, were analysed for tin content. All samples were analysed without pretreatment. Samples that were not analysed immediately were frozen until analysis was possible. Polyethylene bottles, 500 ml volume, were used for sample acquisition and storage. The results of the analyses appear in Table 10.1. The average total tin content of fresh, saline, and estuarine waters are 9.1, 4.2, and 12 ng/l, respectively. Approximately 17–60% of the total tin present was found to be in the methylated forms. The saline waters appear to have the highest percentage of methylated tin compounds; 60% of the total tin present

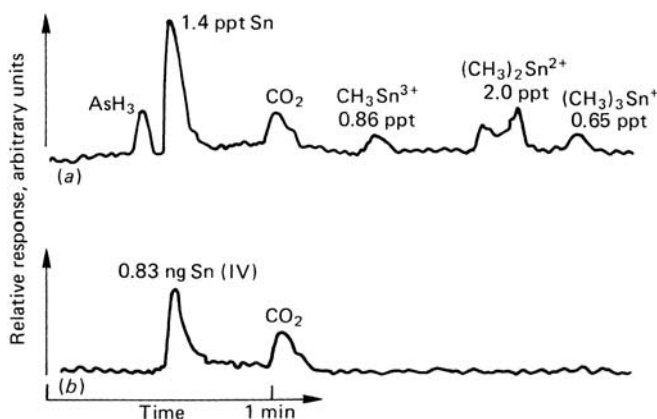

Figure 10.2. Environmental sample analysis of organotin compounds. a Environmental sample, Tampa Bay. b Typical blank. Source: [98]

Table 10.1. Analysis of saline and estuarine water samples. Data are average of duplicates (given in ng/l; results in parentheses are percentages of total tin) [98]

Sample	Tin(IV)	Methyl tin	Dimethyl tin	Trimethyl tin	Total tin
Gulf of Mexico, Sarasota	62 (73)	15 (18)	7.0 (8.3)	0.98 (1.2)	85
Gulf of Mexico, Fort De Soto	2.2 (6.0)	ND	0.74 (2.0)	0.71 (20)	3.6
Gulf of Mexico, St. Petersburg	4.5 (54)	0.62 (7.4)	3.2 (39)	ND	8.3
Old Tampa Bay, Oldsmar	0.3 (9.7)	0.86 (33)	0.88 (34)	0.61 (24)	2.6

was found to be in the methylated forms, and the dimethyltin form contributes approximately half of this value.

The above procedure, although valuable in itself, is incomplete in that any monobutyltin species present escape detection. Excellent recoveries of monobutyltin species are achieved with tropolone.

Meinima et al. [108] studied the effect of combinations of various solvents with 0.05% tropolone on the recoveries of mono-, di-, and tributyltin species either individually or simultaneously present in aqueous solutions. The results obtained by gas chromatography–mass spectrometry after methylation show that Bu_3Sn and Bu_2Sn recoveries appear to be almost quantitative both for neutral and from hydrobromic acid-acidified aqueous solutions. Butyltin recovery appears to be influenced by the presence of hydrobromic acid in that, in general, recovery rates are higher from solutions acidified with hydrobromic acid than from non-acidified solutions. Bu_3Sn and Bu_2Sn recoveries remain fairly constant with ageing of an aqueous solution of these species over a period of several weeks. Butyltin recoveries, however, do decrease with time to a notable extent (20–40%), most likely as a result of adsorption/deposition of Bu_1Sn species to the glass wall of the vessel. Addition of hydrobromic acid obviously affects the desorption of these species, as recovery of Bu_1Sn species increases to almost the same values as obtained from hydrobromic acid-acidified freshly prepared aqueous solutions of species.

Jackson et al. [109] devised trace speciation methods capable of ensuring detection of tin species, along with appropriate preconcentration and derivatisation without loss, decomposition, or alteration of their basic molecular features.

They describe the development of a system employing a Tenax GC filled purge and trap sampler, which collects and concentrates volatile organotins from water samples (and species volatilised by hydrodisation with sodium borohydride), coupled automatically to a gas chromatograph equipped with

a commercial flame photometric detector modified for tin-specific detection [110–112].

The system was applied to the analysis of a series of water samples obtained from the Chesapeake Bay at both industrially polluted and relatively pristine sites.

The volatile species were determined by the purge and trap gas chromatographic flame photometric detector method without the sodium borohydride reduction step. Non-volatile species were volatilised, trapped, and detected with the volatile species present in the samples. Generally no changes in the concentration of the volatile species were observed with the hydride reduction step. An increase in the amount detected, as with Me_2SnH_2 and BuSnH_3 , indicated that the solvated cations were also present in the water samples along with the respective free stannane. The prevailing gas chromatographic peak at 1.75 ± 0.04 min has not been completely resolved or identified. The retention time is within the range of both dimethyl sulfide (Me_2S) and Me_2SnH_2 . Dimethyl sulfide is known to be a microbial metabolite present in environmental water; therefore, this is a possible interference.

Brinckmann and co-workers [113] used a gas chromatographic method with or without hydride derivatisation for determining volatile organotin compounds (e.g., tetramethyltin) in seawater. For nonvolatile organotin compounds a direct liquid chromatographic method was used. This system employs a “Tenax GC” polymeric sorbent in an automatic purge and trap (P/T) sampler coupled to a conventional glass column gas chromatograph equipped with a flame photometric detector. Flame conditions in the FPD were tuned to permit maximum response to SnH emission in an H-rich plasma, as detected through narrow bandpass interference filters (610 ± 5 nm). Two modes of analysis were used:

- (1) Volatile stannanes were trapped directly from sparged 10–50 ml water samples with no pretreatment.
- (2) Volatilised tin species were trapped from the same or replicate water samples following rapid injection of aqueous, excess sodium borohydride solution directly into the P/T sparging vessel immediately prior to beginning the P/T cycle.

10.7.3

Hydride Generation Gas Chromatography– Microwave Induced Atomic Emission Spectrometry (HGGC–MIAES)

A recent method [114] for the speciation of organotin compounds in seawater combines solid-phase extraction, online HG, and GC with MIAE. This method enjoys a 0.5 pg detection limit for tin.

10.7.4

Thermal Desorption-Gas Chromatography–Inductively Coupled Plasma Mass Spectrometry (TDGC–ICPMS)

Vercauteren et al. [115] have investigated the extraction and preconcentration capabilities of a new extraction technique in which stir bar sorptive extraction was combined with the separation power of capillary gas chromatography and the low limits of detection of ICPMS for the determination of the organotin compounds tributyltin and triphenyltin in aqueous standard solutions, harbour water, and mussels after digestion with tetramethylammonium hydroxide. Throughout, tripropyltin for tributyltin and tricyclohexyltin for triphenyltin were used as internal standards to correct for variations in the derivatisation and extraction efficiency. Calibration was accomplished by means of single standard addition. Derivatisation to transform the trisubstituted compounds into sufficiently volatile compounds was carried out with sodium tetraethylborate. The compounds were extracted from their aqueous matrix using a stir bar of 1 cm length, coated with 55 μl of poly(dimethylsiloxane). After 15 min of extraction, the stir bar was desorbed in a thermal desorption unit at 290 °C for 15 min, during which the compounds were cold-trapped on a precolumn at –40 °C. Flash heating was used to rapidly transfer the compounds to the gas chromatograph where they were separated on a capillary column with a poly(dimethylsiloxane) coating. After separation, the compounds were transported to the ICP by means of a homemade heated (270 °C) transfer line. Monitoring of the $^{120}\text{Sn}^+$ signal by ICPMS during the run of the gas chromatograph provided extremely lower limits of detection in water: 0.1 pg/l (procedure) and 10 fg/l (instrumental) and a repeatability of 12% RSD ($n = 10$). In harbour water, concentrations were found of 200 pg/l for tributyltin. The accuracy of the method was checked by the determination for triphenyltin in CRM 477 (mussel tissue) and comparison of the results to that of an analysis of the same material with a classical liquid–liquid extraction with isooctane.

Encinar et al. [128] used a spike containing ^{119}Sn enriched mono-, di-, and tributyltin to determine butyltin compounds in seawater GC–ICPMS. Reverse spiking was used to assess species transformation during derivatisation.

To determine organotin compounds in amounts down to 1–5 ng/l, McAvoy et al. [129] ethylated the seawater, isolated organotin solid-phase micro extraction and determined it by micro capillary GCMS.

Pocurull et al. [130] used the online solid-phase extraction GCMS preconcentration method to determine organotin antifouling compounds in seawater; 10 ng/l detection limits were achieved using a 10 ml sample.

Ferrer and Barcelo [131] used online solid-phase–liquid chromatography mass spectrometry for the simultaneous determination of organotin antifouling herbicides in marine water. The solid-phase extraction was carried out on polymeric cartridges after percolation of 100 ml of the seawater sample, and

showed recoveries of 96–111% of the antifouling compound. Detection limits were about 5 ng/l.

Tao et al. [132] achieved a 0.01 pg/l detection limit for organotin species in seawater using GC–ICPMS. This method involved derivitisation using a Grignard reagent, sodium tetraethylborate preconcentration by extraction into hexane, a programmed temperature vaporisation, and the operation of a shield torch at normal conditions. The use of the programmed temperature vaporisation enabled the injection of large sample volumes, up to 100 μ l without loss of analyte.

10.7.5

High-Performance Liquid Chromatography

Ebdon and Alonso [116] have determined tributyltin ions in estuarine waters by high-performance liquid chromatography and fluorometric detection using morin as a micellar solution. Tributyltin ions were quantitatively retained from 100–500 mL of sample on a 4 cm-long ODS column. After washing off the salts with 20 ml of distilled water the ODS column was back-flushed with methanol-water (80 + 20) containing 0.15 M ammonium acetate, on a 25 cm-long Partisil SCX analytical column. The eluant from the column (1 ml min⁻¹) was mixed with fluorometric reagent (acetic acid, (0.01 M); morin (0.0025% m/v); Triton X-100, (0.7% m/v 2.5 ml/min)) for detection at 524 nm with excitation at 408 nm. The detection limit (2σ) is 16 ng of tributyltin (as Sn).

10.7.6

Miscellaneous

Smith [117] discussed the determination of tin in water. In the determination of low concentrations of the order of 40 ng of trialkyltin chlorides in sea water it has been observed that these compounds are very volatile and are easily lost upon evaporation with acid. Quantitative recovery of tin is, however, obtained in the absence of chloride ion during evaporation with acid. Preliminary removal of chlorides from sea water by passage down a column of IRA 400 resin before digestion with acid completely overcame loss of tin on subsequent evaporation, with acid giving a tin recovery of 90%.

Duhamel et al. [118] investigated the behaviour of this (tributyltin) oxide and tributyltin chloride in saline water. The effects of salinity, pH, light, and oxygen were investigated. Debutylation due to the formation of insoluble compounds occurred under saline conditions.

Kenis and Zirino [119] determined tri-*n*-butyltin oxide directly in seawater at microgram per litre levels at a hanging drop mercury electrode, and at a mercury film rotating-disk glassy electrode by differential pulse anodic-stripping voltammetry. The hanging drop mercury electrode responded to tri-*n*-butyltin oxide additions in sea water purged either with nitrogen (pH 8.2)

or carbon dioxide (pH 4.8) with two distinct stripping peaks. The mercury film rotating-disk glassy electrode produced stripping peaks due to tri-*n*-butyltin oxide at pH 8.2, and no response at pH 4.8. Peak potentials and peak heights varied depending upon the history of the water samples, suggesting an influence by dissolved basic materials. The limit of detection for tri-*n*-butyltin oxide in sea water on the hanging drop electrode was 5 ng/l. The hanging drop electrode responded to additions of inorganic tin in sea water at pH 4.8 and 8.2, whereas the rotating-disk electrode did not respond at either pH.

Luskima and Syavtsillo [120] have described a spectrophotometric procedure utilising phenylfluorone for the determination of organotin compounds in water.

A method for the determination of organotin compounds by anodic stripping polarography has been published [121]. It has yet to be applied to seawater. Since the sensitivity permits the measurement of 0.01 ppm of the tin compounds, it is likely to be not quite sensitive enough for seawater and would require a preconcentration step.

Laughlin et al. [122] analysed chloroform extracts of tributyltin dissolved in seawater using nuclear magnetic resonance spectroscopy. It was shown that an equilibrium mixture occurs which contains tributyltin chloride, tributyl tin hydroxide, the aquo complex, and a tributyltin carbonate species. Fluorometry has been used to determine triphenyltin compounds in seawater [123]. Triphenyltin compounds in water at concentrations of 0.004–2 pmg/l are readily extracted into toluene and can be determined by spectrofluorometric measurements of the triphenyltin-3-hydroxyflavone complex.

Tri-, di-, and monobutyl, and di- and monoethyltin compounds, did not fluoresce under the conditions used for the determination of triphenyltin. However, trimethyltin compounds react in a similar manner with 3-hydroxyflavone, and although the emission maximum is at approximately 510 nm, this is not sufficiently different from the emission maximum of triphenyltin compounds (approximately 495 nm) for these compounds to be determined in the presence of one another.

Spiking recoveries by the above procedure carried out on standard solutions of triphenyltin chloride in various types of water ranged from 74% at the 4 µg/l tin level (relative sd 8.9%) to 93.6% at the 2 mg/l tin level (relative sd 4.2%).

Organotin compounds have preconcentrated on cation exchange resins [124] and XAD-2 resin [125] (See Table 9.3).

References

1. Braman RS, Foreback GC (1973) *Science* **182**:1247
2. Woolson EA (1975) Arsenical pesticides. ACS symposium series no. 7. American Chemical Society, Washington, DC
3. Penrose WR (1974) *Crit Rev Environ Contr* **4**:465
4. Andraea MO (1977) *Anal Chem* **49**:820

5. Braman RS, Johnson DL, Foreback CC, Ammons JM, Bricker JL (1977) *Anal Chem* **49**:621
6. Howard AG, Arbab-Zavar MH (1981) *Analyst* **106**:213
7. Arbab-Zavar MH, Howard AG (1980) *Analyst* **105**:744
8. Hinnners TA (1980) *Analyst* **105**:751
9. Pierce FD, Brown HR (1977) *Anal Chem* **49**:1417
10. Talmi Y, Bostick DT (1975) *Anal Chem* **47**:2145
11. Edmonds JS, Francesconi KA (1976) *Anal Chem* **48**:2019
12. Johnson DL, Braman RS (1975) *Deep-Sea Res* **22**:503
13. Braman RS, Johnson DL, Foreback CC, Ammons JM, Bricker JL (1977) *Anal Chem* **49**:621
14. Persson J, Irgum K (1982) *Anal Chim Acta* **138**:111
15. Lundgren G, Lundwork L, Johansson G (1974) *Anal Chem* **46**:1028
16. Yamamoto M (1975) *Soil Science Society of America Proceedings* **39**:859
17. Haywood MG, Riley JP (1976) *Anal Chim Acta* **85**:219
18. De Bettencourt Am, Florencio MH, Duarte MFN, Gomes MLR, Boas LFCV (1994) *Appl Organometall Chem* **8**:43
19. Pongratz R, Heumann KG (1996) *Anal Chem* **68**:1262
20. Mills GL, McFadden E, Quinn JG (1987) *Mar Chem* **20**:313
21. Patterson C, Settle D (1976) *Mar Chem* **4**:389
22. Chau YK, Wong PTS, Saitoh H (1976) *J Chromatogr Sci* **14**:162
23. Wong PTS, Chau YK, Luxon PL (1975) *Nature* **253**:263
24. Bond AM, Bradbury JR, Hanna PJ, Howell GN, Hudson HA, Strother S, O'Connor MJ (1984) *Anal Chem* **56**:2392
25. Krenkel PA (1973) *Int Crit Rev Environ Cont* **3**:303
26. Robinson S, Scott WB (1974) A selected bibliography on mercury in the environment, with subject listing. Life science miscellaneous publication. Royal Ontario Museum, p 54
27. Uthe JF, Armstrong FAJ (1974) *Toxicol Environ Chem Rev* **2**:45
28. D'Itri PA, D'Itri PM (1978) *Environmental Management* **2**:3
29. Jensen S, Jernelov A (1969) *Nature* **753**:223
30. Wood JM (1974) *Science* **183**:1049
31. Furakawa K, Tonomura K (1971) *Agr Biol Chem* **35**:604
32. Furakawa K, Tonomura K (1972) *Agr Biol Chem* **36**:217
33. Furakawa K, Tonomura K (1972) *Agr Biol Chem* **36**:2441
34. Brinckman FE, Iverson WP (1975) In: Church T (ed) *Marine chemistry in the coastal environment*. American Chemical Society symposium 18. American Chemical Society, Washington, DC
35. Fagerstrom T, Jernelov A (1971) *Water Res* **5**:121
36. Yamada M, Tonomura K (1972) *J Ferment Tech* **50**:159
37. Yamada M, Tonomura K (1972) *J Ferment Tech* **50**:893
38. Yamada M, Tonomura K (1972) *J Ferment Tech* **50**:901
39. Bertilsson L, Neujahr HY (1971) *Biochemistry* **10**:2805
40. Imura NE, Sukegawa SK, Pan K, Nagao K, Kim JK, Kwan T, Ukita T (1971) *Science* **172**:1248
41. Mahan KI, Mahan SE (1977) *Anal Chem* **49**:662
42. Olson KR (1977) *Anal Chem* **49**:23
43. Heiden RW, Aikens DA (1977) *Anal Chem* **49**:668
44. Stoeppler M, Matthes W (1978) *Anal Chim Acta* **98**:389
45. May K, Reisinger K, Rlucht R, Stoeppler M (1980) *Sendeedenck vom Wasser* **55**:63

46. Fitzgerald WF, Lyons WB (1973) *Nature* **242**:452
47. Fimmel E, Winkler HA (1975) *Zeitung Wasser-Abwasser-Forschung* **8**:67
48. Kiemeneij AM, Kloosterboer JG (1976) *Anal Chem* **48**:575
49. Thibaud Y (1971) *Science et Peche, Bulletin Instrumental Peche Maritime* **209**:1
50. Cumont G, Viallex G, Lelievre H, Babenricht P (1972) *Revue Internationale Oceanographie Mediterranee* **26**:95
51. Renzoni A, Baldi F (1975) *Accua and Aria* 597
52. Stoeppler M, Backhaus F, Matthes W et al. (1976) *Proc. Verb. XXVth Congress and Plenary Assembly of ICSEM, Split*
53. Fitzgerald WF (1975) Mercury analyses in seawater using cold trap preconcentration and gas-phase detection. In: Gibb RP Jr (ed), *Analytical Methods in Oceanography*, American Chemical Society, Washington, DC, pp 99–109, 147
54. Krenkel PA, Burrow W, Dickinson W (1975) Standardization of methylmercury analysis. Report COM-75-10673
55. Agemian H, Chau ASY (1978) *Anal Chem* **50**:13
56. Jenne EA, Avotins P (1975) *J Environ Qual* **4**:427
57. Carron J, Agemian H (1977) *Anal Chim Acta* **92**:61
58. Department of the Environment and National Water Council (UK) (1985) Mercury in waters, effluents, soils, and sediments, etc., additional methods. Pt 22-AG ENV. HMSO, London
59. Millward GE, Bihan AI (1978) *Water Res* **12**:979
60. Yamamoto J, Kaneda Y, Hisaka Y (1983) *Int J Environ Anal Chem* **16**:1
61. Filippelli M (1984) *Analyst* **109**:515
62. Pennicichioni A, Marchetti R, Gaggino GF (1976) *J Environ Qual* **5**:451
63. Pentreath RJ (1976) *J Exp Mar Biol Ecol* **25**:51
64. Pentreath RJ (1976) *J Exp Mar Biol Ecol* **25**:103
65. Olsen BH, Cooper RC (1976) *Water Res* **10**:113
66. Andrer AW, Harris RC (1973) *Nature* **245**:256
67. Bartlett PO, Craig PJ, Morton SF (1977) *Nature* **267**:606
68. Shin E, Krenkel PA (1976) *J Water Pollut Cont Fed* **48**:473
69. Jeruelev A (1970) *Limnol Oceanogr* **15**:958
70. Langley DG (1973) *J Water Pollut Cont Fed* **49**:44
71. Davis IM, Graham WC, Pirie JM (1979) *Mar Chem* **7**:11
72. Westhoo G (1966) *Acta Chim Sci Anal* **20**:2131
73. Westhoo G, Johanssen B, Ryhage R (1978) *Acta Chem Scand* **28**:2277
74. Longbottom JE, Dressman RC, Lichtenberg JJ (1973) *J Assoc Off Anal Chem* **56**:1297
75. Ealy J, Schulz WD, Dean DA (1974) *Anal Chim Acta* **64**:235
76. Talmi U (1975) *Anal Chim Acta* **74**:107
77. Chau YK, Saitoh H (1973) *Int J Environ Anal Chem* **3**:133
78. Hobo T, Ogura T, Suzuki S, Araki S (1975) *Bunseki Kagaku* **24**:288
79. Cappon CJ, Smith JC (1977) *Anal Chem* **49**:365
80. Compeau G, Bartha R (1983) *Bull Environ Contam Toxicol* **31**:486
81. Dolphin D (1971) In: McCormick DB, Wright LD (eds) *Methods in enzymology*, vol. 18, part c. Academic Press, New York
82. Blum J, Bartha R (1980) *Bull Environ Contam Toxicol* **25**:404
83. Klisenko MA, Shmigidina AM (1974) *Gig Sahit* **1974**:64
84. Kamada T, Hayashi Y, Kumamaru T, Yamamoto Y (1973) *Bunseki Kagaku* **22**:1481
85. Baltisberger RJ, Knudson CL (1974) *Anal Chim Acta* **73**:265
86. El-Awady AA, Miller RB, Clark MJ (1976) *Anal Chem* **48**:110
87. Van der Sloot HA, Das HA (1974) *Anal Chim Acta* **73**:235

88. De Jong EG, Wiles DR (1976) *Journal of the Fisheries Research Board of Canada* **33**:1324
89. Sipos L, Nurenberg HW, Valenta P, Branica M (1980) *Anal Chim Acta* **115**:25
90. Ke PJ, Thibert RT (1973) *Mikrochim Acta* **3**:417
91. Schedlbauer OF, Heumann KG (1999) *Anal Chem* **71**:5459
92. Hodge VF, Seidel SL, Goldberg ED (1979) *Anal Chem* **51**:1256
93. Waldoek MJ, Miller D (1983) ICES paper CM 1983 E:12 (mimeograph). International Council for the Exploration of the Sea, Copenhagen
94. Tugrul S, Balkas TL, Goldberg ED (1983) *Mar Pollut Bull* **14**:297
95. Müller MD (1984) *Fresen Z Anal Chem* **317**:32
96. Maguire RJ, Chau YK, Bengert GA, Hale EJ, Wong PTS, Kramar O (1982) *Environ Sci Technol* **16**:698
97. Maguire RJ (1984) *Environ Sci Technol* **18**:291
98. Braman RS, Tompkins MA (1979) *Anal Chem* **51**:12
99. Ridley WP, Dizikes LJ, Wood JM (1977) *Science* **197**:329
100. Guard HE, Cobet Ab, Coleman WM (1981) *Science* **213**:710
101. Boettner EA, Ball GL, Hollingsworth Z, Aquino R (1982) Report OH EPA-600/SL-81-602. Health Effects Research Laboratory, US Environmental Protection Agency, Cincinatti, OH
102. Seidel LS, Hodge VF, Goldberg ED (1980) *Thalassia Jugoslavia* **16**:209
103. Valkirs AO, Seligman PF, Stang PM, Homer V, Lieberman SH, Vafa G, Dooley CA (1986) *Mar Pollut Bull* **17**:319
104. Dooley CA, Homer V (1983) Organotin compounds in the marine environment: uptake and sorption behaviour. Technical report no. 917. Naval Ocean Systems Center, San Diego, CA, USA
105. Valkirs AO, Seligman PF, Olsen GJ, Brinckman FE, Matthias CL, Bellama JM (1987) *Analyst* **112**:17
106. Burns DT, Harriott M, Glockling F (1987) *Fresen Z Anal Chem* **327**:701
107. Schulze G, Lehmann C (1994) *Anal Chem* **288**:215
108. Meinema HA, Burger N, Wiersina T (1978) *Environ Sci Technol* **12**:288
109. Jackson JA, Blair WR, Brinckman FE, Iveson WP (1982) *Environ Sci Technol* **16**:111
110. Aue WA, Flinn GC (1977) *J Chromatogr* **142**:145
111. Huey C, Brinckman FE, Grim S, Iveson WP (1974) In: Freitas ASW, Kushner DJ, Quadri DSU (eds) Proceedings of the international conference on the transport of persistent chemicals in aquatic ecosystems. National Research Council of Canada, Ottawa, pp II-73-II-78
112. Nelson JD, Blair W, Brinckman FE et al. (1973) *Appl Microbiol* **26**:321
113. Brinckmann FE (1981) In: Wong CS et al. (eds) Proceedings of a NATO advanced research institute on trace metals in seawater, Sicily, Italy. Plenum Press, New York
114. Dowling TM, Uden PC (1993) *J Chromatogr* **644**:153
115. Vercauteren J, Peres C, Devos C, Sandra P, Vanhaeke F, Moens L (2001) *Anal Chem* **73**:1509
116. Ebdon L, Alonso G (1987) *Analyst* **112**:1551
117. Smith JD (1970) *Nature* **225**:103
118. Duhamel K, Blanchard G, Dorange G, Martin G (1987) *Appl Organometall Chem* **1**:133
119. Kenis A, Zirino A (1983) *Anal Chim Acta* **149**:157
120. Luskina BM, Syavtsillo SV (1969) *Nov Obl Prom-Sanit Khim* **186**
121. Waggon H, Jehle D (1975) *Nahrung* **19**:271
122. Laughlin RB, Guard HE, Coleman, WM (1986) *Environ Sci Technol* **20**:201
123. Bluden SJ, Chapman AH (1978) *Analyst* **103**:1266

124. Ochsenkuhn-Petropolu M, Ochsenkuhn KM, Parissakis G, Glannakis An, Smith HD (1995) *Canadian J Appl Spectros* **40**:66
125. Nagase T, Tao H, Imagawa T, Miyazaki A (1992) *Shigei to Konkyo* **1**:263
126. Schintu M, Kauri T, Contu A, Kudo A (1987) *Ecotox Environ Safe* **14**:208
127. Hammerschmidt CR, Fitzgerald WF (2001) *Anal Chem* **73**:5930
128. Encinar JR, Villar MIM, Santamaría VG, Alonso JIG, Sanz-Medel A (2001) *Anal Chem* **73**:3174
129. McAvoy DC, Schatowitz B, Jacob M, Hauk A, Eckhoff WS (2002) *Environ Toxicol Chem* **21**:1323
130. Pocurull E, Brossa L, Borrull F, Marcé RM (2000) *J Chromatogr A* **885**:361
131. Ferrer I, Barcelo D (1999) *J Chromatogr A* **854**:197
132. Tao H, Rajendran R, Quetel CR, Nakazato T, Tominaga M, Miyazaki A (1999) *Anal Chem* **71**:4208

11 Elemental Analysis

11.1

Boron

Ball et al. [1] have described a method for determining down to 20 µg/l boron in estuarine waters. A dc argon plasma emission spectrometer was used. Quenching of the plasma by high solute concentrations of easily ionised elements such as alkali metals, as well as high and variable electron density, may be avoided by dilution. The method was found to be more sensitive, equally precise, less subject to interference and with a wider linear analytical range than the carmine spectrophotometric method. Very few interferences were noted when this technique was tested. There is a minor interference from the differential enhancement of tungsten relative to boron in solutions containing high concentrations of alkali metals. The effect of this is to increase the background when estuary water is being analysed, and it can be mitigated by using synthetic estuary water as a blank, by dilution, or by analysis by the method of standard additions.

An oscillographic method gave a detection limit of 3×10^{-9} mol/dm⁻³ and a linear range of 3×10^{-9} to 7×10^{-7} mol/dm⁻³ in the determination of boron in seawater.

Traces of boron in seawater have been determined by flow injection analysis with spectrophotometric detection at 415 nm using G 30 methine H. The linear range was 1 – 10 mg/l boron with a detection limit of 0.017 mg/l [3].

11.2

Total Iodine

Schnepfe [4] has described a method for the determination of total iodine and iodate in seawater. One per cent aqueous sulfamic acid (1 ml) is added to seawater (10 ml), then it is filtered, if necessary, and the pH adjusted to 2. After 15 min, 1 ml 0.1 M sodium hydroxide and 0.5 ml 0.1 M potassium permanganate are added and the steam bath heated for 1 h. The cooled solution is filtered, the residue washed, the filtrate plus washings is diluted to 16 ml and 1 ml of a 0.25 M phosphate solution (containing 0.3 µg iodine as IO₃⁻ per

ml) added at 0 °C, then 0.7 ml 0.1 M Fe¹¹ in 0.2% (v/v) sulfuric acid, 5 ml 10% aqueous sulfuric acid–phosphoric acid (1:1) at 0 °C, and 2 ml starch–cadmium iodide reagent are added. The solution is diluted to 25 ml and after 10–15 minutes the extinction of the starch–iodine complex is measured in a 5 cm cell. For iodate the procedure is as described above except that the oxidation stage with sodium hydroxide–potassium permanganate is omitted and only 0.2 ml Fe solution is used; iodate standards were used in both procedures. The total iodine procedure is relatively free from interference by foreign ions but the iodate procedure is affected by bromate and sulfite. Down to 0.1 µg iodine can be determined in the presence of 500 mg chloride and 5 mg bromide by this procedure.

The classical method for the determination of iodide in seawater was described by Sugawara [5]. Various workers [6, 7] have improved the original method. Matthews and Riley [6] modified the method by concentrating iodide by means of coprecipitation with chloride using silver nitrate (0.23 g per 500 ml seawater). Treatment of the precipitate with aqueous bromine and ultrasonic agitation promote recovery of iodide as iodate which [15] when reacted with excess of iodide ions under acid conditions, yields I₃⁻, which are determined either spectrophotometrically or by photometric titration with sodium thio-sulfate. Photometric titration gave a recovery of 99.0 ± 0.4% and a coefficient of variation of ±0.4% compared with 98.5 ± 0.6% and ±0.8%, respectively, for the spectrophotometric procedure.

Tsunogai [7] carried out a similar coprecipitation allowing a 20-hour standing period to ensure that iodide is fully recovered in the silver chloride coprecipitate. Again, the iodide is oxidised to iodate prior to spectrophotometric determination of the latter. This procedure also includes a step designed to prevent interference by bromine compounds.

Kesari et al. [8] have recently described a sensitive spectrophotometric method for determining iodine in seawater.

11.3 Organic Nitrogen

The quantification of nitrogen in its soluble organic forms has interested marine chemists engaged in hydrographic, primary production and pollution studies [20, 21]. The concentrations of particular dissolved organic nitrogen species in seawater may be low, and while methods have been developed for some specific compounds (notably the amino acids) the bulk of the dissolved organic nitrogen remains uncharacterised. Whilst a large portion of the dissolved organic nitrogen in seawater is probably derived from soluble exudates from algae, it will also contain a wide range of other compounds including animal proteins, urea, and other excretory products, nucleic acids, etc.

Dissolved Organic Nitrogen is Commonly Determined in Four Stages:

1. Removal of particulate organic nitrogen by filtering through a 0.45 μm pore membrane or equivalent glass-fibre filter
2. Oxidation of soluble organic nitrogen to inorganic forms of nitrogen
3. Determination of total inorganic nitrogen
4. Correction for inorganic nitrogen species present before oxidation.

The micro Kjeldahl method involves reducing all of the organic nitrogen to ammonia, then distilling the ammonia into an absorbing solution and determining it colorimetrically [11, 12, 22].

A comparative study of the variations in final measurements of ammonia has been carried out by Astrani [9]; a Russian version [10] could also be used for the measurement of organic nitrogen in particulate matter.

Mertens et al. [11] and Stevens [12] designed semiautomated versions of the micro Kjeldahl which avoided the distillation step altogether. In their versions, after the digestion step the digestion solution was diluted and the ammonia determined with an ammonia probe. The limitation on the sensitivity, then, is the sensitivity of the ammonia probe. This limits the method to the more productive oceanic waters.

Another approach to the organic nitrogen problem is to use persulfate wet oxidation to convert the nitrogen to nitrate or nitrite, in place of the reduction to ammonia [13, 14, 24, 25]. Results are fully comparable with those from the micro Kjeldahl digestion but the technique is far simpler. The precision should also be higher, since the final step in the measurement, the colorimetric determination of nitrite, is much more precise than any of the ammonia methods.

The Adamski [13] procedure is semiautomated. It gives an accuracy of $\pm 8.1\%$ and a precision of $\pm 8.2\%$ for seawater samples spiked with 3–35 $\mu\text{g/l}$ organic nitrogen. This procedure is based on the indophenol blue method and was employed using a Technicon AutoAnalyzer II system with the appropriate accessories. Various workers have described automated procedures for determination of low levels of organic nitrogen in seawater [15, 16].

Ultraviolet photo-oxidation techniques can be used as a method for organic nitrogen. The organic nitrogen compounds are oxidised to nitrate and nitrite then determined by the standard seawater analysis methods [17, 18, 23].

The oxidation of urea was not complete. The incomplete step in the photolysis of urea is much more likely to be hydrolysis of urea to produce ammonia, since the oxidation of ammonia is known to occur under the conditions of the experiment.

If the freeze drying method for total organic carbon devised by Gordon and Sutcliffe [29] is used with the final determination of carbon being run on a commercial CHN analyser, the analysis of total nitrogen is also obtained. If analyses for the inorganic nitrogen compounds have also been run on the sample, organic nitrogen can be calculated by difference.

Of the methods in common use, the two wet oxidation methods offer the best possibilities for further development. The photo-oxidation method in particular is well suited to automatic analysis. In the version of the total organic carbon method published by Collins and Williams [30] the effluent from the quartz photolysis coil could as easily be diverted to the nitrate analysis unit; if inorganic nitrogen were also measured, organic nitrogen could become a routine automatic method.

Shepherd and Davies [26] have described a semiautomated version of the alkaline peroxodisulfate procedure for the determination of total dissolved organic nitrogen in seawater. These workers carried out experiments on a range of contaminated and clean seawaters using a version [27] of Koroleff's [24] alkaline peroxodisulfate oxidation technique.

Shepherd and Davies [26] made some modifications to the Nydahl method to make it applicable to the automated routine analysis of small samples of natural and polluted seawater, and to samples of contaminated saline effluents.

Nydahl [28] published a list of 39 compounds which gave oxidation yields over 87% in distilled water compared with the Kjeldahl nitrogen determination. He also included eight compounds which gave poor (< 83%) recoveries and concluded that yields from peroxodisulfate oxidation are low for compounds containing nitrogen–nitrogen bonds and $\text{HN} = \text{C}$ groups. The determination of total dissolved nitrogen at the $10 \mu\text{g N dm}^3$ level for potassium nitrate, potassium nitrite, urea, glycine, 2, 2'-bipyridyl, and disodium EDTA added as spikes to natural seawater gave recoveries of 88–113% at a total dissolved nitrogen concentration of $15.3 \mu\text{g N dm}^{-3}$. The detection limit was $0.18 \mu\text{g N dm}^{-3}$, i.e. 23 ng N per sample.

Nakamura and Namiki [32] have determined total nitrogen in seawater by ultraviolet spectrophotometry and correcting for background absorbance due to bromide ion. Total nitrogen has been determined in seawater by oxidising the sample with potassium persulfate, boiling with sulfuric acid and potassium permanganate at pH 1.3 to remove bromide and bromate, removal of excess permanganate and manganese dioxide with sodium thiosulfate and measuring the absorbance of the treated solution at 220 nm [31].

Frankovitch and Jones [33] have presented a rapid automated method for the determination of total combined nitrogen in seawater. The method has a detection limit of 2 μM .

11.4 Organic Phosphorus

The earlier methods for the measurement of organic phosphorus generally used fairly drastic measures to decompose the organic compounds present and free the phosphates. For example, Duursma [34] used the technique originally described by Harvey [35] which included autoclaving the seawater with sulfuric acid at 140°C for 6 h, at a pressure of 3 atmospheres. These methods required

great care and a good deal of time; as a result, organic phosphorus was never a routine determination.

Photo-oxidation was seen as a possible route to a total phosphorus method. Again, early work on the method was done by Armstrong et al. [15] and Armstrong and Tibbitts [36]. Grasshoff [37] adapted the method to continuous automatic analysis; a variation on this method is considered the “standard” method for automatic analysis today [18]. Bikhulatov [38], on the other hand, feels that such important phosphorus compounds as ATP and DI are not completely decomposed by ultraviolet irradiation and that persulfate oxidation gives better results.

Both the persulfate and ultraviolet oxidation methods have much to recommend them. Ultraviolet photo-oxidation methods have an advantage in that they are easily automated.

The simultaneous determination of dissolved organic carbon and phosphorus is feasible [39]. Phosphoglyceric acid (1 g equivalent P) was added to membrane-filtered, pre-irradiated seawater, and the phosphate was measured before and after ultraviolet irradiation using an autoanalyser. The recovery of organic phosphorus was 100%.

Cembella et al. [40] have described a method for the determination of total phosphorus in seawater. The procedure used magnesium nitrate to oxidise organic compounds before standard molybdate colorimetric determination of *ortho*-phosphate. The method was applied to several pure organic phosphorus compounds and gave 93–100% recovery of phosphorus.

Ormaza-Gonzales et al. [41] compared methods for determining dissolved and particulate phosphorus in seawater.

11.5 Silicon

Silicon has been determined directly in seawater by inductively coupled plasma atomic emission spectrometry with a detection limit of 0.3 μm silicon [42].

11.6 Total Sulfur

Taylor and Zeitlin [43] described an X-ray fluorescence procedure for the determination of total sulfur in seawater. They studied the matrix effects of sodium chloride, sodium tetraborate, and lithium chloride and show that the X-ray fluorescence of sulfur in seawater experiences an enhancement by chloride and a suppression by sodium that fortuitously almost cancel out. The use of soft scattered radiation as an internal standard is ineffective in compensating for matrix effects but does diminish the effects of instrument variations and sample inhomogeneity.

11.7 Carbon Functions

The quantity of dissolved organic carbon in the oceans has been estimated to be about 10^{18} g and constitutes one of the major reservoirs of organic carbon. Although large in total mass, the concentration of organic carbon in seawater is low (typically 0.5–1.5 mg C per litre).

The determination of organic carbon has always presented analytical difficulties. The content of inorganic carbon present in seawater is thirty or more times as great as that of organic carbon. To measure the organic carbon, either the organic or the inorganic carbon must be removed from solution. The retention of even a small percentage of the inorganic carbon could easily double or triple the apparent organic carbon content of a sample. While this observation might seem obvious, it is a fact that several workers have described methods in which the organic carbon was determined as the difference between a total and an inorganic carbon measurement, and where the measurement of inorganic carbon had been incomplete. The resulting dissolved organic carbon values were too high by a factor of up to 10.

Even if removal of inorganic carbon is complete, the analysis of the remaining carbon is difficult. At a concentration of 1 ppm, a normal value for surface water in the open ocean, a 1 ml sample will contain 1 μ g carbon. If we are interested in differences between samples, we must strive for a precision of $\pm 5\%$ or ± 0.05 μ g C per ml sample. This requirement places severe constraints on the sensitivity and precision of instrumentation.

Since any attempt to measure the productivity of a marine ecosystem must eventually require measurements of organic carbon in the various reservoirs of the system, an extensive literature exists on methods for the measurement of organic carbon. The methods usually distinguish between total organic carbon (TOC), particulate organic carbon (POC), dissolved organic carbon (DOC), and volatile organic carbon (VOC). These are discussed below under separate headings. A review of the available methods for all of these components up to 1975 was published by Wangersky [44], and up to 1993 by Ogawa [45].

Both biochemical oxygen demand and chemical oxygen demand are measurements frequently made in water laboratories. Both of these methods are subject to interference when applied to saline samples, as is discussed in the concluding section in this chapter.

11.7.1 Dissolved Organic Carbon

Because they are so intimately related, for the purposes of this discussion, the categories of “total” and “dissolved” organic carbon are combined in this section. Also it is doubtful in any case that anyone ever measures a true “total” organic carbon in seawater. The total organic carbon should include

the dissolved, particulate, and volatile organic fractions; in the process of removing the inorganic carbon, usually by acidification and bubbling, some portion of the volatile organic carbon must be removed. Thus the total organic carbon as measured by direct determination must always be the total minus the volatile fraction.

The determination of dissolved organic carbon by oxidation methods in water comprises three analytical steps: the removal of inorganic carbon from the sample, oxidation of the organic compounds to carbon dioxide, and the quantitative determination of the resulting carbon dioxide. The methods of oxidation can be classified into three major groups:

1. Wet chemical oxidation methods, using oxidants such as persulfate, are widely used in oceanographic and limnologic work [46,47]. The main drawbacks of these methods are their manual and cumbersome techniques and incomplete oxidation of some organic compounds [48].
2. High-temperature combustion, or dry oxidation methods developed for fresh and wastewater analysis, led to a whole range of discontinuous [49,50] and continuous [51,52] commercial instruments. The discontinuous injection method lack in sensitivity and show high blank values [53], whereas the continuous combustion methods, with high sensitivity, do not tolerate the high ionic strength of seawater, even if designed for analysis of highly buffered high-pressure liquid chromatography eluate [54].
3. The photo-oxidation of dissolved organic carbon in batch procedures [56,57] requires long reaction times, because of the thickness of the sample. Automated, continuous procedures, where the sample is irradiated by a "medium pressure" mercury lamp [30,57] brought great improvement and are utilised in several commercial instruments.

The merits and limitations of wet chemical oxidation, high-temperature combustion, and photo-oxidation methods for seawater analysis were summarised by Gershey et al. [58].

The specifications for the future development of a sensitive, accurate, and automated method were suggested by Wangersky [59].

The various methods used for the determination of total and dissolved organic carbon are now discussed under separate headings.

Ultraviolet Absorption

Armstrong and Boalch [60] have examined the ultraviolet absorption of seawater, particularly in the wavelengths between 250 and 300 nm, where the absorption is considered to result from the presence of aromatic compounds. Light absorption is a particularly useful measure, if it can be made to work, since it is not too difficult to construct an in situ colorimeter which can produce continuous profiles of dissolved organic carbon with distance or depth [71].

Ogura and Hanya [62–65] investigated the components of the ultraviolet absorption in an attempt to devise a useful method for oceanic dissolved organic carbon measurements. They concluded that while the method might have limited application in coastal waters, most of the absorption in oceanic waters was due to the inorganic components, principally nitrate and bromide ions.

The method has since been revived for use in fresh water [65], where comparisons with total organic carbon determinations by direct injection showed the ultraviolet method to give results that were slightly high (3.8%), with a fairly large scatter ($sd = 19\%$ of the mean). Mattson et al. [66] applied a variant of the method to coastal water, again calibrating against a direct injection total organic carbon method, and claimed reasonable results. However, Wheeler [67] found that correlations between total organic carbon and ultraviolet absorption, while quite strong over limited geographical regions, could switch from positive to negative in adjacent regions.

Kulkarni [68] described an ultraviolet absorption method for the measurement of the organic carbon level in seawater which compares the intensities at two wavelengths, one less than 350 nm and the other greater than 400 nm.

Biggs et al. [69] compared various instrumental methods for monitoring organic pollution in water. These included total organic carbon, total oxygen demand, chemical oxygen demand, and biochemical oxygen demand, and an ultraviolet method based on measurements of the ratio of the light transmitted by the sample at 254 nm in the ultraviolet to that at 510 nm in the visible region. The results obtained by the ultraviolet method were claimed to be largely independent of the presence of inert suspended solids in the sample. They also showed that reasonably good correlations were obtained between ultraviolet absorbance at 254 nm on the one hand and total organic carbon, or biochemical oxygen demand or chemical oxygen demand on the other. Although these investigations were performed only on sewage effluents, this could be used as a rapid monitoring procedure for total organic carbon in seawater.

Wet Oxidation Methods

Another group of attractive techniques for determining total organic carbon are those using wet oxidation of the organic carbon to carbon dioxide. In these methods, the inorganic carbon is first removed by acidification and gas purging to remove carbon dioxide produced by the decomposition of metallic carbonates. The wet oxidation of organic carbon is then carried out by the addition of the preferred oxidant, usually with heating, and the carbon dioxide resulting from the oxidation is measured by various methods.

Several different oxidants have been used in this work. The trend has been to stronger oxidants, in the hope that more complete oxidation would result. Among those used have been potassium peroxide [69], dichromate in sulfuric acid [70–73], silver-catalysed potassium dichromate [74, 75], potassium per-

sulfate [38], and silver-catalysed potassium persulfate [77,78]. Similarly, many methods for measuring the evolved carbon dioxide have been devised, such as titration of the oxidant consumed by coulometric titration (Duursma [74]), and conductometry and gas chromatography [72,76]. By far the most popular, however, has been the non-dispersive infrared gas analyser [78,79].

Low-temperature ultraviolet-promoted chemical oxidation has provided more reliable and precise data in the determination of low $\mu\text{g/l}$ levels of total organic carbon [56,78].

These instruments employ a continuous flow of persulfate solution to promote oxidation prior to ultraviolet irradiation, and have a low system blank and low detection limit. Since all reactions take place in the liquid phase, problems suffered by combustion techniques, such as catalyst poisoning, reactor corrosion, and high-temperature element burnouts, are obviated. However, the ultraviolet-promoted chemical oxidation technique is not designed to handle particulate-containing samples, and tends to give incomplete oxidation for certain types of compounds such as cyanuric acid.

While the precision of these methods, of the order of ± 0.1 mg C per litre, is not high enough for purposes of maintaining budgets on various fractions of the total organic carbon, it is certainly good enough to provide some idea of world-wide distributions. The great disadvantage of all wet oxidation methods is the uncertainty of completeness of oxidation. Each change to a more powerful oxidant has been made with the implicit assumption that this particular oxidant would finally work on all of the compounds and give total organic carbon values equivalent to total combustion values. In the absence of a recognised referee method, the only checks on the completeness of oxidation have come from the oxidation of known pure compounds and from the oxidation of ^{14}C -labelled material derived from plankton cultures. Both of these techniques seem to show essentially total oxidation by the high-temperature persulfate method [47].

There is considerable controversy concerning the completeness of the wet oxidation. Some of this controversy has centred on the calculation of the blank value for the method. One method for the preparation of organic-free water consists of the oxidation of the residual organic matter with phosphoric acid and persulfate in the process of distillation. This procedure should produce water that is immune to further oxidation with the same reagents, and therefore produce zero blanks. However, many workers using total combustion techniques have found that small but measurable amounts of organic carbon are resistant to this, or to any other, wet chemical oxidation. This is not surprising, since there are a number of organic compounds that are not completely oxidised even under much more stringent conditions, such as boiling with nitric and perchloric acids for periods of up to 45 min and at temperatures up to 203°C [80].

While there have been very few intercalibration studies done between the various kinds of methods, the few available comparisons suggest that both the ultraviolet irradiation method and the various total combustion methods

discussed in later sections find more organic carbon than do the chemical wet oxidation methods.

However, the work of Menzel and Vaccaro [46] and others [15, 81] suggests that wet oxidation is useful for determining the dissolved organic content of seawater samples, and the oxidation has been shown to be essentially complete [82]. Seawater is first freed of inorganic carbon by treatment with a small volume of 3% phosphoric acid, and the organic carbon is then oxidised in sealed glass ampoules in an autoclave at 130 °C using potassium persulfate as an oxidant. The resulting carbon dioxide is passed through a non-dispersive infrared analyser whose signals are related to milligrams of carbon in the sample.

Hannaker and Buchanan [82] used a method based on wet oxidation with potassium persulfate [83] for the determination of dissolved organic content in concentrated brines following the removal of inorganic carbonates with phosphoric acid. The method involves wet oxidation with potassium persulfate at 130 °C followed by a hot copper oxidation and gravimetric measurement of the carbon dioxide produced. The technique overcomes difficulties of calibration curvature, catalytic clogging, and instrument fouling often encountered with instrumental methods.

Low-volatility natural organic material such as polysaccharides and higher molecular weight proteins sometimes produced low results. In the Hannaker and Buchanan method [82] these problems are overcome by using a solution-phase oxidant and enclosing the system in a sealed tube. In this way all of the constituents are fully contained and exposed to oxidation and, moreover, oxidation of the organic matter to carbon dioxide is complete for the greater majority of compounds.

Hannaker and Buchanan [82] differ from Menzel and Vaccaro [46] in that they use Carbosorb or soda asbestos tubes to estimate the carbon dioxide produced, instead of the non-dispersive infrared analyser used by the latter workers.

Using this method, a series of organic species were measured at various concentrations.

The results presented in Table 11.1 show that very close agreement was obtained for a variety of organic compounds both with and without sodium chloride present.

Ultraviolet Irradiation Methods

Another promising wet oxidation method uses high-intensity ultraviolet light in the presence of an oxidising agent such as hydrogen peroxide or potassium persulfate. This method was proposed by Beattie et al. [55], who used a mass spectrometer as a detector for the carbon dioxide produced. Armstrong and his co-workers adapted the method to seawater and showed that the method gave essentially the same results as the persulfate oxidation [15,23]. They noted the incomplete oxidation of urea, using this technique.

Table 11.1. Analysis of a series of organic species at various concentration levels, with and without NaCl present [82]

Organic compound tested	Range tested, ppm	NaCl range, ppm	No. of samples tested	Percentage mean recovery
Mannitol	54–432	0–300	10	98.4
Acetic acid	30–720	0–300	11	97.9
D-tartaric acid	76–604	0–300	9	102.7
Oxalic acid	57–1140	0–300	7	100.9
Malic acid	36–716	0–300	9	99.0
Propan-2-ol	45–180	0–300	4	94.4
Acetylacetone	232–465	0–300	4	99.8
Ethanol	208–417	0–300	4	98.1
Glycine	10–382	0–300	10	95.5
Glycerol	10–392	0–300	9	98.7
Trisodium citrate	123–490	0–300	7	96.0
Salicylic acid	42–406	0–300	9	98.3

Williams [81,84] found that a high-energy ultraviolet oxidation method gave dissolved organic carbon results for seawater samples that were higher than those obtained by the wet persulfate oxidation method described by Menzel and Vaccaro [46]. Other variations on the method have been published.

One of the great advantages of this method is that it is easily adapted for automatic analysis [30,57,78]. Ehrhardt [57] detected generated carbon dioxide by a conductometric method, Collins and Williams [30] used an infrared analyzer, and Armstrong and Tibbits [23] and Goulden and Brooksbank [78] used a continuous photoelectric method. A disadvantage of these automatic methods is that owing to long irradiation times, there is a considerable lag between the intake of the first sample and obtaining the first result.

An example of an automated colorimetric method, oxidation by ultraviolet irradiation for the determination of dissolved organic carbon in the presence of potassium persulfate [87], is that of Schreurs [86]. The method uses a Technicon analyser to measure dissolved organic carbon, is fast and precise, and may be used to measure dissolved organic carbon in both seawater and fresh water over the range 0.1–10 mg C per litre.

In this method the sample is acidified and the inorganic carbon is removed with nitrogen. An aliquot is resampled for analyses. Buffered persulfate is added and the sample is irradiated in the ultraviolet destructor for about 9 min. The hydroxylamine is added and the sample stream passes into the dialysis system. The carbon dioxide generated diffuses through the gas-permeable silicon membrane. A weakly buffered phenolphthalein indicator solution is used as the recipient stream, and the colour intensity of this solution decreases proportionately to the change in pH caused by the absorbed carbon dioxide

gas. The measurement of the colour intensity is done in a 15 mm flow cell at 550 nm.

Linear response to within 0.1% of the theoretical least-squares fit line is obtained with the intercept passing through zero.

Recoveries were obtained for a range of organic compounds representing various organic classes and containing a variety of functional groups. These organic compounds with a concentration of 2 and 4 mg C per litre were dissolved in standard seawater. Recovery was measured against potassium hydrogen phthalate standards. The average recovery is 98.9%. Mueller and Bandaranayake [39] reported on an automated method for the determination of dissolved organic carbon in seawater using continuous thin-film ultraviolet oxidation in a quartz spiral ultraviolet "low-pressure" mercury lamp. Tests with a range of organic compounds showed that the instrument is capable of rapid, continuous, and reliable dissolved organic carbon analysis in seawater, and is suitable for use aboard a research vessel.

Mueller and Bandaranayake [39] were able to show that more than 95% of the following compounds were oxidised in the first run, when present in the water sample at the 5 mg C per litre level: oxalic acid, potassium phthalate, humic acid, glucose, sucrose, ascorbic acid, glycine, and phenol. Only sulfur compounds gave incomplete recoveries [58, 88].

A pH of 3 was optimal for the complete removal of inorganic carbon and the most efficient oxidation of nitrogen-free organic compounds, while a pH of 2.5 was optimal for nitrogenous compounds (Fig. 11.1).

These workers found that the efficiency of oxidation was a function of the residence time of the sample in the reactor and the flow rate of the carrier gas. A high precision of carbon dioxide determination was achieved at a sample flow rate of 50 ml/h and a carrier gas flow rate of 62 l/h, of which 40 l/h passes through the shielded zone.

Using this procedure, analysis can be completed in 5–10 minutes.

Evaporation–Dry Combustion

It seems that in principle the simplest of all possible total organic carbon methods would use acidification of the sample followed by evaporation and dry high-temperature combustion of the resulting sea salts. This method has been developed both for fresh water [89] and seawater [90]. The data for oceanic total organic carbon resulting from the latter method were considerably higher, by a factor of 2 or 3, than those coming from the wet oxidation methods. This difference was later ascribed to contamination of the samples by the apparatus and impurities in room air.

A method using vaporisation at low temperature in an atmosphere of organic-free gas, an extension of the method of Skopintsev and Timofeyeva [90], was developed by MacKinnon [91]. Contamination from organic vapours in the laboratory air was a major problem; as soon as this was understood, and

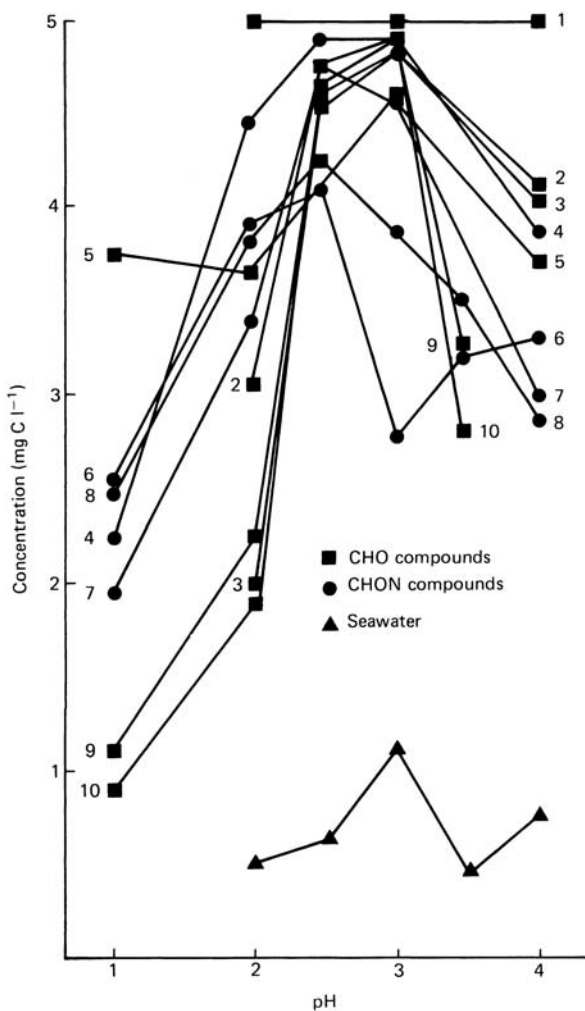

Figure 11.1. Effect of pH on the oxidation of organic compounds. 1 Oxalic acid. 2 Potassium phthalate. 3 Ascorbic acid. 4 Humic acid. 5 Phenol. 6 Guanidine. 7 Glycine. 8 Urea. 9 Glucose. 10 Sucrose. Nitrogen-free compounds peak at pH 3, nitrogen-containing compounds at pH 2.5. The seawater sample was collected from Myrmidon Reef, 80 km north of Townsville, Australia. Source: [39]

sufficient care was given to safeguarding the evaporation process, both accuracy and precision reached reasonable levels. Comparisons were run between this dry combustion method and the Sharp [58] version of the persulfate wet oxidation method. The dry combustion method gave results consistently 15–25% higher than persulfate wet oxidation. On water from the same parts of the ocean, the values were well below those found by Skopintsev and Timofeyeva [90] and Gordon and Sutcliffe [29].

MacKinnon [92] has described a high-temperature oxidation method for the accurate and precise determination of the total organic carbon in seawater. Problems of contamination in sample storage, preparation, and oxidation which are evident in previous dry oxidation methods were controlled. The total organic carbon results from different areas are determined and compared directly with the results obtained by the persulfate oxidation method. A high correlation between the two methods was obtained. In this method, the organic matter is oxidised to carbon dioxide, in an oxidation similar to that of Skopintsev [93], after a sample preparation similar to that of Gordon and Sutcliffe [29]. The oxidation products are determined with a non-dispersive infrared detector. Values obtained by this procedure are similar to the lower values obtained by Sharp [58] with his high-temperature combustion method. In the method by Gordon and Sutcliffe [29] the aqueous sample is evaporated to dryness by freeze-drying, and the resulting salt is oxidised in a high-temperature furnace.

MacKinnon [92] carried out a very detailed study in which sample collection and storage, sample preparation, the dry oxidation procedure, water corrections, adsorption effects, and precision and accuracy are all discussed in detail.

Comparison of Results Obtained by Evaporation–Dry Combustion and Ultraviolet Photo-oxidation

Initially, results reported for dry-combustion methods were found to be higher than wet-oxidation methods based on persulfate by factors of 2 or more. This discrepancy has steadily decreased as methodologies have improved. Contamination problems of dry methods have been reduced and the oxidation efficiency of the wet methods has been improved. While the differences between approaches have been discussed [94, 95], there is still uncertainty whether the remaining difference between the two techniques is real – a result of incomplete oxidation, incorrect estimation of blanks, or a combination of both.

Collins and Williams [30] have recently described a modification of Ehrhardt's earlier photochemical method [57], which offers the practical advantages of speed, convenience, and the potential for "real-time" analyses. However, until the accuracy of the results is established, the method will not receive general acceptance. Collins and Williams [30] examined the completeness of oxidation of their photo-oxidation system using three independent methods, but pointed out that while essentially complete oxidation was indicated, definitive proof was lacking. A more satisfactory solution to the problem might be found through comparison of results of the photo-oxidation method with the dry-combustion method, which most analysts are willing to accept as complete [96].

In this connection, Gershey et al. [58], in a detailed study, have compared results obtained for dissolved organic carbon in seawater using the evaporation–

dry combustion method of MacKinnon [92], the ultraviolet photochemical method of Collins and Williams [30] (slightly modified), and the persulfate oxidation method of Menzel and Vaccaro [46] and Sharp [48].

Gershey et al. [58] have shown that the agreement among the three techniques for analysis of dissolved organic carbon in seawater is generally good, considering the problems inherent in this type of trace analysis. Taking their results and those of Goulden and Brooksbank [78] together, one can conclude that the difference between the results of the dry combustion and photo-oxidation methods is small and of little practical consequence.

The versions of the persulfate oxidation methods used at present yield results that are lower than those obtained using the dry combustion or photo-oxidation techniques (Table 11.2). Close agreement between the persulfate and other methods is obtained when the analyses are carried out on freshwater rather than seawater samples. If the persulfate oxidation procedure is to be retained as a method for seawater analysis, serious consideration should be given to abandoning the present batchwise procedure in favour of an automated procedure.

Table 11.2. Comparison of the different oxidation methods for analysis of organic carbon in filtered and unfiltered seawater

Area	<i>n</i>	Averaged organic carbon concentration (mg C per l)			Difference by paired <i>t</i> -test at 95% confidence level
		Dry oxidation [105]	Photo- oxidation [61]	Persulfate oxidation [49]	
Scotian shelf (0–500 m) (31–35‰)	25	–	0.85 ± 0.14	0.77 ± 0.13	S
	26	0.88 ± 0.13	0.85 ± 0.14	–	NS
	25	0.88 ± 0.13	–	0.77 ± 0.13	S
<i>Coastal area</i>					
(a) filtered (DOC)	9	–	1.26 ± 0.06	1.12 ± 0.10	S
	9	1.31 ± 0.08	1.26 ± 0.06	–	NS
	9	1.31 ± 0.08	–	1.12 ± 0.10	S
(b) unfiltered (TOC)	5	–	1.41 ± 0.15	1.38 ± 0.21	NS
	5	1.68 ± 0.19	1.41 ± 0.15	–	S
	5	1.68 ± 0.19	–	1.38 ± 0.21	S

S: Significant

NS: Not significant

DOC: Dissolved organic carbon

TOC: Total organic carbon

Source: [58]

Gershey et al. [58] concluded that a continuous and automated photo-oxidation procedure of the type described by Collins and Williams [30], with the reported modifications, will probably satisfy most of the needs of the oceanographer concerning measurement of dissolved organic carbon. The convenience and rapidity of the method opens up a new area of research: the study of the small-scale temporal and spatial variations of the dissolved organic carbon content of the oceans.

Dry Combustion Direct Injection Methods

These procedures differ from the evaporation–dry combustion procedures described in the previous section as follows.

Evaporation–Dry Combustion

Inorganic carbonate is removed by acid addition, evaporated at fairly low temperature to a dry sea salt residue, and the residue combusted to carbon dioxide in a high-temperature furnace.

Dry Combustion–Direct Injection

Inorganic carbonate is removed by acid addition, and the acidified liquid sample is injected directly into a high-temperature furnace.

The dry combustion–direct injection technique provides many advantages over other methods, such as quick response and complete oxidation for determining the carbon content of water. Its primary shortcoming is the need for rapid discrete sample injection into a high-temperature combustion tube. When an aqueous sample is injected into the furnace, it is instantaneously vapourised at 900 °C and a 5000-fold volume increase can be expected. Such a sudden change in volume causes so-called system blank and limits the maximum volume of injectable water sample, which in turn limits the sensitivity [106, 107].

A dry combustion–direct injection apparatus was applied to water samples by Van Hall et al. [51]. The carbon dioxide was measured with a non-dispersive infrared gas analyser. Later developments included a total carbon analyser [97], a diffusion unit for the elimination of carbonates [98], and finally a dual tube which measured total carbon by combustion through one pathway and carbonate carbon through another. Total organic carbon was then calculated as the difference between the two measurements [99].

Van Hall et al. [100] inject a 20 litre sample into a high-temperature furnace at 950 °C containing catalyst to promote oxidation of carbon compounds to carbon dioxide, which is then passed into a non-dispersive infrared analyser. The carbonate interference can be determined by passing an acidified portion of the sample through a low-temperature furnace [101–103].

One of the best-known commercial instruments developed for organic carbon determinations is the Beckman total carbon analyser, which utilises an analysis scheme developed by Van Hall and co-workers [57, 99]. This instrument works reasonably well in fresh water. It has become a standard instrument in pollution control and water treatment [103]. The Beckman instrument has not worked as satisfactorily for seawater because of the latter's high carbonate and low organic content.

Another instrument developed by the Precision Scientific Co. was based upon the work of Stenger and Van Hall [99, 104]. Experience has shown that application of the Beckman and Precision Scientific Co. instruments to concentrated or saturated brine solutions leads to erratic and unreliable results. There are several possible reasons for this: (1) the catalyst will rapidly become coated with sodium chloride; (2) oxidation of Cl^- to chlorine will occur; and (3) volatile organics may not all be trapped by the solid catalyst.

Van Hall, Safranko, and Stenger [51] have also pointed out that strong brines interfere with the method by producing "fogs" which may be counted as carbon dioxide, while in cases where the flame ionisation detector is being used, large spikes appear in the recorded curve [105].

Sharp [48] has described a dry combustion-direct injection system built for oceanographic analyses. This unit used 100 μl samples, injected into a 900 °C oven in an atmosphere of oxygen. The output from a non-dispersive infrared carbon dioxide analyser was linearised and integrated.

Ton and Takahashi [108] describe a dry combustion-direct injection total organic carbon analyser, the DC-90 (produced by Dohrmann Division, Xertex Corporation), which is claimed to overcome many of the problems encountered with earlier versions of this equipment. In this analyser, carrier water is continuously pumped into a ceramic combustion tube where a constant flow of oxygen is provided. The combustion tube is designed so that the carrier water is dispersed and instantaneously evaporated. A sample is introduced by either a rotary injection valve (via a sample loop) or by syringe into the carrier water stream. Thus gas and stream are maintained at constant flow. Carbonaceous materials in the sample are completely oxidised to carbon dioxide in the presence of oxygen, an oxidation catalyst, and a heat transfer device. After the stream is condensed, carbon dioxide in oxygen is subsequently measured by non-dispersive infrared spectroscopy. The carbon dioxide generated by complete combustion is directly proportional to the total carbon in the stream. Since a large sample volume can be injected without disturbing flow conditions, the system blank is negligible; thus high precision and sensitivity can be achieved. This continuous water carrier flow-high-temperature combustion technique works quite well for determining total organic carbon in samples such as seawater and brine solutions. The constant water flow prevents salt build-up, and deterioration of the combustion tube is eliminated by the use of a ceramic tube. Inorganic carbon can also be directly determined by injecting a sample into a gas/liquid separa-

tor. Total organic carbon can be determined either by externally acidifying and sparging the sample before analysis, or it can be calculated by taking the difference:

$$\text{Total organic carbon} = \text{total carbon} - \text{inorganic carbon}$$

Shimadzu supply a fully automated total organic carbon analyser, their Model TOC 500, based on dry combustion-direct injection followed by non-dispersive infrared spectroscopy. The system incorporates a microcomputer and has an optional automatic sample injector. The method is applicable to all waters, including seawater, and has a range of 1–3000 ppm. It is also applicable to the determination of volatile organic carbon. In this instrument flow-controlled and humidified carrier gas (highly pure air) is allowed to flow through the TTCU (total carbon) combustion tube, which is kept at 680 °C. Then the gas flows through the drain separator, where its moisture is removed, through the inorganic carbon reaction tube kept at 150 °C, and through the electronic dehumidifier, where its moisture is removed again. Finally, the gas flows through the cell of the non-dispersive infrared analyser, which measures the carbon dioxide concentration in the gas.

When a sample is injected into the total carbon injection port with a microlitre syringe, the carbon atoms in the organic and inorganic compounds in the sample are oxidised into carbon dioxide. The NDIR analyser generates a peaked signal with an area proportional to the carbon dioxide concentration. The built-in microcomputer measures the peak area and converts it into a total carbon concentration value by means of the calibrating equation predetermined through measurement of standard solution samples.

When a sample is injected into the inorganic carbon injection port, the sample enters the inorganic carbon reaction tube, where only the inorganic carbon is turned into carbon dioxide. The carbon dioxide concentration is converted into inorganic carbon concentration value in the same way as total carbon. The total organic carbon concentration is obtained by subtracting inorganic carbon concentration from total carbon concentration and printed out. With the optional volatile organic carbon measuring channel added, volatile organic carbon concentration is measured in the same way.

When the volatile organic carbon measuring channel is selected, the gas coming out of the total carbon combustion tube enters the volatile organic carbon evaporation tube, which is packed with volatile organic compound evaporation reagent and inorganic carbon absorbing reagent, and is kept at 150 °C. Then the gas flows through the heated tube into the volatile organic carbon combustion tube kept at 680 °C, and reaches the non-dispersive infrared analyser via the electronic dehumidifier. When a sample is injected into the volatile organic carbon injection port, only the volatile organic components are vapourised. Some inorganic carbon components generate carbon dioxide, which is absorbed by the inorganic carbon absorbing reagent. Volatile organic

components are oxidised in the volatile organic carbon combustion tube into carbon dioxide. The carbon dioxide concentration is converted in the same way as inorganic carbon and printed out.

Dry combustion-direct injection techniques using gas chromatography as the method of measurement have been devised for fresh water and low salinity water, but not for seawater. Nelson and Lysyj [109] used pyrolysis of the organic compounds without oxidation, with flame ionisation as the detection method. The technique was further developed by Eggertsen and Stross [105]. Since the response of this detector varies according to the type of organic compound present, the accuracy of the method cannot match its precision. This problem was overcome [110–113] by injecting the sample into a high-temperature furnace containing cupric oxide so that the organic components are oxidised to carbon dioxide, then reducing the carbon dioxide to methane, which is measured with a flame ionisation detector.

A more recent development is the Dohrmann DC-54 Ultra Low Level total organic carbon analysis. This equipment is capable of determining total organic carbon down to 10 µg/l, and purgeable organics down to 1 µg/l. It is applicable to seawater. The principle employed is ultraviolet-promoted chemical oxidation of organic carbon to carbon dioxide, followed by conversion to methane, which is determined by flame ionisation gas chromatography. Analysis time is 8–9 min, and the range of application 0–10 000 µg/l. The precision for total organic carbon is ±1 µg/l.

Preservation and Storage of Samples for the Determination of Dissolved Organic Carbon

As was expressed by Wangersky and Zika [96], sampling and storage of water samples for the determination of organic compounds can be an important source of errors. Duursma [34] stored his samples in 500 ml glass bottles, preserving with sulfuric acid. Wangersky and Zika [96] claim that addition of acid to samples can change organic compounds.

Merks and Vlasbom [114] filtered 20 ml sample through a glass fibre filter and then transferred the solution into a 20 ml glass ampoule. Immediately after that the ampoule was closed by heating it in a flame. The filters were pre-treated by heating at 330 °C, and the ampoules by heating at 610 °C, both for 2 h. After closing, the ampoules were deep frozen at –20 °C. Just before the determination of dissolved organic carbon the ampoule was thawed again and opened. Results of several compared analyses carried out by Olrichs [115] showed very good agreement using different analytical systems for measuring total organic carbon. However, Elgershuizen [116] did not find good agreement between determinations of dissolved organic carbon which were carried out in two laboratories. As the sampling took place at the same time and in the same way, the cause of the bad results can only be a matter of preservation and storage.

In fact, the conditions of storage were very different. Merks and Vlasbom [114] used glass ampoules stored at -20°C , whereas Elgershuizen [116] stored the samples in PVC bottles at 4°C , acidified to pH 2.

Merks and Vlasbom [114] carried out some comparative experiments on standard seawater with potassium hydrogen phthalate and water from Eastern Scheidt and Western Scheidt. These three types of samples were stored in three different ways and in three types of storage bottles.

The storage occurred in a deep-freezer at -20°C , in a refrigerator at 4°C and at room temperature at about 20°C in the laboratory. The bottles used in this investigation were glass ampoules, hard plastic bottles, and polystyrene sample cups as used in autoanalysers. The pretreatment of those bottles was as follows: the glass ampoules were heated at 610°C for 2 h, the plastic bottles were flushed several times with deionised water from a Millipore Milli-Q outfit and dried afterwards. The polystyrene cups were not pretreated at all. All samples were filtered over preheated glass fibre filters just before the three types of bottles were filled. Before filling with the sample, the plastic bottles and the polystyrene cups were rinsed twice with the filtered sample, while the glass ampoules were filled without rinsing.

From the results it can be concluded that the decrease in dissolved organic carbon with storage time is always lowest when the samples come deep frozen; deep freezing in a glass ampoule resulted in the lowest decline. Even under these conditions the storage time should be as low as possible.

Miscellaneous Methods for Measurement of Dissolved Organic Carbon

Methods that have been applied only to fresh water samples show some promise for seawater analysis. One such system [117] measures inorganic, volatile organic, and nonvolatile organic carbon fractions on the same sample. The different fractions are evolved separately, the inorganic carbon by acidification with phosphoric acid, the volatile fraction by purging with oxygen and high-temperature combustion of the vapours, and the nonvolatile fraction by ultraviolet photo-oxidation. In each case, the carbon dioxide evolved is purified by cold trapping.

Another technique depends upon the difference in rates of volatilisation to differentiate between organic and inorganic carbon, and upon plasma emission spectrography for the final measurement [118]. The sample is dispensed into a platinum boat, dried, and then covered with an oxidant, in this case V_2O_5 . The sample is then moved into an oven held at 850°C . At this temperature the organic carbon is volatilised a few seconds before the carbonate carbon. Light from a microwave-excited argon plasma, into which the volatile material is passed, is dispersed by a monochromator, and the 193 nm atomic carbon line is measured with a photomultiplier. An advantage of this technique is that oxidation to carbon dioxide need not be complete. When comparisons were run between this method and persulfate oxidation, no significant differences

were obtained. The obvious difficulty to be expected in using this technique for seawater analysis stems from the vastly greater concentration of carbonates. The peaks for organic and inorganic carbon are not completely separated. Even a small overlap between the peaks would prove disastrous.

Mills et al. [119] carried out reversed-phase liquid chromatographic studies of dissolved organic matter and copper-organic complexes isolated from estuarine waters.

The adsorption of organic matter on any surface presented to seawater has been well documented. Neihof and Loeb [120] have demonstrated this adsorbance by following the change in surface charge of newly immersed surfaces. There has even been an attempt to use this phenomenon as a means of measuring dissolved organic carbon. Chave [121] found an association between calcite and dissolved organic materials in seawater, and Meyers and Quinn [122] tried to use the effect as a method for the collection of fatty acids. As a collection technique, adsorption on calcite has several advantages. The pH of the sample is not greatly altered by the addition of small amounts of calcite; the precipitate is dense and should settle quickly; and after filtration the inorganic support can be removed by acidification. Unfortunately, the recovery of added fatty acids was inefficient – of the order of 18%. Meyers and Quinn [123] achieved a somewhat greater efficiency of collection of fatty acids with clays, but the insolubility of the clays nullified one of the advantages of this concentration technique.

Ferric hydroxide is the precipitant most commonly used for the collection of organics. It is formed by the in situ formation of hydrated ferric oxides, usually by the addition of ferrous iron, followed by potassium hydroxide. The technique was first used for the precipitation of organic matter from an aged algal culture [124]. They recovered 79–95% of the ^{14}C -labelled material from such cultures. Williams and Zirino [125], measuring efficiencies of removal of dissolved organic carbon, found that such scavenging collected between 38 and 43% of the organic carbon measurable by wet oxidation with persulfate. Chapman and Rae [126] examined the effect of this precipitation on specific compounds. They found coprecipitation to be more complete with copper hydroxides, but still far from satisfactory. Only certain compounds were removed effectively by this treatment, and the efficiency of removal varied with the water type and the organic compound involved.

11.7.2

Dissolved Inorganic Carbon

The strong increase in atmospheric concentrations of carbon dioxide [127] has generated considerable interest in the global carbon cycle [128–130]. Techniques for determining the components of the carbonate system have been refined, new techniques have been developed, or both. Among the four measurable parameters (total inorganic carbon), pH, pCO_2 , and total alkalinity

of the carbonate system, the total inorganic carbon has a typical range of 1900–2450 μM . TIC is routinely measured with high precision on semiautomated equipment by coulometry [131, 132], which is the generally accepted method for oceanographic research. Calibration is performed by standard procedures [133, 134] and certified reference materials as supplied by Dickson [134]. Other methods are determination via infrared detection following Sugimura and Suzuki [135] and Wiebinga [136], and by conductivity [137]. The former determines both total organic carbon by catalytic oxidation and total inorganic carbon by injection onto a low-temperature column, which does not oxidise any organic matter present. The latter does the same, albeit total inorganic carbon is determined via acidification of the sample. After diffusion across a silicone membrane in a dialyser, the increase in conductivity is determined, which is proportional to the amount of total inorganic carbon.

Biogeochemical processes, and especially their rates, modify the characteristics of the water column [138]. The introduction of underway measurements of carbonate system parameters in combination with temperature/salinity/fluorescence provided insight into the hitherto unexpected high variability and inherent deduced rates found in the surface ocean [139, 140]. These data also laid the foundation for a now quite extensive database used for modeling purposes as well as “ground truth” data for satellite observations (GOOS, Global Ocean Observing System; TOGA-COARE, Tropical Ocean Global Atmosphere-Coupled Ocean-Atmosphere Response Experiment). Though temperature and salinity gradients in the surface waters are resolved on a routine basis, resolving the spatial scale of chemical tracers in surface waters is typically limited either by the sample acquisition process (e.g., a station) or by the rate at which samples can be processed on board ship. Recent advancements have been made in shorter analysis times, but for total inorganic carbon via coulometry this has been only modest, as the electrochemical titration cannot be faster without losing its accuracy.

Hall and Aller [141] described another method based on flow injection analysis for determining total inorganic carbon and NH_4^+ in both marine waters and freshwaters. Standards for the total inorganic carbon analysis were prepared using sodium bicarbonate in distilled water. For a range of 0–2 mM (the latter being the upper limit in seawater), a RSD of 1.4% was found, which equals $\sim 28 \mu\text{M}$. A major advantage of their method was the speed at which samples could be analysed. A drawback, from an oceanographic point of view, is that the precision was less than required to resolve the fine details in the oceanic water column as needed for carbon budget.

Stoll et al. [142] have described a rapid continuous-flow determination of total inorganic carbon in seawater samples. The method runs on an autoanalyser Traacs 800 spectrophotometric system and is calibrated versus certified reference materials readily available. A typical analysis speed of 45 samples per hour can be reached with an accuracy of 2–3 μM and a precision of $\sim 2.5 \mu\text{M}$.

The analysis requires only a small amount of sample and is thus ideally suited for pore water samples and samples taken from cultures where sample volume is at a premium. The speed of the analysis makes mapping of oceanic surface water characteristics possible. Potential interference of sulfide in anoxic (e.g. pore water) samples can be masked by the addition of a hydrogen peroxide step. Although the latter is a strong oxidative reagent, no significant effect on total inorganic carbon concentration due to oxidation of (labile) organic matter could be found.

11.7.3

Particulate Organic Carbon

The simplest of the components of the organic carbon system to measure is the particulate phase, since the solid material can be isolated by filtration. Once the sampling conditions for filtration have been defined, the analytical procedures are straightforward. The major problem is that of sensitivity; depending upon the filter used, the particulate organic carbon content of surface seawater will run between 25 and 200 $\mu\text{g C}$ per litre, while the deep water will give values of 3–15 $\mu\text{g C}$ per litre. Almost without exception, the modern methods for particulate organic carbon use a high-temperature combustion of the filter and its organic load. Many early workers employed a wet oxidation with chromic and sulfuric acids, with the actual measurement being a titration with ferrous ammonium sulfate [143]. A rough conversion from wet oxidation to dry combustion values can be achieved by multiplication of the wet oxidation values by a factor of 1.09, commonly used for this purpose.

The various combustion methods differ primarily in the method of measuring the carbon dioxide generated from the organic carbon. The first really sensitive carbon dioxide detector and the one still most used is the non-dispersive infrared gas analyser. The detecting element senses the difference in absorption of infrared energy between a standard cell filled with a gas with no absorption in the infrared, and a sample cell. Water vapour is the only serious interference, hence the carbon dioxide must be dried before any measurements are made.

The carbon dioxide resulting from combustion of the particulate organic carbon can be passed through the analyser, producing a single spike on a recorder, or it can be pumped in a loop through the analyser, until an equilibrium concentration is reached in the loop. Since the output of the analyser is nonlinear, the latter technique has been favoured by some investigators [46].

Carbon analysers using the non-dispersive infrared analysers have been described by Kuck et al. [144] and by Ernst [145], among others.

Electrometric methods have also been used for the final measurement of carbon dioxide; Szekielda and Krey [146] devised a conductometric method. By far the most popular methods, however, have used commercial CHN analysers for the final measurement [147–150]. The actual measurement of carbon

dioxide with these instruments is made by gas chromatography; Perkin-Elmer supply a CHN analyser.

Of course, since these analysers measure all of the carbon dioxide generated, any carbonate present in the sample will also be measured as organic carbon. Many investigators remove any carbonate carbon by fuming the filters with hydrogen chloride vapour, or by treating them with dilute hydrochloric acid. Differential combustion has also been suggested as a method for distinguishing between carbonate carbon and organic carbon; baking at 500 °C for 4 h was used to remove organic carbon from carbonate-rich particulate matter [151].

An alternative method for the determination of particulate organic carbon in marine sediments is based on oxidation with potassium persulfate followed by measurement of carbon dioxide by a Carlo Erba non-dispersive infrared analyser [152, 153]. This procedure has been applied to estuarine and high-carbonate oceanic sediments, and results compared with those obtained by a high-temperature combustion method.

Weliky et al. [154] described a procedure for the determination of both organic and inorganic carbon in a single sample of a marine deposit. Carbonate carbon is determined from the carbon dioxide evolved by treatment of the sample with phosphoric acid; the residue is then treated with a concentrated solution of dichromate and sulfuric acid to release carbon dioxide from the organic matter. The carbon dioxide produced at the two stages of the analysis is estimated using a carbon analyser based on the thermal conductivity principle. In addition, total carbon content is determined on another subsample using the dry combustion furnace. This provides a check on the values determined by the phosphoric acid dichromate technique.

Salonen [155] compared different glass-fibre and silver-metal filters for the determination of particulate organic carbon. He puts forward a theory that the varying characteristics of different filters, or pore sizes, appreciably modify the results of particulate organic carbon determinations, making comparison of published concentrations unreliable. Salonen compares silver-metal filters and different types of glass-fibre filters, and seeks to find a filter which would have biologically meaningful cut-off size of particles. The most retentive glass-fibre filters were able to retain almost all bacteria from the water of an oligotrophic lake; they prove to be quite near to the ideal. Silver filters provide similar retention, but because of their high blank values, price, and lower filtration speed and capacity, they are not able to compete with glass-fibre filters in practical work.

11.7.4

Dissolved Organic Carbon

Many volatile organic compounds (hydrocarbons, alcohols, aldehydes, acids, esters, ketones, amines, etc.) have been identified in marine systems [156, 157]. These volatile materials may have an important role in the cycling of organic

matter in natural waters. Volatile or low molecular organic materials may be produced *in situ* by biological [158–161] and chemical reactions [162–164] or can be introduced into the marine systems by human activity [165, 166], or through fluvial and atmospheric transport.

Direct methods of analysis such as distillation [158, 167, 168], liquid–liquid extraction [159, 169], headspace analysis [170–172], dynamic headspace analysis [157, 173–178], and direct injection [179] have been used mainly for specific volatile components.

As for all of the fractions of organic material in seawater, the volatile organic carbon fraction is defined by the method by which it is collected. In one of the earliest estimates, Skopintsev [93] defined the volatile fraction as the difference between total organic carbon values, as measured by evaporation and dry combustion, when the evaporations were carried out at room temperature and at 60 °C. Thus Skopintsev's "volatile fraction" consists of those compounds that are volatile from acidified solution taken to dryness at 60 °C but not at 20 °C. This fraction was found to be between 10 and 15% of the total organic carbon. He also noted a 15% difference in measured organic carbon with his dry combustion method when samples were dried at different temperatures and concluded that this difference was due to the loss of volatiles.

The volatile fraction as defined by the various wet oxidation methods and most of the direct injection methods would be that fraction removed by acidification and purging with inert gas at room temperature. In the freeze-drying method of Gordon and Sutcliffe [29] the volatile fraction is that fraction lost by sublimation *in vacuo*. There have been no actual determinations of these losses, and for the most part Skopintsev's numbers were accepted as valid for all of these methods, largely because they are the only numbers available.

MacKinnon [91] and Wangersky [180] have made direct determinations of the volatile fractions from a variety of depths and stations in the North Atlantic. The volatile fraction as defined by MacKinnon's method is that fraction which can be removed from solution by purging with an inert gas at 80 °C and a pH of 8 for 10–12 hours, then at 65 °C for a further 10–12 hours. The inert gas stream is flushed through an ice-packed condenser to remove water, then into a trap packed with Tenax GC followed by a U-shaped stainless steel cold trap held at –78 °C.

Gershey et al. [58] have pointed out that persulfate and photo-oxidation procedures will determine only that portion of the volatile organics not lost during the removal of inorganic carbonate [30, 79, 92, 181]. Loss of the volatile fraction may be reduced by use of a modified decarbonation procedure such as one based on diffusion [98]. Dry combustion techniques that use freeze-drying or evaporation will result in the complete loss of the volatile fraction [72, 79, 92, 93].

The loss of volatile organics will only be a problem in areas where the volatile component is high. In open ocean areas volatiles should be a small fraction (2–6%) of the total organic carbon [91]. Under strongly reducing conditions,

many of the end-products of microbial metabolism are volatile in nature. Deuser [182] noted that his wet oxidation analysis of the dissolved organic carbon of water from the reducing part of the Black Sea gave systematically higher values than those of dry combustion. He concluded that it was due to substantial amounts of volatile material in the water produced as a consequence of anaerobic microbial metabolism.

In further work to that discussed above, MacKinnon [183] has discussed in detail a method for the measurement of the volatile fraction of total organic carbon in seawater.

In this method volatile organic matter in seawater is concentrated on a Tenax GC solid adsorbent trap and dry-ice trap in series. The trapped organic material is then desorbed and oxidised to carbon dioxide, which is measured with a non-dispersive infrared analyser. A dynamic headspace method was used for the extraction with the assistance of nitrogen purging. Dynamic headspace analysis [184] is an efficient extraction procedure. The efficiency of extraction

Table 11.3. Averaged volatile organic carbon (VOC) concentrations and VOC:total organic carbon (VOC:TOC) ratios from different areas [92]

Area (time of sampling)	Depth	<i>n</i>	Average VOC concentrations ($\mu\text{g C/l}$)	Range ($\mu\text{g C/l}$)	Average VOC:TOC ratio (%)	Range (%)
Gulf of St. Lawrence (11/75)	0–10	9	31.8 ± 8.4	21.7–51.7	2.7 ± 0.9	1.9–4.8
	10–50	6	36.0 ± 8.9	22.3–47.0	3.0 ± 0.6	2.0–3.7
	50–100	5	29.8 ± 1.7	27.5–32.2	2.7 ± 0.4	2.2–3.1
	100–250	9	30.1 ± 6.5	22.8–38.8	3.1 ± 0.7	2.2–4.1
Scotian shelf & slope (5/74) (8/75) (3/76)	0–10	26	40.9 ± 9.1	23.9–60.6	3.3 ± 0.9	1.8–5.9
	10–25	16	37.8 ± 8.1	24.0–53.0	3.4 ± 0.8	1.9–5.2
	25–100	17	33.9 ± 9.9	24.0–68.5	3.5 ± 0.9	1.8–6.2
	100–250	17	35.5 ± 3.7	28.3–41.2	4.1 ± 0.5	3.5–4.9
	250–750	12	33.0 ± 6.4	22.4–46.4	4.5 ± 0.9	3.0–6.1
	750–1500	5	26.2 ± 2.4	23.2–29.7	3.7 ± 0.3	3.4–4.0
Central & northwestern Atlantic (10/74) (2/75)	0–10	31	30.4 ± 9.7	17.6–52.4	3.1 ± 1.1	1.7–5.5
	10–25	14	27.8 ± 6.2	18.8–36.7	2.8 ± 0.7	1.7–3.2
	25–100	15	31.9 ± 9.8	22.6–52.2	3.4 ± 1.1	2.3–5.8
	100–250	35	27.7 ± 6.5	17.0–52.3	3.3 ± 0.9	2.0–5.8
	250–750	22	25.1 ± 4.4	19.6–34.0	3.5 ± 0.7	2.5–5.1
	750–1500	15	26.1 ± 4.6	20.2–34.7	3.6 ± 0.7	2.7–4.7
	1500–3000	15	24.4 ± 2.5	19.2–29.3	3.4 ± 0.4	2.5–4.3
3000–5000	5	26.5 ± 1.7	25.0–29.1	3.8 ± 0.5	3.4–4.7	
Northwest arm Halifax Harbour (4/76)	0–10	37	32.6 ± 7.8	20.4–49.4	1.9 ± 0.4	1.2–2.9
St. Margaret's Bay, Nova Scotia (4/76)	0–40	28	30.9 ± 6.2	19.8–45.5	2.3 ± 0.5	1.4–3.4

can be increased by using a purging gas and increasing the temperature of the sample to 60–80 °C [173]. The efficiency and properties of Tenax GC have been examined [177, 185–187].

The efficiency of extraction and analysis was determined for different classes of volatile organic materials. Acetone was used as a test material to evaluate efficiency for the extraction, concentration, and analysis procedures. While acetone has a high vapour pressure, it is difficult to extract efficiently from water because of its high solubility. Almost complete recovery of acetone from seawater was obtained. Over the concentration range 10–200 µg C per litre, high recoveries (100±20%) of acetone added to pre-extracted seawater samples were calculated. For other compounds tested, high recoveries were noted for materials of low solubility and high vapour pressure (hydrocarbons, ethers, esters, aldehydes, ketones, nitriles), while poorer recoveries were observed for the more polar organic compounds (alcohols, amines, acids).

Table 11.3 presents some typical results obtained by this procedure on seawater samples. MacKinnon [92] concluded that since the volatile organic carbon contents of normal (i.e., unpolluted) seawaters are small, the effect of complete or partial loss of volatile organic components during the determination of total organic carbon in most ocean areas (except highly reducing environments) with either the wet and direct injection methods or dry oxidation methods should be small (about 5%), and within the precision of these methods.

11.7.5 Chemical Oxygen Demand

The chemical method for the determination of the chemical oxygen demand of non-saline waters involves oxidation of the organic matter with an excess of standard acidic potassium dichromate in the presence of silver sulfate catalyst followed by estimation of unused dichromate by titration with ferrous ammonium sulfate. Unfortunately, in this method, the high concentrations of sodium chloride present in sea water react with potassium dichromate producing chlorine:

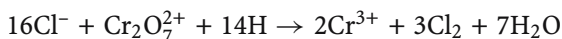

Consequently the consumption of dichromate is many times higher than that due to organic material in the sample. To complicate matters, any amines in the sample consume and release chlorine in a cyclic process, leading to high chemical oxygen demands.

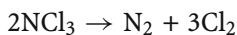
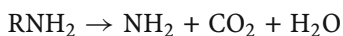

Also, the addition of silver sulfate causes precipitation of silver chloride, which in the presence of organic compounds is neither completely nor reproducibly oxidised. This method, whilst being applicable to estuarine waters of relatively low chloride content, would present difficulties when applied to highly saline estuarine and sea waters of low organic content.

This method, whilst being applicable to estuarine waters of relatively low chloride content, would present difficulties when applied to highly saline seawaters of low organic content. Zeitz [188] gives details of a method for the determination of chemical and oxygen demand, by potassium dichromate. Its advantages over previously published methods are that greater accuracy is achieved in recording even very small chemical oxygen demand measurements when there is a high chloride concentration, and the use of mercury compounds as buffering agents is obviated. It is claimed that the process must be carried out in a closed vacuum flask. The concentration of chlorine in the gaseous phase is so slight that it can be disregarded when chemical oxygen demand values are being determined.

Wagner and Ruck [189, 190] propose various methods for overcoming interference by chloride in the determination of chemical oxygen demand. These include the quantitative oxidation of chloride ions to chlorine and a corresponding correction of the result of the chemical oxygen demand determination; use of mercuric sulfate as a sequestering agent for chloride ions, for which the limits of validity are discussed; and elimination of chloride ions prior to the oxidation step by conversion to hydrogen chloride and its diffusion into a closed chamber to reduce losses of volatile constituents.

Because of the invalidity of the classical procedure, several workers have attempted to devise a method that is free from interference by chloride. Chloride interference can be eliminated by preventing the concurrent oxidation of organic material and chloride. This can be effected in two ways – either by leaving the chloride in the test mixture but preventing its oxidation, or by removing the chloride prior to the chemical oxygen demand test.

Both ways have been used in previously reported attempts to remove chloride interference. Three methods have been used in attempts to prevent chloride oxidation: masking with mercury (II) [191, 192]; precipitation of chloride using silver (I) [188]; or altering oxidation conditions [193].

Two methods have been used for removal of chloride, the chloride being removed as chlorine [194, 195] or as hydrogen chloride [196].

Baumann [197] collected the chlorine produced in the reaction in excess potassium iodide solution and back titrated against standard sodium thiosulfate to obtain the necessary correction for chloride.

Wagner and Ruck [190] carried out experiments to test the reliability of two standard procedures (DIN 38409 Parts 41/2 and 42) for the removal of chloride ions prior to chemical oxygen demand determinations on chloride-

containing samples. Acetic acid was used as a model substance on account of its volatility, and the use of special absorbers for hydrochloric acid vapour generated by the addition of sulfuric acid was tested under various conditions. In no case was there any appreciable loss of acetic acid, but in some cases a yellow coloration was observed in the solution coupled with an increase in the measured chemical oxygen demand value. This was traced to the presence of nitrate ions which were reduced to nitrite ions by chloride in acid solution, the resulting nitrite ions being reoxidised during the subsequent stages and hence contributing to an inflated value for the chemical oxygen demand. As a preventive measure in the case of samples containing nitrate ions the hydrogen chloride diffusion can be carried out using weaker sulfuric acid solutions and, if necessary, using a longer reaction time in the analysis.

Southway and Bark [198] reported their findings on their investigations into three processes for removing chloride from the test solution and suggested that the method (3) may be of some value:

1. Removal by precipitation as silver chloride with subsequent filtration, so that a negligible amount of organic matter is coprecipitated with the silver chloride.
2. Removal as chlorine in an oxidation stage, mild enough to prevent any significant oxidation of easily oxidised organic matter.
3. Removal by a ligand exchange process using the silver I or the mercury II form of poly vinyl pyridine [199].

Lloyd [200] has given details of a method for determining the chemical oxygen demand of saline samples which uses digestion of the sample at 150 °C in a glass stoppered flask with silver nitrate to suppress interference by chloride. Within-batch relative standard deviation ranged from 2.2% at levels of 60 mg/l of chemical oxygen demand to 0.8% at 380 mg/l of chemical oxygen demand (4 degrees of freedom). Total relative standard deviation in analysis of a 300 mg/l chemical oxygen demand potassium hydrogen phthalate solution was 1.0% (8 degrees of freedom) These did not differ significantly ($p = 0.5$) from data obtained using the standard procedure or the silver nitrate reflux chemical oxygen demand procedure.

Standard solutions of potassium hydrogen phthalate, spiked with chloride, were also analysed. These results are compared with those given for the standard procedure in Table 11.4.

Thompson et al. [201] have described a simple method for minimising, but not eliminating, the effect of chloride on the determination of chemical oxygen demand without the use of mercury salts. This method minimised interference from the potassium dichromate oxidation of chloride to chlorine by adding a small amount of chromium (III) to the sample digest prior to heating. Chromium (III) was thought to complex any free chloride ion in the sample solution. The method was particularly useful at low chemical oxygen

Table 11.4. Analyses of chloride-spiked potassium hydrogen phthalate solutions by standard and sealed-tube procedures (1 ml 25% m/v silver nitrate solution) [200]

Expected COD (mg/l)	Observed COD at given chloride level (mg/l Cl)				
	0	500	1000	1500	2000
0	–	15 (10)	19 (23)	21 (41)	32 (59)
100	102	112 (103)	115 (209)	121 (109)	128 (121)
200	199	203 (206)	209 (214)	221 (215)	217 (228)
300	295	300 (308)	297 (308)	311 (311)	316 (318)
400	391	401 (404)	403 (404)	405 (412)	407 (419)

Results are the means of two determinations. Values in parentheses are means of results obtained using the standard sealed-tube procedure.

demand concentrations, chloride effects significantly decreasing with increases in chemical oxygen demand.

In the author's experience, no truly satisfactory method yet exists for the determination of chemical oxidation demand in highly saline samples such as seawater. With reservations, several of the above methods are, however, applicable to estuarine waters of low salinity.

11.7.6

Biochemical Demand

It has been reported that whilst the dilution bottle method for biochemical oxygen demand yields satisfactory results on fresh and low saline waters, a discrepancy exists when the test is performed on waters containing elevated levels of sodium chloride and other salts.

Kessick and Manchen [202], using a manometric BOD apparatus, found that the soluble waste portion in a salt water carrier was metabolised at the same rate by the microbial population in domestic sewage. However, the insoluble portion produced different rates, with that of domestic sewage in fresh water being three times greater than that of domestic sewage in a salt water carrier. Manchen [203] reported that only the degradation of suspended organic material was inhibited by salt and that the dissolved organic fraction of the BOD was unaffected. Davis et al. [204], using hypersaline industrial wastes with salt tolerant bacteria species as seed, found that the BOD varied according to the salt concentrations. Increases in BOD resulted when the salt level was decreased. Ten-day BODs on salt water wastes were 3–6 times higher with standard dilution water than with a dilution water having the same salinity as the waste.

The rate of biological oxidation may vary considerably under different test conditions. Gotaas [205] reported that waste waters containing less than 10 000 mg/l chloride diluted with fresh water had a rate of biological oxidation

value greater than that of fresh water waste. The rate of biological oxidation increased to the point equivalent to 50% of that of seawater. When the 50% level was exceeded, the rate of biological oxidation decreased, until in 100% seawater, it was lower than in fresh water. This led to the hypothesis that a low salinity may stimulate microbial activity and result in increased BOD values. Seymour [206] also found that an increase in salinity resulted in a decrease of BOD values. Degradation rate decreased as the salinity level increased, yet only the particulate fraction seemed to be affected. Degradation of the soluble portion was not affected as adversely by salt content.

Lysis of bacteria will occur in a growth medium when sodium chloride is added. It will also occur when salt-acclimated bacteria are placed in fresh water. If the change in salt concentration is less than 10 000 mg/l the degree of lysis is negligible, but if greater the lysis can be extensive. Cellular constituents released following lysis are metabolised by the remaining microbial population in preference to the substrate present, thus yielding erratic results [207, 208].

Davies et al. [209] set out to quantify the effects of fresh and saline dilution waters on the BOD of salt water wastes and to quantitatively establish the role of bacterial seed numbers and species associated with changes in BOD results. Sewage bacteria and salt-tolerant bacteria were evaluated to determine their capability to produce the same BOD values at various salt concentrations. When variations occurred in the BOD values, Davies et al. [209] attempted to identify the reasons for such variations. They employed conventional and manometric BOD methods. Standard organic solutions and an industrial waste were tested with sewage seed and known species of salt-tolerant bacteria using standard and hypersaline dilution water at three salt concentrations. Significant BOD differences were found when saline wastes were diluted with standard (non-saline) BOD dilution water. Bacterial populations to genera were monitored and it was shown that equivalent numbers of bacteria did not have the same capability to degrade a given amount of waste with increases in salt concentrations to the 3% level. Seeding of hypersaline waste waters with known salt-tolerant species is recommended for consistent BOD results.

The BOD values obtained in sewage seed organic standards showed a significant trend: as salt concentration increased, BOD values decreased. Changes were significant at the 0.05 level. Dilution of sewage-seeded saline organic standards with standard dilution water resulted in BOD values higher than those of corresponding non-saline organic standards, due to increases in bacteria populations and increased organic removal (BOD values) in the presence of low levels of salt. Bacteria populations of sewage seed correlated with corresponding BOD values and concentrations of salt in organic standard solutions showed that the addition of 1% and 3% salt resulted in decreased initial bacteria population, decreased growth rates, and a decreased ability of an equivalent number of bacteria to degrade an equivalent amount of organic material.

Each salt-tolerant bacteria species yielded comparable BOD values for each organic standard conducted at three salt concentrations. Population increased and the rates of biological oxidation were similar at the three salt concentrations and when using either the standard dilution water or the saline dilution water.

Since sewage seed does not compare favourably with salt-tolerant bacteria in determining the BOD of saline waste waters, a salt-tolerant bacteria seed should be used to ensure an accurate and reproducible BOD value hypersaline waste waters are being tested.

11.8

Oxygen Isotopic Ratios

Baker et al. [210] described a technique for the determination of $^{18}\text{O}/^{16}\text{O}$ and $^{17}\text{O}/^{16}\text{O}$ isotopic ratios in liquid samples.

References

1. Ball JW, Thompson JM, Jenne EA (1978) *Anal Chim Acta* **98**:67
2. Chen L, Lin J, Yu J, Wu S (1993) *Haiyang Xuebao (Zhongwenban)* **15**:142
3. Nishioka H, Sai N, Kumagai T, Nagahiro T, Uesugi K (1992) *Nippon Kaisui Gakkaishi* **46**:391
4. Schnepfe MM (1972) *Anal Chim Acta* **58**:83
5. Sugawara D (1956) *Anal Abst* **93**:1169
6. Matthews AD, Riley JP (1970) *Anal Chim Acta* **51**:295
7. Tsunogai S (1971) *Anal Chim Acta* **55**:444
8. Kesari R, Rastogi A, Gupta VK (1998) *Chem Anal (Warsaw)* **43**:201
9. Astrani U (1973) Analysis of waters for nitrogen. PB report no. 238056/6GA. National Technical Information Service, Springfield, VA, USA
10. Yablokava OG (1974) *Okeanologiya* **14**:1113
11. Mertens J, Van Den Winkel P, Massart DL (1975) *Int J Environ Anal Chem* **47**:25
12. Stevens RJ (1976) *Water Res* **10**:171
13. Adamski JM (1976) *Anal Chem* **48**:1194
14. D'Elia CF, Steudler PA, Corwin N (1977) *Limnol Oceanogr* **22**:760
15. Armstrong FAJ, Williams PM, Strickland JDH (1966) *Nature* **211**:481
16. Tenny AM (1966) *Automated Anal Chem* **38**:580
17. Manny BA, Miller MC, Wetzel RG (1971) *Limnol Oceanogr* **16**:71
18. Bruegmann L, Wilde A (1975) *Acta Hydroch Hydrob* **3**:203
19. Holm-Hansen O, Strickland JDH, Williams PM (1966) *Limnol Oceanogr* **11**:548
20. Butler EI (1979) *Estuar Coast Mar Sci* **8**:195
21. Butler E, Knox S, Liddicoat MI (1979) *J Mar Bio Assoc UK* **59**:239
22. Strickland JDH, Parsons TR (1972) A practical handbook of seawater analysis. Bulletin 167. Fisheries Research Board, Canada, p 310
23. Armstrong FAJ, Tibbitts S (1968) *J Mar Bio Assoc UK* **48**:143
24. Koroleff F (1969) Determination of total nitrogen in natural waters by means of digestion. International Council for the Exploration of the Sea, Hydrography Committee, CM/C:8, p 4
25. Koroleff F (1976) In: Grasshoff K (ed), *Methods of seawater analysis*. Verlag Chemie, New York, p 116

26. Shepherd RJ, Davies IM (1981) *Anal Chim Acta* **130**:55
27. D'Elia CF, Stendler PA, Corwin N (1977) *Limnol Oceanogr* **22**:760
28. Nydahl F (1978) *Water Res* **12**:1123
29. Gordon DC Jr, Sutcliffe WH Jr (1973) *Mar Chem* **1**:231
30. Collins KJ, Williams PJ, Le B (1977) *Mar Chem* **5**:123
31. Suzuki A, Satoh M, Kamiya M, Ogawa S (1985) *Mizushori Gijutsu* **26**:921
32. Nakamura E, Namiki H (1987) *Kogyo Yosui* **34**:112
33. Frankovitch TA, Jones RD (1998) *Mar Chem* **60**:227
34. Duursma EK (1960) *Neth J Mar Res* **1**:148
35. Harvey HW (1948) *J Mar Bio Assoc* **27**:337
36. Armstrong FAJ, Tibbitts S (1968) *J Mar Bio Assoc* **48**:143
37. Grasshoff K (1966) *Fresen Z Anal Chem* **220**:89
38. Bikbulatov EW (1974) *Gidrokhim Mater* **60**:174
39. Mueller H, Bandaranayake WM (1983) *Mar Chem* **12**:59
40. Cembella AD, Antia NJ, Taylor FJP (1986) *Water Res* **20**:1197
41. Ormaza-Gonzales FI, Staham PJ (1996) *Water Res* **30**:2739
42. Abe K, Wanatabe Y (1992) *J Oceanogr* **48**:283
43. Taylor DL, Zeitlin H (1973) *Anal Chim Acta* **64**:139
44. Wangersky PJ (1975) Measurement of organic carbon in seawater. In: *Analytical Methods in Oceanography* (ed Gibb TRP) American Chemical Society Washington DC, p 148–162
45. Ogawa H (1993) *Shigen Kankyo* **2**:13
46. Menzel DW, Vaccaro RF (1964) *Limnol Oceanogr* **9**:138
47. Strickland JDH, Parsons TR (1968) *Bulletin Fisheries Research Board of Canada*, pp 167–311
48. Sharp JH (1973) *Mar Chem* **1**:211
49. Skopintsev BA (1960) *Marine Hydrophysics Institute* **19**:1
50. Takahashi Y (1976) Ultra low level TOC analysis of potable waters. Presented at the water quality technology conference. American Water Works Association, San Diego, CA, USA
51. Van Hall CE, Safranko J, Stenger H (1963) *Anal Chem* **35**:315
52. Axt G (1969) *Vom Wasser* **36**:328
53. Solomen K (1979) *Limnol Oceanogr* **24**:177
54. Glor R, Leidner H (1979) *Anal Chem* **51**:645
55. Beattie J, Bricker C, Garvin D (1961) *Anal Chem* **33**:1890
56. Woelfel P, Sontheimer H (1974) *Vom Wasser* **43**:315
57. Ehrhardt M (1969) *Deep-Sea Res* **16**:393
58. Gershay RM, MacKinnon MD, Williams PJ, Le B, Moore RM (1979) *Mar Chem* **7**:289
59. Wangersky PJ (1981) *Trends Anal Chem* **1**:28
60. Armstrong FAJ, Boalch GT (1961) *J Mar Bio Assoc* **41**:591
61. Bauer D, Brun-Cottan JC, Saliot A (1971) *Canadian Oceanography* **23**:841
62. Hanya T, Ogura N (1964) Columbo U, Hobson GD (eds) Application of ultraviolet spectroscopy to the examination of dissolved organic substances in water. In: *Advances in organic geochemistry*. Pergamon Press, Oxford, pp 1–10
63. Ogura N, Hanya T (1966) *Nature* **212**:758
64. Ogura N, Hanya T (1967) *Limnol Oceanogr* **1**:91
65. Lewis WM Jr, Tyburczy JA (1974) *Archives of Hydrobiology* **74**:8
66. Mattson JS, Smith CA, Jones TT, Gerchakov SM (1974) *Limnol Oceanogr* **19**:530
67. Wheeler JR (1977) *Limnol Oceanogr* **22**:573
68. Kulkarni RN (1975) *Water Air Soil Poll* **5**:231

69. Biggs R, Schofield JW, Gorton PAJ (1976) *Water Pollut Cont Fed* 47:2
70. Maciolek JA (1962) USF and WS Research Report 60:1
71. Camps JM, Arias E (1963) *Invest Pesq* 23:125
72. Oppenheimer CH, Corcoran EF, Van Arman J (1963) *Limnol Oceanogr* 8:487
73. Krey J, Szeikielda KH (1965) *Fresen Z Anal Chem* 207:338
74. Duursma EK (1960) *Netherlands J Mar Res* 1:1
75. Williams PJ, Le B (1969) *Limnol Oceanogr* 14:292
76. Boehme H (1975) *Acta Hydroch Hydrobiol* 3:327
77. Baldwin JM, McAtee RE (1974) *Microchem J* 19:179
78. Goulden PD, Brooksbank P (1975) *Anal Chem* 47:1943
79. Wilson RF (1961) *Limnol Oceanogr* 6:259
80. Martinie GC, Schilt AA (1976) *Anal Chem* 48:70
81. Williams PH (1969) *Limnol Oceanogr* 14:297
82. Hannaker P, Buchanan SS (1983) *Anal Chem* 55:1922
83. Gordon MA (1914) *J Phys Chem* 18:55
84. Williams PH (1969) *Anal Abst* 17:3613
85. Woelfel P, Schuster W, Sontheimer H (1975) *Z Wass Abwass Fors* 8:143
86. Schreurs W (1978) *Hydrobiol Bull* 12:137
87. House DA (1962) *Chem Rev* 62:188
88. Moore RM (1977) Trace metals dissolved organic matter and their association in natural waters. PhD Dissertation. University of Southampton
89. Montgomery HAC, Thorn NS (1962) *Analyst* 87:687
90. Skopintsev BA, Timofeyeva SN (1962) *Marine Hydrophysics Institute* 25:110
91. MacKinnon MD (1977) The analysis of total organic carbon in seawater. (a) Development of methods for the quantification of TOC. (b) Measurement and examination of the volatile fraction of the TOC. PhD Dissertation. Dalhousie University
92. MacKinnon MD (1978) *Mar Chem* 7:17
93. Skopintsev BA (1966) *Oceanography* 6:361
94. Williams PJ, Le B (1975) Determination of organic components. In: Riley JP, Skirrow G (eds) *Chemical oceanography*, vol. 3. Academic Press, New York, pp 443–477
95. Skopintsev BA (1976) *Oceanology* 16:630
96. Wangersky PJ, Zika RG (1978) The analysis of organic compounds in seawater. Report 3, NRCC 16566, Marine Analytical Chemistry Standards Program
97. Van Hall CE, Stenger VA (1964) *Water Sewage* 111:266
98. Van Hall CE, Barth D, Stenger VA (1965) *Anal Chem* 37:769
99. Van Hall CE, Stenger VA (1967) *Anal Chem* 39:503
100. Van Hall CE, Safranko J, Stenger VA (1963) *Anal Chem* 35:319
101. Golterman HL (1969) *Methods for chemical analysis of freshwater*. Blackwell, Oxford, pp 133–145
102. Water Pollution Research Laboratory (1972) Notes on water pollution, no. 59. HMSO, London
103. Salvatella Battlori N, Ribas Soler F, Oromi Durich J (1974) *Doc Invest Hidrol* 17:303
104. Stenger V, Van Hall CE (1969) *Anal Chem* 39:206
105. Eggertsen FT, Stross FH (1972) *Anal Chem* 44:709
106. Bartz AM (1968) *SPE Transactions* 7:279
107. Hiser LL, Tarazi DS, Boldt CA, Saenz O (1970) *Am Lab* 2:44
108. Ton N, Takahashi Y (1985) *Int Lab* September:49
109. Nelson KH, Lysyj I (1968) *Environ Sci Tech* 2:61
110. Dobbs RA, Wise RH, Dean RB (1967) *Anal Chem* 39:1255
111. Cropper FR, Heinekey DM, Westwell A (1967) *Analyst* 92:436

112. Cropper FR, Heinekey DM, Westwell A (1967) *Analyst* **92**:443
113. Croll BT (1972) *Chem Ind London* 386
114. Merks AGA, Vlasbom AG (1983) *Hydrobiol Bull* **17**:53
115. Orlachs SHS (1982) *Projektur* **71**:211
116. Elgershuizen JHBW (1981) Meitingen von DOC Gehahen, Notitie, DDMI 81-278
117. Games LM, Hayes JM (1976) *Anal Chem* **48**:130
118. Mitchell DG, Aldous KM, Canelli E (1977) *Anal Chem* **49**:1235
119. Mills GL, McFadden E, Quinn JG (1987) *Mar Chem* **20**:313
120. Neihof R, Loeb G (1974) *J Mar Res* **32**:5
121. Chave KE (1965) *Science* **148**:1723
122. Meyers PA, Quinn JG (1971) *Limnol Oceanogr* **16**:992
123. Meyers PA, Quinn JG (1973) *Geochim Cosmochim Acta* **37**:1745
124. Jeffrey LM, Hood DW (1958) *J Mar Res* **17**:247
125. Williams PM, Zirino A (1964) *Nature* **204**:462
126. Chapman G, Rae AC (1967) *Nature* **214**:627
127. Keeling CD, Whorf TP (1994) *ORNL/CDIAC* **65**:16
128. Sarmiento JL (1993) *Nature* **365**:697
129. Tans PP, Fung IY, Takahashi T (1990) *Science* **247**:1431
130. Sarmiento JL, Orr JC, Siegenthaler UL (1992) *J Geophys Res* **C97**:3621
131. Johnson KM, Williams PJ, Le B, Brandstrom L, Sieburth JM (1987) *Mar Chem* **21**:117
132. Johnson KM, Wills KD, Butler DB, Johnson WK, Wong CS (1993) *Mar Chem* **44**:167
133. Goyet C, Hacker SD (1992) *Mar Chem* **38**:37
134. DOE (1994) Dickson AG, Goyet C (eds) *ORNL/CDIAC* 74
135. Sugimura Y, Suzuki Y (1988) *Mar Chem* **24**:105
136. Wiebinga CJW (1999) PhD Dissertation. University of Groningen
137. Godec R, O'Neill K, Hutte R (1984) *Ultrapure Water* 17
138. Bakker DCE, de Baar HJW, Bathmann U (1997) *Deep-Sea Res* **44**:91
139. Takahashi T, Olafsson J, Goddard JG, Chipman DW, Sutherland SC (1993) *Global Biogeochem Cy* **7**:843
140. Hoppema MJJ, Fahrbach E, Schröder M, Wisotzki A, de Baar HJW (1995) *Mar Chem* **51**:177
141. Hall POJ, Aller RC (1992) *Limnol Oceanogr* **37**:1113
142. Stoll MHC, Bakker K, Nobbe GH, Haese RR (2001) *Anal Chem* **73**:4111
143. Fox D, Isaacs JD, Corcoran EF (1952) *J Mar Res* **11**:29
144. Kuck JA, Berry JW, Andreatch AJ, Lentz PA (1962) *Anal Chem* **34**:403
145. Ernst W (1975) *Inst Meeresforsch Bremerh* **15**:269
146. Szekiolda KH, Krey J (1965) *Mikrochim Acta* 149
147. Hagell GT, Pocklington R (1973) A seagoing system for the measurement of particulate carbon, hydrogen and nitrogen. Report Ser./BI-R-73-14, 1-18
148. Telek G, Marshall N (1974) *Mar Biol* **24**:219
149. Ehrhardt M (1976) Determination of particulate organic carbon and nitrogen. In: Grasshoff K (ed) *Methods of seawater analysis*. Verlag Chemie, New York, pp 215-220
150. Ehrhardt M (1976) The automatic determination of dissolved organic carbon. In: Grasshoff K (ed) *Methods of seawater analysis*. Verlag Chemie, New York, pp 289-297
151. Hirota J, Szyper JP (1975) *Limnol Oceanogr* **20**:896
152. Mills JG, Quinn GL (1979) *Chemical Geology* **25**:155
153. Kerr RA (1977) The isolation and partial characterization of dissolved organic matter in seawater. PhD Dissertation. University of Rhode Island
154. Weliky K, Suess E, Ungerer CA, Muller PJ, Fischer K (1983) *Limnol Oceanogr* **28**:1252
155. Salonen K (1979) *Hydrobiologia* **67**:29

156. Giger W (1977) *Mar Chem* 5:429
157. Schwarzenbach RP, Bromond RH, Gschwend PM, Zafiriou OC (1978) *Org Geochem* 1:93
158. Armstrong FA, Boalch GT (1960) *Nature* 185:761
159. Koyama T (1962) *Journal of the Oceanographic Society of Japan* 20:563
160. Lovelock JE, Maggs RJ, Rasmussen RA (1972) *Nature* 237:452
161. Wangersky PJ (1976) *Deep-Sea Res* 23:457
162. Wilson DF, Swinnerton JW, Lamontagne RA (1970) *Science* 168:1577
163. Dowty BL, Green LE, Lasteter JL (1976) *Anal Chem* 46:946
164. Zika RG (1977) An investigation in marine photochemistry. PhD Dissertation. Dalhousie University
165. Goldberg ED (1971) Atmosphere transport. In: Hoo DW (ed) *Impingement of man on the oceans*. Wiley-Interscience, New York, pp 75–88
166. Swinnerton JW, Lamontagne RA (1971) *Environ Sci Tech* 8:657
167. Lamar WL, Goerlitz DF (1966) Organic acids in naturally colored surface waters. Geological Survey Water Supply Paper 1817-A
168. Ryabov AK, Nabivanets BI, Litvinenko SZ (1972) *Hydrobiological Journal* 8:97
169. Kamata E (1966) *Bulletin of the Chemical Society of Japan* 39:1227
170. Bassette R, Ward G (1969) *Microchem J* 14:471
171. Corwin JF (1970) Volatile organic matter in seawater. In: Hood DW (ed) *Organic matter in natural waters*, vol. 1. University of Alaska Press, pp 169–180
172. Hurst RE (1974) *Analyst* 99:302
173. Mieure JP, Dietrich MW (1973) *J Chromatogr Sci* 11:559
174. Novak J, Zluticky J, Kubelka V, Mostecky J (1973) *J Chromatogr* 76:45
175. Grob K (1973) *J Chromatogr* 84:255
176. Zurcher F, Giger W (1976) *Vom Wasser* 47:37
177. Kuo PRK, Chian ESK, DeWalle FB, Kim JH (1977) *Anal Chem* 49:1023
178. Sauer TC Jr, Sackett WM, Jeffrey LM (1978) *Mar Chem* 7:1
179. Harris LE, Budde WL, Eichelberger JW (1974) *Anal Chem* 46:1912
180. Wangersky PJ (1978) Production of dissolved organic matter. In: Kinne O (ed) *Marine ecology*, vol. 4. Wiley, New York
181. Duursma EK (1961) *J Sea Res* 1:1
182. Deuser WS (1971) *Deep-Sea Res* 18:995
183. MacKinnon MD (1979) *Mar Chem* 8:143
184. Grob K, Grob K Jr, Grob G (1975) *J Chromatogr* 106:299
185. Zlatkis A, Lichtenstein HA, Tichbee A (1973) *Chromatographia* 6:67
186. Russell JW (1975) *Environ Sci Tech* 9:1175
187. Daemen JM, Dankelman HW, Hendriks ME (1975) *J Chromatogr Sci* 13:79
188. Zeitz U (1976) *Gas-u-Wassertach (Wasser Abwasser)* 117:181
189. Wagner R, Ruck W (1981) *Z Wasser Abwass For* 14:145
190. Wagner R, Ruck W (1982) *Z Wasser Abwass For* 15:287
191. Dobbs RA, Williams RT (1963) *Anal Chem* 35:1064
192. Cripps JM, Jenkins D (1964) *Journal of the Water Pollut Cont Fed* 36:1240
193. Ryding SO, Forsberg A (1977) *Water Res* 11:801
194. Cameron WM, Moore TB (1957) *Analyst* 82:677
195. Hoffmann HJ (1979) *Labor Prax (Warsberg)* 3:38
196. Frankland E, Armstrong HE (1868) *Journal of the Chemical Society* 21:77
197. Baumann FJ (1974) *Anal Chem* 46:1336
198. Southway C, Bark LS (1981) *Anal Proc* 18:7
199. Heinerich F (1961) *Nature* 189:1001

200. Lloyd A (1982) *Analyst* **107**:1316
201. Thompson KC, Mendham D, Best D, De Casseres KE (1986) *Analyst* **111**:483
202. Kessick MA, Manchen KL (1976) *Journal of the Water Pollut Cont Fed* **48**:2131
203. Manchen LK (1974) Unpublished dissertation, Rice University
204. Davis EM, Petros JK, Powers EL (1977) *Industrial Wastes* **23**:22
205. Gotaas HB (1949) *Sewage Works J* **21**:818
206. Seymour MP (1977) The biodegradation of particulate organic matter in saltwater media. Dissertation, Rice University
207. Kincannon DF, Gaudy AF (1966) *Biotechnical Engineering* **8**:371
208. Kincannon DF, Gaudy A (1966) *Journal of the Water Pollut Cont Fed* **38**:1148
209. Davies EM, Bishop JR, Guthrie RK, Forthofer R (1978) *Water Res* **12**:917
210. Baker L, Franchi IA, Maynard J, Wright IP, Pillinger CT (2002) *Anal Chem* **74**:1165

Subject Index

- acetate, determination of 39
- acidity, determination of 21
- acrylamide, determination of 400, 401
- acrylate, determination of 39
- actinium, determination of 112
- adsorption techniques 354
- aldehydes, determination of 380, 381
- aliphatic chloro-compounds, determination of 390–392
- aliphatic hydrocarbons, determination of 366–368
- alkalinity
 - determination 39–41
 - preservation 21
- alkyl lauryl sulfide, determination of 401
- aluminium
 - determination of 112–114, 247, 271, 322
 - sampling 2
- americium, determination of 336
- amines, determination of 398
- ammonium
 - determination of 114–118, 313
 - preservation 21
- amperometry, determination of anions 103–108
- anions, pre-concentration 91, 92
- anionic surfactants, determination of 22, 386–388
- anodic stripping voltammetry, determination of
 - cations 114, 123, 134, 166, 172, 210, 217, 248, 316, 322
 - organometallic compounds 6, 44
- antimonate, determination of 91
- antimony
 - determination of 119, 229, 233, 235, 244, 247, 253, 262, 323
 - sampling of 2, 3
- aromatic hydrocarbons, determination of 368, 369
- arsenate, determination of 41, 88, 89, 91
- arsenic
 - determination of 120–124, 219, 232, 238, 241–247, 262, 313, 314, 323
 - preservation 24
 - sampling 2
- arsenite, determination of 41–88, 89, 91
- atomic absorption spectrometry
 - of anions 48, 49, 56, 65, 101
 - of cations 101, 114, 119, 121, 124, 125, 126, 128, 129, 135, 138, 148, 154, 163, 166, 174, 203, 205, 207, 213, 216, 220, 223–239, 314–318, 323
 - of organic compounds 379
 - of organometallic compounds 444, 450, 455
- atomic emission spectrometry, determination of organometallic compounds 459
- atomic fluorescence spectroscopy, determination of cations 150, 168
- azarines, determination of 400
- azine herbicides, determination of 411
- barium, determination of 124, 125, 262, 265, 266, 313, 314
- benzoate, determination of 41
- beryllium, determination of 125, 247
- biochemical oxygen demand
 - determination of 21, 496
- bismuth, determination of 126, 127, 229, 233, 244, 253
- Blumer sampler 5
- Bodeja-Bodman bottle 6

- borate, determination of 42
boron, determination of 127, 128, 467
bromate, determination of 42–45
bromide, determination of 45, 46,
89, 90
bromine, determination of 266
bromo-organic compounds,
0 determination of 49, 50
butyrate, determination of 41
- cadmium
– determination of 14, 128–134, 220,
223–225, 229–232, 241–270, 315,
320–323, 365
– preservation 22, 23
- caesium,
– determination of 136, 270
– preservation of 24, 25
- calcium, determination of 136–139,
219, 262, 316
- carbohydrates, determination of
382, 385
- carbon dioxide, determination of 108,
109
- carbon functions, determination of
472–493
- carboxylic acids, determination of
377–379
- cathodic stripping voltammetry
– determination of anions 63, 69, 72
– determination of cations 151, 191, 192,
202, 211, 214, 259, 322
- cationic surfactants, determination
of 386
- cations, preconcentration 288, 374
- cerium, determination of 136, 194, 196,
266, 267
- chelators, determination of 415
- chemical oxygen demand, determination
of 21, 490–495
- chemiluminescence of
– anions 68
– cations 150, 166, 219
- chloride, determination of 47, 48
- chlorodioxines, determination of 393
- chloro-insecticides, determination of
403–409
- chlorophyll, determination of 20
- chlorothalonil, determination of 412
- chromate, determination of 48, 53, 91
- chromium, determination of 139–145,
224, 232, 241–251, 261, 265, 267, 270,
321, 322
- chronopotentiometry
– determination of anions 48
– determination of cations 260
- coastal water
– determination of anions 99–102
- cobalamin, determination of 423
- cobalt
– determination of 148–151, 220–224,
232, 241–247, 251, 259, 261–267,
320–322
– preservation 24, 25
– sampling 13, 14
- continuous flow analysis
– determination of anions 69, 75
- copper
– determination of 14, 16, 132–157, 220,
225, 229, 232, 241–248, 251–271, 316,
317, 320–323
– sampling 10, 13, 14, 24, 25
– speciation 157
- coulometry, determination of
cations 128
- coprecipitation techniques 353
- cyanide, determination of 20, 21
- cysteine, determination of 403
- dichromate, determination of 48–53
- dimethyl sulfoxide, determination
of 402
- diuron, determination of 412
- dynamic headspace analysis,
determination of organics 366
- dysprosium, determination of
163, 196
- electron spin resonance spectroscopy of
cations 157
- electrostatic ion chromatography of
anions 89, 90
- emission spectroscopy, determination of
anions 109
- erbium, determination of 163, 196
- estuary waters, determination of anions
99–102
- ethylene diamine tetracetic acid,
determination of 401
- europium, determination of 163, 196

- flavins, determination of 426
flow injection analysis of
– anions 68, 72–76, 84
– cations 148, 168, 217
– gases 108
fluoride, determination of 53–56, 91
fluorobenzazole, determination of 402
formate, determination of 57
fractionation techniques 361
free chlorine, determination of
103–108
freeze drying 350, 351
froth flotation 351
- gadolinium, determination of 163, 196
gallium, determination of 163, 262
garvey sampler 4
gas chromatography, determination of
– anions 55, 108
– cations 114, 203, 207
– organic compounds 373, 377, 381,
403, 405, 411
– organometallic compounds 452, 456
gas chromatography-mass spectrometry,
determination of 375, 382, 411, 466
gas stripping 357–361
gel permeation chromatography,
determination of cations 174
germanium, determination of 163
Go-Flow sampler 8–11, 13, 15
gold, determination of 164, 267
- Harvey drum samples 4
headspace sampler, determination of
gases 108–109
high performance liquid
chromatography, determination of
– anions 57, 58
– cations 111, 209, 271, 318
– organic compounds 369, 378, 384,
404, 408, 410, 461
holmium, determination of 164, 196
humic materials, determination of 416
hydrobios sampler 9, 10, 25
hydrocarbons, preservation 29
hydrogen ion concentration,
determination of 21, 89, 90
hydrogen sulphide, determination
of 108
hydrowire sampler 8–12
- hydroxy acids, determination of
377–379
hydroxylamine, determination of 400
hypochlorite, determination of 58
- indium
– determination of 164, 229, 244, 247
– preservation 24, 25
inductively coupled plasma atomic
emission spectrometry,
determination of
– anions 86, 87
– cations 139, 184, 319
inductively coupled plasma mass
spectrometry, determination of
– cations 123, 164, 184, 188, 214, 244,
323
international council for exploration of
sea 7
iodate, determination of 58–61
iodide, determination of 62–65, 89, 90
iodine, determination of 467
ion chromatography of anions 9, 41, 64,
69, 82, 88
ion exclusion chromatography,
determination of anions 455
ion interaction chromatography,
determination of anions 75
ion selective electrodes, determination of
– anions 47, 53–56, 109
– cations 118, 138, 155, 194
irgalol, determination of 412
iridium, determination of 165, 230
iron
– determination of 165–167, 220, 229,
242–247, 260–271, 320–322
– preservation 24, 25
– sampling 13, 14
isotachaelectrophoresis,
determination of
– anions 46, 85, 86
– gases 108
isotope dilution analysis,
determination of
– anions 72
– cations 57
- ketones, determination of 380, 381
lanthanum, determination of 167, 266,
271

- lead
– determination of 15, 16, 168–174, 220–224, 229, 232, 241–258, 261, 268, 269, 320–322
– preservation 75
– sampling 13–15
lipids, determination of 412
lithium, determination of 174, 223, 268
lutecium, determination of 175, 196
- magnesium, determination of 175–180, 229, 232, 241–247, 260–271, 318, 320–323
mass spectrometry, determination of cations 174, 192, 201, 206, 268, 319
mercury
– determination of 180–186, 229–245, 253, 262, 264, 267, 317, 318
– preservation 21, 25, 26
– sampling 1, 14, 15
metals, preservation 21
microcystine, determination of 426
molybdate, determination of 65, 91
molybdenum, determination of 65, 91, 180–189, 229, 232, 243, 260, 262, 265
- neodymium, determination of 189, 195
neutron activation analysis 122, 164, 174, 180, 200, 204, 205, 206, 214, 262
nickel
– determination of 14, 16, 190–192, 220–224, 232, 241–247, 259–271, 320–323
– sampling 9, 13, 14
Niskin bottle sampler 6, 9, 10, 15
nitrate, determination of 21, 65–71, 73–76, 89, 90, 99, 100, 102
nitric oxide, determination of 108
nitrite, determination of 21, 71, 73–5, 99, 100
nitro compounds, determination of 399
nitrogen compounds, determination of 393, 394
nitrogen elemental, determination of 468–470
non-ionic surfactants, determination of 22, 388, 389
nucleic acids, determination of 397
- oil spills, examination of 20, 370–377
- organic compounds, preconcentration 426
organoarsenic compounds, determination of 443–446
organocadmium compounds, determination of 446
organochromium compounds, determination of 49, 50
organocopper compounds, determination of 446
organolead compounds, determination of 447
organomercury compounds, determination of 447–454
organophosphorus compounds, determination of 409–411
organosulfur compounds, determination of 401–403
organothallium compounds, determination of 454
organotin compounds, determination of 455–461
osmium, determination of 192
oxygen isotopes, determination of 192
ozone, determination of 108
- palladium, determination of 192
pecteno toxins, determination of 423
peptides, determination of 397
perrhenate, determination of 76, 91
pesticides, fixing 20
phenols, determination of 22, 381, 382
phosphate
– determination of 22, 76–82, 88, 89, 100, 102
– preservation 29
– phosphorus, determination of 470
photoactivation analysis of anions 56
phthalates
– determination of 382
– preservation 26, 27, 29
plant pigments, determination of 416–423
platinum, determination of 192, 230
plutonium, determination of 192, 336, 339
polarography
– determination of anions 42–45, 87, 88
– determination of cations 151, 180, 193, 212, 318

- polonium, determination of 193
polyaromatic hydrocarbons
– determination of 369
– preservation 29
polychlorobiphenyls, determination of 26, 27, 404
potassium, determination of 193, 223, 262
praseodymium, determination of 194, 195
preconcentration of
– anions 92
– cations 288, 324
– organic compounds 426
preservation of seawater 17
promethium, determination of 194, 195
propionate, determination of 82
protein, determination of 397
pyruvate, determination of 82
- radioactive element, determination of 328–348
radioactinium, determination of 328
radiobarium, determination of 331
radiocobalt, determination of 338
radioiron, determination of 338
radiolead, determination of 328, 331
radiomanganese, determination of 338
radiosmium, determination of 341
radiophosphorus, determination of 335
radiopolonium, determination of 328
radiatorhenium, determination of 341
radiotechnetium, determination of 333
radiouranium, determination of 342
radium, determination of 194, 31
raman spectroscopy of organic compounds 368
rare earths, determination of 194, 197
reverse osmosis 350
rhenium, determination of 199, 200
rubidium
– determination of 200, 201, 208, 223, 247, 262
– preservation 24, 25
ruthenium, determination of 201
- samarium, determination of 195, 201
sample containers 30–31
sample contamination 27–33
sample preparation 349–364
sampling procedure 1–17
sampling devices 5–7
scandium
– determination of 201, 266, 267
– preservation 24, 25
selenate, determination of 87, 100, 101
selenite, determination of 82, 83, 100, 101
selenium, determination of 201–203, 229, 232–244, 260, 262, 318
segmented flow analysis, determination of anions 46
sodium, determination of 204, 205
solvent extraction 351–353
solid state membrane electrodes, determination of anions 46
speciation cations 157, 271
spectrofluorimetry of
– anions 82, 83, 100
– cations 113, 150, 216
– organic compounds 368, 370
spectrophotometry of
– anions 40–45, 53, 58–61, 63, 65, 73, 77–84, 88, 100, 102
– cations 112, 115, 127, 148, 155, 165, 166, 186, 190, 202, 207, 211, 213, 219
– organic compounds 377, 380, 381, 382
– organometallic compounds 445
sterols, determination of 413
strontium
– determination of 205, 219, 262
– preservation 24, 25
sulfate, determination of 56–88, 100, 102
sulfide, determination of 20, 22, 85, 86, 88, 89, 102
sulfur, determination of 471, 472
surface films, analysis of 3–7
suspended solids, determination of 90–92
- technetium, determination of 205–207
tellurium, determination of 205, 229, 233
terbium, determination of 197, 206
thallium, determination of 206, 229, 244, 269
thiols, determination of 402

- thorium, determination of 206, 207,
265, 266, 337
- thullium, determination of 196, 207
- tin, determination of 208–212, 229, 233,
265, 318, 319
- titanium, determination of 211, 262
- tungsten, determination of 211
- ultraviolet spectroscopy, determination
of anions 66, 67, 99
- uranium
- determination of 211, 212, 260,
262–270, 322
 - preservation 24, 25
- urea, determination of 400
- valerate, determination of 88
- vanadium, determination of 213, 214,
229, 243, 247, 260, 267, 268
- vitamins, determination of 423
- voltammetry, determination of organic
compounds 380
- volatile organic compounds,
determination of 392, 393
- World Meteorological Commission 7
- X-ray emission spectrometry,
determination of anions 45
- X-ray fluorescence spectroscopy,
determination of
- anions 45
 - cations 124, 189, 201, 261
 - organic compounds 411
- ytterbium, determination of 196
- yttrium, determination of 215, 233, 262
- zinc
- determination of 215–218, 220, 233,
242–250, 254, 261, 265–269, 320–322
 - preservation 22–25
 - sampling 13, 14
- zirconium, determination of 218–220,
262