

# Introduction to Machine Design

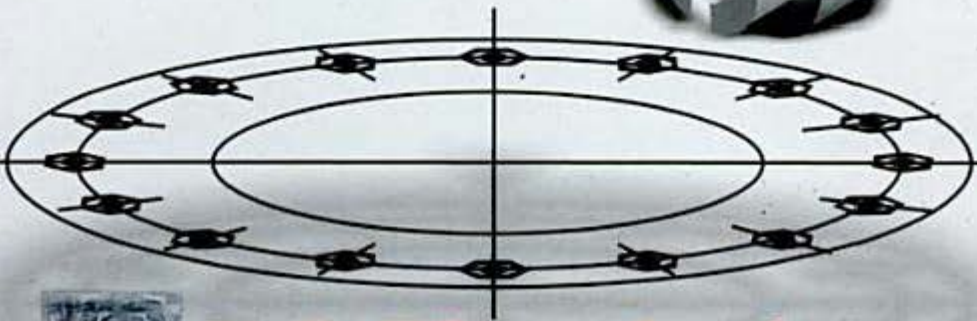

**V B Bhandari**

Information contained in this work has been obtained by Tata McGraw-Hill, from sources believed to be reliable. However, neither Tata McGraw-Hill nor its authors guarantee the accuracy or completeness of any information published herein, and neither Tata McGraw-Hill nor its authors shall be responsible for any errors, omissions, or damages arising out of use of this information. This work is published with the understanding that Tata McGraw-Hill and its authors are supplying information but are not attempting to render engineering or other professional services. If such services are required, the assistance of an appropriate professional should be sought.

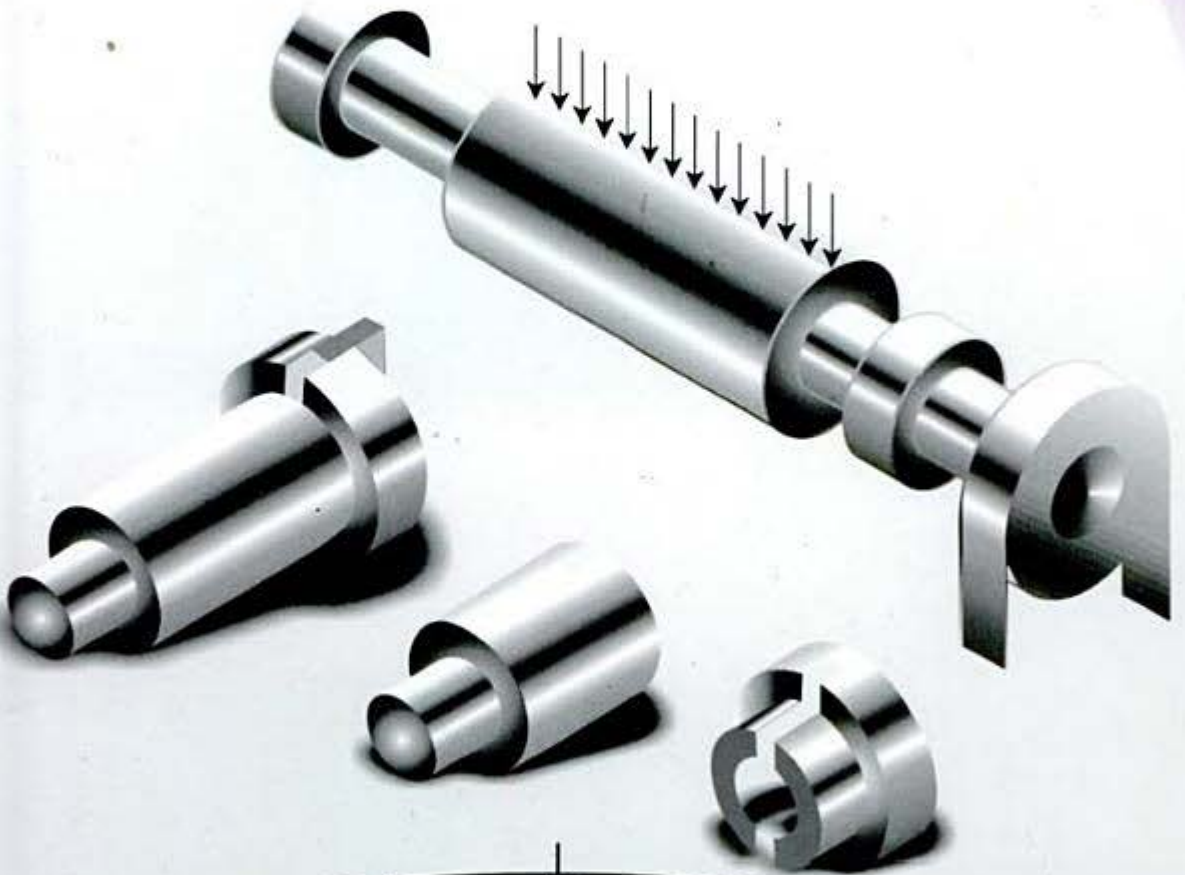

**Tata McGraw-Hill**

© 2001, by Tata McGraw-Hill Publishing Company Limited.

Tenth reprint 2008  
RXDYRYXRAZLQ

No part of this publication may be reproduced or distributed in any form or by any means, electronic, mechanical, photocopying, recording, or otherwise or stored in a database or retrieval system, without the prior written permission of the publishers. The program listings (if any) may be entered, stored and executed in a computer system, but they may not be reproduced for publication.

This edition can be exported from India only by the publishers,  
Tata McGraw-Hill Publishing Company Limited.

ISBN-13: 978-0-07-043449-3  
ISBN-10: 0-07-043449-2

Published by Tata McGraw-Hill Publishing Company Limited,  
7 West Patel Nagar, New Delhi 110 008, typeset at Anvi Composers,  
A1/33 Pashchim Vihar, New Delhi 110 063 and printed at  
Adarsh Printers, Delhi 110 032

*The McGraw-Hill Companies*

Copyrighted material

# Contents

<i>Preface</i>	v
<i>Acknowledgements</i>	vii
<b>1. Introduction</b>	<b>1</b>
1.1 Machine	1
1.2 Machine Design	2
1.3 Basic Procedure of Machine Design	3
1.4 Design Engineer	6
1.5 Basic Requirements of Machine Elements	7
1.6 Design of Machine Elements	9
1.7 Sources of Design Data	13
1.8 Use of Standards in Design	15
1.9 Selection of Preferred Sizes	17
1.10 Economic Considerations in Design	19
1.11 Manufacturing Considerations in Design	21
1.12 Aesthetic Considerations in Design	24
1.13 Ergonomic Considerations in Design	25
Review Questions	27
<b>2. Properties of Engineering Materials</b>	<b>31</b>
2.1 Stress-Strain Diagrams	31
2.2 Mechanical Properties of Engineering Materials	36
2.3 Creep	40
2.4 Stress Concentration	41
2.5 Static and Dynamic Loads	48
2.6 Cyclic Loads and Stresses	51
2.7 Fatigue Failure	51
2.8 Endurance Limit	55
2.9 Selection of Material	58
2.10 Cast Iron	59
2.11 Design Considerations of Castings	61
2.12 B.I.S. System of Designation of Steels	65
2.13 Plain Carbon Steels	68

2.14 Free Cutting Steels 69  
2.15 Alloy Steels 69  
2.16 Overseas Standards 71  
2.17 Heat Treatment of Steels 74  
2.18 Case Hardening of Steels 75  
2.19 Cast Steel 77  
2.20 Aluminium Alloys 78  
2.21 Copper Alloys 81  
2.22 Die Casting Alloys 83  
2.23 Ceramics 83  
2.24 Plastics 85  
2.25 Fibre Reinforced Plastics 90  
2.26 Natural and Synthetic Rubbers 92  
Review Questions 92

**3. Design of Simple Machine Parts 98**

---

3.1 Factor of Safety 98  
3.2 Tensile and Compressive Stresses 101  
3.3 Shear Stress and Shear Strain 103  
3.4 Stresses Due to Bending Moment 104  
3.5 Stresses Due to Torsional Moment 106  
3.6 Design of Simple Machine Parts 107  
3.7 Cotter Joint 117  
3.8 Design Procedure for Cotter Joint 125  
3.9 Cotter Foundation Bolts 132  
3.10 Knuckle Joint 135  
3.11 Design Procedure for Knuckle Joint 144  
3.12 Levers 151  
3.13 Design of Levers 152  
3.14 Arms of Cast Iron Pulley 189  
3.15 Eccentric Axial Loading 195  
3.16 Principal Stresses 204  
3.17 Theories of Elastic Failure 207  
3.18 Maximum Principal Stress Theory 208  
3.19 Maximum Shear Stress Theory 209  
Review Questions 211  
Problems 212

**4. Shafts, Keys and Couplings 216**

---

4.1 Transmission Shafts 216  
4.2 Shaft Design on Strength Basis 218  
4.3 Shaft Design on Torsional Rigidity Basis 222  
4.4 Design of Hollow Shaft on Strength Basis 223  
4.5 Design of Hollow Shaft on Torsional Rigidity Basis 226

4.6	<u>A.S.M.E. Code for Shaft Design</u>	226
4.7	<u>Keys</u>	251
4.8	<u>Saddle Keys</u>	253
4.9	<u>Sunk Keys</u>	254
4.10	<u>Feather Key</u>	256
4.11	<u>Woodruff Key</u>	256
4.12	<u>Stress Equations of Key</u>	258
4.13	<u>Strength Equations of Key</u>	260
4.14	<u>Length of Square Key</u>	261
4.15	<u>Couplings</u>	275
4.16	<u>Muff Coupling</u>	277
4.17	<u>Design Procedure for Muff Coupling</u>	278
4.18	<u>Clamp Coupling</u>	281
4.19	<u>Design Procedure for Clamp Coupling</u>	284
4.20	<u>Flange Coupling</u>	287
4.21	<u>Design Procedure for Rigid Flange Coupling</u>	291
4.22	<u>Bushed-Pin Flexible Coupling</u>	301
4.23	<u>Design Procedure for Bushed-Pin Type Flexible Coupling</u>	305
	<i>Review Questions</i>	317
	<i>Problems</i>	320
<b>5.</b>	<b><u>Power Screws</u></b>	<b>325</b>
5.1	<u>Power Screws</u>	325
5.2	<u>Forms of Threads</u>	326
5.3	<u>Multiple Threaded Screws</u>	329
5.4	<u>Terminology of Power Screw</u>	330
5.5	<u>Torque Requirement—Lifting Load</u>	332
5.6	<u>Torque Requirement—Lowering Load</u>	333
5.7	<u>Self-Locking Screw</u>	334
5.8	<u>Efficiency of Square Threaded Screw</u>	335
5.9	<u>Efficiency of Self-Locking Screw</u>	337
5.10	<u>Trapezoidal and Acme Threads</u>	337
5.11	<u>Collar Friction Torque</u>	339
5.12	<u>Overall Efficiency</u>	340
5.13	<u>Coefficient of Friction</u>	341
5.14	<u>Stresses in Screw and Nut</u>	341
5.15	<u>Buckling of Columns</u>	342
	<i>Review Questions</i>	398
	<i>Problems</i>	400
<b>6.</b>	<b><u>Threaded Joints</u></b>	<b>402</b>
6.1	<u>Threaded Joints</u>	402
6.2	<u>Basic Types of Screw Fastening</u>	403
6.3	<u>CAP Screws</u>	405

6.4 Setscrews 407  
6.5 Bolt of Uniform Strength 408  
6.6 Locking Devices 410  
6.7 Terminology of Screw Threads 412  
6.8 I.S.O. Metric Screw Threads 413  
6.9 Bolt Under Tension 416  
6.10 Bolts for Cylinder Cover 420  
6.11 Eccentrically Loaded Bolted Joints in Shear 423  
6.12 Eccentric Load Perpendicular to Axis of Bolt 428  
6.13 Eccentric Load on Circular Base 442  
6.14 Torque Requirement for Bolt Tightening 454  
6.15 Dimensions of Fasteners 456  
*Review Questions 465*  
*Problems 467*

**7. Welded Joints**

**471**

7.1 Welded Joints 471  
7.2 Butt Joints 473  
7.3 Fillet Joints 474  
7.4 Strength of Butt Welds 475  
7.5 Strength of Parallel Fillet Welds 477  
7.6 Strength of Transverse Fillet Welds 479  
7.7 Maximum Shear Stress in Parallel Fillet Weld 484  
7.8 Maximum Shear Stress in Transverse Fillet Weld 487  
7.9 Axially Loaded Unsymmetrical Welded Joints 490  
7.10 Eccentric Load in Plane of Welds 492  
7.11 Welded Joint Subjected to Bending Moment 502  
7.12 Welded Joint Subjected to Torsional Moment 510  
7.13 Strength of Welded Joints 512  
7.14 Welding Symbols 513  
7.15 Weld Inspection 515  
*Review Questions 516*  
*Problems 517*

**8. Riveted Joints**

**520**

8.1 Riveted Joints 520  
8.2 Types of Rivet Head 523  
8.3 Types of Riveted Joints 526  
8.4 Rivet Materials 528  
8.5 Types of Failure 529  
8.6 Strength Equations 530  
8.7 Efficiency of Joint 533  
8.8 Caulking and Fullering 533  
8.9 Longitudinal Butt Joint for Boiler Shell 542

- 8.10 Circumferential Lap Joint for Boiler Shell 556  
 8.11 Eccentrically Loaded Riveted Joint 564  
     *Review Questions* 576  
     *Problems* 577

**9. Bearings and Seals** **581**

---

- 9.1 Bearings 581  
 9.2 Comparison of Sliding and Rolling Contact Bearings 582  
 9.3 Types of Sliding Contact Bearing 585  
 9.4 Construction of Sliding Contact Bearings 588  
 9.5 Bearing Materials 589  
 9.6 Lubricating Oils 592  
 9.7 Self-Aligning Bearing 593  
 9.8 Types of Rolling Contact Bearing 594  
 9.9 Static Load Carrying Capacity 598  
 9.10 Dynamic Load Carrying Capacity 598  
 9.11 Equivalent Bearing Load 598  
 9.12 Load-Life Relationship 599  
 9.13 Selection of Bearing Life 600  
 9.14 Selection of Bearing From Manufacturer's Catalogue 601  
 9.15 Bearing Failure—Causes and Remedies 607  
 9.16 Lubrication of Rolling Contact Bearings 608  
 9.17 Mounting of Bearings 609  
 9.18 Gasket, Seal and Packing 611  
     *Review Questions* 613

*Index* **617**

---

# Introduction

*'Successful designers are those who can work as a part of a team to formulate a strategy and together design an effective product.'*

—John G Falcioni<sup>1</sup>

## 1.1 MACHINE

A machine is defined as a combination of rigid and resistant bodies having definite motion and capable of performing some useful work. The definition of machine contains following important features:

1. A machine must be capable of doing some useful work, otherwise it cannot be called machine. For example, a car transports passengers, a pump raises water from well, a washing machine cleans clothes while a drilling machine makes holes.
2. A machine consists of a number of fixed and moving parts called 'links'. The moving parts of the machine must have controlled and constrained motion. For example, when the handle of the screw jack is rotated through one revolution, the load is raised along the axis of the screw, through a distance equal to the pitch of the screw with single start threads.
3. The various parts of the machine are interposed between the source of power and the work to be done for the purpose of adapting one to another. This concept of machine is illustrated in Fig. 1.1. The source of power can be electric motor, engine or even manual power as in case of hand operated machines. The output work can be turning in case of lathe or blanking in case of press.
4. A machine transforms and transfers energy. A car converts chemical energy of fuel into heat energy and finally into mechanical energy. An electric motor transforms electrical energy into mechanical energy. A

1. John G. Falcioni, 'Designs that work', *Mechanical Engineering*, Vol. 117, No. 3, March, 1995.



transfer, vibrations and fluid mechanics. Some of the examples of these principles are,

- (i) Newton's laws of motion,
  - (ii) D' Alembert's principle,
  - (iii) Boyle's and Charles' laws of gases,
  - (iv) Carnot cycle, and
  - (v) Bernoulli's principle.
2. The designer has technical information of the basic elements of a machine. These elements include fastening devices, chain, belt and gear drives, bearings, oil seals and gaskets, springs, shafts, keys, couplings and so on. A machine is a combination of these basic elements. The designer knows the relative advantages and disadvantages of these basic elements and their suitability in a particular application.
  3. The designer uses his skill and imagination to produce a configuration, which is a combination of these basic elements. However, this combination is unique and different in different situations. This intellectual part of selection of proper configuration is creative in nature.
  4. The final outcome of design process consists of description of the machine. The description is in the form of drawings of assembly and individual components.
  5. A design is created to satisfy a recognised need of the customer. The need may be to perform a specific function with maximum economy and efficiency.

Machine design establishes and defines solutions and pertinent structures for problems not solved before and provides new solutions to problems that have previously been solved in a different way. Design should not be confused with the word 'discovery'. Discovery means getting the first sight of, or the first knowledge of something. For example, Columbus discovered America. We can discover what has already existed but has not been known before. On the other hand, machine design creates a machine that has not existed, instead, it is created expressly to satisfy the need of the customer.

### 1.3 BASIC PROCEDURE OF MACHINE DESIGN

The basic procedure of machine design consists of a step-by-step approach, from given specifications about the functional requirements of a product to the complete description, in the form of drawings, of the final product. A logical sequence of steps, usually common to all design projects, is illustrated in Fig. 1.2. These steps are interrelated and interdependent, each reflecting and affecting all other steps. Following steps are involved in the process of machine design,

#### 1. Product Specifications

The first step consists of preparing a complete list of specifications giving the requirements of the product. The requirements include the output capacity of the

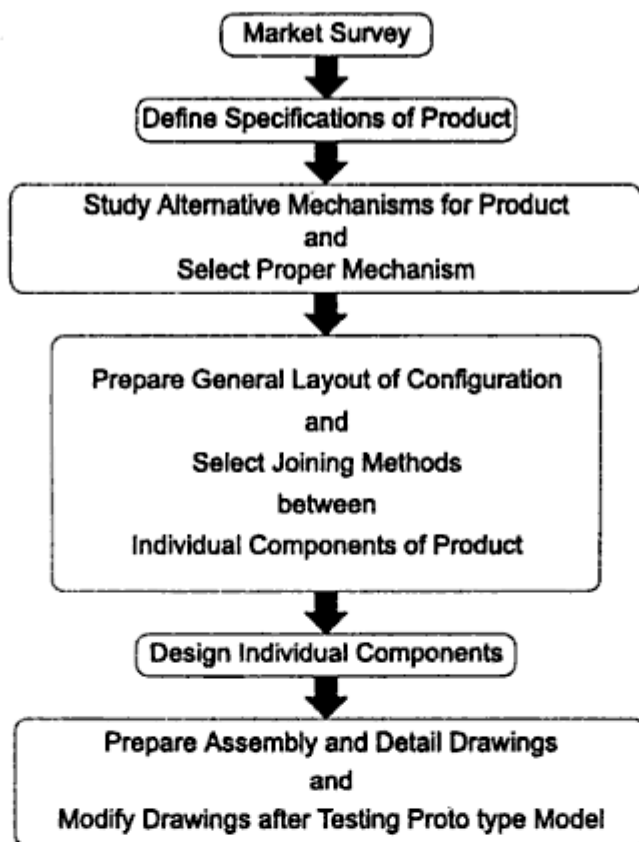

Fig. 1.2 Design Process

machine, service life, cost and reliability. In some cases, the overall dimensions and weight of the product are specified. For example, while designing a scooter, the list of specifications will be as follows:

- (i) fuel consumption = 40 km/l.
- (ii) maximum speed = 85 km/ hr.
- (iii) carrying capacity = two persons with 10 kg luggage.
- (iv) overall dimensions:
  - width = 700 mm.
  - length = 1750 mm.
  - height = 1000 mm.
- (v) weight = 95 kg.
- (vi) cost = Rs 12000 to 15000.

In consumer products, appearance, noiseless operation and simplicity in controls are important requirements. Depending upon the type of product, various requirements are given weightages and a priority list of specifications is prepared.

## 2. Selection of Mechanism

After careful study of the requirements, the designer prepares rough sketches of different possible mechanisms for the product. For example, while designing a blanking or piercing press, the following mechanisms are possible:

- (i) mechanism involving crank and connecting rod, converting the rotary motion of the electric motor into the reciprocating motion of the punch,
- (ii) mechanism involving nut and screw, which is simple and cheap configuration but having poor efficiency, and
- (iii) mechanism consisting of hydraulic cylinder, piston and valves which is costly configuration but highly efficient.

The alternative mechanisms are compared with each other and also with the mechanisms of products available in the market. An approximate estimation of the cost of each alternative configuration is made and compared with the cost of existing products. This will reveal the competitiveness of the product. While selecting the final configuration, the designer should consider whether the raw materials and standard parts required for making the product are available in the market. He should also consider whether the manufacturing processes required to fabricate the components are available in the factory. Depending upon the cost-competitiveness, availability of raw materials and manufacturing facility, the best possible mechanism is selected for the product.

### 3. Layout of Configuration

The next step in design procedure is to prepare a block diagram showing the general layout of the selected configuration. For example, the layout of an E.O.T. (Electrically-operated Overhead Travelling) crane will consist of following components:

- (i) Electric motor for supply of power,
- (ii) Flexible coupling to connect the motor shaft to the clutch shaft;
- (iii) Clutch to connect or disconnect the electric motor at the will of the operator,
- (iv) Gear box to reduce the speed from 1440 rpm to about 15 rpm,
- (v) Rope drum to convert the rotary motion of the shaft to the translational motion of the wire rope,
- (vi) Wire rope and pulley with the crane hook to attach the load, and
- (vii) Brake to stop the motion.

In this step, the designer specifies joining methods, such as riveting, bolting or welding to connect individual components. Rough sketches of shapes of the individual parts are prepared.

### 4. Design of Individual Components

The design of individual components or machine elements is an important step in design procedure. It consists of following stages:

- (i) Determine the forces acting on each component,
- (ii) Select proper material for the component depending upon the functional requirements such as strength, rigidity, hardness, wear resistance and bearing properties,

- (iii) Determine the likely mode of failure for the component and depending upon it, select the criterion of failure, such as yield strength, ultimate tensile strength, endurance limit or permissible deflection, and
- (iv) Determine the geometric dimensions of the component using suitable factor of safety and modify the dimensions from assembly and manufacturing considerations.

This stage involves detailed stress and deflection analysis. The subjects 'Machine Design' or 'Elements of Machine Design' cover mainly design of machine elements or individual components of the machine. Article No. 1.6 on design of machine elements gives details of this important step in design procedure.

## **5. Preparation of Drawings**

The last stage in design process is to prepare drawings of the assembly and the individual components. On these drawings, the material of the component, its dimensions, tolerances, surface finish grades and machining symbols are specified. The designer prepares two separate lists of components—standard components to be purchased directly from the market and special components to be machined in the factory. In many cases, a prototype model is prepared for the product and thoroughly tested before finalising the assembly drawings.

It is seen that process of machine design involves systematic approach from known specifications to unknown solutions. Quite often, problems arise on the shop floor during the production stage and design may require modification. In such circumstances, the designer has to consult the manufacturing engineer and find out the optimum solution.

### **1.4 DESIGN ENGINEER**

A design engineer is expected to exhibit a variety of different talents and backgrounds. They include<sup>2</sup>:

- (i) Ability to work well in a team,
- (ii) Greater ability to communicate and 'sell' one's ideas-orally, electronically and on paper-not only among fellow employees, but to the suppliers and the customers,
- (iii) More manufacturing experience or at least ability to work with and communicate with manufacturing persons,
- (iv) Greater flexibility, performing more and different tasks,
- (v) Greater computer-aided design and manufacturing (CAD/CAM) background and some experience in solid modelling,
- (vi) Greater creativity,
- (vii) Increased problem-solving or project experience,

---

2. James Braham, 'Employees demand new skills—Design engineer', *Machine Design*, Vol. 64, No. 19, September, 1992.

**(i) Strength** A machine part should not fail under the effect of the forces that act on it. It should have sufficient strength to avoid failure either due to fracture or due to general yielding.

**(ii) Rigidity** A machine component should be rigid, i.e. it should not deflect or bend too much due to forces or moments that act on it. A transmission shaft is many times, designed on the basis of lateral and torsional rigidities. In these cases, maximum permissible deflection and permissible angle of twist are criteria for design.

**(iii) Wear resistance** Wear is the main reason for putting the machine part out of order. It reduces useful life of the component. Wear also leads to the loss of accuracy of machine tools. There are different types of wear such as abrasive wear, corrosive wear and pitting. The wear resistance of the machine part can be increased by increasing the surface hardness, e.g. case hardening of gears and cams.

**(iv) Minimum dimensions and weight** A machine part should be sufficiently strong, rigid and wear resistant and at the same time, with minimum possible dimensions and weight. This will result in minimum material and labour costs.

**(v) Manufacturability** Manufacturability is the ease of production, fabrication and assembly. The shape and material of the machine part should be selected in such a way that it can be produced with minimum labour and material costs.

**(vi) Safety** The shape and dimensions of the machine parts should ensure safety to the operators of the machine. The designer should assume the worst possible conditions for design and apply 'fail-safe' principle or 'redundancy principle' in such cases.

**(vii) Conformance to standards** A machine part should conform to the national or international standard covering its profile, dimensions, grade and material used.

**(viii) Reliability** Reliability is probability that a machine part will perform its intended functions under desired operating conditions over a specified period of time. Reliability is sometimes described as 'long term quality'. A machine part should be reliable i.e. it should perform its function satisfactorily over its life time.

**(ix) Maintainability** A machine part should be maintainable. Maintainability is the ease with which a machine part can be serviced or repaired.

**(x) Minimum life cycle cost** Life cycle cost of the machine part is the total cost to be paid by the purchaser for purchasing the part and operating and maintaining it over its life span.

It is observed that the above ten basic requirements of machine parts serve two important objectives—reliability and economy. All machine parts must have the capacity to do their specified jobs over the predetermined life span, at least possible manufacturing and operating costs.

## 2. Determination of Forces

In many cases, a free body diagram of forces is constructed to determine the forces acting on different parts of the machine. The external and internal forces that act on machine element are as follows :

- (i) The external force due to energy, power or torque transmitted by the machine part. It is often called 'useful' load.
- (ii) Static force due to deadweight of the machine part.
- (iii) Force due to frictional resistance.
- (iv) Inertia force due to change in linear or angular velocity.
- (v) Centrifugal force due to change in direction of velocity.
- (vi) Force due to thermal gradient or variation in temperature.
- (vii) Force set up during manufacture of the part resulting in residual stresses.
- (viii) Force due to particular shape of the part such as abrupt change in cross-section resulting in stress concentration.

For every machine element, all forces in the above mentioned list may not be applicable. They vary from application to application. There is one more important consideration. The force acting on the machine part is either assumed to be concentrated at some point in the machine part or distributed over a particular area. Experience is essential to make such assumptions in the analysis of forces.

## 3. Selection of Material

The selection of suitable material for the machine element depends upon following two factors:

- (i) shape of the part; and
- (ii) type of load.

For example, flywheel, housing of gear box or bracket have complex shapes. These components are made of cast iron because casting process produces complicated shapes without involving machining operations. Transmission shafts are made of plain carbon steels, because they are available in the form of rods, besides their higher strength. The automobile body and hood are made of low carbon steels because their cold formability is essential to press the parts. Free cutting steels have excellent machinability due to addition of sulphur. They are ideally suitable for bolts and studs because of the ease with which the thread profiles can be machined. Crankshaft and connecting rod are subjected to fluctuating forces and nickel-chromium steel is used to make these components due to higher fatigue strength. Four basic factors which should be considered while selection of material are availability, cost, mechanical properties and manufacturing considerations. These factors are discussed in detail in Article 2.9.

## 4. Failure Criterion

Before finding out the dimensions of the component, it is necessary to know the type of failure by which the component will fail when put into the service. The

machine component is said to have 'failed' when it is unable to perform its functions satisfactorily. The three basic types of failure are as follows;

- (i) failure by elastic deflection,
- (ii) failure by general yielding, and
- (iii) failure by fracture.

In applications like transmission shaft supporting gears, the maximum force acting on the shaft is limited by the permissible elastic deflection. When this deflection exceeds a particular value (0.001 to 0.003 times of span length between two bearings), the meshing between teeth of gears is affected and the shaft cannot perform its function properly. In this case, the shaft is said to have 'failed' due to elastic deflection. Components made of ductile materials like steel lose their engineering usefulness due to large amount of plastic deformation. This type of failure is called failure by yielding. Components made of brittle materials like cast iron cease to function because of sudden fracture without any plastic deformation. There are two basic modes of gear tooth, failure—breakage of tooth due to static and dynamic load and surface pitting. The surface of gear tooth is covered with small 'pits' resulting in rapid wear. Pitting is a surface fatigue failure. The components of ball bearing such as rolling elements, inner and outer races fail due to fatigue cracks after certain number of revolutions. Fatigue is also the cause of failure for valve springs. Sliding contact bearings fail due to corrosion and abrasive wear by foreign particles. Clutches, bearings and splines fail due to seizure.

## **5. Determination of Dimensions**

The shape of the machine element depends upon two factors viz. the operating conditions and the shape of adjoining machine element. For example, involute profile is used for gear teeth because it satisfies the fundamental law of gearing. V-belt has trapezoidal cross-section because it results in wedge action and increases the force of friction between the surfaces of the belt and the pulley. On the other hand, the pulley of V-belt should have a shape which will match with the adjoining belt. The profile of the teeth of sprocket wheel should match the roller, bushing, inner and outer link plates of the roller chain. Depending upon the operating conditions and shape of adjoining element, the shape of the machine element is decided and a rough sketch is prepared.

The geometric dimensions of the component are determined on the basis of failure criterion. In simple cases, the dimensions are determined on the basis of allowable stress or deflection. For example, a tension rod, illustrated in Fig. 1.4, is subjected to a force of 5 kN. The rod is made of plain carbon steel and permissible tensile stress is  $80 \text{ N/mm}^2$ . The diameter of the rod is determined on the basis of allowable stress using the following expression,

$$\text{Stress} = \frac{\text{force}}{\text{area}}$$

$$80 = \frac{(5 \times 10^3)}{\left(\frac{\pi d^2}{4}\right)}$$

Therefore,  $d = 8.92$  or  $10$  mm

As a second example, consider a transmission shaft, shown in Fig. 1.5, which is used to support a gear. The shaft is made of steel and modulus of elasticity is  $207\,000$  N/mm<sup>2</sup>. For proper meshing between gear teeth, the permissible deflection at the gear is limited to  $0.05$  mm. The deflection of the shaft at the centre is given by,

$$\delta = \frac{Pl^3}{48EI}$$

$$0.05 = \frac{(5 \times 10^3)(200)^3}{48(207\,000)\left(\frac{\pi d^4}{64}\right)}$$

Therefore,  $d = 35.79$  or  $40$  mm

Following observations are made from the above two examples,

- (i) Failure mode for the tension rod is general yielding while elastic deflection is the failure criterion for the transmission shaft.
- (ii) The permissible tensile stress for tension rod is obtained by dividing yield strength by factor of safety. Therefore, yield strength is the criterion of design. In case of transmission shaft, lateral deflection or rigidity is the criterion of design. Therefore, modulus of elasticity is important property for finding out the dimensions of the shaft.

Determination of geometric dimensions is an important step in design of machine elements. Various criteria such as yield strength, ultimate tensile strength, torsional or lateral deflection, permissible bearing pressure or coefficient of friction are used to find out these dimensions.

## 6. Design Modifications

The geometric dimensions of the machine element are modified from assembly and manufacturing considerations. For example, steps and shoulders should be provided on transmission shaft, illustrated in Fig. 1.5, in order to mount the gear and the ball bearings. Revised calculations are carried out for operating capacity, margin of safety at critical cross-sections and resultant stresses taking into consideration the effect of stress concentration. When these values differ from desired values, the dimensions of the component are modified. The process is continued till the desired values of operating capacity, factor of safety and stresses at critical cross-sections are obtained.

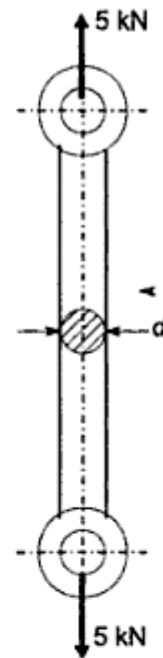
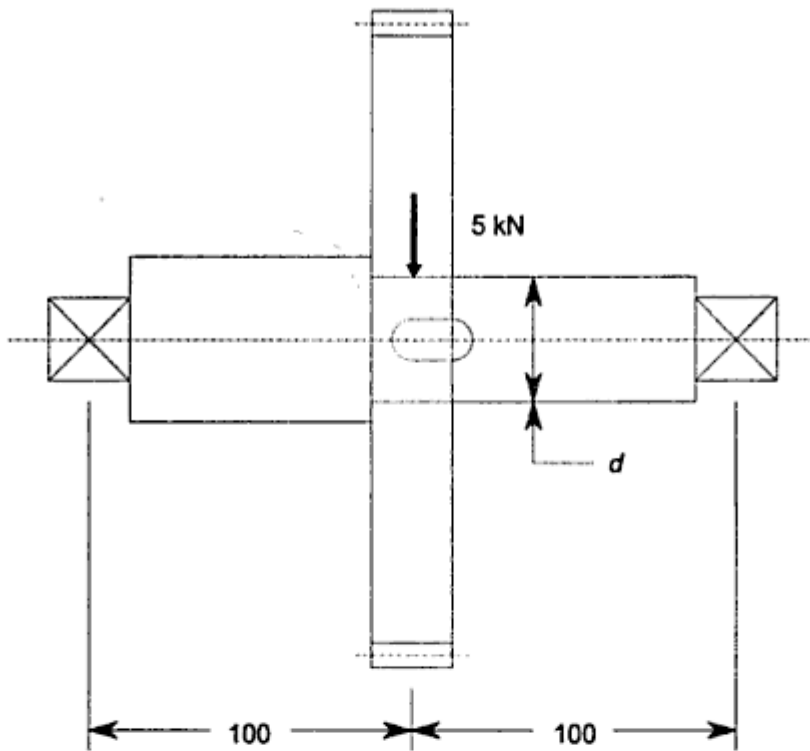

Fig. 1.4 Tension Rod





**Fig. 1.5** Transmission Shaft

## 7. Working Drawing

The last step in the design of machine element is to prepare a working drawing of the machine element showing dimensions, tolerances, surface finish grades, geometric tolerances and special production requirements like heat treatment. The working drawing must be clear, concise and complete. It must have enough views and cross-sections to show all details. The main view of the machine element should show it in a position, it is required to occupy in service. Every dimension must be given. There should not be a place of guesswork and no necessity for scaling the drawing. All dimensions that are important for proper assembly and interchangeability must be given tolerances.

### 1.7 SOURCES OF DESIGN DATA

Designer needs variety of information such as competitive products in the market, available materials and their properties, the sizes and the load capacities of standard components like ball bearings, chains and belts, types of fits and tolerances and so on. It is not possible to design any product without such design data. The information needed in design office is different from that which is required in the research institute. Textbooks and technical papers published in reputed journals are usually required for research projects. On the other hand, the information required in design office is more diverse and less readily available. It has been experienced that design information at the start of any design project is generally insufficient. Very often, it is not clear from where to get the required

- (ii) *Dunlop Transmission Belting, Technical Data*, (Dunlop Industrial Products Service, Calcutta).
- (iii) *Diamond Chain catalogue*, (Diamond Chain Company, Indianapolis, U.S.A.).
- (iv) *Servo Products (Lubricants)*, (Indian Oil Corporation Ltd, Mumbai).
- (v) *Oil Seals, O-Rings and Hydraulic Seals*, (Spare Age Auto Industries, Thane).

#### 5. Data Sheets:

- (i) *Charts of Stress Concentration Factors*, (RE Peterson, John Wiley & Sons, U.S.A.).
- (ii) *Dimensionless Performance Parameters for Journal Bearings*, (Raimondi AA and Boyd John, American Society of Lubricating Engineers).
- (iii) *Notch Sensitivity Charts*, (Sines G and JL Waisman, University of California, U.S.A.).

#### 6. Technical Journals:

- (i) *Machine Design*, Penton Publication, Cleveland, U.S.A.
- 

## 1.8 USE OF STANDARDS IN DESIGN

Standardisation is defined as obligatory norms, to which various characteristics of a product should conform. The characteristics include materials, dimensions and shape of the components, method of testing and method of marking, packing and storing of the product. Following standards are used in mechanical engineering design:

1. *Standards for materials, their chemical compositions, mechanical properties and heat treatment*: For example, Indian standard I.S. 210 specifies seven grades of grey cast iron designated as FG 150, FG 200, FG 220, FG 260, FG 300, FG 350 and FG 400. The number indicates ultimate tensile strength in  $N/mm^2$ . I.S. 1570 (Part 4) specifies chemical composition of various grades of alloy steel. For example, alloy steel designated by 55Cr3 has 0.5 to 0.6% carbon, 0.10 to 0.35% silicon, 0.6 to 0.8% manganese and 0.6 to 0.8% chromium.
2. *Standards for shapes and dimensions of commonly used machine elements*: The machine elements include bolts, screws and nuts, rivets, belts and chains, ball and roller bearings, wire ropes, keys and splines etc. For example, I.S. 2494 (Part 1) specifies dimensions and shape of the cross-section of endless V-belts for power transmission. The dimensions of the trapezoidal cross-section of the belt viz. width, height and included angle are specified in this standard. The dimensions of rotary shaft oilseal units are given in I.S. 5129 (Part 1). These dimensions include inner and outer diameters and width of oilseal units. The dimensions of worm gears are specified in I. S. 3734.
3. *Standards for fits, tolerances and surface finish of component*: For example, selection of the type of fit for a particular application is illustrated in I.S. 2709 on 'Guide for selection of fits'. The tolerances or upper and lower limits for various sizes of holes and shafts are specified in I.S. 919 on 'Recommendations for limits and fits for engineering'. I.S.

3. Standardised parts are easy to replace when worn out due to interchangeability. This facilitates servicing and maintenance of machines. Availability of standardised spare parts is always assured. The work of servicing and maintenance can be carried out even at ordinary service station. These factors reduce the maintenance cost of machines.
4. The application of standardised machine elements and especially standardised units (couplings, cocks, pumps, pressure reducing valves, electric motors) reduce the time and effort needed to design a new machine. It is no longer necessary to design, manufacture and test these elements and units and all that the designer has to do is to select them from the manufacturer's catalogues. On the other hand, enormous amount of work would be required to design a machine if all the screws, bolts, nuts, bearings, etc. had to be designed anew each time. Standardisation results in substantial saving in designer's effort.
5. The standards of specifications and testing procedures of machine elements improve their quality and reliability. Standardised components like SKF bearings, Dunlop belts or Diamond chains have long reputation for their reliability in engineering industries. Use of standardised components improve quality and reliability of the machine to be designed.

In design, the aim is to use as many standardised components as possible for a given machine. The selection of standardised parts in no way restricts the creative initiative of the designer and prevents him from finding better and more rational solutions.

## **1.9 SELECTION OF PREFERRED SIZES**

In engineering design, many times the designer has to specify the size of the product. The 'size' of the product is a general term, which includes different parameters like power transmitting capacity, load carrying capacity, speed, dimensions of the component such as height, length and width, and volume or weight of the product. These parameters are expressed numerically, e.g. 5 kW, 10 kN or 1000 rpm. Often, the product is manufactured in different sizes or models, for instance, a company may be manufacturing seven different models of electric motors ranging from 0.5 kW to 50 kW to cater to the need of different customers. Preferred numbers are used to specify the 'sizes' of the products in these cases.

Preferred numbers were first introduced by the French balloonist and engineer Charles Renard in the 19th century. The system is based on the use of geometric progression to develop a set of numbers. There are five basic series<sup>3</sup>, denoted as R5, R10, R20, R40 and R80 series, which increase in steps of 58%, 26%, 12%, 6%, and 3% respectively. Each series has its own series factor. The series factors are shown in Table 1.2.

---

3. I.S. 1076, 1985: *Preferred numbers*, (in three parts).

Table 1.2

R5 Series	$\sqrt[5]{10} = 1.58$
R10 Series	$\sqrt[10]{10} = 1.26$
R20 Series	$\sqrt[20]{10} = 1.12$
R40 Series	$\sqrt[40]{10} = 1.06$
R80 Series	$\sqrt[80]{10} = 1.03$

The series is established by taking the first number and multiplying it by a series factor to get the second number. The second number is again multiplied by a series factor to get the third number. The procedure is continued until the complete series is built up. The resultant numbers are rounded as per international standards and shown in Table 1.3. As an example, consider a manufacturer of lifting tackles who wants to introduce nine different models of capacities ranging from about 15 to 100 kN. Referring to R10 series, the capacities of different models of lifting tackle will be 16, 20, 25, 31.5, 40, 50, 63, 80 and 100 kN.

Table 1.3 Preferred numbers

R5	R10	R20	R40
1.00	1.00	1.00	1.00
			1.06
		1.12	1.12
			1.18
		1.25	1.25
			1.32
		1.40	1.40
			1.50
		1.60	1.60
			1.70
1.60	1.60	1.80	1.80
			1.90
		2.00	2.00
			2.12
		2.24	2.24
			2.36
		2.50	2.50
			2.65
		2.80	2.80
			3.00
2.50	2.50	3.15	3.15
			3.35
		3.55	3.55
			3.75
		4.00	4.00

(Contd)

<i>R5</i>	<i>R10</i>	<i>R20</i>	<i>R40</i>
			4.25
		4.50	4.50
			4.75
	5.00	5.00	5.00
			5.30
		5.60	5.60
			6.00
6.30	6.30	6.30	6.30
			6.70
		7.10	7.10
			7.50
	8.00	8.00	8.00
			8.50
		9.00	9.00
			9.50
10.00	10.00	10.00	10.00

It is observed from Table 1.2 that small sizes differ from each other by small amounts, while large sizes by large amounts. When the product is manufactured in limited quantity in the initial stages, use is made of the R5 series. As the scale of production is increased change over is made from R5 to R10 series, introducing new sizes of intermediate values of R10 series. Preferred numbers are an important tool, which minimise unnecessary variation in sizes. They assist the designer in avoiding selection of sizes in an arbitrary manner. The complete range is covered by minimum number of sizes which is advantageous to producer and consumer.

### 1.10 ECONOMIC CONSIDERATIONS IN DESIGN

The process of machine design is not complete until the designer has a realistic estimate of the cost required to manufacture the product. In general, it is considered that a design with minimum cost will be successful in free market place. There are three basic parts which together make the total cost of the product. They are called material, labour and overhead costs. Costs are classified in different ways. The popular ways to classify the costs are as follows:

- (i) fixed and variable costs,
- (ii) direct and indirect costs, and
- (iii) recurring and non-recurring costs.

Fixed costs are the costs which are independent of the rate of production of the products. They include salaries of management staff or interest and depreciation on capital investment. Variable costs are the costs which vary with the rate of production. They include material and direct labour costs. A direct cost is a cost which can be directly assigned to a particular product such as material or direct labour costs. Indirect costs are the costs which cannot be directly assigned to a

particular product. Such costs are spread over the entire factory such as overhead costs. Recurring costs are directly related to the manufacture of the product and occur over and over again. On the other hand, non-recurring costs are one-time costs such as capital investment costs.

Sometimes, it is required to find out economic lot size of production for a given product. It is obtained by break-even analysis as shown in Fig. 1.6. The break-even point is obtained by following construction:

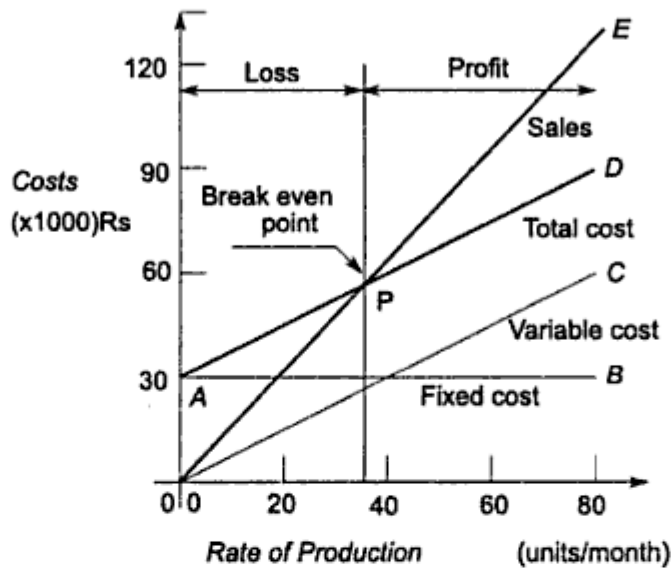

Fig. 1.6 Break Even Analysis

- (i) Since fixed costs such as overhead costs, are independent of the rate of production, it is shown by a straight line  $AB$  parallel to X-axis.
- (ii) Variable costs such as direct labour or material costs, are directly proportional to the rate of production. It is shown by line  $OC$ .
- (iii) Super-imposing the two costs, the total cost of the products is shown by a straight line  $AD$ .
- (iv) Sales amount, i.e. the amount received by selling the products, is directly proportional to the rate of production. It is shown by a line  $OE$ . It is assumed that whatever is produced is sold in the market.
- (v)  $P$  is the point of intersection between lines  $AD$  and  $OE$ . It is observed that upto point  $P$ , the total cost is more than the sales amount indicating loss. After point  $P$ , the total cost is less than the sales amount indicating profit. Point  $P$  is called break-even point, i.e. no-loss, no-profit point.
- (vi) The rate of production should be always more than that of break-even point.

Some of the guidelines for reducing the cost of product are as follows:-

- (i) The number of parts in the product should be as few as possible. The cost of the product decreases as the number of parts is reduced. It also increases reliability of the product. The probability of failure decreases with decreasing number of parts.

solidified into desired shape, e.g. housing of gear box, flywheel with rim and spokes, machine tool beds and guides.

- (ii) *Deformation processes* In these processes, a metal, either hot or cold, is plastically deformed into desired shape. Forging, rolling, extrusion, press working are the examples of deformation processes. The products include connecting rod, crankshaft, I-section beams, car body and springs.
- (iii) *Material removal or cutting processes* In these processes, the material is removed by means of sharp cutting tools. Turning, milling, drilling, shaping, planing, grinding, shaving and lapping are the examples of material removal processes. The products include transmission shafts, keys, bolts and nuts.

In addition, there are joining processes like bolting, welding and riveting. They are essential for the assembly of the product.

Many times, number of manufacturing methods are available to make the component. In such cases, the optimum manufacturing method is selected by considering the following factors:

- (i) Material of the component,
- (ii) Cost of manufacture,
- (iii) Geometric shape of the component,
- (iv) Surface finish and tolerances required, and
- (v) Volume of production.

One of the easiest method to convert the raw material into finished component is casting. There are several casting processes such as sand casting, shell-mould casting, permanent mould casting, die casting, centrifugal casting or investment casting. Sand casting is the most popular casting process. The advantages of sand casting process as a manufacturing method are as follows :-

- (i) The tooling required for casting process is relatively simple and inexpensive. This reduces the cost. Sand casting is one of the cheapest method of manufacturing.
- (ii) Almost any metal such as cast iron, aluminium, brass or bronze can be cast by this method.
- (iii) Any component even with complex shape can be cast. There is no limit on the size of the component. Even large components can be cast.

The disadvantages of sand casting process are as follows :-

- (i) It is not possible to achieve close tolerances for cast components. Therefore, cast components require additional machining and finishing, which increases cost.
- (ii) Cast components have rough surface finish.
- (iii) Long and thin sections or projections are not possible for cast components.

One of the important deformation processes is forging. In forgings, the metal in the plastic stage, rather than in molten stage is forced to flow into the desired shape. There are number of forging processes such as hand forging, drop forging,

- (ii) It is not possible to machine thin sections or projections.
- (iii) There is wastage of material during material removal process.

In drilling operation, the cost of the hole increases linearly with the depth of the hole. However, when the depth is more than three times the diameter, the cost increases more rapidly.

In recent years, the trend is to bring design and manufacturing together as a single engineering discipline. It is called concurrent or simultaneous engineering. Concurrent engineering is defined as a process of designing a product considering all aspects simultaneously and early during design. These aspects include producibility, assembly, testability, installation, performance, reliability, maintainability, safety, cost and legal aspects. In concurrent engineering, manufacturing works simultaneously with design analysis and so on. Concurrent engineering has completely changed the philosophy and approach of engineering design.

## **1.12 AESTHETIC CONSIDERATIONS IN DESIGN**

Each product has a definite purpose. It has to perform specific functions to the satisfaction of customers. The contact between the product and the people arises due to the sheer necessity of this functional requirement. The functional requirement of an automobile car is to carry four passengers at a speed of 60 km/hr. There are people in cities, who want to go to their office at a distance of 15 km in fifteen minutes. So they purchase the car. The specific function of a domestic refrigerator is to preserve vegetables and fruits for a week. There is a housewife in the city, who cannot go to the market daily to purchase fresh vegetables. She will purchase the refrigerator. It is seen that the functional requirement brings product and people together.

However, when there are a number of products in the market, having the same qualities of efficiency, durability and cost, the customer is naturally attracted towards the most appealing product. The external appearance is an important feature, which gives grace and lustre to the product and dominates the market. This is particularly true for consumer durables like automobiles, household appliances and audio-visual equipment.

The growing realisation of the need of aesthetic considerations in product design has given rise to a separate discipline, known as industrial design. The job of an industrial designer is to create new forms and shapes which are aesthetically pleasing. The industrial designer has, therefore, become the fashion maker in hardware.

Like fashions, the outward appearance of the product has undergone many changes over the years. There are five basic forms—step, stream, taper, shear and sculpture. The step form is similar to the shape of a 'skyscraper' or multistorey building. This involves shapes with a vertical rather than a horizontal accent. The stream or streamline form is seen in automobiles and aeroplane structures. The taper form consists of tapered blocks interlocked with tapered plinths or cylinders.



The shear form has a square outlook, which is ideally suitable for free-standing engineering products. The sculpture form consists of ellipsoids, paraboloids and hyperboloids. The sculpture and stream forms are suitable for mobile products like vehicles, while step and shear forms for stationary products.

There is a relationship between functional requirement and appearance of a product. In many cases, functional requirements result in shapes which are aesthetically pleasing. The evolution of the streamlined shape of the boeing is the result of studies in aero-dynamics for effortless speed. The robust outlook and sound proportions of a high capacity hydraulic press are the results of requirements like rigidity and strength. The chromium plating of number of parts of household appliances is for the purpose of corrosion resistance rather than for pleasing appearance.

Selection of proper colour is an important consideration in product aesthetics. The choice of colour should be compatible with the conventional ideas of the operator. Many colours are associated with different moods and conditions. Morgan has suggested the meaning of colours in the following Table 1.4.

**Table 1.4**

<i>Colour</i>	<i>Meaning</i>
Red	Danger-Hazard-Hot
Orange	Possible danger
Yellow	Caution
Green	Safety
Blue	Caution-Cold
Grey	Dull

The external appearance of the product does not depend upon only two factors-form and colour. It is a cumulative effect of number of factors such as rigidity and resilience, tolerances and surface finish, motion of individual components, materials and manufacturing methods and noise. The industrial designer should select a form, which is in harmony with the functional requirements of the product. The economics and availability of surface treating processes like anodising, plating, blackening and painting should be taken into account before finalising the external appearance of the product.

### **1.13 ERGONOMIC CONSIDERATIONS IN DESIGN**

Ergonomics is defined as the relationship between man and machine and the application of anatomical, physiological and psychological principles to solve the problems arising from man-machine relationship. The word 'ergonomics' is coined from two greek words-ergon = work and nomos = natural laws. Ergonomics means the natural laws of work. From design considerations, the topics included in ergonomic studies are as follows:

- (i) Anatomical factors in design of driver's seat,

- (ii) Layout of instrument dials and display panels for accurate perception by the operators,
- (iii) Design of hand levers and hand wheels,
- (iv) Energy expenditure in hand and foot operations, and
- (v) Lighting, noise and climatic conditions in machine environment.

Ergonomists have carried out experiments to determine the best dimensions of driver's seat, the most convenient hand or foot pressure or dimensions of levers and hand wheels.

The machine is considered as an entity in itself in machine design. However, ergonomists consider man-machine joint system, forming a closed loop as shown in Fig. 1.7. From display instruments, the operator gets the information about the operations of the machine. If he feels that a correction is necessary, he will operate the levers or controls. This in turn will alter the performance of the machine which will be indicated on display panels. The contact between man and machine in this closed-loop system arises at two places—display instruments, which give information to the operator and controls, with which the operator adjusts the machine.

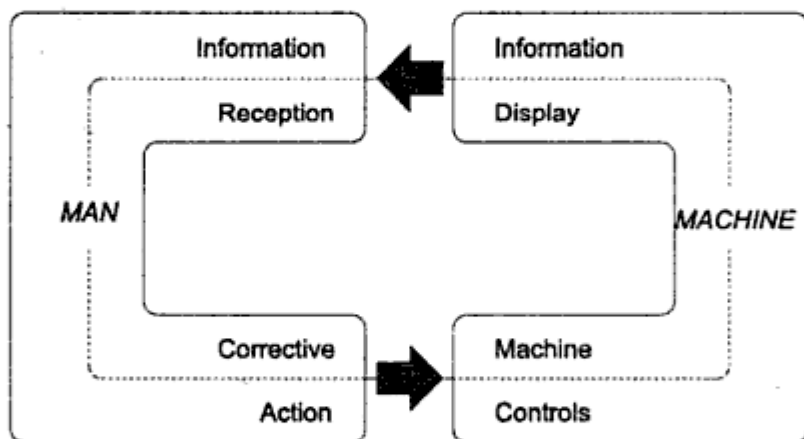

Fig. 1.7 Man Machine Closed Loop System

The visual display instruments are classified into three groups:

- (i) Displays giving quantitative measurements, such as speedometer, voltmeter or energymeter,
- (ii) Displays giving the state of affairs, such as the red lamp indicator, and
- (iii) Displays indicating predetermined settings, e.g. a lever which can be set at 1440 rpm, 720 rpm or 'off' position for a two-speed electric motor.

Moving scale or dial-type instruments are used for quantitative measurements, while lever-type indicators are used for setting purposes. The basic objective behind the design of displays is to minimise fatigue to operator, who has to observe them continuously. The ergonomic considerations in design of displays are as follows:

- (i) The scale on the dial indicator should be divided in suitable numerical progression like 0-10-20-30 and not 0-5-30-55.

- (ii) The number of sub-divisions between numbered divisions should be minimum.
- (iii) The size of letters or numbers on the indicator should be as follows:  

$$\text{Height of letter or number} \geq \frac{\text{reading distance}}{200}$$
- (iv) Vertical figures should be used for stationary dials, while radially oriented figures are suitable for rotating dials.
- (v) The pointer should have a knife-edge with a mirror in the dial to minimise parallax error.

The controls used to operate the machines consist of levers, cranks, handwheels, knobs, switches, push buttons and pedals. Most of them are hand operated. When a large force is required to operate the controls, levers and hand wheels are used. When the operating forces are light, push buttons or knobs are preferred. The ergonomic considerations in design of controls are as follows:

- (i) The controls should be easily accessible and logically positioned. The control operation should involve minimum motions and avoid awkward movements.
- (ii) The shape of the control component, which comes in contact with hands, should be in conformity with the anatomy of human hands.
- (iii) Proper colours produce psychological effects. The controls should be painted in red colour in grey background of machine tools to call for attention.

The aim of ergonomics is to reduce the operational difficulties present in man-machine joint system and to thereby decrease the resulting physical and mental stresses.

---

### **Review Questions**

---

1.1 Answer the following:

- (a) Define following terms:
  - (i) Machine                      (ii) Mechanism                      (iii) Structure.
- (b) What is the function of machine?
- (c) 'A machine transforms and transfers energy' Give any two examples to justify the statement.
- (d) What is the function of mechanism?
- (e) Distinguish between machine and mechanism.
- (f) Give any two examples of mechanism.
- (g) What is the function of structure?  
Give any two examples of structure.
- (h) Distinguish between machine and structure.

1.2 (a) What is 'machine design'?

- (b) Explain the basic procedure of machine design.

- 1.7 Answer the following:
- (a) Define standardisation.
  - (b) Give any four examples of the standards used in the design office.
  - (c) Distinguish between standard and code. What are their objectives?
  - (d) What are preferred numbers?  
How will you find numbers belonging to R10 series?
  - (e) State the advantage of preferred numbers.
- 1.8 (a) What are the basic elements of the cost of a product ?
- (b) Compare:
    - (i) fixed and variable costs,
    - (ii) direct and indirect costs, and
    - (iii) recurring and non-recurring costs.
  - (c) How will you decide the economic lot size of the production of a product ? Explain it with the help of break - even analysis.
  - (d) Explain any three guidelines to reduce the cost of the product.
- 1.9 (a) Name the machine components which are manufactured by following processes:
- (i) casting,
  - (ii) forging, and
  - (iii) machining.
- (b) Distinguish between casting, deformation and metal removal processes. Give their examples.
  - (c) Name any five factors that are to be considered while selecting the manufacturing method for the machine part.
  - (d) State the advantages and disadvantages of following processes as manufacturing methods:
    - (i) casting,
    - (ii) forging, and
    - (iii) machining.
  - (e) State the relationship between cost of drilled hole and the depth of hole.
  - (f) What is concurrent engineering ?
  - (g) Name the manufacturing method for following machine elements:
    - (i) shaft,
    - (ii) key,
    - (iii) power screw,
    - (iv) bolt and nut,
    - (v) helical spring,
    - (vi) lever, and
    - (vii) cylinder.
- 1.10 (a) Explain the importance of aesthetic considerations in machine design.
- (b) What is the relationship between the functional requirement and the appearance of a product?

# Properties of Engineering Materials

## 2.1 STRESS-STRAIN DIAGRAMS

A very useful information concerning the behaviour of material and its usefulness for engineering applications can be obtained by making tensile test and plotting a curve showing the variation of stress with respect to strain. Tensile test is one of the simplest and basic tests and determines values of number of parameters concerned with mechanical properties of materials like strength, ductility and toughness. Following information can be obtained from tensile test:

- (i) Proportional limit,
- (ii) Elastic limit,
- (iii) Modulus of elasticity,
- (iv) Yield strength,
- (v) Ultimate tensile strength,
- (vi) Modulus of resilience,
- (vii) Modulus of toughness,
- (viii) Percentage elongation, and
- (ix) Percentage reduction in area.

The specimen used in tension test is illustrated in Fig. 2.1. The shape and dimensions of this specimen are standardised. They should conform to I.S. 1608: 1972<sup>1</sup>. The cross-section of the specimen can be circular, square or rectangular. The standard gauge length  $l_0$  is given by,

$$l_0 = 5.65 \sqrt{A_0}$$

where  $A_0$  is the cross-sectional area of the specimen.

For circular cross-section,

$$l_0 = 5d_0$$

1. I.S. 1608, 1972: *Method for tensile testing of steel products.*

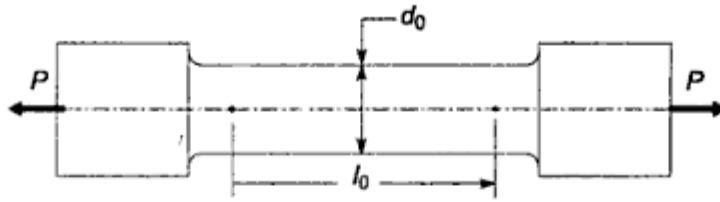

Fig. 2.1 Specimen of Tension-test

In tensile test, the specimen is subjected to axial tensile force which is gradually increased and corresponding deformation is measured. Initially, the gauge length is marked on the specimen and initial dimensions  $d_0$  and  $l_0$  are measured before starting the test. The specimen is then mounted on the machine and gripped in the jaws. It is then subjected to axial tensile force which is increased by suitable increments. After each increment, the amount by which the gauge length  $l_0$  increases, i.e. deformation of gauge length, is measured by an extensometer. The procedure of measuring the tensile force and corresponding deformation is continued till fracture occurs and the specimen is broken into two pieces. The tensile force divided by the original cross-sectional area of the specimen gives stress, while the deformation divided by gauge length gives the strain in the specimen.

Therefore, the results of tensile test are expressed by means of stress-strain relationship and plotted in the form of a graph. A typical stress-strain diagram for ductile materials like mild steel is shown in Fig. 2.2. Following properties of material can be obtained from this diagram:

(i) **Proportional limit** It is observed from the diagram that stress-strain relationship is linear from point  $O$  to  $P$ .  $OP$  is a straight line and after point  $P$ , the curve begins to deviate from the straight line. Hooke's law states that stress is

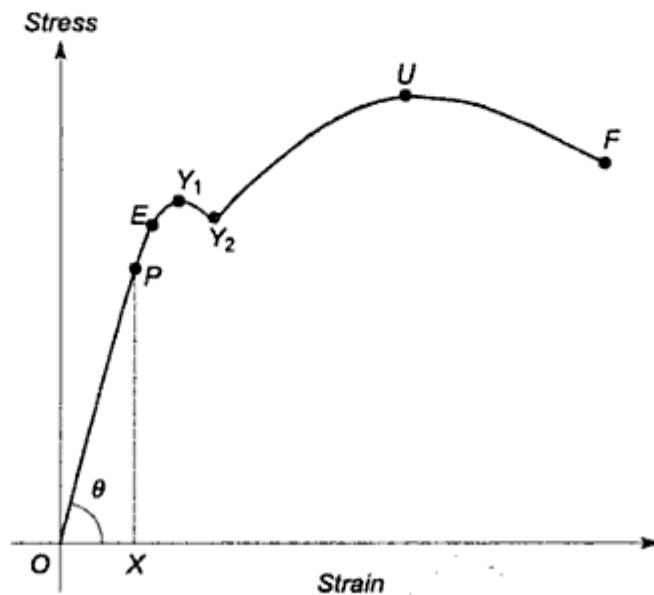

Fig. 2.2 Stress-strain Diagram of Ductile Materials

directly proportional to strain. Therefore, it is applicable only upto point  $P$ . The term proportional limit is defined as the stress at which the stress-strain curve begins to deviate from the straight line. Point  $P$  indicates the proportional limit.

**(ii) Modulus of elasticity** The modulus of elasticity or Young's modulus ( $E$ ) is the ratio of stress to strain upto point  $P$ . It is given by the slope of line  $OP$ . Therefore,

$$E = \tan \theta = \frac{PX}{OX} = \frac{\text{stress}}{\text{strain}}$$

**(iii) Elastic limit** Even if the specimen is stressed beyond point  $P$  and upto point  $E$ , it will regain its initial size and shape when the load is removed. This indicates that the material is in elastic stage up to point  $E$ . Therefore,  $E$  is called elastic limit. The elastic limit of the material is defined as the maximum stress without any permanent deformation.

The proportional limit and elastic limit are very close to each other and it is difficult to distinguish between points  $P$  and  $E$  on the stress-strain diagram. In practice, many times, these two limits are taken to be equal.

**(iv) Yield strength** When the specimen is stressed beyond point  $E$ , plastic deformation occurs and material starts yielding. During this stage, it is not possible to recover the initial size and shape of the specimen on the removal of the load. It is seen from the diagram that beyond point  $E$ , the strain increases at a faster rate up to point  $Y_1$ . In other words, there is an appreciable increase in strain without much increase in stress. In case of mild steel, it is observed that there is small reduction in load and the curve drops down to point  $Y_2$  immediately after yielding starts. The points  $Y_1$  and  $Y_2$  are called upper and lower yield points respectively. For many materials, the points  $Y_1$  and  $Y_2$  are very close to each other and in such cases, the two points are considered as same and denoted by  $Y$ . The stress corresponding to yield point  $Y$  is called yield strength. The yield strength is defined as the maximum stress at which a marked increase in elongation occurs without increase in the load.

Many varieties of steel, especially heat-treated steels and cold-drawn steels do not have a well defined yield point on the stress-strain diagram. As shown in Fig. 2.3, the material yields gradually after passing through elastic limit  $E$ . If the loading is stopped at point  $Y$ , at a stress level slightly higher than elastic limit  $E$ , and the specimen is unloaded and readings taken, the curve would follow the dotted line and a permanent set or plastic deformation will exist. The strain corresponding to this permanent deformation is indicated by  $OA$ . For such materials, which do not exhibit a well defined yield point, the yield strength is defined as the stress corresponding to a permanent set of 0.2% of gauge length. In such cases, the yield strength is determined by offset method. A distance  $OA$  equal to 0.002 mm/mm strain (corresponding to 0.2% of gauge length) is marked on  $X$  axis. A line is constructed from point  $A$  parallel to straight line portion  $OP$  of the stress-strain curve. The point of intersection of this line and the stress-strain

curve is called  $Y$  or the yield point and the corresponding stress is called 0.2% yield strength.

The terms proof load or proof strength are frequently used in design of fasteners. The proof strength is similar to yield strength. It is determined by offset method, however the offset in this case is 0.001 mm/mm corresponding to a permanent set of 0.1% of gauge length. 0.1% proof strength, denoted by symbol  $R_{p0.1}$  is defined as the stress which will produce a permanent extension of 0.1% in the gauge length of the test specimen. The proof load is the force corresponding to proof stress.

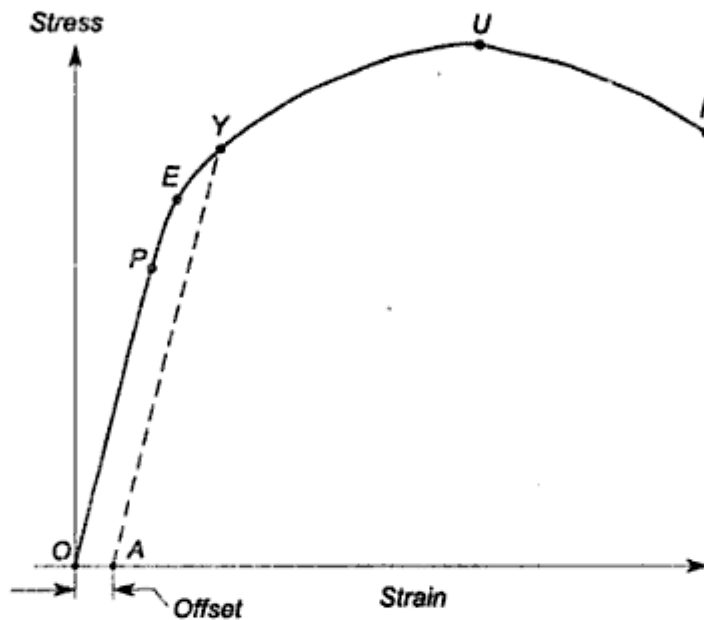

Fig. 2.3 Yield Stress by Offset Method

(v) **Ultimate tensile strength** We will refer back to stress-strain diagram of ductile materials illustrated in Fig. 2.2. After the yield point  $Y_2$ , plastic deformation of the specimen increases. The material becomes stronger due to strain hardening and higher and higher load is required to deform the material. Finally the load and corresponding stress reaches a maximum value, as given by point  $U$ . The stress corresponding to point  $U$  is called ultimate strength. The ultimate tensile strength is the maximum stress that can be reached in the tension test.

For ductile materials, the diameter of the specimen begins to decrease rapidly beyond maximum load point  $U$ . There is localised reduction in cross-sectional area called 'necking'. As the test progresses, the cross-sectional area at the neck decreases rapidly and fracture takes place at the narrowest cross-section of the neck. This fracture is shown by point  $F$  on the diagram. The stress at the time of fracture is called breaking strength. It is observed from stress-strain diagram that there is a downward trend after the maximum stress has been reached. The breaking strength is slightly lower than ultimate tensile strength.



$$\text{Percentage reduction in area} = \left( \frac{A_0 - A}{A_0} \right) \times 100$$

where,

$A_0$  = original cross-sectional area of test specimen.

$A$  = final cross-sectional area after fracture.

Percentage reduction in area, like percentage elongation, is a measure of the ductility of the material. If porosity or inclusions are present in the material or if damage due to overheating the material has occurred, the percentage elongation as well as percentage reduction in area is drastically decreased. Therefore, percentage elongation or percentage reduction in area is considered as an index of quality for the material.

## 2.2 MECHANICAL PROPERTIES OF ENGINEERING MATERIALS

Materials are characterised by their properties. They may be hard, ductile or heavy. Conversely, they may be soft, brittle or light. The mechanical properties of materials are the properties which describe the behaviour of the material under the action of external forces. They usually relate to elastic and plastic behaviour of the material. Mechanical properties are of significant importance in selection of material for structural machine component. In this article, we will consider following mechanical properties:

- |                |               |                 |              |
|----------------|---------------|-----------------|--------------|
| 1. strength    | 2. elasticity | 3. plasticity   | 4. stiffness |
| 5. resilience  | 6. toughness  | 7. malleability | 8. ductility |
| 9. brittleness | 10. hardness. |                 |              |

**Strength** is defined as the ability of the material to resist, without rupture, external forces causing various types of stresses. Strength is measured by different quantities. Depending upon the type of stresses induced by external loads, strength is expressed as tensile strength, compressive strength or shear strength. Tensile strength is the ability of the material to resist external load causing tensile stress, without fracture. Compressive strength is the ability to resist external load that causes compressive stress, without failure. The terms yield strength and ultimate tensile strength are explained in the previous article.

**Elasticity** is defined as the ability of the material to regain its original shape and size after the deformation, when the external forces are removed. All engineering metals are elastic but the degree of elasticity varies. Steel is perfectly elastic within elastic limit. The amount of elastic deformation which a metal can undergo is very small. During the elastic deformation, the atoms of metal are displaced from their original positions but not to the extent that they take up new positions. Therefore, when the external force is removed, the atoms of metal return to their original positions and the metal takes back its original shape.

**Plasticity** is defined as the ability of the material to retain the deformation produced under the load on permanent basis. In this case, the external forces

Charpy impact testing machines. Toughness decreases as the temperature increases. The difference between resilience and toughness is as follows:

- (i) Resilience is the ability of the material to absorb energy within elastic range. Toughness is the ability to absorb energy within elastic and plastic range.
- (ii) Modulus of resilience is the area below stress-strain curve in tension test upto yield point. Modulus of toughness is the total area below stress-strain curve.
- (iii) Resilience is essential in spring applications while toughness is required for components subjected to bending, twisting, stretching or to impact loads. Spring steels are resilient while structural steels are tough.

Figure 2.6(a) and (b) shows the difference between moduli of resilience and toughness.

**Malleability** is defined as the ability of the material to deform to a greater extent before the sign of crack, when it is subjected to compressive force. The term malleability comes from a word meaning 'hammer' and in a narrow sense, means the ability to be hammered out into thin sections. Malleable metals can be rolled, forged or extruded because these processes involve shaping under compressive force. Low carbon steels, copper and aluminium are malleable metals. In general, malleability increases with temperature. Therefore, processes like forging or rolling are hot working processes where hot ingots or slabs are given a shape.

**Ductility** is defined as the ability of the material to deform to a greater extent before the sign of crack, when it is subjected to tensile force. In other words, ductility is the permanent strain that accompanies fracture in tension test. Ductile materials are those materials which deform plastically to a greater extent prior to fracture in tension test. Mild steel, copper and aluminium are ductile materials. Ductile metals can be formed, drawn or bent because these processes involve shaping under tension. Ductility is a desirable property in machine components which are subjected to unanticipated overloads or impact loads. Ductility is measured in units of percentage elongation or percentage reduction in area in

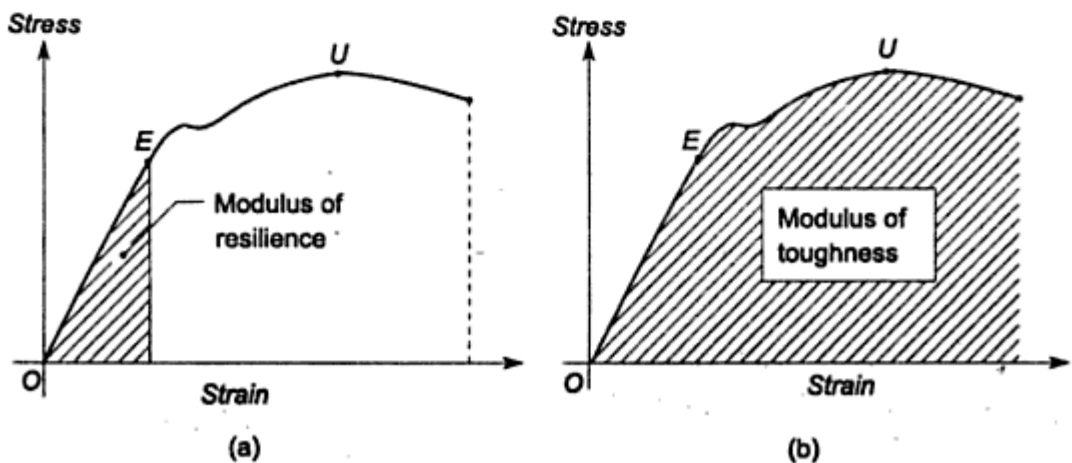

Fig. 2.6 Moduli of Resilience and Toughness

tension test. The ductility of metal decreases as the temperature increases because metals become weak at increasing temperature<sup>2</sup>. All ductile materials are also malleable, however, the converse is not always true. Some metals are soft but weak in tension and therefore, tend to tear apart under tension. Both malleability as well as ductility are reduced by presence of impurities in the material. The difference between malleability and ductility is as follows:

- (i) Malleability is the ability of the material to deform under compressive force. Ductility is the ability to deform under tensile force.
- (ii) Malleability increases with temperature while ductility decreases with increasing temperature.
- (iii) All ductile materials are also malleable, but the converse is not true.
- (iv) Malleability is important property when the component is forged, rolled or extruded. Ductility is desirable when the component is formed or drawn. It is also desirable when the machine component is subjected to shock loads.

**Brittleness** is that property of the material which shows negligible plastic deformation before fracture takes place. Brittleness is opposite property to ductility. A brittle material is that, which undergoes little plastic deformation prior to fracture in tension test. Cast iron is an example of brittle material. In ductile materials, failure takes place by yielding. Brittle components fail by sudden fracture. A tensile strain of 5% at fracture in tension test is considered as the dividing line between ductile and brittle materials. The difference between ductility and brittleness is as follows:

- (i) Ductile materials deform to a greater extent before fracture in tension test. Brittle materials show negligible plastic deformation prior to fracture.
- (ii) Steels, copper and aluminium are ductile materials while cast iron is brittle.
- (iii) The energy absorbed by ductile specimen before fracture in tension test is more, while brittle fracture is accompanied by negligible energy absorption.
- (iv) In ductile materials, failure takes place by yielding which is gradual. Brittle materials fail by sudden fracture.

**Hardness** is defined as the resistance of the material to penetration or permanent deformation. It usually indicates resistance to abrasion, scratching, cutting or shaping. Hardness is an important property in selection of material for parts which rub on one another such as pinion and gear, cam and follower, rail and wheel and parts of ball bearing. Wear resistance of these parts is improved by increasing surface hardness by case hardening. There are four primary methods of measuring hardness-*Brinell hardness test*, *Rockwell hardness test*, *Vicker hardness test* and *Shore scleroscope*. In the first three methods, an indenter is pressed onto the surface under a specific force. The shape of the indenter is either a ball, pyramid or cone. The indenters are made of diamond, carbide or hardened

2. Raymond A Higgins, *Materials for the engineering technician*, Edward Arnold, UK, 1987.

steel, which are much more harder than the surface being tested. Depending upon the cross-sectional area and depth of indentation, hardness is expressed in the form of an empirical number like Brinell hardness number. In Shore scleroscope, height of rebound from the surface being tested indicates the hardness. Hardness test is simpler than tension test. It is non-destructive because a small indentation may not be detrimental to the performance of the product. Hardness of the material depends upon the resistance to plastic deformation. Therefore, as the hardness increases, the strength also increases. For certain metals like steels, empirical relationships between strength and hardness are established. For steels,

$$S_{ut} = 3.45 (\text{BHN})$$

where  $S_{ut}$  is ultimate tensile strength in  $\text{N/mm}^2$ .

### 2.3 CREEP

When a component is under a constant load, it may undergo progressive plastic deformation over a period of time. This time-dependent strain is called creep. Creep is defined as slow and progressive deformation of the material with time under a constant stress. Creep deformation is a function of stress level and temperature. Therefore, creep deformation is higher at higher temperature and creep becomes important for components operating at elevated temperatures. Creep of bolts and pipes is a serious problem in thermal power stations. The material of steam or gas turbine blades should have a low creep rate, so that blades can remain in service for a long period of time before having to be replaced due to their reaching the maximum allowable strain. These blades operate with very close clearances and permissible deformation is important consideration in their design. Design of components working at elevated temperature is based on two criteria. Deformation due to creep must remain within permissible limit and rupture must not occur during the service life. Based on these two criteria, there are two terms—*creep strength* and *creep rupture strength*. *Creep strength* of the material is defined as the maximum stress that the material can withstand for a specified length of time without excessive deformation. *Creep rupture strength* of material is the maximum stress that the material can withstand for a specified length of time without rupture.

An idealised creep curve is shown in Fig.2.7. When the load is applied at the beginning of the creep test, the instantaneous elastic deformation  $OA$  occurs. This elastic deformation is followed by the creep curve  $ABCD$ . Creep occurs in three stages. The first stage called 'primary creep' is shown by  $AB$  on the curve. During this stage, the creep rate i.e. the slope of creep curve from  $A$  to  $B$  progressively decreases with time. The metal strain hardens to support the external load. The creep rate decreases because further strain hardening becomes more and more difficult. The second stage called 'secondary creep' is shown by  $BC$  on the curve. During this stage, the creep rate is constant. This stage occupies a major portion of the life of the component. Designer is mainly concerned with this stage. During

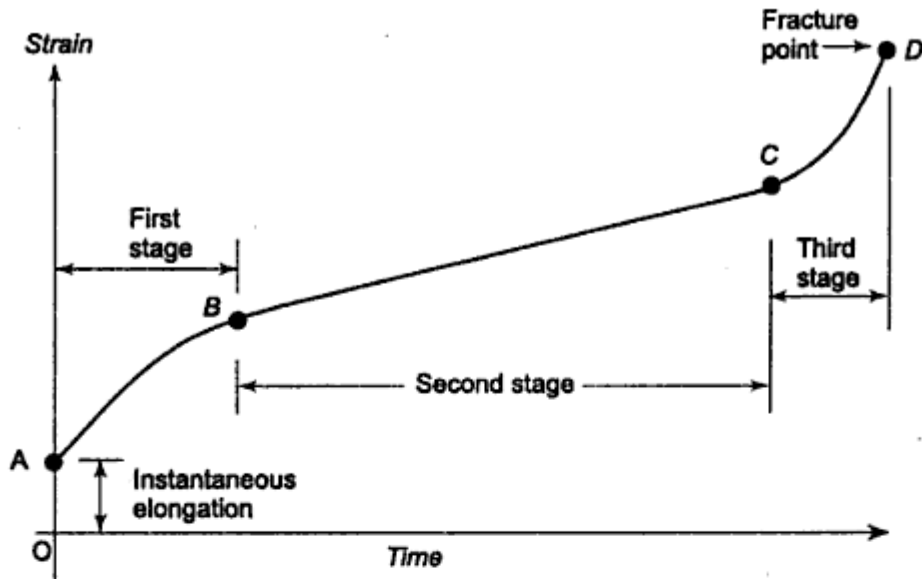

Fig. 2.7 Creep Curve

secondary creep, recovery processes involving highly mobile dislocations counteract the strain hardening so that the metal continues to elongate at constant rate<sup>3</sup>. The third stage called 'tertiary creep' is shown by  $CD$  on the creep curve. During this stage the creep rate is accelerated due to necking and also due to formation of voids along the grain boundaries. Therefore, creep rate rapidly increases and finally results in fracture at point  $D$ . Creep properties are determined by experiments and these experiments involve very long periods stretching into months.

## 2.4 STRESS CONCENTRATION

In design of machine elements, following three fundamental equations are used,

$$\sigma_t = \frac{P}{A}$$

$$\sigma_b = \frac{M_b y}{I}$$

$$\tau = \frac{M_t r}{J}$$

The above equations are called 'elementary' equations. These equations are based on number of assumptions. One of the assumptions is that there are no discontinuities in the cross-section of the component. However, in practice, discontinuities and abrupt changes in cross-section are unavoidable due to certain features of the component such as oil holes and grooves, keyways and splines, screw threads and shoulders. Therefore, it cannot be assumed that the cross-

3. William F Smith, *Principles of materials science and engineering*, McGraw Hill Pub. Co., 1990.

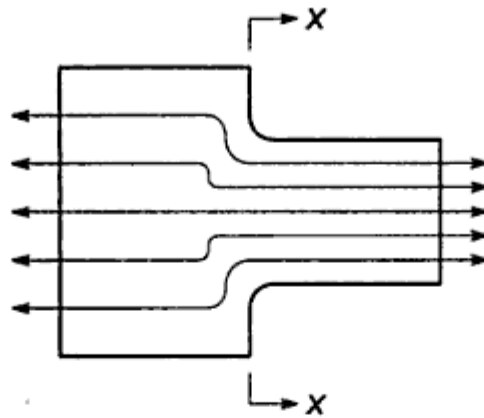

Fig. 2.10 Force Flow Lines

flow lines are parallel indicating uniform distribution of stresses. At the right end, they are closer together indicating higher magnitude of stress. At the left end, they are spaced comparatively away from each other, indicating lower magnitude of stress. When these lines from left and right sides join at section XX, they are bent indicating weakening of the material.

The stress distribution in above two examples varies from one end to the other. There are two terms—normal stresses and localised stresses—used in this connection. Normal stresses are shown at the two ends with uniform distribution. The localised stresses are restricted to local regions of the component such as sections of discontinuity. The difference between normal and localised stresses is as follows:

- (i) Normal stresses are stresses in the machine component at a section away from discontinuity or abrupt change of cross-section. The localised stresses are stresses in the local regions of the component such as the section of discontinuity or section of change of cross-section.
- (ii) Normal stresses are easily determined by 'elementary' equations. It is not possible to use these formulae for localised stresses. They are usually determined by experimental methods like photo-elasticity or by finite element method.
- (iii) The normal stresses are comparatively of small magnitude. The localised stresses in the vicinity of discontinuity are frequently of large magnitude and may give rise to a crack. Such a crack may propagate and lead to failure by fracture.
- (iv) Failure rarely occurs in region of normal stresses. The region of localised stresses is more vulnerable to fatigue failure.

A plate with a small circular hole, subjected to tensile stress is shown in Fig. 2.11. The distribution of stresses near the hole can be observed by keeping a model of the plate made of epoxy resin in circular polariscope. It is observed from the nature of stress distribution at the section passing through the hole, that there is sudden rise in the magnitude of stresses in the vicinity of the hole. The localised stresses in the neighbourhood of the hole are far greater than the stresses obtained

These variations act as discontinuities in the component and cause stress concentration.

(ii) *Load application:* Machine components are subjected to forces. These forces act either at a point or over a small area on the component. The pressure at these points, where the force acts is usually excessive and causes stress concentration. The examples of these load applications are as follows:

- (a) Contact between the meshing teeth of the driving and the driven gear,
- (b) Contact between the cam and the follower,
- (c) Contact between the balls and the races of ball bearing,
- (d) Contact between the rail and the wheel, and
- (e) Contact between the crane hook and the chain.

In all these cases, concentrated load is applied over a very small area resulting in stress concentration.

(iii) *Abrupt changes in section:* In order to mount gears, sprockets, pulleys and ball bearings on transmission shaft, steps are cut on the shaft and shoulders are provided from assembly considerations. Although, these features are essential, they result in changes in the cross-section of the shaft. There is stress concentration at these sections.

(iv) *Discontinuities in the component:* Certain features of machine components such as oil holes or oil grooves, keyways and splines, and screw threads result in discontinuities in the cross-section of the component. There is stress concentration in the vicinity of these discontinuities.

(v) *Machining scratches:* Machining scratches, stamp mark or inspection mark are surface irregularities which cause stress concentration.

Although it is not possible to eliminate the effect of stress concentration, there are methods to reduce stress concentrations. It was mentioned earlier that effect of stress concentration is proportional to the bending of the force flow lines. Therefore, stress concentration can be reduced by minimising the bending of the flow lines. This is achieved by providing specific geometric shape to the component. Reduction of stress concentration is achieved by following methods:

(i) *Additional notches and holes in tension member:* A flat plate with a V-notch subjected to tensile force is shown in Fig. 2.12 (a). It is observed that a single notch results in a high degree of stress concentration. The severity of stress concentration is reduced by three methods: (a) use of multiple notches, (b) drilling additional holes, and (c) removal of undesired material. These methods are illustrated in Fig. 2.12 (b), (c) and (d) respectively. The method of removing undesired material is called the principle of minimisation of the material. In these three methods, the sharp bending of force flow line is reduced and it follows a smooth curve.

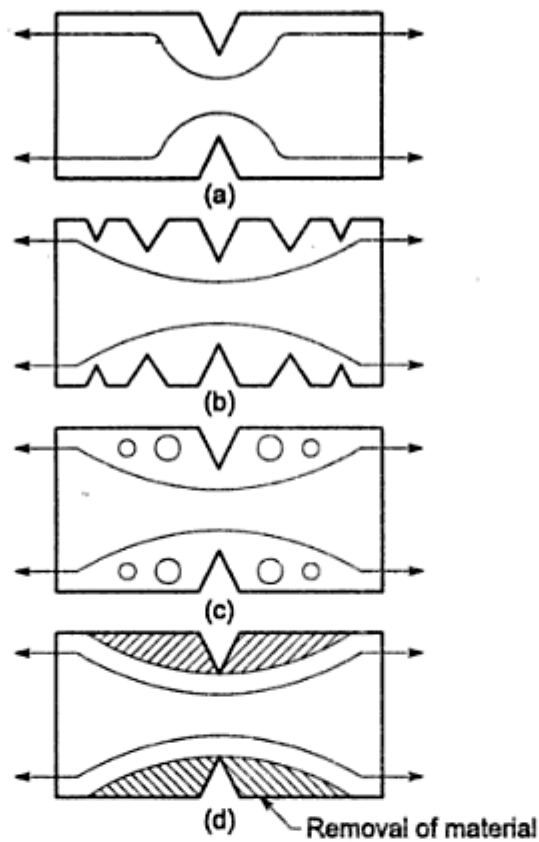

**Fig. 2.12** Reduction of Stress Concentration due to V-notch (a) Original Notch (b) Multiple Notches (c) Drilled Holes (d) Removal of Undesired Material

- (ii) *Fillet radius, undercutting and notch for member in bending:* A bar of circular cross-section with a shoulder, which is subjected to bending moment is shown in Fig. 2.13(a). For proper assembly, ball bearings, gears or pulleys have to be seated against this shoulder. The shoulder results in change of cross-section accompanied by stress concentration. There are three methods to reduce stress concentration at the base of the shoulder. Fig. 2.13(b) shows the shoulder with a fillet radius 'r'. This results in gradual transition from small diameter to large diameter. The fillet radius should be as large as possible in order to reduce stress concentration. In practice, fillet radius is limited by the design of mating components. The fillet radius can be increased by undercutting the shoulder as illustrated in Fig. 2.13(c). A notch results in stress concentration. Surprisingly, cutting an additional notch is effective way to reduce stress concentration. This is illustrated in Fig. 2.13(d).
- (iii) *Drilling additional holes for shaft:* A transmission shaft with a keyway is shown in Fig. 2.14(a). Keyway is a discontinuity and results in stress concentration at the corners of the key way and reduces torsional shear strength. An empirical relationship developed by H.F. Moore for the ratio 'C' of torsional strength of shaft having a keyway to torsional strength of same sized shaft without keyway is given by



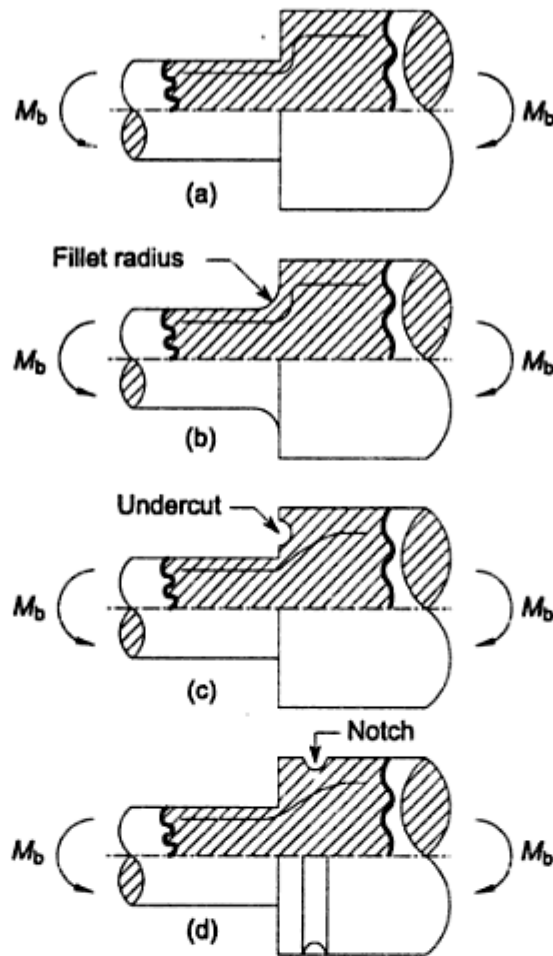
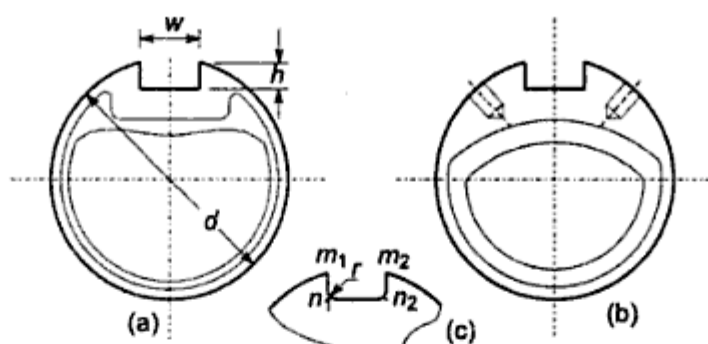

**Fig. 2.13** Reduction of Stress Concentration due to Abrupt Change in cross-section (a) Original Component (b) Fillet Radius (c) Undercutting (d) Addition of Notch

$$C = 1 - 0.2 \left( \frac{w}{d} \right) - 1.1 \left( \frac{h}{d} \right)$$

where 'w' and 'h' are width and height dimensions of the keyway respectively and 'd' is the shaft diameter. The four corners of the keyway, viz.  $m_1$ ,  $m_2$ ,  $n_1$  and  $n_2$  are shown in Fig. 2.14(c). It has been observed that torsional shear stresses at points  $m_1$  and  $m_2$  are negligibly small in practice and theoretically equal to zero. On the other hand, the torsional shear stresses at points  $n_1$  and  $n_2$  are excessive and theoretically infinite<sup>4</sup> which means even a small torque will produce permanent set at these points. The stress concentration can be reduced by rounding corners  $n_1$  and  $n_2$  by

4. S Timoshenko, *Strength of materials, Part II, Advanced theory and problems*, D. Van Nostrand Co. Inc., 1965.



**Fig. 2.14** Reduction of Stress Concentration in Shaft with Keyway  
 (a) Original Shaft (b) Drilled Holes (c) Fillet Radius

providing fillet radius. A stress concentration factor  $K_t = 3$  should be used when the shaft is subjected to combined bending and torsional moments.<sup>5</sup>

In addition to giving fillet radius at the inner corners of keyway, there is another method of drilling two symmetrical holes on the sides of keyway. These holes press the force flow lines and minimise their bending in the vicinity of the keyway. This method is illustrated in Fig. 2.14(b).

- (iv) *Reduction of stress concentration in threaded members:* A threaded component is shown in Fig. 2.15(a). It is observed that the force flow line is bent as it passes from shank portion to threaded portion of the component. This results in stress concentration in the transition plane. In Fig. 2.15(b), a small undercut is taken between the shank and the threaded portion of the component and fillet radius is provided for this undercut. This reduces bending of the force flow line and consequently reduces stress concentration. An ideal method to reduce stress concentration is illustrated in Fig. 2.15(c), where the shank diameter is reduced and made equal to the core diameter of the thread. In this case, the force flow line is almost straight and there is no stress concentration.

Many discontinuities found in machine components cannot be avoided. Therefore, stress concentration cannot be totally eliminated. However, it can be greatly reduced by selecting the correct geometric shape by the designer. Many difficult problems involving stress concentration have solved by removing material instead of adding it. Additional notches, holes and undercuts are the simple means to achieve significant reduction in stress concentration.

## 2.5 STATIC AND DYNAMIC LOADS

Machine components are subjected to external force or load. The external load acting on the component is either *static* or *dynamic*. The dynamic load is further

5. JE Shigley and Mitchell LD, *Mechanical Engineering Design*, McGraw-Hill Inc, 1983.

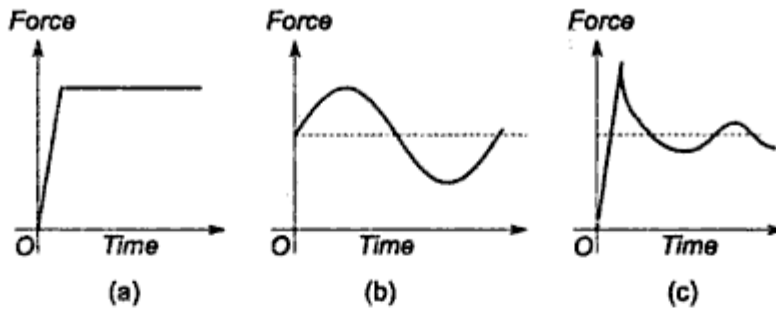

Fig. 2.16 Types of Load (a) Static Load (b) Cyclic Load (c) Impact Load

- (ii) The examples of static loads are dead weights of machinery, tightening-up load on bolts and fasteners and load acting on the walls and cover of a pressure vessel subjected to constant pressure. The examples of cyclic loads are forces induced in gear teeth, loads induced in a rotating shaft subjected to bending moment or forces acting on the compression spring of the valves in internal combustion engines. An impact load results from contact between a moving component and another component or by large accelerations, such as centrifugal bursting of a rotating flywheel. A punch press or rivet gun are examples of machines subjected to impact loads.
- (iii) When a component is subjected to static load, two types of mechanical failures may occur—yielding and fracture. The failure due to yielding consists of a large amount of plastic deformation after the yield point is reached. A machine component loses its usefulness due to this plastic deformation. Yielding is restricted to components made of ductile materials. Components made of brittle material fail by sudden fracture without any plastic deformation. Materials, when subjected to cyclic loads, behave differently than when they are subjected to static loads. Failure may occur when the load cycles are repeated several million times, even though the stress is below the elastic limit. The failure begins with a crack, which occurs at a highly stressed point in the component. The crack grows during the cycles and failure occurs suddenly without any indication. This type of failure is called fatigue failure. A fatigue failure is a progressive fracture starting from a point in the area of stress concentration and leading to ultimate fracture. The fracture due to impact load may be either brittle or ductile<sup>6</sup>. The brittle fracture is not accompanied by noticeable plastic deformation. It has bright granular or crystalline appearance. Considerable plastic deformation takes place in a ductile fracture and the fractured surface has dull-grey fibrous appearance.
- (iv) It is comparatively easy to determine static load and design a component on the basis of static load. In practice, the pattern of stress variation due to dynamic loads is irregular and unpredictable. It is difficult to design a

6. BK Agrawal, *Introduction to engineering materials*, Tata McGraw Hill Pub. Co. Ltd., 1989.

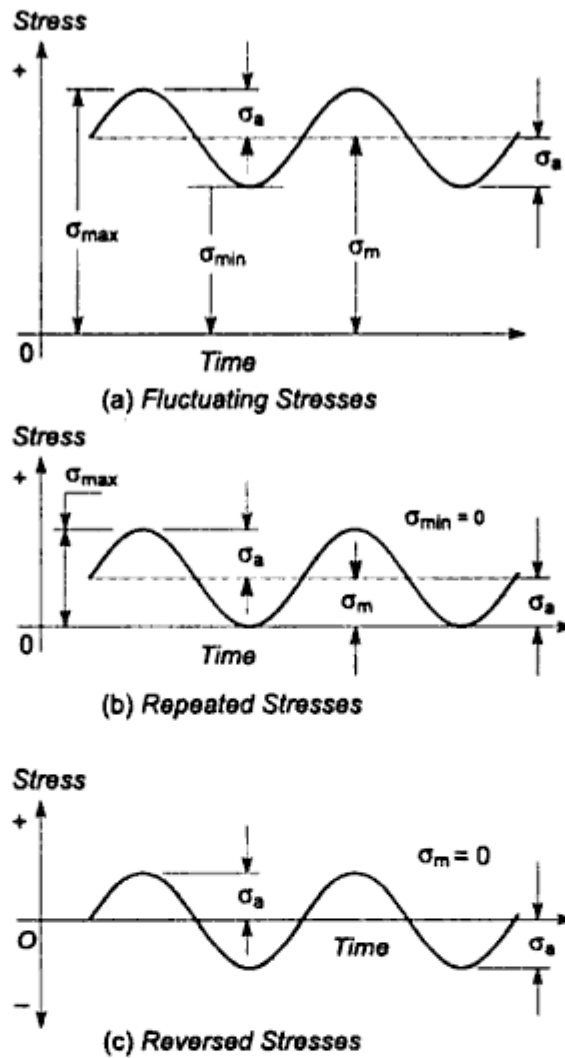
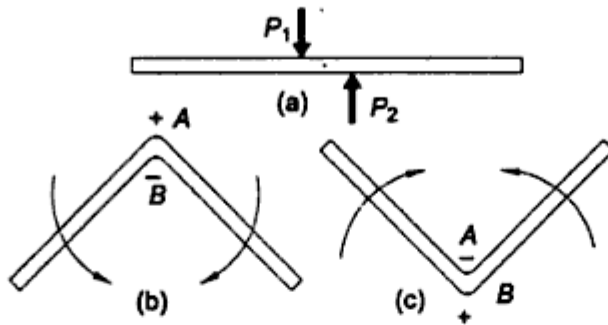

Fig. 2.17 Types of Cyclic Stresses

of 2 to 3 mm diameter and we want to cut it into two pieces without any device like saw. One method is to shear the wire by applying equal and opposite forces  $P_1$  and  $P_2$  by left and right hands as illustrated in Fig. 2.18(a). It is difficult to cut the wire by this method. Second method consists of alternatively bending and unbending the wire for few cycles. Let us consider two diametrically opposite points  $A$  and  $B$  on the surface of the wire. As shown in Fig. 2.18(b), when the wire is bent,  $A$  is subjected to tensile stress while  $B$  to compressive stress. When the wire is unbent, there is compressive stress at  $A$  and tensile stress at  $B$ , as shown in Fig. 2.18(c). Therefore, there is complete reversal of stress from tensile stress to compressive stress at point  $A$  due to alternate bending and unbending. Similarly, point  $B$  is subjected to reversal of stress from compressive stress to tensile stress during the same cycle. We have experienced that the wire can be cut very easily in few cycles of bending and unbending. This is a fatigue failure and the magnitude of stress required to fracture is very low. In other words, there is decreased resistance of material to cyclic stresses. Fatigue failure is defined as

time delayed fracture under cyclic loading<sup>7</sup>. Examples of parts in which fatigue failures are common are transmission shafts, connecting rods, gears, vehicle suspension springs and ball bearings.



**Fig. 2.18** Shear and Fatigue Failure of Wire (a) Shearing of Wire (b) Bending of Wire (c) Unbending of Wire

There is a basic difference between failure due to static load and that due to fatigue. The failure due to static load is observed in tension test. In tension test, the load is gradually applied and there is sufficient time for the elongation of fibres. In case of ductile materials, there is considerable plastic deformation prior to fracture. There are three distinct stages of ductile fracture which are illustrated in Fig. 2.19(a), (b) and (c) respectively. They are as follows:

- (i) The specimen forms a neck and cavities are formed within the neck region,
- (ii) The cavities in the neck coalesce into a crack in the centre of the specimen and propagate towards the surface of the specimen in a direction perpendicular to the applied load, and
- (iii) When the crack reaches the surface, the direction of crack changes to  $45^\circ$  to the tensile force acting on the specimen and a cup and cone fracture results<sup>8</sup>.

In this case, due to stretching of crystals, the fractured surface has silky fibrous structure.

The fatigue failure begins with a crack at some point in the component.

The crack is more likely to occur in the following regions:

- (i) Regions of discontinuity such as oil holes or keyways,
- (ii) Regions of abrupt change in cross-section such as shoulder or steps,
- (iii) Regions of irregularities in machining operations such as machining scratches, stamp mark or inspection marks, and
- (iv) Internal cracks in materials like blow holes.

These regions are subjected to stress concentration due to presence of crack. The crack propagates with increasing number of stress cycles. A component with

7. Lawrence H Van Vlack, *Elements of materials science and engineering*, Addison, Wesley Pub. Co., 1985.

8. George E Dieter, *Mechanical Metallurgy*, McGraw-Hill Book Co., 1986

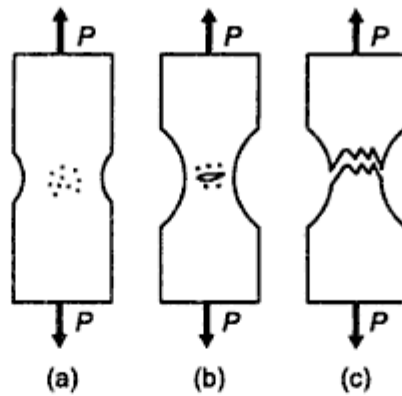
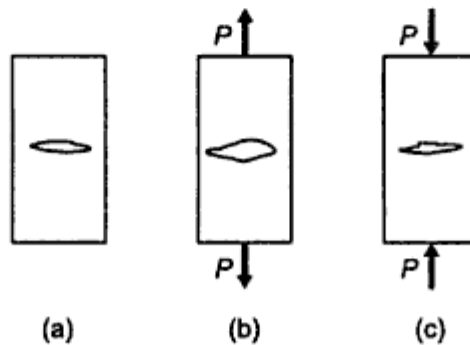

**Fig. 2.19** Stages of Ductile Fracture under Static Load (a) Formation of Neck and Cavities, (b) Formation of Crack, and (c) Cup and Con Fracture

a crack, which is subjected to alternate tensile and compressive stresses, is shown in Fig. 2.20. During first half of the cycle, the stress is tensile and the crack opens. During the second half of the cycle, there is compressive stress and crack closes. This opening and closing of the crack during each cycle continues and results in crack propagation. Finally, the cross-section of the component is so reduced that the remaining portion is no longer in a position to sustain the external force and it is subjected to sudden fracture. There are two distinct areas on the fractured surface of the component. They are as follows:

- (i) A smooth surface area with fine fibrous appearance indicating slow growth of crack, and
- (ii) A rough surface area with coarse granular appearance indicating sudden fracture.

In case of failure under static load, there is always sufficient plastic deformation prior to failure, which gives advance warning of likely fracture. Plastic deformation occurs in fatigue, but it is highly localised. Therefore, fatigue failure occurs without the warning of gross plastic deformation. Fatigue cracks are not visible till they reach the surface of the component and by that time the failure has already occurred. The fatigue failure is sudden and total. It is relatively easy to design a component subjected to static load. The fatigue failure depends



**Fig. 2.20** Crack Propagation: (a) Component with Crack, (b) Opening of Crack (Tensile Half), and (c) Closing of Crack (Compressive Half)

upon a number of factors, such as number of cycles, mean stress, stress amplitude, stress concentration, residual stresses, corrosion and creep. This makes the design of components subjected to cyclic stresses more complex.

## 2.8 ENDURANCE LIMIT

The fatigue or endurance limit of a material is defined as the maximum amplitude of completely reversed stress that the standard specimen can sustain for an unlimited number of cycles without fatigue failure. Since the fatigue test cannot be conducted for unlimited or infinite number of cycles,  $10^6$  cycles is considered as a sufficient number of cycles to define the endurance limit. There is another term called fatigue life which is frequently used with endurance limit. The fatigue life is defined as the number of stress cycles that the standard specimen can complete during the test before the appearance of the first fatigue crack. The dimensions of standard test specimen (in mm) are shown in Fig. 2.21. The specimen is carefully machined and polished. The final polishing is done in axial direction in order to avoid circumferential scratches. In laboratory, the endurance limit is determined by means of a rotating beam machine developed by RR Moore. The principle of rotating beam is illustrated in Fig. 2.22. A beam of circular cross-section is subjected to bending moment  $M_b$ . Under the action of bending moment, tensile stresses are induced in the upper half of the beam and compressive stresses in the lower half. The maximum tensile stress  $\sigma_t$  in the uppermost fibre is equal to the maximum compressive stress  $\sigma_c$  in the lowermost fibre. There is zero stress at all fibres in the central horizontal plane passing through the axis of the beam. Let us consider a point A on the surface of the beam and let us try to find out stresses at this point when the shaft is rotated through one revolution. Initially point A occupies position  $A_1$  in the central horizontal plane with zero stress. When the shaft is rotated through  $90^\circ$ , it occupies position  $A_2$ . It is subjected to maximum tensile stress  $\sigma_t$  in this position. When the shaft is further rotated through  $90^\circ$ , point A will occupy position  $A_3$  in the central horizontal plane with zero stress. A further rotation of  $90^\circ$  will bring point A to position  $A_4$ . It is subjected to maximum compressive stress  $\sigma_c$  in this position. The variation of stresses at point A during one revolution of the shaft is shown in Fig. 2.22(b). It is observed that the beam is subjected to completely reversed stresses with tensile stress in the first half and

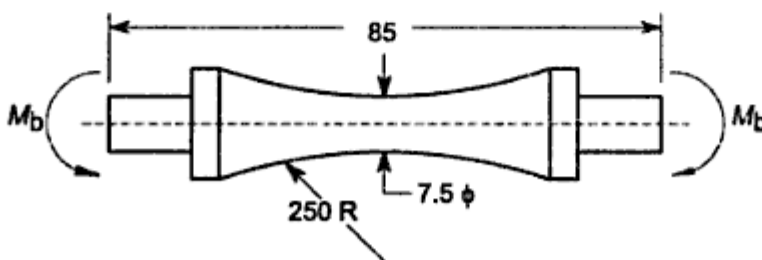

Fig. 2.21 Specimen in Rotating Beam Fatigue Test

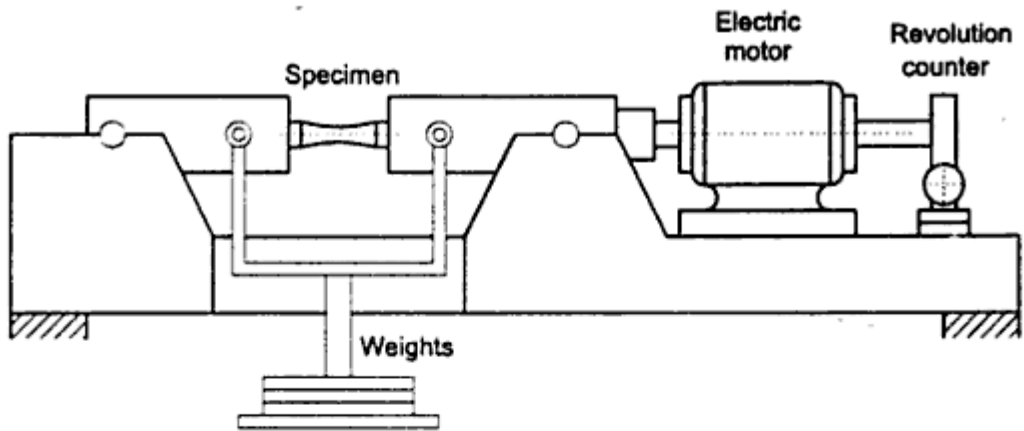

Fig. 2.23 Schematic Diagram of R.R. Moore Rotating Beam Fatigue Machine

For ferrous materials like steels, the  $S-N$  curve becomes asymptotic at  $10^6$  cycles, which indicates the stress amplitude corresponding to infinite number of stress cycles. The magnitude of this stress amplitude at  $10^6$  cycles represents the endurance limit of the material. The  $S-N$  curve shown in Fig. 2.24 is valid only for ferrous metals. For non-ferrous metals like aluminium alloys, the  $S-N$  curve slopes gradually even after  $10^6$  cycles. These materials do not exhibit a distinct value of the endurance limit in a true sense. For these materials, endurance limit stress is sometimes expressed as a function of the number of stress cycles.

The endurance limit, in a true sense, is not exactly a property of material like ultimate or yield strengths. It is affected by the size and shape of component, the surface finish, temperature and the notch sensitivity of the material.

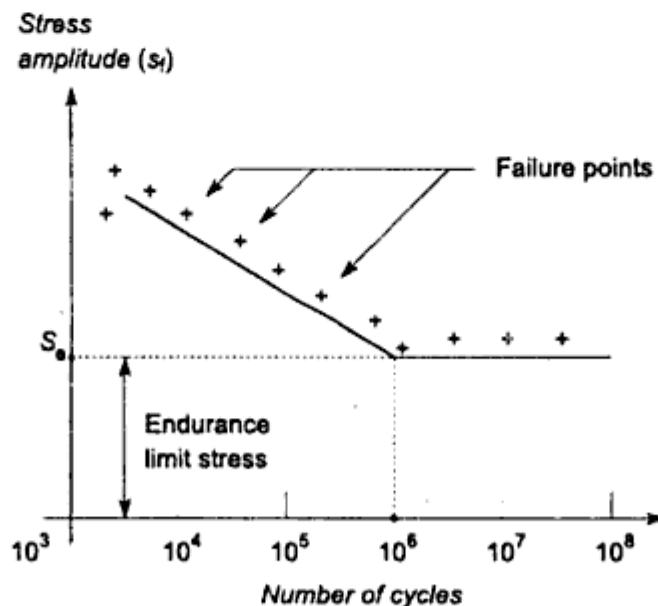

Fig. 2.24 S-N curve for Steels



(iv) *Manufacturing considerations:* In some applications, machinability of material is an important consideration in selection. Sometimes, an expensive material is more economical than a low priced one, which is difficult to machine. Free cutting steels have excellent machinability due to sulphur content, which is important factor in their selection for high strength bolts, axles and shafts. Where the product is of complex shape, castability or ability of molten metal to flow into intricate passages is the criterion of material selection. In fabricated assemblies of plates and rods, weldability becomes the governing factor. The manufacturing processes, such as casting, forging, extrusion, welding and machining govern the selection of material.

Past experience is a good guide for the selection of material, however, designer should not overlook the possibilities of new materials.

## 2.10 CAST IRON

Cast iron is a generic term which refers to a family of materials that differ widely in their mechanical properties. By definition, cast iron is an alloy of iron and carbon, containing more than 2 per cent of carbon. In addition to carbon, cast iron contains other elements like silicon, manganese, sulphur and phosphorus. There is a basic difference between steels and cast iron. Steels usually contain less than 1 per cent carbon while cast iron normally contains 2 to 4 per cent carbon. Typical composition of ordinary cast iron is shown in Table 2.1.

**Table 2.1** Composition of ordinary cast iron

carbon	3.0–4.0%
silicon	1.0–3.0%
manganese	0.5–1.0%
sulphur	up to 0.1%
phosphorus	up to 0.1%
iron	remainder

The mechanical properties of cast iron components are inferior to the parts which are machined from rolled steels. However, even with this drawback, cast iron offers the only choice under certain conditions. From design considerations, cast iron offers the following advantages:

- (i) It is available in large quantities and is produced on a mass scale. The tooling required for the casting process is relatively simple and inexpensive. This reduces the cost of cast iron products.
- (ii) Cast iron components can be given any complex shape without involving costly machining operations.
- (iii) Cast iron has a higher compressive strength. Compared with steel, its compressive strength is three to five times more, which can be used to advantage in certain applications.

- (iv) Cast iron has an excellent ability to damp vibrations, which makes it an ideal choice for machine tool guides and frames.
- (v) Cast iron has more resistance to wear even under the conditions of boundary lubrication.
- (vi) The mechanical properties of cast iron parts do not change between room temperature and 350°C.
- (vii) Cast iron parts have low notch sensitivity.

Cast iron has certain drawbacks too. It has a poor tensile strength compared to steel. Cast iron parts are section-sensitive. Even with the same chemical composition, the tensile strength of cast iron part decreases as the thickness of the section increases. This is due to the low cooling rate of thick sections. For thin sections, the cooling rate is high, resulting in increased hardness and strength. Cast iron does not offer any plastic deformation before failure and exhibit no yield point. The failure of cast iron parts is sudden and total. Cast iron parts are, therefore, not suitable for applications where permanent deformation is preferred over fracture. Cast iron is brittle and has poor impact resistance. The machinability of cast iron parts is poor compared to parts made of steel.

Cast irons are classified on the basis of distribution of carbon content in their microstructure. There are three popular types of cast iron - grey, malleable and ductile. Grey cast iron is formed when the carbon content in the alloy exceeds the amount that can be dissolved. Therefore, some part of carbon precipitates and remains present as 'graphite flakes' distributed in a matrix of ferrite or pearlite or their combination. When a component of grey cast iron is broken, the fractured surface has grey appearance due to graphite flakes. Grey cast iron is specified by symbol FG followed by the tensile strength in  $\text{N/mm}^2$  for a 30 mm section. For example FG200, in general, means a grey cast iron with ultimate tensile strength of  $200 \text{ N/mm}^2$ . Grey cast iron is used for automotive components such as cylinder block, brake drum, clutch plates, cylinder and cylinder head, gears and housing of gear box, flywheel and machine frame, bed and guide.

White cast iron is formed when most of the carbon content in the alloy forms iron carbide and there are no graphite flakes. Malleable cast iron is first cast as white cast iron and then converted into malleable cast iron by heat treatment. In malleable cast iron, the carbon is present in the form of irregularly shaped nodules of graphite called 'temper' carbon. There are three basic types of malleable cast iron - *blackheart*, *pearlitic* and *whiteheart*, which are designated by symbols BM, PM and WM respectively and followed by minimum tensile strength in  $\text{N/mm}^2$ . For example,

- (i) BM350 is blackheart malleable cast iron with minimum tensile strength of  $350 \text{ N/mm}^2$ ,
- (ii) PM600 is pearlitic malleable cast iron with minimum tensile strength of  $600 \text{ N/mm}^2$  and
- (iii) WM400 is whiteheart malleable cast iron with minimum tensile strength of  $400 \text{ N/mm}^2$ .

*Blackheart malleable cast iron* has excellent castability and machinability. It is used for brake shoe, pedal, lever, wheel hub, axle housing and door hinges. *Whiteheart malleable cast iron* is particularly suitable for manufacture of thin castings which require ductility. It is used for pipe fittings, switchgear equipment, fittings for bicycle and motorcycle frames. *Pearlitic malleable iron castings* can be selectively hardened by heat treatment. It is used for general engineering components with specified dimensional tolerances.

*Ductile cast iron* is also called nodular cast iron or spheroidal graphite cast iron. In ductile cast iron, carbon is present in the form of spherical nodules called 'spherulites' or 'globules' in a relatively ductile matrix. When a component of ductile cast iron is broken, the fractured surface has bright steely appearance. Ductile cast iron is designated by symbol SG (spheroidal graphite) followed by minimum tensile strength in  $\text{N/mm}^2$  and minimum elongation in per cent. For example, SG 800/2 is spheroidal graphite cast iron with minimum tensile strength of  $800 \text{ N/mm}^2$  and minimum elongation of 2 per cent. Ductile cast iron is used for crankshaft, heavy duty gears and automobile door hinges. Ductile cast iron combines the processing advantages of grey cast iron with the engineering advantages of steel. Spheroidal graphite cast iron is dimensionally stable at high temperatures and therefore, used for furnace doors, furnace components and steam plants. Because of excellent corrosion resistance, it is used for pipelines in chemical and petroleum industries.

Mechanical properties of grey<sup>9</sup>, malleable<sup>10</sup> and ductile<sup>11</sup> cast iron are given in Table 2.2.

## 2.11 DESIGN CONSIDERATIONS OF CASTINGS

Poor shaping of a cast-iron component can adversely affect its strength more than the composition of the material. Before designing castings, the designer should consult the foundryman and the pattern-maker, whose cooperation is essential for a successful design. The general principles for the design of casting<sup>12</sup> are as follows:

- (i) **Always keep the stressed areas of the part in compression.** Cast iron has more compressive strength than its tensile strength. The balanced sections with equal areas in tension and compression are not suitable for cast iron components. The castings should be placed in such a way that they are subjected to compressive rather than tensile stresses as illustrated in Fig. 2.25. When tensile stresses are unavoidable, a clamping device

9. I.S. 210-1993, *Grey iron castings, specification*.

10. I.S. 14329-1995, *Malleable iron castings, specification*.

11. I.S. 1865-1991, *Iron castings with spheroidal or nodular graphite, specification*.

12. John B Caine, 'Five ways to improve grey iron-castings', *Machine Design*, vol. 36, no. 25, October 22, 1964.

Table 2.2 Mechanical properties of cast iron

<i>Grade</i>	<i>Tensile strength (Min.) (N/mm<sup>2</sup>)</i>	<i>Elongation (Min.) (%)</i>	<i>Hardness (HB)</i>
<b>(A) Grey cast iron</b>			
FG 150	150	—	130-180
FG 200	200	—	160-220
FG 220	220	—	180-220
FG 260	260	—	180-230
FG 300	300	—	180-230
FG 350	350	—	207-241
FG 400	400	—	207-270
<b>(B) Whiteheart Malleable cast iron</b>			
WM 400	400	5	220 (Max.)
WM 350	350	3	230 (Max.)
<b>(C) Blackheart Malleable cast iron</b>			
BM 350	350	10	150 (Max.)
BM 320	320	12	150 (Max.)
BM 300	300	6	150 (Max.)
<b>(D) Pearlitic Malleable cast iron</b>			
PM 700	700	2	240-290
PM 600	600	3	200-250
PM 550	550	4	180-230
PM 500	500	5	160-200
PM 450	450	6	150-200
<b>(E) Spheroidal Graphite cast iron</b>			
SG 900/2	900	2	280-360
SG 800/2	800	2	245-335
SG 700/2	700	2	225-305
SG 600/3	600	3	190-270
SG 500/7	500	7	160-240
SG 450/10	450	10	160-210
SG 400/15	400	15	130-180
SG 350/22	350	22	150 (Max.)

such as a tie rod or a bearing cap as illustrated in Fig. 2.26 should be considered. The clamping device relieves the cast-iron components from tensile stresses.

- (ii) **Round all external corners.** It has two advantages—it increases the endurance limit of the component and reduces the formation of brittle chilled edges. When the metal in the corner cools faster than the metal adjacent to the corner, brittle chilled edges are formed due to iron carbide. Appropriate fillet radius, as illustrated in Fig. 2.27 reduces the stress concentration. The values of the corner radii for different section thicknesses are as follows :

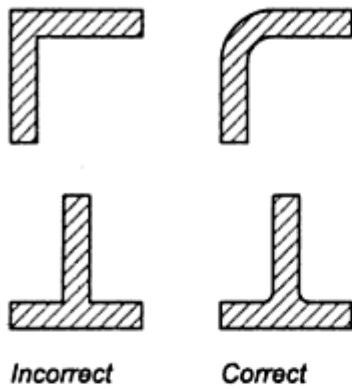

Fig. 2.27 Provision of Fillet Radius



Fig. 2.29

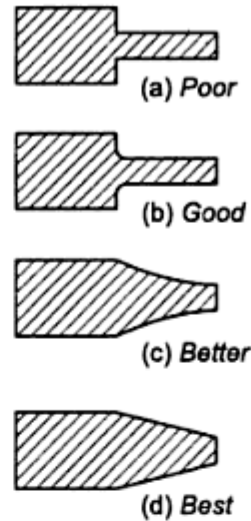

Fig. 2.28 Change in Section-thickness

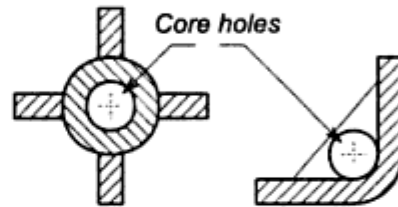

Fig. 2.30 Cored Holes

(v) **Avoid very thin sections.** In general, if the thickness of a cast iron component is calculated from strength considerations, it is often too small. In such cases, the thickness should be increased to certain practical proportions. The minimum section thickness depends upon the process of casting, such as sand casting, permanent mould casting or die casting. The minimum thickness for grey cast iron component is about 7 mm for parts up to 500 mm long, which gradually increases to 20 mm for large and heavy castings.

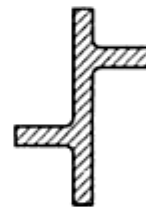

Fig. 2.31 Staggered Ribs

(vi) **Shot blast the parts wherever possible.** The shot blasting process improves the endurance limit of the component, particularly in case of thin sections.

Some ways to improve the strength of castings are illustrated in Figs 2.32 to 2.35. In Fig. 2.32 the inserted stud will not restore the strength of the original thickness. The wall adjacent to the drilled hole should have a thickness equivalent to the thickness of the main body. Figure 2.33 shows cored holes in webs or ribs. Oval-shaped holes are preferred with larger dimensions along the direction of

- (i) Tensile strength,
- (ii) Carbon content, and
- (iii) Composition of alloying elements.

Steels which are standardised on the basis of their tensile strength without detailed chemical composition, are specified by two ways - symbol Fe followed by the minimum tensile strength in  $\text{N/mm}^2$  or symbol FeE followed by the yield stress in  $\text{N/mm}^2$ . For example, Fe 360 indicates a steel with a minimum tensile strength of  $360 \text{ N/mm}^2$ . Similarly FeE 250 indicates a steel with minimum yield stress of  $250 \text{ N/mm}^2$ .

The designation of plain carbon steel consists of the following three quantities:

- (i) A figure indicating 100 times the average percentage of carbon,
- (ii) A letter C, and
- (iii) A figure indicating 10 times the average percentage of manganese.

As an example, 55C4 indicates a plain carbon steel with 0.55% carbon and 0.4% manganese. A steel with 0.35–0.45% carbon and 0.7–0.9% manganese is designated as 40C8.

The designation of unalloyed free cutting steels consists of following quantities:

- (i) A figure indicating 100 times the average percentage of carbon,
- (ii) A letter C,
- (iii) A figure indicating 10 times the average percentage of manganese,
- (iv) A symbol 'S', 'Se', 'Te' or 'Pb' depending upon the element present which makes the steel free cutting, and
- (v) A figure indicating 100 times the average percentage of the above element that makes the steel free cutting.

As an example, 25C12S14 indicates a free cutting steel with 0.25% carbon, 1.2% manganese and 0.14% sulphur. Similarly, a free cutting steel with average 0.20% carbon, 1.2% manganese and 0.15% lead is designated as 20C12Pb15.

The term 'alloy' steel is used for low and medium alloy steels containing total alloying elements not exceeding 10 per cent. The designation of alloy steels consists of following quantities :

- (i) A figure indicating 100 times the average percentage of carbon, and
- (ii) Chemical symbols for alloying elements each followed by the figure for its average percentage content multiplied by a factor. The multiplying factor depends upon the alloying element. The values of this factor are given in Table 2.3.

**Table 2.3** Multiplying factors for alloying elements in steel

<i>Elements</i>	<i>Multiplying factor</i>
Cr, Co, Ni, Mn, Si and W	4
Al, Be, V, Pb, Cu, Nb, Ti, Ta, Zr and Mo	10
P, S, N	100

In alloy steels, symbol 'Mn' for manganese is included only if the content of manganese is equal to or greater than 1 per cent. The chemical symbols and their figures are arranged in descending order of their percentage content.

As an example, 25Cr4Mo2 is an alloy steel having average 0.25% carbon, 1% chromium and 0.2% molybdenum. Similarly, 40Ni8Cr8V2 is an alloy steel containing average 0.4% carbon, 2% nickel, 2% chromium and 0.2% vanadium. Consider an alloy steel with the following composition.

carbon	0.12 to 0.18%
silicon	0.15 to 0.35%
manganese	0.40 to 0.60%
chromium	0.50 to 0.80%

The average percentage of carbon is 0.15%, which is denoted by the number  $(0.15 \times 100)$  or 15. Percentage content of silicon and manganese is negligible and they are deleted from the designation. The significant element is chromium and its average percentage is 0.65. The multiplying factor for chromium is 4 and  $(0.65 \times 4)$  is 2.6, which is rounded to 3. Therefore, the complete designation of steel is 15Cr3. As a second example, consider a steel with the following chemical composition.

carbon	0.12–0.20%
silicon	0.15–0.35%
manganese	0.60–1.00%
nickel	0.60–1.00%
chromium	0.40–0.80%

The average percentage of carbon is 0.16% and multiplying this value by 100, the first figure in designation of steel is 16. The average percentage of silicon and manganese is very small and the symbols Si and Mn are deleted. Average percentages of nickel and chromium are 0.8 and 0.6 respectively and the multiplying factor for both elements is 4. Therefore,

$$\begin{aligned} \text{nickel} & : 0.8 \times 4 = 3.2 \text{ rounded to 3 or Ni3} \\ \text{chromium} & : 0.6 \times 4 = 2.4 \text{ rounded to 2 or Cr2.} \end{aligned}$$

The complete designation of steel is 16Ni3Cr2.

The term 'high alloy steels' is used for alloy steels containing more than 10 per cent of alloying elements. The designation of high alloy steels consists of following quantities:

- (i) A letter 'X',
- (ii) A figure indicating 100 times the average percentage of carbon,
- (iii) Chemical symbol for alloying elements each followed by the figure for its average percentage content rounded off to nearest integer, and
- (iv) Chemical symbol to indicate specially added element to attain desired properties, if any.

As an example X15Cr25Ni12 is high alloy steel with 0.15% carbon, 25% chromium and 12% nickel. As a second example, consider a steel with the following chemical composition.

carbon	0.15 to 0.25%
silicon	0.10 to 0.50%
manganese	0.30 to 0.50%
nickel	1.5 to 2.5%
chromium	16 to 20%

The average content of carbon is 0.20% which is denoted by a number ( $0.20 \times 100$ ) or 20. The major alloying elements are chromium (average 18%) and nickel (average 2%). Hence, the designation of steel is X20Cr18Ni2.

### 2.13 PLAIN CARBON STEELS

Depending upon the percentage of carbon, plain carbon steels are classified into three groups—*low carbon*, *medium carbon* and *high carbon steels*. *Low carbon steel* has less than 0.3% carbon content. It is popularly called mild steel. It is not possible to harden mild steel by heat treatment. *Medium carbon steel* has carbon content in the range of 0.3% to 0.7%. They are popularly known as machinery steels. Medium carbon steels are easily hardened by heat treatment. High carbon steel contains carbon in the range of 0.7% to 1.4%. They are called hard steels or tool steels. Plain carbon steels are available in the form of bars, tubes, plates, sheets and wires. Some of the important applications of these steels are shown in Table 2.4.

**Table 2.4** Important application of plain carbon steels

7C4	:	components made by severe drawing operations such as automobile bodies and hoods.
10C4	:	case hardened components such as cam and cam shaft, worm, gudgeon pin, chain wheel and spindle.
30C8	:	cold formed and case hardened parts such as socket, tie rod, yoke, lever and rocker arm.
40C8	:	transmission shaft, crank shaft, spindle, connecting rod, stud and bolt.
45C8	:	transmission shaft, machine tool spindle, bolt and gear of large dimensions.
50C4	:	transmission shaft, worm, gear and cylinder.
55C8	:	components with moderate wear resistance such as gear, cam, sprocket, cylinder and key.
60C4	:	machine tool spindle, hardened bolt and pinion.
65C6	:	flat and coil springs.

The mechanical properties of plain carbon steel<sup>15</sup> are given in Table 2.5.



**Table 2.5** Mechanical properties of plain carbon steels

<i>Grade</i>	<i>Tensile strength</i> ( <i>Min.</i> ) ( <i>N/mm<sup>2</sup></i> )	<i>Yield strength</i> ( <i>Min.</i> ) ( <i>N/mm<sup>2</sup></i> )	<i>Hardness</i> ( <i>HB</i> )
7C4	320	—	—
10C4	340	—	—
30C8	500	400	179
40C8	580	380	217
45C8	630	380	229
50C4	660	460	241
55C8	720	460	265
60C4	750	—	255
65C6	750	—	255

## 2.14 FREE CUTTING STEELS

Steels of this group include carbon steels and carbon-manganese steels with a small percentage of sulphur. Due to addition of sulphur, the machinability of these steels is improved. Machinability can be defined as the ease with which a component can be machined. It involves three factors - the ease of chip formation, the ability to achieve a good surface finish and achievement of an economical tool life. Machinability is important consideration for parts made by automatic machine tools. Typical applications of free cutting steels are studs, bolts and nuts. Mechanical properties of free cutting steels<sup>16</sup> are given in Table 2.6.

**Table 2.6** Mechanical properties of free-cutting steels (cold drawn bars) (20-40 mm diameter)

<i>Grade</i>	<i>Tensile strength</i> ( <i>Min.</i> ) ( <i>N/mm<sup>2</sup></i> )	<i>Elongation</i> ( <i>Min.</i> ) (%)
10C8S10	460	10
14C14S14	520	11
25C12S14	560	10
40C10S18	600	10
40C15S12	640	8

## 2.15 ALLOY STEELS

An alloy steel is defined as a carbon steel to which one or more alloying elements are added to obtain certain beneficial effects. The commonly added elements include silicon, manganese, nickel, chromium, molybdenum and tungsten. The

- I.S. 1570 (Part 2/Sec1), 1979: *Schedules for wrought steels-carbon steels (unalloyed steels)*.
- I.S. 1570 (Part 3), 1979: *Schedules for wrought steel-carbon and carbon manganese free-cutting steels*.

They retain strength and hardness at elevated temperatures. Chromium steels containing more than 4 per cent chromium have excellent corrosion resistance.

- (v) **Molybdenum:** Molybdenum increases hardness and wear resistance. It resists softening of steel during tempering and heating.
- (vi) **Tungsten:** Tungsten and molybdenum have similar effects. It is an expensive alloying element and about 2 to 3 per cent tungsten is required to replace 1 per cent of molybdenum. It is an important alloying element in tool steels.

Some of the important applications of alloy steels are as shown in Table 2.7.

**Table 2.7** Important applications of alloy steels

55Si7	: leaf and coil springs of vehicles.
37C15	: axles, shafts and crankshafts.
35Mn6Mo3	: bolts, studs, axles, levers and general engineering components.
16Mn5Cr4	: gears and shafts.
40Cr4	: gears, axles and steering arms.
50Cr4	: coil, laminated and volute springs.
40Cr4Mo2	: shafts, axles, high tensile bolts, studs and popeller shafts.
40Cr13Mo10V2	: components subjected to high tensile stresses.
40Ni14	: severely stressed screws, nuts and bolts.
16Ni3Cr2	: gears, transmission components, cams and camshafts.
30Ni16Cr5	: heavy duty gears.
35Ni5Cr2	: gear shafts, crankshafts, chain parts, cam shafts and planetary gears.
40Ni6Cr4Mo2	: general machine parts, nuts and bolts, gears, axles, shafts and connecting rods.
40Ni10Cr3Mo6	: high strength machine components, bolts and studs, axles and shafts, gears and crankshafts.

Mechanical properties of alloy steels<sup>17</sup> are given in Table 2.8.

## 2.16 OVERSEAS STANDARDS

Cast iron and steel are the essential ingredients in any product. A large variety of steel and cast iron is developed for a number of applications. In our country, collaborations with foreign industries have resulted in use of different overseas standards and designations. Some important designations for ferrous materials are as follows:<sup>18, 19, 20, 21</sup>

17. I.S. 1570 (Part 4), 1988: *Schedules for wrought steels-Alloy steels with specified chemical composition and mechanical properties.*
18. SAE J402: 1984, *SAE Numbering system for wrought or rolled steel* (SAE standard).
19. *SAE Handbook*, Vol.1, *Materials*, Society of Automotive Engineers Inc., 1987.
20. *Metals Handbook*, Vol.1, *Properties and selection: Iron, steels and high performance alloys*, American Society of Metals Inc., 1990.
21. Bagchi SN and Kuldip Prakash, 'Industrial steel reference book', Wiley Eastern Ltd., New Delhi, 1986.

**Table 2.9** Basic numbering system of SAE and AISI steels

<i>Material</i>	<i>SAE or AISI Number</i>
Carbon steels	1xxx
Plain carbon	10xx
Free-cutting, screw stock	11xx
Chromium steels	5xxx
Low chromium	51xx
Medium chromium	52xxx
Corrosion and heat resisting	51xxx
Chromium-nickel-molybdenum steels	86xx
Chromium-nickel-molybdenum steels	87xx
Chromium-vanadium steels	6xxx
1.00% Cr	61xx
Manganese steels	13xx
Molybdenum steels	4xxx
carbon-molybdenum	40xx
chromium-molybdenum	41xx
chromium-nickel-molybdenum	43xx
nickel-molybdenum; 1.75% Ni	46xx
nickel-molybdenum; 3.50% Ni	48xx
Nickel-chromium steels	3xxx
1.25% Ni, 0.60% Cr	31xx
1.75% Ni, 1.00% Cr	32xx
3.50% Ni, 1.50% Cr	33xx
Silicon-manganese steels	9xxx
2.00% Si	92xx
Nickel steels	2xxx
3.5% Ni	23xx
5.0% Ni	25xx

- (i) The American Society for Testing Materials (A.S.T.M.) has classified grey cast iron by means of a number. This class number gives minimum tensile strength in kpsi. For example, ASTM Class No.20 has minimum ultimate tensile strength of 20 000 psi. Similarly, a cast iron with minimum ultimate tensile strength of 50 000 psi is designated as ASTM Class No.50. Commonly used ASTM classes of cast iron are 20, 25, 30, 35, 40, 50 and 60.
- (ii) In Germany, Deutches Institut Fuer Normung (D.I.N.) has specified grey cast iron by minimum ultimate tensile strength in  $\text{kgf/mm}^2$ . For example, GG-12 indicates grey cast iron with minimum ultimate tensile strength of  $12 \text{ kgf/mm}^2$ . Similarly, grey cast iron with minimum ultimate tensile strength of  $26 \text{ kgf/mm}^2$  is designated as GG-26. The common varieties of grey cast iron are GG-12, GG-14, GG-18, GG-22, GG-26 and GG-30.
- (iii) A numbering system for carbon and alloy steels is prescribed by Society of Automotive Engineers (S.A.E.) of USA and American Iron and Steel Institute (A.I.S.I.). It is based on chemical composition of the steel. The number is composed of four or five digits. The first two digits indicate the

type or alloy classification. The last two or three digits give the carbon content. Since carbon is the most important element in steel affecting the strength and hardness, it is given proper weightage in this numbering system. The basic numbers for various types of steel are given in Table 2.9. For example, plain carbon steel has 1 and 0 as its first two digits. Thus, a steel designated as 1045 indicates plain carbon steel with 0.45% carbon. Similarly, a nickel-chromium steel with 1.25% Ni, 0.60% Cr and 0.40% carbon is specified as SAE 3140.

The AISI number for steel is same as SAE number. In addition, there is a capital letter *A, B, C, D* or *E* that is prefixed to the number. These capital letters indicate the manufacturing process of steel. The meaning of these letters is as follows,

- A* – Basic open-hearth alloy steel
- B* – Acid Bessemer carbon steel
- C* – Basic open-hearth carbon steel
- D* – Acid open-hearth carbon steel
- E* – Electric furnace alloy steel

British system designates steel in a series of numbers known as 'En' series. The En number of a steel has no correlation either with the chemical composition such as carbon content and types of alloying element or mechanical properties such as ultimate tensile strength. For example, the number 3 in En3 steel has no relationship with carbon content, alloying element or strength of steel. Table 2.10 shows the overseas equivalent designations of some popular varieties of steel.

## 2.17 HEAT TREATMENT OF STEELS

The heat treatment process consists of controlled heating and cooling of components made of either plain carbon steel or alloy steel, for the purpose of changing their structure in order to obtain certain desirable properties like hardness, strength or ductility. The major heat treatment processes are as follows:

- (i) **Annealing** consists of heating the component to a temperature slightly above the critical temperature, followed by slow cooling. It reduces hardness and increases ductility.
- (ii) **Normalising** is similar to annealing, except that the component is slowly cooled in air. It is used to remove the effects of the previous heat treatment processes.
- (iii) **Quenching** consists of heating the component to the critical temperature and cooling it rapidly in water or air. It increases hardness and wear resistance. However, during the process, the component becomes brittle and ductility is reduced.
- (iv) **Tempering** consists of reheating the quenched component to a temperature below the transformation range, followed by cooling at a desired rate. It restores the ductility and reduces the brittleness due to quenching.

The recommended hardening and tempering treatments and temperature ranges can be obtained from the standards. The selection of a proper heat treatment

Table 2.10 Overseas equivalent designations of steel

<i>B.I.S. designation</i>	<i>En Number</i>	<i>S.A.E.</i>	<i>A.I.S.I.</i>	<i>D.I.N.</i>
<b>Plain carbon steels :</b>				
7C4	2A	1010	C 1010	17210
10C4	32A	1012	C 1012	17155
30C8	5	1030	C 1030	—
45C8	43B	1045	C 1045	17200
50C4	43A	1049, 1050	C 1049, C 1050	—
55C8	43J, 9K	1055	C 1055	—
60C4	43D	1060	C 1060	17200
65C6	42B	1064	C 1064	17222
<b>Free cutting steels :</b>				
10C8S10	—	1109	C 1109	—
14C14S14	7A, 202	1117, 1118	C 1117, C 1118	—
25C12S14	7	1126	C 1126	—
40C10S18	8M	1140	C 1140	—
40C15S12	15AM	1137	C 1137	—
<b>Alloy steels :</b>				
40Cr4	18	5135	5135	—
40Ni14	22	2340	2340	—
35Ni5Cr2	111	3140	3140	1662
30Ni16Cr5	30A	—	—	—
40Ni6Cr4Mo2	110	4340	4340	17200
27C15	14B	1036	C 1036	17200
37C15	15, 15A	1041, 1036	C 1041, C 1036	17200
50Cr4V2	47	6150	6150	17221

process depends upon the desirable properties of the component required in the particular application.

## 2.18 CASE HARDENING OF STEELS

In a number of situations, the stress distribution across the cross-section of a component is not uniform. In some cases, the surface is heavily stressed, while the stresses in the core are of comparatively small magnitude. The examples of this type of stress distribution are gears, cams and rolling contact bearings. The surface failure of these components can be avoided by case-hardening. Case-hardening can be achieved by the following two ways :

- (i) By altering the structure at the surface by local hardening, e.g. flame or induction hardening.
- (ii) By altering the structure as well as the composition at the surface, e.g. case carburising, nitriding, cyaniding and carbo-nitriding.

**Flame-hardening** consists of heating the surface above the transformation range by means of a flame, followed by quenching. The distortion of the

component is low because the bulk of the work piece is not heated. Flame-hardening can be done in stages, such as hardening of tooth by tooth of a gear blank. The minimum case depth obtained by this process is 1 mm, although case depths up to 6 mm are quite common. Flame-hardening is recommended under the following situations:

- (i) Where the component is large,
- (ii) Where a small area of work piece is to be hardened, and
- (iii) Where dimensional accuracy is desirable.

Carbon steels containing more than 0.4% carbon are generally employed for flame-hardening.

The **induction-hardening** process consists of heating the surface by induction in the field of an alternating current. The amount of heat generated depends upon the resistivity of the material. Induction-hardening produces case depths as small as 0.1 mm. There is not much difference between flame and induction-hardening, except for the mode of heating and minimum case depth.

**Case-carburising** consists of introducing carbon at the surface layer. Such a component has a high-carbon surface layer and low-carbon core with a gradual transformation from one zone to the other. Different methods are used to introduce carbon, but all involve heating from 880 to 980°C. The carburising medium can be solid, liquid or gas. Case-carburising is recommended for case depths up to 2 mm.

**Carbo-nitriding** consists of introducing carbon and nitrogen simultaneously at the surface layer. The component is heated from 650 to 920°C in the atmosphere of unhydrous ammonia and then quenched in a suitable medium. Nitrogen is concentrated at the surface and backed up by a carburised case. Medium carbon steels are carbo-nitrided with case depths up to 0.6 mm. The process gives a higher wear resistance compared to the case-carburising process. Cyaniding is similar to carbo-nitriding except that the medium is liquid.

**Nitriding** consists of exposing the component to the action of nascent nitrogen in a gaseous or liquid medium from 490 to 590°C. This process does not involve any subsequent quenching. The gaseous medium consists of dry ammonia and the liquid medium of cyanides and cyanates. The nitrided case consists of two zones—a brittle white zone next to surface, consisting of nitrides, followed by a tougher diffusion zone, where nitrides are precipitated in the matrix. Case depths up to 0.1 mm are obtained by this process. Nitrided components are used for applications requiring high resistance to abrasion, fatigue properties and freedom from distortion. The disadvantages of this process are as follows:

- (i) The components cannot be used for concentrated loads and shocks,
- (ii) The case depth is limited to 0.5 mm, and
- (iii) Considerable time is required for the process due to long cycle time.

The applications of the nitrided component are indexing worm, high-speed spindle and crank shaft.

## 2.20 ALUMINIUM ALLOYS

Aluminium alloys are recent in origin compared with copper or steel, however, due to a unique combination of certain mechanical properties, they have become the most widely used nonferrous material. Aluminium alloys offer following design advantages :

- (i) *Low specific gravity:* The relative density of aluminium alloys is 2.7 compared with 7.9 of steels, i.e. roughly one third of steel. This results in light weight construction and reduces inertia forces in applications like connecting rod and piston, which are subjected to reciprocating motion.
- (ii) *Corrosion resistance:* Aluminium has high affinity for oxygen and it might be expected that aluminium components will oxidise or rust very easily, however, in practice it has an excellent resistance to corrosion. This is due to the thin but very dense film of oxide (alumina skin) which forms on the surface of metal and protects it from further atmospheric attack. It is due to alumina skin, that there is comparatively dull appearance on the surface of polished aluminium component.

**Table 2.11** Mechanical properties of carbon steel castings

<i>Grade</i>	<i>Yield stress</i> (Min.) (N/mm <sup>2</sup> )	<i>Tensile strength</i> (Min.) (N/mm <sup>2</sup> )	<i>Elongation</i> (Min.) (%)
200-400	200	400	25
230-450	230	450	22
280-520	280	520	18
340-570	340	570	15

**Table 2.12** Mechanical properties of high tensile steel castings.

<i>Grade</i>	<i>Tensile strength</i> (Min.) (N/mm <sup>2</sup> )	<i>Yield stress</i> <sup>1</sup> (Min.) (N/mm <sup>2</sup> )	<i>Elongation</i> (Min.) (%)	<i>Hardness</i> (HB)
CS 640	640	390	15	190
CS 700	700	580	14	207
CS 840	840	700	12	248
CS 1030	1030	850	8	305
CS 1230	1230	1000	5	355

*Note 1:* Yield stress is 0.5 per cent proof stress.

- (iii) *Ease of fabrication:* Aluminium alloys have a face centered cubic crystal structure with many slip planes. This makes the material ductile and easily shaped. They can be cast, rolled, forged or extruded. Aluminium alloys can be formed, hot or cold, with considerable ease. They can be machined easily if suitable practice and proper tools are used. They can be joined by fusion welding, resistance welding, soldering and brazing. Due to their

Some of the important applications of cast aluminium alloy are as shown Table 2.14.

**Table 2.14** Applications of cast aluminium alloys

Alloy 4450	:	engine cylinder block, castings for valve body and large fan blade.
Alloy 4600	:	intricate and thin walled castings, motor housing, water cooled manifold and pump casing.
Alloy 2280	:	connecting rod and flywheel housing.
Alloy 2285	:	piston and cylinder head.
(Y-alloy)		
Alloy 2250	:	castings for hydraulic equipment.
Alloy 4652	:	piston for internal combustion engine.

The alloy 4600 is used for pressure die casting parts. It has excellent fluidity which facilitates the production of complex castings of large surface area and thin walls. The mechanical properties of aluminium alloy castings are given in Table 2.15.

**Table 2.15** Mechanical properties of cast aluminium alloys

Alloy	Condition	Tensile Strength (Min.) (N/mm <sup>2</sup> )		Elongation (Min.) (%)	
		Sand-cast	Chill-cast	Sand-cast	Chill-cast
4450	M	135	160	2	3
	T5	160	190	1	2
	T7	160	225	2.5	5
	T6	225	275	—	2
4600	M	165	190	5	7
2280	T4	215	265	7	13
	T6	275	310	4	9
2285	T6	215	280	—	—
2550	M	—	170	—	—
4652	T5	—	210	—	—
	T6	140	200	—	—
	T7	—	280	—	—

(M = as cast; T5 = precipitation treated; T4 = solution treated; T7 = solution treated and stabilised; T6 = solution and precipitation treated)

The important applications of wrought aluminium alloys are as shown in Table 2.16.

**Table 2.16** Applications of wrought-aluminium alloys

Alloy 24345	:	heavy duty forgings and structures.
Alloy 24534	:	stressed components of aircraft.
Alloy 54300	:	welded structures and tanks.
Alloy 64430	:	roof trusses and deep-drawn containers.
Alloy 74530	:	welded pressure vessels.



The mechanical properties of wrought aluminium alloys are given in Table 2.17.

**Table 2.17** Mechanical properties of wrought aluminium and aluminium alloys

Alloy	Condition	Diameter (mm)		0.2 per cent proof stress (N/mm <sup>2</sup> )		Tensile strength (N/mm <sup>2</sup> )		Elongation (Min) (%)
		over	upto	Min.	Max.	Min.	Max.	
24345	M	—	—	90	—	150	—	12
		—	—	—	175	—	240	12
	W	—	10	225	—	375	—	10
		10	75	235	—	385	—	10
		75	150	235	—	385	—	8
		150	200	225	—	375	—	8
		—	10	375	—	430	—	6
	WP	10	25	400	—	460	—	6
		25	75	420	—	480	—	6
		75	150	405	—	460	—	6
150		200	380	—	430	—	6	
24534	M	—	—	90	—	150	—	12
		—	—	—	175	—	240	12
	W	—	10	220	—	—	375	10
		10	75	235	—	385	—	10
		75	150	235	—	385	—	8
150	200	225	—	375	—	8		
54300	M	—	150	130	—	265	—	11
	O	—	150	125	—	—	350	13
64430	M	—	—	80	—	110	—	12
		—	—	—	—	—	150	16
	W	—	150	120	—	185	—	14
		150	200	100	—	170	—	12
		—	5	225	—	295	—	7
	WP	5	75	270	—	310	—	7
75		150	270	—	295	—	7	
74530	W <sup>1</sup>	150	200	240	—	280	—	6
		—	6	220	—	255	—	9
		6	75	230	—	275	—	9
	WP	75	150	220	—	265	—	9
		—	6	245	—	285	—	7
		6	75	260	—	310	—	7
		75	150	245	—	290	—	7

Note: 1 Naturally aged for 30 days

(M = as manufactured; O = annealed, W = solution treated and naturally aged, WP = solution and precipitation treated)

## 2.21 COPPER ALLOYS

Copper possesses excellent thermal and electrical conductivity. It can be easily cast, machined and brazed. It has good corrosion resistance. However, even with

these advantages, pure copper is not used in any structural application due to its poor strength. The tensile strength of copper is about  $220 \text{ N/mm}^2$ . Pure copper is mainly used for electrical and thermal applications. For structural applications, copper alloys are used instead of pure copper. Some of the popular copper alloys are brass, bronze, gun metal and monel metal. Their properties and applications are briefly discussed in this article.

- (i) **Brass:** The most commonly used copper alloy is brass. It is an alloy of copper and zinc. Sometimes, it may contain small amounts of tin, lead, aluminium and manganese. Brass has following advantages:
- The strength of brass is higher than that of copper,
  - Brass is cheaper than copper,
  - Brass has excellent corrosion resistance,
  - Brass has better machinability, and
  - Brass has good thermal conductivity.

The strength and ductility of brass depend upon the zinc content. As the amount of zinc increases, the strength of brass increases and ductility decreases. Best combination of strength and ductility is obtained when the amount of zinc is 30 per cent. Brass can be used either in rolled condition or as cast. Some of the commonly used brasses are yellow brass, naval brass, cartridge brass and muntz metal. Typical applications of brasses in the field of mechanical engineering are tubes for condenser and heat exchanger, automotive radiator cores, rivets, valve stems and bellow springs.

- (ii) **Bronze:** Bronze is an alloy of copper and elements other than zinc. In some cases, bronze may contain small amount of zinc. There are three important varieties of bronze—*aluminium bronze*, *phosphor bronze* and *tin bronze*. *Aluminium bronze* contains 5 to 10 per cent aluminium. It has excellent corrosion resistance, high strength and toughness, low coefficient of friction and good damping properties. It is used for hydraulic valves, bearings, cams and worm gears. The colour of aluminium bronze is similar to that of 22 carat gold and it is frequently called 'imitation' gold. Aluminium bronze is difficult to cast because at its casting temperature around  $1000^\circ\text{C}$ , aluminium oxidises easily.

*Phosphor bronze* contains about 0.2 per cent phosphorus. The effect of phosphorus is to increase the tensile strength and corrosion resistance and reduce the coefficient of friction. In cast form, phosphor bronze is widely used for worm wheels and bearings and in wrought form it is used for springs, bellows, pumps, valves and chemical equipment. *Tin bronze* contains upto 18 per cent tin and sometimes small amounts of phosphorus, zinc or lead. It has excellent machinability, wear properties and low coefficient of friction. It is used for pump castings, valve fittings and bearings. High prices of both copper and tin, put limitations on the use of tin bronze.

In general, all varieties of bronze have following advantages:

- (a) Excellent corrosion resistance,
- (b) Low coefficient of friction, and
- (c) Higher tensile strength than copper or brass.

The main limitation of bronze is high cost.

- (iii) **Gun metal:** Gun metal is an alloy of copper which contains 10 per cent tin and 2 per cent zinc. Presence of zinc improves fluidity of gunmetal during casting process. Zinc is considerably cheaper than tin. Therefore, the total cost of gunmetal is less than that of bronze. In cast form, gun metal is used for bearings. It has excellent corrosion resistance, high strength and low coefficient of friction.
- (iv) **Monel metal:** Monel metal is a copper-nickel alloy. It contains 65% nickel and 32% copper. It has excellent corrosion resistance to acids, alkalies, brine water, sea water and other chemicals. It is mainly used for handling sulphuric and hydrochloric acids. It is also used for pumps and valves for handling the chemicals in process equipment.

## 2.22 DIE CASTING ALLOYS

The die casting process consists of forcing the molten metal into closed metal die. This process is used for metals with low melting point. The advantages of the die casting process are as follows:

- (i) Small parts can be made economically in large quantities.
- (ii) Surface finish obtained by this method is excellent and requires no further finishing.
- (iii) Very thin section or complex shapes can be obtained easily.

The drawbacks include the cost of dies and restriction on the size of the component, since only small parts can be die cast.

Die casting alloys are made from zinc, aluminium and magnesium. Brass can be die cast with certain difficulties of temperature. Zinc die castings are more popular due to their high strength, long die life and moderate casting temperature. Aluminium and magnesium die castings are light weight but their casting temperature is higher than that of zinc die castings.

## 2.23 CERAMICS

Ceramics can be defined as a compound of metallic and non-metallic elements with predominantly 'ionic' interatomic bonding. The word 'ceramic' is derived from the Greek word 'keramos' which means 'potter's clay'. Traditional ceramics include refractories, glass, abrasives, enamels and insulating materials. However, many substances which are now classed as ceramics in fact contain no clay. Modern ceramics include metal oxides, carbides, borides, nitrides and silicates. Some of their examples are as follows,

- (i) Magnesia ( $MgO$ ).
- (ii) Alumina ( $Al_2O_3$ ).

made of ceramics. They include cylinder liner, piston, valve and engine block. The principal advantages of ceramic engine components over conventional metal parts are as follows:

- (i) Ability to withstand higher operating temperature,
- (ii) Excellent wear and corrosion resistance,
- (iii) Lower frictional loss,
- (iv) Ability to operate without cooling system, and
- (v) Light weight construction with low inertia force.

Research is being conducted on gas turbine engines that employ ceramic rotors, stators, regenerators and combustion housings. Other applications include turbine blades for aircraft engine and surface coatings for the engine parts.

## 2.24 PLASTICS

Plastics are synthetic materials processed by heat and pressure. They are perhaps the most widely used group of polymers. Before understanding the construction of plastics, it is necessary to understand two terms—*monomer* and *polymer*. A *monomer* is a group of atoms that constitutes one unit of polymer chain. When monomers are subjected to heat and pressure, they join together to form a chain called polymer. A *polymer* is a nonmetallic organic compound of high molecular weight consisting of a very long chain of monomers. The process of combining monomers into polymer is called polymerisation. Figure 2.36 shows the construction of typical monomers and their corresponding polymers. In this figure, atoms of carbon, hydrogen and other elements are represented by their chemical symbols and their bonds by radial lines.

When short polymer chain is lengthened by adding more and more monomer units, the material becomes more dense and passes from gaseous state to liquid state, from liquid state to semi-solid state and finally becomes tough solid material. Let us consider the example of addition of  $(CH_2)$  unit to polymer chain as shown in Fig. 2.37.

- (i) Initial composition is  $(CH_4)$  which is methane gas.
- (ii) Addition of one unit of  $(CH_2)$  to methane molecule results in heavier ethane gas with  $(C_2H_6)$  composition.
- (iii) Further addition of  $(CH_2)$  units to ethane chain results in pentane, which is in liquid form with  $(C_5H_{12})$  composition.
- (iv) If the process of adding  $(CH_2)$  units to pentane chain is continued, paraffin wax is obtained. It is in semi-solid stage with  $(C_{18}H_{38})$  composition.
- (v) If the process is further continued, a solid plastic called low-density polyethylene is obtained at approximately  $(C_{100}H_{102})$  composition.
- (vi) In the next stage, high-density polyethylene is obtained. It contains about half-million  $(CH_2)$  units in a single chain. It is a very tough solid plastic.

The linking of monomer units is stopped by adding a terminal link called terminator, which satisfies the bonds at each end of the chain.

toughness and reduces brittleness and stiffness. They include polyvinyl chloride and acetate copolymers. Flame retardant is an additive which increases flammability resistance. Most polymers are flammable in their pure form. Flame retardants interfere with combustion process and prevent burning. Pigment or colourant imparts a specific colour to the plastic material.

Plastics are divided into two basic groups depending on their behaviour at elevated temperature, viz. *thermoplastics* and *thermosetting* plastics. *Thermoplastic* is a polymeric material which softens when heated and hardens upon cooling. *Thermosetting* plastic is a polymeric material which once having cured or hardened by a chemical reaction do not soften or melt upon subsequent heating. In short, thermoplastic

softens with heat while thermosetting plastic does not. Thermoplastic material can be moulded and remoulded repeatedly. This difference in properties of thermoplastic and thermosetting plastic materials is due to molecular structure of their polymer chains. Thermoplastic material has linear polymer chain while thermosetting plastic material consists of cross-linked polymer chain as shown in Fig. 2.38. The difference between two categories of plastic materials is as follows:

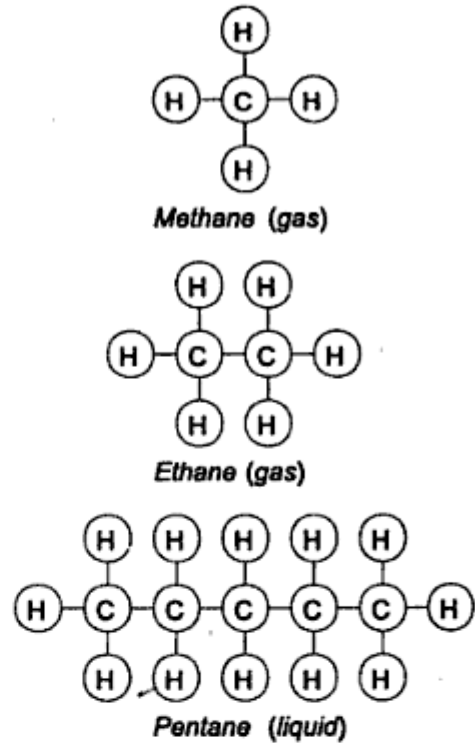

**Fig. 2.37** Monomer Chains

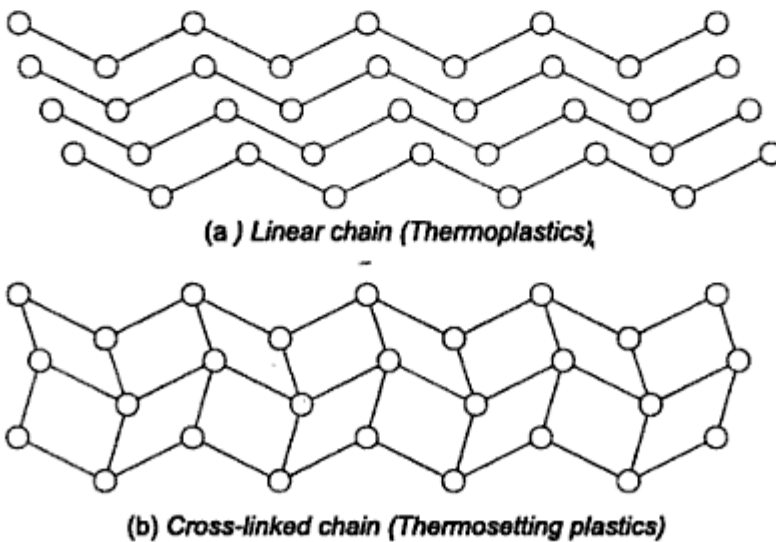

**Fig. 2.38** Linear and Cross-linked Polymer Chains

- (i) Thermoplastic material has linear polymer chain. Thermosetting plastic material has cross-linked polymer chain.
- (ii) Thermoplastic material can be softened, hardened or resoftened repeatedly by application of heat. By alternate heating and cooling, they can be reshaped many times. On the other hand, thermosetting plastic materials, once set and hardened, cannot be remelted or reshaped.
- (iii) Thermoplastic materials can be recycled. Therefore, thermoplastic components are environment friendly. It is not possible to recycle thermosetting plastic material. Disposal of components made of thermosetting plastic material, after their useful life, creates problem.
- (iv) Molecules in linear chain can slide over each other. Therefore, thermoplastic materials are flexible. On the other hand, cross-linked thermosetting materials are more rigid. Their rigidity increases with the number of cross-links.
- (v) Common examples of thermoplastic materials are polyethylene, polypropylene, polyvinylchloride (PVC), polystyrene, polytetrafluoroethylene (PTFE) and nylon. Common examples of thermosetting plastic materials are phenolics, aminos, polyesters, epoxies and phenal-formaldehyde.

As a material for machine component, plastics offer following advantages:

- (i) Plastic materials have low specific gravity resulting in light weight construction. The specific gravity of heaviest plastic is 2.3 compared with 7.8 of cast iron.
- (ii) Plastics have high corrosion resistance in any atmospheric condition. This is the most important advantage of plastic materials over metals. Many varieties of plastic materials are acid—resistant and can endure chemicals for long period of time. PVC has excellent resistance to acids and alkalies.
- (iii) Some plastic materials have low coefficient of friction and self lubricating property. The coefficient of friction of polytetrafluoroethylene, commonly called Teflon, is as low as 0.04. Such materials are ideally suitable for bearings.
- (iv) Fabrication of plastic components is easy. Raw material is available in the form of powders, granules or compressed pills. The raw material is converted into plastic parts by compression moulding, injection moulding, transfer moulding or extrusion process. Compression moulding is commonly used for components made of thermosetting plastic materials. Injection moulding is widely used for parts made of thermoplastics. Complicated parts performing several functions can be moulded from plastic material in a single operation.

Plastic materials have following disadvantages:

- (i) Plastic material has poor tensile strength compared with other construction materials. The tensile strength of plastic materials varies from  $10 \text{ N/mm}^2$  to  $80 \text{ N/mm}^2$ .

- (ii) Mechanical properties of engineering metals do not vary much within the range of ambient temperatures encountered in practice. For many polymers, particularly thermoplastic materials, the mechanical properties vary considerably with temperature in the ambient region. For example, a thermoplastic material may have tensile strength of  $70 \text{ N/mm}^2$  at  $0^\circ\text{C}$ , falling to  $40 \text{ N/mm}^2$  at  $25^\circ\text{C}$  and further to  $10 \text{ N/mm}^2$  at  $80^\circ\text{C}$ .
- (iii) Number of polymeric materials display viscoelastic mechanical behaviour. These materials behave like a glass at low temperatures, a rubbery solid at intermediate temperatures and a viscous liquid as the temperature is further increased. Therefore, such materials are elastic at low temperature and obey Hooke's law and at high temperatures liquid like behaviour prevails. At intermediate temperatures, the rubber like solid state exhibits combined mechanical characteristics of these two extremes. This condition is called viscoelasticity.
- (iv) Many plastic materials are susceptible to time-dependent deformation when the stress level is maintained constant. Such deformation is called creep. This type of deformation is significant even at room temperature and under moderate stresses which are even below the yield strength of the material. Due to creep, a machine component of plastic material under load may acquire a permanent set even at room temperature.

Although a large number of plastics are developed, we will consider few materials in this article. These materials are mainly used for machine components. The names in the bracket indicate popular trade names of the material.

- (i) Polyamide (nylon, capron nylon, Zytel, Fosta)  
Polyamide is thermoplastic material. It has excellent toughness and wear resistance. The coefficient of friction is low. It is used for gears, bearings, conveyor rollers and automotive cooling fans.
- (ii) Low density polyethylene (Polythene)  
It is thermoplastic material. It is flexible and tough, light weight, easy to process and low cost material. It is used for gaskets, washers and pipes.
- (iii) Acetal (Delrin)  
It is thermoplastic material. It is a strong engineering material with exceptional dimensional stability. It has low coefficient of friction and high wear resistance. It is used for self-lubricating bearings, cams and running gears.
- (iv) Polyurethane (Duthane, Texin)  
It is thermoplastic material. It is tough, abrasion-resistant and impact-resistant material. It has good dimensional properties and self lubricating characteristics. It is used for bearings, gears, gaskets and seals.
- (v) Polytetrafluoroethylene (Teflon)  
It is thermoplastic material. It has low coefficient of friction and self-lubricating characteristics. It can withstand a wide range of temperature from  $-260$  to  $+250^\circ\text{C}$ . It is ideally suitable for self lubricating bearings.

## (vi) Phenolic

It is thermosetting plastic material. It is low cost with good balance of mechanical and thermal properties. It is used in clutch and brake lining as filler material. Glass reinforced phenolic is used for pulleys and sheaves.

The mechanical properties of plastic materials are given in Table 2.18.

**Table 2.18** Mechanical properties of plastics

<i>Material</i>	<i>Specific gravity</i>	<i>Tensile strength (N/mm<sup>2</sup>)</i>	<i>Compressive strength (N/mm<sup>2</sup>)</i>
Polyamide	1.04–1.14	70	50–90
Low density Polythene	0.92–0.94	7–20	–
Acetal	1.41–1.42	55–70	–
Polyurethane	1.21–1.26	35–60	25–80
Teflon	2.14–2.20	10–25	10–12
Phenolic	1.30–1.90	30–70	—

## 2.25 FIBRE REINFORCED PLASTICS

Fibre Reinforced Plastic (FRP) is a composite material in which the low strength of the polymeric material is increased by means of high strength fibres. There are two main constituents of fibre reinforced plastics, viz. *matrix* and *fibres*. The function of the matrix is to provide a rigid base to hold the strong fibres in correct position. The function of the fibres is to transmit the load acting on the component. The bond between the surface of the fibres and surrounding matrix is usually chemical. The matrix protects the fibres from surface damage and from the action of environment. The fibres used in composite should be long enough so that the bonding force between the surface of the fibre and surrounding matrix is greater than the tensile strength of the fibre.

Two types of fibres are widely used viz. glass and carbon fibres. The advantages of glass reinforced plastics (GRP) are as follows:

- (i) Glass can be easily drawn into fibres from molten state.
- (ii) Glass is cheaper and readily available material.
- (iii) Glass fibres are relatively strong.
- (iv) Glass is chemically inert with respect to plastic matrix materials.

The disadvantages of glass reinforced plastic are as follows:

- (i) Glass reinforced plastics have poor rigidity and stiffness.
- (ii) Their applications are limited upto a temperature of 300°C.

Glass reinforced plastics are used for automotive bodies, pipes, valve bodies, pump casings and storage containers. They are more popular for vehicle bodies due to low specific gravity with resultant lightweight construction.

The advantages of Carbon Reinforced Plastics (CRP) are as follows:

- (i) Carbon fibre has maximum strength compared with all other fibre materials.



## 2.26 NATURAL AND SYNTHETIC RUBBERS

Natural rubber is obtained from rubber latex—a milky liquid obtained from certain tropical trees. It is a low—cost elastomer. Different varieties of rubber are obtained by adding carbon, silica and silicates. Vulcanised rubber is obtained by adding sulphur, which is followed by heating. Addition of carbon makes the rubber hard. Natural rubber, in hard and semi-hard conditions, is used for belts, bushes, flexible tubes and vibration mounts. It is also used for production of coatings, protective films and adhesives. Rubber coatings provide protection in a chemical environment.

Synthetic rubber has properties similar to those of natural rubber. They are thermoplastics and thermo-setting plastics. They are, however, costlier than natural rubber. A few application of synthetic rubbers are as follows:

- (i) Chloroprene (Neoprene): conveyor and V belts, brake diaphragms and gaskets.
- (ii) Nitrile Butadiene (NBR): bushes for flexible coupling and rubber rollers.
- (iii) Polysulfide (Thikol): gaskets, washers and diaphragms.
- (iv) Chlorosulfonyl polyethylene (Hypalon): tank lining, high temperature conveyor belts, seals and gaskets.
- (v) Silicone: seals, gaskets and O-rings.

---

### *Review Questions*

---

- 2.1 (a) Draw stress-strain diagram for the ductile material and show the following points on the curve:
    - (i) Proportional limit
    - (ii) Elastic limit
    - (iii) Upper and lower yield points
    - (iv) Ultimate strength point
    - (v) Breaking point.
  - (b) Sketch stress-strain diagrams for mild steel and cast iron and compare them.
  - (c) Draw stress-strain diagram for ductile material. How will you determine following properties from the diagram?
    - (i) Modulus of elasticity
    - (ii) Percentage elongation
    - (iii) Percentage reduction in area
    - (iv) Modulus of resilience
    - (v) Modulus of toughness.
  - (d) Draw stress-strain diagram for hard steels which do not exhibit yield point and explain the determination of yield stress by offset method.
  - (e) How will you determine proof stress and proof load ?
  - (f) Why percentage elongation is considered as an index of quality of the material?
- 2.2 (a) What do you understand by mechanical properties of materials?
  - (b) Define following properties of materials:
    - (i) Strength
    - (ii) Elasticity
    - (iii) Plasticity
    - (iv) Stiffness

- (c) Explain with neat sketches the general principles in design of castings.
- 2.7 (a) Define cast iron.
- (b) What is the basic difference between cast iron and steel on the basis of carbon content?
- (c) State any two disadvantages of cast iron compared with steel.
- (d) Explain the following:
- (i) Grey cast iron
  - (ii) Malleable cast iron
  - (iii) Spheroidal graphite cast iron. State their applications.
- (e) What do you understand by following designations of cast iron?:
- (i) FG 200
  - (ii) WM 340
  - (iii) BM 310
  - (iv) PM 540
  - (v) SG 700/2
- (f) How will you designate the following varieties of cast iron as per Indian standards?
- (i) Grey cast iron with minimum tensile strength of  $300 \text{ N/mm}^2$ .
  - (ii) Blackheart malleable cast iron with minimum tensile strength of  $350 \text{ N/mm}^2$ .
  - (iii) Whiteheart malleable cast iron with minimum tensile strength of  $400 \text{ N/mm}^2$ .
  - (iv) Pearlitic malleable cast iron with minimum tensile strength of  $600 \text{ N/mm}^2$ .
  - (v) Spheroidal graphite cast iron with minimum tensile strength of  $900 \text{ N/mm}^2$  and elongation of 2 per cent
- [Ans. (i) FG 300, (ii) BM 350, (iii) WM 400, (iv) PM 600, (v) SG 900/2 ]
- (g) Suggest suitable materials for following machine parts:
- (i) Engine cylinder
  - (ii) Poessure plate of clutch
  - (iii) Flywheel
  - (iv) Lathe bed
  - (v) Casing of centrifugal pump
  - (vi) Brake drum
  - (vii) Housing of gear box
  - (viii) Brake shoe of railway wagon
  - (ix) Pedal
  - (x) Pipe fittings.
- 2.8 (a) What do you understand by following designations of steel ?:
- (i) Fe 320
  - (ii) FeE 200
  - (iii) 40C8
  - (iv) 40Cr4
  - (v) 30Ni16Cr5
  - (vi) X15Cr25Ni12.
- (b) How will you designate following varieties of steel ?:
- (i) Plain carbon steel with minimum tensile strength of  $320 \text{ N/mm}^2$ .
  - (ii) Plain carbon steel with minimum yield stress of  $200 \text{ N/mm}^2$ .
  - (iii) Plain carbon steel with 0.4 % carbon and 0.8% manganese
  - (iv) Alloy steel with following composition :  
carbon = 0.35% to 0.45%  
chromium = 0.90% to 1.1%
  - (v) Alloy steel with following composition :  
carbon = 0.12 to 0.20%  
nickel = 0.80 to 1.2%

chromium = 0.60 to 1.0%

[Ans. (i) Fe 320, (ii) FeE 200, (iii) 40C8, (iv) 40Cr4, (v) 16Ni4Cr3]

- (c) Distinguish between mild steel, machinery steel and tool steel.
- (d) What is the percentage of carbon in mild steel ?
- (e) Suggest suitable material for following machine parts:
- |                          |                         |
|--------------------------|-------------------------|
| (i) Machine tool spindle | (ii) Transmission shaft |
| (iii) Axle               | (iv) Key                |
| (v) High strength bolt   | (vi) Gear               |
| (vii) Helical spring     | (viii) Tie rod          |
- 2.9 (a) What is the effect of adding sulphur in carbon steels ?
- (b) What do you understand by machinability ?
- (c) What is free cutting steel ? Give its two applications.
- (d) Define alloy steel. Name the various alloying elements for steel.
- (e) Compare plain carbon steels with alloy steels.
- (f) State the effect of following alloying elements in steel :
- |                |                |
|----------------|----------------|
| (i) Silicon    | (ii) Manganese |
| (iii) Nickel   | (iv) Chromium  |
| (v) Molybdenum | (vi) Tungsten. |
- 2.10 (a) What do you understand by following overseas designation:
- |                                       |
|---------------------------------------|
| (i) A.S.T.M. Class 20 grey cast iron. |
| (ii) D.I.N. GG-18 grey cast iron      |
| (iii) S.A.E. 3140 steel.              |
- (b) What do you understand by following heat treatments? Where do you use them?
- |                 |                  |
|-----------------|------------------|
| (i) Annealing   | (ii) Normalising |
| (iii) Quenching | (iv) Tempering.  |
- (c) State the objectives and applications of case hardened components.
- (d) Explain the different methods of case-hardening. Also, state their advantages and limitations.
- 2.11 (a) Compare cast steel with wrought steel.
- (b) Compare cast steel with cast iron.
- (c) How will you designate the following varieties of cast steel ?:
- |  |
|--|
| (i) Carbon steel casting with ultimate tensile strength of $400 \text{ N/mm}^2$ and yield stress of $200 \text{ N/mm}^2$ . |
| (ii) High tensile steel casting with ultimate tensile strength of $1030 \text{ N/mm}^2$ .                                  |
- [Ans. (i) 200-400, (ii) CS 1030 ]
- (d) What do you understand by following designations of cast steel ?:
- |             |             |
|-------------|-------------|
| (i) 340-570 | (ii) CS 700 |
|-------------|-------------|
- (e) Give two applications of carbon steel castings and high tensile steel castings.
- 2.12 (a) Explain any three advantages of aluminium alloys as material for machine components.
- (b) What are the drawbacks of aluminium alloys compared with steel ?

- (c) What do you understand by following designations of aluminium alloys ?:
- (i) 4652                                      (ii) 4450  
 (iii) 24345                                      (iv) 54300
- (d) How will you designate an alloy of aluminium with 9.8% copper, 1.0% iron and 0.25% magnesium ?
- (e) Give any three applications of wrought aluminium alloy.
- (f) Give any three applications of cast aluminium alloy.
- 2.13 (a) Why copper alloys are preferred instead of pure copper for structural components ?
- (b) State any three advantages of brass as a material for machine parts. Give its applications.
- (c) State the relationship between strength and ductility of brass with its zinc content.
- (d) State any three advantages of bronze component. What is the limiting factor for use of bronze for machine parts ?
- (e) State the advantages and applications of following varieties of bronze:
- (i) Aluminium bronze,                      (ii) Phosphor bronze ; and  
 (iii) Tin bronze.
- (f) What is the composition of gun metal ? What are its advantages and applications ?
- (g) What is monel metal ? Why is it used in chemical equipment ?
- 2.14 (a) What are the advantages and drawbacks of die casting process ?
- (b) Name any two die casting alloys.
- 2.15 (a) What is a ceramic ? Give examples of modern engineering ceramic.
- (b) Explain any three advantages of ceramic.
- (c) Discuss any three drawbacks of ceramic.
- (d) What are the applications of modern ceramic components ?
- 2.16 (a) Explain the following terms :
- (i) Monomer,                                      (ii) Polymer, and  
 (iii) Plastic.
- (b) Give any two examples of monomer and corresponding polymer with chemical composition.
- (c) Explain, with the help of example, how lengthening of polymer chain can result in different materials.
- (d) What are filler, plasticizer, flame retardant and pigment ? What is their purpose in plastic materials ?
- (e) Compare thermoplastic with thermosetting plastics. Give their examples.
- (f) Explain any four advantages and four disadvantages of plastic as a material for machine parts.
- (g) State the advantages and applications of following varieties of plastic material:
- (i) Nylon,    (ii) Polythene,  
 (iii) Teflon, and                                  (iv) Phenolic.

- 2.17 (a) What is Fibre Reinforced Plastic (FRP) ? What are its constituents?  
(b) State the advantages and disadvantages of Glass Reinforced Plastic (GRP)? Give its applications.  
(c) State the advantages and disadvantages of Carbon Reinforce Plastic (CRP)? Give its application.  
(d) What are the advantages of fibre reinforced plastic as a material for structural parts? What are the disadvantages?  
(e) Explain the scope of FRP for machine parts.
- 2.18 (a) Explain the difference between natural and synthetic rubber.  
(b) Name the machine components made of rubber.

- (iii) Variations in the dimensions of the component due to imperfect workmanship.

In addition to these factors, the number of assumptions made in design analysis, in order to simplify the calculations, may not be exactly valid in working conditions. The factor of safety ensures against these uncertainties and unknown conditions.

The magnitude of factor of safety depends upon following factors:

**1. Effect of failure** Sometimes, the failure of machine element involves only a little inconvenience or loss of time, e.g. failure of the ball bearing in gear box. On the other hand in some cases, there is substantial financial loss or danger to the human life, e.g. failure of the valve in pressure vessel. The factor of safety is high in applications where failure of machine part may result in serious accidents.

**2. Type of load** The factor of safety is low when the external force acting on the machine element is static, i.e. a load which does not vary in magnitude or direction with respect to time. On the other hand, a higher factor of safety is selected when the machine element is subjected to impact load. This is due to the fact that impact load is suddenly applied to the machine component, usually at high velocities.

**3. Degree of accuracy in force analysis** When the forces acting on the machine component are precisely determined, a low factor of safety can be selected. On the contrary, a higher factor of safety is necessary when the machine component is subjected to a force whose magnitude or direction is uncertain and unpredictable.

**4. Material of component** When the component is made of homogeneous ductile material like steel, yield strength is the criterion of failure. Factor of safety is usually small in such cases. On the other hand, cast iron component has non-homogeneous structure and a higher factor of safety based on ultimate tensile strength is chosen.

**5. Reliability of component** In certain applications like continuous process equipment, power stations or defence equipment, high reliability of machine parts is expected. The factor of safety increases with increasing reliability.

**6. Cost of component** As the factor of safety increases, dimensions of component, material requirement and cost increase. Factor of safety is low for cheap machine parts.

**7. Testing of machine element** A low factor of safety can be chosen when the machine component can be tested under actual conditions of service and operation. A higher factor of safety is necessary, when it is not possible to test the machine part or where there is deviation between test conditions and actual service conditions.

**8. Service conditions** When the machine element is likely to operate in corrosive atmosphere or high temperature environment, higher factor of safety is necessary.

- (v) Certain components, such as piston rod, power screws or studs, are designed on the basis of buckling consideration. Buckling is elastic instability, which results in a sudden large lateral deflection. The critical buckling load, when buckling takes place, depends upon yield strength, modulus of elasticity, end conditions and radius of gyration of the column. The recommended factor of safety is 3 to 6 based on critical buckling load of such components.

The above mentioned values of factor of safety are based on past experience. They are applicable under normal circumstances. However, higher factor of safety is chosen under the following conditions:

- (i) The magnitude and nature of external forces acting on the machine component cannot be precisely estimated.
- (ii) It is likely that the material of machine component has non-homogeneous structure.
- (iii) The machine component is subjected to impact force in service.
- (iv) There is possibility of residual stresses in the machine component.
- (v) The machine component is working in corrosive atmosphere.
- (vi) The machine part is subjected to high temperatures during operation.
- (vii) The failure of machine part may hazard the lives of people (hoist, lifting machinery and boilers) and substantial loss to property.
- (viii) It is not possible to test the machine component under actual conditions of service and there is variation in actual conditions and standard test conditions.
- (ix) Higher reliability is demanded in applications like components of aircrafts.
- (x) There is possibility of abnormal variation in external load on some occasions.
- (xi) The quality of manufacture of the machine part is poor.
- (xii) The exact mode of failure of the component is unpredictable.
- (xiii) There is stress concentration in machine component.

Higher factor of safety increases the reliability of the component. However, it increases the dimensions, the volume of material and consequently the cost of machine component. In recent years, attempts have been made to obtain precise values of factor of safety based on statistical considerations and reliability analysis.

### **3.2 TENSILE AND COMPRESSIVE STRESSES**

When a mechanical component is subjected to an external static force, a resisting force is set up within the component. The internal resisting force per unit area of the component is called stress. The stresses are called tensile when the fibres of the component tend to elongate due to the external force. On the other hand, when the fibres tend to shorten due to the external force, the stresses are called

compressive stresses. A tension rod subjected to an external force  $P$  is shown in Fig. 3.1. The tensile stress is given by

$$\sigma_t = \frac{P}{A} \quad (3.3)$$

where

$\sigma_t$  = tensile stress ( $\text{N}/\text{mm}^2$ )

$P$  = external force (N)

$A$  = cross-sectional area ( $\text{mm}^2$ )

The strain is given by

$$\varepsilon = \frac{\delta}{l} \quad (3.4)$$

where

$\varepsilon$  = strain ( $\text{mm}/\text{mm}$ )

$\delta$  = elongation of tension rod (mm)

$l$  = original length of the rod (mm)

According to Hooke's law, the stress is directly proportional to the strain, within elastic limit. Therefore,

$$\sigma_t \propto \varepsilon$$

$$\text{or} \quad \sigma_t = E \varepsilon \quad (3.5)$$

where

$E$  = modulus of elasticity ( $\text{N}/\text{mm}^2$ )

Substituting Eqs (3.3) and (3.4) in the above expression,

$$\delta = \frac{Pl}{AE} \quad (3.6)$$

A component subjected to a compressive force is shown in Fig. 3.2. The compressive stress  $\sigma_c$  is given by

$$\sigma_c = \frac{P}{A} \quad (3.7)$$

The following assumptions were made in the above analysis of stress and strain:

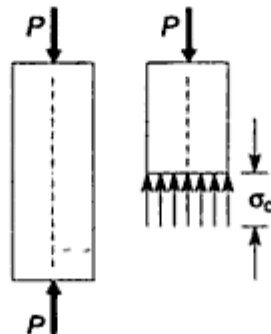

Fig. 3.2 Compressive Stress

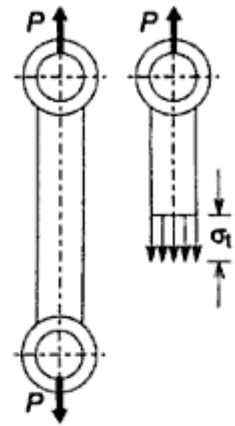

Fig. 3.1 Tensile Stress



- (i) The material is homogeneous,
- (ii) The load is gradually applied,
- (iii) The line of action of force  $P$  passes through the geometric axis of the cross-section, and
- (iv) The cross-section is uniform and free from the effects of stress concentration.

### 3.3 SHEAR STRESS AND SHEAR STRAIN

When the external force acting on a component tends to slide the adjacent planes with respect to each other, the resulting stresses on these planes are called direct shear stresses. Two plates held together by means of a rivet are shown in Fig. 3.3 (a). The average shear stress in the rivet is given by

$$\tau = \frac{P}{A} \quad (3.8)$$

where

$\tau$  = shear stress

$A$  = cross-sectional area of the rivet ( $\text{mm}^2$ )

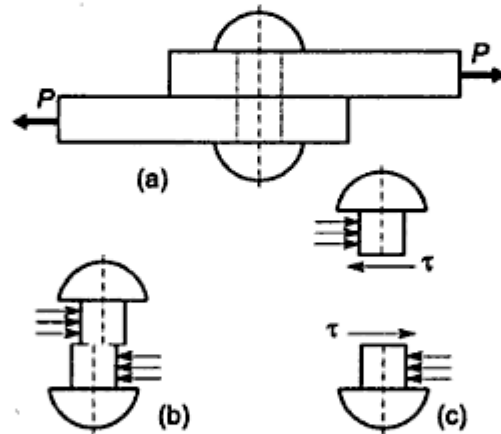

**Fig. 3.3** (a) Riveted Joint (b) Shear Deformation (c) Shear Stress

A plane, rectangular element, cut from the component and subjected to shear force, is shown in Fig. 3.4 (a). Shear stresses cause a distortion in the original right angles. The shear strain ( $\gamma$ ) is defined as the change in the right angle of a shear element. Within the elastic limit, the stress-strain relationship is given by

$$\tau = G\gamma \quad (3.9)$$

where

$\gamma$  = shear strain (radians)

$G$  = modulus of rigidity ( $\text{N}/\text{mm}^2$ )

The relationship between the modulus of elasticity, the modulus of rigidity and the Poisson's ratio is given by

$$E = 2G(1 + \mu) \quad (3.10)$$

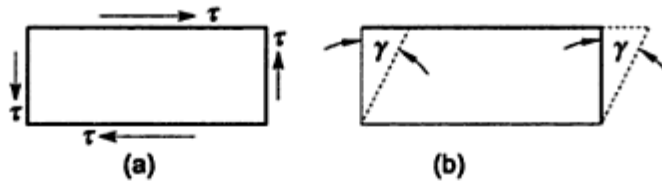

Fig. 3.4 (a) Element Loaded in Pure Shear (b) Shear Strain

where  $\mu$  is Poisson's ratio. The Poisson's ratio is the ratio of strain in the lateral direction to that in the axial direction. The permissible shear stress is given by

$$\tau = \frac{S_{sy}}{(fs)} \tag{3.11}$$

where

$S_{sy}$  = yield strength in shear ( $N/mm^2$ )

It will be proved at a later stage that the yield strength in shear is 50% of the yield strength in tension, according to principal shear stress theory of failure.

### 3.4 STRESSES DUE TO BENDING MOMENT

A straight beam subjected to a bending moment  $M_b$  is shown in Fig. 3.5 (a). The beam is subjected to a combination of tensile stress on one side of the neutral axis and compressive stress on the other. The distribution of stresses can be imagined by taking a thick leather belt and bending it. Cracks will appear on the outer surface, while folds on the inside. Therefore, the outside fibres are in tension, while the inside fibres in compression. The bending stress at any fibre is given by

$$\sigma_b = \frac{M_b y}{I} \tag{3.12}$$

where

$\sigma_b$  = bending stress at a distance of  $y$  from the neutral axis ( $N/mm^2$ )

$M_b$  = applied bending moment (N-mm)

$I$  = moment of inertia of the cross-section about the neutral axis ( $mm^4$ )

The bending stress is maximum in a fibre which is farthest from the neutral axis. The distribution of stresses is linear and the stress is proportional to the distance from the neutral axis.

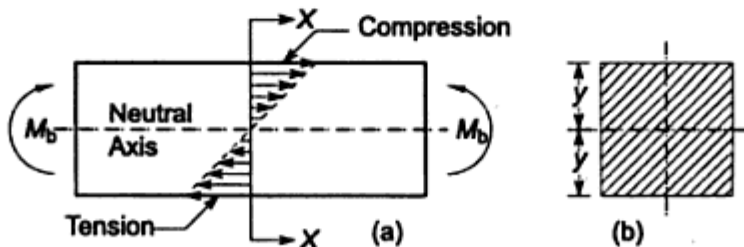

Fig. 3.5 (a) Distribution of Bending Stresses (b) Section at XX

diagram, which is illustrated in Fig. 3.7. For positive bending, the bending moment diagram is constructed on positive side of  $Y$ -axis. For negative bending, the diagram is on negative side of  $Y$ -axis. There is simple way to remember positive bending. Imagine the crescent shaped moon and it is positive bending.

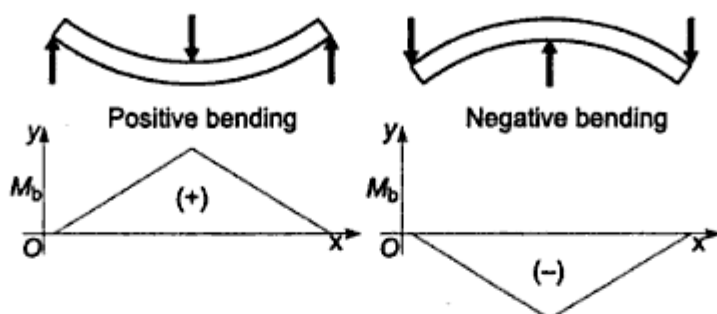

Fig. 3.7 Sign Convention for Bending Moment

### 3.5 STRESSES DUE TO TORSIONAL MOMENT

A transmission shaft, subjected to an external torque, is shown in Fig. 3.8(a). The internal stresses, which are induced to resist the action of twist, are called torsional shear stresses. The torsional shear stress is given by,

$$\tau = \frac{M_t r}{J} \quad (3.17)$$

where,

$\tau$  = torsional shear stress at the fibre ( $\text{N}/\text{mm}^2$ ).

$M_t$  = applied torque ( $\text{N}\cdot\text{mm}$ ).

$r$  = radial distance of the fibre from the axis of rotation ( $\text{mm}$ ).

$J$  = polar moment of inertia of the cross-section about the axis of rotation ( $\text{mm}^4$ ).

The distribution of torsional shear stresses is shown in Fig. 3.8 (b). The stress is maximum at the outer fibre and zero at the axis of rotation. The angle of twist is given by,

$$\theta = \frac{M_t l}{JG} \quad (3.18)$$

where,

$\theta$  = angle of twist (radians)

$l$  = length of the shaft ( $\text{mm}$ )

Equations (3.17) and (3.18) are based on the following assumptions:

- (i) The shaft is straight with a circular cross-section,
- (ii) A plane transverse section remains plane after twisting, and
- (iii) The material is homogeneous, isotropic and obeys Hooke's law.

The polar moment of inertia of a solid circular bar of diameter  $d$  is given by

$$J = \frac{\pi d^4}{32} \quad (3.19)$$

stress or torsional shear stress. The analysis is simple but approximate because number of factors such as principal stresses, stress concentration, reversal of stresses are neglected. Therefore, a higher factor of safety up to 5 is taken to account for these factors.

- (ii) It is incorrect to assume allowable stress as data for design. The allowable stress is to be obtained from published values of ultimate tensile strength and yield strength for a given material by Eqs (3.1) and (3.2) respectively.
- (iii) The maximum shear stress theory is discussed in Article 3.19. According to this theory, the yield strength in shear is 50% of yield strength in tension. Therefore,

$$S_{sy} = 0.5 S_{yt} \quad (3.24)$$

and the permissible shear stress ( $\tau$ ) is given by

$$\tau = \frac{S_{sy}}{(fs)}$$

The above value of allowable shear stress is used in determination of dimensions of the component.

The design analysis in this chapter is approximate and incomplete. The purpose of such problems is to illustrate the application of design equations to find out the geometric dimensions of the component. In practice, much more stress analysis is involved in design of machine parts.

### Example 3.1

Two plates, subjected to a tensile force of 50 kN, are fixed together by means of three rivets as shown in Fig. 3.9 (a). The plates and rivets are made of plain carbon steel 10C4 with a tensile yield strength of 250 N/mm<sup>2</sup>. The yield strength in shear is 50% of the tensile yield strength, and the factor of safety is 2.5. Neglecting stress concentration, determine:

- (i) the diameter of the rivets, and
- (ii) the thickness of the plates.

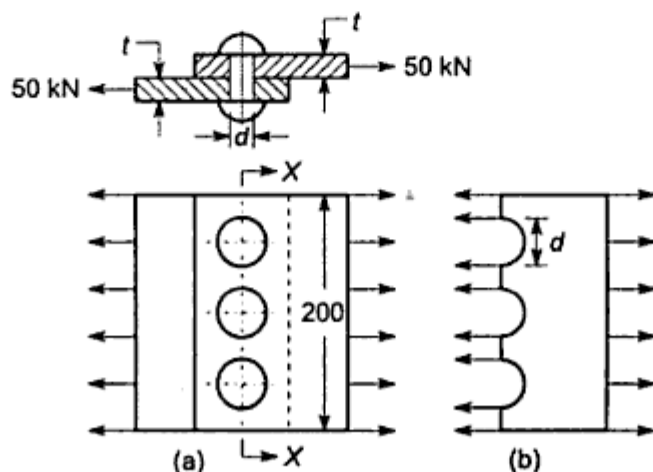

Fig. 3.9 (a) Riveted Joint (b) Tensile Stress in Plate

**Solution**

For rivets,

$$\tau = \frac{S_{sy}}{(fs)} = \frac{0.50 (S_{yt})}{(fs)} = \frac{0.50 (250)}{(2.5)} = 50 \text{ N/mm}^2$$

Since there are three rivets,

$$3 \left[ \frac{\pi}{4} d^2 \right] \tau = P$$

$$\text{or } 3 \left[ \frac{\pi}{4} d^2 \right] 50 = 50 \times 10^3$$

$$\text{or } d = 20.60 \text{ or } 22 \text{ mm} \quad (\text{i})$$

For plates,

$$\sigma_t = \frac{S_{yt}}{(fs)} = \frac{250}{2.5} = 100 \text{ N/mm}^2$$

As shown in Fig. 3.9 (b),

$$\sigma_t (200 - 3d) t = P$$

$$\text{or } 100(200 - 3 \times 22) t = 50 \times 10^3$$

$$\text{or } t = 3.73 \text{ or } 4 \text{ mm} \quad (\text{ii})$$

**Example 3.2**

A link, shown in Fig. 3.10, is made of grey cast iron FG150. It transmits a pull  $P$  of 10 kN. Assuming that the link has square cross-section ( $b = h$ ) and using a factor of safety of 5, determine the dimensions of the cross-section of the link.

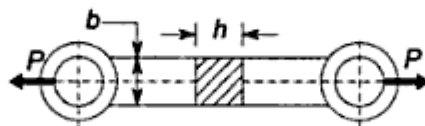

**Fig. 3.10**

**Solution**

Allowable tensile stress is given by,

$$\sigma_t = \frac{S_{ut}}{(fs)} = \frac{150}{5} = 30 \text{ N/mm}^2$$

Since,

$$\sigma_t = \frac{P}{A}$$

$$30 = \frac{10 \times 10^3}{(b \times h)} = \frac{10 \times 10^3}{b^2}$$

or  $b = 18.36$  or  $20$  mm

The cross-section of the link is  $20 \times 20$  mm.

### Example 3.3

The piston of a double acting, condensing steam engine is illustrated in Fig. 3.11. The piston rod has a screwed end. The diameter of the cylinder is  $300$  mm. The maximum steam pressure in the cylinder is  $0.85$  N/mm<sup>2</sup> gauge and the back pressure of the steam is  $0.02$  N/mm<sup>2</sup> absolute. The piston rod is made of plain carbon steel 40C8 ( $S_{yt} = 380$  N/mm<sup>2</sup>) and the factor of safety is  $5$ . Determine the diameter of piston rod.

State the assumptions, you make.

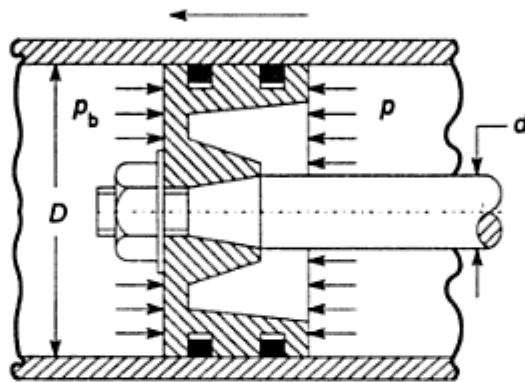

Fig. 3.11

**Solution** The analysis of this problem is based on following assumptions:

- (i) As the piston moves in forward direction, as shown in Fig. 3.11, the piston rod is subjected to tensile stress. The piston rod is designed on the basis of this tensile stress. During the return stroke, the piston rod is subjected to compressive stress. Since the compressive strength of material is always very high compared with its tensile strength, the compressive stress in piston rod during return stroke is neglected.
- (ii) The maximum steam pressure ( $p$ ) acts on the following effective area of piston,

effective area = area of piston – area of piston rod

$$= \left[ \frac{\pi}{4} D^2 - \frac{\pi}{4} d^2 \right]$$

The reduction in effective area of piston due to piston rod is neglected.

- (iii) The atmospheric pressure is assumed as  $0.103$  N/mm<sup>2</sup>. Therefore,

$$p = 0.85 + 0.103 = 0.953 \text{ N/mm}^2$$

The maximum tensile force on piston rod is given by

$$P = \frac{\pi}{4} D^2 (p - p_b)$$

$$= \frac{\pi}{4} (300)^2 (0.953 - 0.02)$$

$$= 65\,949.88 \text{ N}$$

The permissible tensile stress is given by,

$$\sigma_t = \frac{S_{yt}}{(fs)} = \frac{380}{5} = 76 \text{ N/mm}^2$$

Also,

$$\sigma_t = \frac{P}{A}$$

Therefore,

$$76 = \frac{65\,949.88}{\left(\frac{\pi}{4} d^2\right)}$$

$$\therefore d = 33.24 \text{ mm}$$

Since the piston rod has screwed end, 33.24 mm is the minimum core diameter of the screw. The nominal diameter of the screw will be more than this value. In addition, a taper is provided to the piston rod. Considering these two factors, the diameter of piston rod is increased to 40mm.

### Example 3.4

A suspension link, used in the bridge, is shown in Fig. 3.12. The plates and the pin are made of plain carbon steel 30C8 ( $S_{yt} = 400 \text{ N/mm}^2$ ) and the factor of safety is 5. The maximum load ( $P$ ) on the link is 100kN. The ratio of width of the link plate to its thickness ( $b/t$ ) can be taken as 5. Calculate:

- (i) Thickness and width of the link plates,
- (ii) Diameter of the knuckle pin,
- (iii) Width of the link plate at the centre line of the pin, and
- (iv) Crushing stress on the pin.

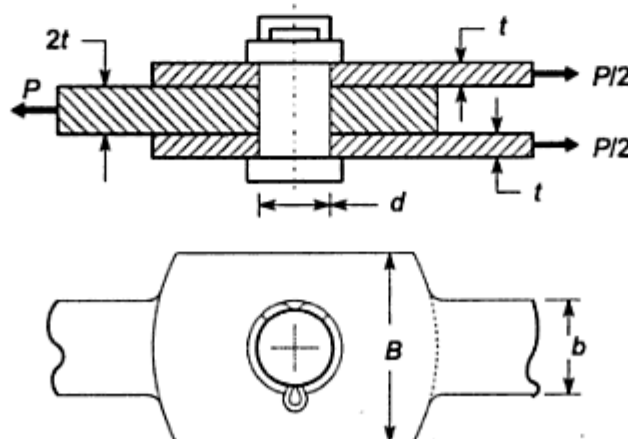

**Fig. 3.12** Suspension Link

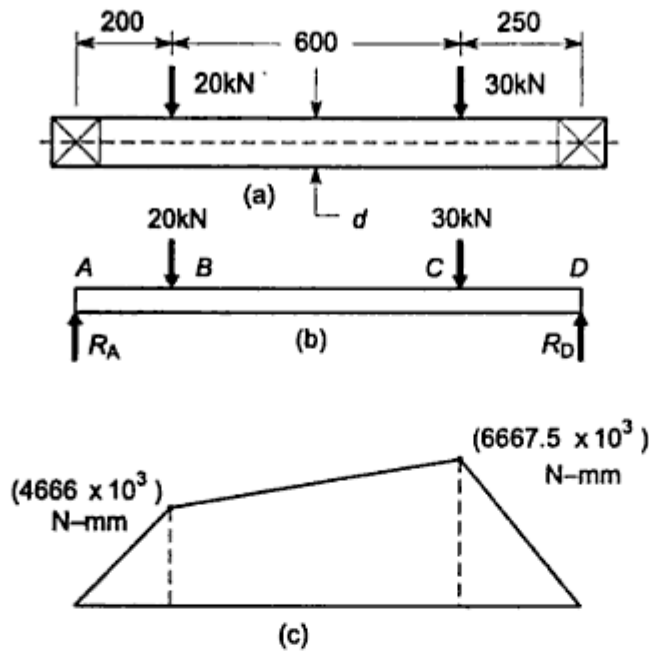

Fig. 3.13

Considering equilibrium of vertical forces,

$$R_A + R_D = 20 + 30$$

$$R_A + 26.67 = 20 + 30$$

$$\therefore R_A = 23.33 \text{ kN}$$

The bending moment diagram is shown in Fig. 3.13(c). The maximum bending moment at C is  $(6667.5 \times 10^3)$  N-mm.

From Eq. (3.12),

$$\sigma_b = \frac{M_b y}{I}$$

From Eq. (3.14),

$$I = \frac{\pi d^4}{64} \quad \text{and} \quad y = \frac{d}{2}$$

Substituting Eq. (3.14) in Eq. (3.12),

$$\sigma_b = \frac{32 M_b}{\pi d^3} \tag{a}$$

The permissible tensile stress is given by,

$$\sigma_t = \frac{S_{yt}}{(fs)} = \frac{400}{5} = 80 \text{ N/mm}^2$$

Substituting above value in Eq. (a),

$$d^3 = \frac{32 M_b}{\pi \sigma_b} = \frac{32 (6667.5 \times 10^3)}{\pi (80)}$$

$$\therefore d = 94.69 \quad \text{or} \quad 95 \text{ mm}$$



**Example 3.7**

A shaft transmits 20kW power and rotates at 500 r.p.m. The material of shaft is 50C4 ( $S_{yt} = 460 \text{ N/mm}^2$ ) and the factor of safety is 2.

- Determine the diameter of shaft on the basis of its shear strength.
- Determine the diameter of shaft on the basis of its torsional rigidity, if the permissible angle of twist is  $3^\circ$  per metre length and modulus of rigidity of shaft material is  $79\,300 \text{ N/mm}^2$ .

**Solution**

$$\begin{aligned} M_t &= \frac{60 \times 10^6 (\text{kW})}{2\pi n} \\ &= \frac{60 \times 10^6 (20)}{2\pi(500)} \\ &= 381\,971.86 \text{ N-mm} \end{aligned}$$

From Eq. (3.24),

$$S_{sy} = 0.5S_{yt} = 0.5(460) = 230 \text{ N/mm}^2$$

and,

$$\tau = \frac{S_{sy}}{(fs)} = \frac{230}{2} = 115 \text{ N/mm}^2$$

From Eq. (3.17),

$$\tau = \frac{M_t r}{J}$$

From Eq. (3.19),

$$J = \frac{\pi d^4}{32}$$

Substituting Eq. (3.19) in Eq. (3.17) and rearranging the terms,

$$d^3 = \frac{16 M_t}{\pi \tau}$$

Substituting numerical values in above equation,

$$d^3 = \frac{16(381\,971.86)}{\pi(115)}$$

$$\therefore d = 25.67 \text{ mm}$$

From Eq. (3.21),

$$\theta = \frac{584 M_t l}{G d^4}$$

$$3 = \frac{584(381\,971.86)(1000)}{79300 d^4}$$

$$\therefore d = 31.12 \text{ mm} \quad (\text{b})$$

### Example 3.8

A hollow shaft is required to transmit 500kW power at 120 r.p.m. The maximum torque is 25% greater than the mean torque. The shaft is made of plain carbon steel 45C8 ( $S_{yt} = 380 \text{ N/mm}^2$ ) and the factor of safety is 3.5. The shaft should not twist more than 1.5 degrees in a length of 3 metres. The internal diameter of shaft is (3/8) times of external diameter. The modulus of rigidity of shaft material is 80 kN/mm<sup>2</sup>. Determine the external diameter of shaft on the basis of its shear strength and on the basis of permissible angle of twist.

#### Solution

$$M_t = \frac{60 \times 10^6 (\text{kW})}{2\pi n}$$

$$M_t = \frac{60 \times 10^6 (500)}{2\pi(120)}$$

$$= 39\,788.74 \times 10^3 \text{ N-mm}$$

The maximum torque is 25% greater than the mean torque. Therefore,

$$M_t = 1.25 (39\,788.74 \times 10^3)$$

$$= 49\,735.92 \times 10^3 \text{ N-mm}$$

From Eq. (3.24),

$$S_{sy} = 0.5 S_{yt} = 0.5(380) = 190 \text{ N/mm}^2$$

$$\tau = \frac{S_{sy}}{(fs)} = \frac{190}{3.5} = 54.29 \text{ N/mm}^2$$

From Eq. (3.20),

$$J = \frac{\pi(d_o^4 - d_i^4)}{32}$$

$$= \frac{\pi}{32} \left[ \left( \frac{8}{3} d_i \right)^4 - d_i^4 \right]$$

$$= 4.8663 d_i^4 \text{ mm}^4$$

From Eq. (3.17),

$$\tau = \frac{M_t r}{J}$$

Substituting values,

$$54.29 = \frac{49\,735.92 \times 10^3 \left( \frac{1}{2} \times \frac{8d_i}{3} \right)}{4.8663d_i^4}$$

$$\therefore d_i = 63.08 \text{ mm}$$

$$d_o = \frac{8d_i}{3} = \frac{8(63.08)}{3} = 168.22 \text{ mm} \quad (\text{i})$$

From Eq. (3.18),

$$\theta = \frac{M_t l}{JG}$$

$$\frac{1.5 \times \pi}{1.80} = \frac{49\,735.62 \times 10^3 (3000)}{(4.8663d_i^4)(80\,000)}$$

$$\therefore d_i = 61.86 \text{ mm}$$

$$d_o = \frac{8d_i}{3} = \frac{8(61.86)}{3} = 164.95 \text{ mm} \quad (\text{ii})$$

### 3.7 COTTER JOINT

Cotter joint is used to connect two co-axial rods, which are subjected to either axial tensile force or axial compressive force. It is, also, used to connect rod on one side with some machine part like crosshead or base plate on the other side. It is not used for connecting shafts that rotate and transmit torque. Typical applications of cotter joint are as follows:

- (i) Joint between the piston rod and the crosshead of steam engine;
- (ii) Joint between the slide spindle and the fork of the valve mechanism;
- (iii) Joint between the piston rod and the tail or pump rod; and
- (iv) Foundation bolt.

The principle of wedge action is used in cotter joint. A cotter is a wedge shaped piece made of steel plate. The joint is tightened and adjusted by means of wedge action of the cotter. The construction of a cotter joint, used to connect two rods-A and B is shown in Fig. 3.15. Rod-A is provided with a socket end, while rod-B with spigot end. The socket end of rod-A fits over the spigot end of rod-B. The socket as well as the spigot is provided with a narrow rectangular slot. A cotter is tightly fitted in this slot passing through the socket and the spigot. The cotter has uniform thickness and the width dimension 'b' is given a slight taper. The taper is usually 1 in 24. The taper is provided for following two reasons:

- (i) When the cotter is inserted in the slot through the socket and the spigot and pressed by means of hammer, it becomes tight due to wedge action. This ensures tightness of joint in operating condition and prevents loosening of the parts.

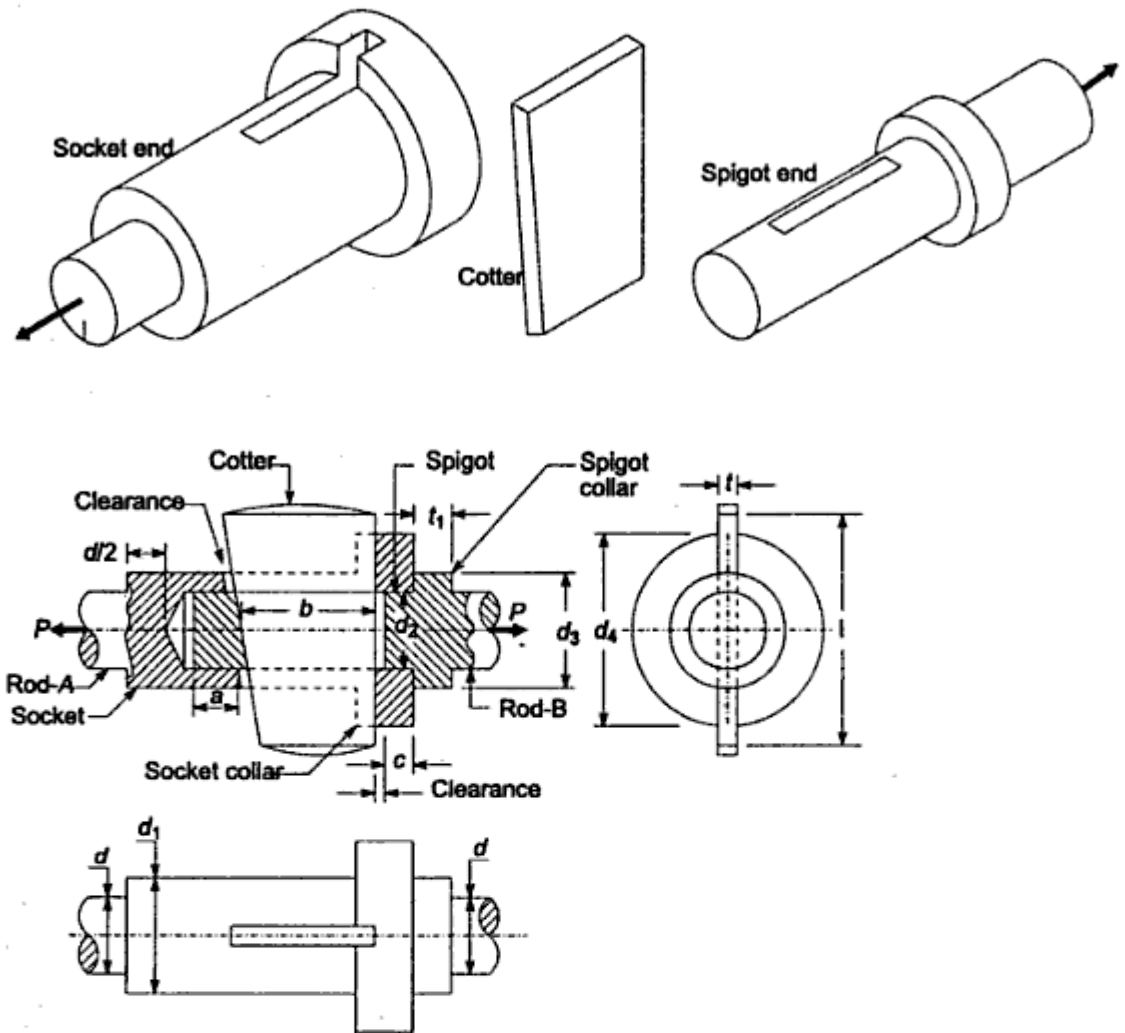

Fig. 3.15 Cotter Joint

(ii) Due to taper shape, it is easy to remove the cotter and dismantle the joint.

The taper of cotter as well as slots is on one side. Machining taper on two sides of a machine part is more difficult than making taper on one side. Also, there is no specific advantage of taper on two sides. A clearance of 1.5 to 3 mm is provided between the slots and the cotter. When the cotter is driven in the slots, the two rods are drawn together until the spigot collar rests on the socket collar. The amount by which the two rods are drawn together is called the 'draw' of the cotter. The cotter joint offers following advantages:

- (i) The assembly and dismantling of parts of the cotter joint is quick and simple. The assembly consists of inserting the spigot end into the socket end and putting the cotter into their common slot. When the cotter is hammered, the rods are drawn together and tightened. Dismantling consists of removing the cotter from the slot by means of a hammer.
- (ii) The wedge action develops very high tightening force, which prevents loosening of parts in service.
- (iii) The joint is simple to design and manufacture.

of failure, one strength equation is written. Finally, these strength equations are used to determine various dimensions of the cotter joint.

### 1. Tensile Failure of Rods

Each rod of diameter  $d$  is subjected to tensile force  $P$ . The tensile stress in the rod is given by,

$$\sigma_t = \frac{P}{\left[ \frac{\pi d^2}{4} \right]}$$

or

$$d = \sqrt{\frac{4P}{\pi\sigma_t}} \quad (3.25-a)$$

where  $\sigma_t$  is permissible tensile stress for the rods.

### 2. Tensile Failure of Spigot

Figure 3.17(a) shows the weakest cross-section at  $XX$  of the spigot end, which is subjected to tensile stress.

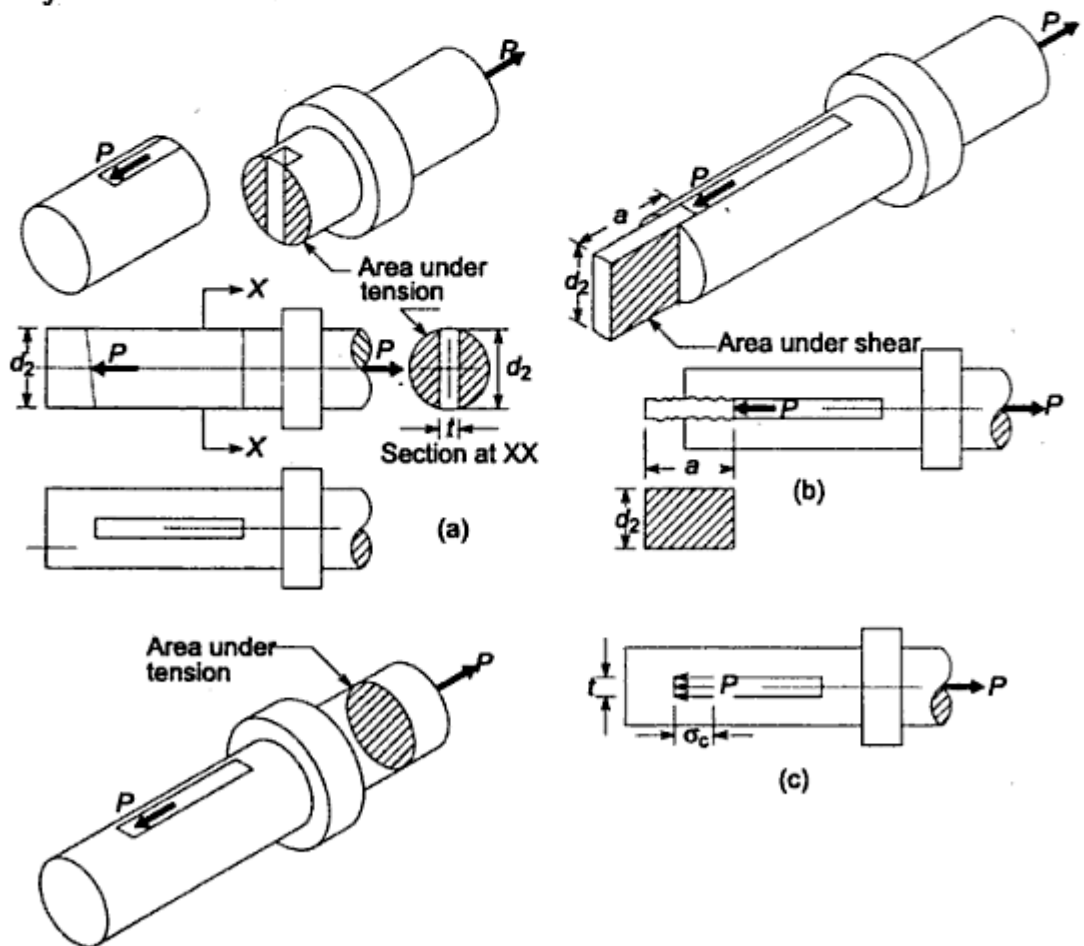

Fig. 3.17 Stresses in Spigot end (a) Tensile Stress (b) Shear Stress (c) Compressive Stress

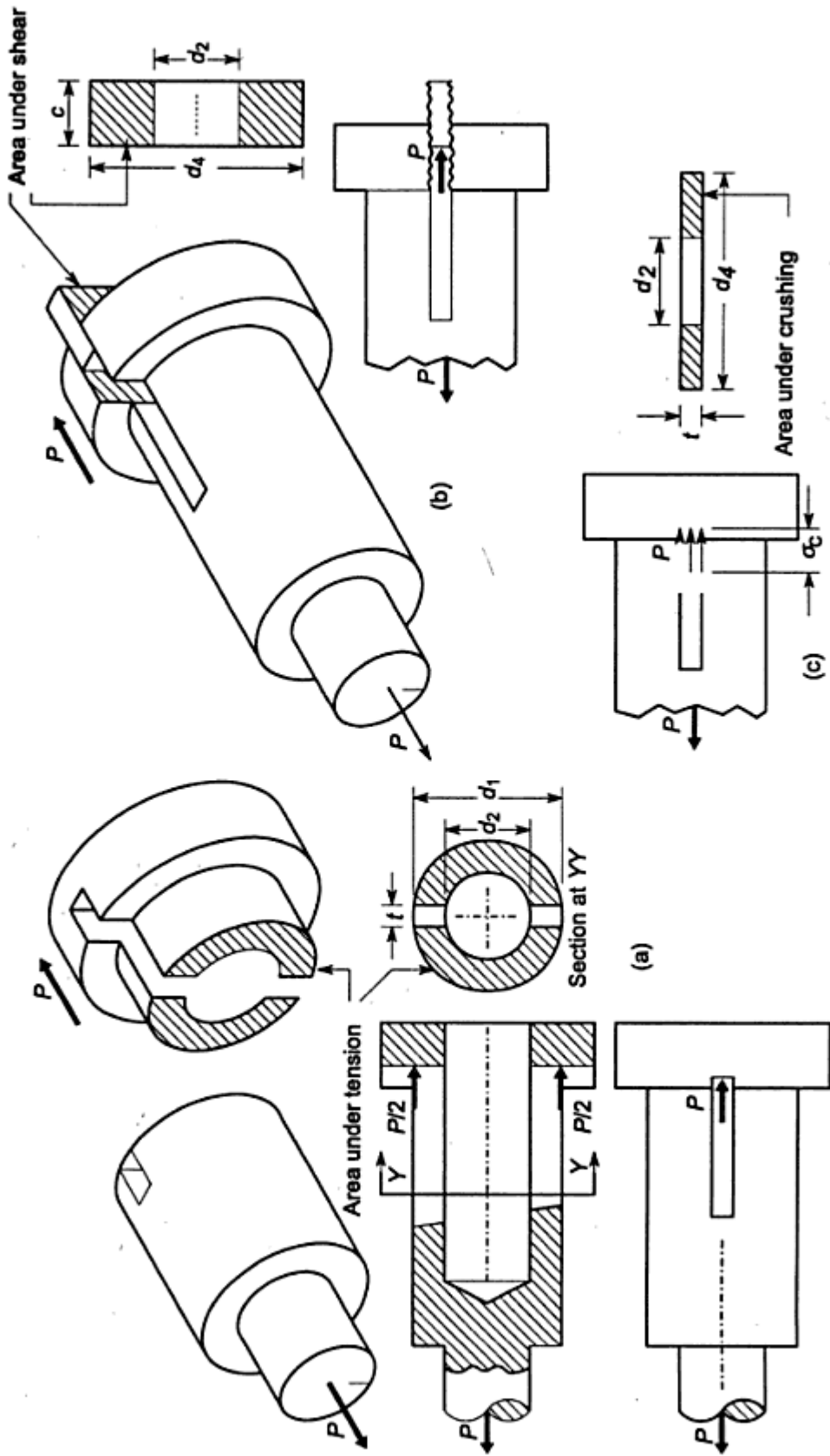
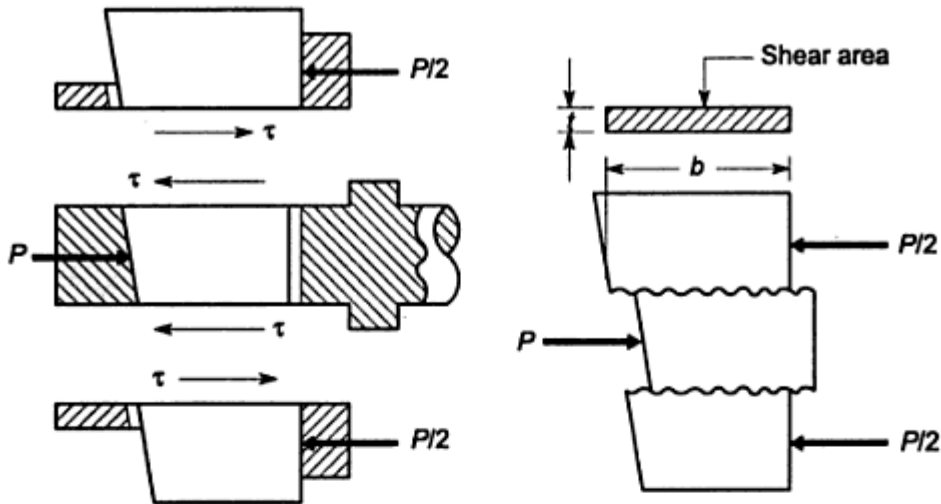

Fig. 3.18 Stresses in Socket end (a) Tensile Stress (b) Shear Stress (c) Compressive Stress



**Fig. 3.19** Shear Failure of Cotter

### 5. Shear Failure of Spigot End

Spigot end is subjected to double shear as shown in Fig. 3.17(b). The area of each of the two planes that resist shear failure is  $(ad_2)$ . Therefore, shear stress in spigot end is given by

$$\tau = \frac{P}{2(ad_2)}$$

or

$$P = 2 a d_2 \tau \quad (3.25-f)$$

where  $\tau$  is permissible shear stress for spigot. From Eq. (3.25-f), the dimension 'a' can be determined.

### 6. Shear Failure of Socket End

Socket end is also subjected to double shear as shown in Fig. 3.18(b). The area of each of the two planes that resist shear failure is given by,

$$\text{area} = (d_4 - d_2) c$$

Therefore, shear stress in socket end is given by,

$$\tau = \frac{P}{2(d_4 - d_2)c}$$

or

$$P = 2 (d_4 - d_2) c \tau \quad (3.25-g)$$

From above equation, the dimension 'c' can be determined.

### 7. Crushing Failure of Spigot End

As shown in Fig. 3.17(c), the force  $P$  causes compressive stress on a narrow rectangular area of thickness  $t$  and width  $d_2$  perpendicular to the plane of paper. The compressive stress is given by,

$$\sigma_c = \frac{P}{t d_2} \quad (3.25-h)$$

### 8. Crushing Failure of Socket End

As shown in Fig. 3.18(c), the force  $P$  causes compressive stress on a narrow rectangular area of thickness  $t$ . The other dimension of rectangle, perpendicular to the plane of paper is  $(d_4 - d_2)$ . Therefore, compressive stress in socket end is given by,

$$\sigma_c = \frac{P}{(d_4 - d_2)t} \quad (3.25-i)$$

### 9. Bending Failure of Cotter

When the cotter is tight in socket and spigot, it is subjected to shear stresses. When it becomes loose, bending occurs. The forces acting on cotter are shown in Fig. 3.20(a). The force  $P$  between cotter and spigot end is assumed to be uniformly distributed over the length  $d_2$ . The force between socket end and cotter is assumed to be varying linearly from zero to maximum with triangular distribution. The cotter is treated as beam as shown in Fig. 3.20(b). For triangular distribution,

$$x = \frac{1}{3} y = \frac{1}{3} \left( \frac{d_4 - d_2}{2} \right) = \left( \frac{d_4 - d_2}{6} \right)$$

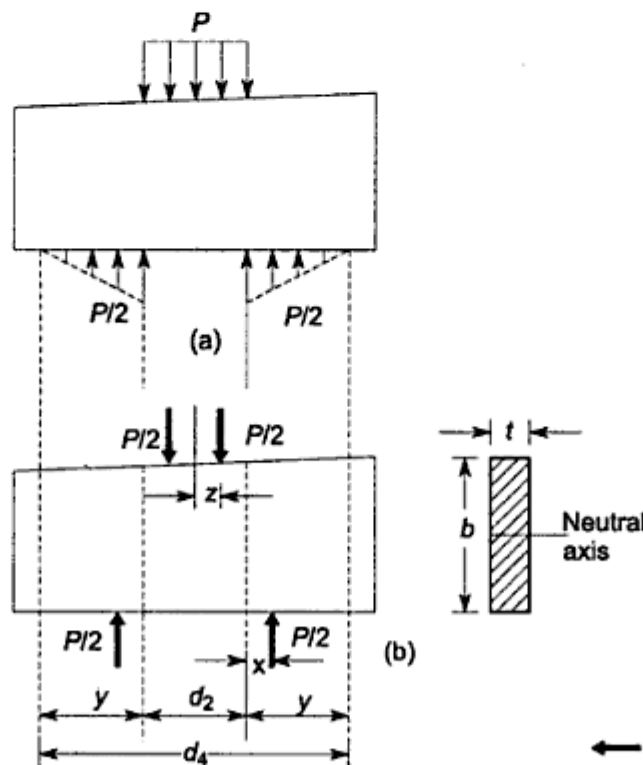

Fig. 3.20 Cotter Treated as Beam (a) Actual Distribution of Forces (b) Simplified Diagram of Forces



The bending moment is maximum at the centre. At the central section,

$$\begin{aligned} M_b &= \frac{P}{2} \left[ \frac{d_2}{2} + x \right] - \frac{P}{2} (z) \\ &= \frac{P}{2} \left[ \frac{d_2}{2} + \frac{d_4 - d_2}{6} \right] - \frac{P}{2} \left[ \frac{d_2}{4} \right] \\ &= \frac{P}{2} \left[ \frac{d_2}{4} + \frac{d_4 - d_2}{6} \right] \end{aligned}$$

Also,

$$I = \frac{tb^3}{12} \quad \text{and} \quad y = \frac{b}{2}$$

From Eq. (3.12),

$$\begin{aligned} \sigma_b &= \frac{M_b y}{I} \\ &= \frac{\frac{P}{2} \left[ \frac{d_2}{4} + \frac{d_4 - d_2}{6} \right] \frac{b}{2}}{\frac{tb^3}{12}} \end{aligned} \quad (3.25-j)$$

The applications of strength equations from (3.25-a) to (3.25-j) in finding out the dimensions of the cotter joint are illustrated in the next example and the design project. In some cases, the dimensions of cotter joint are calculated by using empirical relationships, without carrying out detail stress analysis. In such cases, following standard proportions can be used,

---

$d_1 = 1.75d$	$d_2 = 1.21d$
$d_3 = 1.5d$	$d_4 = 2.4d$
$a = c = 0.75d$	$b = 1.6d$
$t = 0.31d$	$t_1 = 0.45d$
clearance = 1.5 to 3mm	
taper for cotter = 1 in 32	

---

### 3.8 DESIGN PROCEDURE FOR COTTER JOINT

The basic procedure to calculate the dimensions of the cotter joint consists of following steps:

- (i) Calculate the diameter of each rod by Eq. (3.25-a),

$$d = \sqrt{\frac{4P}{\pi\sigma_t}}$$

- (ii) Calculate the thickness of the cotter by empirical relationship given in Eq. (3.25-c),

$$t = 0.31d$$

- (x) Calculate the thickness  $t_1$  of the spigot collar by following empirical relationship,

$$t_1 = 0.45 d$$

The taper of the cotter is 1 in 32.

The application of the above mentioned procedure is illustrated in design project.

### DESIGN PROJECT 1 Design of Cotter Joint

**Problem Specification** It is required to design a cotter joint to connect two steel rods of equal diameter. Each rod is subjected to an axial tensile force of 50kN. Design the joint and specify its main dimensions.

**Selection of Materials** The rods are subjected to tensile force and strength is the criterion for the selection of the rod material. The cotter is subjected to direct shear stress and bending stresses. Therefore, strength is also the criterion of material selection for the cotter. On the basis of strength, the material of two rods and cotter is selected as plain carbon steel of Grade 30C8 ( $S_{yt} = 400 \text{ N/mm}^2$ ). In stress analysis of the cotter joint, following factors are neglected:

- (i) Initial stresses due to tightening of the cotter, and
- (ii) Stress concentration due to slot in the socket and the spigot ends.

To account for these factors, a higher factor of safety is used in present design. The factor of safety for rods, spigot end and socket end is assumed as 6, while for cotter, it is taken as 4. There are two reasons for assuming lower factor of safety for the cotter. They are as follows,

- (i) There is no stress concentration in the cotter.
- (ii) The cost of cotter is small compared with the socket end or spigot end. If at all a failure is going to occur, it should occur in the cotter rather than in the spigot or socket end. This can be ensured by assuming higher factor of safety for the spigot and socket ends compared with the cotter.

It is assumed that the yield strength in compression is twice the yield strength in tension.

**Permissible Stresses** The permissible stresses for rods, spigot end and socket end are as follows,

$$\sigma_t = \frac{S_{yt}}{(fs)} = \frac{400}{6} = 66.67 \text{ N/mm}^2$$

$$\sigma_c = \frac{S_{yc}}{(fs)} = \frac{2S_{yt}}{(fs)} = \frac{2(400)}{6} = 133.33 \text{ N/mm}^2$$

$$\tau = \frac{S_{sy}}{(fs)} = \frac{0.5 S_{yt}}{(fs)} = \frac{0.5 (400)}{6} = 33.33 \text{ N/mm}^2$$

Step 6

$$a = c = 0.75 d = 0.75(32) = 24 \text{ mm}$$

Step 7

$$b = \frac{P}{2 \tau t} = \frac{50 \times 10^3}{2(50)(10)} = 50 \text{ mm} \quad (\text{a})$$

or

$$b = \sqrt{\frac{3P}{t \sigma_b} \left[ \frac{d_2}{4} + \frac{d_4 - d_2}{6} \right]}$$

$$= \sqrt{\frac{3(50 \times 10^3)}{(10)(100)} \left[ \frac{40}{4} + \frac{80 - 40}{6} \right]}$$

$$= 50 \text{ mm} \quad (\text{b})$$

From (a) and (b),

$$b = 50 \text{ mm}$$

Step 8

Stresses in spigot end :

$$\sigma_c = \frac{P}{t d_2} = \frac{50 \times 10^3}{(10)(40)} = 125 \text{ N/mm}^2$$

$$\tau = \frac{P}{2 a d_2} = \frac{50 \times 10^3}{2(24)(40)} = 26.04 \text{ N/mm}^2$$

$$\therefore \sigma_c < 133.33 \text{ N/mm}^2 \quad \text{and} \quad \tau < 33.33 \text{ N/mm}^2$$

Step 9

Stresses in socket end :

$$\sigma_c = \frac{P}{(d_4 - d_2)t} = \frac{50 \times 10^3}{(80 - 40)(10)} = 125 \text{ N/mm}^2$$

$$\tau = \frac{P}{2(d_4 - d_2)c} = \frac{50 \times 10^3}{2(80 - 40)(24)} = 26.04 \text{ N/mm}^2$$

$$\therefore \sigma_c < 133.33 \text{ N/mm}^2 \quad \text{and} \quad \tau < 33.33 \text{ N/mm}^2$$

The stresses induced in the spigot and the socket ends are within limits.

Step 10

$$t_1 = 0.45 d = 0.45(32) = 14.4 \text{ or } 15 \text{ mm}$$

The taper for the cotter is 1 in 32.

The dimensions of various components of cotter joint are shown in Fig. 3.21.

### Example 3.9

Two rods are connected by means of a cotter joint. The inside diameter of the socket and outside diameter of the socket collar are 50 and 100 mm respectively. The rods are subjected to a tensile force of 50 kN. The cotter is made of steel 30C8

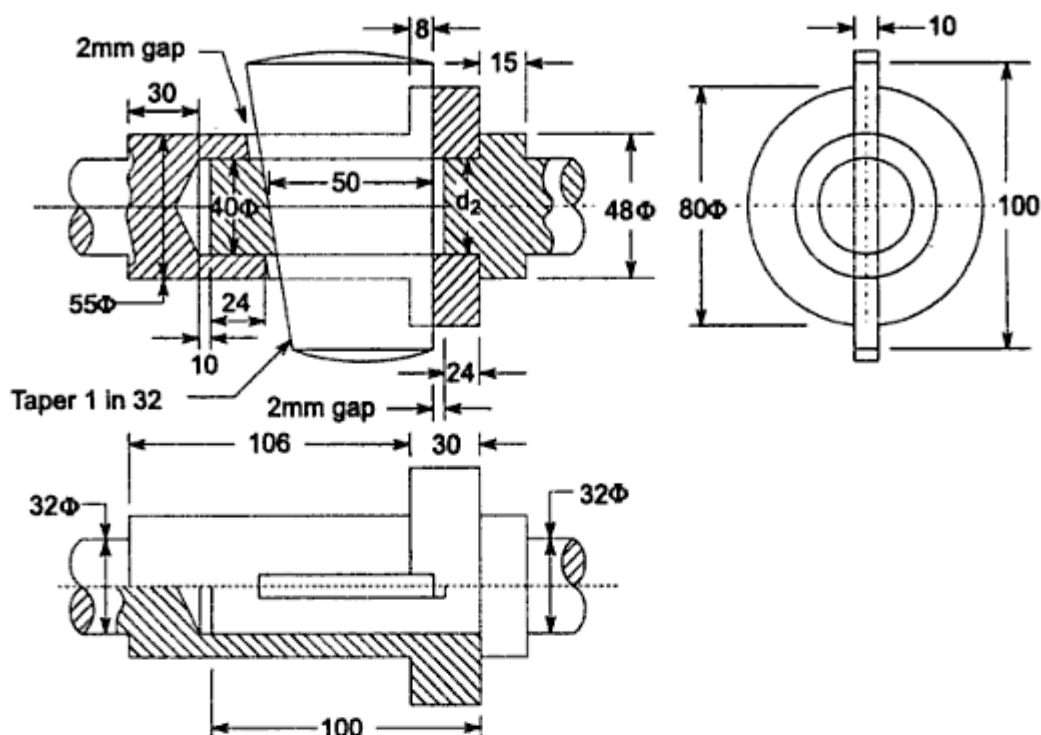

Fig. 3.21 Dimensions of Cotter Joint

( $S_{yt} = 400 \text{ N/mm}^2$ ) and the factor of safety is 4. The width of the cotter is five times of thickness. Calculate:

- Width and thickness of the cotter on the basis of shear failure, and
- Width and thickness of the cotter on the basis of bending failure.

**Solution** Permissible stresses:

$$\sigma_t = \frac{S_{yt}}{(fs)} = \frac{400}{4} = 100 \text{ N/mm}^2$$

$$\tau = \frac{S_{ys}}{(fs)} = \frac{0.5 S_{yt}}{(fs)} = \frac{0.5(400)}{4} = 50 \text{ N/mm}^2$$

Also,

$$b = 5t$$

From Eq. (3.25-e),

$$P = 2 b t \tau$$

$$50 \times 10^3 = 2 (5t) t (50)$$

$$\therefore t = 10 \text{ mm}$$

$$b = 5t = 50 \text{ mm}$$

(i)

From Eq. (3.25-j),

$$\sigma_b = \frac{P \left[ \frac{d_2}{4} + \frac{d_4 - d_2}{6} \right] b}{\frac{t b^3}{12}}$$

$$100 = \frac{\frac{50 \times 10^3}{2} \left[ \frac{50}{4} + \frac{(100 - 50)}{6} \right] (5t)}{t(5t)^3}$$

$$12$$

$$\therefore t = 10.77 \text{ or } 12\text{mm}$$

$$b = 5t = 60\text{mm} \quad (\text{ii})$$

### Example 3.10

Two rods, made of plain carbon steel 40C8 ( $S_{yt} = 380 \text{ N/mm}^2$ ), are to be connected by means of a cotter joint. The diameter of each rod is 50 mm and the cotter is made from a steel plate of 15 mm thickness. Calculate the dimensions of the socket end making following assumptions :

- (i) The yield strength in compression is twice of the tensile yield strength; and
- (ii) The yield strength in shear is 50% of the tensile yield strength.

The factor of safety is 6.

**Solution** Permissible stresses:

$$\sigma_t = \frac{S_{yt}}{(fs)} = \frac{380}{6} = 63.33 \text{ N/mm}^2$$

$$\sigma_c = \frac{S_{yc}}{(fs)} = \frac{2S_{yt}}{(fs)} = \frac{2(380)}{6} = 126.67 \text{ N/mm}^2$$

$$\tau = \frac{S_{sy}}{(fs)} = \frac{0.5S_{yt}}{(fs)} = \frac{0.5(380)}{6} = 31.67 \text{ N/mm}^2$$

Load carried by rods:

$$P = \frac{\pi}{4} d^2 \sigma_t$$

$$= \frac{\pi}{4} (50)^2 (63.33)$$

$$= 124\,348.16 \text{ N}$$

Inside diameter of socket ( $d_2$ ):

From Eq. (3.25-b),

$$P = \left[ \frac{\pi}{4} d_2^2 - d_2 t \right] \sigma_t$$

$$124\,348.16 = \left[ \frac{\pi}{4} d_2^2 - d_2 (15) \right] (63.33)$$

or,

$$d_2^2 - 19.1 d_2 - 2500 = 0$$

Solving the above quadratic equation,

$$d_2 = \frac{19.1 \pm \sqrt{19.1^2 - 4(-2500)}}{2}$$

$$\therefore d_2 = 60.45 \text{ or } 65 \text{ mm} \quad (\text{i})$$

Outside diameter of socket ( $d_1$ ):

From Eq. (3.25-d),

$$P = \left[ \frac{\pi}{4}(d_1^2 - d_2^2) - (d_1 - d_2)t \right] \sigma_1$$

$$124\,348.16 = \left[ \frac{\pi}{4}(d_1^2 - 65^2) - (d_1 - 65)(15) \right] (63.33)$$

or,  $d_1^2 - 19.1 d_1 - 5483.59 = 0$

Solving the above quadratic equation,

$$d_1 = \frac{19.1 \pm \sqrt{19.1^2 - 4(-5483.59)}}{2}$$

$$\therefore d_1 = 84.21 \text{ or } 85 \text{ mm} \quad (\text{ii})$$

Diameter of socket collar ( $d_4$ ):

From Eq. (3.25-i),

$$\sigma_c = \frac{P}{(d_4 - d_2)t}$$

$$126.67 = \frac{124\,348.16}{(d_4 - 65)(15)}$$

$$\therefore d_4 = 130.44 \text{ or } 135 \text{ mm} \quad (\text{iii})$$

Dimensions  $a$  and  $c$ :

From Eq. (3.25-f),

$$a = \frac{P}{2d_2 \tau} = \frac{124\,348.16}{2(65)(31.67)} = 30.20 \text{ or } 35 \text{ mm} \quad (\text{iv})$$

From Eq. (3.25-g),

$$c = \frac{P}{2(d_4 - d_2)\tau} = \frac{124\,348.16}{2(135 - 65)(31.67)} = 28.04 \text{ or } 30 \text{ mm} \quad (\text{v})$$

### 3.9 COTTER FOUNDATION BOLTS

Cotter foundation bolts are used on the shop-floor to hold down the base plates of the machine tools to the concrete foundation. The construction of this type of bolt is shown in Fig. 3.22. The bolt is inserted in the hole from the top and the cotter is driven from the side. The assembly of base plate, bolt, cotter and steel plate is tightened by screwing down the nut. The base plate under the nut and the steel plate at the bottom are provided to distribute the tightening force over large surface area of the concrete. Following notations are used in analysis of the cotter foundation bolts,

$d$  = diameter of bolt (mm).

$d_1$  = enlarged diameter of bolt (mm).

### 3. Shear Failure of Cotter

The cotter is subjected to double shear. The shear stress in the cotter is given by,

$$\tau = \frac{P}{2bt} \quad (3.26-c)$$

The thickness of the cotter is usually taken by following empirical relationship,

$$t = \frac{d_1}{4} \quad (3.26-d)$$

### 4. Compression Failure of Cotter

The compressive stress between the cotter and the enlarged end of the bolt is given by,

$$\sigma_c = \frac{P}{td_1} \quad (3.26-e)$$

### Example 3.11

A foundation bolt with circular end is secured by means of a cotter. The cotter and the bolt are made of plain carbon steel 40C8 ( $S_{yt} = 380 \text{ N/mm}^2$ ) and the factor of safety is 5. The yield strength in compression can be assumed to be twice of the tensile yield strength. The bolt is subjected to a maximum pull of 50kN. Calculate:

- (i) The diameter of the bolt;
- (ii) The diameter of the enlarged end of the bolt,
- (iii) The thickness and the width of the cotter; and
- (iv) The compressive stress between the cotter and the bolt.

**Solution** Permissible stresses

$$\sigma_t = \frac{S_{yt}}{(fs)} = \frac{380}{5} = 76 \text{ N/mm}^2$$

$$\sigma_c = \frac{S_{yc}}{(fs)} = \frac{2S_{yt}}{(fs)} = \frac{2(380)}{5} = 152 \text{ N/mm}^2$$

$$\tau = \frac{S_{sy}}{(fs)} = \frac{0.5S_{yt}}{(fs)} = \frac{0.5(380)}{5} = 38 \text{ N/mm}^2$$

From Eq. (3.26-a),

$$d = \sqrt{\frac{4P}{\pi\sigma_t}} = \sqrt{\frac{4(50 \times 10^3)}{\pi(76)}} = 28.94 \text{ or } 30 \text{ mm} \quad (i)$$

From Eq. (3.26-b),

$$\sigma_t = \frac{P}{\left[ \frac{\pi}{4} d_1^2 - d_1 t \right]}$$

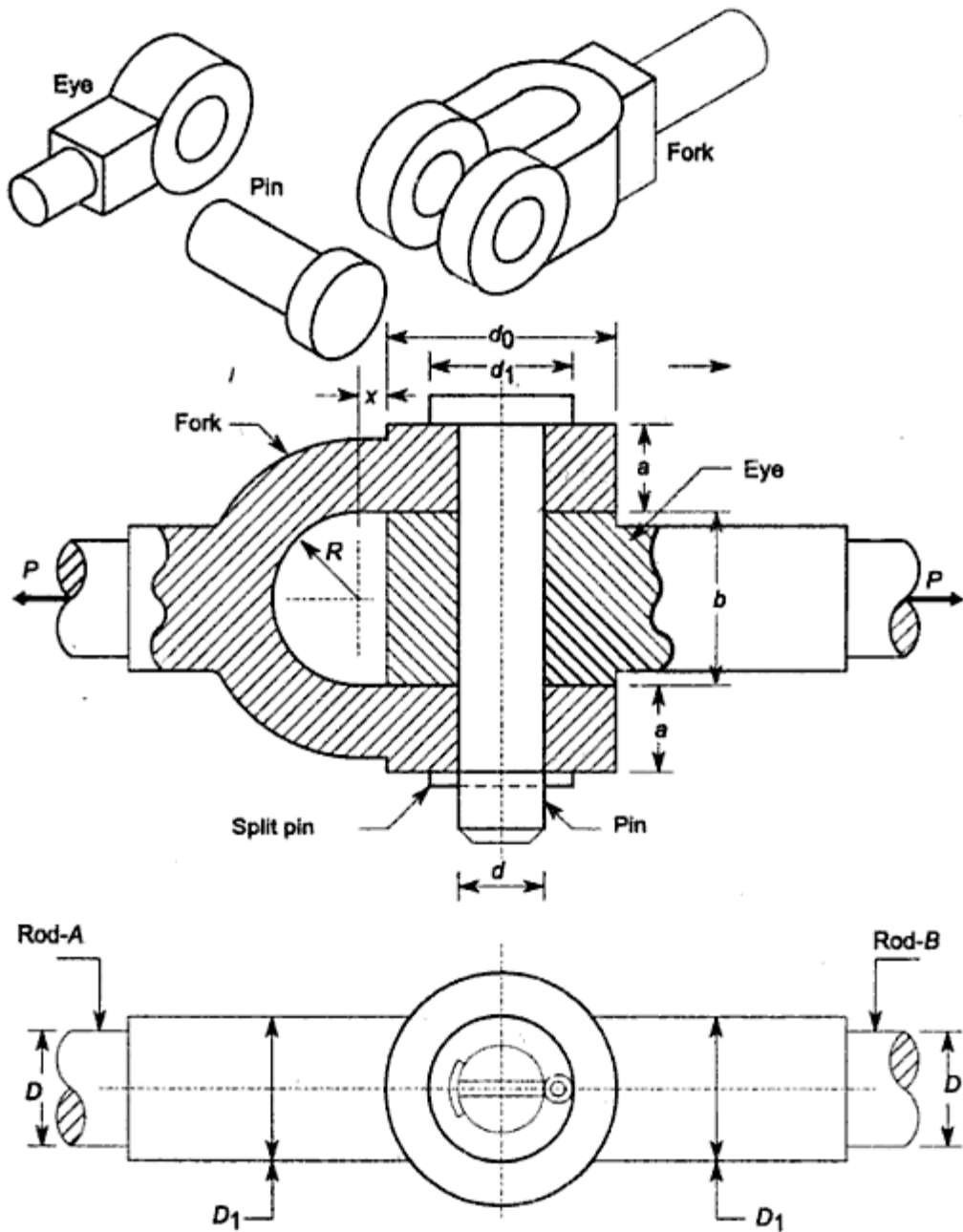

Fig. 3.23 Knuckle Joint

a pin passes through both the fork and the eye. This pin is secured in its place by means of a split-pin. Due to this type of construction, knuckle joint is sometimes called 'forked-pin' joint. In rare applications, a knuckle joint is used to connect three rods—two with forks and third with eye. The knuckle joint offers following advantages:

- (i) The joint is simple to design and manufacture,
- (ii) There are few parts in knuckle joint, which reduces cost and improves reliability,
- (iii) The assembly or dismantling of the parts of knuckle joint is quick and simple. The assembly consists of inserting the eye of one rod inside the



fork of other rod and putting the pin in their common hole and finally putting the split-pin to hold the pin. Dismantling consists of removing the split pin and taking the pin out of the eye and the fork.

In Fig. 3.23, following notations are used

$D$  = diameter of each rod (mm).

$D_1$  = enlarged diameter of each rod (mm).

$d$  = diameter of knuckle pin (mm).

$d_o$  = outside diameter of eye or fork (mm).

$a$  = thickness of each eye of fork (mm).

$b$  = thickness of eye end of rod-B (mm).

$d_1$  = diameter of pin head (mm).

$x$  = distance of the centre of fork radius  $R$  from the eye (mm).

For the purpose of stress analysis of knuckle joint following assumptions are made,

- (i) The rods are subjected to axial tensile force,
- (ii) The effect of stress concentration due to holes is neglected, and
- (ii) The force is uniformly distributed in various parts.

Free body diagram of forces acting on three components of the knuckle joint viz. fork, pin and eye is shown in Fig. 3.24. This diagram is constructed by using the principle that actions and reactions are equal and opposite. The forces are determined in the following way,

- (i) Consider rod-A with fork end. The rod is subjected to horizontal force  $P$  to the left. The sum of all horizontal forces acting on rod-A must be equal to zero. Therefore, there should be a force  $P$  to the right acting on the fork end. This is shown by two parts, each equal to  $(P/2)$  on the fork end.
- (ii) Consider rod-B with eye end. The rod is subjected to horizontal force  $P$  to the right side. The sum of all horizontal forces acting on rod-B must be equal to zero. Therefore, there should be a force  $P$  to the left acting on the eye end.
- (iii) The forces shown on the pin are equal and opposite reactions of forces acting on the fork end of rod-A and the eye end of rod-B.

In order to find out various dimensions of the parts of knuckle joint, failures in different parts and at different cross-sections are considered. For each type of failure, one strength equation is written. Finally, these strength equations are used to find out various dimensions of the knuckle joint.

### 1. Tensile Failure of Rods

Each rod is subjected to tensile force  $P$ . The tensile stress in the rod is given by,

$$\sigma_t = \frac{P}{\left(\frac{\pi}{4} D^2\right)}$$

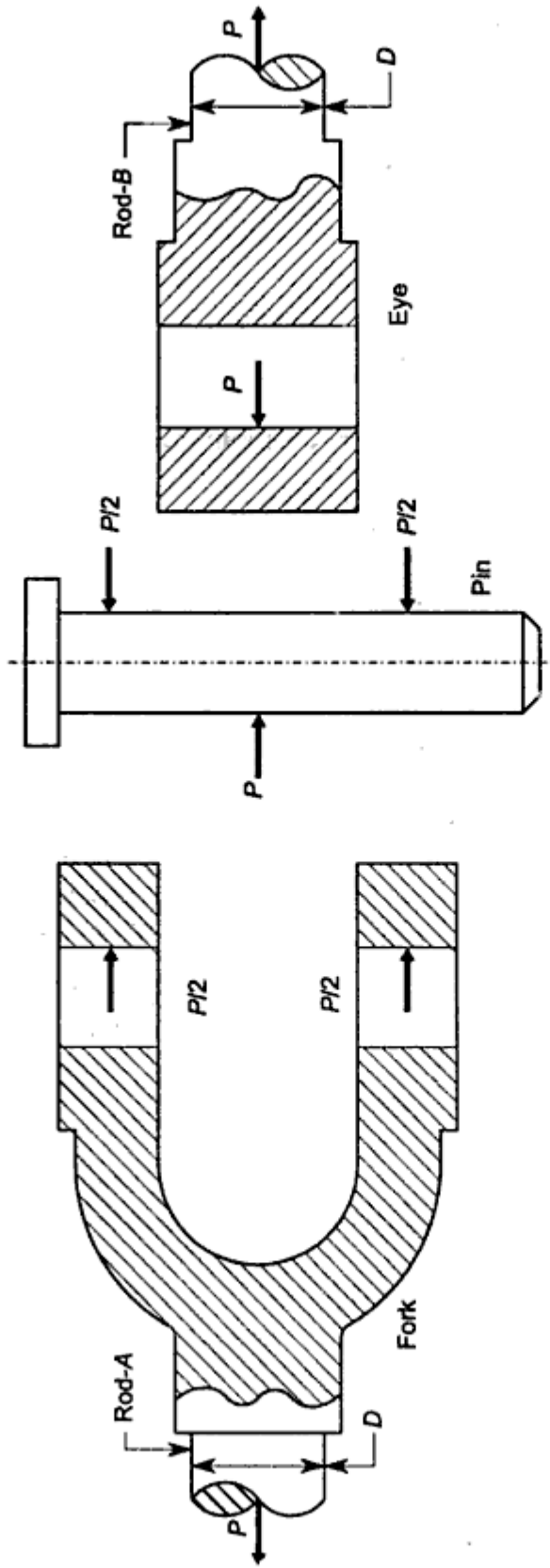

Fig. 3.24 Free Body Diagram of Forces

$$\text{or, } D = \sqrt{\frac{4P}{\pi\sigma_t}} \quad (3.27-a)$$

where  $\sigma_t$  is permissible tensile stress for the rods. The enlarged diameter  $D_1$  of the rod near the joint is determined by following empirical relationship,

$$D_1 = 1.1 D \quad (3.27-b)$$

## 2. Shear Failure of Pin

The pin is subjected to double shear as shown in Fig. 3.25. The area of each of the two planes that resist shear failure is  $\left(\frac{\pi}{4}d^2\right)$ . Therefore, shear stress in the pin is given by,

$$\tau = \frac{P}{2\left(\frac{\pi}{4}d^2\right)}$$

$$\text{or, } d = \sqrt{\frac{2P}{\pi\tau}} \quad (3.27-c)$$

where  $\tau$  is permissible shear stress for the pin. The standard proportion for the diameter of the pin is as follows,

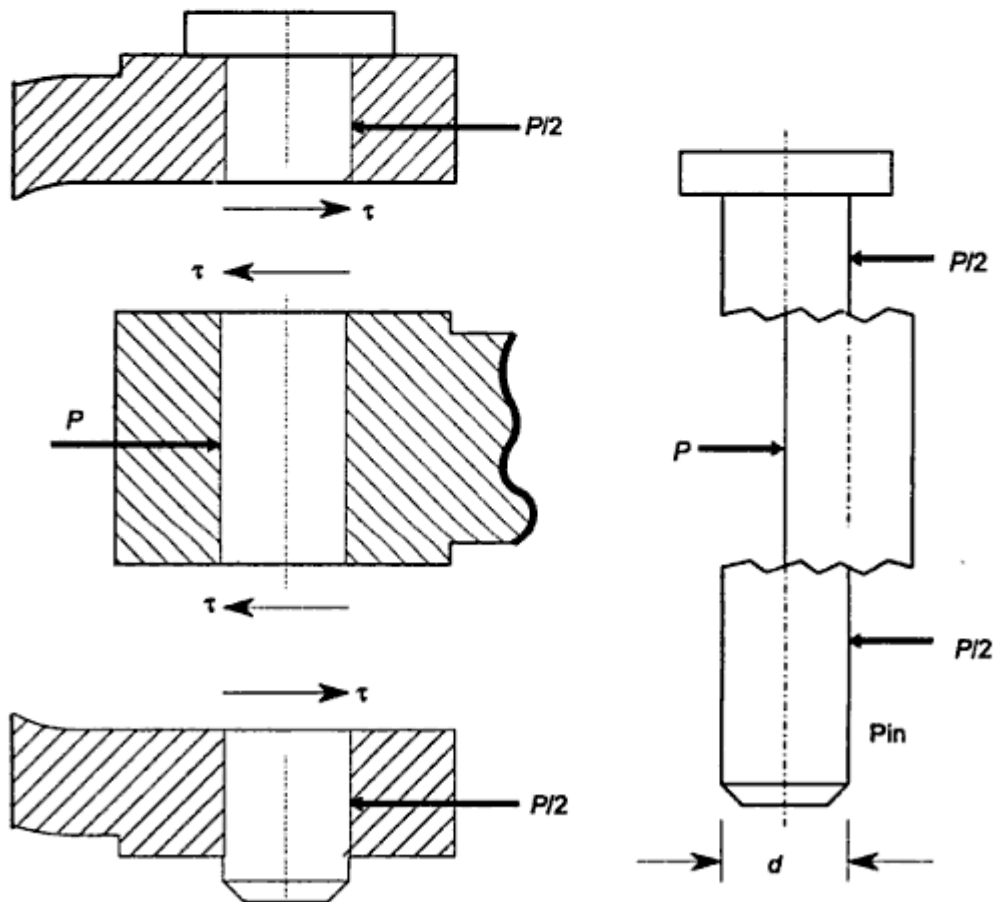

Fig. 3.25 Shear Failure of Pin

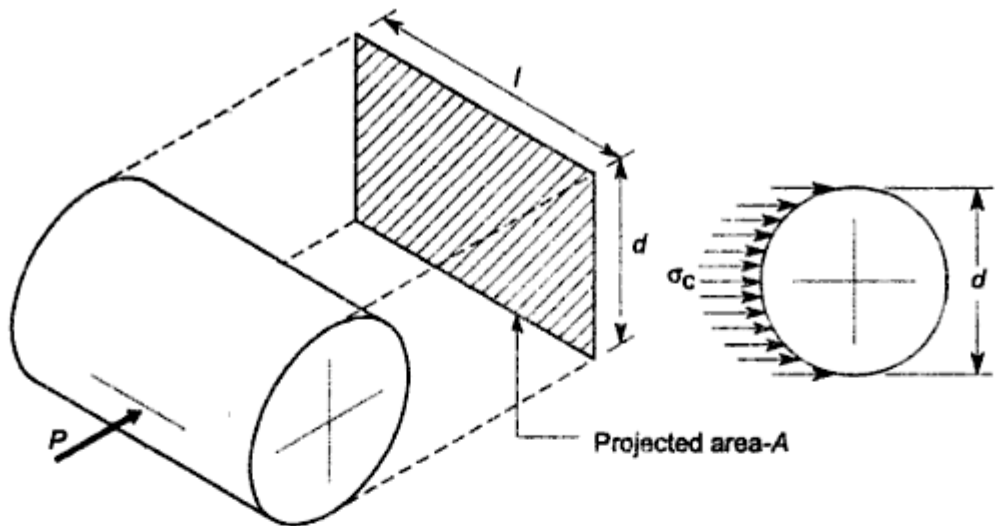

Fig. 3.26 Projected Area of Cylindrical Surface

From Eq. (3.12),

$$\sigma_b = \frac{M_b y}{I} = \frac{\frac{P}{2} \left[ \frac{b}{4} + \frac{a}{3} \right] \frac{d}{2}}{\frac{\pi d^4}{64}}$$

or,

$$\sigma_b = \frac{32}{\pi d^3} \times \frac{P}{2} \left[ \frac{b}{4} + \frac{a}{3} \right] \quad (3.27-g)$$

## 6. Tensile Failure of Eye

Section *XX* shown in Fig. 3.28(a) is the weakest section of the eye. The area of this section is given by,

$$\text{area} = b (d_o - d)$$

The tensile stress at section *XX* is given by,

$$\sigma_t = \frac{P}{\text{area}}$$

or

$$\sigma_t = \frac{P}{b(d_o - d)} \quad (3.27-h)$$

## 7. Shear Failure of Eye

The eye is subjected to double shear as shown in Fig. 3.28(b). The area of each of the two planes resisting the shear failure is  $[b (d_o - d)/2]$  approximately. Therefore shear stress is given by,

**8. Tensile Failure of Fork**

Fork is a double eye and as such, Fig. 3.28 is applicable to fork except dimension 'b' which can be modified as '2a' in case of fork. The area of weakest section resisting tensile failure is given by,

$$\text{area} = 2a(d_0 - d)$$

Tensile stress in the fork is given by,

$$\sigma_t = \frac{P}{2a(d_0 - d)} \quad (3.27-k)$$

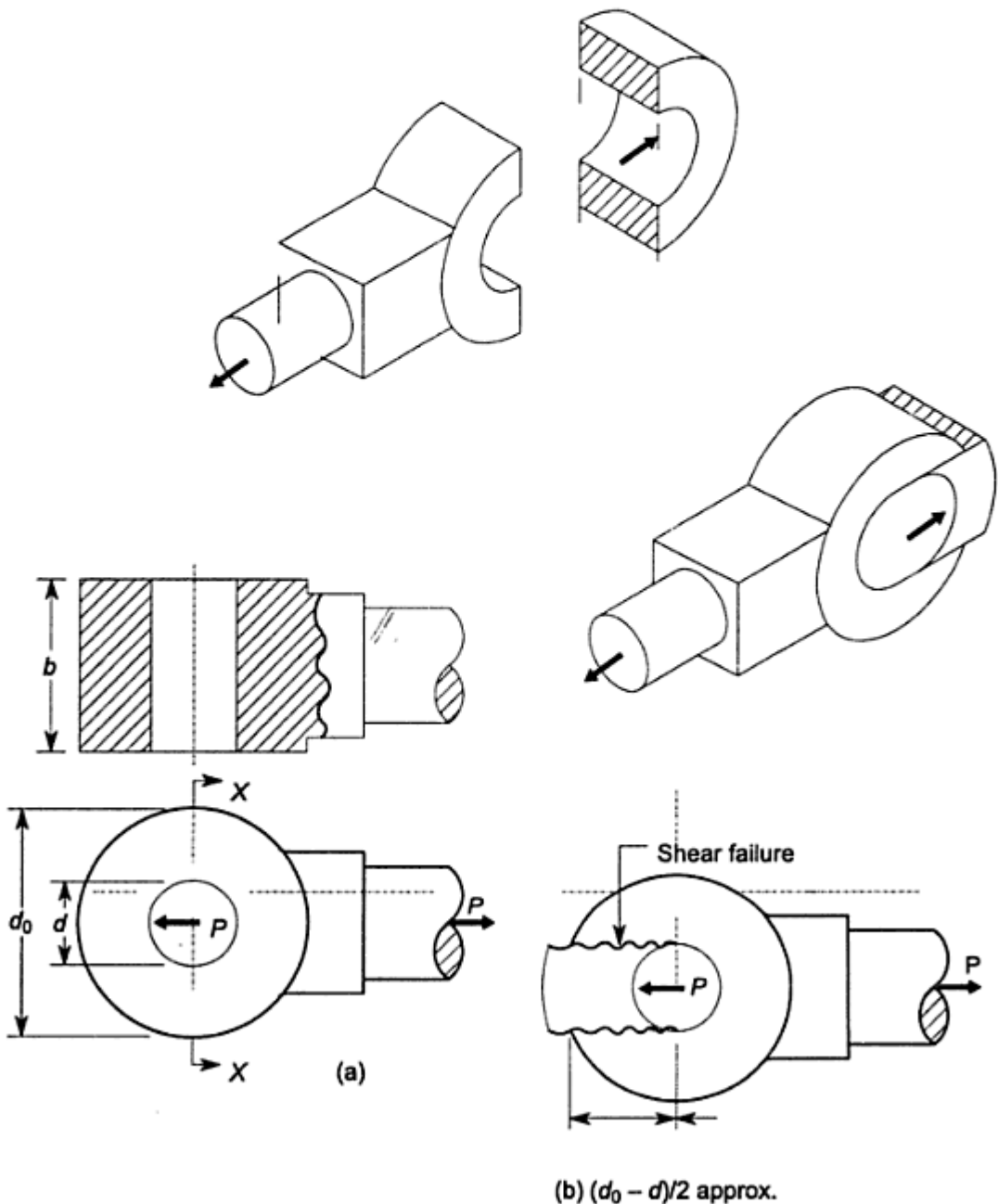

**Fig. 3.28** (a) Tensile Failure of Eye (b) Shear Failure of Eye

### 9. Shear Failure of Fork

Each of the two parts of the fork is subjected to double shear. Modifying Eq. (3.27-i),

$$\tau = \frac{P}{2a(d_o - d)} \quad (3.27-l)$$

Standard proportions for the dimensions  $a$  and  $b$  are as follows,

$$a = 0.75 D \quad (3.27-m)$$

$$b = 1.25 D \quad (3.27-n)$$

The diameter of the pin head is taken as,

$$d_1 = 1.5 d \quad (3.27-o)$$

The gap 'x' shown in Fig. 3.23 is usually taken as 10mm.

$$\therefore x = 10 \text{ mm} \quad (3.27-p)$$

The applications of strength equations from (3.27-a) to (3.27-l) in finding out the dimensions of the knuckle joint are illustrated in the next example and the design project. The eye and the fork are usually made by forging process, while the pin is machined from rolled steel bars.

### 3.11 DESIGN PROCEDURE FOR KNUCKLE JOINT

The basic procedure to determine the dimensions of the knuckle joint consists of following steps:

- (i) Calculate the diameter of each rod by Eq. (3.27-a)

$$D = \sqrt{\frac{4P}{\pi \sigma_t}}$$

- (ii) Calculate the enlarged diameter of each rod by empirical relationship using Eq. (3.27-b).

$$D_1 = 1.1 D$$

- (iii) Calculate the dimensions  $a$  and  $b$  by empirical relationship using Eqs. (3.27-m) and (3.27-n).

$$a = 0.75 D$$

$$b = 1.25 D$$

- (iv) Calculate the diameters of the pin by shear consideration using Eq. (3.27-c) and bending consideration using Eq. (3.27-g) and select the diameter, whichever is maximum.

$$d = \sqrt{\frac{2P}{\pi \tau}}$$

or,

$$d = \sqrt[3]{\frac{32}{\pi \sigma_b} \times \frac{P}{2} \left[ \frac{b}{4} + \frac{a}{3} \right]}$$

(which ever is maximum)

- (v) Calculate the dimensions  $d_0$  and  $d_1$  by empirical relationships using Eqs. (3.27-j) and (3.27-o) respectively.

$$d_0 = 2d$$

$$d_1 = 1.5d$$

- (vi) Check the tensile, crushing and shear stresses in the eye by Eqs. (3.27-h), (3.27-e) and (3.27-i) respectively.

$$\sigma_t = \frac{P}{b(d_0 - d)}$$

$$\sigma_c = \frac{P}{bd}$$

$$\tau = \frac{P}{b(d_0 - d)}$$

- (vii) Check the tensile, crushing and shear stresses in the fork by Eqs (3.27-k), (3.27-f) and (3.27-l) respectively.

$$\sigma_t = \frac{P}{2a(d_0 - d)}$$

$$\sigma_c = \frac{P}{2ad}$$

$$\tau = \frac{P}{2a(d_0 - d)}$$

The application of the above mentioned procedure is illustrated in design project.

## DESIGN PROJECT 2 Design of Knuckle Joint

**Problem Specification** It is required to design a knuckle joint to connect two circular rods subjected to an axial tensile force of 50 kN. The rods are co-axial and a small amount of angular movement between their axes is permissible. Design the joint and specify the dimensions of its components.

**Selection of Materials** The rods are subjected to tensile force. Therefore, yield strength is the criterion for the selection of material for the rods. The pin is subjected to shear stress and bending stresses. Therefore, strength is also the

criterion for material selection of the pin. On strength basis, the material for two rods and pin is selected as plain carbon steel of Grade 30C8 ( $S_{yt} = 400 \text{ N/mm}^2$ ). In stress analysis of knuckle joint, the effect of stress concentration is neglected. To account for this effect, a higher factor of safety of 5 is assumed in present design. It is further assumed that the yield strength in compression is equal to yield strength in tension. In practice, the compressive strength of steel is much higher than its tensile strength.

#### Permissible Stresses

$$\sigma_t = \frac{S_{yt}}{(fs)} = \frac{400}{5} = 80 \text{ N/mm}^2$$

$$\sigma_c = \frac{S_{yc}}{(fs)} = \frac{S_{yt}}{(fs)} = \frac{400}{5} = 80 \text{ N/mm}^2$$

$$\tau = \frac{S_{sy}}{(fs)} = \frac{0.5S_{yt}}{(fs)} = \frac{0.5(400)}{5} = 40 \text{ N/mm}^2$$

**Calculation of Dimensions** The dimensions of the knuckle joint are calculated by the procedure outlined in Article 3.11.

Step 1

$$D = \sqrt{\frac{4P}{\pi\sigma_t}}$$

$$= \sqrt{\frac{4(50 \times 10^3)}{\pi(80)}} = 28.21 \text{ or } 30 \text{ mm}$$

Step 2

$$D_1 = 1.1 D = 1.1(30) = 33 \text{ or } 35 \text{ mm}$$

Step 3

$$a = 0.75 D = 0.75(30) = 22.5 \text{ or } 25 \text{ mm}$$

$$b = 1.25 D = 1.25(30) = 37.5 \text{ or } 40 \text{ mm}$$

Step 4

$$d = \sqrt{\frac{2P}{\pi\tau}} = \sqrt{\frac{2(50 \times 10^3)}{\pi(40)}} = 28.21 \text{ or } 30 \text{ mm}$$

Also,

$$d = \sqrt[3]{\frac{32}{\pi\sigma_b} \times \frac{P}{2} \left[ \frac{b}{4} + \frac{a}{3} \right]}$$

$$= \sqrt[3]{\frac{32}{\pi(80)} \times \frac{(50 \times 10^3)}{2} \left[ \frac{40}{4} + \frac{25}{3} \right]}$$



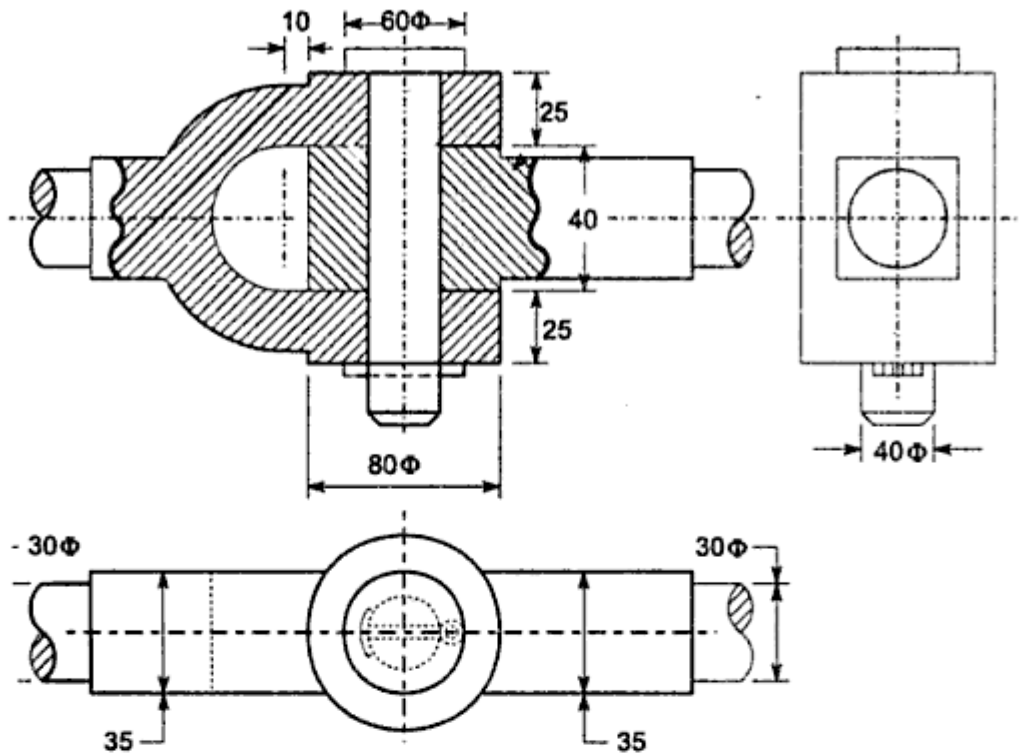

Fig. 3.29 Dimensions of Knuckle Joint

The diameter of the pin on the basis of shear strength, and  
The diameter of the pin on the basis of bending strength.

on Permissible stresses:

$$\sigma_t = \frac{S_{yt}}{(fs)} = \frac{400}{5} = 80 \text{ N/mm}^2$$

$$\tau = \frac{S_{sy}}{(fs)} = \frac{0.5 S_{yt}}{(fs)} = \frac{0.5(400)}{5} = 40 \text{ N/mm}^2$$

Eq. (3.27-c),

$$d = \sqrt{\frac{2P}{\pi\tau}}$$

$$d = \sqrt{\frac{2(30 \times 10^3)}{\pi(40)}} = 21.85 \text{ mm}$$

(i)

Eq. (3.27-g),

$$\sigma_b = \frac{32}{\pi d^3} \times \frac{P}{2} \left[ \frac{b}{4} + \frac{a}{3} \right]$$

$$80 = \frac{32}{\pi d^3} \times \frac{(30 \times 10^3)}{2} \left[ \frac{50}{4} + \frac{25}{3} \right]$$

$$d = 34.14 \text{ mm}$$

(ii)

$$= \frac{32}{\pi(63.33)} \times \frac{(25 \times 10^3)}{2} \left[ \frac{35}{4} + \frac{20}{3} \right]$$

$$\therefore d = 31.41 \text{ or } 35 \text{ mm} \quad (\text{ii})$$

Also,

$$d_0 = 2d = 2(35) = 70 \text{ mm}$$

Shear stress in pin:

From Eq. (3.27-c),

$$\tau = \frac{P}{2\left(\frac{\pi}{4}d^2\right)} = \frac{(25 \times 10^3)}{2\left(\frac{\pi}{4}(35)^2\right)} = 12.99 \text{ N/mm}^2 \quad (\text{iii})$$

$$\therefore \tau < 31.67 \text{ N/mm}^2$$

Compressive stress between the pin and eye end:

From Eq. (3.27-e),

$$\sigma_c = \frac{P}{bd} = \frac{(25 \times 10^3)}{35(35)} = 20.41 \text{ N/mm}^2 \quad (\text{iv})$$

$$\therefore \sigma_c < 126.67 \text{ N/mm}^2$$

Compressive stress between the pin and fork end:

From Eq. (3.27-f),

$$\sigma_c = \frac{P}{2ad} = \frac{(25 \times 10^3)}{2(20)(35)} = 17.86 \text{ N/mm}^2 \quad (\text{v})$$

$$\therefore \sigma_c < 126.67 \text{ N/mm}^2$$

Tensile stress in the eye end:

From Eq. (3.27-h),

$$\sigma_t = \frac{P}{b(d_0 - d)} = \frac{(25 \times 10^3)}{35(70 - 35)} = 20.41 \text{ N/mm}^2 \quad (\text{vi})$$

$$\therefore \sigma_t < 66.33 \text{ N/mm}^2$$

Shear stress in the eye end:

From Eq. (3.27-i),

$$\tau = \frac{P}{b(d_0 - d)} = \frac{(25 \times 10^3)}{35(70 - 35)} = 20.41 \text{ N/mm}^2 \quad (\text{vii})$$

$$\therefore \tau < 31.67 \text{ N/mm}^2$$

Tensile stress in the fork:

From Eq. (3.27-k),

$$\sigma_t = \frac{P}{2a(d_0 - d)} = \frac{(25 \times 10^3)}{2(20)(70 - 35)} = 17.86 \text{ N/mm}^2 \quad (\text{viii})$$

$$\therefore \sigma_t < 66.33 \text{ N/mm}^2$$

Shear stress in the fork:

From Eq. (3.27-1),

$$\tau = \frac{P}{2a(d_o - d)} = \frac{(25 \times 10^3)}{2(20)(70 - 35)} = 17.86 \text{ N/mm}^2 \quad (\text{ix})$$

$$\therefore \tau < 31.67 \text{ N/mm}^2$$

### 3.12 LEVERS

A lever is defined as a mechanical device in the form of a rigid bar pivoted about the fulcrum to multiply or transfer the force. The construction of a simple lever is shown in Fig. 3.30.  $F$  is the force produced by the lever and  $P$  is the effort required to produce that force. The force  $F$  is often called 'load'. The perpendicular distance of the line of action of any force from the fulcrum is called the arm of the lever. Therefore  $l_1$  and  $l_2$  are effort arm and load arm respectively. Taking moment of forces about the fulcrum,

$$F \times l_2 = P \times l_1$$

$$\text{or,} \quad \frac{F}{P} = \frac{l_1}{l_2} \quad (\text{a})$$

The ratio of load to effort i.e. ( $F/P$ ) is called the 'mechanical advantage' of lever. The ratio of the effort arm to the load arm i.e. ( $l_1/l_2$ ) is called the 'leverage'. Therefore, mechanical advantage is equal to the leverage. It is seen by Eq. (a), that a large force can be exerted by a small effort by increasing leverage, i.e. increasing  $l_1$  and reducing  $l_2$ . In many applications, it is not possible to increase effort arm  $l_1$  due to space restrictions. In such applications, compound levers are used to obtain more leverage.

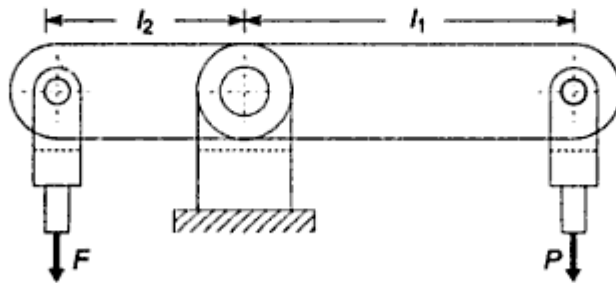

Fig. 3.30 Construction of Lever

There are three types of lever, based on the relative positions of the effort point, the load point and the fulcrum as illustrated in Fig. 3.31. They are as follows:

- (i) In the 'first' type of lever, the fulcrum is located between the load and the effort, as shown in Fig. 3.31 (a). In this case, the effort arm can be kept less than the load arm or equal to the load arm or more than the load arm. Accordingly, the mechanical advantages will vary in the following way,

When  $l_1 < l_2$ ,

mechanical advantage  $< 1$

When  $l_1 = l_2$ ,

mechanical advantage = 1

When  $l_1 > l_2$ ,

mechanical advantage  $> 1$

Usually, the effort arm is kept more than the load arm to get more mechanical advantage. This type of lever is used in applications like the rocker arm for the overhead valves of internal combustion engine, bell crank levers in railway signal mechanism and levers of hand pump.

- (ii) In the 'second' type of lever, the load is located between the fulcrum and the effort, as shown in Fig. 3.31 (b). In this case, the effort arm is always more than the load arm and the mechanical advantage is more than 1. This type of lever is used in lever loaded safety valve mounted on the boilers.
- (iii) In the 'third' type of lever, the effort is located between the load and the fulcrum, as shown in Fig. 3.31 (c). In this case, the load arm is always greater than the effort arm and the mechanical advantage is less than one. This type of lever is not recommended in engineering applications. A picking fork is an example of this type of lever.

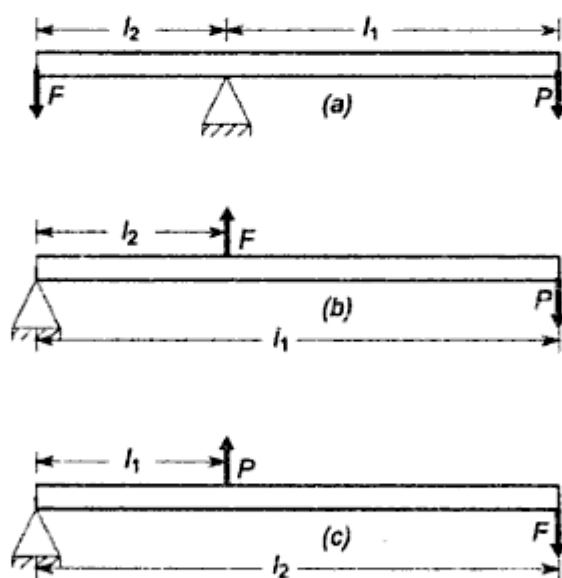

Fig. 3.31 Types of Lever

Levers have wide applications, ranging from simple nut cracker and paper punching machine to complex lever systems in scales and weighing machines.

### 3.13 DESIGN OF LEVERS

Lever design is easy compared with design of other machine elements. The length of the lever is decided on the basis of leverage required to exert a given load  $F$  by

means of an effort  $P$ . The cross-section of the lever is designed on the basis of bending stresses. The design of lever consists of following steps:-

### 1. Force Analysis

In any application, the load or the force  $F$ , to be exerted by the lever is given. The effort required to produce this force is calculated by taking moments about fulcrum. Therefore,

$$F \times l_2 = P \times l_1$$

or, 
$$P = F \left( \frac{l_2}{l_1} \right) \quad (3.1)$$

The free body diagram of forces acting on the 'first' type of the lever is shown in Fig. 3.32.  $R$  is the reaction at the fulcrum pin. Since the sum of vertical forces acting on the lever must be equal to zero,

$$R = F + P \quad (3.2)$$

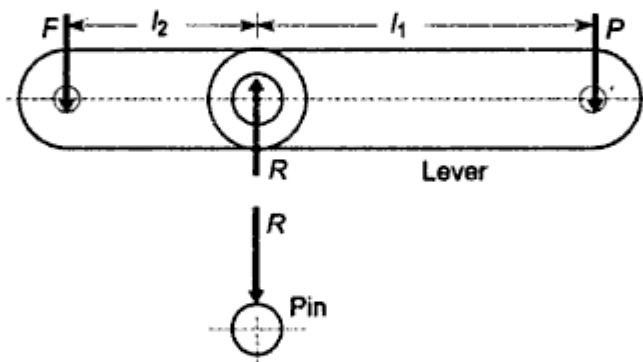

Fig. 3.32 Free Body Diagram of Forces Acting on First Type of Lever

The free body diagram of forces acting on the 'second' type of the lever is shown in Fig. 3.33. In this case, the load and the effort act in opposite directions. Considering equilibrium of forces in vertical direction,

$$F = R + P$$

or,

$$R = F - P \quad (3.30)$$

In above two cases, the forces are assumed to be parallel. Sometimes, the forces  $F$  and  $P$  act along lines that are inclined to one another as shown in Fig. 3.34. In such cases,  $l_1$  is perpendicular distance from the fulcrum to the line

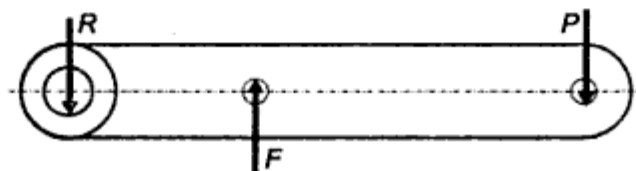

Fig. 3.33 Free Body Diagram of Forces Acting on Second Type of Lever

## 2. Design of Lever Arm

When the forces acting on the lever are determined, the next step in lever design is to find out the dimensions of the cross-section of the lever. The cross-section of the lever is subjected to bending moment. In case of two arm lever, as shown in Fig. 3.36, the bending moment is zero at the point of application of  $P$  or  $F$  and maximum at the boss of the lever. The cross-section at which the bending moment is maximum can be determined by constructing bending moment diagram. In Fig. 3.36 (a), the bending moment is maximum at section XX and it is given by,

$$M_b = P (l_1 - d_1)$$

The cross-section of the lever can be rectangular, elliptical or I-section. For rectangular cross-section,

$$I = \frac{bd^3}{12} \quad \text{and} \quad y = \frac{d}{2}$$

where  $b$  is the distance parallel to the neutral axis and  $d$  is the distance perpendicular to the neutral axis. The dimension  $d$  is usually taken as twice of  $b$ .  
or,

$$d = 2b$$

For elliptical cross-section,

$$I = \frac{\pi ba^3}{64} \quad \text{and} \quad y = \frac{a}{2}$$

where  $a$  and  $b$  are major and minor axes of the section. Usually, major axis is taken as twice of minor axis.

or,

$$a = 2b$$

Using the above mentioned proportions, the dimensions of the cross-section of the lever can be determined by,

$$\sigma_b = \frac{M_b y}{I}$$

Figure 3.36 (b) shows the variation of bending moment. It varies from a maximum value  $M_b$  at section XX to zero at the point of application of  $P$ . Therefore, the cross-section of the arm is usually tapered from the boss of the fulcrum to the end.

## 3. Design of Fulcrum Pin

The fulcrum pin is subjected to reaction  $R$  as shown in Fig. 3.37. The forces acting on the boss of lever and the pin are equal and opposite. The dimensions of the pin, viz. diameter  $d_1$  and length  $l_1$  in lever boss are determined by bearing consideration and then checked for shear consideration. There is relative motion between the pin and the lever and bearing pressure becomes the design criterion. The projected area of the pin is  $(d_1 \times l_1)$ . Therefore,

$$p = \frac{R}{(d_1 \times l_1)} \quad (\text{a})$$

There is similar example of the pin in knuckle joint illustrated in Fig. 3.26. For this pin, the compressive stress is given by,

$$\sigma_c = \frac{\text{force}}{\text{projected area}}$$

or,

$$p = \frac{P}{(d \times l)} \quad (\text{b})$$

Although the expressions (a) and (b) are same, there is basic difference between bearing pressure and crushing or compressive stress. The bearing pressure is considered, when there is relative motion between two surfaces such as surfaces of the pin and the bushing. On the other hand, crushing stress is considered when there is no relative motion between the surfaces under consideration. The bearing pressure is always low such as  $10 \text{ N/mm}^2$ , while the magnitude of compressive stress is high such as  $150 \text{ N/mm}^2$ . Rotating shaft in the bearing, fulcrum pin of oscillating lever, power screw rotating inside the nut are the examples where bearing pressure is design consideration. The contact area between cotter and spigot end and cotter and socket end [Eqs (3.25-h and i)], between knuckle pin and eye or knuckle pin and fork [Eqs (3.27-e and f)] are the examples, where crushing stress is the criterion of design.

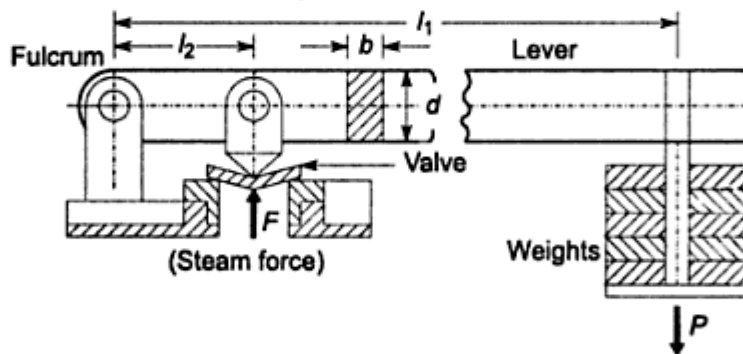

**Fig. 3.38** Lever Loaded Safety Valve

### Example 3.14

A lever loaded safety valve is mounted on the boiler to blow off at a pressure of  $1.5 \text{ MPa}$  gauge. The effective diameter of the opening of the valve is  $50 \text{ mm}$ . The distance between the fulcrum and the dead weights on the lever is  $1000 \text{ mm}$ . The distance between the fulcrum and the pin connecting the valve spindle to the lever is  $100 \text{ mm}$ . The lever and the pin are made of plain carbon steel 30C8 ( $S_{yt} = 400 \text{ N/mm}^2$ ) and the factor of safety is 5. The permissible bearing pressure at the pins in the lever is  $25 \text{ N/mm}^2$ . The lever has rectangular cross-section and the ratio of width to thickness is 3:1. Design suitable lever for the safety valve.

**Solution** The construction of the lever loaded safety valve is shown in Fig. 3.38. It is mounted on steam boilers to limit the maximum steam pressure. When the pressure inside the boiler exceeds this limiting value, the valve automatically opens due to excess of steam pressure and steam blows out through the valve. Consequently, the steam pressure inside the boiler is reduced. The valve is held tight on the valve seat against the upward steam force  $F$  by the dead weights  $P$  attached at the end of the lever. The distance  $l_1$  and the dead weights  $P$  are adjusted in such a way, that when the steam pressure inside the boiler reaches the limiting value, the moment  $(F \times l_2)$  overcomes the moment  $(P \times l_1)$ . As a result, the valve opens and steam blows out until the pressure falls to the required limiting value and then the valve is automatically closed.

The maximum steam load  $F$ , at which the valve blows off is given by,

$$F = \frac{\pi}{4} d^2 p = \frac{\pi}{4} (50)^2 (1.5) = 2945.24 \text{ N} \quad (\text{a})$$

Taking moment of forces  $F$  and  $P$  about the fulcrum,

$$F \times l_2 = P \times l_1$$

$$2945.24 \times 100 = P \times 1000$$

$$\therefore P = 294.52 \text{ N} \quad (\text{b})$$

The forces acting on the lever are shown in Fig. 3.39 (a). Considering equilibrium of vertical forces,

$$F = R + P$$

or,

$$R = F - P = 2945.24 - 294.52 = 2650.72 \text{ N} \quad (\text{c})$$

From (a), (b) and (c), the pin at the point of application of force  $F$  is subjected to maximum force and as such, it is to be designed from bearing consideration. Suppose,  $d_1$  and  $l_1$  are the diameter and the length of the pin at  $F$  and assuming,

$$l_1 = d_1$$

From Eq. (3.33),

$$F = p (d_1 \times l_1)$$

Substituting,

$$2945.24 = 25 (d_1 \times d_1)$$

$$\therefore d_1 = 10.85 \text{ or } 12 \text{ mm}$$

$$l_1 = d_1 = 12 \text{ mm} \quad (\text{i})$$

Permissible stresses for lever and pin:

$$\sigma_t = \frac{S_{yt}}{(fs)} = \frac{400}{5} = 80 \text{ N/mm}^2$$

$$\tau = \frac{S_{sy}}{(fs)} = \frac{0.5 S_{yt}}{(fs)} = \frac{0.5(400)}{5} = 40 \text{ N/mm}^2$$



The pin is subjected to double shear stress, which is given by,

$$\tau = \frac{F}{2 \left[ \frac{\pi}{4} d_1^2 \right]} = \frac{2945.24}{2 \left[ \frac{\pi}{4} (12)^2 \right]} = 13.02 \text{ N/mm}^2$$

$$\therefore \tau < 40 \text{ N/mm}^2$$

The force on the fulcrum pin ( $R$ ) is comparatively less than the force acting on the spindle pin ( $F$ ). Therefore, the dimensions  $d_1$  and  $l_1$  of the pin at the fulcrum will be slightly less. However, we will assume both pins of the same diameter and length to facilitate interchangeability of parts and variety reduction. A gun metal bush of 2 mm thickness is press fitted at both pin holes to reduce friction. Therefore, inside diameter of the boss will be  $(d_1 + 2 \times 2)$  or  $(12 + 2 \times 2)$  or 16 mm. The outside diameter of the boss is kept twice of the inside diameter i.e. 32 mm.

The bending moment diagram for the lever is shown in Fig. 3.39(b). The bending moment is maximum at the valve spindle axis. It is given by,

$$\begin{aligned} M_b &= P(1000 - 100) \\ &= 294.52(1000 - 100) \\ &= 265\,068 \text{ N-mm} \end{aligned}$$

For lever,

$$d = 3b$$

From Eq. (3.12),

$$\sigma_b = \frac{M_b y}{I} \quad 80 = \frac{(265\,068)(1.5b)}{\left[ \frac{1}{12} b (3b)^3 \right]}$$

$$\therefore b = 13.02 \text{ or } 15 \text{ mm}$$

$$d = 3b = 45 \text{ mm}$$

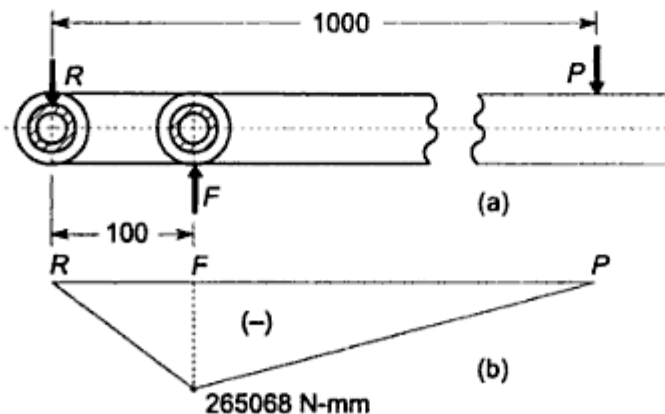

**Fig. 3.39** Force and Bending Moment Diagram of Lever

The lever becomes weak due to the pin hole at the valve spindle axis and it is necessary to check bending stresses at this critical section. The cross-section of the lever at the valve spindle axis is shown in Fig. 3.40. In this case, the length of the pin is increased from 12 mm to 20 mm to get practical proportions for the boss. For this cross-section,

$$M_b = 265\,068 \text{ N-mm}$$

$$y = 22.5 \text{ mm}$$

and,

$$I = \frac{1}{12} [15(45)^3 + 5(32)^3 - 20(16)^3]$$

$$= 120\,732.92 \text{ mm}^4$$

From Eq. (3.12),

$$\sigma_b = \frac{M_b y}{I} = \frac{(265\,068)(22.5)}{(120\,732.92)} = 49.40 \text{ N/mm}^2$$

Since,

$$\sigma_b < 80 \text{ N/mm}^2$$

the design is safe.

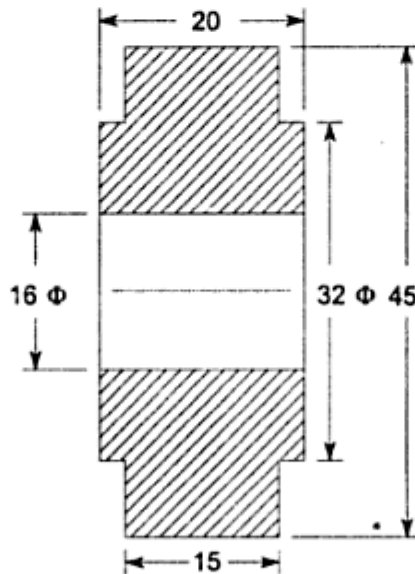

Fig. 3.40 Cross-section of Lever

### Example 3.15

A right angled bell-crank lever, used in a pump mechanism is shown in Fig. 3.41 (a). The lever and the pins are made of forged steel FeE 250 ( $S_{yt} = 250 \text{ N/mm}^2$ ) and the factor of safety is 4. The permissible bearing pressure at the pins is  $10 \text{ N/mm}^2$ . Determine the dimensions of the pins and the section of the lever near the fulcrum. The lever has rectangular cross-section and the ratio of width to thickness is 4:1

$$\therefore t < 31.25 \text{ N/mm}^2$$

The forces acting on remaining two pins are less than the force acting on the pin at the fulcrum. Therefore, dimensions  $d_1$  and  $l_1$  of remaining two pins will be less. However, we will assume all three pins of same diameter and length to facilitate interchangeability of parts and variety reduction. A gun metal bush of 2.5 mm thickness is press fitted at the pin holes to reduce friction and wear. Therefore, the inside diameter of the boss will be  $(d_1 + 2 \times 2.5)$  or  $(30 + 2 \times 2.5)$  or 35 mm. The outside diameter of the boss is kept twice of the inside diameter i.e. 70 mm.

The dimensions of the cross-section of the lever are determined by considering the bending stresses. It is assumed that the arm of bending moment on the lever extends upto the axis of the fulcrum. This assumption results in slightly higher bending moment and stronger cross-section. Therefore,

$$M_b = (5 \times 10^3) (500) = (25 \times 10^5) \text{ N-mm}$$

For the cross-section,

$$d = 4b$$

$$y = \frac{d}{2} = 2b$$

$$I = \frac{1}{12} b d^3 = \frac{1}{12} (b) (4b)^3 = \frac{16b^4}{3}$$

From Eq. (3.12),

$$\sigma_b = \frac{M_b y}{I}$$

Substituting values,

$$62.5 = \frac{(25 \times 10^5) (2b)}{\left(\frac{16b^4}{3}\right)}$$

$$\therefore b = 24.66 \text{ or } 25 \text{ mm}$$

and,

$$d = 4b = 100 \text{ mm}$$

The lever becomes weak due to pin hole at the fulcrum. Therefore, it is necessary to check actual bending stresses at this critical cross-section. The dimensions of this cross-section are shown in Fig. 3.41 (b). For this cross-section,

$$\begin{aligned} I &= \frac{1}{12} [25 (100)^3 + (15) (70)^3 - 40(35)^3] \\ &= 2\,369\,166.67 \text{ mm}^4 \\ y &= 50 \text{ mm} \end{aligned}$$

The shear stress in the pin is given by,

$$\tau = \frac{R}{2 \left[ \frac{\pi}{4} d_1^2 \right]} = \frac{5121.97}{2 \left[ \frac{\pi}{4} (20.24)^2 \right]} = 7.96 \text{ N/mm}^2 \quad (\text{ii})$$

The dimensions of the boss of the lever at the fulcrum are as follows,

$$\begin{aligned} \text{inner diameter} &= 21 \text{ mm} \\ \text{outer diameter} &= 42 \text{ mm} \\ \text{length} &= 26 \text{ mm} \end{aligned} \quad (\text{iii})$$

For the lever,

$$\begin{aligned} d &= 3b \\ M_b &= (5000 \times 100) \text{ N-mm} \end{aligned}$$

Therefore,

$$\begin{aligned} \sigma_b &= \frac{M_b y}{I} \\ 80 &= \frac{(5000 \times 100) (1.5b)}{\left[ \frac{1}{12} (b) (3b)^3 \right]} \end{aligned}$$

$$\begin{aligned} \therefore b &= 16.09 \text{ mm} \\ d &= 3b = 3 (16.09) = 48.27 \text{ mm} \end{aligned} \quad (\text{iv})$$

### Example 3.17

A pressure vessel, used in chemical process industries, is shown in Fig. 3.43. It is designed to withstand an internal gauge pressure of 0.25 MPa. The cover is held tight against the vessel by means of a screw, which is turned down through the tapped hole in the beam, so that the end of the screw presses firmly against the cover. The links  $L_1$  and  $L_2$  are attached to the beam on one side and to the extension cast on the vessel on other side. The vessel and its cover are made of grey cast iron FG 200. The beam, screw, links and pins are made of steel FeE 250 ( $S_y = 250 \text{ N/mm}^2$ ). The factor of safety for all parts is 5. The beam has rectangular cross-section and the ratio of width to thickness is 2:1 ( $h = 2b$ ). Assume following data for screw (ISO Metric threads-coarse series):

Size	Pitch (mm)	Stress area ( $\text{mm}^2$ )
M 30	3.5	561
M 36	4	817
M 42	4.5	1120
M 48	5	1470

Determine:

- (i) Diameter of the screw;
- (ii) Dimensions of the cross-section of the beam;

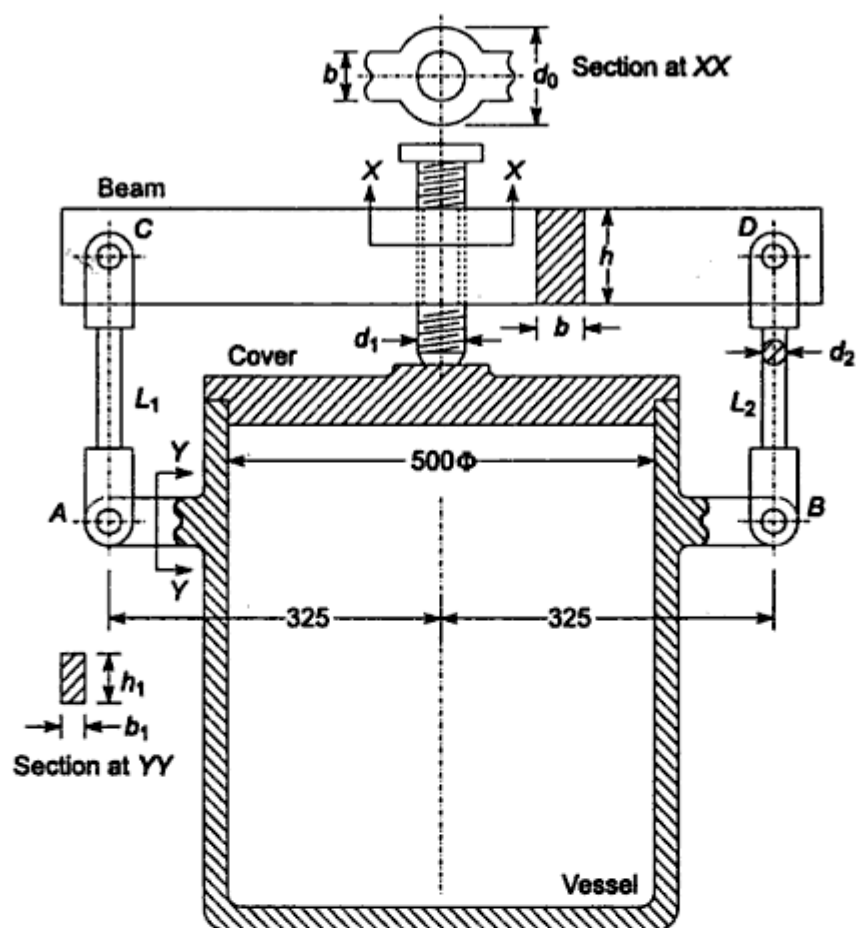

Fig. 3.43 Pressure Vessel

- (iii) Diameter of pins at A, B, C and D;
- (iv) Diameter  $d_2$  of link  $L_1$  and  $L_2$ ; and
- (v) Dimensions of the cross-section of the support for pin A and B.

**Solution**

Permissible stresses:

(a) Steel parts:

$$\sigma_t = \frac{S_{yt}}{(fs)} = \frac{250}{5} = 50 \text{ N/mm}^2$$

Assuming,

$$S_{yc} = S_{yt}$$

we get,

$$\sigma_c = \frac{S_{yc}}{(fs)} = \frac{250}{5} = 50 \text{ N/mm}^2$$

$$\tau = \frac{S_{sy}}{(fs)} = \frac{0.5 S_{yt}}{(fs)} = \frac{0.5 (250)}{5} = 25 \text{ N/mm}^2$$

(b) Cast iron parts:

$$\sigma_t = \frac{S_{ut}}{(fs)} = \frac{200}{5} = 40 \text{ N/mm}^2$$

The free body diagram of forces acting on various parts of the pressure vessel is shown in Fig. 3.44. This diagram is constructed starting with the forces acting on the cover and then proceeding to screw, beam, pin, link  $L_2$  and the extension of vessel to support the pin. The direction of forces acting on various parts are decided by using the following two principles:

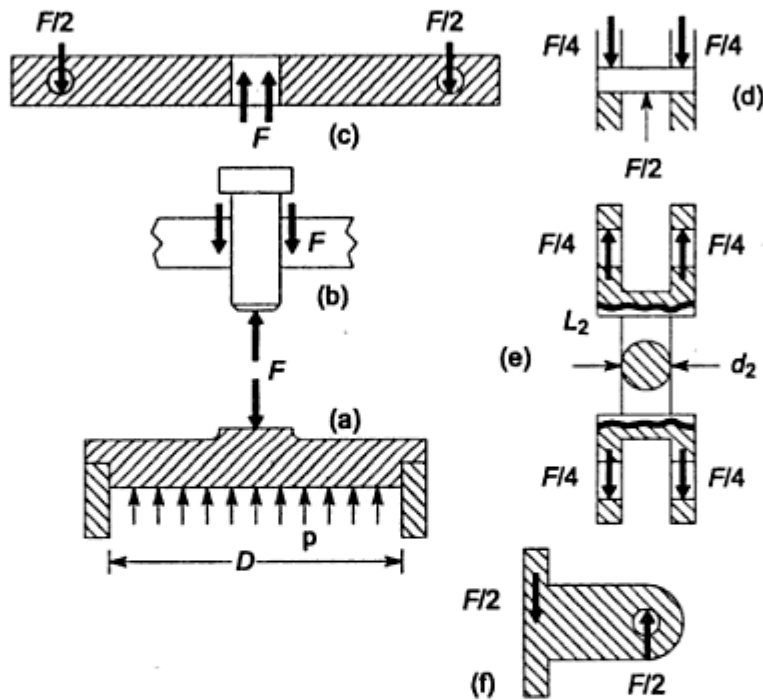

Fig. 3.44 Free Body Diagram of Forces

- (i) The sum of vertical forces acting on any part must be zero, and
- (ii) Action and reaction are equal and opposite.

(i) Diameter of screw:

The force acting on the cover, as shown in Fig. 3.44 (a) is given by,

$$\begin{aligned} F &= \frac{\pi}{4} D^2 p \\ &= \frac{\pi}{4} (500)^2 (0.25) \\ &= 49\,087.39 \text{ N} \end{aligned}$$

As shown in Fig. 3.44 (b), the portion of the screw between the beam and the cover is subjected to compressive stress. If 'a' is the stressed area of screw, then the compressive force is given by,

$$F = a \sigma_c$$

$$49087.39 = a \quad (50)$$

$$\therefore a = 981.75 \text{ mm}^2$$

From the given data, a screw of M42 size (stressed area = 1120 mm<sup>2</sup>) is suitable. The nominal diameter of the screw is 42 mm and the pitch 4.5 mm.

(ii) Cross-section of beam:

As shown in Fig. 3.45(a), the beam is simply supported with a single concentrated load  $F$  at the centre of the span length. Due to symmetry of loading, the reaction at each of the two pins,  $C$  and  $D$ , is equal to  $(F/2)$ . The maximum bending moment is  $M_b$  at the midpont of the beam. It is given by,

$$M_b = 325 \times \left(\frac{F}{2}\right) = 325 \times \left(\frac{49\,087.39}{2}\right)$$

or,

$$M_b = 7\,976\,700.88 \text{ N-mm}$$

Since,

$$h = 2b$$

$$I = \frac{bh^3}{12} = \frac{b(2b)^3}{12} = \left(\frac{2b^4}{3}\right) \text{ mm}^4$$

$$y = \frac{h}{2} = b \text{ mm}$$

From Eq. (3.12),

$$\sigma_b = \frac{M_b y}{I}$$

Substituting,

$$50 = \frac{(7\,976\,700.88)(b)}{\left[\frac{2}{3}(b^4)\right]}$$

$$\therefore b = 62.08 \text{ or } 65 \text{ mm}$$

$$h = 2b = 130 \text{ mm}$$

As shown in Fig. 3.45 (a), the axis of the tapped hole is parallel to 'h' dimension of the section. As shown in Fig. 3.45 (c), the solid rectangular section of the beam of thickness  $b$  can be split into two halves, each having a width  $(b/2)$  at the hole, so that the metallic area in a section through the hole is equal to the area of the solid section ( $h \times b$ ). In this case, the factor of safety will remain unchanged. The diameter of the hole ( $d_1$ ) is the nominal diameter of the screw. Therefore,

$$d_1 = 42 \text{ mm}$$

$$d_o = d_1 + \frac{b}{2} + \frac{b}{2} = 42 + \frac{65}{2} + \frac{65}{2} = 107 \text{ mm}$$